



FCC TEST REPORT (PART 24)

REPORT NO.: RF960621L09-1

MODEL NO.: VOGU100

RECEIVED: Jun. 21, 2007

TESTED: Jun. 21 ~ Jun. 27, 2007

ISSUED: Jul. 03, 2007

APPLICANT: High Tech Computer Corp.

ADDRESS: 23, Hsin-Hua Rd., Taoyuan, 330, Taiwan, R.O.C.

ISSUED BY: Advance Data Technology Corporation

LAB ADDRESS: No. 47, 14th Ling, Chia Pau Tsuen, Lin Kou Hsiang
244, Taipei Hsien, Taiwan, R.O.C.

TEST LOCATION: No. 19, Hwa Ya 2nd Rd., Wen Hwa Tsuen, Kwei
Shan Hsiang, Taoyuan Hsien 333, Taiwan, R.O.C.

This test report consists of 56 pages in total. It may be duplicated completely for legal use with the approval of the applicant. It should not be reproduced except in full, without the written approval of our laboratory. The client should not use it to claim product endorsement by TAF, A2LA or any government agencies. The test results in the report only apply to the tested sample.





TABLE OF CONTENTS

| | | |
|-------|---|----|
| 1 | CERTIFICATION | 4 |
| 2 | SUMMARY OF TEST RESULTS | 5 |
| 2.1 | MEASUREMENT UNCERTAINTY | 6 |
| 3 | GENERAL INFORMATION..... | 7 |
| 3.1 | GENERAL DESCRIPTION OF EUT..... | 7 |
| 3.2 | DESCRIPTION OF TEST MODES..... | 9 |
| 3.2.1 | CONFIGURATION OF SYSTEM UNDER TEST..... | 9 |
| 3.2.2 | TEST MODE APPLICABILITY AND TESTED CHANNEL DETAIL..... | 10 |
| 3.3 | GENERAL DESCRIPTION OF APPLIED STANDARDS..... | 13 |
| 3.4 | DESCRIPTION OF SUPPORT UNITS..... | 13 |
| 4 | TEST TYPES AND RESULTS..... | 14 |
| 4.1 | OUTPUT POWER MEASUREMENT..... | 14 |
| 4.1.1 | LIMITS OF OUTPUT POWER MEASUREMENT..... | 14 |
| 4.1.2 | TEST INSTRUMENTS..... | 15 |
| 4.1.3 | TEST PROCEDURES..... | 16 |
| 4.1.4 | TEST SETUP..... | 17 |
| 4.1.5 | EUT OPERATING CONDITIONS..... | 18 |
| 4.1.6 | TEST RESULTS..... | 19 |
| 4.2 | FREQUENCY STABILITY MEASUREMENT..... | 21 |
| 4.2.1 | LIMITS OF FREQUENCY STABILITY MEASUREMENT..... | 21 |
| 4.2.2 | TEST INSTRUMENTS..... | 21 |
| 4.2.3 | TEST PROCEDURE..... | 22 |
| 4.2.4 | TEST SETUP..... | 22 |
| 4.2.5 | TEST RESULTS..... | 23 |
| 4.3 | OCCUPIED BANDWIDTH MEASUREMENT..... | 24 |
| 4.3.1 | LIMITS OF OCCUPIED BANDWIDTH MEASUREMENT..... | 24 |
| 4.3.2 | TEST INSTRUMENTS..... | 24 |
| 4.3.3 | TEST SETUP..... | 24 |
| 4.3.4 | TEST PROCEDURES..... | 25 |
| 4.3.5 | TEST RESULTS..... | 26 |
| 4.4 | BAND EDGE MEASUREMENT..... | 32 |
| 4.4.1 | LIMITS OF BAND EDGE MEASUREMENT..... | 32 |
| 4.4.2 | TEST INSTRUMENTS..... | 32 |
| 4.4.3 | TEST SETUP..... | 32 |
| 4.4.4 | TEST PROCEDURES..... | 33 |
| 4.4.5 | EUT OPERATING CONDITION..... | 33 |
| 4.4.6 | TEST RESULTS..... | 34 |
| 4.5 | CONDUCTED SPURIOUS EMISSIONS..... | 35 |
| 4.5.1 | LIMITS OF CONDUCTED SPURIOUS EMISSIONS MEASUREMENT..... | 35 |
| 4.5.2 | TEST INSTRUMENTS..... | 35 |
| 4.5.3 | TEST PROCEDURE..... | 36 |
| 4.5.4 | TEST SETUP..... | 36 |
| 4.5.5 | EUT OPERATING CONDITIONS..... | 36 |



| | | |
|-------|--|----|
| 4.5.6 | TEST RESULTS | 37 |
| 4.6 | RADIATED EMISSION MEASUREMENT (BELOW 1GHz)..... | 43 |
| 4.6.1 | LIMITS OF RADIATED EMISSION MEASUREMENT | 43 |
| 4.6.2 | TEST INSTRUMENTS | 44 |
| 4.6.3 | TEST PROCEDURES | 45 |
| 4.6.4 | DEVIATION FROM TEST STANDARD | 45 |
| 4.6.5 | TEST SETUP | 46 |
| 4.6.6 | EUT OPERATING CONDITIONS | 46 |
| 4.6.7 | TEST RESULTS | 47 |
| 4.7 | EFFECTIVE RADIATED POWER MEASUREMENT (ABOVE 1GHz) | 48 |
| 4.7.1 | LIMITS OF RADIATED EMISSION MEASUREMENT | 48 |
| 4.7.2 | TEST INSTRUMENTS | 49 |
| 4.7.3 | TEST PROCEDURES | 50 |
| 4.7.4 | DEVIATION FROM TEST STANDARD | 50 |
| 4.7.5 | TEST SETUP | 51 |
| 4.7.6 | EUT OPERATING CONDITIONS | 51 |
| 4.7.7 | TEST RESULTS | 52 |
| 5 | INFORMATION ON THE TESTING LABORATORIES | 55 |
| 6 | APPENDIX A – MODIFICATIONS RECORDERS FOR ENGINEERING CHANGES TO THE EUT BY THE LAB..... | 56 |



1 CERTIFICATION

PRODUCT : Pocket PC phone

MODEL : VOGU100

APPLICANT : High Tech Computer Corp.

TESTED : Jun. 21 ~ Jun. 27, 2007

TEST SAMPLE : ENGINEERING SAMPLE

TEST STANDARDS : **FCC Part 24, Subpart E**
ANSI C63.4-2003

The above equipment (model: VOGU100) has been tested by **Advance Data Technology Corporation**, and found compliance with the requirement of the above standards. The test record, data evaluation & Equipment Under Test (EUT) configurations represented herein are true and accurate accounts of the measurements of the sample's EMC characteristics under the conditions specified in this report.

PREPARED BY : Rennie Wang , **DATE:** Jul. 03, 2007
Rennie Wang / Senior Specialist

TECHNICAL ACCEPTANCE : Long Chen , **DATE:** Jul. 03, 2007
Responsible for RF Long Chen / Senior Engineer

APPROVED BY : Gary Chang , **DATE:** Jul. 03, 2007
Gary Chang / Supervisor

2 SUMMARY OF TEST RESULTS

The EUT has been tested according to the following specifications:

| APPLIED STANDARD: FCC Part 24 & Part 2 / IC RSS-133 | | | |
|---|--|--------|---|
| STANDARD SECTION | TEST TYPE AND LIMIT | RESULT | REMARK |
| 2.1046 24.232 | Maximum Peak Output Power Limit: max. 2 watts e.i.r.p peak power | PASS | Meet the requirement of limit. Minimum passing margin is 24.85dBm at 1851.25MHz. |
| 2.1055 24.235 | Frequency Stability AFC Freq. Error vs. Voltage AFC Freq. Error vs. Temperature Limit: max. ± 2.5 ppm | PASS | Meet the requirement of limit. |
| 2.1049 24.238(b) | Occupied Bandwidth | PASS | Meet the requirement of limit. |
| 24.238(b) | Band Edge Measurements | PASS | Meet the requirement of limit. |
| 2.1051 24.238 | Conducted Spurious Emissions | PASS | Meet the requirement of limit. |
| 2.1053 24.238 | Radiated Spurious Emissions | PASS | Meet the requirement of limit. Minimum passing margin is -49.97dB at 825.11MHz. |

2.1 MEASUREMENT UNCERTAINTY

Where relevant, the following measurement uncertainty levels have been estimated for tests performed on the EUT as specified in CISPR 16-4:

| MEASUREMENT | FREQUENCY | UNCERTAINTY |
|---------------------|------------------|-------------|
| Conducted emissions | 9kHz ~ 30MHz | 2.44dB |
| Radiated emissions | 30MHz ~ 200MHz | 3.34dB |
| | 200MHz ~ 1000MHz | 3.35dB |
| | 1GHz ~ 18GHz | 2.26dB |
| | 18GHz ~ 40GHz | 1.94dB |

This uncertainty represents an expanded uncertainty expressed at approximately the 95% confidence level using a coverage factor of $k = 2$.

3 GENERAL INFORMATION

3.1 GENERAL DESCRIPTION OF EUT

| | |
|---|---|
| PRODUCT | Pocket PC phone |
| MODEL NO. | VOGU100 |
| FCC ID | NM8VOGU100 |
| POWER SUPPLY | 3.7Vdc from rechargeable lithium battery 5.0Vdc from power adapter 5.0Vdc from host equipment |
| MODULATION TYPE | OQPSK, HPSK |
| FREQUENCY RANGE | 1850MHz ~ 1910MHz |
| NUMBER OF CHANNEL | 1151 |
| MAX. CONDUCTED PEAK OUTPUT POWER | 23.70dBm (0.234Watts) |
| MAX. EIRP POWER | 24.85dBm (0.305Watts) |
| ANTENNA TYPE | Monopole antenna with 0dBi gain |
| DATA CABLE | 1.6m USB shielded cable without core |
| I/O PORTS | Refer to user's manual |
| ASSOCIATED DEVICES | Refer to NOTE below |
| EUT EXTREME VOL. RANGE | 3.6Vdc to 4.2Vdc |

NOTE:

1. The applicant defined the normal working voltage of the battery is from 3.6Vdc to 4.2Vdc.
2. The EUT is a CDMA2000 (850/1900) + 1xEVDO/ 1xRTT/ IS-95A/B Pocket PC phone with bluetooth V2.0 w EDR + AGPS functions. This report is only covered the function of CDMA1900. The bluetooth function is covered in another test report, which standard used is FCC Part 15. And the CDMA850 mobile phone function is covered in another test report, which standard used is FCC Part 22.
3. The EUT has following accessories.

| ACCESSORY | BRAND | MODEL | SUPPORTER | REMARKS |
|---------------|-------|---------|-----------|--|
| Belt Clip | HTC | PO S292 | NEWTECH | |
| Carrying Case | HTC | PO S290 | NEWTECH | |
| Earphone | HTC | HS S190 | Merry | |
| Splitter (1) | HTC | YC A130 | MEC | 10.5cm (earphone with audio interface) |
| Splitter (2) | HTC | YC A100 | Acon | 9.7cm (earphone with USB interface) |

4. The communicated functions of EUT listed as below:

| | | 850MHz | 1900MHz | With bluetooth V2.0 w EDR + AGPS functions |
|----|----------|--------|---------|--|
| 3G | CDMA | V | V | |
| | 1xEVDO | V | V | |
| | 1xRTT | V | V | |
| | IS-95A/B | V | V | |

5. The EUT has lithium batteries listed as below:

| BATTERY A: | |
|------------|-----------------|
| BRAND: | TWS |
| MODEL: | ELF0160 |
| RATING: | 3.7Vdc, 1100mAh |

| BATTERY B: | |
|------------|-----------------|
| BRAND: | SAMSUNG |
| MODEL: | ELF0160 |
| RATING: | 3.7Vdc, 1100mAh |

NOTE: After pre-tested both batteries, found battery A is worse, therefore all the test results came out from this.

6. The EUT was operated with following power adapters:

| ADAPTER 1: | |
|-------------|---|
| BRAND: | DELTA ELECTRONIC, INC. |
| MODEL: | ADP-5FH B |
| INPUT: | 100-240Vac, 0.2A, 50~60Hz |
| OUTPUT: | 5Vdc, 1A |
| POWER LINE: | DC 1.8m non-shielded cable without core |

| ADAPTER 2: | |
|-------------|---|
| BRAND: | htc |
| MODEL: | PSAA05A-050 |
| INPUT: | 100-240Vac, 200mA, 50-60Hz |
| OUTPUT: | 5.0Vdc, 1A |
| POWER LINE: | DC 1.8m non-shielded cable without core |

7. Refer to following table for ESN no.:

| ESN NO. |
|----------|
| 36AD00** |

8. The above EUT information was declared by manufacturer and for more detailed features description, please refer to the manufacturer's specifications or User's Manual.

3.2 DESCRIPTION OF TEST MODES

1151 channels are provided to this EUT in the CDMA1900 band. Therefore, the low, middle and high channels are chosen for testing.

| | CHANNEL | FREQUENCY | TX MODE |
|--------|---------|-------------|---------|
| LOW | 25 | 1851.25 MHz | SO55 |
| MIDDLE | 600 | 1880.00 MHz | SO55 |
| HIGH | 1175 | 1908.75 MHz | SO55 |

NOTE:

1. Below 1 GHz, the channel 25, 600 and 1175 were pre-tested in chamber. The channel 25 was the worst case and chosen for final test.
2. Above 1 GHz, the channel 25, 600 and 1175 were tested individually.
3. The channel space is 0.05MHz.
4. Since the EUT is considered a handheld unit, it was pre-tested on the positioned of each 3 axis. The worst case was found when positioned on Z-plane. Therefore only the test data of this Z-plane was used for radiated emission measurement test.
5. In this report, CDMA2000 (SO55) was the worst case for all test items, therefore, only the data was recorded in the following section.

3.2.1 CONFIGURATION OF SYSTEM UNDER TEST

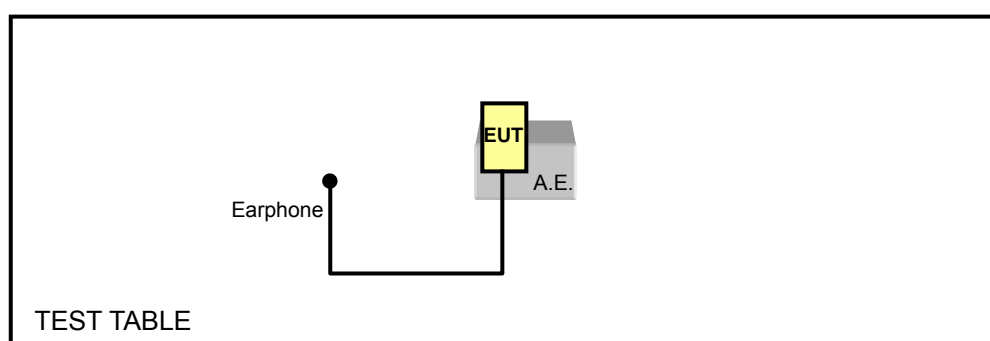

3.2.2 TEST MODE APPLICABILITY AND TESTED CHANNEL DETAIL

| EUT CONFIGURE MODE | APPLICABLE TO | | | | | | | DESCRIPTION |
|--------------------|---------------|----|----|----|----|-------|-------|-------------|
| | OP | FS | OB | BE | CE | RE<1G | RE≥1G | |
| - | V | V | V | V | V | V | V | - |

Where **OP**: Output power **FS**: Frequency stability
OB: Occupied bandwidth **BE**: Band edge
CE: Conducted spurious emissions **RE<1G**: Radiated emission below 1GHz
RE≥1G: Radiated emission above 1GHz

OUTPUT POWER MEASUREMENT:

- Pre-Scan has been conducted to determine the worst-case mode from all possible combinations between available modulations, data rates, xyz axis and antenna ports (if EUT with antenna diversity architecture).
- Following channel(s) was (were) selected for the final test as listed below.

| EUT CONFIGURE MODE | AVAILABLE CHANNEL | TESTED CHANNEL | MODULATION TECHNOLOGY | AXIS |
|--------------------|-------------------|----------------|-----------------------|------|
| - | 25 to 1175 | 25, 600, 1175 | CDMA | Z |

FREQUENCY STABILITY MEASUREMENT:

- Pre-Scan has been conducted to determine the worst-case mode from all possible combinations between available modulations, data rates, and antenna ports (if EUT with antenna diversity architecture).
- Following channel(s) was (were) selected for the final test as listed below.

| EUT CONFIGURE MODE | AVAILABLE CHANNEL | TESTED CHANNEL | MODULATION TECHNOLOGY |
|--------------------|-------------------|----------------|-----------------------|
| - | 25 to 1175 | 25 | CDMA |

OCCUPIED BANDWIDTH MEASUREMENT:

- Pre-Scan has been conducted to determine the worst-case mode from all possible combinations between available modulations, data rates, and antenna ports (if EUT with antenna diversity architecture).
- Following channel(s) was (were) selected for the final test as listed below.

| EUT CONFIGURE MODE | AVAILABLE CHANNEL | TESTED CHANNEL | MODULATION TECHNOLOGY |
|--------------------|-------------------|----------------|-----------------------|
| - | 25 to 1175 | 25, 600, 1175 | CDMA |

BAND EDGE MEASUREMENT:

- Pre-Scan has been conducted to determine the worst-case mode from all possible combinations between available modulations, data rates, and antenna ports (if EUT with antenna diversity architecture).
- Following channel(s) was (were) selected for the final test as listed below.

| EUT CONFIGURE MODE | AVAILABLE CHANNEL | TESTED CHANNEL | MODULATION TECHNOLOGY |
|--------------------|-------------------|----------------|-----------------------|
| - | 25 to 1175 | 25, 1175 | CDMA |

CONDUCTED SPURIOUS EMISSIONS MEASUREMENT:

- Pre-Scan has been conducted to determine the worst-case mode from all possible combinations between available modulations, data rates, and antenna ports (if EUT with antenna diversity architecture).
- Following channel(s) was (were) selected for the final test as listed below.

| EUT CONFIGURE MODE | AVAILABLE CHANNEL | TESTED CHANNEL | MODULATION TECHNOLOGY |
|--------------------|-------------------|----------------|-----------------------|
| - | 25 to 1175 | 25, 600, 1175 | CDMA |

RADIATED EMISSION MEASUREMENT (BELOW 1 GHz):

- Pre-Scan has been conducted to determine the worst-case mode from all possible combinations between available modulations, data rates, xyz axis and antenna ports (if EUT with antenna diversity architecture).
- Following channel(s) was (were) selected for the final test as listed below.

| EUT CONFIGURE MODE | AVAILABLE CHANNEL | TESTED CHANNEL | MODULATION TECHNOLOGY | AXIS |
|--------------------|-------------------|----------------|-----------------------|------|
| - | 25 to 1175 | 25 | CDMA | Z |

RADIATED EMISSION MEASUREMENT (ABOVE 1 GHz):

- Pre-Scan has been conducted to determine the worst-case mode from all possible combinations between available modulations, data rates, xyz axis and antenna ports (if EUT with antenna diversity architecture).
- Following channel(s) was (were) selected for the final test as listed below.

| EUT CONFIGURE MODE | AVAILABLE CHANNEL | TESTED CHANNEL | MODULATION TECHNOLOGY | AXIS |
|--------------------|-------------------|----------------|-----------------------|------|
| - | 25 to 1175 | 25, 600, 1175 | CDMA | Z |



3.3 GENERAL DESCRIPTION OF APPLIED STANDARDS

The EUT is a RF product. According to the specifications of the manufacturer, it must comply with the requirements of the following standards:

FCC 47 CFR Part 2

FCC 47 CFR Part 24

IC RSS-133

ANSI C63.4-2003

ANSI/TIA/EIA-603-A

NOTE: All test items have been performed and recorded as per the above standards.

3.4 DESCRIPTION OF SUPPORT UNITS

The EUT has been tested as an independent unit together with other necessary accessories or support units. The following support units or accessories were used to form a representative test configuration during the tests.

| NO. | PRODUCT | BRAND | MODEL NO. | SERIAL NO. | CAL. DATE |
|-----|--------------------------------------|-------|-----------|------------|---------------|
| 1 | Universal Radio Communication Tester | R&S | CMU200 | 104484 | Apr. 11, 2008 |

| NO. | SIGNAL CABLE DESCRIPTION OF THE ABOVE SUPPORT UNITS |
|-----|---|
| 1 | NA |

NOTE: All power cords of the above support units are non shielded (1.8m).



4 TEST TYPES AND RESULTS

4.1 OUTPUT POWER MEASUREMENT

4.1.1 LIMITS OF OUTPUT POWER MEASUREMENT

The radiated peak output power shall be according to the specific rule Part 24.232(b) that "Mobile / Portable station are limited to 2 watts e.i.r.p" and 24.232(c) specific that "Peak transmit power must be measure over any interval of continuous transmission using instrumentation calibration in terms of rms-equivalent voltage."



4.1.2 TEST INSTRUMENTS

| DESCRIPTION & MANUFACTURER | MODEL NO. | SERIAL NO. | CALIBRATED UNTIL |
|---|-------------------|-------------|------------------|
| Test Receiver ROHDE & SCHWARZ | ESCI | 100424 | Aug 04, 2007 |
| Spectrum Analyzer ROHDE & SCHWARZ | FSP40 | 100025 | Oct. 05, 2007 |
| BILOG Antenna SCHWARZBECK | VULB9168 | 9168-160 | May 31, 2008 |
| HORN Antenna SCHWARZBECK | 9120D | 9120D-209 | Jun. 28, 2008 |
| HORN Antenna SCHWARZBECK | BBHA 9170 | BBHA9170243 | Dec. 28, 2007 |
| Preamplifier Agilent | 8447D | 2944A10633 | Oct. 26, 2007 |
| Preamplifier Agilent | 8449B | 3008A01964 | Oct. 26, 2007 |
| RF signal cable HUBER+SUHNNER | SUCOFLEX 104 | 238137/4 | Dec. 11, 2007 |
| RF signal cable HUBER+SUHNNER | SUCOFLEX 104 | 233233/4 | Nov. 14, 2007 |
| Software ADT. | ADT_Radiated_V7.6 | NA | NA |
| Antenna Tower inn-co GmbH | MA 4000 | 013303 | NA |
| Antenna Tower Controller inn-co GmbH | CO2000 | 017303 | NA |
| Turn Table ADT. | TT100. | TT93021703 | NA |
| Turn Table Controller ADT. | SC100. | SC93021703 | NA |

- NOTE:**
1. The calibration interval of the above test instruments is 12 months and the calibrations are traceable to NML/ROC and NIST/USA.
 2. The test was performed in HwaYa Chamber 3.
 3. The horn antenna and HP preamplifier (model: 8449B) are used only for the measurement of emission frequency above 1GHz if tested.
 4. The VCCI Site Registration No. is R-237.
 5. The IC Site Registration No. is IC3789B-3.

4.1.3 TEST PROCEDURES

- a. The EUT was set up for the maximum peak power with CDMA link data modulation. The power was measured with R&S Spectrum Analyzer. All measurements were done at 3 channels: 25, 600 and 1175 (low, middle and high operational frequency range).
- b. The conducted peak output power used the power splitter via EUT RF power connector between simulation base station and spectrum analyzer. The path loss included the splitter loss, cable loss and 20dB pad loss. The spectrum set RB/VB 3MHz, then read peak power value and record to the test. (All transmitted path loss shall be considered in the test report data.)
- c. E.I.R.P peak power measurement. In the fully anechoic chamber, EUT placed on the 1.5m height of Turn Table, rotated the table around 360 degrees to search the maximum radiation power and receiver antenna shall be rotated vertical and horizontal polarization to find the maximum polar radiated power. The “Read Value” is the spectrum reading the maximum power value.
- d. The substitution horn antenna is substituted for EUT at the same position and signal generator export the CW signal to the calibration antenna. Rotated the Turn Table to find the maximum radiation power. “Raw” is the spectrum reading value, “SG” is signal generator export power, “TX Gain” is calibration antenna isotropic gain value, “TX cable” is the transmitted cable loss between the calibration antenna and signal generator. The “Factor” means that the transmission path loss is equal to “SG” - “TX cable” + “TX Gain” – “Raw”.
- e. Actually the real E.I.R.P peak power is equal to “Read Value” + “Factor”.

4.1.4 TEST SETUP

EIRP POWER MEASUREMENT:

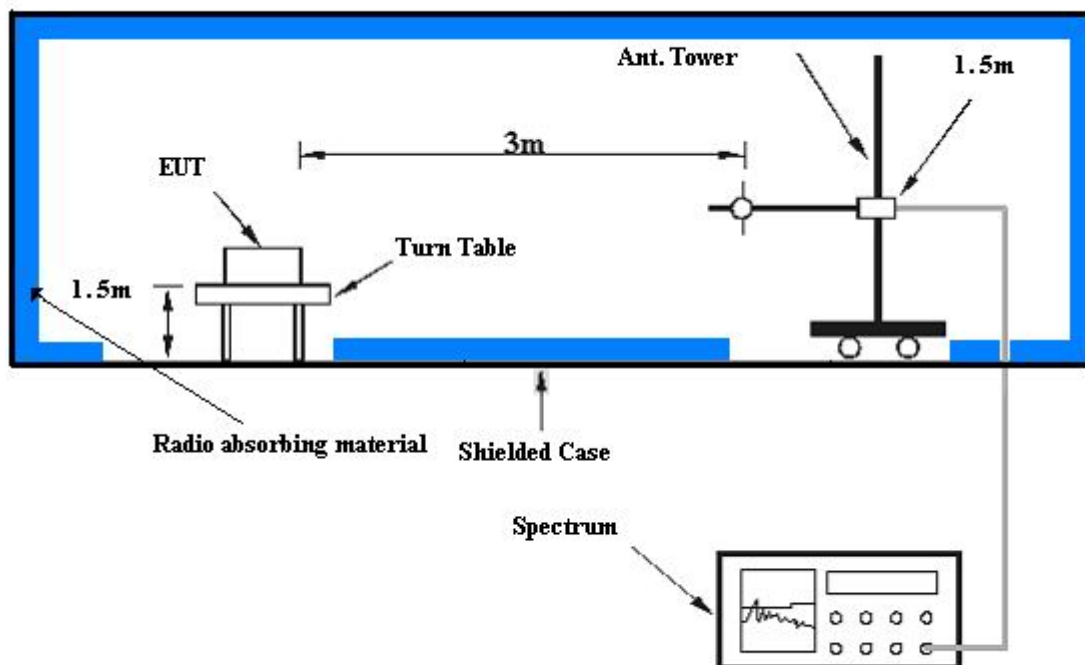

For the actual test configuration, please refer to the attached file (Test Setup Photo).

CONDUCTED POWER MEASUREMENT:

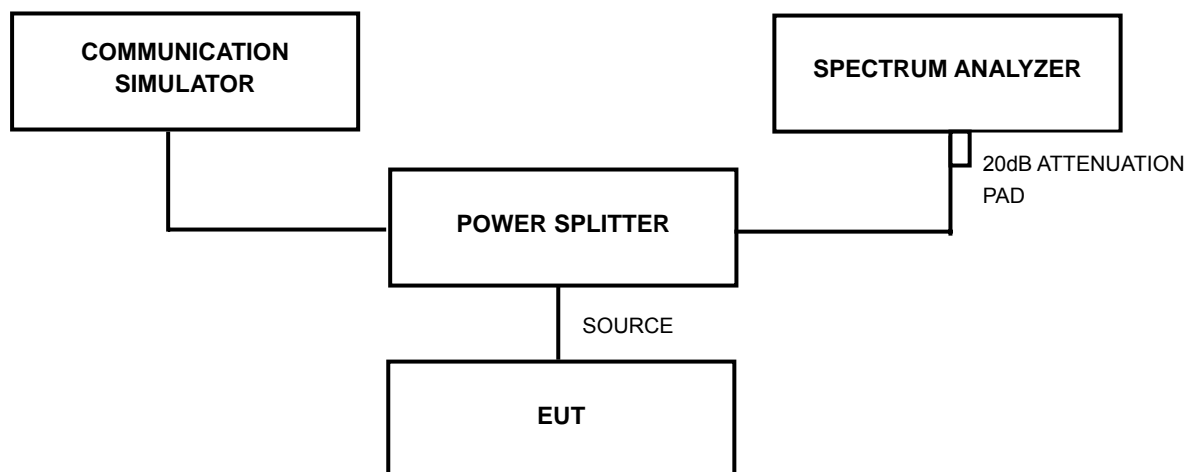

For the actual test configuration, please refer to the attached file (Test Setup Photo).



4.1.5 EUT OPERATING CONDITIONS

- a. The EUT makes a phone call to the communication simulator.
- b. The communication simulator station system controlled an EUT to export maximum output power under transmission mode and specific channel frequency.



4.1.6 TEST RESULTS

| | | | |
|-----------------------------|--------------|---------------------------------|-------------------------|
| MODE | TX connected | DETECTOR FUNCTION | Average |
| INPUT POWER (SYSTEM) | 120Vac, 60Hz | ENVIRONMENTAL CONDITIONS | 22deg. C, 60%RH, 983hPa |
| TESTED BY | Match Tsui | | |

| CONDUCTED POWER (1x EV-DO) | | | | | | | | |
|----------------------------|-------------|-----------------|-------|-------------------|-------------------|-------|-------|-------|
| CHANNEL | FREQ. (MHz) | RAW VALUE (dBm) | | CORR. FACTOR (dB) | PEAK OUTPUT POWER | | | |
| | | RTAP | FTAP | | RTAP | | FTAP | |
| | | | | | dBm | Watt | dBm | Watt |
| 25 | 1851.25 | 18.21 | 18.38 | 5.00 | 23.21 | 0.209 | 23.38 | 0.218 |
| 600 | 1880.00 | 18.20 | 18.42 | 5.00 | 23.20 | 0.209 | 23.42 | 0.220 |
| 1175 | 1908.75 | 18.22 | 18.36 | 5.00 | 23.22 | 0.210 | 23.36 | 0.217 |

| CDMA 2000 CONDUCTED POWER (SO2, SO55, TDSO SO32, SO3) | | | | | | | | | | | |
|---|-------------|--------------|-----------------|-------|-----------|-------|-------------------|-------------------------|--------------|-----------|-------|
| CHAN. | FREQ. (MHz) | CDMA 2000 RC | RAW VALUE (dBm) | | | | CORR. FACTOR (dB) | PEAK OUTPUT POWER (dBm) | | | |
| | | | SO2 | SO55 | TDSO SO32 | SO3 | | SO2 | SO55 | TDSO SO32 | SO3 |
| 25 | 1851.25 | RC1 | 18.35 | 18.41 | - | 18.35 | 5.00 | 23.35 | 23.41 | - | 23.35 |
| | | RC3 | 18.41 | 18.58 | 18.36 | 18.42 | 5.00 | 23.41 | 23.58 | 23.36 | 23.42 |
| 600 | 1880.00 | RC1 | 18.64 | 18.62 | - | 18.67 | 5.00 | 23.64 | 23.62 | - | 23.67 |
| | | RC3 | 18.66 | 18.70 | 18.64 | 18.68 | 5.00 | 23.66 | 23.70 | 23.64 | 23.68 |
| 1175 | 1908.75 | RC1 | 18.61 | 18.59 | - | 18.61 | 5.00 | 23.61 | 23.59 | - | 23.61 |
| | | RC3 | 18.62 | 18.69 | 18.63 | 18.66 | 5.00 | 23.62 | 23.69 | 23.63 | 23.66 |

- REMARKS:** 1. Peak Output Power (dBm) = Raw Value (dBm) + Correction Factor (dB).
 2. Correction Factor (dB) = Power Splitter Loss (dB) + Cable Loss (dB).
 3. The value in bold is the worst.



| | | | |
|-----------------------------|--------------|---------------------------------|-------------------------|
| MODE | TX connected | DETECTOR FUNCTION | Average |
| INPUT POWER (SYSTEM) | 120Vac, 60Hz | ENVIRONMENTAL CONDITIONS | 22deg. C, 60%RH, 983hPa |
| TESTED BY | Match Tsui | | |

| EIRP POWER (1x EV-DO) | | | | | | | | |
|-----------------------|-------------|-----------------|--------|-------------------|-------------------|-------|-------|-------|
| CHANNEL | FREQ. (MHz) | RAW VALUE (dBm) | | CORR. FACTOR (dB) | PEAK OUTPUT POWER | | | |
| | | | | | RTAP | | FTAP | |
| | | RTAP | FTAP | | dBm | Watt | dBm | Watt |
| 25 | 1851.25 | -15.68 | -15.52 | 40.03 | 24.35 | 0.272 | 24.51 | 0.282 |
| 60 | 1880.00 | -16.66 | -16.51 | 40.32 | 23.66 | 0.232 | 23.81 | 0.240 |
| 1175 | 1908.75 | -18.51 | -18.37 | 40.62 | 22.11 | 0.163 | 22.25 | 0.168 |

| EIRP POWER (S055) | | | | | |
|-------------------|-----------------|-----------------|------------------------|-------------------|--------------|
| CHANNEL NO. | FREQUENCY (MHz) | RAW VALUE (dBm) | CORRECTION FACTOR (dB) | PEAK OUTPUT POWER | |
| | | | | dBm | Watt |
| 25 | 1851.25 | -15.18 | 40.03 | 24.85 | 0.305 |
| 600 | 1880.00 | -16.16 | 40.32 | 24.16 | 0.261 |
| 1175 | 1908.75 | -17.85 | 40.62 | 22.77 | 0.189 |

- REMARKS:**
1. Peak Output Power (dBm) = Raw Value (dBm) + Correction Factor (dB).
 2. Correction Factor (dB) = Receiver Antenna Gain (dBi) + Cable Loss (dB) + Free Space Loss (dB).
 3. The value in bold is the worst.



4.2 FREQUENCY STABILITY MEASUREMENT

4.2.1 LIMITS OF FREQUENCY STABILITY MEASUREMENT

According to the FCC part 2.4235 shall be tested the frequency stability. The rule is defined that "The frequency stability shall be sufficient to ensure that the fundamental emission stays within the authorized frequency block." The frequency error rate is according to the JTC standard that the frequency error rate shall be accurate to within 2.5ppm of the received frequency from the base station. The test extreme voltage is according to the 2.1055(d)(1) Vary primary supply voltage from 85 to 115 percent of the nominal value for other than hand carried battery equipment and the extreme temperature rule is comply with the 2.1055(a)(1) $-30^{\circ}\text{C} \sim 50^{\circ}\text{C}$.

4.2.2 TEST INSTRUMENTS

| DESCRIPTION & MANUFACTURER | MODEL NO. | SERIAL NO. | CALIBRATED UNTIL |
|---|-------------|------------|------------------|
| * Hewlett Packard RF cable | 8120-6192 | 01428251 | NA |
| * Suhner RF cable | Sucoflex104 | 204850/4 | NA |
| * WIT Standard Temperature & Humidity Chamber | TH-4S-C | W981030 | Jul. 10, 2007 |

- NOTE:**
1. The calibration interval of the above test instruments is 12 months. And the calibrations are traceable to NML/ROC and NIST/USA.
 2. "*" = These equipments are used for the final measurement.
 3. The test was performed in ADT RF OVEN room.

4.2.3 TEST PROCEDURE

- a. Because of the measure the carrier frequency under the condition of the AFC lock, it shall be used the mobile station in the CDMA link mode. This is accomplished with the use of the communication simulator station. The oven room could control the temperatures and humidity. The link channel is the 9538.
- b. Power must be removed when changing from one temperature to another or one voltage to another voltage. Power warm up is at least 15 min and power applied should perform before recording frequency error.
- c. EUT is connected the external power supply to control the DC input power. The various Volts from the minimum 3.6 Volts to 4.2 Volts. Each step shall be record the frequency error rate.
- d. The temperature range step is 10 degrees in this test items. All temperature levels shall be hold the $\pm 0.5^{\circ}\text{C}$ during the measurement testing.
- e. The each temperature step shall be at least 0.5 hours, consider the EUT could be test under the stability condition.

NOTE: The frequency error was recorded frequency error from the communication simulator.

4.2.4 TEST SETUP

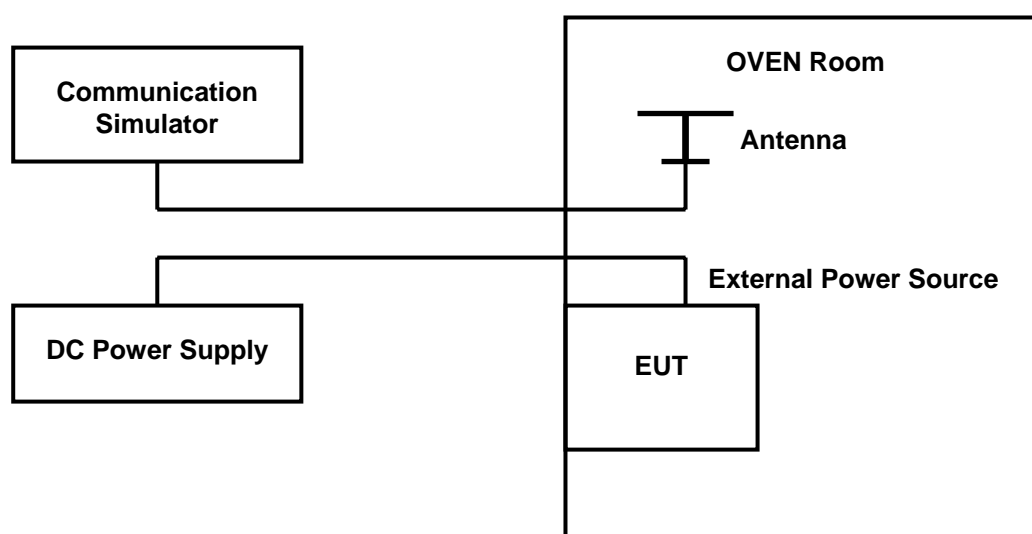



4.2.5 TEST RESULTS

| | | | |
|-----------------------------|--------------|---------------------------------|-------------------------|
| MODE | Channel 25 | ENVIRONMENTAL CONDITIONS | 22deg. C, 60%RH, 983hPa |
| INPUT POWER (SYSTEM) | 120Vac, 60Hz | TESTED BY | Match Tsui |

| AFC FREQUENCY ERROR vs. VOLTAGE | | | |
|---------------------------------|----------------------|-----------------------|-------------|
| VOLTAGE (Volts) | FREQUENCY ERROR (Hz) | FREQUENCY ERROR (ppm) | LIMIT (ppm) |
| 3.6 | 16 | 0.0119545726 | 2.5 |
| 4.2 | 14 | 0.0131500299 | 2.5 |

NOTE: The applicant defined the normal working voltage of the battery is from 3.6Vdc to 4.2Vdc.

| AFC FREQUENCY ERROR vs. TEMP. | | | |
|-------------------------------|----------------------|-----------------------|-------------|
| TEMP. (°C) | FREQUENCY ERROR (Hz) | FREQUENCY ERROR (ppm) | LIMIT (ppm) |
| 50 | 17 | 0.0191273162 | 2.5 |
| 40 | 15 | 0.0167364017 | 2.5 |
| 30 | 14 | 0.0155409444 | 2.5 |
| 20 | 12 | 0.0131500299 | 2.5 |
| 10 | 12 | 0.0095636581 | 2.5 |
| 0 | 15 | 0.0107591154 | 2.5 |
| -10 | 16 | 0.0119545726 | 2.5 |
| -20 | 17 | 0.0143454871 | 2.5 |
| -30 | 18 | 0.0155409444 | 2.5 |



4.3 OCCUPIED BANDWIDTH MEASUREMENT

4.3.1 LIMITS OF OCCUPIED BANDWIDTH MEASUREMENT

According to FCC 24.238(b) specified that emission bandwidth is defined as the width of the signal between two points, one below the carrier center frequency and one above the carrier center frequency, outside of which all emissions are attenuated at least 26dB below the transmitter power.

4.3.2 TEST INSTRUMENTS

| DESCRIPTION & MANUFACTURER | MODEL NO. | SERIAL NO. | CALIBRATED UNTIL |
|--|--------------|------------|------------------|
| * ROHDE & SCHWARZ Spectrum Analyzer | FSP40 | 100035 | Mar. 25, 2008 |
| * Mini-Circuits Power Splitter | ZAPD-4 | 400005 | NA |
| * Hewlett Packard RF cable | 8120-6192 | 01428251 | NA |
| * JFW 20dB attenuation | 50HF-020-SMA | NA | NA |
| * Suhner RF cable | Sucoflex104 | 204850/4 | NA |

NOTE: 1. The calibration interval of the above test instruments is 12 months. And the calibrations are traceable to NML/ROC and NIST/USA.

2. "*" = These equipments are used for the final measurement.

4.3.3 TEST SETUP

Same as Item 4.2.4 (Conducted Power Setup)

4.3.4 TEST PROCEDURES

- a. The EUT makes a phone call to the communication simulator. The power was measured with R&S Spectrum Analyzer. All measurements were done at 3 channels, 25, 600 and 1175 (low, middle and high operational frequency range.)
- b. The conducted occupied bandwidth used the power splitter via EUT RF power connector between simulation base station and spectrum analyzer. This splitter loss and cable loss are the worst loss 5dB in the transmitted path track.
- c. The communication simulator station system controlled a EUT to export maximum output power under transmission mode and specific channel frequency. FCC 24.238(b) required a measurement bandwidth is the fundamental emission below 26dB bandwidth.

4.3.5 TEST RESULTS

For S055:

| FREQUENCY (MHz) | MAX. OUTPUT POWER -26 dBc BANDWIDTH (MHz) |
|-----------------|---|
| 1851.25 | 1.404 |
| 1880.00 | 1.422 |
| 1908.75 | 1.440 |

CH 25 MAX. POWER

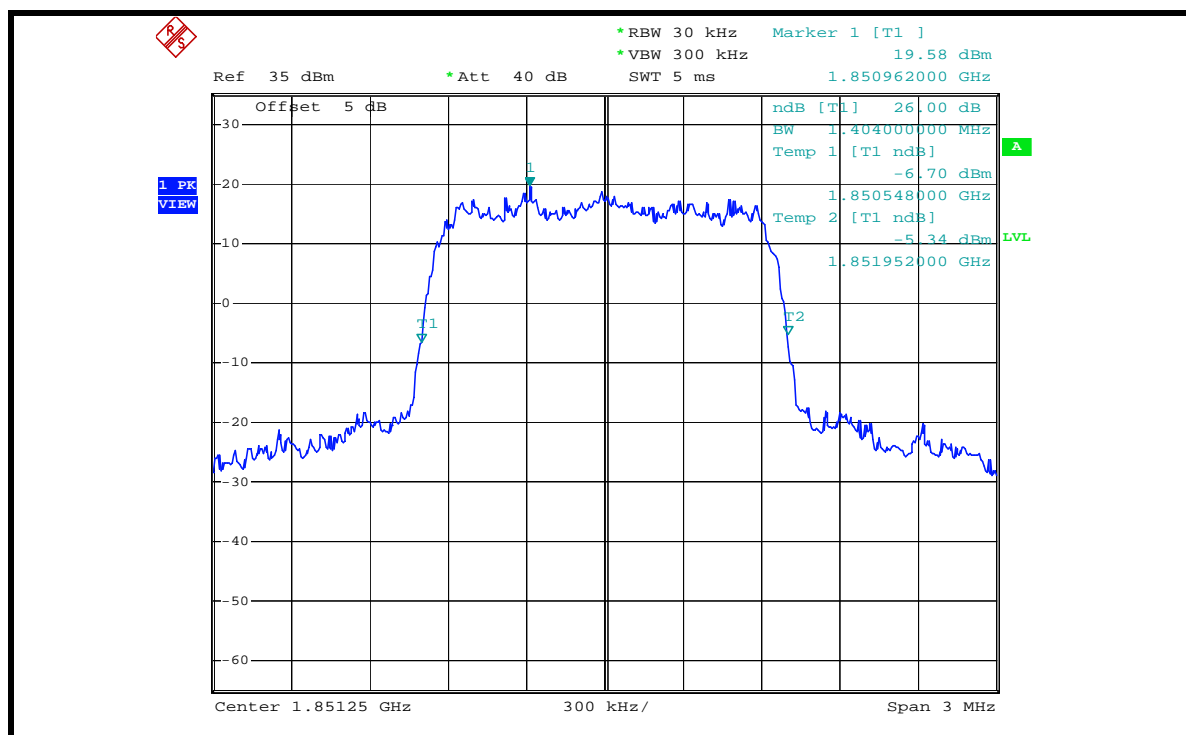

CH 600 MAX. POWER

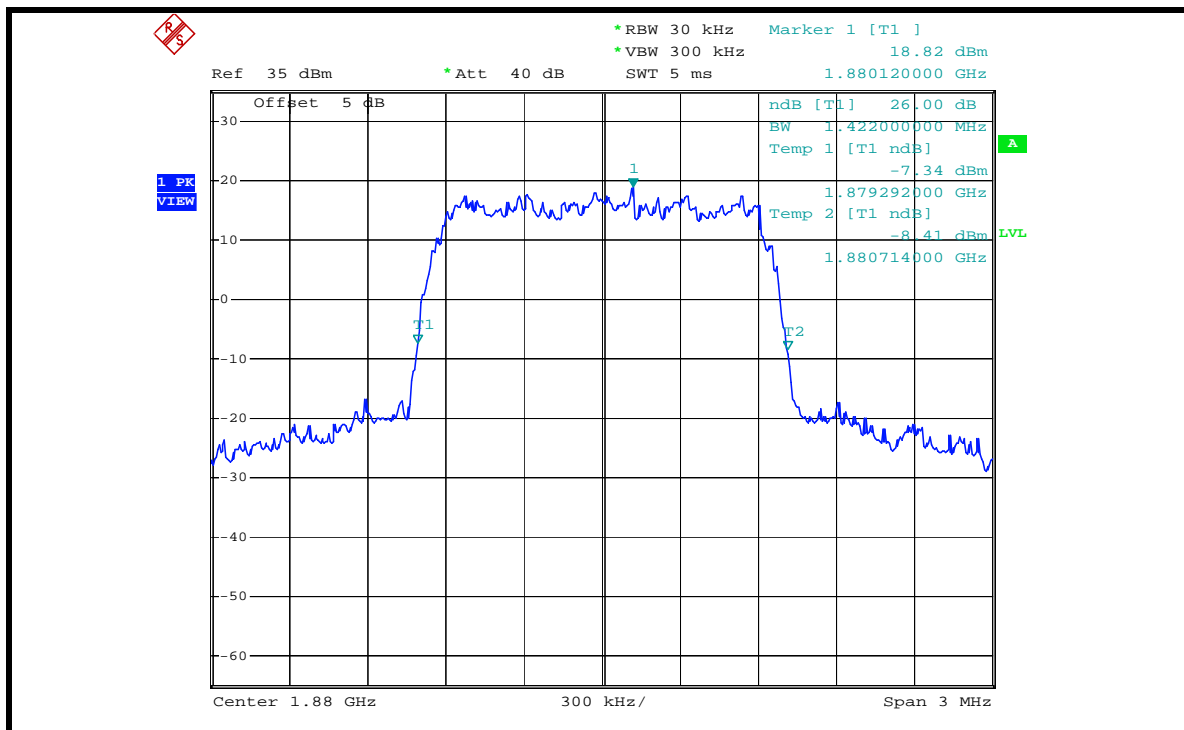

CH 1175 MAX. POWER

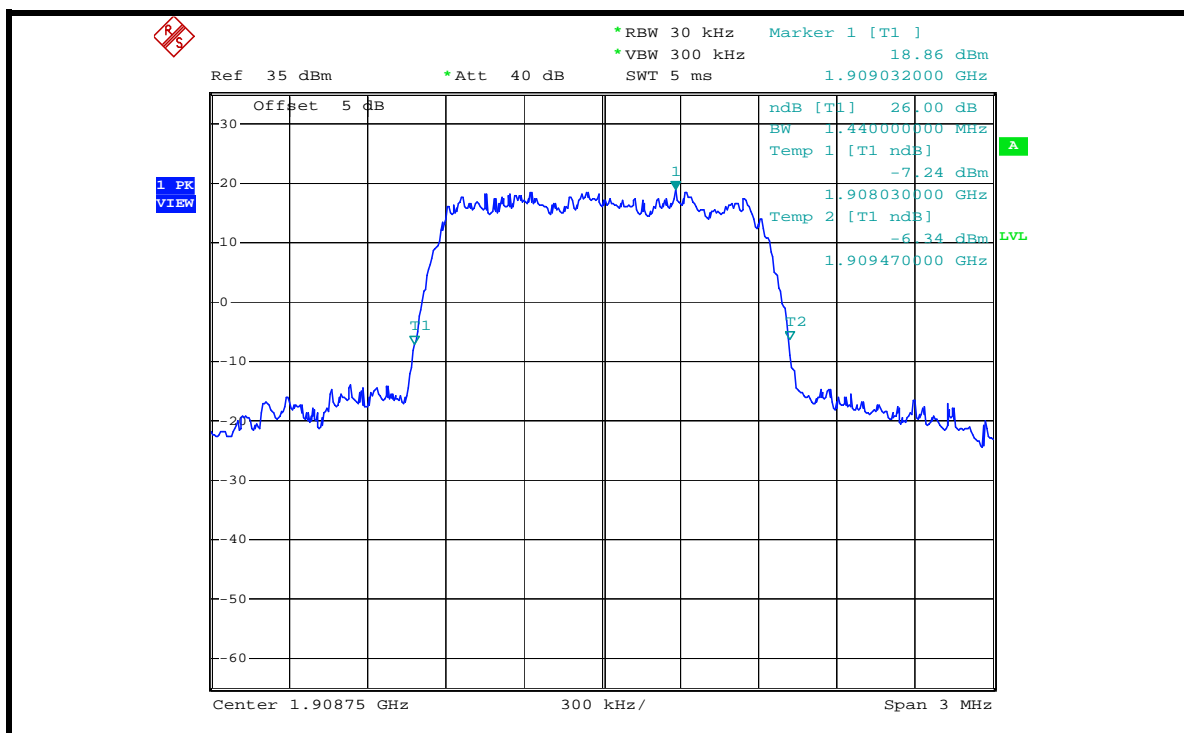

For EV-DO FTAP:

| FREQUENCY (MHz) | MAX. OUTPUT POWER -26 dBc BANDWIDTH (MHz) |
|-----------------|---|
| 1851.25 | 1.428 |
| 1880.00 | 1.422 |
| 1908.75 | 1.434 |

CH 25 MAX. POWER

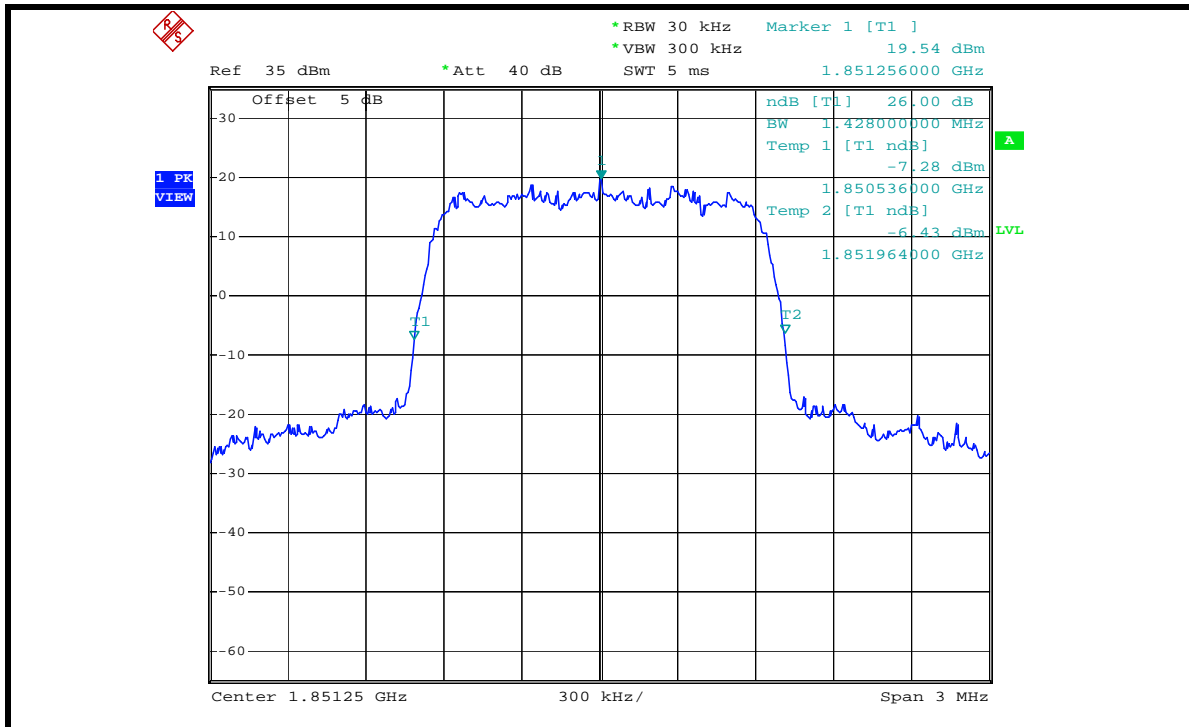

CH 600 MAX. POWER

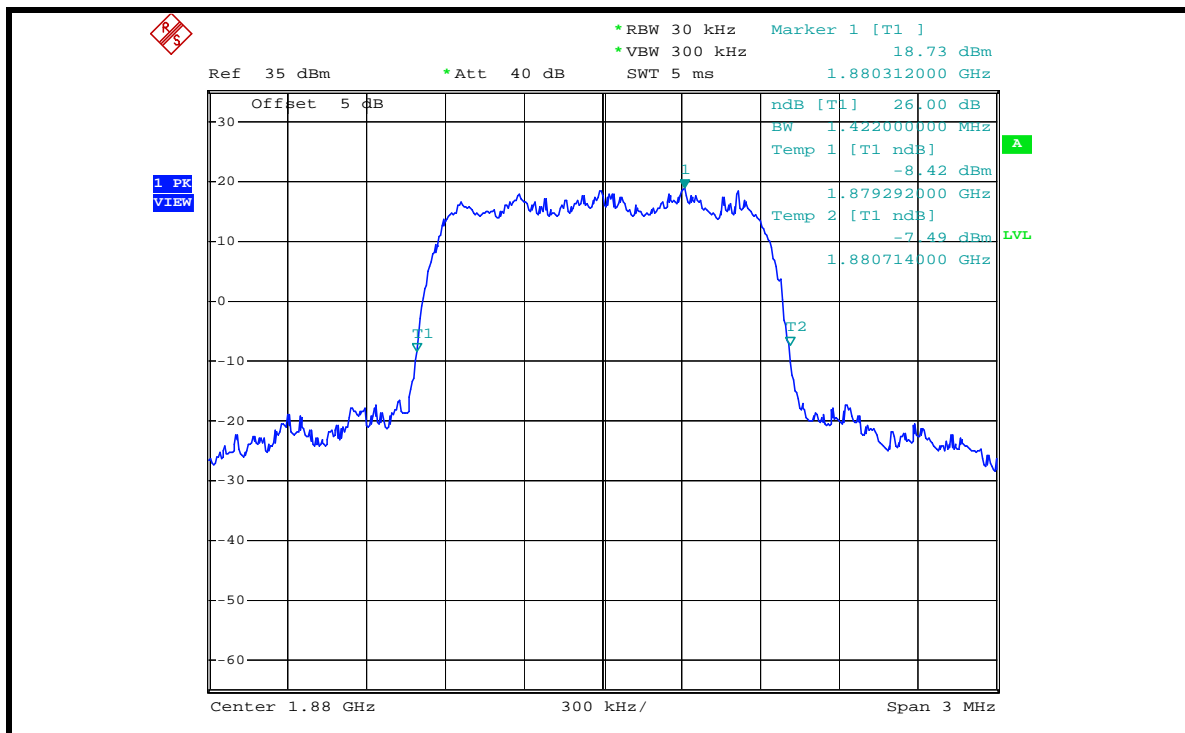

CH 1175 MAX. POWER

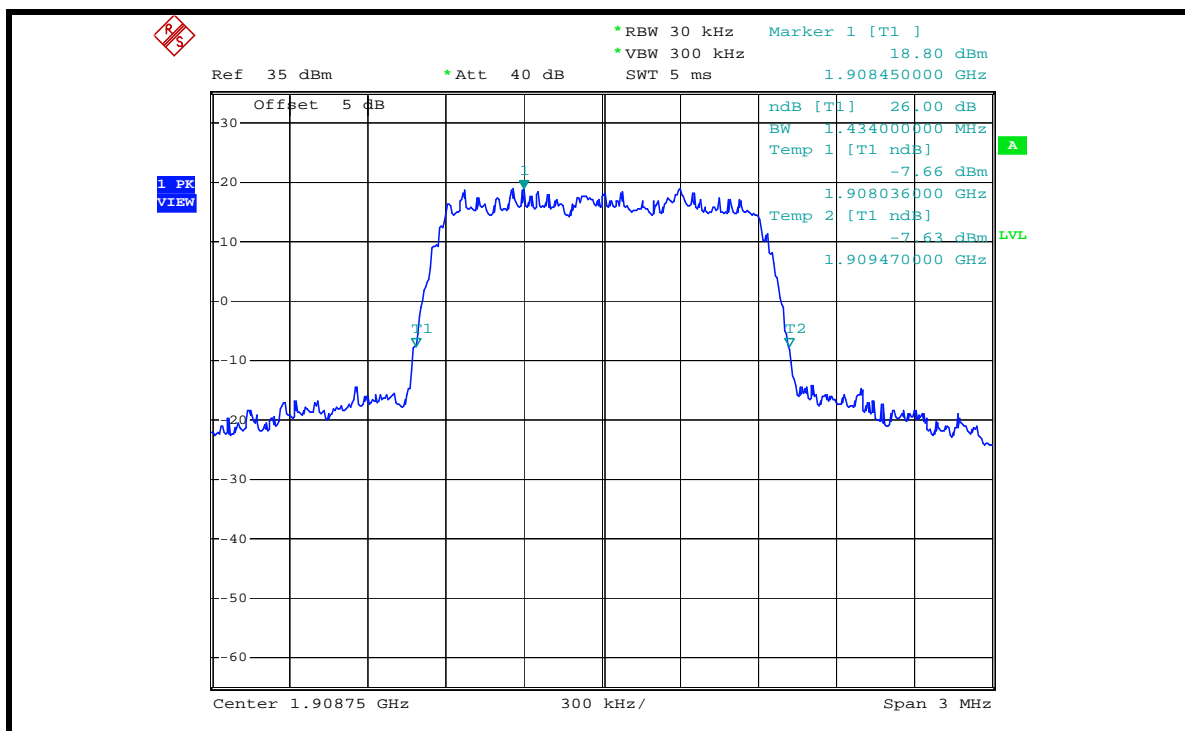

For EV-DO RTAP:

| FREQUENCY (MHz) | MAX. OUTPUT POWER -26 dBc BANDWIDTH (MHz) |
|-----------------|---|
| 1851.25 | 1.428 |
| 1880.00 | 1.428 |
| 1908.75 | 1.434 |

CH 25 MAX. POWER

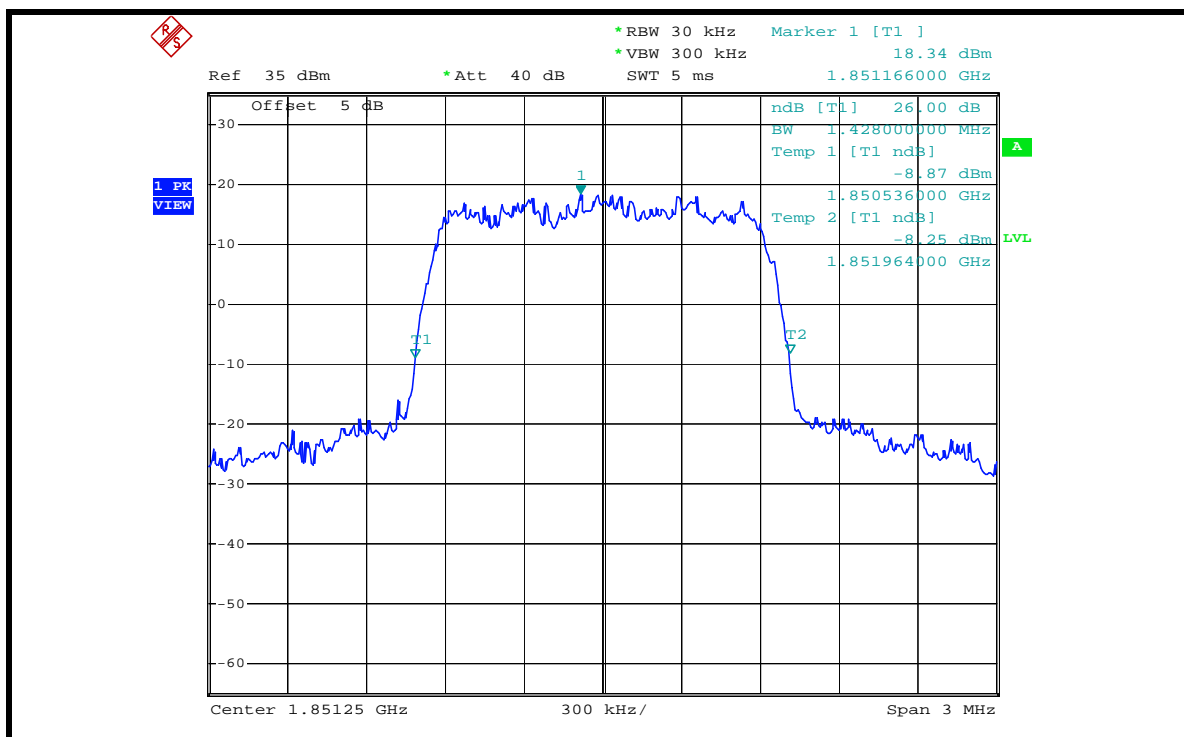

CH 600 MAX. POWER

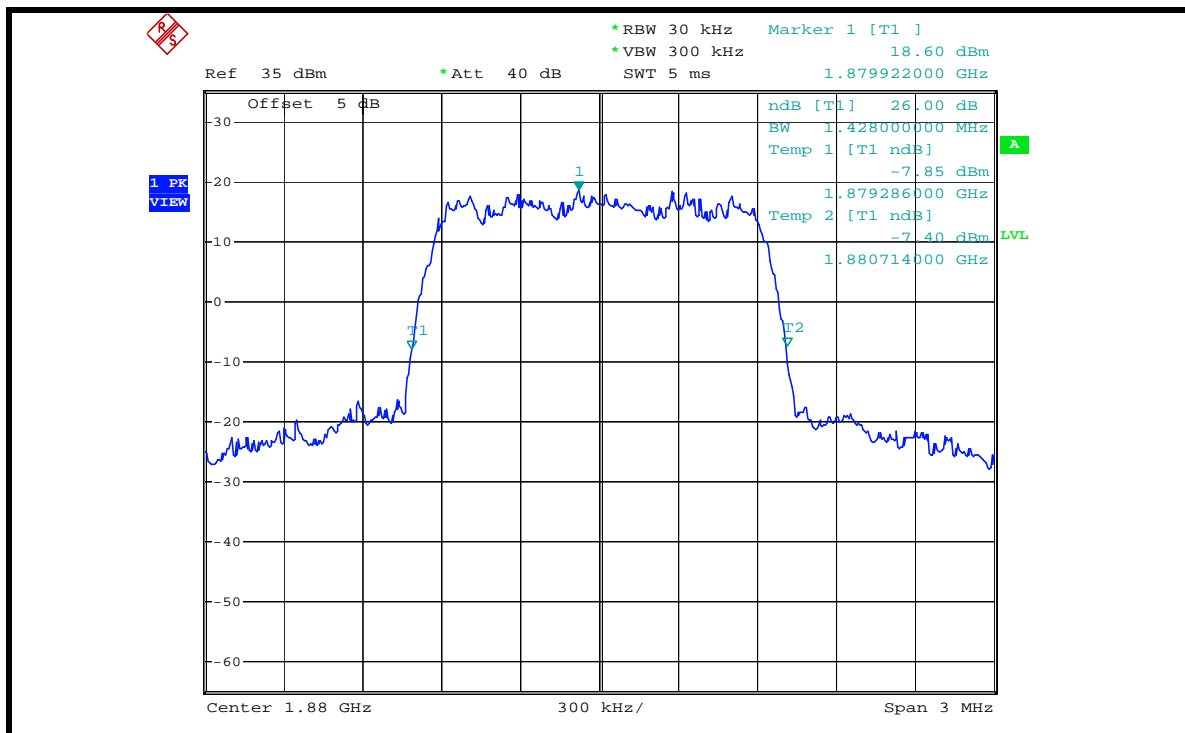

CH 1175 MAX. POWER

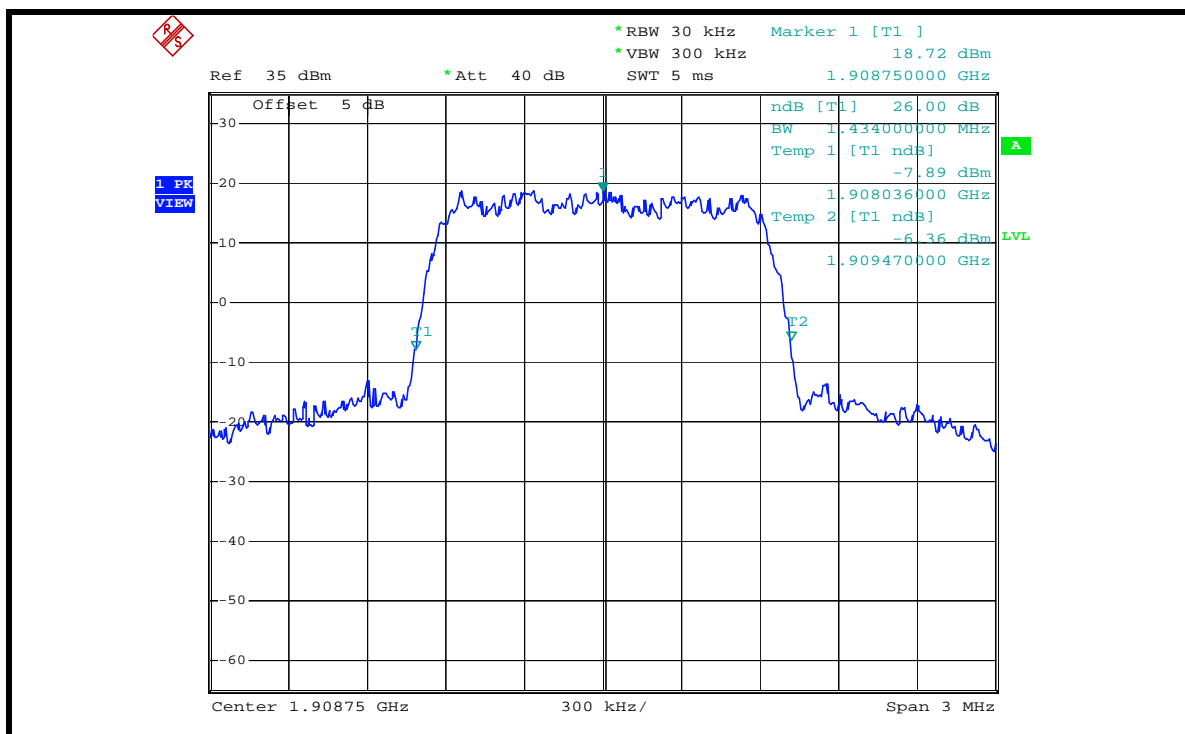



4.4 BAND EDGE MEASUREMENT

4.4.1 LIMITS OF BAND EDGE MEASUREMENT

The PCS frequency bands refer to the FCC 24.229 rule. According to FCC 24.238(a) specified that power of any emission outside of the authorized operating frequency ranges must be attenuated below the transmitting power (P) by a factor of at least $43 + 10 \log(P)$ dB. In the 1 MHz bands immediately outside and adjacent to the frequency block a resolution bandwidth of at least one percent of the emission bandwidth of the fundamental emission of the transmitter may be employed.

4.4.2 TEST INSTRUMENTS

| DESCRIPTION & MANUFACTURER | MODEL NO. | SERIAL NO. | CALIBRATED UNTIL |
|--|--------------|------------|------------------|
| * ROHDE & SCHWARZ Spectrum Analyzer | E4446A | MY44360128 | Dec. 03, 2007 |
| * Mini-Circuits Power Splitter | ZAPD-4 | 400005 | NA |
| * Hewlett Packard RF cable | 8120-6192 | 01428251 | NA |
| * JFW 20dB attenuation | 50HF-020-SMA | NA | NA |
| * Suhner RF cable | Sucoflex104 | 204850/4 | NA |

NOTE: 1. The calibration interval of the above test instruments is 12 months. And the calibrations are traceable to NML/ROC and NIST/USA.

2. "*" = These equipments are used for the final measurement.

4.4.3 TEST SETUP

Same as Item 4.2.4 (Conducted Power Setup)

4.4.4 TEST PROCEDURES

- a. The EUT was set up for the maximum peak power with CDMA link data modulation. The power was measured with R&S Spectrum Analyzer. All measurements were done at 2 channels, 25 and 1175 (low and high operational frequency range.)
- b. The band edge measurement used the power splitter via EUT RF power connector between simulation base station and spectrum analyzer. This splitter loss and cable loss are the worst loss 5dB in the transmitted path track.
- c. The center frequency of spectrum is the band edge frequency and span is 3 MHz. RB of the spectrum is 15kHz and VB of the spectrum is 15kHz.
- d. Record the max trace plot into the test report.

4.4.5 EUT OPERATING CONDITION

- a. The EUT makes a phone call to the communication simulator.
- b. The communication simulator station system controlled an EUT to export maximum output power under transmission mode and specific channel frequency.

4.4.6 TEST RESULTS

LOWER BAND EDGE

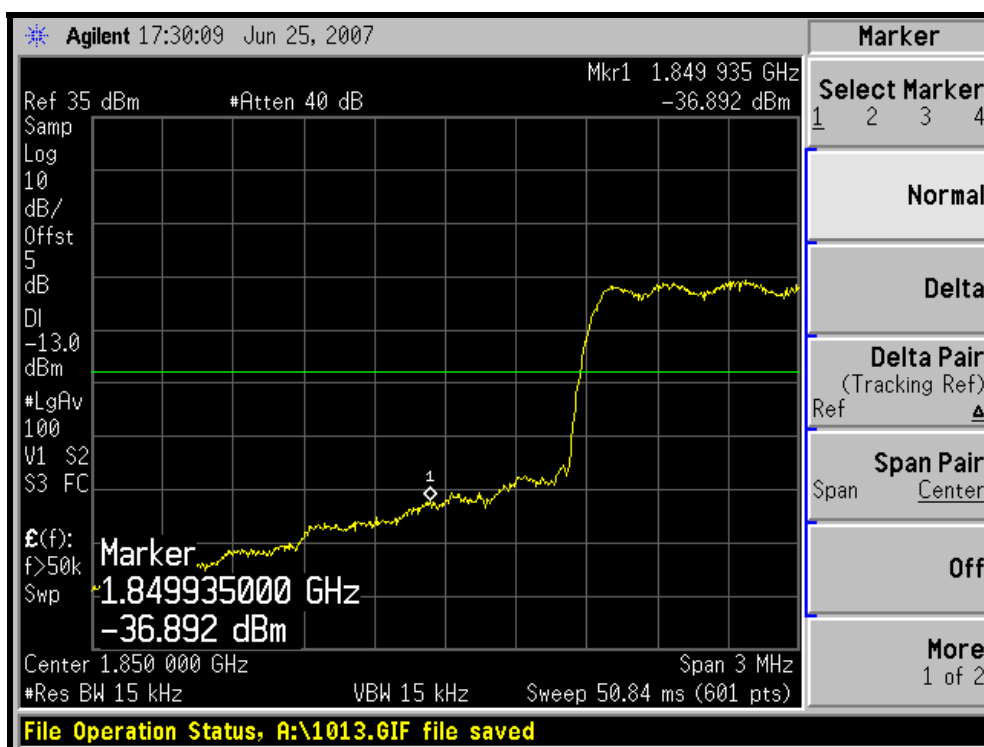

HIGHER BAND EDGE

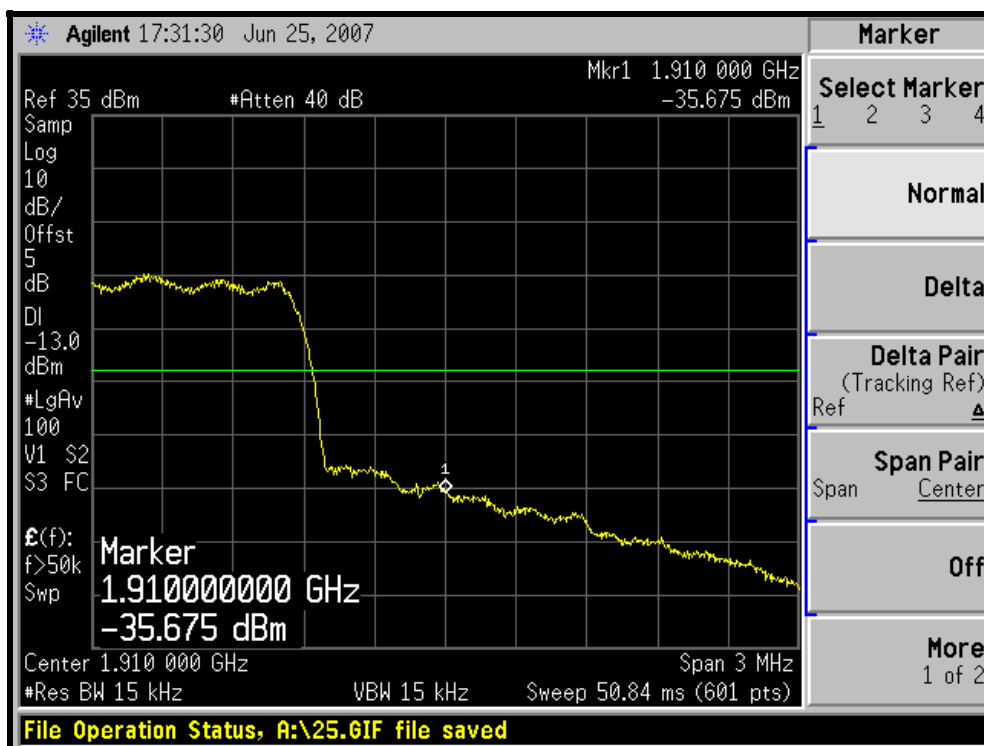



4.5 CONDUCTED SPURIOUS EMISSIONS

4.5.1 LIMITS OF CONDUCTED SPURIOUS EMISSIONS MEASUREMENT

In the FCC 24.238(a), On any frequency outside a licensee's frequency block within USPCS spectrum, the power of any emission shall be attenuated below the transmitter power (P) by at least $43 + 10 \log (P)$ dB. The specified minimum attenuation becomes 43dB and the limit of emission equal to -13dBm .

4.5.2 TEST INSTRUMENTS

| DESCRIPTION & MANUFACTURER | MODEL NO. | SERIAL NO. | CALIBRATED UNTIL |
|--|-------------------------------------|------------|------------------|
| * ROHDE & SCHWARZ Spectrum Analyzer | FSP40 | 100035 | Mar. 25, 2008 |
| * Wainwright Instruments Band Reject Filter | WRCG1850/1910-18 30/1930-60/10SS | SN1 | NA |
| * Wainwright Instruments High Pass Filter | WHK3.1/18G-10SS | SN1 | NA |
| * Mini-Circuits Power Splitter | ZAPD-4 | 400005 | NA |
| * Hewlett Packard RF cable | 8120-6192 | 01428251 | NA |
| * JFW 20dB attenuation | 50HF-020-SMA | NA | NA |
| * Suhner RF cable | Sucoflex104 | 204850/4 | NA |

- NOTE:**
1. The calibration interval of the above test instruments is 12 months. And the calibrations are traceable to NML/ROC and NIST/USA.
 2. "*" = These equipments are used for the final measurement.

4.5.3 TEST PROCEDURE

- a. The EUT was set up for the maximum peak power with CDMA link data modulation. The power was measured with R&S Spectrum Analyzer. All measurements were done at 3 channels, 25, 600 and 1175 (low, middle and high operational frequency range.)
- b. The conducted spurious emission used the power splitter via EUT RF power connector between simulation base station and spectrum analyzer. This splitter loss and cable loss are the worst loss 5dB in the transmitted path track.
- c. When the spectrum scanned from 9kHz to 3GHz, it shall be connected to the band reject filter attenuated the carried frequency. The spectrum set RB/VB 1MHz.
- d. When the spectrum scanned from 3GHz to 20GHz, it shall be connected to the high pass filter attenuated the carried frequency. The spectrum set RB/VB 1MHz.

4.5.4 TEST SETUP

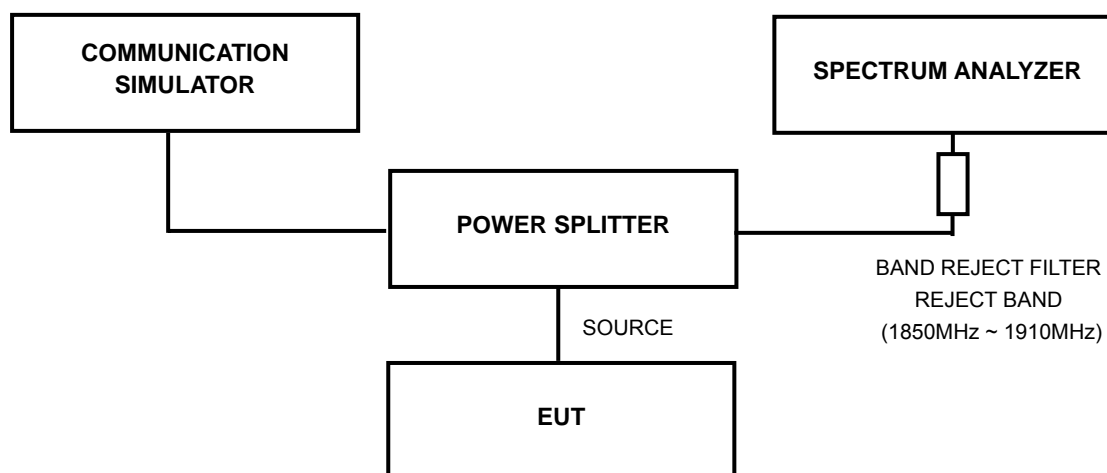

4.5.5 EUT OPERATING CONDITIONS

- a. The EUT makes a phone call to the communication simulator.
- b. The communication simulator station system controlled a EUT to export maximum output power under transmission mode and specific channel frequency.

4.5.6 TEST RESULTS

CH 25: 9kHz ~ 3GHz

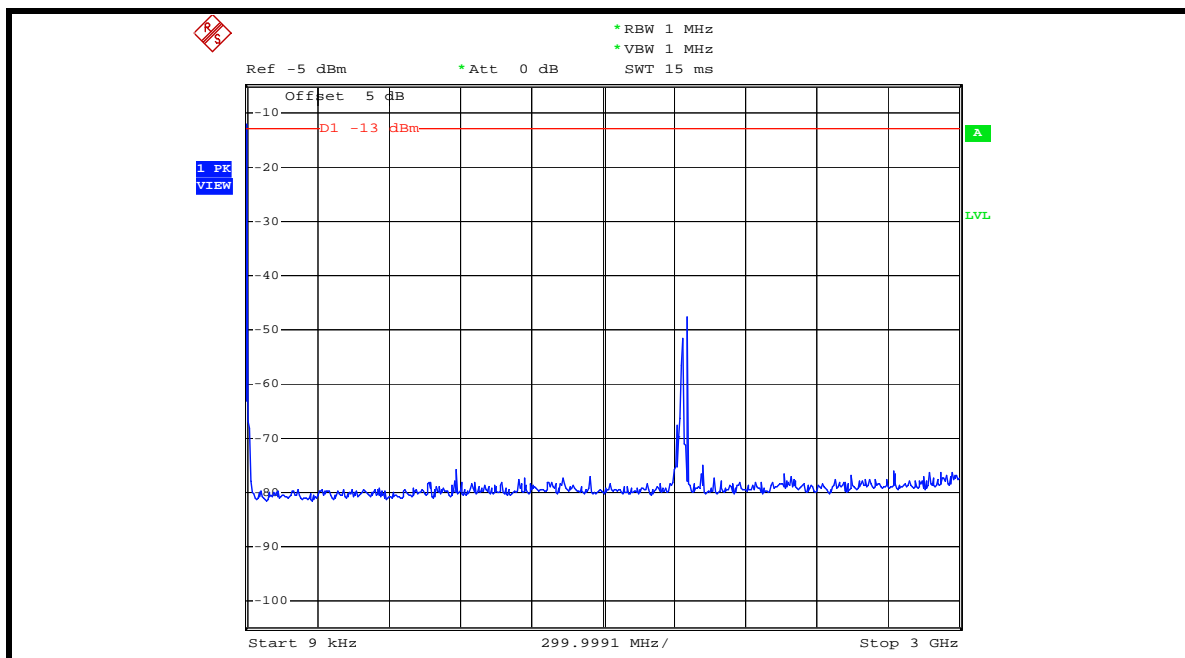

3GHz ~ 10GHz

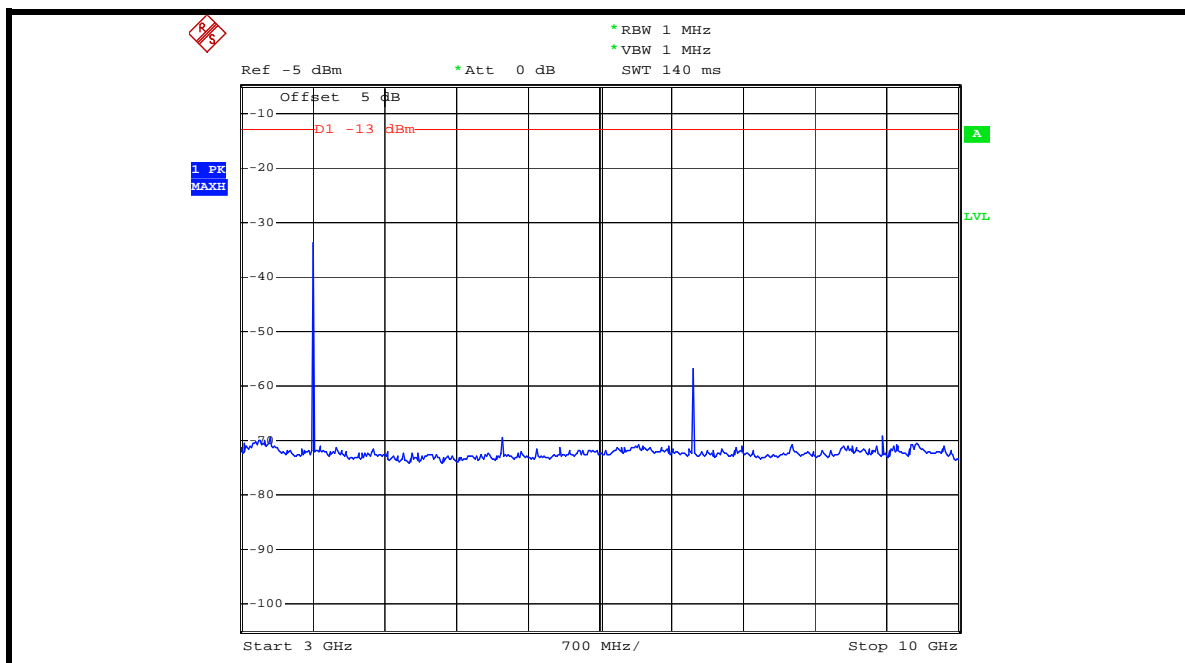

10GHz ~ 20GHz

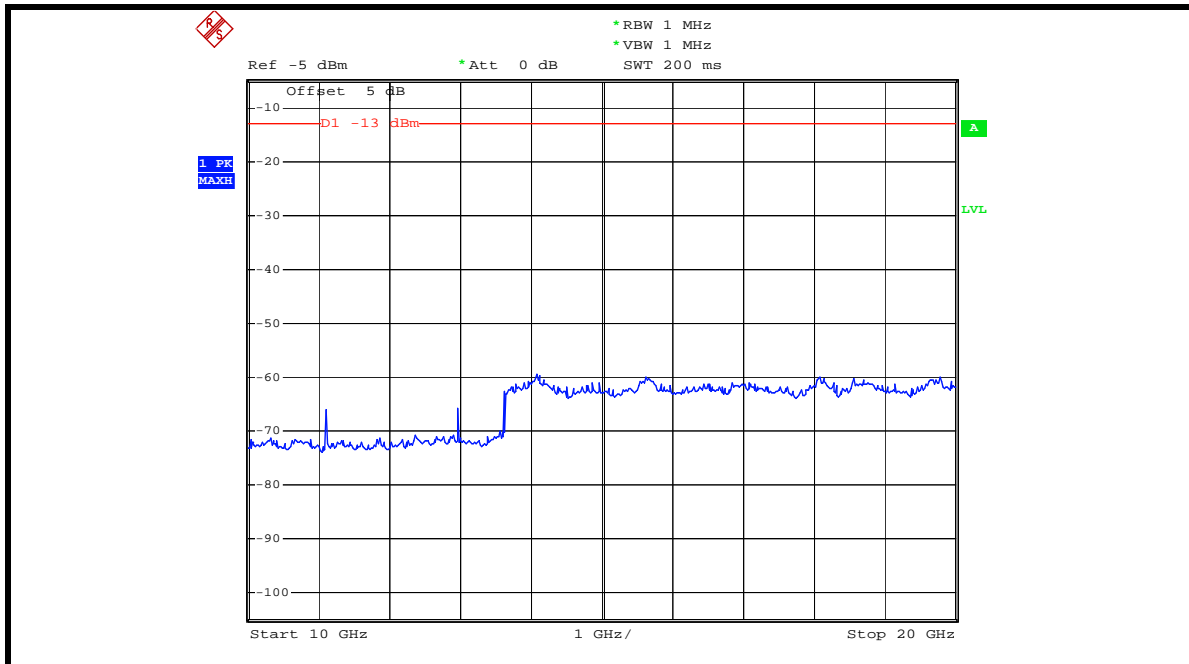

CH 600: 9kHz ~ 3GHz

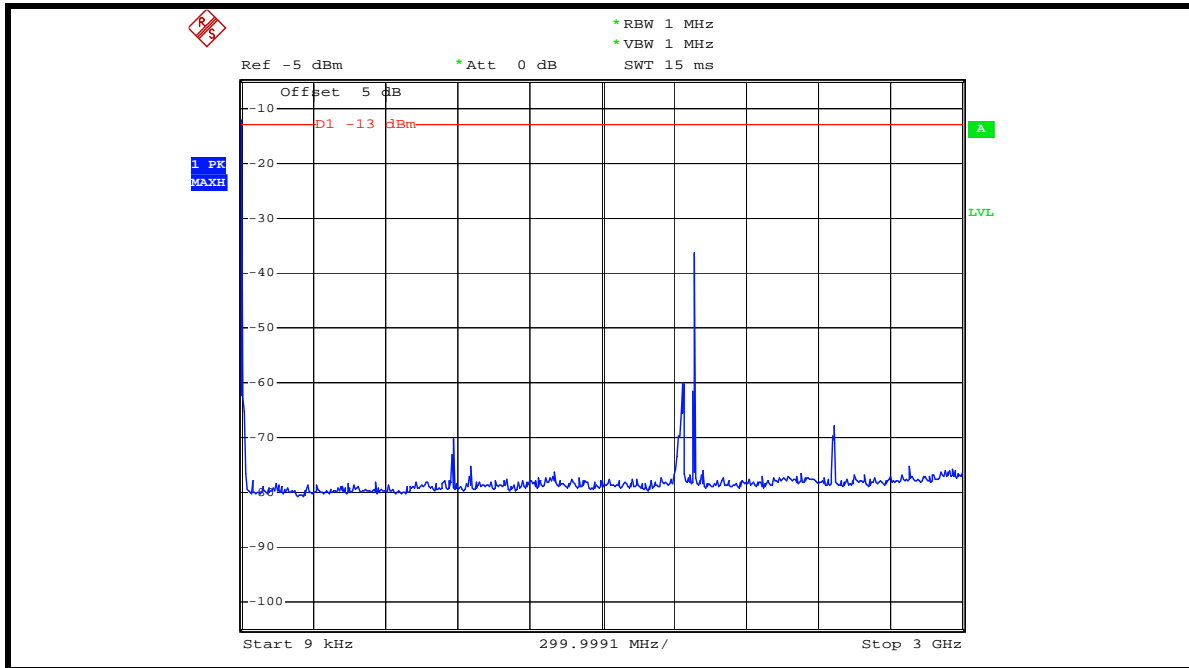

3GHz ~ 10GHz

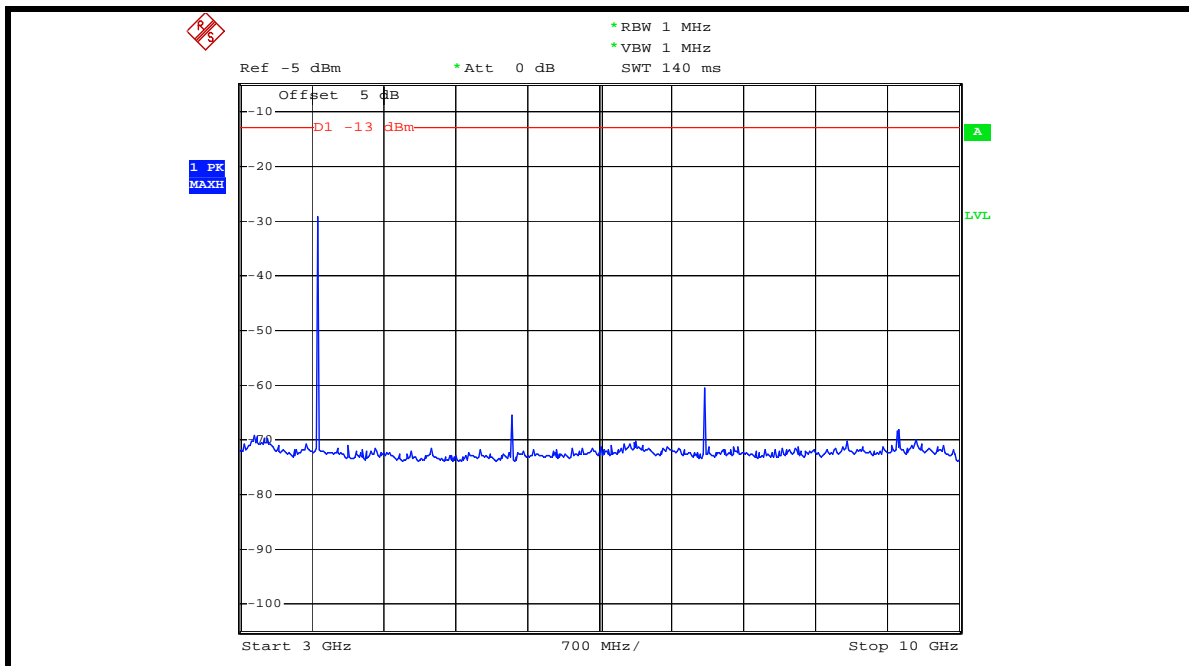

10GHz ~ 20GHz

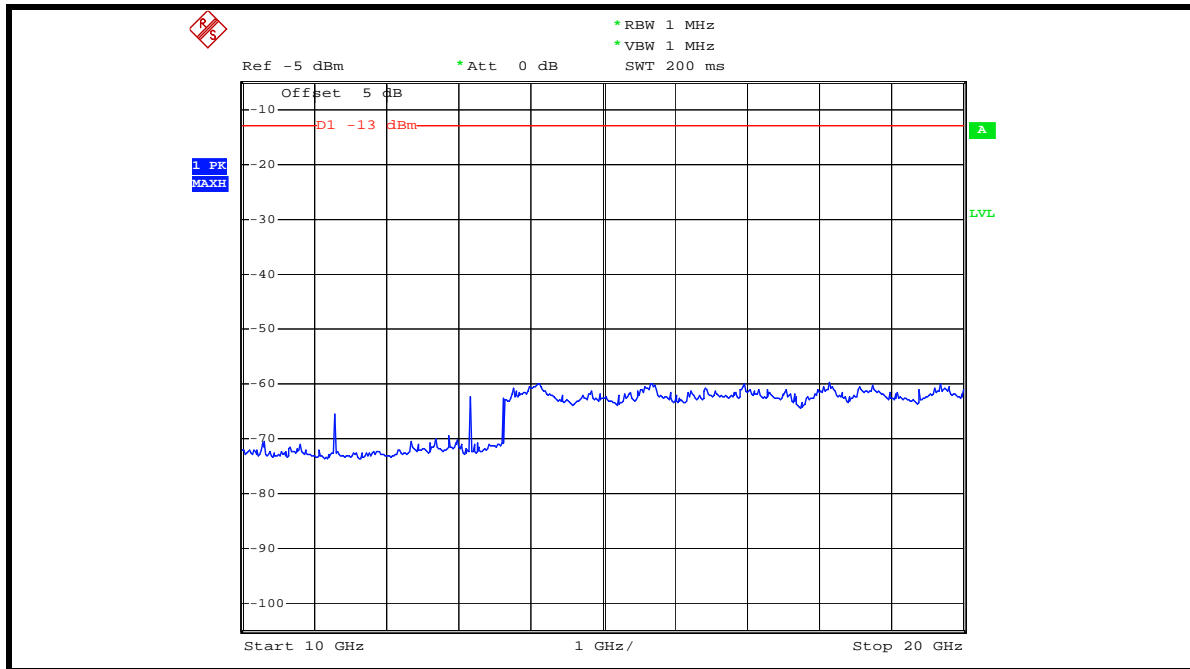

CH 1175: 9kHz ~ 3GHz

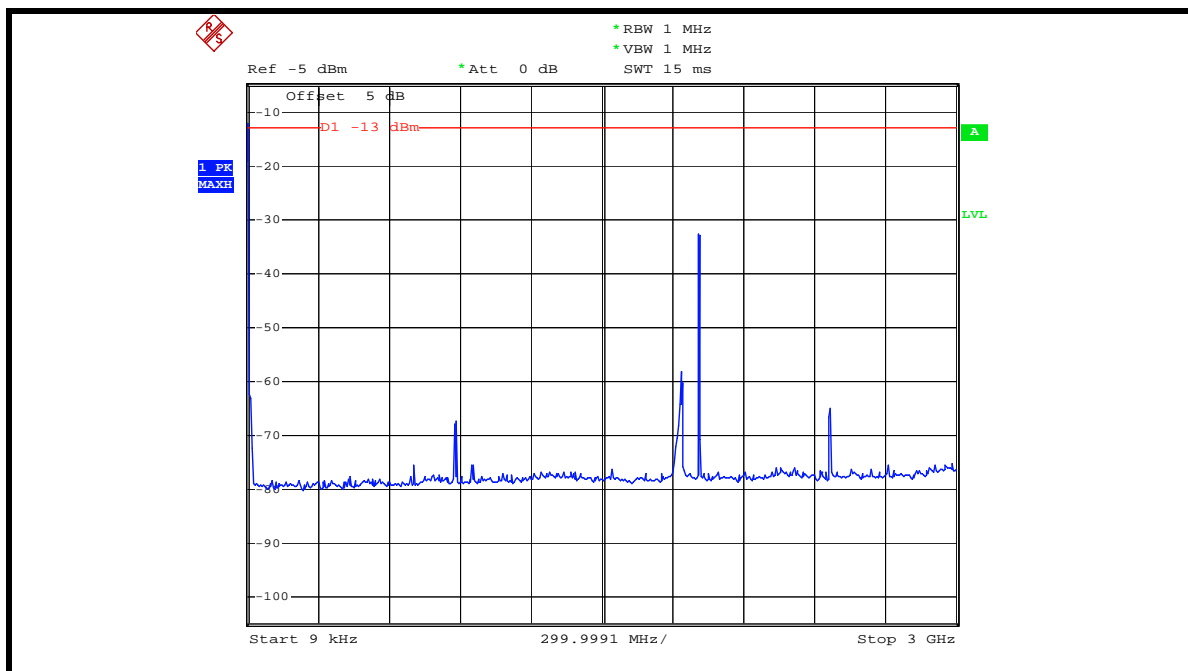

3GHz ~ 10GHz

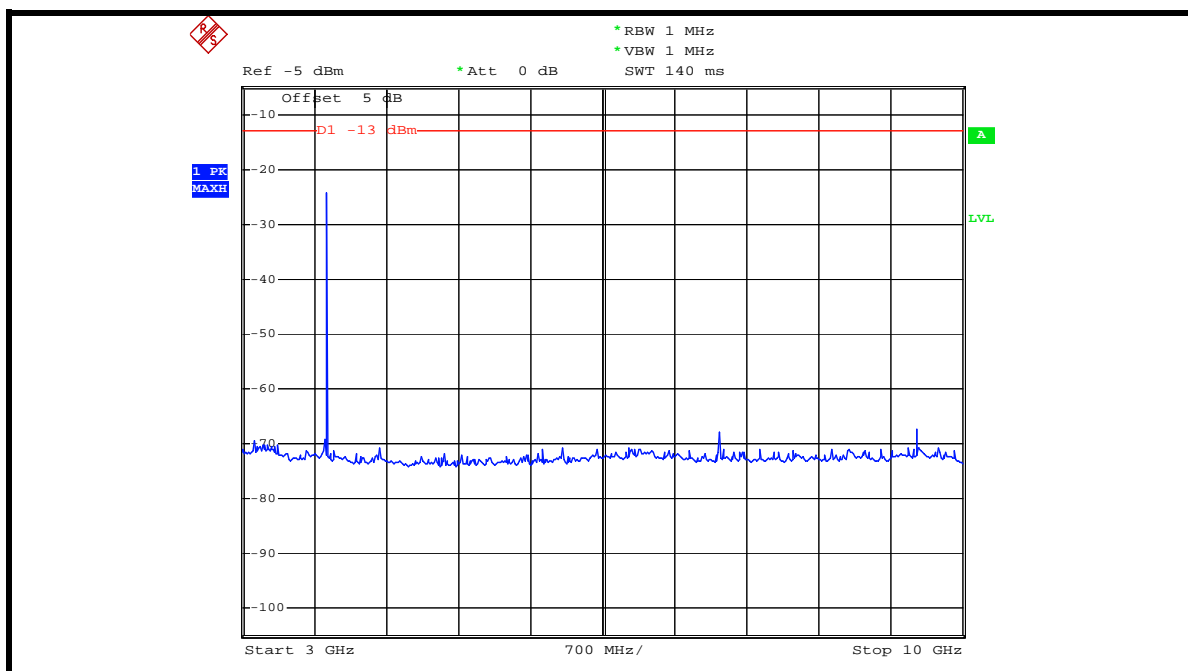

10GHz ~ 20GHz

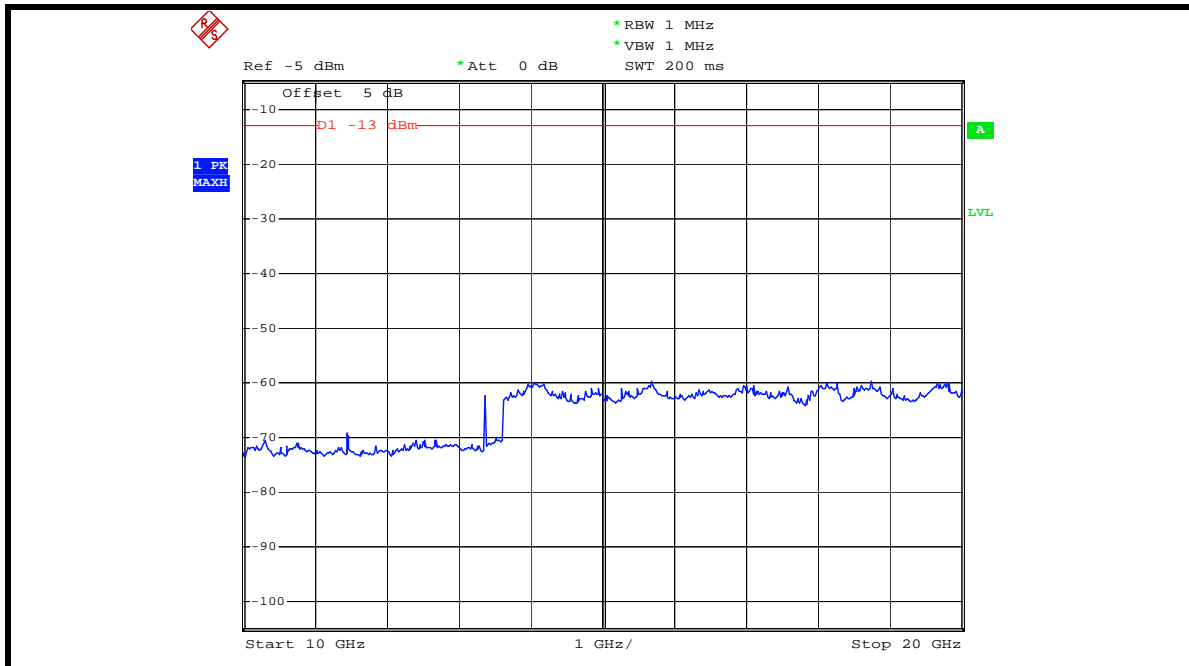

4.6 RADIATED EMISSION MEASUREMENT (BELOW 1GHz)

4.6.1 LIMITS OF RADIATED EMISSION MEASUREMENT

In the FCC 24.238(a), On any frequency outside a licensee's frequency block within USPCS spectrum, the power of any emission shall be attenuated below the transmitter power (P) by at least $43 + 10 \log (P)$ dB. The specified minimum attenuation becomes 43dB and the limit of emission equal to -13 dBm. So the limit of emission is the same absolute specified line.

| LIMIT (dBm) | EQUIVALENT FIELD STRENGTH AT 3m (dBuV/m) (NOTE) |
|-------------|---|
| -13 | 82.22 |

NOTE: The following formula is used to convert the equipment radiated power to field strength.

$$E = [1000000 \sqrt{(30P)}] / 3 \text{ uV/m, where P is Watts.}$$



4.6.2 TEST INSTRUMENTS

| DESCRIPTION & MANUFACTURER | MODEL NO. | SERIAL NO. | CALIBRATED UNTIL |
|---|-------------------|-------------|------------------|
| Test Receiver ROHDE & SCHWARZ | ESCI | 100424 | Aug 04, 2007 |
| Spectrum Analyzer ROHDE & SCHWARZ | FSP40 | 100025 | Oct. 05, 2007 |
| BILOG Antenna SCHWARZBECK | VULB9168 | 9168-160 | May 31, 2008 |
| HORN Antenna SCHWARZBECK | 9120D | 9120D-209 | Jun. 28, 2008 |
| HORN Antenna SCHWARZBECK | BBHA 9170 | BBHA9170243 | Dec. 28, 2007 |
| Preamplifier Agilent | 8447D | 2944A10633 | Oct. 26, 2007 |
| Preamplifier Agilent | 8449B | 3008A01964 | Oct. 26, 2007 |
| RF signal cable HUBER+SUHNNER | SUCOFLEX 104 | 238137/4 | Dec. 11, 2007 |
| RF signal cable HUBER+SUHNNER | SUCOFLEX 104 | 233233/4 | Nov. 14, 2007 |
| Software ADT. | ADT_Radiated_V7.6 | NA | NA |
| Antenna Tower inn-co GmbH | MA 4000 | 013303 | NA |
| Antenna Tower Controller inn-co GmbH | CO2000 | 017303 | NA |
| Turn Table ADT. | TT100. | TT93021703 | NA |
| Turn Table Controller ADT. | SC100. | SC93021703 | NA |
| Signal Generator Agilent | E8257C | MY43320668 | Dec. 28, 2007 |

- NOTE:**
1. The calibration interval of the above test instruments is 12 months and the calibrations are traceable to NML/ROC and NIST/USA.
 2. The test was performed in HwaYa Chamber 3.
 3. The horn antenna and HP preamplifier (model: 8449B) are used only for the measurement of emission frequency above 1GHz if tested.
 4. The VCCI Site Registration No. is R-237.
 5. The IC Site Registration No. is IC3789B-3.

4.6.3 TEST PROCEDURES

- a. The EUT was placed on the top of a rotating table 0.8 meters above the ground. The table was rotated 360 degrees to determine the position of the highest radiation.
- b. The EUT was set 3 meters away from the receiving antenna, which was mounted on antenna tower and its position at 0.8 m above the ground.
- c. For each suspected emission, the EUT was arranged to its worst case and the rotatable table was turned from 0 degrees to 360 degrees to find the maximum reading and recorded the value.
- d. Repeat step a ~ c for horizontal polarization.

NOTE: The resolution bandwidth of spectrum analyzer is 1 MHz and the video bandwidth is 1 MHz.

4.6.4 DEVIATION FROM TEST STANDARD

No deviation

4.6.5 TEST SETUP

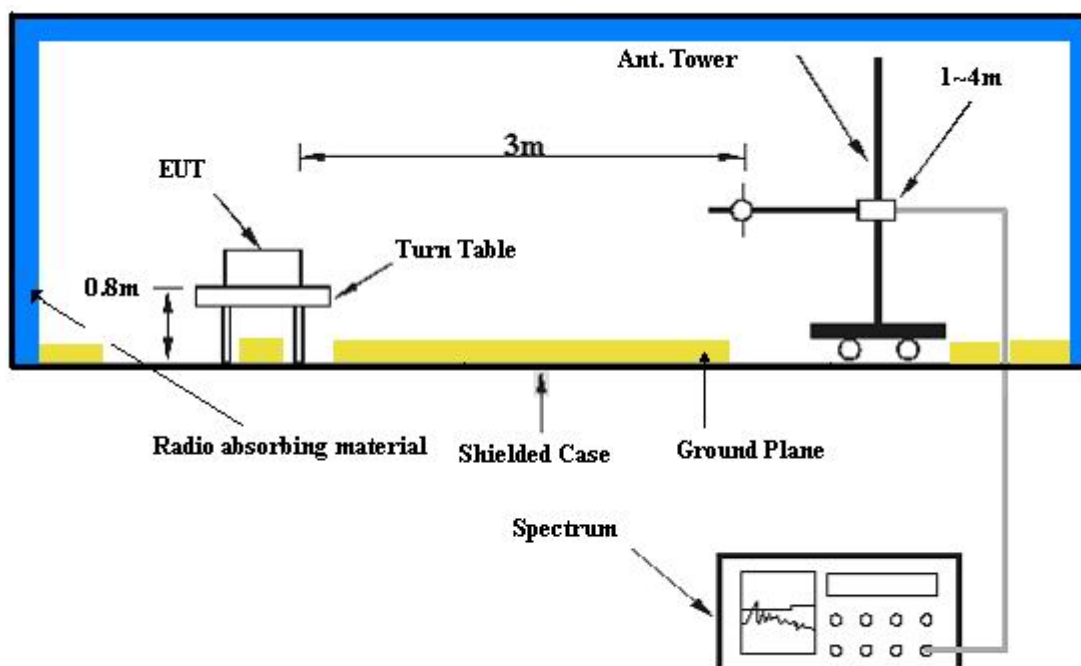

For the actual test configuration, please refer to the attached file (Test Setup Photo).

4.6.6 EUT OPERATING CONDITIONS

- a. The EUT makes a phone call to the communication simulator.
- b. The communication simulator station system controlled an EUT to export maximum output power under transmission mode and specific channel frequency.



4.6.7 TEST RESULTS

| | | | |
|---------------------------------|-------------------------|-----------------------------|--------------|
| MODE | TX channel 25 | DETECTOR FUNCTION | Quasi-Peak |
| FREQUENCY RANGE | Below 1000MHz | INPUT POWER (SYSTEM) | 120Vac, 60Hz |
| ENVIRONMENTAL CONDITIONS | 24deg. C, 68%RH, 991hPa | TESTED BY | Match Tsui |

| ANTENNA POLARITY & TEST DISTANCE: HORIZONTAL AT 3 M | | | | | | | | |
|---|-------------|-------------------------|----------------|-------------|--------------------|----------------------|------------------|--------------------------|
| NO. | FREQ. (MHz) | EMISSION LEVEL (dBuV/m) | LIMIT (dBuV/m) | MARGIN (dB) | ANTENNA HEIGHT (m) | TABLE ANGLE (Degree) | RAW VALUE (dBuV) | CORRECTION FACTOR (dB/m) |
| 1 | 718.18 | 24.03 QP | 82.22 | -58.19 | 1.50 H | 208.00 | -0.69 | 24.72 |
| 2 | 749.29 | 27.18 QP | 82.22 | -55.04 | 1.00 H | 283.00 | 1.55 | 25.63 |
| 3 | 766.79 | 25.27 QP | 82.22 | -56.95 | 1.00 H | 10.00 | -0.46 | 25.73 |
| 4 | 807.62 | 26.72 QP | 82.22 | -55.50 | 1.50 H | 313.00 | 0.68 | 26.05 |
| 5 | 825.11 | 28.52 QP | 82.22 | -53.70 | 1.50 H | 7.00 | 2.09 | 26.42 |
| 6 | 873.72 | 27.50 QP | 82.22 | -54.72 | 1.00 H | 22.00 | 0.24 | 27.26 |
| 7 | 906.77 | 27.71 QP | 82.22 | -54.51 | 2.00 H | 304.00 | 0.01 | 27.70 |
| 8 | 937.88 | 28.19 QP | 82.22 | -54.03 | 1.50 H | 196.00 | 0.04 | 28.14 |

| ANTENNA POLARITY & TEST DISTANCE: VERTICAL AT 3 M | | | | | | | | |
|---|-------------|-------------------------|----------------|-------------|--------------------|----------------------|------------------|--------------------------|
| NO. | FREQ. (MHz) | EMISSION LEVEL (dBuV/m) | LIMIT (dBuV/m) | MARGIN (dB) | ANTENNA HEIGHT (m) | TABLE ANGLE (Degree) | RAW VALUE (dBuV) | CORRECTION FACTOR (dB/m) |
| 1 | 681.24 | 24.31 QP | 82.22 | -57.91 | 1.50 V | 196.00 | 0.34 | 23.97 |
| 2 | 743.45 | 24.78 QP | 82.22 | -57.44 | 2.00 V | 127.00 | -0.68 | 25.46 |
| 3 | 760.95 | 24.83 QP | 82.22 | -57.39 | 2.50 V | 109.00 | -0.87 | 25.70 |
| 4 | 805.67 | 25.69 QP | 82.22 | -56.53 | 1.50 V | 136.00 | -0.32 | 26.01 |
| 5 | 825.11 | 32.25 QP | 82.22 | -49.97 | 1.00 V | 355.00 | 5.82 | 26.42 |
| 6 | 871.78 | 26.87 QP | 82.22 | -55.35 | 1.00 V | 289.00 | -0.37 | 27.24 |
| 7 | 893.16 | 27.50 QP | 82.22 | -54.72 | 1.50 V | 280.00 | -0.01 | 27.51 |
| 8 | 937.88 | 28.22 QP | 82.22 | -54.00 | 2.00 V | 301.00 | 0.07 | 28.14 |

NOTE:

1. Emission level (dBuV/m) = Raw Value (dBuV) + Correction Factor (dB).
2. Correction Factor (dB/m) = Antenna Factor (dB/m) + Cable Factor (dB).
3. The other emission levels were very low against the limit.
4. Margin value = Emission level – Limit value.
5. This is valid for all 3 channels.



4.7 EFFECTIVE RADIATED POWER MEASUREMENT (ABOVE 1GHz)

4.7.1 LIMITS OF RADIATED EMISSION MEASUREMENT

In the FCC 24.238(a), On any frequency outside a licensee's frequency block within USPCS spectrum, the power of any emission shall be attenuated below the transmitter power (P) by at least $43 + 10 \log (P)$ dB. The specified minimum attenuation becomes 43dB and the limit of emission equal to -13dBm .



4.7.2 TEST INSTRUMENTS

| DESCRIPTION & MANUFACTURER | MODEL NO. | SERIAL NO. | CALIBRATED UNTIL |
|---|-------------------|-------------|------------------|
| Test Receiver ROHDE & SCHWARZ | ESCI | 100424 | Aug 04, 2007 |
| Spectrum Analyzer ROHDE & SCHWARZ | FSP40 | 100025 | Oct. 05, 2007 |
| BILOG Antenna SCHWARZBECK | VULB9168 | 9168-160 | May 31, 2008 |
| HORN Antenna SCHWARZBECK | 9120D | 9120D-209 | Jun. 28, 2008 |
| HORN Antenna SCHWARZBECK | BBHA 9170 | BBHA9170243 | Dec. 28, 2007 |
| Preamplifier Agilent | 8447D | 2944A10633 | Oct. 26, 2007 |
| Preamplifier Agilent | 8449B | 3008A01964 | Oct. 26, 2007 |
| RF signal cable HUBER+SUHNNER | SUCOFLEX 104 | 238137/4 | Dec. 11, 2007 |
| RF signal cable HUBER+SUHNNER | SUCOFLEX 104 | 233233/4 | Nov. 14, 2007 |
| Software ADT. | ADT_Radiated_V7.6 | NA | NA |
| Antenna Tower inn-co GmbH | MA 4000 | 013303 | NA |
| Antenna Tower Controller inn-co GmbH | CO2000 | 017303 | NA |
| Turn Table ADT. | TT100. | TT93021703 | NA |
| Turn Table Controller ADT. | SC100. | SC93021703 | NA |
| Signal Generator Agilent | E8257C | MY43320668 | Dec. 28, 2007 |

- NOTE:**
1. The calibration interval of the above test instruments is 12 months and the calibrations are traceable to NML/ROC and NIST/USA.
 2. The test was performed in HwaYa Chamber 3.
 3. The horn antenna and HP preamplifier (model: 8449B) are used only for the measurement of emission frequency above 1GHz if tested.
 4. The VCCI Site Registration No. is R-237.
 5. The IC Site Registration No. is IC3789B-3.

4.7.3 TEST PROCEDURES

- a. The EUT was placed on the top of a rotating table 0.8 meters above the ground. The table was rotated 360 degrees to determine the position of the highest radiation.
- b. The EUT was set 3 meters away from the receiving antenna, which was mounted on antenna tower and its position at 0.8 m above the ground.
- c. For each suspected emission, the EUT was arranged to its worst case and the rotatable table was turned from 0 degrees to 360 degrees to find the maximum reading and recorded the value.
- d. The EUT is replaced by a horn antenna connected to a signal generator tuned to the frequency of emission.
- e. The signal generator level has to be adjusted to have the same emission nature.
- f. The radiated power can be calculated via the factor and antenna gain.
- g. Repeat step a ~ f for horizontal polarization.

NOTE: The resolution bandwidth of spectrum analyzer is 1 MHz and the video bandwidth is 1 MHz.

4.7.4 DEVIATION FROM TEST STANDARD

No deviation

4.7.5 TEST SETUP

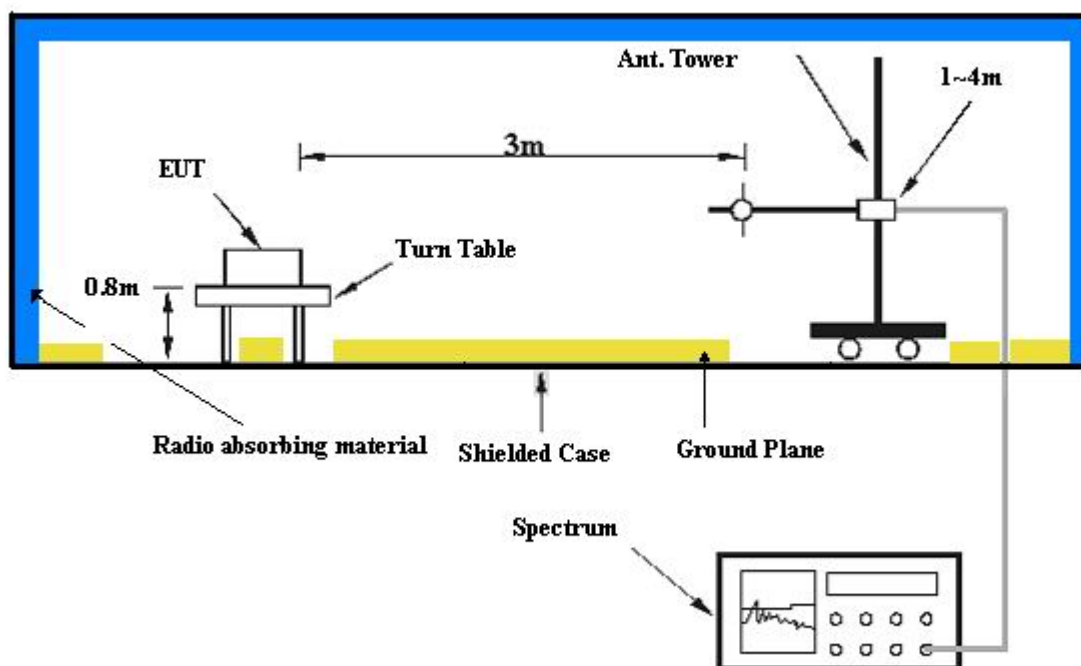

For the actual test configuration, please refer to the attached file (Test Setup Photo).

4.7.6 EUT OPERATING CONDITIONS

- a. The EUT makes a phone call to the communication simulator.
- b. The communication simulator station system controlled an EUT to export maximum output power under transmission mode and specific channel frequency.



4.7.7 TEST RESULTS

| | | | |
|-----------------------------|--------------|---------------------------------|-------------------------|
| MODE | Channel 25 | FREQUENCY RANGE | Above 1000MHz |
| INPUT POWER (SYSTEM) | 120Vac, 60Hz | ENVIRONMENTAL CONDITIONS | 25deg. C, 71%RH, 983hPa |
| TESTED BY | Lori Chiu | | |

| ANTENNA POLARITY & TEST DISTANCE: HORIZONTAL AT 3 M | | | | | | |
|---|-------------|-----------------------|-------------|-----------------------|------------------------|-------------------|
| NO. | FREQ. (MHz) | EMISSION LEVEL (dBuV) | LIMIT (dBm) | S.G POWER VALUE (dBm) | CORRECTION FACTOR (dB) | POWER VALUE (dBm) |
| 1 | 3702.50 | 53.14 | -13.00 | -52.21 | 10.12 | -42.09 |
| 2 | 5553.75 | 49.63 | -13.00 | -57.09 | 11.49 | -45.60 |
| 3 | 7405.00 | 56.26 | -13.00 | -51.47 | 12.50 | -38.97 |

| ANTENNA POLARITY & TEST DISTANCE: VERTICAL AT 3 M | | | | | | |
|---|-------------|-----------------------|-------------|-----------------------|------------------------|-------------------|
| NO. | FREQ. (MHz) | EMISSION LEVEL (dBuV) | LIMIT (dBm) | S.G POWER VALUE (dBm) | CORRECTION FACTOR (dB) | POWER VALUE (dBm) |
| 1 | 3702.50 | 49.52 | -13.00 | -55.83 | 10.12 | -45.71 |
| 2 | 5553.75 | 47.67 | -13.00 | -59.05 | 11.49 | -47.56 |
| 3 | 7405.00 | 60.67 | -13.00 | -47.06 | 12.50 | -34.56 |

NOTE: Power Value (dBm) = S.G Power Value (dBm) + Correction Factor (dB).



| | | | |
|-----------------------------|--------------|---------------------------------|-------------------------|
| MODE | Channel 600 | FREQUENCY RANGE | Above 1000MHz |
| INPUT POWER (SYSTEM) | 120Vac, 60Hz | ENVIRONMENTAL CONDITIONS | 25deg. C, 71%RH, 983hPa |
| TESTED BY | Lori Chiu | | |

| ANTENNA POLARITY & TEST DISTANCE: HORIZONTAL AT 3 M | | | | | | |
|--|--------------------|------------------------------|--------------------|------------------------------|-------------------------------|--------------------------|
| NO. | FREQ. (MHz) | EMISSION LEVEL (dBuV) | LIMIT (dBm) | S.G POWER VALUE (dBm) | CORRECTION FACTOR (dB) | POWER VALUE (dBm) |
| 1 | 3760.00 | 60.67 | -13.00 | -44.68 | 10.12 | -34.56 |
| 2 | 5640.00 | 51.20 | -13.00 | -55.52 | 11.49 | -44.03 |
| 3 | 7520.00 | 56.76 | -13.00 | -50.97 | 12.50 | -38.47 |

| ANTENNA POLARITY & TEST DISTANCE: VERTICAL AT 3 M | | | | | | |
|--|--------------------|------------------------------|--------------------|------------------------------|-------------------------------|--------------------------|
| NO. | FREQ. (MHz) | EMISSION LEVEL (dBuV) | LIMIT (dBm) | S.G POWER VALUE (dBm) | CORRECTION FACTOR (dB) | POWER VALUE (dBm) |
| 1 | 3760.00 | 60.16 | -13.00 | -45.19 | 10.12 | -35.07 |
| 2 | 5640.00 | 49.30 | -13.00 | -57.42 | 11.49 | -45.93 |
| 3 | 7520.00 | 58.18 | -13.00 | -49.55 | 12.50 | -37.05 |

NOTE: Power Value (dBum) = S.G Power Value (dBm) + Correction Factor (dB).



| | | | |
|-----------------------------|--------------|---------------------------------|-------------------------|
| MODE | Channel 1175 | FREQUENCY RANGE | Above 1000MHz |
| INPUT POWER (SYSTEM) | 120Vac, 60Hz | ENVIRONMENTAL CONDITIONS | 25deg. C, 71%RH, 983hPa |
| TESTED BY | Lori Chiu | | |

| ANTENNA POLARITY & TEST DISTANCE: HORIZONTAL AT 3 M | | | | | | |
|--|--------------------|------------------------------|--------------------|------------------------------|-------------------------------|--------------------------|
| NO. | FREQ. (MHz) | EMISSION LEVEL (dBuV) | LIMIT (dBm) | S.G POWER VALUE (dBm) | CORRECTION FACTOR (dB) | POWER VALUE (dBm) |
| 1 | 3817.50 | 65.84 | -13.00 | -39.51 | 10.12 | -29.39 |
| 2 | 5726.25 | 56.77 | -13.00 | -49.95 | 11.49 | -38.46 |
| 3 | 7635.00 | 57.50 | -13.00 | -50.23 | 12.50 | -37.73 |

| ANTENNA POLARITY & TEST DISTANCE: VERTICAL AT 3 M | | | | | | |
|--|--------------------|------------------------------|--------------------|------------------------------|-------------------------------|--------------------------|
| NO. | FREQ. (MHz) | EMISSION LEVEL (dBuV) | LIMIT (dBm) | S.G POWER VALUE (dBm) | CORRECTION FACTOR (dB) | POWER VALUE (dBm) |
| 1 | 3817.50 | 64.57 | -13.00 | -40.78 | 10.12 | -30.66 |
| 2 | 5726.25 | 55.58 | -13.00 | -51.14 | 11.49 | -39.65 |
| 3 | 7635.00 | 58.69 | -13.00 | -49.04 | 12.50 | -36.54 |

NOTE: Power Value (dBum) = S.G Power Value (dBm) + Correction Factor (dB).



5 INFORMATION ON THE TESTING LABORATORIES

We, ADT Corp., were founded in 1988 to provide our best service in EMC, Radio, Telecom and Safety consultation. Our laboratories are accredited and approved by the following approval agencies according to ISO/IEC 17025.

| | |
|--------------------|-----------------------|
| USA | FCC, UL, A2LA |
| GERMANY | TUV Rheinland |
| JAPAN | VCCI |
| NORWAY | NEMKO |
| CANADA | INDUSTRY CANADA , CSA |
| R.O.C. | TAF, BSMI, NCC |
| NETHERLANDS | Telefication |
| SINGAPORE | PSB , GOST-ASIA (MOU) |
| RUSSIA | CERTIS (MOU) |

Copies of accreditation certificates of our laboratories obtained from approval agencies can be downloaded from our web site: www.adt.com.tw/index.5/phtml.
If you have any comments, please feel free to contact us at the following:

Linko EMC/RF Lab:
Tel: 886-2-26052180
Fax: 886-2-26051924

Hsin Chu EMC/RF Lab:
Tel: 886-3-5935343
Fax: 886-3-5935342

Hwa Ya EMC/RF/Safety/Telecom Lab: Web Site: www.adt.com.tw
Tel: 886-3-3183232
Fax: 886-3-3185050

The address and road map of all our labs can be found in our web site also.



6 APPENDIX A – MODIFICATIONS RECORDERS FOR ENGINEERING CHANGES TO THE EUT BY THE LAB

No any modifications are made to the EUT by the lab during the test.