



# A Test Lab Techno Corp.

Changan Lab : No. 140 -1, Changan Street, Bade City, Taoyuan County, Taiwan R.O.C.  
Tel : +886-3-271-0188 / Fax : +886-3-271-0190



## HAC EVALUATION REPORT

<b>Test Report No. :</b>	<b>06-0200-H-00-02-05</b>
<b>Applicant :</b>	<b>High Tech Computer Corp.</b>
<b>Model Name :</b>	<b>TITA100</b>
<b>FCC ID :</b>	<b>NM8TITA100</b>
<b>EUT Type :</b>	<b>Pocket PC Phone</b>
<b>Dates of Test :</b>	<b>Oct. 09 - 21, Dec. 13-27, 2006</b>
<b>Test Environment :</b>	<b>Ambient Temperature : 22 ± 3 °C</b> <b>Relative Humidity : 40 - 70 %</b>
<b>FCC Rule Part(s)</b>	<b>FCC 47 CFR § 20.19.</b> <b>FCC 47 CFR § 2.1033d</b>
<b>HAC Standard :</b>	<b>ANSI PC63.19-2006</b>
<b>PC63.19 HAC Rated Category:</b>	<b>M3 (RF EMISSIONS)</b>
<b>Test Lab :</b>	<b>Changan Lab</b>

1. The test operations have to be performed with cautious behavior, the test results are as attached.
2. The test results are under chamber environment of A Test Lab Techno Corp. A Test Lab Techno Corp. does not assume responsibility for any conclusions and generalizations drawn from the test results with regard to other specimens or samples.
3. The measurement report has to be written approval of A Test Lab Techno Corp. It may only be reproduced or published in ful

  
**Country Huang** 20061227  
**Testing Center Manager**  
**A Test Lab Techno Corp.**

  
**Sam Chuang** 20061227  
**Testing Engineer**



# Contents

<b>1. Description of Equipment Under Test (EUT)</b> .....	<b>3</b>
<b>2. Introduction</b> .....	<b>4</b>
<b>3. Test Equipment List</b> .....	<b>5</b>
<b>4. Validation</b> .....	<b>6</b>
<b>5. Probe Modulation Factor</b> .....	<b>8</b>
<b>6. Test Results</b> .....	<b>11</b>
<b>7. Test Results</b> .....	<b>12</b>
7.1 HAC E-Field measurement results .....	14
7.1.1 TITA100 - Mode 1 measurement results.....	15
7.1.2 TITA100 - Mode 2 measurement results.....	16
7.2 HAC H-Field measurement results .....	17
7.2.1 TITA100 - Mode 1 measurement results.....	18
7.2.2 TITA100 - Mode 2 measurement results.....	19
<b>Appendix A - Details of WD signal</b> .....	<b>20</b>
<b>Appendix B - Validation</b> .....	<b>24</b>
<b>Appendix C - TITA100 - Mode 1 HAC distribution plots for E-Field and H-Field</b> .....	<b>49</b>
<b>Appendix D – TITA100 - Mode 2 HAC distribution plots for E-Field and H-Field</b> .....	<b>110</b>
<b>Appendix E - Calibration</b> .....	<b>171</b>



## 1. Description of Equipment Under Test (EUT)

Applicant :

**High Tech Computer Corp.**  
1F, No.6-3, Baoqiang Rd., Xindian City, Taipei Country 231, Taiwan, R.O.C

**EUT Type** : Pocket PC Phone  
**Model Name** : TITA100  
**FCC ID** : NM8TITA100  
**Tx Frequency** : 824MHz - 849MHz (CDMA 850)  
1851MHz - 1909MHz (CDMA 1900)  
2412MHz - 2462MHz (802.11b DSSS / 802.11g OFDM)  
**Max. Output Power** : 23.25 dBm CDMA 850  
23.60 dBm CDMA 1900  
19.05 dBm 802.11b DSSS  
19.05 dBm 802.11g OFDM  
**HW Version** : XC  
**SW Version** : CE-0.51.00.00,RS-0.95.00  
**Antenna Type** : Internal Type (Antenna Gain = 0 dBi)  
**Test Device** : Identical Prototype  
**Device Category** : Portable

This wireless portable device has performed Hearing Aid Compatibility (HAC) measurements for the portable cellular phone. The measurements were performed to ensure compliance to the ANSI PC63.19-2001 rd 3.12 standards, which is the same as the ANSI C63.19-2006 per the FCC public notice DA 06-1215.



## **2. Introduction**

The A Test Lab Techno Corp. has performed measurements of the maximum potential exposure to the user of **High Tech Computer Corp. Model(s) : TITA100**. The test procedures, as described in ANSI PC63.19-2006 standard were employed. A description of the product and operating configuration, detailed summary of the test results, methodology and procedures used in the equipment are included within this test report.



### 3. Test Equipment List

Manufacturer	Name of Equipment	Type/Model	Serial Number	Calibration	
				Last Cal.	Due Date
SPEAG	Dosimetric E-Filed Probe	ER3DV6	2256	Oct, 21, 2005	Oct, 21, 2007
SPEAG	Dosimetric H-Filed Probe	H3DV6	6076	Oct. 21, 2005	Oct, 21, 2007
SPEAG	835 MHz System Validation Kit	CD835V3	1017	Sep. 15, 2005	Sep. 15, 2007
SPEAG	1880 MHz System Validation Kit	CD1880V3	1036	Sep. 13, 2005	Sep. 13, 2007
SPEAG	2450 MHz System Validation Kit	CD2450V3	1037	Sep. 08, 2005	Sep. 08, 2007
SPEAG	Data Acquisition Electronics	DAE3	393	Sep. 05, 2006	Sep. 05, 2007
SPEAG	Device Holder	N/A	N/A	NCR	NCR
SPEAG	HAC Test Arch	SD-HAC-P01-BA	1038	NCR	NCR
SPEAG	Robot	Staubli RX90L	F00/589B1/A/01	NCR	NCR
SPEAG	Software	DASY4 V4.7 Build 44	N/A	NCR	NCR
SPEAG	Software	SEMCAD V1.8 Build 171	N/A	NCR	NCR
SPEAG	Measurement Server	SE UMS 001 BA	1021	NCR	NCR
Agilent	Wireless Communication Test Set	8960(E5515C)	GB41450409	Mar. 01, 2006	Mar. 01, 2007
Agilent	S-Parameter Network Analyzer	8720ES	US39172472	Aug. 15, 2006	Aug. 15, 2007
Agilent	Spectrum Analyzer(ESA-L)	E4408B	MY45107753	May. 03, 2006	May. 03, 2007
Agilent	Spectrum Analyzer(PSA)	E4445A	MY45300744	May. 09, 2006	May. 09, 2007
Agilent	Power Meter	E4418B	GB40206143	Apr. 24, 2006	Apr. 24, 2007
Agilent	Signal Generator	8648C	3847A05201	Jul. 06, 2006	Jul. 06, 2008
Agilent	Power Sensor	8481H	3318A20779	Apr. 25, 2006	Apr. 25, 2007
Agilent	Dual Directional Coupler	778D	50334	NCR	NCR
Mini-Circuits	Power Amplifier	ZVE-8G	D042005 671800514	NCR	NCR
Mini-Circuits	Power Amplifier	ZHL-42W-SMA	D111103#5	NCR	NCR

**Table 1. Test Equipment List**



#### 4. Validation

Validations of the DASY4 v4.7 test system were performed using the measurement equipment listed in Section 3.1. All validations occur in free space using the DASY4 test arch. Note that the 10mm probe to dipole separation is measured from the top edge of the dipole to the calibration reference point of the probe. SPEAG uses the center point of the probe sensor(s) as the reference point when establishing targets for their dipoles. Therefore, because SPEAG's dipoles and targets are used, it is appropriate to measure the 10mm separation distance to the center of the sensors as they do. This reference point was used for validation only. Validations were performed at 835 MHz and/or 1880 MHz. These frequencies are within each operating band and are within 2MHz of the mid-band frequency of the test device. The obtained results from the validations are displayed in the table below. The field contour plots are included in Appendix B.

Validations were performed to verify that measured E-field and H-field values are within +/- 25% from the target reference values provided by the manufacturer (Ref: Appendix C/D). Per Section 4.2.2.1 of the C63.19 standard, "Values within +/-25% are acceptable, of which 12% is deviation and 13% is measurement uncertainty." Therefore, the E-Field and H-Field dipole verification results, shown in Table 4, are in accordance with the acceptable parameters defined by the standard.

Dipole	Freq. (MHz)	Protocol	Input Power (mW)	E-Field Results (V/m)	Target for Dipole (V/m)	% Deviation	Date
SN:1017	835	CW	100	164.3	169.6	3.23	Oct. 09, 2006
					158.7	-3.41	Oct. 21, 2006
					170.1	3.53	Dec. 12, 2006
					178.3	8.52	Dec. 19, 2006
					182.1	10.83	Dec. 26, 2006
SN:1036	1880	CW	100	138.4	151.4	9.39	Oct. 09, 2006
					149.3	7.88	Oct. 21, 2006
					139.6	0.87	Dec. 12, 2006
					154.2	11.42	Dec. 19, 2006
					146.2	5.64	Dec. 26, 2006
SN:1037	2450	CW	100	132.6	144.2	8.75	Oct. 09, 2006
					147.5	11.24	Oct. 21, 2006

Table 2. Dipole E-Field Measurement Summary

Dipole	Freq. (MHz)	Protocol	Input Power (mW)	H-Field Results (A/m)	Target for Dipole (A/m)	% Deviation	Date
SN:1017	835	CW	100	0.443	0.469	5.87	Oct. 09, 2006
					0.441	-0.45	Oct. 21, 2006
					0.448	1.13	Dec. 12, 2006
					0.458	3.39	Dec. 19, 2006
					0.438	-1.13	Dec. 26, 2006
SN:1036	1880	CW	100	0.459	0.471	2.61	Oct. 09, 2006
					0.454	-1.09	Oct. 21, 2006
					0.437	-4.79	Dec. 12, 2006
					0.489	6.54	Dec. 19, 2006
					0.461	0.44	Dec. 26, 2006
SN:1037	2450	CW	100	0.479	0.501	4.59	Oct. 09, 2006
					0.511	6.68	Oct. 21, 2006

Table 3. Dipole H-Field Measurement Summary

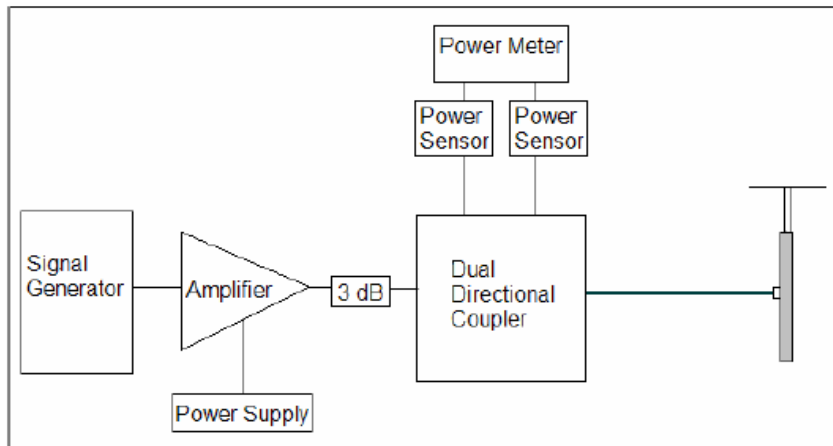

Figure 1. Setup for Validation



## **5. Probe Modulation Factor**

After every probe calibration, the response of the probe to each applicable modulated signal (CDMA, GSM, etc) must be assessed at both 835 MHz, 1880 MHz. The response of the probe system to a CW field at the frequency(s) of interest is compared to its response to a modulated signal with equal peak amplitude. For each PMF assessment, a Signal Generator was used to replace the original CW signal with the desired modulated signal. The PMF results are shown in Tables 4. RF Field Probe Modulation Response was measured with the field probe and associated measurement equipment. The PMF was measured per ANSI PC63.19-2006 using a signal generator as follows:

1. Illuminate a dipole with a CW signal at the intended measured frequency.
2. Fix the probe at a set location relative to the dipole; typically located at the field reference point.
3. Record the reading of the probe measurement system of the CW signal.
4. Substitute a modulated signal of the same amplitude, using the same modulation as that used by the intended WD for the CW signal.
5. Record the reading of the probe measurement system of the modulated signal.
6. The ratio of the CW to modulated signal reading is the probe modulation factor.



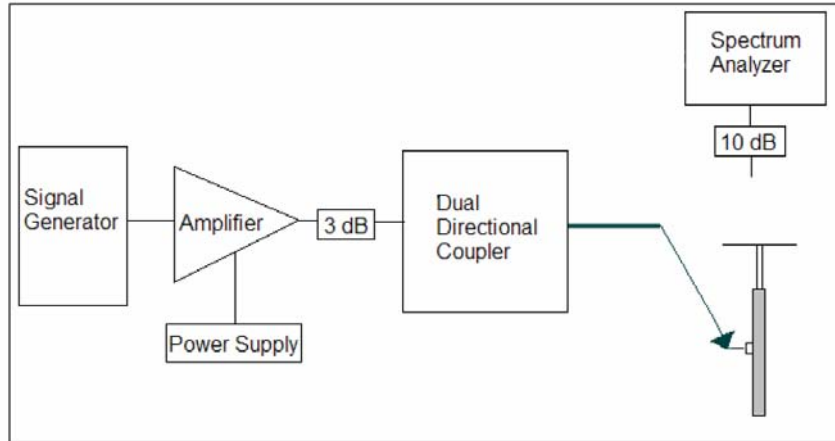

Figure 2. Setup to Dipole

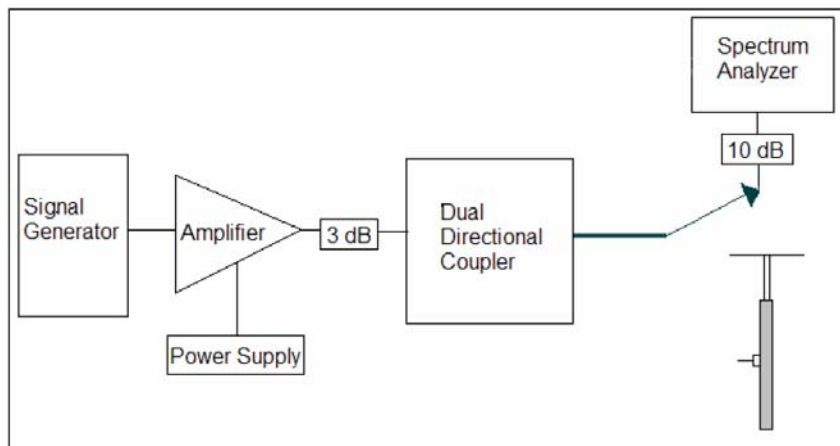

Figure 3. Setup for Desired Peak Power using Spectrum Analyzer



F (MHz)	Protocol	Peak Power (mW)	E-Field Probe SN:2256		H-Field Probe SN:6076	
			E-Field (V/m)	E-Field Modulation Factor	H-Field (A/m)	H-Field Modulation Factor
836.5	CW	100	168.6		1.180	
	80% AM	100	168.4	1.00	1.120	1.05
	CDMA	100	126.5	1.33	0.941	1.25
1880	CW	100	72.6		0.266	
	80% AM	100	64.8	1.12	0.234	1.14
	CDMA	100	68.2	1.06	0.246	1.08
2437	CW	100	216.4		0.809	
	80% AM	100	209.4	1.03	0.760	1.06
	802.11b	100	244.8	0.88	0.992	0.82
2437	CW	100	161.9		0.605	
	80% AM	100	157.0	1.03	0.563	1.07
	802.11g	100	250.1	0.65	1.000	0.61

**Table 4. PMF Measurement Summary**

Note: PMF measurements were verified at WD's power as an input to the dipole.



## 6. Uncertainty

Uncertainty Description	Uncertainty Value (+/- %)	Prob. Dist	Div.	(ci) E	(ci) H	Std. Unc. E	Std. Unc. H
<b>MEASUREMENT SYSTEM</b>							
Probe Calibration	5.1%	N	1.0000	1	1	5.1%	5.1%
Axial Isotropy	4.7%	R	1.7321	1	1	2.7%	2.7%
Sensor Displacement	16.5%	R	1.7321	1	0.145	9.5%	1.4%
Boundary Effects	2.4%	R	1.7321	1	1	1.4%	1.4%
Linearity	4.7%	R	1.7321	1	1	2.7%	2.7%
Scaling to Peak Envelope Power	2.0%	R	1.7321	1	1	1.2%	1.2%
System Detection Limit	1.0%	R	1.7321	1	1	0.6%	0.6%
Readout Electronics	0.3%	N	1.0000	1	1	0.3%	0.3%
Response Time	0.8%	R	1.7321	1	1	0.5%	0.5%
Integration Time	2.6%	R	1.7321	1	1	1.5%	1.5%
RF Reflections	7.2%	R	1.7321	1	1	4.2%	4.2%
Probe Positioner	1.2%	R	1.7321	1	0.67	0.7%	0.5%
Probe Positioning	4.7%	R	1.7321	1	0.67	2.7%	1.8%
Extrap. & Interpolation	1.0%	R	1.7321	1	1	0.6%	0.6%
<b>TEST SAMPLE RELATED</b>							
Total Device Positioning	3.2%	R	1.7321	1	1.306	1.8%	2.4%
Device Holder & Phantom	2.4%	R	1.7321	1	1	1.4%	1.4%
Power Drift	2.0%	R	1.7321	1	1	2.9%	2.9%
<b>PHANTOM AND SETUP RELATED</b>							
Phantom Thickness	2.4%	R	1.7321	1	0.67	1.4%	0.9%
<b>Combined Std.Uncertainty</b>						<b>13.4 %</b>	<b>9.4 %</b>
<b>Expanded Std. Uncertainty on Power</b>						<b>26.7 %</b>	<b>18.7 %</b>



## **7. Test Results**

The phone was tested in all normal configurations for the ear use. When applicable, each configuration is tested with the antenna in its fully extended and fully retracted positions. These test configurations are tested at the high, middle and low frequency channels of each applicable operating mode; for example, GSM, CDMA and TDMA.

The signal was setup by creating and maintaining an over the air connection between the DUT and an Agilent 8960 Wireless Communications Test Set. The CDMA radio is available on CDMA 2000(1X) and IS-95. The test equipment was configured to use "all up bits" for RC1 / SO2 on J-STD-008 for CDMA 1900 and TSB-84 for CDMA 800 MHz. The Wideband and Zero Span spectrum analyzer plots are shown in Appendix A.

The DASY4 v4.6 measurement system specified in section 3.1 was utilized within the intended operations as set by the SPEAG™ setup. The default settings for the grid spacing of the scan were set to 5mm as shown in the Field plots included in Appendix B and C. The 5cm x 5cm area measurement grid is centered on the acoustic output of the device. The Test Arch provided by SPEAG is used to position the DUT. The WD reference plane is parallel to the device and contains the highest point on its contour in the area of the phone that normally rests against the user's ear. The measurement plane contains the nearest point on the probe sensor(s) relative to the WD. The pictures of the setup are included in 7.3.

The device is positioned such that the WD reference plane is located 10mm from, and parallel to, the measurement plane. This is in accordance with section 4.3 of the standard, which states that "The WD reference plane is a plane parallel with the front "face" of the WD and containing the highest point on its contour in the area of the phone that normally rests against the user's ear."

The EUT photo with setup photo included in 06-0200-H\_EUT Picture.

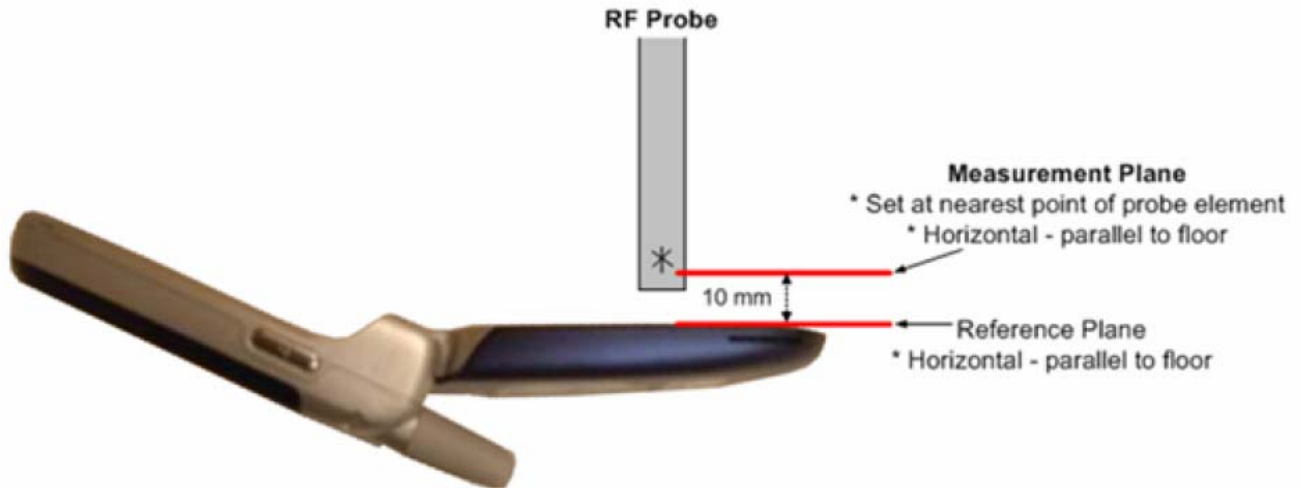

**Figure 4. Clarification of Figure A-2 from the Standard**

The HAC Rating results for E-Field and H-field are shown in 7.1 and 7.2. Also shown are the measured conducted output powers, the measured drifts, excluded areas, and the peak fields. PMF measurements are taken from Section 5. The worst-case test conditions are indicated with bold numbers in the tables and are detailed in Appendix C/D: HAC distribution plots for E-Field and H-Field.

Drift was measured using the typical DASY4 v4.7 measurement routines. The field is measured at the reference location (center of the ear piece) at the beginning of the test. Then after completion of the E or H field measurement, the probe returns to the same reference location and takes another measurement. The drift is the delta between these two values and is included in the test report scans.

The cellular phone model covered by this report has the following battery options:

Battery - TRIN160 is 1500 mAH



**7.1 HAC E-Field measurement results:**

Band	Rating	E-Field
CDMA 850	M3	199.5 to 354.8 V/m
	M4	< 199.5 V/m
CDMA 1900	M3	63.1 to 112.2 V/m
	M4	<63.1 V/m
802.11b(DSSS)	M3	63.1 to 112.2 V/m
802.11g(OFDM)	M4	<63.1 V/m

Table 5. Emissions Limits



7.1.1 TITA100 – Mode 1 measurement results:

Band	Channel	Conducted Power (dBm)	Measured PMF	Drift (dB)	Excluded Cells	Peak Field (V/m)	Rating
CDMA 850	1013	23.21	1.33	-0.025	6.8.9	150.8	M4
	384	23.25		0.058	6.8.9	169.5	M4
	777	23.01		-0.056	6.8.9	148.6	M4
CDMA 850 + 802.11b	1013	23.21	1.33	0.030	6.8.9	142.6	M4
	384	23.25		0.044	6.8.9	158.0	M4
	777	23.01		0.032	6.8.9	128.5	M4
CDMA 850 + 802.11g	1013	23.21	1.33	0.080	6.8.9	142.1	M4
	384	23.25		0.013	6.8.9	159.5	M4
	777	23.01		0.023	6.8.9	131.8	M4
CDMA 850 + Bluetooth	1013	23.21	1.33	-0.157	6.8.9	158.6	M4
	384	23.25		-0.071	6.8.9	171.3	M4
	777	23.01		-0.009	6.8.9	144.2	M4
CDMA 1900	25	23.51	1.06	-0.029	7.8.9	74.3	M3
	600	23.60		-0.128	7.8.9	82.0	M3
	1175	23.59		-0.134	7.8.9	86.3	M3
CDMA 1900 + 802.11b	25	23.51	1.06	0.055	7.8.9	63.3	M3
	600	23.60		-0.104	7.8.9	69.5	M3
	1175	23.59		-0.121	7.8.9	70.4	M3
CDMA 1900 + 802.11g	25	23.51	1.06	-0.073	7.8.9	62.2	M4
	600	23.60		-0.011	7.8.9	67.6	M3
	1175	23.59		-0.198	7.8.9	67.8	M3
CDMA 1900 + Bluetooth	1013	23.51	1.06	-0.056	7.8.9	63.4	M3
	384	23.60		0.009	7.8.9	70.0	M3
	777	23.59		-0.058	7.8.9	70.4	M3
802.11b DSSS	1	19.00	0.88	-0.150	1.2.3	19.3	M4
	6	19.05		-0.082	1.2.4	17.2	M4
	11	19.01		-0.169	1.2.3	16.7	M4
802.11g OFDM	1	19.03	0.65	-0.115	1.2.3	12.9	M4
	6	19.05		0.050	1.2.3	13.1	M4
	11	19.01		-0.175	1.2.3	12.8	M4

Note:

1. HAC E-Field measurement results for the portable cellular telephone at highest possible output power.
2. The LCD back-light "ON" to measurement the way. This is worst case for measurement.



7.1.2 TITA100 - Mode 2 measurement results:

Band	Channel	Conducted Power (dBm)	Measured PMF	Drift (dB)	Excluded Cells	Peak Field (V/m)	Rating
CDMA 850	1013	23.21	1.33	0.074	6.8.9	155.8	M4
	384	23.25		0.077	6.8.9	170.9	M4
	777	23.01		0.023	6.8.9	143.3	M4
CDMA 850 + 802.11b	1013	23.21	1.33	-0.046	6.8.9	148.4	M4
	384	23.25		0.131	6.8.9	168.3	M4
	777	23.01		-0.130	6.8.9	146.9	M4
CDMA 850 + 802.11g	1013	23.21	1.33	-0.022	6.8.9	150.9	M4
	384	23.25		-0.071	6.8.9	169.3	M4
	777	23.01		-0.021	6.8.9	144.7	M4
CDMA 850 + Bluetooth	1013	23.21	1.33	-0.117	6.8.9	147.5	M4
	384	23.25		0.007	6.8.9	170.3	M4
	777	23.01		0.035	6.8.9	148.3	M4
CDMA 1900	25	23.51	1.06	-0.025	7.8.9	65.9	M3
	600	23.60		0.071	7.8.9	70.9	M3
	1175	23.59		-0.024	7.8.9	74.8	M3
CDMA 1900 + 802.11b	25	23.51	1.06	0.162	7.8.9	67.5	M3
	600	23.60		0.134	7.8.9	75.6	M3
	1175	23.59		-0.031	7.8.9	78.0	M3
CDMA 1900 + 802.11g	25	23.51	1.06	0.021	7.8.9	76.4	M3
	600	23.60		-0.037	7.8.9	76.9	M3
	1175	23.59		-0.178	7.8.9	81.5	M3
CDMA 1900 + Bluetooth	1013	23.51	1.06	0.18	7.8.9	77.5	M3
	384	23.60		-0.034	7.8.9	77.2	M3
	777	23.59		0.012	7.8.9	79.3	M3
802.11b DSSS	1	19.00	0.88	-0.018	1.2.3	15.4	M4
	6	19.05		0.186	1.2.3	14.4	M4
	11	19.01		-0.157	1.2.3	14.9	M4
802.11g OFDM	1	19.03	0.65	-0.142	1.2.3	10.1	M4
	6	19.05		0.023	1.2.3	9.93	M4
	11	19.01		0.097	1.2.3	9.85	M4

Note:

1. HAC E-Field measurement results for the portable cellular telephone at highest possible output power.
2. The LCD back-light "ON" to measurement the way. This is worst case for measurement.





**7.2 HAC H-Field measurement results:**

Band	Rating	H-Field
CDMA 850	M3	0.6 to 1.07 A/m
	M4	< 0.60 A/m
CDMA 1900	M3	0.19 to 0.34 A/m
	M4	<0.19 A/m
802.11b(DSSS)	M3	0.19 to 0.34 A/m
802.11g(OFDM)	M4	<0.19 A/m

Table 6. Emissions Limits



7.2.1 TITA100 – Mode 1 measurement results:

Band	Channel	Conducted Power (dBm)	Measured PMF	Drift (dB)	Excluded Cells	Peak Field (A/m)	Rating
CDMA 850	1013	23.21	1.25	0.030	1.2.3	0.323	M4
	384	23.25		-0.081	1.2.3	0.366	M4
	777	23.01		0.016	1.2.3	0.323	M4
CDMA 850 + 802.11b	1013	23.21	1.25	0.027	1.2.3	0.328	M4
	384	23.25		-0.122	1.2.3	0.366	M4
	777	23.01		-0.091	1.2.3	0.306	M4
CDMA 850 + 802.11g	1013	23.21	1.25	-0.036	1.2.3	0.341	M4
	384	23.25		-0.006	1.2.3	0.381	M4
	777	23.01		-0.078	1.2.3	0.316	M4
CDMA 850 + Bluetooth	1013	23.21	1.25	-0.006	1.2.3	0.336	M4
	384	23.25		-0.053	1.2.3	0.372	M4
	777	23.01		0.087	1.2.3	0.307	M4
CDMA 1900	25	23.51	1.08	-0.031	1.2.4	0.266	M3
	600	23.60		-0.187	1.2.4	0.291	M3
	1175	23.59		-0.061	1.2.4	0.285	M3
CDMA 1900 + 802.11b	25	23.51	1.08	0.014	1.2.3	0.180	M4
	600	23.60		-0.007	1.2.3	0.192	M3
	1175	23.59		-0.094	1.2.3	0.182	M4
CDMA 1900 + 802.11g	25	23.51	1.08	-0.145	1.2.3	0.192	M3
	600	23.60		-0.110	1.2.3	0.207	M3
	1175	23.59		-0.129	1.2.3	0.197	M3
CDMA 1900 + Bluetooth	1013	23.51	1.08	-0.052	1.2.4	0.225	M3
	384	23.60		0.066	1.2.4	0.233	M3
	777	23.59		-0.153	1.2.4	0.224	M3
802.11b DSSS	1	19.00	0.82	-0.095	1.2.4	0.036	M4
	6	19.05		-0.110	1.2.4	0.036	M4
	11	19.01		-0.097	1.2.4	0.035	M4
802.11g OFDM	1	19.03	0.61	-0.154	1.2.4	0.028	M4
	6	19.05		-0.192	1.2.4	0.028	M4
	11	19.01		-0.040	1.2.4	0.026	M4

Note:

1. HAC E-Field measurement results for the portable cellular telephone at highest possible output power.
2. The LCD back-light "ON" to measurement the way. This is worst case for measurement.



7.2.2 TITA100 – Mode 2 measurement results:

Band	Channel	Conducted Power (dBm)	Measured PMF	Drift (dB)	Excluded Cells	Peak Field (A/m)	Rating
CDMA 850	1013	23.21	1.25	0.021	1.2.3	0.317	M4
	384	23.25		-0.006	1.2.3	0.365	M4
	777	23.01		-0.005	1.2.3	0.295	M4
CDMA 850 + 802.11b	1013	23.21	1.25	-0.127	1.2.3	0.374	M4
	384	23.25		-0.053	1.2.3	0.409	M4
	777	23.01		0.081	1.2.3	0.368	M4
CDMA 850 + 802.11g	1013	23.21	1.25	-0.005	1.2.3	0.343	M4
	384	23.25		-0.063	1.2.3	0.394	M4
	777	23.01		0.075	1.2.3	0.349	M4
CDMA 850 + Bluetooth	1013	23.21	1.25	0.034	1.2.3	0.326	M4
	384	23.25		-0.017	1.2.3	0.372	M4
	777	23.01		-0.020	1.2.3	0.325	M4
CDMA 1900	25	23.51	1.08	-0.072	1.2.4	0.223	M3
	600	23.60		0.056	1.2.4	0.235	M3
	1175	23.59		-0.081	1.2.4	0.237	M3
CDMA 1900 + 802.11b	25	23.51	1.08	-0.068	1.2.3	0.212	M3
	600	23.60		-0.074	1.2.4	0.279	M3
	1175	23.59		-0.156	1.2.4	0.278	M3
CDMA 1900 + 802.11g	25	23.51	1.08	-0.098	1.2.4	0.253	M3
	600	23.60		-0.122	1.2.4	0.279	M3
	1175	23.59		-0.043	1.2.4	0.269	M3
CDMA 1900 + Bluetooth	1013	23.51	1.08	-0.096	1.2.3	0.229	M3
	384	23.60		0.012	1.2.4	0.252	M3
	777	23.59		-0.060	1.2.4	0.249	M3
802.11b DSSS	1	19.00	0.82	-0.070	1.2.4	0.025	M4
	6	19.05		-0.027	1.2.4	0.026	M4
	11	19.01		-0.065	1.2.3	0.027	M4
802.11g OFDM	1	19.03	0.61	0.198	1.2.4	0.018	M4
	6	19.05		-0.142	1.2.4	0.019	M4
	11	19.01		-0.071	1.2.3	0.019	M4

Note:

1. HAC E-Field measurement results for the portable cellular telephone at highest possible output power.
2. The LCD back-light "ON" to measurement the way. This is worst case for measurement.



## Appendix A - Details of WD signal

836.5 MHz

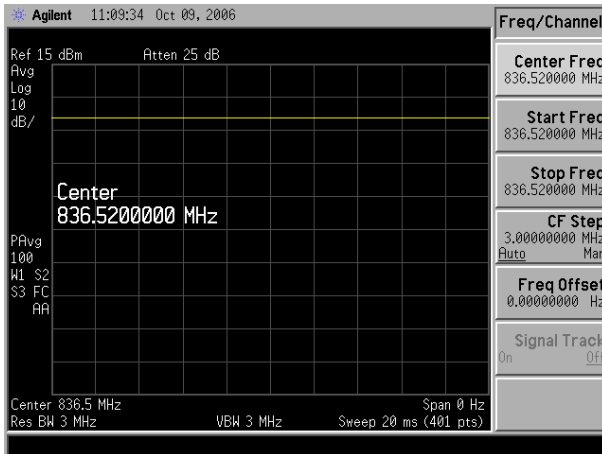

CW Signal

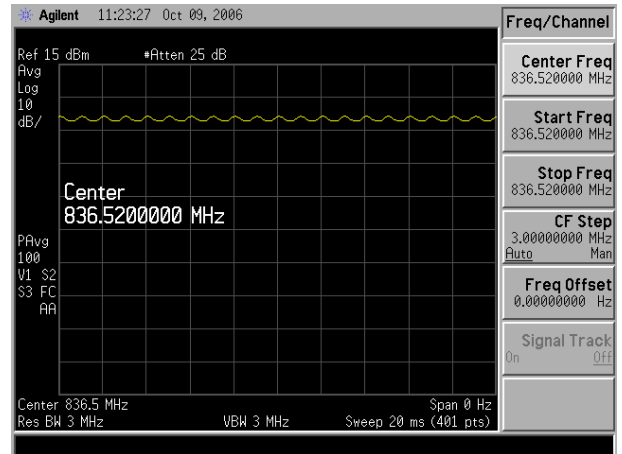

80% AM Signal

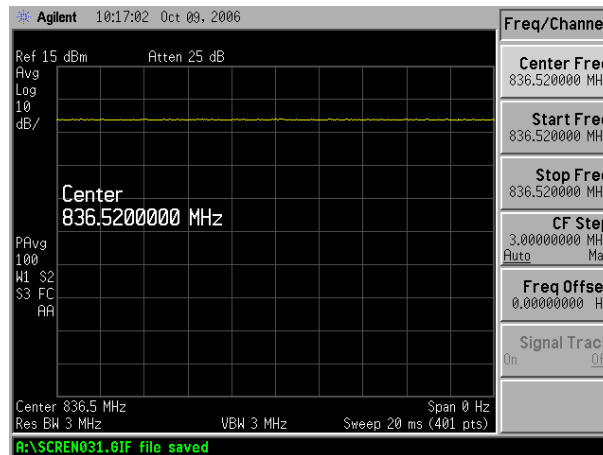

CDMA Signal



1880 MHz

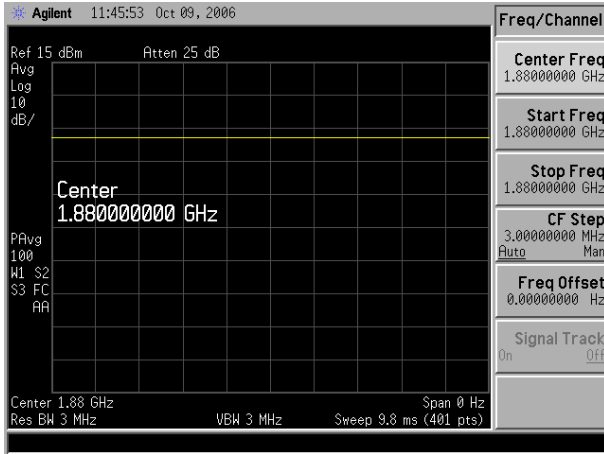

CW Signal

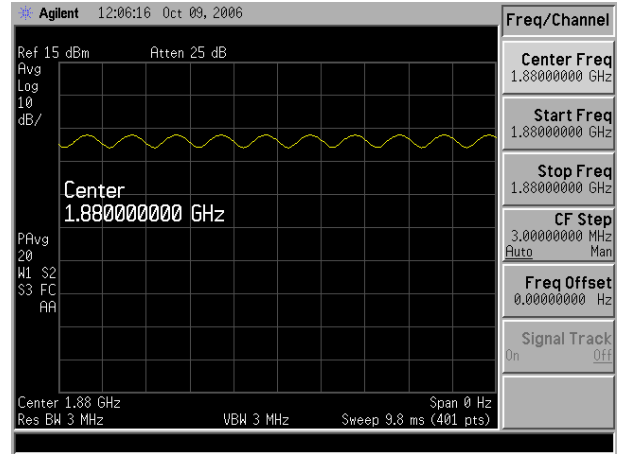

80% AM Signal



CDMA Signal



802.11b 2437 MHz

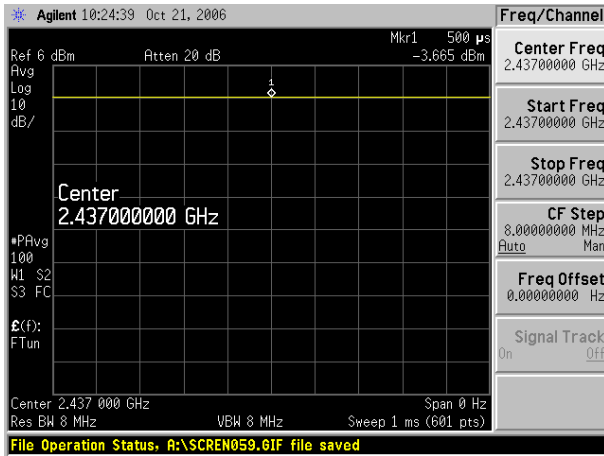

CW Signal

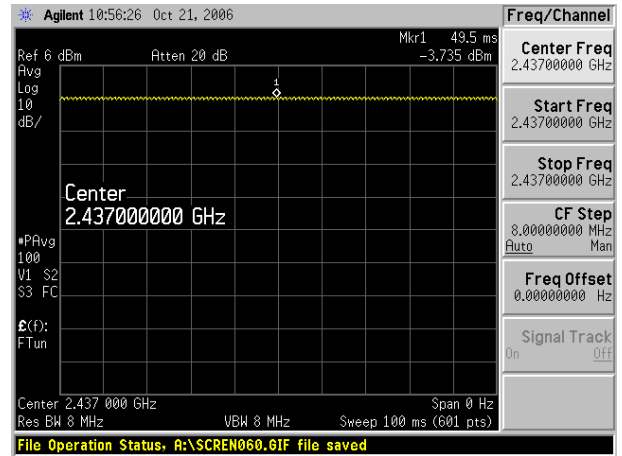

80% AM Signal

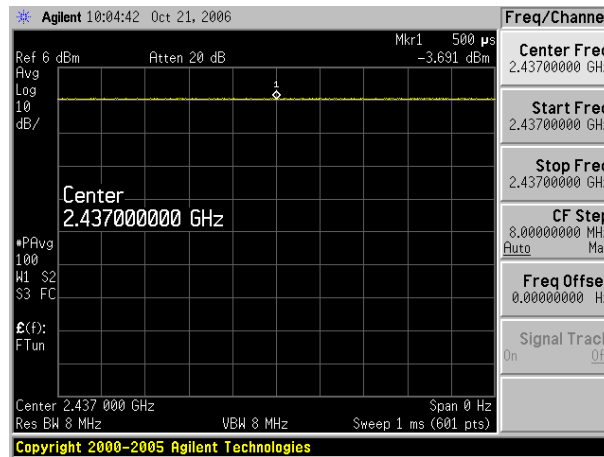

802.11b Signal



802.11g 2437 MHz

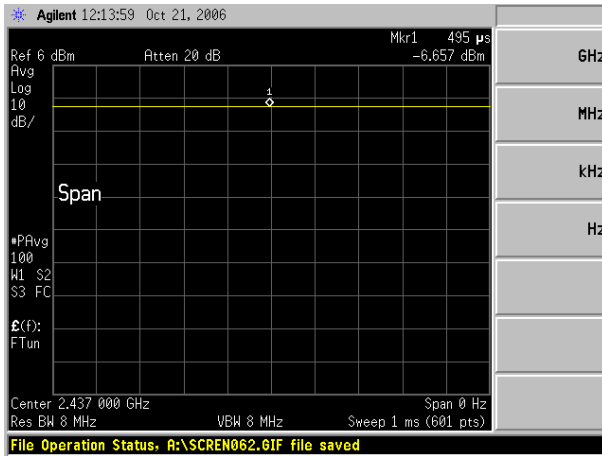

CW Signal

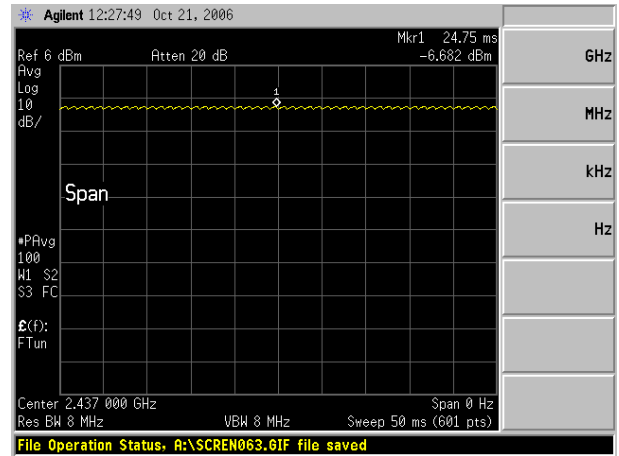

80% AM Signal

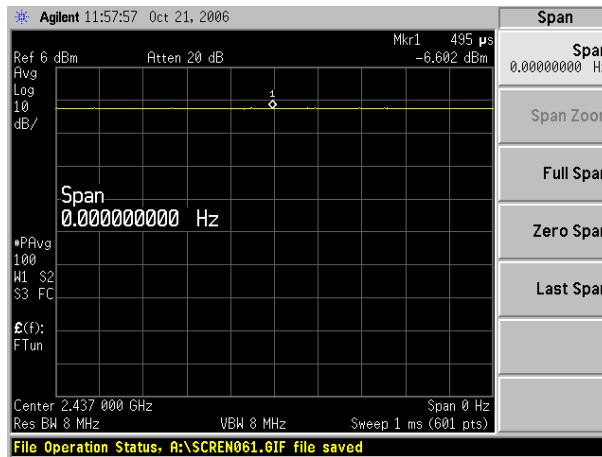

802.11g Signal



## ***Appendix B - Validation***

See following Attached Pages for Validation.





Test Laboratory: A Test Lab Techno Corp.

Date/Time: 10/09/2006 3:40:13 PM

**System Performance Check at 835MHz\_20061009\_E**

**DUT: Dipole 835 MHz; Type: CD835V3; Serial: CD835V3 - SN:1017**

Communication System: CW; Frequency: 835 MHz; Duty Cycle: 1:1

Medium parameters used:  $\sigma = 0$  mho/m,  $\epsilon_r = 1$ ;  $\rho = 1000$  kg/m<sup>3</sup>

Phantom section: E Dipole Section

Measurement Standard: DASYS4 (High Precision Assessment)

DASY4 Configuration:

- Probe: ER3DV6 - SN2256; ConvF(1, 1, 1); Calibrated: 10/21/2005
- Sensor-Surface: (Fix Surface)
- Electronics: DAE3 Sn393; Calibrated: 9/5/2006
- Phantom: HAC Test Arch; Type: SD HAC P01 BA; Serial:
- Measurement SW: DASYS4, V4.7 Build 44; Postprocessing SW: SEMCAD, V1.8 Build 171

**E Scan - ER3DV6 probe tip 10mm above Device Reference/Hearing Aid Compatibility Test (41x361x1):**

Measurement grid: dx=5mm, dy=5mm

Maximum value of peak Total field = 169.6 V/m

Probe Modulation Factor = 1.00

Reference Value = 111.1 V/m; Power Drift = -0.076 dB

**Hearing Aid Near-Field Category: M2 (AWF 0 dB)**

Peak E-field in V/m

Grid 1	Grid 2	Grid 3
<b>142.0</b>	<b>151.3</b>	<b>150.3</b>
Grid 4	Grid 5	Grid 6
<b>83.1</b>	<b>87.5</b>	<b>86.4</b>
Grid 7	Grid 8	Grid 9
<b>158.3</b>	<b>169.6</b>	<b>167.3</b>

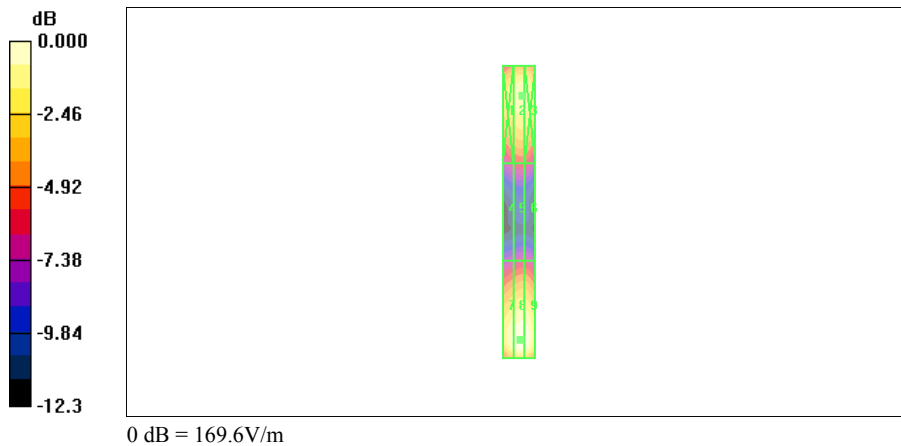



Test Laboratory: A Test Lab Techno Corp.

Date/Time: 10/21/2006 9:38:33 AM

**System Performance Check at 835MHz\_20061021\_E**

**DUT: Dipole 835 MHz; Type: CD835V3; Serial: CD835V3 - SN:1017**

Communication System: CW; Frequency: 835 MHz; Duty Cycle: 1:1

Medium parameters used:  $\sigma = 0$  mho/m,  $\epsilon_r = 1$ ;  $\rho = 1000$  kg/m<sup>3</sup>

Phantom section: E Dipole Section

Measurement Standard: DASYS4 (High Precision Assessment)

DASY4 Configuration:

- Probe: ER3DV6 - SN2256; ConvF(1, 1, 1); Calibrated: 10/21/2005
- Sensor-Surface: (Fix Surface)
- Electronics: DAE3 Sn393; Calibrated: 9/5/2006
- Phantom: HAC Test Arch; Type: SD HAC P01 BA; Serial:
- Measurement SW: DASYS4, V4.7 Build 44; Postprocessing SW: SEMCAD, V1.8 Build 171

**E Scan - ER3DV6 probe tip 10mm above Device Reference/Hearing Aid Compatibility Test (41x361x1):**

Measurement grid: dx=5mm, dy=5mm

Maximum value of peak Total field = 158.7 V/m

Probe Modulation Factor = 1.00

Reference Value = 100.3 V/m; Power Drift = -0.049 dB

**Hearing Aid Near-Field Category: M2 (AWF 0 dB)**

Peak E-field in V/m

Grid 1	Grid 2	Grid 3
<b>147.7</b>	<b>158.7</b>	<b>157.4</b>
Grid 4	Grid 5	Grid 6
<b>85.5</b>	<b>90.6</b>	<b>89.5</b>
Grid 7	Grid 8	Grid 9
<b>142.2</b>	<b>153.8</b>	<b>153.4</b>

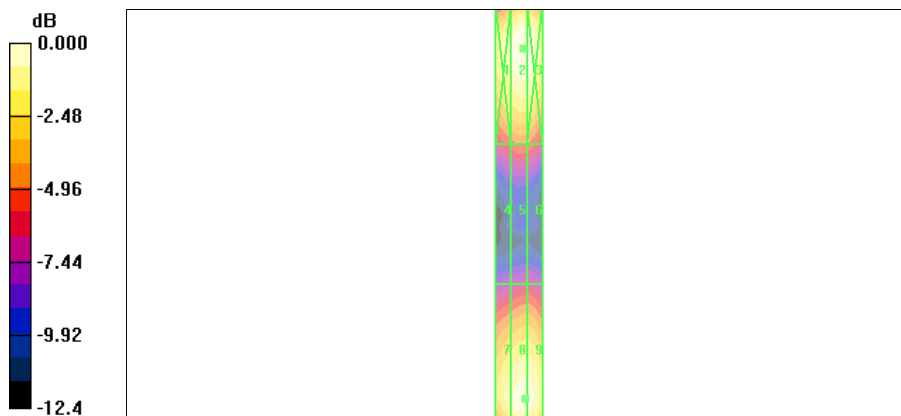



Test Laboratory: A Test Lab Techno Corp.

Date/Time: 12/12/2006 11:37:57 PM

**System Performance Check at 835MHz\_20061212\_E**

**DUT: Dipole 835 MHz; Type: CD835V3; Serial: CD835V3 - SN:1017**

Communication System: CW; Frequency: 835 MHz; Duty Cycle: 1:1

Medium parameters used:  $\sigma = 0$  mho/m,  $\epsilon_r = 1$ ;  $\rho = 1000$  kg/m<sup>3</sup>

Phantom section: E Dipole Section

Measurement Standard: DAS4 (High Precision Assessment)

DASY4 Configuration:

- Probe: ER3DV6 - SN2256; ConvF(1, 1, 1); Calibrated: 10/21/2005
- Sensor-Surface: (Fix Surface)
- Electronics: DAE3 Sn393; Calibrated: 9/5/2006
- Phantom: HAC Test Arch; Type: SD HAC P01 BA; Serial:
- Measurement SW: DAS4, V4.7 Build 44; Postprocessing SW: SEMCAD, V1.8 Build 171

**E Scan - ER3DV6 probe tip 10mm above Device Reference/Hearing Aid Compatibility Test (41x361x1):**

Measurement grid: dx=5mm, dy=5mm

Maximum value of peak Total field = 170.1 V/m

Probe Modulation Factor = 1.00

Reference Value = 108.2 V/m; Power Drift = -0.020 dB

**Hearing Aid Near-Field Category: M2 (AWF 0 dB)**

Peak E-field in V/m

Grid 1	Grid 2	Grid 3
<b>138.0</b>	<b>151.6</b>	<b>151.5</b>
Grid 4	Grid 5	Grid 6
<b>76.4</b>	<b>82.4</b>	<b>82.1</b>
Grid 7	Grid 8	Grid 9
<b>159.4</b>	<b>170.1</b>	<b>164.7</b>

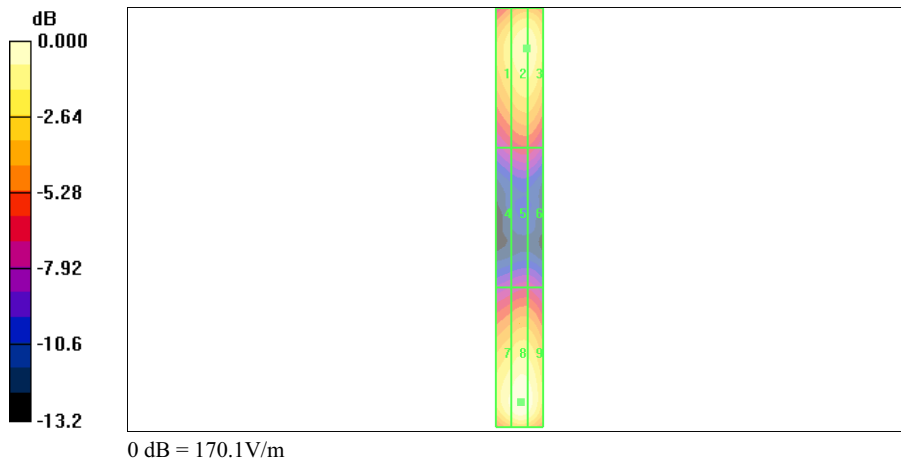



Test Laboratory: A Test Lab Techno Corp.

Date/Time: 12/19/2006 7:13:05 AM

**System Performance Check at 835MHz\_20061219\_E**

**DUT: Dipole 835 MHz; Type: CD835V3; Serial: CD835V3 - SN:1017**

Communication System: CW; Frequency: 835 MHz; Duty Cycle: 1:1

Medium parameters used:  $\sigma = 0$  mho/m,  $\epsilon_r = 1$ ;  $\rho = 1000$  kg/m<sup>3</sup>

Phantom section: E Dipole Section

Measurement Standard: DAS4 (High Precision Assessment)

DASY4 Configuration:

- Probe: ER3DV6 - SN2256; ConvF(1, 1, 1); Calibrated: 10/21/2005
- Sensor-Surface: (Fix Surface)
- Electronics: DAE3 Sn393; Calibrated: 9/5/2006
- Phantom: HAC Test Arch; Type: SD HAC P01 BA; Serial:
- Measurement SW: DAS4, V4.7 Build 44; Postprocessing SW: SEMCAD, V1.8 Build 171

**E Scan - ER3DV6 probe tip 10mm above Device Reference/Hearing Aid Compatibility Test (41x361x1):**

Measurement grid: dx=5mm, dy=5mm

Maximum value of peak Total field = 178.3 V/m

Probe Modulation Factor = 1.00

Reference Value = 114.1 V/m; Power Drift = -0.028 dB

**Hearing Aid Near-Field Category: M2 (AWF 0 dB)**

Peak E-field in V/m

Grid 1	Grid 2	Grid 3
<b>151.0</b>	<b>164.8</b>	<b>164.5</b>
Grid 4	Grid 5	Grid 6
<b>88.4</b>	<b>95.0</b>	<b>94.5</b>
Grid 7	Grid 8	Grid 9
<b>168.4</b>	<b>178.3</b>	<b>171.9</b>

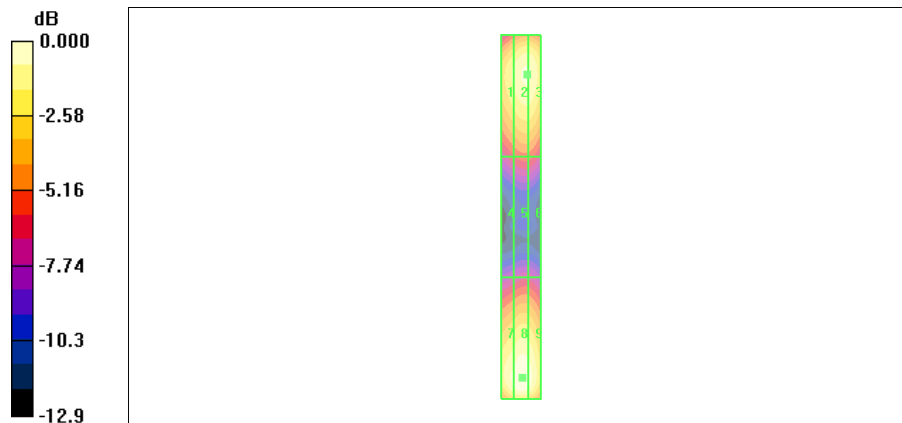

0 dB = 178.3V/m



Test Laboratory: A Test Lab Techno Corp.

Date/Time: 12/26/2006 8:27:21 PM

**System Performance Check at 835MHz\_20061226\_E**

**DUT: Dipole 835 MHz; Type: CD835V3; Serial: CD835V3 - SN:1017**

Communication System: CW; Frequency: 835 MHz; Duty Cycle: 1:1

Medium parameters used:  $\sigma = 0$  mho/m,  $\epsilon_r = 1$ ;  $\rho = 1000$  kg/m<sup>3</sup>

Phantom section: E Dipole Section

Measurement Standard: DAS4 (High Precision Assessment)

DASY4 Configuration:

- Probe: ER3DV6 - SN2256; ConvF(1, 1, 1); Calibrated: 10/21/2005
- Sensor-Surface: (Fix Surface)
- Electronics: DAE4 Sn541; Calibrated: 10/16/2006
- Phantom: HAC Test Arch; Type: SD HAC P01 BA; Serial:
- Measurement SW: DASY4, V4.7 Build 44; Postprocessing SW: SEMCAD, V1.8 Build 171

**E Scan - ER3DV6 probe tip 10mm above Device Reference/Hearing Aid Compatibility Test (41x361x1):**

Measurement grid: dx=5mm, dy=5mm

Maximum value of peak Total field = 182.1 V/m

Probe Modulation Factor = 1.00

Reference Value = 112.6 V/m; Power Drift = -0.020 dB

**Hearing Aid Near-Field Category: M2 (AWF 0 dB)**

Peak E-field in V/m

Grid 1	Grid 2	Grid 3
<b>134.7</b>	<b>144.8</b>	<b>143.6</b>
Grid 4	Grid 5	Grid 6
<b>76.1</b>	<b>81.9</b>	<b>81.4</b>
Grid 7	Grid 8	Grid 9
<b>159.6</b>	<b>182.1</b>	<b>182.0</b>

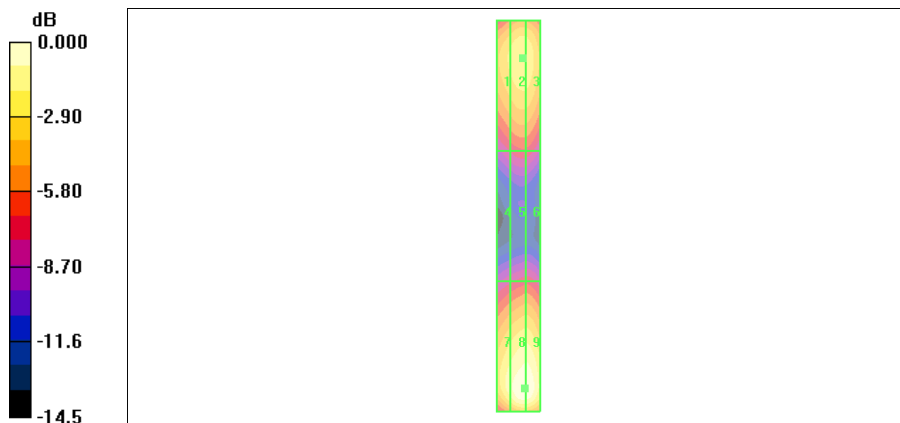

0 dB = 182.1V/m



Test Laboratory: A Test Lab Techno Corp.

Date/Time: 10/09/2006 2:04:03 PM

**System Performance Check at 1880MHz\_20061009\_E**

**DUT: Dipole 1880 MHz; Type: CD1880V3; Serial: CD1880V3 - SN:1036**

Communication System: CW; Frequency: 1880 MHz; Duty Cycle: 1:1

Medium parameters used:  $\sigma = 0$  mho/m,  $\epsilon_r = 1$ ;  $\rho = 1000$  kg/m<sup>3</sup>

Phantom section: E Dipole Section

Measurement Standard: DASYS4 (High Precision Assessment)

DASY4 Configuration:

- Probe: ER3DV6 - SN2256; ConvF(1, 1, 1); Calibrated: 10/21/2005
- Sensor-Surface: (Fix Surface)
- Electronics: DAE3 Sn393; Calibrated: 9/5/2006
- Phantom: HAC Test Arch; Type: SD HAC P01 BA; Serial:
- Measurement SW: DASYS4, V4.7 Build 44; Postprocessing SW: SEMCAD, V1.8 Build 171

**E Scan - ER3DV6 probe tip 10mm above Device Reference/Hearing Aid Compatibility Test (41x181x1):**

Measurement grid: dx=5mm, dy=5mm

Maximum value of peak Total field = 151.4 V/m

Probe Modulation Factor = 1.00

Reference Value = 75.6 V/m; Power Drift = 0.003 dB

**Hearing Aid Near-Field Category: M2 (AWF 0 dB)**

Peak E-field in V/m

Grid 1	Grid 2	Grid 3
<b>136.2</b>	<b>148.2</b>	<b>146.7</b>
Grid 4	Grid 5	Grid 6
<b>93.4</b>	<b>98.6</b>	<b>96.5</b>
Grid 7	Grid 8	Grid 9
<b>140.1</b>	<b>151.4</b>	<b>148.7</b>

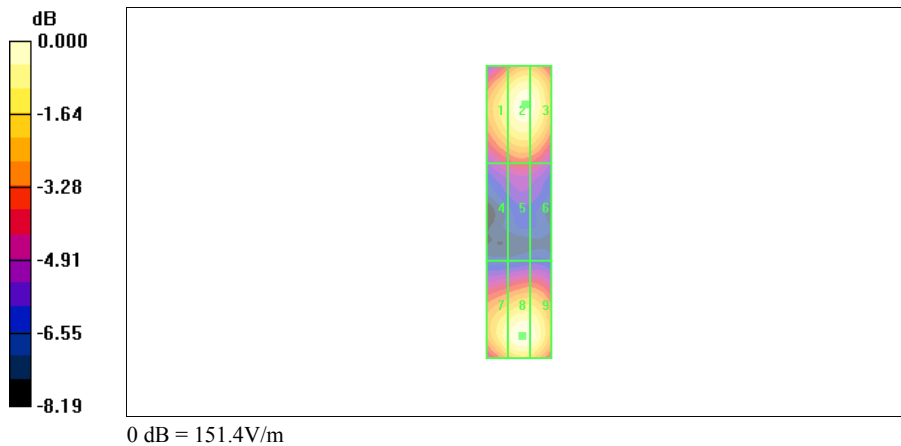



Test Laboratory: A Test Lab Techno Corp.

Date/Time: 10/21/2006 10:10:16 AM

**System Performance Check at 1880MHz\_20061021\_E**

**DUT: Dipole 1880 MHz; Type: CD1880V3; Serial: CD1880V3 - SN:1036**

Communication System: CW; Frequency: 1880 MHz; Duty Cycle: 1:1

Medium parameters used:  $\sigma = 0$  mho/m,  $\epsilon_r = 1$ ;  $\rho = 1000$  kg/m<sup>3</sup>

Phantom section: E Dipole Section

Measurement Standard: DASYS4 (High Precision Assessment)

DASY4 Configuration:

- Probe: ER3DV6 - SN2256; ConvF(1, 1, 1); Calibrated: 10/21/2005
- Sensor-Surface: (Fix Surface)
- Electronics: DAE3 Sn393; Calibrated: 9/5/2006
- Phantom: HAC Test Arch; Type: SD HAC P01 BA; Serial:
- Measurement SW: DASYS4, V4.7 Build 44; Postprocessing SW: SEMCAD, V1.8 Build 171

**E Scan - ER3DV6 probe tip 10mm above Device Reference/Hearing Aid Compatibility Test (41x181x1):**

Measurement grid: dx=5mm, dy=5mm

Maximum value of peak Total field = 149.3 V/m

Probe Modulation Factor = 1.00

Reference Value = 148.5 V/m; Power Drift = -0.017 dB

**Hearing Aid Near-Field Category: M2 (AWF 0 dB)**

Peak E-field in V/m

Grid 1	Grid 2	Grid 3
<b>139.4</b>	<b>149.3</b>	<b>147.1</b>
Grid 4	Grid 5	Grid 6
<b>99.4</b>	<b>104.2</b>	<b>101.8</b>
Grid 7	Grid 8	Grid 9
<b>122.7</b>	<b>133.4</b>	<b>132.9</b>

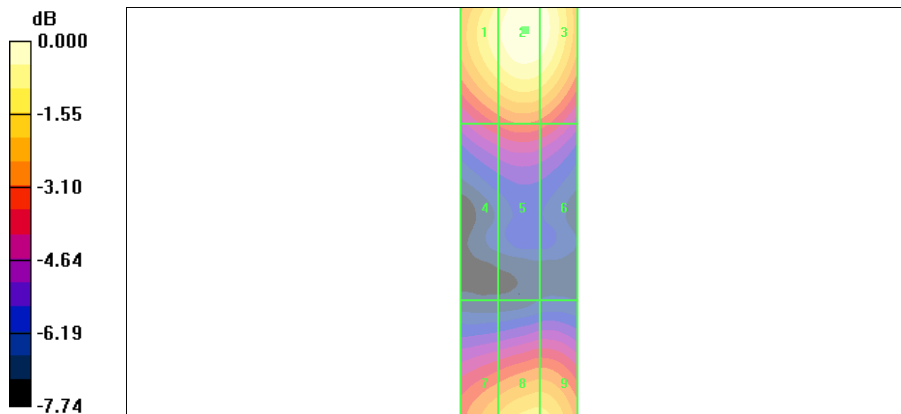

0 dB = 149.3V/m



Test Laboratory: A Test Lab Techno Corp.

Date/Time: 12/13/2006 12:28:35 AM

**System Performance Check at 1880MHz\_20061212\_E**

**DUT: Dipole 1880 MHz; Type: CD1880V3; Serial: CD1880V3 - SN:1036**

Communication System: CW; Frequency: 1880 MHz; Duty Cycle: 1:1

Medium parameters used:  $\sigma = 0$  mho/m,  $\epsilon_r = 1$ ;  $\rho = 1000$  kg/m<sup>3</sup>

Phantom section: E Dipole Section

Measurement Standard: DASYS4 (High Precision Assessment)

DASY4 Configuration:

- Probe: ER3DV6 - SN2256; ConvF(1, 1, 1); Calibrated: 10/21/2005
- Sensor-Surface: (Fix Surface)
- Electronics: DAE3 Sn393; Calibrated: 9/5/2006
- Phantom: HAC Test Arch; Type: SD HAC P01 BA; Serial:
- Measurement SW: DASYS4, V4.7 Build 44; Postprocessing SW: SEMCAD, V1.8 Build 171

**E Scan - ER3DV6 probe tip 10mm above Device Reference/Hearing Aid Compatibility Test (41x181x1):**

Measurement grid: dx=5mm, dy=5mm

Maximum value of peak Total field = 139.6 V/m

Probe Modulation Factor = 1.00

Reference Value = 142.7 V/m; Power Drift = -0.011 dB

**Hearing Aid Near-Field Category: M2 (AWF 0 dB)**

Peak E-field in V/m

Grid 1	Grid 2	Grid 3
<b>127.9</b>	<b>139.6</b>	<b>138.6</b>
Grid 4	Grid 5	Grid 6
<b>84.7</b>	<b>89.6</b>	<b>88.1</b>
Grid 7	Grid 8	Grid 9
<b>120.1</b>	<b>129.4</b>	<b>127.3</b>

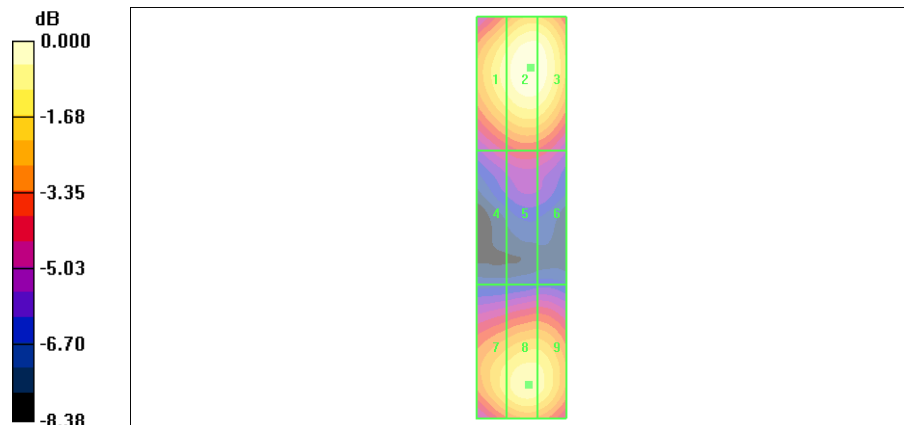

0 dB = 139.6V/m





Test Laboratory: A Test Lab Techno Corp.

Date/Time: 12/19/2006 7:43:20 AM

**System Performance Check at 1880MHz\_20061219\_E**

**DUT: Dipole 1880 MHz; Type: CD1880V3; Serial: CD1880V3 - SN:1036**

Communication System: CW; Frequency: 1880 MHz; Duty Cycle: 1:1

Medium parameters used:  $\sigma = 0$  mho/m,  $\epsilon_r = 1$ ;  $\rho = 1000$  kg/m<sup>3</sup>

Phantom section: E Dipole Section

Measurement Standard: DASYS4 (High Precision Assessment)

DASY4 Configuration:

- Probe: ER3DV6 - SN2256; ConvF(1, 1, 1); Calibrated: 10/21/2005
- Sensor-Surface: (Fix Surface)
- Electronics: DAE3 Sn393; Calibrated: 9/5/2006
- Phantom: HAC Test Arch; Type: SD HAC P01 BA; Serial:
- Measurement SW: DASYS4, V4.7 Build 44; Postprocessing SW: SEMCAD, V1.8 Build 171

**E Scan - ER3DV6 probe tip 10mm above Device Reference/Hearing Aid Compatibility Test (41x181x1):**

Measurement grid: dx=5mm, dy=5mm

Maximum value of peak Total field = 154.2 V/m

Probe Modulation Factor = 1.00

Reference Value = 171.0 V/m; Power Drift = -0.017 dB

**Hearing Aid Near-Field Category: M2 (AWF 0 dB)**

Peak E-field in V/m

Grid 1	Grid 2	Grid 3
<b>141.3</b>	<b>154.2</b>	<b>152.9</b>
Grid 4	Grid 5	Grid 6
<b>95.2</b>	<b>100.9</b>	<b>99.2</b>
Grid 7	Grid 8	Grid 9
<b>140.9</b>	<b>151.7</b>	<b>148.3</b>

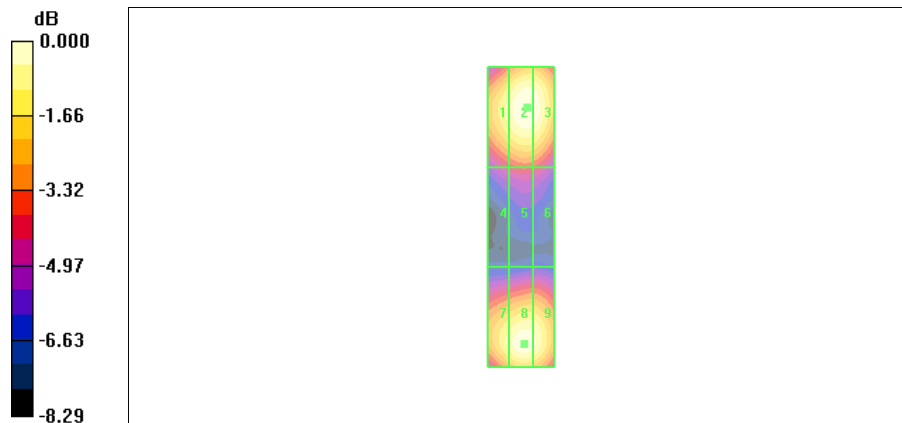

0 dB = 154.2V/m



Test Laboratory: A Test Lab Techno Corp.

Date/Time: 12/26/2006 6:33:28 PM

**System Performance Check at 1880MHz\_20061226\_E**

**DUT: Dipole 1880 MHz; Type: CD1880V3; Serial: CD1880V3 - SN:1036**

Communication System: CW; Frequency: 1880 MHz; Duty Cycle: 1:1

Medium parameters used:  $\sigma = 0$  mho/m,  $\epsilon_r = 1$ ;  $\rho = 1000$  kg/m<sup>3</sup>

Phantom section: E Dipole Section

Measurement Standard: DASYS4 (High Precision Assessment)

DASY4 Configuration:

- Probe: ER3DV6 - SN2256; ConvF(1, 1, 1); Calibrated: 10/21/2005
- Sensor-Surface: (Fix Surface)
- Electronics: DAE4 Sn541; Calibrated: 10/16/2006
- Phantom: HAC Test Arch; Type: SD HAC P01 BA; Serial:
- Measurement SW: DASYS4, V4.7 Build 44; Postprocessing SW: SEMCAD, V1.8 Build 171

**E Scan - ER3DV6 probe tip 10mm above Device Reference/Hearing Aid Compatibility Test (41x181x1):**

Measurement grid: dx=5mm, dy=5mm

Maximum value of peak Total field = 146.2 V/m

Probe Modulation Factor = 1.00

Reference Value = 162.0 V/m; Power Drift = 0.014 dB

**Hearing Aid Near-Field Category: M2 (AWF 0 dB)**

Peak E-field in V/m

Grid 1	Grid 2	Grid 3
<b>133.2</b>	<b>146.2</b>	<b>145.0</b>
Grid 4	Grid 5	Grid 6
<b>91.1</b>	<b>97.3</b>	<b>95.8</b>
Grid 7	Grid 8	Grid 9
<b>132.1</b>	<b>143.7</b>	<b>142.3</b>

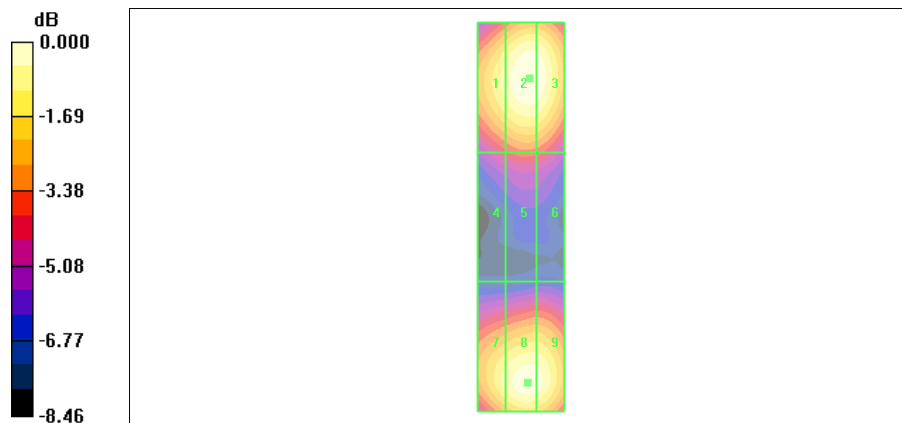

0 dB = 146.2V/m



Test Laboratory: A Test Lab Techno Corp.

Date/Time: 10/9/2006 7:07:14 PM

**System Performance Check at 2450MHz\_20061009\_E**

**DUT: Dipole 2450 MHz; Type: CD2450V3; Serial: CD2450V3 - SN:1037**

Communication System: CW; Frequency: 2450 MHz; Duty Cycle: 1:1

Medium parameters used:  $\sigma = 0$  mho/m,  $\epsilon_r = 1$ ;  $\rho = 1000$  kg/m<sup>3</sup>

Phantom section: E Dipole Section

Measurement Standard: DASYS4 (High Precision Assessment)

DASY4 Configuration:

- Probe: ER3DV6 - SN2256; ConvF(1, 1, 1); Calibrated: 10/21/2005
- Sensor-Surface: (Fix Surface)
- Electronics: DAE3 Sn393; Calibrated: 9/5/2006
- Phantom: HAC Test Arch; Type: SD HAC P01 BA; Serial:
- Measurement SW: DASYS4, V4.7 Build 44; Postprocessing SW: SEMCAD, V1.8 Build 171

**E Scan - ER3DV6 probe tip 10mm above Device Reference/Hearing Aid Compatibility Test (41x181x1):**

Measurement grid: dx=5mm,dy=5mm

Maximum value of peak Total field = 144.2 V/m

Probe Modulation Factor = 1.00

Reference Value = 85.9 V/m; Power Drift = -0.099 dB

**Hearing Aid Near-Field Category: M2 (AWF 0 dB)**

Peak E-field in V/m

Grid 1	Grid 2	Grid 3
<b>133.8</b>	<b>144.2</b>	<b>141.8</b>
Grid 4	Grid 5	Grid 6
<b>117.4</b>	<b>124.1</b>	<b>121.0</b>
Grid 7	Grid 8	Grid 9
<b>128.3</b>	<b>139.2</b>	<b>137.7</b>

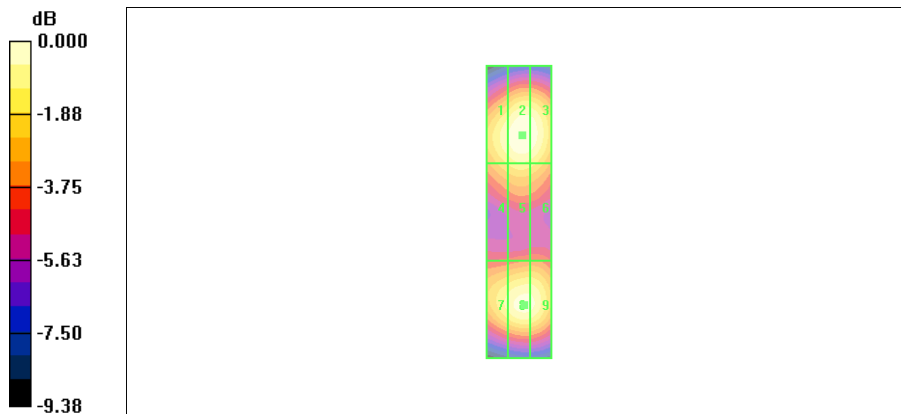

0 dB = 144.2V/m



Test Laboratory: A Test Lab Techno Corp.

Date/Time: 10/21/2006 11:08:42 AM

**System Performance Check at 2450MHz\_20061021\_E**

**DUT: Dipole 2450 MHz; Type: CD2450V2; Serial: CD2450V3 - SN:1037**

Communication System: CW; Frequency: 2450 MHz; Duty Cycle: 1:1

Medium parameters used:  $\sigma = 0$  mho/m,  $\epsilon_r = 1$ ;  $\rho = 1000$  kg/m<sup>3</sup>

Phantom section: E Dipole Section

Measurement Standard: DASYS4 (High Precision Assessment)

DASY4 Configuration:

- Probe: ER3DV6 - SN2256; ConvF(1, 1, 1); Calibrated: 10/21/2005
- Sensor-Surface: (Fix Surface)
- Electronics: DAE3 Sn393; Calibrated: 9/5/2006
- Phantom: HAC Test Arch; Type: SD HAC P01 BA; Serial:
- Measurement SW: DASYS4, V4.7 Build 44; Postprocessing SW: SEMCAD, V1.8 Build 171

**E Scan - ER3DV6 probe tip 10mm above Device Reference/Hearing Aid Compatibility Test (41x181x1):**

Measurement grid: dx=5mm, dy=5mm

Maximum value of peak Total field = 147.5 V/m

Probe Modulation Factor = 1.00

Reference Value = 88.4 V/m; Power Drift = -0.065 dB

**Hearing Aid Near-Field Category: M2 (AWF 0 dB)**

Peak E-field in V/m

Grid 1	Grid 2	Grid 3
137.4	147.5	144.7
Grid 4	Grid 5	Grid 6
121.2	128.1	124.3
Grid 7	Grid 8	Grid 9
125.0	137.3	136.9

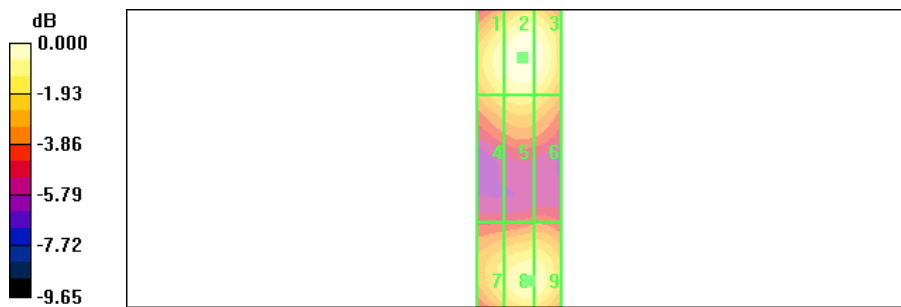

0 dB = 147.5V/m



Test Laboratory: A Test Lab Techno Corp.

Date/Time: 10/09/2006 4:58:31 PM

**System Performance Check at 835MHz\_20061009\_H**

**DUT: Dipole 835 MHz; Type: CD835V3; Serial: CD835V3 - SN:1017**

Communication System: CW; Frequency: 835 MHz; Duty Cycle: 1:1

Medium parameters used:  $\sigma = 0$  mho/m,  $\epsilon_r = 1$ ;  $\rho = 1$  kg/m<sup>3</sup>

Phantom section: H Dipole Section

Measurement Standard: DAS4 (High Precision Assessment)

DASY4 Configuration:

- Probe: H3DV6 - SN6076; ; Calibrated: 10/21/2005
- Sensor-Surface: (Fix Surface)
- Electronics: DAE3 Sn393; Calibrated: 9/5/2006
- Phantom: HAC Test Arch; Type: SD HAC P01 BA; Serial:
- Measurement SW: DAS4, V4.7 Build 44; Postprocessing SW: SEMCAD, V1.8 Build 171

**H Scan - H3DVV6 probe tip 10mm above Device Reference/Hearing Aid Compatibility Test (41x361x1):**

Measurement grid: dx=5mm, dy=5mm

Maximum value of peak Total field = 0.469 A/m

Probe Modulation Factor = 1.00

Reference Value = 0.500 A/m; Power Drift = -0.057 dB

**Hearing Aid Near-Field Category: M2 (AWF 0 dB)**

Peak H-field in A/m

Grid 1	Grid 2	Grid 3
<b>0.369</b>	<b>0.404</b>	<b>0.378</b>
Grid 4	Grid 5	Grid 6
<b>0.433</b>	<b>0.469</b>	<b>0.430</b>
Grid 7	Grid 8	Grid 9
<b>0.384</b>	<b>0.416</b>	<b>0.379</b>

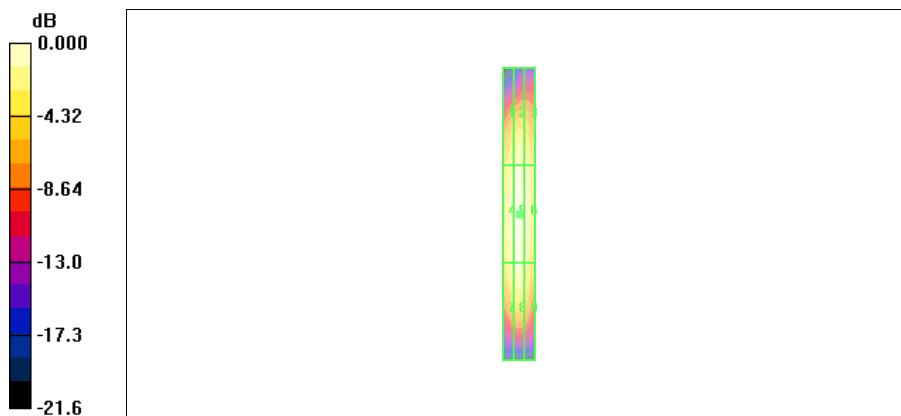

0 dB = 0.469A/m



Test Laboratory: A Test Lab Techno Corp.

Date/Time: 10/21/2006 9:24:10 AM

**System Performance Check at 835MHz\_20061021\_H**

**DUT: Dipole 835 MHz; Type: CD835V3; Serial: CD835V3 - SN:1017**

Communication System: CW; Frequency: 835 MHz; Duty Cycle: 1:1

Medium parameters used:  $\sigma = 0$  mho/m,  $\epsilon_r = 1$ ;  $\rho = 1$  kg/m<sup>3</sup>

Phantom section: H Dipole Section

Measurement Standard: DASYS4 (High Precision Assessment)

DASY4 Configuration:

- Probe: H3DV6 - SN6076; ; Calibrated: 10/21/2005
- Sensor-Surface: (Fix Surface)
- Electronics: DAE3 Sn393; Calibrated: 9/5/2006
- Phantom: HAC Test Arch; Type: SD HAC P01 BA; Serial:
- Measurement SW: DASYS4, V4.7 Build 44; Postprocessing SW: SEMCAD, V1.8 Build 171

**H Scan - H3DVV6 probe tip 10mm above Device Reference/Hearing Aid Compatibility Test (41x361x1):**

Measurement grid: dx=5mm, dy=5mm

Maximum value of peak Total field = 0.441 A/m

Probe Modulation Factor = 1.00

Reference Value = 0.466 A/m; Power Drift = -0.021 dB

**Hearing Aid Near-Field Category: M2 (AWF 0 dB)**

Peak H-field in A/m

Grid 1	Grid 2	Grid 3
<b>0.357</b>	<b>0.392</b>	<b>0.365</b>
Grid 4	Grid 5	Grid 6
<b>0.407</b>	<b>0.441</b>	<b>0.406</b>
Grid 7	Grid 8	Grid 9
<b>0.351</b>	<b>0.382</b>	<b>0.355</b>

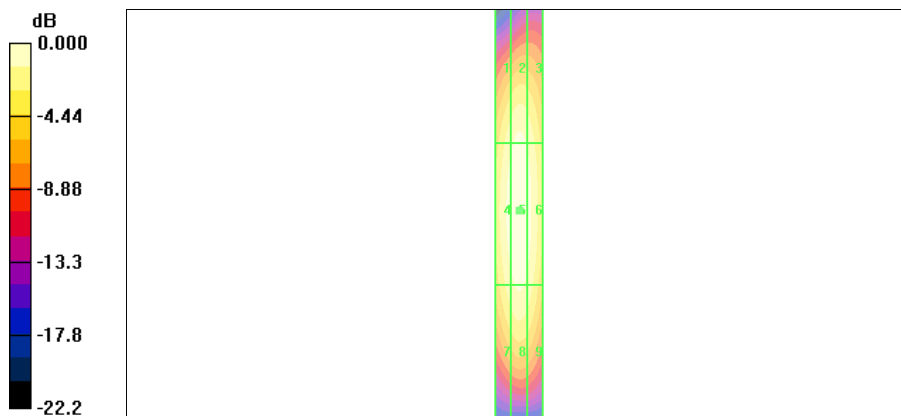



Test Laboratory: A Test Lab Techno Corp.

Date/Time: 12/12/2006 11:49:45 PM

**System Performance Check at 835MHz\_20061212\_H**

**DUT: Dipole 835 MHz; Type: CD835V3; Serial: CD835V3 - SN:1017**

Communication System: CW; Frequency: 835 MHz; Duty Cycle: 1:1

Medium parameters used:  $\sigma = 0$  mho/m,  $\epsilon_r = 1$ ;  $\rho = 1$  kg/m<sup>3</sup>

Phantom section: H Dipole Section

Measurement Standard: DAS4 (High Precision Assessment)

DASY4 Configuration:

- Probe: H3DV6 - SN6076; ; Calibrated: 10/21/2005
- Sensor-Surface: (Fix Surface)
- Electronics: DAE3 Sn393; Calibrated: 9/5/2006
- Phantom: HAC Test Arch; Type: SD HAC P01 BA; Serial:
- Measurement SW: DAS4, V4.7 Build 44; Postprocessing SW: SEMCAD, V1.8 Build 171

**H Scan - H3DVV6 probe tip 10mm above Device Reference/Hearing Aid Compatibility Test (41x361x1):**

Measurement grid: dx=5mm, dy=5mm

Maximum value of peak Total field = 0.448 A/m

Probe Modulation Factor = 1.00

Reference Value = 0.476 A/m; Power Drift = 0.004 dB

**Hearing Aid Near-Field Category: M2 (AWF 0 dB)**

Peak H-field in A/m

Grid 1	Grid 2	Grid 3
<b>0.358</b>	<b>0.400</b>	<b>0.378</b>
Grid 4	Grid 5	Grid 6
<b>0.412</b>	<b>0.448</b>	<b>0.412</b>
Grid 7	Grid 8	Grid 9
<b>0.373</b>	<b>0.401</b>	<b>0.358</b>

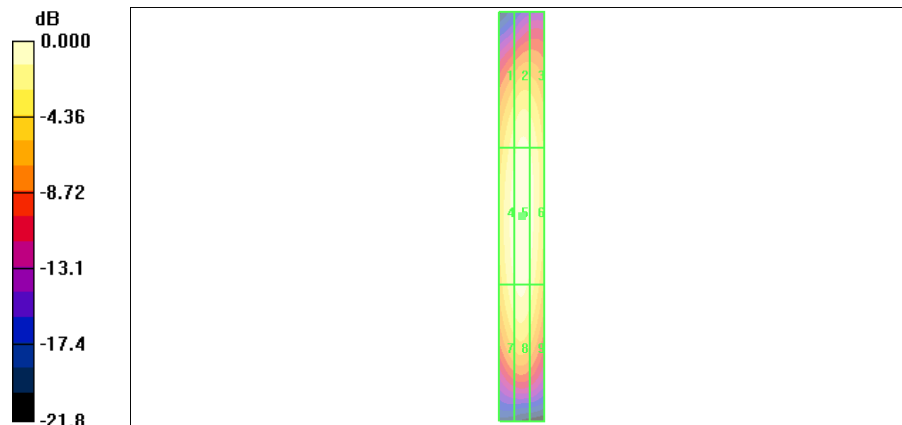

0 dB = 0.448A/m



Test Laboratory: A Test Lab Techno Corp.

Date/Time: 12/19/2006 8:23:26 AM

**System Performance Check at 835MHz\_20061219\_H**

**DUT: Dipole 835 MHz; Type: CD835V3; Serial: CD835V3 - SN:1017**

Communication System: CW; Frequency: 835 MHz; Duty Cycle: 1:1

Medium parameters used:  $\sigma = 0$  mho/m,  $\epsilon_r = 1$ ;  $\rho = 1$  kg/m<sup>3</sup>

Phantom section: H Dipole Section

Measurement Standard: DASYS4 (High Precision Assessment)

DASY4 Configuration:

- Probe: H3DV6 - SN6076; ; Calibrated: 10/21/2005
- Sensor-Surface: (Fix Surface)
- Electronics: DAE3 Sn393; Calibrated: 9/5/2006
- Phantom: HAC Test Arch; Type: SD HAC P01 BA; Serial:
- Measurement SW: DASY4, V4.7 Build 44; Postprocessing SW: SEMCAD, V1.8 Build 171

**H Scan - H3DV6 probe tip 10mm above Device Reference/Hearing Aid Compatibility Test (41x361x1):**

Measurement grid: dx=5mm, dy=5mm

Maximum value of peak Total field = 0.458 A/m

Probe Modulation Factor = 1.00

Reference Value = 0.489 A/m; Power Drift = -0.029 dB

**Hearing Aid Near-Field Category: M2 (AWF 0 dB)**

Peak H-field in A/m

Grid 1	Grid 2	Grid 3
<b>0.355</b>	<b>0.396</b>	<b>0.373</b>
Grid 4	Grid 5	Grid 6
<b>0.421</b>	<b>0.458</b>	<b>0.418</b>
Grid 7	Grid 8	Grid 9
<b>0.380</b>	<b>0.409</b>	<b>0.361</b>

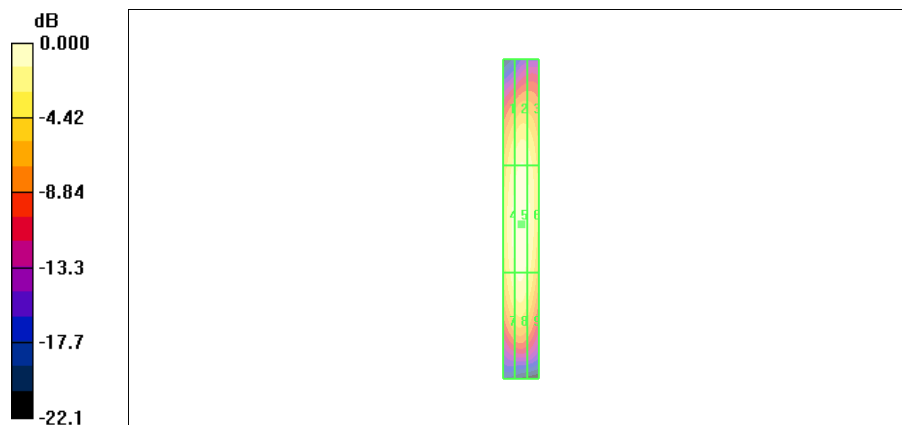





Test Laboratory: A Test Lab Techno Corp.

Date/Time: 12/26/2006 7:30:06 PM

**System Performance Check at 835MHz\_20061226\_H**

**DUT: Dipole 835 MHz; Type: CD835V3; Serial: CD835V3 - SN:1017**

Communication System: CW; Frequency: 835 MHz; Duty Cycle: 1:1

Medium parameters used:  $\sigma = 0$  mho/m,  $\epsilon_r = 1$ ;  $\rho = 1$  kg/m<sup>3</sup>

Phantom section: H Dipole Section

Measurement Standard: DASYS4 (High Precision Assessment)

DASY4 Configuration:

- Probe: H3DV6 - SN6076; ; Calibrated: 10/21/2005
- Sensor-Surface: (Fix Surface)
- Electronics: DAE4 Sn541; Calibrated: 10/16/2006
- Phantom: HAC Test Arch; Type: SD HAC P01 BA; Serial:
- Measurement SW: DASYS4, V4.7 Build 44; Postprocessing SW: SEMCAD, V1.8 Build 171

**H Scan - H3DV6 probe tip 10mm above Device Reference/Hearing Aid Compatibility Test (41x361x1):**

Measurement grid: dx=5mm, dy=5mm

Maximum value of peak Total field = 0.438 A/m

Probe Modulation Factor = 1.00

Reference Value = 0.464 A/m; Power Drift = -0.005 dB

**Hearing Aid Near-Field Category: M2 (AWF 0 dB)**

Peak H-field in A/m

Grid 1	Grid 2	Grid 3
<b>0.332</b>	<b>0.367</b>	<b>0.347</b>
Grid 4	Grid 5	Grid 6
<b>0.394</b>	<b>0.438</b>	<b>0.404</b>
Grid 7	Grid 8	Grid 9
<b>0.358</b>	<b>0.401</b>	<b>0.365</b>

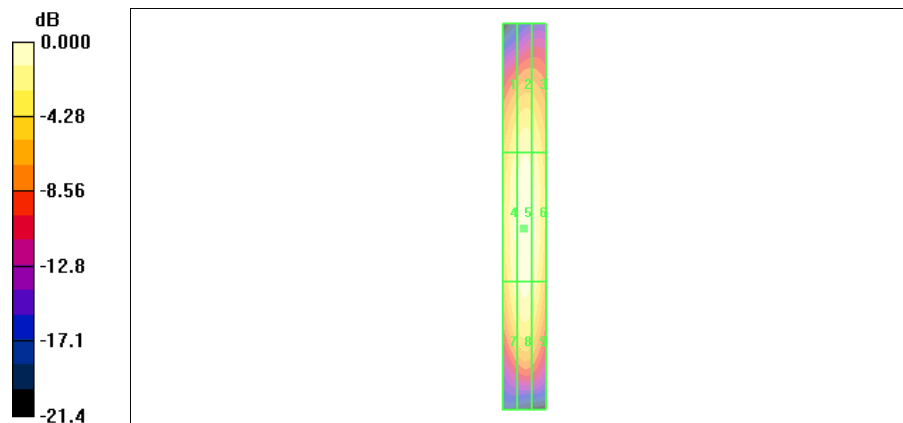

0 dB = 0.438A/m



Test Laboratory: A Test Lab Techno Corp.

Date/Time: 10/09/2006 5:36:19 PM

**System Performance Check at 1880MHz\_20061009\_H**

**DUT: Dipole 1880MHz; Type: CD1880V3; Serial: CD1880V3 - SN:1036**

Communication System: CW; Frequency: 1880 MHz; Duty Cycle: 1:1

Medium parameters used:  $\sigma = 0$  mho/m,  $\epsilon_r = 1$ ;  $\rho = 1$  kg/m<sup>3</sup>

Phantom section: H Dipole Section

Measurement Standard: DASYS4 (High Precision Assessment)

DASY4 Configuration:

- Probe: H3DV6 - SN6076; ; Calibrated: 10/21/2005
- Sensor-Surface: (Fix Surface)
- Electronics: DAE3 Sn393; Calibrated: 9/5/2006
- Phantom: HAC Test Arch; Type: SD HAC P01 BA; Serial:
- Measurement SW: DASYS4, V4.7 Build 44; Postprocessing SW: SEMCAD, V1.8 Build 171

**H Scan - H3DVV6 probe tip 10mm above Device Reference/Hearing Aid Compatibility Test (41x361x1):**

Measurement grid: dx=5mm, dy=5mm

Maximum value of peak Total field = 0.471 A/m

Probe Modulation Factor = 1.00

Reference Value = 0.467 A/m; Power Drift = -0.026 dB

**Hearing Aid Near-Field Category: M2 (AWF 0 dB)**

Peak H-field in A/m

Grid 1	Grid 2	Grid 3
<b>0.237</b>	<b>0.266</b>	<b>0.261</b>
Grid 4	Grid 5	Grid 6
<b>0.410</b>	<b>0.471</b>	<b>0.435</b>
Grid 7	Grid 8	Grid 9
<b>0.242</b>	<b>0.279</b>	<b>0.253</b>

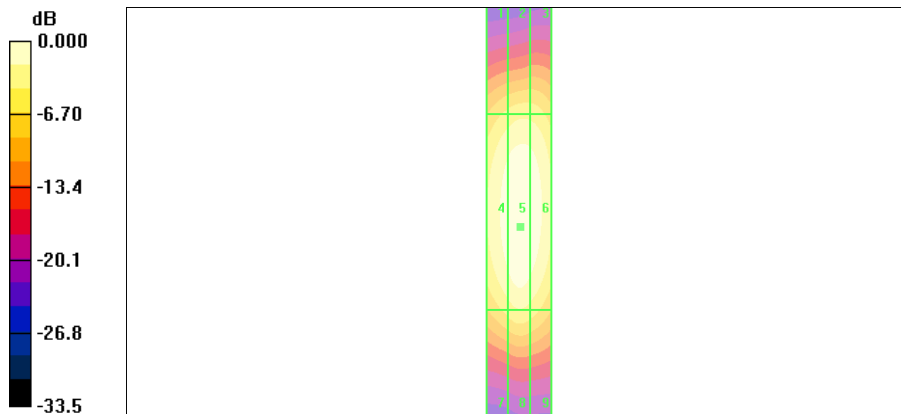

0 dB = 0.471A/m



Test Laboratory: A Test Lab Techno Corp.

Date/Time: 10/21/2006 10:20:37 AM

**System Performance Check at 1880MHz\_20061021\_H**

**DUT: Dipole 1880MHz; Type: CD1880V3; Serial: CD1880V3 - SN:1036**

Communication System: CW; Frequency: 1880 MHz; Duty Cycle: 1:1

Medium parameters used:  $\sigma = 0$  mho/m,  $\epsilon_r = 1$ ;  $\rho = 1$  kg/m<sup>3</sup>

Phantom section: H Dipole Section

Measurement Standard: DASYS4 (High Precision Assessment)

DASY4 Configuration:

- Probe: H3DV6 - SN6076; ; Calibrated: 10/21/2005
- Sensor-Surface: (Fix Surface)
- Electronics: DAE3 Sn393; Calibrated: 9/5/2006
- Phantom: HAC Test Arch; Type: SD HAC P01 BA; Serial:
- Measurement SW: DASYS4, V4.7 Build 44; Postprocessing SW: SEMCAD, V1.8 Build 171

**H Scan - H3DV6 probe tip 10mm above Device Reference/Hearing Aid Compatibility Test (41x181x1):**

Measurement grid: dx=5mm, dy=5mm

Maximum value of peak Total field = 0.454 A/m

Probe Modulation Factor = 1.00

Reference Value = 0.476 A/m; Power Drift = 0.041 dB

**Hearing Aid Near-Field Category: M2 (AWF 0 dB)**

Peak H-field in A/m

Grid 1	Grid 2	Grid 3
<b>0.384</b>	<b>0.418</b>	<b>0.385</b>
Grid 4	Grid 5	Grid 6
<b>0.423</b>	<b>0.454</b>	<b>0.421</b>
Grid 7	Grid 8	Grid 9
<b>0.384</b>	<b>0.412</b>	<b>0.384</b>

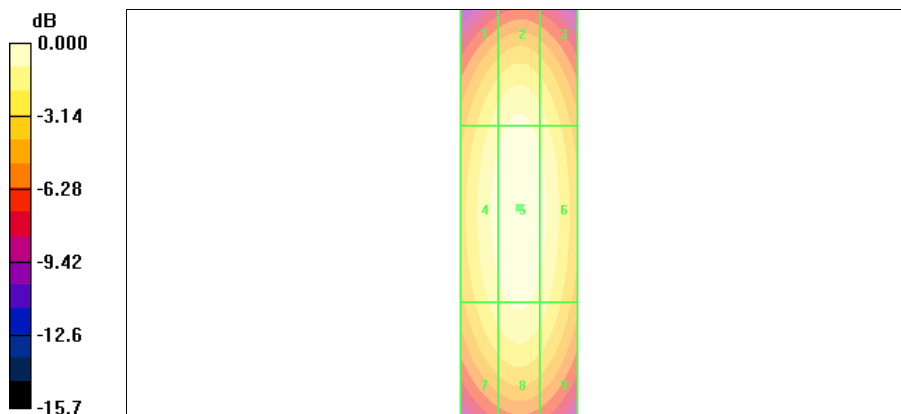

0 dB = 0.454A/m



Test Laboratory: A Test Lab Techno Corp.

Date/Time: 12/13/2006 12:14:56 AM

**System Performance Check at 1880MHz\_20061212\_H**

**DUT: Dipole 1880MHz; Type: CD1880V3; Serial: CD1880V3 - SN:1036**

Communication System: CW; Frequency: 1880 MHz; Duty Cycle: 1:1

Medium parameters used:  $\sigma = 0$  mho/m,  $\epsilon_r = 1$ ;  $\rho = 1$  kg/m<sup>3</sup>

Phantom section: H Dipole Section

Measurement Standard: DAS4 (High Precision Assessment)

DASY4 Configuration:

- Probe: H3DV6 - SN6076; ; Calibrated: 10/21/2005
- Sensor-Surface: (Fix Surface)
- Electronics: DAE3 Sn393; Calibrated: 9/5/2006
- Phantom: HAC Test Arch; Type: SD HAC P01 BA; Serial:
- Measurement SW: DAS4, V4.7 Build 44; Postprocessing SW: SEMCAD, V1.8 Build 171

**H Scan - H3DVV6 probe tip 10mm above Device Reference/Hearing Aid Compatibility Test (41x361x1):**

Measurement grid: dx=5mm, dy=5mm

Maximum value of peak Total field = 0.437 A/m

Probe Modulation Factor = 1.00

Reference Value = 0.461 A/m; Power Drift = 0.012 dB

**Hearing Aid Near-Field Category: M2 (AWF 0 dB)**

Peak H-field in A/m

Grid 1	Grid 2	Grid 3
<b>0.249</b>	<b>0.276</b>	<b>0.258</b>
Grid 4	Grid 5	Grid 6
<b>0.403</b>	<b>0.437</b>	<b>0.403</b>
Grid 7	Grid 8	Grid 9
<b>0.222</b>	<b>0.236</b>	<b>0.217</b>

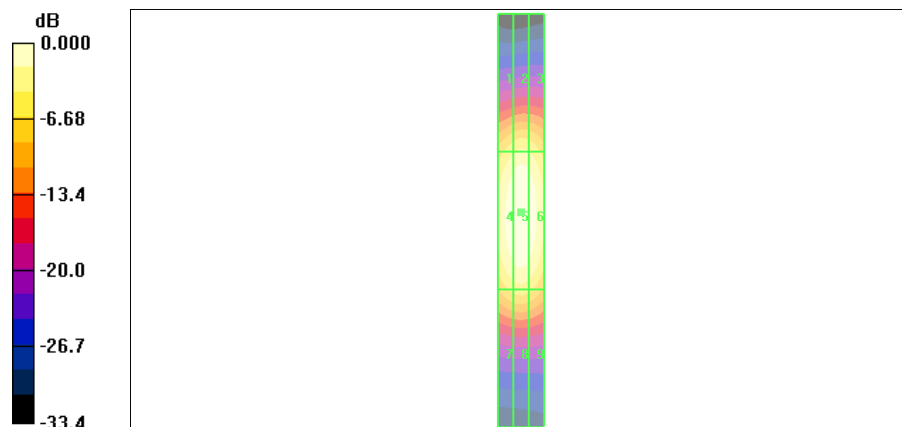

0 dB = 0.437A/m



Test Laboratory: A Test Lab Techno Corp.

Date/Time: 12/19/2006 8:58:14 AM

**System Performance Check at 1880MHz\_20061219\_H**

**DUT: Dipole 1880MHz; Type: CD1880V3; Serial: CD1880V3 - SN:1036**

Communication System: CW; Frequency: 1880 MHz; Duty Cycle: 1:1

Medium parameters used:  $\sigma = 0$  mho/m,  $\epsilon_r = 1$ ;  $\rho = 1$  kg/m<sup>3</sup>

Phantom section: H Dipole Section

Measurement Standard: DASYS4 (High Precision Assessment)

DASY4 Configuration:

- Probe: H3DV6 - SN6076; ; Calibrated: 10/21/2005
- Sensor-Surface: (Fix Surface)
- Electronics: DAE3 Sn393; Calibrated: 9/5/2006
- Phantom: HAC Test Arch; Type: SD HAC P01 BA; Serial:
- Measurement SW: DASY4, V4.7 Build 44; Postprocessing SW: SEMCAD, V1.8 Build 171

**H Scan - H3DV6 probe tip 10mm above Device Reference/Hearing Aid Compatibility Test (41x181x1):**

Measurement grid: dx=5mm, dy=5mm

Maximum value of peak Total field = 0.489 A/m

Probe Modulation Factor = 1.00

Reference Value = 0.518 A/m; Power Drift = -0.012 dB

**Hearing Aid Near-Field Category: M2 (AWF 0 dB)**

Peak H-field in A/m

Grid 1	Grid 2	Grid 3
<b>0.414</b>	<b>0.452</b>	<b>0.418</b>
Grid 4	Grid 5	Grid 6
<b>0.453</b>	<b>0.489</b>	<b>0.450</b>
Grid 7	Grid 8	Grid 9
<b>0.412</b>	<b>0.442</b>	<b>0.401</b>

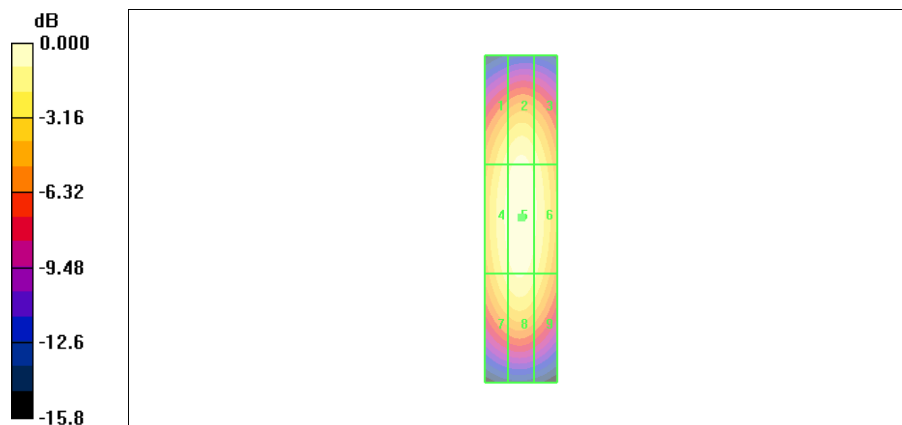

0 dB = 0.489A/m



Test Laboratory: A Test Lab Techno Corp.

Date/Time: 12/26/2006 6:53:27 PM

**System Performance Check at 1880MHz\_20061226\_H**

**DUT: Dipole 1880MHz; Type: CD1880V3; Serial: CD1880V3 - SN:1036**

Communication System: CW; Frequency: 1880 MHz; Duty Cycle: 1:1

Medium parameters used:  $\sigma = 0$  mho/m,  $\epsilon_r = 1$ ;  $\rho = 1$  kg/m<sup>3</sup>

Phantom section: H Dipole Section

Measurement Standard: DASYS4 (High Precision Assessment)

DASY4 Configuration:

- Probe: H3DV6 - SN6076; ; Calibrated: 10/21/2005
- Sensor-Surface: (Fix Surface)
- Electronics: DAE4 Sn541; Calibrated: 10/16/2006
- Phantom: HAC Test Arch; Type: SD HAC P01 BA; Serial:
- Measurement SW: DASY4, V4.7 Build 44; Postprocessing SW: SEMCAD, V1.8 Build 171

**H Scan - H3DVV6 probe tip 10mm above Device Reference/Hearing Aid Compatibility Test (41x181x1):**

Measurement grid: dx=5mm, dy=5mm

Maximum value of peak Total field = 0.461 A/m

Probe Modulation Factor = 1.00

Reference Value = 0.489 A/m; Power Drift = -0.004 dB

**Hearing Aid Near-Field Category: M2 (AWF 0 dB)**

Peak H-field in A/m

Grid 1	Grid 2	Grid 3
<b>0.384</b>	<b>0.424</b>	<b>0.394</b>
Grid 4	Grid 5	Grid 6
<b>0.421</b>	<b>0.461</b>	<b>0.428</b>
Grid 7	Grid 8	Grid 9
<b>0.383</b>	<b>0.421</b>	<b>0.386</b>

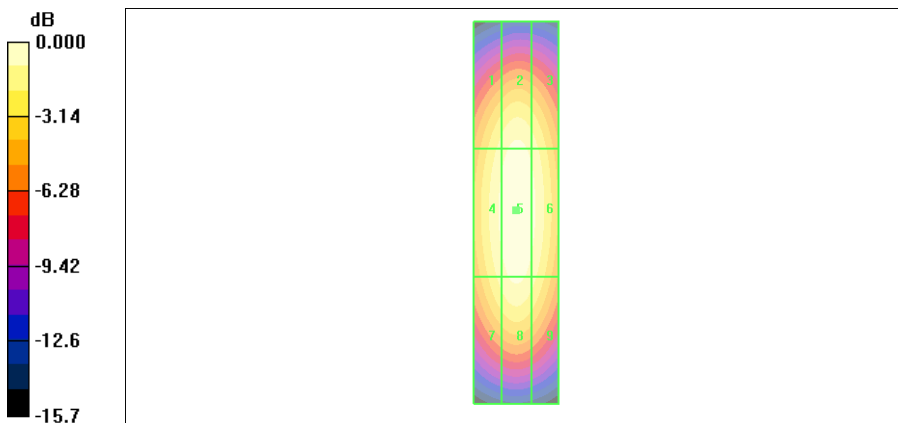

0 dB = 0.461 A/m



Test Laboratory: A Test Lab Techno Corp.

Date/Time: 10/09/2006 9:01:22 PM

**System Performance Check at 2450MHz\_20061009\_H**

**DUT: Dipole 2450 MHz; Type: CD2450V2; Serial: CD2450V3 - SN:1037**

Communication System: CW; Frequency: 2450 MHz; Duty Cycle: 1:1

Medium parameters used:  $\sigma = 0$  mho/m,  $\epsilon_r = 1$ ;  $\rho = 1$  kg/m<sup>3</sup>

Phantom section: H Dipole Section

Measurement Standard: DASYS4 (High Precision Assessment)

DASY4 Configuration:

- Probe: H3DV6 - SN6076; ; Calibrated: 10/21/2005
- Sensor-Surface: (Fix Surface)
- Electronics: DAE3 Sn393; Calibrated: 9/5/2006
- Phantom: HAC Test Arch; Type: SD HAC P01 BA; Serial:
- Measurement SW: DASYS4, V4.7 Build 44; Postprocessing SW: SEMCAD, V1.8 Build 171

**H Scan - H3DVV6 probe tip 10mm above Device Reference/Hearing Aid Compatibility Test (41x181x1):**

Measurement grid: dx=5mm, dy=5mm

Maximum value of peak Total field = 0.501 A/m

Probe Modulation Factor = 1.00

Reference Value = 0.533 A/m; Power Drift = -0.080 dB

**Hearing Aid Near-Field Category: M2 (AWF 0 dB)**

Peak H-field in A/m

Grid 1	Grid 2	Grid 3
<b>0.396</b>	<b>0.424</b>	<b>0.387</b>
Grid 4	Grid 5	Grid 6
<b>0.468</b>	<b>0.501</b>	<b>0.456</b>
Grid 7	Grid 8	Grid 9
<b>0.380</b>	<b>0.405</b>	<b>0.369</b>

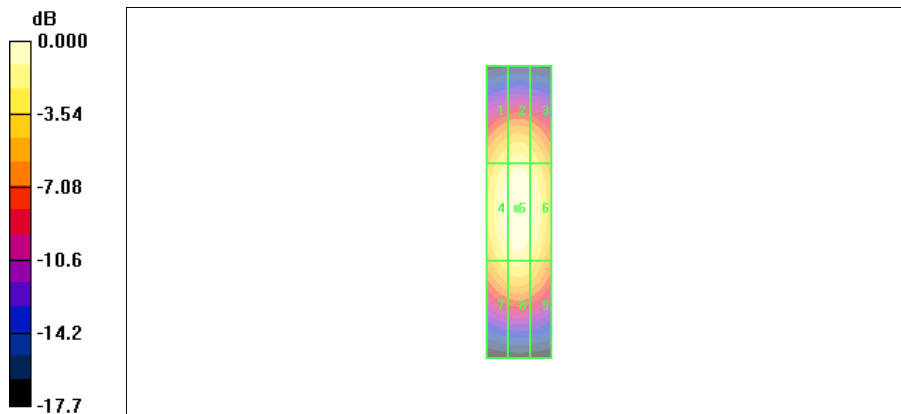

0 dB = 0.501A/m



Test Laboratory: A Test Lab Techno Corp.

Date/Time: 10/21/2006 10:55:24 AM

**System Performance Check at 2450MHz\_20061021\_H**

**DUT: Dipole 2450 MHz; Type: CD2450V2; Serial: CD2450V3 - SN:1037**

Communication System: CW; Frequency: 2450 MHz; Duty Cycle: 1:1

Medium parameters used:  $\sigma = 0$  mho/m,  $\epsilon_r = 1$ ;  $\rho = 1$  kg/m<sup>3</sup>

Phantom section: H Dipole Section

Measurement Standard: DASYS4 (High Precision Assessment)

DASY4 Configuration:

- Probe: H3DV6 - SN6076; ; Calibrated: 10/21/2005
- Sensor-Surface: (Fix Surface)
- Electronics: DAE3 Sn393; Calibrated: 9/5/2006
- Phantom: HAC Test Arch; Type: SD HAC P01 BA; Serial:
- Measurement SW: DASY4, V4.7 Build 44; Postprocessing SW: SEMCAD, V1.8 Build 171

**H Scan - H3DVV6 probe tip 10mm above Device Reference/Hearing Aid Compatibility Test (41x181x1):**

Measurement grid: dx=5mm, dy=5mm

Maximum value of peak Total field = 0.511 A/m

Probe Modulation Factor = 1.00

Reference Value = 0.542 A/m; Power Drift = -0.029 dB

**Hearing Aid Near-Field Category: M2 (AWF 0 dB)**

Peak H-field in A/m

Grid 1	Grid 2	Grid 3
<b>0.402</b>	<b>0.435</b>	<b>0.397</b>
Grid 4	Grid 5	Grid 6
<b>0.475</b>	<b>0.511</b>	<b>0.470</b>
Grid 7	Grid 8	Grid 9
<b>0.384</b>	<b>0.413</b>	<b>0.384</b>

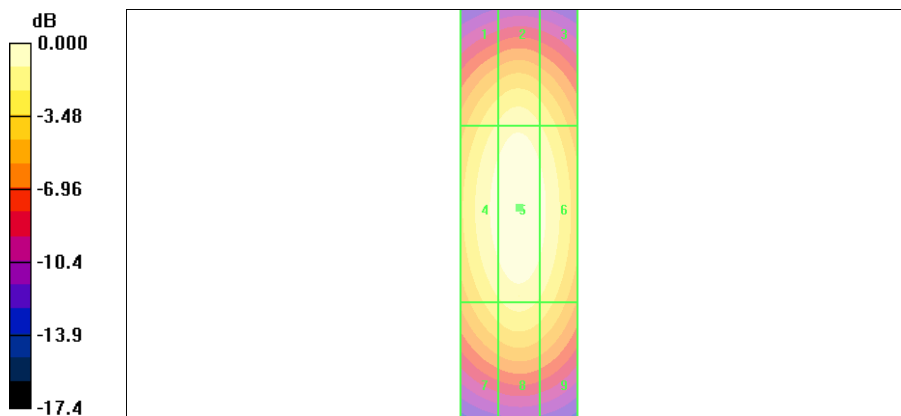

0 dB = 0.511A/m





***Appendix C - TITA100 – Mode 1 HAC distribution plots for E-Field and H-Field***

See following Attached Pages for HAC distribution plots for E-Field and H-Field.



A Test Lab Techno Corp.

Date/Time: 10/9/2006 4:51:14 PM

**CDMA 850 CH1013\_E**

**DUT: TTTA100; Type:Pocket PC Phone; FCC ID:NM8TITA100**

Communication System: CDMA; Frequency: 824.7 MHz;Duty Cycle: 1:1

Medium parameters used:  $\sigma = 0$  mho/m,  $\epsilon_r = 1$ ;  $\rho = 1000$  kg/m<sup>3</sup>

Phantom section: E Device Section

Measurement Standard: DAS4 (High Precision Assessment)

DASY4 Configuration:

- Probe: ER3DV6 - SN2256; ConvF(1, 1, 1); Calibrated: 10/21/2005
- Sensor-Surface: (Fix Surface)
- Electronics: DAE3 Sn393; Calibrated: 9/5/2006
- Phantom: HAC Test Arch; Type: SD HAC P01 BA; Serial:
- Measurement SW: DAS4, V4.7 Build 44; Postprocessing SW: SEMCAD, V1.8 Build 171

**E Scan - ER3DV6 probe center 10mm above Device Reference/Hearing Aid Compatibility Test (101x101x1):**

Measurement grid: dx=5mm, dy=5mm

Maximum value of peak Total field = 150.8 V/m

Probe Modulation Factor = 1.33

Reference Value = 104.2 V/m; Power Drift = -0.025 dB

**Hearing Aid Near-Field Category: M4 (AWF 0 dB)**

Peak E-field in V/m

Grid 1	Grid 2	Grid 3
<b>76.6</b>	<b>117.9</b>	<b>117.8</b>
Grid 4	Grid 5	Grid 6
<b>94.8</b>	<b>150.8</b>	<b>149.0</b>
Grid 7	Grid 8	Grid 9
<b>105.8</b>	<b>151.0</b>	<b>147.8</b>

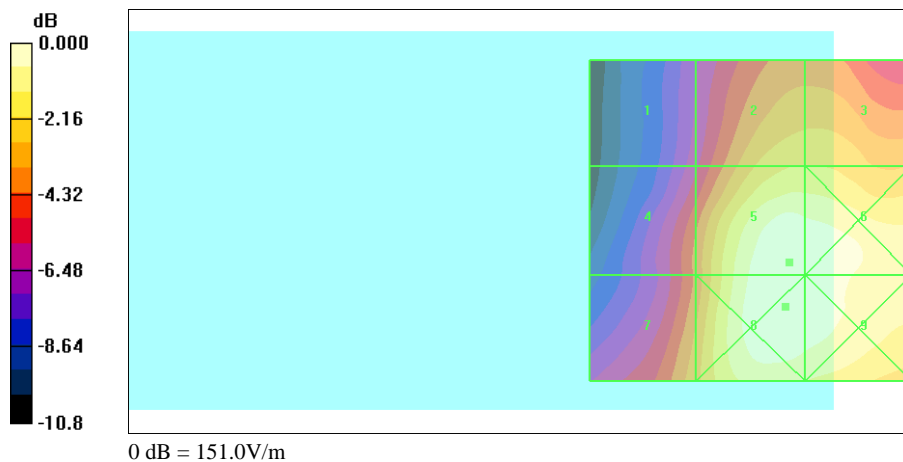



A Test Lab Techno Corp.

Date/Time: 10/9/2006 4:57:44 PM

**CDMA 850 CH384\_E**

**DUT: TTTA100; Type:Pocket PC Phone; FCC ID:NM8TITA100**

Communication System: CDMA; Frequency: 836.52 MHz;Duty Cycle: 1:1

Medium parameters used:  $\sigma = 0$  mho/m,  $\epsilon_r = 1$ ;  $\rho = 1000$  kg/m<sup>3</sup>

Phantom section: E Device Section

Measurement Standard: DAS4 (High Precision Assessment)

DASY4 Configuration:

- Probe: ER3DV6 - SN2256; ConvF(1, 1, 1); Calibrated: 10/21/2005
- Sensor-Surface: (Fix Surface)
- Electronics: DAE3 Sn393; Calibrated: 9/5/2006
- Phantom: HAC Test Arch; Type: SD HAC P01 BA; Serial:
- Measurement SW: DASY4, V4.7 Build 44; Postprocessing SW: SEMCAD, V1.8 Build 171

**E Scan - ER3DV6 probe center 10mm above Device Reference/Hearing Aid Compatibility Test (101x101x1):**

Measurement grid: dx=5mm, dy=5mm

Maximum value of peak Total field = 169.5 V/m

Probe Modulation Factor = 1.33

Reference Value = 117.8 V/m; Power Drift = 0.058 dB

**Hearing Aid Near-Field Category: M4 (AWF 0 dB)**

Peak E-field in V/m

Grid 1	Grid 2	Grid 3
<b>88.0</b>	<b>132.2</b>	<b>131.9</b>
Grid 4	Grid 5	Grid 6
<b>108.7</b>	<b>169.5</b>	<b>166.7</b>
Grid 7	Grid 8	Grid 9
<b>120.3</b>	<b>169.2</b>	<b>165.3</b>

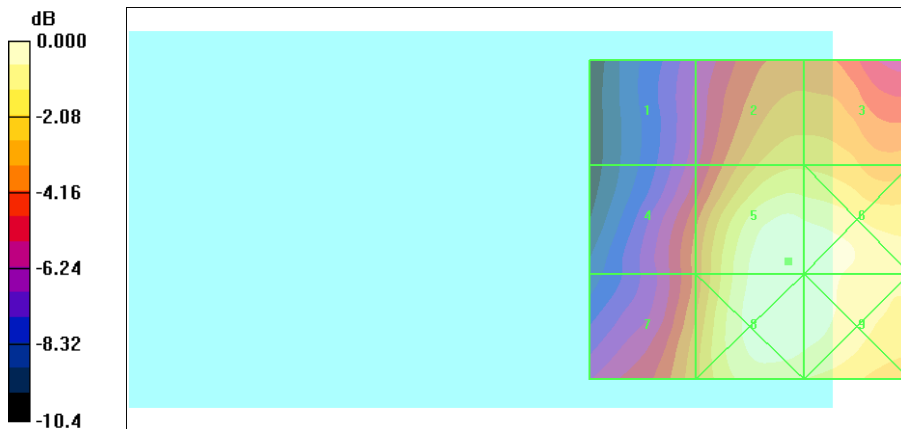

0 dB = 169.5V/m



A Test Lab Techno Corp.

Date/Time: 10/9/2006 5:03:53 PM

**CDMA 850 CH777\_E**

**DUT: TTTA100; Type:Pocket PC Phone; FCC ID:NM8TITA100**

Communication System: CDMA; Frequency: 848.31 MHz;Duty Cycle: 1:1

Medium parameters used:  $\sigma = 0$  mho/m,  $\epsilon_r = 1$ ;  $\rho = 1000$  kg/m<sup>3</sup>

Phantom section: E Device Section

Measurement Standard: DASYS4 (High Precision Assessment)

DASY4 Configuration:

- Probe: ER3DV6 - SN2256; ConvF(1, 1, 1); Calibrated: 10/21/2005
- Sensor-Surface: (Fix Surface)
- Electronics: DAE3 Sn393; Calibrated: 9/5/2006
- Phantom: HAC Test Arch; Type: SD HAC P01 BA; Serial:
- Measurement SW: DASYS4, V4.7 Build 44; Postprocessing SW: SEMCAD, V1.8 Build 171

**E Scan - ER3DV6 probe center 10mm above Device Reference/Hearing Aid Compatibility Test (101x101x1):**

Measurement grid: dx=5mm, dy=5mm

Maximum value of peak Total field = 148.6 V/m

Probe Modulation Factor = 1.33

Reference Value = 105.6 V/m; Power Drift = -0.056 dB

**Hearing Aid Near-Field Category: M4 (AWF 0 dB)**

Peak E-field in V/m

Grid 1	Grid 2	Grid 3
<b>80.5</b>	<b>116.6</b>	<b>115.8</b>
Grid 4	Grid 5	Grid 6
<b>98.7</b>	<b>148.6</b>	<b>146.1</b>
Grid 7	Grid 8	Grid 9
<b>109.3</b>	<b>150.2</b>	<b>145.3</b>

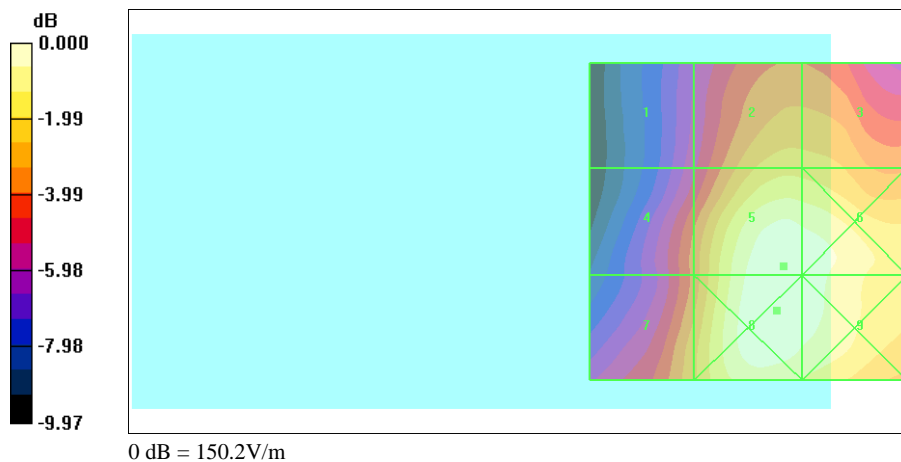



A Test Lab Techno Corp.

Date/Time: 10/9/2006 4:28:18 PM

**CDMA 1900 CH25\_E**

**DUT: TTTA100; Type:Pocket PC Phone; FCC ID:NM8TITA100**

Communication System: PCS 1900; Frequency: 1851.25 MHz;Duty Cycle: 1:1

Medium parameters used:  $\sigma = 0$  mho/m,  $\epsilon_r = 1$ ;  $\rho = 1000$  kg/m<sup>3</sup>

Phantom section: E Device Section

Measurement Standard: DASYS4 (High Precision Assessment)

DASY4 Configuration:

- Probe: ER3DV6 - SN2256; ConvF(1, 1, 1); Calibrated: 10/21/2005
- Sensor-Surface: (Fix Surface)
- Electronics: DAE3 Sn393; Calibrated: 9/5/2006
- Phantom: HAC Test Arch; Type: SD HAC P01 BA; Serial:
- Measurement SW: DASYS4, V4.7 Build 44; Postprocessing SW: SEMCAD, V1.8 Build 171

**E Scan - ER3DV6 probe center 10mm above Device Reference/Hearing Aid Compatibility Test (101x101x1):**

Measurement grid: dx=5mm, dy=5mm

Maximum value of peak Total field = 74.3 V/m

Probe Modulation Factor = 1.06

Reference Value = 57.1 V/m; Power Drift = -0.029 dB

**Hearing Aid Near-Field Category: M3 (AWF 0 dB)**

Peak E-field in V/m

Grid 1	Grid 2	Grid 3
<b>58.0</b>	<b>72.6</b>	<b>71.2</b>
Grid 4	Grid 5	Grid 6
<b>59.2</b>	<b>74.3</b>	<b>68.0</b>
Grid 7	Grid 8	Grid 9
<b>97.0</b>	<b>104.3</b>	<b>87.9</b>

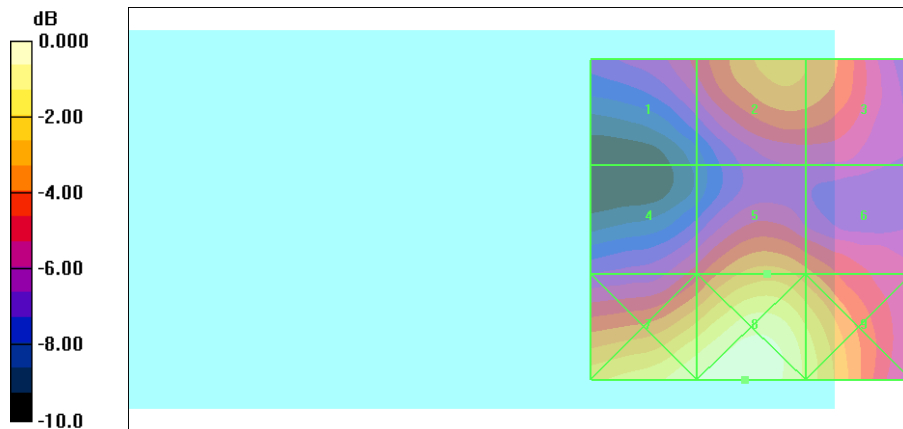

0 dB = 104.3V/m



A Test Lab Techno Corp.

Date/Time: 10/9/2006 4:35:28 PM

**CDMA 1900 CH600\_E**

**DUT: TTTA100; Type:Pocket PC Phone; FCC ID:NM8TITA100**

Communication System: PCS 1900; Frequency: 1880 MHz;Duty Cycle: 1:1

Medium parameters used:  $\sigma = 0$  mho/m,  $\epsilon_r = 1$ ;  $\rho = 1000$  kg/m<sup>3</sup>

Phantom section: E Device Section

Measurement Standard: DASYS4 (High Precision Assessment)

DASY4 Configuration:

- Probe: ER3DV6 - SN2256; ConvF(1, 1, 1); Calibrated: 10/21/2005
- Sensor-Surface: (Fix Surface)
- Electronics: DAE3 Sn393; Calibrated: 9/5/2006
- Phantom: HAC Test Arch; Type: SD HAC P01 BA; Serial:
- Measurement SW: DASYS4, V4.7 Build 44; Postprocessing SW: SEMCAD, V1.8 Build 171

**E Scan - ER3DV6 probe center 10mm above Device Reference/Hearing Aid Compatibility Test (101x101x1):**

Measurement grid: dx=5mm, dy=5mm

Maximum value of peak Total field = 82.0 V/m

Probe Modulation Factor = 1.06

Reference Value = 55.2 V/m; Power Drift = -0.128 dB

**Hearing Aid Near-Field Category: M3 (AWF 0 dB)**

Peak E-field in V/m

Grid 1	Grid 2	Grid 3
<b>67.7</b>	<b>82.0</b>	<b>79.6</b>
Grid 4	Grid 5	Grid 6
<b>57.2</b>	<b>73.5</b>	<b>68.9</b>
Grid 7	Grid 8	Grid 9
<b>101.4</b>	<b>109.5</b>	<b>92.9</b>

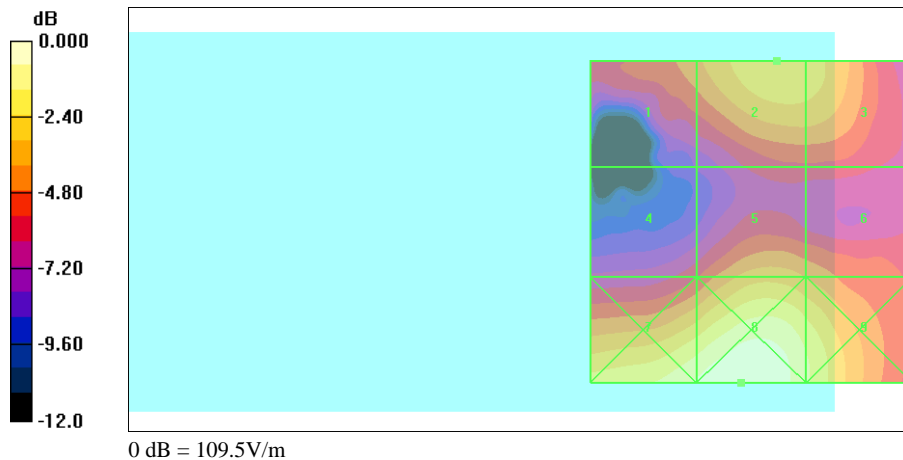



A Test Lab Techno Corp.

Date/Time: 10/9/2006 4:42:17 PM

**CDMA 1900 CH1175\_E**

**DUT: TTTA100; Type:Pocket PC Phone; FCC ID:NM8TITA100**

Communication System: PCS 1900; Frequency: 1908.75 MHz;Duty Cycle: 1:1

Medium parameters used:  $\sigma = 0$  mho/m,  $\epsilon_r = 1$ ;  $\rho = 1000$  kg/m<sup>3</sup>

Phantom section: E Device Section

Measurement Standard: DAS4 (High Precision Assessment)

DASY4 Configuration:

- Probe: ER3DV6 - SN2256; ConvF(1, 1, 1); Calibrated: 10/21/2005
- Sensor-Surface: (Fix Surface)
- Electronics: DAE3 Sn393; Calibrated: 9/5/2006
- Phantom: HAC Test Arch; Type: SD HAC P01 BA; Serial:
- Measurement SW: DAS4, V4.7 Build 44; Postprocessing SW: SEMCAD, V1.8 Build 171

**E Scan - ER3DV6 probe center 10mm above Device Reference/Hearing Aid Compatibility Test (101x101x1):**

Measurement grid: dx=5mm, dy=5mm

Maximum value of peak Total field = 86.3 V/m

Probe Modulation Factor = 1.06

Reference Value = 50.6 V/m; Power Drift = -0.134 dB

**Hearing Aid Near-Field Category: M3 (AWF 0 dB)**

Peak E-field in V/m

Grid 1	Grid 2	Grid 3
<b>70.7</b>	<b>86.3</b>	<b>83.7</b>
Grid 4	Grid 5	Grid 6
<b>50.4</b>	<b>66.0</b>	<b>63.5</b>
Grid 7	Grid 8	Grid 9
<b>95.0</b>	<b>102.5</b>	<b>88.0</b>

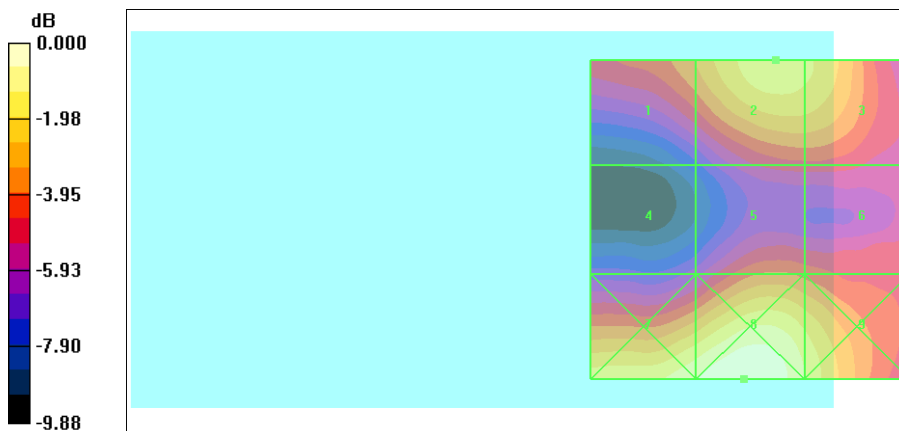

0 dB = 102.5V/m



Test Laboratory: A Test Lab Techno Corp.

Date/Time: 12/13/2006 1:31:14 AM

**HAC\_CDMA Cellular CH1013\_802.11b CH1\_E**

**DUT: TITA100; Type:Pocket PC Phone; FCC ID:NM8TITA100**

Communication System: CDMA Cellular ; Frequency: 824.7 MHz;Duty Cycle: 1:1

Medium parameters used:  $\sigma = 0$  mho/m,  $\epsilon_r = 1$ ;  $\rho = 1000$  kg/m<sup>3</sup>

Phantom section: E Device Section

Measurement Standard: DASYS4 (High Precision Assessment)

DASY4 Configuration:

- Probe: ER3DV6 - SN2256; ConvF(1, 1, 1); Calibrated: 10/21/2005
- Sensor-Surface: (Fix Surface)
- Electronics: DAE3 Sn393; Calibrated: 9/5/2006
- Phantom: HAC Test Arch; Type: SD HAC P01 BA; Serial:
- Measurement SW: DASYS4, V4.7 Build 44; Postprocessing SW: SEMCAD, V1.8 Build 171

**E Scan - ER3DV6 probe center 10mm above Device Reference/Hearing Aid Compatibility Test (101x101x1):**

Measurement grid: dx=5mm, dy=5mm

Maximum value of peak Total field = 142.6 V/m

Probe Modulation Factor = 1.33

Reference Value = 93.2 V/m; Power Drift = 0.030 dB

**Hearing Aid Near-Field Category: M4 (AWF 0 dB)**

Peak E-field in V/m

Grid 1	Grid 2	Grid 3
<b>57.3</b>	<b>100.4</b>	<b>107.4</b>
Grid 4	Grid 5	Grid 6
<b>79.5</b>	<b>142.6</b>	<b>139.1</b>
Grid 7	Grid 8	Grid 9
<b>91.7</b>	<b>144.1</b>	<b>138.9</b>

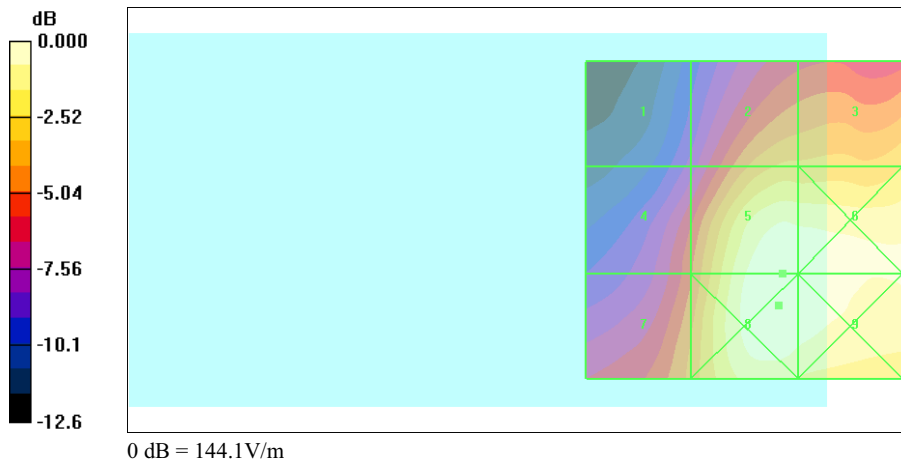





Test Laboratory: A Test Lab Techno Corp.

Date/Time: 12/13/2006 1:16:44 AM

**HAC\_CDMA Cellular CH384\_802.11b CH1\_E**

**DUT: TITA100; Type:Pocket PC Phone; FCC ID:NM8TITA100**

Communication System: CDMA Cellular ; Frequency: 836.52 MHz;Duty Cycle: 1:1

Medium parameters used:  $\sigma = 0$  mho/m,  $\epsilon_r = 1$ ;  $\rho = 1000$  kg/m<sup>3</sup>

Phantom section: E Device Section

Measurement Standard: DASYS4 (High Precision Assessment)

DASY4 Configuration:

- Probe: ER3DV6 - SN2256; ConvF(1, 1, 1); Calibrated: 10/21/2005
- Sensor-Surface: (Fix Surface)
- Electronics: DAE3 Sn393; Calibrated: 9/5/2006
- Phantom: HAC Test Arch; Type: SD HAC P01 BA; Serial:
- Measurement SW: DASYS4, V4.7 Build 44; Postprocessing SW: SEMCAD, V1.8 Build 171

**E Scan - ER3DV6 probe center 10mm above Device Reference/Hearing Aid Compatibility Test (101x101x1):**

Measurement grid: dx=5mm, dy=5mm

Maximum value of peak Total field = 158.0 V/m

Probe Modulation Factor = 1.33

Reference Value = 103.3 V/m; Power Drift = 0.044 dB

**Hearing Aid Near-Field Category: M4 (AWF 0 dB)**

Peak E-field in V/m

Grid 1	Grid 2	Grid 3
<b>64.0</b>	<b>112.9</b>	<b>119.5</b>
Grid 4	Grid 5	Grid 6
<b>88.8</b>	<b>158.0</b>	<b>155.1</b>
Grid 7	Grid 8	Grid 9
<b>103.1</b>	<b>160.7</b>	<b>155.8</b>

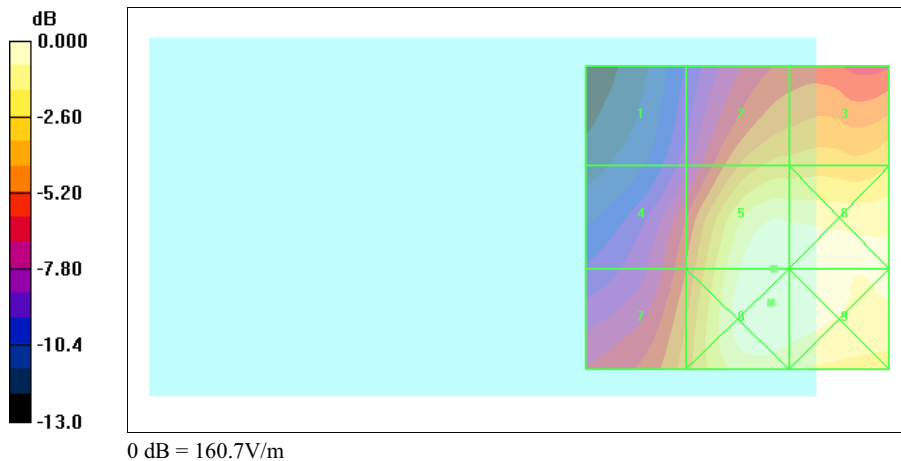



Test Laboratory: A Test Lab Techno Corp.

Date/Time: 12/13/2006 1:22:23 AM

**HAC\_CDMA Cellular CH777\_802.11b CH1\_E**

**DUT:TITA100; Type:Pocket PC Phone; FCC ID:NM8TITA100**

Communication System: CDMA Cellular ; Frequency: 848.31 MHz;Duty Cycle: 1:1

Medium parameters used:  $\sigma = 0$  mho/m,  $\epsilon_r = 1$ ;  $\rho = 1000$  kg/m<sup>3</sup>

Phantom section: E Device Section

Measurement Standard: DASYS4 (High Precision Assessment)

DASY4 Configuration:

- Probe: ER3DV6 - SN2256; ConvF(1, 1, 1); Calibrated: 10/21/2005
- Sensor-Surface: (Fix Surface)
- Electronics: DAE3 Sn393; Calibrated: 9/5/2006
- Phantom: HAC Test Arch; Type: SD HAC P01 BA; Serial:
- Measurement SW: DASYS4, V4.7 Build 44; Postprocessing SW: SEMCAD, V1.8 Build 171

**E Scan - ER3DV6 probe center 10mm above Device Reference/Hearing Aid Compatibility Test (101x101x1):**

Measurement grid: dx=5mm, dy=5mm

Maximum value of peak Total field = 128.5 V/m

Probe Modulation Factor = 1.33

Reference Value = 84.1 V/m; Power Drift = 0.032 dB

**Hearing Aid Near-Field Category: M4 (AWF 0 dB)**

Peak E-field in V/m

Grid 1	Grid 2	Grid 3
<b>55.2</b>	<b>92.1</b>	<b>95.2</b>
Grid 4	Grid 5	Grid 6
<b>73.1</b>	<b>128.5</b>	<b>126.0</b>
Grid 7	Grid 8	Grid 9
<b>84.5</b>	<b>130.2</b>	<b>127.0</b>

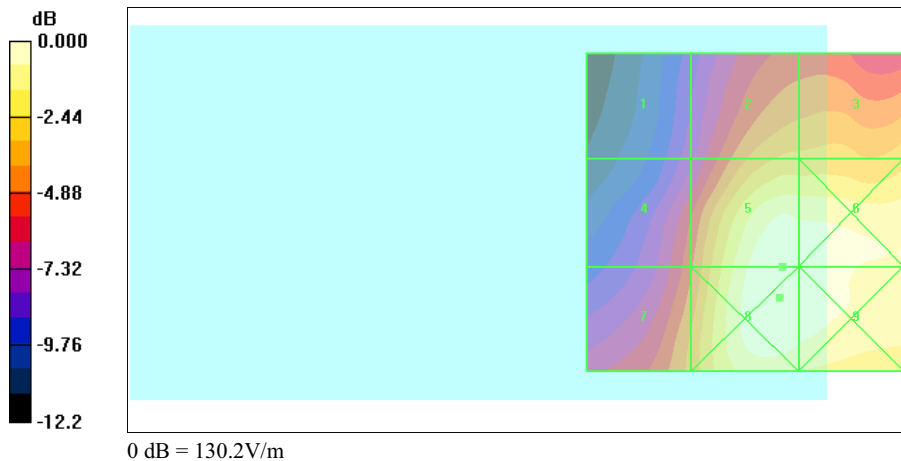



Test Laboratory: A Test Lab Techno Corp.

Date/Time: 12/13/2006 1:43:15 AM

**HAC\_CDMA PCS CH25\_802.11b CH1\_E**

**DUT: TITA100; Type:Pocket PC Phone; FCC ID:NM8TITA100**

Communication System: CDMA PCS ; Frequency: 1851.25 MHz;Duty Cycle: 1:1

Medium parameters used:  $\sigma = 0$  mho/m,  $\epsilon_r = 1$ ;  $\rho = 1000$  kg/m<sup>3</sup>

Phantom section: E Device Section

Measurement Standard: DASYS4 (High Precision Assessment)

DASY4 Configuration:

- Probe: ER3DV6 - SN2256; ConvF(1, 1, 1); Calibrated: 10/21/2005
- Sensor-Surface: (Fix Surface)
- Electronics: DAE3 Sn393; Calibrated: 9/5/2006
- Phantom: HAC Test Arch; Type: SD HAC P01 BA; Serial:
- Measurement SW: DASYS4, V4.7 Build 44; Postprocessing SW: SEMCAD, V1.8 Build 171

**E Scan - ER3DV6 probe center 10mm above Device Reference/Hearing Aid Compatibility Test (101x101x1):**

Measurement grid: dx=5mm, dy=5mm

Maximum value of peak Total field = 63.3 V/m

Probe Modulation Factor = 1.06

Reference Value = 42.6 V/m; Power Drift = 0.055 dB

**Hearing Aid Near-Field Category: M3 (AWF 0 dB)**

Peak E-field in V/m

Grid 1	Grid 2	Grid 3
<b>49.8</b>	<b>63.3</b>	<b>62.1</b>
Grid 4	Grid 5	Grid 6
<b>42.3</b>	<b>55.9</b>	<b>51.7</b>
Grid 7	Grid 8	Grid 9
<b>67.8</b>	<b>77.5</b>	<b>67.5</b>

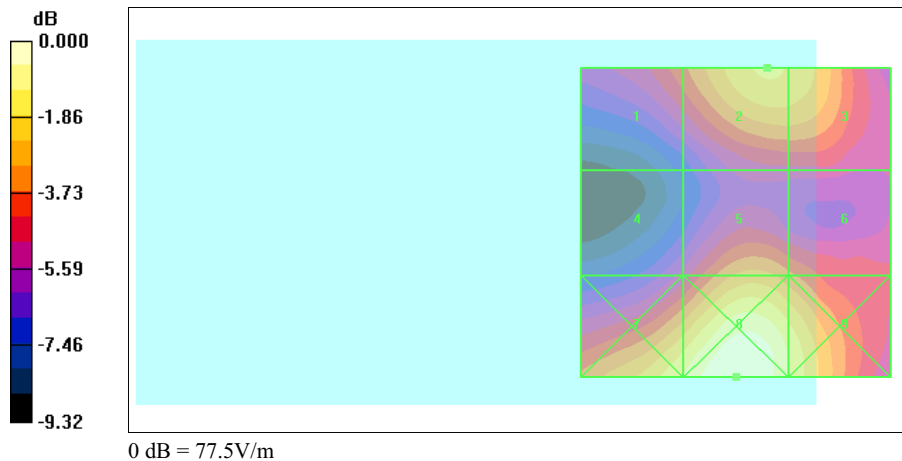



Test Laboratory: A Test Lab Techno Corp.

Date/Time: 12/13/2006 2:30:43 AM

**HAC\_CDMA PCS CH600\_802.11b CH1\_E**

**DUT: TITA100; Type:Pocket PC Phone; FCC ID:NM8TITA100**

Communication System: CDMA PCS ; Frequency: 1880 MHz;Duty Cycle: 1:1

Medium parameters used:  $\sigma = 0$  mho/m,  $\epsilon_r = 1$ ;  $\rho = 1000$  kg/m<sup>3</sup>

Phantom section: E Device Section

Measurement Standard: DASYS4 (High Precision Assessment)

DASY4 Configuration:

- Probe: ER3DV6 - SN2256; ConvF(1, 1, 1); Calibrated: 10/21/2005
- Sensor-Surface: (Fix Surface)
- Electronics: DAE3 Sn393; Calibrated: 9/5/2006
- Phantom: HAC Test Arch; Type: SD HAC P01 BA; Serial:
- Measurement SW: DASYS4, V4.7 Build 44; Postprocessing SW: SEMCAD, V1.8 Build 171

**E Scan - ER3DV6 probe center 10mm above Device Reference/Hearing Aid Compatibility Test (101x101x1):**

Measurement grid: dx=5mm, dy=5mm

Maximum value of peak Total field = 69.5 V/m

Probe Modulation Factor = 1.06

Reference Value = 47.0 V/m; Power Drift = -0.104 dB

**Hearing Aid Near-Field Category: M3 (AWF 0 dB)**

Peak E-field in V/m

Grid 1	Grid 2	Grid 3
<b>53.8</b>	<b>69.5</b>	<b>68.8</b>
Grid 4	Grid 5	Grid 6
<b>44.7</b>	<b>59.7</b>	<b>55.3</b>
Grid 7	Grid 8	Grid 9
<b>72.9</b>	<b>82.3</b>	<b>70.9</b>

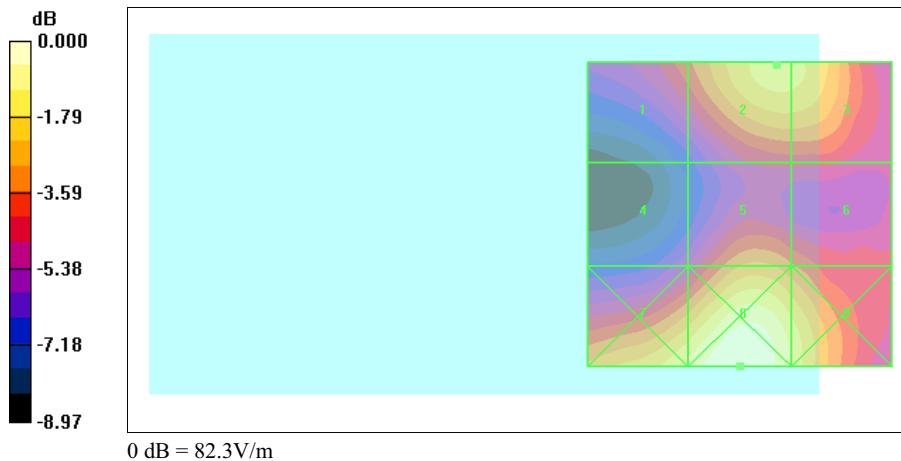



Test Laboratory: A Test Lab Techno Corp.

Date/Time: 12/13/2006 2:36:44 AM

**HAC\_CDMA PCS CH1175\_802.11b CH1\_E**

**DUT: TITA100; Type:Pocket PC Phone; FCC ID:NM8TITA100**

Communication System: CDMA PCS ; Frequency: 1908.75 MHz;Duty Cycle: 1:1

Medium parameters used:  $\sigma = 0$  mho/m,  $\epsilon_r = 1$ ;  $\rho = 1000$  kg/m<sup>3</sup>

Phantom section: E Device Section

Measurement Standard: DASYS4 (High Precision Assessment)

DASY4 Configuration:

- Probe: ER3DV6 - SN2256; ConvF(1, 1, 1); Calibrated: 10/21/2005
- Sensor-Surface: (Fix Surface)
- Electronics: DAE3 Sn393; Calibrated: 9/5/2006
- Phantom: HAC Test Arch; Type: SD HAC P01 BA; Serial:
- Measurement SW: DASYS4, V4.7 Build 44; Postprocessing SW: SEMCAD, V1.8 Build 171

**E Scan - ER3DV6 probe center 10mm above Device Reference/Hearing Aid Compatibility Test (101x101x1):**

Measurement grid: dx=5mm, dy=5mm

Maximum value of peak Total field = 70.4 V/m

Probe Modulation Factor = 1.06

Reference Value = 46.0 V/m; Power Drift = -0.121 dB

**Hearing Aid Near-Field Category: M3 (AWF 0 dB)**

Peak E-field in V/m

Grid 1	Grid 2	Grid 3
<b>54.9</b>	<b>70.4</b>	<b>69.7</b>
Grid 4	Grid 5	Grid 6
<b>42.5</b>	<b>57.2</b>	<b>53.1</b>
Grid 7	Grid 8	Grid 9
<b>70.8</b>	<b>79.9</b>	<b>68.9</b>

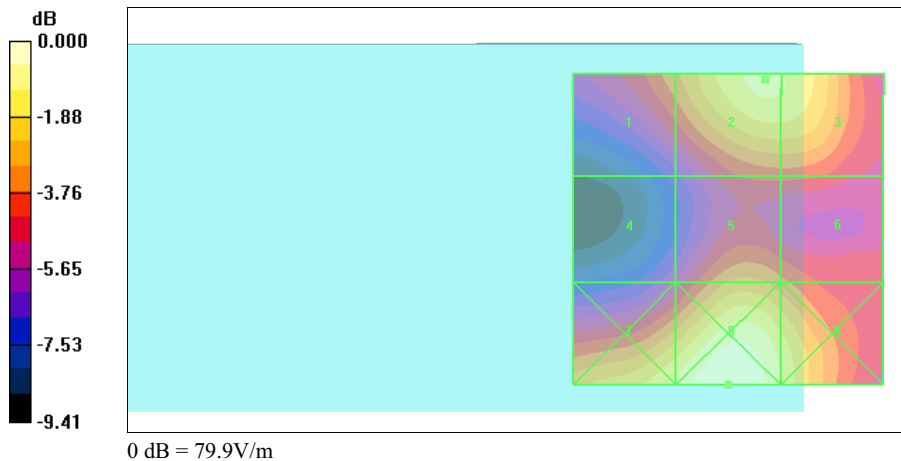



Test Laboratory: A Test Lab Techno Corp.

Date/Time: 12/13/2006 3:09:17 AM

**HAC\_CDMA Cellular CH1013\_802.11g CH1\_E**

**DUT: TITA100; Type:Pocket PC Phone; FCC ID:NM8TITA100**

Communication System: CDMA Cellular ; Frequency: 824.7 MHz;Duty Cycle: 1:1

Medium parameters used:  $\sigma = 0$  mho/m,  $\epsilon_r = 1$ ;  $\rho = 1000$  kg/m<sup>3</sup>

Phantom section: E Device Section

Measurement Standard: DASYS4 (High Precision Assessment)

DASY4 Configuration:

- Probe: ER3DV6 - SN2256; ConvF(1, 1, 1); Calibrated: 10/21/2005
- Sensor-Surface: (Fix Surface)
- Electronics: DAE3 Sn393; Calibrated: 9/5/2006
- Phantom: HAC Test Arch; Type: SD HAC P01 BA; Serial:
- Measurement SW: DASYS4, V4.7 Build 44; Postprocessing SW: SEMCAD, V1.8 Build 171

**E Scan - ER3DV6 probe center 10mm above Device Reference/Hearing Aid Compatibility Test (101x101x1):**

Measurement grid: dx=5mm, dy=5mm

Maximum value of peak Total field = 142.1 V/m

Probe Modulation Factor = 1.33

Reference Value = 91.1 V/m; Power Drift = 0.080 dB

**Hearing Aid Near-Field Category: M4 (AWF 0 dB)**

Peak E-field in V/m

Grid 1	Grid 2	Grid 3
<b>55.8</b>	<b>100.9</b>	<b>108.8</b>
Grid 4	Grid 5	Grid 6
<b>77.1</b>	<b>142.1</b>	<b>139.6</b>
Grid 7	Grid 8	Grid 9
<b>89.2</b>	<b>144.5</b>	<b>140.4</b>

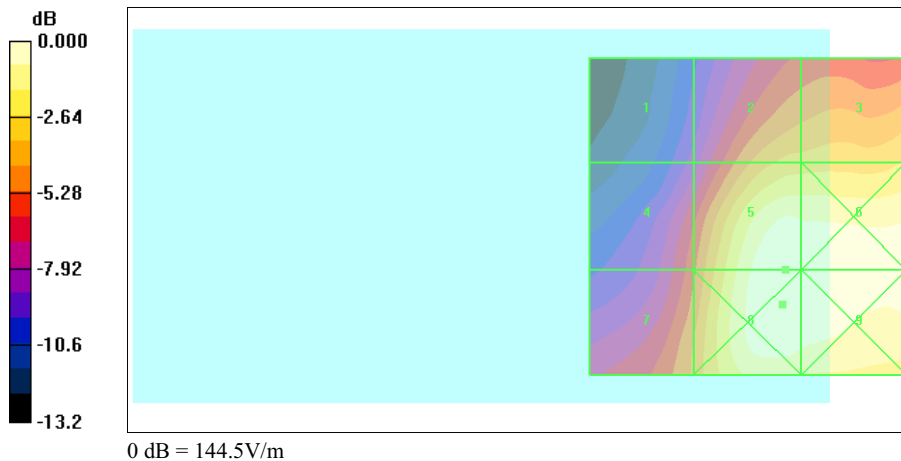



Test Laboratory: A Test Lab Techno Corp.

Date/Time: 12/13/2006 3:14:47 AM

**HAC\_CDMA Cellular CH384\_802.11g CH1\_E**

**DUT: TITA100; Type:Pocket PC Phone; FCC ID:NM8TITA100**

Communication System: CDMA Cellular ; Frequency: 836.52 MHz;Duty Cycle: 1:1

Medium parameters used:  $\sigma = 0$  mho/m,  $\epsilon_r = 1$ ;  $\rho = 1000$  kg/m<sup>3</sup>

Phantom section: E Device Section

Measurement Standard: DAS4 (High Precision Assessment)

DAS4 Configuration:

- Probe: ER3DV6 - SN2256; ConvF(1, 1, 1); Calibrated: 10/21/2005
- Sensor-Surface: (Fix Surface)
- Electronics: DAE3 Sn393; Calibrated: 9/5/2006
- Phantom: HAC Test Arch; Type: SD HAC P01 BA; Serial:
- Measurement SW: DAS4, V4.7 Build 44; Postprocessing SW: SEMCAD, V1.8 Build 171

**E Scan - ER3DV6 probe center 10mm above Device Reference/Hearing Aid Compatibility Test (101x101x1):**

Measurement grid: dx=5mm, dy=5mm

Maximum value of peak Total field = 159.5 V/m

Probe Modulation Factor = 1.33

Reference Value = 103.5 V/m; Power Drift = 0.013 dB

**Hearing Aid Near-Field Category: M4 (AWF 0 dB)**

Peak E-field in V/m

Grid 1	Grid 2	Grid 3
<b>64.8</b>	<b>113.7</b>	<b>120.0</b>
Grid 4	Grid 5	Grid 6
<b>88.1</b>	<b>159.5</b>	<b>156.7</b>
Grid 7	Grid 8	Grid 9
<b>101.3</b>	<b>162.1</b>	<b>157.6</b>

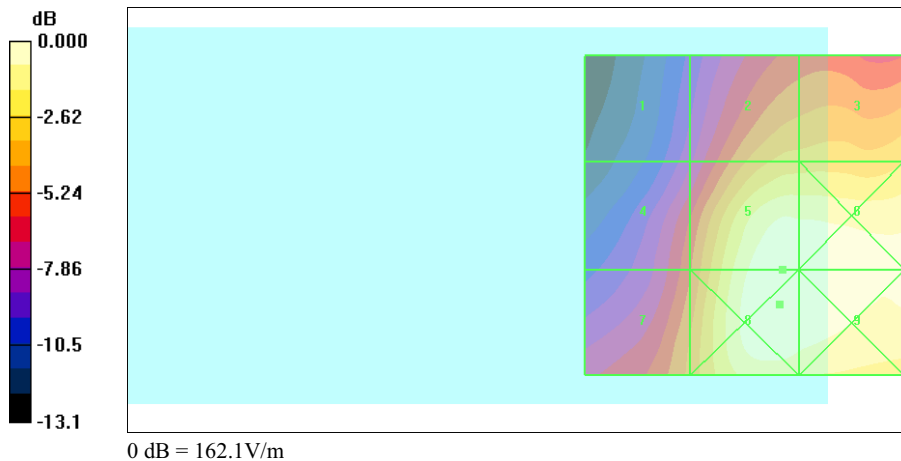



Test Laboratory: A Test Lab Techno Corp

Date/Time: 12/13/2006 4:33:26 AM

**HAC\_CDMA Cellular CH777\_802.11g CH1\_E**

**DUT:TITA100; Type:Pocket PC Phone; FCC ID:NM8TITA100**

Communication System: CDMA Cellular ; Frequency: 848.31 MHz;Duty Cycle: 1:1

Medium parameters used:  $\sigma = 0$  mho/m,  $\epsilon_r = 1$ ;  $\rho = 1000$  kg/m<sup>3</sup>

Phantom section: E Device Section

Measurement Standard: DASYS4 (High Precision Assessment)

DASY4 Configuration:

- Probe: ER3DV6 - SN2256; ConvF(1, 1, 1); Calibrated: 10/21/2005
- Sensor-Surface: (Fix Surface)
- Electronics: DAE3 Sn393; Calibrated: 9/5/2006
- Phantom: HAC Test Arch; Type: SD HAC P01 BA; Serial:
- Measurement SW: DASYS4, V4.7 Build 44; Postprocessing SW: SEMCAD, V1.8 Build 171

**E Scan - ER3DV6 probe center 10mm above Device Reference/Hearing Aid Compatibility Test (101x101x1):**

Measurement grid: dx=5mm, dy=5mm

Maximum value of peak Total field = 131.8 V/m

Probe Modulation Factor = 1.33

Reference Value = 87.2 V/m; Power Drift = 0.023 dB

**Hearing Aid Near-Field Category: M4 (AWF 0 dB)**

Peak E-field in V/m

Grid 1	Grid 2	Grid 3
<b>55.2</b>	<b>92.2</b>	<b>95.5</b>
Grid 4	Grid 5	Grid 6
<b>76.3</b>	<b>131.8</b>	<b>128.1</b>
Grid 7	Grid 8	Grid 9
<b>89.7</b>	<b>135.0</b>	<b>129.5</b>

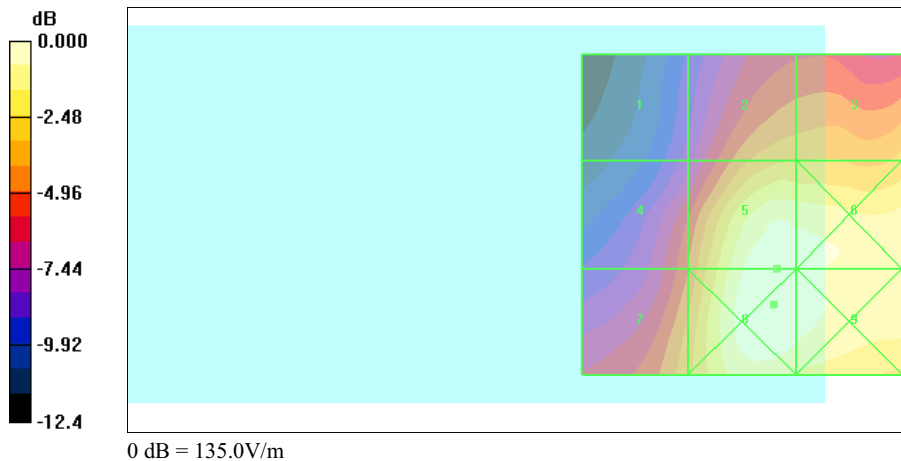





Test Laboratory: A Test Lab Techno Corp.

Date/Time: 12/13/2006 2:51:19 AM

**HAC\_CDMA PCS CH25\_802.11g CH1\_E**

**DUT: TITA100; Type:Pocket PC Phone; FCC ID:NM8TITA100**

Communication System: CDMA PCS ; Frequency: 1851.25 MHz;Duty Cycle: 1:1

Medium parameters used:  $\sigma = 0$  mho/m,  $\epsilon_r = 1$ ;  $\rho = 1000$  kg/m<sup>3</sup>

Phantom section: E Device Section

Measurement Standard: DASYS4 (High Precision Assessment)

DASY4 Configuration:

- Probe: ER3DV6 - SN2256; ConvF(1, 1, 1); Calibrated: 10/21/2005
- Sensor-Surface: (Fix Surface)
- Electronics: DAE3 Sn393; Calibrated: 9/5/2006
- Phantom: HAC Test Arch; Type: SD HAC P01 BA; Serial:
- Measurement SW: DASYS4, V4.7 Build 44; Postprocessing SW: SEMCAD, V1.8 Build 171

**E Scan - ER3DV6 probe center 10mm above Device Reference/Hearing Aid Compatibility Test (101x101x1):**

Measurement grid: dx=5mm, dy=5mm

Maximum value of peak Total field = 62.2 V/m

Probe Modulation Factor = 1.06

Reference Value = 45.9 V/m; Power Drift = -0.073 dB

**Hearing Aid Near-Field Category: M4 (AWF 0 dB)**

Peak E-field in V/m

Grid 1	Grid 2	Grid 3
<b>48.7</b>	<b>62.2</b>	<b>61.7</b>
Grid 4	Grid 5	Grid 6
<b>44.0</b>	<b>58.4</b>	<b>53.8</b>
Grid 7	Grid 8	Grid 9
<b>68.7</b>	<b>78.3</b>	<b>67.4</b>

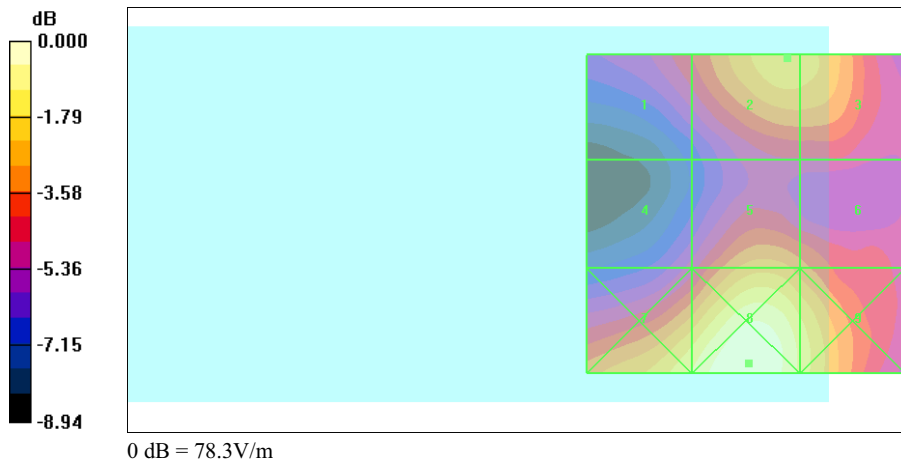



Test Laboratory: A Test Lab Techno Corp.

Date/Time: 12/13/2006 2:56:45 AM

**HAC\_CDMA PCS CH600\_802.11g CH1\_E**

**DUT: TITA100; Type:Pocket PC Phone; FCC ID:NM8TITA100**

Communication System: CDMA PCS ; Frequency: 1880 MHz;Duty Cycle: 1:1

Medium parameters used:  $\sigma = 0$  mho/m,  $\epsilon_r = 1$ ;  $\rho = 1000$  kg/m<sup>3</sup>

Phantom section: E Device Section

Measurement Standard: DASYS4 (High Precision Assessment)

DASY4 Configuration:

- Probe: ER3DV6 - SN2256; ConvF(1, 1, 1); Calibrated: 10/21/2005
- Sensor-Surface: (Fix Surface)
- Electronics: DAE3 Sn393; Calibrated: 9/5/2006
- Phantom: HAC Test Arch; Type: SD HAC P01 BA; Serial:
- Measurement SW: DASYS4, V4.7 Build 44; Postprocessing SW: SEMCAD, V1.8 Build 171

**E Scan - ER3DV6 probe center 10mm above Device Reference/Hearing Aid Compatibility Test (101x101x1):**

Measurement grid: dx=5mm, dy=5mm

Maximum value of peak Total field = 67.6 V/m

Probe Modulation Factor = 1.06

Reference Value = 47.1 V/m; Power Drift = -0.011 dB

**Hearing Aid Near-Field Category: M3 (AWF 0 dB)**

Peak E-field in V/m

Grid 1	Grid 2	Grid 3
<b>52.1</b>	<b>67.6</b>	<b>67.1</b>
Grid 4	Grid 5	Grid 6
<b>44.9</b>	<b>59.8</b>	<b>55.0</b>
Grid 7	Grid 8	Grid 9
<b>71.9</b>	<b>81.1</b>	<b>69.7</b>

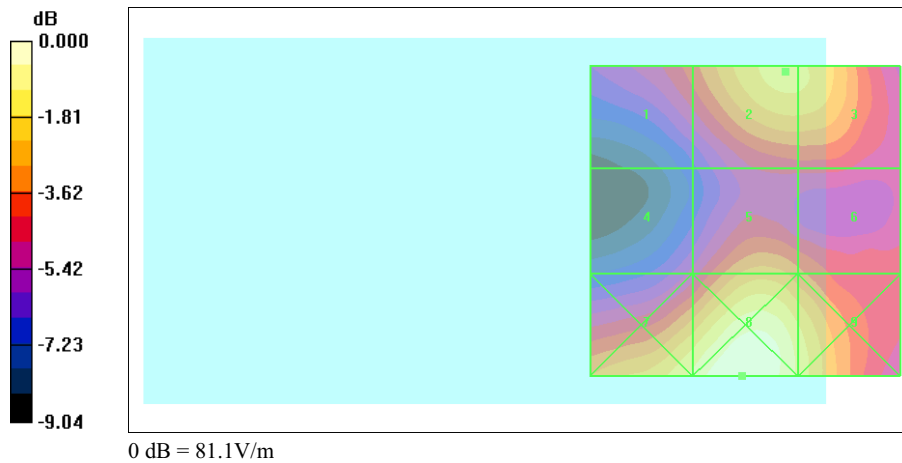



Test Laboratory: A Test Lab Techno Corp.

Date/Time: 12/13/2006 3:02:35 AM

**HAC\_CDMA PCS CH1175\_802.11g CH1\_E**

**DUT: TITA100; Type:Pocket PC Phone; FCC ID:NM8TITA100**

Communication System: CDMA PCS ; Frequency: 1908.75 MHz;Duty Cycle: 1:1

Medium parameters used:  $\sigma = 0$  mho/m,  $\epsilon_r = 1$ ;  $\rho = 1000$  kg/m<sup>3</sup>

Phantom section: E Device Section

Measurement Standard: DASYS4 (High Precision Assessment)

DASY4 Configuration:

- Probe: ER3DV6 - SN2256; ConvF(1, 1, 1); Calibrated: 10/21/2005
- Sensor-Surface: (Fix Surface)
- Electronics: DAE3 Sn393; Calibrated: 9/5/2006
- Phantom: HAC Test Arch; Type: SD HAC P01 BA; Serial:
- Measurement SW: DASYS4, V4.7 Build 44; Postprocessing SW: SEMCAD, V1.8 Build 171

**E Scan - ER3DV6 probe center 10mm above Device Reference/Hearing Aid Compatibility Test (101x101x1):**

Measurement grid: dx=5mm, dy=5mm

Maximum value of peak Total field = 67.8 V/m

Probe Modulation Factor = 1.06

Reference Value = 44.7 V/m; Power Drift = -0.198 dB

**Hearing Aid Near-Field Category: M3 (AWF 0 dB)**

Peak E-field in V/m

Grid 1	Grid 2	Grid 3
<b>52.4</b>	<b>67.8</b>	<b>67.4</b>
Grid 4	Grid 5	Grid 6
<b>42.0</b>	<b>56.0</b>	<b>52.5</b>
Grid 7	Grid 8	Grid 9
<b>69.3</b>	<b>77.8</b>	<b>67.5</b>

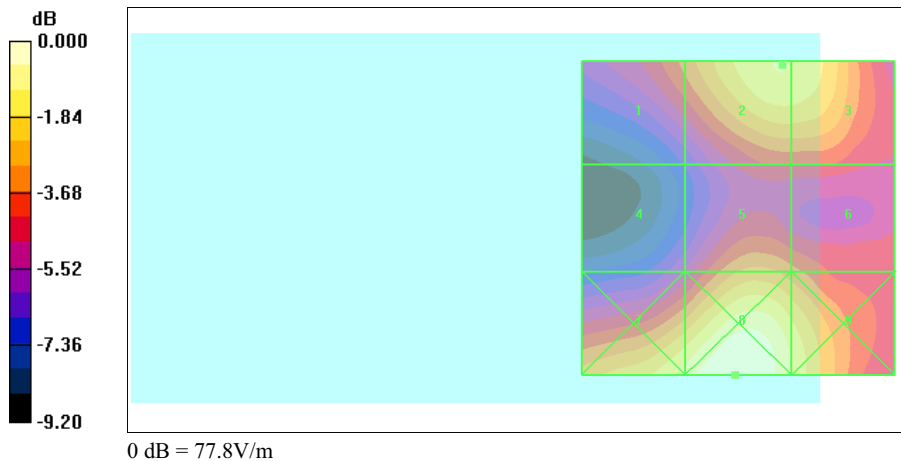



Test Laboratory: A Test Lab Techno Corp.

Date/Time: 12/19/2006 11:24:40 AM

**HAC\_CDMA Cellular CH1013\_Bluetooth CH39\_E**

**DUT: TITA100; Type:Pocket PC Phone; FCC ID:NM8TITA100**

Communication System: CDMA Cellular ; Frequency: 824.7 MHz;Duty Cycle: 1:1

Medium parameters used:  $\sigma = 0$  mho/m,  $\epsilon_r = 1$ ;  $\rho = 1000$  kg/m<sup>3</sup>

Phantom section: E Device Section

Measurement Standard: DAS4 (High Precision Assessment)

DAS4 Configuration:

- Probe: ER3DV6 - SN2256; ConvF(1, 1, 1); Calibrated: 10/21/2005
- Sensor-Surface: (Fix Surface)
- Electronics: DAE3 Sn393; Calibrated: 9/5/2006
- Phantom: HAC Test Arch; Type: SD HAC P01 BA; Serial:
- Measurement SW: DAS4, V4.7 Build 44; Postprocessing SW: SEMCAD, V1.8 Build 171

**E Scan - ER3DV6 probe center 10mm above Device Reference/Hearing Aid Compatibility Test (101x101x1):**

Measurement grid: dx=5mm, dy=5mm

Maximum value of peak Total field = 158.6 V/m

Probe Modulation Factor = 1.33

Reference Value = 109.7 V/m; Power Drift = -0.157 dB

**Hearing Aid Near-Field Category: M4 (AWF 0 dB)**

Peak E-field in V/m

Grid 1	Grid 2	Grid 3
<b>77.1</b>	<b>123.1</b>	<b>123.1</b>
Grid 4	Grid 5	Grid 6
<b>94.2</b>	<b>158.6</b>	<b>155.8</b>
Grid 7	Grid 8	Grid 9
<b>103.5</b>	<b>160.1</b>	<b>155.5</b>

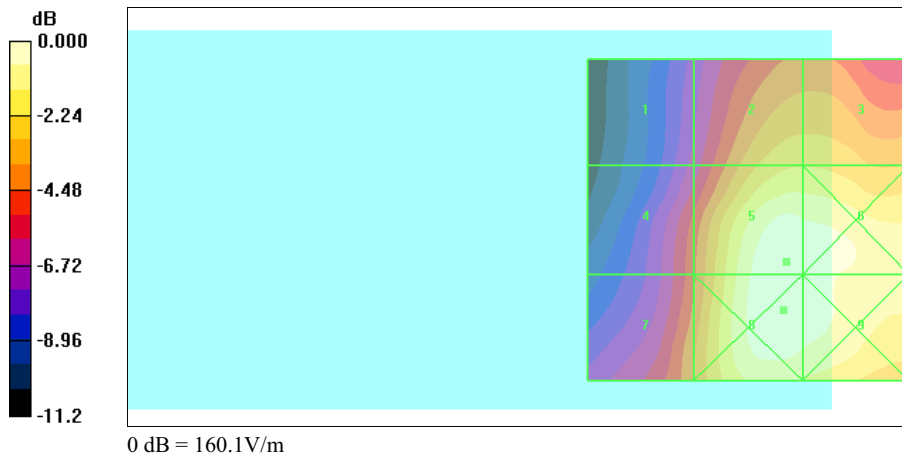



Test Laboratory: A Test Lab Techno Corp.

Date/Time: 12/19/2006 11:30:15 AM

**HAC\_CDMA Cellular CH384\_Bluetooth CH39\_E**

**DUT: TITA100; Type:Pocket PC Phone; FCC ID:NM8TITA100**

Communication System: CDMA Cellular ; Frequency: 836.52 MHz;Duty Cycle: 1:1

Medium parameters used:  $\sigma = 0$  mho/m,  $\epsilon_r = 1$ ;  $\rho = 1000$  kg/m<sup>3</sup>

Phantom section: E Device Section

Measurement Standard: DASY4 (High Precision Assessment)

DASY4 Configuration:

- Probe: ER3DV6 - SN2256; ConvF(1, 1, 1); Calibrated: 10/21/2005
- Sensor-Surface: (Fix Surface)
- Electronics: DAE3 Sn393; Calibrated: 9/5/2006
- Phantom: HAC Test Arch; Type: SD HAC P01 BA; Serial:
- Measurement SW: DASY4, V4.7 Build 44; Postprocessing SW: SEMCAD, V1.8 Build 171

**E Scan - ER3DV6 probe center 10mm above Device Reference/Hearing Aid Compatibility Test (101x101x1):**

Measurement grid: dx=5mm, dy=5mm

Maximum value of peak Total field = 171.3 V/m

Probe Modulation Factor = 1.33

Reference Value = 119.0 V/m; Power Drift = -0.071 dB

**Hearing Aid Near-Field Category: M4 (AWF 0 dB)**

Peak E-field in V/m

Grid 1	Grid 2	Grid 3
<b>84.9</b>	<b>133.5</b>	<b>133.5</b>
Grid 4	Grid 5	Grid 6
<b>102.9</b>	<b>171.3</b>	<b>168.5</b>
Grid 7	Grid 8	Grid 9
<b>113.3</b>	<b>172.5</b>	<b>168.0</b>

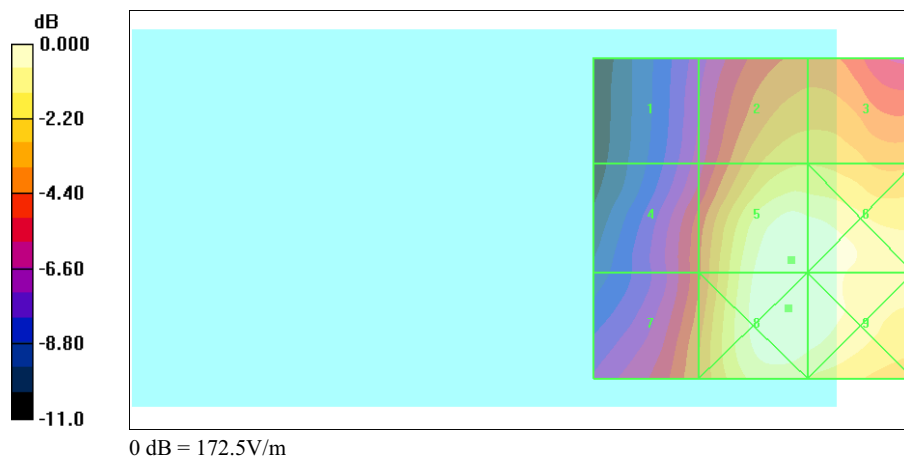



Test Laboratory: A Test Lab Techno Corp.

Date/Time: 12/19/2006 11:36:49 AM

**HAC\_CDMA Cellular CH777\_Bluetooth CH39\_E**

**DUT: TITA100; Type:Pocket PC Phone; FCC ID:NM8TITA100**

Communication System: CDMA Cellular ; Frequency: 848.31 MHz;Duty Cycle: 1:1

Medium parameters used:  $\sigma = 0$  mho/m,  $\epsilon_r = 1$ ;  $\rho = 1000$  kg/m<sup>3</sup>

Phantom section: E Device Section

Measurement Standard: DAS4 (High Precision Assessment)

DASY4 Configuration:

- Probe: ER3DV6 - SN2256; ConvF(1, 1, 1); Calibrated: 10/21/2005
- Sensor-Surface: (Fix Surface)
- Electronics: DAE3 Sn393; Calibrated: 9/5/2006
- Phantom: HAC Test Arch; Type: SD HAC P01 BA; Serial:
- Measurement SW: DAS4, V4.7 Build 44; Postprocessing SW: SEMCAD, V1.8 Build 171

**E Scan - ER3DV6 probe center 10mm above Device Reference/Hearing Aid Compatibility Test (101x101x1):**

Measurement grid: dx=5mm, dy=5mm

Maximum value of peak Total field = 144.2 V/m

Probe Modulation Factor = 1.33

Reference Value = 99.2 V/m; Power Drift = -0.009 dB

**Hearing Aid Near-Field Category: M4 (AWF 0 dB)**

Peak E-field in V/m

Grid 1	Grid 2	Grid 3
<b>73.1</b>	<b>110.8</b>	<b>110.7</b>
Grid 4	Grid 5	Grid 6
<b>88.3</b>	<b>144.2</b>	<b>140.8</b>
Grid 7	Grid 8	Grid 9
<b>97.9</b>	<b>145.0</b>	<b>140.1</b>

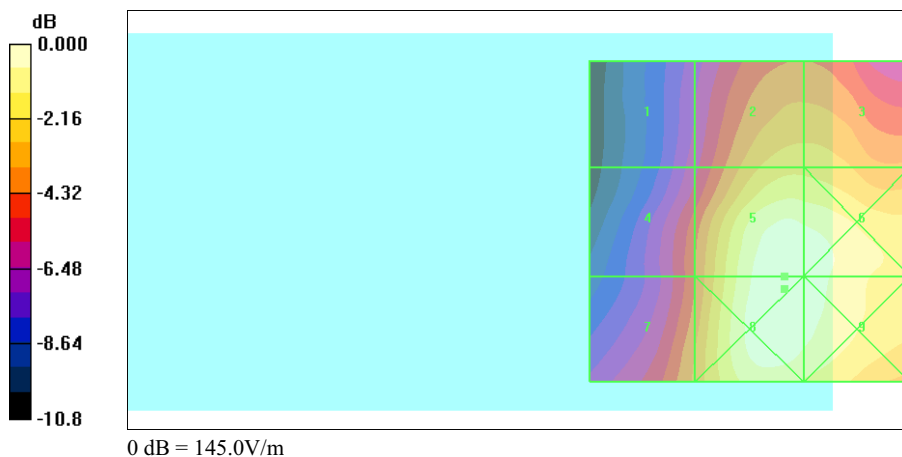



Test Laboratory: A Test Lab Techno Corp.

Date/Time: 12/19/2006 10:55:28 AM

**HAC\_CDMA PCS CH25\_Bluetooth CH39\_E**

**DUT: TITA100; Type:Pocket PC Phone; FCC ID:NM8TITA100**

Communication System: CDMA PCS ; Frequency: 1851.25 MHz;Duty Cycle: 1:1

Medium parameters used:  $\sigma = 0$  mho/m,  $\epsilon_r = 1$ ;  $\rho = 1000$  kg/m<sup>3</sup>

Phantom section: E Device Section

Measurement Standard: DAS4 (High Precision Assessment)

DASY4 Configuration:

- Probe: ER3DV6 - SN2256; ConvF(1, 1, 1); Calibrated: 10/21/2005
- Sensor-Surface: (Fix Surface)
- Electronics: DAE3 Sn393; Calibrated: 9/5/2006
- Phantom: HAC Test Arch; Type: SD HAC P01 BA; Serial:
- Measurement SW: DAS4, V4.7 Build 44; Postprocessing SW: SEMCAD, V1.8 Build 171

**E Scan - ER3DV6 probe center 10mm above Device Reference/Hearing Aid Compatibility Test (101x101x1):**

Measurement grid: dx=5mm, dy=5mm

Maximum value of peak Total field = 63.4 V/m

Probe Modulation Factor = 1.06

Reference Value = 44.4 V/m; Power Drift = -0.056 dB

**Hearing Aid Near-Field Category: M3 (AWF 0 dB)**

Peak E-field in V/m

Grid 1	Grid 2	Grid 3
<b>47.2</b>	<b>63.4</b>	<b>63.0</b>
Grid 4	Grid 5	Grid 6
<b>43.5</b>	<b>59.6</b>	<b>55.0</b>
Grid 7	Grid 8	Grid 9
<b>73.4</b>	<b>83.3</b>	<b>71.5</b>

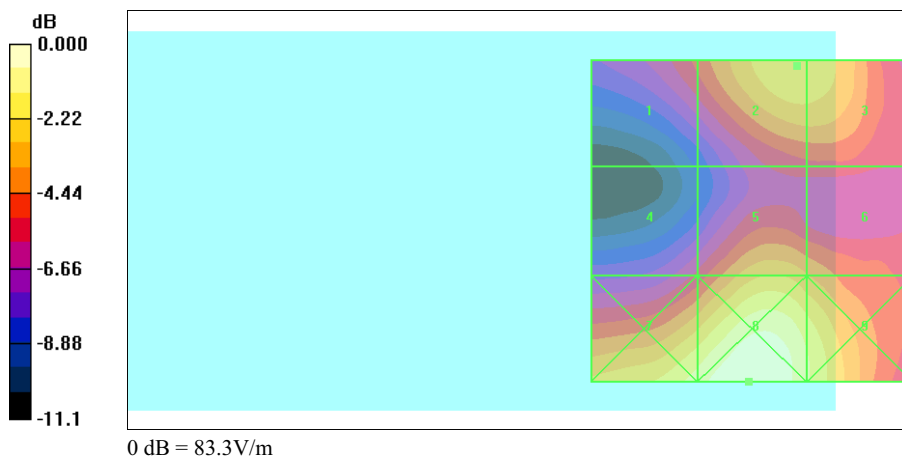



Test Laboratory: A Test Lab Techno Corp.

Date/Time: 12/19/2006 11:02:07 AM

**HAC\_CDMA PCS CH600\_Bluetooth CH39\_E**

**DUT: TITA100; Type:Pocket PC Phone; FCC ID:NM8TITA100**

Communication System: CDMA PCS ; Frequency: 1880 MHz;Duty Cycle: 1:1

Medium parameters used:  $\sigma = 0$  mho/m,  $\epsilon_r = 1$ ;  $\rho = 1000$  kg/m<sup>3</sup>

Phantom section: E Device Section

Measurement Standard: DASYS4 (High Precision Assessment)

DASY4 Configuration:

- Probe: ER3DV6 - SN2256; ConvF(1, 1, 1); Calibrated: 10/21/2005
- Sensor-Surface: (Fix Surface)
- Electronics: DAE3 Sn393; Calibrated: 9/5/2006
- Phantom: HAC Test Arch; Type: SD HAC P01 BA; Serial:
- Measurement SW: DASYS4, V4.7 Build 44; Postprocessing SW: SEMCAD, V1.8 Build 171

**E Scan - ER3DV6 probe center 10mm above Device Reference/Hearing Aid Compatibility Test (101x101x1):**

Measurement grid: dx=5mm, dy=5mm

Maximum value of peak Total field = 70.0 V/m

Probe Modulation Factor = 1.06

Reference Value = 45.7 V/m; Power Drift = 0.009 dB

**Hearing Aid Near-Field Category: M3 (AWF 0 dB)**

Peak E-field in V/m

Grid 1	Grid 2	Grid 3
<b>53.1</b>	<b>70.0</b>	<b>69.3</b>
Grid 4	Grid 5	Grid 6
<b>43.9</b>	<b>60.4</b>	<b>56.3</b>
Grid 7	Grid 8	Grid 9
<b>76.0</b>	<b>86.5</b>	<b>74.6</b>

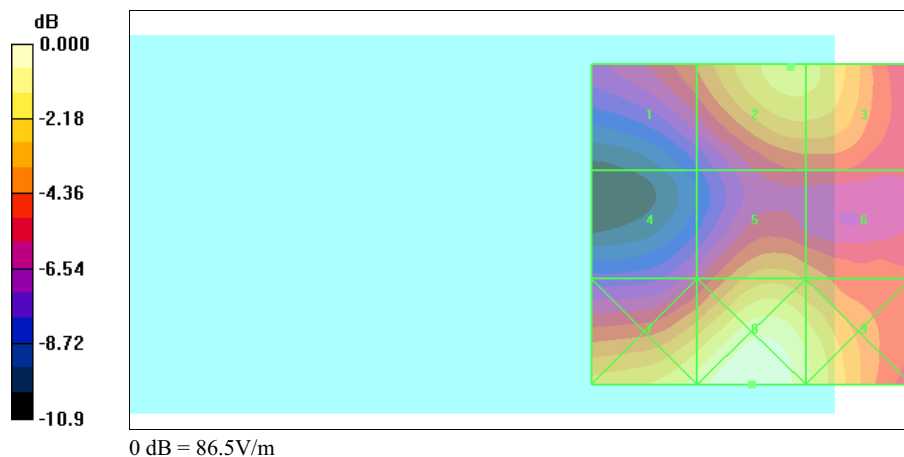





Test Laboratory: A Test Lab Techno Corp.

Date/Time: 12/19/2006 11:09:07 AM

**HAC\_CDMA PCS CH1175\_Bluetooth CH39\_E**

**DUT: TITA100; Type:Pocket PC Phone; FCC ID:NM8TITA100**

Communication System: CDMA PCS ; Frequency: 1908.75 MHz;Duty Cycle: 1:1

Medium parameters used:  $\sigma = 0$  mho/m,  $\epsilon_r = 1$ ;  $\rho = 1000$  kg/m<sup>3</sup>

Phantom section: E Device Section

Measurement Standard: DAS4 (High Precision Assessment)

DAS4 Configuration:

- Probe: ER3DV6 - SN2256; ConvF(1, 1, 1); Calibrated: 10/21/2005
- Sensor-Surface: (Fix Surface)
- Electronics: DAE3 Sn393; Calibrated: 9/5/2006
- Phantom: HAC Test Arch; Type: SD HAC P01 BA; Serial:
- Measurement SW: DAS4, V4.7 Build 44; Postprocessing SW: SEMCAD, V1.8 Build 171

**E Scan - ER3DV6 probe center 10mm above Device Reference/Hearing Aid Compatibility Test (101x101x1):**

Measurement grid: dx=5mm, dy=5mm

Maximum value of peak Total field = 70.4 V/m

Probe Modulation Factor = 1.06

Reference Value = 44.1 V/m; Power Drift = -0.058 dB

**Hearing Aid Near-Field Category: M3 (AWF 0 dB)**

Peak E-field in V/m

Grid 1	Grid 2	Grid 3
<b>54.2</b>	<b>70.4</b>	<b>69.8</b>
Grid 4	Grid 5	Grid 6
<b>41.6</b>	<b>57.8</b>	<b>54.0</b>
Grid 7	Grid 8	Grid 9
<b>73.4</b>	<b>82.4</b>	<b>72.1</b>

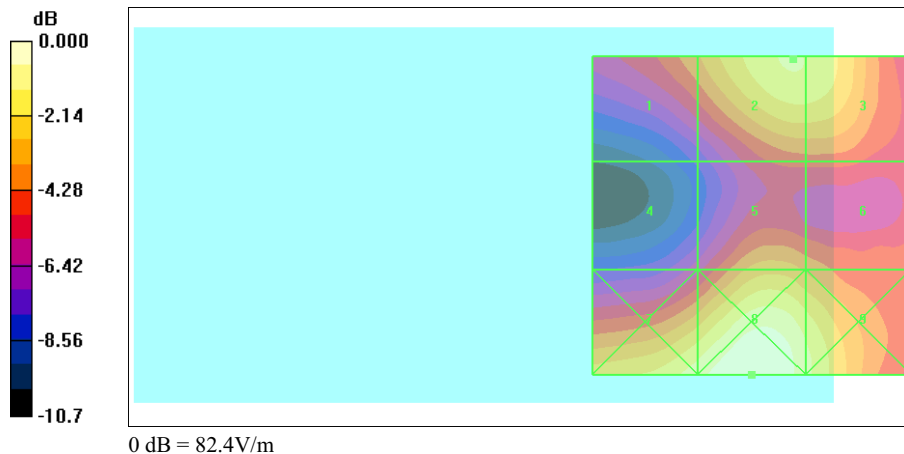



A Test Lab Techno Corp.

Date/Time: 10/9/2006 10:01:17 PM

**802.11b CH1\_E**

**DUT: TTTA100; Type:Pocket PC Phone; FCC ID:NM8TTTA100**

Communication System: IEEE 802.11b; Frequency: 2412 MHz;Duty Cycle: 1:1

Medium parameters used:  $\sigma = 0$  mho/m,  $\epsilon_r = 1$ ;  $\rho = 1000$  kg/m<sup>3</sup>

Phantom section: E Device Section

Measurement Standard: DAS4 (High Precision Assessment)

DASY4 Configuration:

- Probe: ER3DV6 - SN2256; ConvF(1, 1, 1); Calibrated: 10/21/2005
- Sensor-Surface: (Fix Surface)
- Electronics: DAE3 Sn393; Calibrated: 9/5/2006
- Phantom: HAC Test Arch; Type: SD HAC P01 BA; Serial:
- Measurement SW: DAS4, V4.7 Build 44; Postprocessing SW: SEMCAD, V1.8 Build 171

**E Scan - ER3DV6 probe center 10mm above Device Reference/Hearing Aid Compatibility Test (101x101x1):**

Measurement grid: dx=5mm, dy=5mm

Maximum value of peak Total field = 19.3 V/m

Probe Modulation Factor = 0.880

Reference Value = 15.3 V/m; Power Drift = -0.150 dB

**Hearing Aid Near-Field Category: M4 (AWF 0 dB)**

Peak E-field in V/m

Grid 1	Grid 2	Grid 3
<b>20.3</b>	<b>22.7</b>	<b>18.4</b>
Grid 4	Grid 5	Grid 6
<b>15.1</b>	<b>17.1</b>	<b>14.2</b>
Grid 7	Grid 8	Grid 9
<b>16.8</b>	<b>19.3</b>	<b>16.1</b>

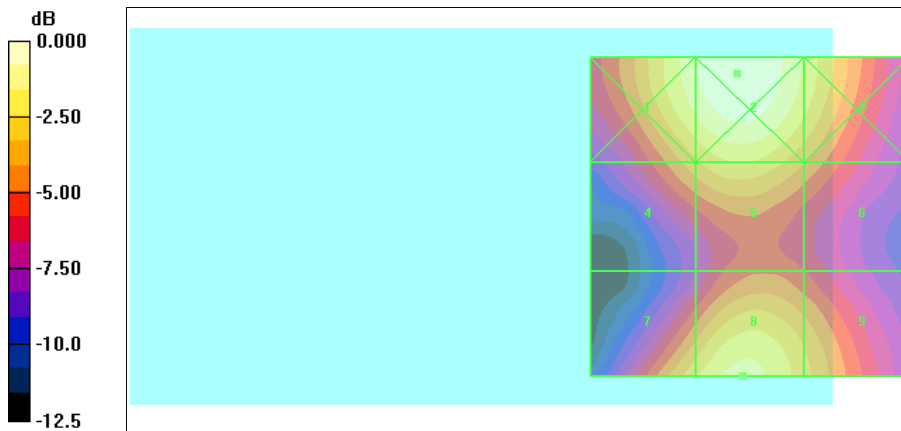

0 dB = 22.7V/m



A Test Lab Techno Corp.

Date/Time: 10/9/2006 10:15:14 PM

**802.11b CH6\_E**

**DUT: TTTA100; Type:Pocket PC Phone; FCC ID:NM8TITA100**

Communication System: IEEE 802.11b; Frequency: 2437 MHz;Duty Cycle: 1:1

Medium parameters used:  $\sigma = 0$  mho/m,  $\epsilon_r = 1$ ;  $\rho = 1000$  kg/m<sup>3</sup>

Phantom section: E Device Section

Measurement Standard: DASYS4 (High Precision Assessment)

DASY4 Configuration:

- Probe: ER3DV6 - SN2256; ConvF(1, 1, 1); Calibrated: 10/21/2005
- Sensor-Surface: (Fix Surface)
- Electronics: DAE3 Sn393; Calibrated: 9/5/2006
- Phantom: HAC Test Arch; Type: SD HAC P01 BA; Serial:
- Measurement SW: DASY4, V4.7 Build 44; Postprocessing SW: SEMCAD, V1.8 Build 171

**E Scan - ER3DV6 probe center 10mm above Device Reference/Hearing Aid Compatibility Test (101x101x1):**

Measurement grid: dx=5mm, dy=5mm

Maximum value of peak Total field = 17.2 V/m

Probe Modulation Factor = 0.880

Reference Value = 13.2 V/m; Power Drift = -0.082 dB

**Hearing Aid Near-Field Category: M4 (AWF 0 dB)**

Peak E-field in V/m

Grid 1	Grid 2	Grid 3
<b>20.0</b>	<b>20.5</b>	<b>13.8</b>
Grid 4	Grid 5	Grid 6
<b>15.3</b>	<b>15.7</b>	<b>10.9</b>
Grid 7	Grid 8	Grid 9
<b>17.1</b>	<b>17.2</b>	<b>11.8</b>

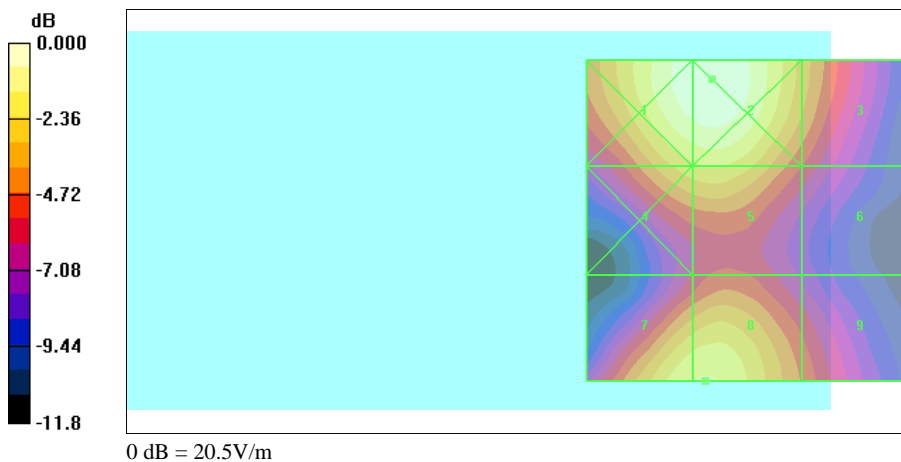



A Test Lab Techno Corp.

Date/Time: 10/9/2006 10:27:36 PM

**802.11b CH11\_E**

**DUT: TTTA100; Type:Pocket PC Phone; FCC ID:NM8TITA100**

Communication System: IEEE 802.11b; Frequency: 2462 MHz;Duty Cycle: 1:1

Medium parameters used:  $\sigma = 0$  mho/m,  $\epsilon_r = 1$ ;  $\rho = 1000$  kg/m<sup>3</sup>

Phantom section: E Device Section

Measurement Standard: DASYS4 (High Precision Assessment)

DASY4 Configuration:

- Probe: ER3DV6 - SN2256; ConvF(1, 1, 1); Calibrated: 10/21/2005
- Sensor-Surface: (Fix Surface)
- Electronics: DAE3 Sn393; Calibrated: 9/5/2006
- Phantom: HAC Test Arch; Type: SD HAC P01 BA; Serial:
- Measurement SW: DASYS4, V4.7 Build 44; Postprocessing SW: SEMCAD, V1.8 Build 171

**E Scan - ER3DV6 probe center 10mm above Device Reference/Hearing Aid Compatibility Test (101x101x1):**

Measurement grid: dx=5mm, dy=5mm

Maximum value of peak Total field = 16.7 V/m

Probe Modulation Factor = 0.880

Reference Value = 12.6 V/m; Power Drift = 0.169 dB

**Hearing Aid Near-Field Category: M4 (AWF 0 dB)**

Peak E-field in V/m

Grid 1	Grid 2	Grid 3
<b>16.1</b>	<b>17.3</b>	<b>13.6</b>
Grid 4	Grid 5	Grid 6
<b>12.1</b>	<b>13.5</b>	<b>11.1</b>
Grid 7	Grid 8	Grid 9
<b>14.9</b>	<b>16.7</b>	<b>13.3</b>

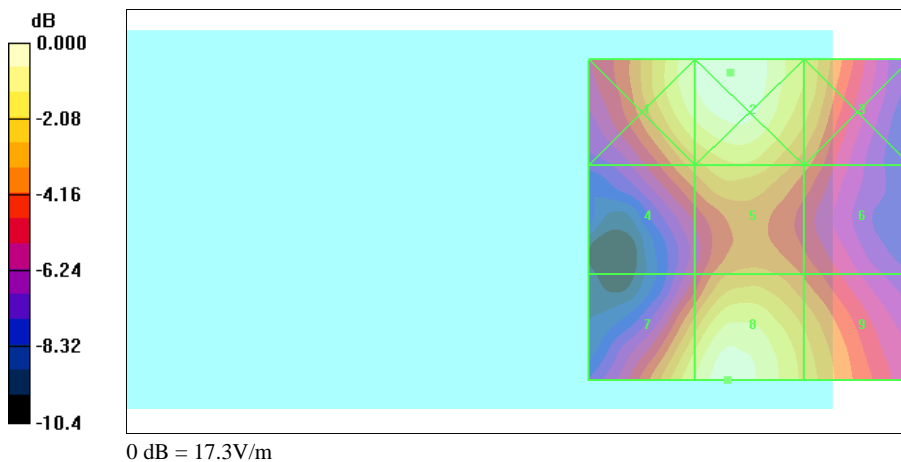



A Test Lab Techno Corp.

Date/Time: 10/9/2006 10:38:34 PM

**802.11g CH1\_E**

**DUT: TTTA100; Type:Pocket PC Phone; FCC ID:NM8TITA100**

Communication System: IEEE 802.11g; Frequency: 2412 MHz;Duty Cycle: 1:1

Medium parameters used:  $\sigma = 0$  mho/m,  $\epsilon_r = 1$ ;  $\rho = 1000$  kg/m<sup>3</sup>

Phantom section: E Device Section

Measurement Standard: DASYS4 (High Precision Assessment)

DASY4 Configuration:

- Probe: ER3DV6 - SN2256; ConvF(1, 1, 1); Calibrated: 10/21/2005
- Sensor-Surface: (Fix Surface)
- Electronics: DAE3 Sn393; Calibrated: 9/5/2006
- Phantom: HAC Test Arch; Type: SD HAC P01 BA; Serial:
- Measurement SW: DASYS4, V4.7 Build 44; Postprocessing SW: SEMCAD, V1.8 Build 171

**E Scan - ER3DV6 probe center 10mm above Device Reference/Hearing Aid Compatibility Test (101x101x1):**

Measurement grid: dx=5mm, dy=5mm

Maximum value of peak Total field = 12.9 V/m

Probe Modulation Factor = 0.650

Reference Value = 14.0 V/m; Power Drift = -0.115 dB

**Hearing Aid Near-Field Category: M4 (AWF 0 dB)**

Peak E-field in V/m

Grid 1	Grid 2	Grid 3
<b>13.9</b>	<b>15.0</b>	<b>11.6</b>
Grid 4	Grid 5	Grid 6
<b>10.2</b>	<b>11.0</b>	<b>8.82</b>
Grid 7	Grid 8	Grid 9
<b>12.0</b>	<b>12.9</b>	<b>10.0</b>

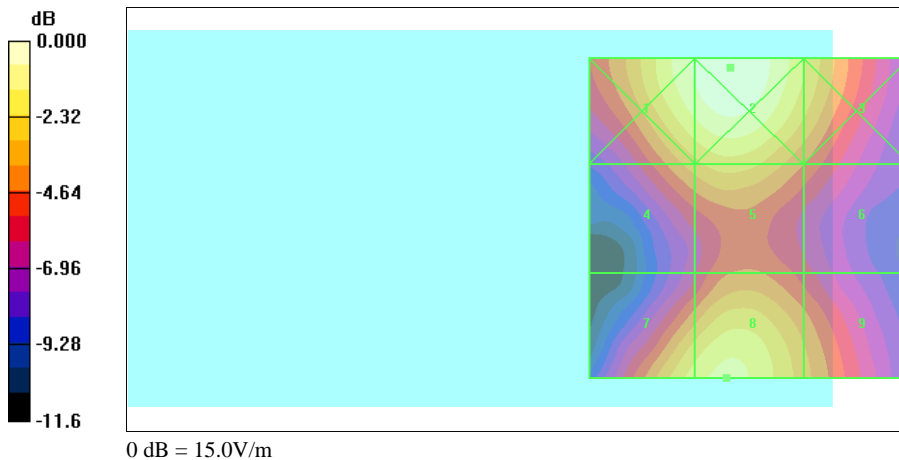



A Test Lab Techno Corp.

Date/Time: 10/9/2006 10:52:21 PM

**802.11g CH6\_E**

**DUT: TTTA100; Type: Pocket PC Phone; FCC ID: NM8TITA100**

Communication System: IEEE 802.11g; Frequency: 2437 MHz; Duty Cycle: 1:1

Medium parameters used:  $\sigma = 0$  mho/m,  $\epsilon_r = 1$ ;  $\rho = 1000$  kg/m<sup>3</sup>

Phantom section: E Device Section

Measurement Standard: DASYS4 (High Precision Assessment)

DASY4 Configuration:

- Probe: ER3DV6 - SN2256; ConvF(1, 1, 1); Calibrated: 10/21/2005
- Sensor-Surface: (Fix Surface)
- Electronics: DAE3 Sn393; Calibrated: 9/5/2006
- Phantom: HAC Test Arch; Type: SD HAC P01 BA; Serial:
- Measurement SW: DASYS4, V4.7 Build 44; Postprocessing SW: SEMCAD, V1.8 Build 171

**E Scan - ER3DV6 probe center 10mm above Device Reference/Hearing Aid Compatibility Test (101x101x1):**

Measurement grid: dx=5mm, dy=5mm

Maximum value of peak Total field = 13.1 V/m

Probe Modulation Factor = 0.650

Reference Value = 12.7 V/m; Power Drift = 0.050 dB

**Hearing Aid Near-Field Category: M4 (AWF 0 dB)**

Peak E-field in V/m

Grid 1	Grid 2	Grid 3
<b>13.3</b>	<b>14.7</b>	<b>11.8</b>
Grid 4	Grid 5	Grid 6
<b>9.16</b>	<b>10.2</b>	<b>8.53</b>
Grid 7	Grid 8	Grid 9
<b>11.9</b>	<b>13.1</b>	<b>10.6</b>

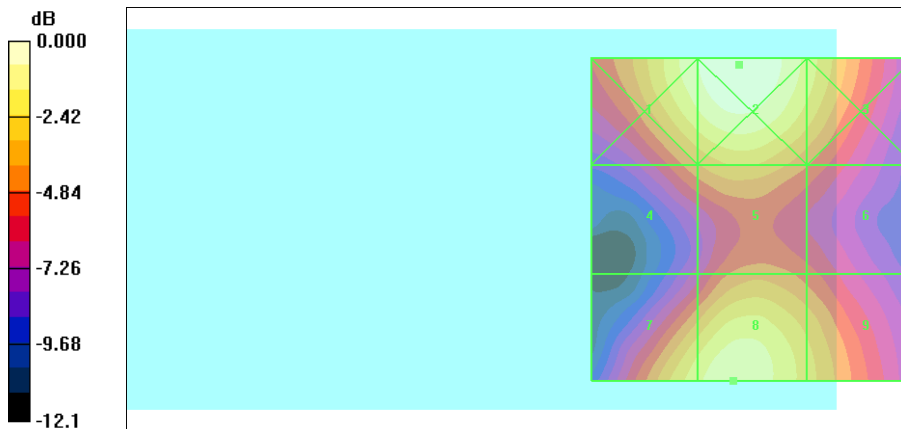

0 dB = 14.7V/m



A Test Lab Techno Corp.

Date/Time: 10/9/2006 11:04:00 PM

**802.11g CH11\_E**

**DUT:TTTA100; Type:Pocket PC Phone; FCC ID:NM8TITA100**

Communication System: IEEE 802.11g; Frequency: 2462 MHz;Duty Cycle: 1:1

Medium parameters used:  $\sigma = 0$  mho/m,  $\epsilon_r = 1$ ;  $\rho = 1000$  kg/m<sup>3</sup>

Phantom section: E Device Section

Measurement Standard: DAS4 (High Precision Assessment)

DASY4 Configuration:

- Probe: ER3DV6 - SN2256; ConvF(1, 1, 1); Calibrated: 10/21/2005
- Sensor-Surface: (Fix Surface)
- Electronics: DAE3 Sn393; Calibrated: 9/5/2006
- Phantom: HAC Test Arch; Type: SD HAC P01 BA; Serial:
- Measurement SW: DAS4, V4.7 Build 44; Postprocessing SW: SEMCAD, V1.8 Build 171

**E Scan - ER3DV6 probe center 10mm above Device Reference/Hearing Aid Compatibility Test (101x101x1):**

Measurement grid: dx=5mm, dy=5mm

Maximum value of peak Total field = 12.8 V/m

Probe Modulation Factor = 0.650

Reference Value = 13.2 V/m; Power Drift = -0.175 dB

**Hearing Aid Near-Field Category: M4 (AWF 0 dB)**

Peak E-field in V/m

Grid 1	Grid 2	Grid 3
<b>13.4</b>	<b>14.8</b>	<b>11.5</b>
Grid 4	Grid 5	Grid 6
<b>9.52</b>	<b>10.7</b>	<b>8.70</b>
Grid 7	Grid 8	Grid 9
<b>11.8</b>	<b>12.8</b>	<b>10.2</b>

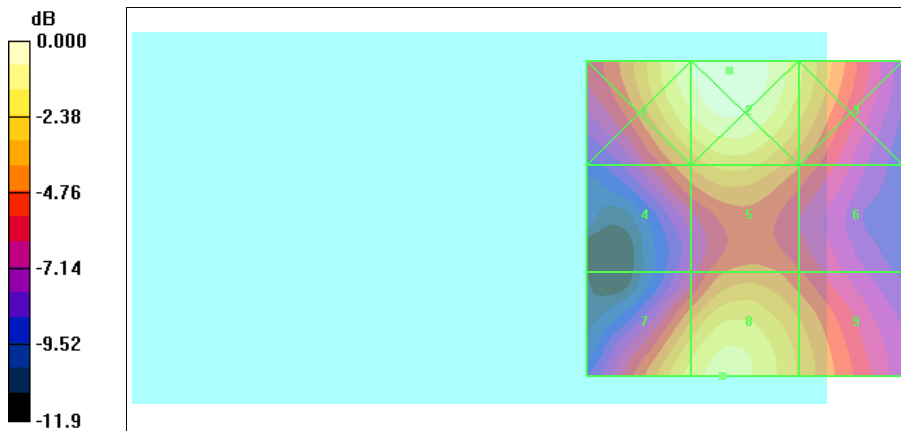



A Test Lab Techno Corp.

Date/Time: 10/9/2006 6:37:46 PM

**CDMA 850 CH1013\_H**

**DUT: TITA100; Type:Pocket PC Phone; FCC ID:NM8TITA100**

Communication System: CDMA; Frequency: 824.7 MHz; Duty Cycle: 1:1

Medium parameters used:  $\sigma = 0$  mho/m,  $\epsilon_r = 1$ ;  $\rho = 1$  kg/m<sup>3</sup>

Phantom section: E Device Section

Measurement Standard: DAS4 (High Precision Assessment)

DASY4 Configuration:

- Probe: H3DV6 - SN6076; ; Calibrated: 10/21/2005
- Sensor-Surface: (Fix Surface)
- Electronics: DAE3 Sn393; Calibrated: 9/5/2006
- Phantom: HAC Test Arch; Type: SD HAC P01 BA
- Measurement SW: DASY4, V4.7 Build 44; Postprocessing SW: SEMCAD, V1.8 Build 171

**H Scan - H3DV6 probe center 10mm above Device Reference/Hearing Aid Compatibility Test (101x101x1):**

Measurement grid: dx=5mm, dy=5mm

Maximum value of peak Total field = 0.323 A/m

Probe Modulation Factor = 1.25

Reference Value = 0.163 A/m; Power Drift = 0.030 dB

**Hearing Aid Near-Field Category: M4 (AWF 0 dB)**

Peak H-field in A/m

Grid 1	Grid 2	Grid 3
<b>0.352</b>	<b>0.366</b>	<b>0.340</b>
Grid 4	Grid 5	Grid 6
<b>0.323</b>	<b>0.323</b>	<b>0.306</b>
Grid 7	Grid 8	Grid 9
<b>0.250</b>	<b>0.244</b>	<b>0.214</b>

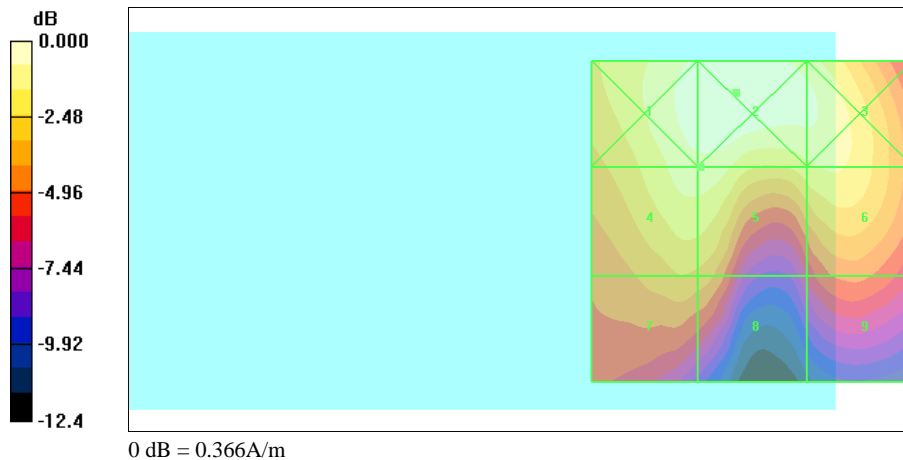





A Test Lab Techno Corp.

Date/Time: 10/9/2006 6:44:56 PM

**CDMA 850 CH384\_H**

**DUT: TITA100; Type:Pocket PC Phone; FCC ID:NM8TITA100**

Communication System: CDMA; Frequency: 836.52 MHz;Duty Cycle: 1:1

Medium parameters used:  $\sigma = 0$  mho/m,  $\epsilon_r = 1$ ;  $\rho = 1$  kg/m<sup>3</sup>

Phantom section: E Device Section

Measurement Standard: DASYS4 (High Precision Assessment)

DASY4 Configuration:

- Probe: H3DV6 - SN6076; ; Calibrated: 10/21/2005
- Sensor-Surface: (Fix Surface)
- Electronics: DAE3 Sn393; Calibrated: 9/5/2006
- Phantom: HAC Test Arch; Type: SD HAC P01 BA
- Measurement SW: DASYS4, V4.7 Build 44; Postprocessing SW: SEMCAD, V1.8 Build 171

**H Scan - H3DV6 probe center 10mm above Device Reference/Hearing Aid Compatibility Test (101x101x1):**

Measurement grid: dx=5mm, dy=5mm

Maximum value of peak Total field = 0.366 A/m

Probe Modulation Factor = 1.25

Reference Value = 0.189 A/m; Power Drift = -0.081 dB

**Hearing Aid Near-Field Category: M4 (AWF 0 dB)**

Peak H-field in A/m

Grid 1	Grid 2	Grid 3
<b>0.397</b>	<b>0.412</b>	<b>0.385</b>
Grid 4	Grid 5	Grid 6
<b>0.366</b>	<b>0.366</b>	<b>0.345</b>
Grid 7	Grid 8	Grid 9
<b>0.285</b>	<b>0.277</b>	<b>0.242</b>

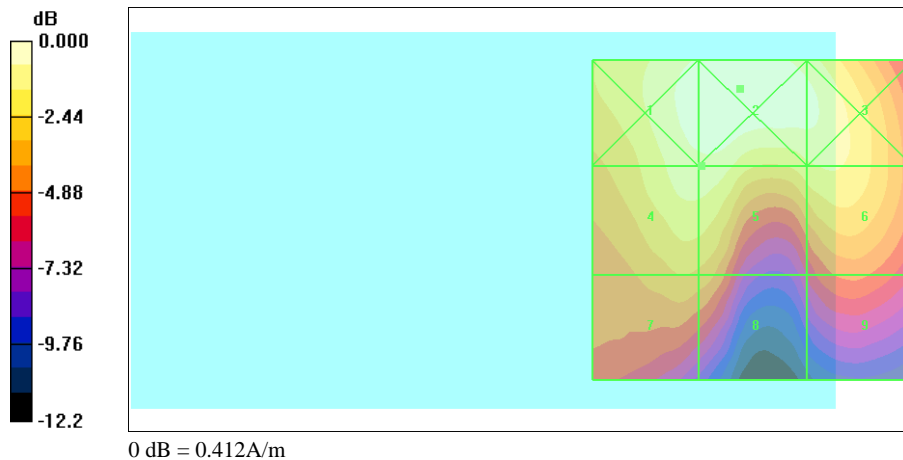



A Test Lab Techno Corp.

Date/Time: 10/9/2006 6:50:44 PM

**CDMA 850 CH777\_H**

**DUT: TITA100; Type:Pocket PC Phone; FCC ID:NM8TITA100**

Communication System: CDMA; Frequency: 848.31 MHz;Duty Cycle: 1:1

Medium parameters used:  $\sigma = 0$  mho/m,  $\epsilon_r = 1$ ;  $\rho = 1$  kg/m<sup>3</sup>

Phantom section: E Device Section

Measurement Standard: DAS4 (High Precision Assessment)

DASY4 Configuration:

- Probe: H3DV6 - SN6076; ; Calibrated: 10/21/2005
- Sensor-Surface: (Fix Surface)
- Electronics: DAE3 Sn393; Calibrated: 9/5/2006
- Phantom: HAC Test Arch; Type: SD HAC P01 BA
- Measurement SW: DASY4, V4.7 Build 44; Postprocessing SW: SEMCAD, V1.8 Build 171

**H Scan - H3DV6 probe center 10mm above Device Reference/Hearing Aid Compatibility Test (101x101x1):**

Measurement grid: dx=5mm, dy=5mm

Maximum value of peak Total field = 0.323 A/m

Probe Modulation Factor = 1.25

Reference Value = 0.165 A/m; Power Drift = 0.016 dB

**Hearing Aid Near-Field Category: M4 (AWF 0 dB)**

Peak H-field in A/m

Grid 1	Grid 2	Grid 3
<b>0.346</b>	<b>0.359</b>	<b>0.336</b>
Grid 4	Grid 5	Grid 6
<b>0.323</b>	<b>0.323</b>	<b>0.303</b>
Grid 7	Grid 8	Grid 9
<b>0.252</b>	<b>0.246</b>	<b>0.213</b>

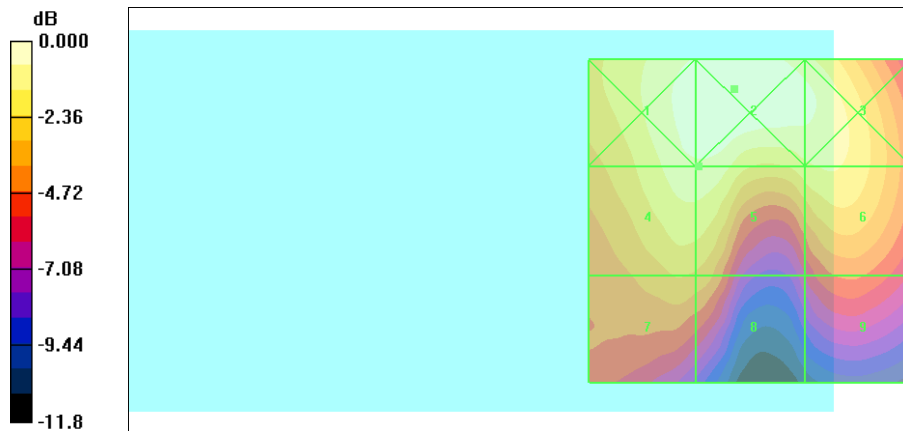

0 dB = 0.359A/m



A Test Lab Techno Corp.

Date/Time: 10/9/2006 6:14:11 PM

**CDMA 1900 CH25\_H**

**DUT: TITA100; Type:Pocket PC Phone; FCC ID:NM8TITA100**

Communication System: PCS 1900; Frequency: 1851.25 MHz;Duty Cycle: 1:1

Medium parameters used:  $\sigma = 0$  mho/m,  $\epsilon_r = 1$ ;  $\rho = 1$  kg/m<sup>3</sup>

Phantom section: E Device Section

Measurement Standard: DAS4 (High Precision Assessment)

DASY4 Configuration:

- Probe: H3DV6 - SN6076; ; Calibrated: 10/21/2005
- Sensor-Surface: (Fix Surface)
- Electronics: DAE3 Sn393; Calibrated: 9/5/2006
- Phantom: HAC Test Arch; Type: SD HAC P01 BA
- Measurement SW: DASY4, V4.7 Build 44; Postprocessing SW: SEMCAD, V1.8 Build 171

**H Scan - H3DV6 probe center 10mm above Device Reference/Hearing Aid Compatibility Test (101x101x1):**

Measurement grid: dx=5mm, dy=5mm

Maximum value of peak Total field = 0.266 A/m

Probe Modulation Factor = 1.08

Reference Value = 0.195 A/m; Power Drift = -0.031 dB

**Hearing Aid Near-Field Category: M3 (AWF 0 dB)**

Peak H-field in A/m

Grid 1	Grid 2	Grid 3
<b>0.264</b>	<b>0.266</b>	<b>0.215</b>
Grid 4	Grid 5	Grid 6
<b>0.265</b>	<b>0.266</b>	<b>0.184</b>
Grid 7	Grid 8	Grid 9
<b>0.228</b>	<b>0.229</b>	<b>0.125</b>

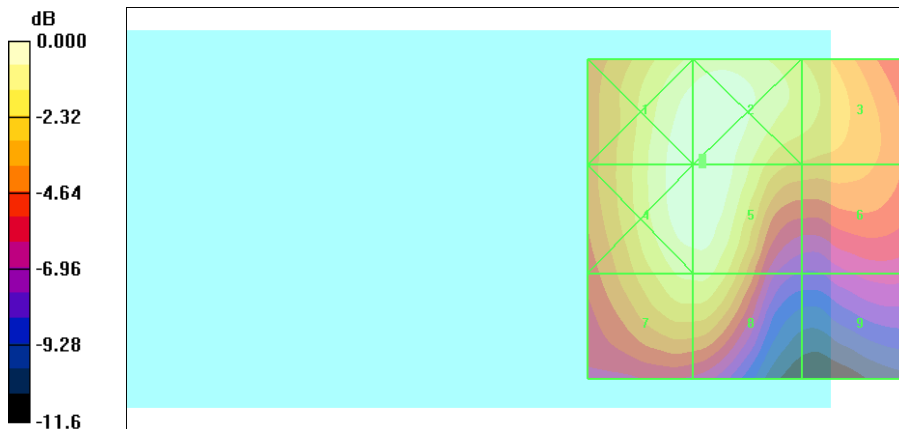

0 dB = 0.266A/m



A Test Lab Techno Corp.

Date/Time: 10/9/2006 6:22:18 PM

**CDMA 1900 CH600\_H**

**DUT: TITA100; Type:Pocket PC Phone; FCC ID:NM8TITA100**

Communication System: PCS 1900; Frequency: 1880 MHz;Duty Cycle: 1:1

Medium parameters used:  $\sigma = 0$  mho/m,  $\epsilon_r = 1$ ;  $\rho = 1$  kg/m<sup>3</sup>

Phantom section: E Device Section

Measurement Standard: DASYS4 (High Precision Assessment)

DASY4 Configuration:

- Probe: H3DV6 - SN6076; ; Calibrated: 10/21/2005
- Sensor-Surface: (Fix Surface)
- Electronics: DAE3 Sn393; Calibrated: 9/5/2006
- Phantom: HAC Test Arch; Type: SD HAC P01 BA
- Measurement SW: DASYS4, V4.7 Build 44; Postprocessing SW: SEMCAD, V1.8 Build 171

**H Scan - H3DV6 probe center 10mm above Device Reference/Hearing Aid Compatibility Test (101x101x1):**

Measurement grid: dx=5mm, dy=5mm

Maximum value of peak Total field = 0.291 A/m

Probe Modulation Factor = 1.08

Reference Value = 0.213 A/m; Power Drift = -0.187 dB

**Hearing Aid Near-Field Category: M3 (AWF 0 dB)**

Peak H-field in A/m

Grid 1	Grid 2	Grid 3
<b>0.289</b>	<b>0.291</b>	<b>0.230</b>
Grid 4	Grid 5	Grid 6
<b>0.289</b>	<b>0.291</b>	<b>0.198</b>
Grid 7	Grid 8	Grid 9
<b>0.251</b>	<b>0.252</b>	<b>0.134</b>

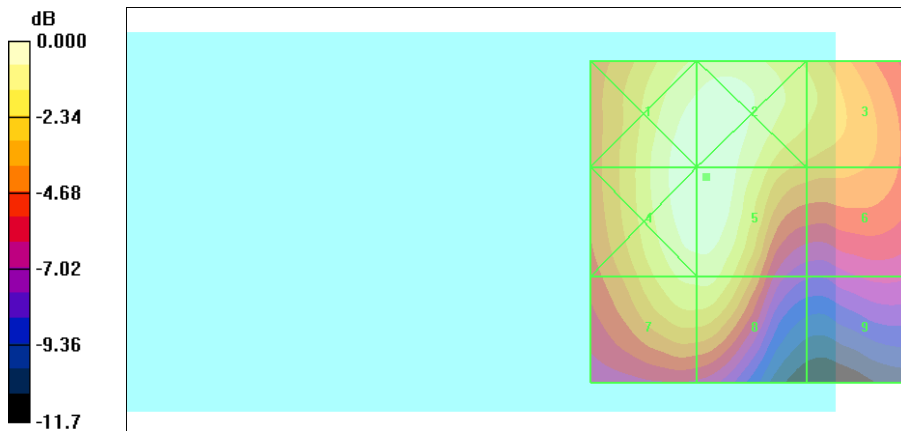

0 dB = 0.291A/m



A Test Lab Techno Corp.

Date/Time: 10/9/2006 6:31:12 PM

**CDMA 1900 CH1175\_H**

**DUT: TITA100; Type:Pocket PC Phone; FCC ID:NM8TITA100**

Communication System: PCS 1900; Frequency: 1908.75 MHz;Duty Cycle: 1:1

Medium parameters used:  $\sigma = 0$  mho/m,  $\epsilon_r = 1$ ;  $\rho = 1$  kg/m<sup>3</sup>

Phantom section: E Device Section

Measurement Standard: DASYS4 (High Precision Assessment)

DASY4 Configuration:

- Probe: H3DV6 - SN6076; ; Calibrated: 10/21/2005
- Sensor-Surface: (Fix Surface)
- Electronics: DAE3 Sn393; Calibrated: 9/5/2006
- Phantom: HAC Test Arch; Type: SD HAC P01 BA
- Measurement SW: DASY4, V4.7 Build 44; Postprocessing SW: SEMCAD, V1.8 Build 171

**H Scan - H3DV6 probe center 10mm above Device Reference/Hearing Aid Compatibility Test (101x101x1):**

Measurement grid: dx=5mm, dy=5mm

Maximum value of peak Total field = 0.285 A/m

Probe Modulation Factor = 1.08

Reference Value = 0.219 A/m; Power Drift = -0.061 dB

**Hearing Aid Near-Field Category: M3 (AWF 0 dB)**

Peak H-field in A/m

Grid 1	Grid 2	Grid 3
<b>0.282</b>	<b>0.284</b>	<b>0.229</b>
Grid 4	Grid 5	Grid 6
<b>0.283</b>	<b>0.285</b>	<b>0.203</b>
Grid 7	Grid 8	Grid 9
<b>0.254</b>	<b>0.254</b>	<b>0.138</b>

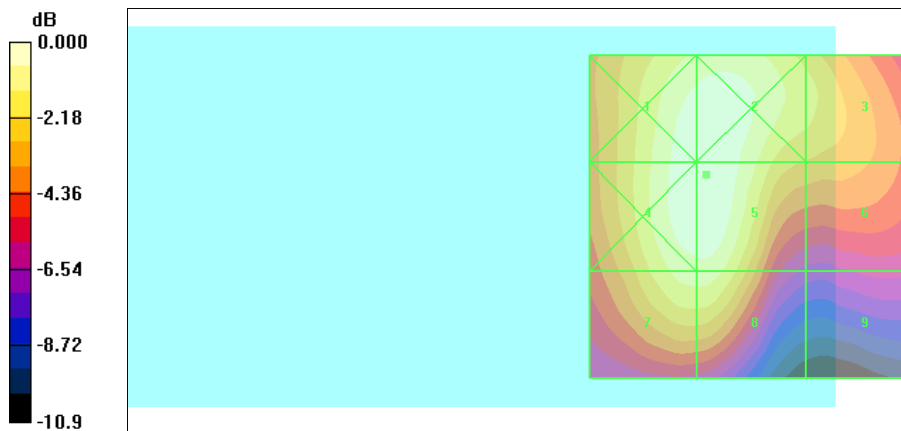

0 dB = 0.285A/m



Test Laboratory: A Test Lab Techno Corp.

Date/Time: 12/13/2006 10:39:36 AM

**HAC\_CDMA Cellular CH1013\_802.11b CH1\_H**

**DUT: TITA100; Type:Pocket PC Phone; FCC ID:NM8TITA100**

Communication System: CDMA Cellular ; Frequency: 824.7 MHz;Duty Cycle: 1:1

Medium parameters used:  $\sigma = 0$  mho/m,  $\epsilon_r = 1$ ;  $\rho = 1$  kg/m<sup>3</sup>

Phantom section: E Device Section

Measurement Standard: DASYS4 (High Precision Assessment)

DASY4 Configuration:

- Probe: H3DV6 - SN6076; ; Calibrated: 10/21/2005
- Sensor-Surface: (Fix Surface)
- Electronics: DAE3 Sn393; Calibrated: 9/5/2006
- Phantom: HAC Test Arch; Type: SD HAC P01 BA; Serial:
- Measurement SW: DASYS4, V4.7 Build 44; Postprocessing SW: SEMCAD, V1.8 Build 171

**H Scan - H3DV6 probe center 10mm above Device Reference/Hearing Aid Compatibility Test (101x101x1):**

Measurement grid: dx=5mm, dy=5mm

Maximum value of peak Total field = 0.328 A/m

Probe Modulation Factor = 1.25

Reference Value = 0.202 A/m; Power Drift = 0.027 dB

**Hearing Aid Near-Field Category: M4 (AWF 0 dB)**

Peak H-field in A/m

Grid 1	Grid 2	Grid 3
<b>0.331</b>	<b>0.363</b>	<b>0.351</b>
Grid 4	Grid 5	Grid 6
<b>0.315</b>	<b>0.328</b>	<b>0.317</b>
Grid 7	Grid 8	Grid 9
<b>0.254</b>	<b>0.258</b>	<b>0.226</b>

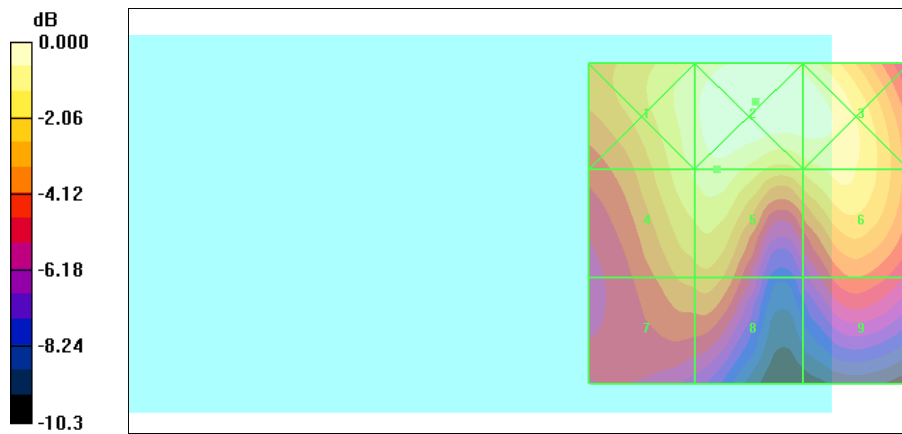

0 dB = 0.363A/m



Test Laboratory: A Test Lab Techno Corp.

Date/Time: 12/13/2006 10:32:52 AM

**HAC\_CDMA Cellular CH384\_802.11b CH1\_H**

**DUT: TITA100; Type:Pocket PC Phone; FCC ID:NM8TITA100**

Communication System: CDMA Cellular ; Frequency: 836.52 MHz;Duty Cycle: 1:1

Medium parameters used:  $\sigma = 0$  mho/m,  $\epsilon_r = 1$ ;  $\rho = 1$  kg/m<sup>3</sup>

Phantom section: E Device Section

Measurement Standard: DASY4 (High Precision Assessment)

DASY4 Configuration:

- Probe: H3DV6 - SN6076; ; Calibrated: 10/21/2005
- Sensor-Surface: (Fix Surface)
- Electronics: DAE3 Sn393; Calibrated: 9/5/2006
- Phantom: HAC Test Arch; Type: SD HAC P01 BA; Serial:
- Measurement SW: DASY4, V4.7 Build 44; Postprocessing SW: SEMCAD, V1.8 Build 171

**H Scan - H3DV6 probe center 10mm above Device Reference/Hearing Aid Compatibility Test (101x101x1):**

Measurement grid: dx=5mm, dy=5mm

Maximum value of peak Total field = 0.366 A/m

Probe Modulation Factor = 1.25

Reference Value = 0.227 A/m; Power Drift = -0.122 dB

**Hearing Aid Near-Field Category: M4 (AWF 0 dB)**

Peak H-field in A/m

Grid 1	Grid 2	Grid 3
<b>0.369</b>	<b>0.406</b>	<b>0.396</b>
Grid 4	Grid 5	Grid 6
<b>0.351</b>	<b>0.366</b>	<b>0.357</b>
Grid 7	Grid 8	Grid 9
<b>0.283</b>	<b>0.288</b>	<b>0.253</b>

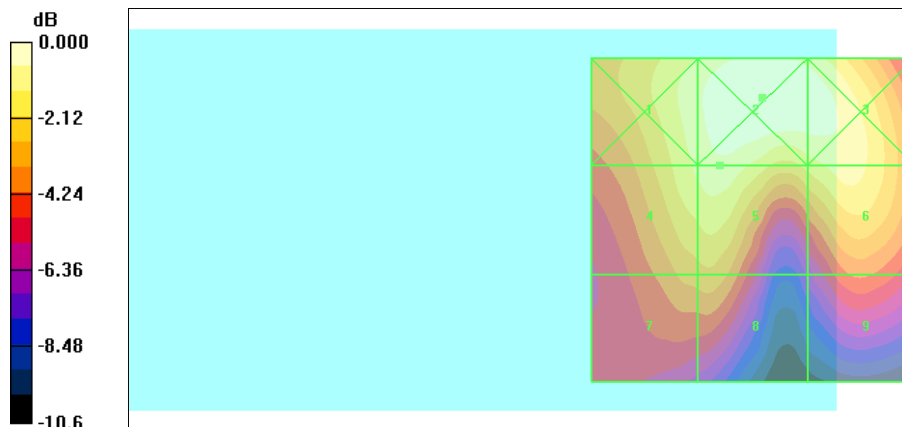

0 dB = 0.406A/m



Test Laboratory: A Test Lab Techno Corp.

Date/Time: 12/13/2006 11:23:55 AM

**HAC\_CDMA Cellular CH777\_802.11b CH1\_H**

**DUT: TITA100; Type:Pocket PC Phone; FCC ID:NM8TITA100**

Communication System: CDMA Cellular ; Frequency: 848.31 MHz;Duty Cycle: 1:1

Medium parameters used:  $\sigma = 0$  mho/m,  $\epsilon_r = 1$ ;  $\rho = 1$  kg/m<sup>3</sup>

Phantom section: E Device Section

Measurement Standard: DASY4 (High Precision Assessment)

DASY4 Configuration:

- Probe: H3DV6 - SN6076; ; Calibrated: 10/21/2005
- Sensor-Surface: (Fix Surface)
- Electronics: DAE3 Sn393; Calibrated: 9/5/2006
- Phantom: HAC Test Arch; Type: SD HAC P01 BA; Serial:
- Measurement SW: DASY4, V4.7 Build 44; Postprocessing SW: SEMCAD, V1.8 Build 171

**H Scan - H3DV6 probe center 10mm above Device Reference/Hearing Aid Compatibility Test (101x101x1):**

Measurement grid: dx=5mm, dy=5mm

Maximum value of peak Total field = 0.306 A/m

Probe Modulation Factor = 1.25

Reference Value = 0.190 A/m; Power Drift = -0.091 dB

**Hearing Aid Near-Field Category: M4 (AWF 0 dB)**

Peak H-field in A/m

Grid 1	Grid 2	Grid 3
<b>0.307</b>	<b>0.336</b>	<b>0.326</b>
Grid 4	Grid 5	Grid 6
<b>0.295</b>	<b>0.306</b>	<b>0.296</b>
Grid 7	Grid 8	Grid 9
<b>0.244</b>	<b>0.247</b>	<b>0.216</b>

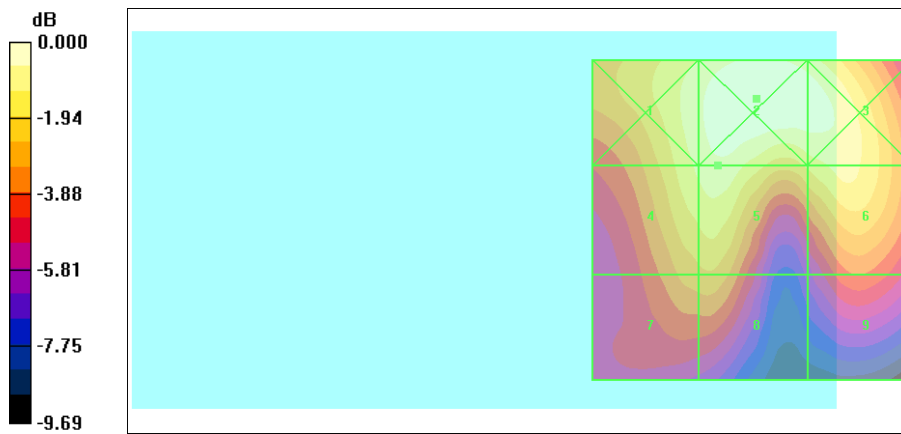

0 dB = 0.336A/m





Test Laboratory: A Test Lab Techno Corp.

Date/Time: 12/13/2006 11:47:58 AM

**HAC\_CDMA PCS CH25\_802.11b CH1\_H**

**DUT:TITA100; Type:Pocket PC Phone; FCC ID:NM8TITA100**

Communication System: CDMA PCS ; Frequency: 1851.25 MHz;Duty Cycle: 1:1

Medium parameters used:  $\sigma = 0$  mho/m,  $\epsilon_r = 1$ ;  $\rho = 1$  kg/m<sup>3</sup>

Phantom section: E Device Section

Measurement Standard: DASYS4 (High Precision Assessment)

DASY4 Configuration:

- Probe: H3DV6 - SN6076; ; Calibrated: 10/21/2005
- Sensor-Surface: (Fix Surface)
- Electronics: DAE3 Sn393; Calibrated: 9/5/2006
- Phantom: HAC Test Arch; Type: SD HAC P01 BA; Serial:
- Measurement SW: DASYS4, V4.7 Build 44; Postprocessing SW: SEMCAD, V1.8 Build 171

**H Scan - H3DV6 probe center 10mm above Device Reference/Hearing Aid Compatibility Test (101x101x1):**

Measurement grid: dx=5mm,dy=5mm

Maximum value of peak Total field = 0.180 A/m

Probe Modulation Factor = 1.08

Reference Value = 0.150 A/m; Power Drift = 0.014 dB

**Hearing Aid Near-Field Category: M4 (AWF 0 dB)**

Peak H-field in A/m

Grid 1	Grid 2	Grid 3
<b>0.172</b>	<b>0.192</b>	<b>0.178</b>
Grid 4	Grid 5	Grid 6
<b>0.168</b>	<b>0.180</b>	<b>0.151</b>
Grid 7	Grid 8	Grid 9
<b>0.149</b>	<b>0.155</b>	<b>0.105</b>

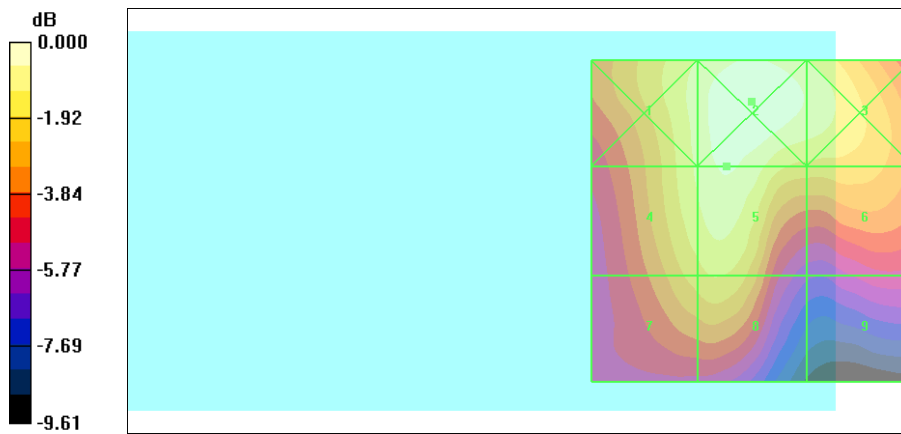

0 dB = 0.192A/m



Test Laboratory: A Test Lab Techno Corp.

Date/Time: 12/13/2006 11:42:16 AM

**HAC\_CDMA PCS CH600\_802.11b CH1\_H**

**DUT: TITA100; Type:Pocket PC Phone; FCC ID:NM8TITA100**

Communication System: CDMA PCS ; Frequency: 1880 MHz;Duty Cycle: 1:1

Medium parameters used:  $\sigma = 0$  mho/m,  $\epsilon_r = 1$ ;  $\rho = 1$  kg/m<sup>3</sup>

Phantom section: E Device Section

Measurement Standard: DAS4 (High Precision Assessment)

DASY4 Configuration:

- Probe: H3DV6 - SN6076; ; Calibrated: 10/21/2005
- Sensor-Surface: (Fix Surface)
- Electronics: DAE3 Sn393; Calibrated: 9/5/2006
- Phantom: HAC Test Arch; Type: SD HAC P01 BA; Serial:
- Measurement SW: DAS4, V4.7 Build 44; Postprocessing SW: SEMCAD, V1.8 Build 171

**H Scan - H3DV6 probe center 10mm above Device Reference/Hearing Aid Compatibility Test (101x101x1):**

Measurement grid: dx=5mm, dy=5mm

Maximum value of peak Total field = 0.192 A/m

Probe Modulation Factor = 1.08

Reference Value = 0.163 A/m; Power Drift = -0.007 dB

**Hearing Aid Near-Field Category: M3 (AWF 0 dB)**

Peak H-field in A/m

Grid 1	Grid 2	Grid 3
<b>0.183</b>	<b>0.204</b>	<b>0.190</b>
Grid 4	Grid 5	Grid 6
<b>0.179</b>	<b>0.192</b>	<b>0.163</b>
Grid 7	Grid 8	Grid 9
<b>0.161</b>	<b>0.167</b>	<b>0.113</b>

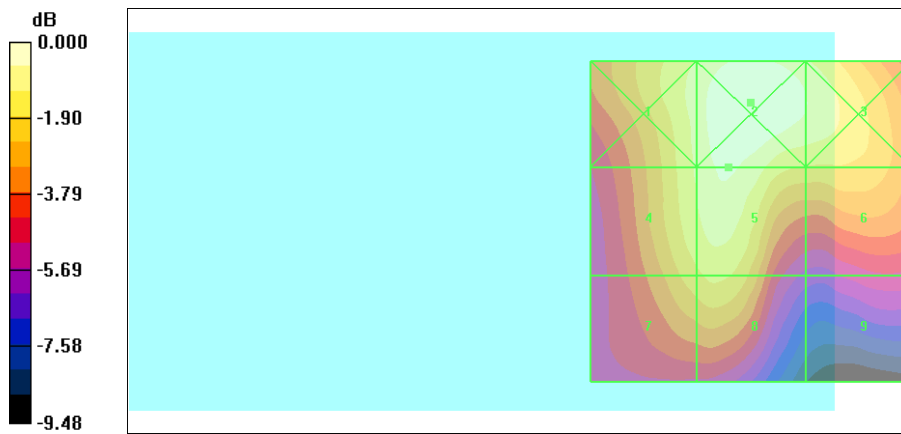

0 dB = 0.204A/m



Test Laboratory: A Test Lab Techno Corp.

Date/Time: 12/13/2006 11:54:20 AM

**HAC\_CDMA PCS CH1175\_802.11b CH1\_H**

**DUT: TITA100; Type:Pocket PC Phone; FCC ID:NM8TITA100**

Communication System: CDMA PCS ; Frequency: 1908.75 MHz;Duty Cycle: 1:1

Medium parameters used:  $\sigma = 0$  mho/m,  $\epsilon_r = 1$ ;  $\rho = 1$  kg/m<sup>3</sup>

Phantom section: E Device Section

Measurement Standard: DAS4 (High Precision Assessment)

DASY4 Configuration:

- Probe: H3DV6 - SN6076; ; Calibrated: 10/21/2005
- Sensor-Surface: (Fix Surface)
- Electronics: DAE3 Sn393; Calibrated: 9/5/2006
- Phantom: HAC Test Arch; Type: SD HAC P01 BA; Serial:
- Measurement SW: DAS4, V4.7 Build 44; Postprocessing SW: SEMCAD, V1.8 Build 171

**H Scan - H3DV6 probe center 10mm above Device Reference/Hearing Aid Compatibility Test (101x101x1):**

Measurement grid: dx=5mm, dy=5mm

Maximum value of peak Total field = 0.182 A/m

Probe Modulation Factor = 1.08

Reference Value = 0.156 A/m; Power Drift = -0.094 dB

**Hearing Aid Near-Field Category: M4 (AWF 0 dB)**

Peak H-field in A/m

Grid 1	Grid 2	Grid 3
<b>0.173</b>	<b>0.192</b>	<b>0.180</b>
Grid 4	Grid 5	Grid 6
<b>0.169</b>	<b>0.182</b>	<b>0.157</b>
Grid 7	Grid 8	Grid 9
<b>0.151</b>	<b>0.157</b>	<b>0.111</b>

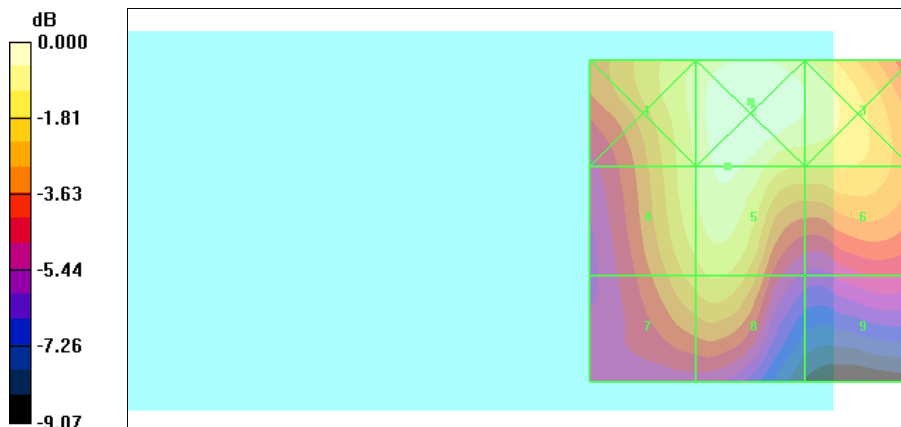

0 dB = 0.192A/m



Test Laboratory: A Test Lab Techno Corp.

Date/Time: 12/13/2006 1:58:18 PM

**HAC\_CDMA cellular CH1013\_802.11g CH1\_H**

**DUT: TITA100; Type:Pocket PC Phone; FCC ID:NM8TITA100**

Communication System: CDMA Cellular ; Frequency: 824.7 MHz;Duty Cycle: 1:1

Medium parameters used:  $\sigma = 0$  mho/m,  $\epsilon_r = 1$ ;  $\rho = 1$  kg/m<sup>3</sup>

Phantom section: E Device Section

Measurement Standard: DAS4 (High Precision Assessment)

DASY4 Configuration:

- Probe: H3DV6 - SN6076; ; Calibrated: 10/21/2005
- Sensor-Surface: (Fix Surface)
- Electronics: DAE3 Sn393; Calibrated: 9/5/2006
- Phantom: HAC Test Arch; Type: SD HAC P01 BA; Serial:
- Measurement SW: DAS4, V4.7 Build 44; Postprocessing SW: SEMCAD, V1.8 Build 171

**H Scan - H3DV6 probe center 10mm above Device Reference/Hearing Aid Compatibility Test (101x101x1):**

Measurement grid: dx=5mm, dy=5mm

Maximum value of peak Total field = 0.341 A/m

Probe Modulation Factor = 1.25

Reference Value = 0.210 A/m; Power Drift = -0.036 dB

**Hearing Aid Near-Field Category: M4 (AWF 0 dB)**

Peak H-field in A/m

Grid 1	Grid 2	Grid 3
<b>0.344</b>	<b>0.376</b>	<b>0.363</b>
Grid 4	Grid 5	Grid 6
<b>0.328</b>	<b>0.341</b>	<b>0.327</b>
Grid 7	Grid 8	Grid 9
<b>0.264</b>	<b>0.268</b>	<b>0.234</b>



0 dB = 0.376A/m



Test Laboratory: A Test Lab Techno Corp.

Date/Time: 12/13/2006 1:51:15 PM

**HAC\_CDMA cellular CH384\_802.11g CH1\_H**

**DUT: TITA100; Type:Pocket PC Phone; FCC ID:NM8TITA100**

Communication System: CDMA Cellular ; Frequency: 836.52 MHz;Duty Cycle: 1:1

Medium parameters used:  $\sigma = 0$  mho/m,  $\epsilon_r = 1$ ;  $\rho = 1$  kg/m<sup>3</sup>

Phantom section: E Device Section

Measurement Standard: DAS4 (High Precision Assessment)

DASY4 Configuration:

- Probe: H3DV6 - SN6076; ; Calibrated: 10/21/2005
- Sensor-Surface: (Fix Surface)
- Electronics: DAE3 Sn393; Calibrated: 9/5/2006
- Phantom: HAC Test Arch; Type: SD HAC P01 BA; Serial:
- Measurement SW: DAS4, V4.7 Build 44; Postprocessing SW: SEMCAD, V1.8 Build 171

**H Scan - H3DV6 probe center 10mm above Device Reference/Hearing Aid Compatibility Test (101x101x1):**

Measurement grid: dx=5mm, dy=5mm

Maximum value of peak Total field = 0.381 A/m

Probe Modulation Factor = 1.25

Reference Value = 0.216 A/m; Power Drift = -0.006 dB

**Hearing Aid Near-Field Category: M4 (AWF 0 dB)**

Peak H-field in A/m

Grid 1	Grid 2	Grid 3
<b>0.384</b>	<b>0.418</b>	<b>0.406</b>
Grid 4	Grid 5	Grid 6
<b>0.367</b>	<b>0.381</b>	<b>0.368</b>
Grid 7	Grid 8	Grid 9
<b>0.296</b>	<b>0.301</b>	<b>0.260</b>

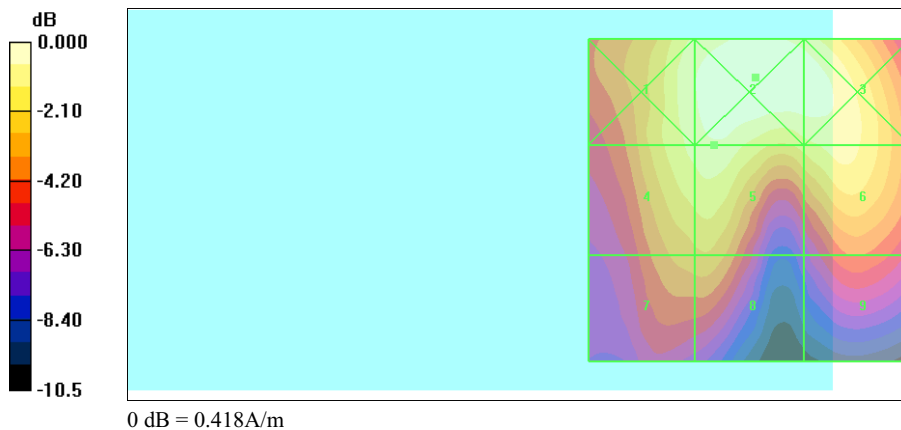



Test Laboratory: A Test Lab Techno Corp.

Date/Time: 12/13/2006 2:04:33 PM

**HAC\_CDMA cellular CH777\_802.11g CH1\_H**

**DUT: TITA100; Type:Pocket PC Phone; FCC ID:NM8TITA100**

Communication System: CDMA Cellular ; Frequency: 848.31 MHz;Duty Cycle: 1:1

Medium parameters used:  $\sigma = 0$  mho/m,  $\epsilon_r = 1$ ;  $\rho = 1$  kg/m<sup>3</sup>

Phantom section: E Device Section

Measurement Standard: DASYS4 (High Precision Assessment)

DASY4 Configuration:

- Probe: H3DV6 - SN6076; ; Calibrated: 10/21/2005
- Sensor-Surface: (Fix Surface)
- Electronics: DAE3 Sn393; Calibrated: 9/5/2006
- Phantom: HAC Test Arch; Type: SD HAC P01 BA; Serial:
- Measurement SW: DASYS4, V4.7 Build 44; Postprocessing SW: SEMCAD, V1.8 Build 171

**H Scan - H3DV6 probe center 10mm above Device Reference/Hearing Aid Compatibility Test (101x101x1):**

Measurement grid: dx=5mm, dy=5mm

Maximum value of peak Total field = 0.316 A/m

Probe Modulation Factor = 1.25

Reference Value = 0.195 A/m; Power Drift = -0.078 dB

**Hearing Aid Near-Field Category: M4 (AWF 0 dB)**

Peak H-field in A/m

Grid 1	Grid 2	Grid 3
<b>0.316</b>	<b>0.345</b>	<b>0.331</b>
Grid 4	Grid 5	Grid 6
<b>0.303</b>	<b>0.316</b>	<b>0.300</b>
Grid 7	Grid 8	Grid 9
<b>0.246</b>	<b>0.250</b>	<b>0.217</b>

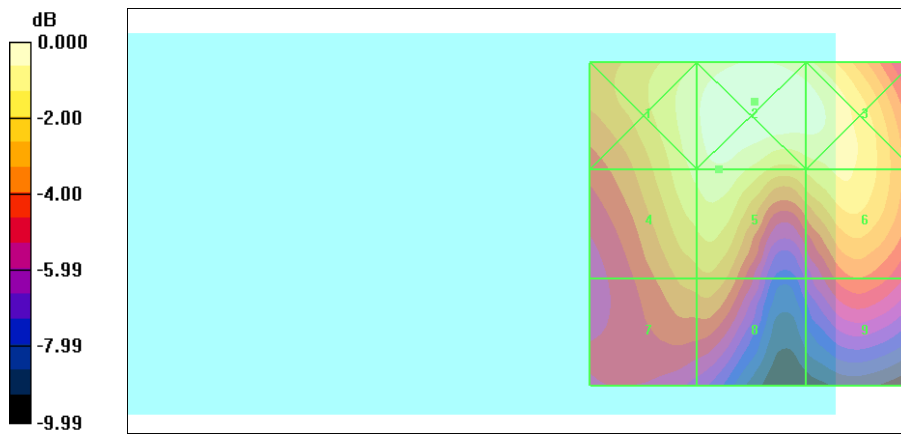

0 dB = 0.345A/m



Test Laboratory: A Test Lab Techno Corp.

Date/Time: 12/13/2006 2:12:18 PM

**HAC\_CDMA PCS CH25\_802.11g CH1\_H**

**DUT: TITA100; Type:Pocket PC Phone; FCC ID:NM8TITA100**

Communication System: CDMA PCS ; Frequency: 1851.25 MHz;Duty Cycle: 1:1

Medium parameters used:  $\sigma = 0$  mho/m,  $\epsilon_r = 1$ ;  $\rho = 1$  kg/m<sup>3</sup>

Phantom section: E Device Section

Measurement Standard: DAS4 (High Precision Assessment)

DASY4 Configuration:

- Probe: H3DV6 - SN6076; ; Calibrated: 10/21/2005
- Sensor-Surface: (Fix Surface)
- Electronics: DAE3 Sn393; Calibrated: 9/5/2006
- Phantom: HAC Test Arch; Type: SD HAC P01 BA; Serial:
- Measurement SW: DAS4, V4.7 Build 44; Postprocessing SW: SEMCAD, V1.8 Build 171

**H Scan - H3DV6 probe center 10mm above Device Reference/Hearing Aid Compatibility Test (101x101x1):**

Measurement grid: dx=5mm, dy=5mm

Maximum value of peak Total field = 0.192 A/m

Probe Modulation Factor = 1.08

Reference Value = 0.164 A/m; Power Drift = -0.145 dB

**Hearing Aid Near-Field Category: M3 (AWF 0 dB)**

Peak H-field in A/m

Grid 1	Grid 2	Grid 3
<b>0.182</b>	<b>0.199</b>	<b>0.182</b>
Grid 4	Grid 5	Grid 6
<b>0.180</b>	<b>0.192</b>	<b>0.155</b>
Grid 7	Grid 8	Grid 9
<b>0.159</b>	<b>0.165</b>	<b>0.105</b>

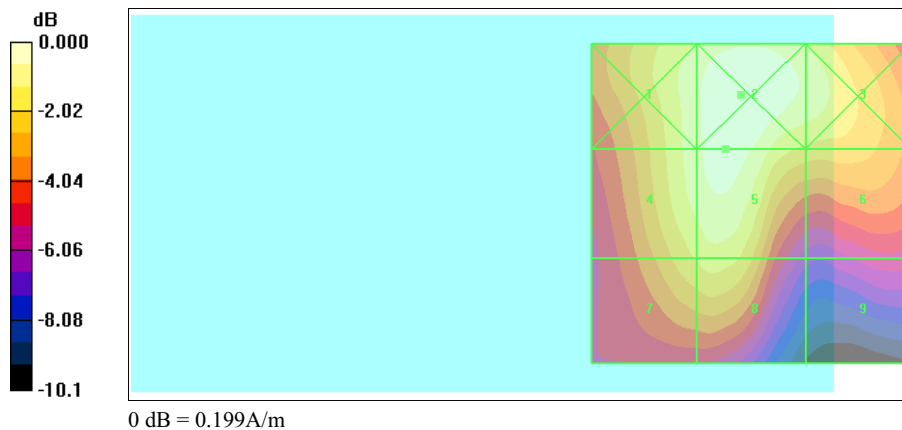



Test Laboratory: A Test Lab Techno Corp.

Date/Time: 12/13/2006 2:19:24 PM

**HAC\_CDMA PCS CH600\_802.11g CH1\_H**

**DUT:TITA100; Type:Pocket PC Phone; FCC ID:NM8TITA100**

Communication System: CDMA PCS ; Frequency: 1880 MHz;Duty Cycle: 1:1

Medium parameters used:  $\sigma = 0$  mho/m,  $\epsilon_r = 1$ ;  $\rho = 1$  kg/m<sup>3</sup>

Phantom section: E Device Section

Measurement Standard: DASYS4 (High Precision Assessment)

DASY4 Configuration:

- Probe: H3DV6 - SN6076; ; Calibrated: 10/21/2005
- Sensor-Surface: (Fix Surface)
- Electronics: DAE3 Sn393; Calibrated: 9/5/2006
- Phantom: HAC Test Arch; Type: SD HAC P01 BA; Serial:
- Measurement SW: DASYS4, V4.7 Build 44; Postprocessing SW: SEMCAD, V1.8 Build 171

**H Scan - H3DV6 probe center 10mm above Device Reference/Hearing Aid Compatibility Test (101x101x1):**

Measurement grid: dx=5mm, dy=5mm

Maximum value of peak Total field = 0.207 A/m

Probe Modulation Factor = 1.08

Reference Value = 0.176 A/m; Power Drift = -0.110 dB

**Hearing Aid Near-Field Category: M3 (AWF 0 dB)**

Peak H-field in A/m

Grid 1	Grid 2	Grid 3
<b>0.196</b>	<b>0.216</b>	<b>0.199</b>
Grid 4	Grid 5	Grid 6
<b>0.194</b>	<b>0.207</b>	<b>0.171</b>
Grid 7	Grid 8	Grid 9
<b>0.171</b>	<b>0.179</b>	<b>0.116</b>

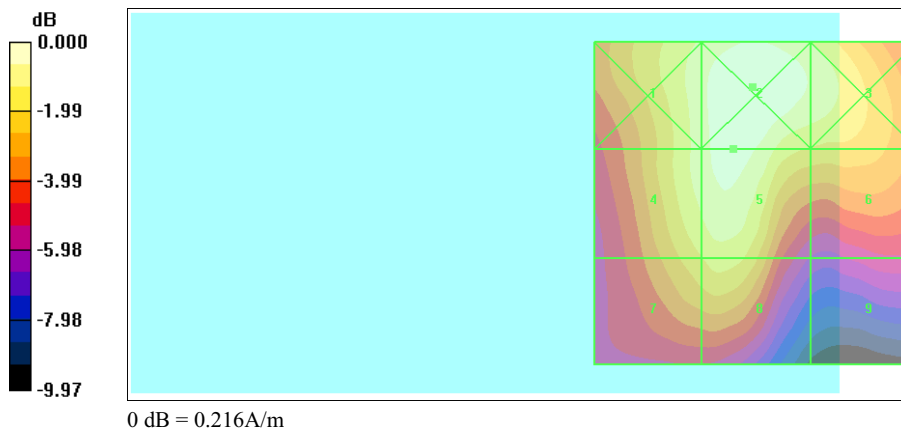





Test Laboratory: A Test Lab Techno Corp.

Date/Time: 12/13/2006 2:25:05 PM

**HAC\_CDMA PCS CH1175\_802.11g CH1\_H**

**DUT: TITA100; Type:Pocket PC Phone; FCC ID:NM8TITA100**

Communication System: CDMA PCS ; Frequency: 1908.75 MHz;Duty Cycle: 1:1

Medium parameters used:  $\sigma = 0$  mho/m,  $\epsilon_r = 1$ ;  $\rho = 1$  kg/m<sup>3</sup>

Phantom section: E Device Section

Measurement Standard: DASYS4 (High Precision Assessment)

DASY4 Configuration:

- Probe: H3DV6 - SN6076; ; Calibrated: 10/21/2005
- Sensor-Surface: (Fix Surface)
- Electronics: DAE3 Sn393; Calibrated: 9/5/2006
- Phantom: HAC Test Arch; Type: SD HAC P01 BA; Serial:
- Measurement SW: DASYS4, V4.7 Build 44; Postprocessing SW: SEMCAD, V1.8 Build 171

**H Scan - H3DV6 probe center 10mm above Device Reference/Hearing Aid Compatibility Test (101x101x1):**

Measurement grid: dx=5mm, dy=5mm

Maximum value of peak Total field = 0.197 A/m

Probe Modulation Factor = 1.08

Reference Value = 0.170 A/m; Power Drift = -0.129 dB

**Hearing Aid Near-Field Category: M3 (AWF 0 dB)**

Peak H-field in A/m

Grid 1	Grid 2	Grid 3
<b>0.186</b>	<b>0.205</b>	<b>0.188</b>
Grid 4	Grid 5	Grid 6
<b>0.184</b>	<b>0.197</b>	<b>0.166</b>
Grid 7	Grid 8	Grid 9
<b>0.165</b>	<b>0.172</b>	<b>0.115</b>

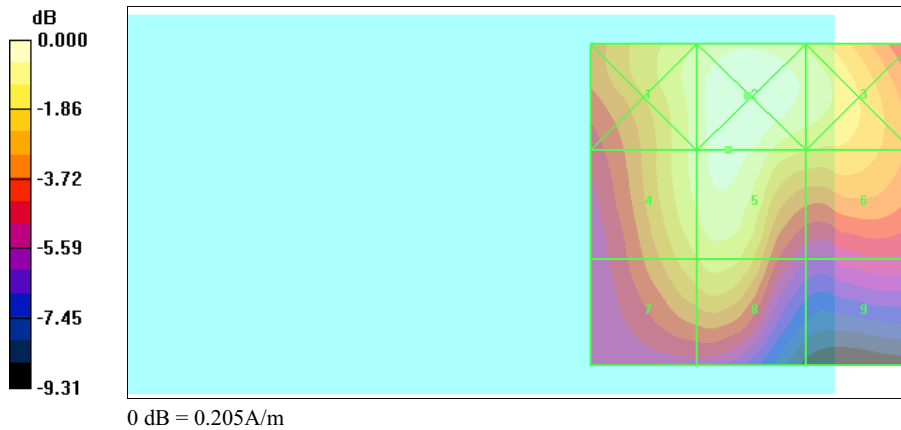



Test Laboratory: A Test Lab Techno Corp.

Date/Time: 12/19/2006 10:04:45 AM

**HAC\_CDMA Cellular CH1013\_Bluetooth CH39\_H**

**DUT:TITA100; Type:Pocket PC Phone; FCC ID:NM8TITA100**

Communication System: CDMA Cellular ; Frequency: 824.7 MHz;Duty Cycle: 1:1

Medium parameters used:  $\sigma = 0$  mho/m,  $\epsilon_r = 1$ ;  $\rho = 1$  kg/m<sup>3</sup>

Phantom section: H Device Section

Measurement Standard: DASYS4 (High Precision Assessment)

DASY4 Configuration:

- Probe: H3DV6 - SN6076; ; Calibrated: 10/21/2005
- Sensor-Surface: (Fix Surface)
- Electronics: DAE3 Sn393; Calibrated: 9/5/2006
- Phantom: HAC Test Arch; Type: SD HAC P01 BA; Serial:
- Measurement SW: DASYS4, V4.7 Build 44; Postprocessing SW: SEMCAD, V1.8 Build 171

**H Scan - H3DV6 probe center 10mm above Device Reference/Hearing Aid Compatibility Test (101x101x1):**

Measurement grid: dx=5mm, dy=5mm

Maximum value of peak Total field = 0.336 A/m

Probe Modulation Factor = 1.25

Reference Value = 0.195 A/m; Power Drift = -0.006 dB

**Hearing Aid Near-Field Category: M4 (AWF 0 dB)**

Peak H-field in A/m

Grid 1	Grid 2	Grid 3
<b>0.331</b>	<b>0.370</b>	<b>0.359</b>
Grid 4	Grid 5	Grid 6
<b>0.320</b>	<b>0.336</b>	<b>0.322</b>
Grid 7	Grid 8	Grid 9
<b>0.252</b>	<b>0.257</b>	<b>0.226</b>

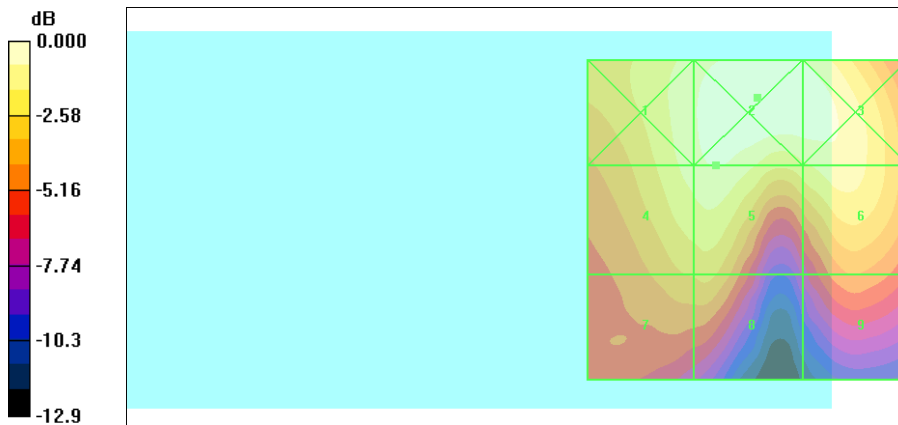

0 dB = 0.370A/m



Test Laboratory: A Test Lab Techno Corp.

Date/Time: 12/19/2006 9:57:24 AM

**HAC\_CDMA Cellular CH384\_Bluetooth CH39\_H**

**DUT: TITA100; Type:Pocket PC Phone; FCC ID:NM8TITA100**

Communication System: CDMA Cellular ; Frequency: 836.52 MHz;Duty Cycle: 1:1

Medium parameters used:  $\sigma = 0$  mho/m,  $\epsilon_r = 1$ ;  $\rho = 1$  kg/m<sup>3</sup>

Phantom section: H Device Section

Measurement Standard: DASYS4 (High Precision Assessment)

DASY4 Configuration:

- Probe: H3DV6 - SN6076; ; Calibrated: 10/21/2005
- Sensor-Surface: (Fix Surface)
- Electronics: DAE3 Sn393; Calibrated: 9/5/2006
- Phantom: HAC Test Arch; Type: SD HAC P01 BA; Serial:
- Measurement SW: DASYS4, V4.7 Build 44; Postprocessing SW: SEMCAD, V1.8 Build 171

**H Scan - H3DV6 probe center 10mm above Device Reference/Hearing Aid Compatibility Test (101x101x1):**

Measurement grid: dx=5mm, dy=5mm

Maximum value of peak Total field = 0.372 A/m

Probe Modulation Factor = 1.25

Reference Value = 0.218 A/m; Power Drift = -0.053 dB

**Hearing Aid Near-Field Category: M4 (AWF 0 dB)**

Peak H-field in A/m

Grid 1	Grid 2	Grid 3
<b>0.373</b>	<b>0.412</b>	<b>0.400</b>
Grid 4	Grid 5	Grid 6
<b>0.360</b>	<b>0.372</b>	<b>0.357</b>
Grid 7	Grid 8	Grid 9
<b>0.282</b>	<b>0.286</b>	<b>0.251</b>

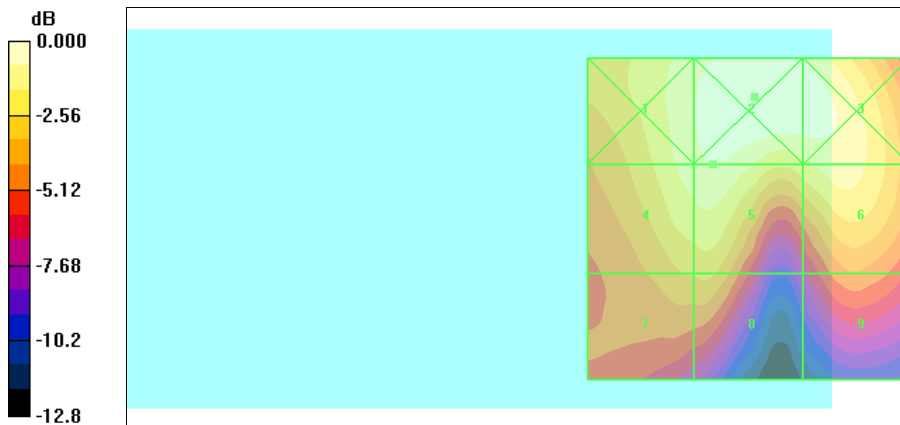

0 dB = 0.412A/m



Test Laboratory: A Test Lab Techno Corp.

Date/Time: 12/19/2006 10:12:54 AM

**HAC\_CDMA Cellular CH777\_Bluetooth CH39\_H**

**DUT: TITA100; Type:Pocket PC Phone; FCC ID:NM8TITA100**

Communication System: CDMA Cellular ; Frequency: 848.31 MHz;Duty Cycle: 1:1

Medium parameters used:  $\sigma = 0$  mho/m,  $\epsilon_r = 1$ ;  $\rho = 1$  kg/m<sup>3</sup>

Phantom section: H Device Section

Measurement Standard: DASYS4 (High Precision Assessment)

DASY4 Configuration:

- Probe: H3DV6 - SN6076; ; Calibrated: 10/21/2005
- Sensor-Surface: (Fix Surface)
- Electronics: DAE3 Sn393; Calibrated: 9/5/2006
- Phantom: HAC Test Arch; Type: SD HAC P01 BA; Serial:
- Measurement SW: DASYS4, V4.7 Build 44; Postprocessing SW: SEMCAD, V1.8 Build 171

**H Scan - H3DV6 probe center 10mm above Device Reference/Hearing Aid Compatibility Test (101x101x1):**

Measurement grid: dx=5mm, dy=5mm

Maximum value of peak Total field = 0.307 A/m

Probe Modulation Factor = 1.25

Reference Value = 0.181 A/m; Power Drift = 0.087 dB

**Hearing Aid Near-Field Category: M4 (AWF 0 dB)**

Peak H-field in A/m

Grid 1	Grid 2	Grid 3
<b>0.303</b>	<b>0.338</b>	<b>0.328</b>
Grid 4	Grid 5	Grid 6
<b>0.294</b>	<b>0.307</b>	<b>0.298</b>
Grid 7	Grid 8	Grid 9
<b>0.233</b>	<b>0.238</b>	<b>0.211</b>

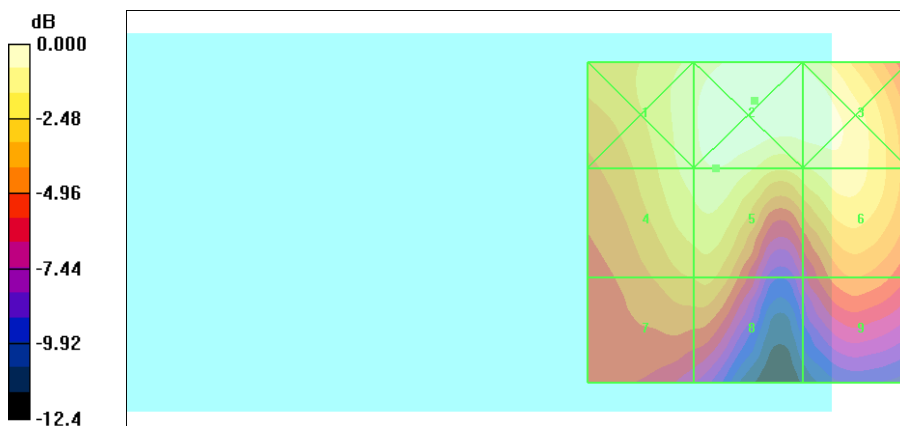



Test Laboratory: A Test Lab Techno Corp.

Date/Time: 12/19/2006 11:47:22 AM

**HAC\_CDMA PCS CH25\_Bluetooth CH39\_H**

**DUT: TITA100; Type:Pocket PC Phone; FCC ID:NM8TITA100**

Communication System: CDMA PCS ; Frequency: 1851.25 MHz;Duty Cycle: 1:1

Medium parameters used:  $\sigma = 0$  mho/m,  $\epsilon_r = 1$ ;  $\rho = 1$  kg/m<sup>3</sup>

Phantom section: H Device Section

Measurement Standard: DASYS4 (High Precision Assessment)

DASY4 Configuration:

- Probe: H3DV6 - SN6076; ; Calibrated: 10/21/2005
- Sensor-Surface: (Fix Surface)
- Electronics: DAE3 Sn393; Calibrated: 9/5/2006
- Phantom: HAC Test Arch; Type: SD HAC P01 BA; Serial:
- Measurement SW: DASYS4, V4.7 Build 44; Postprocessing SW: SEMCAD, V1.8 Build 171

**H Scan - H3DV6 probe center 10mm above Device Reference/Hearing Aid Compatibility Test (101x101x1):**

Measurement grid: dx=5mm, dy=5mm

Maximum value of peak Total field = 0.225 A/m

Probe Modulation Factor = 1.08

Reference Value = 0.186 A/m; Power Drift = -0.052 dB

**Hearing Aid Near-Field Category: M3 (AWF 0 dB)**

Peak H-field in A/m

Grid 1	Grid 2	Grid 3
<b>0.208</b>	<b>0.225</b>	<b>0.195</b>
Grid 4	Grid 5	Grid 6
<b>0.209</b>	<b>0.225</b>	<b>0.168</b>
Grid 7	Grid 8	Grid 9
<b>0.183</b>	<b>0.193</b>	<b>0.111</b>

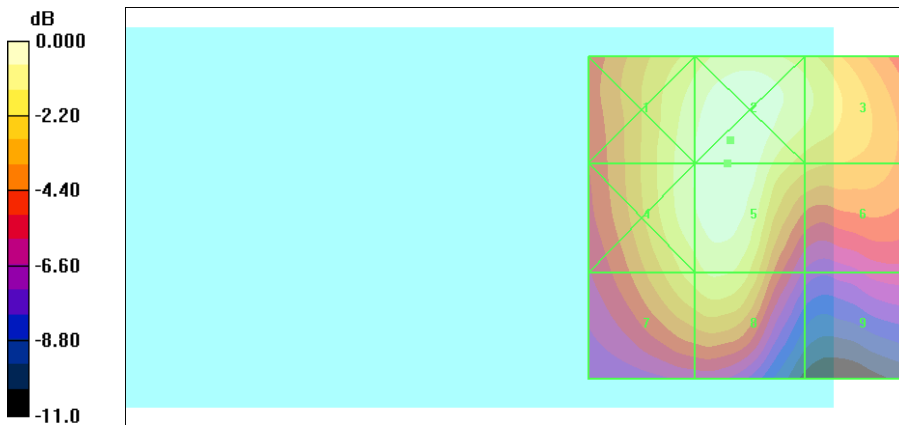

0 dB = 0.225A/m



Test Laboratory: A Test Lab Techno Corp.

Date/Time: 12/19/2006 11:55:03 AM

**HAC\_CDMA PCS CH600\_Bluetooth CH39\_H**

**DUT: TITA100; Type:Pocket PC Phone; FCC ID:NM8TITA100**

Communication System: CDMA PCS ; Frequency: 1851.25 MHz;Duty Cycle: 1:1

Medium parameters used:  $\sigma = 0$  mho/m,  $\epsilon_r = 1$ ;  $\rho = 1$  kg/m<sup>3</sup>

Phantom section: H Device Section

Measurement Standard: DASYS4 (High Precision Assessment)

DASY4 Configuration:

- Probe: H3DV6 - SN6076; ; Calibrated: 10/21/2005
- Sensor-Surface: (Fix Surface)
- Electronics: DAE3 Sn393; Calibrated: 9/5/2006
- Phantom: HAC Test Arch; Type: SD HAC P01 BA; Serial:
- Measurement SW: DASYS4, V4.7 Build 44; Postprocessing SW: SEMCAD, V1.8 Build 171

**H Scan - H3DV6 probe center 10mm above Device Reference/Hearing Aid Compatibility Test (101x101x1):**

Measurement grid: dx=5mm, dy=5mm

Maximum value of peak Total field = 0.233 A/m

Probe Modulation Factor = 1.08

Reference Value = 0.199 A/m; Power Drift = 0.066 dB

**Hearing Aid Near-Field Category: M3 (AWF 0 dB)**

Peak H-field in A/m

Grid 1	Grid 2	Grid 3
<b>0.217</b>	<b>0.233</b>	<b>0.207</b>
Grid 4	Grid 5	Grid 6
<b>0.218</b>	<b>0.233</b>	<b>0.181</b>
Grid 7	Grid 8	Grid 9
<b>0.193</b>	<b>0.203</b>	<b>0.121</b>

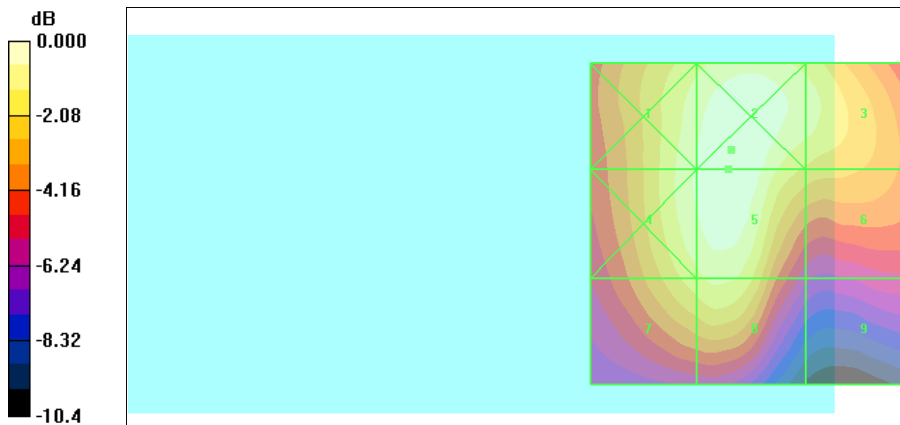

0 dB = 0.233A/m



Test Laboratory: A Test Lab Techno Corp.

Date/Time: 12/19/2006 10:42:58 AM

**HAC\_CDMA PCS CH1175\_Bluetooth CH39\_H**

**DUT: TITA100; Type:Pocket PC Phone; FCC ID:NM8TITA100**

Communication System: CDMA PCS ; Frequency: 1908.75 MHz;Duty Cycle: 1:1

Medium parameters used:  $\sigma = 0$  mho/m,  $\epsilon_r = 1$ ;  $\rho = 1$  kg/m<sup>3</sup>

Phantom section: H Device Section

Measurement Standard: DAS4 (High Precision Assessment)

DASY4 Configuration:

- Probe: H3DV6 - SN6076; ; Calibrated: 10/21/2005
- Sensor-Surface: (Fix Surface)
- Electronics: DAE3 Sn393; Calibrated: 9/5/2006
- Phantom: HAC Test Arch; Type: SD HAC P01 BA; Serial:
- Measurement SW: DAS4, V4.7 Build 44; Postprocessing SW: SEMCAD, V1.8 Build 171

**H Scan - H3DV6 probe center 10mm above Device Reference/Hearing Aid Compatibility Test (101x101x1):**

Measurement grid: dx=5mm, dy=5mm

Maximum value of peak Total field = 0.224 A/m

Probe Modulation Factor = 1.08

Reference Value = 0.196 A/m; Power Drift = -0.153 dB

**Hearing Aid Near-Field Category: M3 (AWF 0 dB)**

Peak H-field in A/m

Grid 1	Grid 2	Grid 3
<b>0.208</b>	<b>0.223</b>	<b>0.196</b>
Grid 4	Grid 5	Grid 6
<b>0.210</b>	<b>0.224</b>	<b>0.177</b>
Grid 7	Grid 8	Grid 9
<b>0.194</b>	<b>0.205</b>	<b>0.128</b>

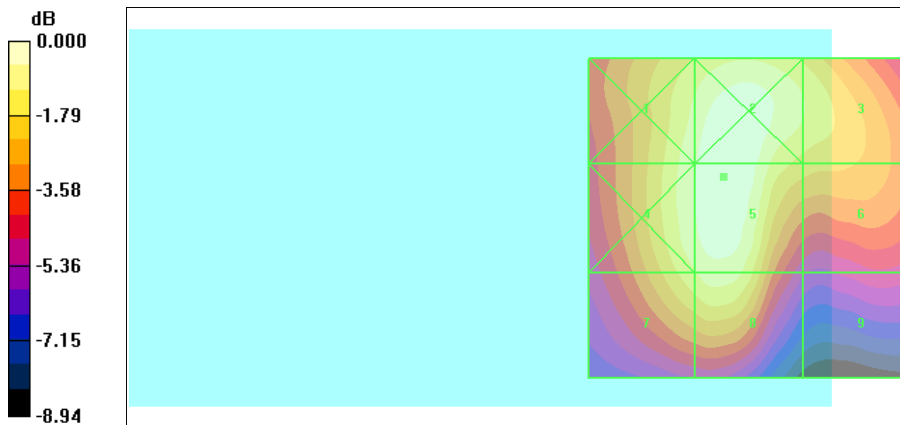

0 dB = 0.224A/m



A Test Lab Techno Corp.

Date/Time: 10/9/2006 7:57:31 PM

**802.11b CH1\_H**

**DUT: TTTA100; Type:Pocket PC Phone; FCC ID:NM8TITA100**

Communication System: IEEE 802.11b; Frequency: 2412 MHz;Duty Cycle: 1:1

Medium parameters used:  $\sigma = 0$  mho/m,  $\epsilon_r = 1$ ;  $\rho = 1$  kg/m<sup>3</sup>

Phantom section: E Device Section

Measurement Standard: DAS4 (High Precision Assessment)

DASY4 Configuration:

- Probe: H3DV6 - SN6076; ; Calibrated: 10/21/2005
- Sensor-Surface: (Fix Surface)
- Electronics: DAE3 Sn393; Calibrated: 9/5/2006
- Phantom: HAC Test Arch; Type: SD HAC P01 BA; Serial:
- Measurement SW: DASY4, V4.7 Build 44; Postprocessing SW: SEMCAD, V1.8 Build 171

**H Scan - H3DV6 probe center 10mm above Device Reference/Hearing Aid Compatibility Test (101x101x1):**

Measurement grid: dx=5mm, dy=5mm

Maximum value of peak Total field = 0.036 A/m

Probe Modulation Factor = 0.820

Reference Value = 0.039 A/m; Power Drift = -0.095 dB

**Hearing Aid Near-Field Category: M4 (AWF 0 dB)**

Peak H-field in A/m

Grid 1	Grid 2	Grid 3
<b>0.040</b>	<b>0.040</b>	<b>0.031</b>
Grid 4	Grid 5	Grid 6
<b>0.034</b>	<b>0.036</b>	<b>0.029</b>
Grid 7	Grid 8	Grid 9
<b>0.025</b>	<b>0.028</b>	<b>0.022</b>

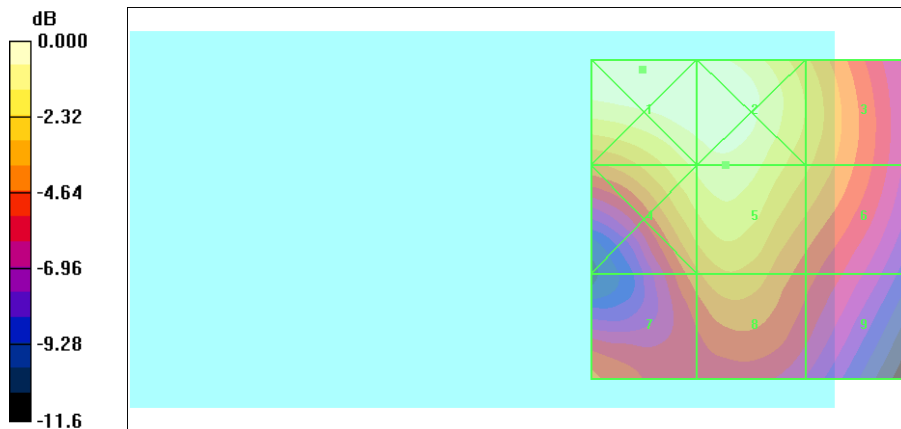

0 dB = 0.040A/m





A Test Lab Techno Corp.

Date/Time: 10/9/2006 8:35:00 PM

**802.11b CH6\_H**

**DUT: TTTA100; Type:Pocket PC Phone; FCC ID:NM8TTTA100**

Communication System: IEEE 802.11b; Frequency: 2437 MHz;Duty Cycle: 1:1

Medium parameters used:  $\sigma = 0$  mho/m,  $\epsilon_r = 1$ ;  $\rho = 1$  kg/m<sup>3</sup>

Phantom section: E Device Section

Measurement Standard: DAS4 (High Precision Assessment)

DASY4 Configuration:

- Probe: H3DV6 - SN6076; ; Calibrated: 10/21/2005
- Sensor-Surface: (Fix Surface)
- Electronics: DAE3 Sn393; Calibrated: 9/5/2006
- Phantom: HAC Test Arch; Type: SD HAC P01 BA; Serial:
- Measurement SW: DASY4, V4.7 Build 44; Postprocessing SW: SEMCAD, V1.8 Build 171

**H Scan - H3DV6 probe center 10mm above Device Reference/Hearing Aid Compatibility Test (101x101x1):**

Measurement grid: dx=5mm, dy=5mm

Maximum value of peak Total field = 0.036 A/m

Probe Modulation Factor = 0.820

Reference Value = 0.041 A/m; Power Drift = -0.110 dB

**Hearing Aid Near-Field Category: M4 (AWF 0 dB)**

Peak H-field in A/m

Grid 1	Grid 2	Grid 3
<b>0.039</b>	<b>0.038</b>	<b>0.029</b>
Grid 4	Grid 5	Grid 6
<b>0.035</b>	<b>0.036</b>	<b>0.028</b>
Grid 7	Grid 8	Grid 9
<b>0.028</b>	<b>0.030</b>	<b>0.025</b>

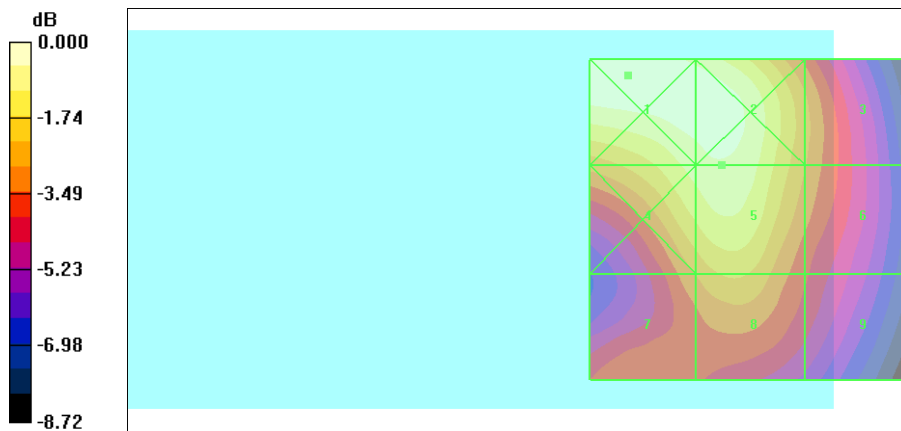

0 dB = 0.039A/m



A Test Lab Techno Corp.

Date/Time: 10/9/2006 8:54:15 PM

**802.11b CH11\_H**

**DUT: TTTA100; Type:Pocket PC Phone; FCC ID:NM8TITA100**

Communication System: IEEE 802.11b; Frequency: 2462 MHz;Duty Cycle: 1:1

Medium parameters used:  $\sigma = 0$  mho/m,  $\epsilon_r = 1$ ;  $\rho = 1$  kg/m<sup>3</sup>

Phantom section: E Device Section

Measurement Standard: DASYS4 (High Precision Assessment)

DASY4 Configuration:

- Probe: H3DV6 - SN6076; ; Calibrated: 10/21/2005
- Sensor-Surface: (Fix Surface)
- Electronics: DAE3 Sn393; Calibrated: 9/5/2006
- Phantom: HAC Test Arch; Type: SD HAC P01 BA; Serial:
- Measurement SW: DASY4, V4.7 Build 44; Postprocessing SW: SEMCAD, V1.8 Build 171

**H Scan - H3DV6 probe center 10mm above Device Reference/Hearing Aid Compatibility Test (101x101x1):**

Measurement grid: dx=5mm, dy=5mm

Maximum value of peak Total field = 0.035 A/m

Probe Modulation Factor = 0.820

Reference Value = 0.040 A/m; Power Drift = -0.097 dB

**Hearing Aid Near-Field Category: M4 (AWF 0 dB)**

Peak H-field in A/m

Grid 1	Grid 2	Grid 3
<b>0.036</b>	<b>0.036</b>	<b>0.028</b>
Grid 4	Grid 5	Grid 6
<b>0.034</b>	<b>0.035</b>	<b>0.028</b>
Grid 7	Grid 8	Grid 9
<b>0.028</b>	<b>0.030</b>	<b>0.027</b>

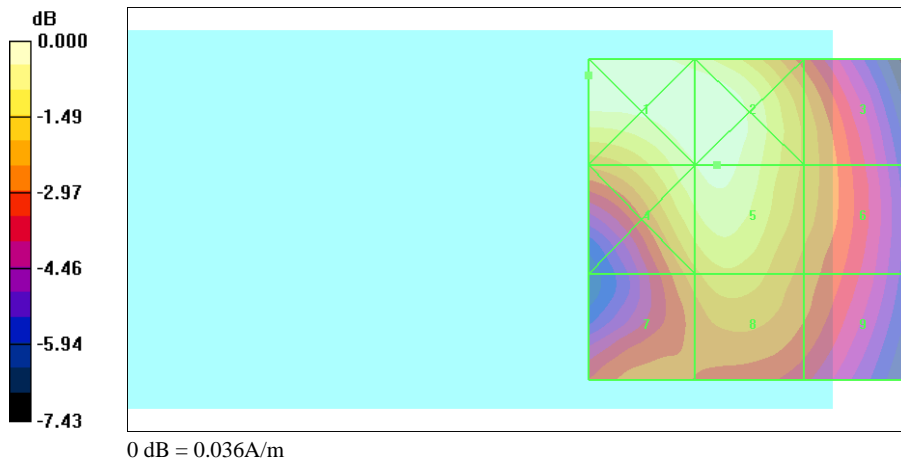



A Test Lab Techno Corp.

Date/Time: 10/9/2006 9:07:30 PM

**802.11g CH1\_H**

**DUT: TTTA100; Type:Pocket PC Phone; FCC ID:NM8TITA100**

Communication System: IEEE 802.11g; Frequency: 2412 MHz;Duty Cycle: 1:1

Medium parameters used:  $\sigma = 0$  mho/m,  $\epsilon_r = 1$ ;  $\rho = 1$  kg/m<sup>3</sup>

Phantom section: E Device Section

Measurement Standard: DASYS4 (High Precision Assessment)

DASY4 Configuration:

- Probe: H3DV6 - SN6076; ; Calibrated: 10/21/2005
- Sensor-Surface: (Fix Surface)
- Electronics: DAE3 Sn393; Calibrated: 9/5/2006
- Phantom: HAC Test Arch; Type: SD HAC P01 BA; Serial:
- Measurement SW: DASY4, V4.7 Build 44; Postprocessing SW: SEMCAD, V1.8 Build 171

**H Scan - H3DV6 probe center 10mm above Device Reference/Hearing Aid Compatibility Test (101x101x1):**

Measurement grid: dx=5mm, dy=5mm

Maximum value of peak Total field = 0.028 A/m

Probe Modulation Factor = 0.610

Reference Value = 0.040 A/m; Power Drift = -0.154 dB

**Hearing Aid Near-Field Category: M4 (AWF 0 dB)**

Peak H-field in A/m

Grid 1	Grid 2	Grid 3
<b>0.031</b>	<b>0.030</b>	<b>0.021</b>
Grid 4	Grid 5	Grid 6
<b>0.027</b>	<b>0.028</b>	<b>0.020</b>
Grid 7	Grid 8	Grid 9
<b>0.021</b>	<b>0.022</b>	<b>0.017</b>



0 dB = 0.031A/m



A Test Lab Techno Corp.

Date/Time: 10/9/2006 9:25:11 PM

**802.11g CH6\_H**

**DUT: TTTA100; Type:Pocket PC Phone; FCC ID:NM8TITA100**

Communication System: IEEE 802.11g; Frequency: 2437 MHz;Duty Cycle: 1:1

Medium parameters used:  $\sigma = 0$  mho/m,  $\epsilon_r = 1$ ;  $\rho = 1$  kg/m<sup>3</sup>

Phantom section: E Device Section

Measurement Standard: DASYS4 (High Precision Assessment)

DASY4 Configuration:

- Probe: H3DV6 - SN6076; ; Calibrated: 10/21/2005
- Sensor-Surface: (Fix Surface)
- Electronics: DAE3 Sn393; Calibrated: 9/5/2006
- Phantom: HAC Test Arch; Type: SD HAC P01 BA; Serial:
- Measurement SW: DASY4, V4.7 Build 44; Postprocessing SW: SEMCAD, V1.8 Build 171

**H Scan - H3DV6 probe center 10mm above Device Reference/Hearing Aid Compatibility Test (101x101x1):**

Measurement grid: dx=5mm, dy=5mm

Maximum value of peak Total field = 0.028 A/m

Probe Modulation Factor = 0.610

Reference Value = 0.042 A/m; Power Drift = -0.192 dB

**Hearing Aid Near-Field Category: M4 (AWF 0 dB)**

Peak H-field in A/m

Grid 1	Grid 2	Grid 3
<b>0.029</b>	<b>0.029</b>	<b>0.022</b>
Grid 4	Grid 5	Grid 6
<b>0.028</b>	<b>0.028</b>	<b>0.021</b>
Grid 7	Grid 8	Grid 9
<b>0.023</b>	<b>0.024</b>	<b>0.019</b>

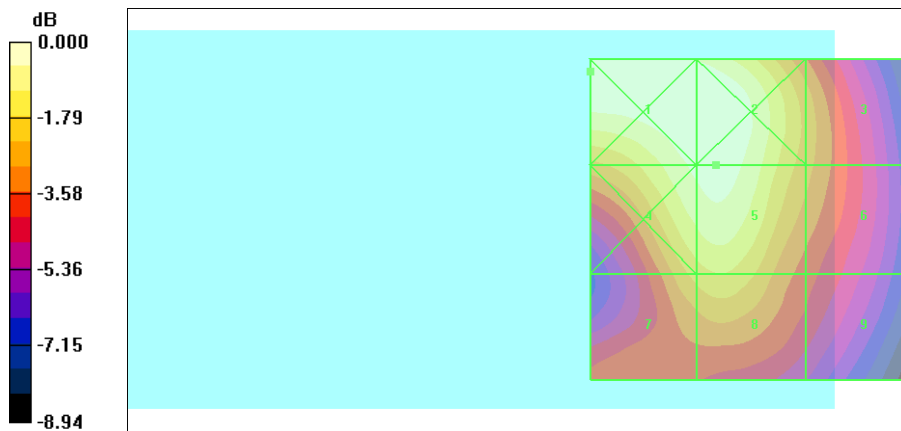

0 dB = 0.029A/m



A Test Lab Techno Corp.

Date/Time: 10/10/2006 12:38:19 AM

**802.11g CH11\_H**

**DUT: TTTA100; Type:Pocket PC Phone; FCC ID:NM8TITA100**

Communication System: IEEE 802.11g; Frequency: 2462 MHz;Duty Cycle: 1:1

Medium parameters used:  $\sigma = 0$  mho/m,  $\epsilon_r = 1$ ;  $\rho = 1$  kg/m<sup>3</sup>

Phantom section: E Device Section

Measurement Standard: DASYS4 (High Precision Assessment)

DASY4 Configuration:

- Probe: H3DV6 - SN6076; ; Calibrated: 10/21/2005
- Sensor-Surface: (Fix Surface)
- Electronics: DAE3 Sn393; Calibrated: 9/5/2006
- Phantom: HAC Test Arch; Type: SD HAC P01 BA; Serial:
- Measurement SW: DASY4, V4.7 Build 44; Postprocessing SW: SEMCAD, V1.8 Build 171

**H Scan - H3DV6 probe center 10mm above Device Reference/Hearing Aid Compatibility Test (101x101x1):**

Measurement grid: dx=5mm, dy=5mm

Maximum value of peak Total field = 0.026 A/m

Probe Modulation Factor = 0.610

Reference Value = 0.037 A/m; Power Drift = -0.040 dB

**Hearing Aid Near-Field Category: M4 (AWF 0 dB)**

Peak H-field in A/m

Grid 1	Grid 2	Grid 3
<b>0.026</b>	<b>0.027</b>	<b>0.020</b>
Grid 4	Grid 5	Grid 6
<b>0.026</b>	<b>0.026</b>	<b>0.020</b>
Grid 7	Grid 8	Grid 9
<b>0.019</b>	<b>0.020</b>	<b>0.017</b>

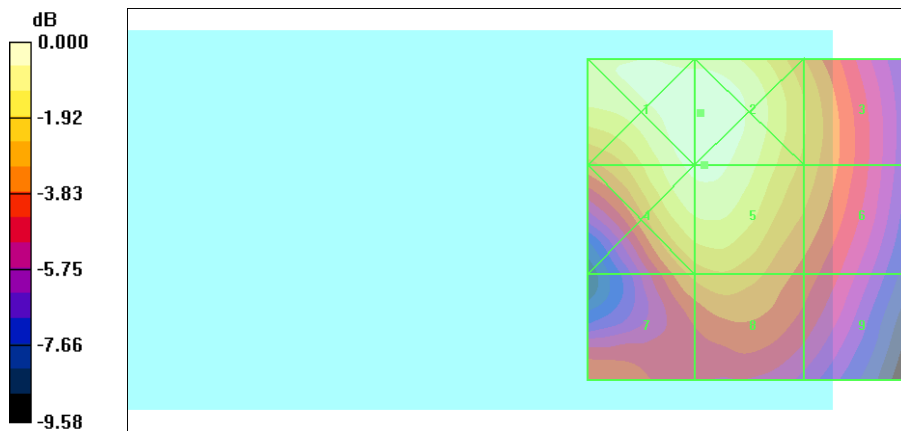

0 dB = 0.027A/m



***Appendix D - TITA100 – Mode 2 HAC distribution plots for E-Field and H-Field***

See following Attached Pages for HAC distribution plots for E-Field and H-Field.



Test Laboratory: A Test Lab Techno Corp.

Date/Time: 10/21/2006 12:14:55 PM

**CDMA 850 CH1013\_E**

**DUT: TTTA200; Type:Pocket PC Phone; FCC ID:NM8TITA100**

Communication System: CDMA; Frequency: 824.7 MHz;Duty Cycle: 1:1

Medium parameters used:  $\sigma = 0$  mho/m,  $\epsilon_r = 1$ ;  $\rho = 1000$  kg/m<sup>3</sup>

Phantom section: E Device Section

Measurement Standard: DAS4 (High Precision Assessment)

DAS4 Configuration:

- Probe: ER3DV6 - SN2256; ConvF(1, 1, 1); Calibrated: 10/21/2005
- Sensor-Surface: (Fix Surface)
- Electronics: DAE3 Sn393; Calibrated: 9/5/2006
- Phantom: HAC Test Arch; Type: SD HAC P01 BA; Serial:
- Measurement SW: DAS4, V4.7 Build 44; Postprocessing SW: SEMCAD, V1.8 Build 171

**E Scan - ER3DV6 probe center 10mm above Device Reference/Hearing Aid Compatibility Test (101x101x1):**

Measurement grid: dx=5mm, dy=5mm

Maximum value of peak Total field = 155.8 V/m

Probe Modulation Factor = 1.33

Reference Value = 105.3 V/m; Power Drift = 0.074 dB

**Hearing Aid Near-Field Category: M4 (AWF 0 dB)**

Peak E-field in V/m

Grid 1	Grid 2	Grid 3
<b>76.6</b>	<b>120.3</b>	<b>120.2</b>
Grid 4	Grid 5	Grid 6
<b>92.9</b>	<b>155.8</b>	<b>153.6</b>
Grid 7	Grid 8	Grid 9
<b>101.4</b>	<b>156.4</b>	<b>152.7</b>

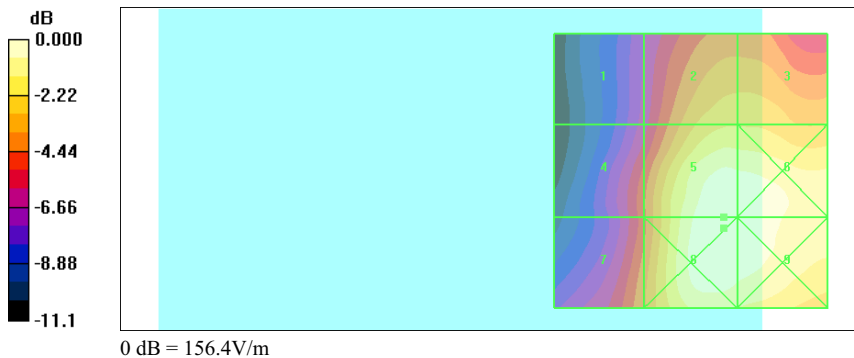



Test Laboratory: A Test Lab Techno Corp.

Date/Time: 10/21/2006 12:01:14 PM

**CDMA 850 CH384\_E**

**DUT: TTTA200; Type:Pocket PC Phone; FCC ID:NM8TITA100**

Communication System: CDMA; Frequency: 836.52 MHz;Duty Cycle: 1:1

Medium parameters used:  $\sigma = 0$  mho/m,  $\epsilon_r = 1$ ;  $\rho = 1000$  kg/m<sup>3</sup>

Phantom section: E Device Section

Measurement Standard: DASYS4 (High Precision Assessment)

DASY4 Configuration:

- Probe: ER3DV6 - SN2256; ConvF(1, 1, 1); Calibrated: 10/21/2005
- Sensor-Surface: (Fix Surface)
- Electronics: DAE3 Sn393; Calibrated: 9/5/2006
- Phantom: HAC Test Arch; Type: SD HAC P01 BA; Serial:
- Measurement SW: DASYS4, V4.7 Build 44; Postprocessing SW: SEMCAD, V1.8 Build 171

**E Scan - ER3DV6 probe center 10mm above Device Reference/Hearing Aid Compatibility Test (101x101x1):**

Measurement grid: dx=5mm, dy=5mm

Maximum value of peak Total field = 170.9 V/m

Probe Modulation Factor = 1.33

Reference Value = 116.8 V/m; Power Drift = 0.077 dB

**Hearing Aid Near-Field Category: M4 (AWF 0 dB)**

Peak E-field in V/m

Grid 1	Grid 2	Grid 3
<b>86.7</b>	<b>133.9</b>	<b>133.0</b>
Grid 4	Grid 5	Grid 6
<b>104.0</b>	<b>170.9</b>	<b>168.4</b>
Grid 7	Grid 8	Grid 9
<b>112.9</b>	<b>173.4</b>	<b>168.0</b>

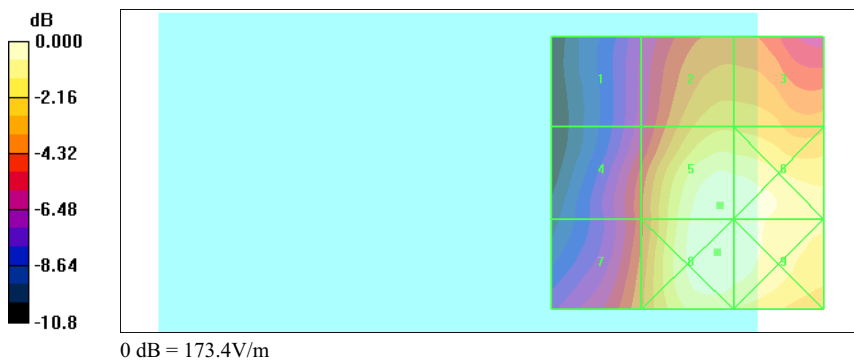





Test Laboratory: A Test Lab Techno Corp.

Date/Time: 10/21/2006 12:07:14 PM

**CDMA 850 CH777\_E**

**DUT: TTTA200; Type:Pocket PC Phone; FCC ID:NM8TITA100**

Communication System: CDMA; Frequency: 848.31 MHz;Duty Cycle: 1:1

Medium parameters used:  $\sigma = 0$  mho/m,  $\epsilon_r = 1$ ;  $\rho = 1000$  kg/m<sup>3</sup>

Phantom section: E Device Section

Measurement Standard: DASYS4 (High Precision Assessment)

DASY4 Configuration:

- Probe: ER3DV6 - SN2256; ConvF(1, 1, 1); Calibrated: 10/21/2005
- Sensor-Surface: (Fix Surface)
- Electronics: DAE3 Sn393; Calibrated: 9/5/2006
- Phantom: HAC Test Arch; Type: SD HAC P01 BA; Serial:
- Measurement SW: DASYS4, V4.7 Build 44; Postprocessing SW: SEMCAD, V1.8 Build 171

**E Scan - ER3DV6 probe center 10mm above Device Reference/Hearing Aid Compatibility Test (101x101x1):**

Measurement grid: dx=5mm, dy=5mm

Maximum value of peak Total field = 143.3 V/m

Probe Modulation Factor = 1.33

Reference Value = 99.0 V/m; Power Drift = 0.023 dB

**Hearing Aid Near-Field Category: M4 (AWF 0 dB)**

Peak E-field in V/m

Grid 1	Grid 2	Grid 3
<b>74.7</b>	<b>111.4</b>	<b>111.0</b>
Grid 4	Grid 5	Grid 6
<b>89.9</b>	<b>143.3</b>	<b>140.6</b>
Grid 7	Grid 8	Grid 9
<b>97.7</b>	<b>145.6</b>	<b>139.9</b>

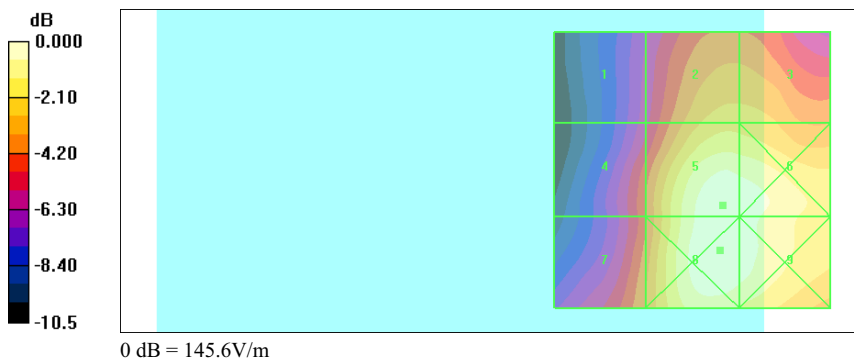



Test Laboratory: A Test Lab Techno Corp.

Date/Time: 10/21/2006 11:37:15 AM

**CDMA 1900 CH25\_E**

**DUT: TTTA200; Type:Pocket PC Phone; FCC ID:NM8TITA100**

Communication System: PCS 1900; Frequency: 1851.25 MHz;Duty Cycle: 1:1

Medium parameters used:  $\sigma = 0$  mho/m,  $\epsilon_r = 1$ ;  $\rho = 1000$  kg/m<sup>3</sup>

Phantom section: E Device Section

Measurement Standard: DAS4 (High Precision Assessment)

DASY4 Configuration:

- Probe: ER3DV6 - SN2256; ConvF(1, 1, 1); Calibrated: 10/21/2005
- Sensor-Surface: (Fix Surface)
- Electronics: DAE3 Sn393; Calibrated: 9/5/2006
- Phantom: HAC Test Arch; Type: SD HAC P01 BA; Serial:
- Measurement SW: DAS4, V4.7 Build 44; Postprocessing SW: SEMCAD, V1.8 Build 171

**E Scan - ER3DV6 probe center 10mm above Device Reference/Hearing Aid Compatibility Test (101x101x1):**

Measurement grid: dx=5mm, dy=5mm

Maximum value of peak Total field = 65.9 V/m

Probe Modulation Factor = 1.06

Reference Value = 45.8 V/m; Power Drift = -0.025 dB

**Hearing Aid Near-Field Category: M3 (AWF 0 dB)**

Peak E-field in V/m

Grid 1	Grid 2	Grid 3
49.7	65.9	64.7
Grid 4	Grid 5	Grid 6
43.7	58.9	55.3
Grid 7	Grid 8	Grid 9
72.6	81.8	70.7

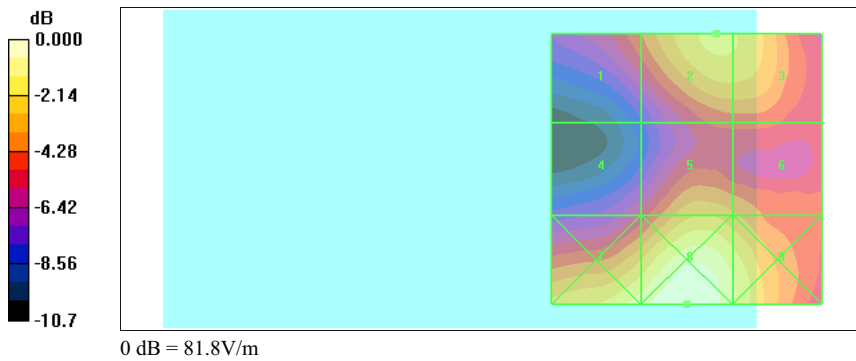



Test Laboratory: A Test Lab Techno Corp.

Date/Time: 10/21/2006 11:44:52 AM

**CDMA 1900 CH600\_E**

**DUT: TTTA200; Type:Pocket PC Phone; FCC ID:NM8TITA100**

Communication System: PCS 1900; Frequency: 1880 MHz;Duty Cycle: 1:1

Medium parameters used:  $\sigma = 0$  mho/m,  $\epsilon_r = 1$ ;  $\rho = 1000$  kg/m<sup>3</sup>

Phantom section: E Device Section

Measurement Standard: DAS4 (High Precision Assessment)

DAS4 Configuration:

- Probe: ER3DV6 - SN2256; ConvF(1, 1, 1); Calibrated: 10/21/2005
- Sensor-Surface: (Fix Surface)
- Electronics: DAE3 Sn393; Calibrated: 9/5/2006
- Phantom: HAC Test Arch; Type: SD HAC P01 BA; Serial:
- Measurement SW: DAS4, V4.7 Build 44; Postprocessing SW: SEMCAD, V1.8 Build 171

**E Scan - ER3DV6 probe center 10mm above Device Reference/Hearing Aid Compatibility Test (101x101x1):**

Measurement grid: dx=5mm, dy=5mm

Maximum value of peak Total field = 70.9 V/m

Probe Modulation Factor = 1.06

Reference Value = 47.5 V/m; Power Drift = 0.071 dB

**Hearing Aid Near-Field Category: M3 (AWF 0 dB)**

Peak E-field in V/m

Grid 1	Grid 2	Grid 3
<b>54.3</b>	<b>70.9</b>	<b>69.8</b>
Grid 4	Grid 5	Grid 6
<b>44.6</b>	<b>60.7</b>	<b>57.4</b>
Grid 7	Grid 8	Grid 9
<b>74.3</b>	<b>83.5</b>	<b>74.0</b>

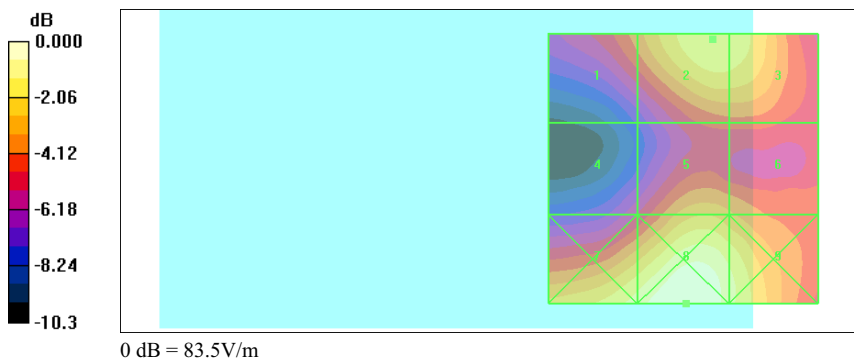



Test Laboratory: A Test Lab Techno Corp.

Date/Time: 10/21/2006 11:52:48 AM

**CDMA 1900 CH1175\_E**

**DUT: TTTA200; Type:Pocket PC Phone; FCC ID:NM8TITA100**

Communication System: PCS 1900; Frequency: 1908.75 MHz;Duty Cycle: 1:1

Medium parameters used:  $\sigma = 0$  mho/m,  $\epsilon_r = 1$ ;  $\rho = 1000$  kg/m<sup>3</sup>

Phantom section: E Device Section

Measurement Standard: DAS4 (High Precision Assessment)

DAS4 Configuration:

- Probe: ER3DV6 - SN2256; ConvF(1, 1, 1); Calibrated: 10/21/2005
- Sensor-Surface: (Fix Surface)
- Electronics: DAE3 Sn393; Calibrated: 9/5/2006
- Phantom: HAC Test Arch; Type: SD HAC P01 BA; Serial:
- Measurement SW: DAS4, V4.7 Build 44; Postprocessing SW: SEMCAD, V1.8 Build 171

**E Scan - ER3DV6 probe center 10mm above Device Reference/Hearing Aid Compatibility Test (101x101x1):**

Measurement grid: dx=5mm, dy=5mm

Maximum value of peak Total field = 74.8 V/m

Probe Modulation Factor = 1.06

Reference Value = 46.9 V/m; Power Drift = -0.024 dB

**Hearing Aid Near-Field Category: M3 (AWF 0 dB)**

Peak E-field in V/m

Grid 1	Grid 2	Grid 3
<b>58.6</b>	<b>74.8</b>	<b>73.5</b>
Grid 4	Grid 5	Grid 6
<b>44.0</b>	<b>59.7</b>	<b>56.8</b>
Grid 7	Grid 8	Grid 9
<b>75.1</b>	<b>85.1</b>	<b>74.8</b>

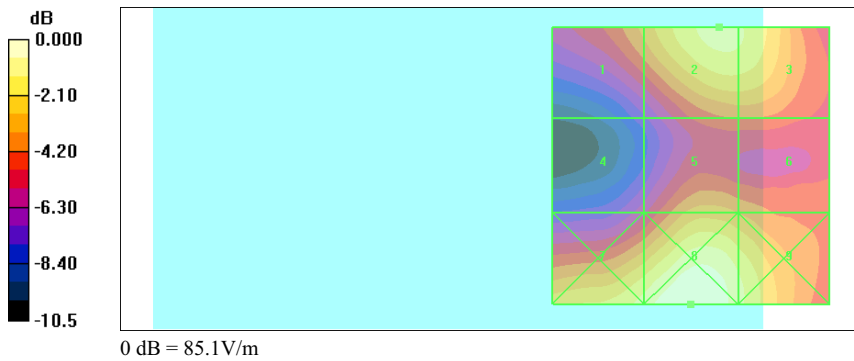



Test Laboratory: A Test Lab Techno Corp. Date/Time: 12/26/2006 11:42:00 PM

**HAC\_CDMA Cellular CH1013\_802.11b CH1\_E**

**DUT: TTTA200; Type:Pocket PC Phone; FCC ID:NM8TITA100**

Communication System: CDMA Cellular ; Frequency: 824.7 MHz;Duty Cycle: 1:1

Medium parameters used:  $\sigma = 0$  mho/m,  $\epsilon_r = 1$ ;  $\rho = 1000$  kg/m<sup>3</sup>

Phantom section: E Device Section

Measurement Standard: DAS4 (High Precision Assessment)

DASY4 Configuration:

- Probe: ER3DV6 - SN2256; ConvF(1, 1, 1); Calibrated: 10/21/2005
- Sensor-Surface: (Fix Surface)
- Electronics: DAE4 Sn541; Calibrated: 10/16/2006
- Phantom: HAC Test Arch; Type: SD HAC P01 BA; Serial:
- Measurement SW: DAS4, V4.7 Build 44; Postprocessing SW: SEMCAD, V1.8 Build 171

**E Scan - ER3DV6 probe center 10mm above Device Reference/Hearing Aid Compatibility Test (101x101x1):**

Measurement grid: dx=5mm, dy=5mm

Maximum value of peak Total field = 148.4 V/m

Probe Modulation Factor = 1.33

Reference Value = 102.6 V/m; Power Drift = -0.046 dB

**Hearing Aid Near-Field Category: M4 (AWF 0 dB)**

Peak E-field in V/m

Grid 1	Grid 2	Grid 3
<b>62.9</b>	<b>104.0</b>	<b>102.6</b>
Grid 4	Grid 5	Grid 6
<b>90.3</b>	<b>148.4</b>	<b>142.8</b>
Grid 7	Grid 8	Grid 9
<b>106.0</b>	<b>150.2</b>	<b>142.5</b>

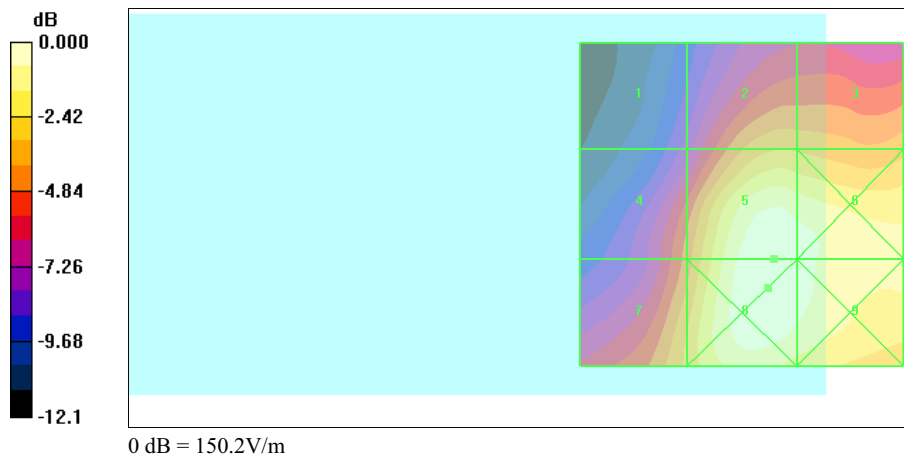



Test Laboratory: A Test Lab Techno Corp. Date/Time: 12/26/2006 11:34:34 PM

**HAC\_CDMA Cellular CH384\_802.11b CH1\_E**

**DUT: TTTA200; Type:Pocket PC Phone; FCC ID:NM8TITA100**

Communication System: CDMA Cellular ; Frequency: 836.52 MHz;Duty Cycle: 1:1

Medium parameters used:  $\sigma = 0$  mho/m,  $\epsilon_r = 1$ ;  $\rho = 1000$  kg/m<sup>3</sup>

Phantom section: E Device Section

Measurement Standard: DASYS4 (High Precision Assessment)

DASY4 Configuration:

- Probe: ER3DV6 - SN2256; ConvF(1, 1, 1); Calibrated: 10/21/2005
- Sensor-Surface: (Fix Surface)
- Electronics: DAE4 Sn541; Calibrated: 10/16/2006
- Phantom: HAC Test Arch; Type: SD HAC P01 BA; Serial:
- Measurement SW: DASYS4, V4.7 Build 44; Postprocessing SW: SEMCAD, V1.8 Build 171

**E Scan - ER3DV6 probe center 10mm above Device Reference/Hearing Aid Compatibility Test (101x101x1):**

Measurement grid: dx=5mm, dy=5mm

Maximum value of peak Total field = 168.3 V/m

Probe Modulation Factor = 1.33

Reference Value = 114.6 V/m; Power Drift = 0.131 dB

**Hearing Aid Near-Field Category: M4 (AWF 0 dB)**

Peak E-field in V/m

Grid 1	Grid 2	Grid 3
<b>72.0</b>	<b>117.0</b>	<b>116.4</b>
Grid 4	Grid 5	Grid 6
<b>101.6</b>	<b>168.3</b>	<b>162.3</b>
Grid 7	Grid 8	Grid 9
<b>119.1</b>	<b>171.0</b>	<b>162.7</b>

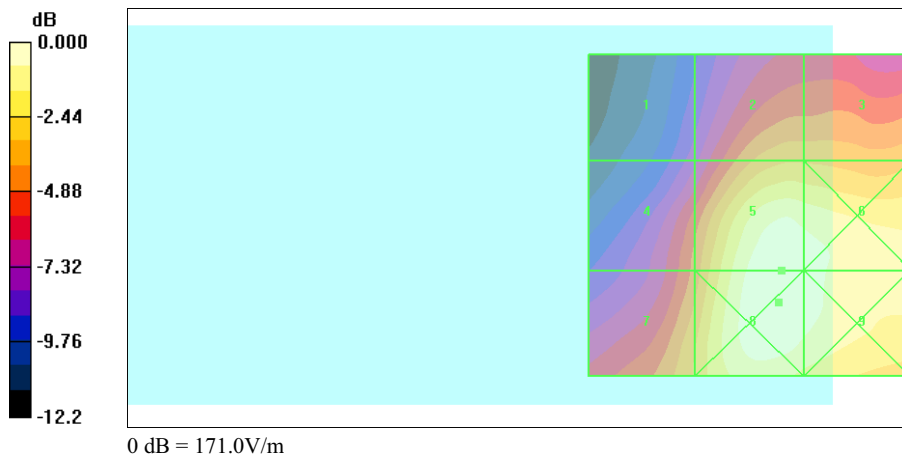



Test Laboratory: A Test Lab Techno Corp. Date/Time: 12/26/2006 11:29:06 PM

**HAC\_CDMA Cellular CH777\_802.11b CH1\_E**

**DUT: TTTA200; Type:Pocket PC Phone; FCC ID:NM8TITA100**

Communication System: CDMA Cellular ; Frequency: 848.31 MHz;Duty Cycle: 1:1

Medium parameters used:  $\sigma = 0$  mho/m,  $\epsilon_r = 1$ ;  $\rho = 1000$  kg/m<sup>3</sup>

Phantom section: E Device Section

Measurement Standard: DASYS4 (High Precision Assessment)

DASY4 Configuration:

- Probe: ER3DV6 - SN2256; ConvF(1, 1, 1); Calibrated: 10/21/2005
- Sensor-Surface: (Fix Surface)
- Electronics: DAE4 Sn541; Calibrated: 10/16/2006
- Phantom: HAC Test Arch; Type: SD HAC P01 BA; Serial:
- Measurement SW: DASYS4, V4.7 Build 44; Postprocessing SW: SEMCAD, V1.8 Build 171

**E Scan - ER3DV6 probe center 10mm above Device Reference/Hearing Aid Compatibility Test (101x101x1):**

Measurement grid: dx=5mm, dy=5mm

Maximum value of peak Total field = 146.9 V/m

Probe Modulation Factor = 1.33

Reference Value = 101.4 V/m; Power Drift = -0.130 dB

**Hearing Aid Near-Field Category: M4 (AWF 0 dB)**

Peak E-field in V/m

Grid 1	Grid 2	Grid 3
<b>65.4</b>	<b>102.1</b>	<b>101.1</b>
Grid 4	Grid 5	Grid 6
<b>91.4</b>	<b>146.9</b>	<b>140.7</b>
Grid 7	Grid 8	Grid 9
<b>108.6</b>	<b>149.1</b>	<b>141.6</b>

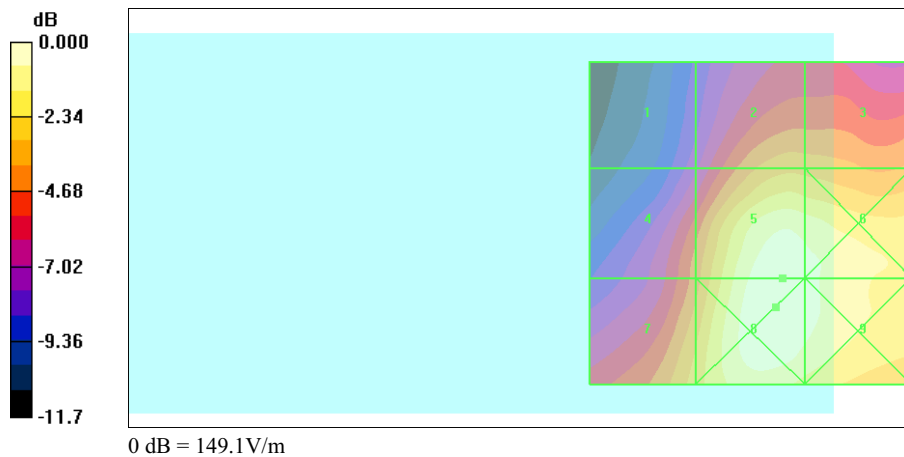



Test Laboratory: A Test Lab Techno Corp. Date/Time: 12/26/2006 11:48:29 PM

**HAC\_CDMA PCS CH25\_802.11b CH1\_E**

**DUT: TTTA200; Type:Pocket PC Phone; FCC ID:NM8TITA100**

Communication System: CDMA PCS ; Frequency: 1851.25 MHz;Duty Cycle: 1:1

Medium parameters used:  $\sigma = 0$  mho/m,  $\epsilon_r = 1$ ;  $\rho = 1000$  kg/m<sup>3</sup>

Phantom section: E Device Section

Measurement Standard: DASYS4 (High Precision Assessment)

DASY4 Configuration:

- Probe: ER3DV6 - SN2256; ConvF(1, 1, 1); Calibrated: 10/21/2005
- Sensor-Surface: (Fix Surface)
- Electronics: DAE4 Sn541; Calibrated: 10/16/2006
- Phantom: HAC Test Arch; Type: SD HAC P01 BA; Serial:
- Measurement SW: DASYS4, V4.7 Build 44; Postprocessing SW: SEMCAD, V1.8 Build 171

**E Scan - ER3DV6 probe center 10mm above Device Reference/Hearing Aid Compatibility Test (101x101x1):**

Measurement grid: dx=5mm, dy=5mm

Maximum value of peak Total field = 67.5 V/m

Probe Modulation Factor = 1.06

Reference Value = 52.1 V/m; Power Drift = 0.162 dB

**Hearing Aid Near-Field Category: M3 (AWF 0 dB)**

Peak E-field in V/m

Grid 1	Grid 2	Grid 3
<b>50.7</b>	<b>66.8</b>	<b>66.4</b>
Grid 4	Grid 5	Grid 6
<b>49.8</b>	<b>67.5</b>	<b>63.6</b>
Grid 7	Grid 8	Grid 9
<b>74.6</b>	<b>87.1</b>	<b>78.6</b>

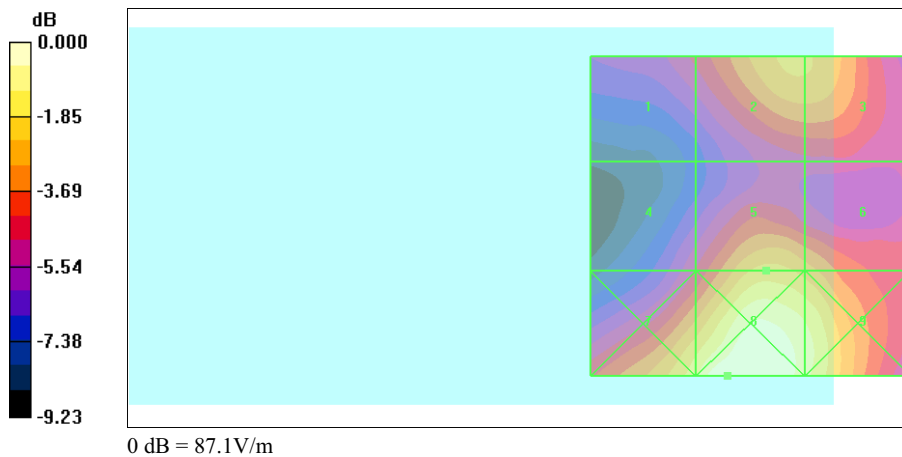





Test Laboratory: A Test Lab Techno Corp. Date/Time: 12/26/2006 11:53:50 PM

**HAC\_CDMA PCS CH600\_802.11b CH1\_E**

**DUT: TTTA200; Type:Pocket PC Phone; FCC ID:NM8TITA100**

Communication System: CDMA PCS ; Frequency: 1880 MHz;Duty Cycle: 1:1

Medium parameters used:  $\sigma = 0$  mho/m,  $\epsilon_r = 1$ ;  $\rho = 1000$  kg/m<sup>3</sup>

Phantom section: E Device Section

Measurement Standard: DASYS4 (High Precision Assessment)

DASY4 Configuration:

- Probe: ER3DV6 - SN2256; ConvF(1, 1, 1); Calibrated: 10/21/2005
- Sensor-Surface: (Fix Surface)
- Electronics: DAE4 Sn541; Calibrated: 10/16/2006
- Phantom: HAC Test Arch; Type: SD HAC P01 BA; Serial:
- Measurement SW: DASYS4, V4.7 Build 44; Postprocessing SW: SEMCAD, V1.8 Build 171

**E Scan - ER3DV6 probe center 10mm above Device Reference/Hearing Aid Compatibility Test (101x101x1):**

Measurement grid: dx=5mm, dy=5mm

Maximum value of peak Total field = 75.6 V/m

Probe Modulation Factor = 1.06

Reference Value = 55.5 V/m; Power Drift = 0.134 dB

**Hearing Aid Near-Field Category: M3 (AWF 0 dB)**

Peak E-field in V/m

Grid 1	Grid 2	Grid 3
<b>55.2</b>	<b>75.6</b>	<b>75.1</b>
Grid 4	Grid 5	Grid 6
<b>57.4</b>	<b>73.3</b>	<b>66.7</b>
Grid 7	Grid 8	Grid 9
<b>91.6</b>	<b>101.6</b>	<b>85.6</b>

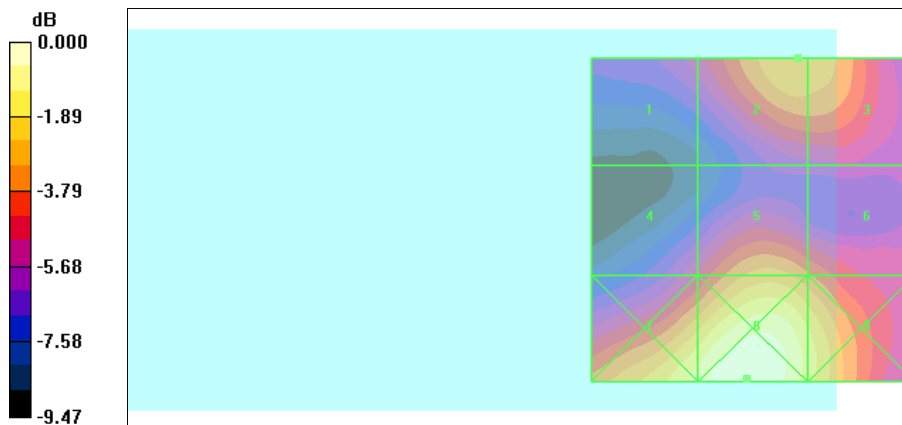

0 dB = 101.6V/m



Test Laboratory: A Test Lab Techno Corp. Date/Time: 12/26/2006 11:59:18 PM

**HAC\_CDMA PCS CH1175\_802.11b CH1\_E**

**DUT:TTTA200; Type:Pocket PC Phone; FCC ID:NM8TITA100**

Communication System: CDMA PCS ; Frequency: 1908.75 MHz;Duty Cycle: 1:1

Medium parameters used:  $\sigma = 0$  mho/m,  $\epsilon_r = 1$ ;  $\rho = 1000$  kg/m<sup>3</sup>

Phantom section: E Device Section

Measurement Standard: DASYS4 (High Precision Assessment)

DASY4 Configuration:

- Probe: ER3DV6 - SN2256; ConvF(1, 1, 1); Calibrated: 10/21/2005
- Sensor-Surface: (Fix Surface)
- Electronics: DAE4 Sn541; Calibrated: 10/16/2006
- Phantom: HAC Test Arch; Type: SD HAC P01 BA; Serial:
- Measurement SW: DASYS4, V4.7 Build 44; Postprocessing SW: SEMCAD, V1.8 Build 171

**E Scan - ER3DV6 probe center 10mm above Device Reference/Hearing Aid Compatibility Test (101x101x1):**

Measurement grid: dx=5mm, dy=5mm

Maximum value of peak Total field = 78.0 V/m

Probe Modulation Factor = 1.06

Reference Value = 50.9 V/m; Power Drift = -0.031 dB

**Hearing Aid Near-Field Category: M3 (AWF 0 dB)**

Peak E-field in V/m

Grid 1	Grid 2	Grid 3
<b>56.7</b>	<b>78.0</b>	<b>77.3</b>
Grid 4	Grid 5	Grid 6
<b>53.4</b>	<b>68.0</b>	<b>62.6</b>
Grid 7	Grid 8	Grid 9
<b>89.3</b>	<b>98.3</b>	<b>82.9</b>

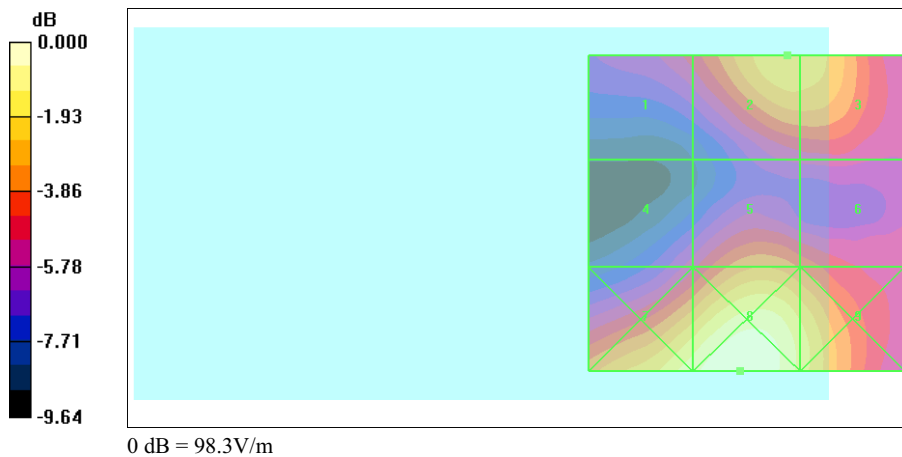



Test Laboratory: A Test Lab Techno Corp. Date/Time: 12/26/2006 11:06:28 PM

**HAC\_CDMA Cellular CH1013\_802.11g CH6\_E**

**DUT: TTTA200; Type:Pocket PC Phone; FCC ID:NM8TITA100**

Communication System: CDMA Cellular ; Frequency: 824.7 MHz;Duty Cycle: 1:1

Medium parameters used:  $\sigma = 0$  mho/m,  $\epsilon_r = 1$ ;  $\rho = 1000$  kg/m<sup>3</sup>

Phantom section: E Device Section

Measurement Standard: DASYS4 (High Precision Assessment)

DASY4 Configuration:

- Probe: ER3DV6 - SN2256; ConvF(1, 1, 1); Calibrated: 10/21/2005
- Sensor-Surface: (Fix Surface)
- Electronics: DAE4 Sn541; Calibrated: 10/16/2006
- Phantom: HAC Test Arch; Type: SD HAC P01 BA; Serial:
- Measurement SW: DASYS4, V4.7 Build 44; Postprocessing SW: SEMCAD, V1.8 Build 171

**E Scan - ER3DV6 probe center 10mm above Device Reference/Hearing Aid Compatibility Test (101x101x1):**

Measurement grid: dx=5mm, dy=5mm

Maximum value of peak Total field = 150.9 V/m

Probe Modulation Factor = 1.33

Reference Value = 107.7 V/m; Power Drift = -0.022 dB

**Hearing Aid Near-Field Category: M4 (AWF 0 dB)**

Peak E-field in V/m

Grid 1	Grid 2	Grid 3
<b>64.5</b>	<b>105.3</b>	<b>104.3</b>
Grid 4	Grid 5	Grid 6
<b>92.2</b>	<b>150.9</b>	<b>145.0</b>
Grid 7	Grid 8	Grid 9
<b>109.0</b>	<b>152.9</b>	<b>144.8</b>

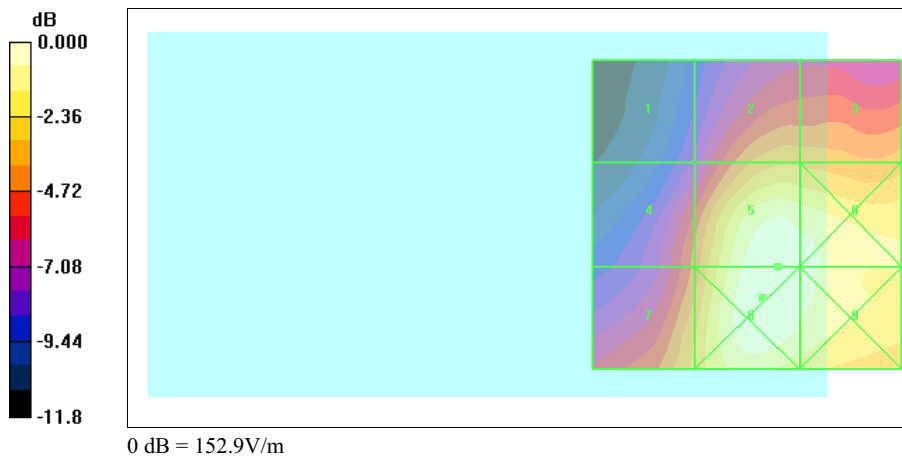



Test Laboratory: A Test Lab Techno Corp. Date/Time: 12/26/2006 11:11:49 PM

**HAC\_CDMA Cellular CH384\_802.11g CH6\_E**

**DUT: TTTA200; Type:Pocket PC Phone; FCC ID:NM8TITA100**

Communication System: CDMA Cellular ; Frequency: 836.52 MHz;Duty Cycle: 1:1

Medium parameters used:  $\sigma = 0$  mho/m,  $\epsilon_r = 1$ ;  $\rho = 1000$  kg/m<sup>3</sup>

Phantom section: E Device Section

Measurement Standard: DASYS4 (High Precision Assessment)

DASY4 Configuration:

- Probe: ER3DV6 - SN2256; ConvF(1, 1, 1); Calibrated: 10/21/2005
- Sensor-Surface: (Fix Surface)
- Electronics: DAE4 Sn541; Calibrated: 10/16/2006
- Phantom: HAC Test Arch; Type: SD HAC P01 BA; Serial:
- Measurement SW: DASYS4, V4.7 Build 44; Postprocessing SW: SEMCAD, V1.8 Build 171

**E Scan - ER3DV6 probe center 10mm above Device Reference/Hearing Aid Compatibility Test (101x101x1):**

Measurement grid: dx=5mm, dy=5mm

Maximum value of peak Total field = 169.3 V/m

Probe Modulation Factor = 1.33

Reference Value = 117.5 V/m; Power Drift = -0.071 dB

**Hearing Aid Near-Field Category: M4 (AWF 0 dB)**

Peak E-field in V/m

Grid 1	Grid 2	Grid 3
<b>72.7</b>	<b>117.1</b>	<b>116.3</b>
Grid 4	Grid 5	Grid 6
<b>103.4</b>	<b>169.3</b>	<b>163.0</b>
Grid 7	Grid 8	Grid 9
<b>122.4</b>	<b>170.8</b>	<b>163.0</b>

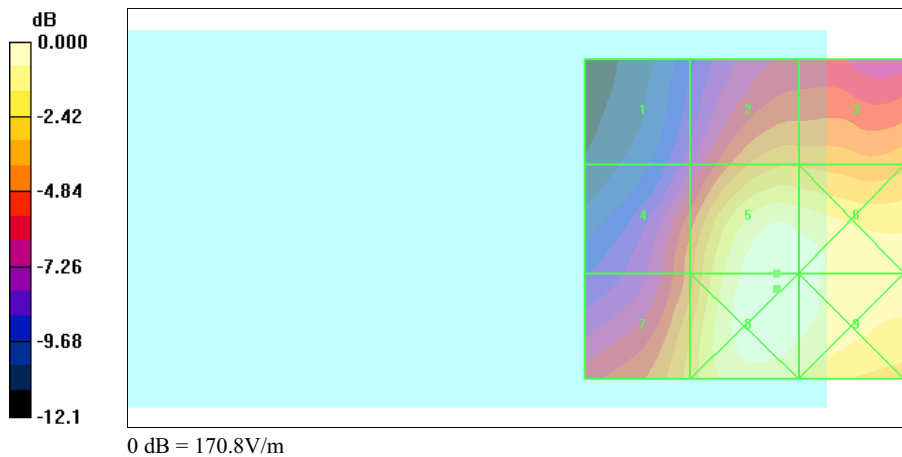



Test Laboratory: A Test Lab Techno Corp. Date/Time: 12/26/2006 11:17:16 PM

**HAC\_CDMA Cellular CH777\_802.11g CH6\_E**

**DUT:TTTA200; Type:Pocket PC Phone; FCC ID:NM8TITA100**

Communication System: CDMA Cellular ; Frequency: 848.31 MHz;Duty Cycle: 1:1

Medium parameters used:  $\sigma = 0$  mho/m,  $\epsilon_r = 1$ ;  $\rho = 1000$  kg/m<sup>3</sup>

Phantom section: E Device Section

Measurement Standard: DASYS4 (High Precision Assessment)

DASY4 Configuration:

- Probe: ER3DV6 - SN2256; ConvF(1, 1, 1); Calibrated: 10/21/2005
- Sensor-Surface: (Fix Surface)
- Electronics: DAE4 Sn541; Calibrated: 10/16/2006
- Phantom: HAC Test Arch; Type: SD HAC P01 BA; Serial:
- Measurement SW: DASYS4, V4.7 Build 44; Postprocessing SW: SEMCAD, V1.8 Build 171

**E Scan - ER3DV6 probe center 10mm above Device Reference/Hearing Aid Compatibility Test (101x101x1):**

Measurement grid: dx=5mm, dy=5mm

Maximum value of peak Total field = 144.7 V/m

Probe Modulation Factor = 1.33

Reference Value = 99.7 V/m; Power Drift = -0.021 dB

**Hearing Aid Near-Field Category: M4 (AWF 0 dB)**

Peak E-field in V/m

Grid 1	Grid 2	Grid 3
<b>63.5</b>	<b>100.9</b>	<b>100.5</b>
Grid 4	Grid 5	Grid 6
<b>89.1</b>	<b>144.7</b>	<b>139.9</b>
Grid 7	Grid 8	Grid 9
<b>104.9</b>	<b>147.8</b>	<b>140.3</b>

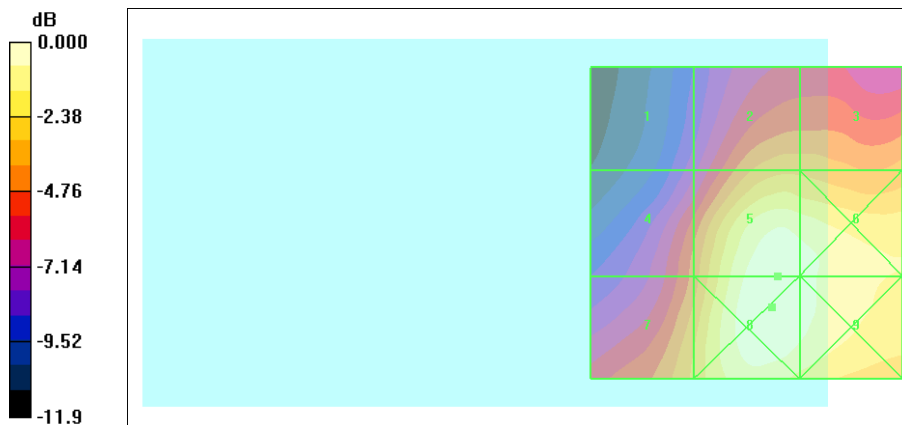

0 dB = 147.8V/m



Test Laboratory: A Test Lab Techno Corp. Date/Time: 12/26/2006 9:54:50 PM

**HAC\_CDMA PCS CH25\_802.11g CH6\_E**

**DUT: TTTA200; Type:Pocket PC Phone; FCC ID:NM8TITA100**

Communication System: CDMA PCS ; Frequency: 1851.25 MHz;Duty Cycle: 1:1

Medium parameters used:  $\sigma = 0$  mho/m,  $\epsilon_r = 1$ ;  $\rho = 1000$  kg/m<sup>3</sup>

Phantom section: E Device Section

Measurement Standard: DASYS4 (High Precision Assessment)

DASY4 Configuration:

- Probe: ER3DV6 - SN2256; ConvF(1, 1, 1); Calibrated: 10/21/2005
- Sensor-Surface: (Fix Surface)
- Electronics: DAE4 Sn541; Calibrated: 10/16/2006
- Phantom: HAC Test Arch; Type: SD HAC P01 BA; Serial:
- Measurement SW: DASYS4, V4.7 Build 44; Postprocessing SW: SEMCAD, V1.8 Build 171

**E Scan - ER3DV6 probe center 10mm above Device Reference/Hearing Aid Compatibility Test (101x101x1):**

Measurement grid: dx=5mm, dy=5mm

Maximum value of peak Total field = 76.4 V/m

Probe Modulation Factor = 1.06

Reference Value = 57.7 V/m; Power Drift = 0.021 dB

**Hearing Aid Near-Field Category: M3 (AWF 0 dB)**

Peak E-field in V/m

Grid 1	Grid 2	Grid 3
<b>50.5</b>	<b>67.2</b>	<b>66.2</b>
Grid 4	Grid 5	Grid 6
<b>60.9</b>	<b>76.4</b>	<b>68.1</b>
Grid 7	Grid 8	Grid 9
<b>95.0</b>	<b>104.4</b>	<b>85.8</b>

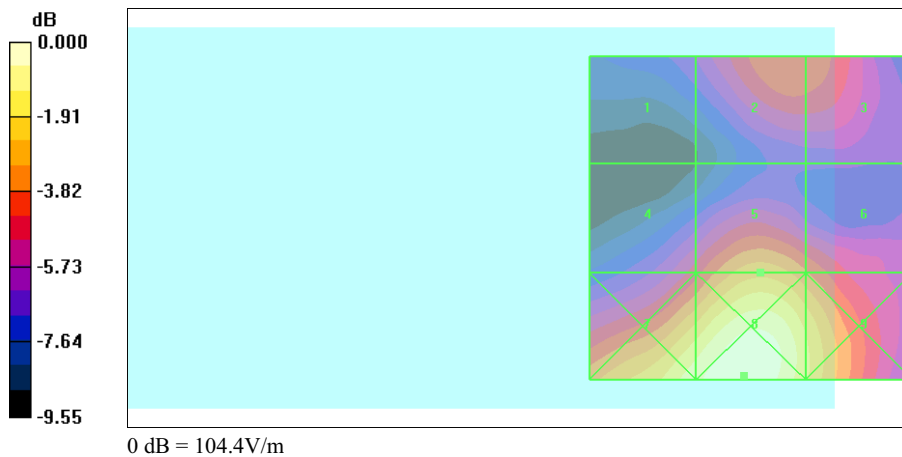



Test Laboratory: A Test Lab Techno Corp. Date/Time: 12/26/2006 9:49:22 PM

**HAC\_CDMA PCS CH600\_802.11g CH6\_E**

**DUT: TTTA200; Type:Pocket PC Phone; FCC ID:NM8TITA100**

Communication System: CDMA PCS ; Frequency: 1880 MHz;Duty Cycle: 1:1

Medium parameters used:  $\sigma = 0$  mho/m,  $\epsilon_r = 1$ ;  $\rho = 1000$  kg/m<sup>3</sup>

Phantom section: E Device Section

Measurement Standard: DASYS4 (High Precision Assessment)

DASY4 Configuration:

- Probe: ER3DV6 - SN2256; ConvF(1, 1, 1); Calibrated: 10/21/2005
- Sensor-Surface: (Fix Surface)
- Electronics: DAE4 Sn541; Calibrated: 10/16/2006
- Phantom: HAC Test Arch; Type: SD HAC P01 BA; Serial:
- Measurement SW: DASYS4, V4.7 Build 44; Postprocessing SW: SEMCAD, V1.8 Build 171

**E Scan - ER3DV6 probe center 10mm above Device Reference/Hearing Aid Compatibility Test (101x101x1):**

Measurement grid: dx=5mm, dy=5mm

Maximum value of peak Total field = 76.9 V/m

Probe Modulation Factor = 1.06

Reference Value = 55.2 V/m; Power Drift = -0.037 dB

**Hearing Aid Near-Field Category: M3 (AWF 0 dB)**

Peak E-field in V/m

Grid 1	Grid 2	Grid 3
<b>58.7</b>	<b>76.9</b>	<b>75.4</b>
Grid 4	Grid 5	Grid 6
<b>60.5</b>	<b>76.7</b>	<b>69.7</b>
Grid 7	Grid 8	Grid 9
<b>100.7</b>	<b>110.0</b>	<b>91.3</b>

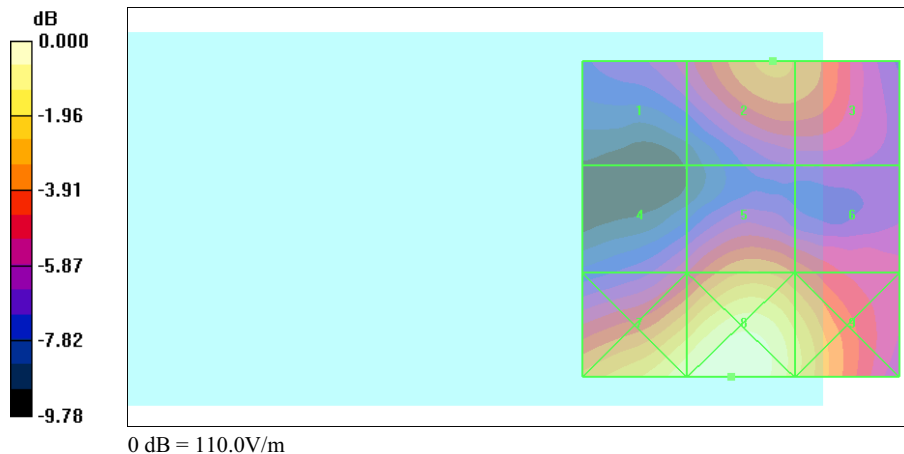



Test Laboratory: A Test Lab Techno Corp. Date/Time: 12/26/2006 9:43:48 PM

**HAC\_CDMA PCS CH1175\_802.11g CH6\_E**

**DUT: TTTA200; Type:Pocket PC Phone; FCC ID:NM8TITA100**

Communication System: CDMA PCS ; Frequency: 1908.75 MHz;Duty Cycle: 1:1

Medium parameters used:  $\sigma = 0$  mho/m,  $\epsilon_r = 1$ ;  $\rho = 1000$  kg/m<sup>3</sup>

Phantom section: E Device Section

Measurement Standard: DASYS4 (High Precision Assessment)

DASY4 Configuration:

- Probe: ER3DV6 - SN2256; ConvF(1, 1, 1); Calibrated: 10/21/2005
- Sensor-Surface: (Fix Surface)
- Electronics: DAE4 Sn541; Calibrated: 10/16/2006
- Phantom: HAC Test Arch; Type: SD HAC P01 BA; Serial:
- Measurement SW: DASYS4, V4.7 Build 44; Postprocessing SW: SEMCAD, V1.8 Build 171

**E Scan - ER3DV6 probe center 10mm above Device Reference/Hearing Aid Compatibility Test (101x101x1):**

Measurement grid: dx=5mm, dy=5mm

Maximum value of peak Total field = 81.5 V/m

Probe Modulation Factor = 1.06

Reference Value = 49.6 V/m; Power Drift = -0.178 dB

**Hearing Aid Near-Field Category: M3 (AWF 0 dB)**

Peak E-field in V/m

Grid 1	Grid 2	Grid 3
<b>62.5</b>	<b>81.5</b>	<b>79.8</b>
Grid 4	Grid 5	Grid 6
<b>55.5</b>	<b>70.0</b>	<b>64.9</b>
Grid 7	Grid 8	Grid 9
<b>98.9</b>	<b>106.8</b>	<b>88.3</b>

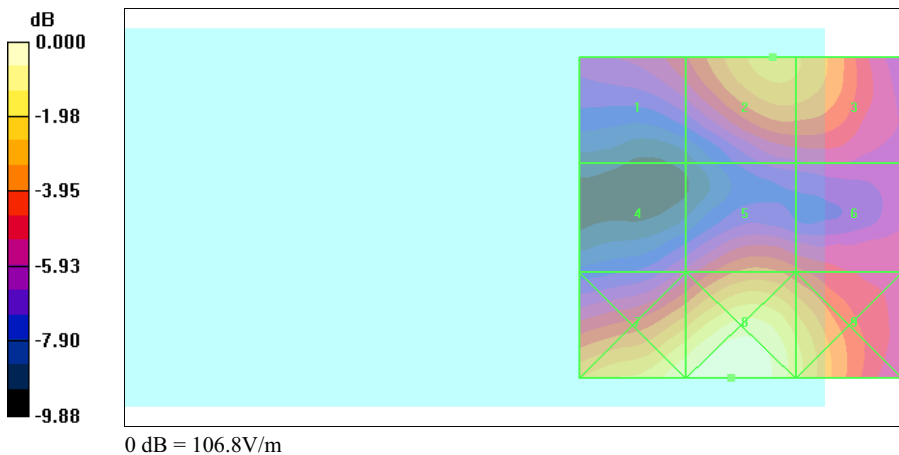





Test Laboratory: A Test Lab Techno Corp. Date/Time: 12/27/2006 3:06:18 AM

**HAC\_CDMA Cellular CH1013\_Bluetooth CH39\_E**

**DUT:TTTA200; Type:Pocket PC Phone; FCC ID:NM8TITA100**

Communication System: CDMA Cellular ; Frequency: 824.7 MHz;Duty Cycle: 1:1

Medium parameters used:  $\sigma = 0$  mho/m,  $\epsilon_r = 1$ ;  $\rho = 1000$  kg/m<sup>3</sup>

Phantom section: E Device Section

Measurement Standard: DASYS4 (High Precision Assessment)

DASY4 Configuration:

- Probe: ER3DV6 - SN2256; ConvF(1, 1, 1); Calibrated: 10/21/2005
- Sensor-Surface: (Fix Surface)
- Electronics: DAE4 Sn541; Calibrated: 10/16/2006
- Phantom: HAC Test Arch; Type: SD HAC P01 BA; Serial:
- Measurement SW: DASYS4, V4.7 Build 44; Postprocessing SW: SEMCAD, V1.8 Build 171

**E Scan - ER3DV6 probe center 10mm above Device Reference/Hearing Aid Compatibility Test (101x101x1):**

Measurement grid: dx=5mm, dy=5mm

Maximum value of peak Total field = 147.5 V/m

Probe Modulation Factor = 1.33

Reference Value = 104.3 V/m; Power Drift = -0.117 dB

**Hearing Aid Near-Field Category: M4 (AWF 0 dB)**

Peak E-field in V/m

Grid 1	Grid 2	Grid 3
<b>63.0</b>	<b>104.3</b>	<b>103.7</b>
Grid 4	Grid 5	Grid 6
<b>89.7</b>	<b>147.5</b>	<b>142.1</b>
Grid 7	Grid 8	Grid 9
<b>103.8</b>	<b>148.3</b>	<b>141.4</b>

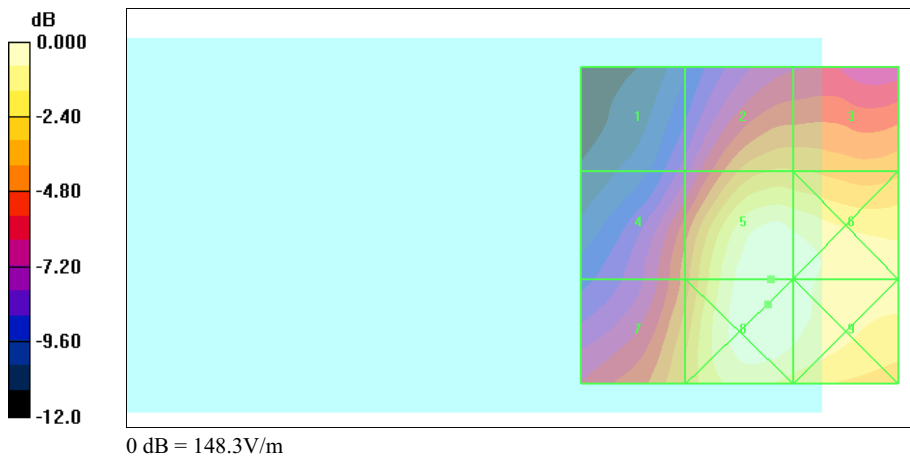



Test Laboratory: A Test Lab Techno Corp. Date/Time: 12/27/2006 3:17:30 AM

**HAC\_CDMA Cellular CH384\_Bluetooth CH39\_E**

**DUT: TTTA200; Type:Pocket PC Phone; FCC ID:NM8TITA100**

Communication System: CDMA Cellular ; Frequency: 836.52 MHz;Duty Cycle: 1:1

Medium parameters used:  $\sigma = 0$  mho/m,  $\epsilon_r = 1$ ;  $\rho = 1000$  kg/m<sup>3</sup>

Phantom section: E Device Section

Measurement Standard: DAS4 (High Precision Assessment)

DASY4 Configuration:

- Probe: ER3DV6 - SN2256; ConvF(1, 1, 1); Calibrated: 10/21/2005
- Sensor-Surface: (Fix Surface)
- Electronics: DAE4 Sn541; Calibrated: 10/16/2006
- Phantom: HAC Test Arch; Type: SD HAC P01 BA; Serial:
- Measurement SW: DAS4, V4.7 Build 44; Postprocessing SW: SEMCAD, V1.8 Build 171

**E Scan - ER3DV6 probe center 10mm above Device Reference/Hearing Aid Compatibility Test (101x101x1):**

Measurement grid: dx=5mm, dy=5mm

Maximum value of peak Total field = 170.3 V/m

Probe Modulation Factor = 1.33

Reference Value = 116.9 V/m; Power Drift = 0.007 dB

**Hearing Aid Near-Field Category: M4 (AWF 0 dB)**

Peak E-field in V/m

Grid 1	Grid 2	Grid 3
<b>71.7</b>	<b>118.7</b>	<b>117.6</b>
Grid 4	Grid 5	Grid 6
<b>104.0</b>	<b>170.3</b>	<b>164.0</b>
Grid 7	Grid 8	Grid 9
<b>120.5</b>	<b>171.3</b>	<b>163.3</b>

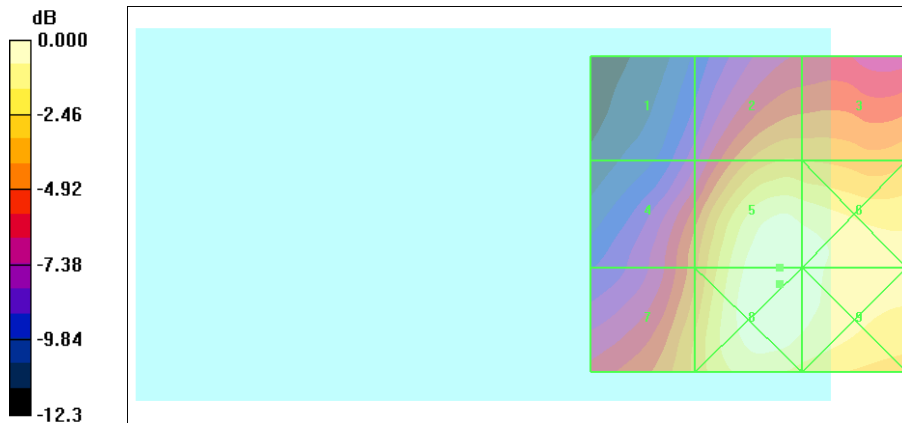

0 dB = 171.3V/m



Test Laboratory: A Test Lab Techno Corp. Date/Time: 12/27/2006 3:22:53 AM

**HAC\_CDMA Cellular CH777\_Bluetooth CH39\_E**

**DUT: TTTA200; Type:Pocket PC Phone; FCC ID:NM8TITA100**

Communication System: CDMA Cellular ; Frequency: 848.31 MHz;Duty Cycle: 1:1

Medium parameters used:  $\sigma = 0$  mho/m,  $\epsilon_r = 1$ ;  $\rho = 1000$  kg/m<sup>3</sup>

Phantom section: E Device Section

Measurement Standard: DASYS4 (High Precision Assessment)

DASY4 Configuration:

- Probe: ER3DV6 - SN2256; ConvF(1, 1, 1); Calibrated: 10/21/2005
- Sensor-Surface: (Fix Surface)
- Electronics: DAE4 Sn541; Calibrated: 10/16/2006
- Phantom: HAC Test Arch; Type: SD HAC P01 BA; Serial:
- Measurement SW: DASYS4, V4.7 Build 44; Postprocessing SW: SEMCAD, V1.8 Build 171

**E Scan - ER3DV6 probe center 10mm above Device Reference/Hearing Aid Compatibility Test (101x101x1):**

Measurement grid: dx=5mm, dy=5mm

Maximum value of peak Total field = 148.3 V/m

Probe Modulation Factor = 1.33

Reference Value = 100.9 V/m; Power Drift = 0.035 dB

**Hearing Aid Near-Field Category: M4 (AWF 0 dB)**

Peak E-field in V/m

Grid 1	Grid 2	Grid 3
<b>62.8</b>	<b>102.7</b>	<b>101.8</b>
Grid 4	Grid 5	Grid 6
<b>91.2</b>	<b>148.3</b>	<b>141.8</b>
Grid 7	Grid 8	Grid 9
<b>107.3</b>	<b>149.5</b>	<b>142.1</b>

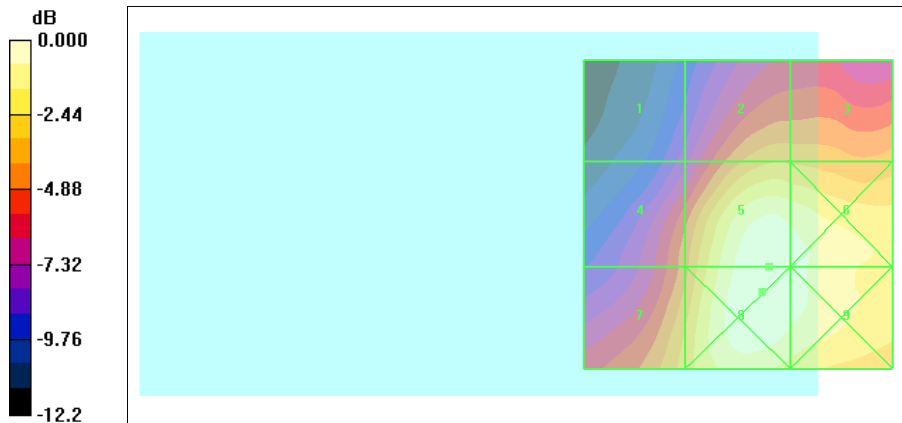

0 dB = 149.5V/m



Test Laboratory: A Test Lab Techno Corp. Date/Time: 12/27/2006 2:48:39 AM

**HAC\_CDMA PCS CH25\_Bluetooth CH39\_E**

**DUT: TTTA200; Type:Pocket PC Phone; FCC ID:NM8TITA100**

Communication System: CDMA PCS ; Frequency: 1851.25 MHz;Duty Cycle: 1:1

Medium parameters used:  $\sigma = 0$  mho/m,  $\epsilon_r = 1$ ;  $\rho = 1000$  kg/m<sup>3</sup>

Phantom section: E Device Section

Measurement Standard: DASYS4 (High Precision Assessment)

DASY4 Configuration:

- Probe: ER3DV6 - SN2256; ConvF(1, 1, 1); Calibrated: 10/21/2005
- Sensor-Surface: (Fix Surface)
- Electronics: DAE4 Sn541; Calibrated: 10/16/2006
- Phantom: HAC Test Arch; Type: SD HAC P01 BA; Serial:
- Measurement SW: DASYS4, V4.7 Build 44; Postprocessing SW: SEMCAD, V1.8 Build 171

**E Scan - ER3DV6 probe center 10mm above Device Reference/Hearing Aid Compatibility Test (101x101x1):**

Measurement grid:dx=5mm, dy=5mm

Maximum value of peak Total field = 77.5 V/m

Probe Modulation Factor = 1.06

Reference Value = 53.0 V/m; Power Drift = 0.18 dB

**Hearing Aid Near-Field Category: M3 (AWF 0 dB)**

Peak E-field in V/m

Grid 1	Grid 2	Grid 3
<b>48.8</b>	<b>68.5</b>	<b>68.3</b>
Grid 4	Grid 5	Grid 6
<b>60.5</b>	<b>77.5</b>	<b>70.4</b>
Grid 7	Grid 8	Grid 9
<b>90.5</b>	<b>100.7</b>	<b>86.9</b>

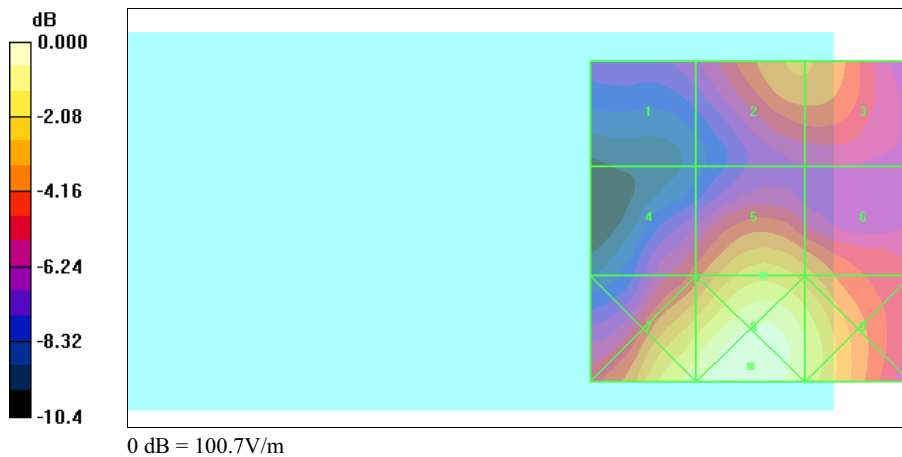



Test Laboratory: A Test Lab Techno Corp. Date/Time: 12/27/2006 2:54:32 AM

**HAC\_CDMA PCS CH600\_Bluetooth CH39\_E**

**DUT: TTTA200; Type:Pocket PC Phone; FCC ID:NM8TITA100**

Communication System: CDMA PCS ; Frequency: 1908.75 MHz;Duty Cycle: 1:1

Medium parameters used:  $\sigma = 0$  mho/m,  $\epsilon_r = 1$ ;  $\rho = 1000$  kg/m<sup>3</sup>

Phantom section: E Device Section

Measurement Standard: DASy4 (High Precision Assessment)

DASy4 Configuration:

- Probe: ER3DV6 - SN2256; ConvF(1, 1, 1); Calibrated: 10/21/2005
- Sensor-Surface: (Fix Surface)
- Electronics: DAE4 Sn541; Calibrated: 10/16/2006
- Phantom: HAC Test Arch; Type: SD HAC P01 BA; Serial:
- Measurement SW: DASy4, V4.7 Build 44; Postprocessing SW: SEMCAD, V1.8 Build 171

**E Scan - ER3DV6 probe center 10mm above Device Reference/Hearing Aid Compatibility Test (101x101x1):**

Measurement grid: dx=5mm, dy=5mm

Maximum value of peak Total field = 77.2 V/m

Probe Modulation Factor = 1.06

Reference Value = 57.6 V/m; Power Drift = -0.034 dB

**Hearing Aid Near-Field Category: M3 (AWF 0 dB)**

Peak E-field in V/m

Grid 1	Grid 2	Grid 3
<b>54.3</b>	<b>75.9</b>	<b>75.4</b>
Grid 4	Grid 5	Grid 6
<b>61.4</b>	<b>77.2</b>	<b>71.1</b>
Grid 7	Grid 8	Grid 9
<b>95.7</b>	<b>105.4</b>	<b>89.9</b>

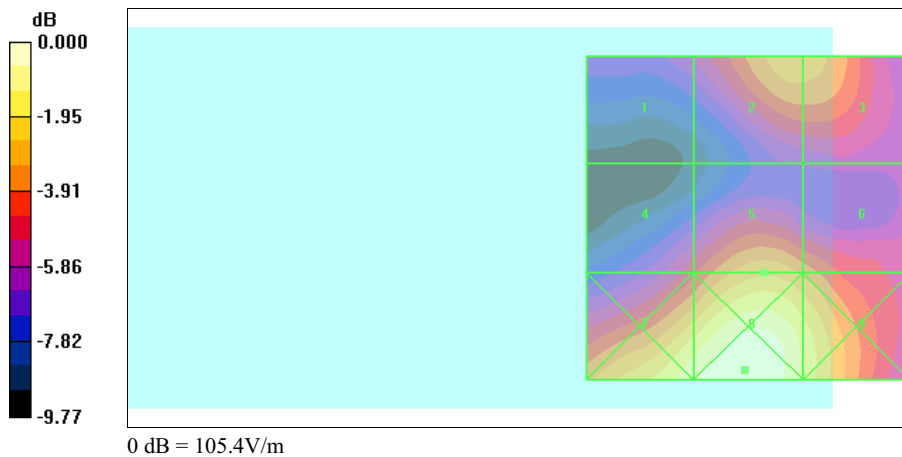



Test Laboratory: A Test Lab Techno Corp. Date/Time: 12/27/2006 3:00:07 AM

**HAC\_CDMA PCS CH1175\_Bluetooth CH39\_E**

**DUT: TTTA200; Type:Pocket PC Phone; FCC ID:NM8TITA100**

Communication System: CDMA PCS ; Frequency: 1908.75 MHz;Duty Cycle: 1:1

Medium parameters used:  $\sigma = 0$  mho/m,  $\epsilon_r = 1$ ;  $\rho = 1000$  kg/m<sup>3</sup>

Phantom section: E Device Section

Measurement Standard: DASYS4 (High Precision Assessment)

DASY4 Configuration:

- Probe: ER3DV6 - SN2256; ConvF(1, 1, 1); Calibrated: 10/21/2005
- Sensor-Surface: (Fix Surface)
- Electronics: DAE4 Sn541; Calibrated: 10/16/2006
- Phantom: HAC Test Arch; Type: SD HAC P01 BA; Serial:
- Measurement SW: DASYS4, V4.7 Build 44; Postprocessing SW: SEMCAD, V1.8 Build 171

**E Scan - ER3DV6 probe center 10mm above Device Reference/Hearing Aid Compatibility Test (101x101x1):**

Measurement grid:dx=5mm, dy=5mm

Maximum value of peak Total field = 79.3 V/m

Probe Modulation Factor = 1.06

Reference Value = 49.7 V/m; Power Drift = 0.012 dB

**Hearing Aid Near-Field Category: M3 (AWF 0 dB)**

Peak E-field in V/m

Grid 1	Grid 2	Grid 3
<b>56.0</b>	<b>79.3</b>	<b>78.9</b>
Grid 4	Grid 5	Grid 6
<b>55.9</b>	<b>70.0</b>	<b>65.0</b>
Grid 7	Grid 8	Grid 9
<b>94.1</b>	<b>102.9</b>	<b>86.6</b>

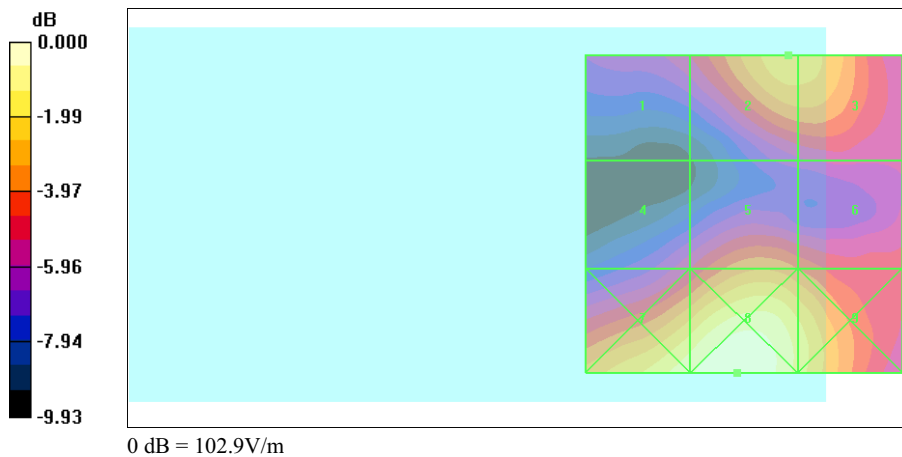



Test Laboratory: A Test Lab Techno Corp.

Date/Time: 10/21/2006 3:39:01 PM

**802.11b CH1\_E**

**DUT: TTTA200; Type:Pocket PC Phone; FCC ID:NM8TITA100**

Communication System: IEEE 802.11b; Frequency: 2412 MHz;Duty Cycle: 1:1

Medium parameters used:  $\sigma = 0$  mho/m,  $\epsilon_r = 1$ ;  $\rho = 1000$  kg/m<sup>3</sup>

Phantom section: E Device Section

Measurement Standard: DASYS4 (High Precision Assessment)

DASY4 Configuration:

- Probe: ER3DV6 - SN2256; ConvF(1, 1, 1); Calibrated: 10/21/2005
- Sensor-Surface: (Fix Surface)
- Electronics: DAE3 Sn393; Calibrated: 9/5/2006
- Phantom: HAC Test Arch; Type: SD HAC P01 BA; Serial:
- Measurement SW: DASYS4, V4.7 Build 44; Postprocessing SW: SEMCAD, V1.8 Build 171

**E Scan - ER3DV6 probe center 10mm above Device Reference/Hearing Aid Compatibility Test (101x101x1):**

Measurement grid: dx=5mm, dy=5mm

Maximum value of peak Total field = 15.4 V/m

Probe Modulation Factor = 0.880

Reference Value = 10.0 V/m; Power Drift = -0.118 dB

**Hearing Aid Near-Field Category: M4 (AWF 0 dB)**

Peak E-field in V/m

Grid 1	Grid 2	Grid 3
<b>14.3</b>	<b>16.3</b>	<b>12.6</b>
Grid 4	Grid 5	Grid 6
<b>11.4</b>	<b>12.3</b>	<b>9.29</b>
Grid 7	Grid 8	Grid 9
<b>12.2</b>	<b>15.4</b>	<b>13.9</b>

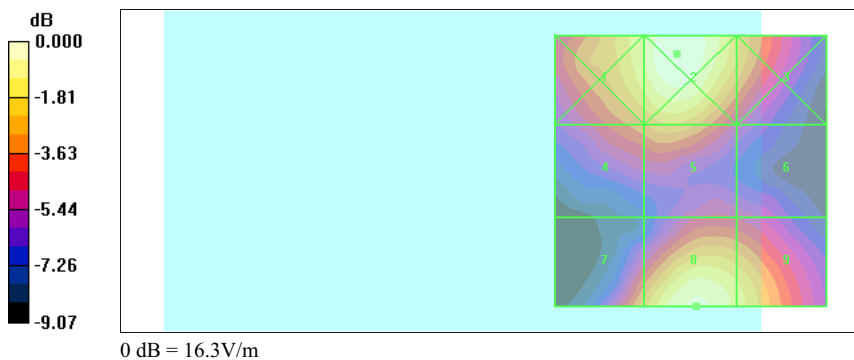



Test Laboratory: A Test Lab Techno Corp.

Date/Time: 10/21/2006 3:51:48 PM

**802.11b CH6\_E**

**DUT: TTTA200; Type:Pocket PC Phone; FCC ID:NM8TITA100**

Communication System: IEEE 802.11b; Frequency: 2437 MHz;Duty Cycle: 1:1

Medium parameters used:  $\sigma = 0$  mho/m,  $\epsilon_r = 1$ ;  $\rho = 1000$  kg/m<sup>3</sup>

Phantom section: E Device Section

Measurement Standard: DASYS4 (High Precision Assessment)

DASY4 Configuration:

- Probe: ER3DV6 - SN2256; ConvF(1, 1, 1); Calibrated: 10/21/2005
- Sensor-Surface: (Fix Surface)
- Electronics: DAE3 Sn393; Calibrated: 9/5/2006
- Phantom: HAC Test Arch; Type: SD HAC P01 BA; Serial:
- Measurement SW: DASYS4, V4.7 Build 44; Postprocessing SW: SEMCAD, V1.8 Build 171

**E Scan - ER3DV6 probe center 10mm above Device Reference/Hearing Aid Compatibility Test (101x101x1):**

Measurement grid: dx=5mm, dy=5mm

Maximum value of peak Total field = 14.4 V/m

Probe Modulation Factor = 0.880

Reference Value = 8.79 V/m; Power Drift = 0.186 dB

**Hearing Aid Near-Field Category: M4 (AWF 0 dB)**

Peak E-field in V/m

Grid 1	Grid 2	Grid 3
<b>13.7</b>	<b>15.3</b>	<b>11.9</b>
Grid 4	Grid 5	Grid 6
<b>10.9</b>	<b>11.4</b>	<b>9.06</b>
Grid 7	Grid 8	Grid 9
<b>11.0</b>	<b>14.4</b>	<b>13.5</b>

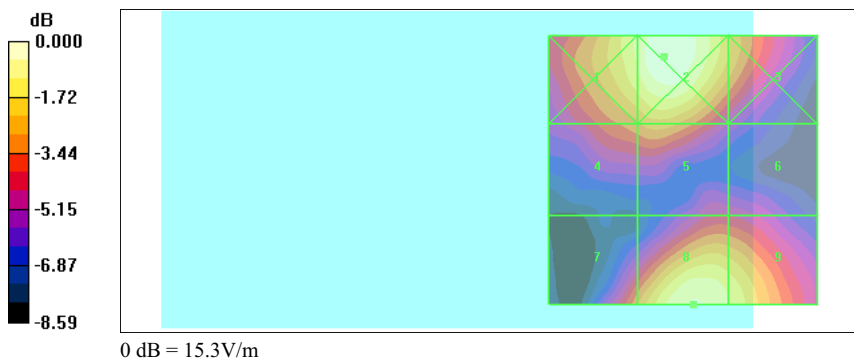





Test Laboratory: A Test Lab Techno Corp.

Date/Time: 10/21/2006 3:58:23 PM

**802.11b CH11\_E**

**DUT: TTTA200; Type:Pocket PC Phone; FCC ID:NM8TITA100**

Communication System: IEEE 802.11b; Frequency: 2462 MHz;Duty Cycle: 1:1

Medium parameters used:  $\sigma = 0$  mho/m,  $\epsilon_r = 1$ ;  $\rho = 1000$  kg/m<sup>3</sup>

Phantom section: E Device Section

Measurement Standard: DASYS4 (High Precision Assessment)

DASY4 Configuration:

- Probe: ER3DV6 - SN2256; ConvF(1, 1, 1); Calibrated: 10/21/2005
- Sensor-Surface: (Fix Surface)
- Electronics: DAE3 Sn393; Calibrated: 9/5/2006
- Phantom: HAC Test Arch; Type: SD HAC P01 BA; Serial:
- Measurement SW: DASYS4, V4.7 Build 44; Postprocessing SW: SEMCAD, V1.8 Build 171

**E Scan - ER3DV6 probe center 10mm above Device Reference/Hearing Aid Compatibility Test (101x101x1):**

Measurement grid: dx=5mm, dy=5mm

Maximum value of peak Total field = 14.9 V/m

Probe Modulation Factor = 0.880

Reference Value = 9.29 V/m; Power Drift = -0.157 dB

**Hearing Aid Near-Field Category: M4 (AWF 0 dB)**

Peak E-field in V/m

Grid 1	Grid 2	Grid 3
<b>13.8</b>	<b>15.7</b>	<b>12.5</b>
Grid 4	Grid 5	Grid 6
<b>10.6</b>	<b>11.5</b>	<b>9.58</b>
Grid 7	Grid 8	Grid 9
<b>10.7</b>	<b>14.9</b>	<b>14.1</b>

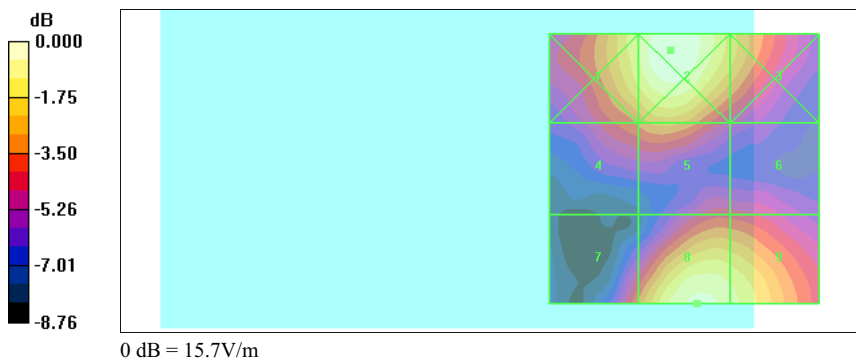



Test Laboratory: A Test Lab Techno Corp.

Date/Time: 10/21/2006 3:26:38 PM

**802.11g CH1\_E**

**DUT: TTTA200; Type:Pocket PC Phone; FCC ID:NM8TITA100**

Communication System: IEEE 802.11g; Frequency: 2412 MHz;Duty Cycle: 1:1

Medium parameters used:  $\sigma = 0$  mho/m,  $\epsilon_r = 1$ ;  $\rho = 1000$  kg/m<sup>3</sup>

Phantom section: E Device Section

Measurement Standard: DASYS4 (High Precision Assessment)

DASY4 Configuration:

- Probe: ER3DV6 - SN2256; ConvF(1, 1, 1); Calibrated: 10/21/2005
- Sensor-Surface: (Fix Surface)
- Electronics: DAE3 Sn393; Calibrated: 9/5/2006
- Phantom: HAC Test Arch; Type: SD HAC P01 BA; Serial:
- Measurement SW: DASYS4, V4.7 Build 44; Postprocessing SW: SEMCAD, V1.8 Build 171

**E Scan - ER3DV6 probe center 10mm above Device Reference/Hearing Aid Compatibility Test (101x101x1):**

Measurement grid: dx=5mm, dy=5mm

Maximum value of peak Total field = 10.1 V/m

Probe Modulation Factor = 0.650

Reference Value = 11.5 V/m; Power Drift = -0.142 dB

**Hearing Aid Near-Field Category: M4 (AWF 0 dB)**

Peak E-field in V/m

Grid 1	Grid 2	Grid 3
<b>11.0</b>	<b>12.2</b>	<b>9.18</b>
Grid 4	Grid 5	Grid 6
<b>8.89</b>	<b>9.45</b>	<b>7.04</b>
Grid 7	Grid 8	Grid 9
<b>7.82</b>	<b>10.1</b>	<b>9.30</b>

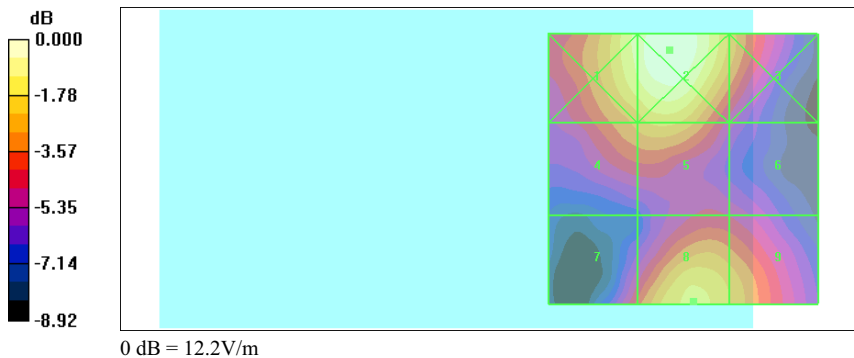



Test Laboratory: A Test Lab Techno Corp.

Date/Time: 10/21/2006 3:17:47 PM

**802.11g CH6\_E**

**DUT: TTTA200; Type:Pocket PC Phone; FCC ID:NM8TITA100**

Communication System: IEEE 802.11g; Frequency: 2437 MHz;Duty Cycle: 1:1

Medium parameters used:  $\sigma = 0$  mho/m,  $\epsilon_r = 1$ ;  $\rho = 1000$  kg/m<sup>3</sup>

Phantom section: E Device Section

Measurement Standard: DASYS4 (High Precision Assessment)

DASY4 Configuration:

- Probe: ER3DV6 - SN2256; ConvF(1, 1, 1); Calibrated: 10/21/2005
- Sensor-Surface: (Fix Surface)
- Electronics: DAE3 Sn393; Calibrated: 9/5/2006
- Phantom: HAC Test Arch; Type: SD HAC P01 BA; Serial:
- Measurement SW: DASYS4, V4.7 Build 44; Postprocessing SW: SEMCAD, V1.8 Build 171

**E Scan - ER3DV6 probe center 10mm above Device Reference/Hearing Aid Compatibility Test (101x101x1):**

Measurement grid: dx=5mm, dy=5mm

Maximum value of peak Total field = 9.93 V/m

Probe Modulation Factor = 0.650

Reference Value = 10.5 V/m; Power Drift = 0.023 dB

**Hearing Aid Near-Field Category: M4 (AWF 0 dB)**

Peak E-field in V/m

Grid 1	Grid 2	Grid 3
<b>10.6</b>	<b>11.8</b>	<b>8.82</b>
Grid 4	Grid 5	Grid 6
<b>8.55</b>	<b>9.06</b>	<b>6.86</b>
Grid 7	Grid 8	Grid 9
<b>7.24</b>	<b>9.93</b>	<b>9.25</b>

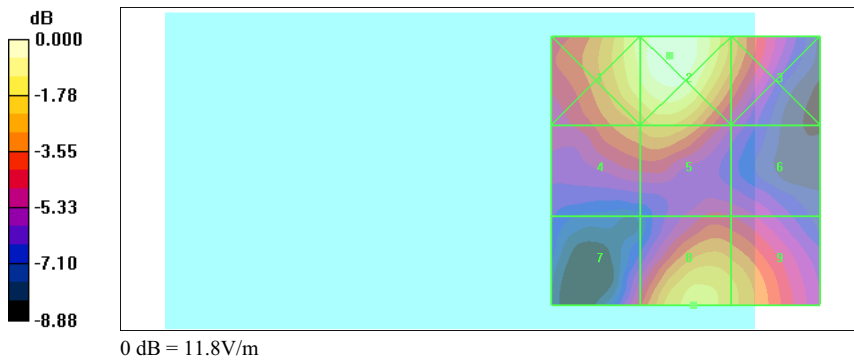



Test Laboratory: A Test Lab Techno Corp.

Date/Time: 10/21/2006 3:11:07 PM

**802.11g CH11\_E**

**DUT: TTTA200; Type:Pocket PC Phone; FCC ID:NM8TITA100**

Communication System: IEEE 802.11g; Frequency: 2462 MHz;Duty Cycle: 1:1

Medium parameters used:  $\sigma = 0$  mho/m,  $\epsilon_r = 1$ ;  $\rho = 1000$  kg/m<sup>3</sup>

Phantom section: E Device Section

Measurement Standard: DASYS4 (High Precision Assessment)

DASY4 Configuration:

- Probe: ER3DV6 - SN2256; ConvF(1, 1, 1); Calibrated: 10/21/2005
- Sensor-Surface: (Fix Surface)
- Electronics: DAE3 Sn393; Calibrated: 9/5/2006
- Phantom: HAC Test Arch; Type: SD HAC P01 BA; Serial:
- Measurement SW: DASYS4, V4.7 Build 44; Postprocessing SW: SEMCAD, V1.8 Build 171

**E Scan - ER3DV6 probe center 10mm above Device Reference/Hearing Aid Compatibility Test (101x101x1):**

Measurement grid: dx=5mm, dy=5mm

Maximum value of peak Total field = 9.85 V/m

Probe Modulation Factor = 0.650

Reference Value = 10.5 V/m; Power Drift = 0.097 dB

**Hearing Aid Near-Field Category: M4 (AWF 0 dB)**

Peak E-field in V/m

Grid 1	Grid 2	Grid 3
<b>10.7</b>	<b>11.9</b>	<b>8.94</b>
Grid 4	Grid 5	Grid 6
<b>8.86</b>	<b>9.37</b>	<b>7.00</b>
Grid 7	Grid 8	Grid 9
<b>7.07</b>	<b>9.85</b>	<b>9.49</b>

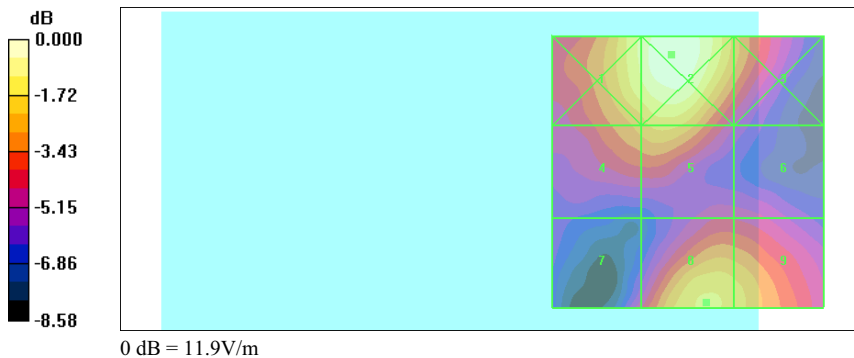



Test Laboratory: A Test Lab Techno Corp.

Date/Time: 10/21/2006 1:05:27 PM

**CDMA 850 CH1013\_H**

**DUT: TTTA200; Type:Pocket PC Phone; FCC ID:NM8TITA100**

Communication System: CDMA; Frequency: 824.7 MHz;Duty Cycle: 1:1

Medium parameters used:  $\sigma = 0$  mho/m,  $\epsilon_r = 1$ ;  $\rho = 1$  kg/m<sup>3</sup>

Phantom section: H Device Section

Measurement Standard: DASYS4 (High Precision Assessment)

DASY4 Configuration:

- Probe: H3DV6 - SN6076; ; Calibrated: 10/21/2005
- Sensor-Surface: (Fix Surface)
- Electronics: DAE3 Sn393; Calibrated: 9/5/2006
- Phantom: HAC Test Arch; Type: SD HAC P01 BA; Serial:
- Measurement SW: DASYS4, V4.7 Build 44; Postprocessing SW: SEMCAD, V1.8 Build 171

**H Scan - H3DV6 probe center 10mm above Device Reference/Hearing Aid Compatibility Test (101x101x1):**

Measurement grid: dx=5mm, dy=5mm

Maximum value of peak Total field = 0.317 A/m

Probe Modulation Factor = 1.25

Reference Value = 0.184 A/m; Power Drift = 0.021 dB

**Hearing Aid Near-Field Category: M4 (AWF 0 dB)**

Peak H-field in A/m

Grid 1	Grid 2	Grid 3
<b>0.314</b>	<b>0.344</b>	<b>0.331</b>
Grid 4	Grid 5	Grid 6
<b>0.304</b>	<b>0.317</b>	<b>0.301</b>
Grid 7	Grid 8	Grid 9
<b>0.241</b>	<b>0.245</b>	<b>0.219</b>

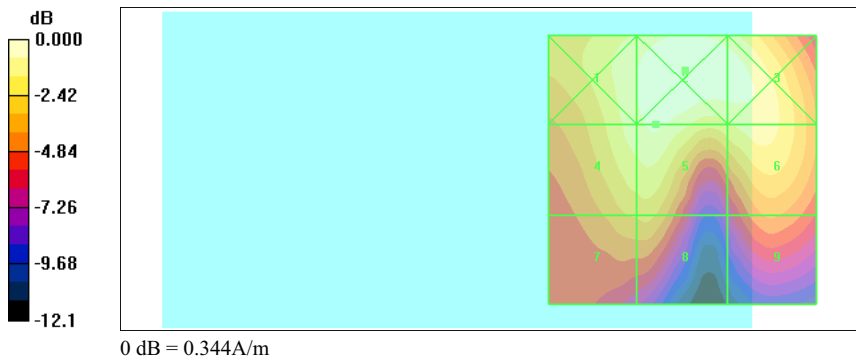



Test Laboratory: A Test Lab Techno Corp.

Date/Time: 10/21/2006 12:52:57 PM

**CDMA 850 CH384\_H**

**DUT: TTTA200; Type:Pocket PC Phone; FCC ID:NM8TITA100**

Communication System: CDMA; Frequency: 836.52 MHz;Duty Cycle: 1:1

Medium parameters used:  $\sigma = 0$  mho/m,  $\epsilon_r = 1$ ;  $\rho = 1$  kg/m<sup>3</sup>

Phantom section: H Device Section

Measurement Standard: DASYS4 (High Precision Assessment)

DASY4 Configuration:

- Probe: H3DV6 - SN6076; ; Calibrated: 10/21/2005
- Sensor-Surface: (Fix Surface)
- Electronics: DAE3 Sn393; Calibrated: 9/5/2006
- Phantom: HAC Test Arch; Type: SD HAC P01 BA; Serial:
- Measurement SW: DASYS4, V4.7 Build 44; Postprocessing SW: SEMCAD, V1.8 Build 171

**H Scan - H3DV6 probe center 10mm above Device Reference/Hearing Aid Compatibility Test (101x101x1):**

Measurement grid: dx=5mm, dy=5mm

Maximum value of peak Total field = 0.365 A/m

Probe Modulation Factor = 1.25

Reference Value = 0.211 A/m; Power Drift = -0.006 dB

**Hearing Aid Near-Field Category: M4 (AWF 0 dB)**

Peak H-field in A/m

Grid 1	Grid 2	Grid 3
<b>0.359</b>	<b>0.392</b>	<b>0.377</b>
Grid 4	Grid 5	Grid 6
<b>0.350</b>	<b>0.365</b>	<b>0.341</b>
Grid 7	Grid 8	Grid 9
<b>0.278</b>	<b>0.283</b>	<b>0.251</b>

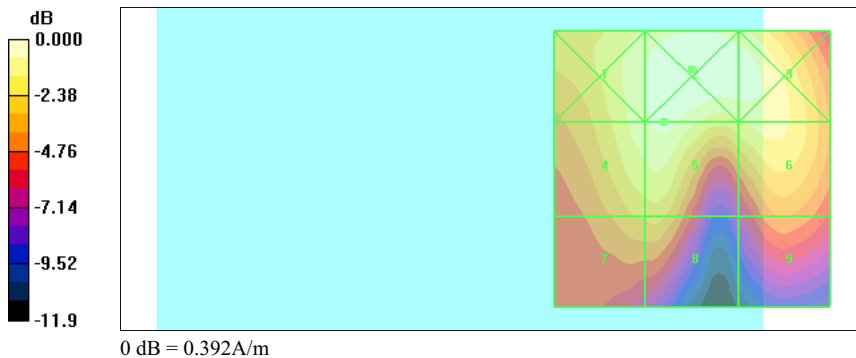



Test Laboratory: A Test Lab Techno Corp.

Date/Time: 10/21/2006 12:58:46 PM

**CDMA 850 CH777\_H**

**DUT: TTTA200; Type:Pocket PC Phone; FCC ID:NM8TITA100**

Communication System: CDMA; Frequency: 848.31 MHz;Duty Cycle: 1:1

Medium parameters used:  $\sigma = 0$  mho/m,  $\epsilon_r = 1$ ;  $\rho = 1$  kg/m<sup>3</sup>

Phantom section: H Device Section

Measurement Standard: DAS4 (High Precision Assessment)

DASY4 Configuration:

- Probe: H3DV6 - SN6076; ; Calibrated: 10/21/2005
- Sensor-Surface: (Fix Surface)
- Electronics: DAE3 Sn393; Calibrated: 9/5/2006
- Phantom: HAC Test Arch; Type: SD HAC P01 BA; Serial:
- Measurement SW: DAS4, V4.7 Build 44; Postprocessing SW: SEMCAD, V1.8 Build 171

**H Scan - H3DV6 probe center 10mm above Device Reference/Hearing Aid Compatibility Test (101x101x1):**

Measurement grid: dx=5mm, dy=5mm

Maximum value of peak Total field = 0.295 A/m

Probe Modulation Factor = 1.25

Reference Value = 0.171 A/m; Power Drift = -0.005 dB

**Hearing Aid Near-Field Category: M4 (AWF 0 dB)**

Peak H-field in A/m

Grid 1	Grid 2	Grid 3
<b>0.287</b>	<b>0.313</b>	<b>0.301</b>
Grid 4	Grid 5	Grid 6
<b>0.283</b>	<b>0.295</b>	<b>0.275</b>
Grid 7	Grid 8	Grid 9
<b>0.225</b>	<b>0.229</b>	<b>0.204</b>

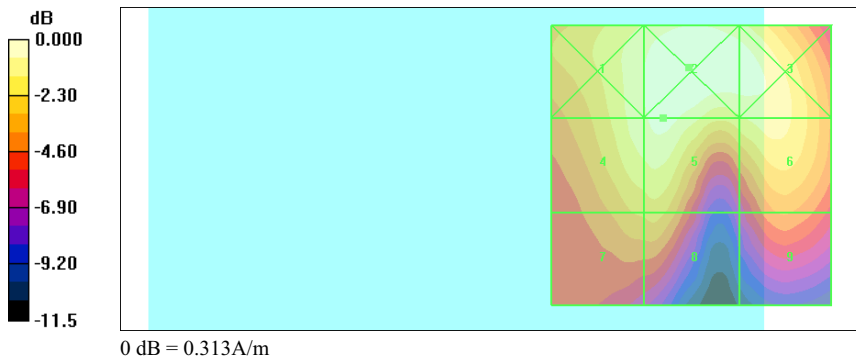



Test Laboratory: A Test Lab Techno Corp.

Date/Time: 10/21/2006 12:31:42 PM

**CDMA 1900 CH25\_H**

**DUT: TTTA200; Type:Pocket PC Phone; FCC ID:NM8TITA100**

Communication System: PCS 1900; Frequency: 1851.25 MHz;Duty Cycle: 1:1

Medium parameters used:  $\sigma = 0$  mho/m,  $\epsilon_r = 1$ ;  $\rho = 1$  kg/m<sup>3</sup>

Phantom section: H Device Section

Measurement Standard: DASYS4 (High Precision Assessment)

DASY4 Configuration:

- Probe: H3DV6 - SN6076; ; Calibrated: 10/21/2005
- Sensor-Surface: (Fix Surface)
- Electronics: DAE3 Sn393; Calibrated: 9/5/2006
- Phantom: HAC Test Arch; Type: SD HAC P01 BA; Serial:
- Measurement SW: DASYS4, V4.7 Build 44; Postprocessing SW: SEMCAD, V1.8 Build 171

**H Scan - H3DV6 probe center 10mm above Device Reference/Hearing Aid Compatibility Test (101x101x1):**

Measurement grid: dx=5mm, dy=5mm

Maximum value of peak Total field = 0.223 A/m

Probe Modulation Factor = 1.08

Reference Value = 0.182 A/m; Power Drift = -0.072 dB

**Hearing Aid Near-Field Category: M3 (AWF 0 dB)**

Peak H-field in A/m

Grid 1	Grid 2	Grid 3
<b>0.208</b>	<b>0.222</b>	<b>0.190</b>
Grid 4	Grid 5	Grid 6
<b>0.210</b>	<b>0.223</b>	<b>0.166</b>
Grid 7	Grid 8	Grid 9
<b>0.189</b>	<b>0.196</b>	<b>0.116</b>

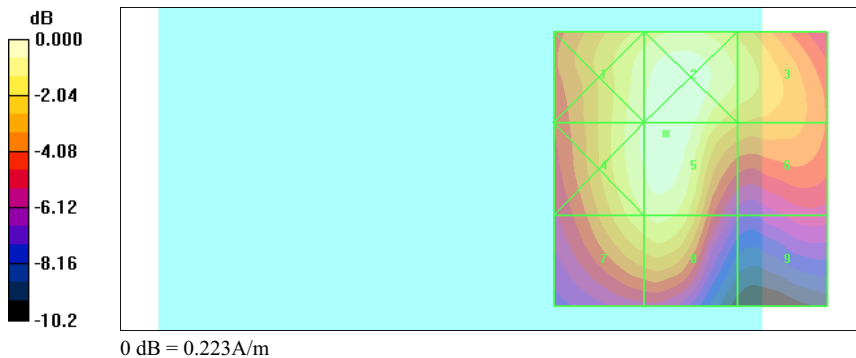





Test Laboratory: A Test Lab Techno Corp.

Date/Time: 10/21/2006 12:38:32 PM

**CDMA 1900 CH600\_H**

**DUT: TTTA200; Type:Pocket PC Phone; FCC ID:NM8TITA100**

Communication System: PCS 1900; Frequency: 1880 MHz;Duty Cycle: 1:1

Medium parameters used:  $\sigma = 0$  mho/m,  $\epsilon_r = 1$ ;  $\rho = 1$  kg/m<sup>3</sup>

Phantom section: H Device Section

Measurement Standard: DASYS4 (High Precision Assessment)

DASY4 Configuration:

- Probe: H3DV6 - SN6076; ; Calibrated: 10/21/2005
- Sensor-Surface: (Fix Surface)
- Electronics: DAE3 Sn393; Calibrated: 9/5/2006
- Phantom: HAC Test Arch; Type: SD HAC P01 BA; Serial:
- Measurement SW: DASYS4, V4.7 Build 44; Postprocessing SW: SEMCAD, V1.8 Build 171

**H Scan - H3DV6 probe center 10mm above Device Reference/Hearing Aid Compatibility Test (101x101x1):**

Measurement grid: dx=5mm, dy=5mm

Maximum value of peak Total field = 0.235 A/m

Probe Modulation Factor = 1.08

Reference Value = 0.194 A/m; Power Drift = 0.056 dB

**Hearing Aid Near-Field Category: M3 (AWF 0 dB)**

Peak H-field in A/m

Grid 1	Grid 2	Grid 3
<b>0.222</b>	<b>0.235</b>	<b>0.201</b>
Grid 4	Grid 5	Grid 6
<b>0.224</b>	<b>0.235</b>	<b>0.179</b>
Grid 7	Grid 8	Grid 9
<b>0.202</b>	<b>0.211</b>	<b>0.125</b>

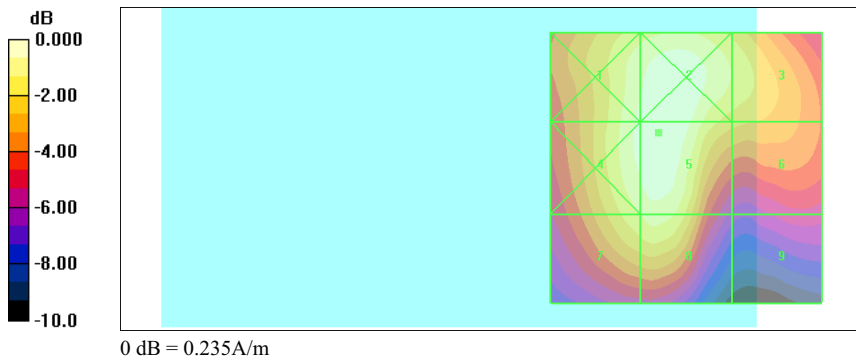



Test Laboratory: A Test Lab Techno Corp.

Date/Time: 10/21/2006 12:46:42 PM

**CDMA 1900 CH1175\_H**

**DUT: TTTA200; Type:Pocket PC Phone; FCC ID:NM8TITA100**

Communication System: PCS 1900; Frequency: 1908.75 MHz;Duty Cycle: 1:1

Medium parameters used:  $\sigma = 0$  mho/m,  $\epsilon_r = 1$ ;  $\rho = 1$  kg/m<sup>3</sup>

Phantom section: H Device Section

Measurement Standard: DASYS4 (High Precision Assessment)

DASY4 Configuration:

- Probe: H3DV6 - SN6076; ; Calibrated: 10/21/2005
- Sensor-Surface: (Fix Surface)
- Electronics: DAE3 Sn393; Calibrated: 9/5/2006
- Phantom: HAC Test Arch; Type: SD HAC P01 BA; Serial:
- Measurement SW: DASYS4, V4.7 Build 44; Postprocessing SW: SEMCAD, V1.8 Build 171

**H Scan - H3DV6 probe center 10mm above Device Reference/Hearing Aid Compatibility Test (101x101x1):**

Measurement grid: dx=5mm,dy=5mm

Maximum value of peak Total field = 0.237 A/m

Probe Modulation Factor = 1.08

Reference Value = 0.198 A/m; Power Drift = -0.081 dB

**Hearing Aid Near-Field Category: M3 (AWF 0 dB)**

Peak H-field in A/m

Grid 1	Grid 2	Grid 3
<b>0.222</b>	<b>0.236</b>	<b>0.202</b>
Grid 4	Grid 5	Grid 6
<b>0.225</b>	<b>0.237</b>	<b>0.183</b>
Grid 7	Grid 8	Grid 9
<b>0.207</b>	<b>0.215</b>	<b>0.129</b>

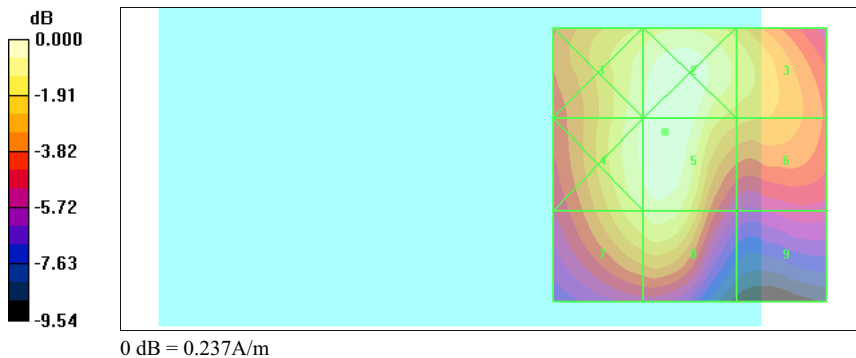



Test Laboratory: A Test Lab Techno Corp. Date/Time: 12/26/2006 7:37:58 PM

**HAC\_CDMA Cellular CH1013\_802.11b CH1\_H**

**DUT: TTTA200; Type:Pocket PC Phone; FCC ID:NM8TITA100**

Communication System: CDMA; Frequency: 824.7 MHz; Duty Cycle: 1:1

Medium parameters used:  $\sigma = 0$  mho/m,  $\epsilon_r = 1$ ;  $\rho = 1$  kg/m<sup>3</sup>

Phantom section: H Device Section

Measurement Standard: DASYS4 (High Precision Assessment)

DASY4 Configuration:

- Probe: H3DV6 - SN6076; ; Calibrated: 10/21/2005
- Sensor-Surface: (Fix Surface)
- Electronics: DAE4 Sn541; Calibrated: 10/16/2006
- Phantom: HAC Test Arch; Type: SD HAC P01 BA; Serial:
- Measurement SW: DASYS4, V4.7 Build 44; Postprocessing SW: SEMCAD, V1.8 Build 171

**H Scan - H3DV6 probe center 10mm above Device Reference/Hearing Aid Compatibility Test (101x101x1):**

Measurement grid: dx=5mm, dy=5mm

Maximum value of peak Total field = 0.374 A/m

Probe Modulation Factor = 1.25

Reference Value = 0.238 A/m; Power Drift = -0.127 dB

**Hearing Aid Near-Field Category: M4 (AWF 0 dB)**

Peak H-field in A/m

Grid 1	Grid 2	Grid 3
<b>0.375</b>	<b>0.400</b>	<b>0.374</b>
Grid 4	Grid 5	Grid 6
<b>0.361</b>	<b>0.374</b>	<b>0.333</b>
Grid 7	Grid 8	Grid 9
<b>0.284</b>	<b>0.288</b>	<b>0.242</b>



0 dB = 0.400A/m



Test Laboratory: A Test Lab Techno Corp. Date/Time: 12/26/2006 7:44:10 PM

**HAC\_CDMA Cellular CH384\_802.11b CH1\_H**

**DUT: TTTA200; Type:Pocket PC Phone; FCC ID:NM8TITA100**

Communication System: CDMA; Frequency: 836.52 MHz;Duty Cycle: 1:1

Medium parameters used:  $\sigma = 0$  mho/m,  $\epsilon_r = 1$ ;  $\rho = 1$  kg/m<sup>3</sup>

Phantom section: H Device Section

Measurement Standard: DASYS4 (High Precision Assessment)

DASY4 Configuration:

- Probe: H3DV6 - SN6076; ; Calibrated: 10/21/2005
- Sensor-Surface: (Fix Surface)
- Electronics: DAE4 Sn541; Calibrated: 10/16/2006
- Phantom: HAC Test Arch; Type: SD HAC P01 BA; Serial:
- Measurement SW: DASYS4, V4.7 Build 44; Postprocessing SW: SEMCAD, V1.8 Build 171

**H Scan - H3DV6 probe center 10mm above Device Reference/Hearing Aid Compatibility Test (101x101x1):**

Measurement grid: dx=5mm, dy=5mm

Maximum value of peak Total field = 0.409 A/m

Probe Modulation Factor = 1.25

Reference Value = 0.258 A/m; Power Drift = -0.053 dB

**Hearing Aid Near-Field Category: M4 (AWF 0 dB)**

Peak H-field in A/m

Grid 1	Grid 2	Grid 3
<b>0.410</b>	<b>0.446</b>	<b>0.426</b>
Grid 4	Grid 5	Grid 6
<b>0.394</b>	<b>0.409</b>	<b>0.378</b>
Grid 7	Grid 8	Grid 9
<b>0.314</b>	<b>0.319</b>	<b>0.274</b>



0 dB = 0.446A/m



Test Laboratory: A Test Lab Techno Corp. Date/Time: 12/26/2006 7:49:33 PM

**HAC\_CDMA Cellular CH777\_802.11b CH1\_H**

**DUT: TTTA200; Type:Pocket PC Phone; FCC ID:NM8TITA100**

Communication System: CDMA; Frequency: 848.31 MHz;Duty Cycle: 1:1

Medium parameters used:  $\sigma = 0$  mho/m,  $\epsilon_r = 1$ ;  $\rho = 1$  kg/m<sup>3</sup>

Phantom section: H Device Section

Measurement Standard: DASYS4 (High Precision Assessment)

DASY4 Configuration:

- Probe: H3DV6 - SN6076; ; Calibrated: 10/21/2005
- Sensor-Surface: (Fix Surface)
- Electronics: DAE4 Sn541; Calibrated: 10/16/2006
- Phantom: HAC Test Arch; Type: SD HAC P01 BA; Serial:
- Measurement SW: DASYS4, V4.7 Build 44; Postprocessing SW: SEMCAD, V1.8 Build 171

**H Scan - H3DV6 probe center 10mm above Device Reference/Hearing Aid Compatibility Test (101x101x1):**

Measurement grid: dx=5mm, dy=5mm

Maximum value of peak Total field = 0.368 A/m

Probe Modulation Factor = 1.25

Reference Value = 0.231 A/m; Power Drift = 0.081 dB

**Hearing Aid Near-Field Category: M4 (AWF 0 dB)**

Peak H-field in A/m

Grid 1	Grid 2	Grid 3
<b>0.365</b>	<b>0.397</b>	<b>0.373</b>
Grid 4	Grid 5	Grid 6
<b>0.353</b>	<b>0.368</b>	<b>0.333</b>
Grid 7	Grid 8	Grid 9
<b>0.283</b>	<b>0.290</b>	<b>0.244</b>

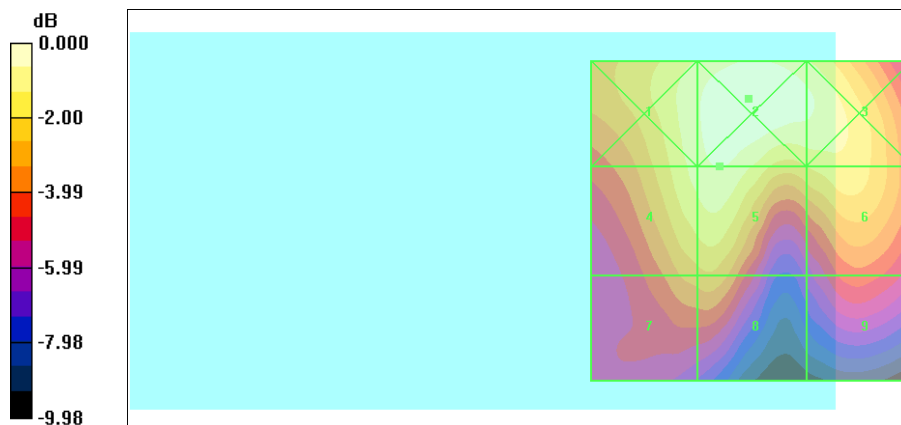

0 dB = 0.397A/m



Test Laboratory: A Test Lab Techno Corp. Date/Time: 12/27/2006 12:10:04 AM

**HAC\_CDMA PCS CH25\_802.11b CH1\_H**

**DUT: TTTA200; Type:Pocket PC Phone; FCC ID:NM8TITA100**

Communication System: CDMA PCS ; Frequency: 1851.25 MHz;Duty Cycle: 1:1

Medium parameters used:  $\sigma = 0$  mho/m,  $\epsilon_r = 1$ ;  $\rho = 1$  kg/m<sup>3</sup>

Phantom section: H Device Section

Measurement Standard: DASYS4 (High Precision Assessment)

DASY4 Configuration:

- Probe: H3DV6 - SN6076; ; Calibrated: 10/21/2005
- Sensor-Surface: (Fix Surface)
- Electronics: DAE4 Sn541; Calibrated: 10/16/2006
- Phantom: HAC Test Arch; Type: SD HAC P01 BA; Serial:
- Measurement SW: DASYS4, V4.7 Build 44; Postprocessing SW: SEMCAD, V1.8 Build 171

**H Scan - H3DV6 probe center 10mm above Device Reference/Hearing Aid Compatibility Test (101x101x1):**

Measurement grid: dx=5mm,dy=5mm

Maximum value of peak Total field = 0.212 A/m

Probe Modulation Factor = 1.08

Reference Value = 0.180 A/m; Power Drift = -0.068 dB

**Hearing Aid Near-Field Category: M3 (AWF 0 dB)**

Peak H-field in A/m

Grid 1	Grid 2	Grid 3
<b>0.197</b>	<b>0.218</b>	<b>0.199</b>
Grid 4	Grid 5	Grid 6
<b>0.197</b>	<b>0.212</b>	<b>0.169</b>
Grid 7	Grid 8	Grid 9
<b>0.179</b>	<b>0.185</b>	<b>0.117</b>

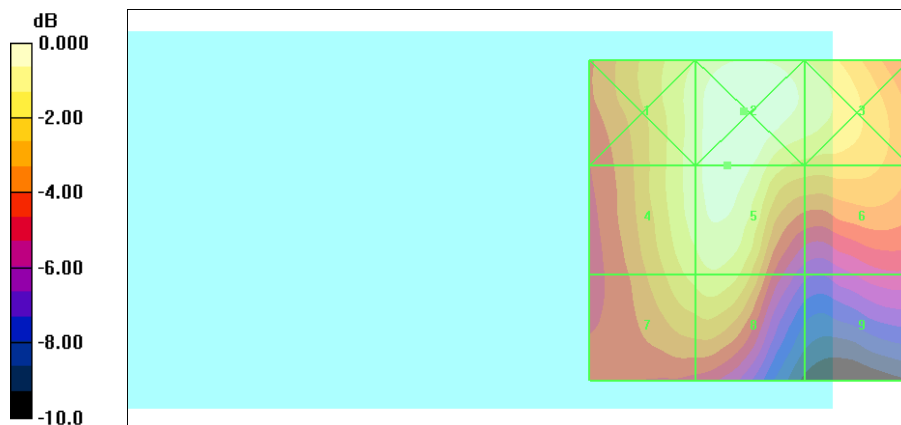

0 dB = 0.218A/m



Test Laboratory: A Test Lab Techno Corp. Date/Time: 12/27/2006 1:08:25 AM

**HAC\_CDMA PCS CH600\_802.11b CH1\_H**

**DUT: TTTA200; Type:Pocket PC Phone; FCC ID:NM8TITA100**

Communication System: CDMA PCS ; Frequency: 1880 MHz;Duty Cycle: 1:1

Medium parameters used:  $\sigma = 0$  mho/m,  $\epsilon_r = 1$ ;  $\rho = 1$  kg/m<sup>3</sup>

Phantom section: H Device Section

Measurement Standard: DASy4 (High Precision Assessment)

DASY4 Configuration:

- Probe: H3DV6 - SN6076; ; Calibrated: 10/21/2005
- Sensor-Surface: (Fix Surface)
- Electronics: DAE4 Sn541; Calibrated: 10/16/2006
- Phantom: HAC Test Arch; Type: SD HAC P01 BA; Serial:
- Measurement SW: DASy4, V4.7 Build 44; Postprocessing SW: SEMCAD, V1.8 Build 171

**H Scan - H3DV6 probe center 10mm above Device Reference/Hearing Aid Compatibility Test (101x101x1):**

Measurement grid: dx=5mm, dy=5mm

Maximum value of peak Total field = 0.279 A/m

Probe Modulation Factor = 1.08

Reference Value = 0.231 A/m; Power Drift = -0.074 dB

**Hearing Aid Near-Field Category: M3 (AWF 0 dB)**

Peak H-field in A/m

Grid 1	Grid 2	Grid 3
<b>0.267</b>	<b>0.279</b>	<b>0.240</b>
Grid 4	Grid 5	Grid 6
<b>0.269</b>	<b>0.279</b>	<b>0.212</b>
Grid 7	Grid 8	Grid 9
<b>0.245</b>	<b>0.252</b>	<b>0.141</b>

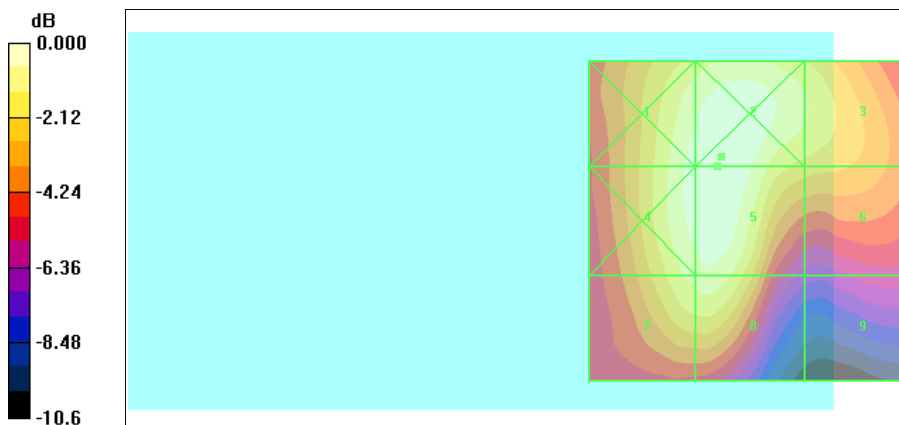



Test Laboratory: A Test Lab Techno Corp. Date/Time: 12/27/2006 12:57:04 AM

**HAC\_CDMA PCS CH1175\_802.11b CH1\_H**

**DUT: TTTA200; Type:Pocket PC Phone; FCC ID:NM8TITA100**

Communication System: CDMA PCS ; Frequency: 1908.75 MHz;Duty Cycle: 1:1

Medium parameters used:  $\sigma = 0$  mho/m,  $\epsilon_r = 1$ ;  $\rho = 1$  kg/m<sup>3</sup>

Phantom section: H Device Section

Measurement Standard: DASy4 (High Precision Assessment)

DASy4 Configuration:

- Probe: H3DV6 - SN6076; ; Calibrated: 10/21/2005
- Sensor-Surface: (Fix Surface)
- Electronics: DAE4 Sn541; Calibrated: 10/16/2006
- Phantom: HAC Test Arch; Type: SD HAC P01 BA; Serial:
- Measurement SW: DASy4, V4.7 Build 44; Postprocessing SW: SEMCAD, V1.8 Build 171

**H Scan - H3DV6 probe center 10mm above Device Reference/Hearing Aid Compatibility Test (101x101x1):**

Measurement grid: dx=5mm, dy=5mm

Maximum value of peak Total field = 0.278 A/m

Probe Modulation Factor = 1.08

Reference Value = 0.236 A/m; Power Drift = -0.156 dB

**Hearing Aid Near-Field Category: M3 (AWF 0 dB)**

Peak H-field in A/m

Grid 1	Grid 2	Grid 3
<b>0.266</b>	<b>0.277</b>	<b>0.242</b>
Grid 4	Grid 5	Grid 6
<b>0.267</b>	<b>0.278</b>	<b>0.217</b>
Grid 7	Grid 8	Grid 9
<b>0.247</b>	<b>0.253</b>	<b>0.150</b>

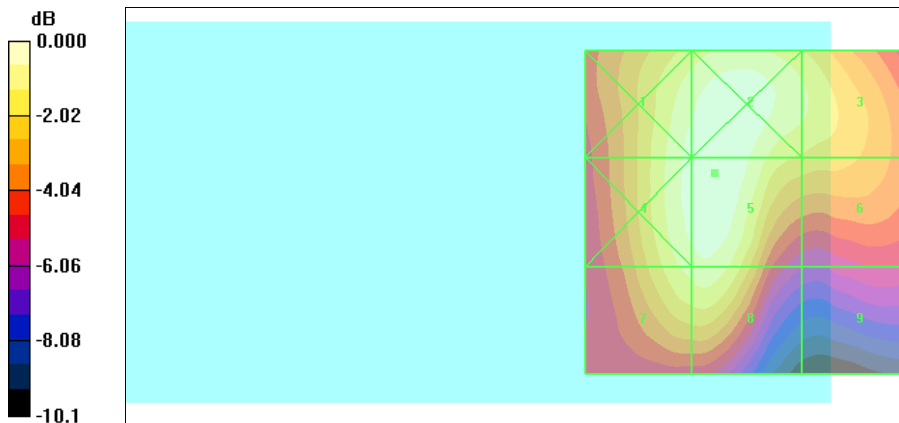





Test Laboratory: A Test Lab Techno Corp. Date/Time: 12/27/2006 1:37:40 AM

**HAC\_CDMA Cellular CH1013\_802.11g CH1\_H**

**DUT: TTTA200; Type:Pocket PC Phone; FCC ID:NM8TITA100**

Communication System: CDMA Cellular ; Frequency: 824.7 MHz;Duty Cycle: 1:1

Medium parameters used:  $\sigma = 0$  mho/m,  $\epsilon_r = 1$ ;  $\rho = 1$  kg/m<sup>3</sup>

Phantom section: H Device Section

Measurement Standard: DASYS4 (High Precision Assessment)

DASY4 Configuration:

- Probe: H3DV6 - SN6076; ; Calibrated: 10/21/2005
- Sensor-Surface: (Fix Surface)
- Electronics: DAE4 Sn541; Calibrated: 10/16/2006
- Phantom: HAC Test Arch; Type: SD HAC P01 BA; Serial:
- Measurement SW: DASYS4, V4.7 Build 44; Postprocessing SW: SEMCAD, V1.8 Build 171

**H Scan - H3DV6 probe center 10mm above Device Reference/Hearing Aid Compatibility Test (101x101x1):**

Measurement grid: dx=5mm, dy=5mm

Maximum value of peak Total field = 0.343 A/m

Probe Modulation Factor = 1.25

Reference Value = 0.203 A/m; Power Drift = -0.005 dB

**Hearing Aid Near-Field Category: M4 (AWF 0 dB)**

Peak H-field in A/m

Grid 1	Grid 2	Grid 3
<b>0.345</b>	<b>0.374</b>	<b>0.353</b>
Grid 4	Grid 5	Grid 6
<b>0.334</b>	<b>0.343</b>	<b>0.321</b>
Grid 7	Grid 8	Grid 9
<b>0.261</b>	<b>0.264</b>	<b>0.235</b>

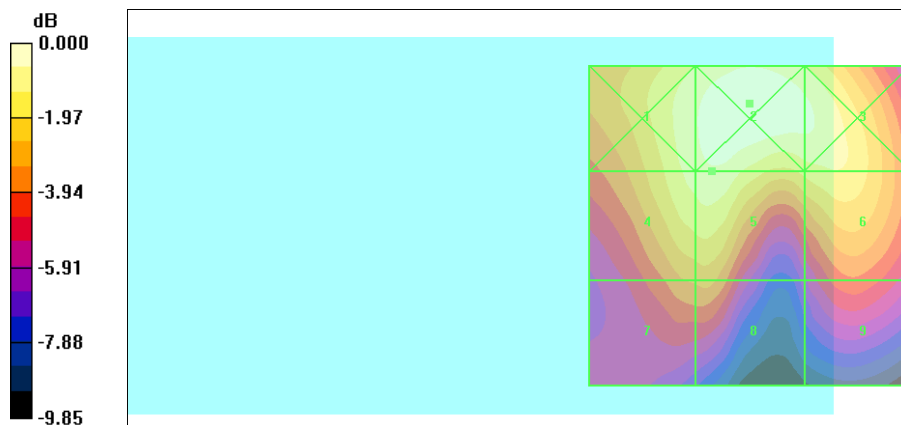

0 dB = 0.374A/m



Test Laboratory: A Test Lab Techno Corp. Date/Time: 12/27/2006 1:43:58 AM

**HAC\_CDMA Cellular CH384\_802.11g CH1\_H**

**DUT: TTTA200; Type:Pocket PC Phone; FCC ID:NM8TITA100**

Communication System: CDMA Cellular ; Frequency: 836.52 MHz;Duty Cycle: 1:1

Medium parameters used:  $\sigma = 0$  mho/m,  $\epsilon_r = 1$ ;  $\rho = 1$  kg/m<sup>3</sup>

Phantom section: H Device Section

Measurement Standard: DASy4 (High Precision Assessment)

DASY4 Configuration:

- Probe: H3DV6 - SN6076; ; Calibrated: 10/21/2005
- Sensor-Surface: (Fix Surface)
- Electronics: DAE4 Sn541; Calibrated: 10/16/2006
- Phantom: HAC Test Arch; Type: SD HAC P01 BA; Serial:
- Measurement SW: DASy4, V4.7 Build 44; Postprocessing SW: SEMCAD, V1.8 Build 171

**H Scan - H3DV6 probe center 10mm above Device Reference/Hearing Aid Compatibility Test (101x101x1):**

Measurement grid: dx=5mm, dy=5mm

Maximum value of peak Total field = 0.394 A/m

Probe Modulation Factor = 1.25

Reference Value = 0.229 A/m; Power Drift = -0.063 dB

**Hearing Aid Near-Field Category: M4 (AWF 0 dB)**

Peak H-field in A/m

Grid 1	Grid 2	Grid 3
<b>0.394</b>	<b>0.429</b>	<b>0.409</b>
Grid 4	Grid 5	Grid 6
<b>0.384</b>	<b>0.394</b>	<b>0.368</b>
Grid 7	Grid 8	Grid 9
<b>0.299</b>	<b>0.302</b>	<b>0.268</b>

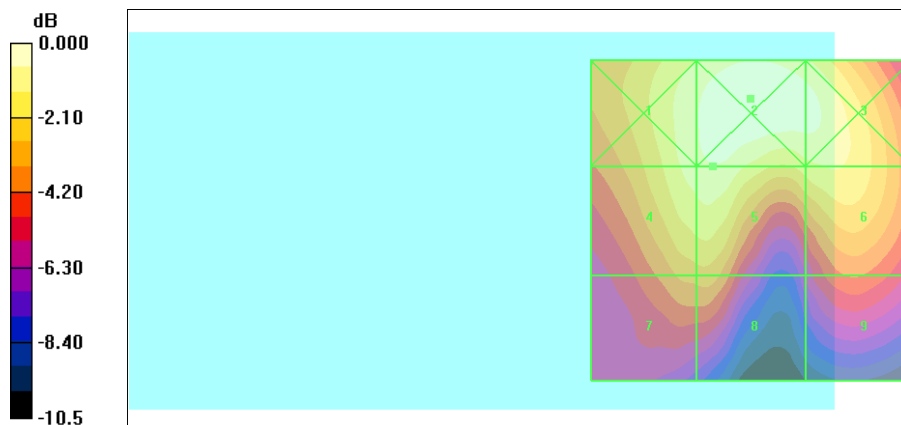

0 dB = 0.429A/m



Test Laboratory: A Test Lab Techno Corp. Date/Time: 12/27/2006 1:49:21 AM

**HAC\_CDMA Cellular CH777\_802.11g CH1\_H**

**DUT: TTTA200; Type:Pocket PC Phone; FCC ID:NM8TITA100**

Communication System: CDMA Cellular ; Frequency: 848.31 MHz;Duty Cycle: 1:1

Medium parameters used:  $\sigma = 0$  mho/m,  $\epsilon_r = 1$ ;  $\rho = 1$  kg/m<sup>3</sup>

Phantom section: H Device Section

Measurement Standard: DASYS4 (High Precision Assessment)

DASY4 Configuration:

- Probe: H3DV6 - SN6076; ; Calibrated: 10/21/2005
- Sensor-Surface: (Fix Surface)
- Electronics: DAE4 Sn541; Calibrated: 10/16/2006
- Phantom: HAC Test Arch; Type: SD HAC P01 BA; Serial:
- Measurement SW: DASYS4, V4.7 Build 44; Postprocessing SW: SEMCAD, V1.8 Build 171

**H Scan - H3DV6 probe center 10mm above Device Reference/Hearing Aid Compatibility Test (101x101x1):**

Measurement grid: dx=5mm, dy=5mm

Maximum value of peak Total field = 0.349 A/m

Probe Modulation Factor = 1.25

Reference Value = 0.206 A/m; Power Drift = 0.075 dB

**Hearing Aid Near-Field Category: M4 (AWF 0 dB)**

Peak H-field in A/m

Grid 1	Grid 2	Grid 3
<b>0.349</b>	<b>0.376</b>	<b>0.358</b>
Grid 4	Grid 5	Grid 6
<b>0.340</b>	<b>0.349</b>	<b>0.326</b>
Grid 7	Grid 8	Grid 9
<b>0.269</b>	<b>0.272</b>	<b>0.240</b>

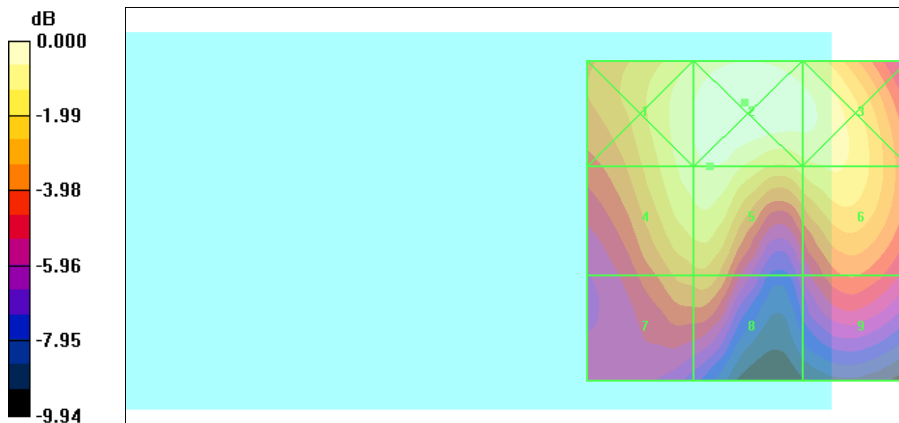



Test Laboratory: A Test Lab Techno Corp. Date/Time: 12/27/2006 1:20:14 AM

**HAC\_CDMA PCS CH25\_802.11g CH1\_H**

**DUT:TTTA200; Type:Pocket PC Phone; FCC ID:NM8TITA100**

Communication System: CDMA PCS ; Frequency: 1851.25 MHz;Duty Cycle: 1:1

Medium parameters used:  $\sigma = 0$  mho/m,  $\epsilon_r = 1$ ;  $\rho = 1$  kg/m<sup>3</sup>

Phantom section: H Device Section

Measurement Standard: DASy4 (High Precision Assessment)

DASY4 Configuration:

- Probe: H3DV6 - SN6076; ; Calibrated: 10/21/2005
- Sensor-Surface: (Fix Surface)
- Electronics: DAE4 Sn541; Calibrated: 10/16/2006
- Phantom: HAC Test Arch; Type: SD HAC P01 BA; Serial:
- Measurement SW: DASy4, V4.7 Build 44; Postprocessing SW: SEMCAD, V1.8 Build 171

**H Scan - H3DV6 probe center 10mm above Device Reference/Hearing Aid Compatibility Test (101x101x1):**

Measurement grid: dx=5mm, dy=5mm

Maximum value of peak Total field = 0.253 A/m

Probe Modulation Factor = 1.08

Reference Value = 0.209 A/m; Power Drift = -0.098 dB

**Hearing Aid Near-Field Category: M3 (AWF 0 dB)**

Peak H-field in A/m

Grid 1	Grid 2	Grid 3
<b>0.241</b>	<b>0.254</b>	<b>0.221</b>
Grid 4	Grid 5	Grid 6
<b>0.242</b>	<b>0.253</b>	<b>0.192</b>
Grid 7	Grid 8	Grid 9
<b>0.220</b>	<b>0.226</b>	<b>0.128</b>

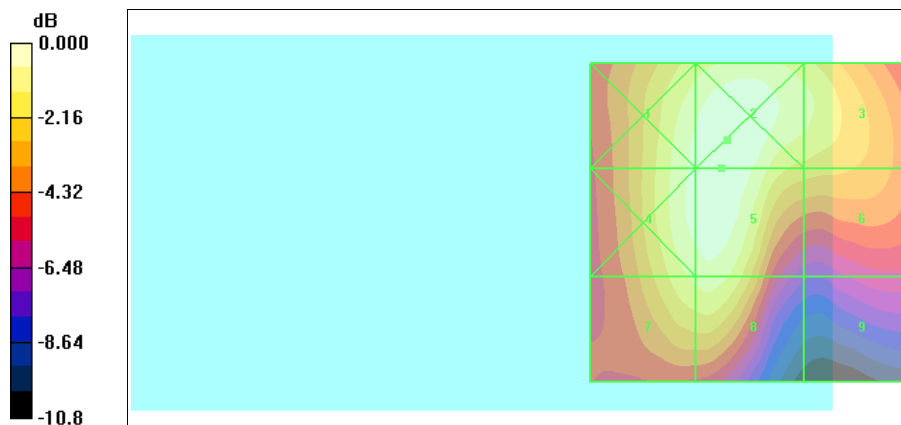

0 dB = 0.254A/m



Test Laboratory: A Test Lab Techno Corp. Date/Time: 12/27/2006 1:25:36 AM

**HAC\_CDMA PCS CH600\_802.11g CH1\_H**

**DUT: TTTA200; Type:Pocket PC Phone; FCC ID:NM8TITA100**

Communication System: CDMA PCS ; Frequency: 1880 MHz;Duty Cycle: 1:1

Medium parameters used:  $\sigma = 0$  mho/m,  $\epsilon_r = 1$ ;  $\rho = 1$  kg/m<sup>3</sup>

Phantom section: H Device Section

Measurement Standard: DASy4 (High Precision Assessment)

DASY4 Configuration:

- Probe: H3DV6 - SN6076; ; Calibrated: 10/21/2005
- Sensor-Surface: (Fix Surface)
- Electronics: DAE4 Sn541; Calibrated: 10/16/2006
- Phantom: HAC Test Arch; Type: SD HAC P01 BA; Serial:
- Measurement SW: DASy4, V4.7 Build 44; Postprocessing SW: SEMCAD, V1.8 Build 171

**H Scan - H3DV6 probe center 10mm above Device Reference/Hearing Aid Compatibility Test (101x101x1):**

Measurement grid: dx=5mm, dy=5mm

Maximum value of peak Total field = 0.279 A/m

Probe Modulation Factor = 1.08

Reference Value = 0.229 A/m; Power Drift = -0.122 dB

**Hearing Aid Near-Field Category: M3 (AWF 0 dB)**

Peak H-field in A/m

Grid 1	Grid 2	Grid 3
<b>0.266</b>	<b>0.277</b>	<b>0.238</b>
Grid 4	Grid 5	Grid 6
<b>0.267</b>	<b>0.279</b>	<b>0.212</b>
Grid 7	Grid 8	Grid 9
<b>0.244</b>	<b>0.251</b>	<b>0.139</b>

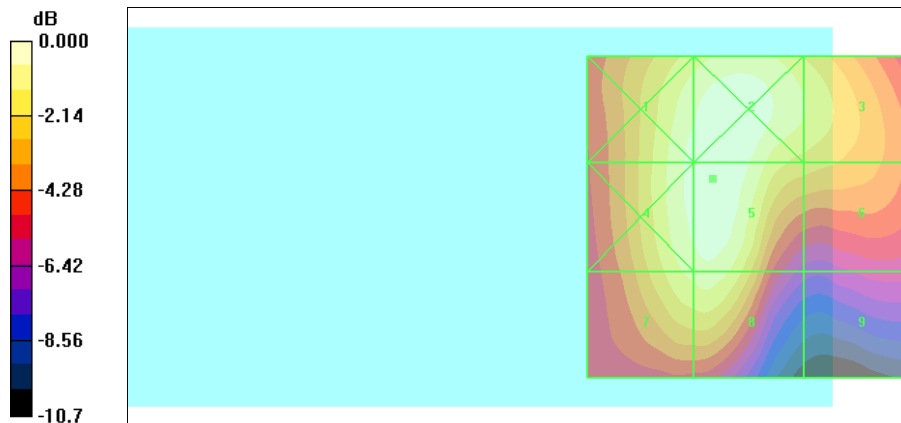

0 dB = 0.279A/m



Test Laboratory: A Test Lab Techno Corp. Date/Time: 12/27/2006 1:31:00 AM

**HAC\_CDMA PCS CH1175\_802.11g CH1\_H**

**DUT:TTTA200; Type:Pocket PC Phone; FCC ID:NM8TTTA100**

Communication System: CDMA PCS ; Frequency: 1908.75 MHz;Duty Cycle: 1:1

Medium parameters used:  $\sigma = 0$  mho/m,  $\epsilon_r = 1$ ;  $\rho = 1$  kg/m<sup>3</sup>

Phantom section: H Device Section

Measurement Standard: DASy4 (High Precision Assessment)

DASy4 Configuration:

- Probe: H3DV6 - SN6076; ; Calibrated: 10/21/2005
- Sensor-Surface: (Fix Surface)
- Electronics: DAE4 Sn541; Calibrated: 10/16/2006
- Phantom: HAC Test Arch; Type: SD HAC P01 BA; Serial:
- Measurement SW: DASy4, V4.7 Build 44; Postprocessing SW: SEMCAD, V1.8 Build 171

**H Scan - H3DV6 probe center 10mm above Device Reference/Hearing Aid Compatibility Test (101x101x1):**

Measurement grid: dx=5mm, dy=5mm

Maximum value of peak Total field = 0.269 A/m

Probe Modulation Factor = 1.08

Reference Value = 0.226 A/m; Power Drift = -0.043 dB

**Hearing Aid Near-Field Category: M3 (AWF 0 dB)**

Peak H-field in A/m

Grid 1	Grid 2	Grid 3
<b>0.256</b>	<b>0.266</b>	<b>0.234</b>
Grid 4	Grid 5	Grid 6
<b>0.258</b>	<b>0.269</b>	<b>0.212</b>
Grid 7	Grid 8	Grid 9
<b>0.238</b>	<b>0.245</b>	<b>0.146</b>

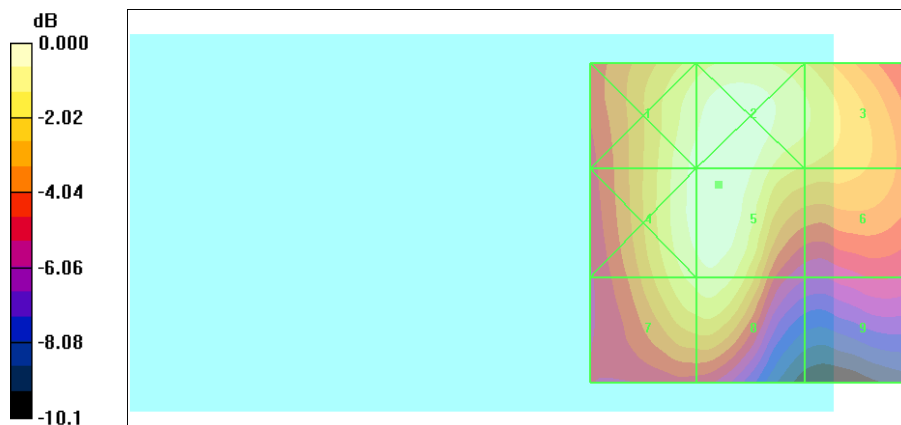



Test Laboratory: A Test Lab Techno Corp. Date/Time: 12/27/2006 2:07:29 AM

**HAC\_CDMA Cellular CH1013\_Bluetooth CH39\_H**

**DUT: TTTA200; Type:Pocket PC Phone; FCC ID:NM8TITA100**

Communication System: CDMA Cellular ; Frequency: 824.7 MHz;Duty Cycle: 1:1

Medium parameters used:  $\sigma = 0$  mho/m,  $\epsilon_r = 1$ ;  $\rho = 1$  kg/m<sup>3</sup>

Phantom section: H Device Section

Measurement Standard: DASYS4 (High Precision Assessment)

DASY4 Configuration:

- Probe: H3DV6 - SN6076; ; Calibrated: 10/21/2005
- Sensor-Surface: (Fix Surface)
- Electronics: DAE4 Sn541; Calibrated: 10/16/2006
- Phantom: HAC Test Arch; Type: SD HAC P01 BA; Serial:
- Measurement SW: DASYS4, V4.7 Build 44; Postprocessing SW: SEMCAD, V1.8 Build 171

**H Scan - H3DV6 probe center 10mm above Device Reference/Hearing Aid Compatibility Test (101x101x1):**

Measurement grid: dx=5mm,dy=5mm

Maximum value of peak Total field = 0.326 A/m

Probe Modulation Factor = 1.25

Reference Value = 0.190 A/m; Power Drift = 0.034 dB

**Hearing Aid Near-Field Category: M4 (AWF 0 dB)**

Peak H-field in A/m

Grid 1	Grid 2	Grid 3
<b>0.324</b>	<b>0.365</b>	<b>0.356</b>
Grid 4	Grid 5	Grid 6
<b>0.313</b>	<b>0.326</b>	<b>0.317</b>
Grid 7	Grid 8	Grid 9
<b>0.241</b>	<b>0.245</b>	<b>0.223</b>

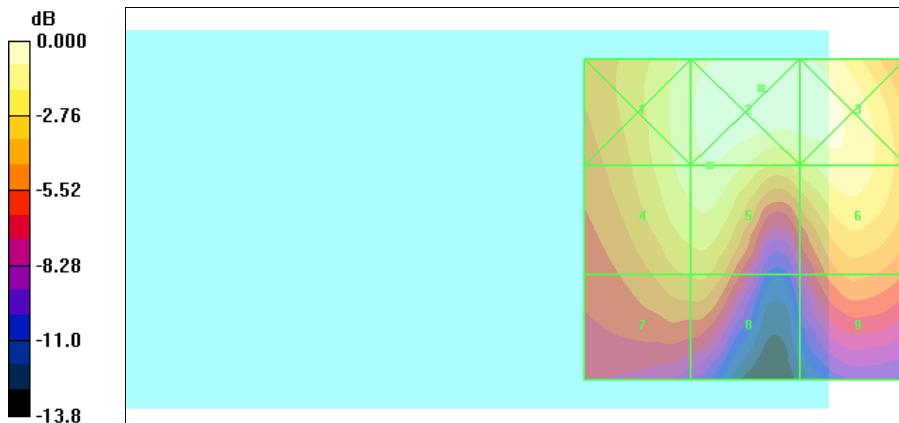

0 dB = 0.365A/m



Test Laboratory: A Test Lab Techno Corp. Date/Time: 12/27/2006 2:12:53 AM

**HAC\_CDMA Cellular CH384\_Bluetooth CH39\_H**

**DUT: TTTA200; Type:Pocket PC Phone; FCC ID:NM8TITA100**

Communication System: CDMA Cellular ; Frequency: 836.52 MHz;Duty Cycle: 1:1

Medium parameters used:  $\sigma = 0$  mho/m,  $\epsilon_r = 1$ ;  $\rho = 1$  kg/m<sup>3</sup>

Phantom section: H Device Section

Measurement Standard: DASYS4 (High Precision Assessment)

DASY4 Configuration:

- Probe: H3DV6 - SN6076; ; Calibrated: 10/21/2005
- Sensor-Surface: (Fix Surface)
- Electronics: DAE4 Sn541; Calibrated: 10/16/2006
- Phantom: HAC Test Arch; Type: SD HAC P01 BA; Serial:
- Measurement SW: DASYS4, V4.7 Build 44; Postprocessing SW: SEMCAD, V1.8 Build 171

**H Scan - H3DV6 probe center 10mm above Device Reference/Hearing Aid Compatibility Test (101x101x1):**

Measurement grid: dx=5mm, dy=5mm

Maximum value of peak Total field = 0.372 A/m

Probe Modulation Factor = 1.25

Reference Value = 0.220 A/m; Power Drift = -0.017 dB

**Hearing Aid Near-Field Category: M4 (AWF 0 dB)**

Peak H-field in A/m

Grid 1	Grid 2	Grid 3
<b>0.370</b>	<b>0.417</b>	<b>0.409</b>
Grid 4	Grid 5	Grid 6
<b>0.357</b>	<b>0.372</b>	<b>0.362</b>
Grid 7	Grid 8	Grid 9
<b>0.277</b>	<b>0.282</b>	<b>0.254</b>







Test Laboratory: A Test Lab Techno Corp. Date/Time: 12/27/2006 2:18:23 AM

**HAC\_CDMA Cellular CH777\_Bluetooth CH39\_H**

**DUT: TTTA200; Type:Pocket PC Phone; FCC ID:NM8TITA100**

Communication System: CDMA Cellular ; Frequency: 848.31 MHz;Duty Cycle: 1:1

Medium parameters used:  $\sigma = 0$  mho/m,  $\epsilon_r = 1$ ;  $\rho = 1$  kg/m<sup>3</sup>

Phantom section: H Device Section

Measurement Standard: DASYS4 (High Precision Assessment)

DASY4 Configuration:

- Probe: H3DV6 - SN6076; ; Calibrated: 10/21/2005
- Sensor-Surface: (Fix Surface)
- Electronics: DAE4 Sn541; Calibrated: 10/16/2006
- Phantom: HAC Test Arch; Type: SD HAC P01 BA; Serial:
- Measurement SW: DASYS4, V4.7 Build 44; Postprocessing SW: SEMCAD, V1.8 Build 171

**H Scan - H3DV6 probe center 10mm above Device Reference/Hearing Aid Compatibility Test (101x101x1):**

Measurement grid: dx=5mm, dy=5mm

Maximum value of peak Total field = 0.325 A/m

Probe Modulation Factor = 1.25

Reference Value = 0.193 A/m; Power Drift = -0.020 dB

**Hearing Aid Near-Field Category: M4 (AWF 0 dB)**

Peak H-field in A/m

Grid 1	Grid 2	Grid 3
<b>0.322</b>	<b>0.361</b>	<b>0.352</b>
Grid 4	Grid 5	Grid 6
<b>0.311</b>	<b>0.325</b>	<b>0.314</b>
Grid 7	Grid 8	Grid 9
<b>0.245</b>	<b>0.248</b>	<b>0.223</b>

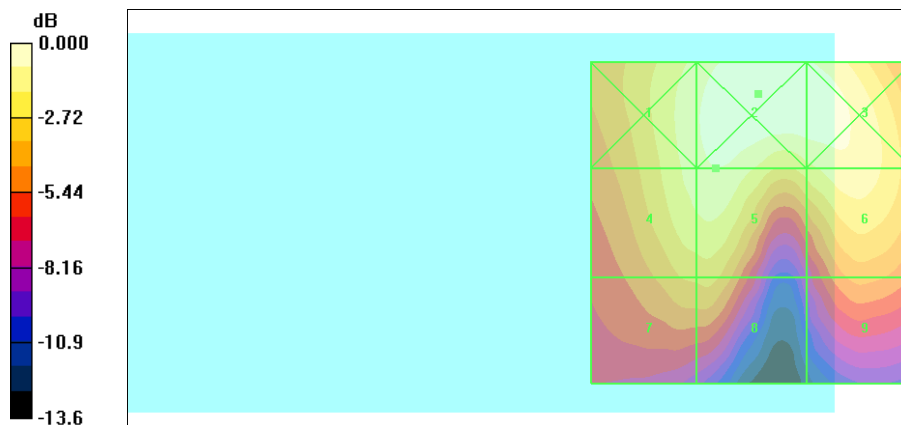

0 dB = 0.361A/m



Test Laboratory: A Test Lab Techno Corp. Date/Time: 12/27/2006 2:24:19 AM

**HAC\_CDMA PCS CH25\_Bluetooth CH39\_H**

**DUT: TTTA200; Type:Pocket PC Phone; FCC ID:NM8TITA100**

Communication System: CDMA PCS ; Frequency: 1851.25 MHz;Duty Cycle: 1:1

Medium parameters used:  $\sigma = 0$  mho/m,  $\epsilon_r = 1$ ;  $\rho = 1$  kg/m<sup>3</sup>

Phantom section: H Device Section

Measurement Standard: DASy4 (High Precision Assessment)

DASY4 Configuration:

- Probe: H3DV6 - SN6076; ; Calibrated: 10/21/2005
- Sensor-Surface: (Fix Surface)
- Electronics: DAE4 Sn541; Calibrated: 10/16/2006
- Phantom: HAC Test Arch; Type: SD HAC P01 BA; Serial:
- Measurement SW: DASy4, V4.7 Build 44; Postprocessing SW: SEMCAD, V1.8 Build 171

**H Scan - H3DV6 probe center 10mm above Device Reference/Hearing Aid Compatibility Test (101x101x1):**

Measurement grid: dx=5mm, dy=5mm

Maximum value of peak Total field = 0.229 A/m

Probe Modulation Factor = 1.08

Reference Value = 0.195 A/m; Power Drift = -0.096 dB

**Hearing Aid Near-Field Category: M3 (AWF 0 dB)**

Peak H-field in A/m

Grid 1	Grid 2	Grid 3
<b>0.215</b>	<b>0.236</b>	<b>0.218</b>
Grid 4	Grid 5	Grid 6
<b>0.215</b>	<b>0.229</b>	<b>0.178</b>
Grid 7	Grid 8	Grid 9
<b>0.189</b>	<b>0.195</b>	<b>0.121</b>

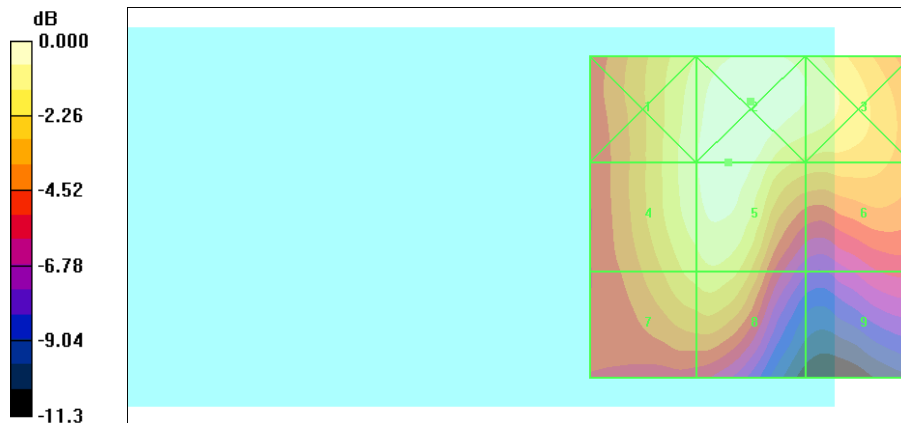

0 dB = 0.236A/m



Test Laboratory: A Test Lab Techno Corp. Date/Time: 12/27/2006 2:29:51 AM

**HAC\_CDMA PCS CH600\_Bluetooth CH39\_H**

**DUT: TTTA200; Type:Pocket PC Phone; FCC ID:NM8TITA100**

Communication System: CDMA PCS ; Frequency: 1880 MHz;Duty Cycle: 1:1

Medium parameters used:  $\sigma = 0$  mho/m,  $\epsilon_r = 1$ ;  $\rho = 1$  kg/m<sup>3</sup>

Phantom section: H Device Section

Measurement Standard: DASy4 (High Precision Assessment)

DASY4 Configuration:

- Probe: H3DV6 - SN6076; ; Calibrated: 10/21/2005
- Sensor-Surface: (Fix Surface)
- Electronics: DAE4 Sn541; Calibrated: 10/16/2006
- Phantom: HAC Test Arch; Type: SD HAC P01 BA; Serial:
- Measurement SW: DASy4, V4.7 Build 44; Postprocessing SW: SEMCAD, V1.8 Build 171

**H Scan - H3DV6 probe center 10mm above Device Reference/Hearing Aid Compatibility Test (101x101x1):**

Measurement grid: dx=5mm, dy=5mm

Maximum value of peak Total field = 0.252 A/m

Probe Modulation Factor = 1.08

Reference Value = 0.214 A/m; Power Drift = 0.012 dB

**Hearing Aid Near-Field Category: M3 (AWF 0 dB)**

Peak H-field in A/m

Grid 1	Grid 2	Grid 3
<b>0.236</b>	<b>0.257</b>	<b>0.235</b>
Grid 4	Grid 5	Grid 6
<b>0.236</b>	<b>0.252</b>	<b>0.196</b>
Grid 7	Grid 8	Grid 9
<b>0.211</b>	<b>0.218</b>	<b>0.133</b>

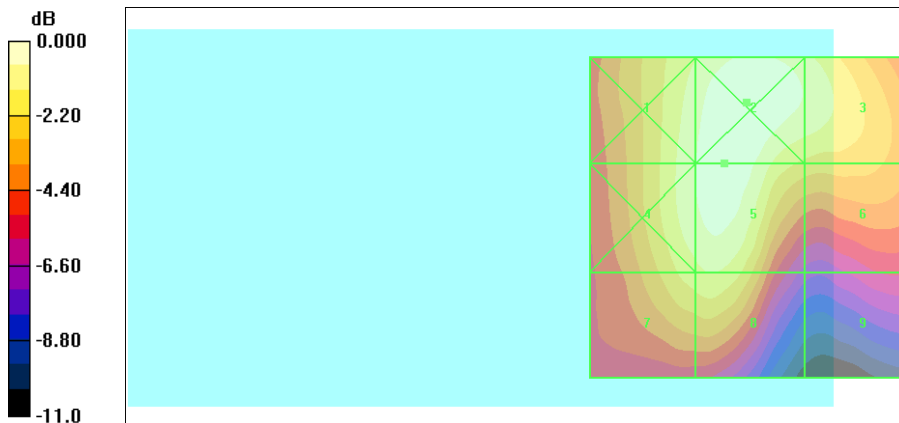



Test Laboratory: A Test Lab Techno Corp. Date/Time: 12/27/2006 2:37:33 AM

**HAC\_CDMA PCS CH1175\_Bluetooth CH39\_H**

**DUT: TTTA200; Type:Pocket PC Phone; FCC ID:NM8TITA100**

Communication System: CDMA PCS ; Frequency: 1908.75 MHz;Duty Cycle: 1:1

Medium parameters used:  $\sigma = 0$  mho/m,  $\epsilon_r = 1$ ;  $\rho = 1$  kg/m<sup>3</sup>

Phantom section: H Device Section

Measurement Standard: DASy4 (High Precision Assessment)

DASY4 Configuration:

- Probe: H3DV6 - SN6076; ; Calibrated: 10/21/2005
- Sensor-Surface: (Fix Surface)
- Electronics: DAE4 Sn541; Calibrated: 10/16/2006
- Phantom: HAC Test Arch; Type: SD HAC P01 BA; Serial:
- Measurement SW: DASy4, V4.7 Build 44; Postprocessing SW: SEMCAD, V1.8 Build 171

**H Scan - H3DV6 probe center 10mm above Device Reference/Hearing Aid Compatibility Test (101x101x1):**

Measurement grid: dx=5mm, dy=5mm

Maximum value of peak Total field = 0.249 A/m

Probe Modulation Factor = 1.08

Reference Value = 0.217 A/m; Power Drift = -0.060 dB

**Hearing Aid Near-Field Category: M3 (AWF 0 dB)**

Peak H-field in A/m

Grid 1	Grid 2	Grid 3
<b>0.234</b>	<b>0.250</b>	<b>0.233</b>
Grid 4	Grid 5	Grid 6
<b>0.234</b>	<b>0.249</b>	<b>0.200</b>
Grid 7	Grid 8	Grid 9
<b>0.212</b>	<b>0.220</b>	<b>0.139</b>

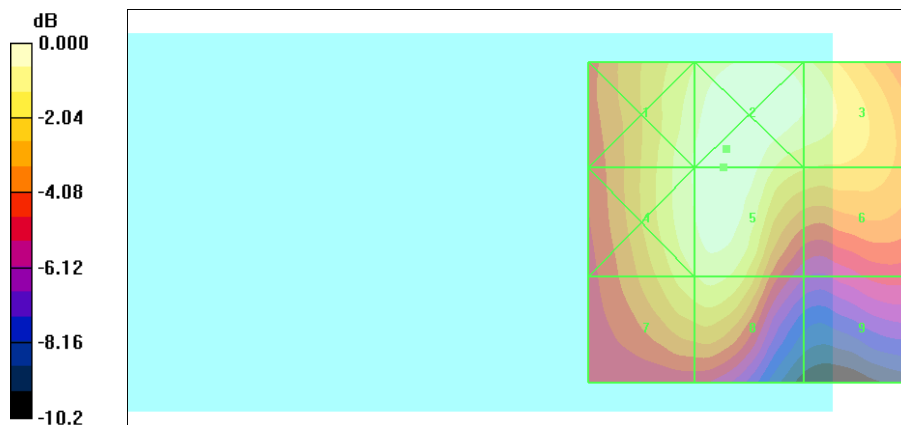

0 dB = 0.250A/m



Test Laboratory: A Test Lab Techno Corp.

Date/Time: 10/21/2006 2:13:01 PM

**802.11b CH1\_H**

**DUT: TTTA200; Type:Pocket PC Phone; FCC ID:NM8TITA100**

Communication System: IEEE 802.11b; Frequency: 2412 MHz;Duty Cycle: 1:1

Medium parameters used:  $\sigma = 0$  mho/m,  $\epsilon_r = 1$ ;  $\rho = 1$  kg/m<sup>3</sup>

Phantom section: H Device Section

Measurement Standard: DASYS4 (High Precision Assessment)

DASY4 Configuration:

- Probe: H3DV6 - SN6076; ; Calibrated: 10/21/2005
- Sensor-Surface: (Fix Surface)
- Electronics: DAE3 Sn393; Calibrated: 9/5/2006
- Phantom: HAC Test Arch; Type: SD HAC P01 BA; Serial:
- Measurement SW: DASYS4, V4.7 Build 44; Postprocessing SW: SEMCAD, V1.8 Build 171

**H Scan - H3DV6 probe center 10mm above Device Reference/Hearing Aid Compatibility Test (101x101x1):**

Measurement grid: dx=5mm, dy=5mm

Maximum value of peak Total field = 0.025 A/m

Probe Modulation Factor = 0.820

Reference Value = 0.030 A/m; Power Drift = -0.070 dB

**Hearing Aid Near-Field Category: M4 (AWF 0 dB)**

Peak H-field in A/m

Grid 1	Grid 2	Grid 3
<b>0.034</b>	<b>0.030</b>	<b>0.023</b>
Grid 4	Grid 5	Grid 6
<b>0.025</b>	<b>0.025</b>	<b>0.022</b>
Grid 7	Grid 8	Grid 9
<b>0.025</b>	<b>0.025</b>	<b>0.021</b>

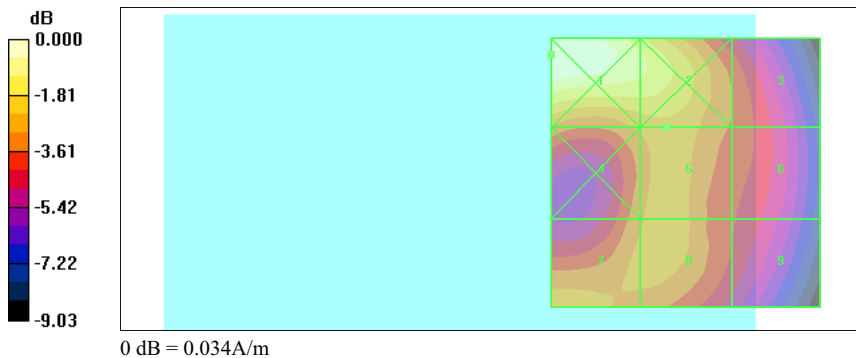



Test Laboratory: A Test Lab Techno Corp.

Date/Time: 10/21/2006 2:21:00 PM

**802.11b CH6\_H**

**DUT: TTTA200; Type:Pocket PC Phone; FCC ID:NM8TITA100**

Communication System: IEEE 802.11b; Frequency: 2437 MHz;Duty Cycle: 1:1

Medium parameters used:  $\sigma = 0$  mho/m,  $\epsilon_r = 1$ ;  $\rho = 1$  kg/m<sup>3</sup>

Phantom section: H Device Section

Measurement Standard: DASYS4 (High Precision Assessment)

DASY4 Configuration:

- Probe: H3DV6 - SN6076; ; Calibrated: 10/21/2005
- Sensor-Surface: (Fix Surface)
- Electronics: DAE3 Sn393; Calibrated: 9/5/2006
- Phantom: HAC Test Arch; Type: SD HAC P01 BA; Serial:
- Measurement SW: DASYS4, V4.7 Build 44; Postprocessing SW: SEMCAD, V1.8 Build 171

**H Scan - H3DV6 probe center 10mm above Device Reference/Hearing Aid Compatibility Test (101x101x1):**

Measurement grid: dx=5mm, dy=5mm

Maximum value of peak Total field = 0.026 A/m

Probe Modulation Factor = 0.820

Reference Value = 0.030 A/m; Power Drift = -0.027 dB

**Hearing Aid Near-Field Category: M4 (AWF 0 dB)**

Peak H-field in A/m

Grid 1	Grid 2	Grid 3
<b>0.031</b>	<b>0.028</b>	<b>0.023</b>
Grid 4	Grid 5	Grid 6
<b>0.024</b>	<b>0.026</b>	<b>0.023</b>
Grid 7	Grid 8	Grid 9
<b>0.025</b>	<b>0.026</b>	<b>0.023</b>

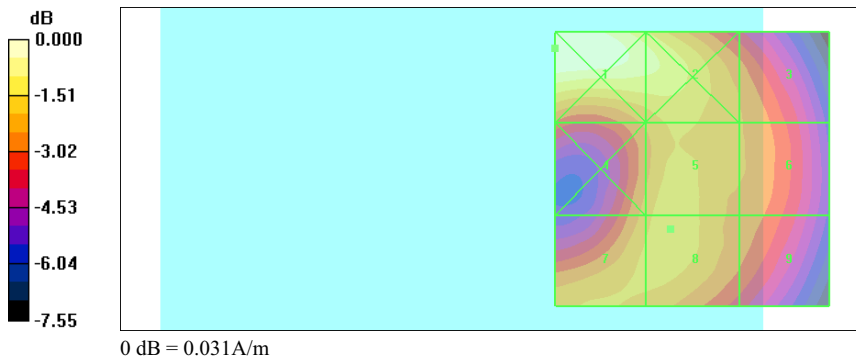



Test Laboratory: A Test Lab Techno Corp.

Date/Time: 10/21/2006 2:27:41 PM

### 802.11b CH11\_H

**DUT: TTTA200; Type:Pocket PC Phone; FCC ID:NM8TITA100**

Communication System: IEEE 802.11b; Frequency: 2462 MHz;Duty Cycle: 1:1

Medium parameters used:  $\sigma = 0$  mho/m,  $\epsilon_r = 1$ ;  $\rho = 1$  kg/m<sup>3</sup>

Phantom section: H Device Section

Measurement Standard: DASYS4 (High Precision Assessment)

DASY4 Configuration:

- Probe: H3DV6 - SN6076; ; Calibrated: 10/21/2005
- Sensor-Surface: (Fix Surface)
- Electronics: DAE3 Sn393; Calibrated: 9/5/2006
- Phantom: HAC Test Arch; Type: SD HAC P01 BA; Serial:
- Measurement SW: DASYS4, V4.7 Build 44; Postprocessing SW: SEMCAD, V1.8 Build 171

### H Scan - H3DV6 probe center 10mm above Device Reference/Hearing Aid Compatibility Test (101x101x1):

Measurement grid: dx=5mm, dy=5mm

Maximum value of peak Total field = 0.027 A/m

Probe Modulation Factor = 0.820

Reference Value = 0.031 A/m; Power Drift = -0.065 dB

**Hearing Aid Near-Field Category: M4 (AWF 0 dB)**

Peak H-field in A/m

Grid 1	Grid 2	Grid 3
<b>0.031</b>	<b>0.028</b>	<b>0.026</b>
Grid 4	Grid 5	Grid 6
<b>0.024</b>	<b>0.026</b>	<b>0.026</b>
Grid 7	Grid 8	Grid 9
<b>0.026</b>	<b>0.027</b>	<b>0.026</b>

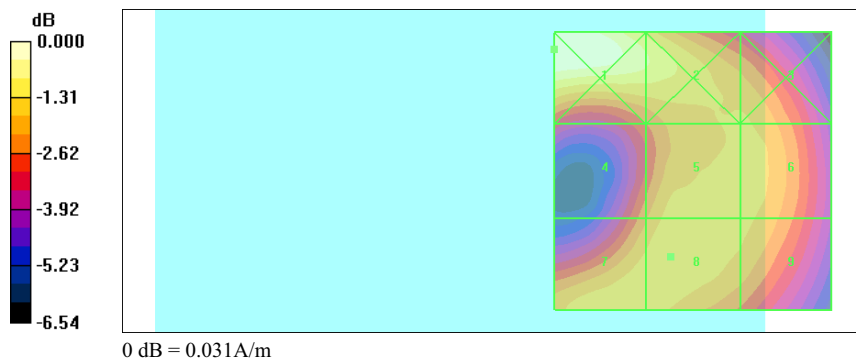



Test Laboratory: A Test Lab Techno Corp.

Date/Time: 10/21/2006 2:38:57 PM

**802.11g CH1\_H**

**DUT: TTTA200; Type:Pocket PC Phone; FCC ID:NM8TITA100**

Communication System: IEEE 802.11g; Frequency: 2412 MHz;Duty Cycle: 1:1

Medium parameters used:  $\sigma = 0$  mho/m,  $\epsilon_r = 1$ ;  $\rho = 1$  kg/m<sup>3</sup>

Phantom section: H Device Section

Measurement Standard: DASYS4 (High Precision Assessment)

DASY4 Configuration:

- Probe: H3DV6 - SN6076; ; Calibrated: 10/21/2005
- Sensor-Surface: (Fix Surface)
- Electronics: DAE3 Sn393; Calibrated: 9/5/2006
- Phantom: HAC Test Arch; Type: SD HAC P01 BA; Serial:
- Measurement SW: DASYS4, V4.7 Build 44; Postprocessing SW: SEMCAD, V1.8 Build 171

**H Scan - H3DV6 probe center 10mm above Device Reference/Hearing Aid Compatibility Test (101x101x1):**

Measurement grid: dx=5mm, dy=5mm

Maximum value of peak Total field = 0.018 A/m

Probe Modulation Factor = 0.610

Reference Value = 0.029 A/m; Power Drift = 0.198 dB

**Hearing Aid Near-Field Category: M4 (AWF 0 dB)**

Peak H-field in A/m

Grid 1	Grid 2	Grid 3
<b>0.022</b>	<b>0.021</b>	<b>0.016</b>
Grid 4	Grid 5	Grid 6
<b>0.017</b>	<b>0.018</b>	<b>0.016</b>
Grid 7	Grid 8	Grid 9
<b>0.018</b>	<b>0.017</b>	<b>0.014</b>

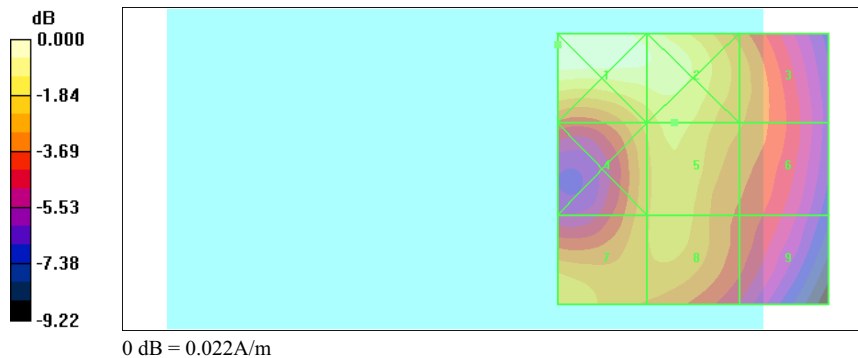





Test Laboratory: A Test Lab Techno Corp.

Date/Time: 10/21/2006 2:51:44 PM

**802.11g CH6\_H**

**DUT: TTTA200; Type:Pocket PC Phone; FCC ID:NM8TITA100**

Communication System: IEEE 802.11g; Frequency: 2437 MHz;Duty Cycle: 1:1

Medium parameters used:  $\sigma = 0$  mho/m,  $\epsilon_r = 1$ ;  $\rho = 1$  kg/m<sup>3</sup>

Phantom section: H Device Section

Measurement Standard: DAS4 (High Precision Assessment)

DASY4 Configuration:

- Probe: H3DV6 - SN6076; ; Calibrated: 10/21/2005
- Sensor-Surface: (Fix Surface)
- Electronics: DAE3 Sn393; Calibrated: 9/5/2006
- Phantom: HAC Test Arch; Type: SD HAC P01 BA; Serial:
- Measurement SW: DASY4, V4.7 Build 44; Postprocessing SW: SEMCAD, V1.8 Build 171

**H Scan - H3DV6 probe center 10mm above Device Reference/Hearing Aid Compatibility Test (101x101x1):**

Measurement grid: dx=5mm, dy=5mm

Maximum value of peak Total field = 0.019 A/m

Probe Modulation Factor = 0.610

Reference Value = 0.030 A/m; Power Drift = -0.142 dB

**Hearing Aid Near-Field Category: M4 (AWF 0 dB)**

Peak H-field in A/m

Grid 1	Grid 2	Grid 3
<b>0.023</b>	<b>0.020</b>	<b>0.017</b>
Grid 4	Grid 5	Grid 6
<b>0.018</b>	<b>0.019</b>	<b>0.017</b>
Grid 7	Grid 8	Grid 9
<b>0.018</b>	<b>0.019</b>	<b>0.017</b>

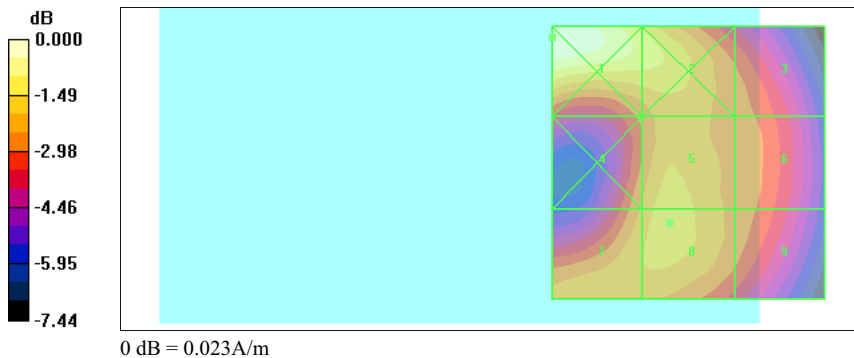



Test Laboratory: A Test Lab Techno Corp.

Date/Time: 10/21/2006 2:58:39 PM

**802.11g CH11\_H**

**DUT: TTTA200; Type:Pocket PC Phone; FCC ID:NM8TITA100**

Communication System: IEEE 802.11g; Frequency: 2462 MHz;Duty Cycle: 1:1

Medium parameters used:  $\sigma = 0$  mho/m,  $\epsilon_r = 1$ ;  $\rho = 1$  kg/m<sup>3</sup>

Phantom section: H Device Section

Measurement Standard: DASYS4 (High Precision Assessment)

DASY4 Configuration:

- Probe: H3DV6 - SN6076; ; Calibrated: 10/21/2005
- Sensor-Surface: (Fix Surface)
- Electronics: DAE3 Sn393; Calibrated: 9/5/2006
- Phantom: HAC Test Arch; Type: SD HAC P01 BA; Serial:
- Measurement SW: DASYS4, V4.7 Build 44; Postprocessing SW: SEMCAD, V1.8 Build 171

**H Scan - H3DV6 probe center 10mm above Device Reference/Hearing Aid Compatibility Test (101x101x1):**

Measurement grid: dx=5mm,dy=5mm

Maximum value of peak Total field = 0.019 A/m

Probe Modulation Factor = 0.610

Reference Value = 0.030 A/m; Power Drift = -0.071 dB

**Hearing Aid Near-Field Category: M4 (AWF 0 dB)**

Peak H-field in A/m

Grid 1	Grid 2	Grid 3
<b>0.023</b>	<b>0.020</b>	<b>0.018</b>
Grid 4	Grid 5	Grid 6
<b>0.017</b>	<b>0.019</b>	<b>0.019</b>
Grid 7	Grid 8	Grid 9
<b>0.019</b>	<b>0.019</b>	<b>0.019</b>

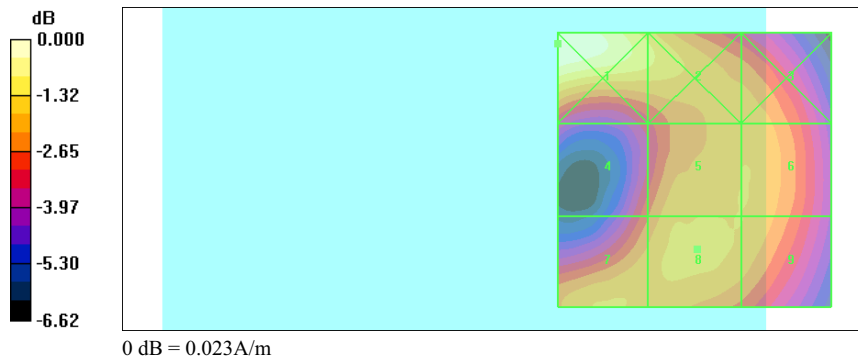



## ***Appendix E - Calibration***

All of the instruments Calibration information are listed below.

- Dipole \_ CD835V3 SN:1017 Calibration No.CD835V3-1017\_Sep05
- Dipole \_ CD1880V3 SN:1036 Calibration No.CD1880V3-1036\_ Sep05
- Dipole \_ CD2450V3 SN:1037 Calibration No.CD2450V3-1037\_ Sepr05
- Probe \_ ER3DV6 SN:2256 Calibration No. ER3-2256\_Oct05
- Probe \_ H3DV6 SN:6076 Calibration No. H3-6076\_Oct05
- DAE \_ DAE3 SN:393 Calibration No.DAE3-393\_Sep06