

SAR TEST REPORT

Equipment Under Test	PDA phone
Model Name	SAPP100
Company Name	HTC Corporation
Company Address	No.23, Xinghua Rd., Taoyuan City, Taoyuan County 330, Taiwan, R.O.C.
Date of Receipt	2008.10.09
Date of Test(s)	2008.11.25-2008.12.02,2009.01.10-2009.01.11
Date of Issue	2009.02.12

Standards:

**FCC OET Bulletin 65 supplement C,
ANSI/IEEE C95.1, C95.3, IEEE 1528**

In the configuration tested, the EUT complied with the standards specified above.

Remarks:

This report details the results of the testing carried out on one sample, the results contained in this test report do not relate to other samples of the same product. The manufacturer should ensure that all products in series production are in conformity with the product sample detailed in this report.

This report may only be reproduced and distributed in full. If the product in this report is used in any configuration other than that detailed in the report, the manufacturer must ensure the new system complies with all relevant standards. Any mention of SGS Taiwan Electronic & Communication Laboratory or testing done by SGS Taiwan Electronic & Communication Laboratory in connection with distribution or use of the product described in this report must be approved by SGS Taiwan Electronic & Communication Laboratory in writing.

Tested by : Ricky Huang Date : 2009.02.03
Asst. Supervisor

Approved by : Robert Chang Date : 2009.02.12
Tech Manager

Contents

1. General Information	3
1.1 Testing Laboratory	3
1.2 Details of Applicant.....	3
1.3 Description of EUT.....	3
1.4 Test Environment	6
1.5 Operation description.....	6
1.6 Positioning Procedure	7
1.7 EVALUATION PROCEDURES.....	8
1.8 The SAR Measurement System	10
1.9 System Components	12
1.10 SAR System Verification	14
1.11 Tissue Simulant Fluid for the Frequency Band	16
1.12 Test Standards and Limits.....	18
2. Summary of Results	20
3. Instruments List.....	29
4. Measurements	30
5. System Verification	105
6. DAE & Probe Calibration certificate.....	120
7. Uncertainty Analysis	130
8. Phantom description	131
9. System Validation from Original equipment supplier	132

1. General Information

1.1 Testing Laboratory

SGS Taiwan Ltd. Electronics & Communication Laboratory	
134, Wu Kung Road, Wuku industrial zone	
Taipei county, Taiwan, R.O.C.	
Telephone	+886-2-2299-3279
Fax	+886-2-2298-0488
Internet	http://www.tw.sgs.com/

1.2 Details of Applicant

Company Name	HTC Corporation
Company Address	No. 23 Xinghua Rd., Taoyuan City, Taoyuan County 330, Taiwan, ROC
Contact Person	Kelven Ko
TEL	+886-3-375-3252
Fax	+886-3-375-5530
E-mail	Kelven_Ko@htc.com

1.3 Description of EUT

EUT Name	PDA phone
FCC ID	NM8SPRV
Model Name	SAPP100
Brand Name	HTC
IMEI Code	Original solution :354059020016778 Second solution :354059020022172
Mode of Operation	GSM /GPRS/EDGE band

Definition	Production unit	
Modulation Mode	GSM/GMSK/8PSK	
Duty Cycle	GSM	GPRS
	1/8	1/2
Maximum RF Conducted Power (Average)	GSM 850	GSM1900
	33.7dbm	30.8dbm
TX Frequency Range (MHz)	GSM 850	GSM1900
	824.2-848.8	1850-1910
Channel Number (ARFCN)	GSM 850	GSM1900
	128-251	512-810
Battery Type	3.7 V Lithium-Ion	
Antenna Type	Internal Antenna	
Declaration	Second solution(change Camera & LCM)	
	Besides original components, this SAPP100 also changed another Camera & LCM component. In order to find SAR value whether the same between original and second solution, we used spot-check method to check it. The result of GSM850/ 1900/WALN 802.11 b/g are within 20% deviation.	
	Third solution(change Metal Button)	
		Besides original components, this SAPP100 also changed another Metal Button component. In order to find SAR value whether the same between original and third solution, we used spot-check method to check it. The result of GSM850/ 1900/WALN 802.11 b/g are within 20% deviation.

	Fourth solution(change Metal Button)	
	With the second solution sample(camera and LCM changed), this SAPP100 also changed another Metal Button component. In order to find SAR value whether the same between original and fourth solution, we used spot-check method to check it. The result of GSM850/1900/WALN 802.11 b/g are within 20% deviation.	
Max. SAR Measured (1 g)	Original solution	
	Head	Body
	0.675 mW/g (At GSM1900 Left Head (Cheek Position)_ 810 Channel)	0.968 mW/g (At GSM 1900 Body 512 Channel_repeated with WLAN802.11 b active)
	Second solution	
	Head	Body
	0.783 mW/g (At GSM1900 Left Head (Cheek Position)_ 810 Channel)	0.973 mW/g (At GSM 1900 Body 512 Channel_repeated with WLAN802.11 b active)
	Third solution	
	Head	Body
	0.73mW/g (At GSM1900 Left Head (Cheek Position)_ 810 Channel)	0.928mW/g (At GSM 1900 Body 512 Channel_repeated with WLAN802.11 b active)
	fourth solution	
	Head	Body
	0.749mW/g (At GSM1900 Left Head (Cheek Position)_ 810 Channel)	0.953mW/g (At GSM 1900 Body 512 Channel_repeated with WLAN802.11 b active)

Note:

1. EGPRS mode was not measured because maximum averaged output power is 3 dB lower in EGPRS than in GPRS mode.

1.4 Test Environment

Ambient Temperature: $22 \pm 2^\circ \text{C}$

Tissue Simulating Liquid: $22 \pm 2^\circ \text{C}$

1.5 Operation description

General:

1. For GSM & WCDMA connection: The EUT is controlled by using a Radio Communication Tester (R&S CMU200), and the communication between the EUT and the tester is established by air link. The WLAN part is controlled by chip specific software to make WLAN active. Measurements are performed respectively on the lowest, middle and highest channels of the operating band(s). The EUT is set to maximum power level during all tests, and at the beginning of each test the battery is fully charged.
2. For WLAN802.11 b/g radiation: Use specific software of chipset to control the EUT, and makes it transmit in maximum power.
3. During the SAR testing, the DASY4 system checks power drift by comparing the e-field strength of one specific location measured at the beginning with that measured at the end of the SAR testing.
4. Testing Head SAR at lowest, middle and highest channel for all bands with LET/LEC/RET/REC conditions.
5. Testing body-worn SAR by separating **1.5cm** between the back of the EUT and the flat phantom in GPRS mode.

Additional configuration(Head):

6. Testing SAR with dominant transmitter ON and co-located Bluetooth transmitter both ON for head-position worst case configuration.
7. For highest SAR configuration in this band repeated with external Memory card inside.
8. For highest SAR configuration in this band repeated with WLAN802.11 b active.

9. For highest SAR configuration in this band repeated with WLAN802.11 g active.
10. For highest SAR configuration in this band repeated with Bluetooth & WLAN802.11 b active.
11. For highest SAR configuration in this band repeated with WELLDONE Battery.

Additional configuration(Body):

12. Testing body-worn SAR with Handset and with Bluetooth transmitter OFF by separating **1.5cm** between the front of the EUT and the flat phantom in GPRS mode.
13. Testing body-worn SAR with Handset and with Bluetooth transmitter ON in GPRS mode at the body-worn worst case configuration.
14. For highest SAR configuration in this band repeated with external Memory card inside.
15. For highest SAR configuration in this band repeated with WLAN802.11 b active.
16. For highest SAR configuration in this band repeated with WLAN802.11 g active.
17. For highest SAR configuration in this band repeated with Bluetooth & WLAN802.11 b active.
18. For highest SAR configuration in this band repeated with WELLDONE Battery.

1.6 Positioning Procedure

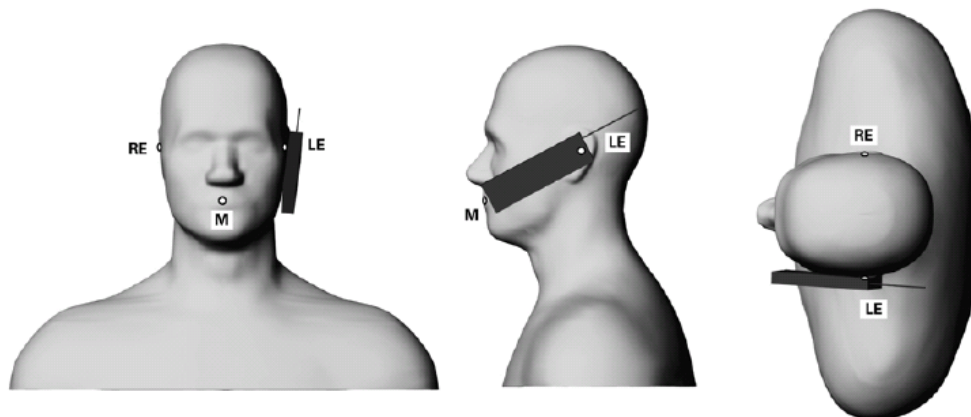

Phone position 1, "cheek" or "touch" position. The reference points for the right ear (RE), left ear (LE) and mouth (M), which define the reference plane for phone positioning

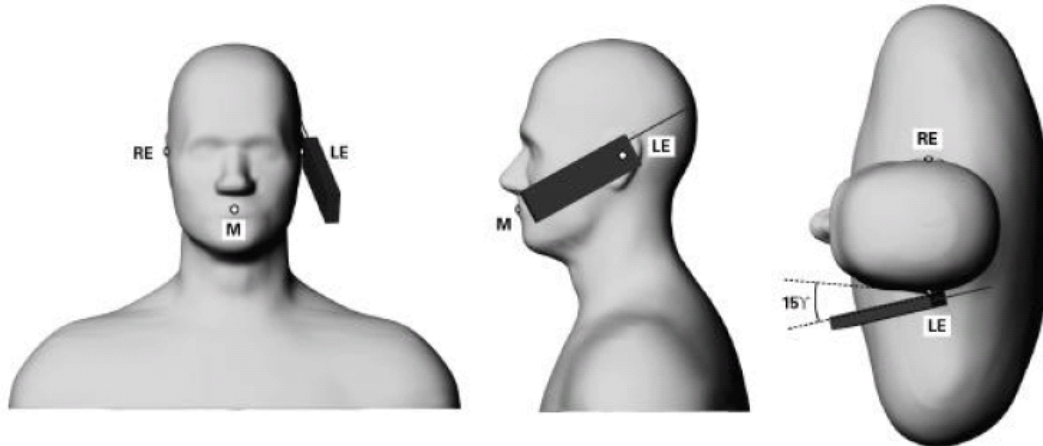

Phone position 2, "tilted position." The reference points for the right ear (RE), left ear (LE) and mouth (M), which define the reference plane for phone positioning

Cheek/Touch Position:

the handset was brought toward the mouth of the head phantom by pivoting against the ear reference point until any point of the mouthpiece or keypad touched the phantom.

Ear/Tilt Position:

With the phone aligned in the Cheek/Touch position, the handset was tilted away from the mouth with respect to the test device reference point by 15 degrees.

1.7 EVALUATION PROCEDURES

The entire evaluation of the spatial peak values is performed within the Post-processing engine (SEMCAD). The system always gives the maximum values for the 1 g and 10 g cubes. The algorithm to find the cube with highest averaged SAR is divided into the following stages:

1. The extraction of the measured data (grid and values) from the Zoom Scan.
2. The calculation of the SAR value at every measurement point based on all stored data (A/D values and measurement parameters)
3. The generation of a high-resolution mesh within the measured volume
4. The interpolation of all measured values from the measurement grid to the high-resolution grid
5. The extrapolation of the entire 3-D field distribution to the phantom surface over the distance from sensor to surface

6. The calculation of the averaged SAR within masses of 1g and 10g.

The probe is calibrated at the center of the dipole sensors that is located 1 to 2.7mm away from the probe tip. During measurements, the probe stops shortly above the phantom surface, depending on the probe and the surface detecting system. Both distances are included as parameters in the probe configuration file. The software always knows exactly how far away the measured point is from the surface. As the probe cannot directly measure at the surface, the values between the deepest measured point and the surface must be extrapolated. The angle between the probe axis and the surface normal line is less than 30 degree.

In the Area Scan, the gradient of the interpolation function is evaluated to find all the extreme of the SAR distribution. The uncertainty on the locations of the extreme is less than 1/20 of the grid size. Only local maximum within -2 dB of the global maximum are searched and passed for the Cube Scan measurement. In the Cube Scan, the interpolation function is used to extrapolate the Peak SAR from the lowest measurement points to the inner phantom surface (the extrapolation distance). The uncertainty increases with the extrapolation distance. To keep the uncertainty within 1% for the 1 g and 10 g cubes, the extrapolation distance should not be larger than 5mm.

The maximum search is automatically performed after each area scan measurement. It is based on splines in two or three dimensions. The procedure can find the maximum for most SAR distributions even with relatively large grid spacing. After the area scanning measurement, the probe is automatically moved to a position at the interpolated maximum. The following scan can directly use this position for reference, e.g., for a finer resolution grid or the cube evaluations. The 1g and 10g peak evaluations are only available for the predefined cube 7x7x7 scans.

The routines are verified and optimized for the grid dimensions used in these cube measurements. The measured volume of 30x30x30mm contains about 30g of tissue. The first procedure is an extrapolation (incl. Boundary correction) to get the points between the lowest measured plane and the surface. The next step uses 3D interpolation to get all points within the measured volume. In the last step, a 1g cube is placed numerically into the volume and its averaged SAR is calculated. This cube is the moved around until the highest averaged SAR is found.

If the highest SAR is found at the edge of the measured volume, the system will issue a warning: higher SAR values might be found outside of the measured volume. In that case the cube measurement can be repeated, using the new interpolated maximum as the center.

1.8 The SAR Measurement System

A photograph of the SAR measurement System is given in Fig. a. This SAR Measurement System uses a Computer-controlled 3-D stepper motor system (SPEAG DASY 4 professional system). A Model EX3DV3 field probe is used to determine the internal electric fields. The SAR can be obtained from the equation $SAR = \sigma (|E_i|^2) / \rho$ where σ and ρ are the conductivity and mass density of the tissue-simulant.

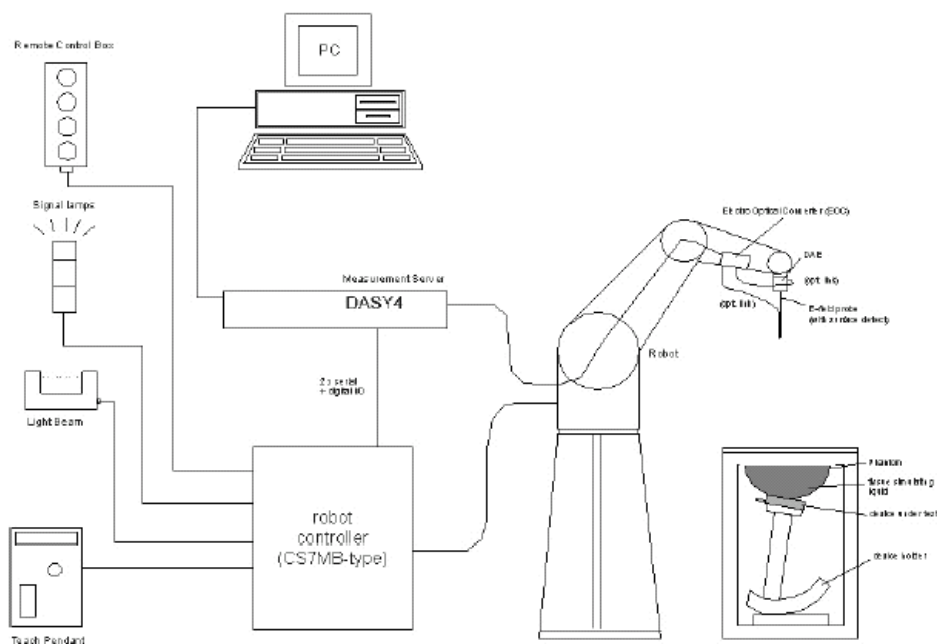

Fig.a The block diagram of SAR system

The DASY4 system for performing compliance tests consists of the following items:

- A standard high precision 6-axis robot (Staubli RX family) with controller, teach pendant and software. An arm extension is for accommodating the data acquisition electronics (DAE).

- A dosimetric probe, i.e., an isotropic E-field probe optimized and calibrated for usage in tissue simulating liquid. The probe is equipped with an optical surface detector system.
- A data acquisition electronics (DAE) which performs the signal amplification, signal multiplexing, AD-conversion, offset measurements, mechanical surface detection, collision detection, etc. The unit is battery powered with standard or rechargeable batteries. The signal is optically transmitted to the EOC.
- The Electro-optical converter (EOC) performs the conversion between optical and electrical of the signals for the digital communication to the DAE and for the analog signal from the optical surface detection. The EOC is connected to the measurement server.
- The function of the measurement server is to perform the time critical tasks such as signal filtering, control of the robot operation and fast movement interrupts.
- A probe alignment unit which improves the (absolute) accuracy of the probe positioning.
 - A computer operating Windows 2000 or Windows XP.
 - DASY4 software.
- Remote control with teach pendant and additional circuitry for robot safety such as warning lamps, etc.
- The SAM twin phantom enabling testing left-hand and right-hand usage.
- The device holder for handheld mobile phones.
- Tissue simulating liquid mixed according to the given recipes.
- Validation dipole kits allowing to validate the proper functioning of the system.

1.9 System Components

EX3DV3 E-Field Probe

Construction:	Symmetrical design with triangular core Built-in shielding against static charges PEEK enclosure material (resistant to organic solvents, e.g., DGBE)	
Calibration:	Basic Broad Band Calibration in air Conversion Factors (CF) for HSL850/1900/2450 Additional CF for other liquids and frequencies upon request	EX3DV3 E-Field Probe
Frequency:	10 MHz to > 6 GHz; Linearity: ± 0.2 dB (30 MHz to 6 GHz)	
Directivity:	± 0.3 dB in HSL (rotation around probe axis) ± 0.5 dB in tissue material (rotation normal to probe axis)	
Dynamic Range:	10 μ W/g to > 100 mW/g; Linearity: ± 0.2 dB (noise: typically < 1 μ W/g)	
Dimensions:	Overall length: 330 mm (Tip: 20 mm) Tip diameter: 2.5 mm (Body: 12 mm) Typical distance from probe tip to dipole centers: 1 mm	
Application:	High precision dosimetric measurements in any exposure scenario (e.g., very strong gradient fields). Only probe which enables compliance testing for frequencies up to 6 GHz with precision of better 30%.	

SAM PHANTOM V4.0C

Construction:	<p>The shell corresponds to the specifications of the Specific Anthropomorphic Mannequin (SAM) phantom defined in IEEE 1528-200X, CENELEC 50361 and IEC 62209.</p> <p>It enables the dosimetric evaluation of left and right hand phone usage as well as body mounted usage at the flat phantom region. A cover prevents evaporation of the liquid. Reference markings on the phantom allow the complete setup of all predefined phantom positions and measurement grids by manually teaching three points with the robot.</p>	
Shell Thickness:	2 ± 0.2 mm	
Filling Volume:	Approx. 25 liters	
Dimensions:	<p>Height: 251 mm; Length: 1000 mm; Width: 500 mm</p>	

DEVICE HOLDER

Construction	<p>In combination with the Twin SAM Phantom V4.0/V4.0C or Twin SAM, the Mounting Device (made from POM) enables the rotation of the mounted transmitter in spherical coordinates, whereby the rotation point is the ear opening. The devices can be easily and accurately positioned according to IEC, IEEE, CENELEC, FCC or other specifications. The device holder can be locked at different phantom locations (left head, right head, flat phantom).</p>	 <p style="text-align: center;">Device Holder</p>
--------------	--------------------------------------------------------------------------------------------------------------------------------------------------------------------------------------------------------------------------------------------------------------------------------------------------------------------------------------------------------------------------------------------------------------------------------------------------------------	----------------------------------------------------------------------------------------------------------------------------------------

1.10 SAR System Verification

The microwave circuit arrangement for system verification is sketched in Fig. b. The daily system accuracy verification occurs within the flat section of the SAM phantom. A SAR measurement was performed to see if the measured SAR was within +/- 5% from the target SAR values. These tests were done at 850/1900/2450 MHz. The tests were conducted on the same days as the measurement of the DUT. The obtained results from the system accuracy verification are displayed in the table 1. During the tests, the ambient temperature of the laboratory was in the range 22.2°C, the relative humidity was in the range 62% and the liquid depth above the ear reference points was above 15 cm in all the cases. It is seen that the system is operating within its specification, as the results are within acceptable tolerance of the reference values.

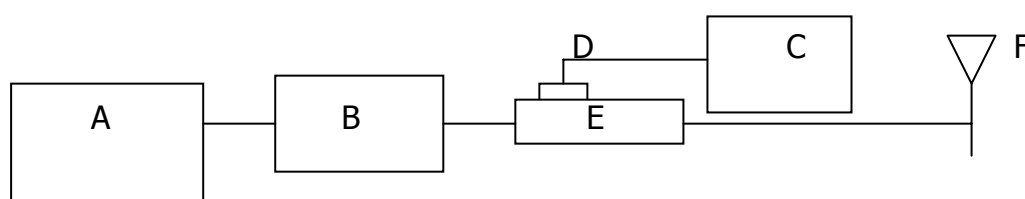

Fig.b The microwave circuit arrangement used for SAR system verification

- A. Agilent Model 8648D Signal Generator
- B. Mini circuits Model ZHL-42 Amplifier
- C. Agilent Model E4416A Power Meter
- D. Agilent Model 8481H Power Sensor
- E. Agilent Model 778D & 777D Dual directional coupling
- F. Reference dipole antenna



Photograph of the dipole Antenna

Validation Kit	Frequency (MHz)	Target SAR (1g) (Pin=250mW)	Measured SAR (1g)	Variation	Measured Date
D835V2 S/N: 4d063	835 MHz (Head)	2.29 mW/g	2.4 mW/g	4.8%	2008/11/25
D835V2 S/N: 4d063	835 MHz (Body)	2.44 mW/g	2.48 mW/g	1.6%	2008/11/25
D1900V2 S/N: 5d027	1900 MHz (Head)	10.3 mW/g	10.2 mW/g	1%	2008/11/26
D1900V2 S/N: 5d027	1900 MHz (Body)	9.64 mW/g	9.53 mW/g	1.1%	2008/11/26
D2450V2 S/N: 727	2450 MHz (Body)	13.2 mW/g	13.1 mW/g	0.7%	2008/11/26
D835V2 S/N: 4d063	835 MHz (Head)	2.29 mW/g	2.38 mW/g	3.9%	2008/12/2
D835V2 S/N: 4d063	835 MHz (Body)	2.44 mW/g	2.53 mW/g	3.6%	2008/12/2
D1900V2 S/N: 5d027	1900 MHz (Head)	10.3 mW/g	10.1 mW/g	1.9%	2008/12/2
D1900V2 S/N: 5d027	1900 MHz (Body)	9.64 mW/g	9.79 mW/g	1.5%	2008/12/2
D2450V2 S/N: 727	2450 MHz (Body)	13.2 mW/g	13.7 mW/g	3.7%	2008/12/2
D835V2 S/N: 4d063	835 MHz (Head)	2.29 mW/g	2.38 mW/g	3.9%	2009/01/10
D835V2 S/N: 4d063	835 MHz (Body)	2.44 mW/g	2.36 mW/g	3.3%	2009/01/11
D1900V2 S/N: 5d027	1900 MHz (Head)	10.3 mW/g	10.5 mW/g	1.9%	2009/01/10
D1900V2 S/N: 5d027	1900 MHz (Body)	9.64 mW/g	9.29 mW/g	3.6%	2009/01/11
D2450V2 S/N: 727	2450 MHz (Body)	13.2 mW/g	13.8 mW/g	4.5%	2009/01/11

Table 1. System validation (follow manufacture target value)

1.11 Tissue Simulant Fluid for the Frequency Band

The dielectric properties for this Head-simulant fluid were measured by using the HP Model 85070D Dielectric Probe (rates frequency band 200 MHz to 20 GHz) in conjunction with HP 8753D Network Analyzer (30 KHz-6000MHz) by using a procedure detailed in Section V.

All dielectric parameters of tissue simulates were measured within 24 hours of SAR measurements. The depth of the tissue simulant in the ear reference point of the phantom was 15cm±5mm during all tests. (Appendix Fig .2)

Frequency (MHz)	Tissue type	Measurement date/ Limits	Dielectric Parameters		
			ρ	σ (S/m)	Simulated Tissue Temperature(° C)
850	Head	Measured, 2008.11.25	42.1	0.908	21.7
		Recommended Limits	38.38-42.4	0.84-0.92	20-24
850	Body	Measured, 2008.11.25	54.3	0.945	21.7
		Recommended Limits	50.73-56.07	0.94-1.04	20-24
1900	Head	Measured, 2008.11.26	41.2	1.42	21.7
		Recommended Limits	38.1-42.11	1.4-1.54	20-24
1900	Body	Measured, 2008.11.26	51.1	1.57	21.7
		Recommended Limits	48.83-53.97	1.48-1.64	20-24
2450	Body	Measured, 2008.11.25	52.7	1.94	21.7
		Recommended Limits	48.36-53.45	1.88-2.08	20-24
850	Head	Measured, 2008.11.25	42.1	0.895	21.7
		Recommended Limits	38.38-42.4	0.84-0.92	20-24
850	Body	Measured, 2008.11.25	54.2	0.943	21.7
		Recommended Limits	50.73-56.07	0.94-1.04	20-24
1900	Head	Measured, 2008.11.26	41.3	1.42	21.7
		Recommended Limits	38.1-42.11	1.4-1.54	20-24
1900	Body	Measured, 2008.11.26	51.1	1.58	21.7
		Recommended Limits	48.83-53.97	1.48-1.64	20-24

2450	Body	Measured, 2008.11.25	53	2.05	21.7
		Recommended Limits	48.36-53.45	1.88-2.08	20-24
850	Head	Measured, 2009.01.10	42.2	0.897	21.7
		Recommended Limits	38.38-42.4	0.84-0.92	20-24
850	Body	Measured, 2009.01.11	54.3	0.946	21.7
		Recommended Limits	50.73-56.07	0.94-1.04	20-24
1900	Head	Measured, 2009.01.10	41.4	1.43	21.7
		Recommended Limits	38.1-42.11	1.4-1.54	20-24
1900	Body	Measured, 2009.01.11	51.1	1.57	21.7
		Recommended Limits	48.83-53.97	1.48-1.64	20-24
2450	Body	Measured, 2009.01.11	51.2	2.03	21.7
		Recommended Limits	48.36-53.45	1.88-2.08	20-24

Table 2. Dielectric Parameters of Tissue Simulant Fluid

The composition of the brain tissue simulating liquid for 850 & 1900 & 2450 band:

Ingredient	850MHz (Head)	850MHz (Body)	1900MHz (Head)	1900MHz (Body)	2450Mhz (Body)
DGMBE	X	X	444.52 g	300.67g	301.7 ml
Water	532.98 g	631.68 g	552.42 g	716.56 g	698.3 ml
Salt	18.3 g	11.72 g	3.06 g	4.0 g	X
Preventol D-7	2.4 g	1.2 g	X	X	X
Cellulose	3.2 g	X	X	X	X
Sugar	766.0 g	600 g	X	X	X
Total amount	1 L (1.0kg)	1 L (1.0kg)	1 L (1.0kg)	1 L (1.0kg)	1 L (1.0kg)

Table 3. Recipes for tissue simulating liquid

1.12 Test Standards and Limits

According to FCC 47CFR §2.1093(d) The limits to be used for evaluation are based generally on criteria published by the American National Standards Institute (ANSI) for localized specific absorption rate ("SAR") in Section 4.2 of "IEEE Standard for Safety Levels with Respect to Human Exposure to Radio Frequency Electromagnetic Fields, 3 kHz to 300 GHz," ANSI/IEEE C95.1-1992, Copyright 1992 by the Institute of Electrical and Electronics Engineers, Inc., New York, New York 10017. These criteria for SAR evaluation are similar to those recommended by the National Council on Radiation Protection and Measurements (NCRP) in "Biological Effects and Exposure Criteria for Radio frequency Electromagnetic Fields," NCRP Report No. 86, Section 17.4.5. Copyright NCRP, 1986, Bethesda, Maryland 20814. SAR is a measure of the rate of energy absorption due to exposure to an RF transmitting source. SAR values have been related to threshold levels for potential biological hazards. The criteria to be used are specified in paragraphs (d)(1) and (d)(2) of this section and shall apply for portable devices transmitting in the frequency range from 100 kHz to 6 GHz. Portable devices that transmit at frequencies above 6 GHz are to be evaluated in terms of the MPE limits specified in § 1.1310 of this chapter.

Measurements and calculations to demonstrate compliance with MPE field strength or power density limits for devices operating above 6 GHz should be made at a minimum distance of 5 cm from the radiating source.

(1) Limits for Occupational/Controlled exposure: 0.4 W/kg as averaged over the whole-body and spatial peak SAR not exceeding 8 W/kg as averaged over any 1 gram of tissue (defined as a tissue volume in the shape of a cube). Exceptions are the hands, wrists, feet and ankles where the spatial peak SAR shall not exceed 20 W/kg, as averaged over an 10 grams of tissue (defined as a tissue volume in the shape of a cube). Occupational/Controlled limits apply when persons are exposed as a consequence of their employment provided these persons are fully aware of and exercise control over their exposure. Awareness of exposure can be accomplished by use of warning labels or by specific training or education through appropriate means, such as an RF safety program in a work environment.

(2) Limits for General Population/Uncontrolled exposure: 0.08 W/kg as averaged over the whole-body and spatial peak SAR not exceeding 1.6 W/kg as averaged over any 1 gram of tissue (defined as a tissue volume in the shape of a cube). Exceptions are the hands, wrists, feet and ankles where the spatial peak SAR shall not exceed 4 W/kg, as averaged over any 10 grams of tissue (defined as a tissue volume in the shape of a cube).

General Population/Uncontrolled limits apply when the general public may be exposed, or when persons that are exposed as a consequence of their employment may not be fully aware of the potential for exposure or do not exercise control over their exposure.

Warning labels placed on consumer devices such as cellular telephones will not be sufficient reason to allow these devices to be evaluated subject to limits for occupational/controlled exposure in paragraph (d)(1) of this section.(Table .6)

Human Exposure	Uncontrolled Environment General Population	Controlled Environment Occupational
Spatial Peak SAR (Brain)	1.60 m W/g	8.00 m W/g
Spatial Average SAR (Whole Body)	0.08 m W/g	0.40 m W/g
Spatial Peak SAR (Hands/Feet/Ankle/Wrist)	4.00 m W/g	20.00 m W/g

Table 4. RF exposure limits

Notes:

1. Uncontrolled environments are defined as locations where there is potential exposure of individuals who have no knowledge or control of their potential exposure.
2. Controlled environments are defined as locations where there is potential exposure of individuals who have knowledge of their potential exposure and can exercise control over their exposure.

2. Summary of Results

Original solution measurement result

GSM 850 MHZ

Right Head (Cheek Position)						
Frequency	Channel	MHz	Conducted Output Power (Average)	Measured(W/kg) 1g	Amb. Temp[°C]	Liquid Temp[°C]
850 MHz	128	824.2	32.8dbm	0.250	22.1	21.7
	190	836.6	33.3dbm	0.276	22.1	21.7
	251	848.8	33.7dbm	0.362	22.1	21.7
Left Head (Cheek Position)						
Frequency	Channel	MHz	Conducted Output Power (Average)	Measured(W/kg) 1g	Amb. Temp[°C]	Liquid Temp[°C]
850 MHz	128	824.2	32.8dbm	0.221	22.1	21.7
	190	836.6	33.3dbm	0.239	22.1	21.7
	251	848.8	33.7dbm	0.315	22.1	21.7
Right Head (15° Tilt Position)						
Frequency	Channel	MHz	Conducted Output Power (Average)	Measured(W/kg) 1g	Amb. Temp[°C]	Liquid Temp[°C]
850 MHz	128	824.2	32.8dbm	0.160	22.1	21.7
	190	836.6	33.3dbm	0.175	22.1	21.7
	251	848.8	33.7dbm	0.225	22.1	21.7
Left Head (15° Tilt Position)						
Frequency	Channel	MHz	Conducted Output Power (Average)	Measured(W/kg) 1g	Amb. Temp[°C]	Liquid Temp[°C]
850 MHz	128	824.2	32.8dbm	0.147	22.1	21.7
	190	836.6	33.3dbm	0.161	22.1	21.7
	251	848.8	33.7dbm	0.207	22.1	21.7
Body worn (testing in GPRS mode)						
Frequency	Channel	MHz	Conducted Output Power (Average)	Measured(W/kg) 1g	Amb. Temp[°C]	Liquid Temp[°C]

850 MHz	128	824.2	32.8dbm	0.467	22.1	21.7
	190	836.6	33.3dbm	0.576	22.1	21.7
	251	848.8	33.7dbm	0.8	22.1	21.7

PCS 1900 MHZ

Right Head (Cheek Position)						
Frequency	Channel	MHz	Conducted Output Power (Average)	Measured(W/kg) 1g	Amb. Temp[°C]	Liquid Temp[°C]
1900 MHz	512	1850.2	30.8dbm	0.629	22.1	21.7
	661	1880	30.8dbm	0.646	22.1	21.7
	810	1909.8	30.7dbm	0.666	22.1	21.7
Left Head (Cheek Position)						
Frequency	Channel	MHz	Conducted Output Power (Average)	Measured(W/kg) 1g	Amb. Temp[°C]	Liquid Temp[°C]
1900 MHz	512	1850.2	30.8dbm	0.643	22.1	21.7
	661	1880	30.8dbm	0.654	22.1	21.7
	810	1909.8	30.7dbm	0.675	22.1	21.7
Right Head (15° Tilt Position)						
Frequency	Channel	MHz	Conducted Output Power (Average)	Measured(W/kg) 1g	Amb. Temp[°C]	Liquid Temp[°C]
1900 MHz	512	1850.2	30.8dbm	0.307	22.1	21.7
	661	1880	30.8dbm	0.323	22.1	21.7
	810	1909.8	30.7dbm	0.358	22.1	21.7
Left Head (15° Tilt Position)						
Frequency	Channel	MHz	Conducted Output Power (Average)	Measured(W/kg) 1g	Amb. Temp[°C]	Liquid Temp[°C]
1900 MHz	512	1850.2	30.8dbm	0.357	22.1	21.7
	661	1880	30.8dbm	0.367	22.1	21.7
	810	1909.8	30.7dbm	0.379	22.1	21.7
Left Head (Cheek Position)_repeated with Memory card						
Frequency	Channel	MHz	Conducted Output Power (Average)	Measured(W/kg) 1g	Amb. Temp[°C]	Liquid Temp[°C]

1900 MHz	810	1909.8	30.7dbm	0.674	22.1	21.7
Left Head (Cheek Position)_repeated with Bluetooth active						
Frequency	Channel	MHz	Conducted Output Power (Average)	Measured(W/kg) 1g	Amb. Temp[°C]	Liquid Temp[°C]
1900 MHz	810	1909.8	30.7dbm	0.660	22.1	21.7
Left Head (Cheek Position)_repeated with WLAN802.11 b active						
Frequency	Channel	MHz	Conducted Output Power (Average)	Measured(W/kg) 1g	Amb. Temp[°C]	Liquid Temp[°C]
1900 MHz	810	1909.8	30.7dbm	0.640	22.1	21.7
Left Head (Cheek Position)_repeated with WLAN802.11 g active						
Frequency	Channel	MHz	Conducted Output Power (Average)	Measured(W/kg) 1g	Amb. Temp[°C]	Liquid Temp[°C]
1900 MHz	810	1909.8	30.7dbm	0.622	22.1	21.7
Left Head (Cheek Position)_repeated with Bluetooth & WLAN802.11 b active						
Frequency	Channel	MHz	Conducted Output Power (Average)	Measured(W/kg) 1g	Amb. Temp[°C]	Liquid Temp[°C]
1900 MHz	810	1909.8	30.7dbm	0.630	22.1	21.7
Left Head (Cheek Position)_repeated with WELLDONE Battery						
Frequency	Channel	MHz	Conducted Output Power (Average)	Measured(W/kg) 1g	Amb. Temp[°C]	Liquid Temp[°C]
1900 MHz	810	1909.8	30.7dbm	0.665	22.1	21.7
Body worn (testing in GPRS mode)						
Frequency	Channel	MHz	Conducted Output Power (Average)	Measured(W/kg) 1g	Amb. Temp[°C]	Liquid Temp[°C]
1900 MHz	512	1850.2	30.8dbm	0.934	22.1	21.7
	661	1880	30.8dbm	0.830	22.1	21.7
	810	1909.8	30.7dbm	0.825	22.1	21.7
Body worn (testing in GPRS mode)_repeated for EUT front to phantom						
Frequency	Channel	MHz	Conducted Output Power (Average)	Measured(W/kg) 1g	Amb. Temp[°C]	Liquid Temp[°C]
1900 MHz	512	1850.2	30.8dbm	0.471	22.1	21.7

Body worn (testing in GPRS mode)_repeated with Memory card						
Frequency	Channel	MHz	Conducted Output Power (Average)	Measured(W/kg) 1g	Amb. Temp[°C]	Liquid Temp[°C]
1900 MHz	512	1850.2	30.8dbm	0.863	22.1	21.7
Body worn (testing in GPRS mode)_repeated with Bluetooth active						
Frequency	Channel	MHz	Conducted Output Power (Average)	Measured(W/kg) 1g	Amb. Temp[°C]	Liquid Temp[°C]
1900 MHz	512	1850.2	30.8dbm	0.841	22.1	21.7
Body worn (testing in GPRS mode)_repeated with WLAN802.11 b active						
Frequency	Channel	MHz	Conducted Output Power (Average)	Measured(W/kg) 1g	Amb. Temp[°C]	Liquid Temp[°C]
1900 MHz	512	1850.2	30.8dbm	0.968	22.1	21.7
Body worn (testing in GPRS mode)_repeated with WLAN802.11 g active						
Frequency	Channel	MHz	Conducted Output Power (Average)	Measured(W/kg) 1g	Amb. Temp[°C]	Liquid Temp[°C]
1900 MHz	512	1850.2	30.8dbm	0.925	22.1	21.7
Body worn (testing in GPRS mode)_repeated with Bluetooth & WLAN802.11 b active						
Frequency	Channel	MHz	Conducted Output Power (Average)	Measured(W/kg) 1g	Amb. Temp[°C]	Liquid Temp[°C]
1900 MHz	512	1850.2	30.8dbm	0.906	22.1	21.7
Body worn (testing in GPRS mode)_repeated with WELLDONE Battery						
Frequency	Channel	MHz	Conducted Output Power (Average)	Measured(W/kg) 1g	Amb. Temp[°C]	Liquid Temp[°C]
1900 MHz	512	1850.2	30.8dbm	0.908	22.1	21.7

WLAN802.11 b

Body worn						
Frequency	Channel	MHz	Conducted Output Power (Average)	Measured(W/kg) 1g	Amb. Temp[°C]	Liquid Temp[°C]
WLAN 802.11 b	1	2412	17.35dbm	0.186	22.1	21.7
	6	2437	17.2dbm	0.225	22.1	21.7
	11	2462	17.4dbm	0.236	22.1	21.7

Body worn- repeated for EUT front to phantom						
Frequency	Channel	MHz	Conducted Output Power (Average)	Measured(W/kg) 1g	Amb. Temp[°C]	Liquid Temp[°C]
WLAN 802.11 b	11	2462	17.4dbm	0.059	22.1	21.7
Body worn-repeated with Memory card						
Frequency	Channel	MHz	Conducted Output Power (Average)	Measured(W/kg) 1g	Amb. Temp[°C]	Liquid Temp[°C]
WLAN 802.11 b	11	2462	17.4dbm	0.256	22.1	21.7
Body worn-repeated with Bluetooth active						
Frequency	Channel	MHz	Conducted Output Power (Average)	Measured(W/kg) 1g	Amb. Temp[°C]	Liquid Temp[°C]
WLAN 802.11 b	11	2462	17.4dbm	0.256	22.1	21.7
Body worn- repeated with WELLDONE Battery						
Frequency	Channel	MHz	Conducted Output Power (Average)	Measured(W/kg) 1g	Amb. Temp[°C]	Liquid Temp[°C]
WLAN 802.11 b	11	2462	17.4dbm	0.295	22.1	21.7

WLAN 802.11 g

Body worn						
Frequency	Channel	MHz	Conducted Output Power (Average)	Measured(W/kg) 1g	Amb. Temp[°C]	Liquid Temp[°C]
WLAN 802.11 g	1	2412	17.23dbm	0.043	22.1	21.7
	6	2437	17.1dbm	0.051	22.1	21.7
	11	2462	17.2dbm	0.053	22.1	21.7

Second solution measurement result (change Camera &

LCM)

GSM 850 MHZ

Right Head (Cheek Position)						
Frequency	Channel	MHz	Conducted Output Power (Average)	Measured(W/kg) 1g	Amb. Temp[°C]	Liquid Temp[°C]
850 MHz	251	848.8	33.5dbm	0.426	22.1	21.7
Body worn (testing in GPRS mode)						
Frequency	Channel	MHz	Conducted Output Power (Average)	Measured(W/kg) 1g	Amb. Temp[°C]	Liquid Temp[°C]
850 MHz	251	848.8	33.5dbm	0.754	22.1	21.7

PCS 1900 MHZ

Left Head (Cheek Position)						
Frequency	Channel	MHz	Conducted Output Power (Average)	Measured(W/kg) 1g	Amb. Temp[°C]	Liquid Temp[°C]
1900 MHz	810	1909.8	30.6dbm	0.783	22.1	21.7
Body worn (testing in GPRS mode)_repeated with WLAN802.11 b active						
Frequency	Channel	MHz	Conducted Output Power (Average)	Measured(W/kg) 1g	Amb. Temp[°C]	Liquid Temp[°C]
1900 MHz	512	1850.2	30.6dbm	0.973	22.1	21.7

WLAN802.11 b

Body worn- repeated with WELLDONE Battery						
Frequency	Channel	MHz	Conducted Output Power (Average)	Measured(W/kg) 1g	Amb. Temp[°C]	Liquid Temp[°C]
WLAN 802.11 b	11	2462	17.46dbm	0.262	22.1	21.7

WLAN 802.11 g

Body worn						
Frequency	Channel	MHz	Conducted Output Power (Average)	Measured(W/kg) 1g	Amb. Temp[°C]	Liquid Temp[°C]
WLAN 802.11 g	11	2462	17.3dbm	0.045	22.1	21.7

Third solution measurement result (change Metal button)

GSM 850 MHZ

Right Head (Cheek Position)						
Frequency	Channel	MHz	Conducted Output Power (Average)	Measured(W/kg) 1g	Amb. Temp[°C]	Liquid Temp[°C]
850 MHz	251	848.8	33.7dbm	0.377	22.1	21.7
Body worn (testing in GPRS mode)						
Frequency	Channel	MHz	Conducted Output Power (Average)	Measured(W/kg) 1g	Amb. Temp[°C]	Liquid Temp[°C]
850 MHz	251	848.8	33.7dbm	0.797	22.1	21.7

PCS 1900 MHZ

Left Head (Cheek Position)						
Frequency	Channel	MHz	Conducted Output Power (Average)	Measured(W/kg) 1g	Amb. Temp[°C]	Liquid Temp[°C]
1900 MHz	810	1909.8	30.7dbm	0.73	22.1	21.7
Body worn (testing in GPRS mode)_repeated with WLAN802.11 b active						
Frequency	Channel	MHz	Conducted Output Power (Average)	Measured(W/kg) 1g	Amb. Temp[°C]	Liquid Temp[°C]
1900 MHz	512	1850.2	30.6dbm	0.928	22.1	21.7

WLAN802.11 b

Body worn- repeated with WELLDONE Battery						
Frequency	Channel	MHz	Conducted Output Power (Average)	Measured(W/kg) 1g	Amb. Temp[°C]	Liquid Temp[°C]
WLAN 802.11 b	11	2462	17.4dbm	0.306	22.1	21.7

WLAN 802.11 g

Body worn						
Frequency	Channel	MHz	Conducted Output Power (Average)	Measured(W/kg) 1g	Amb. Temp[°C]	Liquid Temp[°C]
WLAN 802.11 g	11	2462	17.32bm	0.055	22.1	21.7

Fourth solution measurement result (2nd solution change Metal button)

GSM 850 MHZ

Right Head (Cheek Position)						
Frequency	Channel	MHz	Conducted Output Power (Average)	Measured(W/kg) 1g	Amb. Temp[°C]	Liquid Temp[°C]
850 MHz	251	848.8	33.5dbm	0.409	22.1	21.7
Body worn (testing in GPRS mode)						
Frequency	Channel	MHz	Conducted Output Power (Average)	Measured(W/kg) 1g	Amb. Temp[°C]	Liquid Temp[°C]
850 MHz	251	848.8	33.5dbm	0.856	22.1	21.7

PCS 1900 MHZ

Left Head (Cheek Position)						
Frequency	Channel	MHz	Conducted Output Power (Average)	Measured(W/kg) 1g	Amb. Temp[°C]	Liquid Temp[°C]
1900 MHz	810	1909.8	30.6dbm	0.749	22.1	21.7

Body worn (testing in GPRS mode)_repeated with WLAN802.11 b active						
Frequency	Channel	MHz	Conducted Output Power (Average)	Measured(W/kg) 1g	Amb. Temp[°C]	Liquid Temp[°C]
1900 MHz	512	1850.2	30.6dbm	0.953	22.1	21.7

WLAN802.11 b

Body worn- repeated with WELLDONE Battery						
Frequency	Channel	MHz	Conducted Output Power (Average)	Measured(W/kg) 1g	Amb. Temp[°C]	Liquid Temp[°C]
WLAN 802.11 b	11	2462	17.46dbm	0.3	22.1	21.7

WLAN 802.11 g

Body worn						
Frequency	Channel	MHz	Conducted Output Power (Average)	Measured(W/kg) 1g	Amb. Temp[°C]	Liquid Temp[°C]
WLAN 802.11 g	11	2462	17.3dbm	0.055	22.1	21.7

3. Instruments List

Manufacturer	Device	Type	Serial number	Date of last calibration
Schmid & Partner Engineering AG	Dosimetric E-FieldProbe	EX3DV3	3526	Aug.26.2008
Schmid & Partner Engineering AG	850/1900/2450MHz System Validation Dipole	D835V2 D1900V2 D2450V2	4d063 5d027 727	Jun.06.2008 Apr.15.2008 Apr.11.2008
Schmid & Partner Engineering AG	Data acquisition Electronics	DAE4	547	Jan.24.2008
Schmid & Partner Engineering AG	Software	DASY 4 V4.7 Build71	N/A	Calibration not required
Schmid & Partner Engineering AG	Phantom	SAM	N/A	Calibration not required
Agilent	Network Analyzer	8753D	3410A56662	Apr.16.2008
Agilent	Dielectric Probe Kit	85070D	US01440168	Calibration not required
Agilent	Dual-directional coupler	778D	50313	Aug.26.2008
		777D	50014	Aug.26.2008
Agilent	RF Signal Generator	E4438c	MY45093613	May.21.2008
Agilent	Power Sensor	8481H	MY41091361	May.20.2008
R&S	Radio Communication Test	CMU200	109326	Mar.11.2008

4. Measurements

Date/Time: 2008/11/25 02:31:53

Re Cheek_CH128

DUT: SAPP100;

Communication System: GSM 850; Frequency: 824.2 MHz; Duty Cycle: 1:8.3

Medium: Head 850 MHz Medium parameters used (interpolated): $f = 824.2$ MHz; $\sigma = 0.898$ mho/m; $\epsilon_r = 42.3$; $\rho = 1000$ kg/m³

Phantom section: Right Section

- Probe: EX3DV3 - SN3526; ConvF(10.93, 10.93,10.93); Calibrated: 2008/8/26
- Sensor-Surface: 4mm (Mechanical Surface Detection)
- Electronics: DAE4 Sn547; Calibrated: 2008/1/24
- Phantom: SAM1; Type: SAM 4.0; Serial: TP:1419
- Measurement SW: DASY4, V4.7 Build 71; Postprocessing SW: SEMCAD, V1.8 Build 184

RE Cheek/Area Scan (61x91x1): Measurement grid: dx=15mm, dy=15mm

Maximum value of SAR (interpolated) = 0.267 mW/g

RE Cheek/Zoom Scan (5x5x7)/Cube 0: Measurement grid: dx=8mm, dy=8mm, dz=5mm

Reference Value = 6.16 V/m; Power Drift = -0.192 dB

Peak SAR (extrapolated) = 0.309 W/kg

SAR(1 g) = 0.250 mW/g; SAR(10 g) = 0.188 mW/g

Maximum value of SAR (measured) = 0.264 mW/g

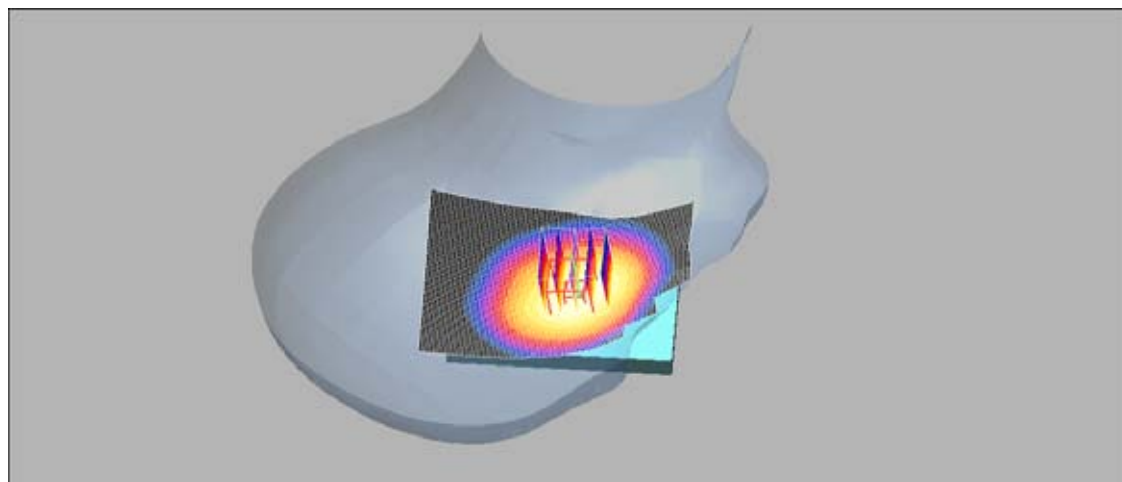
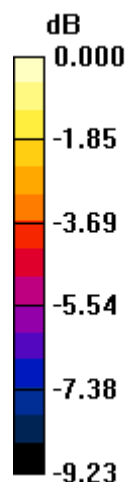

0 dB = 0.264mW/g

Date/Time: 2008/11/25 02:55:53

Re Cheek_CH190

DUT: SAPP100;

Communication System: GSM 850; Frequency: 836.6 MHz; Duty Cycle: 1:8.3

Medium: Head 850 MHz Medium parameters used: $f = 837$ MHz; $\sigma = 0.911$ mho/m; $\epsilon_r = 42.1$;
 $\rho = 1000$ kg/m³

Phantom section: Right Section

DASY4 Configuration:

- Probe: EX3DV3 - SN3526; ConvF(10.93, 10.93,10.93); Calibrated: 2008/8/26
- Sensor-Surface: 4mm (Mechanical Surface Detection)
- Electronics: DAE4 Sn547; Calibrated: 2008/1/24
- Phantom: SAM1; Type: SAM 4.0; Serial: TP:1419
- Measurement SW: DASY4, V4.7 Build 71; Postprocessing SW: SEMCAD, V1.8 Build 184

RE Cheek/Area Scan (61x91x1): Measurement grid: dx=15mm, dy=15mm

Maximum value of SAR (interpolated) = 0.291 mW/g

RE Cheek/Zoom Scan (5x5x7)/Cube 0: Measurement grid: dx=8mm, dy=8mm,
dz=5mm

Reference Value = 6.22 V/m; Power Drift = -0.039 dB

Peak SAR (extrapolated) = 0.341 W/kg

SAR(1 g) = 0.276 mW/g; SAR(10 g) = 0.207 mW/g

Maximum value of SAR (measured) = 0.292 mW/g

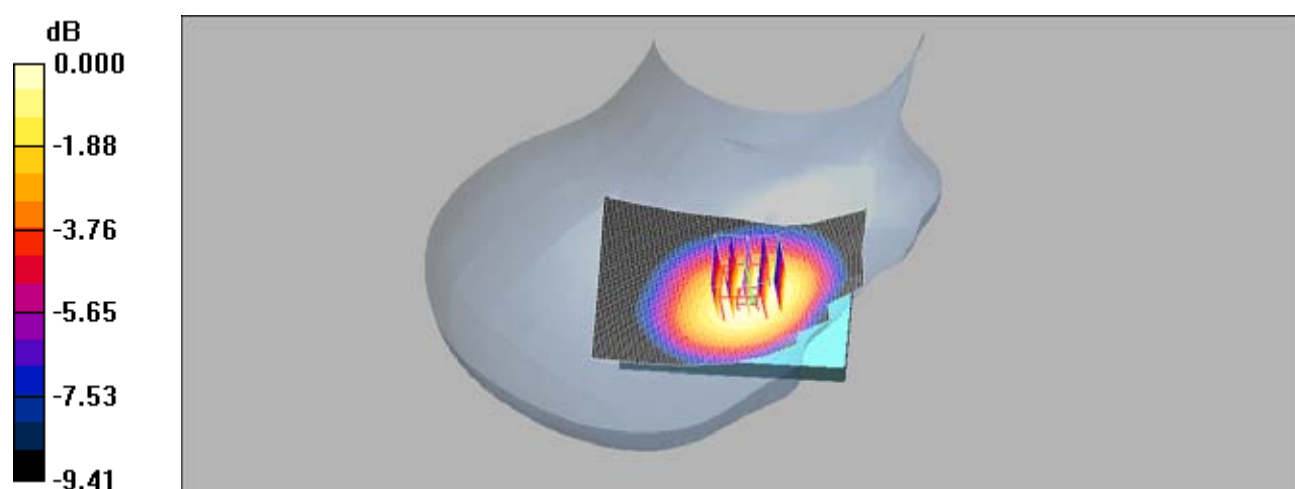

0 dB = 0.292mW/g

Date/Time: 2008/11/25 03:18:01

Re Cheek_CH251

DUT: SAPP100;

Communication System: GSM 850; Frequency: 848.8 MHz; Duty Cycle: 1:8.3

Medium: Head 850 MHz Medium parameters used: $f = 849$ MHz; $\sigma = 0.919$ mho/m; $\epsilon_r = 41.9$;
 $\rho = 1000$ kg/m³

Phantom section: Right Section

DASY4 Configuration:

- Probe: EX3DV3 - SN3526; ConvF(10.93, 10.93,10.93); Calibrated: 2008/8/26
- Sensor-Surface: 4mm (Mechanical Surface Detection)
- Electronics: DAE4 Sn547; Calibrated: 2008/1/24
- Phantom: SAM1; Type: SAM 4.0; Serial: TP:1419
- Measurement SW: DASY4, V4.7 Build 71; Postprocessing SW: SEMCAD, V1.8 Build 184

RE Cheek/Area Scan (61x91x1): Measurement grid: dx=15mm, dy=15mm

Maximum value of SAR (interpolated) = 0.384 mW/g

RE Cheek/Zoom Scan (5x5x7)/Cube 0: Measurement grid: dx=8mm, dy=8mm,
dz=5mm

Reference Value = 7.09 V/m; Power Drift = 0.005 dB

Peak SAR (extrapolated) = 0.449 W/kg

SAR(1 g) = 0.362 mW/g; SAR(10 g) = 0.270 mW/g

Maximum value of SAR (measured) = 0.384 mW/g

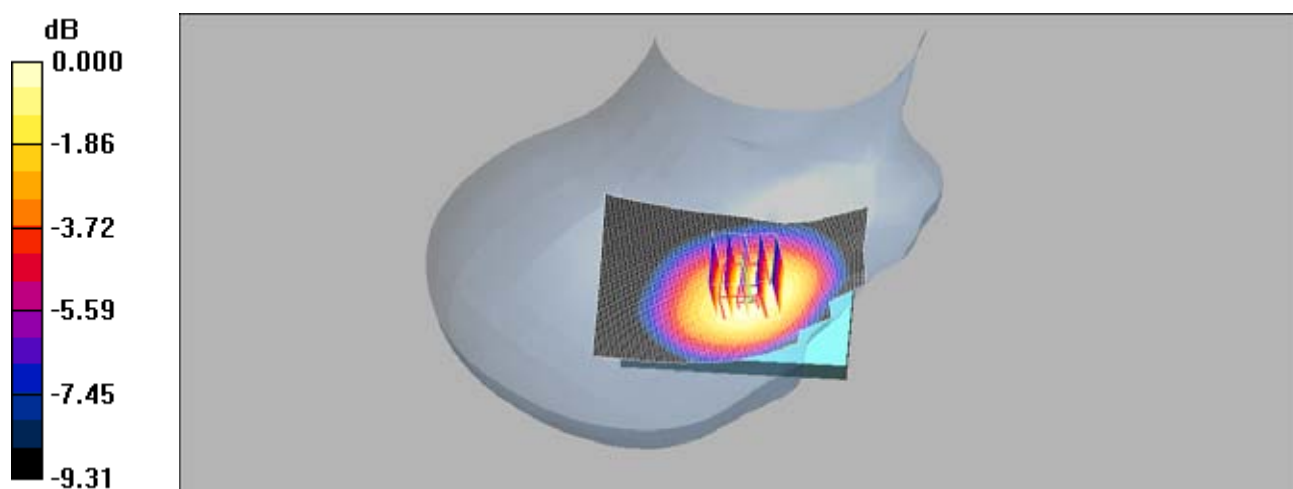

0 dB = 0.384mW/g

Date/Time: 2008/11/25 05:06:36

Le Cheek_CH128

DUT: SAPP100;

Communication System: GSM 850; Frequency: 824.2 MHz; Duty Cycle: 1:8.3

Medium: Head 850 MHz Medium parameters used (interpolated): $f = 824.2$ MHz; $\sigma = 0.898$ mho/m; $\epsilon_r = 42.3$; $\rho = 1000$ kg/m³

Phantom section: Left Section

DASY4 Configuration:

- Probe: EX3DV3 - SN3526; ConvF(10.93, 10.93,10.93); Calibrated: 2008/8/26
- Sensor-Surface: 4mm (Mechanical Surface Detection)
- Electronics: DAE4 Sn547; Calibrated: 2008/1/24
- Phantom: SAM1; Type: SAM 4.0; Serial: TP:1419
- Measurement SW: DASY4, V4.7 Build 71; Postprocessing SW: SEMCAD, V1.8 Build 184

LE Cheek/Area Scan (61x91x1): Measurement grid: dx=15mm, dy=15mm

Maximum value of SAR (interpolated) = 0.233 mW/g

LE Cheek/Zoom Scan (5x5x7)/Cube 0: Measurement grid: dx=8mm, dy=8mm, dz=5mm

Reference Value = 5.67 V/m; Power Drift = -0.019 dB

Peak SAR (extrapolated) = 0.273 W/kg

SAR(1 g) = 0.221 mW/g; SAR(10 g) = 0.164 mW/g

Maximum value of SAR (measured) = 0.234 mW/g

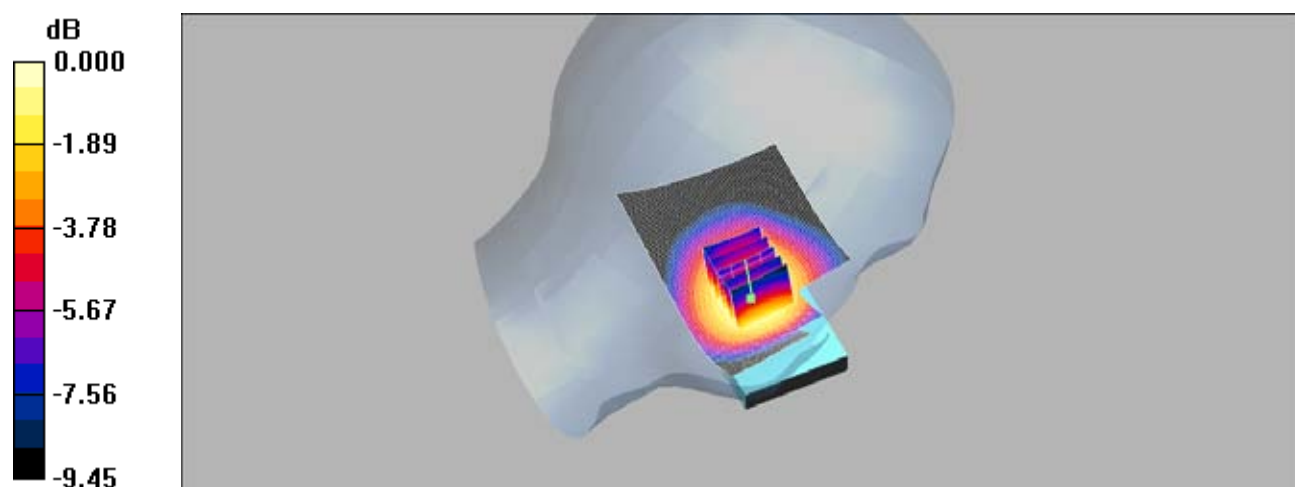

Date/Time: 2008/11/25 05:29:26

Le Cheek_CH190

DUT: SAPP100;

Communication System: GSM 850; Frequency: 836.6 MHz; Duty Cycle: 1:8.3

Medium: Head 850 MHz Medium parameters used: $f = 837$ MHz; $\sigma = 0.911$ mho/m; $\epsilon_r = 42.1$;
 $\rho = 1000$ kg/m³

Phantom section: Left Section

DASY4 Configuration:

- Probe: EX3DV3 - SN3526; ConvF(10.93, 10.93,10.93); Calibrated: 2008/8/26
- Sensor-Surface: 4mm (Mechanical Surface Detection)
- Electronics: DAE4 Sn547; Calibrated: 2008/1/24
- Phantom: SAM1; Type: SAM 4.0; Serial: TP:1419
- Measurement SW: DASY4, V4.7 Build 71; Postprocessing SW: SEMCAD, V1.8 Build 184

LE Cheek/Area Scan (61x91x1): Measurement grid: dx=15mm, dy=15mm

Maximum value of SAR (interpolated) = 0.252 mW/g

LE Cheek/Zoom Scan (5x5x7)/Cube 0: Measurement grid: dx=8mm, dy=8mm,
dz=5mm

Reference Value = 5.82 V/m; Power Drift = -0.033 dB

Peak SAR (extrapolated) = 0.299 W/kg

SAR(1 g) = 0.239 mW/g; SAR(10 g) = 0.178 mW/g

Maximum value of SAR (measured) = 0.253 mW/g

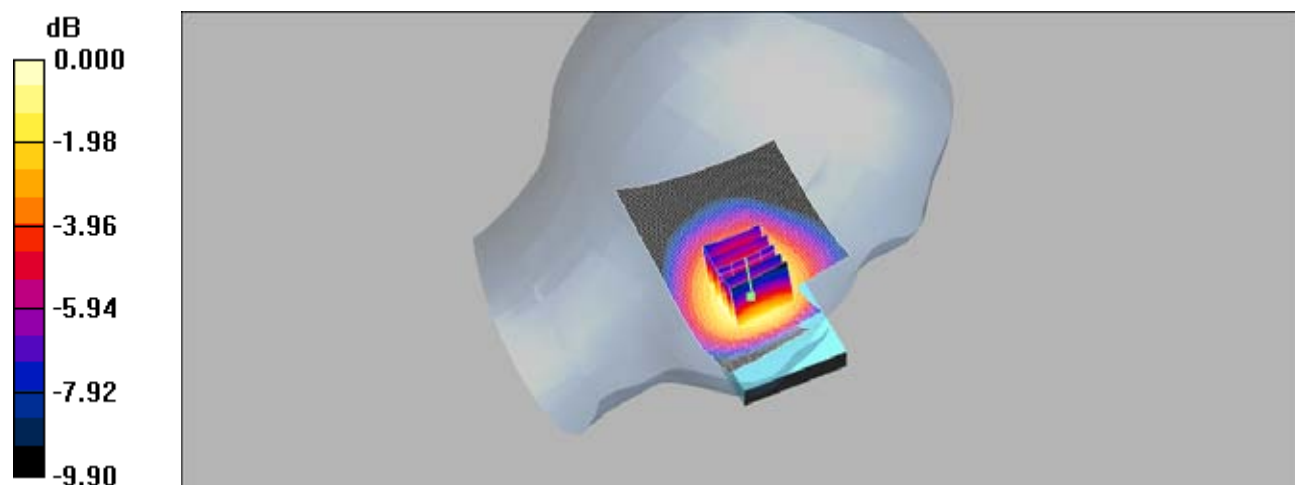

Date/Time: 2008/11/25 05:55:20

Le Cheek_CH251

DUT: SAPP100;

Communication System: GSM 850; Frequency: 848.8 MHz; Duty Cycle: 1:8.3

Medium: Head 850 MHz Medium parameters used: $f = 849$ MHz; $\sigma = 0.919$ mho/m; $\epsilon_r = 41.9$;
 $\rho = 1000$ kg/m³

Phantom section: Left Section

DASY4 Configuration:

- Probe: EX3DV3 - SN3526; ConvF(10.93, 10.93,10.93); Calibrated: 2008/8/26
- Sensor-Surface: 4mm (Mechanical Surface Detection)
- Electronics: DAE4 Sn547; Calibrated: 2008/1/24
- Phantom: SAM1; Type: SAM 4.0; Serial: TP:1419
- Measurement SW: DASY4, V4.7 Build 71; Postprocessing SW: SEMCAD, V1.8 Build 184

LE Cheek/Area Scan (61x91x1): Measurement grid: dx=15mm, dy=15mm

Maximum value of SAR (interpolated) = 0.332 mW/g

LE Cheek/Zoom Scan (5x5x7)/Cube 0: Measurement grid: dx=8mm, dy=8mm,
dz=5mm

Reference Value = 6.63 V/m; Power Drift = 0.018 dB

Peak SAR (extrapolated) = 0.391 W/kg

SAR(1 g) = 0.315 mW/g; SAR(10 g) = 0.234 mW/g

Maximum value of SAR (measured) = 0.333 mW/g

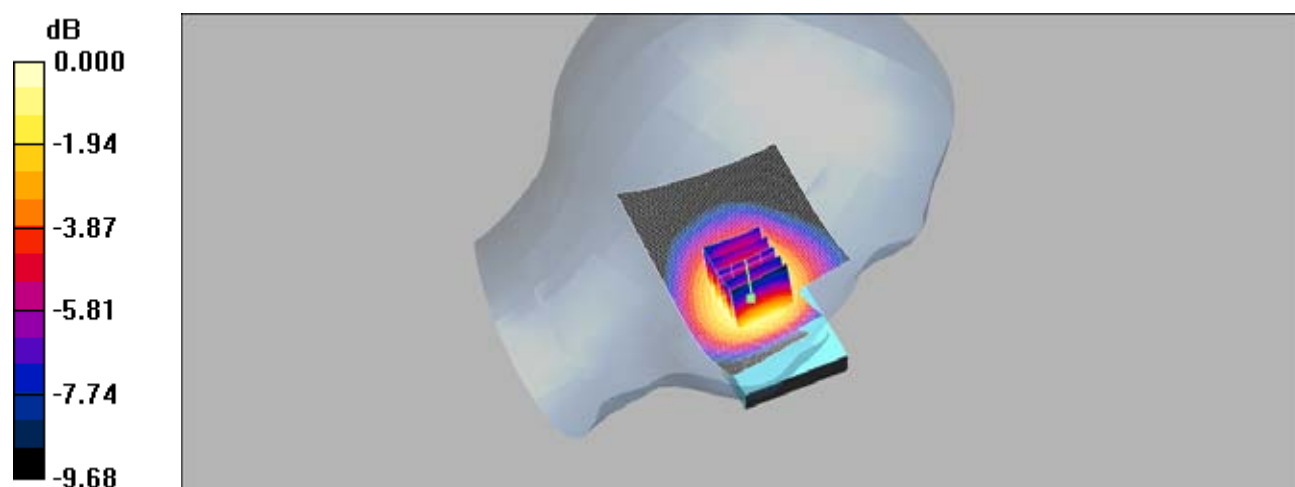

0 dB = 0.333mW/g

Date/Time: 2008/11/25 03:41:46

Re Tilt_CH128

DUT: SAPP100;

Communication System: GSM 850; Frequency: 824.2 MHz; Duty Cycle: 1:8.3

Medium: Head 850 MHz Medium parameters used (interpolated): $f = 824.2$ MHz; $\sigma = 0.898$ mho/m; $\epsilon_r = 42.3$; $\rho = 1000$ kg/m³

Phantom section: Right Section

DASY4 Configuration:

- Probe: EX3DV3 - SN3526; ConvF(10.93, 10.93,10.93); Calibrated: 2008/8/26
- Sensor-Surface: 4mm (Mechanical Surface Detection)
- Electronics: DAE4 Sn547; Calibrated: 2008/1/24
- Phantom: SAM1; Type: SAM 4.0; Serial: TP:1419
- Measurement SW: DASY4, V4.7 Build 71; Postprocessing SW: SEMCAD, V1.8 Build 184

RE Tilt/Area Scan (61x91x1): Measurement grid: dx=15mm, dy=15mm

Maximum value of SAR (interpolated) = 0.166 mW/g

RE Tilt/Zoom Scan (5x5x7)/Cube 0: Measurement grid: dx=8mm, dy=8mm, dz=5mm

Reference Value = 8.96 V/m; Power Drift = 0.013 dB

Peak SAR (extrapolated) = 0.201 W/kg

SAR(1 g) = 0.160 mW/g; SAR(10 g) = 0.121 mW/g

Maximum value of SAR (measured) = 0.167 mW/g

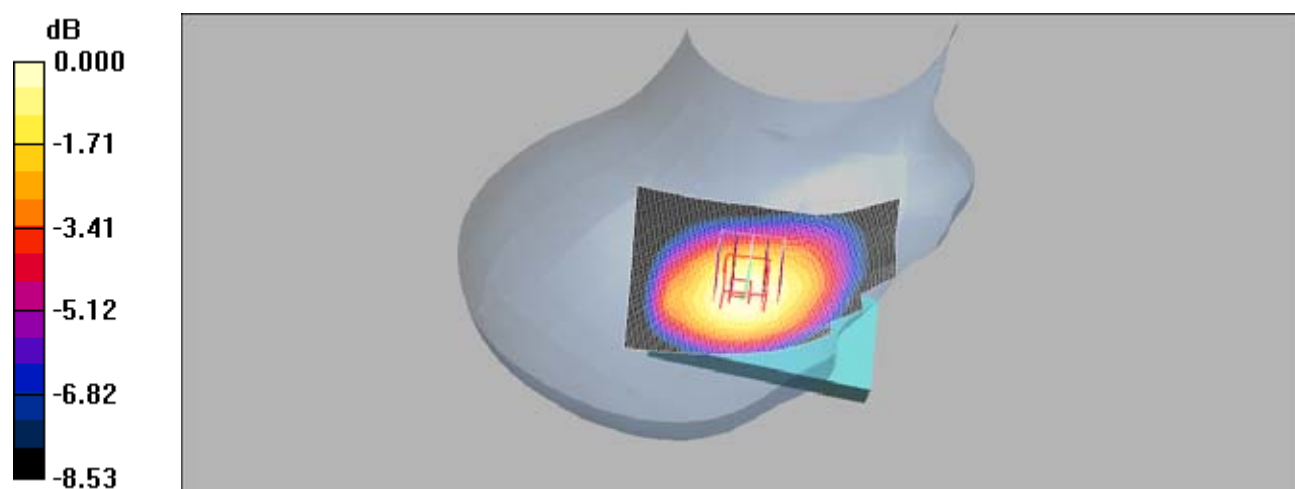

Date/Time: 2008/11/25 04:06:24

Re Tilt_CH190

DUT: SAPP100;

Communication System: GSM 850; Frequency: 836.6 MHz; Duty Cycle: 1:8.3

Medium: Head 850 MHz Medium parameters used: $f = 837$ MHz; $\sigma = 0.911$ mho/m; $\epsilon_r = 42.1$;
 $\rho = 1000$ kg/m³

Phantom section: Right Section

DASY4 Configuration:

- Probe: EX3DV3 - SN3526; ConvF(10.93, 10.93,10.93); Calibrated: 2008/8/26
- Sensor-Surface: 4mm (Mechanical Surface Detection)
- Electronics: DAE4 Sn547; Calibrated: 2008/1/24
- Phantom: SAM1; Type: SAM 4.0; Serial: TP:1419
- Measurement SW: DASY4, V4.7 Build 71; Postprocessing SW: SEMCAD, V1.8 Build 184

RE Tilt/Area Scan (61x91x1): Measurement grid: dx=15mm, dy=15mm

Maximum value of SAR (interpolated) = 0.183 mW/g

RE Tilt/Zoom Scan (5x5x7)/Cube 0: Measurement grid: dx=8mm, dy=8mm, dz=5mm

Reference Value = 9.36 V/m; Power Drift = 0.026 dB

Peak SAR (extrapolated) = 0.221 W/kg

SAR(1 g) = 0.175 mW/g; SAR(10 g) = 0.131 mW/g

Maximum value of SAR (measured) = 0.182 mW/g

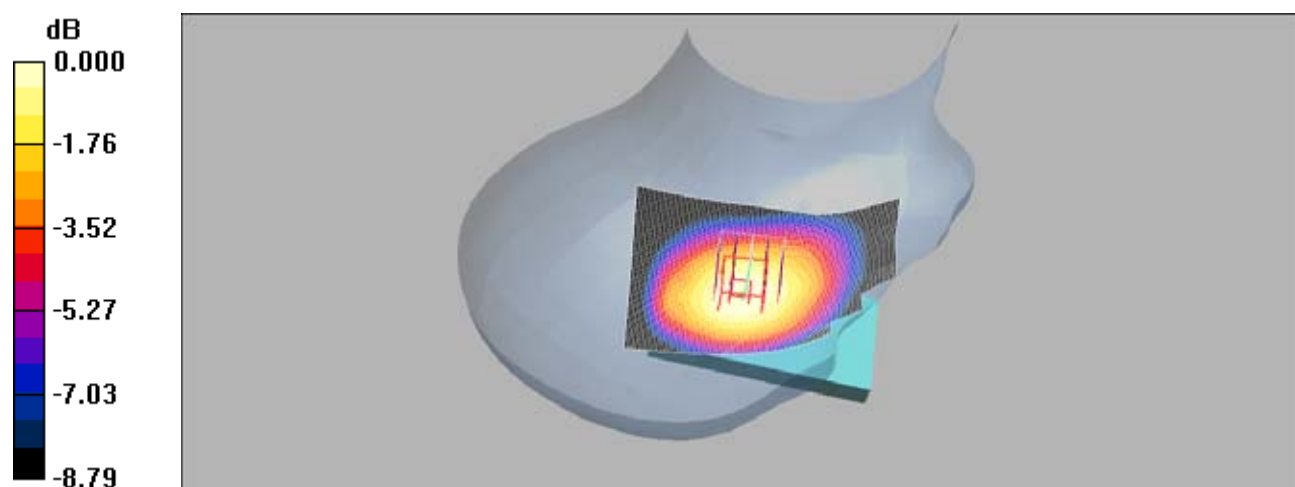

Date/Time: 2008/11/25 04:32:27

Re Tilt_CH251

DUT: SAPP100;

Communication System: GSM 850; Frequency: 848.8 MHz; Duty Cycle: 1:8.3

Medium: Head 850 MHz Medium parameters used: $f = 849$ MHz; $\sigma = 0.919$ mho/m; $\epsilon_r = 42.1$;
 $\rho = 1000$ kg/m³

Phantom section: Right Section

DASY4 Configuration:

- Probe: EX3DV3 - SN3526; ConvF(10.93, 10.93,10.93); Calibrated: 2008/8/26
- Sensor-Surface: 4mm (Mechanical Surface Detection)
- Electronics: DAE4 Sn547; Calibrated: 2008/1/24
- Phantom: SAM1; Type: SAM 4.0; Serial: TP:1419
- Measurement SW: DASY4, V4.7 Build 71; Postprocessing SW: SEMCAD, V1.8 Build 184

RE Tilt/Area Scan (61x91x1): Measurement grid: dx=15mm, dy=15mm

Maximum value of SAR (interpolated) = 0.236 mW/g

RE Tilt/Zoom Scan (5x5x7)/Cube 0: Measurement grid: dx=8mm, dy=8mm, dz=5mm

Reference Value = 10.5 V/m; Power Drift = 0.046 dB

Peak SAR (extrapolated) = 0.284 W/kg

SAR(1 g) = 0.225 mW/g; SAR(10 g) = 0.169 mW/g

Maximum value of SAR (measured) = 0.235 mW/g

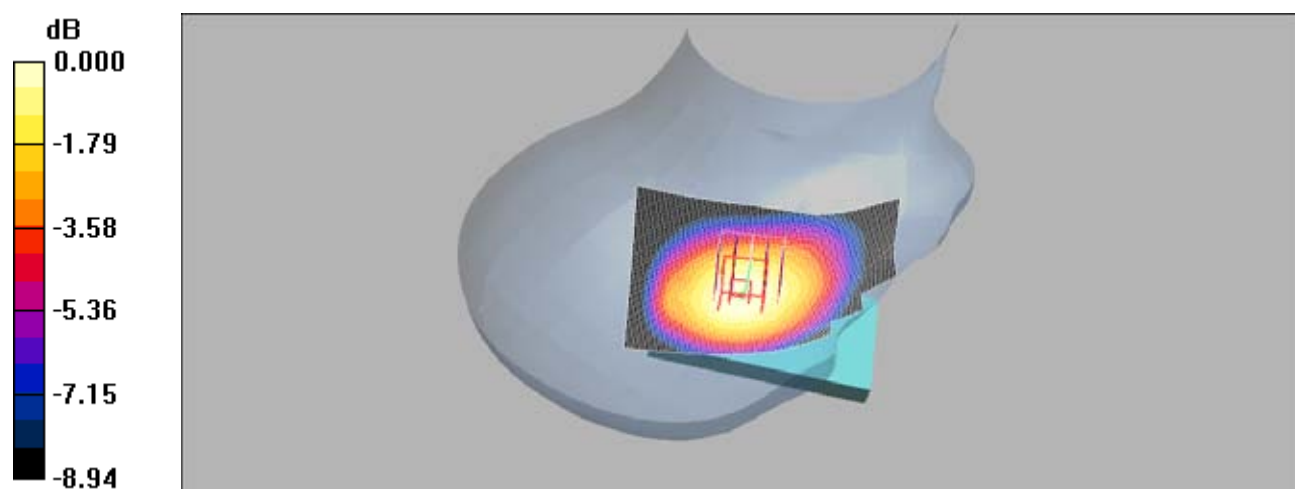

0 dB = 0.235mW/g

Date/Time: 2008/11/25 06:29:58

Le Tilt_CH128

DUT: SAPP100;

Communication System: GSM 850; Frequency: 824.2 MHz; Duty Cycle: 1:8.3

Medium: Head 850 MHz Medium parameters used (interpolated): $f = 824.2$ MHz; $\sigma = 0.898$ mho/m; $\epsilon_r = 42.3$; $\rho = 1000$ kg/m³

Phantom section: Left Section

DASY4 Configuration:

- Probe: EX3DV3 - SN3526; ConvF(10.93, 10.93,10.93); Calibrated: 2008/8/26
- Sensor-Surface: 4mm (Mechanical Surface Detection)
- Electronics: DAE4 Sn547; Calibrated: 2008/1/24
- Phantom: SAM1; Type: SAM 4.0; Serial: TP:1419
- Measurement SW: DASY4, V4.7 Build 71; Postprocessing SW: SEMCAD, V1.8 Build 184

LE Tilt/Area Scan (61x91x1): Measurement grid: dx=15mm, dy=15mm

Maximum value of SAR (interpolated) = 0.154 mW/g

LE Tilt/Zoom Scan (5x5x7)/Cube 0: Measurement grid: dx=8mm, dy=8mm, dz=5mm

Reference Value = 8.84 V/m; Power Drift = 0.020 dB

Peak SAR (extrapolated) = 0.184 W/kg

SAR(1 g) = 0.147 mW/g; SAR(10 g) = 0.111 mW/g

Maximum value of SAR (measured) = 0.154 mW/g

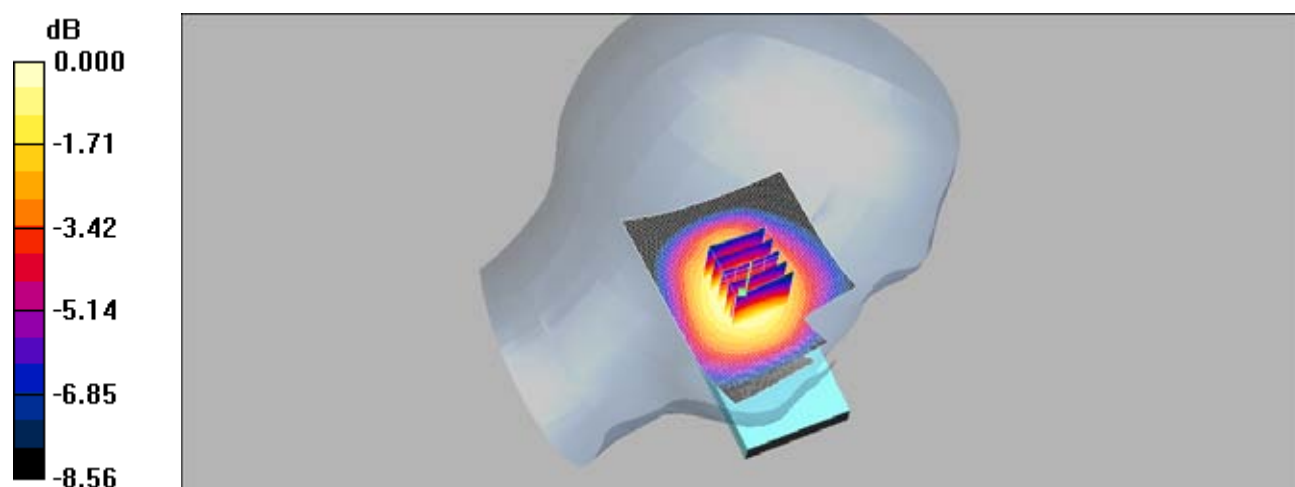

Date/Time: 2008/11/25 06:55:19

Le Tilt_CH190

DUT: SAPP100;

Communication System: GSM 850; Frequency: 836.6 MHz; Duty Cycle: 1:8.3

Medium: Head 850 MHz Medium parameters used: $f = 837$ MHz; $\sigma = 0.911$ mho/m; $\epsilon_r = 42.1$;
 $\rho = 1000$ kg/m³

Phantom section: Left Section

DASY4 Configuration:

- Probe: EX3DV3 - SN3526; ConvF(10.93, 10.93,10.93); Calibrated: 2008/8/26
- Sensor-Surface: 4mm (Mechanical Surface Detection)
- Electronics: DAE4 Sn547; Calibrated: 2008/1/24
- Phantom: SAM1; Type: SAM 4.0; Serial: TP:1419
- Measurement SW: DASY4, V4.7 Build 71; Postprocessing SW: SEMCAD, V1.8 Build 184

LE Tilt/Area Scan (61x91x1): Measurement grid: dx=15mm, dy=15mm

Maximum value of SAR (interpolated) = 0.169 mW/g

LE Tilt/Zoom Scan (5x5x7)/Cube 0: Measurement grid: dx=8mm, dy=8mm,
dz=5mm

Reference Value = 9.14 V/m; Power Drift = 0.020 dB

Peak SAR (extrapolated) = 0.204 W/kg

SAR(1 g) = 0.161 mW/g; SAR(10 g) = 0.121 mW/g

Maximum value of SAR (measured) = 0.168 mW/g

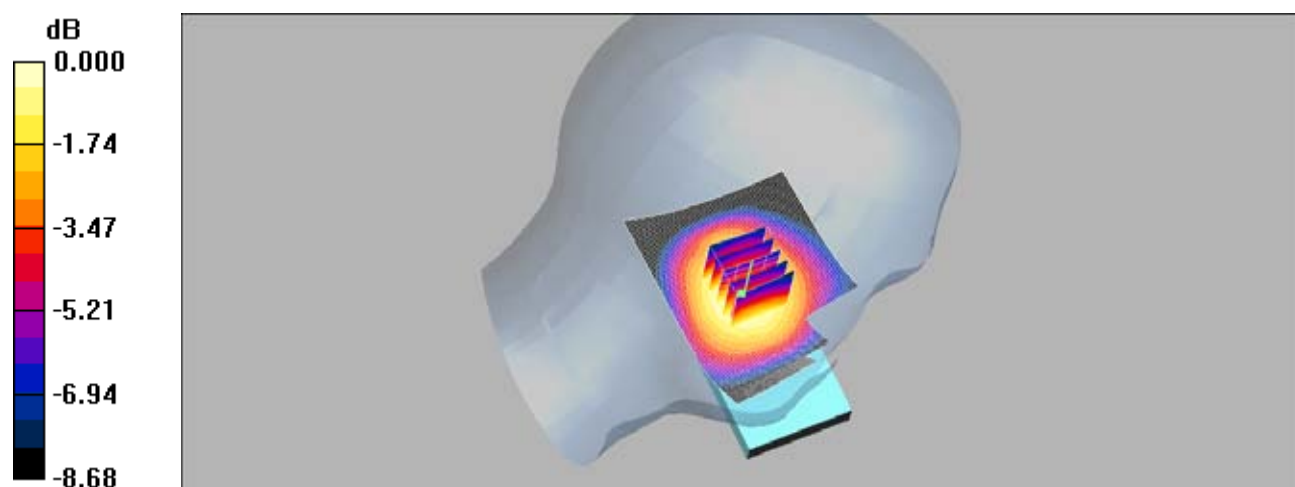

0 dB = 0.168mW/g

Date/Time: 2008/11/25 07:26:37

Le Tilt_CH251

DUT: SAPP100;

Communication System: GSM 850; Frequency: 848.8 MHz; Duty Cycle: 1:8.3

Medium: Head 850 MHz Medium parameters used: $f = 849$ MHz; $\sigma = 0.919$ mho/m; $\epsilon_r = 41.9$;
 $\rho = 1000$ kg/m³

Phantom section: Left Section

DASY4 Configuration:

- Probe: EX3DV3 - SN3526; ConvF(10.93, 10.93,10.93); Calibrated: 2008/8/26
- Sensor-Surface: 4mm (Mechanical Surface Detection)
- Electronics: DAE4 Sn547; Calibrated: 2008/1/24
- Phantom: SAM1; Type: SAM 4.0; Serial: TP:1419
- Measurement SW: DASY4, V4.7 Build 71; Postprocessing SW: SEMCAD, V1.8 Build 184

LE Tilt/Area Scan (61x91x1): Measurement grid: dx=15mm, dy=15mm

Maximum value of SAR (interpolated) = 0.217 mW/g

LE Tilt/Zoom Scan (5x5x7)/Cube 0: Measurement grid: dx=8mm, dy=8mm,
dz=5mm

Reference Value = 10.3 V/m; Power Drift = -0.027 dB

Peak SAR (extrapolated) = 0.262 W/kg

SAR(1 g) = 0.207 mW/g; SAR(10 g) = 0.155 mW/g

Maximum value of SAR (measured) = 0.217 mW/g

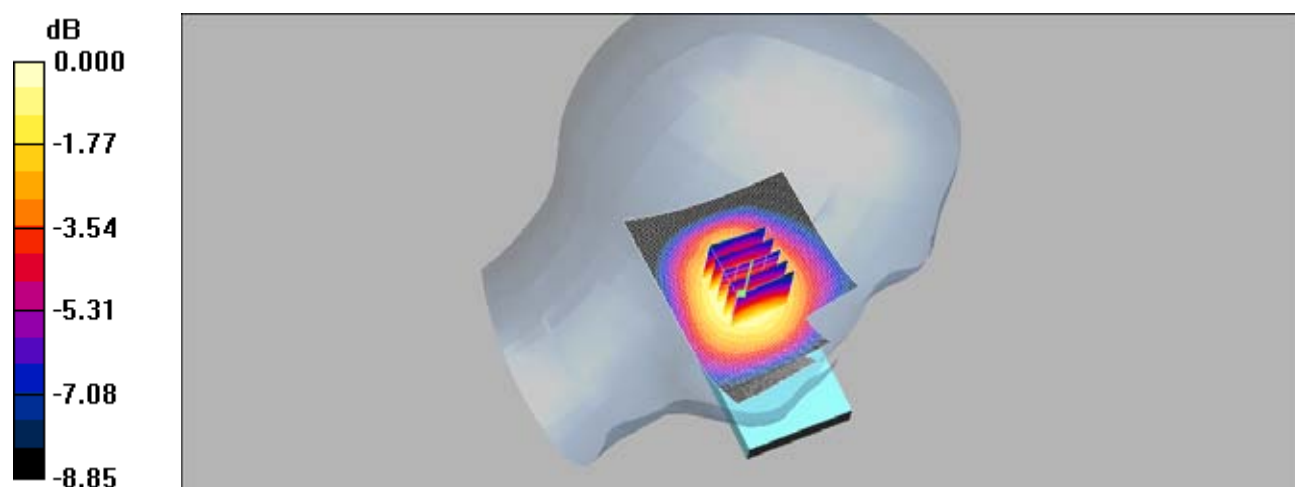

0 dB = 0.217mW/g

Date/Time: 2008/11/25 09:26:22

BODY_CH128

DUT: SAPP100;

Communication System: GSM 850; Frequency: 824.2 MHz; Duty Cycle: 1:2

Medium: Muscle 900 MHz Medium parameters used (interpolated): $f = 824.2$ MHz; $\sigma = 0.942$ mho/m; $\epsilon_r = 54.4$; $\rho = 1000$ kg/m³

Phantom section: Flat Section

DASY4 Configuration:

- Probe: EX3DV3 - SN3526; ConvF(10.87, 10.87, 10.87); Calibrated: 2008/8/26
- Sensor-Surface: 4mm (Mechanical Surface Detection)
- Electronics: DAE4 Sn547; Calibrated: 2008/1/24
- Phantom: SAM1; Type: SAM 4.0; Serial: TP:1419
- Measurement SW: DASY4, V4.7 Build 71; Postprocessing SW: SEMCAD, V1.8 Build 184

BODY/Area Scan (51x91x1): Measurement grid: dx=15mm, dy=15mm

Maximum value of SAR (interpolated) = 0.517 mW/g

BODY/Zoom Scan (5x5x7)/Cube 0: Measurement grid: dx=8mm, dy=8mm, dz=5mm

Reference Value = 7.18 V/m; Power Drift = 0.071 dB

Peak SAR (extrapolated) = 0.677 W/kg

SAR(1 g) = 0.467 mW/g; SAR(10 g) = 0.335 mW/g

Maximum value of SAR (measured) = 0.491 mW/g

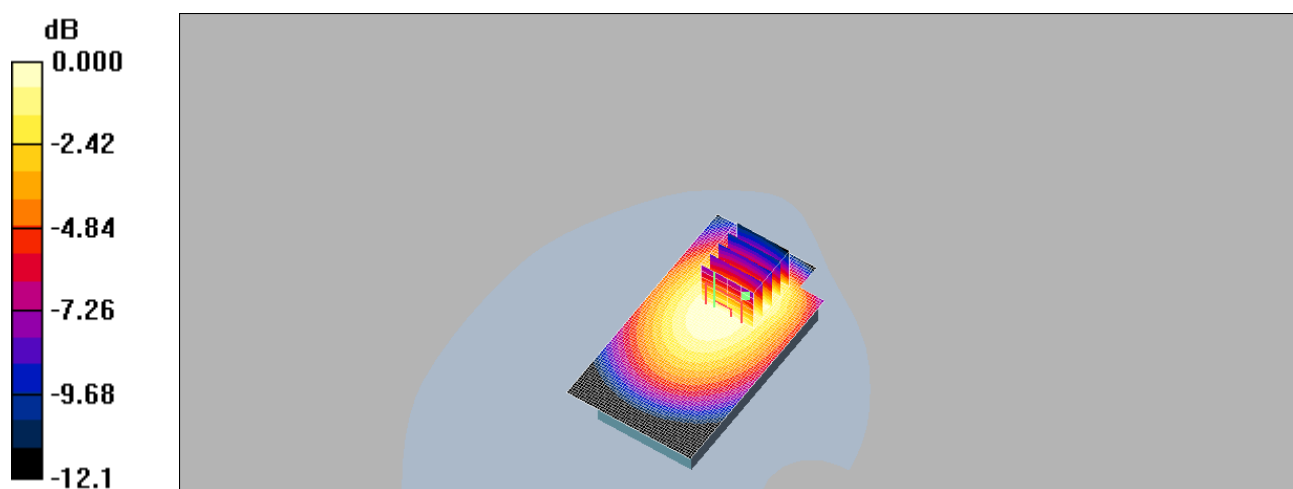

0 dB = 0.491mW/g

Date/Time: 2008/11/25 09:59:53

BODY_CH190

DUT: SAPP100;

Communication System: GSM 850; Frequency: 836.6 MHz; Duty Cycle: 1:2

Medium: Muscle 900 MHz Medium parameters used (interpolated): $f = 836.6$ MHz; $\sigma = 0.946$ mho/m; $\epsilon_r = 54.3$; $\rho = 1000$ kg/m³

Phantom section: Flat Section

DASY4 Configuration:

- Probe: EX3DV3 - SN3526; ConvF(10.87, 10.87, 10.87); Calibrated: 2008/8/26
- Sensor-Surface: 4mm (Mechanical Surface Detection)
- Electronics: DAE4 Sn547; Calibrated: 2008/1/24
- Phantom: SAM1; Type: SAM 4.0; Serial: TP:1419
- Measurement SW: DASY4, V4.7 Build 71; Postprocessing SW: SEMCAD, V1.8 Build 184

BODY/Area Scan (51x91x1): Measurement grid: dx=15mm, dy=15mm

Maximum value of SAR (interpolated) = 0.621 mW/g

BODY/Zoom Scan (5x5x7)/Cube 0: Measurement grid: dx=8mm, dy=8mm, dz=5mm

Reference Value = 8.01 V/m; Power Drift = 0.008 dB

Peak SAR (extrapolated) = 0.815 W/kg

SAR(1 g) = 0.576 mW/g; SAR(10 g) = 0.408 mW/g

Maximum value of SAR (measured) = 0.608 mW/g

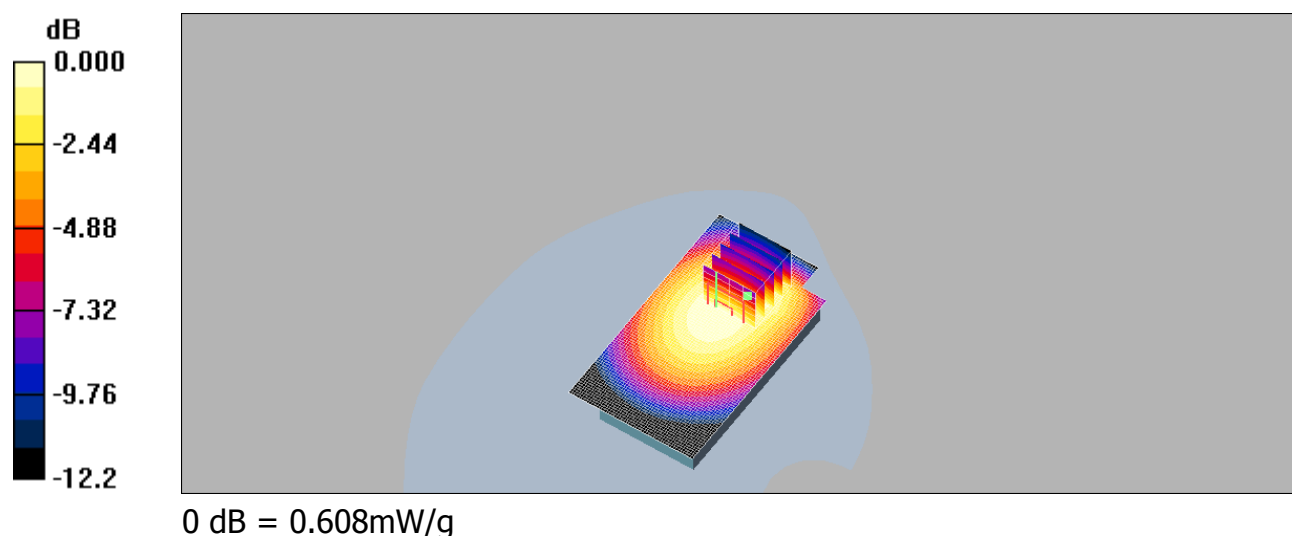

Date/Time: 2008/11/25 10:23:39

BODY_CH251

DUT: SAPP100;

Communication System: GSM 850; Frequency: 848.8 MHz; Duty Cycle: 1:2

Medium: Muscle 900 MHz Medium parameters used (interpolated): $f = 848.8$ MHz; $\sigma = 0.951$ mho/m; $\epsilon_r = 54.1$; $\rho = 1000$ kg/m³

Phantom section: Flat Section

- Probe: EX3DV3 - SN3526; ConvF(10.87, 10.87, 10.87); Calibrated: 2008/8/26
- Sensor-Surface: 4mm (Mechanical Surface Detection)
- Electronics: DAE4 Sn547; Calibrated: 2008/1/24
- Phantom: SAM1; Type: SAM 4.0; Serial: TP:1419
- Measurement SW: DASY4, V4.7 Build 71; Postprocessing SW: SEMCAD, V1.8 Build 184

BODY/Area Scan (51x91x1): Measurement grid: dx=15mm, dy=15mm

Maximum value of SAR (interpolated) = 0.855 mW/g

BODY/Zoom Scan (5x5x7)/Cube 0: Measurement grid: dx=8mm, dy=8mm, dz=5mm

Reference Value = 9.58 V/m; Power Drift = 0.015 dB

Peak SAR (extrapolated) = 1.10 W/kg

SAR(1 g) = 0.794 mW/g; SAR(10 g) = 0.560 mW/g

Maximum value of SAR (measured) = 0.847 mW/g

BODY/Zoom Scan (5x5x7)/Cube 1: Measurement grid: dx=8mm, dy=8mm, dz=5mm

Reference Value = 9.58 V/m; Power Drift = 0.015 dB

Peak SAR (extrapolated) = 1.05 W/kg

SAR(1 g) = 0.800 mW/g; SAR(10 g) = 0.584 mW/g

Maximum value of SAR (measured) = 0.843 mW/g

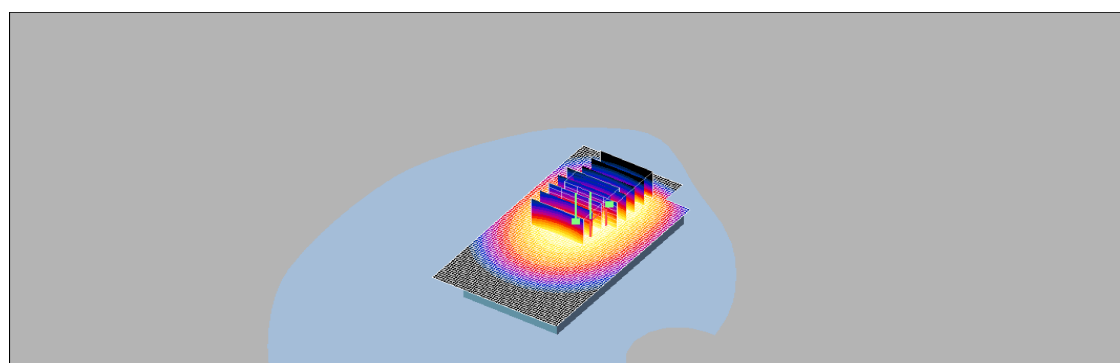
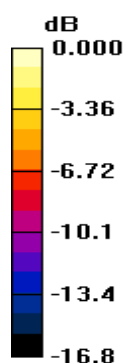

0 dB = 0.843mW/g

Date/Time: 2008/11/26 01:23:17

Re Cheek_CH512

DUT: SAPP100;

Communication System: GSM1900; Frequency: 1850.2 MHz; Duty Cycle: 1:8.3
Medium: Head 1900 MHz Medium parameters used (interpolated): $f = 1850.2$ MHz; $\sigma = 1.41$ mho/m; $\epsilon_r = 41.5$; $\rho = 1000$ kg/m³
Phantom section: Right Section

DASY4 Configuration:

- Probe: EX3DV3 - SN3526; ConvF(9.46, 9.46, 9.46); Calibrated: 2008/8/26
- Sensor-Surface: 4mm (Mechanical Surface Detection)
- Electronics: DAE4 Sn547; Calibrated: 2008/1/24
- Phantom: SAM1; Type: SAM 4.0; Serial: TP:1419
- Measurement SW: DASY4, V4.7 Build 71; Postprocessing SW: SEMCAD, V1.8 Build 184

RE Cheek/Area Scan (61x91x1): Measurement grid: dx=15mm, dy=15mm
Maximum value of SAR (interpolated) = 0.689 mW/g

RE Cheek/Zoom Scan (5x5x7)/Cube 0: Measurement grid: dx=8mm, dy=8mm, dz=5mm

Reference Value = 9.94 V/m; Power Drift = -0.147 dB

Peak SAR (extrapolated) = 0.905 W/kg

SAR(1 g) = 0.629 mW/g; SAR(10 g) = 0.401 mW/g

Maximum value of SAR (measured) = 0.665 mW/g

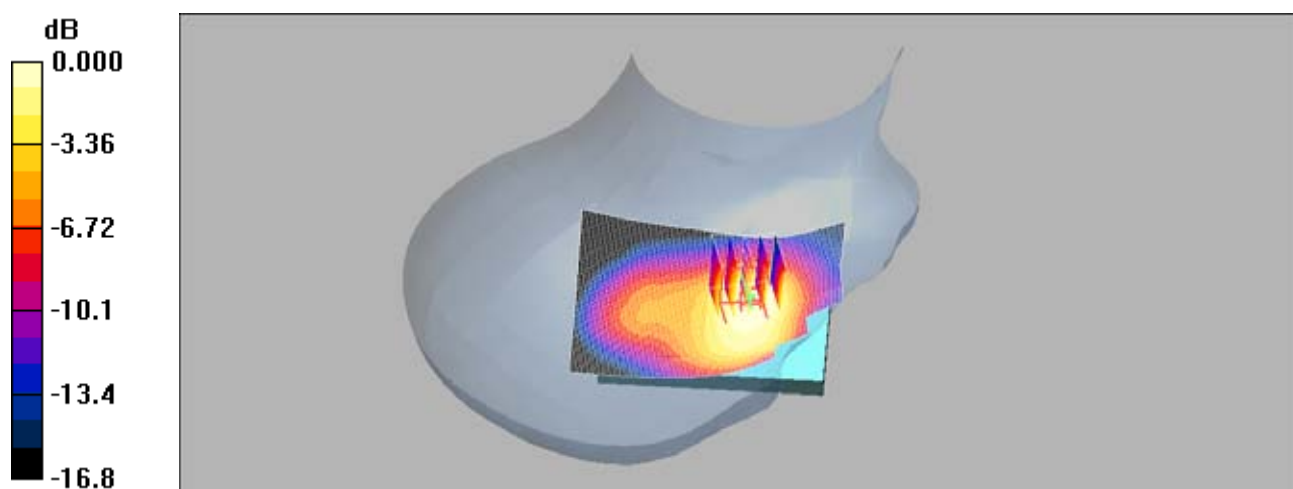

0 dB = 0.665mW/g

Date/Time: 2008/11/26 01:48:03

Re Cheek_CH661

DUT: SAPP100;

Communication System: GSM1900; Frequency: 1880 MHz; Duty Cycle: 1:8.3

Medium: Head 1900 MHz Medium parameters used: $f = 1880$ MHz; $\sigma = 1.43$ mho/m; $\epsilon_r = 41.3$; $\rho = 1000$ kg/m³

Phantom section: Right Section

DASY4 Configuration:

- Probe: EX3DV3 - SN3526; ConvF(9.46, 9.46, 9.46); Calibrated: 2008/8/26
- Sensor-Surface: 4mm (Mechanical Surface Detection)
- Electronics: DAE4 Sn547; Calibrated: 2008/1/24
- Phantom: SAM1; Type: SAM 4.0; Serial: TP:1419
- Measurement SW: DASY4, V4.7 Build 71; Postprocessing SW: SEMCAD, V1.8 Build 184

RE Cheek/Area Scan (61x91x1): Measurement grid: dx=15mm, dy=15mm

Maximum value of SAR (interpolated) = 0.705 mW/g

RE Cheek/Zoom Scan (5x5x7)/Cube 0: Measurement grid: dx=8mm, dy=8mm, dz=5mm

Reference Value = 10.1 V/m; Power Drift = -0.085 dB

Peak SAR (extrapolated) = 0.941 W/kg

SAR(1 g) = 0.646 mW/g; SAR(10 g) = 0.406 mW/g

Maximum value of SAR (measured) = 0.687 mW/g

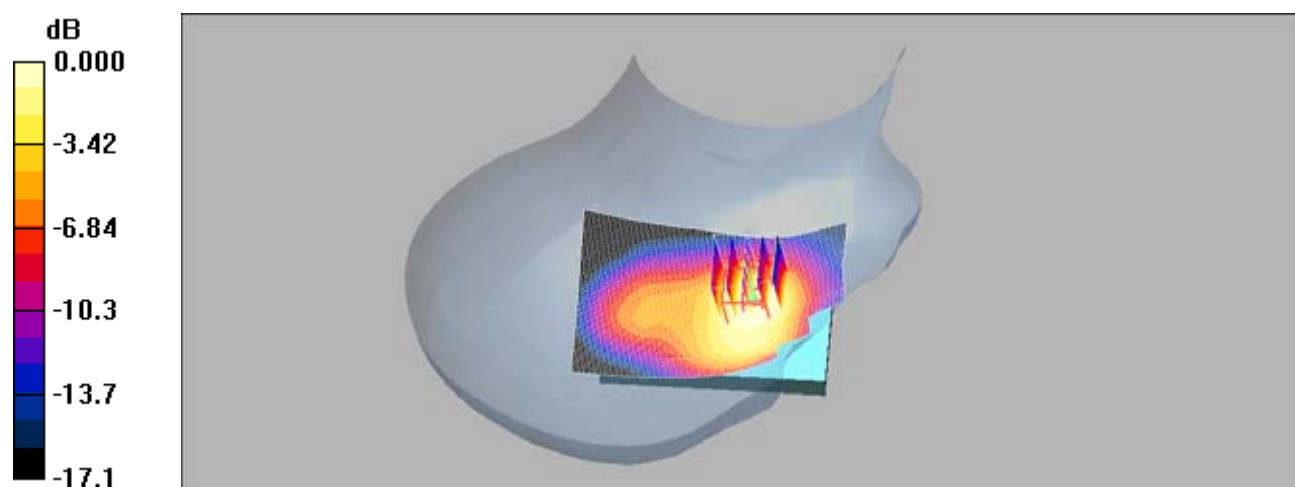

0 dB = 0.687mW/g

Date/Time: 2008/11/26 02:29:16

Re Cheek_CH810

DUT: SAPP100;

Communication System: GSM1900; Frequency: 1909.8 MHz; Duty Cycle: 1:8.3

Medium: Head 1900 MHz Medium parameters used: $f = 1910$ MHz; $\sigma = 1.45$ mho/m; $\epsilon_r = 41.2$; $\rho = 1000$ kg/m³

Phantom section: Right Section

DASY4 Configuration:

- Probe: EX3DV3 - SN3526; ConvF(9.46, 9.46, 9.46); Calibrated: 2008/8/26
- Sensor-Surface: 4mm (Mechanical Surface Detection)
- Electronics: DAE4 Sn547; Calibrated: 2008/1/24
- Phantom: SAM1; Type: SAM 4.0; Serial: TP:1419
- Measurement SW: DASY4, V4.7 Build 71; Postprocessing SW: SEMCAD, V1.8 Build 184

RE Cheek/Area Scan (61x91x1): Measurement grid: dx=15mm, dy=15mm

Maximum value of SAR (interpolated) = 0.733 mW/g

RE Cheek/Zoom Scan (5x5x7)/Cube 0: Measurement grid: dx=8mm, dy=8mm, dz=5mm

Reference Value = 10.5 V/m; Power Drift = -0.089 dB

Peak SAR (extrapolated) = 0.970 W/kg

SAR(1 g) = 0.666 mW/g; SAR(10 g) = 0.414 mW/g

Maximum value of SAR (measured) = 0.705 mW/g

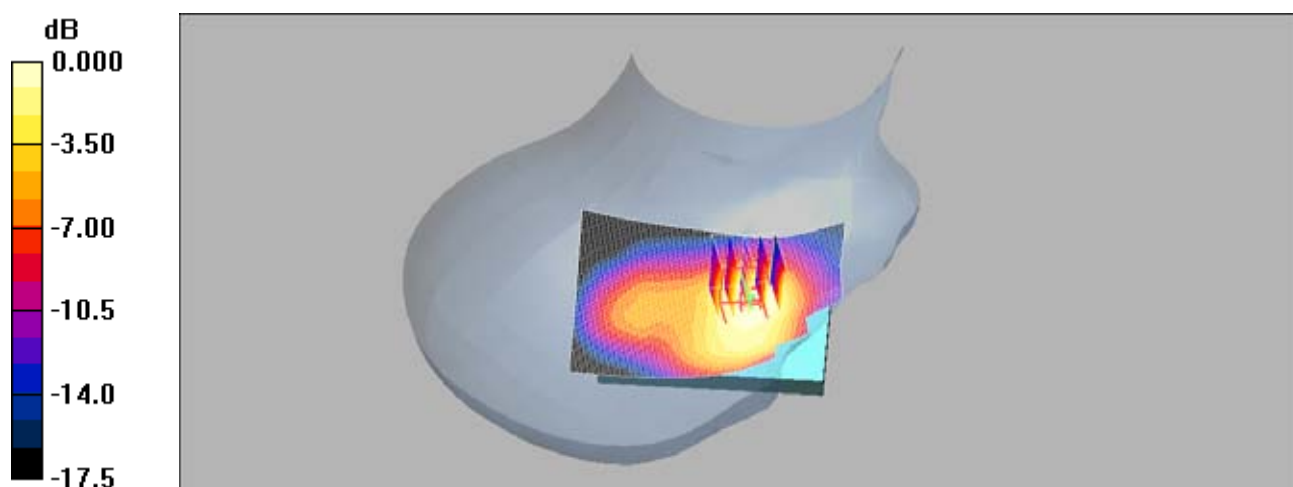

0 dB = 0.705mW/g

Date/Time: 2008/11/26 04:36:53

Le Cheek_CH512

DUT: SAPP100;

Communication System: GSM1900; Frequency: 1850.2 MHz; Duty Cycle: 1:8.3
Medium: Head 1900 MHz Medium parameters used (interpolated): $f = 1850.2$ MHz; $\sigma = 1.41$ mho/m; $\epsilon_r = 41.5$; $\rho = 1000$ kg/m³
Phantom section: Left Section

DASY4 Configuration:

- Probe: EX3DV3 - SN3526; ConvF(9.46, 9.46, 9.46); Calibrated: 2008/8/26
- Sensor-Surface: 4mm (Mechanical Surface Detection)
- Electronics: DAE4 Sn547; Calibrated: 2008/1/24
- Phantom: SAM1; Type: SAM 4.0; Serial: TP:1419
- Measurement SW: DASY4, V4.7 Build 71; Postprocessing SW: SEMCAD, V1.8 Build 184

LE Cheek/Area Scan (61x91x1): Measurement grid: dx=15mm, dy=15mm
Maximum value of SAR (interpolated) = 0.737 mW/g

LE Cheek/Zoom Scan (5x5x7)/Cube 0: Measurement grid: dx=8mm, dy=8mm, dz=5mm

Reference Value = 8.20 V/m; Power Drift = -0.156 dB

Peak SAR (extrapolated) = 1.04 W/kg

SAR(1 g) = 0.643 mW/g; SAR(10 g) = 0.396 mW/g

Maximum value of SAR (measured) = 0.694 mW/g

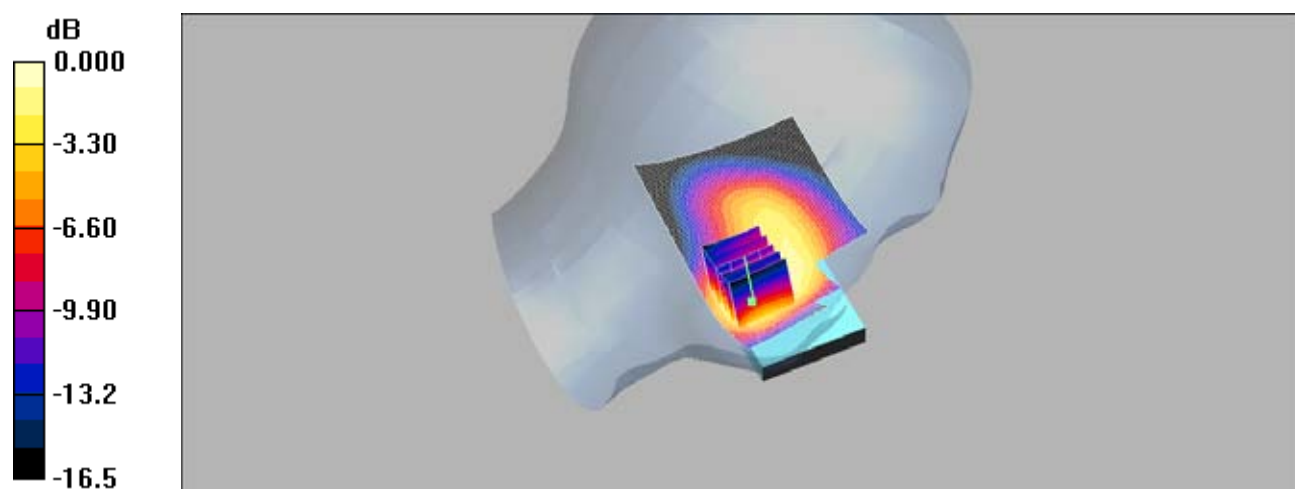

0 dB = 0.694mW/g

Date/Time: 2008/11/26 05:05:45

Le Cheek_CH661

DUT: SAPP100;

Communication System: GSM1900; Frequency: 1880 MHz; Duty Cycle: 1:8.3

Medium: Head 1900 MHz Medium parameters used: $f = 1880$ MHz; $\sigma = 1.43$ mho/m; $\epsilon_r = 41.3$; $\rho = 1000$ kg/m³

Phantom section: Left Section

DASY4 Configuration:

- Probe: EX3DV3 - SN3526; ConvF(9.46, 9.46, 9.46); Calibrated: 2008/8/26
- Sensor-Surface: 4mm (Mechanical Surface Detection)
- Electronics: DAE4 Sn547; Calibrated: 2008/1/24
- Phantom: SAM1; Type: SAM 4.0; Serial: TP:1419
- Measurement SW: DASY4, V4.7 Build 71; Postprocessing SW: SEMCAD, V1.8 Build 184

LE Cheek/Area Scan (61x91x1): Measurement grid: dx=15mm, dy=15mm

Maximum value of SAR (interpolated) = 0.729 mW/g

LE Cheek/Zoom Scan (5x5x7)/Cube 0: Measurement grid: dx=8mm, dy=8mm, dz=5mm

Reference Value = 8.09 V/m; Power Drift = -0.045 dB

Peak SAR (extrapolated) = 1.07 W/kg

SAR(1 g) = 0.654 mW/g; SAR(10 g) = 0.397 mW/g

Maximum value of SAR (measured) = 0.709 mW/g

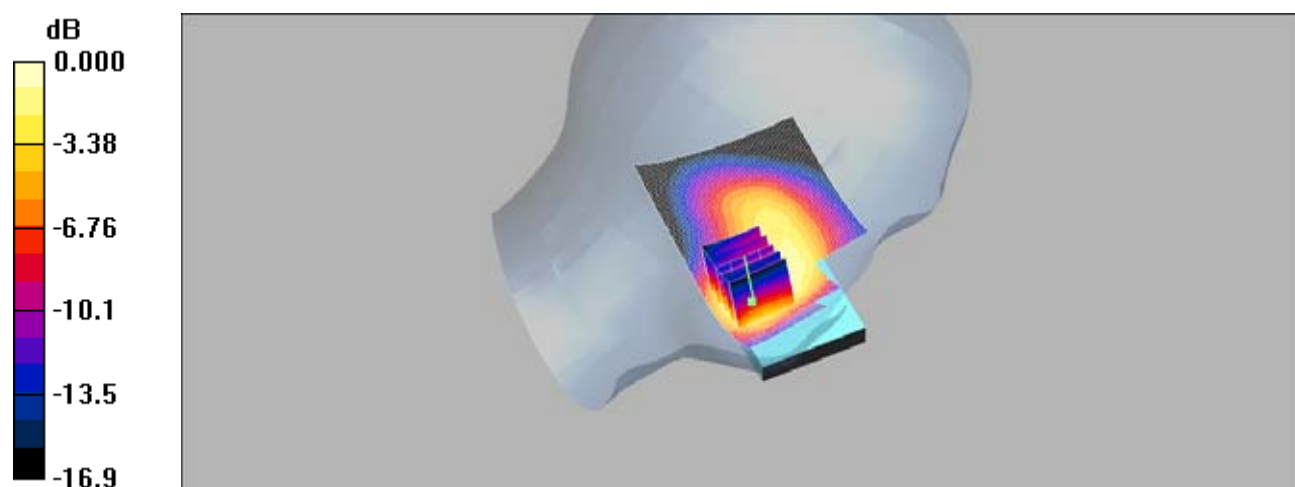

0 dB = 0.709mW/g

Date/Time: 2008/11/26 05:38:10

Le Cheek_CH810

DUT: SAPP100;

Communication System: GSM1900; Frequency: 1909.8 MHz; Duty Cycle: 1:8.3

Medium: Head 1900 MHz Medium parameters used: $f = 1910$ MHz; $\sigma = 1.45$ mho/m; $\epsilon_r = 41.2$; $\rho = 1000$ kg/m³

Phantom section: Left Section

DASY4 Configuration:

- Probe: EX3DV3 - SN3526; ConvF(9.46, 9.46, 9.46); Calibrated: 2008/8/26
- Sensor-Surface: 4mm (Mechanical Surface Detection)
- Electronics: DAE4 Sn547; Calibrated: 2008/1/24
- Phantom: SAM1; Type: SAM 4.0; Serial: TP:1419
- Measurement SW: DASY4, V4.7 Build 71; Postprocessing SW: SEMCAD, V1.8 Build 184

LE Cheek/Area Scan (61x91x1): Measurement grid: dx=15mm, dy=15mm

Maximum value of SAR (interpolated) = 0.745 mW/g

LE Cheek/Zoom Scan (5x5x7)/Cube 0: Measurement grid: dx=8mm, dy=8mm, dz=5mm

Reference Value = 8.48 V/m; Power Drift = -0.079 dB

Peak SAR (extrapolated) = 1.11 W/kg

SAR(1 g) = 0.675 mW/g; SAR(10 g) = 0.401 mW/g

Maximum value of SAR (measured) = 0.741 mW/g

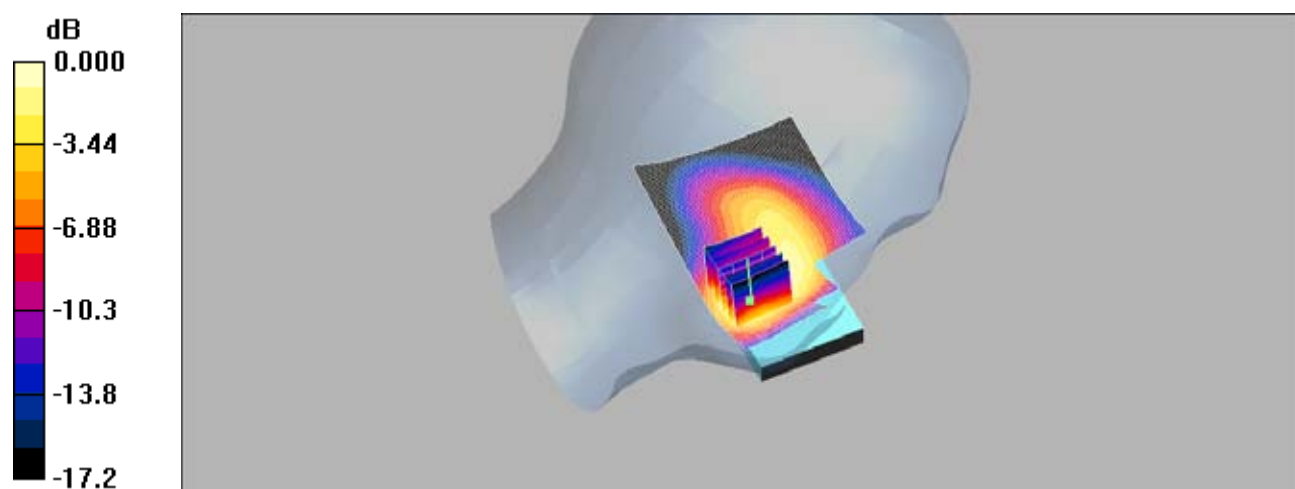

0 dB = 0.741mW/g



Date/Time: 2008/11/26 02:56:17

Re Tilt_CH512

DUT: SAPP100;

Communication System: GSM1900; Frequency: 1850.2 MHz; Duty Cycle: 1:8.3

Medium: Head 1900 MHz Medium parameters used (interpolated): $f = 1850.2$ MHz; $\sigma = 1.41$ mho/m; $\epsilon_r = 41.5$; $\rho = 1000$ kg/m³

Phantom section: Right Section

DASY4 Configuration:

- Probe: EX3DV3 - SN3526; ConvF(9.46, 9.46, 9.46); Calibrated: 2008/8/26
- Sensor-Surface: 4mm (Mechanical Surface Detection)
- Electronics: DAE4 Sn547; Calibrated: 2008/1/24
- Phantom: SAM1; Type: SAM 4.0; Serial: TP:1419
- Measurement SW: DASY4, V4.7 Build 71; Postprocessing SW: SEMCAD, V1.8 Build 184

RE Tilt/Area Scan (61x91x1): Measurement grid: dx=15mm, dy=15mm

Maximum value of SAR (interpolated) = 0.343 mW/g

RE Tilt/Zoom Scan (5x5x7)/Cube 0: Measurement grid: dx=8mm, dy=8mm, dz=5mm

Reference Value = 15.1 V/m; Power Drift = 0.030 dB

Peak SAR (extrapolated) = 0.461 W/kg

SAR(1 g) = 0.307 mW/g; SAR(10 g) = 0.193 mW/g

Maximum value of SAR (measured) = 0.329 mW/g

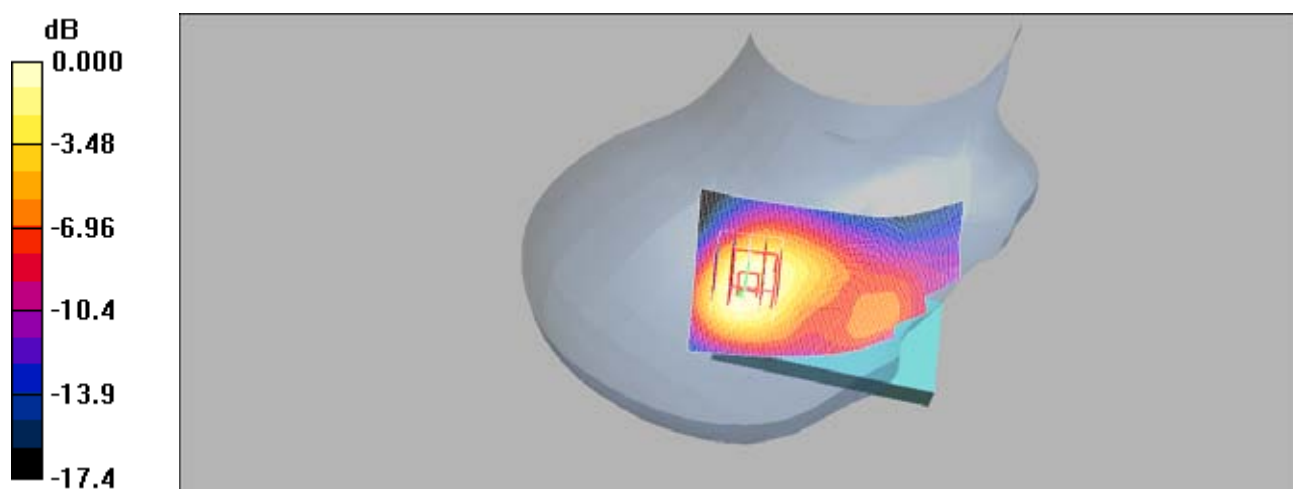

0 dB = 0.329mW/g

Date/Time: 2008/11/26 03:23:40

Re Tilt_CH661

DUT: SAPP100;

Communication System: GSM1900; Frequency: 1880 MHz; Duty Cycle: 1:8.3

Medium: Head 1900 MHz Medium parameters used: $f = 1880$ MHz; $\sigma = 1.43$ mho/m; $\epsilon_r = 41.3$; $\rho = 1000$ kg/m³

Phantom section: Right Section

DASY4 Configuration:

- Probe: EX3DV3 - SN3526; ConvF(9.46, 9.46, 9.46); Calibrated: 2008/8/26
- Sensor-Surface: 4mm (Mechanical Surface Detection)
- Electronics: DAE4 Sn547; Calibrated: 2008/1/24
- Phantom: SAM1; Type: SAM 4.0; Serial: TP:1419
- Measurement SW: DASY4, V4.7 Build 71; Postprocessing SW: SEMCAD, V1.8 Build 184

RE Tilt/Area Scan (61x91x1): Measurement grid: dx=15mm, dy=15mm

Maximum value of SAR (interpolated) = 0.363 mW/g

RE Tilt/Zoom Scan (5x5x7)/Cube 0: Measurement grid: dx=8mm, dy=8mm, dz=5mm

Reference Value = 15.5 V/m; Power Drift = -0.038 dB

Peak SAR (extrapolated) = 0.488 W/kg

SAR(1 g) = 0.323 mW/g; SAR(10 g) = 0.200 mW/g

Maximum value of SAR (measured) = 0.349 mW/g

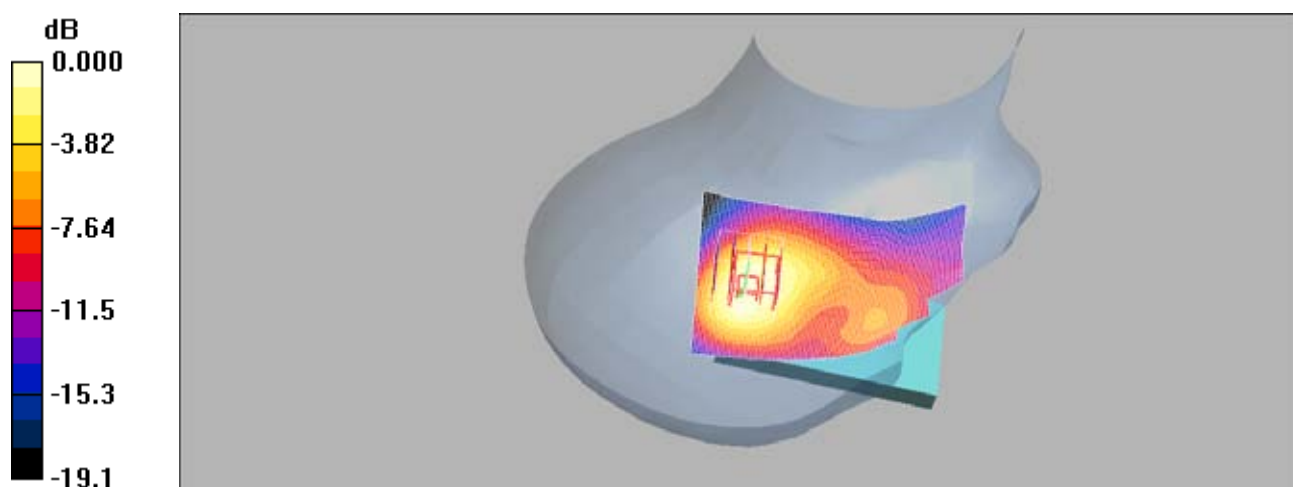

Date/Time: 2008/11/26 03:59:00

Re Tilt_CH810

DUT: SAPP100;

Communication System: GSM1900; Frequency: 1909.8 MHz; Duty Cycle: 1:8.3

Medium: Head 1900 MHz Medium parameters used: $f = 1910$ MHz; $\sigma = 1.45$ mho/m; $\epsilon_r = 41.2$; $\rho = 1000$ kg/m³

Phantom section: Right Section

DASY4 Configuration:

- Probe: EX3DV3 - SN3526; ConvF(9.46, 9.46, 9.46); Calibrated: 2008/8/26
- Sensor-Surface: 4mm (Mechanical Surface Detection)
- Electronics: DAE4 Sn547; Calibrated: 2008/1/24
- Phantom: SAM1; Type: SAM 4.0; Serial: TP:1419
- Measurement SW: DASY4, V4.7 Build 71; Postprocessing SW: SEMCAD, V1.8 Build 184

RE Tilt/Area Scan (61x91x1): Measurement grid: dx=15mm, dy=15mm

Maximum value of SAR (interpolated) = 0.410 mW/g

RE Tilt/Zoom Scan (5x5x7)/Cube 0: Measurement grid: dx=8mm, dy=8mm, dz=5mm

Reference Value = 16.2 V/m; Power Drift = 0.019 dB

Peak SAR (extrapolated) = 0.551 W/kg

SAR(1 g) = 0.358 mW/g; SAR(10 g) = 0.218 mW/g

Maximum value of SAR (measured) = 0.390 mW/g

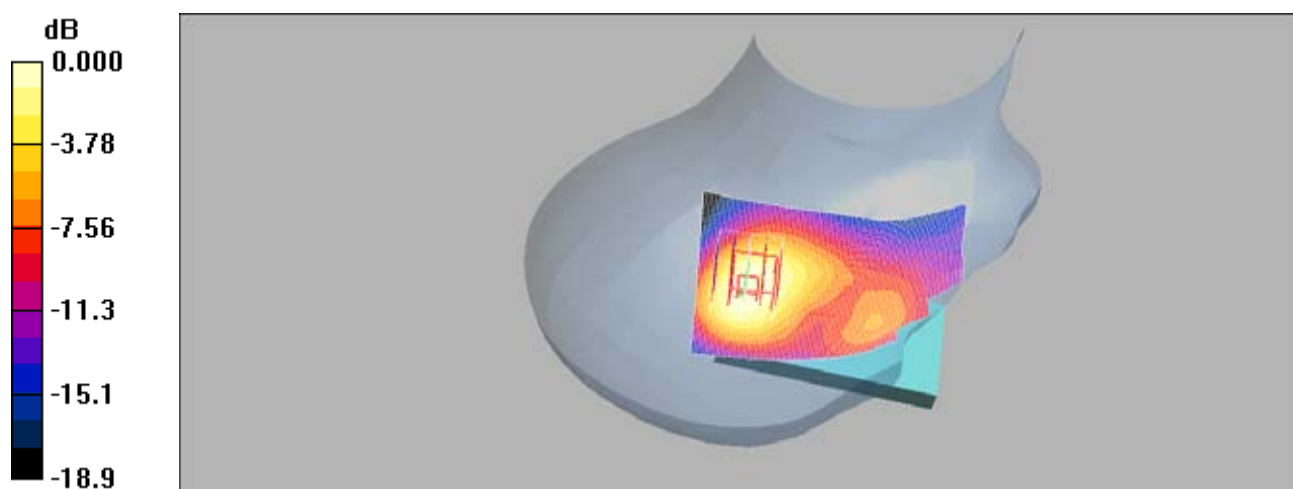

0 dB = 0.390mW/g

Date/Time: 2008/11/26 06:02:59

Le Tilt_CH512

DUT: SAPP100;

Communication System: GSM1900; Frequency: 1850.2 MHz; Duty Cycle: 1:8.3

Medium: Head 1900 MHz Medium parameters used (interpolated): $f = 1850.2$ MHz; $\sigma = 1.41$ mho/m; $\epsilon_r = 41.5$; $\rho = 1000$ kg/m³

Phantom section: Left Section

DASY4 Configuration:

- Probe: EX3DV3 - SN3526; ConvF(9.46, 9.46, 9.46); Calibrated: 2008/8/26
- Sensor-Surface: 4mm (Mechanical Surface Detection)
- Electronics: DAE4 Sn547; Calibrated: 2008/1/24
- Phantom: SAM1; Type: SAM 4.0; Serial: TP:1419
- Measurement SW: DASY4, V4.7 Build 71; Postprocessing SW: SEMCAD, V1.8 Build 184

LETilt/Area Scan (61x91x1): Measurement grid: dx=15mm, dy=15mm

Maximum value of SAR (interpolated) = 0.412 mW/g

LETilt/Zoom Scan (5x5x7)/Cube 0: Measurement grid: dx=8mm, dy=8mm, dz=5mm

Reference Value = 13.4 V/m; Power Drift = 0.021 dB

Peak SAR (extrapolated) = 0.530 W/kg

SAR(1 g) = 0.357 mW/g; SAR(10 g) = 0.224 mW/g

Maximum value of SAR (measured) = 0.383 mW/g

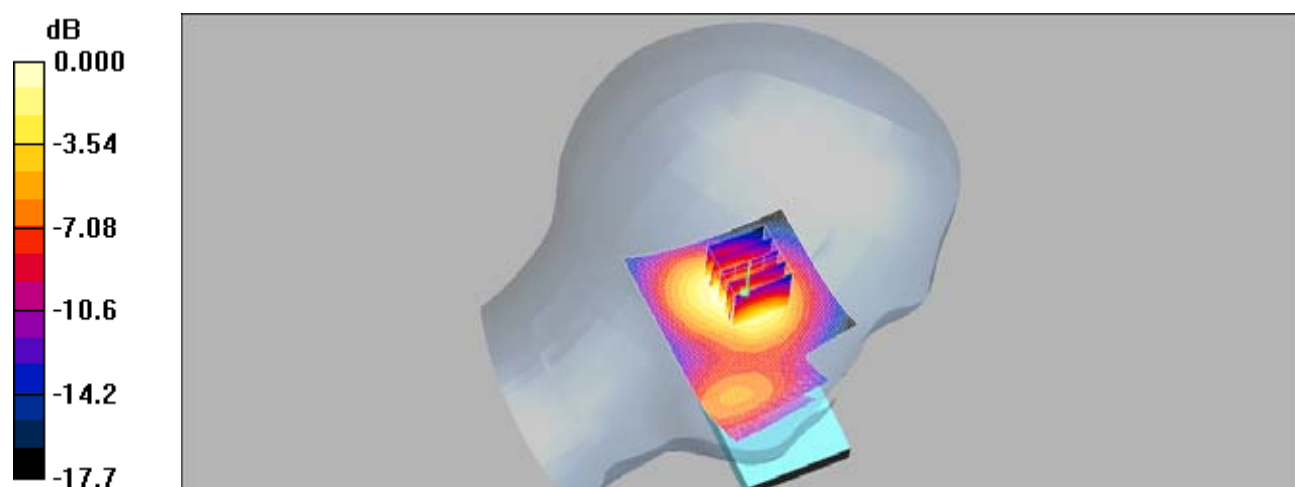

Date/Time: 2008/11/26 06:33:49

Le Tilt_CH661

DUT: SAPP100;

Communication System: GSM1900; Frequency: 1880 MHz;Duty Cycle: 1:8.3

Medium: Head 1900 MHz Medium parameters used: $f = 1880$ MHz; $\sigma = 1.43$ mho/m; $\epsilon_r = 41.3$; $\rho = 1000$ kg/m³

Phantom section: Left Section

DASY4 Configuration:

- Probe: EX3DV3 - SN3526; ConvF(9.46, 9.46, 9.46); Calibrated: 2008/8/26
- Sensor-Surface: 4mm (Mechanical Surface Detection)
- Electronics: DAE4 Sn547; Calibrated: 2008/1/24
- Phantom: SAM1; Type: SAM 4.0; Serial: TP:1419
- Measurement SW: DASY4, V4.7 Build 71; Postprocessing SW: SEMCAD, V1.8 Build 184

LETilt/Area Scan (61x91x1): Measurement grid: dx=15mm, dy=15mm

Maximum value of SAR (interpolated) = 0.426 mW/g

LETilt/Zoom Scan (5x5x7)/Cube 0: Measurement grid: dx=8mm, dy=8mm, dz=5mm

Reference Value = 13.9 V/m; Power Drift = -0.192 dB

Peak SAR (extrapolated) = 0.556 W/kg

SAR(1 g) = 0.367 mW/g; SAR(10 g) = 0.227 mW/g

Maximum value of SAR (measured) = 0.392 mW/g

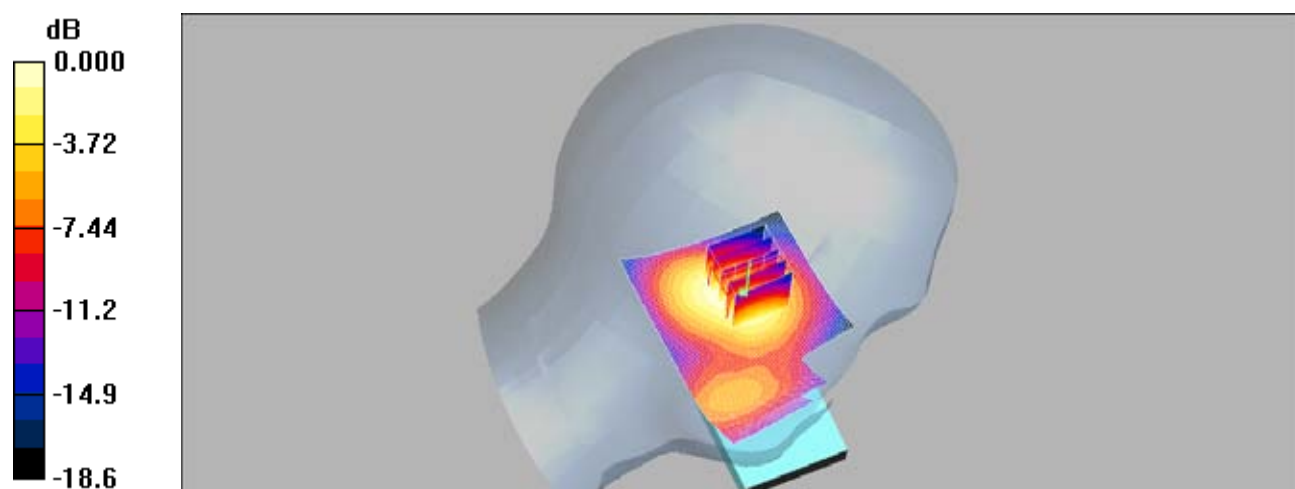

0 dB = 0.392mW/g

Date/Time: 2008/11/26 07:02:41

Le Tilt_CH810

DUT: SAPP100;

Communication System: GSM1900; Frequency: 1909.8 MHz; Duty Cycle: 1:8.3

Medium: Head 1900 MHz Medium parameters used: $f = 1910$ MHz; $\sigma = 1.45$ mho/m; $\epsilon_r = 41.2$; $\rho = 1000$ kg/m³

Phantom section: Left Section

DASY4 Configuration:

- Probe: EX3DV3 - SN3526; ConvF(9.46, 9.46, 9.46); Calibrated: 2008/8/26
- Sensor-Surface: 4mm (Mechanical Surface Detection)
- Electronics: DAE4 Sn547; Calibrated: 2008/1/24
- Phantom: SAM1; Type: SAM 4.0; Serial: TP:1419
- Measurement SW: DASY4, V4.7 Build 71; Postprocessing SW: SEMCAD, V1.8 Build 184

LE Tilt/Area Scan (61x91x1): Measurement grid: dx=15mm, dy=15mm

Maximum value of SAR (interpolated) = 0.441 mW/g

LE Tilt/Zoom Scan (5x5x7)/Cube 0: Measurement grid: dx=8mm, dy=8mm, dz=5mm

Reference Value = 14.3 V/m; Power Drift = 0.109 dB

Peak SAR (extrapolated) = 0.576 W/kg

SAR(1 g) = 0.379 mW/g; SAR(10 g) = 0.233 mW/g

Maximum value of SAR (measured) = 0.407 mW/g

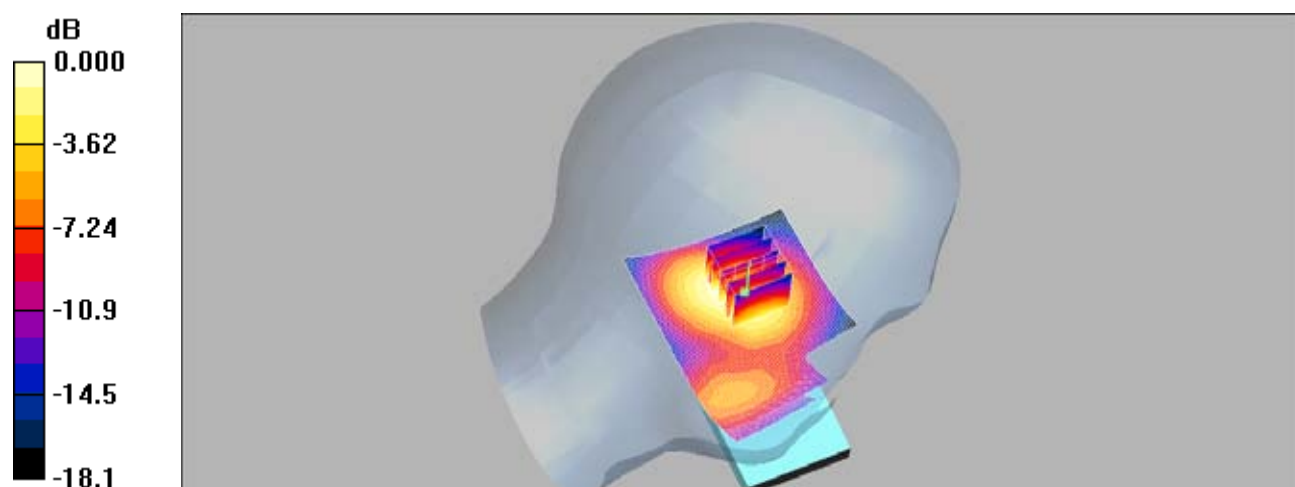

Date/Time: 2008/11/26 07:42:09

Le Cheek_CH810_repeated with Memory card

DUT: SAPP100;

Communication System: GSM1900; Frequency: 1909.8 MHz; Duty Cycle: 1:8.3
Medium: Head 1900 MHz Medium parameters used: $f = 1910$ MHz; $\sigma = 1.45$ mho/m; $\epsilon_r = 41.2$; $\rho = 1000$ kg/m³
Phantom section: Left Section

DASY4 Configuration:

- Probe: EX3DV3 - SN3526; ConvF(9.46, 9.46, 9.46); Calibrated: 2008/8/26
- Sensor-Surface: 4mm (Mechanical Surface Detection)
- Electronics: DAE4 Sn547; Calibrated: 2008/1/24
- Phantom: SAM1; Type: SAM 4.0; Serial: TP:1419
- Measurement SW: DASY4, V4.7 Build 71; Postprocessing SW: SEMCAD, V1.8 Build 184

LE Cheek/Area Scan (61x91x1): Measurement grid: dx=15mm, dy=15mm
Maximum value of SAR (interpolated) = 0.771 mW/g

LE Cheek/Zoom Scan (5x5x7)/Cube 0: Measurement grid: dx=8mm, dy=8mm, dz=5mm

Reference Value = 7.66 V/m; Power Drift = -0.159 dB

Peak SAR (extrapolated) = 1.14 W/kg

SAR(1 g) = 0.674 mW/g; SAR(10 g) = 0.405 mW/g

Maximum value of SAR (measured) = 0.734 mW/g

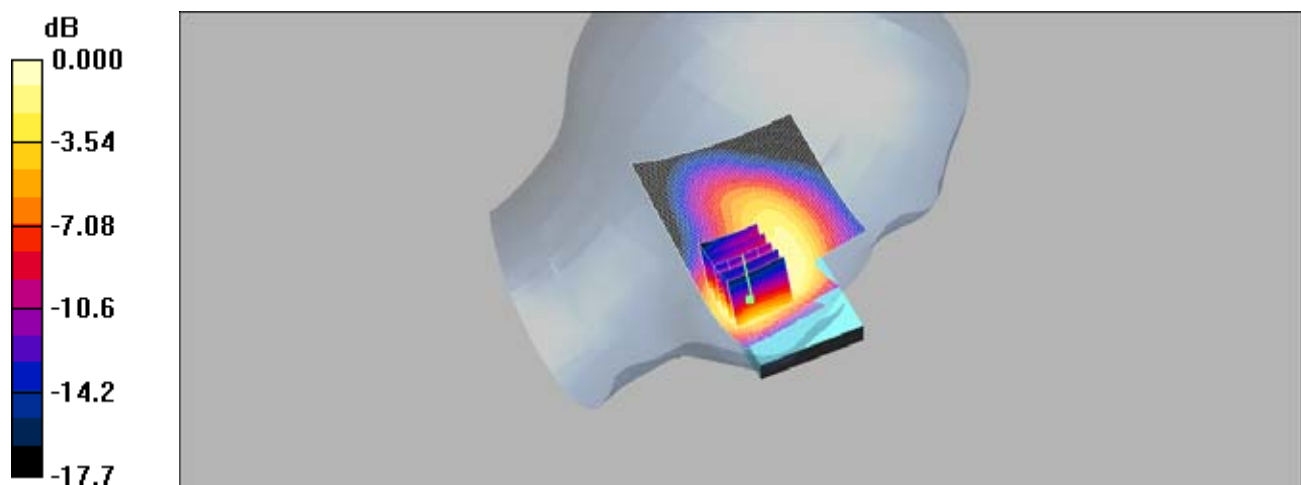

0 dB = 0.734mW/g

Date/Time: 2008/11/26 08:19:49

Le Cheek_CH810_repeated with Bluetooth active

DUT: SAPP100;

Communication System: GSM1900; Frequency: 1909.8 MHz; Duty Cycle: 1:8.3

Medium: Head 1900 MHz Medium parameters used: $f = 1910$ MHz; $\sigma = 1.45$ mho/m; $\epsilon_r = 41.2$; $\rho = 1000$ kg/m³

Phantom section: Left Section

DASY4 Configuration:

- Probe: EX3DV3 - SN3526; ConvF(9.46, 9.46, 9.46); Calibrated: 2008/8/26
- Sensor-Surface: 4mm (Mechanical Surface Detection)
- Electronics: DAE4 Sn547; Calibrated: 2008/1/24
- Phantom: SAM1; Type: SAM 4.0; Serial: TP:1419
- Measurement SW: DASY4, V4.7 Build 71; Postprocessing SW: SEMCAD, V1.8 Build 184

LE Cheek/Area Scan (61x91x1): Measurement grid: dx=15mm, dy=15mm

Maximum value of SAR (interpolated) = 0.772 mW/g

LE Cheek/Zoom Scan (5x5x7)/Cube 0: Measurement grid: dx=8mm, dy=8mm, dz=5mm

Reference Value = 7.90 V/m; Power Drift = -0.159 dB

Peak SAR (extrapolated) = 1.11 W/kg

SAR(1 g) = 0.660 mW/g; SAR(10 g) = 0.394 mW/g

Maximum value of SAR (measured) = 0.717 mW/g

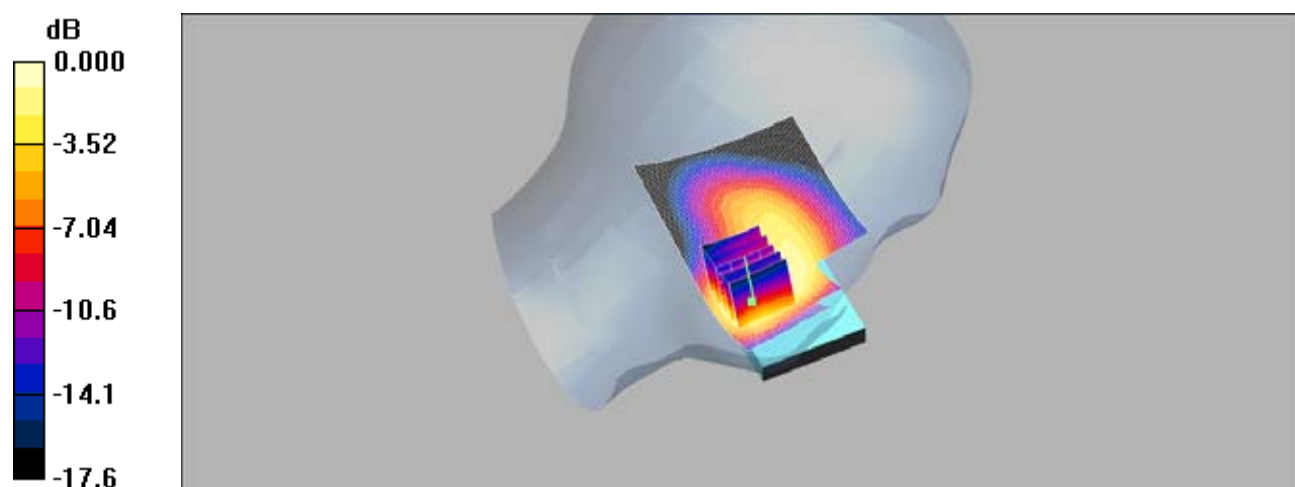

0 dB = 0.717mW/g

Date/Time: 2008/11/26 08:52:36

Le Cheek_CH810_repeated with WLAN802.11 b active

DUT: SAPP100;

Communication System: GSM1900; Frequency: 1909.8 MHz; Duty Cycle: 1:8.3

Medium: Head 1900 MHz Medium parameters used: $f = 1910$ MHz; $\sigma = 1.45$ mho/m; $\epsilon_r = 41.2$; $\rho = 1000$ kg/m³

Phantom section: Left Section

DASY4 Configuration:

- Probe: EX3DV3 - SN3526; ConvF(9.46, 9.46, 9.46); Calibrated: 2008/8/26
- Sensor-Surface: 4mm (Mechanical Surface Detection)
- Electronics: DAE4 Sn547; Calibrated: 2008/1/24
- Phantom: SAM1; Type: SAM 4.0; Serial: TP:1419
- Measurement SW: DASY4, V4.7 Build 71; Postprocessing SW: SEMCAD, V1.8 Build 184

LE Cheek/Area Scan (61x91x1): Measurement grid: dx=15mm, dy=15mm

Maximum value of SAR (interpolated) = 0.750 mW/g

LE Cheek/Zoom Scan (5x5x7)/Cube 0: Measurement grid: dx=8mm, dy=8mm, dz=5mm

Reference Value = 11.9 V/m; Power Drift = -0.121 dB

Peak SAR (extrapolated) = 1.07 W/kg

SAR(1 g) = 0.640 mW/g; SAR(10 g) = 0.382 mW/g

Maximum value of SAR (measured) = 0.695 mW/g

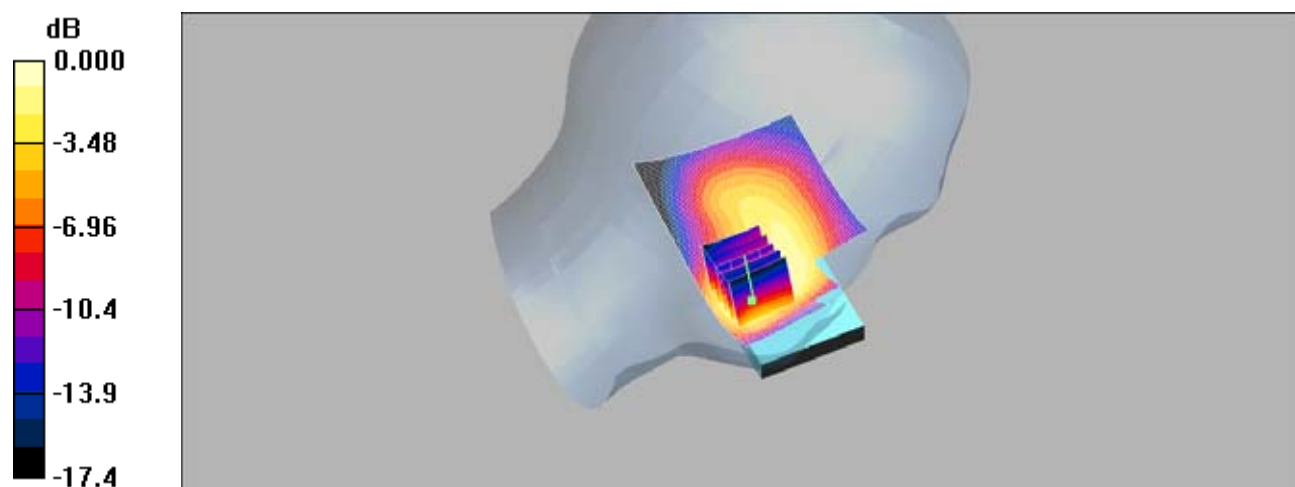

0 dB = 0.695mW/g

Date/Time: 2008/11/26 09:33:32

Le Cheek_CH810_repeated with WLAN802.11 g active

DUT: SAPP100;

Communication System: GSM1900; Frequency: 1909.8 MHz; Duty Cycle: 1:8.3

Medium: Head 1900 MHz Medium parameters used: $f = 1910$ MHz; $\sigma = 1.45$ mho/m; $\epsilon_r = 41.2$; $\rho = 1000$ kg/m³

Phantom section: Left Section

DASY4 Configuration:

- Probe: EX3DV3 - SN3526; ConvF(9.46, 9.46, 9.46); Calibrated: 2008/8/26
- Sensor-Surface: 4mm (Mechanical Surface Detection)
- Electronics: DAE4 Sn547; Calibrated: 2008/1/24
- Phantom: SAM1; Type: SAM 4.0; Serial: TP:1419
- Measurement SW: DASY4, V4.7 Build 71; Postprocessing SW: SEMCAD, V1.8 Build 184

LE Cheek/Area Scan (61x91x1): Measurement grid: dx=15mm, dy=15mm

Maximum value of SAR (interpolated) = 0.685 mW/g

LE Cheek/Zoom Scan (5x5x7)/Cube 0: Measurement grid: dx=8mm, dy=8mm, dz=5mm

Reference Value = 10.1 V/m; Power Drift = -0.018 dB

Peak SAR (extrapolated) = 1.04 W/kg

SAR(1 g) = 0.622 mW/g; SAR(10 g) = 0.376 mW/g

Maximum value of SAR (measured) = 0.674 mW/g

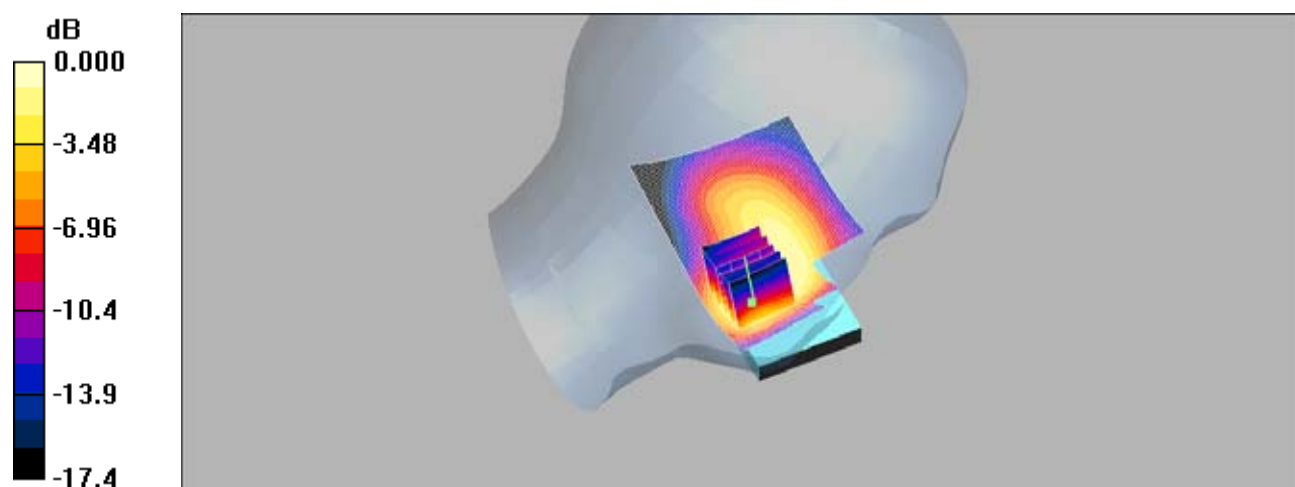

0 dB = 0.674mW/g

Date/Time: 2008/11/26 10:12:43

Le Cheek_CH810_repeated with Bluetooth & WLAN802.11 b active

DUT: SAPP100;

Communication System: GSM1900; Frequency: 1909.8 MHz; Duty Cycle: 1:8.3

Medium: Head 1900 MHz Medium parameters used: $f = 1910$ MHz; $\sigma = 1.45$ mho/m; $\epsilon_r = 41.2$; $\rho = 1000$ kg/m³

Phantom section: Left Section

DASY4 Configuration:

- Probe: EX3DV3 - SN3526; ConvF(9.46, 9.46, 9.46); Calibrated: 2008/8/26
- Sensor-Surface: 4mm (Mechanical Surface Detection)
- Electronics: DAE4 Sn547; Calibrated: 2008/1/24
- Phantom: SAM1; Type: SAM 4.0; Serial: TP:1419
- Measurement SW: DASY4, V4.7 Build 71; Postprocessing SW: SEMCAD, V1.8 Build 184

LE Cheek/Area Scan (61x91x1): Measurement grid: dx=15mm, dy=15mm

Maximum value of SAR (interpolated) = 0.688 mW/g

LE Cheek/Zoom Scan (5x5x7)/Cube 0: Measurement grid: dx=8mm, dy=8mm, dz=5mm

Reference Value = 10.2 V/m; Power Drift = -0.077 dB

Peak SAR (extrapolated) = 1.04 W/kg

SAR(1 g) = 0.630 mW/g; SAR(10 g) = 0.381 mW/g

Maximum value of SAR (measured) = 0.679 mW/g

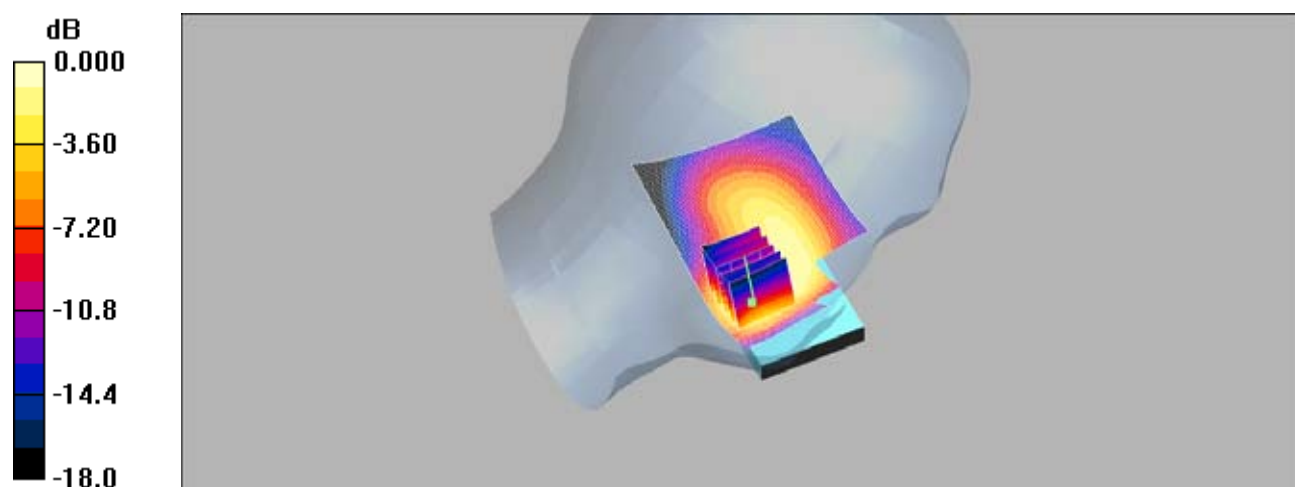

Date/Time: 2008/11/26 10:49:56

Le Cheek_CH810_repeated with WELLDONE Battery

DUT: SAPP100;

Communication System: GSM1900; Frequency: 1909.8 MHz; Duty Cycle: 1:8.3

Medium: Head 1900 MHz Medium parameters used: $f = 1910$ MHz; $\sigma = 1.45$ mho/m; $\epsilon_r = 41.2$; $\rho = 1000$ kg/m³

Phantom section: Left Section

DASY4 Configuration:

- Probe: EX3DV3 - SN3526; ConvF(9.46, 9.46, 9.46); Calibrated: 2008/8/26
- Sensor-Surface: 4mm (Mechanical Surface Detection)
- Electronics: DAE4 Sn547; Calibrated: 2008/1/24
- Phantom: SAM1; Type: SAM 4.0; Serial: TP:1419
- Measurement SW: DASY4, V4.7 Build 71; Postprocessing SW: SEMCAD, V1.8 Build 184

LE Cheek/Area Scan (61x91x1): Measurement grid: dx=15mm, dy=15mm

Maximum value of SAR (interpolated) = 0.787 mW/g

LE Cheek/Zoom Scan (5x5x7)/Cube 0: Measurement grid: dx=8mm, dy=8mm, dz=5mm

Reference Value = 8.09 V/m; Power Drift = -0.128 dB

Peak SAR (extrapolated) = 1.12 W/kg

SAR(1 g) = 0.665 mW/g; SAR(10 g) = 0.399 mW/g

Maximum value of SAR (measured) = 0.725 mW/g

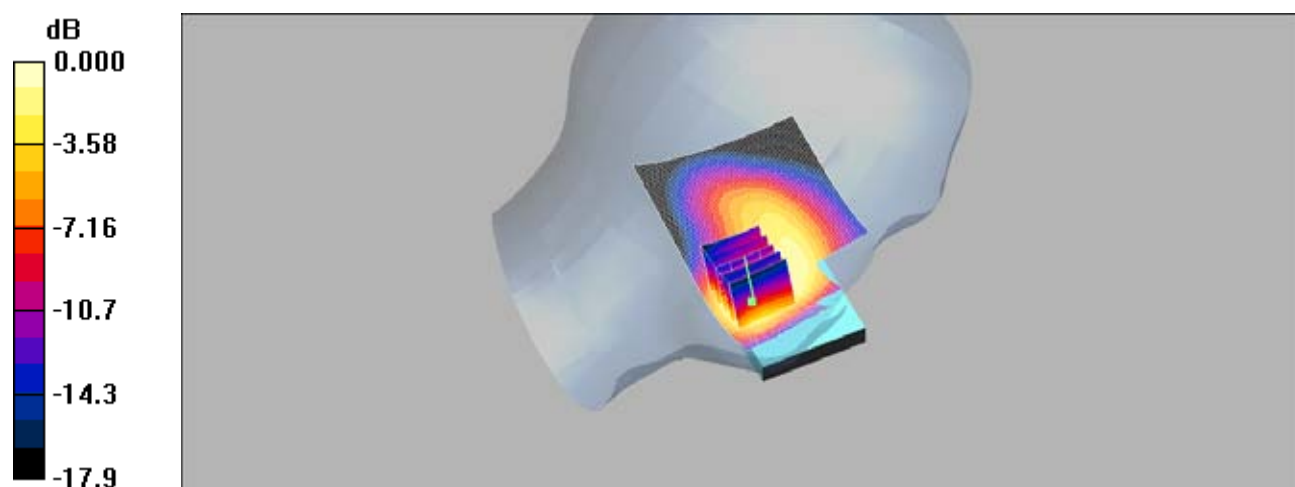

0 dB = 0.725mW/g

Date/Time: 2008/11/26 13:18:11

BODY_CH512

DUT: SAPP100;

Communication System: GSM1900; Frequency: 1850.2 MHz; Duty Cycle: 1:2
Medium: M1800 & 1900 Medium parameters used (interpolated): $f = 1850.2$ MHz; $\sigma = 1.54$ mho/m; $\epsilon_r = 51.4$; $\rho = 1000$ kg/m³
Phantom section: Flat Section

DASY4 Configuration:

- Probe: EX3DV3 - SN3526; ConvF(9.28, 9.28, 9.28); Calibrated: 2008/8/26
- Sensor-Surface: 4mm (Mechanical Surface Detection)
- Electronics: DAE4 Sn547; Calibrated: 2008/1/24
- Phantom: SAM1; Type: SAM 4.0; Serial: TP:1419
- Measurement SW: DASY4, V4.7 Build 71; Postprocessing SW: SEMCAD, V1.8 Build 184

BODY/Area Scan (51x91x1): Measurement grid: dx=15mm, dy=15mm

Maximum value of SAR (interpolated) = 1.05 mW/g

BODY/Zoom Scan (5x5x7)/Cube 0: Measurement grid: dx=8mm, dy=8mm, dz=5mm

Reference Value = 13.4 V/m; Power Drift = -0.028 dB

Peak SAR (extrapolated) = 1.56 W/kg

SAR(1 g) = 0.934 mW/g; SAR(10 g) = 0.539 mW/g

Maximum value of SAR (measured) = 1.02 mW/g

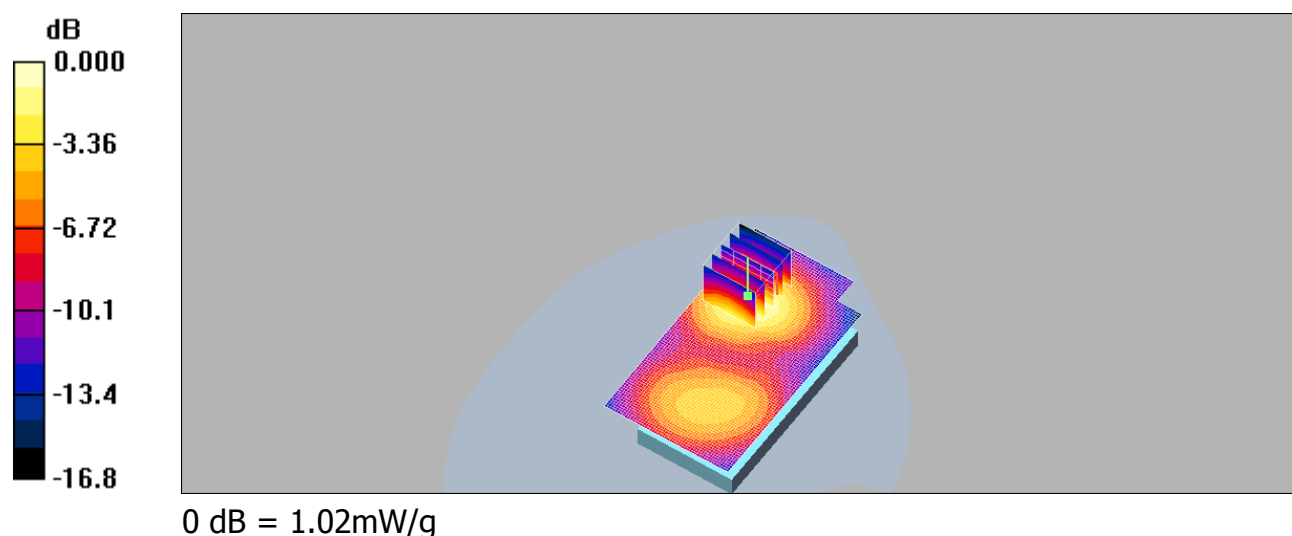

Date/Time: 2008/11/26 13:43:46

BODY_CH661

DUT: SAPP100;

Communication System: GSM1900; Frequency: 1880 MHz; Duty Cycle: 1:2

Medium: M1800 & 1900 Medium parameters used: $f = 1880$ MHz; $\sigma = 1.56$ mho/m; $\epsilon_r = 51.3$;
 $\rho = 1000$ kg/m³

Phantom section: Flat Section

DASY4 Configuration:

- Probe: EX3DV3 - SN3526; ConvF(9.28, 9.28, 9.28); Calibrated: 2008/8/26
- Sensor-Surface: 4mm (Mechanical Surface Detection)
- Electronics: DAE4 Sn547; Calibrated: 2008/1/24
- Phantom: SAM1; Type: SAM 4.0; Serial: TP:1419
- Measurement SW: DASY4, V4.7 Build 71; Postprocessing SW: SEMCAD, V1.8 Build 184

BODY/Area Scan (51x91x1): Measurement grid: dx=15mm, dy=15mm

Maximum value of SAR (interpolated) = 0.929 mW/g

BODY/Zoom Scan (5x5x7)/Cube 0: Measurement grid: dx=8mm, dy=8mm,
dz=5mm

Reference Value = 12.7 V/m; Power Drift = -0.076 dB

Peak SAR (extrapolated) = 1.38 W/kg

SAR(1 g) = 0.830 mW/g; SAR(10 g) = 0.479 mW/g

Maximum value of SAR (measured) = 0.888 mW/g

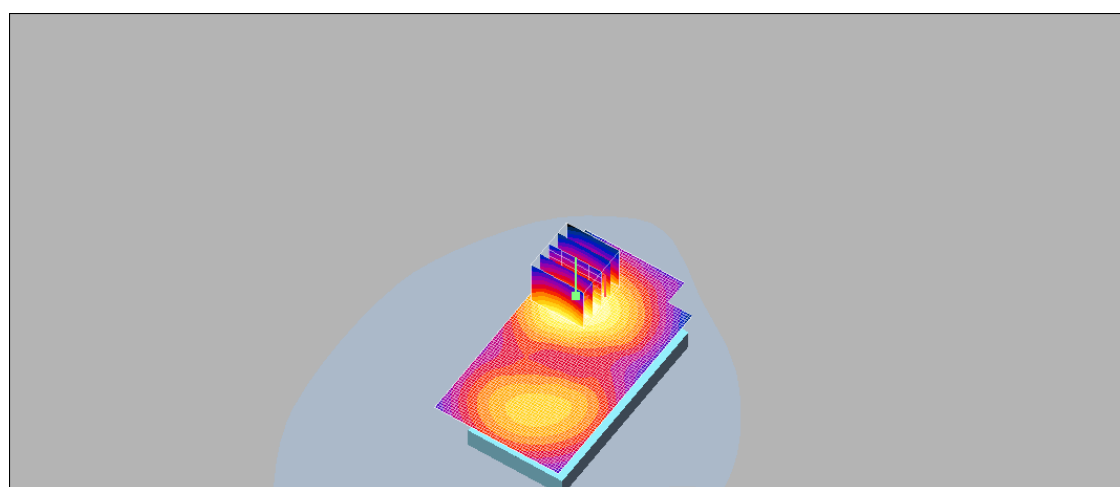
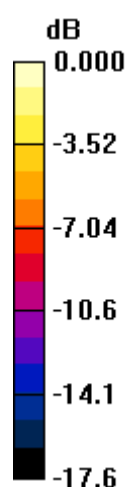

0 dB = 0.888mW/g

Date/Time: 2008/11/26 14:16:32

BODY_CH810

DUT: SAPP100;

Communication System: GSM1900; Frequency: 1909.8 MHz; Duty Cycle: 1:2
Medium: M1800 & 1900 Medium parameters used: $f = 1910$ MHz; $\sigma = 1.58$ mho/m; $\epsilon_r = 51.1$;
 $\rho = 1000$ kg/m³
Phantom section: Flat Section

DASY4 Configuration:

- Probe: EX3DV3 - SN3526; ConvF(9.28, 9.28, 9.28); Calibrated: 2008/8/26
- Sensor-Surface: 4mm (Mechanical Surface Detection)
- Electronics: DAE4 Sn547; Calibrated: 2008/1/24
- Phantom: SAM1; Type: SAM 4.0; Serial: TP:1419
- Measurement SW: DASY4, V4.7 Build 71; Postprocessing SW: SEMCAD, V1.8 Build 184

BODY/Area Scan (51x91x1): Measurement grid: dx=15mm, dy=15mm

Maximum value of SAR (interpolated) = 0.915 mW/g

BODY/Zoom Scan (5x5x7)/Cube 0: Measurement grid: dx=8mm, dy=8mm,
dz=5mm

Reference Value = 12.1 V/m; Power Drift = -0.019 dB

Peak SAR (extrapolated) = 1.37 W/kg

SAR(1 g) = 0.825 mW/g; SAR(10 g) = 0.475 mW/g

Maximum value of SAR (measured) = 0.892 mW/g

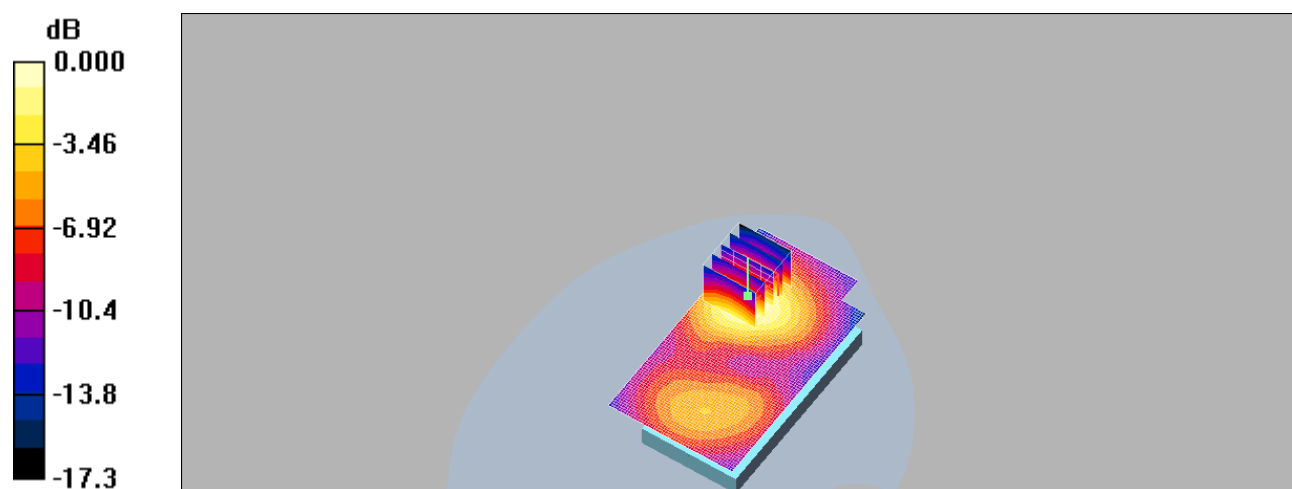

Date/Time: 2008/11/26 14:42:14

BODY_CH512_ repeated for EUT front to phantom

DUT: SAPP100;

Communication System: GSM1900; Frequency: 1850.2 MHz; Duty Cycle: 1:2
Medium: M1800 & 1900 Medium parameters used (interpolated): $f = 1850.2$ MHz; $\sigma = 1.54$ mho/m; $\epsilon_r = 51.4$; $\rho = 1000$ kg/m³
Phantom section: Flat Section

DASY4 Configuration:

- Probe: EX3DV3 - SN3526; ConvF(9.28, 9.28, 9.28); Calibrated: 2008/8/26
- Sensor-Surface: 4mm (Mechanical Surface Detection)
- Electronics: DAE4 Sn547; Calibrated: 2008/1/24
- Phantom: SAM1; Type: SAM 4.0; Serial: TP:1419
- Measurement SW: DASY4, V4.7 Build 71; Postprocessing SW: SEMCAD, V1.8 Build 184

BODY/Area Scan (51x91x1): Measurement grid: dx=15mm, dy=15mm

Maximum value of SAR (interpolated) = 0.535 mW/g

BODY/Zoom Scan (5x5x7)/Cube 0: Measurement grid: dx=8mm, dy=8mm, dz=5mm

Reference Value = 12.3 V/m; Power Drift = -0.063 dB

Peak SAR (extrapolated) = 0.771 W/kg

SAR(1 g) = 0.471 mW/g; SAR(10 g) = 0.280 mW/g

Maximum value of SAR (measured) = 0.514 mW/g

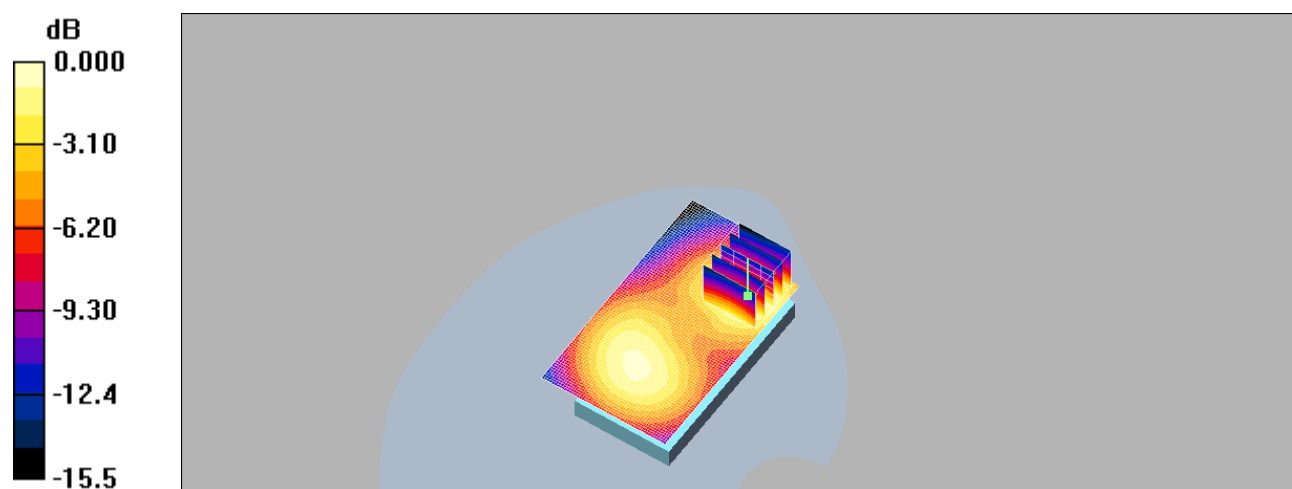

0 dB = 0.514mW/g

Date/Time: 2008/11/26 15:19:11

BODY_CH512_repeated with Memory card

DUT: SAPP100;

Communication System: GSM1900; Frequency: 1850.2 MHz; Duty Cycle: 1:2
Medium: M1800 & 1900 Medium parameters used (interpolated): $f = 1850.2$ MHz; $\sigma = 1.54$ mho/m; $\epsilon_r = 51.4$; $\rho = 1000$ kg/m³
Phantom section: Flat Section

DASY4 Configuration:

- Probe: EX3DV3 - SN3526; ConvF(9.28, 9.28, 9.28); Calibrated: 2008/8/26
- Sensor-Surface: 4mm (Mechanical Surface Detection)
- Electronics: DAE4 Sn547; Calibrated: 2008/1/24
- Phantom: SAM1; Type: SAM 4.0; Serial: TP:1419
- Measurement SW: DASY4, V4.7 Build 71; Postprocessing SW: SEMCAD, V1.8 Build 184

BODY/Area Scan (51x91x1): Measurement grid: dx=15mm, dy=15mm

Maximum value of SAR (interpolated) = 0.957 mW/g

BODY/Zoom Scan (5x5x7)/Cube 0: Measurement grid: dx=8mm, dy=8mm, dz=5mm

Reference Value = 12.0 V/m; Power Drift = 0.026 dB

Peak SAR (extrapolated) = 1.48 W/kg

SAR(1 g) = 0.863 mW/g; SAR(10 g) = 0.488 mW/g

Maximum value of SAR (measured) = 0.947 mW/g

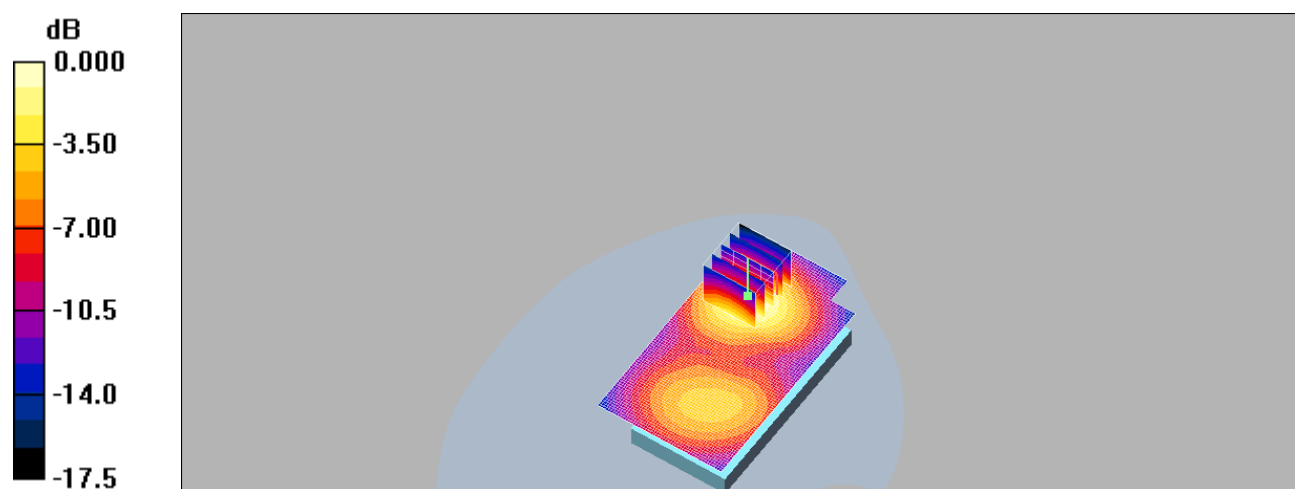

Date/Time: 2008/11/26 15:55:56

BODY_CH512_repeated with Bluetooth active

DUT: SAPP100;

Communication System: GSM1900; Frequency: 1850.2 MHz; Duty Cycle: 1:2
Medium: M1800 & 1900 Medium parameters used (interpolated): $f = 1850.2$ MHz; $\sigma = 1.54$ mho/m; $\epsilon_r = 51.4$; $\rho = 1000$ kg/m³
Phantom section: Flat Section

DASY4 Configuration:

- Probe: EX3DV3 - SN3526; ConvF(9.28, 9.28, 9.28); Calibrated: 2008/8/26
- Sensor-Surface: 4mm (Mechanical Surface Detection)
- Electronics: DAE4 Sn547; Calibrated: 2008/1/24
- Phantom: SAM1; Type: SAM 4.0; Serial: TP:1419
- Measurement SW: DASY4, V4.7 Build 71; Postprocessing SW: SEMCAD, V1.8 Build 184

BODY/Area Scan (51x91x1): Measurement grid: dx=15mm, dy=15mm

Maximum value of SAR (interpolated) = 0.942 mW/g

BODY/Zoom Scan (5x5x7)/Cube 0: Measurement grid: dx=8mm, dy=8mm, dz=5mm

Reference Value = 11.9 V/m; Power Drift = -0.041 dB

Peak SAR (extrapolated) = 1.44 W/kg

SAR(1 g) = 0.841 mW/g; SAR(10 g) = 0.477 mW/g

Maximum value of SAR (measured) = 0.929 mW/g

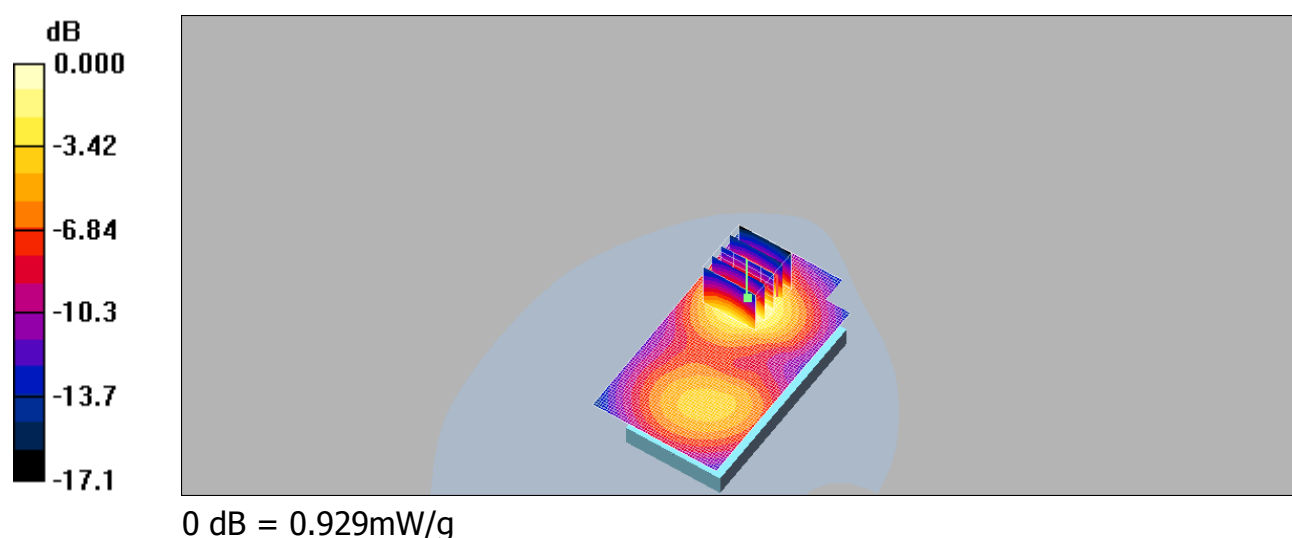

Date/Time: 2008/11/26 16:29:55

BODY_CH512_repeated with WLAN802.11 b active

DUT: SAPP100;

Communication System: GSM1900; Frequency: 1850.2 MHz; Duty Cycle: 1:2
Medium: M1800 & 1900 Medium parameters used (interpolated): $f = 1850.2$ MHz; $\sigma = 1.54$ mho/m; $\epsilon_r = 51.4$; $\rho = 1000$ kg/m³
Phantom section: Flat Section

DASY4 Configuration:

- Probe: EX3DV3 - SN3526; ConvF(9.28, 9.28, 9.28); Calibrated: 2008/8/26
- Sensor-Surface: 4mm (Mechanical Surface Detection)
- Electronics: DAE4 Sn547; Calibrated: 2008/1/24
- Phantom: SAM1; Type: SAM 4.0; Serial: TP:1419
- Measurement SW: DASY4, V4.7 Build 71; Postprocessing SW: SEMCAD, V1.8 Build 184

BODY/Area Scan (51x91x1): Measurement grid: dx=15mm, dy=15mm

Maximum value of SAR (interpolated) = 1.11 mW/g

BODY/Zoom Scan (5x5x7)/Cube 0: Measurement grid: dx=8mm, dy=8mm, dz=5mm

Reference Value = 14.5 V/m; Power Drift = -0.108 dB

Peak SAR (extrapolated) = 1.63 W/kg

SAR(1 g) = 0.968 mW/g; SAR(10 g) = 0.550 mW/g

Maximum value of SAR (measured) = 1.06 mW/g

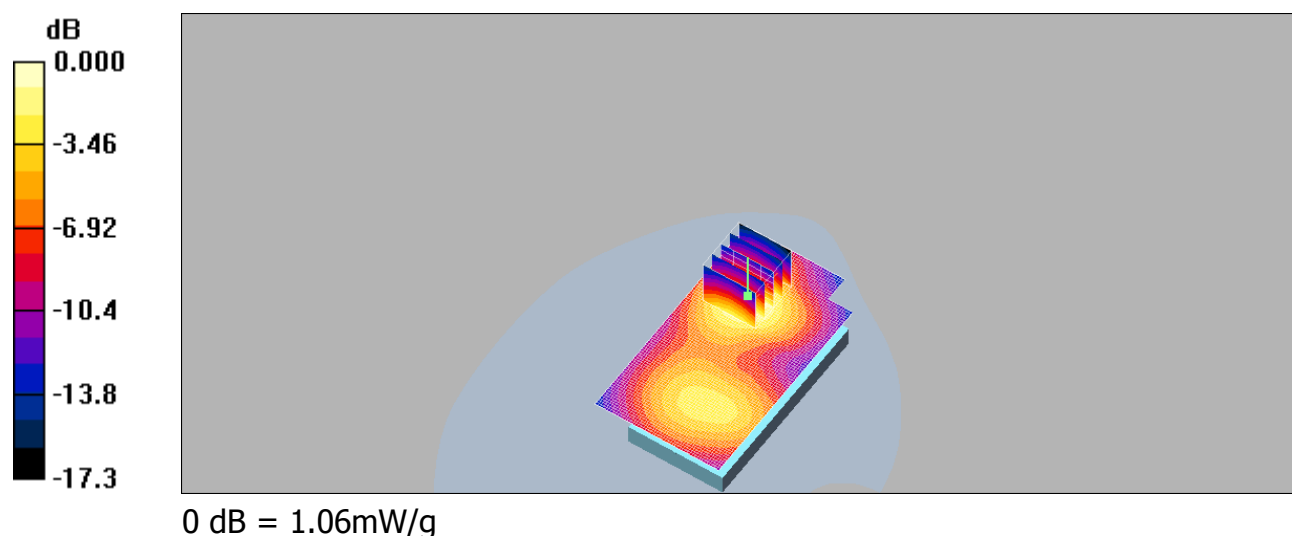

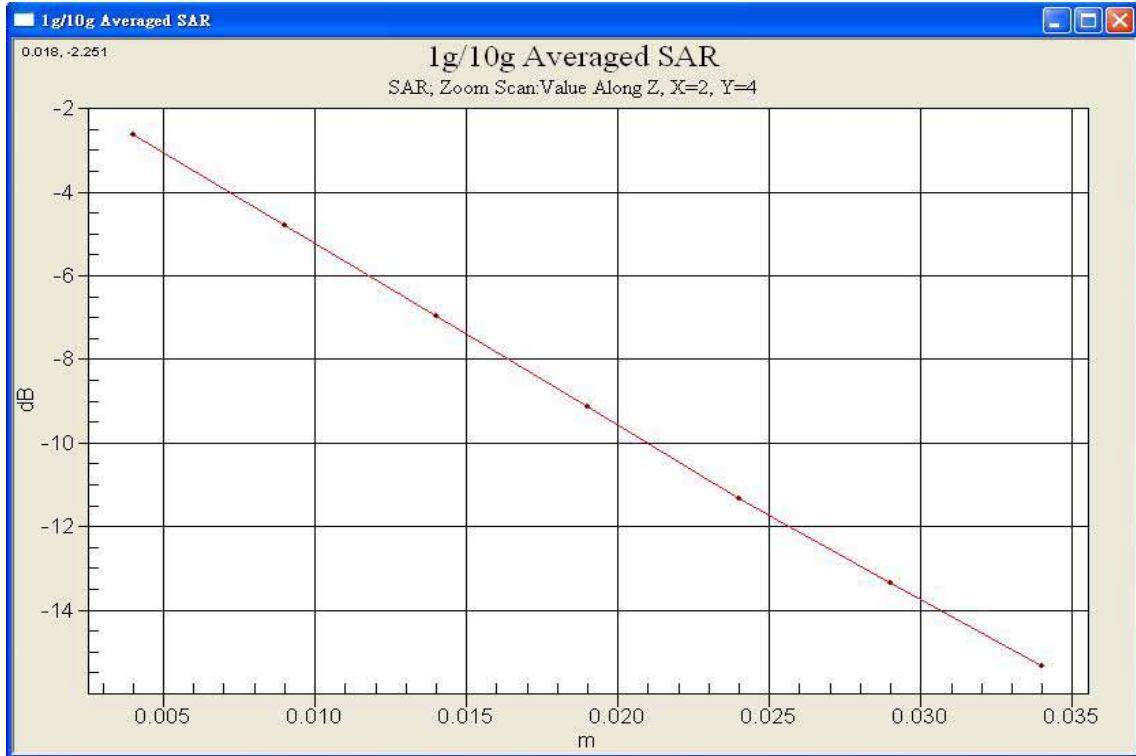

Date/Time: 2008/11/26 17:01:46

BODY_CH512_ repeated with WLAN802.11 g active

DUT: SAPP100;

Communication System: GSM1900; Frequency: 1850.2 MHz; Duty Cycle: 1:2
Medium: M1800 & 1900 Medium parameters used (interpolated): $f = 1850.2$ MHz; $\sigma = 1.54$ mho/m; $\epsilon_r = 51.4$; $\rho = 1000$ kg/m³
Phantom section: Flat Section

DASY4 Configuration:

- Probe: EX3DV3 - SN3526; ConvF(9.28, 9.28, 9.28); Calibrated: 2008/8/26
- Sensor-Surface: 4mm (Mechanical Surface Detection)
- Electronics: DAE4 Sn547; Calibrated: 2008/1/24
- Phantom: SAM1; Type: SAM 4.0; Serial: TP:1419
- Measurement SW: DASY4, V4.7 Build 71; Postprocessing SW: SEMCAD, V1.8 Build 184

BODY/Area Scan (51x91x1): Measurement grid: dx=15mm, dy=15mm

Maximum value of SAR (interpolated) = 1.05 mW/g

BODY/Zoom Scan (5x5x7)/Cube 0: Measurement grid: dx=8mm, dy=8mm, dz=5mm

Reference Value = 12.9 V/m; Power Drift = -0.140 dB

Peak SAR (extrapolated) = 1.56 W/kg

SAR(1 g) = 0.925 mW/g; SAR(10 g) = 0.527 mW/g

Maximum value of SAR (measured) = 1.02 mW/g

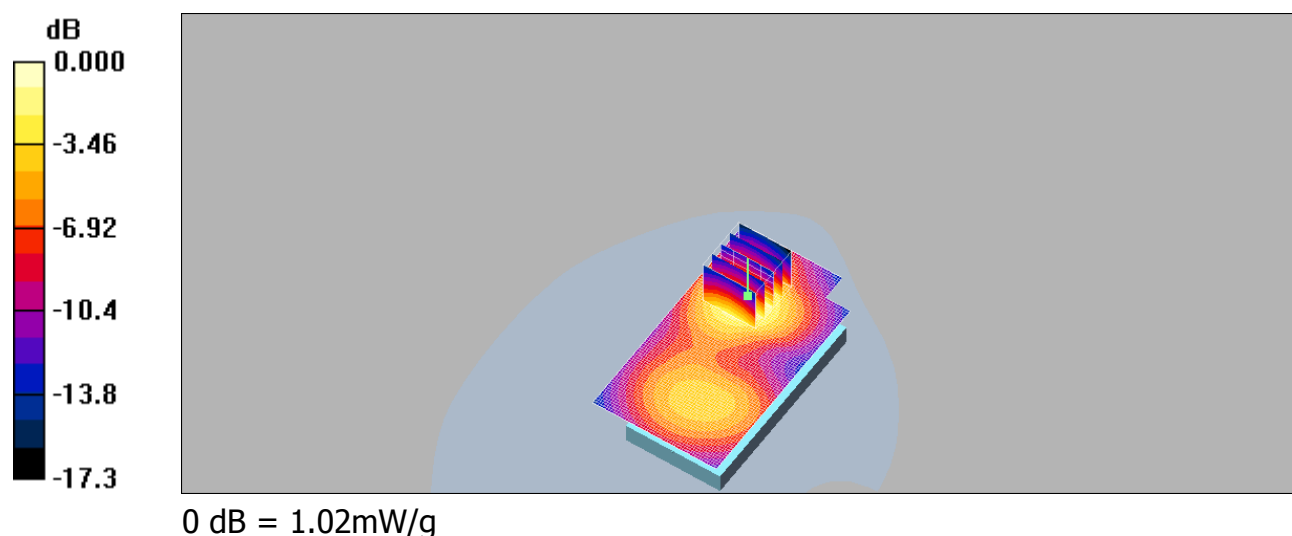

Date/Time: 2008/11/26 17:42:33

BODY_CH512_ repeated with Bluetooth & WLAN802.11 b active

DUT: SAPP100;

Communication System: GSM1900; Frequency: 1850.2 MHz; Duty Cycle: 1:2
Medium: M1800 & 1900 Medium parameters used (interpolated): $f = 1850.2$ MHz; $\sigma = 1.54$ mho/m; $\epsilon_r = 51.4$; $\rho = 1000$ kg/m³
Phantom section: Flat Section

DASY4 Configuration:

- Probe: EX3DV3 - SN3526; ConvF(9.28, 9.28, 9.28); Calibrated: 2008/8/26
- Sensor-Surface: 4mm (Mechanical Surface Detection)
- Electronics: DAE4 Sn547; Calibrated: 2008/1/24
- Phantom: SAM1; Type: SAM 4.0; Serial: TP:1419
- Measurement SW: DASY4, V4.7 Build 71; Postprocessing SW: SEMCAD, V1.8 Build 184

BODY/Area Scan (51x91x1): Measurement grid: dx=15mm, dy=15mm

Maximum value of SAR (interpolated) = 1.02 mW/g

BODY/Zoom Scan (5x5x7)/Cube 0: Measurement grid: dx=8mm, dy=8mm, dz=5mm

Reference Value = 12.6 V/m; Power Drift = -0.047 dB

Peak SAR (extrapolated) = 1.50 W/kg

SAR(1 g) = 0.906 mW/g; SAR(10 g) = 0.518 mW/g

Maximum value of SAR (measured) = 0.995 mW/g

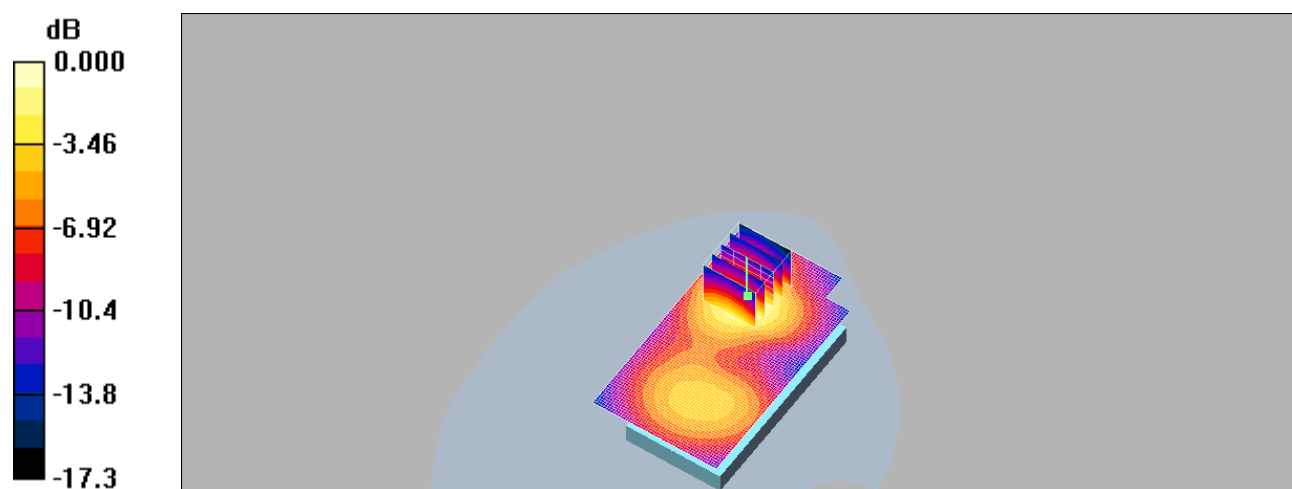

Date/Time: 2008/11/26 18:38:34

BODY_CH512_repeated with WELLDONE Battery

DUT: SAPP100;

Communication System: GSM1900; Frequency: 1850.2 MHz; Duty Cycle: 1:2
Medium: M1800 & 1900 Medium parameters used (interpolated): $f = 1850.2$ MHz; $\sigma = 1.54$ mho/m; $\epsilon_r = 51.4$; $\rho = 1000$ kg/m³
Phantom section: Flat Section

DASY4 Configuration:

- Probe: EX3DV3 - SN3526; ConvF(9.28, 9.28, 9.28); Calibrated: 2008/8/26
- Sensor-Surface: 4mm (Mechanical Surface Detection)
- Electronics: DAE4 Sn547; Calibrated: 2008/1/24
- Phantom: SAM1; Type: SAM 4.0; Serial: TP:1419
- Measurement SW: DASY4, V4.7 Build 71; Postprocessing SW: SEMCAD, V1.8 Build 184

BODY/Area Scan (51x91x1): Measurement grid: dx=15mm, dy=15mm

Maximum value of SAR (interpolated) = 1.03 mW/g

BODY/Zoom Scan (5x5x7)/Cube 0: Measurement grid: dx=8mm, dy=8mm, dz=5mm

Reference Value = 12.5 V/m; Power Drift = -0.031 dB

Peak SAR (extrapolated) = 1.54 W/kg

SAR(1 g) = 0.908 mW/g; SAR(10 g) = 0.514 mW/g

Maximum value of SAR (measured) = 0.996 mW/g

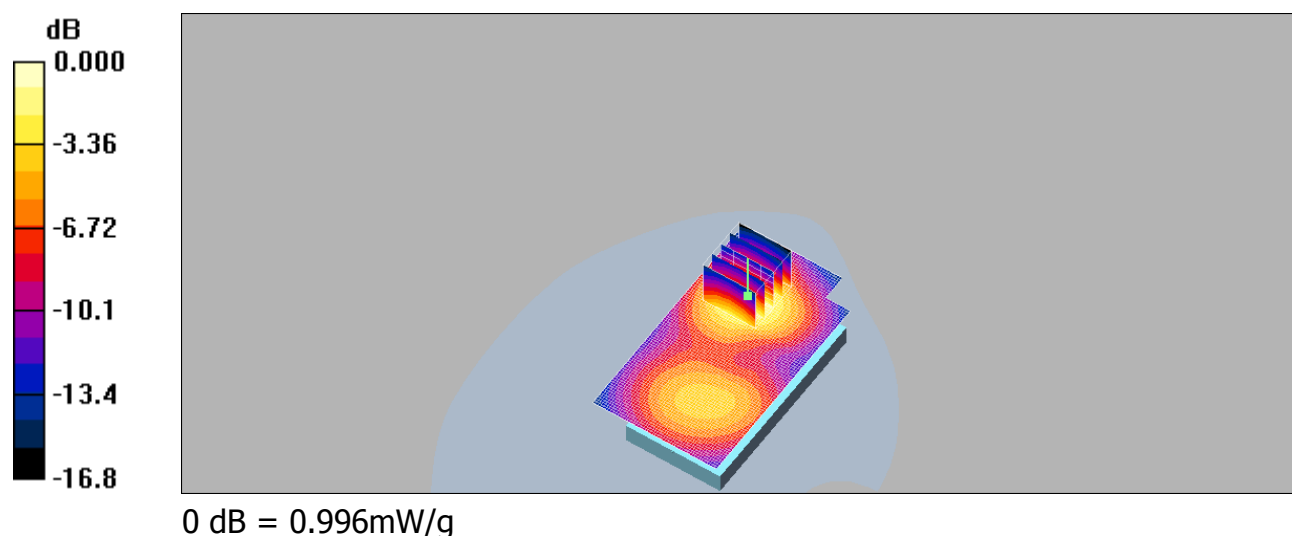

Date/Time: 2008/11/25 13:38:55

BODY_WLAN802.11 b_CH1

DUT: SAPP100;

Communication System: Wireless LAN; Frequency: 2412 MHz; Duty Cycle: 1:1
Medium: Muscle 2450 Medium parameters used: $f = 2412$ MHz; $\sigma = 1.9$ mho/m; $\epsilon_r = 52.8$; $\rho = 1000$ kg/m³
Phantom section: Flat Section

DASY4 Configuration:

- Probe: EX3DV3 - SN3526; ConvF(8.18, 8.18, 8.18); Calibrated: 2008/8/26
- Sensor-Surface: 4mm (Mechanical Surface Detection)
- Electronics: DAE4 Sn547; Calibrated: 2008/1/24
- Phantom: SAM1; Type: SAM 4.0; Serial: TP:1419
- Measurement SW: DASY4, V4.7 Build 71; Postprocessing SW: SEMCAD, V1.8 Build 184

BODY/Area Scan (51x91x1): Measurement grid: dx=15mm, dy=15mm

Maximum value of SAR (interpolated) = 0.209 mW/g

BODY/Zoom Scan (5x5x7)/Cube 0: Measurement grid: dx=8mm, dy=8mm, dz=5mm

Reference Value = 6.77 V/m; Power Drift = 0.044 dB

Peak SAR (extrapolated) = 0.366 W/kg

SAR(1 g) = 0.186 mW/g; SAR(10 g) = 0.091 mW/g

Maximum value of SAR (measured) = 0.214 mW/g

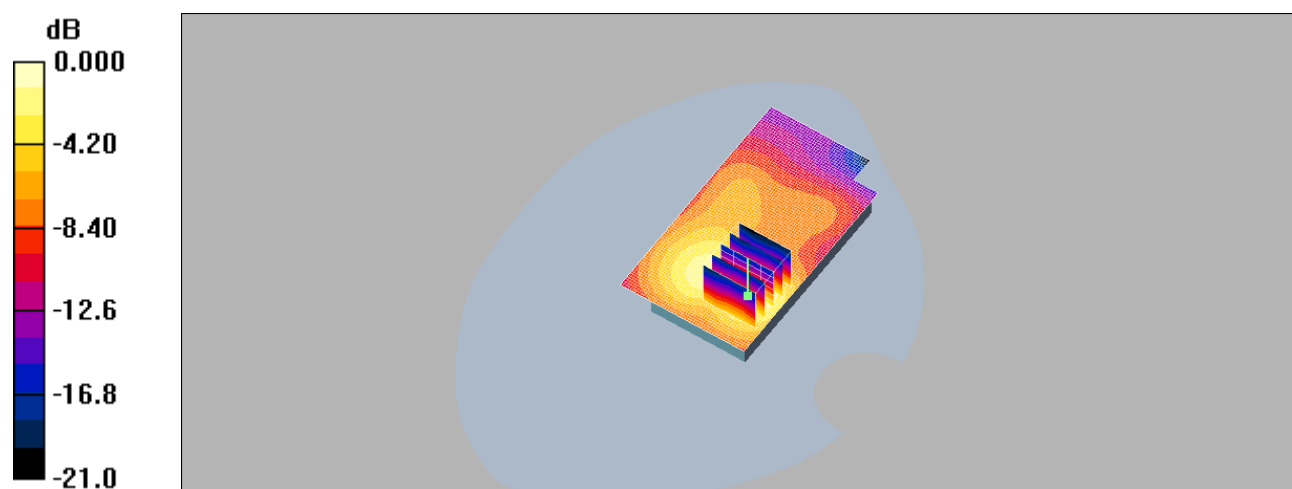

0 dB = 0.214mW/g

Date/Time: 2008/11/25 14:05:32

BODY_WLAN802.11 b_CH6

DUT: SAPP100;

Communication System: Wireless LAN; Frequency: 2437 MHz; Duty Cycle: 1:1
Medium: Muscle 2450 Medium parameters used: $f = 2437$ MHz; $\sigma = 1.92$ mho/m; $\epsilon_r = 52.7$;
 $\rho = 1000$ kg/m³
Phantom section: Flat Section

DASY4 Configuration:

- Probe: EX3DV3 - SN3526; ConvF(8.18, 8.18, 8.18); Calibrated: 2008/8/26
- Sensor-Surface: 4mm (Mechanical Surface Detection)
- Electronics: DAE4 Sn547; Calibrated: 2008/1/24
- Phantom: SAM1; Type: SAM 4.0; Serial: TP:1419
- Measurement SW: DASY4, V4.7 Build 71; Postprocessing SW: SEMCAD, V1.8 Build 184

BODY/Area Scan (51x91x1): Measurement grid: dx=15mm, dy=15mm

Maximum value of SAR (interpolated) = 0.256 mW/g

BODY/Zoom Scan (5x5x7)/Cube 0: Measurement grid: dx=8mm, dy=8mm,
dz=5mm

Reference Value = 8.01 V/m; Power Drift = 0.005 dB

Peak SAR (extrapolated) = 0.447 W/kg

SAR(1 g) = 0.225 mW/g; SAR(10 g) = 0.111 mW/g

Maximum value of SAR (measured) = 0.255 mW/g

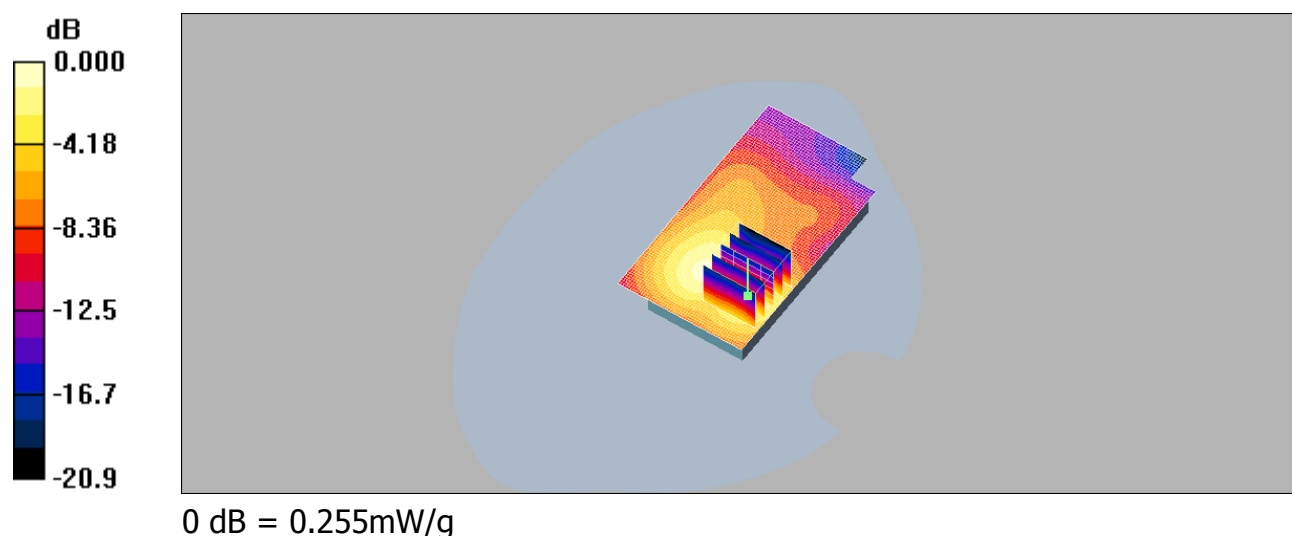

Date/Time: 2008/11/25 14:42:19

BODY_WLAN802.11 b_CH11

DUT: SAPP100;

Communication System: Wireless LAN; Frequency: 2462 MHz; Duty Cycle: 1:1
Medium: Muscle 2450 Medium parameters used: $f = 2462$ MHz; $\sigma = 1.96$ mho/m; $\epsilon_r = 52.6$;
 $\rho = 1000$ kg/m³
Phantom section: Flat Section

DASY4 Configuration:

- Probe: EX3DV3 - SN3526; ConvF(8.18, 8.18, 8.18); Calibrated: 2008/8/26
- Sensor-Surface: 4mm (Mechanical Surface Detection)
- Electronics: DAE4 Sn547; Calibrated: 2008/1/24
- Phantom: SAM1; Type: SAM 4.0; Serial: TP:1419
- Measurement SW: DASY4, V4.7 Build 71; Postprocessing SW: SEMCAD, V1.8 Build 184

BODY/Area Scan (51x91x1): Measurement grid: dx=15mm, dy=15mm

Maximum value of SAR (interpolated) = 0.264 mW/g

BODY/Zoom Scan (5x5x7)/Cube 0: Measurement grid: dx=8mm, dy=8mm, dz=5mm

Reference Value = 8.28 V/m; Power Drift = -0.045 dB

Peak SAR (extrapolated) = 0.475 W/kg

SAR(1 g) = 0.236 mW/g; SAR(10 g) = 0.114 mW/g

Maximum value of SAR (measured) = 0.267 mW/g

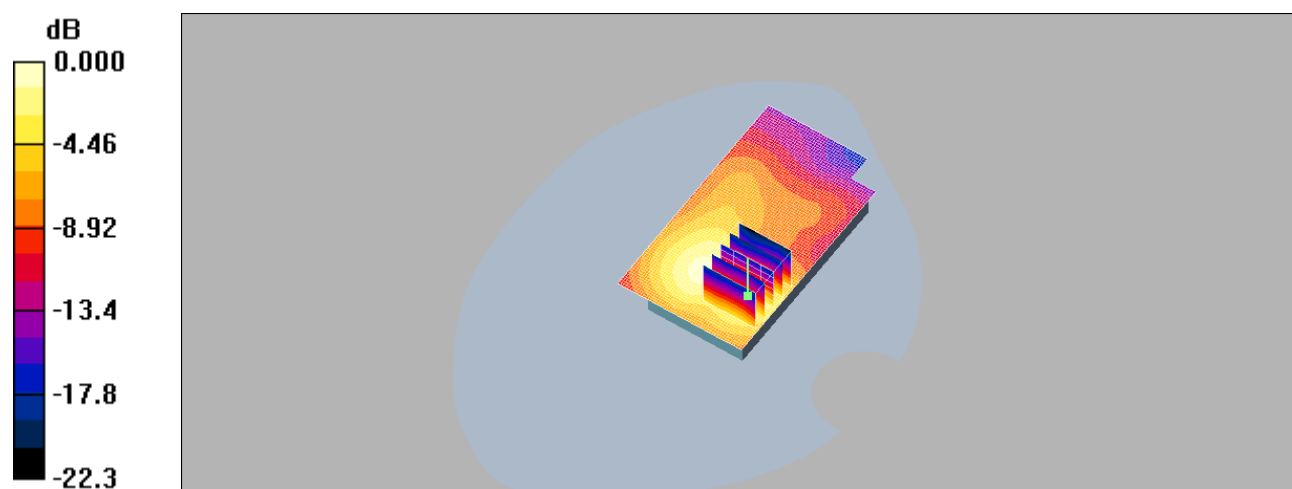

0 dB = 0.267mW/g

Date/Time: 2008/11/25 16:28:57

BODY_WLAN802.11 b_CH11_ repeated for EUT front to phantom

DUT: SAPP100;

Communication System: Wireless LAN; Frequency: 2462 MHz; Duty Cycle: 1:1
Medium: Muscle 2450 Medium parameters used: $f = 2462$ MHz; $\sigma = 1.96$ mho/m; $\epsilon_r = 52.6$;
 $\rho = 1000$ kg/m³
Phantom section: Flat Section

DASY4 Configuration:

- Probe: EX3DV3 - SN3526; ConvF(8.18, 8.18, 8.18); Calibrated: 2008/8/26
- Sensor-Surface: 4mm (Mechanical Surface Detection)
- Electronics: DAE4 Sn547; Calibrated: 2008/1/24
- Phantom: SAM1; Type: SAM 4.0; Serial: TP:1419
- Measurement SW: DASY4, V4.7 Build 71; Postprocessing SW: SEMCAD, V1.8 Build 184

BODY/Area Scan (51x91x1): Measurement grid: dx=15mm, dy=15mm

Maximum value of SAR (interpolated) = 0.068 mW/g

BODY/Zoom Scan (5x5x7)/Cube 0: Measurement grid: dx=8mm, dy=8mm, dz=5mm

Reference Value = 4.75 V/m; Power Drift = 0.052 dB

Peak SAR (extrapolated) = 0.104 W/kg

SAR(1 g) = 0.059 mW/g; SAR(10 g) = 0.033 mW/g

Maximum value of SAR (measured) = 0.064 mW/g

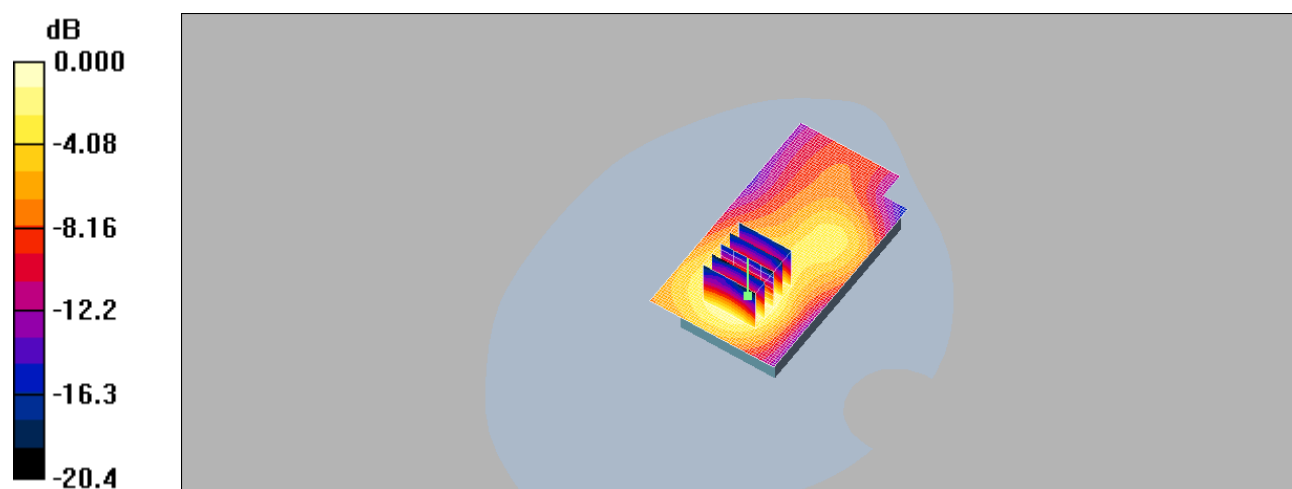

0 dB = 0.064mW/g

Date/Time: 2008/11/25 17:06:05

BODY_WLAN802.11 b_CH11_repeated with Memory card

DUT: SAPP100;

Communication System: Wireless LAN; Frequency: 2462 MHz; Duty Cycle: 1:1
Medium: Muscle 2450 Medium parameters used: $f = 2462$ MHz; $\sigma = 1.96$ mho/m; $\epsilon_r = 52.6$;
 $\rho = 1000$ kg/m³
Phantom section: Flat Section

DASY4 Configuration:

- Probe: EX3DV3 - SN3526; ConvF(8.18, 8.18, 8.18); Calibrated: 2008/8/26
- Sensor-Surface: 4mm (Mechanical Surface Detection)
- Electronics: DAE4 Sn547; Calibrated: 2008/1/24
- Phantom: SAM1; Type: SAM 4.0; Serial: TP:1419
- Measurement SW: DASY4, V4.7 Build 71; Postprocessing SW: SEMCAD, V1.8 Build 184

BODY/Area Scan (51x91x1): Measurement grid: dx=15mm, dy=15mm

Maximum value of SAR (interpolated) = 0.286 mW/g

BODY/Zoom Scan (5x5x7)/Cube 0: Measurement grid: dx=8mm, dy=8mm, dz=5mm

Reference Value = 8.17 V/m; Power Drift = -0.030 dB

Peak SAR (extrapolated) = 0.514 W/kg

SAR(1 g) = 0.256 mW/g; SAR(10 g) = 0.123 mW/g

Maximum value of SAR (measured) = 0.297 mW/g

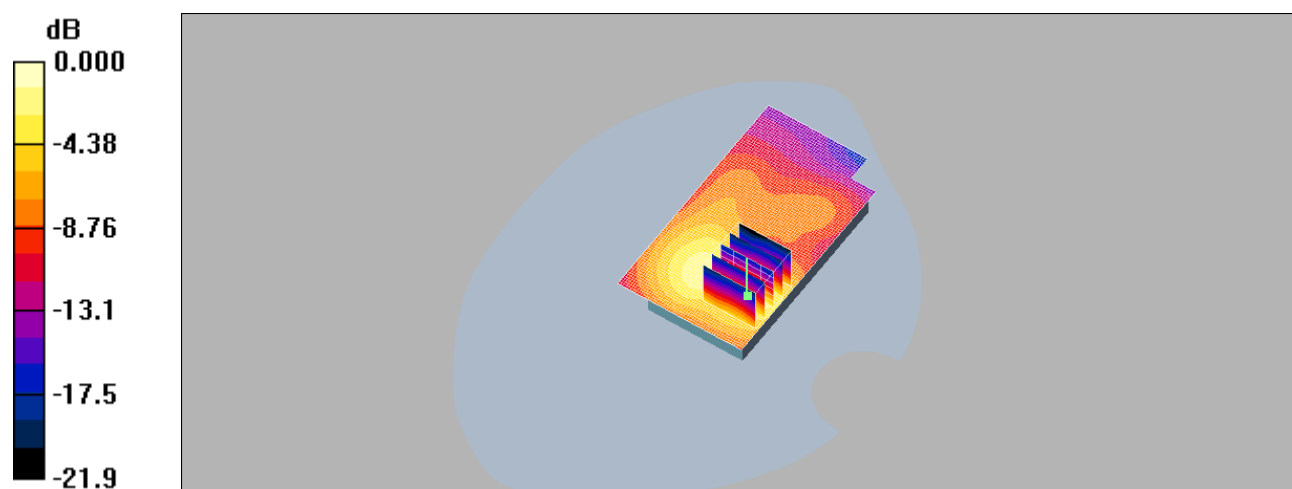

0 dB = 0.297mW/g

Date/Time: 2008/11/25 17:43:09

BODY_WLAN802.11 b_CH11_repeated with Bluetooth active

DUT: SAPP100;

Communication System: Wireless LAN; Frequency: 2462 MHz; Duty Cycle: 1:1
Medium: Muscle 2450 Medium parameters used: $f = 2462$ MHz; $\sigma = 1.96$ mho/m; $\epsilon_r = 52.6$;
 $\rho = 1000$ kg/m³
Phantom section: Flat Section

DASY4 Configuration:

- Probe: EX3DV3 - SN3526; ConvF(8.18, 8.18, 8.18); Calibrated: 2008/8/26
- Sensor-Surface: 4mm (Mechanical Surface Detection)
- Electronics: DAE4 Sn547; Calibrated: 2008/1/24
- Phantom: SAM1; Type: SAM 4.0; Serial: TP:1419
- Measurement SW: DASY4, V4.7 Build 71; Postprocessing SW: SEMCAD, V1.8 Build 184

BODY/Area Scan (51x91x1): Measurement grid: dx=15mm, dy=15mm

Maximum value of SAR (interpolated) = 0.294 mW/g

BODY/Zoom Scan (5x5x7)/Cube 0: Measurement grid: dx=8mm, dy=8mm, dz=5mm

Reference Value = 7.58 V/m; Power Drift = 0.033 dB

Peak SAR (extrapolated) = 0.517 W/kg

SAR(1 g) = 0.256 mW/g; SAR(10 g) = 0.122 mW/g

Maximum value of SAR (measured) = 0.300 mW/g

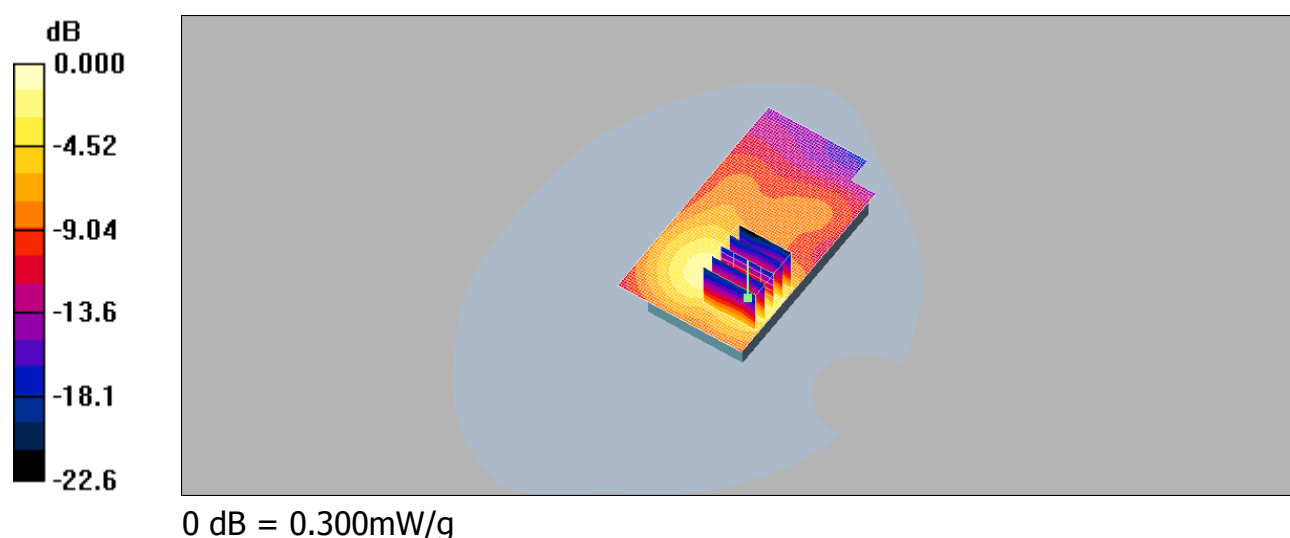

Date/Time: 2008/11/25 18:16:13

BODY_WLAN802.11 b_CH11_repeated with WELLDONE Battery

DUT: SAPP100;

Communication System: Wireless LAN; Frequency: 2462 MHz; Duty Cycle: 1:1
Medium: Muscle 2450 Medium parameters used: $f = 2462$ MHz; $\sigma = 1.96$ mho/m; $\epsilon_r = 52.6$;
 $\rho = 1000$ kg/m³
Phantom section: Flat Section

DASY4 Configuration:

- Probe: EX3DV3 - SN3526; ConvF(8.18, 8.18, 8.18); Calibrated: 2008/8/26
- Sensor-Surface: 4mm (Mechanical Surface Detection)
- Electronics: DAE4 Sn547; Calibrated: 2008/1/24
- Phantom: SAM1; Type: SAM 4.0; Serial: TP:1419
- Measurement SW: DASY4, V4.7 Build 71; Postprocessing SW: SEMCAD, V1.8 Build 184

BODY/Area Scan (51x91x1): Measurement grid: dx=15mm, dy=15mm

Maximum value of SAR (interpolated) = 0.340 mW/g

BODY/Zoom Scan (5x5x7)/Cube 0: Measurement grid: dx=8mm, dy=8mm,
dz=5mm

Reference Value = 7.67 V/m; Power Drift = 0.001 dB

Peak SAR (extrapolated) = 0.582 W/kg

SAR(1 g) = 0.295 mW/g; SAR(10 g) = 0.144 mW/g

Maximum value of SAR (measured) = 0.329 mW/g

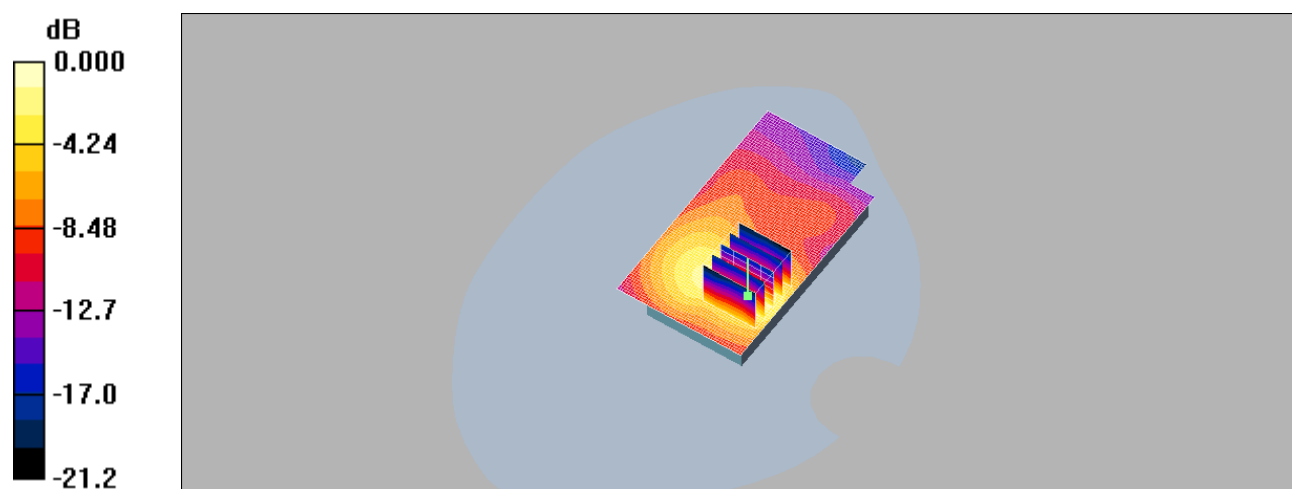

0 dB = 0.329mW/g

Date/Time: 2008/11/25 15:11:46

BODY_WLAN802.11 g_CH1

DUT: SAPP100;

Communication System: Wireless LAN; Frequency: 2412 MHz; Duty Cycle: 1:1

Medium: Muscle 2450 Medium parameters used: $f = 2412$ MHz; $\sigma = 1.9$ mho/m; $\epsilon_r = 52.8$; $\rho = 1000$ kg/m³

Phantom section: Flat Section

DASY4 Configuration:

- Probe: EX3DV3 - SN3526; ConvF(8.18, 8.18, 8.18); Calibrated: 2008/8/26
- Sensor-Surface: 4mm (Mechanical Surface Detection)
- Electronics: DAE4 Sn547; Calibrated: 2008/1/24
- Phantom: SAM1; Type: SAM 4.0; Serial: TP:1419
- Measurement SW: DASY4, V4.7 Build 71; Postprocessing SW: SEMCAD, V1.8 Build 184

BODY/Area Scan (51x91x1): Measurement grid: dx=15mm, dy=15mm

Maximum value of SAR (interpolated) = 0.049 mW/g

BODY/Zoom Scan (5x5x7)/Cube 0: Measurement grid: dx=8mm, dy=8mm, dz=5mm

Reference Value = 3.39 V/m; Power Drift = 0.012 dB

Peak SAR (extrapolated) = 0.083 W/kg

SAR(1 g) = 0.043 mW/g; SAR(10 g) = 0.021 mW/g

Maximum value of SAR (measured) = 0.048 mW/g

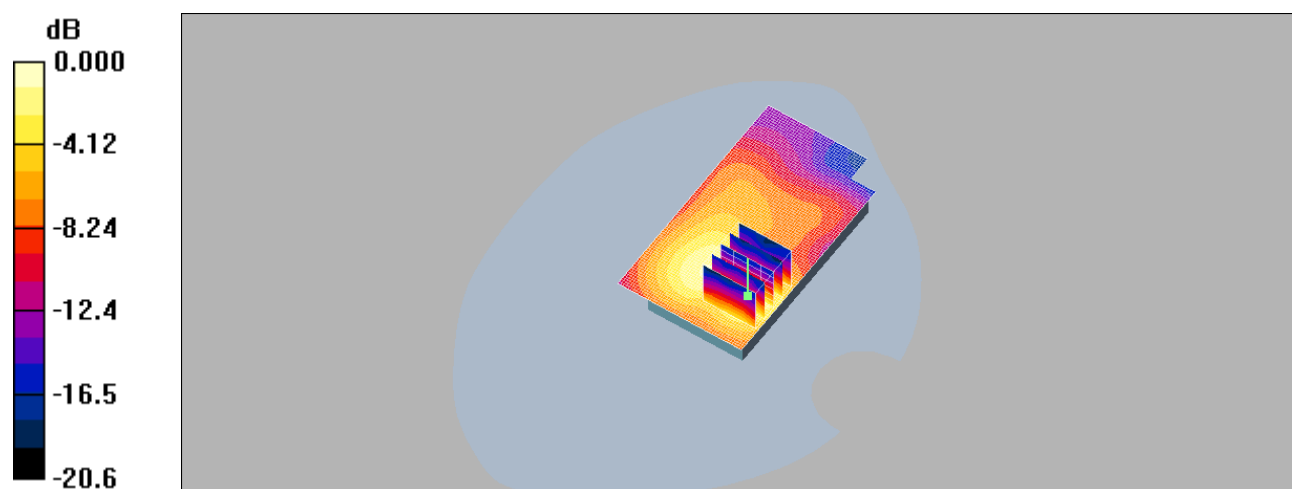

0 dB = 0.048mW/g

Date/Time: 2008/11/25 15:36:34

BODY_WLAN802.11 g_CH6

DUT: SAPP100;

Communication System: Wireless LAN; Frequency: 2437 MHz; Duty Cycle: 1:1
Medium: Muscle 2450 Medium parameters used: $f = 2437$ MHz; $\sigma = 1.92$ mho/m; $\epsilon_r = 52.7$;
 $\rho = 1000$ kg/m³
Phantom section: Flat Section

DASY4 Configuration:

- Probe: EX3DV3 - SN3526; ConvF(8.18, 8.18, 8.18); Calibrated: 2008/8/26
- Sensor-Surface: 4mm (Mechanical Surface Detection)
- Electronics: DAE4 Sn547; Calibrated: 2008/1/24
- Phantom: SAM1; Type: SAM 4.0; Serial: TP:1419
- Measurement SW: DASY4, V4.7 Build 71; Postprocessing SW: SEMCAD, V1.8 Build 184

BODY/Area Scan (51x91x1): Measurement grid: dx=15mm, dy=15mm

Maximum value of SAR (interpolated) = 0.056 mW/g

BODY/Zoom Scan (5x5x7)/Cube 0: Measurement grid: dx=8mm, dy=8mm, dz=5mm

Reference Value = 3.76 V/m; Power Drift = 0.023 dB

Peak SAR (extrapolated) = 0.102 W/kg

SAR(1 g) = 0.051 mW/g; SAR(10 g) = 0.025 mW/g

Maximum value of SAR (measured) = 0.057 mW/g

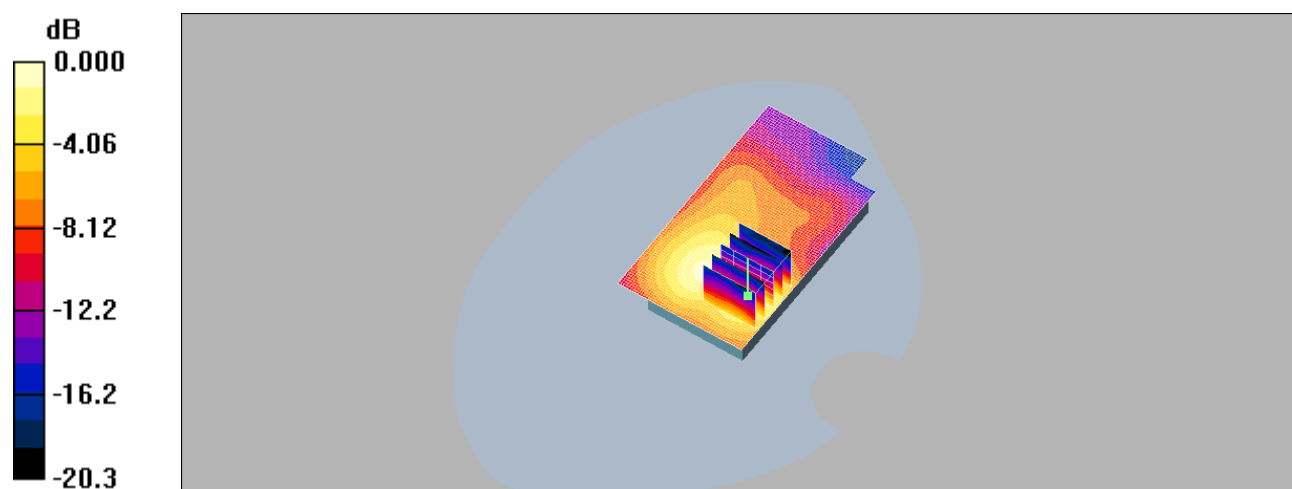

0 dB = 0.057mW/g

Date/Time: 2008/11/25 15:28:02

BODY_WLAN802.11 g_CH11

DUT: SAPP100;

Communication System: Wireless LAN; Frequency: 2462 MHz; Duty Cycle: 1:1
Medium: Muscle 2450 Medium parameters used: $f = 2462$ MHz; $\sigma = 1.96$ mho/m; $\epsilon_r = 52.6$;
 $\rho = 1000$ kg/m³
Phantom section: Flat Section

DASY4 Configuration:

- Probe: EX3DV3 - SN3526; ConvF(8.18, 8.18, 8.18); Calibrated: 2008/8/26
- Sensor-Surface: 4mm (Mechanical Surface Detection)
- Electronics: DAE4 Sn547; Calibrated: 2008/1/24
- Phantom: SAM1; Type: SAM 4.0; Serial: TP:1419
- Measurement SW: DASY4, V4.7 Build 71; Postprocessing SW: SEMCAD, V1.8 Build 184

BODY/Area Scan (51x91x1): Measurement grid: dx=15mm, dy=15mm

Maximum value of SAR (interpolated) = 0.060 mW/g

BODY/Zoom Scan (5x5x7)/Cube 0: Measurement grid: dx=8mm, dy=8mm, dz=5mm

Reference Value = 3.94 V/m; Power Drift = -0.016 dB

Peak SAR (extrapolated) = 0.107 W/kg

SAR(1 g) = 0.053 mW/g; SAR(10 g) = 0.025 mW/g

Maximum value of SAR (measured) = 0.061 mW/g

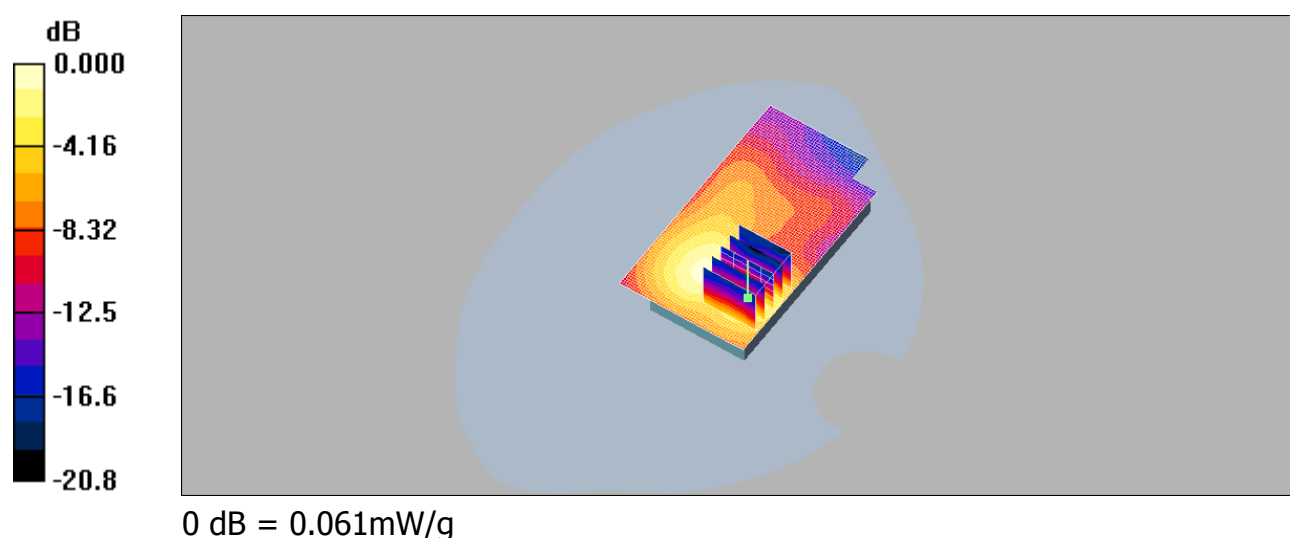

Date/Time: 2008/12/2 03:19:42

Re Cheek_CH251

DUT: SAPP100;

Communication System: GSM 850; Frequency: 848.8 MHz; Duty Cycle: 1:8.3

Medium: Head 850 MHz Medium parameters used: $f = 849$ MHz; $\sigma = 0.908$ mho/m; $\epsilon_r = 41.9$;
 $\rho = 1000$ kg/m³

Phantom section: Right Section

DASY4 Configuration:

- Probe: EX3DV3 - SN3526; ConvF(10.93, 10.93, 10.93); Calibrated: 2008/8/26
- Sensor-Surface: 4mm (Mechanical Surface Detection)
- Electronics: DAE4 Sn547; Calibrated: 2008/1/24
- Phantom: SAM1; Type: SAM 4.0; Serial: TP:1419
- Measurement SW: DASY4, V4.7 Build 71; Postprocessing SW: SEMCAD, V1.8 Build 184

RE Cheek/Area Scan (61x91x1): Measurement grid: dx=15mm, dy=15mm

Maximum value of SAR (interpolated) = 0.452 mW/g

RE Cheek/Zoom Scan (5x5x7)/Cube 0: Measurement grid: dx=8mm, dy=8mm, dz=5mm

Reference Value = 5.95 V/m; Power Drift = -0.109 dB

Peak SAR (extrapolated) = 0.533 W/kg

SAR(1 g) = 0.426 mW/g; SAR(10 g) = 0.317 mW/g

Maximum value of SAR (measured) = 0.446 mW/g

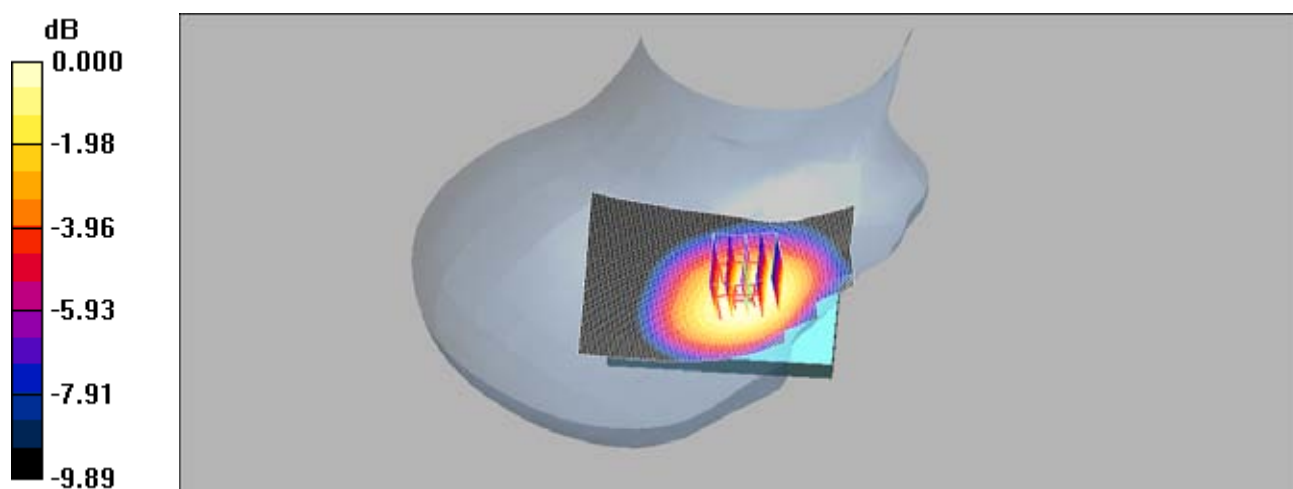

0 dB = 0.446mW/g

Date/Time: 2008/12/2 05:39:21

BODY_CH251

DUT: SAPP100;

Communication System: GSM 850; Frequency: 848.8 MHz; Duty Cycle: 1:2

Medium: Muscle 900 MHz Medium parameters used (interpolated): $f = 848.8$ MHz; $\sigma = 0.951$ mho/m; $\epsilon_r = 54.1$; $\rho = 1000$ kg/m³

Phantom section: Flat Section

DASY4 Configuration:

- Probe: EX3DV3 - SN3526; ConvF(10.87, 10.87, 10.87); Calibrated: 2008/8/26
- Sensor-Surface: 4mm (Mechanical Surface Detection)
- Electronics: DAE4 Sn547; Calibrated: 2008/1/24
- Phantom: SAM1; Type: SAM 4.0; Serial: TP:1419
- Measurement SW: DASY4, V4.7 Build 71; Postprocessing SW: SEMCAD, V1.8 Build 184

BODY/Area Scan (51x91x1): Measurement grid: dx=15mm, dy=15mm

Maximum value of SAR (interpolated) = 0.812 mW/g

BODY/Zoom Scan (5x5x7)/Cube 0: Measurement grid: dx=8mm, dy=8mm, dz=5mm

Reference Value = 8.21 V/m; Power Drift = -0.120 dB

Peak SAR (extrapolated) = 1.04 W/kg

SAR(1 g) = 0.754 mW/g; SAR(10 g) = 0.540 mW/g

Maximum value of SAR (measured) = 0.802 mW/g

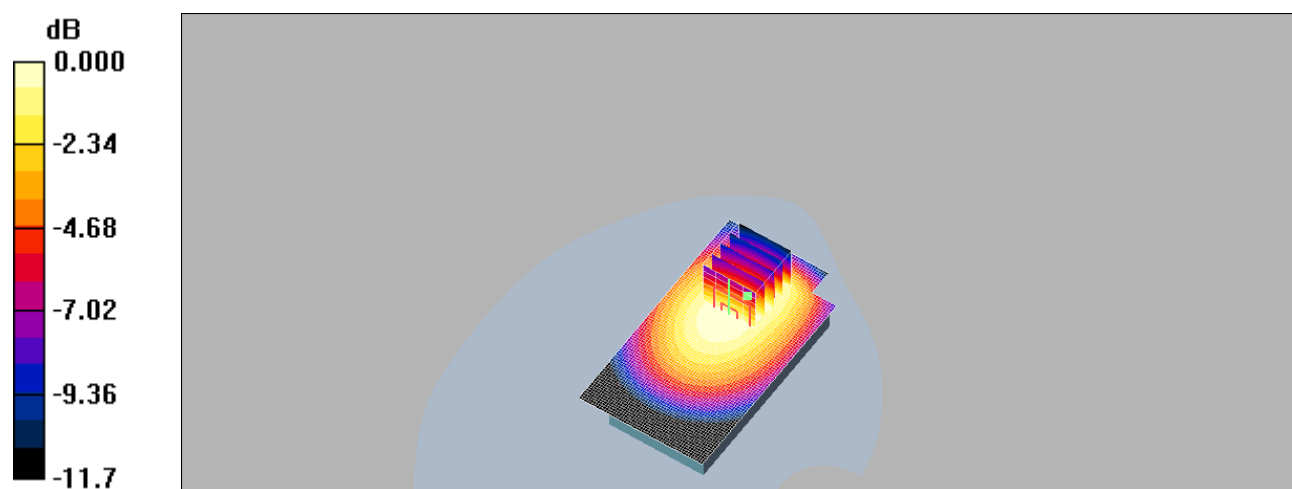

0 dB = 0.802mW/g

Date/Time: 2008/12/2 08:12:55

Le Cheek_CH810

DUT: SAPP100;

Communication System: GSM1900; Frequency: 1909.8 MHz; Duty Cycle: 1:8.3

Medium: Head 1900 MHz Medium parameters used: $f = 1910$ MHz; $\sigma = 1.41$ mho/m; $\epsilon_r = 41.1$; $\rho = 1000$ kg/m³

Phantom section: Left Section

DASY4 Configuration:

- Probe: EX3DV3 - SN3526; ConvF(9.46, 9.46, 9.46); Calibrated: 2008/8/26
- Sensor-Surface: 4mm (Mechanical Surface Detection)
- Electronics: DAE4 Sn547; Calibrated: 2008/1/24
- Phantom: SAM1; Type: SAM 4.0; Serial: TP:1419
- Measurement SW: DASY4, V4.7 Build 71; Postprocessing SW: SEMCAD, V1.8 Build 184

LE Cheek/Area Scan (61x91x1): Measurement grid: dx=15mm, dy=15mm

Maximum value of SAR (interpolated) = 0.863 mW/g

LE Cheek/Zoom Scan (5x5x7)/Cube 0: Measurement grid: dx=8mm, dy=8mm, dz=5mm

Reference Value = 8.49 V/m; Power Drift = -0.006 dB

Peak SAR (extrapolated) = 1.30 W/kg

SAR(1 g) = 0.783 mW/g; SAR(10 g) = 0.466 mW/g

Maximum value of SAR (measured) = 0.856 mW/g

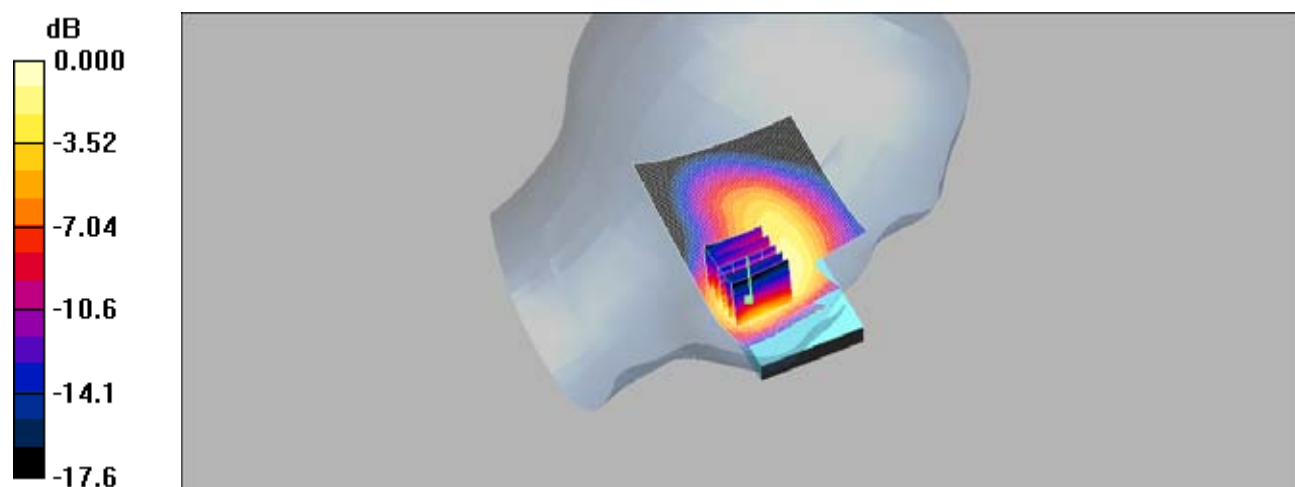

0 dB = 0.856mW/g



Date/Time: 2008/12/2 10:55:52

BODY_CH512_ repeated with WLAN802.11 b active

DUT: SAPP100;

Communication System: GSM1900; Frequency: 1850.2 MHz; Duty Cycle: 1:2
Medium: M1800 & 1900 Medium parameters used (interpolated): $f = 1850.2$ MHz; $\sigma = 1.54$ mho/m; $\epsilon_r = 51.4$; $\rho = 1000$ kg/m³
Phantom section: Flat Section

DASY4 Configuration:

- Probe: EX3DV3 - SN3526; ConvF(9.28, 9.28, 9.28); Calibrated: 2008/8/26
- Sensor-Surface: 4mm (Mechanical Surface Detection)
- Electronics: DAE4 Sn547; Calibrated: 2008/1/24
- Phantom: SAM1; Type: SAM 4.0; Serial: TP:1419
- Measurement SW: DASY4, V4.7 Build 71; Postprocessing SW: SEMCAD, V1.8 Build 184

BODY/Area Scan (51x91x1): Measurement grid: dx=15mm, dy=15mm

Maximum value of SAR (interpolated) = 1.11 mW/g

BODY/Zoom Scan (5x5x7)/Cube 0: Measurement grid: dx=8mm, dy=8mm, dz=5mm

Reference Value = 13.6 V/m; Power Drift = -0.173 dB

Peak SAR (extrapolated) = 1.61 W/kg

SAR(1 g) = 0.973 mW/g; SAR(10 g) = 0.559 mW/g

Maximum value of SAR (measured) = 1.07 mW/g

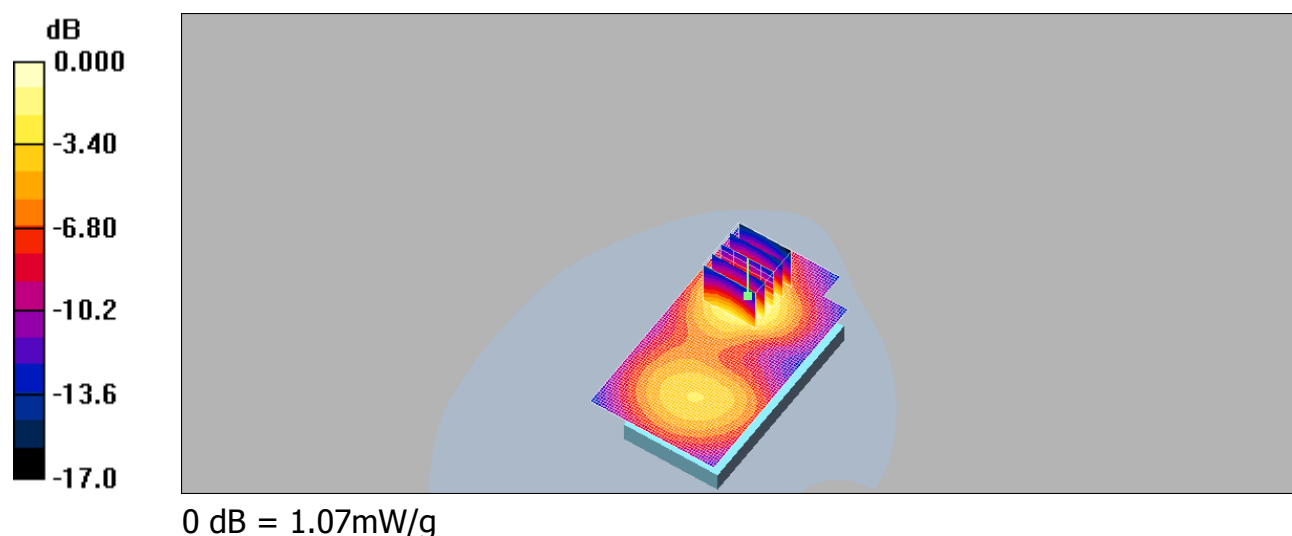



Date/Time: 2008/12/2 13:22:24

BODY_WLAN802.11 b_CH11_repeated with WELLDONE Battery

DUT: SAPP100;

Communication System: Wireless LAN; Frequency: 2462 MHz; Duty Cycle: 1:1
Medium: Muscle 2450 Medium parameters used: $f = 2462$ MHz; $\sigma = 2.07$ mho/m; $\epsilon_r = 53$; $\rho = 1000$ kg/m³
Phantom section: Flat Section

DASY4 Configuration:

- Probe: EX3DV3 - SN3526; ConvF(8.18, 8.18, 8.18); Calibrated: 2008/8/26
- Sensor-Surface: 4mm (Mechanical Surface Detection)
- Electronics: DAE4 Sn547; Calibrated: 2008/1/24
- Phantom: SAM1; Type: SAM 4.0; Serial: TP:1419
- Measurement SW: DASY4, V4.7 Build 71; Postprocessing SW: SEMCAD, V1.8 Build 184

BODY/Area Scan (51x91x1): Measurement grid: dx=15mm, dy=15mm

Maximum value of SAR (interpolated) = 0.273 mW/g

BODY/Zoom Scan (5x5x7)/Cube 0: Measurement grid: dx=8mm, dy=8mm, dz=5mm

Reference Value = 6.52 V/m; Power Drift = -0.066 dB

Peak SAR (extrapolated) = 0.514 W/kg

SAR(1 g) = 0.262 mW/g; SAR(10 g) = 0.126 mW/g

Maximum value of SAR (measured) = 0.309 mW/g

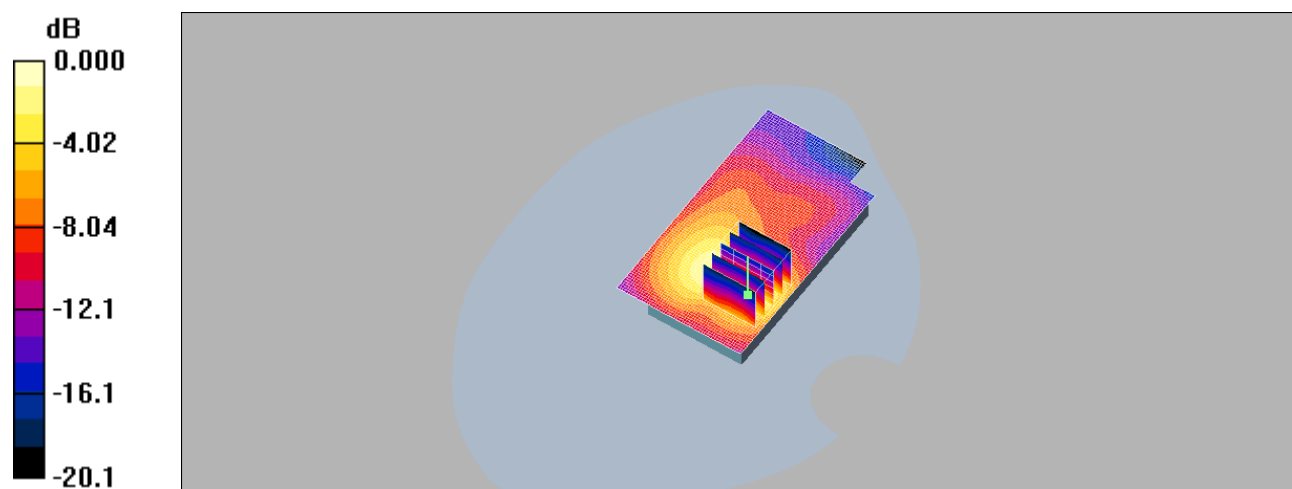

0 dB = 0.309mW/g

Date/Time: 2008/12/2 14:05:28

BODY_WLAN802.11 g_CH11

DUT: SAPP100;

Communication System: Wireless LAN; Frequency: 2462 MHz; Duty Cycle: 1:1
Medium: Muscle 2450 Medium parameters used: $f = 2462$ MHz; $\sigma = 2.097$ mho/m; $\epsilon_r = 53$; $\rho = 1000$ kg/m³
Phantom section: Flat Section

DASY4 Configuration:

- Probe: EX3DV3 - SN3526; ConvF(8.18, 8.18, 8.18); Calibrated: 2008/8/26
- Sensor-Surface: 4mm (Mechanical Surface Detection)
- Electronics: DAE4 Sn547; Calibrated: 2008/1/24
- Phantom: SAM1; Type: SAM 4.0; Serial: TP:1419
- Measurement SW: DASY4, V4.7 Build 71; Postprocessing SW: SEMCAD, V1.8 Build 184

BODY/Area Scan (51x91x1): Measurement grid: dx=15mm, dy=15mm

Maximum value of SAR (interpolated) = 0.053 mW/g

BODY/Zoom Scan (5x5x7)/Cube 0: Measurement grid: dx=8mm, dy=8mm, dz=5mm

Reference Value = 3.14 V/m; Power Drift = -0.092 dB

Peak SAR (extrapolated) = 0.084 W/kg

SAR(1 g) = 0.045 mW/g; SAR(10 g) = 0.023 mW/g

Maximum value of SAR (measured) = 0.051 mW/g

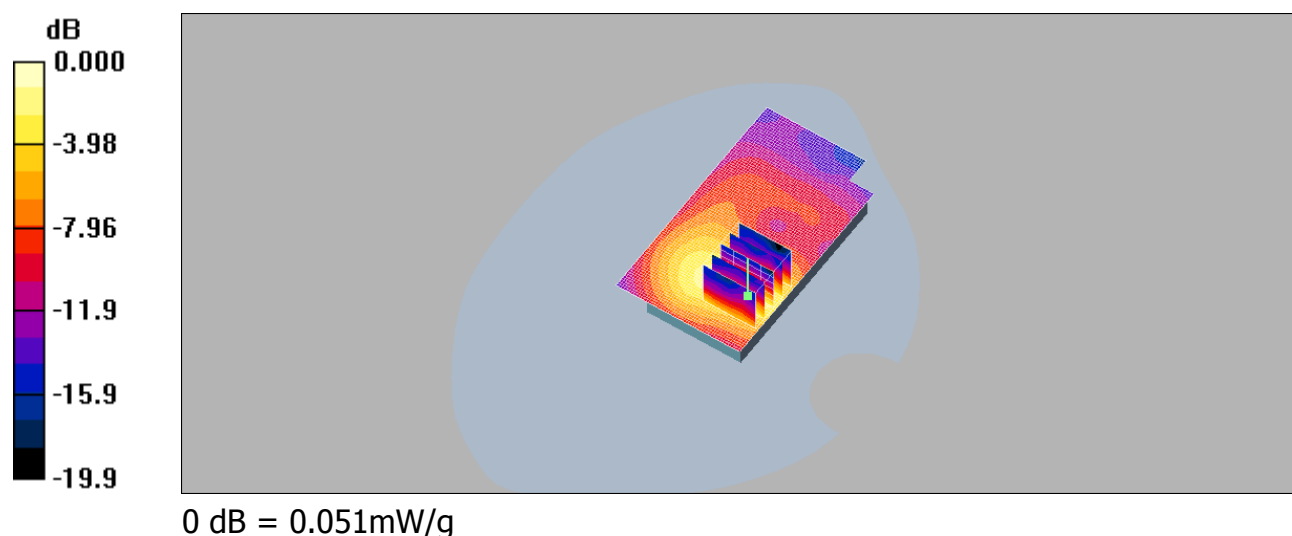

Date/Time: 2009/1/10 09:56:30

Re Cheek_CH251

DUT: SAPP 100;

Communication System: GSM 850; Frequency: 848.8 MHz; Duty Cycle: 1:8.3

Medium: Head 850 MHz Medium parameters used: $f = 849$ MHz; $\sigma = 0.916$ mho/m; $\epsilon_r = 39.7$;
 $\rho = 1000$ kg/m³

Phantom section: Right Section

DASY4 Configuration:

- Probe: EX3DV3 - SN3526; ConvF(10.93, 10.93, 10.93); Calibrated: 2008/8/26
- Sensor-Surface: 4mm (Mechanical Surface Detection)
- Electronics: DAE4 Sn547; Calibrated: 2008/1/24
- Phantom: SAM1; Type: SAM 4.0; Serial: TP:1419
- Measurement SW: DASY4, V4.7 Build 71; Postprocessing SW: SEMCAD, V1.8 Build 184

RE Cheek/Area Scan (61x91x1): Measurement grid: dx=15mm, dy=15mm
Maximum value of SAR (interpolated) = 0.396 mW/g

RE Cheek/Zoom Scan (5x5x7)/Cube 0: Measurement grid: dx=8mm, dy=8mm,
dz=5mm

Reference Value = 7.88 V/m; Power Drift = -0.051 dB

Peak SAR (extrapolated) = 0.432 W/kg

SAR(1 g) = 0.377 mW/g; SAR(10 g) = 0.287 mW/g

Maximum value of SAR (measured) = 0.398 mW/g

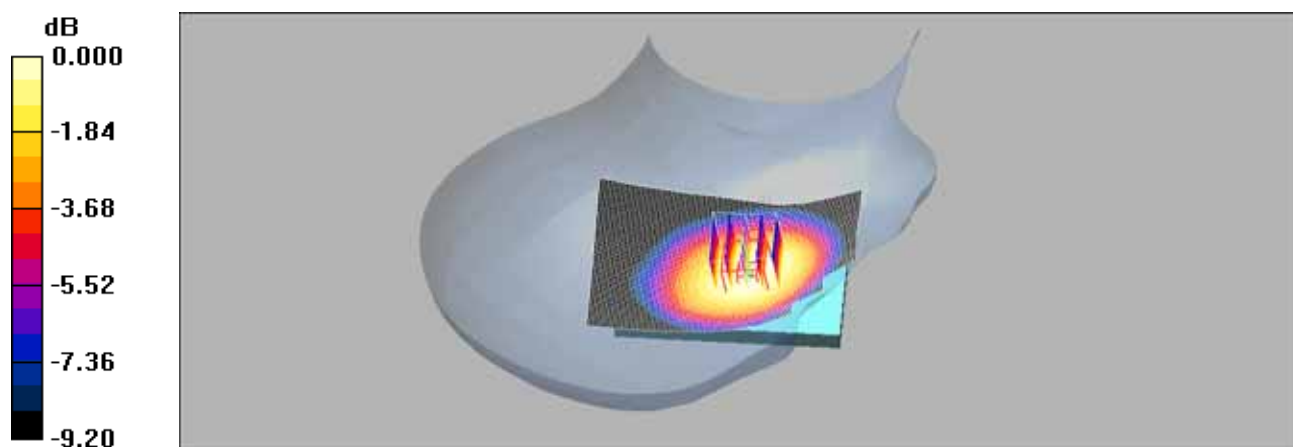

0 dB = 0.398mW/g

Date/Time: 2009/01/11 09:57:14

BODY_CH251

DUT: SAPP 100;

Communication System: GSM 850; Frequency: 848.8 MHz; Duty Cycle: 1:2

Medium: Muscle 900 MHz Medium parameters used (interpolated): $f = 848.8$ MHz; $\sigma = 0.951$ mho/m; $\epsilon_r = 54.1$; $\rho = 1000$ kg/m³

Phantom section: Flat Section

DASY4 Configuration:

- Probe: EX3DV3 - SN3526; ConvF(10.87, 10.87, 10.87); Calibrated: 2008/8/26
- Sensor-Surface: 4mm (Mechanical Surface Detection)
- Electronics: DAE4 Sn547; Calibrated: 2008/1/24
- Phantom: SAM1; Type: SAM 4.0; Serial: TP:1419
- Measurement SW: DASY4, V4.7 Build 71; Postprocessing SW: SEMCAD, V1.8 Build 184

BODY/Area Scan (51x91x1): Measurement grid: dx=15mm, dy=15mm

Maximum value of SAR (interpolated) = 0.837 mW/g

BODY/Zoom Scan (5x5x7)/Cube 0: Measurement grid: dx=8mm, dy=8mm, dz=5mm

Reference Value = 10.2 V/m; Power Drift = -0.027 dB

Peak SAR (extrapolated) = 0.961 W/kg

SAR(1 g) = 0.797 mW/g; SAR(10 g) = 0.591 mW/g

Maximum value of SAR (measured) = 0.847 mW/g

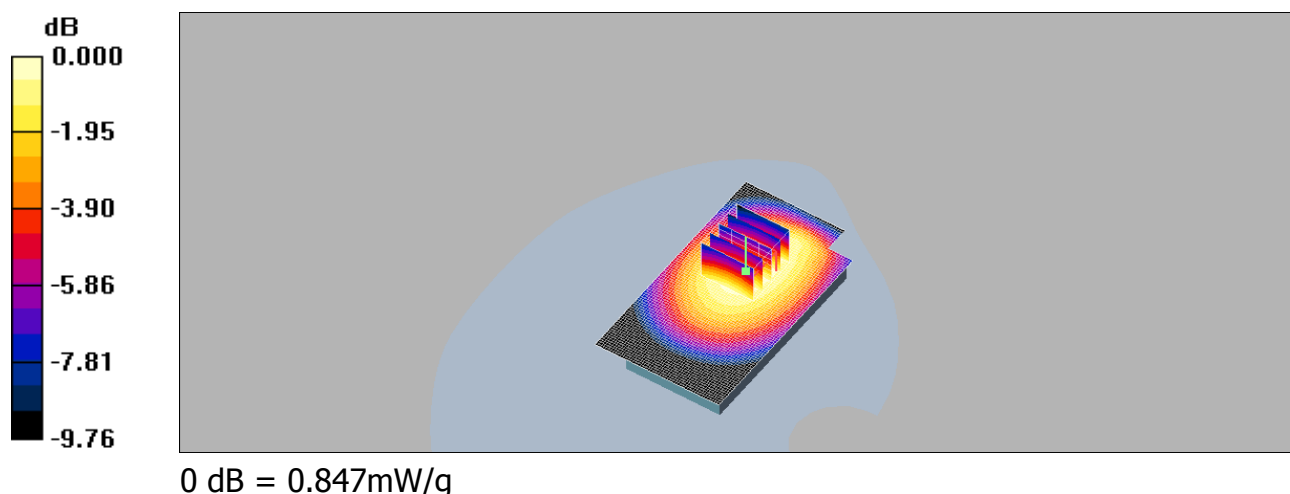

Date/Time: 2009/01/10 13:21:02

Le Cheek_CH810

DUT: SAPP 100;

Communication System: GSM1900; Frequency: 1909.8 MHz; Duty Cycle: 1:8.3

Medium: Head 1900 MHz Medium parameters used: $f = 1910$ MHz; $\sigma = 1.44$ mho/m; $\epsilon_r = 41.4$; $\rho = 1000$ kg/m³

Phantom section: Left Section

DASY4 Configuration:

- Probe: EX3DV3 - SN3526; ConvF(9.46, 9.46, 9.46); Calibrated: 2008/8/26
- Sensor-Surface: 4mm (Mechanical Surface Detection)
- Electronics: DAE4 Sn547; Calibrated: 2008/1/24
- Phantom: SAM1; Type: SAM 4.0; Serial: TP:1419
- Measurement SW: DASY4, V4.7 Build 71; Postprocessing SW: SEMCAD, V1.8 Build 184

LE Cheek/Area Scan (61x91x1): Measurement grid: dx=15mm, dy=15mm
Maximum value of SAR (interpolated) = 0.842 mW/g

LE Cheek/Zoom Scan (5x5x7)/Cube 0: Measurement grid: dx=8mm, dy=8mm, dz=5mm

Reference Value = 8.97 V/m; Power Drift = -0.128 dB

Peak SAR (extrapolated) = 1.26 W/kg

SAR(1 g) = 0.730 mW/g; SAR(10 g) = 0.430 mW/g

Maximum value of SAR (measured) = 0.782 mW/g

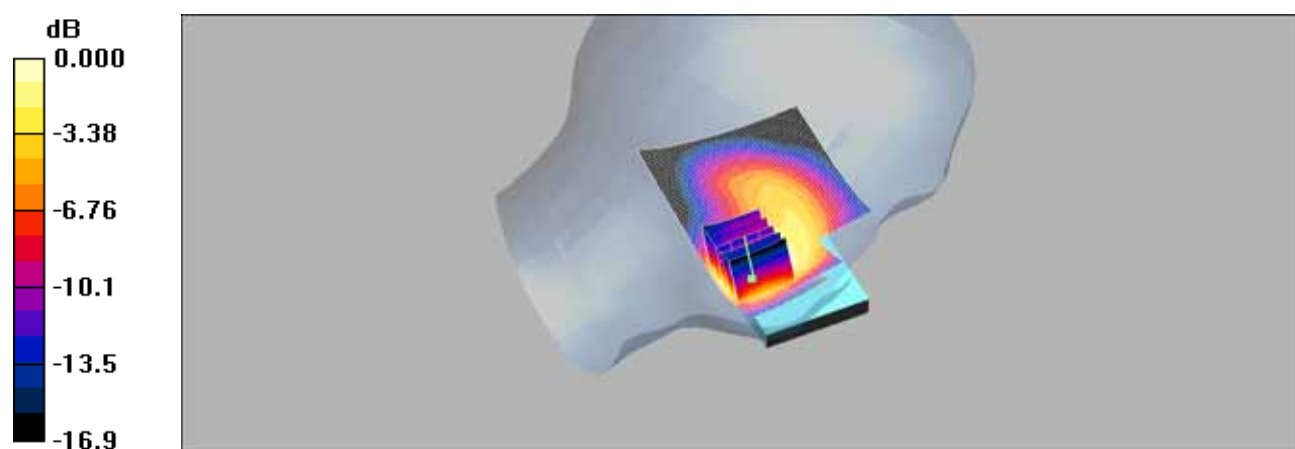

0 dB = 0.782mW/g

Date/Time: 2009/01/11 14:46:53

BODY_CH512_repeated with WLAN 802.11 b active

DUT: SAPP 100;

Communication System: GSM1900; Frequency: 1850.2 MHz; Duty Cycle: 1:2
Medium: M1800 & 1900 Medium parameters used (interpolated): $f = 1850.2$ MHz; $\sigma = 1.54$ mho/m; $\epsilon_r = 51.4$; $\rho = 1000$ kg/m³
Phantom section: Flat Section

DASY4 Configuration:

- Probe: EX3DV3 - SN3526; ConvF(9.28, 9.28, 9.28); Calibrated: 2008/8/26
- Sensor-Surface: 4mm (Mechanical Surface Detection)
- Electronics: DAE4 Sn547; Calibrated: 2008/1/24
- Phantom: SAM1; Type: SAM 4.0; Serial: TP:1419
- Measurement SW: DASY4, V4.7 Build 71; Postprocessing SW: SEMCAD, V1.8 Build 184

BODY/Area Scan (51x91x1): Measurement grid: dx=15mm, dy=15mm
Maximum value of SAR (interpolated) = 1.05 mW/g

BODY/Zoom Scan (5x5x7)/Cube 0: Measurement grid: dx=8mm, dy=8mm, dz=5mm
Reference Value = 12.5 V/m; Power Drift = -0.134 dB
Peak SAR (extrapolated) = 1.61 W/kg

SAR(1 g) = 0.928 mW/g; SAR(10 g) = 0.524 mW/g
Maximum value of SAR (measured) = 1.02 mW/g

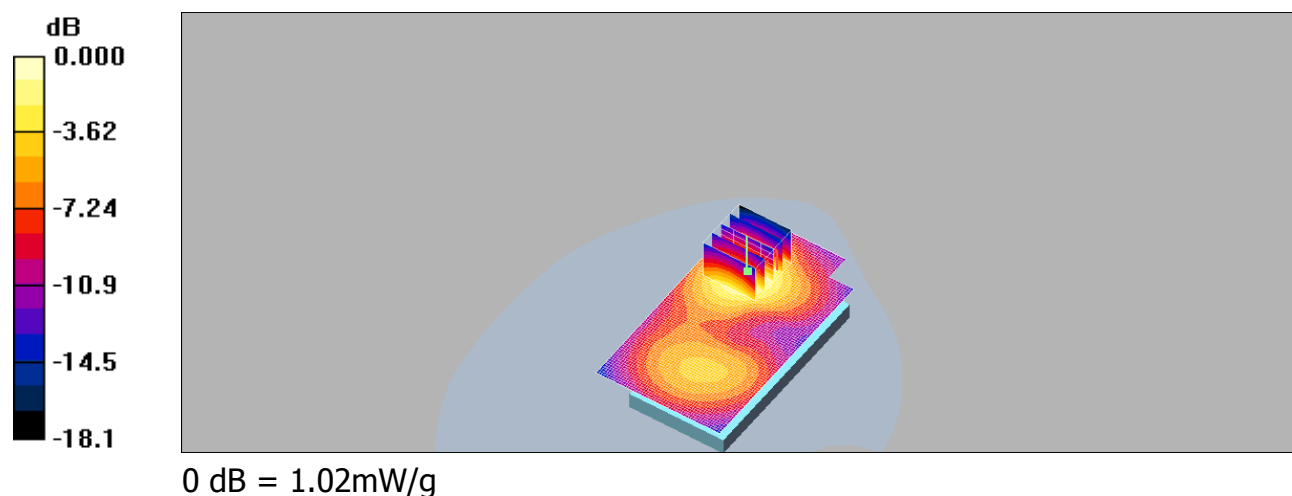

Date/Time: 2009/01/11 19:21:57

BODY_WLAN802.11 b_CH11_repeated with WELLDONE Battery

DUT: SAPP 100;

Communication System: Wireless LAN; Frequency: 2462 MHz; Duty Cycle: 1:1
Medium: Muscle 2450 Medium parameters used: $f = 2462$ MHz; $\sigma = 2.04$ mho/m; $\epsilon_r = 51.1$;
 $\rho = 1000$ kg/m³
Phantom section: Flat Section

DASY4 Configuration:

- Probe: EX3DV3 - SN3526; ConvF(8.18, 8.18, 8.18); Calibrated: 2008/8/26
- Sensor-Surface: 4mm (Mechanical Surface Detection)
- Electronics: DAE4 Sn547; Calibrated: 2008/1/24
- Phantom: SAM1; Type: SAM 4.0; Serial: TP:1419
- Measurement SW: DASY4, V4.7 Build 71; Postprocessing SW: SEMCAD, V1.8 Build 184

BODY/Area Scan (51x91x1): Measurement grid: dx=15mm, dy=15mm
Maximum value of SAR (interpolated) = 0.329 mW/g

BODY/Zoom Scan (5x5x7)/Cube 0: Measurement grid: dx=8mm, dy=8mm,
dz=5mm
Reference Value = 8.41 V/m; Power Drift = 0.004 dB
Peak SAR (extrapolated) = 0.697 W/kg

SAR(1 g) = 0.306 mW/g; SAR(10 g) = 0.139 mW/g
Maximum value of SAR (measured) = 0.363 mW/g

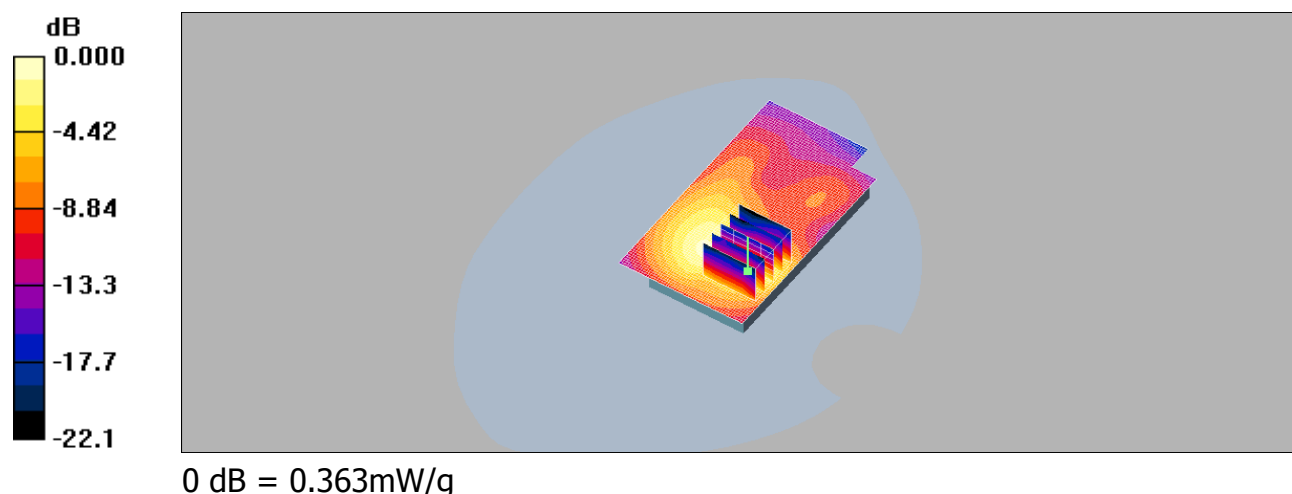

Date/Time: 2009/01/11 19:59:41

BODY_WLAN802.11 g_CH11

DUT: SAPP 100;

Communication System: Wireless LAN; Frequency: 2462 MHz; Duty Cycle: 1:1
Medium: Muscle 2450 Medium parameters used: $f = 2462$ MHz; $\sigma = 2.04$ mho/m; $\epsilon_r = 51.1$;
 $\rho = 1000$ kg/m³
Phantom section: Flat Section

DASY4 Configuration:

- Probe: EX3DV3 - SN3526; ConvF(8.18, 8.18, 8.18); Calibrated: 2008/8/26
- Sensor-Surface: 4mm (Mechanical Surface Detection)
- Electronics: DAE4 Sn547; Calibrated: 2008/1/24
- Phantom: SAM1; Type: SAM 4.0; Serial: TP:1419
- Measurement SW: DASY4, V4.7 Build 71; Postprocessing SW: SEMCAD, V1.8 Build 184

BODY/Area Scan (51x91x1): Measurement grid: dx=15mm, dy=15mm
Maximum value of SAR (interpolated) = 0.063 mW/g

BODY/Zoom Scan (5x5x7)/Cube 0: Measurement grid: dx=8mm, dy=8mm,
dz=5mm
Reference Value = 3.78 V/m; Power Drift = -0.059 dB
Peak SAR (extrapolated) = 0.113 W/kg

SAR(1 g) = 0.055 mW/g; SAR(10 g) = 0.025 mW/g
Maximum value of SAR (measured) = 0.067 mW/g

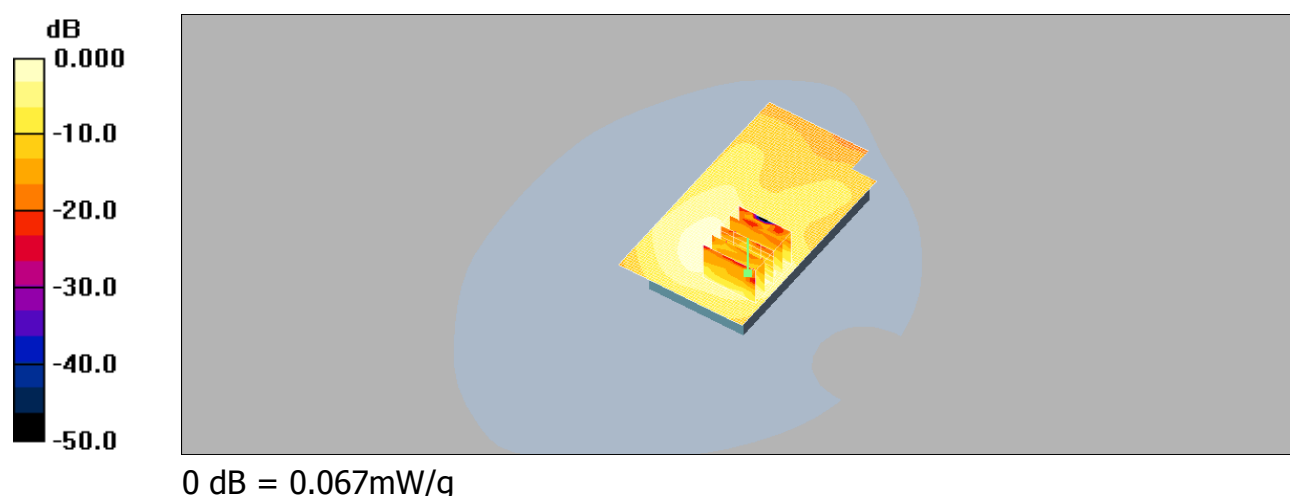

Date/Time: 2009/01/10 10:38:14

Re Cheek_CH251

DUT: SAPP 100;

Communication System: GSM 850; Frequency: 848.8 MHz; Duty Cycle: 1:8.3

Medium: Head 850 MHz Medium parameters used: $f = 849$ MHz; $\sigma = 0.916$ mho/m; $\epsilon_r = 39.7$;
 $\rho = 1000$ kg/m³

Phantom section: Right Section

DASY4 Configuration:

- Probe: EX3DV3 - SN3526; ConvF(10.93, 10.93, 10.93); Calibrated: 2008/8/26
- Sensor-Surface: 4mm (Mechanical Surface Detection)
- Electronics: DAE4 Sn547; Calibrated: 2008/1/24
- Phantom: SAM1; Type: SAM 4.0; Serial: TP:1419
- Measurement SW: DASY4, V4.7 Build 71; Postprocessing SW: SEMCAD, V1.8 Build 184

RE Cheek/Area Scan (61x91x1): Measurement grid: dx=15mm, dy=15mm
Maximum value of SAR (interpolated) = 0.434 mW/g

RE Cheek/Zoom Scan (5x5x7)/Cube 0: Measurement grid: dx=8mm, dy=8mm,
dz=5mm

Reference Value = 8.05 V/m; Power Drift = -0.142 dB

Peak SAR (extrapolated) = 0.479 W/kg

SAR(1 g) = 0.409 mW/g; SAR(10 g) = 0.308 mW/g

Maximum value of SAR (measured) = 0.431 mW/g

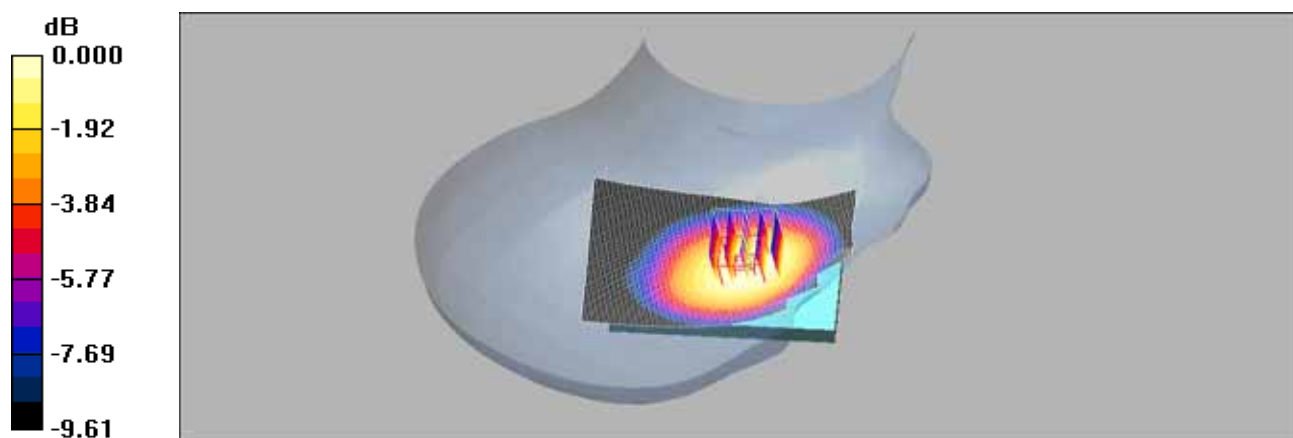

0 dB = 0.431mW/g

Date/Time: 2009/01/11 10:48:01

BODY_CH251

DUT: SAPP 100;

Communication System: GSM 850; Frequency: 848.8 MHz; Duty Cycle: 1:2

Medium: Muscle 900 MHz Medium parameters used (interpolated): $f = 848.8$ MHz; $\sigma = 0.951$ mho/m; $\epsilon_r = 54.1$; $\rho = 1000$ kg/m³

Phantom section: Flat Section

- Probe: EX3DV3 - SN3526; ConvF(10.87, 10.87, 10.87); Calibrated: 2008/8/26
- Sensor-Surface: 4mm (Mechanical Surface Detection)
- Electronics: DAE4 Sn547; Calibrated: 2008/1/24
- Phantom: SAM1; Type: SAM 4.0; Serial: TP:1419
- Measurement SW: DASy4, V4.7 Build 71; Postprocessing SW: SEMCAD, V1.8 Build 184

BODY/Area Scan (51x91x1): Measurement grid: dx=15mm, dy=15mm

Maximum value of SAR (interpolated) = 0.901 mW/g

BODY/Zoom Scan (5x5x7)/Cube 0: Measurement grid: dx=8mm, dy=8mm, dz=5mm

Reference Value = 10.7 V/m; Power Drift = -0.036 dB

Peak SAR (extrapolated) = 1.03 W/kg

SAR(1 g) = 0.856 mW/g; SAR(10 g) = 0.637 mW/g

Maximum value of SAR (measured) = 0.903 mW/g

BODY/Zoom Scan (5x5x7)/Cube 1: Measurement grid: dx=8mm, dy=8mm, dz=5mm

Reference Value = 10.7 V/m; Power Drift = -0.036 dB

Peak SAR (extrapolated) = 0.977 W/kg

SAR(1 g) = 0.750 mW/g; SAR(10 g) = 0.495 mW/g

Maximum value of SAR (measured) = 0.824 mW/g

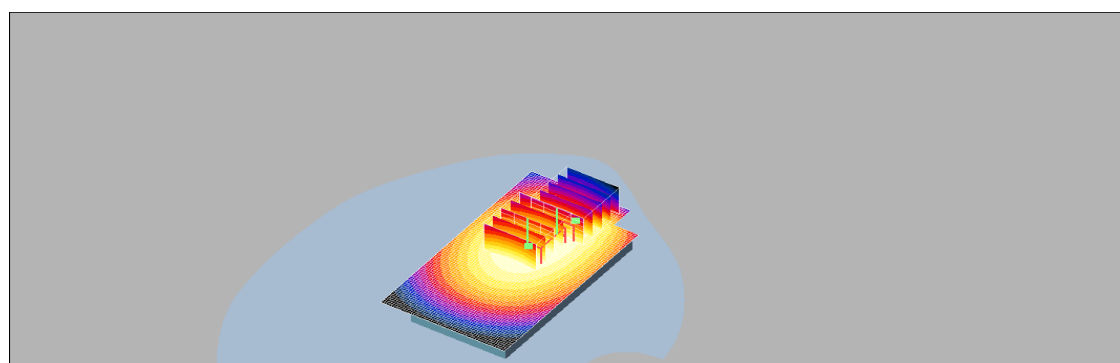
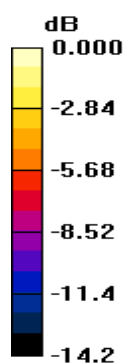

0 dB = 0.824mW/g

Date/Time: 2009/01/10 14:08:00

Le Cheek_CH810

DUT: SAPP 100;

Communication System: GSM1900; Frequency: 1909.8 MHz; Duty Cycle: 1:8.3
Medium: Head 1900 MHz Medium parameters used: $f = 1910$ MHz; $\sigma = 1.44$ mho/m; $\epsilon_r = 41.4$; $\rho = 1000$ kg/m³
Phantom section: Left Section

DASY4 Configuration:

- Probe: EX3DV3 - SN3526; ConvF(9.46, 9.46, 9.46); Calibrated: 2008/8/26
- Sensor-Surface: 4mm (Mechanical Surface Detection)
- Electronics: DAE4 Sn547; Calibrated: 2008/1/24
- Phantom: SAM1; Type: SAM 4.0; Serial: TP:1419
- Measurement SW: DASY4, V4.7 Build 71; Postprocessing SW: SEMCAD, V1.8 Build 184

LE Cheek/Area Scan (61x91x1): Measurement grid: dx=15mm, dy=15mm
Maximum value of SAR (interpolated) = 0.846 mW/g

LE Cheek/Zoom Scan (5x5x7)/Cube 0: Measurement grid: dx=8mm, dy=8mm, dz=5mm

Reference Value = 9.32 V/m; Power Drift = -0.027 dB

Peak SAR (extrapolated) = 1.26 W/kg

SAR(1 g) = 0.749 mW/g; SAR(10 g) = 0.442 mW/g

Maximum value of SAR (measured) = 0.796 mW/g

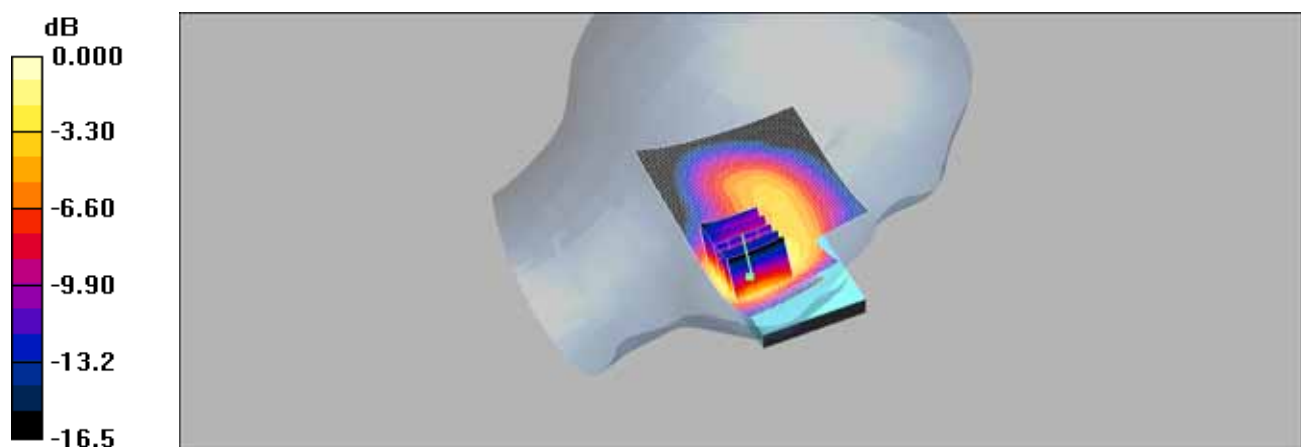

Date/Time: 2009/01/11 15:37:54

BODY_CH512_repeated with WLAN 802.11b active

DUT: SAPP 100;

Communication System: GSM1900; Frequency: 1850.2 MHz; Duty Cycle: 1:2
Medium: M1800 & 1900 Medium parameters used (interpolated): $f = 1850.2$ MHz; $\sigma = 1.54$ mho/m; $\epsilon_r = 51.4$; $\rho = 1000$ kg/m³
Phantom section: Flat Section

DASY4 Configuration:

- Probe: EX3DV3 - SN3526; ConvF(9.28, 9.28, 9.28); Calibrated: 2008/8/26
- Sensor-Surface: 4mm (Mechanical Surface Detection)
- Electronics: DAE4 Sn547; Calibrated: 2008/1/24
- Phantom: SAM1; Type: SAM 4.0; Serial: TP:1419
- Measurement SW: DASY4, V4.7 Build 71; Postprocessing SW: SEMCAD, V1.8 Build 184

BODY/Area Scan (51x91x1): Measurement grid: dx=15mm, dy=15mm
Maximum value of SAR (interpolated) = 1.07 mW/g

BODY/Zoom Scan (5x5x7)/Cube 0: Measurement grid: dx=8mm, dy=8mm, dz=5mm
Reference Value = 13.2 V/m; Power Drift = -0.084 dB
Peak SAR (extrapolated) = 1.60 W/kg

SAR(1 g) = 0.953 mW/g; SAR(10 g) = 0.548 mW/g
Maximum value of SAR (measured) = 1.06 mW/g

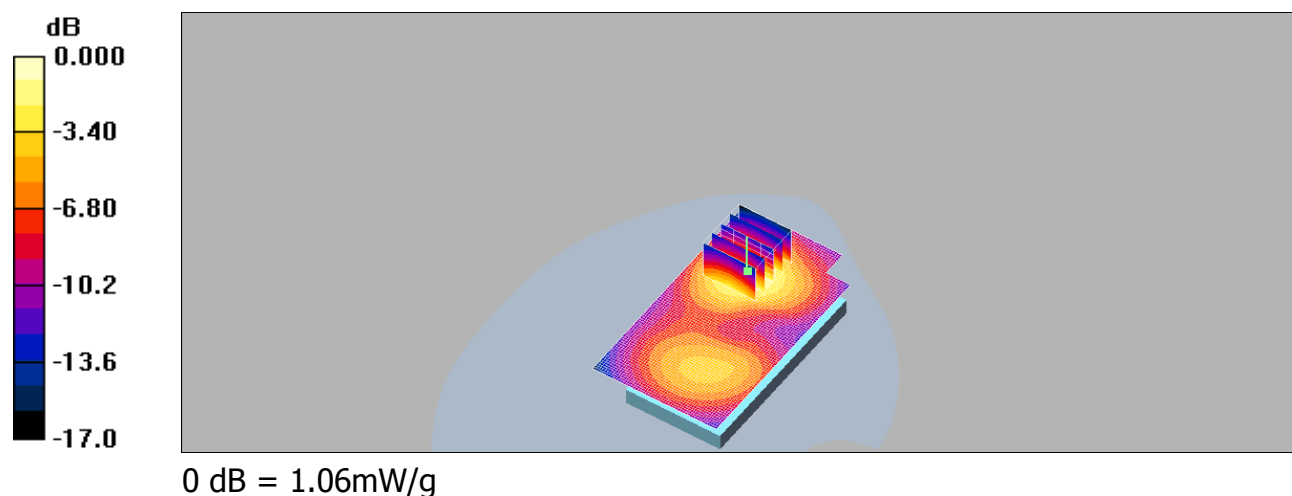

Date/Time: 2009/01/11 20:36:22

BODY_WLAN802.11 b_CH11 repeated with WELLDONE battery

DUT: SAPP 100;

Communication System: Wireless LAN; Frequency: 2462 MHz; Duty Cycle: 1:1
Medium: Muscle 2450 Medium parameters used: $f = 2462$ MHz; $\sigma = 2.04$ mho/m; $\epsilon_r = 51.1$;
 $\rho = 1000$ kg/m³
Phantom section: Flat Section

DASY4 Configuration:

- Probe: EX3DV3 - SN3526; ConvF(8.18, 8.18, 8.18); Calibrated: 2008/8/26
- Sensor-Surface: 4mm (Mechanical Surface Detection)
- Electronics: DAE4 Sn547; Calibrated: 2008/1/24
- Phantom: SAM1; Type: SAM 4.0; Serial: TP:1419
- Measurement SW: DASY4, V4.7 Build 71; Postprocessing SW: SEMCAD, V1.8 Build 184

BODY/Area Scan (51x91x1): Measurement grid: dx=15mm, dy=15mm
Maximum value of SAR (interpolated) = 0.327 mW/g

BODY/Zoom Scan (5x5x7)/Cube 0: Measurement grid: dx=8mm, dy=8mm,
dz=5mm

Reference Value = 8.29 V/m; Power Drift = 0.081 dB

Peak SAR (extrapolated) = 0.680 W/kg

SAR(1 g) = 0.300 mW/g; SAR(10 g) = 0.137 mW/g

Maximum value of SAR (measured) = 0.356 mW/g

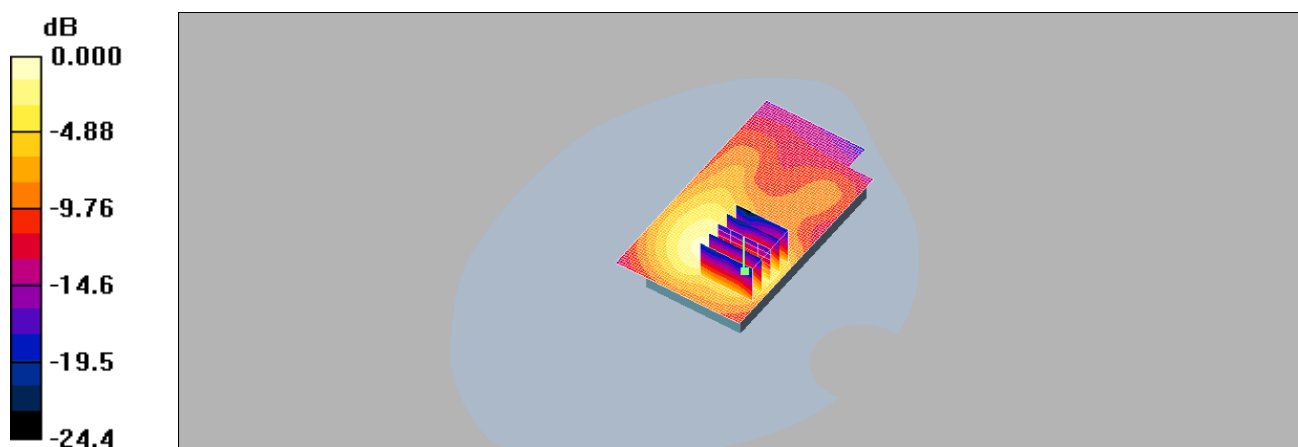

0 dB = 0.356mW/g

Date/Time: 2009/01/11 21:09:49

BODY_WLAN802.11 g_CH11

DUT: SAPP 100;

Communication System: Wireless LAN; Frequency: 2462 MHz; Duty Cycle: 1:1
Medium: Muscle 2450 Medium parameters used: $f = 2462$ MHz; $\sigma = 2.04$ mho/m; $\epsilon_r = 51.1$;
 $\rho = 1000$ kg/m³
Phantom section: Flat Section

DASY4 Configuration:

- Probe: EX3DV3 - SN3526; ConvF(8.18, 8.18, 8.18); Calibrated: 2008/8/26
- Sensor-Surface: 4mm (Mechanical Surface Detection)
- Electronics: DAE4 Sn547; Calibrated: 2008/1/24
- Phantom: SAM1; Type: SAM 4.0; Serial: TP:1419
- Measurement SW: DASY4, V4.7 Build 71; Postprocessing SW: SEMCAD, V1.8 Build 184

BODY/Area Scan (51x91x1): Measurement grid: dx=15mm, dy=15mm
Maximum value of SAR (interpolated) = 0.066 mW/g

BODY/Zoom Scan (5x5x7)/Cube 0: Measurement grid: dx=8mm, dy=8mm,
dz=5mm
Reference Value = 3.40 V/m; Power Drift = 0.018 dB
Peak SAR (extrapolated) = 0.109 W/kg

SAR(1 g) = 0.055 mW/g; SAR(10 g) = 0.025 mW/g
Maximum value of SAR (measured) = 0.064 mW/g

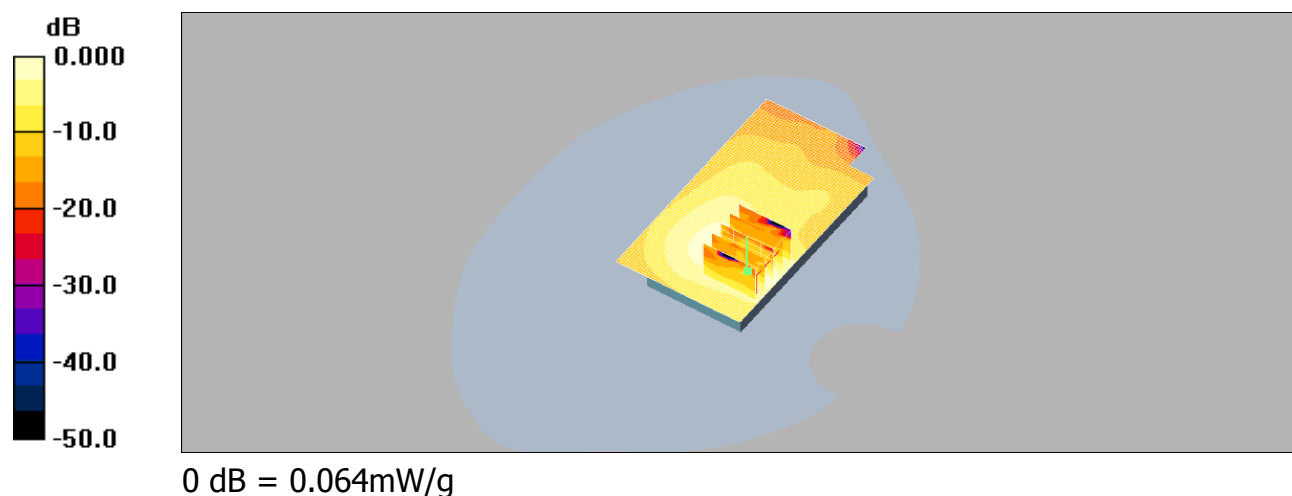

5. System Verification

Date/Time: 2008/11/25 01:22:15

DUT: Dipole 835 MHz;

Communication System: CW; Frequency: 835 MHz; Duty Cycle: 1:1

Medium: Head 900 MHz Medium parameters used: $f = 835$ MHz; $\sigma = 0.908$ mho/m; $\epsilon_r = 42.1$;
 $\rho = 1000$ kg/m³

Phantom section: Flat Section

DASY4 Configuration:

- Probe: EX3DV3 - SN3526; ConvF(10.93, 10.93, 10.93); Calibrated: 2008/8/26
- Sensor-Surface: 4mm (Mechanical Surface Detection)
- Electronics: DAE4 Sn547; Calibrated: 2008/1/24
- Phantom: SAM1; Type: SAM 4.0; Serial: TP:1419
- Measurement SW: DASY4, V4.7 Build 71; Postprocessing SW: SEMCAD, V1.8 Build 184

Pin=250mW/Area Scan (61x61x1): Measurement grid: dx=15mm, dy=15mm

Maximum value of SAR (interpolated) = 2.60 mW/g

Pin=250mW/Zoom Scan (7x7x7)/Cube 0: Measurement grid: dx=5mm, dy=5mm, dz=5mm

Reference Value = 53.3 V/m; Power Drift = 0.004 dB

Peak SAR (extrapolated) = 3.66 W/kg

SAR(1 g) = 2.4 mW/g; SAR(10 g) = 1.55 mW/g

Maximum value of SAR (measured) = 2.58 mW/g

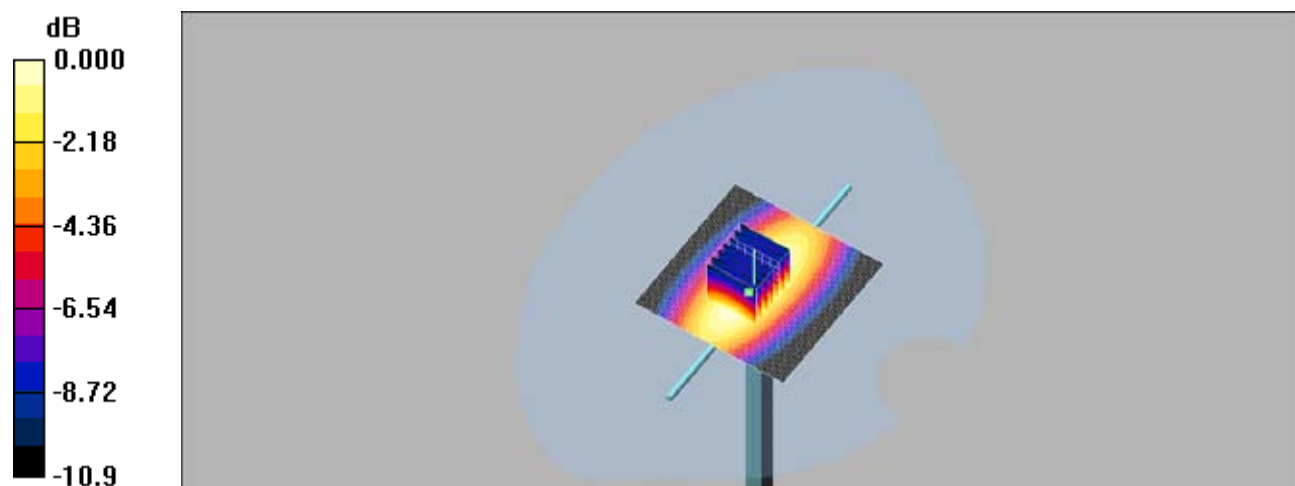

0 dB = 2.58mW/g

Date/Time: 2008/11/25 08:39:29

DUT: Dipole 835 MHz;

Communication System: CW; Frequency: 835 MHz; Duty Cycle: 1:1

Medium: Muscle 900 MHz Medium parameters used (interpolated): $f = 835$ MHz; $\sigma = 0.945$ mho/m; $\epsilon_r = 54.3$; $\rho = 1000$ kg/m³

Phantom section: Flat Section

DASY4 Configuration:

- Probe: EX3DV3 - SN3526; ConvF(10.87, 10.87, 10.87); Calibrated: 2008/8/26
- Sensor-Surface: 4mm (Mechanical Surface Detection)
- Electronics: DAE4 Sn547; Calibrated: 2008/1/24
- Phantom: SAM1; Type: SAM 4.0; Serial: TP:1419
- Measurement SW: DASY4, V4.7 Build 71; Postprocessing SW: SEMCAD, V1.8 Build 184

Pin=250mW/Area Scan (61x61x1): Measurement grid: dx=15mm, dy=15mm
Maximum value of SAR (interpolated) = 2.90 mW/g

Pin=250mW/Zoom Scan (7x7x7)/Cube 0: Measurement grid: dx=5mm, dy=5mm, dz=5mm

Reference Value = 55.6 V/m; Power Drift = 0.010 dB

Peak SAR (extrapolated) = 4.00 W/kg

SAR(1 g) = 2.48 mW/g; SAR(10 g) = 1.67 mW/g

Maximum value of SAR (measured) = 2.90 mW/g

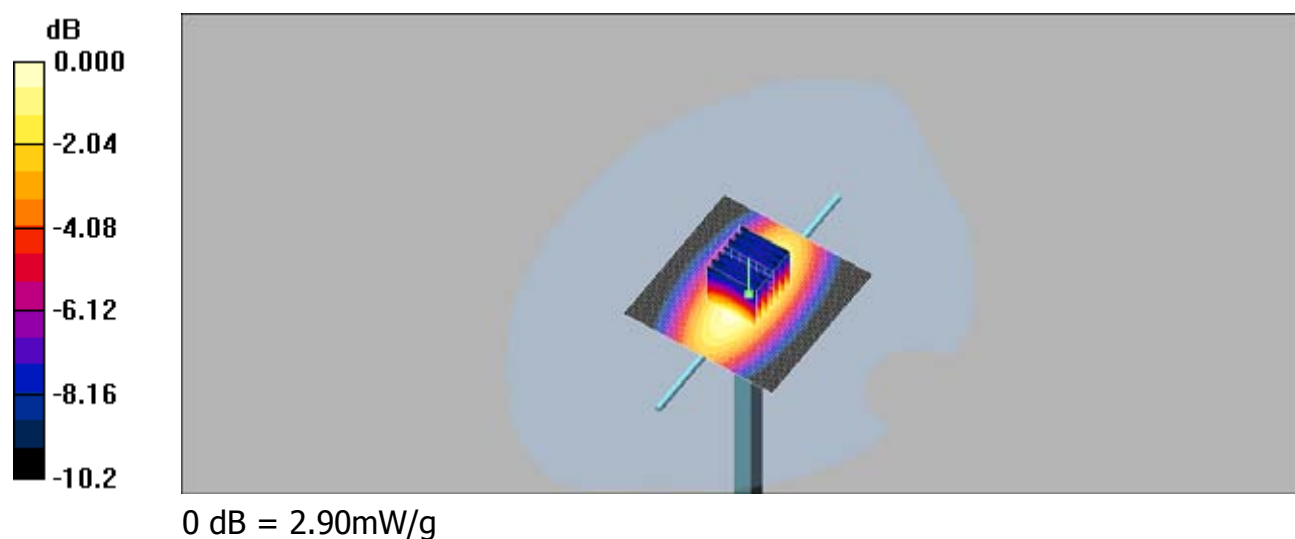

Date/Time: 2008/11/26 00:31:24

DUT: Dipole 1900 MHz;

Communication System: CW; Frequency: 1900 MHz; Duty Cycle: 1:1
Medium: Head 1900MHz Medium parameters used: $f = 1900$ MHz; $\sigma = 1.42$ mho/m; $\epsilon_r = 41.2$; $\rho = 1000$ kg/m³
Phantom section: Flat Section

DASY4 Configuration:

- Probe: EX3DV3 - SN3526; ConvF(9.46, 9.46, 9.46); Calibrated: 2008/8/26
- Sensor-Surface: 4mm (Mechanical Surface Detection)
- Electronics: DAE4 Sn547; Calibrated: 2008/1/24
- Phantom: SAM1; Type: SAM 4.0; Serial: TP:1419
- Measurement SW: DASY4, V4.7 Build 71; Postprocessing SW: SEMCAD, V1.8 Build 184

Pin=250mw/Area Scan (51x61x1): Measurement grid: dx=15mm, dy=15mm
Maximum value of SAR (interpolated) = 13.4 mW/g

Pin=250mw/Zoom Scan (7x7x7)/Cube 0: Measurement grid: dx=5mm, dy=5mm, dz=5mm
Reference Value = 90.7 V/m; Power Drift = -0.009 dB
Peak SAR (extrapolated) = 19.8 W/kg

SAR(1 g) = 10.2 mW/g; SAR(10 g) = 5.24 mW/g
Maximum value of SAR (measured) = 11.5 mW/g

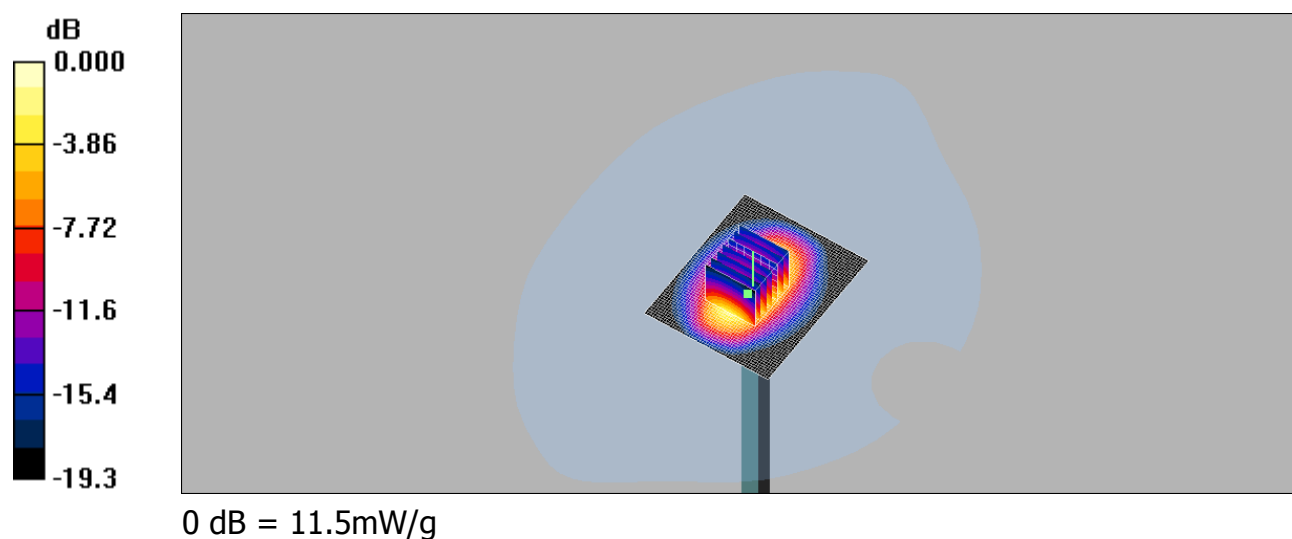

Date/Time: 2008/11/26 12:39:52

DUT: Dipole 1900 MHz;

Communication System: CW; Frequency: 1900 MHz; Duty Cycle: 1:1
Medium: M1800 & 1900 Medium parameters used: $f = 1900$ MHz; $\sigma = 1.57$ mho/m; $\epsilon_r = 51.1$;
 $\rho = 1000$ kg/m³
Phantom section: Flat Section

DASY4 Configuration:

- Probe: EX3DV3 - SN3526; ConvF(9.28, 9.28, 9.28); Calibrated: 2008/8/26
- Sensor-Surface: 4mm (Mechanical Surface Detection)
- Electronics: DAE4 Sn547; Calibrated: 2008/1/24
- Phantom: SAM1; Type: SAM 4.0; Serial: TP:1419
- Measurement SW: DASY4, V4.7 Build 71; Postprocessing SW: SEMCAD, V1.8 Build 184

Pin=250mW/Area Scan (51x61x1): Measurement grid: dx=15mm, dy=15mm
Maximum value of SAR (interpolated) = 12.5 mW/g

Pin=250mW/Zoom Scan (7x7x7)/Cube 0: Measurement grid: dx=5mm,
dy=5mm, dz=5mm

Reference Value = 82.4 V/m; Power Drift = -0.018 dB

Peak SAR (extrapolated) = 17.3 W/kg

SAR(1 g) = 9.53 mW/g; SAR(10 g) = 5 mW/g

Maximum value of SAR (measured) = 10.7 mW/g

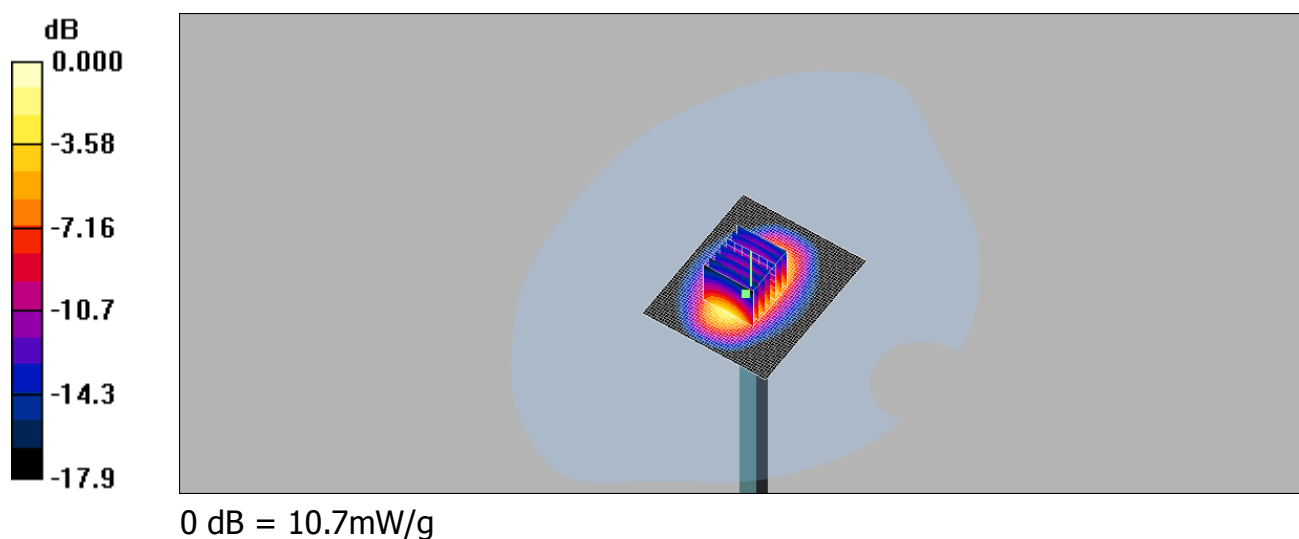

Date/Time: 2008/11/25 12:53:47

DUT: Dipole 2450 MHz;

Communication System: CW; Frequency: 2450 MHz; Duty Cycle: 1:1

Medium: M 2450 Medium parameters used: $f = 2450$ MHz; $\sigma = 1.94$ mho/m; $\epsilon_r = 52.7$; $\rho = 1000$ kg/m³

Phantom section: Flat Section

DASY4 Configuration:

- Probe: EX3DV3 - SN3526; ConvF(8.18, 8.18, 8.18); Calibrated: 2008/8/26
- Sensor-Surface: 4mm (Mechanical Surface Detection)
- Electronics: DAE4 Sn547; Calibrated: 2008/1/24
- Phantom: SAM1; Type: SAM 4.0; Serial: TP:1419
- Measurement SW: DASY4, V4.7 Build 71; Postprocessing SW: SEMCAD, V1.8 Build 184

Pin=250mW/Area Scan (51x61x1): Measurement grid: dx=15mm, dy=15mm
Maximum value of SAR (interpolated) = 17.9 mW/g

Pin=250mW/Zoom Scan (7x7x7)/Cube 0: Measurement grid: dx=5mm, dy=5mm, dz=5mm

Reference Value = 85.8 V/m; Power Drift = -0.029 dB

Peak SAR (extrapolated) = 27.0 W/kg

SAR(1 g) = 13.1 mW/g; SAR(10 g) = 6 mW/g

Maximum value of SAR (measured) = 14.8 mW/g

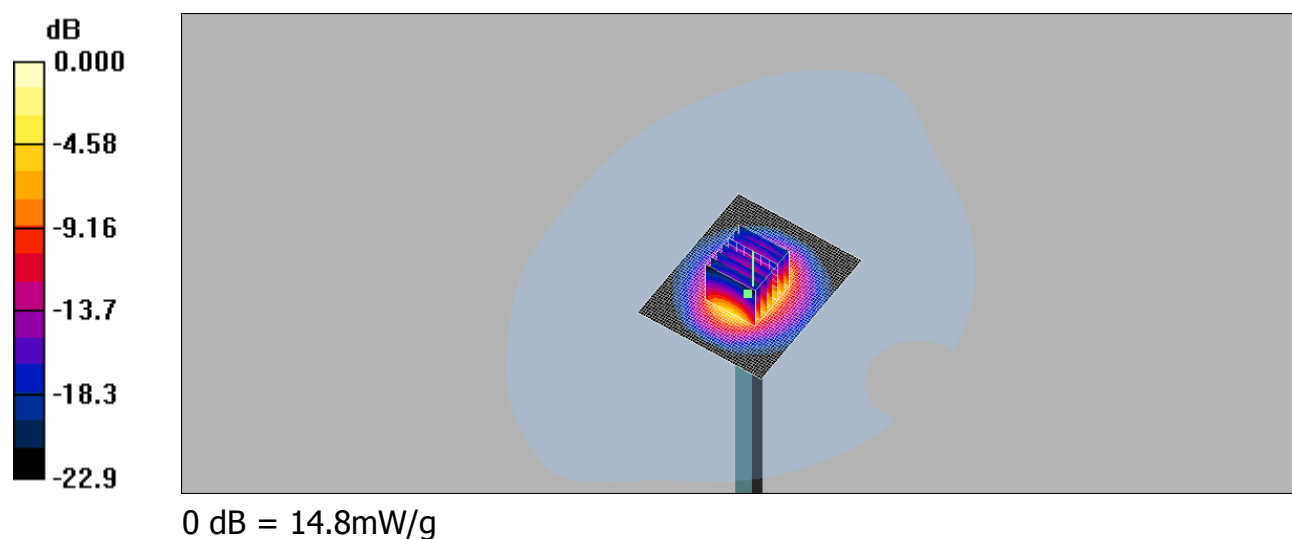

Date/Time: 2008/12/2 02:33:13

DUT: Dipole 835 MHz;

Communication System: CW; Frequency: 835 MHz; Duty Cycle: 1:1
Medium: Head 900 MHz Medium parameters used: $f = 835$ MHz; $\sigma = 0.895$ mho/m; $\epsilon_r = 42.1$;
 $\rho = 1000$ kg/m³
Phantom section: Flat Section

DASY4 Configuration:

- Probe: EX3DV3 - SN3526; ConvF(10.93, 10.93, 10.93); Calibrated: 2008/8/26
- Sensor-Surface: 4mm (Mechanical Surface Detection)
- Electronics: DAE4 Sn547; Calibrated: 2008/1/24
- Phantom: SAM1; Type: SAM 4.0; Serial: TP:1419
- Measurement SW: DASY4, V4.7 Build 71; Postprocessing SW: SEMCAD, V1.8 Build 184

Pin=250mW/Area Scan (61x61x1): Measurement grid: dx=15mm, dy=15mm
Maximum value of SAR (interpolated) = 2.58 mW/g

Pin=250mW/Zoom Scan (7x7x7)/Cube 0: Measurement grid: dx=5mm, dy=5mm, dz=5mm
Reference Value = 53.5 V/m; Power Drift = 0.000 dB
Peak SAR (extrapolated) = 3.64 W/kg

SAR(1 g) = 2.38 mW/g; SAR(10 g) = 1.54 mW/g
Maximum value of SAR (measured) = 2.57 mW/g

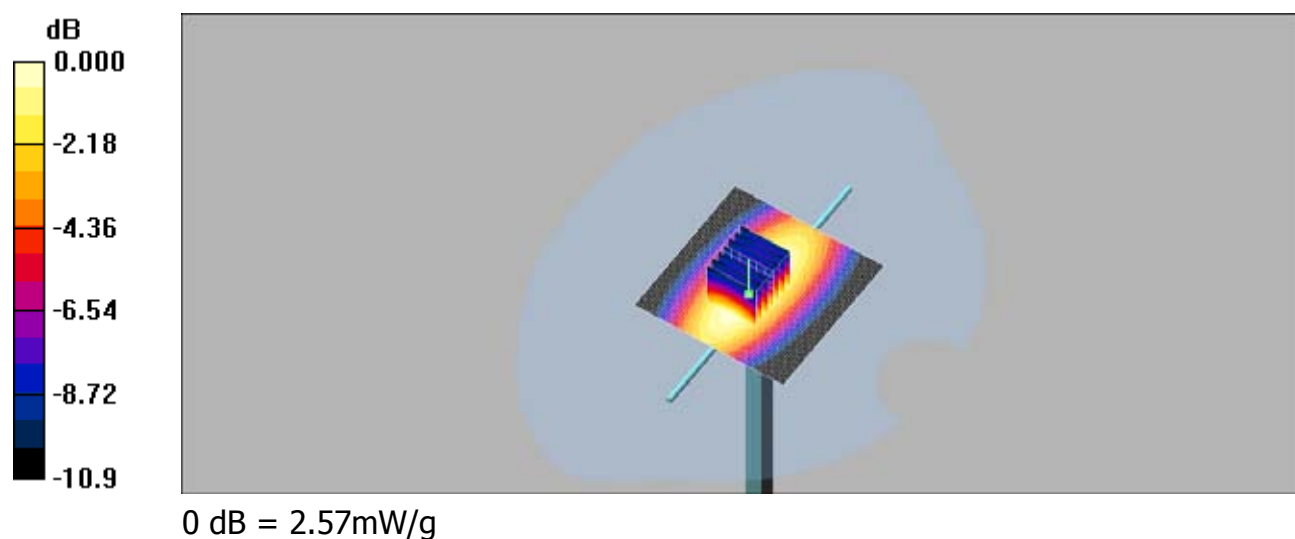

Date/Time: 2008/12/2 04:56:14

DUT: Dipole 835 MHz;

Communication System: CW; Frequency: 835 MHz; Duty Cycle: 1:1
Medium: Muscle 900 MHz Medium parameters used (interpolated): $f = 835$ MHz; $\sigma = 0.943$ mho/m; $\epsilon_r = 54.2$; $\rho = 1000$ kg/m³
Phantom section: Flat Section

DASY4 Configuration:

- Probe: EX3DV3 - SN3526; ConvF(10.87, 10.87, 10.87); Calibrated: 2008/8/26
- Sensor-Surface: 4mm (Mechanical Surface Detection)
- Electronics: DAE4 Sn547; Calibrated: 2008/1/24
- Phantom: SAM1; Type: SAM 4.0; Serial: TP:1419
- Measurement SW: DASY4, V4.7 Build 71; Postprocessing SW: SEMCAD, V1.8 Build 184

Pin=250mW/Area Scan (61x61x1): Measurement grid: dx=15mm, dy=15mm
Maximum value of SAR (interpolated) = 2.90 mW/g

Pin=250mW/Zoom Scan (7x7x7)/Cube 0: Measurement grid: dx=5mm, dy=5mm, dz=5mm

Reference Value = 55.8 V/m; Power Drift = -0.008 dB

Peak SAR (extrapolated) = 3.98 W/kg

SAR(1 g) = 2.53 mW/g; SAR(10 g) = 1.67 mW/g

Maximum value of SAR (measured) = 2.88 mW/g

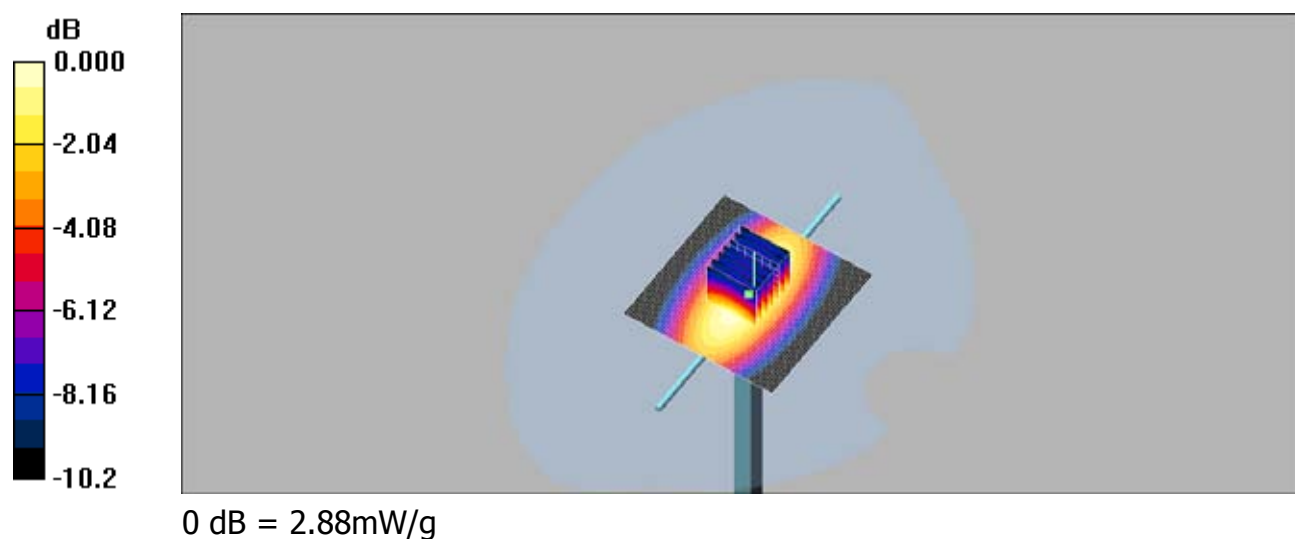

Date/Time: 2008/12/2 07:09:01

DUT: Dipole 1900 MHz;

Communication System: CW; Frequency: 1900 MHz; Duty Cycle: 1:1
Medium: Head 1900MHz Medium parameters used: $f = 1900$ MHz; $\sigma = 1.42$ mho/m; $\epsilon_r = 41.3$; $\rho = 1000$ kg/m³
Phantom section: Flat Section

DASY4 Configuration:

- Probe: EX3DV3 - SN3526; ConvF(9.46, 9.46, 9.46); Calibrated: 2008/8/26
- Sensor-Surface: 4mm (Mechanical Surface Detection)
- Electronics: DAE4 Sn547; Calibrated: 2008/1/24
- Phantom: SAM1; Type: SAM 4.0; Serial: TP:1419
- Measurement SW: DASY4, V4.7 Build 71; Postprocessing SW: SEMCAD, V1.8 Build 184

Pin=250mw/Area Scan (51x61x1): Measurement grid: dx=15mm, dy=15mm
Maximum value of SAR (interpolated) = 13.1 mW/g

Pin=250mw/Zoom Scan (7x7x7)/Cube 0: Measurement grid: dx=5mm, dy=5mm, dz=5mm

Reference Value = 89.8 V/m; Power Drift = -0.013 dB

Peak SAR (extrapolated) = 19.3 W/kg

SAR(1 g) = 10.1 mW/g; SAR(10 g) = 5.13 mW/g

Maximum value of SAR (measured) = 11.2 mW/g

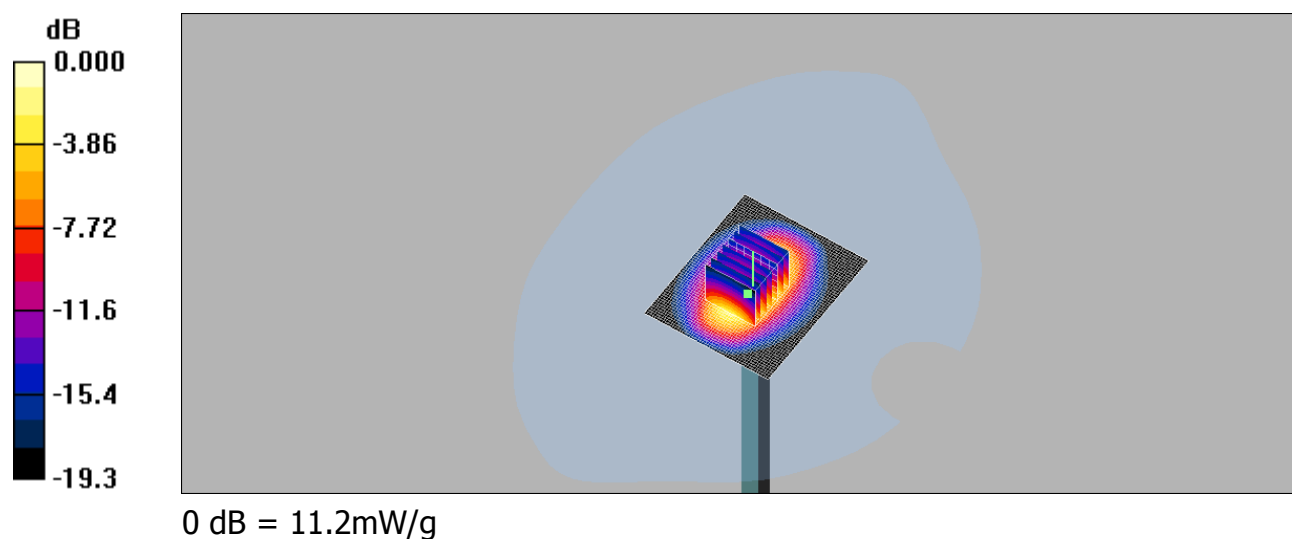

Date/Time: 2008/12/2 09:48:28

DUT: Dipole 1900 MHz;

Communication System: CW; Frequency: 1900 MHz; Duty Cycle: 1:1
Medium: M1800 & 1900 Medium parameters used: $f = 1900$ MHz; $\sigma = 1.58$ mho/m; $\epsilon_r = 51.1$;
 $\rho = 1000$ kg/m³
Phantom section: Flat Section

DASY4 Configuration:

- Probe: EX3DV3 - SN3526; ConvF(9.28, 9.28, 9.28); Calibrated: 2008/8/26
- Sensor-Surface: 4mm (Mechanical Surface Detection)
- Electronics: DAE4 Sn547; Calibrated: 2008/1/24
- Phantom: SAM1; Type: SAM 4.0; Serial: TP:1419
- Measurement SW: DASY4, V4.7 Build 71; Postprocessing SW: SEMCAD, V1.8 Build 184

Pin=250mW/Area Scan (51x61x1): Measurement grid: dx=15mm, dy=15mm
Maximum value of SAR (interpolated) = 12.8 mW/g

Pin=250mW/Zoom Scan (7x7x7)/Cube 0: Measurement grid: dx=5mm, dy=5mm, dz=5mm
Reference Value = 83.3 V/m; Power Drift = -0.023 dB
Peak SAR (extrapolated) = 17.9 W/kg

SAR(1 g) = 9.79 mW/g; SAR(10 g) = 5.12 mW/g
Maximum value of SAR (measured) = 11.1 mW/g

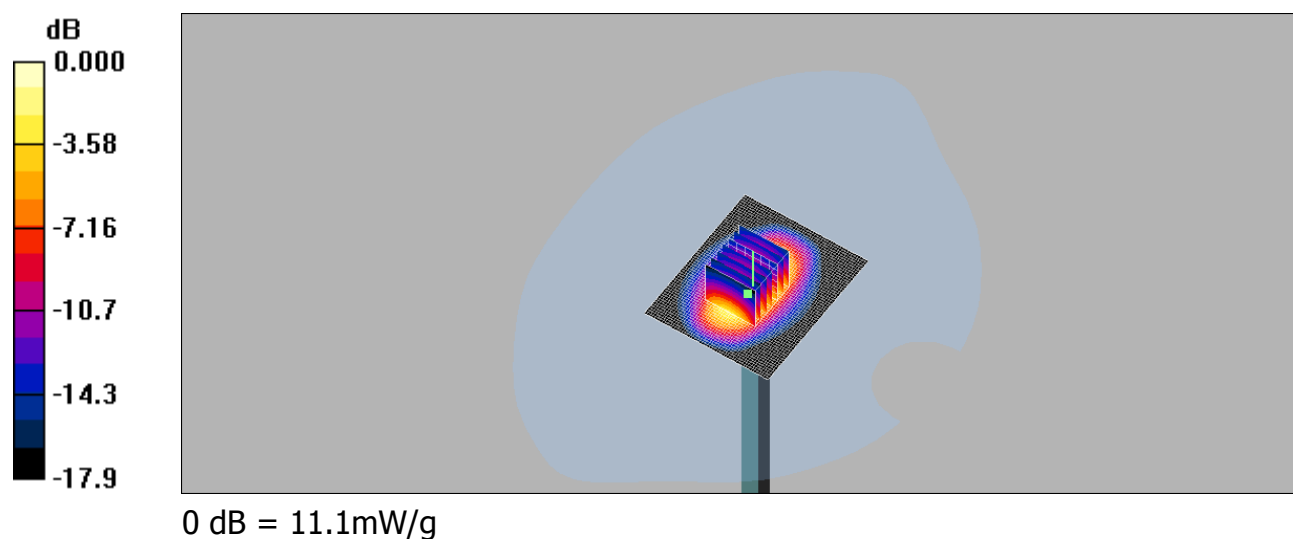

Date/Time: 2008/12/2 12:16:37

DUT: Dipole 2450 MHz;

Communication System: CW; Frequency: 2450 MHz; Duty Cycle: 1:1

Medium: M 2450 Medium parameters used: $f = 2450$ MHz; $\sigma = 2.05$ mho/m; $\epsilon_r = 53$; $\rho = 1000$ kg/m³

Phantom section: Flat Section

DASY4 Configuration:

- Probe: EX3DV3 - SN3526; ConvF(8.18, 8.18, 8.18); Calibrated: 2008/8/26
- Sensor-Surface: 4mm (Mechanical Surface Detection)
- Electronics: DAE4 Sn547; Calibrated: 2008/1/24
- Phantom: SAM1; Type: SAM 4.0; Serial: TP:1419
- Measurement SW: DASY4, V4.7 Build 71; Postprocessing SW: SEMCAD, V1.8 Build 184

Pin=250mW/Area Scan (51x61x1): Measurement grid: dx=15mm, dy=15mm
Maximum value of SAR (interpolated) = 18.5 mW/g

Pin=250mW/Zoom Scan (7x7x7)/Cube 0: Measurement grid: dx=5mm, dy=5mm, dz=5mm

Reference Value = 85.0 V/m; Power Drift = -0.026 dB

Peak SAR (extrapolated) = 28.6 W/kg

SAR(1 g) = 13.7 mW/g; SAR(10 g) = 6.25 mW/g

Maximum value of SAR (measured) = 15.6 mW/g

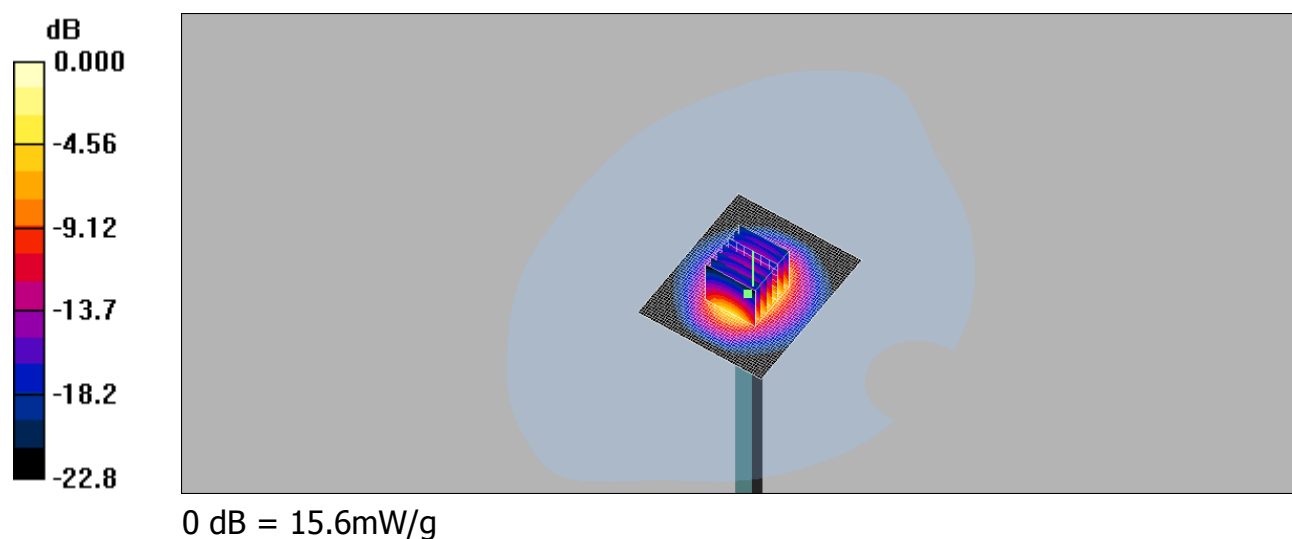

Date/Time: 2009/01/10 08:39:09

DUT: Dipole 835 MHz;

Communication System: CW; Frequency: 835 MHz; Duty Cycle: 1:1
Medium: Head 900 MHz Medium parameters used: $f = 835$ MHz; $\sigma = 0.897$ mho/m; $\epsilon_r = 42.2$;
 $\rho = 1000$ kg/m³
Phantom section: Flat Section

DASY4 Configuration:

- Probe: EX3DV3 - SN3526; ConvF(10.93, 10.93, 10.93); Calibrated: 2008/8/26
- Sensor-Surface: 4mm (Mechanical Surface Detection)
- Electronics: DAE4 Sn547; Calibrated: 2008/1/24
- Phantom: SAM1; Type: SAM 4.0; Serial: TP:1419
- Measurement SW: DASY4, V4.7 Build 71; Postprocessing SW: SEMCAD, V1.8 Build 184

Pin=250mW/Area Scan (61x61x1): Measurement grid: dx=15mm, dy=15mm
Maximum value of SAR (interpolated) = 2.57 mW/g

Pin=250mW/Zoom Scan (7x7x7)/Cube 0: Measurement grid: dx=5mm, dy=5mm, dz=5mm
Reference Value = 53.4 V/m; Power Drift = -0.007 dB
Peak SAR (extrapolated) = 3.65 W/kg

SAR(1 g) = 2.38 mW/g; SAR(10 g) = 1.54 mW/g
Maximum value of SAR (measured) = 2.57 mW/g

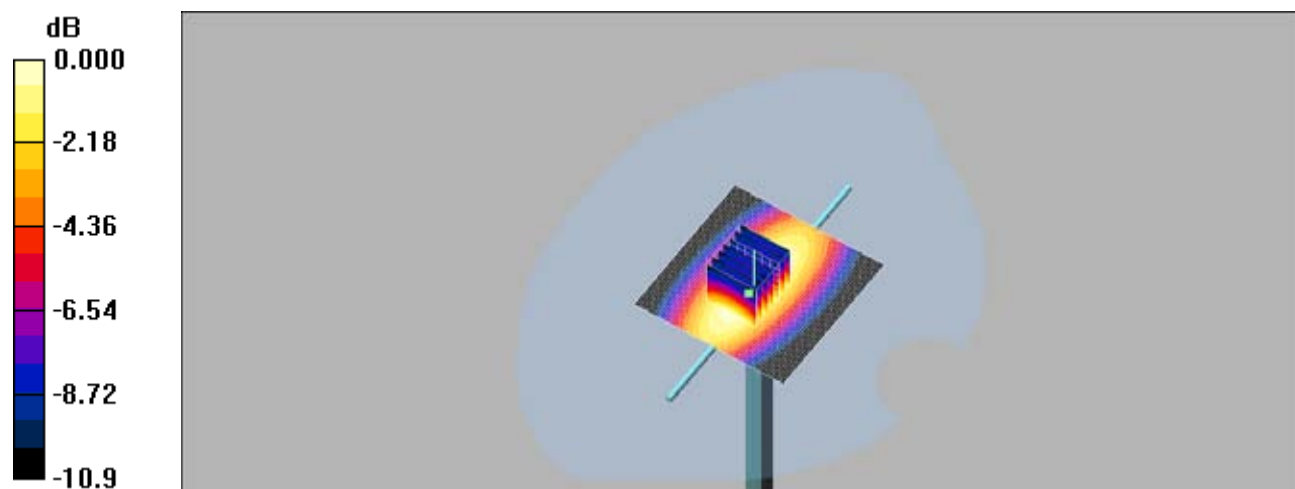

0 dB = 2.57mW/g

Date/Time: 2009/01/11 08:40:20

DUT: Dipole 835 MHz;

Communication System: CW; Frequency: 835 MHz; Duty Cycle: 1:1

Medium: Muscle 900 MHz Medium parameters used (interpolated): $f = 835$ MHz; $\sigma = 0.946$ mho/m; $\epsilon_r = 54.3$; $\rho = 1000$ kg/m³

Phantom section: Flat Section

DASY4 Configuration:

- Probe: EX3DV3 - SN3526; ConvF(10.87, 10.87, 10.87); Calibrated: 2008/8/26
- Sensor-Surface: 4mm (Mechanical Surface Detection)
- Electronics: DAE4 Sn547; Calibrated: 2008/1/24
- Phantom: SAM1; Type: SAM 4.0; Serial: TP:1419
- Measurement SW: DASY4, V4.7 Build 71; Postprocessing SW: SEMCAD, V1.8 Build 184

Pin=250mW/Area Scan (61x61x1): Measurement grid: dx=15mm, dy=15mm
Maximum value of SAR (interpolated) = 2.55 mW/g

Pin=250mW/Zoom Scan (7x7x7)/Cube 0: Measurement grid: dx=5mm, dy=5mm, dz=5mm
Reference Value = 52.3 V/m; Power Drift = -0.021 dB
Peak SAR (extrapolated) = 3.48 W/kg

SAR(1 g) = 2.36 mW/g; SAR(10 g) = 1.57 mW/g
Maximum value of SAR (measured) = 2.55 mW/g

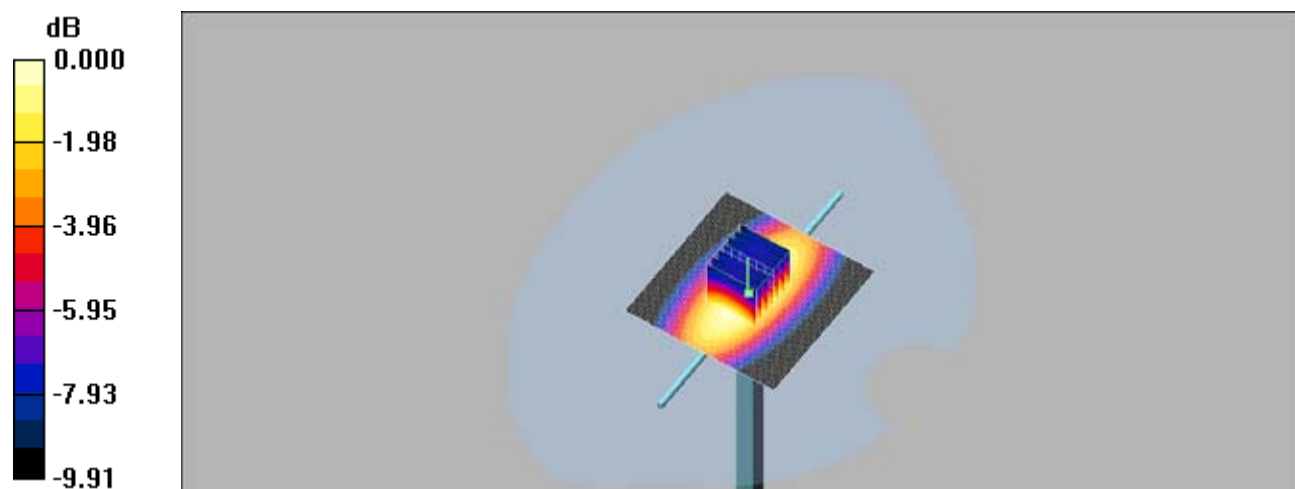

0 dB = 2.55mW/g

Date/Time: 2009/01/10 12:36:17

DUT: Dipole 1900 MHz;

Communication System: CW; Frequency: 1900 MHz; Duty Cycle: 1:1
Medium: Head 1900MHz Medium parameters used: $f = 1900$ MHz; $\sigma = 1.43$ mho/m; $\epsilon_r = 41.4$; $\rho = 1000$ kg/m³
Phantom section: Flat Section

DASY4 Configuration:

- Probe: EX3DV3 - SN3526; ConvF(9.46, 9.46, 9.46); Calibrated: 2008/8/26
- Sensor-Surface: 4mm (Mechanical Surface Detection)
- Electronics: DAE4 Sn547; Calibrated: 2008/1/24
- Phantom: SAM1; Type: SAM 4.0; Serial: TP:1419
- Measurement SW: DASY4, V4.7 Build 71; Postprocessing SW: SEMCAD, V1.8 Build 184

Pin=250mw/Area Scan (51x61x1): Measurement grid: dx=15mm, dy=15mm
Maximum value of SAR (interpolated) = 12.8 mW/g

Pin=250mw/Zoom Scan (7x7x7)/Cube 0: Measurement grid: dx=5mm, dy=5mm, dz=5mm
Reference Value = 86.0 V/m; Power Drift = -0.016 dB
Peak SAR (extrapolated) = 20.0 W/kg

SAR(1 g) = 10.5 mW/g; SAR(10 g) = 5.4 mW/g
Maximum value of SAR (measured) = 11.6 mW/g

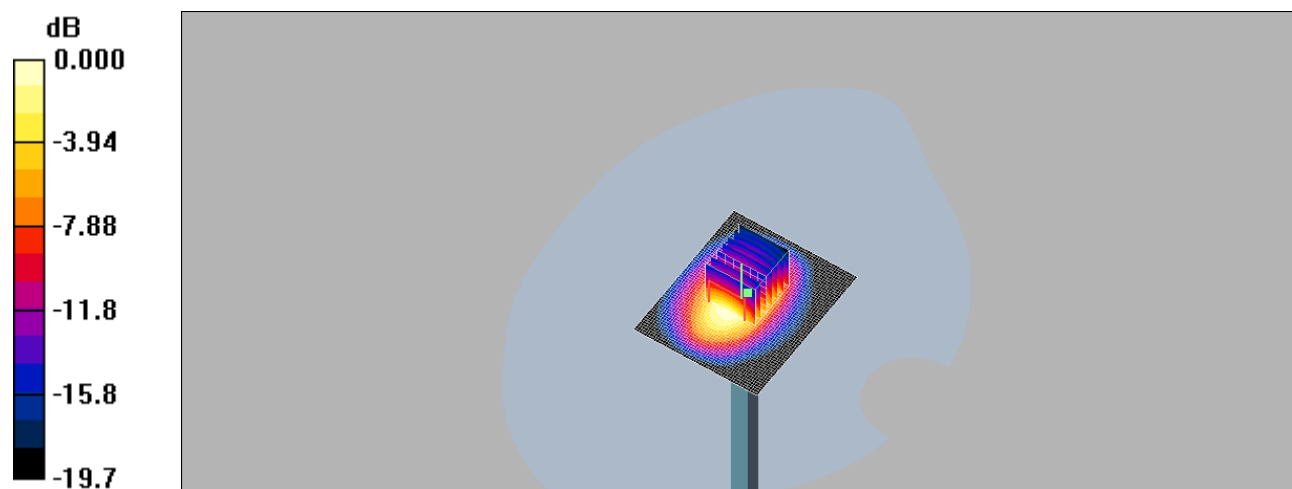

0 dB = 11.6mW/g

Date/Time: 2009/01/11 13:21:28

DUT: Dipole 1900 MHz;

Communication System: CW; Frequency: 1900 MHz; Duty Cycle: 1:1
Medium: M1800 & 1900 Medium parameters used: $f = 1900$ MHz; $\sigma = 1.57$ mho/m; $\epsilon_r = 51.1$;
 $\rho = 1000$ kg/m³
Phantom section: Flat Section

DASY4 Configuration:

- Probe: EX3DV3 - SN3526; ConvF(9.28, 9.28, 9.28); Calibrated: 2008/8/26
- Sensor-Surface: 4mm (Mechanical Surface Detection)
- Electronics: DAE4 Sn547; Calibrated: 2008/1/24
- Phantom: SAM1; Type: SAM 4.0; Serial: TP:1419
- Measurement SW: DASY4, V4.7 Build 71; Postprocessing SW: SEMCAD, V1.8 Build 184

Pin=250mW/Area Scan (51x61x1): Measurement grid: dx=15mm, dy=15mm
Maximum value of SAR (interpolated) = 12.3 mW/g

Pin=250mW/Zoom Scan (7x7x7)/Cube 0: Measurement grid: dx=5mm, dy=5mm, dz=5mm
Reference Value = 83.4 V/m; Power Drift = -0.190 dB
Peak SAR (extrapolated) = 17.2 W/kg

SAR(1 g) = 9.29 mW/g; SAR(10 g) = 4.78 mW/g
Maximum value of SAR (measured) = 10.3 mW/g

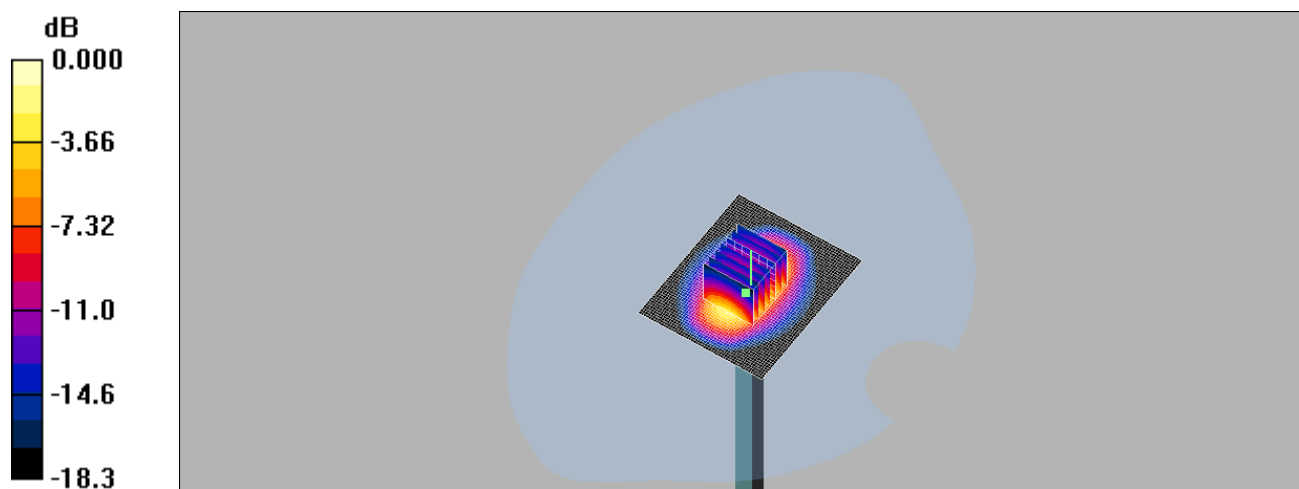

0 dB = 10.3mW/g

Date/Time: 2009/01/11 18:36:04

DUT: Dipole 2450 MHz;

Communication System: CW; Frequency: 2450 MHz; Duty Cycle: 1:1

Medium: M 2450 Medium parameters used: $f = 2450$ MHz; $\sigma = 2.03$ mho/m; $\epsilon_r = 51.2$; $\rho = 1000$ kg/m³

Phantom section: Flat Section

DASY4 Configuration:

- Probe: EX3DV3 - SN3526; ConvF(8.18, 8.18, 8.18); Calibrated: 2008/8/26
- Sensor-Surface: 4mm (Mechanical Surface Detection)
- Electronics: DAE4 Sn547; Calibrated: 2008/1/24
- Phantom: SAM1; Type: SAM 4.0; Serial: TP:1419
- Measurement SW: DASY4, V4.7 Build 71; Postprocessing SW: SEMCAD, V1.8 Build 184

Pin=250mW/Area Scan (51x61x1): Measurement grid: dx=15mm, dy=15mm
Maximum value of SAR (interpolated) = 18.9 mW/g

Pin=250mW/Zoom Scan (7x7x7)/Cube 0: Measurement grid: dx=5mm, dy=5mm, dz=5mm
Reference Value = 86.1 V/m; Power Drift = -0.048 dB
Peak SAR (extrapolated) = 28.8 W/kg

SAR(1 g) = 13.8 mW/g; SAR(10 g) = 6.34 mW/g
Maximum value of SAR (measured) = 15.7 mW/g

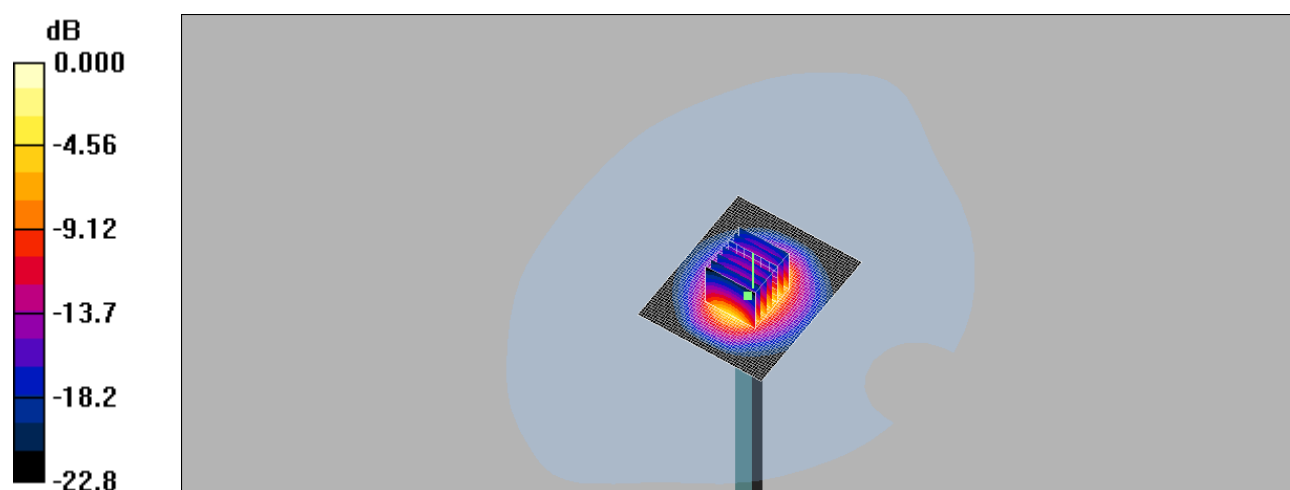

0 dB = 15.7mW/g

6. DAE & Probe Calibration certificate

Calibration Laboratory of
 Schmid & Partner
 Engineering AG
 Zeughausstrasse 43, 8004 Zurich, Switzerland



S Schweizerischer Kalibrierdienst
 C Service suisse d'étalonnage
 S Servizio svizzero di taratura
 S Swiss Calibration Service

Accredited by the Swiss Accreditation Service (SAS)
 The Swiss Accreditation Service is one of the signatories to the EA
 Multilateral Agreement for the recognition of calibration certificates

Accreditation No.: SCS 108

Client **SGS (Auden)**

Certificate No: DAE4-547_Jan08

CALIBRATION CERTIFICATE

Object: **DAE4 - SD 000 D04 BA - SN: 547**

Calibration procedure(s): **QA CAL-06.v12
 Calibration procedure for the data acquisition electronics (DAE)**

Calibration date: **January 24, 2008**

Condition of the calibrated item: **In Tolerance**

This calibration certificate documents the traceability to national standards, which realize the physical units of measurements (SI).
 The measurements and the uncertainties with confidence probability are given on the following pages and are part of the certificate.

All calibrations have been conducted in the closed laboratory facility: environment temperature (22 ± 3)°C and humidity < 70%.

Calibration Equipment used (M&TE critical for calibration)

Primary Standards	ID #	Cal Date (Calibrated by, Certificate No.)	Scheduled Calibration
Fluke Process Calibrator Type 702	SN: 6295803	04-Oct-07 (Eical AG, No: 6467)	Oct-08
Keithley Multimeter Type 2001	SN: 0810275	03-Oct-07 (Eical AG, No: 6465)	Oct-08
Secondary Standards	ID #	Check Date (in house)	Scheduled Check
Calibrator Box V1.1	SE LMS 006 AB 1004	25-Jun-07 (SPEAG, In house check)	In house check Jun-08

	Name	Function	Signature
Calibrated by:	Daniel Hess	Technician	<i>D. Hess</i>
Approved by:	Fin Bornholt	R&D Director	<i>Fin Bornholt</i>

Issued: January 24, 2008

This calibration certificate shall not be reproduced except in full without written approval of the laboratory.

**Calibration Laboratory of
 Schmid & Partner
 Engineering AG**
 Zeughausstrasse 43, 8004 Zurich, Switzerland



S Schweizerischer Kalibrierdienst
C Service suisse d'étalonnage
S Servizio svizzero di taratura
S Swiss Calibration Service

Accredited by the Swiss Accreditation Service (SAS)
 The Swiss Accreditation Service is one of the signatories to the EA
 Multilateral Agreement for the recognition of calibration certificates

Accreditation No.: **SCS 108**

Client **SGS (Auden)**

Certificate No: **EX3-3526_Aug08**

CALIBRATION CERTIFICATE

Object **EX3DV3 - SN:3526**

Calibration procedure(s) **QA CAL-01.v6, QA CAL-14.v3 and QA CAL-23.v3
 Calibration procedure for dosimetric E-field probes**

Calibration date: **August 26, 2008**

Condition of the calibrated item **In Tolerance**

This calibration certificate documents the traceability to national standards, which realize the physical units of measurements (SI).
 The measurements and the uncertainties with confidence probability are given on the following pages and are part of the certificate.

All calibrations have been conducted in the closed laboratory facility: environment temperature (22 ± 3)°C and humidity < 70%.

Calibration Equipment used (M&TE critical for calibration)

Primary Standards	ID #	Cal Date (Certificate No.)	Scheduled Calibration
Power meter E4419B	GB41293874	1-Apr-08 (No. 217-00788)	Apr-09
Power sensor E4412A	MY41495277	1-Apr-08 (No. 217-00788)	Apr-09
Power sensor E4412A	MY41498087	1-Apr-08 (No. 217-00788)	Apr-09
Reference 3 dB Attenuator	SN: S5054 (3c)	1-Jul-08 (No. 217-00865)	Jul-09
Reference 20 dB Attenuator	SN: S5086 (20b)	31-Mar-08 (No. 217-00787)	Apr-09
Reference 30 dB Attenuator	SN: S5129 (30b)	1-Jul-08 (No. 217-00866)	Jul-09
Reference Probe ES3DV2	SN: 3013	2-Jan-08 (No. ES3-3013_Jan08)	Jan-09
DAE4	SN: 660	3-Sep-07 (No. DAE4-660_Sep07)	Sep-08

Secondary Standards	ID #	Check Date (in house)	Scheduled Check
RF generator HP 8648C	US3642U01700	4-Aug-99 (in house check Oct-07)	In house check: Oct-09
Network Analyzer HP 8753E	US37390585	18-Oct-01 (in house check Oct-07)	In house check: Oct-08

	Name	Function	Signature
Calibrated by:	Katja Pokovic	Technical Manager	
Approved by:	Niels Kuster	Quality Manager	

Issued: August 26, 2008

This calibration certificate shall not be reproduced except in full without written approval of the laboratory.

Calibration Laboratory of
Schmid & Partner
Engineering AG
Zeughausstrasse 43, 8004 Zurich, Switzerland



S Schweizerischer Kalibrierdienst
C Service suisse d'étalonnage
S Servizio svizzero di taratura
S Swiss Calibration Service

Accredited by the Swiss Accreditation Service (SAS)
The Swiss Accreditation Service is one of the signatories to the EA
Multilateral Agreement for the recognition of calibration certificates

Accreditation No.: **SCS 108**

Glossary:

TSL	tissue simulating liquid
NORM _{x,y,z}	sensitivity in free space
ConvF	sensitivity in TSL / NORM _{x,y,z}
DCP	diode compression point
Polarization φ	φ rotation around probe axis
Polarization ϑ	ϑ rotation around an axis that is in the plane normal to probe axis (at measurement center), i.e., $\vartheta = 0$ is normal to probe axis

Calibration is Performed According to the Following Standards:

- IEEE Std 1528-2003, "IEEE Recommended Practice for Determining the Peak Spatial-Averaged Specific Absorption Rate (SAR) in the Human Head from Wireless Communications Devices: Measurement Techniques", December 2003
- IEC 62209-1, "Procedure to measure the Specific Absorption Rate (SAR) for hand-held devices used in close proximity to the ear (frequency range of 300 MHz to 3 GHz)", February 2005

Methods Applied and Interpretation of Parameters:

- NORM_{x,y,z}**: Assessed for E-field polarization $\vartheta = 0$ ($f \leq 900$ MHz in TEM-cell; $f > 1800$ MHz: R22 waveguide). NORM_{x,y,z} are only intermediate values, i.e., the uncertainties of NORM_{x,y,z} does not effect the E²-field uncertainty inside TSL (see below ConvF).
- NORM(f)_{x,y,z} = NORM_{x,y,z} * frequency_response** (see Frequency Response Chart). This linearization is implemented in DASY4 software versions later than 4.2. The uncertainty of the frequency response is included in the stated uncertainty of ConvF.
- DCP_{x,y,z}**: DCP are numerical linearization parameters assessed based on the data of power sweep (no uncertainty required). DCP does not depend on frequency nor media.
- ConvF and Boundary Effect Parameters**: Assessed in flat phantom using E-field (or Temperature Transfer Standard for $f \leq 800$ MHz) and inside waveguide using analytical field distributions based on power measurements for $f > 800$ MHz. The same setups are used for assessment of the parameters applied for boundary compensation (alpha, depth) of which typical uncertainty values are given. These parameters are used in DASY4 software to improve probe accuracy close to the boundary. The sensitivity in TSL corresponds to NORM_{x,y,z} * ConvF whereby the uncertainty corresponds to that given for ConvF. A frequency dependent ConvF is used in DASY version 4.4 and higher which allows extending the validity from ± 50 MHz to ± 100 MHz.
- Spherical isotropy (3D deviation from isotropy)**: in a field of low gradients realized using a flat phantom exposed by a patch antenna.
- Sensor Offset**: The sensor offset corresponds to the offset of virtual measurement center from the probe tip (on probe axis). No tolerance required.

EX3DV3 SN:3526

August 26, 2008

Probe EX3DV3

SN:3526

Manufactured:	March 19, 2004
Last calibrated:	August 29, 2007
Recalibrated:	August 26, 2008

Calibrated for DASY Systems

(Note: non-compatible with DASY2 system!)

EX3DV3 SN:3526

August 26, 2008

Frequency Response of E-Field

(TEM-Cell:ifi110 EXX, Waveguide: R22)

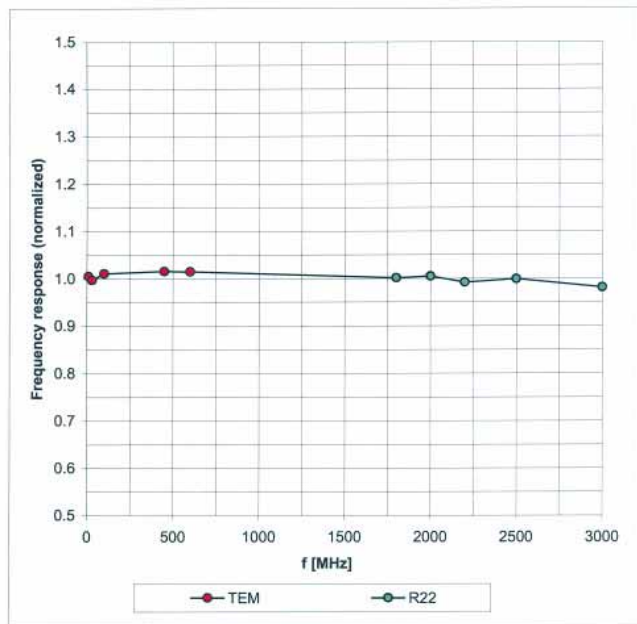

Uncertainty of Frequency Response of E-field: $\pm 6.3\%$ ($k=2$)

EX3DV3 SN:3526

August 26, 2008

Receiving Pattern (ϕ), $\vartheta = 0^\circ$

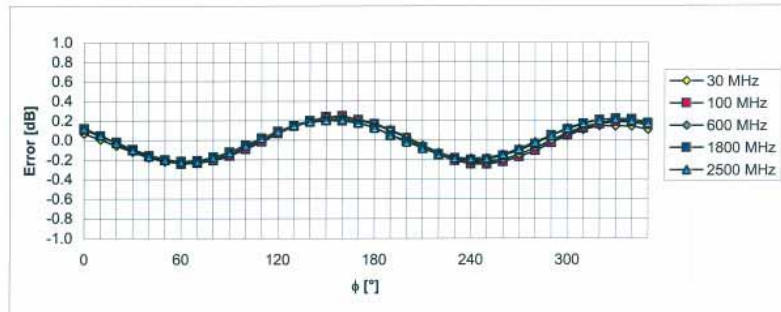
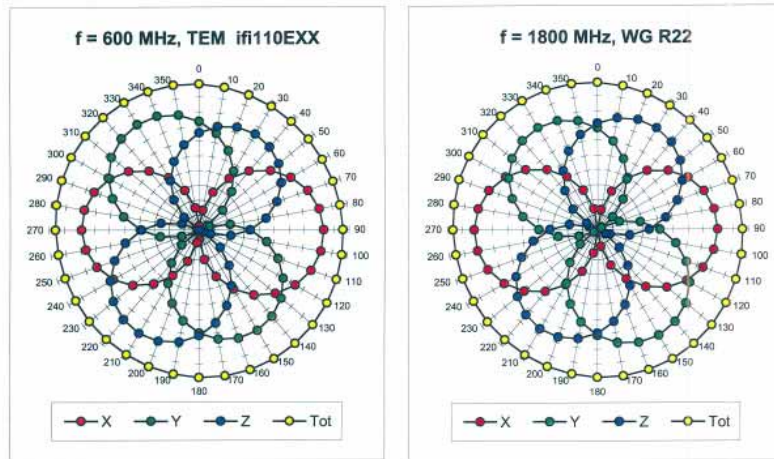

Uncertainty of Axial Isotropy Assessment: $\pm 0.5\%$ ($k=2$)

EX3DV3 SN:3526

August 26, 2008

Dynamic Range $f(\text{SAR}_{\text{head}})$ (Waveguide R22, $f = 1800$ MHz)

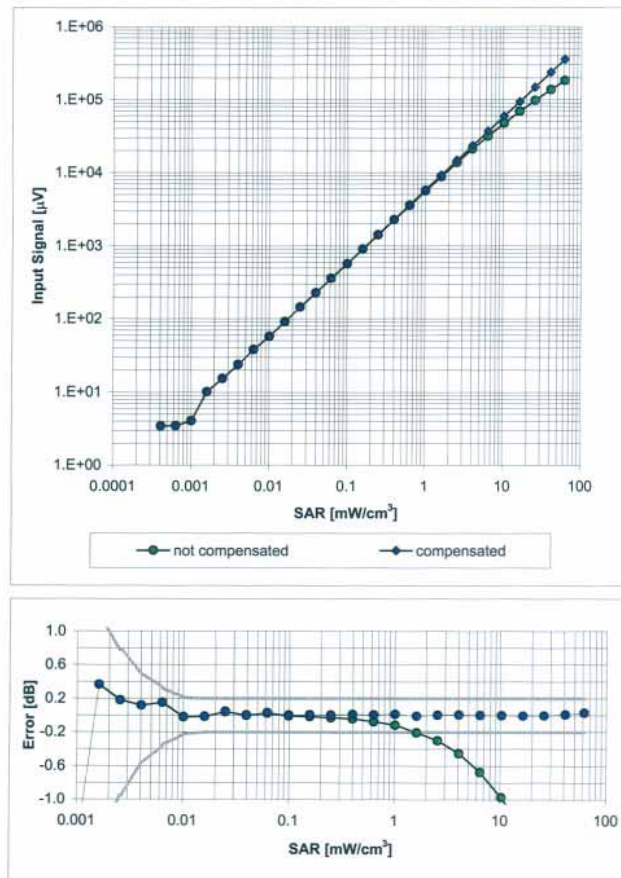

Uncertainty of Linearity Assessment: $\pm 0.6\%$ ($k=2$)

EX3DV3 SN:3526

August 26, 2008

Conversion Factor Assessment

f [MHz]	Validity [MHz] ^c	TSL	Permittivity	Conductivity	Alpha	Depth	ConvF Uncertainty
900	± 50 / ± 100	Head	41.5 ± 5%	0.97 ± 5%	0.54	0.76	10.93 ± 11.0% (k=2)
1810	± 50 / ± 100	Head	40.0 ± 5%	1.40 ± 5%	0.52	0.68	9.46 ± 11.0% (k=2)
1950	± 50 / ± 100	Head	40.0 ± 5%	1.40 ± 5%	0.58	0.61	9.15 ± 11.0% (k=2)
2450	± 50 / ± 100	Head	39.2 ± 5%	1.80 ± 5%	0.42	0.74	8.49 ± 11.0% (k=2)
2600	± 50 / ± 100	Head	39.0 ± 5%	1.96 ± 5%	0.42	0.75	8.53 ± 11.0% (k=2)
3500	± 50 / ± 100	Head	37.9 ± 5%	2.91 ± 5%	0.30	1.20	8.15 ± 13.1% (k=2)
5200	± 50 / ± 100	Head	36.0 ± 5%	4.66 ± 5%	0.40	1.65	5.68 ± 13.1% (k=2)
5500	± 50 / ± 100	Head	35.6 ± 5%	4.96 ± 5%	0.40	1.65	5.01 ± 13.1% (k=2)
5800	± 50 / ± 100	Head	35.3 ± 5%	5.27 ± 5%	0.40	1.65	4.90 ± 13.1% (k=2)
900	± 50 / ± 100	Body	55.0 ± 5%	1.05 ± 5%	0.66	0.68	10.87 ± 11.0% (k=2)
1810	± 50 / ± 100	Body	53.3 ± 5%	1.52 ± 5%	0.50	0.74	9.28 ± 11.0% (k=2)
1950	± 50 / ± 100	Body	53.3 ± 5%	1.52 ± 5%	0.45	0.78	9.17 ± 11.0% (k=2)
2450	± 50 / ± 100	Body	52.7 ± 5%	1.95 ± 5%	0.44	0.80	8.18 ± 11.0% (k=2)
2600	± 50 / ± 100	Body	52.5 ± 5%	2.16 ± 5%	0.47	0.76	8.14 ± 11.0% (k=2)
3500	± 50 / ± 100	Body	51.3 ± 5%	3.31 ± 5%	0.30	1.20	7.36 ± 13.1% (k=2)
5200	± 50 / ± 100	Body	49.0 ± 5%	5.30 ± 5%	0.40	1.70	4.89 ± 13.1% (k=2)
5500	± 50 / ± 100	Body	48.6 ± 5%	5.65 ± 5%	0.40	1.70	4.39 ± 13.1% (k=2)
5800	± 50 / ± 100	Body	48.2 ± 5%	6.00 ± 5%	0.40	1.70	4.44 ± 13.1% (k=2)

^c The validity of ± 100 MHz only applies for DASY v4.4 and higher (see Page 2). The uncertainty is the RSS of the ConvF uncertainty at calibration frequency and the uncertainty for the indicated frequency band.

EX3DV3 SN:3526

August 26, 2008

Deviation from Isotropy in HSL

Error (ϕ , θ), $f = 900$ MHz

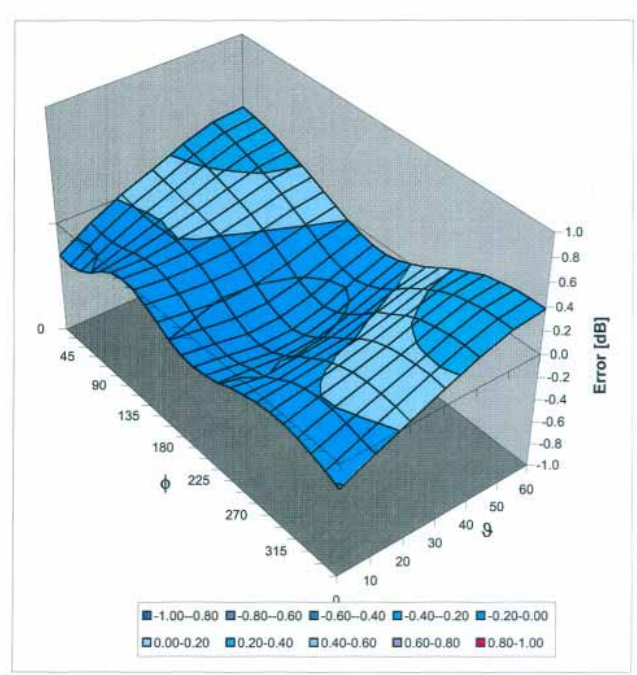

Uncertainty of Spherical Isotropy Assessment: $\pm 2.6\%$ ($k=2$)

7. Uncertainty Analysis

DASY4 Uncertainty Budget According to IEEE P1528 [1]								
Error Description	Uncertainty value	Prob. Dist.	Div.	(c_i) 1g	(c_i) 10g	Std. Unc. (1g)	Std. Unc. (10g)	(v_i) v_{eff}
Measurement System								
Probe Calibration	±4.8 %	N	1	1	1	±4.8 %	±4.8 %	∞
Axial Isotropy	±4.7 %	R	$\sqrt{3}$	0.7	0.7	±1.9 %	±1.9 %	∞
Hemispherical Isotropy	±9.6 %	R	$\sqrt{3}$	0.7	0.7	±3.9 %	±3.9 %	∞
Boundary Effects	±1.0 %	R	$\sqrt{3}$	1	1	±0.6 %	±0.6 %	∞
Linearity	±4.7 %	R	$\sqrt{3}$	1	1	±2.7 %	±2.7 %	∞
System Detection Limits	±1.0 %	R	$\sqrt{3}$	1	1	±0.6 %	±0.6 %	∞
Readout Electronics	±1.0 %	N	1	1	1	±1.0 %	±1.0 %	∞
Response Time	±0.8 %	R	$\sqrt{3}$	1	1	±0.5 %	±0.5 %	∞
Integration Time	±2.6 %	R	$\sqrt{3}$	1	1	±1.5 %	±1.5 %	∞
RF Ambient Conditions	±3.0 %	R	$\sqrt{3}$	1	1	±1.7 %	±1.7 %	∞
Probe Positioner	±0.4 %	R	$\sqrt{3}$	1	1	±0.2 %	±0.2 %	∞
Probe Positioning	±2.9 %	R	$\sqrt{3}$	1	1	±1.7 %	±1.7 %	∞
Max. SAR Eval.	±1.0 %	R	$\sqrt{3}$	1	1	±0.6 %	±0.6 %	∞
Test Sample Related								
Device Positioning	±2.9 %	N	1	1	1	±2.9 %	±2.9 %	875
Device Holder	±3.6 %	N	1	1	1	±3.6 %	±3.6 %	5
Power Drift	±5.0 %	R	$\sqrt{3}$	1	1	±2.9 %	±2.9 %	∞
Phantom and Setup								
Phantom Uncertainty	±4.0 %	R	$\sqrt{3}$	1	1	±2.3 %	±2.3 %	∞
Liquid Conductivity (target)	±5.0 %	R	$\sqrt{3}$	0.64	0.43	±1.8 %	±1.2 %	∞
Liquid Conductivity (meas.)	±2.5 %	N	1	0.64	0.43	±1.6 %	±1.1 %	∞
Liquid Permittivity (target)	±5.0 %	R	$\sqrt{3}$	0.6	0.49	±1.7 %	±1.4 %	∞
Liquid Permittivity (meas.)	±2.5 %	N	1	0.6	0.49	±1.5 %	±1.2 %	∞
Combined Std. Uncertainty						±10.3 %	±10.0 %	331
Expanded STD Uncertainty						±20.6 %	±20.1 %	

8. Phantom description

Schmid & Partner Engineering AG

s p e a g

Zeughausstrasse 43, 8004 Zurich, Switzerland
Phone +41 1 245 9700, Fax +41 1 245 9779
info@speag.com, http://www.speag.com

Certificate of Conformity / First Article Inspection

Item	SAM Twin Phantom V4.0
Type No	QD 000 P40 C
Series No	TP-1150 and higher
Manufacturer	SPEAG Zeughausstrasse 43 CH-8004 Zurich Switzerland

Tests

The series production process used allows the limitation to test of first articles.
Complete tests were made on the pre-series Type No. QD 000 P40 AA, Serial No. TP-1001 and on the series first article Type No. QD 000 P40 BA, Serial No. TP-1006. Certain parameters have been retested using further series items (called samples) or are tested at each item.

Test	Requirement	Details	Units tested
Dimensions	Compliant with the geometry according to the CAD model.	IT'IS CAD File (*)	First article, Samples
Material thickness of shell	Compliant with the requirements according to the standards	2mm +/- 0.2mm in flat and specific areas of head section	First article, Samples, TP-1314 ff.
Material thickness at ERP	Compliant with the requirements according to the standards	6mm +/- 0.2mm at ERP	First article, All items
Material parameters	Dielectric parameters for required frequencies	300 MHz – 6 GHz: Relative permittivity < 5, Loss tangent < 0.05	Material samples
Material resistivity	The material has been tested to be compatible with the liquids defined in the standards if handled and cleaned according to the instructions. Observe technical Note for material compatibility.	DEGMBE based simulating liquids	Pre-series, First article, Material samples
Sagging	Compliant with the requirements according to the standards. Sagging of the flat section when filled with tissue simulating liquid.	< 1% typical < 0.8% if filled with 155mm of HSL900 and without DUT below	Prototypes, Sample testing

Standards

- [1] CENELEC EN 50361
- [2] IEEE Std 1528-2003
- [3] IEC 62209 Part I
- [4] FCC OET Bulletin 65, Supplement C, Edition 01-01

(*) The IT'IS CAD file is derived from [2] and is also within the tolerance requirements of the shapes of the other documents.

Conformity

Based on the sample tests above, we certify that this item is in compliance with the uncertainty requirements of SAR measurements specified in standards [1] to [4].

Date 07.07.2005

Signature / Stamp

s p e a g

Schmid & Partner Engineering AG
Zeughausstrasse 43, 8004 Zurich, Switzerland
Phone +41 1 245 9700, Fax +41 1 245 9779
info@speag.com, http://www.speag.com

9. System Validation from Original equipment supplier

**Calibration Laboratory of
Schmid & Partner
Engineering AG**
Zeughausstrasse 43, 8004 Zurich, Switzerland



S Schweizerischer Kalibrierdienst
C Service suisse d'étalonnage
S Servizio svizzero di taratura
S Swiss Calibration Service

Accredited by the Swiss Accreditation Service (SAS)
The Swiss Accreditation Service is one of the signatories to the EA
Multilateral Agreement for the recognition of calibration certificates

Accreditation No.: **SCS 108**

Client **SGS (Auden)**

Certificate No.: **D835V2-4d063_Jun08**

CALIBRATION CERTIFICATE

Object: **D835V2 - SN: 4d063**

Calibration procedure(s): **QA CAL-05.v7
Calibration procedure for dipole validation kits**

Calibration date: **June 06, 2008**

Condition of the calibrated item: **In Tolerance**

This calibration certificate documents the traceability to national standards, which realize the physical units of measurements (SI).
The measurements and the uncertainties with confidence probability are given on the following pages and are part of the certificate.

All calibrations have been conducted in the closed laboratory facility: environment temperature (22 ± 3)°C and humidity < 70%.

Calibration Equipment used (M&TE critical for calibration)

Primary Standards	ID #	Cal Date (Calibrated by, Certificate No.)	Scheduled Calibration
Power meter EPM-442A	GB37480704	04-Oct-07 (METAS, No. 217-00736)	Oct-08
Power sensor HP 8481A	US37282783	04-Oct-07 (METAS, No. 217-00736)	Oct-08
Reference 20 dB Attenuator	SN: 5086 (20g)	07-Aug-07 (METAS, No. 217-00716)	Aug-08
Type-N mismatch combination	SN: 5047.2 / 06327	08-Aug-07 (No. 217-00721)	Aug-08
Reference Probe ES3DV2	SN: 3025	28-Apr-08 (No. ES3-3025_Apr08)	Apr-09
DAE4	SN: 601	14-Mar-08 (No. DAE4-601_Mar08)	Mar-09
Secondary Standards	ID #	Check Date (in house)	Scheduled Check
Power sensor HP 8481A	MY41092317	18-Oct-02 (SPEAG, in house check Oct-07)	In house check: Oct-09
RF generator R&S SMT-06	100005	04-Aug-99 (SPEAG, in house check Oct-07)	In house check: Oct-09
Network Analyzer HP 8753E	US37390585 S4208	18-Oct-01 (SPEAG, in house check Oct-07)	In house check: Oct-08

	Name	Function	Signature
Calibrated by:	Jeton Kastrat	Laboratory Technician	
Approved by:	Katja Pokovic	Technical Manager	

Issued: June 13, 2008

This calibration certificate shall not be reproduced except in full without written approval of the laboratory.

Calibration Laboratory of
Schmid & Partner
Engineering AG
Zeughausstrasse 43, 8004 Zurich, Switzerland



S Schweizerischer Kalibrierdienst
C Service suisse d'étalonnage
S Servizio svizzero di taratura
S Swiss Calibration Service

Accredited by the Swiss Accreditation Service (SAS)
The Swiss Accreditation Service is one of the signatories to the EA
Multilateral Agreement for the recognition of calibration certificates

Accreditation No.: **SCS 108**

Glossary:

TSL	tissue simulating liquid
ConvF	sensitivity in TSL / NORM x,y,z
N/A	not applicable or not measured

Calibration is Performed According to the Following Standards:

- IEEE Std 1528-2003, "IEEE Recommended Practice for Determining the Peak Spatial-Averaged Specific Absorption Rate (SAR) in the Human Head from Wireless Communications Devices: Measurement Techniques", December 2003
- IEC 62209-1, "Procedure to measure the Specific Absorption Rate (SAR) for hand-held devices used in close proximity to the ear (frequency range of 300 MHz to 3 GHz)", February 2005
- Federal Communications Commission Office of Engineering & Technology (FCC OET), "Evaluating Compliance with FCC Guidelines for Human Exposure to Radiofrequency Electromagnetic Fields; Additional Information for Evaluating Compliance of Mobile and Portable Devices with FCC Limits for Human Exposure to Radiofrequency Emissions", Supplement C (Edition 01-01) to Bulletin 65

Additional Documentation:

- DASY4/5 System Handbook

Methods Applied and Interpretation of Parameters:

- Measurement Conditions:** Further details are available from the Validation Report at the end of the certificate. All figures stated in the certificate are valid at the frequency indicated.
- Antenna Parameters with TSL:** The dipole is mounted with the spacer to position its feed point exactly below the center marking of the flat phantom section, with the arms oriented parallel to the body axis.
- Feed Point Impedance and Return Loss:** These parameters are measured with the dipole positioned under the liquid filled phantom. The impedance stated is transformed from the measurement at the SMA connector to the feed point. The Return Loss ensures low reflected power. No uncertainty required.
- Electrical Delay:** One-way delay between the SMA connector and the antenna feed point. No uncertainty required.
- SAR measured:** SAR measured at the stated antenna input power.
- SAR normalized:** SAR as measured, normalized to an input power of 1 W at the antenna connector.
- SAR for nominal TSL parameters:** The measured TSL parameters are used to calculate the nominal SAR result..

Measurement Conditions

DASY system configuration, as far as not given on page 1.

DASY Version	DASY4	V4.7
Extrapolation	Advanced Extrapolation	
Phantom	Modular Flat Phantom V4.9	
Distance Dipole Center - TSL	15 mm	with Spacer
Zoom Scan Resolution	dx, dy, dz = 5 mm	
Frequency	835 MHz ± 1 MHz	

Head TSL parameters

The following parameters and calculations were applied.

	Temperature	Permittivity	Conductivity
Nominal Head TSL parameters	22.0 °C	41.5	0.90 mho/m
Measured Head TSL parameters	(22.0 ± 0.2) °C	40.4 ± 6 %	0.88 mho/m ± 6 %
Head TSL temperature during test	(21.6 ± 0.2) °C	---	---

SAR result with Head TSL

SAR averaged over 1 cm ³ (1 g) of Head TSL	Condition	
SAR measured	250 mW input power	2.29 mW / g
SAR normalized	normalized to 1W	9.16 mW / g
SAR for nominal Head TSL parameters ¹	normalized to 1W	9.14 mW / g ± 17.0 % (k=2)

SAR averaged over 10 cm ³ (10 g) of Head TSL	condition	
SAR measured	250 mW input power	1.52 mW / g
SAR normalized	normalized to 1W	6.08 mW / g
SAR for nominal Head TSL parameters ¹	normalized to 1W	6.05 mW / g ± 16.5 % (k=2)

¹ Correction to nominal TSL parameters according to d), chapter "SAR Sensitivities"

Body TSL parameters

The following parameters and calculations were applied.

	Temperature	Permittivity	Conductivity
Nominal Body TSL parameters	22.0 °C	55.2	0.97 mho/m
Measured Body TSL parameters	(22.0 ± 0.2) °C	53.4 ± 6 %	0.99 mho/m ± 6 %
Body TSL temperature during test	(21.5 ± 0.2) °C	---	---

SAR result with Body TSL

SAR averaged over 1 cm ³ (1 g) of Body TSL	Condition	
SAR measured	250 mW input power	2.44 mW / g
SAR normalized	normalized to 1W	9.76 mW / g
SAR for nominal Body TSL parameters ²	normalized to 1W	9.43 mW / g ± 17.0 % (k=2)

SAR averaged over 10 cm ³ (10 g) of Body TSL	condition	
SAR measured	250 mW input power	1.61 mW / g
SAR normalized	normalized to 1W	6.44 mW / g
SAR for nominal Body TSL parameters ²	normalized to 1W	6.28 mW / g ± 16.5 % (k=2)

² Correction to nominal TSL parameters according to d), chapter "SAR Sensitivities"

Appendix

Antenna Parameters with Head TSL

Impedance, transformed to feed point	53.0 Ω - 2.4 j Ω
Return Loss	-28.6 dB

Antenna Parameters with Body TSL

Impedance, transformed to feed point	48.2 Ω - 4.2 j Ω
Return Loss	- 26.7 dB

General Antenna Parameters and Design

Electrical Delay (one direction)	1.391 ns
----------------------------------	----------

After long term use with 100W radiated power, only a slight warming of the dipole near the feedpoint can be measured.

The dipole is made of standard semirigid coaxial cable. The center conductor of the feeding line is directly connected to the second arm of the dipole. The antenna is therefore short-circuited for DC-signals.

No excessive force must be applied to the dipole arms, because they might bend or the soldered connections near the feedpoint may be damaged.

Additional EUT Data

Manufactured by	SPEAG
Manufactured on	November 27, 2006

DASY4 Validation Report for Head TSL

Date/Time: 05.06.2008 14:11:53

Test Laboratory: SPEAG, Zurich, Switzerland

DUT: Dipole 835 MHz; Type: D835V2; Serial: D835V2 - SN:4d063

Communication System: CW-835; Frequency: 835 MHz; Duty Cycle: 1:1
Medium: HSL 900 MHz;
Medium parameters used: $f = 835$ MHz; $\sigma = 0.879$ mho/m; $\epsilon_r = 40.3$; $\rho = 1000$ kg/m³
Phantom section: Flat Section
Measurement Standard: DASY4 (High Precision Assessment)

DASY4 Configuration:

- Probe: ES3DV2 - SN3025; ConvF(5.97, 5.97, 5.97); Calibrated: 28.04.2008
- Sensor-Surface: 3.4mm (Mechanical Surface Detection)
- Electronics: DAE4 Sn601; Calibrated: 14.03.2008
- Phantom: Flat Phantom 4.9L; Type: QD000P49AA; ;
- Measurement SW: DASY4, V4.7 Build 71; Postprocessing SW: SEMCAD, V1.8 Build 184

Pin=250mW; dip=15mm; dist=3.4mm/Zoom Scan (7x7x7)/Cube 0: Measurement grid: dx=5mm, dy=5mm, dz=5mm
Reference Value = 55.3 V/m; Power Drift = -0.021 dB
Peak SAR (extrapolated) = 3.36 W/kg
SAR(1 g) = 2.29 mW/g; SAR(10 g) = 1.52 mW/g
Maximum value of SAR (measured) = 2.58 mW/g

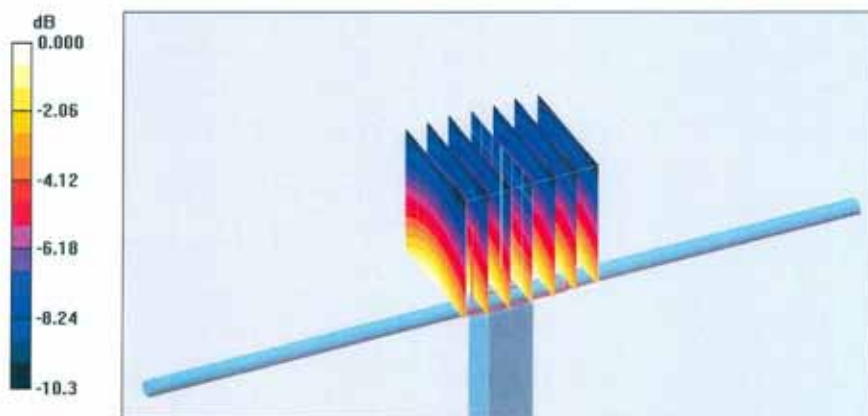

0 dB = 2.58mW/g

Impedance Measurement Plot for Head TSL

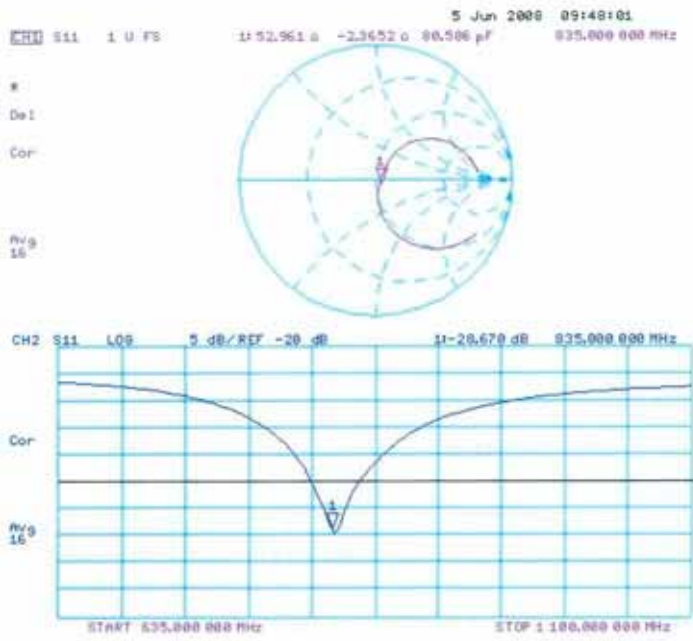

DASY4 Validation Report for Body TSL

Date/Time: 06.06.2008 14:01:1

Test Laboratory: SPEAG, Zurich, Switzerland

DUT: Dipole 835 MHz; Type: D835V2; Serial: D835V2 - SN:4d063

Communication System: CW; Frequency: 835 MHz; Duty Cycle: 1:1

Medium: MSL900;

Medium parameters used: $f = 835$ MHz; $\sigma = 0.99$ mho/m; $\epsilon_r = 53.4$; $\rho = 1000$ kg/m³

Phantom section: Flat Section

Measurement Standard: DASY4 (High Precision Assessment)

DASY4 Configuration:

- Probe: ES3DV2 - SN3025; ConvF(5.9, 5.9, 5.9); Calibrated: 28.04.2008
- Sensor-Surface: 3.4mm (Mechanical Surface Detection)
- Electronics: DAE4 Sn601; Calibrated: 14.03.2008
- Phantom: Flat Phantom 4.9L; Type: QD000P49AA; ;
- Measurement SW: DASY4, V4.7 Build 71; Postprocessing SW: SEMCAD, V1.8 Build 184

Pin = 250mW, d = 15mm/Zoom Scan (7x7x7)/Cube 0: Measurement grid: dx=5mm, dy=5mm, dz=5mm

Reference Value = 53.6 V/m; Power Drift = 0.010 dB

Peak SAR (extrapolated) = 3.53 W/kg

SAR(1 g) = 2.44 mW/g; SAR(10 g) = 1.61 mW/g

Maximum value of SAR (measured) = 2.73 mW/g

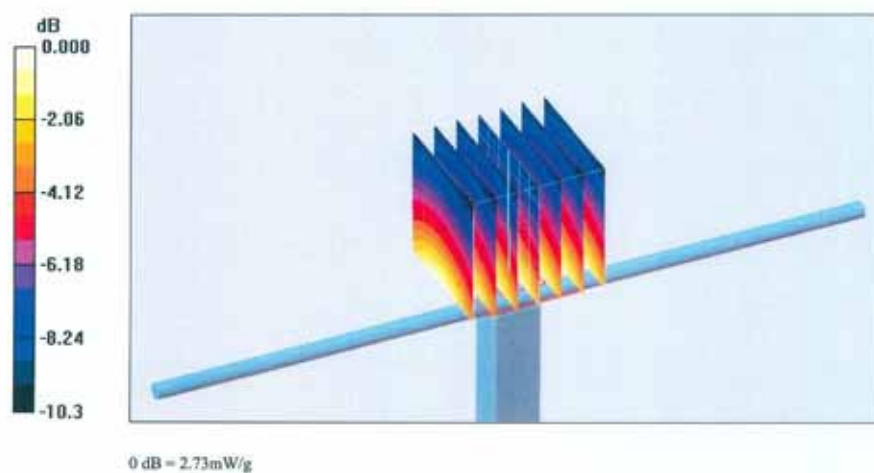

Impedance Measurement Plot for Body TSL

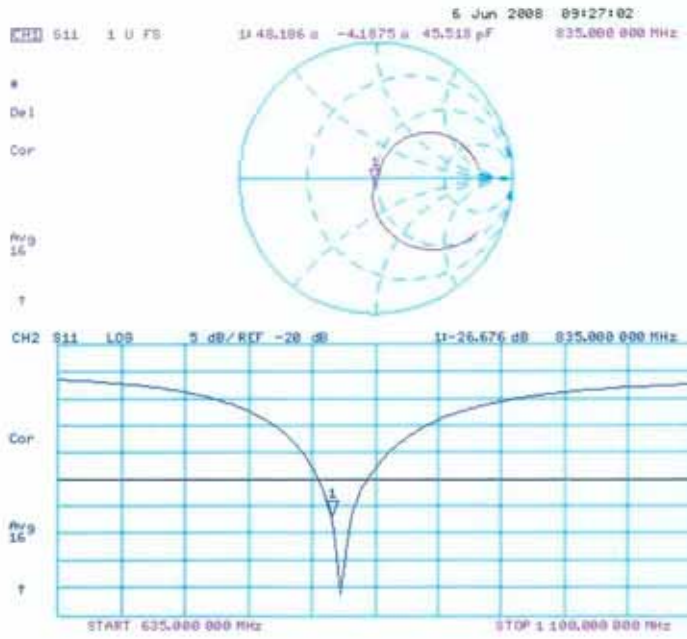

**Calibration Laboratory of
 Schmid & Partner
 Engineering AG**
 Zeughausstrasse 43, 8004 Zurich, Switzerland



S Schweizerischer Kalibrierdienst
C Service suisse d'étalonnage
S Servizio svizzero di taratura
S Swiss Calibration Service

Accredited by the Swiss Federal Office of Metrology and Accreditation
 The Swiss Accreditation Service is one of the signatories to the EA
 Multilateral Agreement for the recognition of calibration certificates

Accreditation No.: **SCS 108**

Client **SGS (Auden)**

Certificate No: **D1900V2-5d027_Apr08**

CALIBRATION CERTIFICATE

Object **D1900V2 - SN: 5d027**

Calibration procedure(s) **QA CAL-05.v7
 Calibration procedure for dipole validation kits**

Calibration date: **April 15, 2008**

Condition of the calibrated item **In Tolerance**

This calibration certificate documents the traceability to national standards, which realize the physical units of measurements (SI).
 The measurements and the uncertainties with confidence probability are given on the following pages and are part of the certificate.

All calibrations have been conducted in the closed laboratory facility: environment temperature (22 ± 3)°C and humidity < 70%.

Calibration Equipment used (M&TE critical for calibration)

Primary Standards	ID #	Cal Date (Calibrated by, Certificate No.)	Scheduled Calibration
Power meter EPM-442A	GB37480704	04-Oct-07 (No. 217-00736)	Oct-08
Power sensor HP 8481A	US37292783	04-Oct-07 (No. 217-00736)	Oct-08
Reference 20 dB Attenuator	SN: 5086 (20g)	07-Aug-07 (No. 217-00718)	Aug-08
Type-N mismatch combination	SN: 5047.2 / 06327	08-Aug-07 (No. 217-00721)	Aug-08
Reference Probe ES3DV2	SN: 3025	01-Mar-08 (No. ES3-3025_Mar08)	Mar-09
DAE4	SN: 601	14-Mar-08 (No. DAE4-601_Mar08)	Mar-09
Secondary Standards	ID #	Check Date (in house)	Scheduled Check
Power sensor HP 8481A	MY41092317	18-Oct-02 (in house check Oct-07)	In house check: Oct-08
RF generator R&S SMT-06	100005	4-Aug-99 (in house check Oct-07)	In house check: Oct-09
Network Analyzer HP 8753E	US37390585 S4206	18-Oct-01 (in house check Oct-07)	In house check: Oct-08

	Name	Function	Signature
Calibrated by:	Marcel Fehr	Laboratory Technician	
Approved by:	Katja Pokovic	Technical Manager	

Issued: April 17, 2008

This calibration certificate shall not be reproduced except in full without written approval of the laboratory.

Calibration Laboratory of
Schmid & Partner
Engineering AG
Zeughausstrasse 43, 8004 Zurich, Switzerland



S Schweizerischer Kalibrierdienst
C Service suisse d'étalonnage
S Servizio svizzero di taratura
S Swiss Calibration Service

Accredited by the Swiss Accreditation Service (SAS)
The Swiss Accreditation Service is one of the signatories to the EA
Multilateral Agreement for the recognition of calibration certificates

Accreditation No.: **SCS 108**

Glossary:

TSL	tissue simulating liquid
ConvF	sensitivity in TSL / NORM x,y,z
N/A	not applicable or not measured

Calibration is Performed According to the Following Standards:

- a) IEEE Std 1528-2003, "IEEE Recommended Practice for Determining the Peak Spatial-Averaged Specific Absorption Rate (SAR) in the Human Head from Wireless Communications Devices: Measurement Techniques", December 2003
- b) CENELEC EN 50361, "Basic standard for the measurement of Specific Absorption Rate related to human exposure to electromagnetic fields from mobile phones (300 MHz - 3 GHz), July 2001
- c) Federal Communications Commission Office of Engineering & Technology (FCC OET), "Evaluating Compliance with FCC Guidelines for Human Exposure to Radiofrequency Electromagnetic Fields; Additional Information for Evaluating Compliance of Mobile and Portable Devices with FCC Limits for Human Exposure to Radiofrequency Emissions", Supplement C (Edition 01-01) to Bulletin 65

Additional Documentation:

- d) DASY4 System Handbook

Methods Applied and Interpretation of Parameters:

- *Measurement Conditions:* Further details are available from the Validation Report at the end of the certificate. All figures stated in the certificate are valid at the frequency indicated.
- *Antenna Parameters with TSL:* The dipole is mounted with the spacer to position its feed point exactly below the center marking of the flat phantom section, with the arms oriented parallel to the body axis.
- *Feed Point Impedance and Return Loss:* These parameters are measured with the dipole positioned under the liquid filled phantom. The impedance stated is transformed from the measurement at the SMA connector to the feed point. The Return Loss ensures low reflected power. No uncertainty required.
- *Electrical Delay:* One-way delay between the SMA connector and the antenna feed point. No uncertainty required.
- *SAR measured:* SAR measured at the stated antenna input power.
- *SAR normalized:* SAR as measured, normalized to an input power of 1 W at the antenna connector.
- *SAR for nominal TSL parameters:* The measured TSL parameters are used to calculate the nominal SAR result.

Measurement Conditions

DASY system configuration, as far as not given on page 1.

DASY Version	DASY4	V4.7
Extrapolation	Advanced Extrapolation	
Phantom	Modular Flat Phantom V5.0	
Distance Dipole Center - TSL	10 mm	with Spacer
Zoom Scan Resolution	dx, dy, dz = 5 mm	
Frequency	1900 MHz \pm 1 MHz	

Head TSL parameters

The following parameters and calculations were applied.

	Temperature	Permittivity	Conductivity
Nominal Head TSL parameters	22.0 °C	40.0	1.40 mho/m
Measured Head TSL parameters	(22.0 \pm 0.2) °C	40.1 \pm 6 %	1.47 mho/m \pm 6 %
Head TSL temperature during test	(21.5 \pm 0.2) °C	—	—

SAR result with Head TSL

SAR averaged over 1 cm ³ (1 g) of Head TSL	condition	
SAR measured	250 mW input power	10.3 mW / g
SAR normalized	normalized to 1W	41.2 mW / g
SAR for nominal Head TSL parameters ¹	normalized to 1W	40.2 mW / g \pm 17.0 % (k=2)

SAR averaged over 10 cm ³ (10 g) of Head TSL	Condition	
SAR measured	250 mW input power	5.30 mW / g
SAR normalized	normalized to 1W	21.2 mW / g
SAR for nominal Head TSL parameters ¹	normalized to 1W	21.0 mW / g \pm 16.5 % (k=2)

¹ Correction to nominal TSL parameters according to d), chapter "SAR Sensitivities"

Body TSL parameters

The following parameters and calculations were applied.

	Temperature	Permittivity	Conductivity
Nominal Body TSL parameters	22.0 °C	53.3	1.52 mho/m
Measured Body TSL parameters	(22.0 ± 0.2) °C	51.4 ± 6 %	1.56 mho/m ± 6 %
Body TSL temperature during test	(20.7 ± 0.2) °C	---	---

SAR result with Body TSL

SAR averaged over 1 cm ³ (1 g) of Body TSL	Condition	
SAR measured	250 mW input power	9.64 mW / g
SAR normalized	normalized to 1W	38.6 mW / g
SAR for nominal Body TSL parameters ²	normalized to 1W	37.2 mW / g ± 17.0 % (k=2)

SAR averaged over 10 cm ³ (10 g) of Body TSL	condition	
SAR measured	250 mW input power	5.07 mW / g
SAR normalized	normalized to 1W	20.3 mW / g
SAR for nominal Body TSL parameters ²	normalized to 1W	19.8 mW / g ± 16.5 % (k=2)

² Correction to nominal TSL parameters according to d), chapter "SAR Sensitivities".

Appendix

Antenna Parameters with Head TSL

Impedance, transformed to feed point	$51.9 \Omega + 6.2 j\Omega$
Return Loss	- 24.0 dB

Antenna Parameters with Body TSL

Impedance, transformed to feed point	$48.6 \Omega + 6.3 j\Omega$
Return Loss	- 23.6 dB

General Antenna Parameters and Design

Electrical Delay (one direction)	1.197 ns
----------------------------------	----------

After long term use with 100W radiated power, only a slight warming of the dipole near the feedpoint can be measured.

The dipole is made of standard semirigid coaxial cable. The center conductor of the feeding line is directly connected to the second arm of the dipole. The antenna is therefore short-circuited for DC-signals.

No excessive force must be applied to the dipole arms, because they might bend or the soldered connections near the feedpoint may be damaged.

Additional EUT Data

Manufactured by	SPEAG
Manufactured on	December 17, 2002

DASY4 Validation Report for Head TSL

Date/Time: 08.04.2008 13:49:58

Test Laboratory: SPEAG, Zurich, Switzerland

DUT: Dipole 1900 MHz; Type: D1900V2; Serial: D1900V2 - SN:5d027

Communication System: CW; Frequency: 1900 MHz; Duty Cycle: 1:1

Medium: HSL U10 BB;

Medium parameters used: $f = 1900$ MHz; $\sigma = 1.47$ mho/m; $\epsilon_r = 40.1$; $\rho = 1000$ kg/m³

Phantom section: Flat Section

Measurement Standard: DASY4 (High Precision Assessment)

DASY4 Configuration:

- Probe: ES3DV2 - SN3025; ConvF(4.9, 4.9, 4.9); Calibrated: 01.03.2008
- Sensor-Surface: 3.4mm (Mechanical Surface Detection)
- Electronics: DAE4 Sn601; Calibrated: 14.03.2008
- Phantom: Flat Phantom 5.0 (front); Type: QD000P50AA; ;
- Measurement SW: DASY4, V4.7 Build 55; Postprocessing SW: SEMCAD, V1.8 Build 172

Pin = 250 mW; d = 10 mm/Zoom Scan (7x7x7)/Cube 0:

Measurement grid: dx=5mm, dy=5mm, dz=5mm

Reference Value = 92.2 V/m; Power Drift = 0.033 dB

Peak SAR (extrapolated) = 19.1 W/kg

SAR(1 g) = 10.3 mW/g; SAR(10 g) = 5.3 mW/g

Maximum value of SAR (measured) = 11.9 mW/g

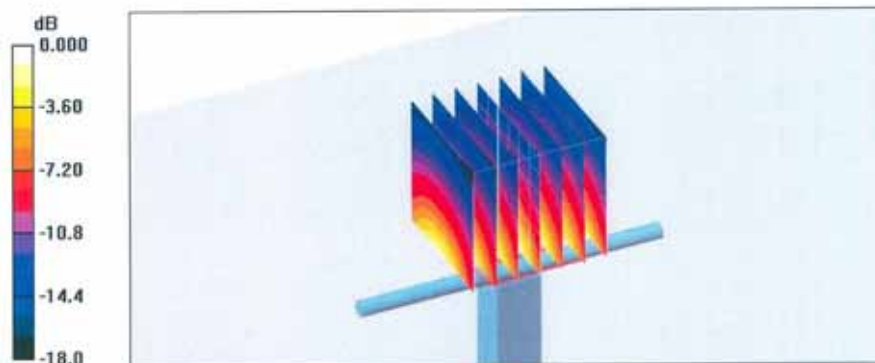

0 dB = 11.9mW/g

Impedance Measurement Plot for Head TSL

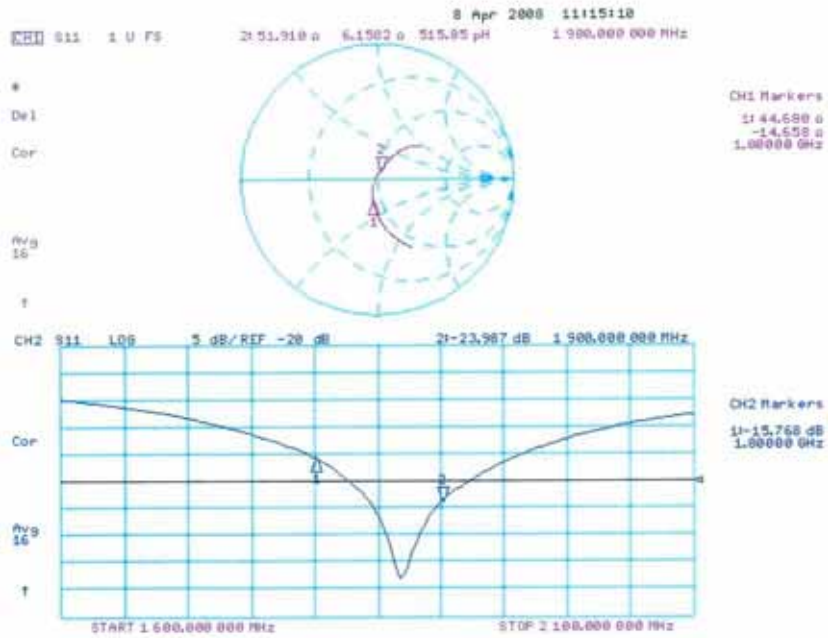

DASY4 Validation Report for Body TSL

Date/Time: 15.04.2008 13:51:25

Test Laboratory: SPEAG, Zurich, Switzerland

DUT: Dipole 1900 MHz; Type: D1900V2; Serial: D1900V2 - SN:5d027

Communication System: CW; Frequency: 1900 MHz; Duty Cycle: 1:1

Medium: MSL U10 BB;

Medium parameters used: $f = 1900$ MHz; $\sigma = 1.56$ mho/m; $\epsilon_r = 51.6$; $\rho = 1000$ kg/m³

Phantom section: Flat Section

Measurement Standard: DASY4 (High Precision Assessment)

DASY4 Configuration:

- Probe: ES3DV2 - SN3025; ConvF(4.5, 4.5, 4.5); Calibrated: 01.03.2008
- Sensor-Surface: 3.4mm (Mechanical Surface Detection)
- Electronics: DAE4 Sn601; Calibrated: 14.03.2008
- Phantom: Flat Phantom 5.0 (back); Type: QD000P50AA; ;
- Measurement SW: DASY4, V4.7 Build 55; Postprocessing SW: SEMCAD, V1.8 Build 172

Pin = 250 mW; d = 10 mm/Zoom Scan (7x7x7)/Cube 0:

Measurement grid: dx=5mm, dy=5mm, dz=5mm

Reference Value = 89.3 V/m; Power Drift = -0.022 dB

Peak SAR (extrapolated) = 17.4 W/kg

SAR(1 g) = 9.64 mW/g; SAR(10 g) = 5.07 mW/g

Maximum value of SAR (measured) = 11.7 mW/g

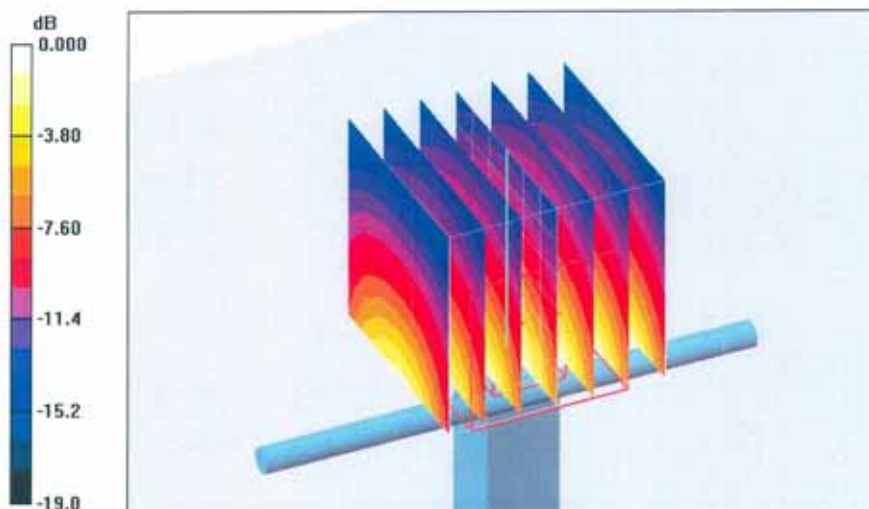

Impedance Measurement Plot for Body TSL

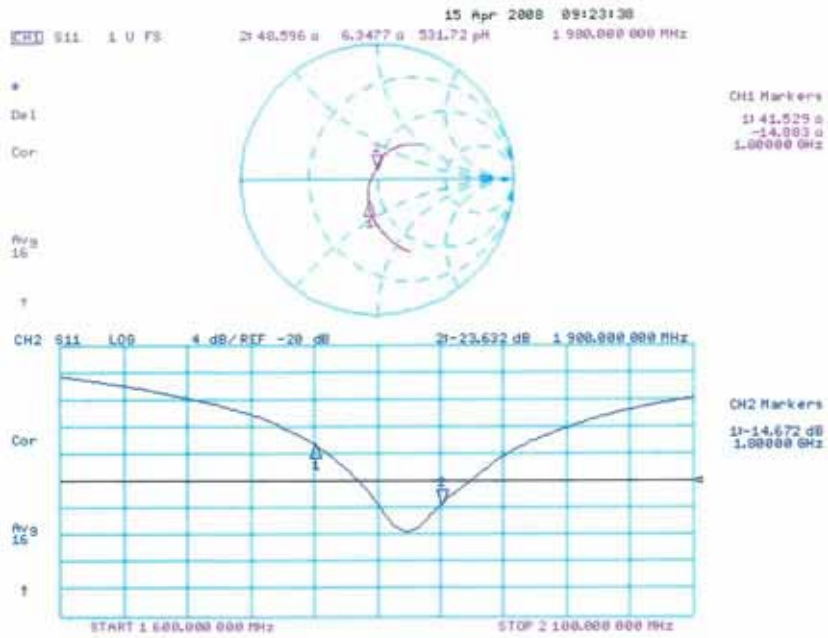

**Calibration Laboratory of
Schmid & Partner
Engineering AG**
Zeughausstrasse 43, 8004 Zurich, Switzerland



S Schweizerischer Kalibrierdienst
C Service suisse d'étalonnage
S Servizio svizzero di taratura
S Swiss Calibration Service

Accredited by the Swiss Accreditation Service (SAS)
The Swiss Accreditation Service is one of the signatories to the EA
Multilateral Agreement for the recognition of calibration certificates

Accreditation No.: **SCS 108**

Client **SGS (Auden)**

Certificate No: **D2450V2-727_Apr08**

CALIBRATION CERTIFICATE

Object **D2450V2 - SN: 727**

Calibration procedure(s) **QA CAL-05.v7
Calibration procedure for dipole validation kits**

Calibration date: **April 11, 2008**

Condition of the calibrated item **In Tolerance**

This calibration certificate documents the traceability to national standards, which realize the physical units of measurements (SI).
The measurements and the uncertainties with confidence probability are given on the following pages and are part of the certificate.

All calibrations have been conducted in the closed laboratory facility: environment temperature (22 ± 3)°C and humidity < 70%.

Calibration Equipment used (M&TE critical for calibration)

Primary Standards	ID #	Cal Date (Certificate No.)	Scheduled Calibration
Power meter EPM-442A	GB37480704	04-Oct-07 (No. 217-00736)	Oct-08
Power sensor HP B481A	US37292783	04-Oct-07 (No. 217-00736)	Oct-08
Reference 20 dB Attenuator	SN: 5086 (20g)	07-Aug-07 (No. 217-00718)	Aug-08
Reference Probe ES3DV2	SN: 3025	01-Mar-08 (No. ES3-3025_Mar08)	Mar-09
DAE4	SN: 601	14-Mar-08 (No. DAE4-601_Mar08)	Mar-09

Secondary Standards	ID #	Check Date (in house)	Scheduled Check
Power sensor HP B481A	MY41092317	18-Oct-02 (in house check Oct-07)	In house check: Oct-09
RF generator R&S SMT-06	100005	4-Aug-99 (in house check Oct-07)	In house check: Oct-09
Network Analyzer HP 8753E	US37390585 S4206	18-Oct-01 (in house check Oct-07)	In house check: Oct-08

Calibrated by: **Name: Mike Meili, Function: Laboratory Technician, Signature: [Signature]**

Approved by: **Name: Katja Pokovic, Function: Technical Manager, Signature: [Signature]**

Issued: April 14, 2008

This calibration certificate shall not be reproduced except in full without written approval of the laboratory.

Calibration Laboratory of
Schmid & Partner
Engineering AG
Zeughausstrasse 43, 8004 Zurich, Switzerland



S Schweizerischer Kalibrierdienst
C Service suisse d'étalonnage
S Servizio svizzero di taratura
S Swiss Calibration Service

Accredited by the Swiss Accreditation Service (SAS)
The Swiss Accreditation Service is one of the signatories to the EA
Multilateral Agreement for the recognition of calibration certificates

Accreditation No.: SCS 108

Glossary:

TSL tissue simulating liquid
ConvF sensitivity in TSL / NORM x,y,z
N/A not applicable or not measured

Calibration is Performed According to the Following Standards:

- a) IEEE Std 1528-2003, "IEEE Recommended Practice for Determining the Peak Spatial-Averaged Specific Absorption Rate (SAR) in the Human Head from Wireless Communications Devices: Measurement Techniques", December 2003
- b) IEC 62209-1, "Procedure to measure the Specific Absorption Rate (SAR) for hand-held devices used in close proximity to the ear (frequency range of 300 MHz to 3 GHz)", February 2005
- c) Federal Communications Commission Office of Engineering & Technology (FCC OET), "Evaluating Compliance with FCC Guidelines for Human Exposure to Radiofrequency Electromagnetic Fields; Additional Information for Evaluating Compliance of Mobile and Portable Devices with FCC Limits for Human Exposure to Radiofrequency Emissions", Supplement C (Edition 01-01) to Bulletin 65

Additional Documentation:

- d) DASY4/5 System Handbook

Methods Applied and Interpretation of Parameters:

- *Measurement Conditions:* Further details are available from the Validation Report at the end of the certificate. All figures stated in the certificate are valid at the frequency indicated.
- *Antenna Parameters with TSL:* The dipole is mounted with the spacer to position its feed point exactly below the center marking of the flat phantom section, with the arms oriented parallel to the body axis.
- *Feed Point Impedance and Return Loss:* These parameters are measured with the dipole positioned under the liquid filled phantom. The impedance stated is transformed from the measurement at the SMA connector to the feed point. The Return Loss ensures low reflected power. No uncertainty required.
- *Electrical Delay:* One-way delay between the SMA connector and the antenna feed point. No uncertainty required.
- *SAR measured:* SAR measured at the stated antenna input power.
- *SAR normalized:* SAR as measured, normalized to an input power of 1 W at the antenna connector.

SAR for nominal TSL parameters: The measured TSL parameters are used to calculate the nominal SAR result.

Measurement Conditions

DASY system configuration, as far as not given on page 1.

DASY Version	DASY4	V4.7
Extrapolation	Advanced Extrapolation	
Phantom	Modular Flat Phantom V5.0	
Distance Dipole Center - TSL	10 mm	with Spacer
Zoom Scan Resolution	$\Delta x, \Delta y, \Delta z = 5 \text{ mm}$	
Frequency	2450 MHz \pm 1 MHz	

Head TSL parameters

The following parameters and calculations were applied.

	Temperature	Permittivity	Conductivity
Nominal Head TSL parameters	22.0 °C	39.2	1.80 mho/m
Measured Head TSL parameters	(22.0 \pm 0.2) °C	39.4 \pm 6 %	1.84 mho/m \pm 6 %
Head TSL temperature during test	(21.6 \pm 0.2) °C	-----	-----

SAR result with Head TSL

SAR averaged over 1 cm³ (1 g) of Head TSL		
	condition	
SAR measured	250 mW input power	13.9 mW / g
SAR normalized	normalized to 1W	55.6 mW / g
SAR for nominal Head TSL parameters ¹	normalized to 1W	55.2 mW / g \pm 17.0 % (k=2)
SAR averaged over 10 cm³ (10 g) of Head TSL		
	condition	
SAR measured	250 mW input power	6.44 mW / g
SAR normalized	normalized to 1W	25.8 mW / g
SAR for nominal Head TSL parameters ¹	normalized to 1W	25.7 mW / g \pm 16.5 % (k=2)

¹ Correction to nominal TSL parameters according to d), chapter "SAR Sensitivities"

Body TSL parameters

The following parameters and calculations were applied.

	Temperature	Permittivity	Conductivity
Nominal Body TSL parameters	22.0 °C	52.7	1.95 mho/m
Measured Body TSL parameters	(22.0 ± 0.2) °C	50.9 ± 6 %	1.98 mho/m ± 6 %
Body TSL temperature during test	(21.2 ± 0.2) °C	-----	-----

SAR result with Body TSL

SAR averaged over 1 cm ³ (1 g) of Body TSL	condition	
SAR measured	250 mW input power	13.2 mW / g
SAR normalized	normalized to 1W	52.8 mW / g
SAR for nominal Body TSL parameters ²	normalized to 1W	51.4 mW / g ± 17.0 % (k=2)

SAR averaged over 10 cm ³ (10 g) of Body TSL	condition	
SAR measured	250 mW input power	6.15 mW / g
SAR normalized	normalized to 1W	24.6 mW / g
SAR for nominal Body TSL parameters ²	normalized to 1W	24.2 mW / g ± 16.5 % (k=2)

² Correction to nominal TSL parameters according to d), chapter "SAR Sensitivities"

Appendix

Antenna Parameters with Head TSL

Impedance, transformed to feed point	53.2 Ω + 3.3 j Ω
Return Loss	- 27.0 dB

Antenna Parameters with Body TSL

Impedance, transformed to feed point	50.6 Ω + 7.5 j Ω
Return Loss	- 22.5 dB

General Antenna Parameters and Design

Electrical Delay (one direction)	1.149 ns
----------------------------------	----------

After long term use with 100W radiated power, only a slight warming of the dipole near the feedpoint can be measured.

The dipole is made of standard semirigid coaxial cable. The center conductor of the feeding line is directly connected to the second arm of the dipole. The antenna is therefore short-circuited for DC-signals.

No excessive force must be applied to the dipole arms, because they might bend or the soldered connections near the feedpoint may be damaged.

Additional EUT Data

Manufactured by	SPEAG
Manufactured on	January 9, 2003

DASY4 Validation Report for Head TSL

Date/Time: 11.04.2008 13:11:14

Test Laboratory: SPEAG, Zurich, Switzerland

DUT: Dipole 2450 MHz; Type: D2450V2; Serial: D2450V2 - SN727

Communication System: CW-2450; Frequency: 2450 MHz; Duty Cycle: 1:1

Medium: HSL U10 BB;

Medium parameters used: $f = 2450$ MHz; $\sigma = 1.84$ mho/m; $\epsilon_r = 39.4$; $\rho = 1000$ kg/m³

Phantom section: Flat Section

Measurement Standard: DASY4 (High Precision Assessment)

DASY4 Configuration:

- Probe: ES3DV2 - SN3025; ConvF(4.4, 4.4, 4.4); Calibrated: 01.03.2008
- Sensor-Surface: 3.4mm (Mechanical Surface Detection)
- Electronics: DAE4 Ssf01; Calibrated: 14.03.2008
- Phantom: Flat Phantom 5.0 (front); Type: QD000P50AA
- Measurement SW: DASY4, V4.7 Build 55; Postprocessing SW: SEMCAD, V1.8 Build 172

Pin = 250 mW; d = 10 mm/Zoom Scan (7x7x7)/Cube 0:

Measurement grid: dx=5mm, dy=5mm, dz=5mm

Reference Value = 99.0 V/m; Power Drift = 0.015 dB

Peak SAR (extrapolated) = 28.6 W/kg

SAR(1 g) = 13.9 mW/g; SAR(10 g) = 6.44 mW/g

Maximum value of SAR (measured) = 17.2 mW/g

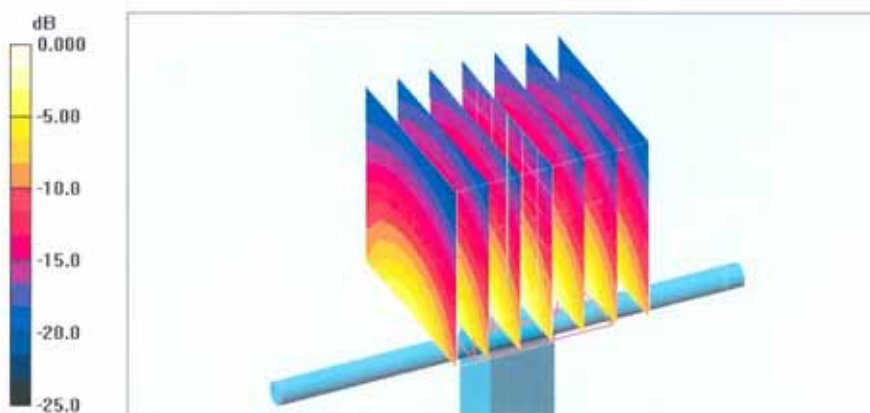

0 dB = 17.2mW/g

Impedance Measurement Plot for Head TSL

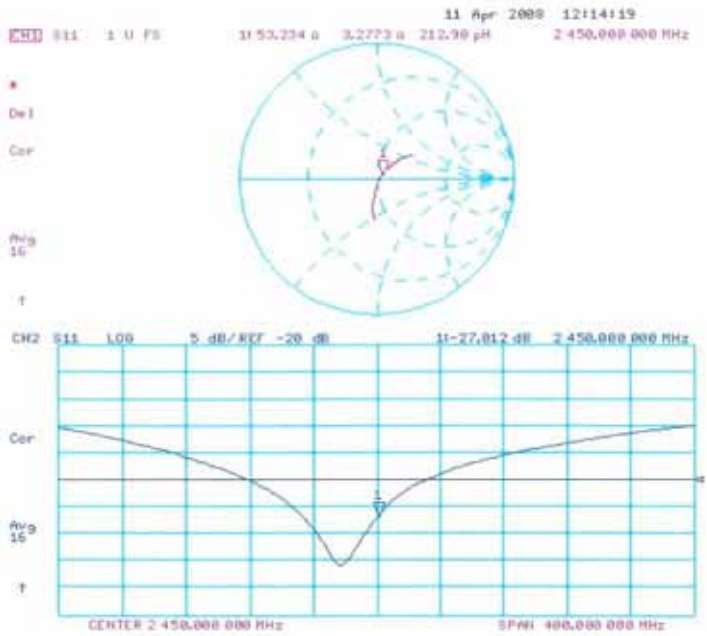

DASY4 Validation Report for Body TSL

Date/Time: 11.04.2008 15:23:03

Test Laboratory: SPEAG, Zurich, Switzerland

DUT: Dipole 2450 MHz; Type: D2450V2; Serial: D2450V2 - SN727

Communication System: CW-2450; Frequency: 2450 MHz; Duty Cycle: 1:1

Medium: MSL U10;

Medium parameters used: $f = 2450$ MHz; $\sigma = 1.99$ mho/m; $\epsilon_r = 51$; $\rho = 1000$ kg/m³

Phantom section: Flat Section

Measurement Standard: DASY4 (High Precision Assessment)

DASY4 Configuration:

- Probe: ES3DV2 - SN3025; ConvF(4.07, 4.07, 4.07); Calibrated: 01.03.2008
- Sensor-Surface: 3.4mm (Mechanical Surface Detection)
- Electronics: DAE4 Sn601; Calibrated: 14.03.2008
- Phantom: Flat Phantom 5.0 (back); Type: QD000P50AA
- Measurement SW: DASY4, V4.7 Build 55; Postprocessing SW: SEMCAD, V1.8 Build 172

Pin = 250 mW; d = 10 mm/Zoom Scan (7x7x7)/Cube 0:

Measurement grid: dx=5mm, dy=5mm, dz=5mm

Reference Value = 93.5 V/m; Power Drift = 0.010 dB

Peak SAR (extrapolated) = 26.5 W/kg

SAR(1 g) = 13.2 mW/g; SAR(10 g) = 6.15 mW/g

Maximum value of SAR (measured) = 16.5 mW/g

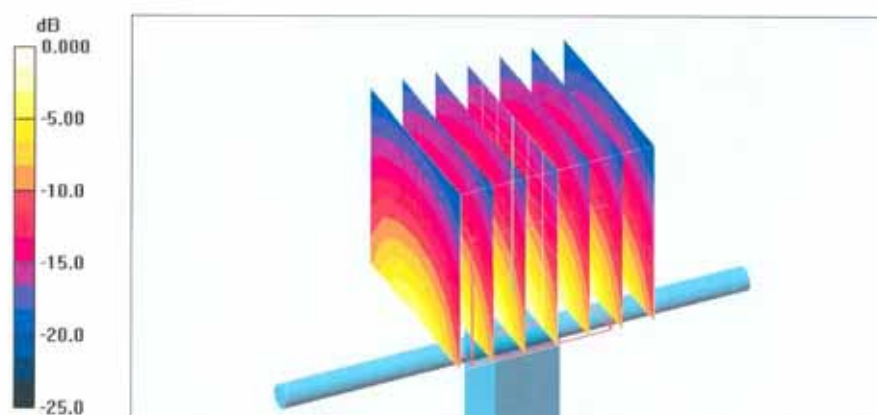

Impedance Measurement Plot for Body TSL

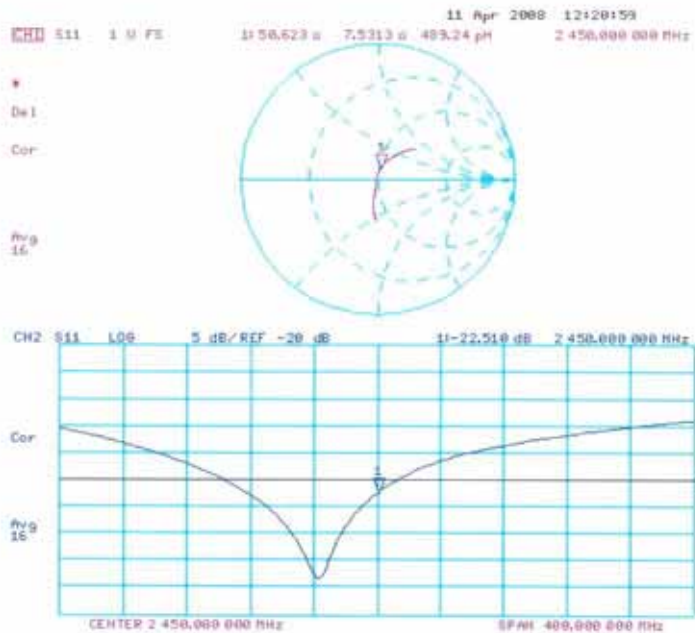

End of 1st part of report