

Processing Gain

Description and test results

MEMORANDUM – PROCESSING GAIN REPORT FOR INTEL(R) PERSONAL WIRELESS MODULE

Subject: Results of Processing Gain Tests for FCC Qualification

1 INTRODUCTION

This memo presents the results of the Processing Gain (PG) tests carried out for FCC qualification of the Intel(R) Personal Wireless Module chip. The FCC states that the PG from a hybrid Bluetooth receiver must be greater than 17 dB when measured in accordance with the Continuous Wave (CW) jamming margin method. Testing of the Intel(R) Personal Wireless Module “B” Bluetooth chip has found the PG due to the DS section to be approximately 5 dB and the PG due to the FH part to be approximately 15 dB. It is therefore concluded that the Intel(R) Personal Wireless Module Bluetooth Chip complies with the FCC PG requirements for radio communication systems.

The rest of this paper outlines the PG measurement technique and discusses the test results. Appendix A contains a list of test equipment and Appendix B contains a printout of the measurement results.

2 METHOD

2.1 PG Definition

The Processing Gain from a frequency hopping communication system is derived from two parts, the FH section and the DS section. The PG due to FH is given by a simple equation and is constant. However measurement of the PG due to DS is a little more complex. One technique is to use the CW jamming margin method. This method measures PG due to DS using the following algorithm:

A CW signal generator is stepped in 50kHz increments across the passband of the system, recording at each point the generator level required to produce the 0.1% Packet Error Rate (PER). This is the jammer level. This level is then referenced to the output power of the intended Bluetooth signal and the Jammer to Signal Ratio JSR is thus calculated. The worst 4 JSR measurements are discarded and the worst remaining JSR is used to calculate the PG due to DS as follows:

$$G_p = SNR + JSR_{\min} + L_{sys}$$

where G_p = the processing gain of the system, SNR = the signal to noise ratio required for 0.1% BER, JSR_{min} = minimum J/S ratio and L_{sys} = system losses.

2.2 PG Measurement Technique

Figure 1 provides an overview of the PG measurement technique. The measurement is performed in two parts, measurement of the system SNR and measurement of JSR_{min} .

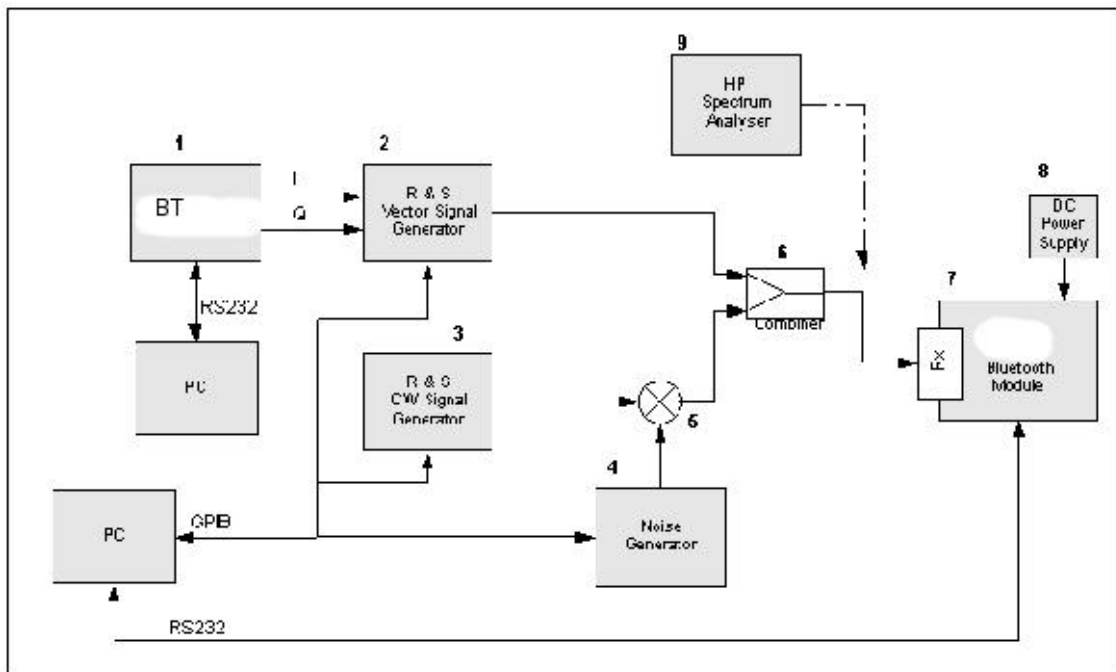

Figure 1: PG Measurement Technique

The system SNR is calculated using the following algorithm. Generate Bluetooth PRBS-9 packets using a Bluetooth chip emulator (1) and a Vector Signal Generator (2). Combine this signal with white noise of a constant level, which is generated using a noise source (4) and a CW Signal Generator (3). Then vary the level of the Bluetooth signal until the BER measured by the Bluetooth chip (7) is 0.1%. The resulting SNR is the signal level divided by the Noise level.

The JSR for a given jamming frequency is calculated using the following algorithm. Generate Bluetooth PRBS-9 packets using the Bluetooth chip emulator (1) and the Vector Signal Generator (2). Combine this signal with a constant CW tone at the jamming frequency using a CW Signal Generator (5) and a combiner (6). Then vary the level of the Bluetooth signal until the PER measured by the Casira Bluetooth Module (7) is 0.1%. The resulting JSR is the signal level divided by the jamming level.

3 RESULTS

3.1 Overview

The measurements found that the PG due to DS caused by the access code in page and inquiry mode is found to be approximately 5dB when the access code is a relatively random mixture of 1's and 0's. A random access code causes the most Inter Symbol Interference (ISI) and hence the worst PG for a hybrid system. Therefore only the results for this access code are used in the PG calculation.

The PG due to FH is given as

$$PG_{FH} = 10 \log_{10}(\text{number of frequency hops})$$

The number of hops in a Bluetooth system is 32, therefore the PG due to FH is approximately 15 dB. When this is added to the PG due to DS, the total PG for the Bluetooth chip is approximately 20 dB, above the minimum PG requirement for FCC qualification.

3.2 Detailed Results

Test Date:	17/11/00
Sample Time:	30 seconds
Access Code:	c6967e
Signal Frequency:	2.432GHz
Receiver Sensitivity:	-88.7 dBm
Jammer Signal Level:	-85.7 dBm
Measured SNR:	18.8dB
System Losses:	2dB

To calculate processing gain, ignore the worst 20% of data points and then apply the following formula:

$$G_p = SNR + JSR_{\min} + L_{\text{sys}}$$

Where G_p = Processing Gain of the module
 SNR = signal to noise ratio of the module
 JS_{\min} = minimum J/S ratio after the worst 20% of J/S samples have been discarded
 L_{sys} = System losses

A total of 20 samples were taken by stepping the jamming signal frequency offsets in 50kHz increments over the bandwidth of the receiver. The worst 4 samples were found at -500kHz, -450kHz, -400kHz and 500kHz and were discarded. The remaining minimum J/S ratio was found to be -15.4dB at an offset of +350kHz

Thus, the processing gain due to direct sequence spreading in page and inquiry mode is

$$G_p = 18.8 - 15.4 + 2 = 5.4dB$$

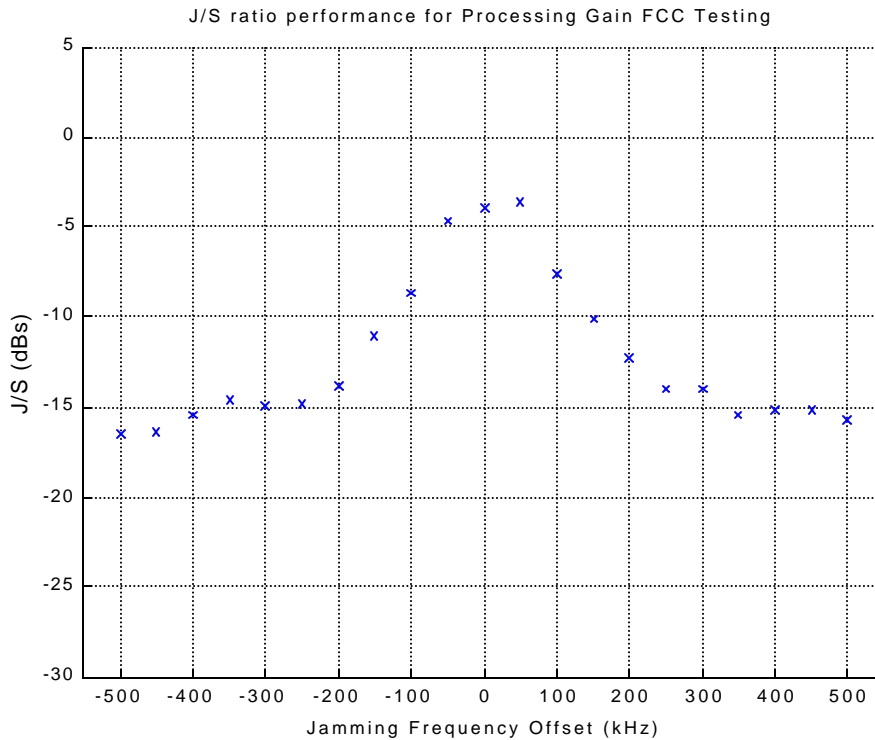

APPENDIX A - TEST EQUIPMENT LIST

Reference:	Instrument Type	Name
1	Bluetooth IC Emulator Board	N/A
2	Vector Signal Generator	IFR2052
3	CW Signal Generator	IFR2025
4	White Noise Generator	HP33120A
5	RF Mixer	M8HC-7
6	RF Combiner	6 dB loss combiner
7	Bluetooth Motherboard and Bluetooth chip Module	Bluetooth Development Kit
8	5V, 4A DC Power Supply	N/A
9	Spectrum Analyser	HP E4405B

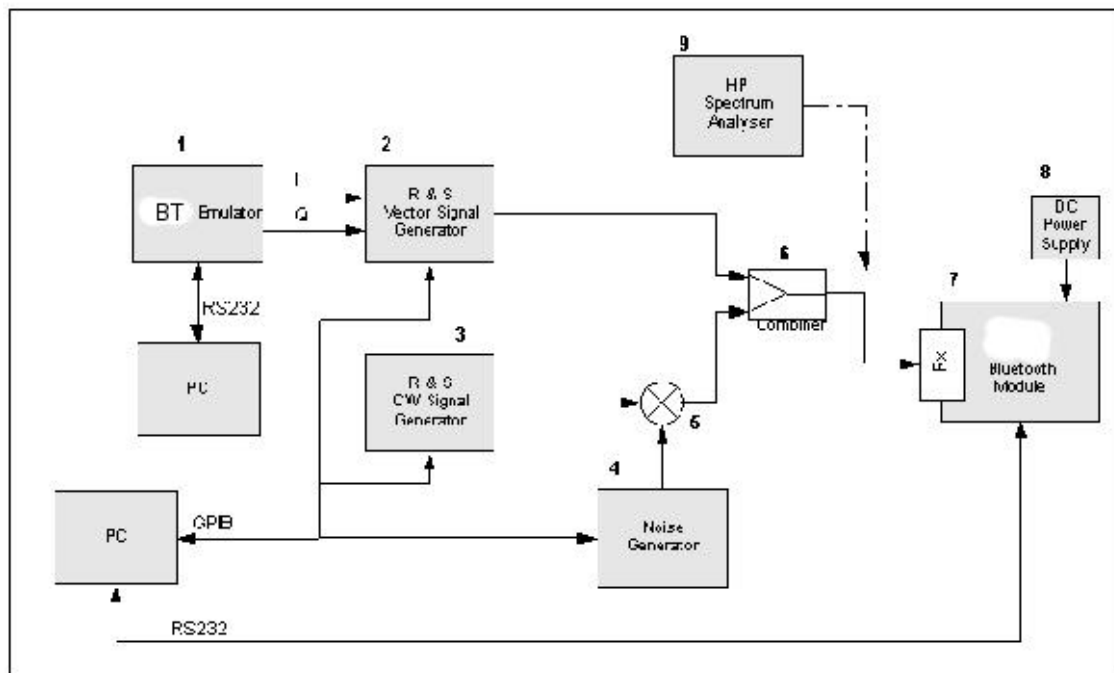

APPENDIX B - TEST RESULTS

Timestamp: 14:42.43, 16/11/2000

Signal Freq = 2.432 GHz

Jammer Level = -85.7 dBm

Jammer Offset = -500 kHz

Level = -68.7 dBm	BER = 0.03%	PER = 0.01%	SER1 = 0.01%	SER2 = 0.01%
Level = -70.7 dBm	BER = 0.32%	PER = 0.79%	SER1 = 0.79%	SER2 = 0.79%
Level = -69.7 dBm	BER = 0.11%	PER = 0.18%	SER1 = 0.18%	SER2 = 0.18%
Level = -68.7 dBm	BER = 0.04%	PER = 0.03%	SER1 = 0.02%	SER2 = 0.02%
Level = -69.2 dBm	BER = 0.06%	PER = 0.05%	SER1 = 0.05%	SER2 = 0.05%
Level = -69.7 dBm	BER = 0.11%	PER = 0.16%	SER1 = 0.16%	SER2 = 0.16%
Level = -69.5 dBm	BER = 0.09%	PER = 0.11%	SER1 = 0.11%	SER2 = 0.11%
Level = -69.3 dBm	BER = 0.07%	PER = 0.05%	SER1 = 0.05%	SER2 = 0.05%

J/S = -16.50 dB (SER = 0.05%)

Signal Freq = 2.432 GHz

Jammer Level = -85.7 dBm

Jammer Offset = -450 kHz

Level = -69.2 dBm	BER = 0.06%	PER = 0.05%	SER1 = 0.05%	SER2 = 0.05%
Level = -71.2 dBm	BER = 0.84%	PER = 1.72%	SER1 = 1.69%	SER2 = 1.69%
Level = -70.2 dBm	BER = 0.26%	PER = 0.40%	SER1 = 0.40%	SER2 = 0.40%
Level = -69.2 dBm	BER = 0.07%	PER = 0.06%	SER1 = 0.06%	SER2 = 0.06%
Level = -69.7 dBm	BER = 0.12%	PER = 0.18%	SER1 = 0.18%	SER2 = 0.18%
Level = -69.5 dBm	BER = 0.09%	PER = 0.14%	SER1 = 0.14%	SER2 = 0.14%
Level = -69.3 dBm	BER = 0.07%	PER = 0.08%	SER1 = 0.08%	SER2 = 0.08%

J/S = -16.40 dB (SER = 0.08%)

Signal Freq = 2.432 GHz

Jammer Level = -85.7 dBm

Jammer Offset = -400 kHz

Level = -69.3 dBm	BER = 0.04%	PER = 0.02%	SER1 = 0.02%	SER2 = 0.02%
Level = -71.3 dBm	BER = 0.44%	PER = 0.72%	SER1 = 0.71%	SER2 = 0.71%
Level = -70.3 dBm	BER = 0.13%	PER = 0.11%	SER1 = 0.11%	SER2 = 0.11%
Level = -69.3 dBm	BER = 0.04%	PER = 0.01%	SER1 = 0.01%	SER2 = 0.01%
Level = -69.8 dBm	BER = 0.08%	PER = 0.03%	SER1 = 0.02%	SER2 = 0.02%
Level = -70.3 dBm	BER = 0.13%	PER = 0.10%	SER1 = 0.10%	SER2 = 0.10%

J/S = -15.40 dB (SER = 0.10%)

Signal Freq = 2.432 GHz

Jammer Level = -85.7 dBm

Jammer Offset = -350 kHz

Level = -70.3 dBm	BER = 0.05%	PER = 0.01%	SER1 = 0.01%	SER2 = 0.01%
Level = -72.3 dBm	BER = 0.88%	PER = 1.67%	SER1 = 1.64%	SER2 = 1.64%
Level = -71.3 dBm	BER = 0.19%	PER = 0.10%	SER1 = 0.10%	SER2 = 0.10%
Level = -70.3 dBm	BER = 0.06%	PER = 0.01%	SER1 = 0.01%	SER2 = 0.01%
Level = -70.8 dBm	BER = 0.09%	PER = 0.04%	SER1 = 0.04%	SER2 = 0.04%
Level = -71.3 dBm	BER = 0.17%	PER = 0.12%	SER1 = 0.12%	SER2 = 0.12%

Level = -71.1 dBm BER = 0.13% PER = 0.05% SER1 = 0.05% SER2 = 0.05%

J/S = -14.60 dB (SER = 0.05%)

Signal Freq = 2.432 GHz

Jammer Level = -85.7 dBm

Jammer Offset = -300 kHz

Level = -71.1 dBm BER = 0.03% PER = 0.15% SER1 = 0.15% SER2 = 0.15%

Level = -69.1 dBm BER = 0.00% PER = 0.00% SER1 = 0.00% SER2 = 0.00%

Level = -70.1 dBm BER = 0.01% PER = 0.00% SER1 = 0.00% SER2 = 0.00%

Level = -71.1 dBm BER = 0.03% PER = 0.19% SER1 = 0.19% SER2 = 0.19%

Level = -70.6 dBm BER = 0.02% PER = 0.04% SER1 = 0.04% SER2 = 0.04%

Level = -70.8 dBm BER = 0.02% PER = 0.09% SER1 = 0.09% SER2 = 0.09%

J/S = -14.90 dB (SER = 0.09%)

Signal Freq = 2.432 GHz

Jammer Level = -85.7 dBm

Jammer Offset = -250 kHz

Level = -70.8 dBm BER = 0.00% PER = 0.03% SER1 = 0.02% SER2 = 0.02%

Level = -72.8 dBm BER = 0.05% PER = 2.34% SER1 = 2.29% SER2 = 2.29%

Level = -71.8 dBm BER = 0.01% PER = 0.33% SER1 = 0.33% SER2 = 0.33%

Level = -70.8 dBm BER = 0.00% PER = 0.03% SER1 = 0.03% SER2 = 0.03%

Level = -71.3 dBm BER = 0.01% PER = 0.11% SER1 = 0.11% SER2 = 0.11%

Level = -71.1 dBm BER = 0.00% PER = 0.11% SER1 = 0.11% SER2 = 0.11%

Level = -70.9 dBm BER = 0.00% PER = 0.03% SER1 = 0.03% SER2 = 0.03%

J/S = -14.80 dB (SER = 0.03%)

Signal Freq = 2.432 GHz

Jammer Level = -85.7 dBm

Jammer Offset = -200 kHz

Level = -70.9 dBm BER = 0.00% PER = 0.00% SER1 = 0.00% SER2 = 0.00%

Level = -72.9 dBm BER = 0.00% PER = 0.34% SER1 = 0.34% SER2 = 0.34%

Level = -71.9 dBm BER = 0.00% PER = 0.07% SER1 = 0.07% SER2 = 0.07%

Level = -72.4 dBm BER = 0.00% PER = 0.15% SER1 = 0.15% SER2 = 0.15%

Level = -72.2 dBm BER = 0.00% PER = 0.12% SER1 = 0.12% SER2 = 0.12%

Level = -72.0 dBm BER = 0.00% PER = 0.05% SER1 = 0.05% SER2 = 0.05%

J/S = -13.80 dB (SER = 0.07%)

Signal Freq = 2.432 GHz

Jammer Level = -85.7 dBm

Jammer Offset = -150 kHz

Level = -71.9 dBm BER = 0.00% PER = 0.00% SER1 = 0.00% SER2 = 0.00%

Level = -73.9 dBm BER = 0.00% PER = 0.03% SER1 = 0.02% SER2 = 0.02%

Level = -75.9 dBm BER = 0.01% PER = 0.83% SER1 = 0.82% SER2 = 0.82%

Level = -74.9 dBm BER = 0.00% PER = 0.16% SER1 = 0.16% SER2 = 0.16%

Level = -73.9 dBm BER = 0.00% PER = 0.03% SER1 = 0.02% SER2 = 0.02%

Level = -74.4 dBm BER = 0.00% PER = 0.08% SER1 = 0.07% SER2 = 0.07%

Level = -74.9 dBm BER = 0.00% PER = 0.18% SER1 = 0.18% SER2 = 0.18%

Level = -74.7 dBm BER = 0.00% PER = 0.10% SER1 = 0.10% SER2 = 0.10%

J/S = -11.00 dB (SER = 0.10%)

Signal Freq = 2.432 GHz

Jammer Level = -85.7 dBm

Jammer Offset = -100 kHz

Level = -74.7 dBm BER = 0.00% PER = 0.00% SER1 = 0.00% SER2 = 0.00%

Level = -76.7 dBm BER = 0.00% PER = 0.05% SER1 = 0.05% SER2 = 0.05%

Level = -78.7 dBm BER = 0.01% PER = 2.05% SER1 = 2.01% SER2 = 2.01%

Level = -77.7 dBm BER = 0.00% PER = 0.30% SER1 = 0.30% SER2 = 0.30%

Level = -76.7 dBm BER = 0.00% PER = 0.06% SER1 = 0.06% SER2 = 0.06%

Level = -77.2 dBm BER = 0.00% PER = 0.13% SER1 = 0.12% SER2 = 0.12%

Level = -77.0 dBm BER = 0.00% PER = 0.08% SER1 = 0.07% SER2 = 0.07%

J/S = -8.70 dB (SER = 0.07%)

Signal Freq = 2.432 GHz

Jammer Level = -85.7 dBm

Jammer Offset = -50 kHz

Level = -77.0 dBm BER = 0.00% PER = 0.00% SER1 = 0.00% SER2 = 0.00%

Level = -79.0 dBm BER = 0.00% PER = 0.00% SER1 = 0.00% SER2 = 0.00%

Level = -81.0 dBm BER = 0.01% PER = 0.05% SER1 = 0.05% SER2 = 0.05%

Level = -83.0 dBm BER = 0.16% PER = 0.73% SER1 = 0.72% SER2 = 0.72%

Level = -82.0 dBm BER = 0.03% PER = 0.26% SER1 = 0.26% SER2 = 0.26%

Level = -81.0 dBm BER = 0.01% PER = 0.06% SER1 = 0.06% SER2 = 0.06%

Level = -81.5 dBm BER = 0.02% PER = 0.13% SER1 = 0.13% SER2 = 0.13%

Level = -81.3 dBm BER = 0.02% PER = 0.11% SER1 = 0.11% SER2 = 0.11%

Level = -81.1 dBm BER = 0.04% PER = 0.06% SER1 = 0.06% SER2 = 0.06%

J/S = -4.60 dB (SER = 0.06%)

Signal Freq = 2.432 GHz

Jammer Level = -85.7 dBm

Jammer Offset = +0 kHz

Level = -68.7 dBm BER = 0.00% PER = 0.00% SER1 = 0.00% SER2 = 0.00%

Level = -70.7 dBm BER = 0.00% PER = 0.00% SER1 = 0.00% SER2 = 0.00%

Level = -72.7 dBm BER = 0.00% PER = 0.00% SER1 = 0.00% SER2 = 0.00%

Level = -74.7 dBm BER = 0.00% PER = 0.00% SER1 = 0.00% SER2 = 0.00%

Level = -76.7 dBm BER = 0.00% PER = 0.00% SER1 = 0.00% SER2 = 0.00%

Level = -78.7 dBm BER = 0.00% PER = 0.00% SER1 = 0.00% SER2 = 0.00%

Level = -80.7 dBm BER = 0.01% PER = 0.00% SER1 = 0.00% SER2 = 0.00%

Level = -82.7 dBm BER = 0.04% PER = 0.04% SER1 = 0.03% SER2 = 0.03%

Level = -84.7 dBm BER = 7.51% PER = 48.26% SER1 = 27.11% SER2 = 28.05%

Level = -83.7 dBm BER = 0.31% PER = 1.01% SER1 = 0.86% SER2 = 0.86%

Level = -82.7 dBm BER = 0.05% PER = 0.24% SER1 = 0.18% SER2 = 0.18%

Level = -81.7 dBm BER = 0.01% PER = 0.00% SER1 = 0.00% SER2 = 0.00%

Level = -82.2 dBm BER = 0.02% PER = 0.13% SER1 = 0.10% SER2 = 0.10%

Level = -82.0 dBm BER = 0.02% PER = 2.31% SER1 = 2.24% SER2 = 2.24%

Level = -81.8 dBm BER = 0.02% PER = 0.06% SER1 = 0.05% SER2 = 0.05%

J/S = -3.90 dB (SER = 0.05%)

Signal Freq = 2.432 GHz
Jammer Level = -85.7 dBm
Jammer Offset = +50 kHz

Level = -81.8 dBm	BER = 0.11%	PER = 0.02%	SER1 = 0.02%	SER2 = 0.02%
Level = -83.8 dBm	BER = 0.68%	PER = 2.16%	SER1 = 1.82%	SER2 = 1.82%
Level = -82.8 dBm	BER = 0.28%	PER = 0.35%	SER1 = 0.29%	SER2 = 0.29%
Level = -81.8 dBm	BER = 0.09%	PER = 0.02%	SER1 = 0.02%	SER2 = 0.02%
Level = -82.3 dBm	BER = 0.15%	PER = 0.25%	SER1 = 0.22%	SER2 = 0.22%
Level = -82.1 dBm	BER = 0.12%	PER = 0.09%	SER1 = 0.07%	SER2 = 0.07%

J/S = -3.60 dB (SER = 0.07%)

Signal Freq = 2.432 GHz
Jammer Level = -85.7 dBm
Jammer Offset = +100 kHz

Level = -82.1 dBm	BER = 1.55%	PER = 15.88%	SER1 = 13.44%	SER2 = 13.51%
Level = -80.1 dBm	BER = 0.28%	PER = 5.78%	SER1 = 5.47%	SER2 = 5.47%
Level = -78.1 dBm	BER = 0.03%	PER = 0.09%	SER1 = 0.09%	SER2 = 0.09%

J/S = -7.60 dB (SER = 0.09%)

Signal Freq = 2.432 GHz
Jammer Level = -85.7 dBm
Jammer Offset = +150 kHz

Level = -78.1 dBm	BER = 0.41%	PER = 13.58%	SER1 = 11.96%	SER2 = 12.16%
Level = -76.1 dBm	BER = 0.09%	PER = 0.42%	SER1 = 0.42%	SER2 = 0.42%
Level = -74.1 dBm	BER = 0.00%	PER = 0.00%	SER1 = 0.00%	SER2 = 0.00%
Level = -75.1 dBm	BER = 0.01%	PER = 0.02%	SER1 = 0.02%	SER2 = 0.02%
Level = -76.1 dBm	BER = 0.04%	PER = 0.41%	SER1 = 0.41%	SER2 = 0.41%
Level = -75.6 dBm	BER = 0.03%	PER = 0.10%	SER1 = 0.10%	SER2 = 0.10%

J/S = -10.10 dB (SER = 0.10%)

Signal Freq = 2.432 GHz
Jammer Level = -85.7 dBm
Jammer Offset = +200 kHz

Level = -75.6 dBm	BER = 0.26%	PER = 7.53%	SER1 = 7.00%	SER2 = 7.00%
Level = -73.6 dBm	BER = 0.02%	PER = 0.17%	SER1 = 0.17%	SER2 = 0.17%
Level = -71.6 dBm	BER = 0.00%	PER = 0.00%	SER1 = 0.00%	SER2 = 0.00%
Level = -72.6 dBm	BER = 0.00%	PER = 0.03%	SER1 = 0.03%	SER2 = 0.03%
Level = -73.6 dBm	BER = 0.02%	PER = 0.14%	SER1 = 0.14%	SER2 = 0.14%
Level = -73.1 dBm	BER = 0.01%	PER = 0.04%	SER1 = 0.04%	SER2 = 0.04%
Level = -73.3 dBm	BER = 0.01%	PER = 0.05%	SER1 = 0.05%	SER2 = 0.05%
Level = -73.5 dBm	BER = 0.03%	PER = 0.09%	SER1 = 0.09%	SER2 = 0.09%

J/S = -12.20 dB (SER = 0.09%)

Signal Freq = 2.432 GHz
Jammer Level = -85.7 dBm
Jammer Offset = +250 kHz

Level = -73.5 dBm BER = 0.25% PER = 3.58% SER1 = 3.46% SER2 = 3.46%
Level = -71.5 dBm BER = 0.01% PER = 0.03% SER1 = 0.03% SER2 = 0.03%
Level = -72.5 dBm BER = 0.06% PER = 0.57% SER1 = 0.57% SER2 = 0.57%
Level = -72.0 dBm BER = 0.02% PER = 0.12% SER1 = 0.12% SER2 = 0.12%
Level = -71.5 dBm BER = 0.01% PER = 0.04% SER1 = 0.04% SER2 = 0.04%
Level = -71.7 dBm BER = 0.01% PER = 0.05% SER1 = 0.05% SER2 = 0.05%
Level = -71.9 dBm BER = 0.02% PER = 0.10% SER1 = 0.10% SER2 = 0.10%

J/S = -14.00 dB (SER = 0.05%)

Signal Freq = 2.432 GHz
Jammer Level = -85.7 dBm
Jammer Offset = +300 kHz

Level = -71.7 dBm BER = 0.08% PER = 0.10% SER1 = 0.10% SER2 = 0.10%

J/S = -14.00 dB (SER = 0.10%)

Signal Freq = 2.432 GHz
Jammer Level = -85.7 dBm
Jammer Offset = +350 kHz

Level = -71.7 dBm BER = 0.25% PER = 1.43% SER1 = 1.41% SER2 = 1.41%
Level = -69.7 dBm BER = 0.02% PER = 0.03% SER1 = 0.02% SER2 = 0.02%
Level = -70.7 dBm BER = 0.08% PER = 0.14% SER1 = 0.14% SER2 = 0.14%
Level = -70.2 dBm BER = 0.03% PER = 0.74% SER1 = 0.74% SER2 = 0.74%
Level = -69.7 dBm BER = 0.02% PER = 0.02% SER1 = 0.02% SER2 = 0.02%
Level = -69.9 dBm BER = 0.02% PER = 0.03% SER1 = 0.02% SER2 = 0.02%
Level = -70.1 dBm BER = 0.03% PER = 0.03% SER1 = 0.03% SER2 = 0.03%
Level = -70.3 dBm BER = 0.03% PER = 0.06% SER1 = 0.06% SER2 = 0.06%
Level = -70.5 dBm BER = 0.06% PER = 0.13% SER1 = 0.13% SER2 = 0.13%

J/S = -15.40 dB (SER = 0.06%)

Signal Freq = 2.432 GHz
Jammer Level = -85.7 dBm
Jammer Offset = +400 kHz

Level = -70.3 dBm BER = 0.07% PER = 0.05% SER1 = 0.05% SER2 = 0.05%
Level = -72.3 dBm BER = 1.28% PER = 4.62% SER1 = 4.42% SER2 = 4.42%
Level = -71.3 dBm BER = 0.24% PER = 0.48% SER1 = 0.47% SER2 = 0.47%
Level = -70.3 dBm BER = 0.06% PER = 0.06% SER1 = 0.06% SER2 = 0.06%
Level = -70.8 dBm BER = 0.12% PER = 0.15% SER1 = 0.15% SER2 = 0.15%
Level = -70.6 dBm BER = 0.11% PER = 0.08% SER1 = 0.08% SER2 = 0.08%

J/S = -15.10 dB (SER = 0.08%)

Signal Freq = 2.432 GHz
Jammer Level = -85.7 dBm
Jammer Offset = +450 kHz

Level = -70.6 dBm BER = 0.17% PER = 0.11% SER1 = 0.11% SER2 = 0.11%
Level = -68.6 dBm BER = 0.01% PER = 0.00% SER1 = 0.00% SER2 = 0.00%
Level = -69.6 dBm BER = 0.04% PER = 0.00% SER1 = 0.00% SER2 = 0.00%

Level = -70.6 dBm BER = 0.17% PER = 0.08% SER1 = 0.07% SER2 = 0.07%
Level = -71.6 dBm BER = 0.60% PER = 0.70% SER1 = 0.69% SER2 = 0.69%
Level = -71.1 dBm BER = 0.31% PER = 0.30% SER1 = 0.29% SER2 = 0.29%
Level = -70.6 dBm BER = 0.19% PER = 0.11% SER1 = 0.11% SER2 = 0.11%
Level = -70.1 dBm BER = 0.09% PER = 0.03% SER1 = 0.02% SER2 = 0.02%
Level = -70.3 dBm BER = 0.10% PER = 0.05% SER1 = 0.05% SER2 = 0.05%
Level = -70.5 dBm BER = 0.16% PER = 0.06% SER1 = 0.06% SER2 = 0.06%
Level = -70.7 dBm BER = 0.20% PER = 0.05% SER1 = 0.05% SER2 = 0.05%
Level = -70.9 dBm BER = 0.26% PER = 0.15% SER1 = 0.15% SER2 = 0.15%

J/S = -15.10 dB (SER = 0.07%)

Signal Freq = 2.432 GHz
Jammer Level = -85.7 dBm
Jammer Offset = +500 kHz

Level = -68.7 dBm BER = 0.01% PER = 0.00% SER1 = 0.00% SER2 = 0.00%
Level = -70.7 dBm BER = 0.12% PER = 0.19% SER1 = 0.19% SER2 = 0.19%
Level = -69.7 dBm BER = 0.03% PER = 0.01% SER1 = 0.01% SER2 = 0.01%
Level = -70.2 dBm BER = 0.07% PER = 0.12% SER1 = 0.12% SER2 = 0.12%
Level = -70.0 dBm BER = 0.04% PER = 0.06% SER1 = 0.06% SER2 = 0.06%

J/S = -15.70 dB (SER = 0.06%)