



SAR TEST REPORT (WLAN)

REPORT NO.: SA980116L05

MODEL NO.: RHOD500

RECEIVED: Feb. 05, 2009

TESTED: Apr. 06, 2009

ISSUED: Apr. 16, 2009

APPLICANT: HTC Corporation

ADDRESS: No. 23, Xinghua Rd., Taoyuan City, 330, Taiwan,
R.O.C.

ISSUED BY: Bureau Veritas Consumer Products Services (H.K.)
Ltd., Taoyuan Branch

LAB ADDRESS: No. 47, 14th Ling, Chia Pau Tsuen, Lin Kou Hsiang,
Taipei Hsien 244, Taiwan, R.O.C.

TEST LOCATION: No. 19, Hwa Ya 2nd Rd, Wen Hwa Tsuen, Kwei
Shan Hsiang, Taoyuan Hsien 333, Taiwan, R.O.C.

This test report consists of 41 pages in total except Appendix. It may be duplicated completely for legal use with the approval of the applicant. It should not be reproduced except in full, without the written approval of our laboratory. The client should not use it to claim product endorsement by TAF or any government agencies. The test results in the report only apply to the tested sample.





TABLE OF CONTENTS

- 1. CERTIFICATION 3
- 2. GENERAL INFORMATION.....4
- 2.1 GENERAL DESCRIPTION OF EUT4
- 2.2 GENERAL DESCRIPTION OF APPLIED STANDARDS6
- 2.3 GENERAL INFORMATION OF THE SAR SYSTEM7
- 2.4 GENERAL DESCRIPTION OF THE SPATIAL PEAK SAR EVALUATION 10
- 3. DESCRIPTION OF SUPPORT UNITS 13
- 4. DESCRIPTION OF TEST MODES AND CONFIGURATIONS 14
- 4.1. DESCRIPTION OF TEST MODE 14
- 4.2. DESCRIPTION OF ASSESSMENT POSITION 15
- 4.3. SUMMARY OF TEST RESULTS 15
- 5. TEST RESULTS 16
- 5.1 TEST PROCEDURES 16
- 5.2 MEASURED SAR RESULTS 18
- 5.3 SAR LIMITS.....24
- 5.4 RECIPES FOR TISSUE SIMULATING LIQUIDS25
- 5.5 TEST EQUIPMENT FOR TISSUE PROPERTY28
- 6. SYSTEM VALIDATION 29
- 6.1 TEST EQUIPMENT 29
- 6.2 TEST PROCEDURE 30
- 6.3 VALIDATION RESULTS 32
- 6.4 SYSTEM VALIDATION UNCERTAINTIES 33
- 7. MEASUREMENT SAR PROCEDURE UNCERTAINTIES..... 34
- 7.1. PROBE CALIBRATION UNCERTAINTY 34
- 7.2. ISOTROPY UNCERTAINTY 35
- 7.3. BOUNDARY EFFECT UNCERTAINTY..... 35
- 7.4. PROBE LINEARITY UNCERTAINTY 36
- 7.5. READOUT ELECTRONICS UNCERTAINTY 36
- 7.6. RESPONSE TIME UNCERTAINTY 36
- 7.7. INTEGRATION TIME UNCERTAINTY 37
- 7.8. PROBE POSITIONER MECHANICAL TOLERANCE 38
- 7.9. PROBE POSITIONING 38
- 7.10. PHANTOM UNCERTAINTY 39
- 7.11. DASY4 UNCERTAINTY BUDGET 40
- 8. INFORMATION ON THE TESTING LABORATORIES 41

- APPENDIX A: TEST CONFIGURATIONS AND TEST DATA
- APPENDIX B: ADT SAR MEASUREMENT SYSTEM
- APPENDIX C: PHOTOGRAPHS OF SYSTEM VALIDATION
- APPENDIX D: SYSTEM CERTIFICATE & CALIBRATION



A D T

1. CERTIFICATION

PRODUCT: Pocket PC Phone
MODEL: RHOD500
APPLICANT: HTC Corporation
TESTED: Apr. 06, 2009
TEST SAMPLE: ENGINEERING SAMPLE
STANDARDS: **FCC Part 2 (Section 2.1093)**
FCC OET Bulletin 65, Supplement C (01-01)
RSS-102

The above equipment (model: RHOD500) has been tested by **Bureau Veritas Consumer Products Services (H.K.) Ltd., Taoyuan Branch**, and found compliance with the requirement of the above standards. The test record, data evaluation & Equipment Under Test (EUT) configurations represented herein are true and accurate accounts of the measurements of the sample's EMC characteristics under the conditions specified in this report.

PREPARED BY : Andrea Hsia , **DATE:** Apr. 16, 2009
Andrea Hsia / Specialist

TECHNICAL ACCEPTANCE : Long Chen , **DATE:** Apr. 16, 2009
Responsible for RF Long Chen / Senior Engineer

APPROVED BY : Gary Chang , **DATE:** Apr. 16, 2009
Gary Chang / Assistant Manager



2. GENERAL INFORMATION

2.1 GENERAL DESCRIPTION OF EUT

EUT	Pocket PC Phone
MODEL NO.	RHOD500
FCC ID	NM8RHOD500
POWER SUPPLY	3.7Vdc from rechargeable lithium battery 5.0Vdc from power adapter 5.0Vdc from host equipment
MODULATION TYPE	CCK, DQPSK, DBPSK for DSSS 64QAM, 16QAM, QPSK, BPSK for OFDM
RADIO TECHNOLOGY	DSSS, OFDM
TRANSFER RATE	802.11b: 11/5.5/2/1Mbps 802.11g: 54/48/36/24/18/12/9/6Mbps
OPERATING FREQUENCY	2412MHz ~ 2462MHz
NUMBER OF CHANNEL	11
CHANNEL FREQUENCIES UNDER TEST AND ITS CONDUCTED OUTPUT POWER	802.11b: 127.350mW / Ch6: 2437MHz 802.11g: 201.837mW / Ch6: 2437MHz
AVERAGE SAR (1g)	Head: 802.11b: 0.093W/kg 802.11g: 0.079W/kg
	Body: 802.11b: 0.198W/kg 802.11g: 0.169W/kg
ANTENNA TYPE	PIFA antenna with 1dBi gain
DATA CABLE	1.25m non-shielded USB cable without core (Brand: MEC & ACON)
I/O PORTS	Refer to user's manual
ACCESSORY DEVICES	Adapter, Battery

NOTE:

1. The EUT is a Pocket PC Phone. The functions of EUT listed as below:

	REFERENCE REPORT
CDMA 850 + CDMA 1900	SA980116L05-1
WLAN 802.11b/g	SA980116L05
BLUETOOTH	SA980116L05-2

2. The following accessory is for support units only.

PRODUCT	MODEL	DESCRIPTION
Earphone	HS G335	3.5mm connector 1.3m non-shielded without core

3. The EUT uses following LCM panels.

PRODUCT	BRAND	MODEL
LCM (Main)	Auo	H361VL01
LCM (2nd source)	EID	L4F00390T00
LCM (3rd source)	Sharp	LS036Y1LX01

**LCM (Main) was found to be the worst case and was selected for the final test configuration.



4. The EUT uses following Cameras.

PRODUCT	BRAND	MODEL
Camera (Main)	FOXCONN	3M-AF
Camera (2nd source)	LITEON	08PM17

** Camera (Main) was found to be the worst case and was selected for the final test configuration.

5. For USB cable, after pre-tested found brand: ACON was the worst therefore chosen for the final test and presented in the test report.

6. The EUT uses following batteries.

BATTERY 1: (MANUFACTORY: WELLDONE)	
BRAND	hTC
MODEL	RHOD160
RATING	3.7Vdc, 1500mAh, 5.55Whr

BATTERY 2: (MANUFACTORY: FORMOSA)	
BRAND	hTC
MODEL	RHOD160
RATING	3.7Vdc, 1500mAh, 5.55Whr

BATTERY 3: (MANUFACTORY: SIMPLO)	
BRAND	hTC
MODEL	RHOD160
RATING	3.7Vdc, 1500mAh, 5.55Whr

**After pre-tested, battery 1 was the worst case for the final test and presented in the test report.

7. The EUT were operated with following power adapters:

ADAPTER 1 (MANUFACTORY: Delta)	
BRAND	hTC
MODEL	TC P300
INPUT	100-240Vac, 0.2A, 50-60Hz
OUTPUT	5Vdc, 1A
POWER LINE	1.25m non-shielded cable without core

ADAPTER 2 (MANUFACTORY: Foxlink) (second source)	
BRAND	hTC
MODEL	TC P300
INPUT	100-240Vac, 0.2A, 50-60Hz
OUTPUT	5Vdc, 1A
POWER LINE	1.25m non-shielded cable without core

8. The EUT used the same antenna for Wireless LAN & Bluetooth function, but the two functions CAN NOT be used at the same time.

9. The above EUT information was declared by manufacturer and for more detailed features description, please refer to the manufacturer's specifications or User's Manual.



A D T

2.2 GENERAL DESCRIPTION OF APPLIED STANDARDS

According to the specifications of the manufacturer, this product must comply with the requirements of the following standards:

FCC Part 2 (2.1093)

FCC OET Bulletin 65, Supplement C (01- 01)

RSS-102

All test items have been performed and recorded as per the above standards.



2.3 GENERAL INFORMATION OF THE SAR SYSTEM

DASY4 (**software 4.7 Build 80**) consists of high precision robot, probe alignment sensor, phantom, robot controller, controlled measurement server and near-field probe. The robot includes six axes that can move to the precision position of the DASY4 software defined. The DASY4 software can define the area that is detected by the probe. The robot is connected to controlled box. Controlled measurement server is connected to the controlled robot box. The DAE includes amplifier, signal multiplexing, AD converter, offset measurement and surface detection. It is connected to the Electro-optical coupler (ECO). The ECO performs the conversion from the optical into digital electric signal of the DAE and transfers data to the PC.

EX3DV3 ISOTROPIC E-FIELD PROBE

CONSTRUCTION	Symmetrical design with triangular core Built-in shielding against static charges PEEK enclosure material (resistant to organic solvents, e.g., DGBE)
FREQUENCY	10 MHz to > 6 GHz Linearity: ± 0.2 dB (30 MHz to 6 GHz)
DIRECTIVITY	± 0.3 dB in HSL (rotation around probe axis) ± 0.5 dB in tissue material (rotation normal to probe axis)
DYNAMIC RANGE	$10 \mu\text{W/g}$ to > 100 mW/g Linearity: ± 0.2 dB (noise: typically < $1 \mu\text{W/g}$)
DIMENSIONS	Overall length: 330 mm (Tip: 20 mm) Tip diameter: 2.5 mm (Body: 12 mm) Typical distance from probe tip to dipole centers: 1 mm
APPLICATION	High precision dosimetric measurements in any exposure scenario (e.g., very strong gradient fields). Only probe which enables compliance testing for frequencies up to 6 GHz with precision of better 30%.

NOTE

1. The Probe parameters have been calibrated by the SPEAG. Please reference "APPENDIX D" for the Calibration Certification Report.
2. For frequencies above 800MHz, calibration in a rectangular wave-guide is used, because wave-guide size is manageable.
3. For frequencies below 800MHz, temperature transfer calibration is used because the wave-guide size becomes relatively large.



TWIN SAM V4.0

CONSTRUCTION

The shell corresponds to the specifications of the Specific Anthropomorphic Mannequin (SAM) phantom defined in IEEE 1528-2003, EN 62209-1 and IEC 62209. It enables the dosimetric evaluation of left and right hand phone usage as well as body mounted usage at the flat phantom region. A cover prevents evaporation of the liquid. Reference markings on the phantom allow the complete setup of all predefined phantom positions and measurement grids by manually teaching three points with the robot.

SHELL THICKNESS

$2 \pm 0.2\text{mm}$

FILLING VOLUME

Approx. 25liters

DIMENSIONS

Height: 810mm; Length: 1000mm; Width: 500mm

SYSTEM VALIDATION KITS:

CONSTRUCTION

Symmetrical dipole with 1/4 balun enables measurement of feedpoint impedance with NWA matched for use near flat phantoms filled with brain simulating solutions. Includes distance holder and tripod adaptor

CALIBRATION

Calibrated SAR value for specified position and input power at the flat phantom in brain simulating solutions

FREQUENCY

2450MHz

RETURN LOSS

> 20dB at specified validation position

POWER CAPABILITY

> 100W ($f < 1\text{GHz}$); > 40W ($f > 1\text{GHz}$)

OPTIONS

Dipoles for other frequencies or solutions and other calibration conditions upon request



DEVICE HOLDER FOR SAM TWIN PHANTOM

CONSTRUCTION

The device holder for the mobile phone device is designed to cope with different positions given in the standard. It has two scales for the device rotation (with respect to the body axis) and the device inclination (with respect to the line between the ear reference points). The rotation centers for both scales is the ear reference point (ERP). Thus the device needs no repositioning when changing the angles. The holder has been made out of low-loss POM material having the following dielectric parameters: relative permittivity $\varepsilon = 3$ and loss tangent $\delta = 0.02$. The amount of dielectric material has been reduced in the closest vicinity of the device, since measurements have suggested that the influence of the clamp on the test results could thus be lowered. The device holder for the portable device makes up of the polyethylene foam. The dielectric parameters of material close to the dielectric parameters of the air.

DATA ACQUISITION ELECTRONICS

CONSTRUCTION

The data acquisition electronics (DAE3) consists of a highly sensitive electrometer grade preamplifier with auto-zeroing, a channel and gain-switching multiplex, a fast 16 bit AD converter and a command decoder and control logic unit. Transmission to the measurement server is accomplished through an optical downlink for data and status information as well as an optical uplink for commands and the clock. The mechanical probe is mounting device includes two different sensor systems for frontal and sideways probe contacts. They are used for mechanical surface detection and probe collision detection. The input impedance of the DAE3 box is 200M Ω ; the inputs are symmetrical and floating. Common mode rejection is above 80 dB.



2.4 GENERAL DESCRIPTION OF THE SPATIAL PEAK SAR EVALUATION

The DASY4 post-processing software (SEMCAD) automatically executes the following procedures to calculate the field units from the micro-volt readings at the probe connector. The parameters used in the evaluation are stored in the configuration modules of the software:

Probe parameters:	- Sensitivity	Norm _i , a _{i0} , a _{i1} , a _{i2}
	- Conversion factor	ConvF _i
	- Diode compression point	dcp _i
Device parameters:	- Frequency	F
	- Crest factor	Cf
Media parameters:	- Conductivity	σ
	- Density	ρ

The first step of the evaluation is a linearization of the filtered input signal to account for the compression characteristics of the detector diode. The compensation depends on the input signal, the diode type and the DC-transmission factor from the diode to the evaluation electronics. If the exciting field is pulsed, the crest factor of the signal must be known to correctly compensate for peak power. The formula for each channel can be given as:

$$V_i = U_i + U_i^2 \cdot \frac{cf}{dcp_i}$$

V _i	=compensated signal of channel i	(i = x, y, z)
U _i	=input signal of channel I	(i = x, y, z)
Cf	=crest factor of exciting field	(DASY parameter)
dcp _i	=diode compression point	(DASY parameter)



From the compensated input signals the primary field data for each channel can be evaluated:

$$\text{E-field probes: } E_i = \sqrt{\frac{V_i}{\text{Norm}_i \cdot \text{ConvF}}}$$

$$\text{H-field probes: } H_i = \sqrt{V_i} \cdot \frac{a_{i0} + a_{i1}f + a_{i2}f^2}{f}$$

V_i	= compensated signal of channel i	(i = x, y, z)
Norm_i	= sensor sensitivity of channel i $\mu\text{V}/(\text{V/m})^2$ for E-field Probes	(i = x, y, z)
ConvF	= sensitivity enhancement in solution	
a_{ij}	= sensor sensitivity factors for H-field probes	
f	= carrier frequency [GHz]	
E_i	= electric field strength of channel i in V/m	
H_i	= magnetic field strength of channel i in A/m	

The RSS value of the field components gives the total field strength (Hermitian magnitude):

$$E_{tot} = \sqrt{E_x^2 + E_y^2 + E_z^2}$$

The primary field data are used to calculate the derived field units.

$$SAR = E_{tot}^2 \cdot \frac{\sigma}{\rho \cdot 1'000}$$

SAR	= local specific absorption rate in mW/g
E_{tot}	= total field strength in V/m
σ	= conductivity in [mho/m] or [Siemens/m]
ρ	= equivalent tissue density in g/cm ³



Note that the density is set to 1, to account for actual head tissue density rather than the density of the tissue simulating liquid. The entire evaluation of the spatial peak values is performed within the Post-processing engine (SEMCAD). The system always gives the maximum values for the 1g and 10g cubes. The algorithm to find the cube with highest averaged SAR is divided into the following stages:

1. The extraction of the measured data (grid and values) from the Zoom Scan
2. The calculation of the SAR value at every measurement point based on all stored data (A/D values and measurement parameters)
3. The generation of a high-resolution mesh within the measured volume
4. The interpolation of all measured values from the measurement grid to the high-resolution grid
5. The extrapolation of the entire 3-D field distribution to the phantom surface over the distance from sensor to surface
6. The calculation of the averaged SAR within masses of 1g and 10g.

The probe is calibrated at the center of the dipole sensors that is located 1 to 2.7mm away from the probe tip. During measurements, the probe stops shortly above the phantom surface, depending on the probe and the surface detecting system. Both distances are included as parameters in the probe configuration file. The software always knows exactly how far away the measured point is from the surface. As the probe cannot directly measure at the surface, the values between the deepest measured point and the surface must be extrapolated. The angle between the probe axis and the surface normal line is less than 30 degree.

The maximum search is automatically performed after each area scan measurement. It is based on splines in two or three dimensions. The procedure can find the maximum for most SAR distributions even with relatively large grid spacing. After the area scanning measurement, the probe is automatically moved to a position at the interpolated maximum. The following scan can directly use this position for reference, e.g., for a finer resolution grid or the cube evaluations. The 1g and 10g peak evaluations are only available for the predefined cube 7 x 7 x 7 scans. The routines are verified and optimized for the grid dimensions used in these cube measurements. The measured volume of 30 x 30 x 30mm contains about 30g of tissue. The first procedure is an extrapolation (incl. boundary correction) to get the points between the lowest measured plane and the surface. The next step uses 3D interpolation to get all points within the measured volume in a 1mm grid (42875 points). In the last



A D T

step, a 1g cube is placed numerically into the volume and its averaged SAR is calculated. This cube is then moved around until the highest averaged SAR is found. If the highest SAR is found at the edge of the measured volume, the system will issue a warning: higher SAR values might be found outside of the measured volume. In that case the cube measurement can be repeated, using the new interpolated maximum as the center.

3. DESCRIPTION OF SUPPORT UNITS

The EUT has been tested as an independent unit.

4. DESCRIPTION OF TEST MODES AND CONFIGURATIONS

4.1. DESCRIPTION OF TEST MODE

TEST MODE	COMMUNICATION MODE	MODULATION TYPE	ASSESSMENT POSTITION	TESTED CHANNEL	REMARK
1	802.11b	DBPSK	A / Cheek	6	-
2		DBPSK	A / Tilt	6	-
3		DBPSK	B / Cheek	6	-
4		DBPSK	B / Tilt	6	-
5		DBPSK	C : Body / Bottom	6	Slider off
6		DBPSK	C : Body / Front	6	Slider off
7		DBPSK	C : Body / Bottom	6	Slider on
8		DBPSK	C : Body / Front	6	Slider on
9	802.11g	BPSK	A / Cheek	6	-
10		BPSK	A / Tilt	6	-
11		BPSK	B / Cheek	6	-
12		BPSK	B / Tilt	6	-
13		BPSK	C : Body / Bottom	6	Slider off
14		BPSK	C : Body / Front	6	Slider off
15		BPSK	C : Body / Bottom	6	Slider on
16		BPSK	C : Body / Front	6	Slider on

Note: The Body position to the phantom with 15mm-separation distance.



4.2. DESCRIPTION OF ASSESSMENT POSITION

Assessment position A: Right head position, B: Left head position, C: Body position, please refer to appendix E for the photo.

4.3. SUMMARY OF TEST RESULTS

PART OF ASSESSMENT		HEAD POSITION				BODY POSITION			
COMMUNICATION MODE		802.11b							
TEST MODE		1	2	3	4	5	6	7	8
		MEASURED VALUE OF 1g SAR (W/kg)							
		RIGHT		LEFT		BOTTOM	FRONT	BOTTOM	FRONT
Chan.	Freq. (MHz)	CHEEK	TILT	CHEEK	TILT				
6	2437 (Mid.)	0.093	0.026	0.055	0.023	0.193	0.022	0.198	0.026

NOTE: The worst value has been marked by boldface.

PART OF ASSESSMENT		HEAD POSITION				BODY POSITION			
COMMUNICATION MODE		802.11g							
TEST MODE		9	10	11	12	13	14	15	16
		MEASURED VALUE OF 1g SAR (W/kg)							
		RIGHT		LEFT		BOTTOM	FRONT	BOTTOM	FRONT
Chan.	Freq. (MHz)	CHEEK	TILT	CHEEK	TILT				
6	2437 (Mid.)	0.079	0.024	0.049	0.020	0.169	0.013	0.162	0.012

NOTE: The worst value has been marked by boldface.



5. TEST RESULTS

5.1 TEST PROCEDURES

Use the software to control the EUT channel and transmission power. Then record the conducted power before the testing. Place the EUT to the specific test location. After the testing, must writing down the conducted power of the EUT into the report. The SAR value was calculated via the 3D spline interpolation algorithm that has been implemented in the software of DASY4 SAR measurement system manufactured and calibrated by SPEAG. According to the IEEE 1528 standards, the recommended procedure for assessing the peak spatial-average SAR value consists of the following steps:

- Power reference measurement
- Verification of the power reference measurement
- Area scan
- Zoom scan
- Power reference measurement

The area scan was performed for the highest spatial SAR location. The zoom scan with 30mm x 30mm x 30mm volume was performed for SAR value averaged over 1g and 10g spatial volumes.

In the zoom scan, the distance between the measurement point at the probe sensor location (geometric center behind the probe tip) and the phantom surface is 3.0mm and maintained at a constant distance of ± 1.0 mm during a zoom scan to determine peak SAR locations. The distance is 3mm between the first measurement point and the bottom surface of the phantom. The secondary measurement point to the bottom surface of the phantom is with 9mm separation distance. The cube size is 7 x 7 x 7 points consist of 343 points and the grid space is 5mm.



The measurement time is 0.5s at each point of the zoom scan. The probe boundary effect compensation shall be applied during the SAR test. Because of the tip of the probe to the Phantom surface separated distances are longer than half a tip probe diameter.

In the area scan, the separation distance is 3mm between the each measurement point and the phantom surface. The scan size shall be included the transmission portion of the EUT. The measurement time is the same as the zoom scan. At last the reference power drift shall be less than $\pm 5\%$.



5.2 MEASURED SAR RESULTS

WLAN (802.11b) BAND RIGHT HEAD POSITION

ENVIRONMENTAL CONDITION		Air Temperature : 22.3°C, Liquid Temperature : 21.2°C Humidity : 62%RH						
TESTED BY		Sam Onn			DATE		Apr. 06, 2009	
CHAN.	FREQ. (MHz)	TEST MODE	CONDUCTED POWER (mW)		POWER DRIFT (%)	DEVICE TEST POSITION MODE	MEASURED 1g SAR (W/kg)	
			BEGIN TEST	AFTER TEST				
6	2437 (Mid.)	802.11b	127.350	126.446	-0.71	1	0.093	
6	2437 (Mid.)	802.11b	127.350	126.280	-0.84	2	0.026	

NOTE:

1. Test configuration of each mode is described in section 4.2.
2. In this testing, the limit for General Population Spatial Peak averaged over 1g, **1.6 W/kg**, is applied.
3. Please see the Appendix A for the data.
4. The variation of the EUT conducted power measured before and after SAR testing should not over 5%.



A D T

WLAN (802.11b) BAND LEFT HEAD POSITION

ENVIRONMENTAL CONDITION		Air Temperature : 22.3°C, Liquid Temperature : 21.2°C Humidity : 62%RH						
TESTED BY		Sam Onn			DATE		Apr. 06, 2009	
CHAN.	FREQ. (MHz)	TEST MODE	CONDUCTED POWER (mW)		POWER DRIFT (%)	DEVICE TEST POSITION MODE	MEASURED 1g SAR (W/kg)	
			BEGIN TEST	AFTER TEST				
6	2437 (Mid.)	802.11b	127.350	126.178	-0.92	3	0.055	
6	2437 (Mid.)	802.11b	127.350	126.051	-1.02	4	0.023	

NOTE:

1. Test configuration of each mode is described in section 4.2.
2. In this testing, the limit for General Population Spatial Peak averaged over 1g, **1.6 W/kg**, is applied.
3. Please see the Appendix A for the data.
4. The variation of the EUT conducted power measured before and after SAR testing should not over 5%.



A D T

WLAN (802.11b) BAND BODY POSITION

ENVIRONMENTAL CONDITION		Air Temperature : 22.6°C, Liquid Temperature : 21.3°C Humidity : 63%RH					
TESTED BY		Sam Onn			DATE		Apr. 06, 2009
CHAN.	FREQ. (MHz)	TEST MODE	CONDUCTED POWER (mW)		POWER DRIFT (%)	DEVICE TEST POSITION MODE	MEASURED 1g SAR (W/kg)
			BEGIN TEST	AFTER TEST			
6	2437 (Mid.)	802.11b	127.350	125.962	-1.09	5	0.193
6	2437 (Mid.)	802.11b	127.350	125.911	-1.13	6	0.022
6	2437 (Mid.)	802.11b	127.350	125.821	-1.20	7	0.198
6	2437 (Mid.)	802.11b	127.350	125.707	-1.29	8	0.026

NOTE:

1. Test configuration of each mode is described in section 4.2.
2. In this testing, the limit for General Population Spatial Peak averaged over 1g, **1.6 W/kg**, is applied.
3. Please see the Appendix A for the data.
4. The variation of the EUT conducted power measured before and after SAR testing should not over 5%.



WLAN (802.11g) BAND RIGHT HEAD POSITION

ENVIRONMENTAL CONDITION		Air Temperature : 22.3°C, Liquid Temperature : 21.2°C Humidity : 62%RH						
TESTED BY		Sam Onn			DATE		Apr. 06, 2009	
CHAN.	FREQ. (MHz)	TEST MODE	CONDUCTED POWER (mW)		POWER DRIFT (%)	DEVICE TEST POSITION MODE	MEASURED 1g SAR (W/kg)	
			BEGIN TEST	AFTER TEST				
6	2437 (Mid.)	802.11g	201.837	199.092	-1.36	9	0.079	
6	2437 (Mid.)	802.11g	201.837	198.971	-1.42	10	0.024	

NOTE:

1. Test configuration of each mode is described in section 4.2.
2. In this testing, the limit for General Population Spatial Peak averaged over 1g, **1.6 W/kg**, is applied.
3. Please see the Appendix A for the data.
4. The variation of the EUT conducted power measured before and after SAR testing should not over 5%.



WLAN (802.11g) BAND LEFT HEAD POSITION

ENVIRONMENTAL CONDITION		Air Temperature : 22.3°C, Liquid Temperature : 21.2°C Humidity : 62%RH						
TESTED BY		Sam Onn			DATE		Apr. 06, 2009	
CHAN.	FREQ. (MHz)	TEST MODE	CONDUCTED POWER (mW)		POWER DRIFT (%)	DEVICE TEST POSITION MODE	MEASURED 1g SAR (W/kg)	
			BEGIN TEST	AFTER TEST				
6	2437 (Mid.)	802.11g	201.837	198.729	-1.54	11	0.049	
6	2437 (Mid.)	802.11g	201.837	198.567	-1.62	12	0.020	

NOTE:

1. Test configuration of each mode is described in section 4.2.
2. In this testing, the limit for General Population Spatial Peak averaged over 1g, **1.6 W/kg**, is applied.
3. Please see the Appendix A for the data.
4. The variation of the EUT conducted power measured before and after SAR testing should not over 5%.



A D T

WLAN (802.11g) BAND BODY POSITION

ENVIRONMENTAL CONDITION		Air Temperature : 22.6°C, Liquid Temperature : 21.3°C Humidity : 63%RH						
TESTED BY		Sam Onn			DATE		Apr. 06, 2009	
CHAN.	FREQ. (MHz)	TEST MODE	CONDUCTED POWER (mW)		POWER DRIFT (%)	DEVICE TEST POSITION MODE	MEASURED 1g SAR (W/kg)	
			BEGIN TEST	AFTER TEST				
6	2437 (Mid.)	802.11g	201.837	198.386	-1.71	13	0.169	
6	2437 (Mid.)	802.11g	201.837	198.184	-1.81	14	0.013	
6	2437 (Mid.)	802.11g	201.837	198.002	-1.90	15	0.162	
6	2437 (Mid.)	802.11g	201.837	197.699	-2.05	16	0.012	

NOTE:

1. Test configuration of each mode is described in section 4.2.
2. In this testing, the limit for General Population Spatial Peak averaged over 1g, **1.6 W/kg**, is applied.
3. Please see the Appendix A for the data.
4. The variation of the EUT conducted power measured before and after SAR testing should not over 5%.



5.3 SAR LIMITS

HUMAN EXPOSURE	SAR (W/kg)	
	(GENERAL POPULATION / UNCONTROLLED EXPOSURE ENVIRONMENT)	(OCCUPATIONAL / CONTROLLED EXPOSURE ENVIRONMENT)
Spatial Average (whole body)	0.08	0.4
Spatial Peak (averaged over 1 g)	1.6	8.0
Spatial Peak (hands / wrists / feet / ankles averaged over 10 g)	4.0	20.0

NOTE:

1. This limits accord to 47 CFR 2.1093 – Safety Limit.
2. The EUT property been complied with the partial body exposure limit under the general population environment.



5.4 RECIPES FOR TISSUE SIMULATING LIQUIDS

For the measurement of the field distribution inside the SAM phantom, the phantom must be filled with 25 liters of tissue simulation liquid.

The following ingredients are used :

- **WATER-** Deionized water (pure H₂O), resistivity ≈ 16 M - as basis for the liquid
- **SUGAR-** Refined sugar in crystals, as available in food shops - to reduce relative permittivity
- **SALT-** Pure NaCl - to increase conductivity
- **CELLULOSE-** Hydroxyethyl-cellulose, medium viscosity (75-125mPa.s, 2% in water, 20°C),
CAS # 54290 - to increase viscosity and to keep sugar in solution
- **PRESERVATIVE-** Preventol D-7 Bayer AG, D-51368 Leverkusen, CAS # 55965-84-9 - to prevent the spread of bacteria and molds
- **DGMBE-** Diethylenglycol-monobuthyl ether (DGMBE), Fluka Chemie GmbH, CAS # 112-34-5 - to reduce relative permittivity

THE RECIPES FOR 2450MHz SIMULATING LIQUID TABLE

INGREDIENT	HEAD SIMULATING LIQUID 2450MHz (HSL-2450)	MUSCLE SIMULATING LIQUID 2450MHz (MSL-2450)
Water	45%	69.83%
DGMBE	55%	30.17%
Salt	NA	NA
Dielectric Parameters at 22°C	f= 2450MHz $\epsilon = 39.2 \pm 5\%$ $\sigma = 1.80 \pm 5\%$ S/m	f= 2450MHz $\epsilon = 52.7 \pm 5\%$ $\sigma = 1.95 \pm 5\%$ S/m



Testing the liquids using the Agilent Network Analyzer E8358A and Agilent Dielectric Probe Kit 85070D. The testing procedure is following as

1. Turn Network Analyzer on and allow at least 30min. warm up.
2. Mount dielectric probe kit so that interconnecting cable to Network Analyzer will not be moved during measurements or calibration.
3. Pour de-ionized water and measure water temperature ($\pm 1^\circ$).
4. Set water temperature in Agilent-Software (Calibration Setup).
5. Perform calibration.
6. Validate calibration with dielectric material of known properties (e.g. polished ceramic slab with $>8\text{mm}$ thickness $\epsilon' = 10.0$, $\epsilon'' = 0.0$). If measured parameters do not fit within tolerance, repeat calibration (± 0.2 for ϵ' : ± 0.1 for ϵ'').
7. Conductivity can be calculated from ϵ'' by $\sigma = \omega \epsilon_0 \epsilon'' = \epsilon'' f [\text{GHz}] / 18$.
8. Measure liquid shortly after calibration. Repeat calibration every hour.
9. Stir the liquid to be measured. Take a sample ($\sim 50\text{ml}$) with a syringe from the center of the liquid container.
10. Pour the liquid into a small glass flask. Hold the syringe at the bottom of the flask to avoid air bubbles.
11. Put the dielectric probe in the glass flask. Check that there are no air bubbles in front of the opening in the dielectric probe kit.
12. Perform measurements.
13. Adjust medium parameters in DASY4 for the frequencies necessary for the measurements ('Setup Config', select medium (e.g. Brain 900MHz) and press 'Option'-button.
14. Select the current medium for the frequency of the validation (e.g. Setup Medium Brain 900MHz).



A D T

FOR WLAN 2.4GHz BAND SIMULATING LIQUID

LIQUID TYPE		HSL-2450		
SIMULATING LIQUID TEMP.		21.2		
TEST DATE		Apr. 06, 2009		
TESTED BY		Sam Onn		
FREQ. (MHz)	LIQUID PARAMETER	STANDARD VALUE	MEASUREMENT VALUE	ERROR PERCENTAGE (%)
2437	Permittivity (ϵ)	39.20	40.10	2.30
2450		39.20	40.00	2.04
2437	Conductivity (σ) S/m	1.79	1.78	-0.56
2450		1.80	1.79	-0.56
Dielectric Parameters Required at 22°C		f= 2450MHz $\epsilon= 39.2 \pm 5\%$ $\sigma= 1.80 \pm 5\%$ S/m		

LIQUID TYPE		MSL-2450		
SIMULATING LIQUID TEMP.		21.3		
TEST DATE		Apr. 06, 2009		
TESTED BY		Sam Onn		
FREQ. (MHz)	LIQUID PARAMETER	STANDARD VALUE	MEASUREMENT VALUE	ERROR PERCENTAGE (%)
2437	Permittivity (ϵ)	52.70	54.70	3.80
2450		52.70	54.60	3.61
2437	Conductivity (σ) S/m	1.94	1.93	-0.52
2450		1.95	1.95	0.00
Dielectric Parameters Required at 22°C		f= 2450MHz $\epsilon= 52.7 \pm 5\%$ $\sigma= 1.95 \pm 5\%$ S/m		



5.5 TEST EQUIPMENT FOR TISSUE PROPERTY

ITEM	NAME	BRAND	TYPE	SERIES NO.	DATE OF CALIBRATION	DUE DATE OF CALIBRATION
1	Network Analyzer	Agilent	E8358A	US41480538	Nov. 27, 2008	Nov. 26, 2009
2	Dielectric Probe	Agilent	85070D	US01440176	NA	NA

NOTE:

1. Before starting, all test equipment shall be warmed up for 30min.
2. The tolerance ($k=1$) specified by Agilent for general dielectric measurements, deriving from inaccuracies in the calibration data, analyzer drift, and random errors, are usually $\pm 2.5\%$ and $\pm 5\%$ for measured permittivity and conductivity, respectively. However, the tolerances for the conductivity is smaller for material with large loss tangents, i.e., less than $\pm 2.5\%$ ($k=1$). It can be substantially smaller if more accurate methods are applied.



6. SYSTEM VALIDATION

The system validation was performed in the flat phantom with equipment listed in the following table. Since the SAR value is calculated from the measured electric field, dielectric constant and conductivity of the body tissue and the SAR is proportional to the square of the electric field. So, the SAR value will be also proportional to the RF power input to the system validation dipole under the same test environment. In our system validation test, 250mW RF input power was used.

6.1 TEST EQUIPMENT

ITEM	NAME	BRAND	TYPE	SERIES NO.	DATE OF CALIBRATION	DUE DATE OF CALIBRATION
1	SAM Phantom	S & P	QD000 P40 CA	TP-1150	NA	NA
2	Signal Generator	Anritsu	68247B	984703	May 27, 2008	May 26, 2009
3	E-Field Probe	S & P	EX3DV3	3504	Jan. 20, 2009	Jan. 21, 2010
4	DAE	S & P	DAE	510	Jan. 22, 2009	Jan. 21. 2010
5	Robot Positioner	Staubli Unimation	NA	NA	NA	NA
6	Validation Dipole	S & P	D2450V2	737	Apr. 22, 2008	Apr. 21, 2009

NOTE: Before starting the measurement, all test equipment shall be warmed up for 30min.



6.2 TEST PROCEDURE

Before the system performance check, we need only to tell the system which components (probe, medium, and device) are used for the system performance check; the system will take care of all parameters. The dipole must be placed beneath the flat section of the SAM Twin Phantom with the correct distance holder in place. The distance holder should touch the phantom surface with a light pressure at the reference marking (little cross) and be oriented parallel to the long side of the phantom. Accurate positioning is not necessary, since the system will search for the peak SAR location, except that the dipole arms should be parallel to the surface. The device holder for mobile phones can be left in place but should be rotated away from the dipole.

1. The "Power Reference Measurement" and "Power Drift Measurement" jobs are located at the beginning and end of the batch process. They measure the field drift at one single point in the liquid over the complete procedure. The indicated drift is mainly the variation of the amplifier output power. If it is too high (above ± 0.1 dB), the system performance check should be repeated; some amplifiers have very high drift during warm-up. A stable amplifier gives drift results in the DASY system below ± 0.02 dB.
2. The "Surface Check" job tests the optical surface detection system of the DASY system by repeatedly detecting the surface with the optical and mechanical surface detector and comparing the results. The output gives the detecting heights of both systems, the difference between the two systems and the standard deviation of the detection repeatability. Air bubbles or refraction in the liquid due to separation of the sugar-water mixture gives poor repeatability (above ± 0.1 mm). In that case it is better to abort the system performance check and stir the liquid.



3. The "Area Scan" job measures the SAR above the dipole on a plane parallel to the surface. It is used to locate the approximate location of the peak SAR. The proposed scan uses large grid spacing for faster measurement; due to the symmetric field, the peak detection is reliable. If a finer graphic is desired, the grid spacing can be reduced. Grid spacing and orientation have no influence on the SAR result.
4. The "Zoom Scan" job measures the field in a volume around the peak SAR value assessed in the previous "Area Scan" job (for more information see the application note on SAR evaluation).

About the validation dipole positioning uncertainty, the constant and low loss dielectric spacer is used to establish the correct distance between the top surface of the dipole and the bottom surface of the phantom, the error component introduced by the uncertainty of the distance between the liquid (i.e., phantom shell) and the validation dipole in the DASY4 system is less than ± 0.1 mm.

$$SAR_{tolerance} [\%] = 100 \times \left(\frac{(a + d)^2}{a^2} - 1 \right)$$

As the closest distance is 10mm, the resulting tolerance $SAR_{tolerance} [\%]$ is $< 2\%$.



6.3 VALIDATION RESULTS

SYSTEM VALIDATION TEST OF SIMULATING LIQUID					
FREQUENCY (MHz)	REQUIRED SAR (mW/g)	MEASURED SAR (mW/g)	DEVIATION (%)	SEPARATION DISTANCE	TESTED DATE
HSL2450	14.00 (1g)	13.30	-5.00	10mm	Apr. 06, 2009
MSL2450	12.80 (1g)	12.70	-0.78	10mm	Apr. 06, 2009
TESTED BY	Sam Onn				

NOTE: Please see Appendix for the photo of system validation test.



6.4 SYSTEM VALIDATION UNCERTAINTIES

In the table below, the system validation uncertainty with respect to the analytically assessed SAR value of a dipole source as given in the IEEE 1528 standard is given. This uncertainty is smaller than the expected uncertainty for mobile phone measurements due to the simplified setup and the symmetric field distribution.

Error Description	Tolerance (±%)	Probability Distribution	Divisor	(C _i)		Standard Uncertainty (±%)		(v _i)
				(1g)	(10g)	(1g)	(10g)	
Measurement System								
Probe Calibration	5.50	Normal	1	1	1	5.50	5.50	∞
Axial Isotropy	4.70	Rectangular	√3	0.7	0.7	1.90	1.90	∞
Hemispherical Isotropy	9.60	Rectangular	√3	0.7	0.7	3.88	3.88	∞
Boundary effects	1.00	Rectangular	√3	1	1	0.58	0.58	∞
Linearity	4.70	Rectangular	√3	1	1	2.71	2.71	∞
System Detection Limits	1.00	Rectangular	√3	1	1	0.58	0.58	∞
Readout Electronics	0.30	Normal	1	1	1	0.30	0.30	∞
Response Time	0.80	Rectangular	√3	1	1	0.46	0.46	∞
Integration Time	2.60	Rectangular	√3	1	1	1.50	1.50	∞
RF Ambient Noise	3.00	Rectangular	√3	1	1	1.73	1.73	∞
RF Ambient Reflections	3.00	Rectangular	√3	1	1	1.73	1.73	∞
Probe Positioner	0.40	Rectangular	√3	1	1	0.23	0.23	∞
Probe Positioning	2.90	Rectangular	√3	1	1	1.67	1.67	∞
Max. SAR Eval.	1.00	Rectangular	√3	1	1	0.58	0.58	∞
Dipole Related								
Dipole Axis to Liquid Distance	2.00	Rectangular	√3	1	1	1.15	1.15	145
Input Power Drift	5.00	Rectangular	√3	1	1	2.89	2.89	∞
Phantom and Tissue parameters								
Phantom Uncertainty	4.00	Rectangular	√3	1	1	2.31	2.31	∞
Liquid Conductivity (target)	5.00	Rectangular	√3	0.64	0.43	1.85	1.24	∞
Liquid Conductivity (measurement)	2.10	Normal	1	0.64	0.43	1.34	0.90	∞
Liquid Permittivity (target)	5.00	Rectangular	√3	0.6	0.49	1.73	1.41	∞
Liquid Permittivity (measurement)	4.30	Normal	1	0.6	0.49	2.58	2.11	∞
Combined Standard Uncertainty						9.93	9.62	
Coverage Factor for 95%						Kp=2		
Expanded Uncertainty (K=2)						19.86	19.23	

NOTE: About the system validation uncertainty assessment, please reference the section 7.



7. MEASUREMENT SAR PROCEDURE UNCERTAINTIES

The assessment of spatial peak SAR of the hand held devices is according to IEEE 1528 / EN 62209-1. All testing situation shall be met below these requirements.

- The system is used by an experienced engineer who follows the manual and the guidelines taught during the training provided by SPEAG.
- The probe has been calibrated within the requested period and the stated uncertainty for the relevant frequency bands does not exceed 4.8% (k=1).
- The validation dipole has been calibrated within the requested period and the system performance check has been successful.
- The DAE unit has been calibrated within the within the requested period.
- The minimum distance between the probe sensor and inner phantom shell is selected to be between 4 and 5mm.
- The operational mode of the DUT is CW, CDMA, FDMA or TDMA (GSM, DCS, PCS, IS136 and PDC) and the measurement/integration time per point is >500 ms.
- The dielectric parameters of the liquid have been assessed using Agilent 85070D dielectric probe kit or a more accurate method.
- The dielectric parameters are within 5% of the target values.
- The DUT has been positioned as described in section 3.

7.1. PROBE CALIBRATION UNCERTAINTY

SPEAG conducts the probe calibration in compliance with international and national standards (e.g. IEEE 1528, EN 62209-1, IEC 62209, etc.) under ISO17025. The uncertainties are stated on the calibration certificate. For the most relevant frequency bands, these values do not exceed 4.8% (k=1). If evaluations of other bands are performed for which the uncertainty exceeds these values, the uncertainty tables given in the summary have to be revised accordingly.

7.2. ISOTROPY UNCERTAINTY

The axial isotropy tolerance accounts for probe rotation around its axis while the hemispherical isotropy error includes all probe orientations and field polarizations. These parameters are assessed by SPEAG during initial calibration. In 2001, SPEAG further tightened its quality controls and warrants that the maximal deviation from axial isotropy is $\pm 0.20\text{dB}$, while the maximum deviation of hemispherical isotropy is $\pm 0.40\text{dB}$, corresponding to $\pm 4.7\%$ and $\pm 9.6\%$, respectively. A weighting factor of c_p equal to 0.5 can be applied, since the axis of the probe deviates less than 30 degrees from the normal surface orientation.

7.3. BOUNDARY EFFECT UNCERTAINTY

The effect can be estimated according to the following error approximation formula

$$SAR_{tolerance} [\%] = SAR_{be} [\%] \times \frac{(d_{be} + d_{step})^2}{2d_{step}} e^{-\frac{d_{be}}{\delta/2}}$$

$$d_{be} + d_{step} < 10\text{mm}$$

The parameter d_{be} is the distance in mm between the surface and the closest measurement point used in the averaging process; d_{step} is the separation distance in mm between the first and second measurement points; δ is the minimum penetration depth in mm within the head tissue equivalent liquids (i.e., $\delta = 13.95\text{mm}$ at 3GHz); SAR_{be} is the deviation between the measured SAR value at the distance d_{be} from the boundary and the wave-guide analytical value SAR_{ref} . DASY4 applies a boundary effect compensation algorithm according to IEEE 1528, which is possible since the axis of the probe never deviates more than 30 degrees from the normal surface orientation. $SAR_{be}[\%]$ is assessed during the calibration process and SPEAG warrants that the uncertainty at distances larger than 4mm is always less than 1%. In summary, the worst case boundary effect SAR tolerance[%] for scanning distances larger than 4mm is $< \pm 0.8\%$.

7.4. PROBE LINEARITY UNCERTAINTY

Field probe linearity uncertainty includes errors from the assessment and compensation of the diode compression effects for CW and pulsed signals with known duty cycles. This error is assessed using the procedure described in IEEE 1528 / EN 62209-1. For SPEAG field probes, the measured difference between CW and pulsed signals, with pulse frequencies between 10Hz and 1kHz and duty cycles between 1 and 100, is $< \pm 0.20\text{dB}$ ($< \pm 4.7\%$).

7.5. READOUT ELECTRONICS UNCERTAINTY

All uncertainties related to the probe readout electronics (DAE unit), including the gain and linearity of the instrumentation amplifier, its loading effect on the probe, and accuracy of the signal conversion algorithm, have been assessed accordingly to IEEE 1528 / EN 62209-1. The combination (root-sum-square RSS method) of these components results in an overall maximum error of $\pm 1.0\%$.

7.6. RESPONSE TIME UNCERTAINTY

The time response of the field probes is assessed by exposing the probe to a well-controlled electric field producing SAR larger than 2.0W/kg at the tissue medium surface. The signal response time is evaluated as the time required by the system to reach 90% of the expected final value after an on/of switch of the power source. Analytically, it can be expressed as:

$$SAR_{tolerance} [\%] = 100 \times \left(\frac{T_m}{T_m + \tau e^{-T_m/\tau} - \tau} - 1 \right)$$

where T_m is 500 ms, i.e., the time between measurement samples, and τ the time constant. The response time τ of SPEAG's probes is $< 5\text{ms}$. In the current implementation, DASY4 waits longer than 100 ms after having reached the grid point before starting a measurement, i.e., the response time uncertainty is negligible.

7.7. INTEGRATION TIME UNCERTAINTY

If the device under test does not emit a CW signal, the integration time applied to measure the electric field at a specific point may introduce additional uncertainties due to the discretization and can be assessed as follows

$$SAR_{tolerance} [\%] = 100 \times \sum_{all\ sub-frames} \frac{t_{frame}}{t_{integration}} \frac{slot_{idle}}{slot_{total}}$$

The tolerances for the different systems are given in Table 7.1, whereby the worst-case $SAR_{tolerance}$ is 2.6%.

System	$SAR_{tolerance} \%$
CW	0
CDMA*	0
WCDMA*	0
FDMA	0
IS-136	2.6
PDC	2.6
GSM/DCS/PCS	1.7
DECT	1.9
Worst-Case	2.6

TABLE 7.1

7.8. PROBE POSITIONER MECHANICAL TOLERANCE

The mechanical tolerance of the field probe positioner can introduce probe positioning uncertainties. The resulting SAR uncertainty is assessed by comparing the SAR obtained according to the specifications of the probe positioner with respect to the actual position defined by the geometric center of the probe sensors. The tolerance is determined as:

$$SAR_{tolerance} [\%] = 100 \times \frac{d_{ph}}{\delta/2}$$

The specified repeatability of the RX robot family used in DASY4 systems is $\pm 25\mu\text{m}$. The absolute accuracy for short distance movements is better than $\pm 0.1\text{mm}$, i.e., the $SAR_{tolerance}[\%]$ is better than 1.5% (rectangular).

7.9. PROBE POSITIONING

The probe positioning procedures affect the tolerance of the separation distance between the probe tip and the phantom surface as:

$$SAR_{tolerance} [\%] = 100 \times \frac{d_{ph}}{\delta/2}$$

where d_{ph} is the maximum deviation of the distance between the probe tip and the phantom surface. The optical surface detection has a precision of better than 0.2mm, resulting in an $SAR_{tolerance}[\%]$ of <2.9% (rectangular distribution). Since the mechanical detection provides better accuracy, 2.9% is a worst-case figure for DASY4 system.



7.10. PHANTOM UNCERTAINTY

The SAR measurement uncertainty due to SPEAG phantom shell production tolerances has been evaluated using

$$SAR_{tolerance} [\%] \cong 100 \times \frac{2d}{a}, \quad d \ll a$$

For a maximum deviation d of the inner and outer shell of the phantom from that specified in the CAD file of $\pm 0.2\text{mm}$, and a 10mm spacing a between source and tissue liquid, the calculated phantom uncertainty is $\pm 4.0\%$.



7.11. DASY4 UNCERTAINTY BUDGET

Error Description	Tolerance (±%)	Probability Distribution	Divisor	(C _i)		Standard Uncertainty (±%)		(v _i)
				(1g)	(10g)	(1g)	(10g)	
Measurement Equipment								
Probe Calibration	5.50	Normal	1	1	1	5.50	5.50	∞
Axial Isotropy	4.70	Rectangular	√3	0.7	0.7	1.90	1.90	∞
Hemispherical Isotropy	9.60	Rectangular	√3	0.7	0.7	3.88	3.88	∞
Boundary effects	1.00	Rectangular	√3	1	1	0.58	0.58	∞
Linearity	4.70	Rectangular	√3	1	1	2.71	2.71	∞
System Detection Limits	1.00	Rectangular	√3	1	1	0.58	0.58	∞
Readout Electronics	0.30	Normal	1	1	1	0.30	0.30	∞
Response Time	0.80	Rectangular	√3	1	1	0.46	0.46	∞
Integration Time	2.60	Rectangular	√3	1	1	1.50	1.50	∞
RF Ambient Noise	3.00	Rectangular	√3	1	1	1.73	1.73	∞
RF Ambient Reflections	3.00	Rectangular	√3	1	1	1.73	1.73	∞
Probe Positioner	0.40	Rectangular	√3	1	1	0.23	0.23	∞
Probe Positioning	2.90	Rectangular	√3	1	1	1.67	1.67	∞
Max. SAR Eval.	1.00	Rectangular	√3	1	1	0.58	0.58	∞
Test Sample Related								
Device Positioning	0.69	Normal	1	1	1	0.69	0.69	10
Device Holder	3.60	Normal	1	1	1	3.60	3.60	5
Power Drift	5.00	Rectangular	√3	1	1	2.89	2.89	∞
Phantom and Tissue parameters								
Phantom Uncertainty	4.00	Rectangular	√3	1	1	2.31	2.31	∞
Liquid Conductivity (target)	5.00	Rectangular	√3	0.64	0.43	1.85	1.24	∞
Liquid Conductivity (measurement)	2.10	Normal	1	0.64	0.43	1.34	0.90	∞
Liquid Permittivity (target)	5.00	Rectangular	√3	0.6	0.49	1.73	1.41	∞
Liquid Permittivity (measurement)	4.30	Normal	1	0.6	0.49	2.58	2.11	∞
Combined Standard Uncertainty						10.52	10.23	
Coverage Factor for 95%						Kp=2		
Expanded Uncertainty (K=2)						21.04	20.45	

TABLE 7.2

The table 7.2: Worst-Case uncertainty budget for DASY4 assessed according to IEEE 1528. The budget is valid for the frequency range 300MHz ~ 3GHz and represents a worst-case analysis. For specific tests and configurations, the uncertainty could be considerable smaller.



A D T

8. INFORMATION ON THE TESTING LABORATORIES

We, Bureau Veritas Consumer Products Services (H.K.) Ltd., Taoyuan Branch, were founded in 1988 to provide our best service in EMC, Radio, Telecom and Safety consultation. Our laboratories are accredited and approved by the following approval agencies according to ISO/IEC 17025.

USA	FCC, NVLAP
GERMANY	TUV Rheinland
JAPAN	VCCI
NORWAY	NEMKO
CANADA	INDUSTRY CANADA, CSA
R.O.C.	TAF, BSMI, NCC
NETHERLANDS	Telefication
SINGAPORE	GOST-ASIA (MOU)
RUSSIA	CERTIS (MOU)

Copies of accreditation certificates of our laboratories obtained from approval agencies can be downloaded from our web site:

www.adt.com.tw/index.5/phtml. If you have any comments, please feel free to contact us at the following:

Linko EMC/RF Lab:
Tel: 886-2-26052180
Fax: 886-2-26051924

Hsin Chu EMC/RF Lab:
Tel: 886-3-5935343
Fax: 886-3-5935342

Hwa Ya EMC/RF/Safety/Telecom Lab:
Tel: 886-3-3183232
Fax: 886-3-3185050

Web Site: www.adt.com.tw

The address and road map of all our labs can be found in our web site also.

---END---

APPENDIX A: TEST DATA

Liquid Level Photo

Tissue HSL2450MHz D=151mm



Tissue MSL2450MHz D=150mm



Test Laboratory: Bureau Veritas ADT

M01-Right Head-Cheek-11b-Ch6

DUT: Pocket PC Phone ; Type: RHOD500

Communication System: 802.11b ; Frequency: 2437 MHz ; Duty Cycle: 1:1

Medium: HSL2450 Medium parameters used: $f = 2437$ MHz; $\sigma = 1.78$ mho/m; $\epsilon_r = 40.1$; $\rho = 1000$ kg/m³

Phantom section: Right Section ; DUT test position : Cheek ; Modulation type: DBPSK

DASY4 Configuration:

- Probe: EX3DV3 - SN3504 ; ConvF(7.67, 7.67, 7.67) ; Calibrated: 2009/1/21
- Sensor-Surface: 3mm (Mechanical Surface Detection)
- Electronics: DAE3 Sn510 ; Calibrated: 2009/1/21
- Phantom: SAM 12; Type: SAM V4.0; Serial: TP 1202
- Measurement SW: DASY4, V4.7 Build 80; Postprocessing SW: SEMCAD, V1.8 Build 186

Touch position - Mid Channel 6/Area Scan (6x10x1): Measurement grid: dx=15mm, dy=15mm
Maximum value of SAR (measured) = 0.097 mW/g

Touch position - Mid Channel 6/Zoom Scan (7x7x7) (7x7x7)/Cube 0: Measurement grid:
dx=5mm, dy=5mm, dz=5mm
Reference Value = 3.78 V/m
Peak SAR (extrapolated) = 0.175 W/kg
SAR(1 g) = 0.093 mW/g; SAR(10 g) = 0.060 mW/g
Maximum value of SAR (measured) = 0.113 mW/g

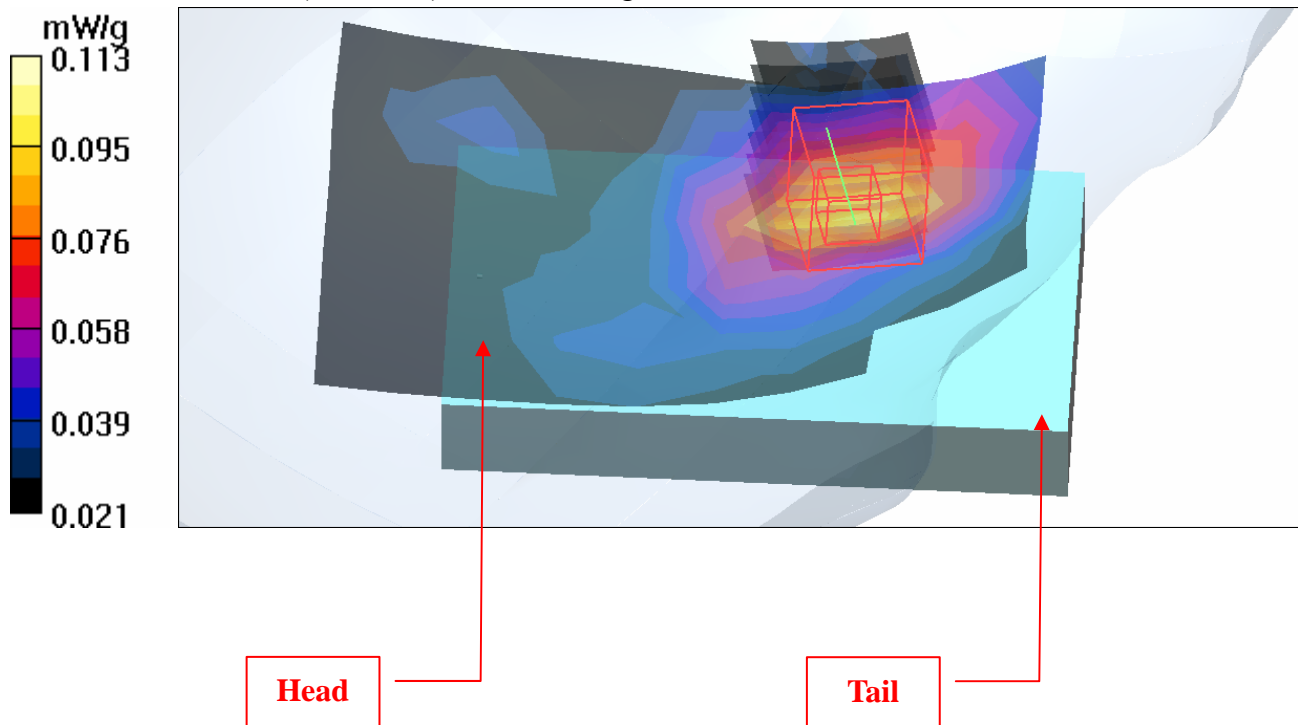

Test Laboratory: Bureau Veritas ADT

M02-Right Head-Tilt-11b-Ch6

DUT: Pocket PC Phone ; Type: RHOD500

Communication System: 802.11b ; Frequency: 2437 MHz; Duty Cycle: 1:1

Medium: HSL2450 Medium parameters used: $f = 2437$ MHz; $\sigma = 1.78$ mho/m; $\epsilon_r = 40.1$; $\rho = 1000$ kg/m³

Phantom section: Right Section ; DUT test position : Tilt ; Modulation type: DBPSK

DASY4 Configuration:

- Probe: EX3DV3 - SN3504 ; ConvF(7.67, 7.67, 7.67) ; Calibrated: 2009/1/21
- Sensor-Surface: 3mm (Mechanical Surface Detection)
- Electronics: DAE3 Sn510 ; Calibrated: 2009/1/21
- Phantom: SAM 12; Type: SAM V4.0; Serial: TP 1202
- Measurement SW: DASY4, V4.7 Build 80; Postprocessing SW: SEMCAD, V1.8 Build 186

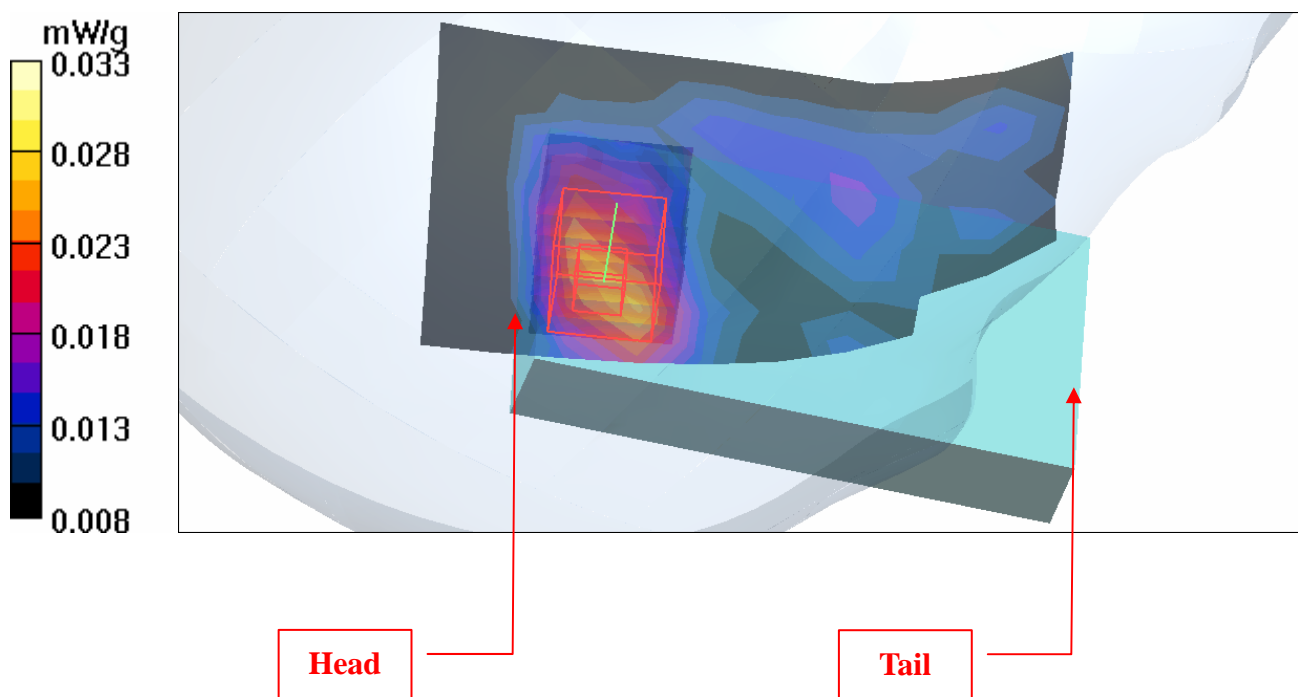
Tilt position - Mid Channel 6/Area Scan (6x10x1): Measurement grid: dx=15mm, dy=15mm
Maximum value of SAR (measured) = 0.027 mW/g**Tilt position - Mid Channel 6/Zoom Scan (7x7x7) (7x7x7)/Cube 0:** Measurement grid:
dx=5mm, dy=5mm, dz=5mm
Reference Value = 3.80 V/m
Peak SAR (extrapolated) = 0.046 W/kg
SAR(1 g) = 0.026 mW/g; SAR(10 g) = 0.017 mW/g
Maximum value of SAR (measured) = 0.033 mW/g

Test Laboratory: Bureau Veritas ADT

M03-Left Head-Cheek-11b-Ch6

DUT: Pocket PC Phone ; Type: RHOD500

Communication System: 802.11b ; Frequency: 2437 MHz ; Duty Cycle: 1:1

Medium: HSL2450 Medium parameters used: $f = 2437$ MHz; $\sigma = 1.78$ mho/m; $\epsilon_r = 40.1$; $\rho = 1000$ kg/m³

Phantom section: Left Section ; DUT test position : Cheek ; Modulation type: DBPSK

DASY4 Configuration:

- Probe: EX3DV3 - SN3504 ; ConvF(7.67, 7.67, 7.67) ; Calibrated: 2009/1/21
- Sensor-Surface: 3mm (Mechanical Surface Detection)
- Electronics: DAE3 Sn510 ; Calibrated: 2009/1/21
- Phantom: SAM 12; Type: SAM V4.0; Serial: TP 1202
- Measurement SW: DASY4, V4.7 Build 80; Postprocessing SW: SEMCAD, V1.8 Build 186

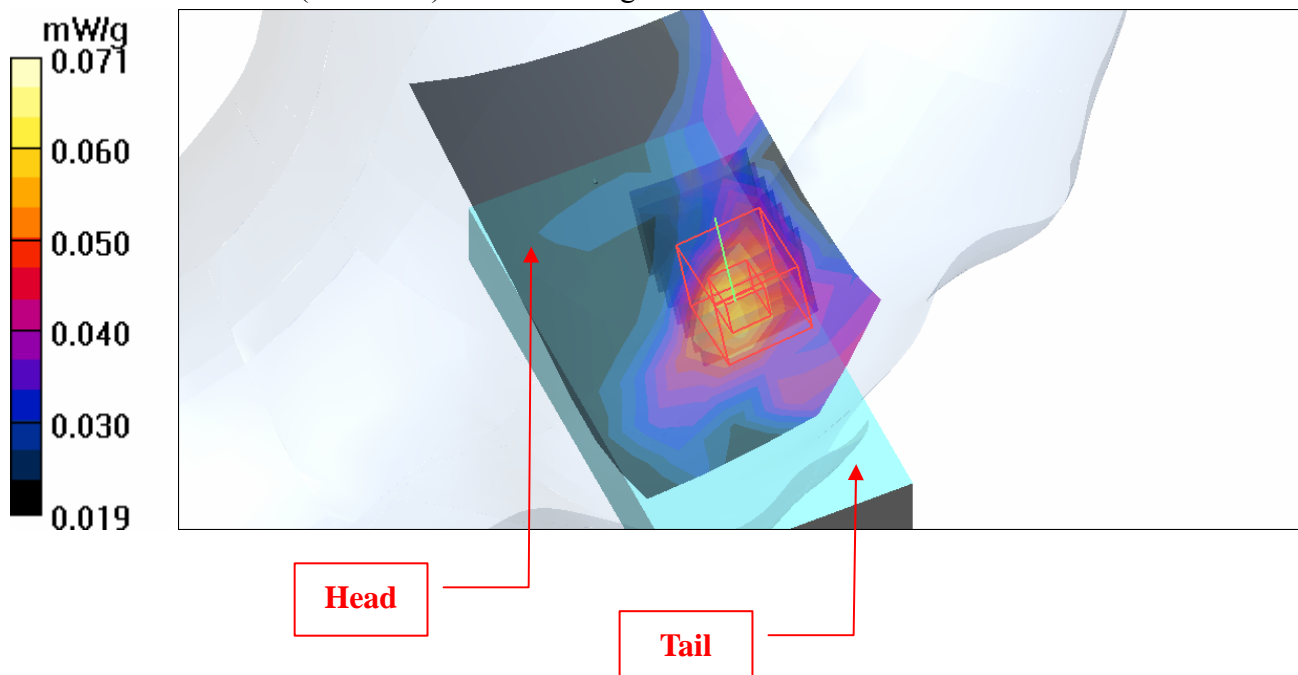
Touch position - Mid Channel 6/Area Scan (6x10x1): Measurement grid: dx=15mm, dy=15mm
Maximum value of SAR (measured) = 0.061 mW/g**Touch position - Mid Channel 6/Zoom Scan (7x7x7) (7x7x7)/Cube 0:** Measurement grid:
dx=5mm, dy=5mm, dz=5mm
Reference Value = 4.36 V/m
Peak SAR (extrapolated) = 0.101 W/kg
SAR(1 g) = 0.055 mW/g; SAR(10 g) = 0.041 mW/g
Maximum value of SAR (measured) = 0.071 mW/g

Test Laboratory: Bureau Veritas ADT

M04-Left Head-Tilt-11b-Ch6

DUT: Pocket PC Phone ; Type: RHOD500

Communication System: 802.11b ; Frequency: 2437 MHz; Duty Cycle: 1:1

Medium: HSL2450 Medium parameters used: $f = 2437$ MHz; $\sigma = 1.78$ mho/m; $\epsilon_r = 40.1$; $\rho = 1000$ kg/m³

Phantom section: Left Section ; DUT test position : Tilt ; Modulation type: DBPSK

DASY4 Configuration:

- Probe: EX3DV3 - SN3504 ; ConvF(7.67, 7.67, 7.67) ; Calibrated: 2009/1/21
- Sensor-Surface: 3mm (Mechanical Surface Detection)
- Electronics: DAE3 Sn510 ; Calibrated: 2009/1/21
- Phantom: SAM 12; Type: SAM V4.0; Serial: TP 1202
- Measurement SW: DASY4, V4.7 Build 80; Postprocessing SW: SEMCAD, V1.8 Build 186

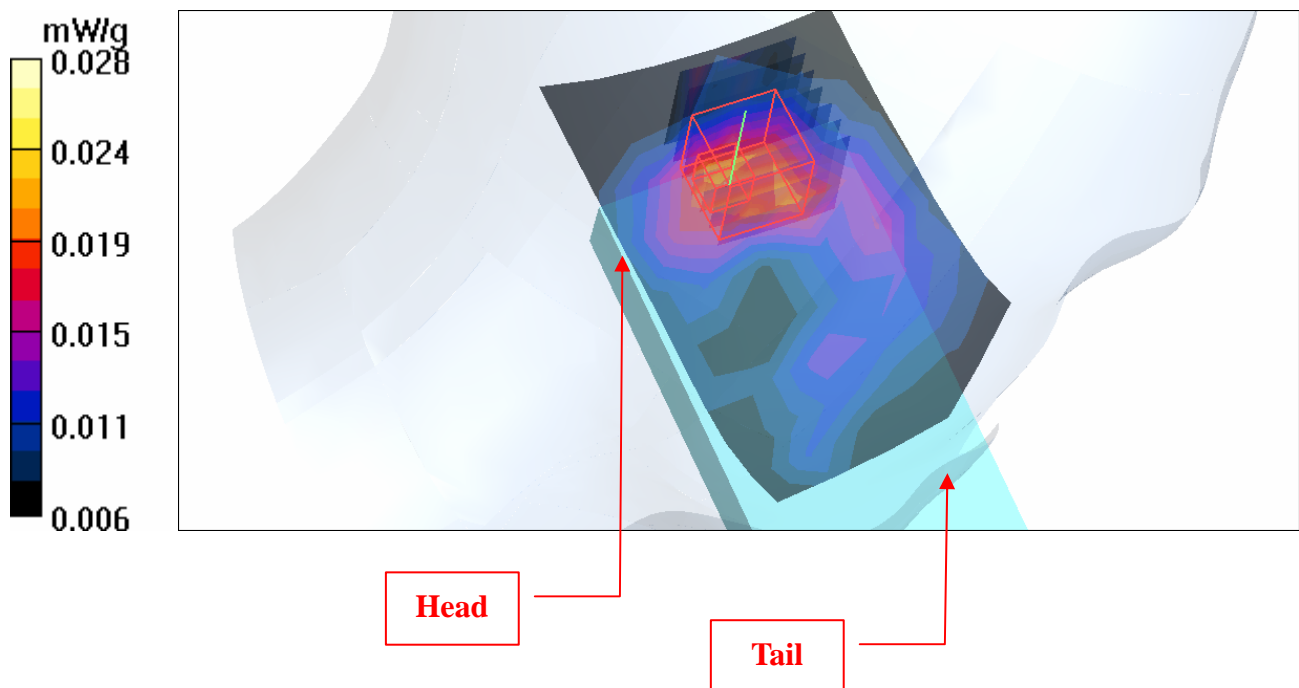
Tilt position - Mid Channel 6/Area Scan (6x10x1): Measurement grid: dx=15mm, dy=15mm
Maximum value of SAR (measured) = 0.020 mW/g**Tilt position - Mid Channel 6/Zoom Scan (7x7x7) (7x7x7)/Cube 0:** Measurement grid:
dx=5mm, dy=5mm, dz=5mm
Reference Value = 3.55 V/m
Peak SAR (extrapolated) = 0.038 W/kg
SAR(1 g) = 0.023 mW/g; SAR(10 g) = 0.015 mW/g
Maximum value of SAR (measured) = 0.028 mW/g

Test Laboratory: Bureau Veritas ADT

M05-Body-11b-Ch6 Slider-off LCD Down**DUT: Pocket PC Phone ; Type: RHOD500**

Communication System: 802.11b ; Frequency: 2437 MHz ; Duty Cycle: 1:1

Medium: MSL2450 Medium parameters used: $f = 2437$ MHz; $\sigma = 1.93$ mho/m; $\epsilon_r = 54.7$; $\rho = 1000$ kg/m³

Phantom section: Flat Section ; DUT test position : Body ; Modulation Type: DBPSK

Separation Distance : 15 mm (The bottom side of the EUT to the Phantom)

DASY4 Configuration:

- Probe: EX3DV3 - SN3504 ; ConvF(7.53, 7.53, 7.53) ; Calibrated: 2009/1/21

- Sensor-Surface: 3mm (Mechanical Surface Detection)

- Electronics: DAE3 Sn510 ; Calibrated: 2009/1/21

- Phantom: SAM 12 ; Type: SAM V4.0; Serial: TP 1202

- Measurement SW: DASY4, V4.7 Build 80 ; Postprocessing SW: SEMCAD, V1.8 Build 186

Mid Channel 6/Area Scan (6x10x1): Measurement grid: dx=15mm, dy=15mm

Maximum value of SAR (measured) = 0.198 mW/g

Mid Channel 6/Zoom Scan (7x7x7) (7x7x7)/Cube 0: Measurement grid: dx=5mm, dy=5mm, dz=5mm

Reference Value = 6.52 V/m

Peak SAR (extrapolated) = 0.439 W/kg

SAR(1 g) = 0.193 mW/g; SAR(10 g) = 0.106 mW/g

Maximum value of SAR (measured) = 0.200 mW/g

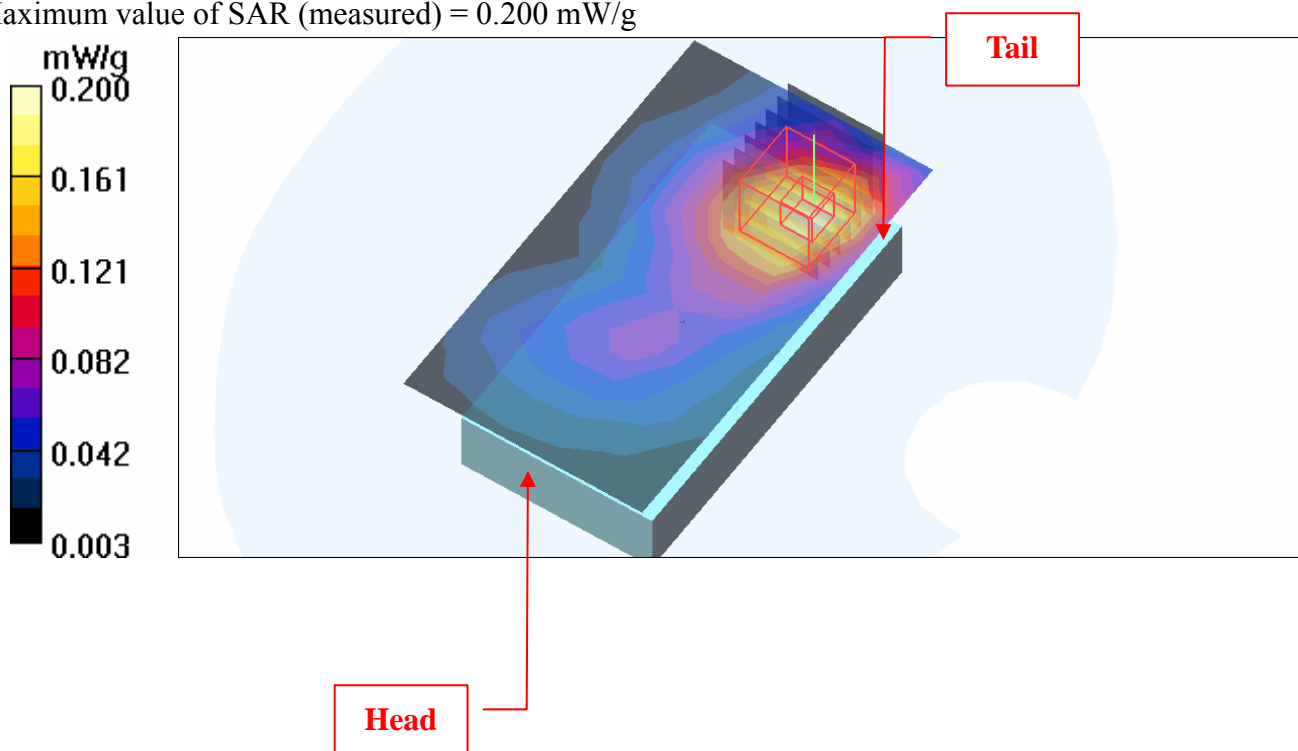

Test Laboratory: Bureau Veritas ADT

M06-Body-11b-Ch6 Slider-off LCD UP

DUT: Pocket PC Phone ; Type: RHOD500

Communication System: 802.11b ; Frequency: 2437 MHz ; Duty Cycle: 1:1

Medium: MSL2450 Medium parameters used: $f = 2437$ MHz; $\sigma = 1.93$ mho/m; $\epsilon_r = 54.7$; $\rho = 1000$ kg/m³

Phantom section: Flat Section ; DUT test position : Body ; Modulation Type: DBPSK

Separation Distance : 15 mm (The front side of the EUT to the Phantom)

DASY4 Configuration:

- Probe: EX3DV3 - SN3504 ; ConvF(7.53, 7.53, 7.53) ; Calibrated: 2009/1/21
- Sensor-Surface: 3mm (Mechanical Surface Detection)
- Electronics: DAE3 Sn510 ; Calibrated: 2009/1/21
- Phantom: SAM 12 ; Type: SAM V4.0; Serial: TP 1202
- Measurement SW: DASY4, V4.7 Build 80 ; Postprocessing SW: SEMCAD, V1.8 Build 186

Mid Channel 6/Area Scan (6x12x1): Measurement grid: dx=15mm, dy=15mm

Maximum value of SAR (measured) = 0.023 mW/g

Mid Channel 6/Zoom Scan (7x7x7) (7x7x7)/Cube 0: Measurement grid: dx=5mm, dy=5mm, dz=5mm

Reference Value = 0.755 V/m

Peak SAR (extrapolated) = 0.063 W/kg

SAR(1 g) = 0.021 mW/g; SAR(10 g) = 0.010 mW/g

Maximum value of SAR (measured) = 0.024 mW/g

Mid Channel 6/Zoom Scan (7x7x7) (7x7x7)/Cube 1: Measurement grid: dx=5mm, dy=5mm, dz=5mm

Reference Value = 0.755 V/m

Peak SAR (extrapolated) = 0.065 W/kg

SAR(1 g) = 0.022 mW/g; SAR(10 g) = 0.012 mW/g

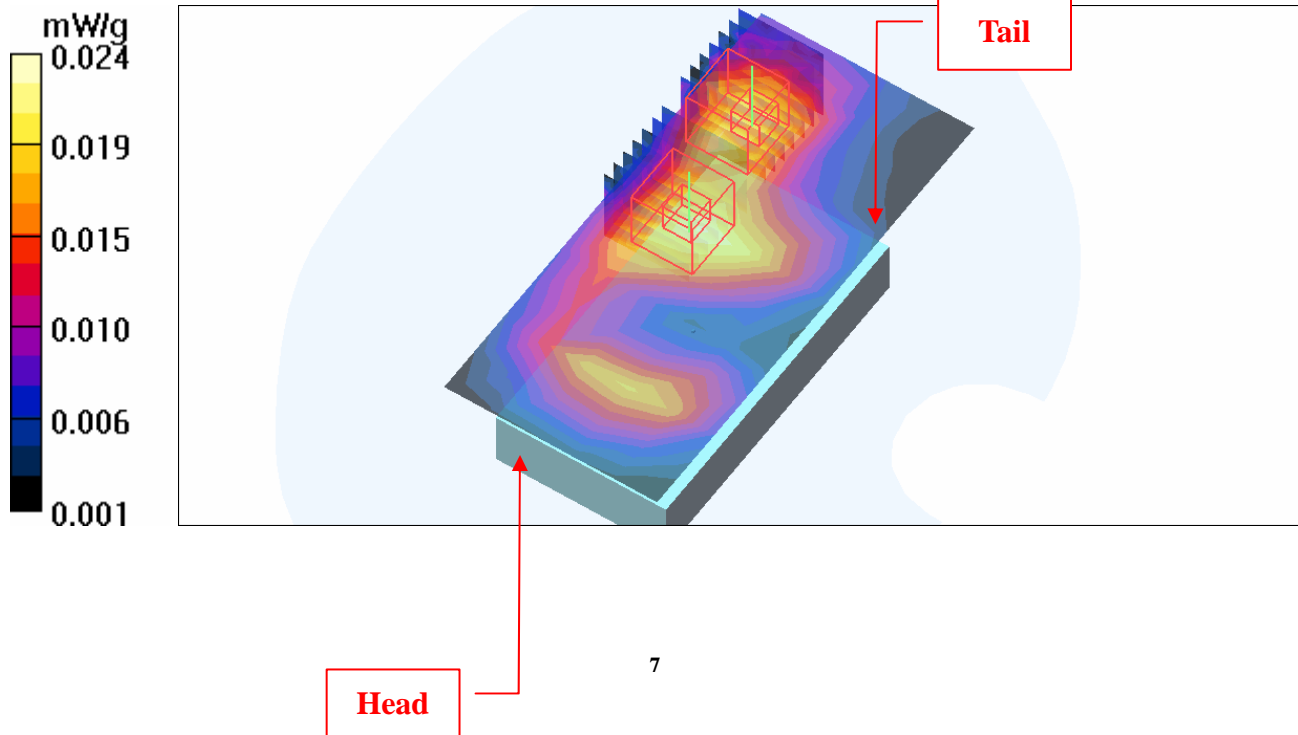

Test Laboratory: Bureau Veritas ADT

M07-Body-11b-Ch6 Slider-on LCD Down

DUT: Pocket PC Phone ; Type: RHOD500

Communication System: 802.11b ; Frequency: 2437 MHz ; Duty Cycle: 1:1
 Medium: MSL2450 Medium parameters used: $f = 2437 \text{ MHz}$; $\sigma = 1.93 \text{ mho/m}$; $\epsilon_r = 54.7$; $\rho = 1000 \text{ kg/m}^3$
 Phantom section: Flat Section ; DUT test position : Body ; Modulation Type: DBPSK
 Separation Distance : 15 mm (The bottom side of the EUT to the Phantom)

DASY4 Configuration:

- Probe: EX3DV3 - SN3504 ; ConvF(7.53, 7.53, 7.53) ; Calibrated: 2009/1/21
- Sensor-Surface: 3mm (Mechanical Surface Detection)
- Electronics: DAE3 Sn510 ; Calibrated: 2009/1/21
- Phantom: SAM 12 ; Type: SAM V4.0; Serial: TP 1202
- Measurement SW: DASY4, V4.7 Build 80 ; Postprocessing SW: SEMCAD, V1.8 Build 186

Mid Channel 6/Area Scan (9x10x1): Measurement grid: $dx=15\text{mm}$, $dy=15\text{mm}$
 Maximum value of SAR (measured) = 0.197 mW/g

Mid Channel 6/Zoom Scan (7x7x7) (7x7x7)/Cube 0: Measurement grid: $dx=5\text{mm}$, $dy=5\text{mm}$, $dz=5\text{mm}$

Reference Value = 5.97 V/m

Peak SAR (extrapolated) = 0.344 W/kg

SAR(1 g) = 0.198 mW/g; SAR(10 g) = 0.124 mW/g

Maximum value of SAR (measured) = 0.235 mW/g

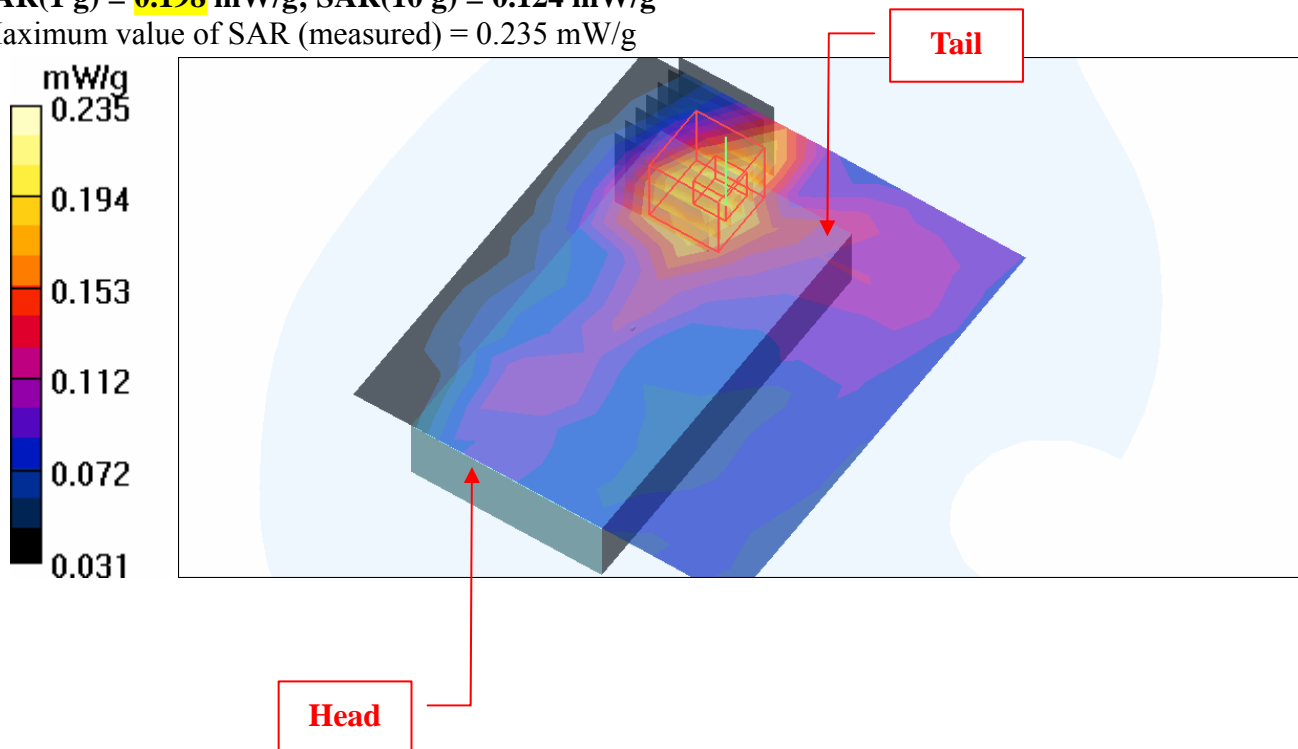

Test Laboratory: Bureau Veritas ADT

M08-Body-11b-Ch6 Slider-on LCD UP

DUT: Pocket PC Phone ; Type: RHOD500

Communication System: 802.11b ; Frequency: 2437 MHz ; Duty Cycle: 1:1

Medium: MSL2450 Medium parameters used: $f = 2437$ MHz; $\sigma = 1.93$ mho/m; $\epsilon_r = 54.7$; $\rho = 1000$ kg/m³

Phantom section: Flat Section ; DUT test position : Body ; Modulation Type: DBPSK

Separation Distance : 15 mm (The front side of the EUT to the Phantom)

DASY4 Configuration:

- Probe: EX3DV3 - SN3504 ; ConvF(7.53, 7.53, 7.53) ; Calibrated: 2009/1/21
- Sensor-Surface: 3mm (Mechanical Surface Detection)
- Electronics: DAE3 Sn510 ; Calibrated: 2009/1/21
- Phantom: SAM 12 ; Type: SAM V4.0; Serial: TP 1202
- Measurement SW: DASY4, V4.7 Build 80 ; Postprocessing SW: SEMCAD, V1.8 Build 186

Mid Channel 6/Area Scan (9x10x1): Measurement grid: dx=15mm, dy=15mm

Maximum value of SAR (measured) = 0.023 mW/g

Mid Channel 6/Zoom Scan (7x7x7) (7x7x7)/Cube 0: Measurement grid: dx=5mm, dy=5mm, dz=5mm

Reference Value = 0.623 V/m

Peak SAR (extrapolated) = 0.095 W/kg

SAR(1 g) = 0.026 mW/g; SAR(10 g) = 0.0012 mW/g

Maximum value of SAR (measured) = 0.028 mW/g

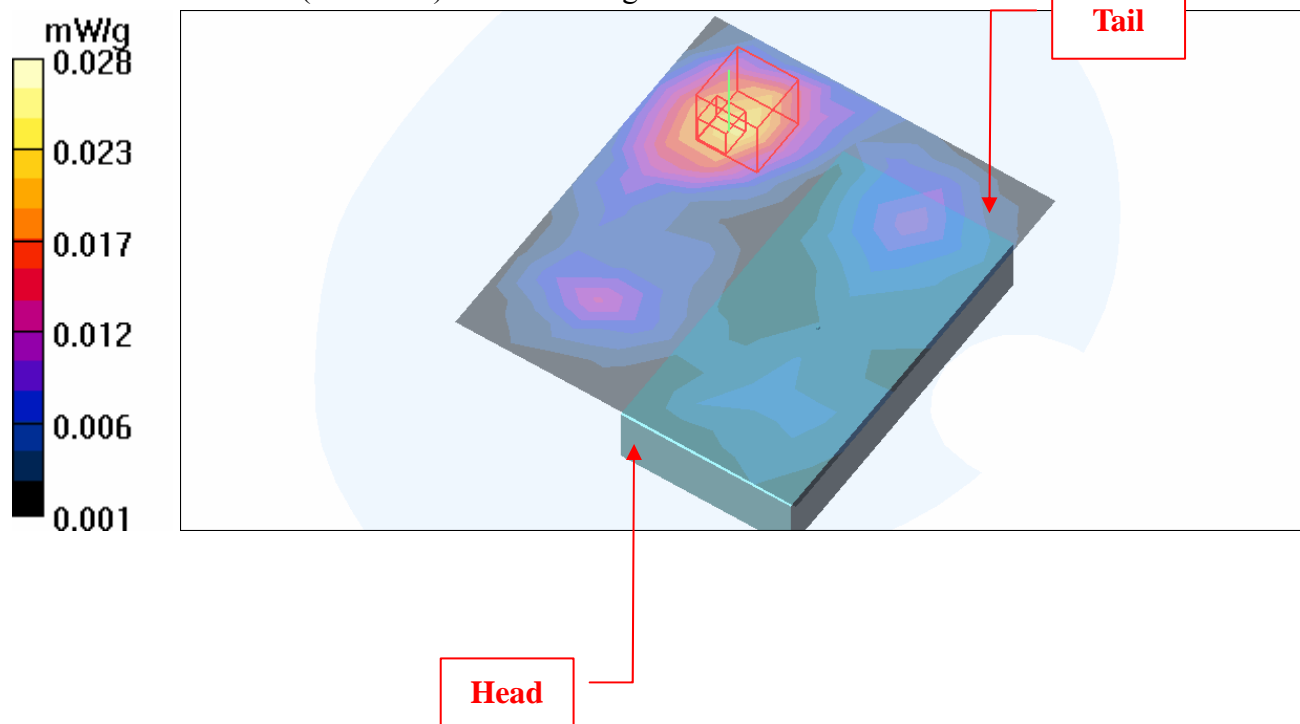

Test Laboratory: Bureau Veritas ADT

M09-Right Head-Cheek-11g-Ch6

DUT: Pocket PC Phone ; Type: RHOD500

Communication System: 802.11g ; Frequency: 2437 MHz ; Duty Cycle: 1:1

Medium: HSL2450 Medium parameters used: $f = 2437$ MHz; $\sigma = 1.78$ mho/m; $\epsilon_r = 40.1$; $\rho = 1000$ kg/m³

Phantom section: Right Section ; DUT test position : Cheek ; Modulation type: BPSK

DASY4 Configuration:

- Probe: EX3DV3 - SN3504 ; ConvF(7.67, 7.67, 7.67) ; Calibrated: 2009/1/21
- Sensor-Surface: 3mm (Mechanical Surface Detection)
- Electronics: DAE3 Sn510 ; Calibrated: 2009/1/21
- Phantom: SAM 12; Type: SAM V4.0; Serial: TP 1202
- Measurement SW: DASY4, V4.7 Build 80; Postprocessing SW: SEMCAD, V1.8 Build 186

Touch position - Mid Channel 6/Area Scan (6x10x1): Measurement grid: dx=15mm, dy=15mm
Maximum value of SAR (measured) = 0.083 mW/g

Touch position - Mid Channel 6/Zoom Scan (7x7x7) (7x7x7)/Cube 0: Measurement grid:
dx=5mm, dy=5mm, dz=5mm
Reference Value = 5.82 V/m
Peak SAR (extrapolated) = 0.157 W/kg
SAR(1 g) = 0.079 mW/g; SAR(10 g) = 0.050 mW/g
Maximum value of SAR (measured) = 0.100 mW/g

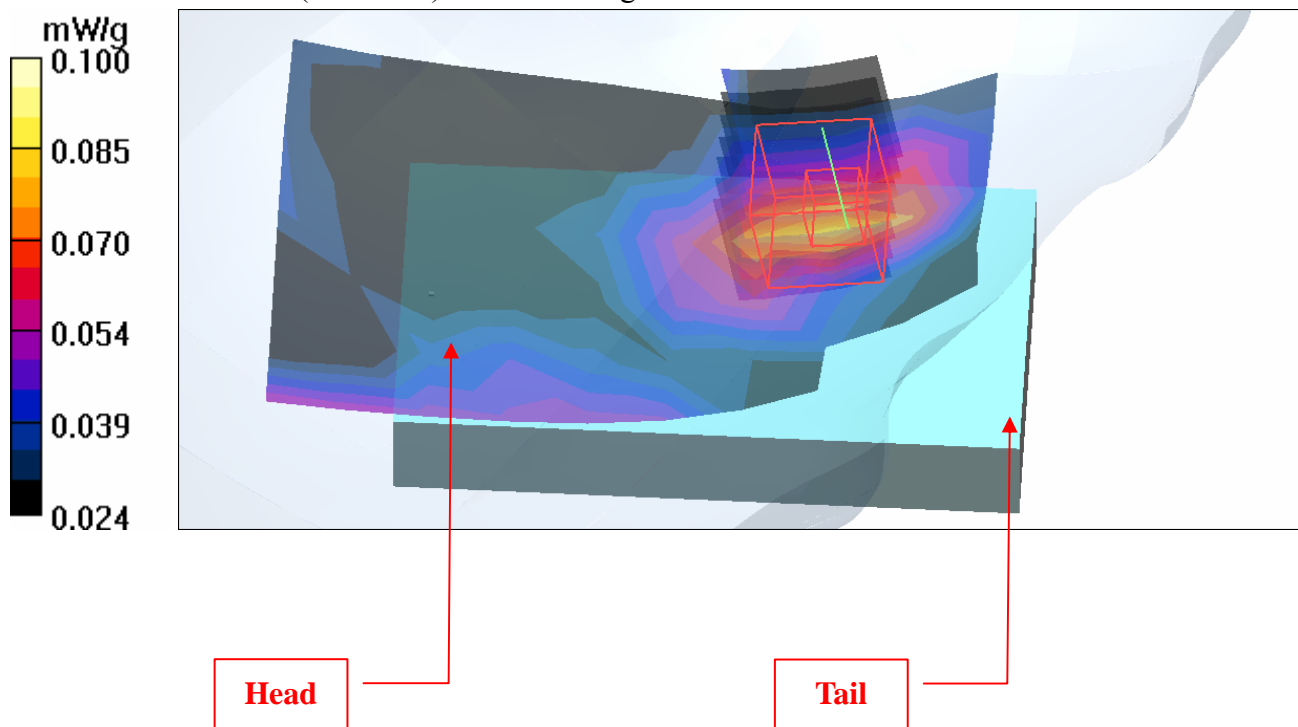

Test Laboratory: Bureau Veritas ADT

M10-Right Head-Tilt-11g-Ch6

DUT: Pocket PC Phone ; Type: RHOD500

Communication System: 802.11g ; Frequency: 2437 MHz; Duty Cycle: 1:1

Medium: HSL2450 Medium parameters used: $f = 2437$ MHz; $\sigma = 1.78$ mho/m; $\epsilon_r = 40.1$; $\rho = 1000$ kg/m³

Phantom section: Right Section ; DUT test position : Tilt ; Modulation type: BPSK

DASY4 Configuration:

- Probe: EX3DV3 - SN3504 ; ConvF(7.67, 7.67, 7.67) ; Calibrated: 2009/1/21
- Sensor-Surface: 3mm (Mechanical Surface Detection)
- Electronics: DAE3 Sn510 ; Calibrated: 2009/1/21
- Phantom: SAM 12; Type: SAM V4.0; Serial: TP 1202
- Measurement SW: DASY4, V4.7 Build 80; Postprocessing SW: SEMCAD, V1.8 Build 186

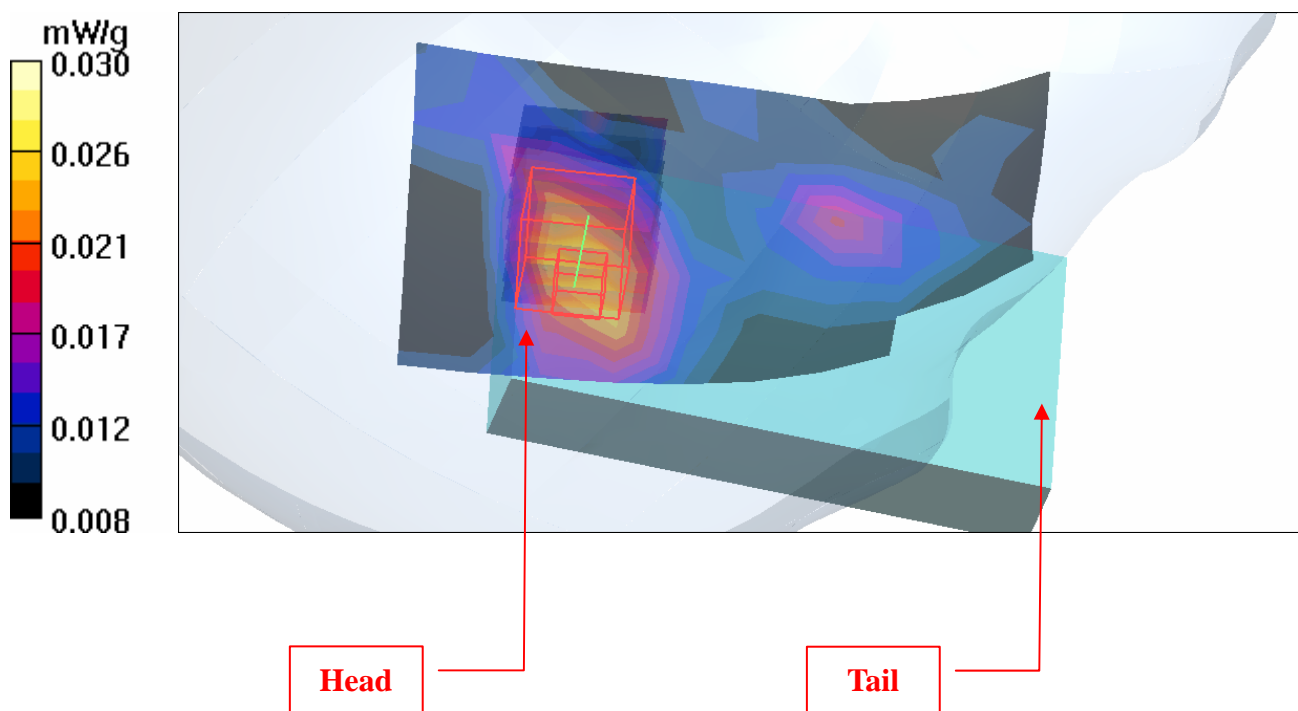
Tilt position - Mid Channel 6/Area Scan (6x10x1): Measurement grid: dx=15mm, dy=15mm
Maximum value of SAR (measured) = 0.025 mW/g**Tilt position - Mid Channel 6/Zoom Scan (7x7x7) (7x7x7)/Cube 0:** Measurement grid:
dx=5mm, dy=5mm, dz=5mm
Reference Value = 3.93 V/m
Peak SAR (extrapolated) = 0.046 W/kg
SAR(1 g) = 0.024 mW/g; SAR(10 g) = 0.017 mW/g
Maximum value of SAR (measured) = 0.030 mW/g

Test Laboratory: Bureau Veritas ADT

M11-Left Head-Cheek-11g-Ch6

DUT: Pocket PC Phone ; Type: RHOD500

Communication System: 802.11g ; Frequency: 2437 MHz ; Duty Cycle: 1:1

Medium: HSL2450 Medium parameters used: $f = 2437$ MHz; $\sigma = 1.78$ mho/m; $\epsilon_r = 40.1$; $\rho = 1000$ kg/m³

Phantom section: Left Section ; DUT test position : Cheek ; Modulation type: BPSK

DASY4 Configuration:

- Probe: EX3DV3 - SN3504 ; ConvF(7.67, 7.67, 7.67) ; Calibrated: 2009/1/21
- Sensor-Surface: 3mm (Mechanical Surface Detection)
- Electronics: DAE3 Sn510 ; Calibrated: 2009/1/21
- Phantom: SAM 12; Type: SAM V4.0; Serial: TP 1202
- Measurement SW: DASY4, V4.7 Build 80; Postprocessing SW: SEMCAD, V1.8 Build 186

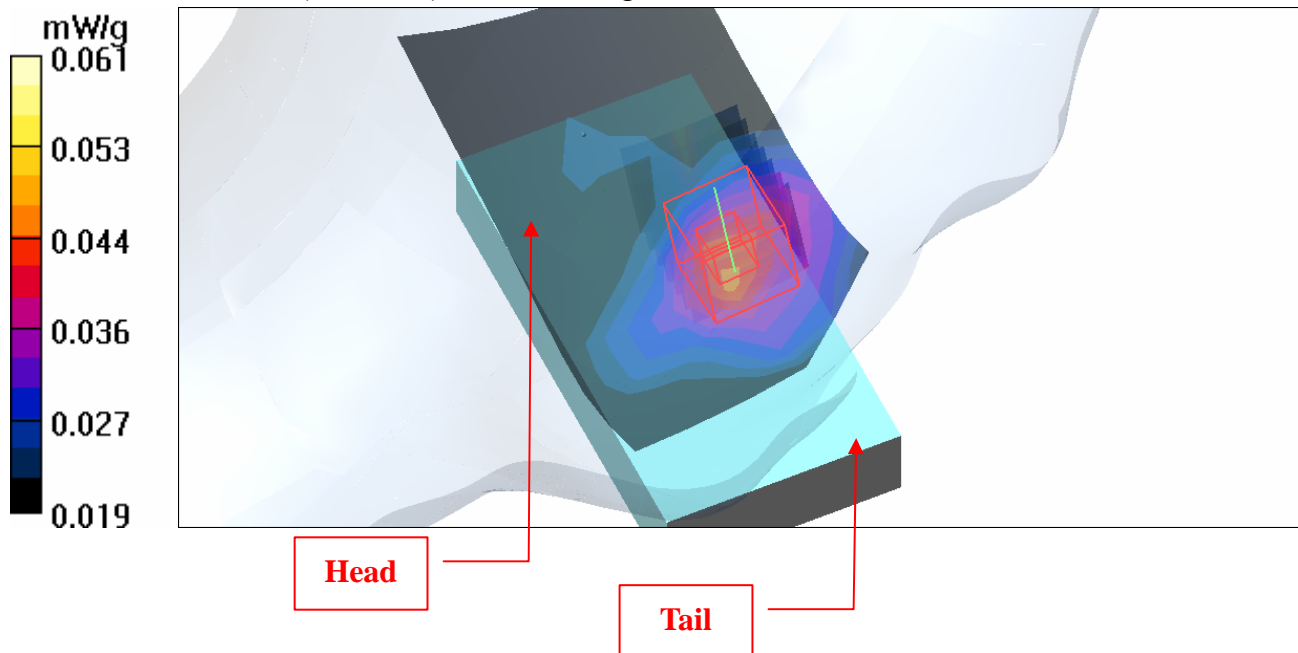
Touch position - Mid Channel 6/Area Scan (6x10x1): Measurement grid: dx=15mm, dy=15mm
Maximum value of SAR (measured) = 0.046 mW/g**Touch position - Mid Channel 6/Zoom Scan (7x7x7) (7x7x7)/Cube 0:** Measurement grid:
dx=5mm, dy=5mm, dz=5mm
Reference Value = 4.55 V/m
Peak SAR (extrapolated) = 0.075 W/kg
SAR(1 g) = 0.049 mW/g; SAR(10 g) = 0.034 mW/g
Maximum value of SAR (measured) = 0.061 mW/g

Test Laboratory: Bureau Veritas ADT

M12-Left Head-Tilt-11g-Ch6

DUT: Pocket PC Phone ; Type: RHOD500

Communication System: 802.11g ; Frequency: 2437 MHz; Duty Cycle: 1:1

Medium: HSL2450 Medium parameters used: $f = 2437$ MHz; $\sigma = 1.78$ mho/m; $\epsilon_r = 40.1$; $\rho = 1000$ kg/m³

Phantom section: Left Section ; DUT test position : Tilt ; Modulation type: BPSK

DASY4 Configuration:

- Probe: EX3DV3 - SN3504 ; ConvF(7.67, 7.67, 7.67) ; Calibrated: 2009/1/21
- Sensor-Surface: 3mm (Mechanical Surface Detection)
- Electronics: DAE3 Sn510 ; Calibrated: 2009/1/21
- Phantom: SAM 12; Type: SAM V4.0; Serial: TP 1202
- Measurement SW: DASY4, V4.7 Build 80; Postprocessing SW: SEMCAD, V1.8 Build 186

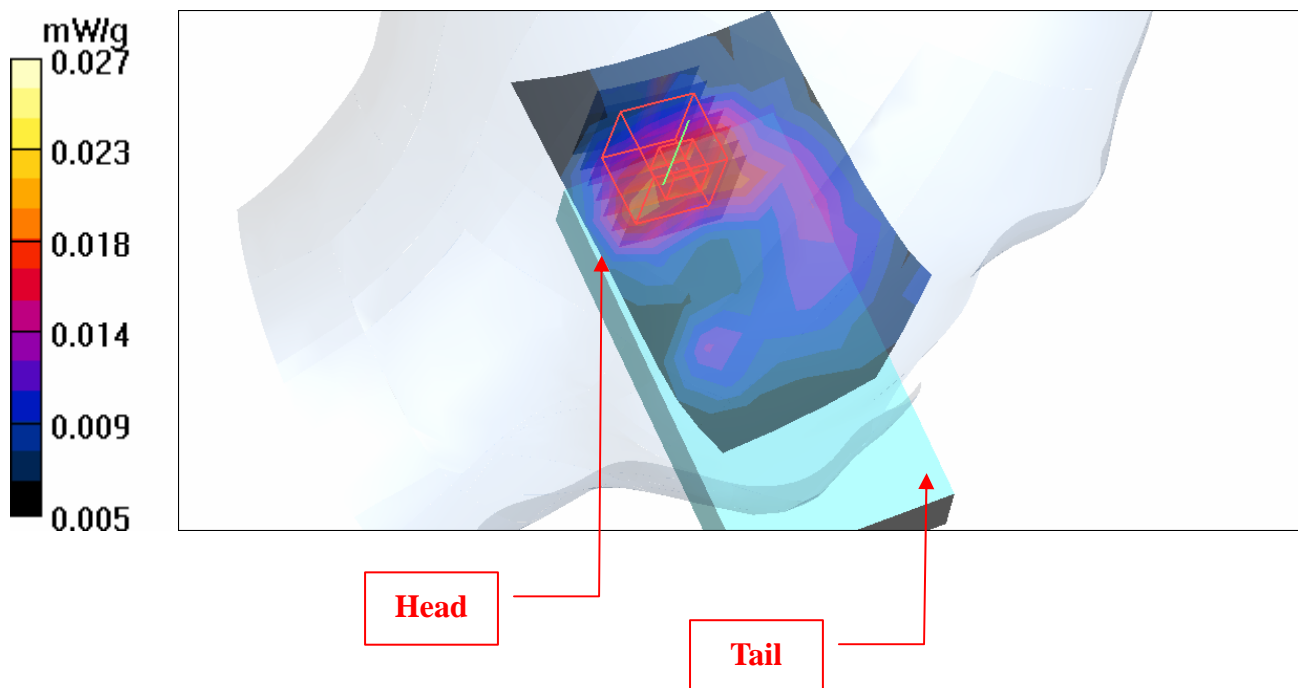
Tilt position - Mid Channel 6/Area Scan (6x10x1): Measurement grid: dx=15mm, dy=15mm
Maximum value of SAR (measured) = 0.020 mW/g**Tilt position - Mid Channel 6/Zoom Scan (7x7x7) (7x7x7)/Cube 0:** Measurement grid:
dx=5mm, dy=5mm, dz=5mm
Reference Value = 3.41 V/m
Peak SAR (extrapolated) = 0.039 W/kg
SAR(1 g) = 0.020 mW/g; SAR(10 g) = 0.013 mW/g
Maximum value of SAR (measured) = 0.027 mW/g

Test Laboratory: Bureau Veritas ADT

M13-Body-11g-Ch6 Slider-off LCD Down

DUT: Pocket PC Phone ; Type: RHOD500

Communication System: 802.11g ; Frequency: 2437 MHz ; Duty Cycle: 1:1

Medium: MSL2450 Medium parameters used: $f = 2437$ MHz; $\sigma = 1.93$ mho/m; $\epsilon_r = 54.7$; $\rho = 1000$ kg/m³

Phantom section: Flat Section ; DUT test position : Body ; Modulation Type: BPSK

Separation Distance : 15 mm (The bottom side of the EUT to the Phantom)

DASY4 Configuration:

- Probe: EX3DV3 - SN3504 ; ConvF(7.53, 7.53, 7.53) ; Calibrated: 2009/1/21

- Sensor-Surface: 3mm (Mechanical Surface Detection)

- Electronics: DAE3 Sn510 ; Calibrated: 2009/1/21

- Phantom: SAM 12 ; Type: SAM V4.0; Serial: TP 1202

- Measurement SW: DASY4, V4.7 Build 80 ; Postprocessing SW: SEMCAD, V1.8 Build 186

Mid Channel 6/Area Scan (6x10x1): Measurement grid: dx=15mm, dy=15mm

Maximum value of SAR (measured) = 0.150 mW/g

Mid Channel 6/Zoom Scan (7x7x7) (7x7x7)/Cube 0: Measurement grid: dx=5mm, dy=5mm, dz=5mm

Reference Value = 6.43 V/m

Peak SAR (extrapolated) = 0.187 W/kg

SAR(1 g) = 0.169 mW/g; SAR(10 g) = 0.153 mW/g

Maximum value of SAR (measured) = 0.178 mW/g

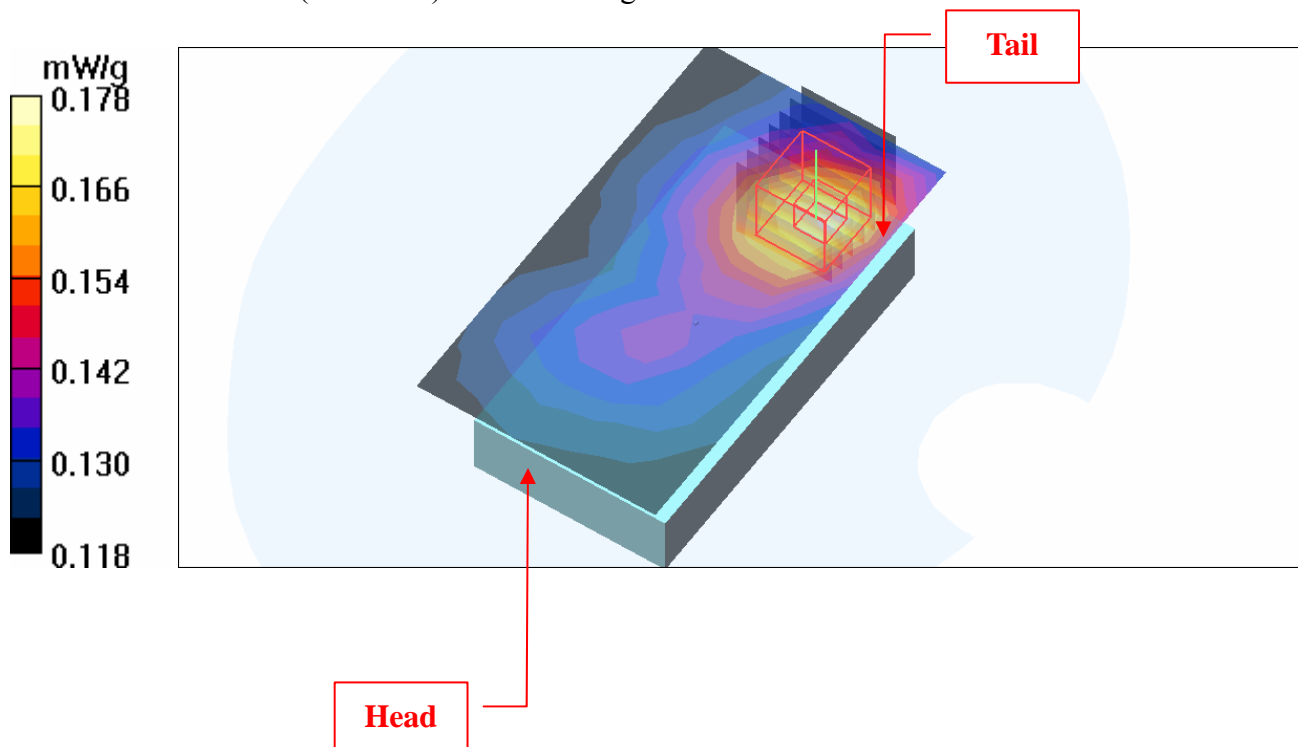

Test Laboratory: Bureau Veritas ADT

M14-Body-11g-Ch6 Slider-off LCD UP**DUT: Pocket PC Phone ; Type: RHOD500**

Communication System: 802.11g ; Frequency: 2437 MHz ; Duty Cycle: 1:1

Medium: MSL2450 Medium parameters used: $f = 2437$ MHz; $\sigma = 1.93$ mho/m; $\epsilon_r = 54.7$; $\rho = 1000$ kg/m³

Phantom section: Flat Section ; DUT test position : Body ; Modulation Type: BPSK

Separation Distance : 15 mm (The front side of the EUT to the Phantom)

DASY4 Configuration:

- Probe: EX3DV3 - SN3504 ; ConvF(7.53, 7.53, 7.53) ; Calibrated: 2009/1/21

- Sensor-Surface: 3mm (Mechanical Surface Detection)

- Electronics: DAE3 Sn510 ; Calibrated: 2009/1/21

- Phantom: SAM 12 ; Type: SAM V4.0; Serial: TP 1202

- Measurement SW: DASY4, V4.7 Build 80 ; Postprocessing SW: SEMCAD, V1.8 Build 186

Mid Channel 6/Area Scan (6x12x1): Measurement grid: dx=15mm, dy=15mm

Maximum value of SAR (measured) = 0.012 mW/g

Mid Channel 6/Zoom Scan (7x7x7) (7x7x7)/Cube 0: Measurement grid: dx=5mm, dy=5mm, dz=5mm

Reference Value = 0.842 V/m

Peak SAR (extrapolated) = 0.054 W/kg

SAR(1 g) = **0.013** mW/g; SAR(10 g) = 0.0062 mW/g**Mid Channel 6/Zoom Scan (7x7x7) (7x7x7)/Cube 1:** Measurement grid: dx=5mm, dy=5mm, dz=5mm

Reference Value = 0.842 V/m

Peak SAR (extrapolated) = 0.050 W/kg

SAR(1 g) = **0.012** mW/g; SAR(10 g) = **0.00519** mW/g

Maximum value of SAR (measured) = 0.012 mW/g

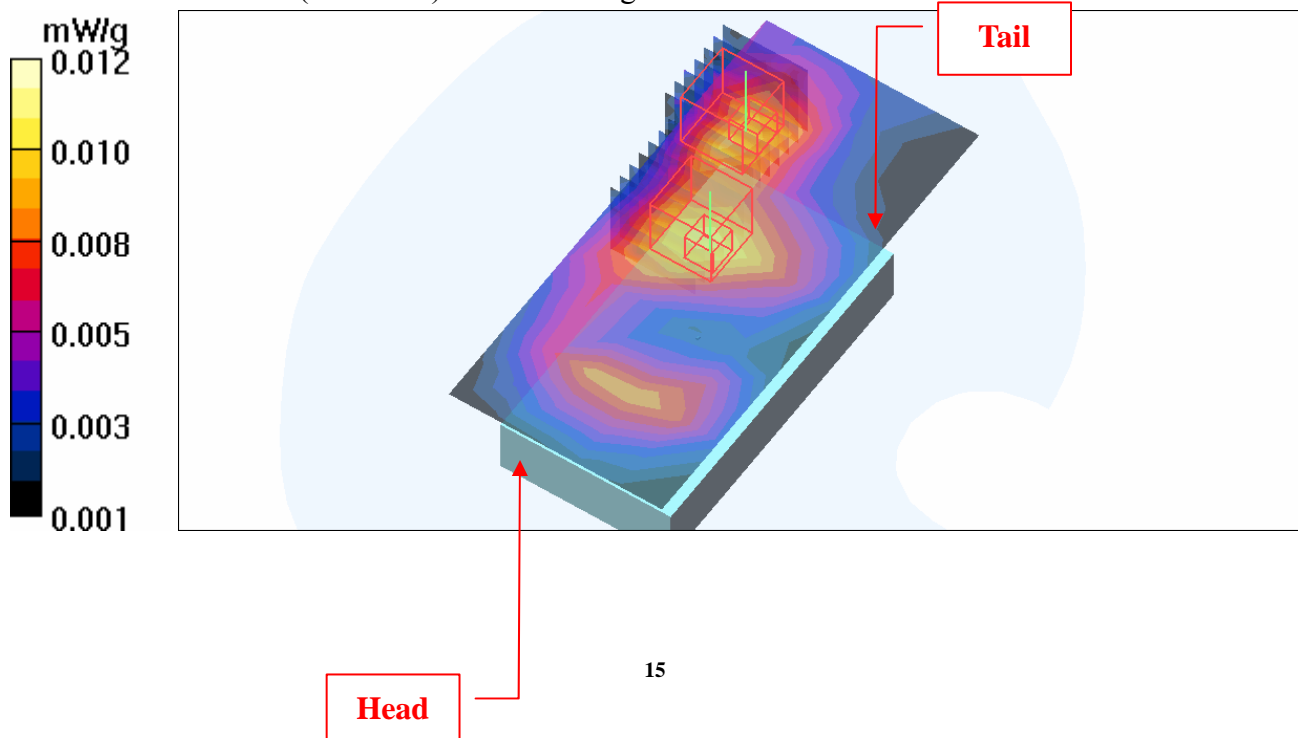

Test Laboratory: Bureau Veritas ADT

M15-Body-11g-Ch6 Slider-on LCD Down

DUT: Pocket PC Phone ; Type: RHOD500

Communication System: 802.11g ; Frequency: 2437 MHz ; Duty Cycle: 1:1
 Medium: MSL2450 Medium parameters used: $f = 2437$ MHz; $\sigma = 1.93$ mho/m; $\epsilon_r = 54.7$; $\rho = 1000$ kg/m³
 Phantom section: Flat Section ; DUT test position : Body ; Modulation Type: BPSK
 Separation Distance : 15 mm (The bottom side of the EUT to the Phantom)

DASY4 Configuration:

- Probe: EX3DV3 - SN3504 ; ConvF(7.53, 7.53, 7.53) ; Calibrated: 2009/1/21
- Sensor-Surface: 3mm (Mechanical Surface Detection)
- Electronics: DAE3 Sn510 ; Calibrated: 2009/1/21
- Phantom: SAM 12 ; Type: SAM V4.0; Serial: TP 1202
- Measurement SW: DASY4, V4.7 Build 80 ; Postprocessing SW: SEMCAD, V1.8 Build 186

Mid Channel 6/Area Scan (9x10x1): Measurement grid: dx=15mm, dy=15mm
 Maximum value of SAR (measured) = 0.188 mW/g

Mid Channel 6/Zoom Scan (7x7x7) (7x7x7)/Cube 0: Measurement grid: dx=5mm, dy=5mm, dz=5mm

Reference Value = 4.42 V/m

Peak SAR (extrapolated) = 0.271 W/kg

SAR(1 g) = 0.162 mW/g; SAR(10 g) = 0.102 mW/g

Maximum value of SAR (measured) = 0.190 mW/g

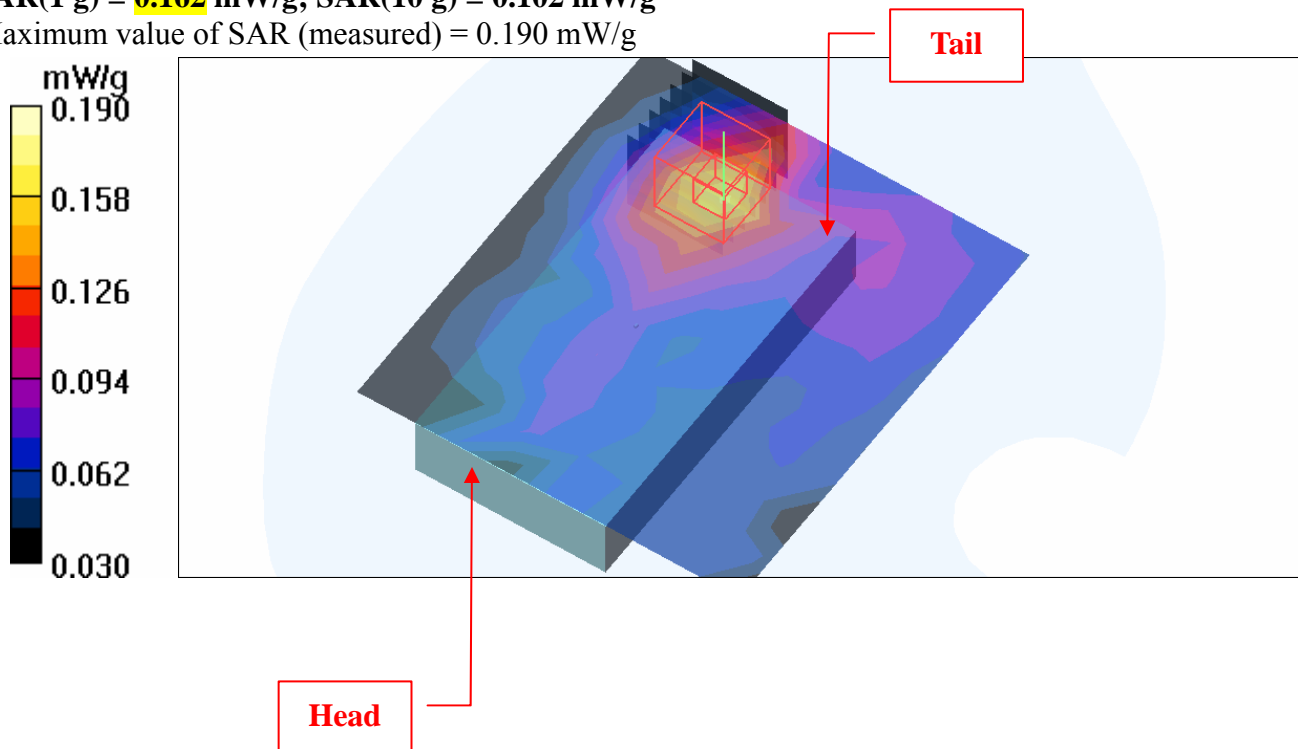

Test Laboratory: Bureau Veritas ADT

M16-Body-11g-Ch6 Slider-on LCD UP

DUT: Pocket PC Phone ; Type: RHOD500

Communication System: 802.11g ; Frequency: 2437 MHz ; Duty Cycle: 1:1

Medium: MSL2450 Medium parameters used: $f = 2437$ MHz; $\sigma = 1.93$ mho/m; $\epsilon_r = 54.7$; $\rho = 1000$ kg/m³

Phantom section: Flat Section ; DUT test position : Body ; Modulation Type: BPSK

Separation Distance : 15 mm (The front side of the EUT to the Phantom)

DASY4 Configuration:

- Probe: EX3DV3 - SN3504 ; ConvF(7.53, 7.53, 7.53) ; Calibrated: 2009/1/21
- Sensor-Surface: 3mm (Mechanical Surface Detection)
- Electronics: DAE3 Sn510 ; Calibrated: 2009/1/21
- Phantom: SAM 12 ; Type: SAM V4.0; Serial: TP 1202
- Measurement SW: DASY4, V4.7 Build 80 ; Postprocessing SW: SEMCAD, V1.8 Build 186

Mid Channel 6/Area Scan (9x10x1): Measurement grid: dx=15mm, dy=15mm

Maximum value of SAR (measured) = 0.011 mW/g

Mid Channel 6/Zoom Scan (7x7x7) (7x7x7)/Cube 0: Measurement grid: dx=5mm, dy=5mm, dz=5mm

Reference Value = 0.642 V/m

Peak SAR (extrapolated) = 0.051 W/kg

SAR(1 g) = 0.012 mW/g; SAR(10 g) = 0.00544 mW/g

Maximum value of SAR (measured) = 0.014 mW/g

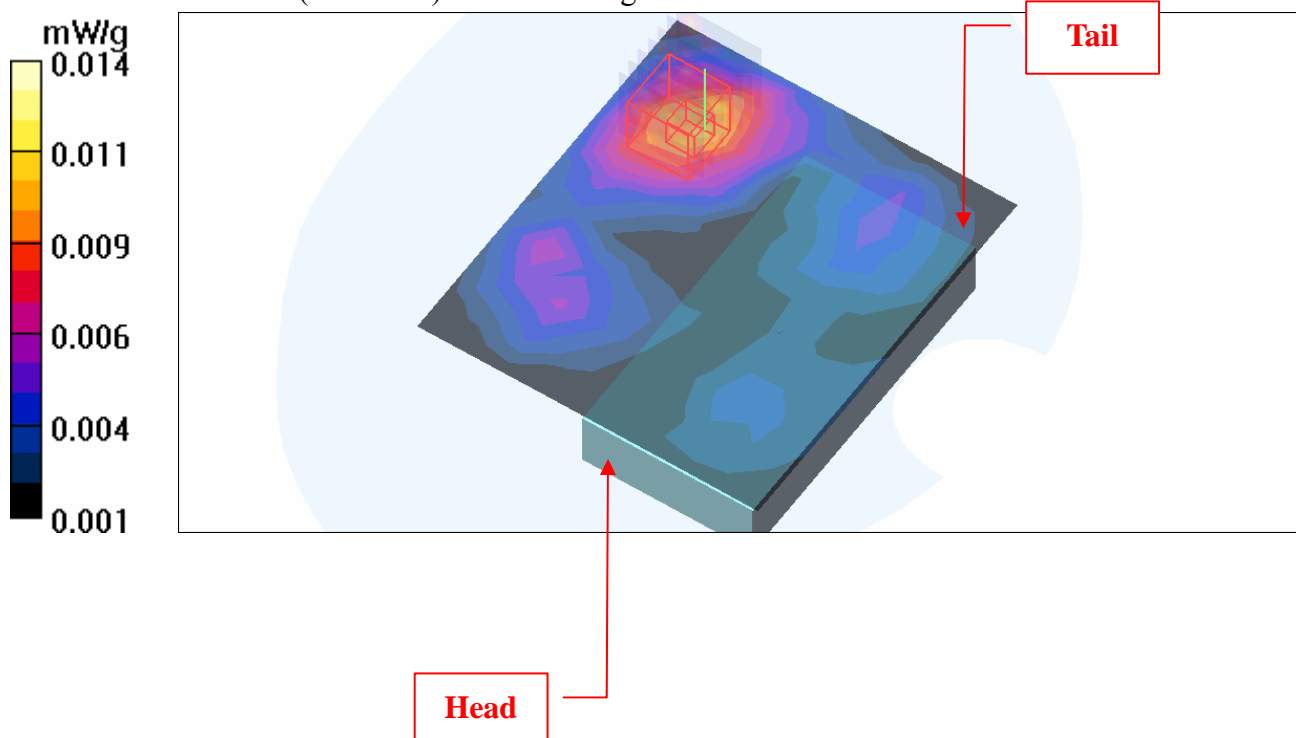

Test Laboratory: Bureau Veritas ADT

System Validation Check-HSL 2450MHz

DUT: Dipole 2450 MHz ; Type: D2450V2 ; Serial: 737 ; Test Frequency: 2450 MHz

Communication System: CW ; Frequency: 2450 MHz; Duty Cycle: 1:1; Modulation type: CW
Medium: HSL2450; Medium parameters used: $f = 2450$ MHz; $\sigma = 1.79$ mho/m; $\epsilon_r = 40$; $\rho = 1000$ kg/m³ ;
Liquid level : 151 mm
Phantom section: Flat Section ; Separation distance : 10 mm (The feetpoint of the dipole to the Phantom)
Air temp. : 22.3 degrees ; Liquid temp. : 21.2 degrees

DASY4 Configuration:

- Probe: EX3DV3 - SN3504 ; ConvF(7.67, 7.67, 7.67) ; Calibrated: 2009/1/21
- Sensor-Surface: 3mm (Mechanical Surface Detection)
- Electronics: DAE3 Sn510 ; Calibrated: 2009/1/21
- Phantom: SAM 12; Type: SAM V4.0; Serial: TP 1202
- Measurement SW: DASY4, V4.7 Build 80; Postprocessing SW: SEMCAD, V1.8 Build 186

d=10mm, Pin=250mW/Area Scan (5x7x1): Measurement grid: dx=15mm, dy=15mm
Maximum value of SAR (measured) = 16.5 mW/g

d=10mm, Pin=250mW/Zoom Scan (7x7x7)/Cube 0: Measurement grid: dx=5mm, dy=5mm, dz=5mm

Reference Value = 97.1 V/m; Power Drift = -0.009 dB

Peak SAR (extrapolated) = 28.9 W/kg

SAR(1 g) = 13.3 mW/g; SAR(10 g) = 6.05 mW/g

Maximum value of SAR (measured) = 16.4 mW/g

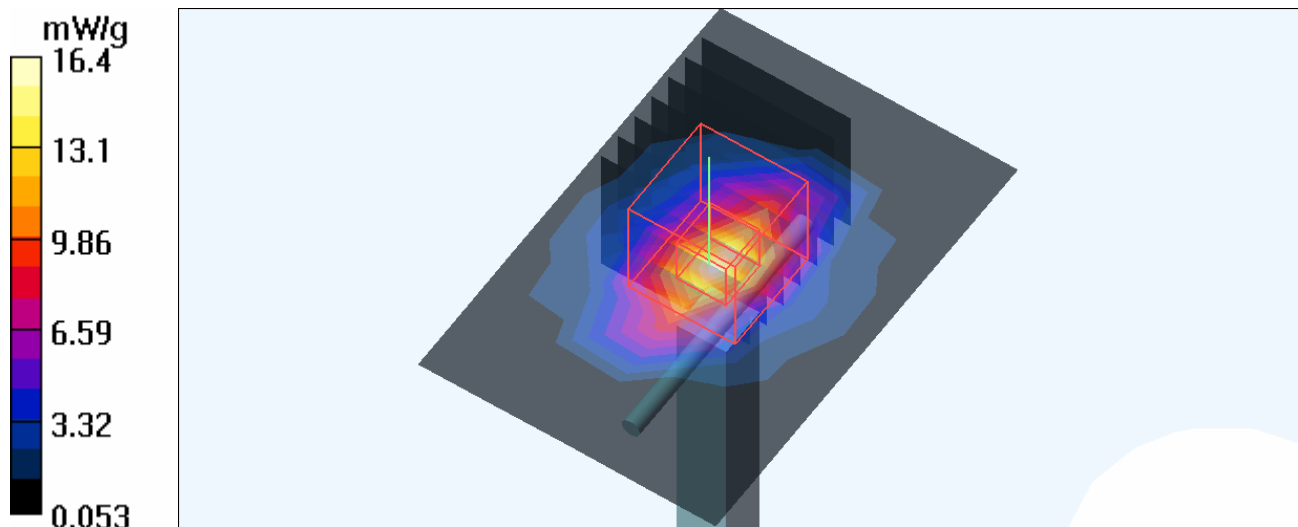

Test Laboratory: Bureau Veritas ADT

System Validation Check-MSL 2450MHz

DUT: Dipole 2450 MHz ; Type: D2450V2 ; Serial: 737 ; Test Frequency: 2450 MHz

Communication System: CW ; Frequency: 2450 MHz; Duty Cycle: 1:1; Modulation type: CW
Medium: MSL2450; Medium parameters used: $f = 2450$ MHz; $\sigma = 1.95$ mho/m; $\epsilon_r = 54.6$; $\rho = 1000$ kg/m³ ; Liquid level : 150 mm
Phantom section: Flat Section ; Separation distance : 10 mm (The feetpoint of the dipole to the Phantom) Air temp. : 22.6 degrees ; Liquid temp. : 21.3 degrees

DASY4 Configuration:

- Probe: EX3DV3 - SN3504 ; ConvF(7.53, 7.53, 7.53) ; Calibrated: 2009/1/21
- Sensor-Surface: 3mm (Mechanical Surface Detection)
- Electronics: DAE3 Sn510 ; Calibrated: 2009/1/21
- Phantom: SAM 12; Type: SAM V4.0; Serial: TP 1202
- Measurement SW: DASY4, V4.7 Build 80; Postprocessing SW: SEMCAD, V1.8 Build 186

d=10mm, Pin=250mW/Area Scan (5x7x1): Measurement grid: dx=15mm, dy=15mm
Maximum value of SAR (measured) = 15.4 mW/g

d=10mm, Pin=250mW/Zoom Scan (7x7x7)/Cube 0: Measurement grid: dx=5mm, dy=5mm, dz=5mm

Reference Value = 91.4 V/m; Power Drift = -0.114 dB

Peak SAR (extrapolated) = 22.9 W/kg

SAR(1 g) = 12.7 mW/g; SAR(10 g) = 5.89 mW/g

Maximum value of SAR (measured) = 15.3 mW/g

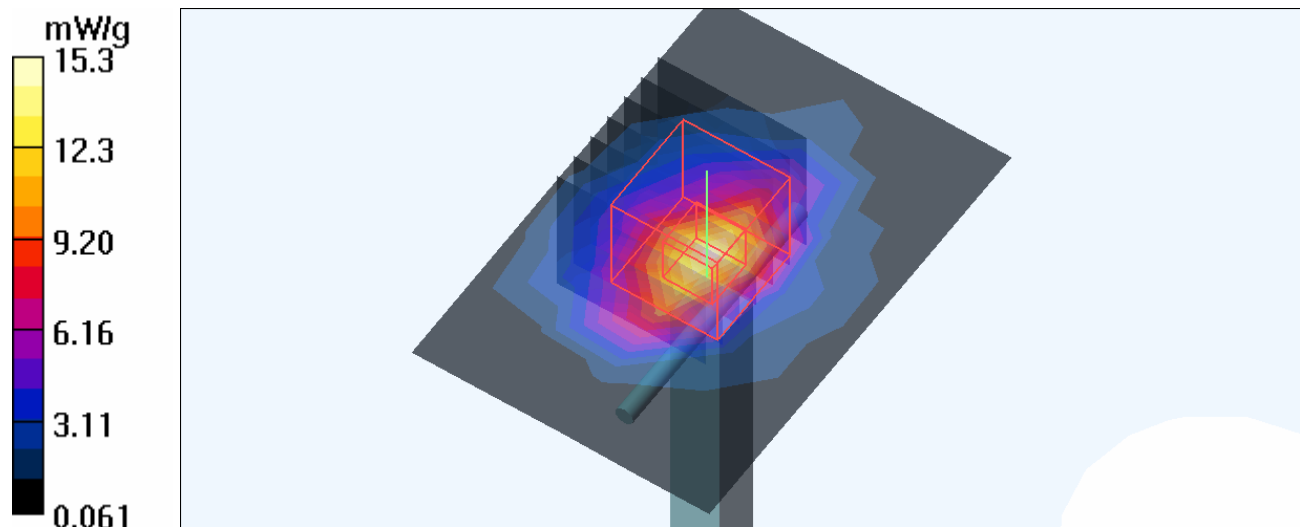

APPENDIX B: ADT SAR MEASUREMENT SYSTEM



APPENDIX C: PHOTOGRAPHS OF SYSTEM VALIDATION





APPENDIX D: SYSTEM CERTIFICATE & CALIBRATION

D1: PHANTOM



APPENDIX D: SYSTEM CERTIFICATE & CALIBRATION

D1: SAM PHANTOM

Schmid & Partner Engineering AG

Zeughausstrasse 43, 8004 Zurich, Switzerland, Phone +41 1 245 97 00, Fax +41 1 245 97 79

Certificate of conformity / First Article Inspection

Item	SAM Twin Phantom V4.0
Type No	QD 000 P40 CA
Series No	TP-1150 and higher
Manufacturer / Origin	Untersee Composites Hauptstr. 69 CH-8559 Fruthwilen Switzerland

Tests

The series production process used allows the limitation to test of first articles. Complete tests were made on the pre-series Type No. QD 000 P40 AA, Serial No. TP-1001 and on the series first article Type No. QD 000 P40 BA, Serial No. TP-1006. Certain parameters have been retested using further series units (called samples).

Test	Requirement	Details	Units tested
Shape	Compliance with the geometry according to the CAD model.	IT'IS CAD File (*)	First article, Samples
Material thickness	Compliant with the requirements according to the standards	2mm +/- 0.2mm in specific areas	First article, Samples
Material parameters	Dielectric parameters for required frequencies	200 MHz - 3 GHz Relative permittivity < 5 Loss tangent < 0.05.	Material sample TP 104-5
Material resistivity	The material has been tested to be compatible with the liquids defined in the standards	Liquid type HSL 1800 and others according to the standard.	Pre-series, First article

Standards

- [1] CENELEC EN 50361
- [2] IEEE P1528-200x draft 6.5
- [3] IEC PT 62209 draft 0.9

(*) The IT'IS CAD file is derived from [2] and is also within the tolerance requirements of the shapes of [1] and [3].

Conformity

Based on the sample tests above, we certify that this item is in compliance with the uncertainty requirements of SAR measurements specified in standard [1] and draft standards [2] and [3].

Date

28.02.2002

Signature / Stamp

F. Bumbult

**Schmid & Partner
Engineering AG**

Zeughausstrasse 43, CH-8004 Zurich
Tel. +41 1 245 97 00, Fax +41 1 245 97 79

Volker Kapp