



SAR TEST REPORT (MOBILE)

REPORT NO.: SA980116L05-1

MODEL NO.: RHOD500

RECEIVED: Feb. 05, 2009

TESTED: Apr. 04 ~ Apr. 05, 2009

ISSUED: Apr. 16, 2009

APPLICANT: HTC Corporation

ADDRESS: No. 23, Xinghua Rd., Taoyuan City, 330, Taiwan,
R.O.C.

ISSUED BY: Bureau Veritas Consumer Products Services (H.K.)
Ltd., Taoyuan Branch

LAB ADDRESS: No. 47, 14th Ling, Chia Pau Tsuen, Lin Kou Hsiang,
Taipei Hsien 244, Taiwan, R.O.C.

TEST LOCATION: No. 19, Hwa Ya 2nd Rd, Wen Hwa Tsuen, Kwei
Shan Hsiang, Taoyuan Hsien 333, Taiwan, R.O.C.

This test report consists of 54pages in total except Appendix. It may be duplicated completely for legal use with the approval of the applicant. It should not be reproduced except in full, without the written approval of our laboratory. The client should not use it to claim product endorsement by TAF or any government agencies. The test results in the report only apply to the tested sample.





TABLE OF CONTENTS

- 1. CERTIFICATION 3
- 2. GENERAL INFORMATION.....4
- 2.1 GENERAL DESCRIPTION OF EUT4
- 2.2 SAR MEASUREMENT CONDITIONS FOR CDMA.....7
- 2.3 GENERAL DESCRIPTION OF APPLIED STANDARDS 10
- 2.4 GENERAL INFORMATION OF THE SAR SYSTEM 11
- 2.5 GENERAL DESCRIPTION OF THE SPATIAL PEAK SAR EVALUATION 14
- 3. DESCRIPTION OF SUPPORT UNITS 17
- 4. DESCRIPTION OF TEST MODES AND CONFIGURATIONS 18
- 4.1. DESCRIPTION OF TEST POSITION 18
- 4.2.1 TOUCH/CHEEK TEST POSITION 19
- 4.2.2 TILT TEST POSITION 20
- 4.2.3 BODY-WORN CONFIGURATION 20
- 4.2. DESCRIPTION OF TEST MODE 21
- 4.3. DESCRIPTION OF ASSESSMENT POSITION 22
- 4.4. SUMMARY OF TEST RESULTS 22
- 5. TEST RESULTS 25
- 5.1 TEST PROCEDURES 25
- 5.2 MEASURED SAR RESULTS 27
- 5.3 SAR LIMITS..... 34
- 5.4 RECIPES FOR TISSUE SIMULATING LIQUIDS 35
- 5.5 TEST EQUIPMENT FOR TISSUE PROPERTY 41
- 6. SYSTEM VALIDATION 42
- 6.1 TEST EQUIPMENT 42
- 6.2 TEST PROCEDURE 43
- 6.3 VALIDATION RESULTS 45
- 6.4 SYSTEM VALIDATION UNCERTAINTIES 46
- 7. MEASUREMENT SAR PROCEDURE UNCERTAINTIES..... 47
- 7.1. PROBE CALIBRATION UNCERTAINTY 47
- 7.2. ISOTROPY UNCERTAINTY 48
- 7.3. BOUNDARY EFFECT UNCERTAINTY 48
- 7.4. PROBE LINEARITY UNCERTAINTY 49
- 7.5. READOUT ELECTRONICS UNCERTAINTY 49
- 7.6. RESPONSE TIME UNCERTAINTY 49
- 7.7. INTEGRATION TIME UNCERTAINTY 50
- 7.8. PROBE POSITIONER MECHANICAL TOLERANCE 51
- 7.9. PROBE POSITIONING 51
- 7.10. PHANTOM UNCERTAINTY 52
- 7.11. DASY4 UNCERTAINTY BUDGET 53
- 8. INFORMATION ON THE TESTING LABORATORIES 54

- APPENDIX A: TEST CONFIGURATIONS AND TEST DATA
- APPENDIX B: ADT SAR MEASUREMENT SYSTEM
- APPENDIX C: PHOTOGRAPHS OF SYSTEM VALIDATION
- APPENDIX D: SYSTEM CERTIFICATE & CALIBRATION



A D T

1. CERTIFICATION

PRODUCT: Pocket PC Phone
MODEL: RHOD500
APPLICANT: HTC Corporation
TESTED: Apr. 04 ~ Apr. 05, 2009
TEST SAMPLE: ENGINEERING SAMPLE
STANDARDS: **FCC Part 2 (Section 2.1093)**
FCC OET Bulletin 65, Supplement C (01-01)
RSS-102

The above equipment (model: RHOD500) has been tested by **Bureau Veritas Consumer Products Services (H.K.) Ltd., Taoyuan Branch**, and found compliance with the requirement of the above standards. The test record, data evaluation & Equipment Under Test (EUT) configurations represented herein are true and accurate accounts of the measurements of the sample's EMC characteristics under the conditions specified in this report.

PREPARED BY : Andrea Hsia , **DATE:** Apr. 16, 2009
Andrea Hsia / Specialist

TECHNICAL ACCEPTANCE : Long Chen , **DATE:** Apr. 16, 2009
Responsible for RF Long Chen / Senior Engineer

APPROVED BY : Gary Chang , **DATE:** Apr. 16, 2009
Gary Chang / Assistant Manager



2. GENERAL INFORMATION

2.1 GENERAL DESCRIPTION OF EUT

EUT	Pocket PC Phone	
MODEL NO.	RHOD500	
FCC ID	NM8RHOD500	
POWER SUPPLY	3.7Vdc from rechargeable lithium battery 5.0Vdc from power adapter 5.0Vdc from host equipment	
CLASSIFICATION	Portable device, production unit	
MODULATION TYPE	OQPSK, HPSK	
FREQUENCY RANGE	824MHz ~ 849MHz ; 1850MHz ~ 1910MHz	
CHANNEL FREQUENCIES UNDER TEST AND ITS CONDUCTED OUTPUT POWER	CDMA850 band:	
	SO55 RC3	0.230W / 836.5MHz for channel 384
	TDSO SO32 RC3	0.208W / 836.5MHz for channel 384
	1xEVDO	0.226W / 836.5MHz for channel 384
	CDMA1900 band:	
	SO55 RC3	0.246W / 1851.25MHz for channel 25
		0.224W / 1880.00MHz for channel 600
		0.253W / 1908.75MHz for channel 1175
	TDSO SO32 RC3	0.195W / 1880.00MHz for channel 600
	1xEVDO	0.214W / 1880.00MHz for channel 600
MAX. AVERAGE SAR (1g)	Head:	1.410W/kg
	Body:	0.589W/kg
ANTENNA TYPE	PIFA antenna with 0dBi gain (For 850 Band) PIFA antenna with 1dBi gain (For 1900 Band)	
DATA CABLE	1.25m non-shielded USB cable without core (Brand: MEC & ACON)	
I/O PORTS	Refer to user's manual	
ACCESSORY DEVICES	Adapter, Battery	

NOTE:

1. The EUT is a Pocket PC Phone. The functions of EUT listed as below:

	REFERENCE REPORT
CDMA 850 + CDMA 1900	SA980116L05-1
WLAN 802.11b/g	SA980116L05
BLUETOOTH	SA980116L05-2

2. The following accessory is for support units only.

PRODUCT	MODEL	DESCRIPTION
Earphone	HS G335	3.5mm connector 1.3m non-shielded without core

3. The communicated functions of EUT listed as below:

		850MHz	1900MHz	With WLAN 802.11b/g + BT 2.0 with EDR + GPS (CDMA rev. A)
3G	CDMA	√	√	
	1*EVDO	√	√	

4. The EUT uses following LCM panels.

PRODUCT	BRAND	MODEL
LCM (Main)	Auo	H361VL01
LCM (2nd source)	EID	L4F00390T00
LCM (3rd source)	Sharp	LS036Y1LX01

**LCM (Main) was found to be the worst case and was selected for the final test configuration.

5. The EUT uses following Cameras.

PRODUCT	BRAND	MODEL
Camera (Main)	FOXCONN	3M-AF
Camera (2nd source)	LITEON	08PM17

** Camera (Main) was found to be the worst case and was selected for the final test configuration.

6. For USB cable, after pre-tested found brand: ACON was the worst therefore chosen for the final test and presented in the test report.

7. The EUT uses following batteries.

BATTERY 1: (MANUFACTORY: WELLDONE)	
BRAND	hTC
MODEL	RHOD160
RATING	3.7Vdc, 1500mAh, 5.55Whr

BATTERY 2: (MANUFACTORY: FORMOSA)	
BRAND	hTC
MODEL	RHOD160
RATING	3.7Vdc, 1500mAh, 5.55Whr

BATTERY 3: (MANUFACTORY: SIMPLO)	
BRAND	hTC
MODEL	RHOD160
RATING	3.7Vdc, 1500mAh, 5.55Whr

**After pre-tested, battery 1 was the worst case for the final test and presented in the test report.

8. The EUT were operated with following power adapters:

ADAPTER 1 (MANUFACTORY: Delta)	
BRAND	hTC
MODEL	TC P300
INPUT	100-240Vac, 0.2A, 50-60Hz
OUTPUT	5Vdc, 1A
POWER LINE	1.25m non-shielded cable without core



ADAPTER 2 (MANUFACTORY: Foxlink) (second source)	
BRAND	hTC
MODEL	TC P300
INPUT	100-240Vac, 0.2A, 50-60Hz
OUTPUT	5Vdc, 1A
POWER LINE	1.25m non-shielded cable without core

9. Refer to following table for MEID no.:

MEID NO.
A1000007*****

10. Hardware version: NA

11. Software version: NA

12. The above EUT information was declared by manufacturer and for more detailed features description, please refer to the manufacturer's specifications or User's Manual.



2.2 SAR MEASUREMENT CONDITIONS FOR CDMA

The following procedures were followed according to FCC “SAR Measurement Procedures 3G Devices”, Oct. 2007.

➤ Output Power Verification

Maximum output power is verified on the High, Middle and Low channels according to procedures in section 4.4.5.2 of 3GPP2 C.S0011/TIA-98-E. Results for at least steps 3, 4 and 10 of the power measurement procedures should be tabulated in the SAR report. Steps 3 and 4 should be measured using SO55 with power control bits in “All Up” condition. TDSO / SO32 may be used instead of SO55 for step 4. Step 10 should be measured using TDSO / SO32 with power control bits in the “Bits Hold” condition (i.e. alternative Up/Down Bits). All power measurements defined in C.S0011/TIA-98-E that are inapplicable to the DUT or cannot be measured due to technical or equipment limitations should be clearly identified in the test report.6

➤ Head SAR Measurement

SAR for head exposure configurations is measured in RC3 with the DUT configured to transmit at full rate using Loopback Service Option SO55. SAR for RC1 is not required when the maximum average output of each channel is less than ¼ dB higher than that measured in RC3. Otherwise, SAR is measured on the maximum output channel in RC1 using the exposure configuration that results in the highest SAR for that channel in RC3.

➤ Body SAR Measurements

SAR for body exposure configurations is measured in RC3 with the DUT configured to transmit at full rate on FCH with all other code channels disabled using TDSO / SO32. SAR for multiple code channels (FCH + SCHn) is not required when the maximum average output of each RF channel is less than ¼ dB higher than that measured with FCH only. Otherwise, SAR is measured on the maximum output channel (FCH + SCHn) with FCH at full rate and SCH0 enabled at 9600 bps using the exposure configuration that results in the highest SAR for that channel with FCH only.

When multiple code channels are enabled, the DUT output may shift by more than 0.5 dB and lead to higher SAR drifts and SCH dropouts. Body SAR in RC1 is not required when the maximum average output of each channel is less than ¼ dB higher than that measured in RC3. Otherwise, SAR is measured on the maximum output channel in RC1; with Loopback Service Option SO55, at full rate, using the body exposure configuration that results in the highest SAR for that channel in RC3.



➤ **Handsets with Ev-Do**

For handsets with Ev-Do capabilities, when the maximum average output of each channel in Rev. 0 is less than ¼ dB higher than that measured in RC3 (1x RTT), body SAR for Ev-Do is not required. Otherwise, SAR for Rev. 0 is measured on the maximum output channel at **153.6 kbps** using the body exposure configuration that results in the highest SAR for that channel in RC3. SAR for Rev. A is not required when the maximum average output of each channel is less than that measured in Rev. 0 or less than ¼ dB higher than that measured in RC3. Otherwise, SAR is measured on the maximum output channel for Rev. A using a Reverse Data Channel payload size of 4096 bits and a Termination Target of 16 slots defined for Subtype 2 Physical Layer configurations. A Forward Traffic Channel data rate corresponding to the 2-slot version of 307.2 kbps with the ACK Channel transmitting in all slots should be configured in the downlink for both Rev. 0 and Rev. A.

CDMA850 band:

CONDUCTED POWER (1x EV-DO)								
CHANNEL	FREQ. (MHz)	RAW VALUE (dBm)		CORR. FACTOR (dB)	OUTPUT POWER			
					RTAP		FTAP	
		RTAP	FTAP		dBm	Watt	dBm	Watt
1013	824.7	19.35	19.41	4.40	23.75	0.237	23.81	0.240
384	836.5	19.02	19.14	4.40	23.42	0.220	23.54	0.226
777	848.3	19.41	19.52	4.40	23.81	0.240	23.92	0.247

CONDUCTED POWER (1x EV-DO)							
CHANNEL	FREQ. (MHz)	Rev. A			Rev. 0		
		RETAP: 128kbps (dBm)	RETAP: 2048kbps (dBm)	RETAP: 12288kbps (dBm)	EVDO-UL: 9.6kbps (dBm)	EVDO-UL: 38.4kbps (dBm)	EVDO-UL: 153.6kbps (dBm)
1013	824.7	23.71	23.74	23.75	23.75	23.79	23.81
384	836.5	23.53	23.49	23.42	23.57	23.60	23.54
777	848.3	23.79	23.77	23.81	23.90	23.89	23.92

CDMA 2000 CONDUCTED POWER													
CHAN.	FREQ. (MHz)	CDMA 2000	RAW VALUE (dBm)					CORR. FACTOR (dB)	OUTPUT POWER (dBm)				
		RC	SO2	SO55	TDSO SO32 (FCH)	TDSO SO32 (FCH+ SCH)	SO3		SO2	SO55	TDSO SO32 (FCH)	TDSO SO32 (FCH+ SCH)	SO3
1013	824.7	RC1	19.12	19.33	-	-	19.32	4.40	23.52	23.73	-	-	23.72
		RC3	19.19	19.45	18.96	18.88	19.42	4.40	23.59	23.85	23.36	23.28	23.82
384	836.5	RC1	18.89	19.18	-	-	19.15	4.40	23.29	23.58	-	-	23.55
		RC3	18.95	19.22	18.78	18.73	19.21	4.40	23.35	23.62	23.18	23.13	23.61
777	848.3	RC1	19.20	19.50	-	-	19.43	4.40	23.60	23.90	-	-	23.83
		RC3	19.25	19.62	19.28	19.20	19.52	4.40	23.65	24.02	23.68	23.60	23.92



CDMA1900 band:

CONDUCTED POWER (1x EV-DO)								
CHANNEL	FREQ. (MHz)	RAW VALUE (dBm)		CORR. FACTOR (dB)	OUTPUT POWER			
		Rev. A	Rev. 0		Rev. A		Rev. 0	
					dBm	Watt	dBm	Watt
25	1851.25	17.82	17.91	5.60	23.42	0.220	23.51	0.224
600	1880.00	17.66	17.71	5.60	23.26	0.212	23.31	0.214
1175	1908.75	17.89	17.96	5.60	23.49	0.223	23.56	0.227

CONDUCTED POWER (1x EV-DO)							
CHANNEL	FREQ. (MHz)	Rev. A			Rev. 0		
		RETAP: 128kbps (dBm)	RETAP: 2048kbps (dBm)	RETAP: 12288kbps (dBm)	EVDO-UL: 9.6kbps (dBm)	EVDO-UL: 38.4kbps (dBm)	EVDO-UL: 153.6kbps (dBm)
25	1851.25	23.38	23.40	23.42	23.49	23.48	23.51
600	1880.00	23.29	23.31	23.26	23.33	23.42	23.31
1175	1908.75	23.47	23.45	23.49	23.50	23.51	23.56

CDMA 2000 CONDUCTED POWER													
CHAN.	FREQ. (MHz)	CDMA 2000	RAW VALUE (dBm)					CORR. FACTOR (dB)	OUTPUT POWER (dBm)				
			RC	SO2	SO55	TDSO SO32 (FCH)	TDSO SO32 (FCH+ SCH)		SO3	SO2	SO55	TDSO SO32 (FCH)	TDSO SO32 (FCH+ SCH)
25	1851.25	RC1	17.77	18.21	-	-	18.05	5.60	23.37	23.81	-	-	23.65
		RC3	17.98	18.31	18.01	17.85	18.14	5.60	23.58	23.91	23.61	23.45	23.74
600	1880.00	RC1	17.33	17.66	-	-	17.55	5.60	22.93	23.26	-	-	23.15
		RC3	17.66	17.90	17.29	17.12	17.81	5.60	23.26	23.50	22.89	22.72	23.41
1175	1908.75	RC1	17.83	18.24	-	-	18.20	5.60	23.43	23.84	-	-	23.80
		RC3	18.06	18.43	18.11	17.91	18.24	5.60	23.66	24.03	23.71	23.51	23.84



A D T

2.3 GENERAL DESCRIPTION OF APPLIED STANDARDS

According to the specifications of the manufacturer, this product must comply with the requirements of the following standards:

FCC Part 2 (2.1093)

FCC OET Bulletin 65, Supplement C (01- 01)

RSS-102

IEEE 1528-2003

All test items have been performed and recorded as per the above standards.



2.4 GENERAL INFORMATION OF THE SAR SYSTEM

DASY4 (**software 4.7 Build 80**) consists of high precision robot, probe alignment sensor, phantom, robot controller, controlled measurement server and near-field probe. The robot includes six axes that can move to the precision position of the DASY4 software defined. The DASY4 software can define the area that is detected by the probe. The robot is connected to controlled box. Controlled measurement server is connected to the controlled robot box. The DAE includes amplifier, signal multiplexing, AD converter, offset measurement and surface detection. It is connected to the Electro-optical coupler (ECO). The ECO performs the conversion from the optical into digital electric signal of the DAE and transfers data to the PC.

EX3DV3 ISOTROPIC E-FIELD PROBE

CONSTRUCTION	Symmetrical design with triangular core Built-in shielding against static charges PEEK enclosure material (resistant to organic solvents, e.g., DGBE)
FREQUENCY	10 MHz to > 6 GHz Linearity: ± 0.2 dB (30 MHz to 6 GHz)
DIRECTIVITY	± 0.3 dB in HSL (rotation around probe axis) ± 0.5 dB in tissue material (rotation normal to probe axis)
DYNAMIC RANGE	10 μ W/g to > 100 mW/g Linearity: ± 0.2 dB (noise: typically < 1 μ W/g)
DIMENSIONS	Overall length: 330 mm (Tip: 20 mm) Tip diameter: 2.5 mm (Body: 12 mm) Typical distance from probe tip to dipole centers: 1 mm
APPLICATION	High precision dosimetric measurements in any exposure scenario (e.g., very strong gradient fields). Only probe which enables compliance testing for frequencies up to 6 GHz with precision of better 30%.

NOTE

1. The Probe parameters have been calibrated by the SPEAG. Please reference "APPENDIX D" for the Calibration Certification Report.
2. For frequencies above 800MHz, calibration in a rectangular wave-guide is used, because wave-guide size is manageable.
3. For frequencies below 800MHz, temperature transfer calibration is used because the wave-guide size becomes relatively large.



TWIN SAM V4.0

CONSTRUCTION

The shell corresponds to the specifications of the Specific Anthropomorphic Mannequin (SAM) phantom defined in IEEE 1528-2003, EN 62209-1 and IEC 62209. It enables the dosimetric evaluation of left and right hand phone usage as well as body mounted usage at the flat phantom region. A cover prevents evaporation of the liquid. Reference markings on the phantom allow the complete setup of all predefined phantom positions and measurement grids by manually teaching three points with the robot.

SHELL THICKNESS

2 ± 0.2mm

FILLING VOLUME

Approx. 25liters

DIMENSIONS

Height: 810mm; Length: 1000mm; Width: 500mm

SYSTEM VALIDATION KITS:

CONSTRUCTION

Symmetrical dipole with 1/4 balun enables measurement of feedpoint impedance with NWA matched for use near flat phantoms filled with brain simulating solutions. Includes distance holder and tripod adaptor

CALIBRATION

Calibrated SAR value for specified position and input power at the flat phantom in brain simulating solutions

FREQUENCY

835, 1900MHz

RETURN LOSS

> 20dB at specified validation position

POWER CAPABILITY

> 100W (f < 1GHz); > 40W (f > 1GHz)

OPTIONS

Dipoles for other frequencies or solutions and other calibration conditions upon request



DEVICE HOLDER FOR SAM TWIN PHANTOM

CONSTRUCTION

The device holder for the mobile phone device is designed to cope with different positions given in the standard. It has two scales for the device rotation (with respect to the body axis) and the device inclination (with respect to the line between the ear reference points). The rotation centers for both scales is the ear reference point (ERP). Thus the device needs no repositioning when changing the angles. The holder has been made out of low-loss POM material having the following dielectric parameters: relative permittivity $\varepsilon = 3$ and loss tangent $\delta = 0.02$. The amount of dielectric material has been reduced in the closest vicinity of the device, since measurements have suggested that the influence of the clamp on the test results could thus be lowered. The device holder for the portable device makes up of the polyethylene foam. The dielectric parameters of material close to the dielectric parameters of the air.

DATA ACQUISITION ELECTRONICS

CONSTRUCTION

The data acquisition electronics (DAE3) consists of a highly sensitive electrometer grade preamplifier with auto-zeroing, a channel and gain-switching multiplex, a fast 16 bit AD converter and a command decoder and control logic unit. Transmission to the measurement server is accomplished through an optical downlink for data and status information as well as an optical uplink for commands and the clock. The mechanical probe is mounting device includes two different sensor systems for frontal and sideways probe contacts. They are used for mechanical surface detection and probe collision detection. The input impedance of the DAE3 box is 200M Ω ; the inputs are symmetrical and floating. Common mode rejection is above 80 dB.



2.5 GENERAL DESCRIPTION OF THE SPATIAL PEAK SAR EVALUATION

The DASY4 post-processing software (SEMCAD) automatically executes the following procedures to calculate the field units from the micro-volt readings at the probe connector. The parameters used in the evaluation are stored in the configuration modules of the software:

Probe parameters:	- Sensitivity	Norm _i , a _{i0} , a _{i1} , a _{i2}
	- Conversion factor	ConvF _i
	- Diode compression point	dcp _i
Device parameters:	- Frequency	F
	- Crest factor	Cf
Media parameters:	- Conductivity	σ
	- Density	ρ

The first step of the evaluation is a linearization of the filtered input signal to account for the compression characteristics of the detector diode. The compensation depends on the input signal, the diode type and the DC-transmission factor from the diode to the evaluation electronics. If the exciting field is pulsed, the crest factor of the signal must be known to correctly compensate for peak power. The formula for each channel can be given as:

$$V_i = U_i + U_i^2 \cdot \frac{cf}{dcp_i}$$

V _i	=compensated signal of channel i	(i = x, y, z)
U _i	=input signal of channel I	(i = x, y, z)
Cf	=crest factor of exciting field	(DASY parameter)
dcp _i	=diode compression point	(DASY parameter)

From the compensated input signals the primary field data for each channel can be evaluated:

$$\text{E-field probes: } E_i = \sqrt{\frac{V_i}{\text{Norm}_i \cdot \text{ConvF}}}$$

$$\text{H-field probes: } H_i = \sqrt{V_i} \cdot \frac{a_{i0} + a_{i1}f + a_{i2}f^2}{f}$$

- V_i = compensated signal of channel i (i = x, y, z)
- Norm_i = sensor sensitivity of channel i $\mu\text{V}/(\text{V/m})^2$ for E-field Probes (i = x, y, z)
- ConvF = sensitivity enhancement in solution
- a_{ij} = sensor sensitivity factors for H-field probes
- f = carrier frequency [GHz]
- E_i = electric field strength of channel i in V/m
- H_i = magnetic field strength of channel i in A/m

The RSS value of the field components gives the total field strength (Hermitian magnitude):

$$E_{tot} = \sqrt{E_x^2 + E_y^2 + E_z^2}$$

The primary field data are used to calculate the derived field units.

$$SAR = E_{tot}^2 \cdot \frac{\sigma}{\rho \cdot 1'000}$$

- SAR = local specific absorption rate in mW/g
- E_{tot} = total field strength in V/m
- σ = conductivity in [mho/m] or [Siemens/m]
- ρ = equivalent tissue density in g/cm³



A D T

Note that the density is set to 1, to account for actual head tissue density rather than the density of the tissue simulating liquid. The entire evaluation of the spatial peak values is performed within the Post-processing engine (SEMCAD). The system always gives the maximum values for the 1g and 10g cubes. The algorithm to find the cube with highest averaged SAR is divided into the following stages:

1. The extraction of the measured data (grid and values) from the Zoom Scan
2. The calculation of the SAR value at every measurement point based on all stored data (A/D values and measurement parameters)
3. The generation of a high-resolution mesh within the measured volume
4. The interpolation of all measured values from the measurement grid to the high-resolution grid
5. The extrapolation of the entire 3-D field distribution to the phantom surface over the distance from sensor to surface
6. The calculation of the averaged SAR within masses of 1g and 10g.

The probe is calibrated at the center of the dipole sensors that is located 1 to 2.7mm away from the probe tip. During measurements, the probe stops shortly above the phantom surface, depending on the probe and the surface detecting system. Both distances are included as parameters in the probe configuration file. The software always knows exactly how far away the measured point is from the surface. As the probe cannot directly measure at the surface, the values between the deepest measured point and the surface must be extrapolated. The angle between the probe axis and the surface normal line is less than 30 degree.

The maximum search is automatically performed after each area scan measurement. It is based on splines in two or three dimensions. The procedure can find the maximum for most SAR distributions even with relatively large grid spacing. After the area scanning measurement, the probe is automatically moved to a position at the interpolated maximum. The following scan can directly use this position for reference, e.g., for a finer resolution grid or the cube evaluations. The 1g and 10g peak evaluations are only available for the predefined cube 7 x 7 x 7 scans. The routines are verified and optimized for the grid dimensions used in these cube measurements. The measured volume of 30 x 30 x 30mm contains about 30g of tissue. The first procedure is an extrapolation (incl. boundary correction) to get the points between the lowest measured plane and the surface. The next step uses 3D interpolation to get all points within the measured volume in a 1mm grid (42875 points). In the last



A D T

step, a 1g cube is placed numerically into the volume and its averaged SAR is calculated. This cube is the moved around until the highest averaged SAR is found. If the highest SAR is found at the edge of the measured volume, the system will issue a warning: higher SAR values might be found outside of the measured volume. In that case the cube measurement can be repeated, using the new interpolated maximum as the center.

3. DESCRIPTION OF SUPPORT UNITS

NO.	PRODUCT	BRAND	MODEL NO.	SERIAL NO.	CALIBRATED UNTIL
1	Universal Radio Communication Tester	R&S	CMU200	104484	Jan. 20, 2009

NO.	SIGNAL CABLE DESCRIPTION OF THE ABOVE SUPPORT UNITS
1	NA

NOTE: All power cords of the above support units are non shielded (1.8m).

4. DESCRIPTION OF TEST MODES AND CONFIGURATIONS

4.1. DESCRIPTION OF TEST POSITION

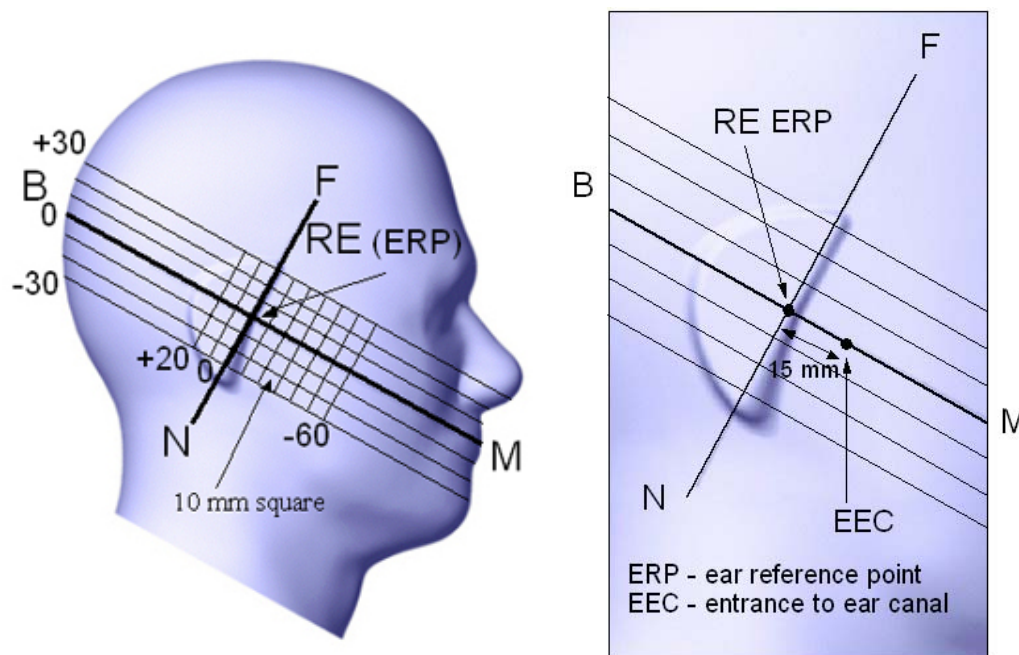

FIGURE 3.1

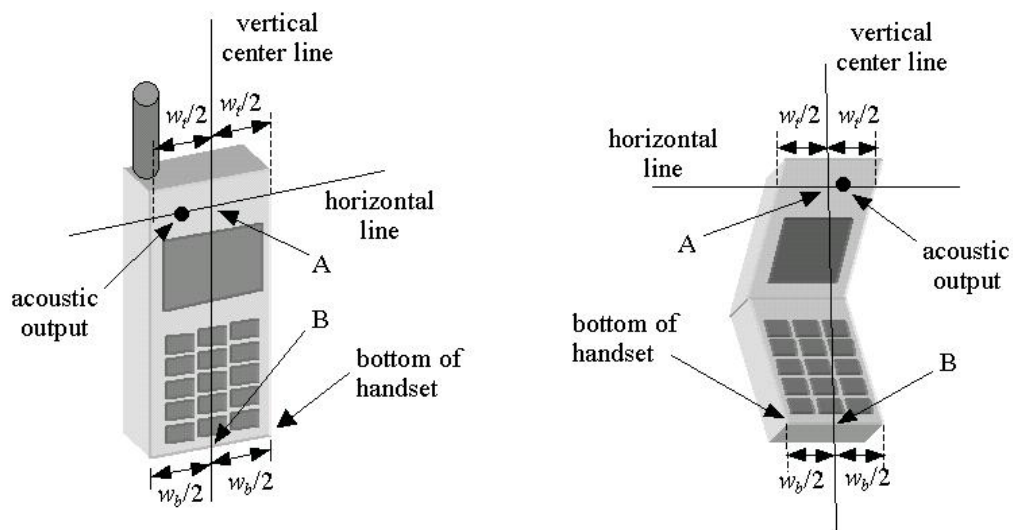
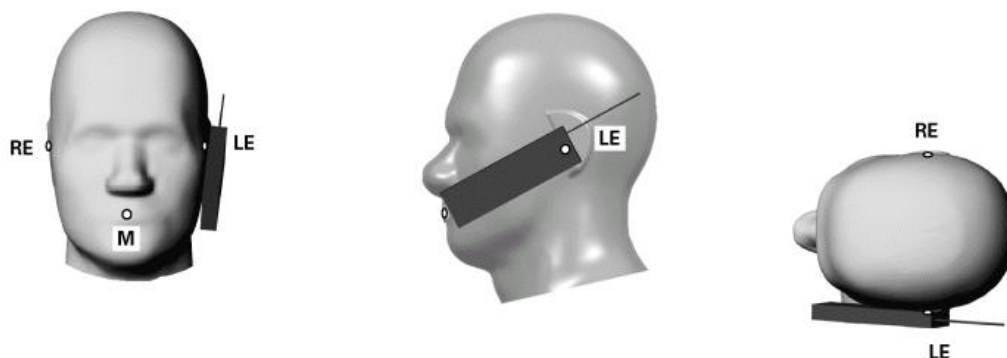

FIGURE 3.1a

FIGURE 3.1b

4.2.1 TOUCH/CHEEK TEST POSITION

The head position in Figure 3.1, the ear reference points ERP are 15mm above entrance to ear canal along the B-M line. The line N-F (Neck-Front) is perpendicular to the B-M (Back Mouth) line. The handset device in Figure 3.1a and 3.1b, The vertical centerline pass through two points on the front side of handset: the midpoint of the width w_t of the handset at the level of the acoustic output (point A) and the midpoint of the width w_b of the bottom of the handset (point B). The vertical centerline is perpendicular to the horizontal line and pass through the center of the acoustic output. The point A touches the ERP and the vertical centerline of the handset is parallel to the B-M line. While maintaining the point A contact with the ear(ERP), rotate the handset about the line NF until any point on handset is in contact with the cheek of the phantom



TOUCH/CHEEK POSITION FIGURE

4.2.2 TILT TEST POSITION

Adjust the device in the cheek position. While maintaining a point of the handset contact in the ear, move the bottom of the handset away from the mouth by an angle of 15 degrees.

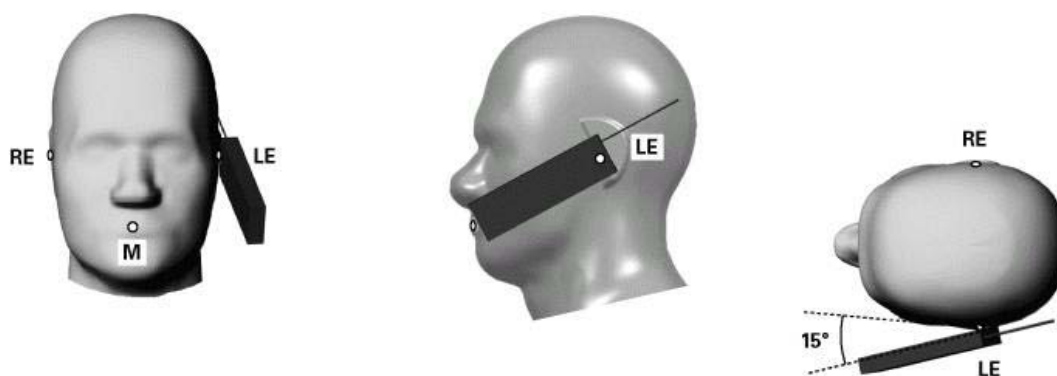

TILT POSITION FIGURE

4.2.3 BODY-WORN CONFIGURATION

The handset device attached the belt clip or the holster. The keypad face of the handset is against with the bottom of the flat phantom face and the bottom of the keypad face contact to the bottom of the flat phantom.

When multiple accessories that do not contain metallic components are supplied with the device, the device may be tested with only the accessory that dictates the closest spacing to the body. When multiple accessories that contain metallic components are supplied with the device, the device must be tested with each accessory that contains a unique metallic component. If multiple accessories share an identical metallic component (e.g., the same metallic belt-clip used with different holsters with no other metallic components), only accessory that dictates the closest spacing to the body must be tested.



4.2. DESCRIPTION OF TEST MODE

TEST MODE	COMMUNICATION MODE	MODULATION TYPE	ASSESSMENT POSITION	TESTED CHANNEL	REMARK
1	CDMA 850 SO55	OQPSK	A / Cheek	384	-
2			A / Tilt	384	-
3			B / Cheek	384	-
4			B / Tilt	384	-
5	CDMA 850 SO32	OQPSK	C : Body / Bottom	384	Slider off
6	1xEVDO 850 FTAP	HPSK	C : Body / Bottom	384	Slider off
7	CDMA 850 SO32	OQPSK	C : Body / Front	384	Slider off
8	1xEVDO 850 FTAP	HPSK	C : Body / Front	384	Slider off
9	CDMA 850 SO32	OQPSK	C : Body / Bottom	384	Slider on
10	1xEVDO 850 FTAP	HPSK	C : Body / Bottom	384	Slider on
11	CDMA 850 SO32	OQPSK	C : Body / Front	384	Slider on
12	1xEVDO 850 FTAP	HPSK	C : Body / Front	384	Slider on
13	CDMA 1900 SO55	OQPSK	A / Cheek	25, 600, 1175	-
14			A / Tilt	25, 600, 1175	-
15			B / Cheek	25, 600, 1175	-
16			B / Tilt	25, 600, 1175	-
17	CDMA 1900 SO55	OQPSK	B / Cheek	1175	For LCM (Brand: EID) (with Battery 1)
18	CDMA 1900 SO55	OQPSK	B / Cheek	1175	For LCM (Brand: Sharp) (with Battery 1)
19	CDMA 1900 SO55	OQPSK	B / Cheek	1175	For Battery 2 (Manufactory: FORMOSA) (with LCM brand : Auo)
20	CDMA 1900 SO55	OQPSK	B / Cheek	1175	For Battery 3 (Manufactory: SIMPLO) (with LCM brand : Auo)
21	CDMA 1900 SO32	OQPSK	C : Body / Bottom	600	Slider off
22	1xEVDO 1900	HPSK	C : Body / Bottom	600	Slider off
23	CDMA 1900 SO32	OQPSK	C : Body / Front	600	Slider off
24	1xEVDO 1900	HPSK	C : Body / Front	600	Slider off
25	CDMA 1900 SO32	OQPSK	C : Body / Bottom	600	Slider on
26	1xEVDO 1900	HPSK	C : Body / Bottom	600	Slider on
27	CDMA 1900 SO32	OQPSK	C : Body / Front	600	Slider on
28	1xEVDO 1900	HPSK	C : Body / Front	600	Slider on

NOTE 1: The Body position to the phantom with 15mm-separation distance.

NOTE 2: Test mode 1~ 16 & 21 ~ 28 used LCM brand: Auo; Battery 1 (Manufactory: WELLDONE)



4.3. DESCRIPTION OF ASSESSMENT POSITION

Assessment position A: Right head position, B: Left head position, C: Body position, please refer to appendix E for the photo.

4.4. SUMMARY OF TEST RESULTS

PART OF ASSESSMENT	HEAD POSITION			
COMMUNICATION MODE	CDMA850 SO55			
ITEM	1	2	3	4
	MEASURED VALUE OF 1g SAR (W/kg)			
	RIGHT		LEFT	
CHAN.	CHEEK	TILT	CHEEK	TILT
384	0.606	0.416	0.691	0.515

PART OF ASSESSMENT	BODY POSITION							
COMMUNICATION MODE	CDMA850 SO32	1xEVDO 850 FTAP	CDMA850 SO32	1xEVDO 850 FTAP	CDMA850 SO32	1xEVDO 850 FTAP	CDMA850 SO32	1xEVDO 850 FTAP
ITEM	5	6	7	8	9	10	11	12
	MEASURED VALUE OF 1g SAR (W/kg)							
	BOTTOM		FRONT		BOTTOM		FRONT	
CHAN.	BOTTOM		FRONT		BOTTOM		FRONT	
384	0.396	0.426	0.167	0.152	0.589	0.547	0.256	0.285

PART OF ASSESSMENT	HEAD POSITION			
COMMUNICATION MODE	CDMA1900 SO55			
ITEM	13	14	15	16
	MEASURED VALUE OF 1g SAR (W/kg)			
	RIGHT		LEFT	
CHAN.	CHEEK	TILT	CHEEK	TILT
25	0.849	1.060	1.090	0.901
600	0.858	0.916	1.070	0.870
1175	1.100	1.070	1.410	1.080



A D T

PART OF ASSESSMENT	HEAD POSITION			
COMMUNICATION MODE	CDMA1900 SO55	CDMA1900 SO55	CDMA1900 SO55	CDMA1900 SO55
ITEM	17	18	19	20
MEASURED VALUE OF 1g SAR (W/kg)				
LEFT				
CHAN.	CHEEK			
1175	1.290	1.320	1.340	1.370

PART OF ASSESSMENT	BODY POSITION							
COMMUNICATION MODE	CDMA1900 SO32	1xEVDO 1900 FTAP	CDMA1900 SO32	1xEVDO 1900 FTAP	CDMA1900 SO32	1xEVDO 1900 FTAP	CDMA1900 SO32	1xEVDO 1900 FTAP
ITEM	21	22	23	24	25	26	27	28
MEASURED VALUE OF 1g SAR (W/kg)								
CHAN.	BOTTOM		FRONT		BOTTOM		FRONT	
600	0.369	0.408	0.140	0.167	0.518	0.582	0.215	0.211

NOTE: The worst value has been marked by boldface.



Enhanced Energy Coupling At Increased Separation Distances

Initial Position:

The probe tip is positioned at the peak SAR location of high channel in test mode 15, at a distance of one half the probe tip diameter from the phantom surface. Under this condition to get a single SAR value.

5mm Increments from Initial Position:

With the probe fixed at this location, the device is moved away from the phantom in 5 mm increments from the initial touching or minimum separation position. A single point SAR is measured for each of these device positions until the SAR is less than 50% of that measured at the initial position.

TEST POSITION	SAR VALUE (mW/g)
INITIAL POSITION	2.437
5mm INCREMENTS FROM INITIAL POSITION	1.102

RESULT: No Enhancement Energy Coupling observed.



5. TEST RESULTS

5.1 TEST PROCEDURES

The EUT makes a phone call to the communication simulator station. Establish the simulation communication configuration rather the actual communication. Then the EUT could continuous the transmission mode. Adjust the PCL of the base station could controlled the EUT to transmitted the maximum output power. The base station also could control the transmission channel. The SAR value was calculated via the 3D spline interpolation algorithm that has been implemented in the software of DASY4 SAR measurement system manufactured and calibrated by SPEAG. According to the IEEE 1528 / EN 62209-1, the recommended procedure for assessing the peak spatial-average SAR value consists of the following steps:

- Power reference measurement
- Verification of the power reference measurement
- Area scan
- Zoom scan
- Power reference measurement

The area scan was performed for the highest spatial SAR location. The zoom scan with 30mm x 30mm x 30mm volume was performed for SAR value averaged over 1g and 10g spatial volumes.

In the zoom scan, the distance between the measurement point at the probe sensor location (geometric center behind the probe tip) and the phantom surface is 3mm and maintained at a constant distance of ± 0.5 mm during a zoom scan to determine peak SAR locations. The distance is 3mm between the first measurement point and the bottom surface of the phantom. The secondary measurement point to the bottom surface of the phantom is with 8mm separation distance. The cube size is 7 x 7 x 7 points consists of 343 points and the grid space is 5mm.



A D T

The measurement time is 0.5s at each point of the zoom scan. The probe boundary effect compensation shall be applied during the SAR test. Because of the tip of the probe to the Phantom surface separated distances are longer than half a tip probe diameter.

In the area scan, the separation distance is 3mm between the each measurement point and the phantom surface. The scan size shall be included the transmission portion of the EUT. The measurement time is the same as the zoom scan. At last the reference power drift shall be less than $\pm 5\%$.



A D T

5.2 MEASURED SAR RESULTS

CDMA850 BAND HEAD POSITION

ENVIRONMENTAL CONDITION		Air Temperature : 22.3°C, Liquid Temperature : 21.5°C Humidity : 60%RH					
TESTED BY		Sam Onn			DATE		Apr. 05, 2009
CHAN.	FREQ. (MHz)	MODULATION TYPE	CONDUCTED POWER (W)		POWER DRIFT (%)	DEVICE TEST POSITION MODE	MEASURED 1g SAR (W/kg)
			BEGIN TEST	AFTER TEST			
384	836.5 (Mid.)	OQPSK	0.230	0.227	-1.30	1	0.606
384	836.5 (Mid.)	OQPSK	0.230	0.226	-1.74	2	0.416
384	836.5 (Mid.)	OQPSK	0.230	0.225	-2.17	3	0.691
384	836.5 (Mid.)	OQPSK	0.230	0.224	-2.61	4	0.515

NOTE:

1. Test configuration of each mode is described in section 4.3.
2. In this testing, the limit for General Population Spatial Peak averaged over **1g, 1.6W/kg**, is applied.
3. Please see the Appendix A for the data.
4. The variation of the EUT conducted power measured before and after SAR testing should not over 5%.



A D T

**CDMA850 SO55 & EVDO850 FTAP
BAND BODY POSITION**

ENVIRONMENTAL CONDITION		Air Temperature : 22.7°C, Liquid Temperature : 21.6°C Humidity : 61%RH					
TESTED BY		Sam Onn			DATE	Apr. 05, 2009	
CHAN.	FREQ. (MHz)	MODULATION TYPE	CONDUCTED POWER (W)		POWER DRIFT (%)	DEVICE TEST POSITION MODE	MEASURED 1g SAR (W/kg)
			BEGIN TEST	AFTER TEST			
384	836.5 (Mid.)	OQPSK	0.208	0.202	-2.88	5	0.396
384	836.5 (Mid.)	HPSK	0.226	0.219	-3.10	6	0.426
384	836.5 (Mid.)	OQPSK	0.208	0.201	-3.37	7	0.167
384	836.5 (Mid.)	HPSK	0.226	0.218	-3.54	8	0.152
384	836.5 (Mid.)	OQPSK	0.208	0.200	-3.85	9	0.589
384	836.5 (Mid.)	HPSK	0.226	0.217	-3.98	10	0.547
384	836.5 (Mid.)	OQPSK	0.208	0.199	-4.33	11	0.256
384	836.5 (Mid.)	HPSK	0.226	0.217	-4.42	12	0.285

NOTE:

1. Test configuration of each mode is described in section 4.3.
2. In this testing, the limit for General Population Spatial Peak averaged over **1g, 1.6W/kg**, is applied.
3. Please see the Appendix A for the data.
4. The variation of the EUT conducted power measured before and after SAR testing should not over 5%.



A D T

CDMA 1900 BAND RIGHT HEAD POSITION

ENVIRONMENTAL CONDITION		Air Temperature : 22.9°C, Liquid Temperature : 21.8°C Humidity : 62%RH					
TESTED BY		Sam Onn			DATE		Apr. 04, 2009
CHAN.	FREQ. (MHz)	MODULATION TYPE	CONDUCTED POWER (W)		POWER DRIFT (%)	DEVICE TEST POSITION MODE	MEASURED 1g SAR (W/kg)
			BEGIN TEST	AFTER TEST			
25	1851.25 (Low)	OQPSK	0.246	0.224	-0.81	13	0.849
600	1880.00 (Mid.)	OQPSK	0.224	0.222	-0.89	13	0.858
1175	1908.75 (High)	OQPSK	0.253	0.250	-1.19	13	1.100
25	1851.25 (Low)	OQPSK	0.246	0.243	-1.22	14	1.060
600	1880.00 (Mid.)	OQPSK	0.224	0.221	-1.34	14	0.916
1175	1908.75 (High)	OQPSK	0.253	0.249	-1.58	14	1.070

NOTE:

1. Test configuration of each mode is described in section 4.3.
2. In this testing, the limit for General Population Spatial Peak averaged over **1g, 1.6W/kg**, is applied.
3. Please see the Appendix A for the data.
4. The variation of the EUT conducted power measured before and after SAR testing should not over 5%.



A D T

CDMA 1900 BAND LEFT HEAD POSITION

ENVIRONMENTAL CONDITION		Air Temperature : 22.9°C, Liquid Temperature : 21.8°C Humidity : 62%RH					
TESTED BY		Sam Onn			DATE		Apr. 04, 2009
CHAN.	FREQ. (MHz)	MODULATION TYPE	CONDUCTED POWER (W)		POWER DRIFT (%)	DEVICE TEST POSITION MODE	MEASURED 1g SAR (W/kg)
			BEGIN TEST	AFTER TEST			
25	1851.25 (Low)	OQPSK	0.246	0.242	-1.63	15	1.090
600	1880.00 (Mid.)	OQPSK	0.224	0.220	-1.79	15	1.070
1175	1908.75 (High)	OQPSK	0.253	0.248	-1.98	15	1.410
25	1851.25 (Low)	OQPSK	0.246	0.241	-2.03	16	0.901
600	1880.00 (Mid.)	OQPSK	0.224	0.219	-2.23	16	0.870
1175	1908.75 (High)	OQPSK	0.253	0.247	-2.37	16	1.080

NOTE:

1. Test configuration of each mode is described in section 4.3.
2. In this testing, the limit for General Population Spatial Peak averaged over **1g, 1.6W/kg**, is applied.
3. Please see the Appendix A for the data.
4. The variation of the EUT conducted power measured before and after SAR testing should not over 5%.



A D T

**CDMA 1900 BAND LEFT HEAD POSITION
(COMPARE WITH LCM 2ND & 3RD SOURCE)**

ENVIRONMENTAL CONDITION		Air Temperature : 22.9°C, Liquid Temperature : 21.8°C Humidity : 62%RH					
TESTED BY		Sam Onn			DATE		Apr. 04, 2009
CHAN.	FREQ. (MHz)	MODULATION TYPE	CONDUCTED POWER (W)		POWER DRIFT (%)	DEVICE TEST POSITION MODE	MEASURED 1g SAR (W/kg)
			BEGIN TEST	AFTER TEST			
1175	1908.75 (High)	OQPSK	0.253	0.251	-0.79	17	1.290
1175	1908.75 (High)	OQPSK	0.253	0.249	-1.58	18	1.320

NOTE:

1. Test configuration of each mode is described in section 4.3.
2. In this testing, the limit for General Population Spatial Peak averaged over **1g, 1.6W/kg**, is applied.
3. Please see the Appendix A for the data.
4. The variation of the EUT conducted power measured before and after SAR testing should not over 5%.



A D T

CDMA 1900 BAND LEFT HEAD POSITION (COMPARE WITH BATTERY 1 & BATTERY 3)

ENVIRONMENTAL CONDITION		Air Temperature : 22.9°C, Liquid Temperature : 21.8°C Humidity : 62%RH					
TESTED BY		Sam Onn			DATE		Apr. 04, 2009
CHAN.	FREQ. (MHz)	MODULATION TYPE	CONDUCTED POWER (W)		POWER DRIFT (%)	DEVICE TEST POSITION MODE	MEASURED 1g SAR (W/kg)
			BEGIN TEST	AFTER TEST			
1175	1908.75 (High)	OQPSK	0.253	0.250	-1.19	19	1.340
1175	1908.75 (High)	OQPSK	0.253	0.247	-2.37	20	1.370

NOTE:

1. Test configuration of each mode is described in section 4.3.
2. In this testing, the limit for General Population Spatial Peak averaged over **1g, 1.6W/kg**, is applied.
3. Please see the Appendix A for the data.
4. The variation of the EUT conducted power measured before and after SAR testing should not over 5%.



A D T

CDMA1900 SO55 & EVDO850 FTAP BAND BODY POSITION

ENVIRONMENTAL CONDITION		Air Temperature : 22.7°C, Liquid Temperature : 21.5°C Humidity : 62%RH					
TESTED BY		Sam Onn			DATE	Apr. 04, 2009	
CHAN.	FREQ. (MHz)	MODULATION TYPE	CONDUCTED POWER (W)		POWER DRIFT (%)	DEVICE TEST POSITION MODE	MEASURED 1g SAR (W/kg)
			BEGIN TEST	AFTER TEST			
600	1880.00 (Mid.)	OQPSK	0.195	0.193	-1.03	21	0.369
600	1880.00 (Mid.)	HPSK	0.214	0.211	-1.40	22	0.408
600	1880.00 (Mid.)	OQPSK	0.195	0.192	-1.54	23	0.140
600	1880.00 (Mid.)	HPSK	0.214	0.210	-1.87	24	0.167
600	1880.00 (Mid.)	OQPSK	0.195	0.191	-2.05	25	0.518
600	1880.00 (Mid.)	HPSK	0.214	0.209	-2.34	26	0.582
600	1880.00 (Mid.)	OQPSK	0.195	0.190	-2.56	27	0.215
600	1880.00 (Mid.)	HPSK	0.214	0.208	-2.80	28	0.211

NOTE:

1. Test configuration of each mode is described in section 4.3.
2. In this testing, the limit for General Population Spatial Peak averaged over **1g, 1.6W/kg**, is applied.
3. Please see the Appendix A for the data.
4. The variation of the EUT conducted power measured before and after SAR testing should not over 5%.



5.3 SAR LIMITS

HUMAN EXPOSURE	SAR (W/kg)	
	(GENERAL POPULATION / UNCONTROLLED EXPOSURE ENVIRONMENT)	(OCCUPATIONAL / CONTROLLED EXPOSURE ENVIRONMENT)
Spatial Average (whole body)	0.08	0.4
Spatial Peak (averaged over 1 g)	1.6	8.0
Spatial Peak (hands / wrists / feet / ankles averaged over 10 g)	4.0	20.0

NOTE:

1. This limits accord to 47 CFR 2.1093 – Safety Limit.
2. The EUT property been complied with the partial body exposure limit under the general population environment.



5.4 RECIPES FOR TISSUE SIMULATING LIQUIDS

For the measurement of the field distribution inside the SAM phantom, the phantom must be filled with 25 liters of tissue simulation liquid.

The following ingredients are used :

- **WATER-** Deionized water (pure H₂O), resistivity ≈ 16 M - as basis for the liquid
- **SUGAR-** Refined sugar in crystals, as available in food shops - to reduce relative permittivity
- **SALT-** Pure NaCl - to increase conductivity
- **CELLULOSE-** Hydroxyethyl-cellulose, medium viscosity (75-125mPa.s, 2% in water, 20_C),
CAS # 54290 - to increase viscosity and to keep sugar in solution
- **PRESERVATIVE-** Preventol D-7 Bayer AG, D-51368 Leverkusen, CAS # 55965-84-9 - to prevent the spread of bacteria and molds
- **DGMBE-** Diethylenglycol-monobuthyl ether (DGMBE), Fluka Chemie GmbH, CAS # 112-34-5 - to reduce relative permittivity

THE RECIPES FOR 835MHz SIMULATING LIQUID TABLE

INGREDIENT	HEAD SIMULATING LIQUID 835MHz (HSL-835)	MUSCLE SIMULATING LIQUID 835MHz (MSL-835)
Water	40.28%	50.07%
Cellulose	02.41%	NA
Salt	01.38%	0.94%
Preventtol D-7	00.18%	0.09%
Sugar	57.97%	48.2%
Dielectric Parameters at 22°C	f = 835MHz $\epsilon = 41.5 \pm 5\%$ $\sigma = 0.97 \pm 5\%$ S/m	f = 835MHz $\epsilon = 55.0 \pm 5\%$ $\sigma = 1.05 \pm 5\%$ S/m



THE RECIPES FOR 1900MHz SIMULATING LIQUID TABLE

INGREDIENT	HEAD SIMULATING LIQUID 1900MHz (HSL-1900)	MUSCLE SIMULATING LIQUID 1900MHz (MSL-1900)
Water	55.24%	70.16%
DGMBE	44.45%	29.44%
Salt	0.306%	00.39%
Dielectric Parameters at 22°C	f= 1900MHz $\epsilon= 40.0 \pm 5\%$ $\sigma= 1.40 \pm 5\%$ S/m	f= 1900MHz $\epsilon= 53.3 \pm 5\%$ $\sigma= 1.52 \pm 5\%$ S/m



A D T

Testing the liquids using the Agilent Network Analyzer E8358A and Agilent Dielectric Probe Kit 85070D. The testing procedure is following as

1. Turn Network Analyzer on and allow at least 30min. warm up.
2. Mount dielectric probe kit so that interconnecting cable to Network Analyzer will not be moved during measurements or calibration.
3. Pour de-ionized water and measure water temperature ($\pm 1^\circ$).
4. Set water temperature in Agilent-Software (Calibration Setup).
5. Perform calibration.
6. Validate calibration with dielectric material of known properties (e.g. polished ceramic slab with $>8\text{mm}$ thickness $\epsilon' = 10.0$, $\epsilon'' = 0.0$). If measured parameters do not fit within tolerance, repeat calibration (± 0.2 for ϵ' : ± 0.1 for ϵ'').
7. Conductivity can be calculated from ϵ'' by $\sigma = \omega \epsilon_0 \epsilon'' = \epsilon'' f [\text{GHz}] / 18$.
8. Measure liquid shortly after calibration. Repeat calibration every hour.
9. Stir the liquid to be measured. Take a sample ($\sim 50\text{ml}$) with a syringe from the center of the liquid container.
10. Pour the liquid into a small glass flask. Hold the syringe at the bottom of the flask to avoid air bubbles.
11. Put the dielectric probe in the glass flask. Check that there are no air bubbles in front of the opening in the dielectric probe kit.
12. Perform measurements.
13. Adjust medium parameters in DASY4 for the frequencies necessary for the measurements ('Setup Config', select medium (e.g. Brain 900MHz) and press 'Option'-button.
14. Select the current medium for the frequency of the validation (e.g. Setup Medium Brain 900MHz).



A D T

FOR CDMA 850 BAND SIMULATING LIQUID

LIQUID TYPE		HSL-835		
SIMULATING LIQUID TEMP.		21.5		
TEST DATE		Apr. 05, 2009		
TESTED BY		Sam Onn		
FREQ. (MHz)	LIQUID PARAMETER	STANDARD VALUE	MEASUREMENT VALUE	ERROR PERCENTAGE (%)
835.0	Permittivity (ϵ)	41.50	42.90	3.37
836.5		41.50	42.90	3.37
835.0	Conductivity (σ) S/m	0.90	0.90	0.00
836.5		0.90	0.90	0.00
Dielectric Parameters Required at 22°C		f= 835MHz $\epsilon= 41.5 \pm 5\%$ $\sigma= 0.97 \pm 5\%$ S/m		

LIQUID TYPE		MSL-835		
SIMULATING LIQUID TEMP.		21.6		
TEST DATE		Apr. 05, 2009		
TESTED BY		Sam Onn		
FREQ. (MHz)	LIQUID PARAMETER	STANDARD VALUE	MEASUREMENT VALUE	ERROR PERCENTAGE (%)
835.0	Permittivity (ϵ)	55.20	55.90	1.27
836.5		55.20	55.80	1.09
835.0	Conductivity (σ) S/m	0.97	0.98	1.03
836.5		0.97	0.98	1.03
Dielectric Parameters Required at 22°C		f= 835MHz $\epsilon= 55.0 \pm 5\%$ $\sigma= 1.05 \pm 5\%$ S/m		



A D T

FOR CDMA 1900 BAND SIMULATING LIQUID

LIQUID TYPE		HSL-1900		
SIMULATING LIQUID TEMP.		21.8		
TEST DATE		Apr. 04, 2009		
TESTED BY		Sam Onn		
FREQ. (MHz)	LIQUID PARAMETER	STANDARD VALUE	MEASUREMENT VALUE	ERROR PERCENTAGE (%)
1851.25	Permittivity (ϵ)	40.00	40.60	1.50
1880.00		40.00	40.60	1.50
1900.00		40.00	40.50	1.25
1908.75		40.00	40.50	1.25
1851.25	Conductivity (σ) S/m	1.40	1.36	-2.86
1880.00		1.40	1.40	0.00
1900.00		1.40	1.42	1.43
1908.75		1.40	1.43	2.14
Dielectric Parameters Required at 22°C		f= 1900MHz $\epsilon= 40.0 \pm 5\%$ $\sigma= 1.40 \pm 5\% \text{ S/m}$		



A D T

LIQUID TYPE		MSL-1900		
SIMULATING LIQUID TEMP.		21.5		
TEST DATE		Apr. 04, 2009		
TESTED BY		Sam Onn		
FREQ. (MHz)	LIQUID PARAMETER	STANDARD VALUE	MEASUREMENT VALUE	ERROR PERCENTAGE (%)
1880.00	Permittivity (ϵ)	53.30	54.50	2.25
1900.00		53.30	54.40	2.06
1880.00	Conductivity (σ) S/m	1.52	1.52	0.00
1900.00		1.52	1.54	1.32
Dielectric Parameters Required at 22°C		f= 1900MHz $\epsilon= 40.0 \pm 5\%$ $\sigma= 1.40 \pm 5\%$ S/m		



A D T

5.5 TEST EQUIPMENT FOR TISSUE PROPERTY

ITEM	NAME	BRAND	TYPE	SERIES NO.	DATE OF CALIBRATION	DUE DATE OF CALIBRATION
1	Network Analyzer	Agilent	E8358A	US41480538	Nov. 27, 2008	Nov. 26, 2009
2	Dielectric Probe	Agilent	85070D	US01440176	NA	NA

NOTE:

1. Before starting, all test equipment shall be warmed up for 30min.
2. The tolerance (k=1) specified by Agilent for general dielectric measurements, deriving from inaccuracies in the calibration data, analyzer drift, and random errors, are usually $\pm 2.5\%$ and $\pm 5\%$ for measured permittivity and conductivity, respectively. However, the tolerances for the conductivity is smaller for material with large loss tangents, i.e., less than $\pm 2.5\%$ (k=1). It can be substantially smaller if more accurate methods are applied.



6. SYSTEM VALIDATION

The system validation was performed in the flat phantom with equipment listed in the following table. Since the SAR value is calculated from the measured electric field, dielectric constant and conductivity of the body tissue and the SAR is proportional to the square of the electric field. So, the SAR value will be also proportional to the RF power input to the system validation dipole under the same test environment. In our system validation test, 250mW RF input power was used.

6.1 TEST EQUIPMENT

ITEM	NAME	BRAND	TYPE	SERIES NO.	DATE OF CALIBRATION	DUE DATE OF CALIBRATION
1	SAM Phantom	S & P	QD000 P40 CA	TP-1150	NA	NA
2	Signal Generator	Anritsu	68247B	984703	May 27, 2008	May 26, 2009
3	E-Field Probe	S & P	EX3DV3	3504	Jan. 22, 2009	Jan. 21, 2010
4	DAE	S & P	DAE	510	Jan. 22, 2008	Jan. 21, 2010
5	Robot Positioner	Staubli Unimation	NA	NA	NA	NA
6	Validation Dipole	S & P	D835V2	4d021	May 11, 2008	May 12, 2009
7	Validation Dipole	S & P	D1900V2	5d036	Apr. 22, 2008	Apr. 21, 2009
8	Power Meter	Angilent	E4416A	GB41291763	Sep. 30, 2008	Sep. 29, 2009
9	Power Sensor		E9327A	US40441181	Sep. 30, 2008	Sep. 29, 2009

NOTE: Before starting the measurement, all test equipment shall be warmed up for 30min.



6.2 TEST PROCEDURE

Before the system performance check, we need only to tell the system which components (probe, medium, and device) are used for the system performance check; the system will take care of all parameters. The dipole must be placed beneath the flat section of the SAM Twin Phantom with the correct distance holder in place. The distance holder should touch the phantom surface with a light pressure at the reference marking (little cross) and be oriented parallel to the long side of the phantom. Accurate positioning is not necessary, since the system will search for the peak SAR location, except that the dipole arms should be parallel to the surface. The device holder for mobile phones can be left in place but should be rotated away from the dipole.

1. The "Power Reference Measurement" and "Power Drift Measurement" jobs are located at the beginning and end of the batch process. They measure the field drift at one single point in the liquid over the complete procedure. The indicated drift is mainly the variation of the amplifier output power. If it is too high (above ± 0.1 dB), the system performance check should be repeated; some amplifiers have very high drift during warm-up. A stable amplifier gives drift results in the DASY system below ± 0.02 dB.
2. The "Surface Check" job tests the optical surface detection system of the DASY system by repeatedly detecting the surface with the optical and mechanical surface detector and comparing the results. The output gives the detecting heights of both systems, the difference between the two systems and the standard deviation of the detection repeatability. Air bubbles or refraction in the liquid due to separation of the sugar-water mixture gives poor repeatability (above ± 0.1 mm). In that case it is better to abort the system performance check and stir the liquid.



A D T

3. The "Area Scan" job measures the SAR above the dipole on a plane parallel to the surface. It is used to locate the approximate location of the peak SAR. The proposed scan uses large grid spacing for faster measurement; due to the symmetric field, the peak detection is reliable. If a finer graphic is desired, the grid spacing can be reduced. Grid spacing and orientation have no influence on the SAR result.
4. The "Zoom Scan" job measures the field in a volume around the peak SAR value assessed in the previous "Area Scan" job (for more information see the application note on SAR evaluation).

About the validation dipole positioning uncertainty, the constant and low loss dielectric spacer is used to establish the correct distance between the top surface of the dipole and the bottom surface of the phantom, the error component introduced by the uncertainty of the distance between the liquid (i.e., phantom shell) and the validation dipole in the DASY4 system is less than ± 0.1 mm.

$$SAR_{tolerance} [\%] = 100 \times \left(\frac{(a + d)^2}{a^2} - 1 \right)$$

As the closest distance is 10mm, the resulting tolerance $SAR_{tolerance} [\%]$ is <2%.



6.3 VALIDATION RESULTS

SYSTEM VALIDATION TEST OF SIMULATING LIQUID					
FREQUENCY (MHz)	REQUIRED SAR (mW/g)	MEASURED SAR (mW/g)	DEVIATION (%)	SEPARATION DISTANCE	TESTED DATE
HSL835	2.31 (1g)	2.37	2.60	15mm	Apr. 05, 2009
MSL835	2.34 (1g)	2.37	1.28	15mm	Apr. 05, 2009
HSL1900	10.20 (1g)	10.10	-0.98	10mm	Apr. 04, 2009
MSL1900	10.20 (1g)	9.65	-5.39	10mm	Apr. 04, 2009
TESTED BY	Sam Onn				

NOTE: Please see Appendix for the photo of system validation test.



6.4 SYSTEM VALIDATION UNCERTAINTIES

In the table below, the system validation uncertainty with respect to the analytically assessed SAR value of a dipole source as given in the IEEE 1528 standard is given. This uncertainty is smaller than the expected uncertainty for mobile phone measurements due to the simplified setup and the symmetric field distribution.

Error Description	Tolerance (±%)	Probability Distribution	Divisor	(C _i)		Standard Uncertainty (±%)		(v _i)
				(1g)	(10g)	(1g)	(10g)	
Measurement System								
Probe Calibration	5.50	Normal	1	1	1	5.50	5.50	∞
Axial Isotropy	4.70	Rectangular	√3	0.7	0.7	1.90	1.90	∞
Hemispherical Isotropy	9.60	Rectangular	√3	0.7	0.7	3.88	3.88	∞
Boundary effects	1.00	Rectangular	√3	1	1	0.58	0.58	∞
Linearity	4.70	Rectangular	√3	1	1	2.71	2.71	∞
System Detection Limits	1.00	Rectangular	√3	1	1	0.58	0.58	∞
Readout Electronics	0.30	Normal	1	1	1	0.30	0.30	∞
Response Time	0.80	Rectangular	√3	1	1	0.46	0.46	∞
Integration Time	2.60	Rectangular	√3	1	1	1.50	1.50	∞
RF Ambient Noise	3.00	Rectangular	√3	1	1	1.73	1.73	∞
RF Ambient Reflections	3.00	Rectangular	√3	1	1	1.73	1.73	∞
Probe Positioner	0.40	Rectangular	√3	1	1	0.23	0.23	∞
Probe Positioning	2.90	Rectangular	√3	1	1	1.67	1.67	∞
Max. SAR Eval.	1.00	Rectangular	√3	1	1	0.58	0.58	∞
Dipole Related								
Dipole Axis to Liquid Distance	2.00	Rectangular	√3	1	1	1.15	1.15	145
Input Power Drift	5.00	Rectangular	√3	1	1	2.89	2.89	∞
Phantom and Tissue parameters								
Phantom Uncertainty	4.00	Rectangular	√3	1	1	2.31	2.31	∞
Liquid Conductivity (target)	5.00	Rectangular	√3	0.64	0.43	1.85	1.24	∞
Liquid Conductivity (measurement)	3.50	Normal	1	0.64	0.43	2.24	1.51	∞
Liquid Permittivity (target)	5.00	Rectangular	√3	0.6	0.49	1.73	1.41	∞
Liquid Permittivity (measurement)	3.93	Normal	1	0.6	0.49	2.36	1.93	∞
Combined Standard Uncertainty						10.03	9.65	
Coverage Factor for 95%						Kp=2		
Expanded Uncertainty (K=2)						20.07	19.31	

NOTE: About the system validation uncertainty assessment, please reference the section 7.



7. MEASUREMENT SAR PROCEDURE UNCERTAINTIES

The assessment of spatial peak SAR of the hand held devices is according to IEEE 1528 / EN 62209-1. All testing situation shall be met below these requirements.

- The system is used by an experienced engineer who follows the manual and the guidelines taught during the training provided by SPEAG.
- The probe has been calibrated within the requested period and the stated uncertainty for the relevant frequency bands does not exceed 4.8% (k=1).
- The validation dipole has been calibrated within the requested period and the system performance check has been successful.
- The DAE unit has been calibrated within the within the requested period.
- The minimum distance between the probe sensor and inner phantom shell is selected to be between 4 and 5mm.
- The operational mode of the DUT is CW, CDMA, FDMA or TDMA (GSM, DCS, PCS, IS136 and PDC) and the measurement/integration time per point is >500 ms.
- The dielectric parameters of the liquid have been assessed using Agilent 85070D dielectric probe kit or a more accurate method.
- The dielectric parameters are within 5% of the target values.
- The DUT has been positioned as described in section 3.

7.1. PROBE CALIBRATION UNCERTAINTY

SPEAG conducts the probe calibration in compliance with international and national standards (e.g. IEEE 1528, EN 62209-1, IEC 62209, etc.) under ISO17025. The uncertainties are stated on the calibration certificate. For the most relevant frequency bands, these values do not exceed 4.8% (k=1). If evaluations of other bands are performed for which the uncertainty exceeds these values, the uncertainty tables given in the summary have to be revised accordingly.

7.2. ISOTROPY UNCERTAINTY

The axial isotropy tolerance accounts for probe rotation around its axis while the hemispherical isotropy error includes all probe orientations and field polarizations. These parameters are assessed by SPEAG during initial calibration. In 2001, SPEAG further tightened its quality controls and warrants that the maximal deviation from axial isotropy is $\pm 0.20\text{dB}$, while the maximum deviation of hemispherical isotropy is $\pm 0.40\text{dB}$, corresponding to $\pm 4.7\%$ and $\pm 9.6\%$, respectively. A weighting factor of c_p equal to 0.5 can be applied, since the axis of the probe deviates less than 30 degrees from the normal surface orientation.

7.3. BOUNDARY EFFECT UNCERTAINTY

The effect can be estimated according to the following error approximation formula

$$SAR_{tolerance} [\%] = SAR_{be} [\%] \times \frac{(d_{be} + d_{step})^2}{2d_{step}} e^{-\frac{d_{be}}{\delta/2}}$$

$$d_{be} + d_{step} < 10\text{mm}$$

The parameter d_{be} is the distance in mm between the surface and the closest measurement point used in the averaging process; d_{step} is the separation distance in mm between the first and second measurement points; δ is the minimum penetration depth in mm within the head tissue equivalent liquids (i.e., $\delta = 13.95\text{mm}$ at 3GHz); SAR_{be} is the deviation between the measured SAR value at the distance d_{be} from the boundary and the wave-guide analytical value SAR_{ref} . DASY4 applies a boundary effect compensation algorithm according to IEEE 1528, which is possible since the axis of the probe never deviates more than 30 degrees from the normal surface orientation. $SAR_{be}[\%]$ is assessed during the calibration process and SPEAG warrants that the uncertainty at distances larger than 4mm is always less than 1%. In summary, the worst case boundary effect SAR tolerance[%] for scanning distances larger than 4mm is $< \pm 0.8\%$.

7.4. PROBE LINEARITY UNCERTAINTY

Field probe linearity uncertainty includes errors from the assessment and compensation of the diode compression effects for CW and pulsed signals with known duty cycles. This error is assessed using the procedure described in IEEE 1528 / EN 62209-1. For SPEAG field probes, the measured difference between CW and pulsed signals, with pulse frequencies between 10Hz and 1kHz and duty cycles between 1 and 100, is $< \pm 0.20\text{dB}$ ($< \pm 4.7\%$).

7.5. READOUT ELECTRONICS UNCERTAINTY

All uncertainties related to the probe readout electronics (DAE unit), including the gain and linearity of the instrumentation amplifier, its loading effect on the probe, and accuracy of the signal conversion algorithm, have been assessed accordingly to IEEE 1528 / EN 62209-1. The combination (root-sum-square RSS method) of these components results in an overall maximum error of $\pm 1.0\%$.

7.6. RESPONSE TIME UNCERTAINTY

The time response of the field probes is assessed by exposing the probe to a well-controlled electric field producing SAR larger than 2.0W/kg at the tissue medium surface. The signal response time is evaluated as the time required by the system to reach 90% of the expected final value after an on/of switch of the power source. Analytically, it can be expressed as:

$$SAR_{tolerance} [\%] = 100 \times \left(\frac{T_m}{T_m + \tau e^{-T_m/\tau} - \tau} - 1 \right)$$

where T_m is 500 ms, i.e., the time between measurement samples, and τ the time constant. The response time τ of SPEAG's probes is $< 5\text{ms}$. In the current implementation, DASY4 waits longer than 100 ms after having reached the grid point before starting a measurement, i.e., the response time uncertainty is negligible.

7.7. INTEGRATION TIME UNCERTAINTY

If the device under test does not emit a CW signal, the integration time applied to measure the electric field at a specific point may introduce additional uncertainties due to the discretization and can be assessed as follows

$$SAR_{tolerance} [\%] = 100 \times \sum_{all\ sub-frames} \frac{t_{frame}}{t_{integration}} \frac{slot_{idle}}{slot_{total}}$$

The tolerances for the different systems are given in Table 7.1, whereby the worst-case SAR_{tolerance} is 2.6%.

System	SAR _{tolerance} %
CW	0
CDMA*	0
WCDMA*	0
FDMA	0
IS-136	2.6
PDC	2.6
GSM/DCS/PCS	1.7
DECT	1.9
Worst-Case	2.6

TABLE 7.1

7.8. PROBE POSITIONER MECHANICAL TOLERANCE

The mechanical tolerance of the field probe positioner can introduce probe positioning uncertainties. The resulting SAR uncertainty is assessed by comparing the SAR obtained according to the specifications of the probe positioner with respect to the actual position defined by the geometric center of the probe sensors. The tolerance is determined as:

$$SAR_{tolerance} [\%] = 100 \times \frac{d_{ph}}{\delta/2}$$

The specified repeatability of the RX robot family used in DASY4 systems is $\pm 25\mu\text{m}$. The absolute accuracy for short distance movements is better than $\pm 0.1\text{mm}$, i.e., the $SAR_{tolerance}[\%]$ is better than 1.5% (rectangular).

7.9. PROBE POSITIONING

The probe positioning procedures affect the tolerance of the separation distance between the probe tip and the phantom surface as:

$$SAR_{tolerance} [\%] = 100 \times \frac{d_{ph}}{\delta/2}$$

where d_{ph} is the maximum deviation of the distance between the probe tip and the phantom surface. The optical surface detection has a precision of better than 0.2mm, resulting in an $SAR_{tolerance}[\%]$ of <2.9% (rectangular distribution). Since the mechanical detection provides better accuracy, 2.9% is a worst-case figure for DASY4 system.



7.10. PHANTOM UNCERTAINTY

The SAR measurement uncertainty due to SPEAG phantom shell production tolerances has been evaluated using

$$SAR_{tolerance} [\%] \cong 100 \times \frac{2d}{a}, \quad d \ll a$$

For a maximum deviation d of the inner and outer shell of the phantom from that specified in the CAD file of $\pm 0.2\text{mm}$, and a 10mm spacing a between source and tissue liquid, the calculated phantom uncertainty is $\pm 4.0\%$.



7.11. DASY4 UNCERTAINTY BUDGET

Error Description	Tolerance (±%)	Probability Distribution	Divisor	(C _i)		Standard Uncertainty (±%)		(v _i)
				(1g)	(10g)	(1g)	(10g)	
Measurement Equipment								
Probe Calibration	5.50	Normal	1	1	1	5.50	5.50	∞
Axial Isotropy	4.70	Rectangular	√3	0.7	0.7	1.90	1.90	∞
Hemispherical Isotropy	9.60	Rectangular	√3	0.7	0.7	3.88	3.88	∞
Boundary effects	1.00	Rectangular	√3	1	1	0.58	0.58	∞
Linearity	4.70	Rectangular	√3	1	1	2.71	2.71	∞
System Detection Limits	1.00	Rectangular	√3	1	1	0.58	0.58	∞
Readout Electronics	0.30	Normal	1	1	1	0.30	0.30	∞
Response Time	0.80	Rectangular	√3	1	1	0.46	0.46	∞
Integration Time	2.60	Rectangular	√3	1	1	1.50	1.50	∞
RF Ambient Noise	3.00	Rectangular	√3	1	1	1.73	1.73	∞
RF Ambient Reflections	3.00	Rectangular	√3	1	1	1.73	1.73	∞
Probe Positioner	0.40	Rectangular	√3	1	1	0.23	0.23	∞
Probe Positioning	2.90	Rectangular	√3	1	1	1.67	1.67	∞
Max. SAR Eval.	1.00	Rectangular	√3	1	1	0.58	0.58	∞
Test Sample Related								
Device Positioning	0.69	Normal	1	1	1	0.69	0.69	10
Device Holder	3.60	Normal	1	1	1	3.60	3.60	5
Power Drift	5.00	Rectangular	√3	1	1	2.89	2.89	∞
Phantom and Tissue parameters								
Phantom Uncertainty	4.00	Rectangular	√3	1	1	2.31	2.31	∞
Liquid Conductivity (target)	5.00	Rectangular	√3	0.64	0.43	1.85	1.24	∞
Liquid Conductivity (measurement)	3.50	Normal	1	0.64	0.43	2.24	1.51	∞
Liquid Permittivity (target)	5.00	Rectangular	√3	0.6	0.49	1.73	1.41	∞
Liquid Permittivity (measurement)	3.93	Normal	1	0.6	0.49	2.36	1.93	∞
Combined Standard Uncertainty						10.62	10.26	
Coverage Factor for 95%						Kp=2		
Expanded Uncertainty (K=2)						21.24	20.52	

TABLE 7.2

The table 7.2: Worst-Case uncertainty budget for DASY4 assessed according to IEEE 1528. The budget is valid for the frequency range 300MHz ~ 3GHz and represents a worst-case analysis. For specific tests and configurations, the uncertainty could be considerable smaller.



A D T

8. INFORMATION ON THE TESTING LABORATORIES

We, Bureau Veritas Consumer Products Services (H.K.) Ltd., Taoyuan Branch, were founded in 1988 to provide our best service in EMC, Radio, Telecom and Safety consultation. Our laboratories are accredited and approved by the following approval agencies according to ISO/IEC 17025.

USA	FCC, NVLAP
GERMANY	TUV Rheinland
JAPAN	VCCI
NORWAY	NEMKO
CANADA	INDUSTRY CANADA, CSA
R.O.C.	TAF, BSMI, NCC
NETHERLANDS	Telefication
SINGAPORE	GOST-ASIA (MOU)
RUSSIA	CERTIS (MOU)

Copies of accreditation certificates of our laboratories obtained from approval agencies can be downloaded from our web site:

www.adt.com.tw/index.5/phtml. If you have any comments, please feel free to contact us at the following:

Linko EMC/RF Lab:

Tel: 886-2-26052180

Fax: 886-2-26051924

Hsin Chu EMC/RF Lab:

Tel: 886-3-5935343

Fax: 886-3-5935342

Hwa Ya EMC/RF/Safety/Telecom Lab:

Tel: 886-3-3183232

Fax: 886-3-3185050

Web Site: www.adt.com.tw

The address and road map of all our labs can be found in our web site also.

---END---

APPENDIX A: TEST DATA

Liquid Level Photo

Tissue HSL835MHz D=150mm

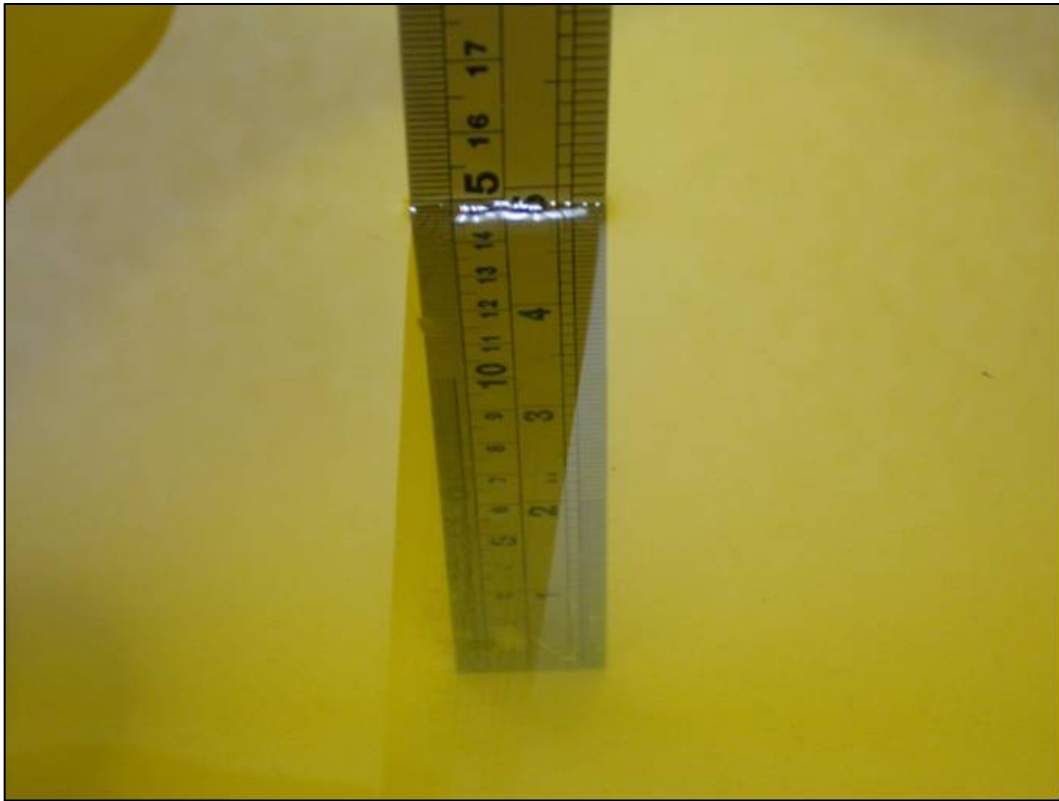

Tissue MSL835MHz D=151mm

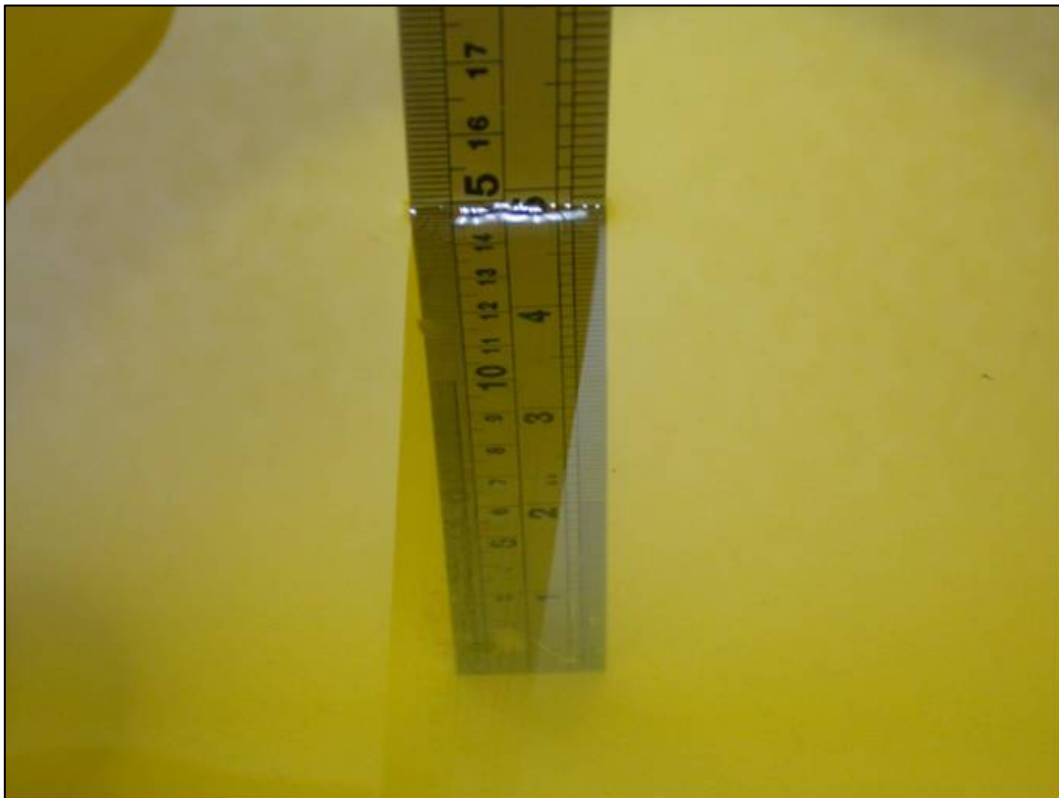

Tissue HSL1900MHz D=150mm



Tissue MSL1900MHz D=155mm



Test Laboratory: Bureau Veritas ADT

M01-Right Head-Cheek-CDMA850-Ch384

DUT: Pocket PC Phone ; Type: RHOD500

Communication System: CDMA ; Frequency: 836.5 MHz ; Duty Cycle: 1:1

Medium: HSL835 Medium parameters used: $f = 836.5$ MHz; $\sigma = 0.9$ mho/m; $\epsilon_r = 42.9$; $\rho = 1000$ kg/m³

Phantom section: Right Section ; DUT test position : Cheek ; Modulation type: OQPSK

DASY4 Configuration:

- Probe: EX3DV3 - SN3504 ; ConvF(9.57, 9.57, 9.57) ; Calibrated: 2009/1/21

- Sensor-Surface: 3mm (Mechanical Surface Detection)

- Electronics: DAE3 Sn510 ; Calibrated: 2009/1/21

- Phantom: SAM 12; Type: SAM V4.0; Serial: TP 1202

- Measurement SW: DASY4, V4.7 Build 80; Postprocessing SW: SEMCAD, V1.8 Build 186

Touch position - Mid Channel 384/Area Scan (6x10x1): Measurement grid: dx=15mm, dy=15mm

Maximum value of SAR (measured) = 0.732 mW/g

Touch position - Mid Channel 384/Zoom Scan (7x7x7) (7x7x7)/Cube 0: Measurement grid: dx=5mm, dy=5mm, dz=5mm

Reference Value = 21.9 V/m

Peak SAR (extrapolated) = 0.879 W/kg

SAR(1 g) = 0.606 mW/g; SAR(10 g) = 0.452 mW/g

Maximum value of SAR (measured) = 0.718 mW/g

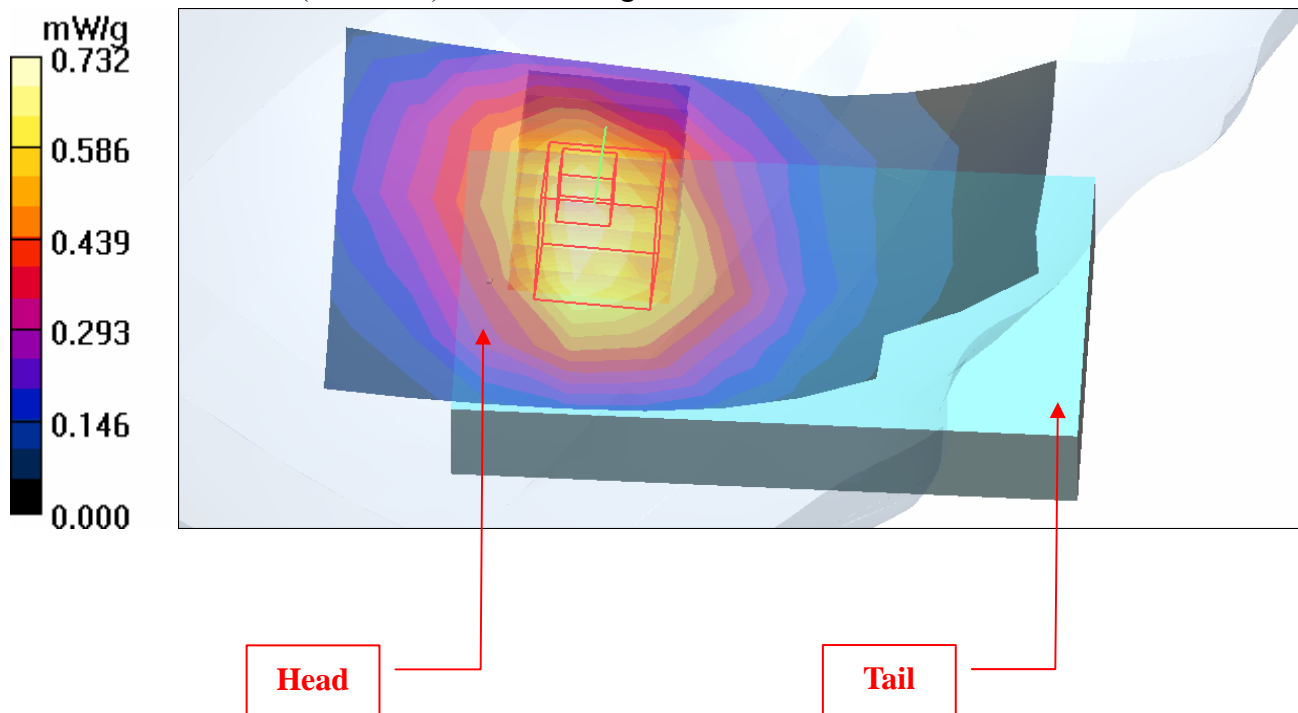

Test Laboratory: Bureau Veritas ADT

M02-Right Head-Tilt-CDMA850-Ch384

DUT: Pocket PC Phone ; Type: RHOD500

Communication System: CDMA ; Frequency: 836.5 MHz; Duty Cycle: 1:1

Medium: HSL835 Medium parameters used: $f = 836.5$ MHz; $\sigma = 0.9$ mho/m; $\epsilon_r = 42.9$; $\rho = 1000$ kg/m³

Phantom section: Right Section ; DUT test position : Tilt ; Modulation type: OQPSK

DASY4 Configuration:

- Probe: EX3DV3 - SN3504 ; ConvF(9.57, 9.57, 9.57) ; Calibrated: 2009/1/21
- Sensor-Surface: 3mm (Mechanical Surface Detection)
- Electronics: DAE3 Sn510 ; Calibrated: 2009/1/21
- Phantom: SAM 12; Type: SAM V4.0; Serial: TP 1202
- Measurement SW: DASY4, V4.7 Build 80; Postprocessing SW: SEMCAD, V1.8 Build 186

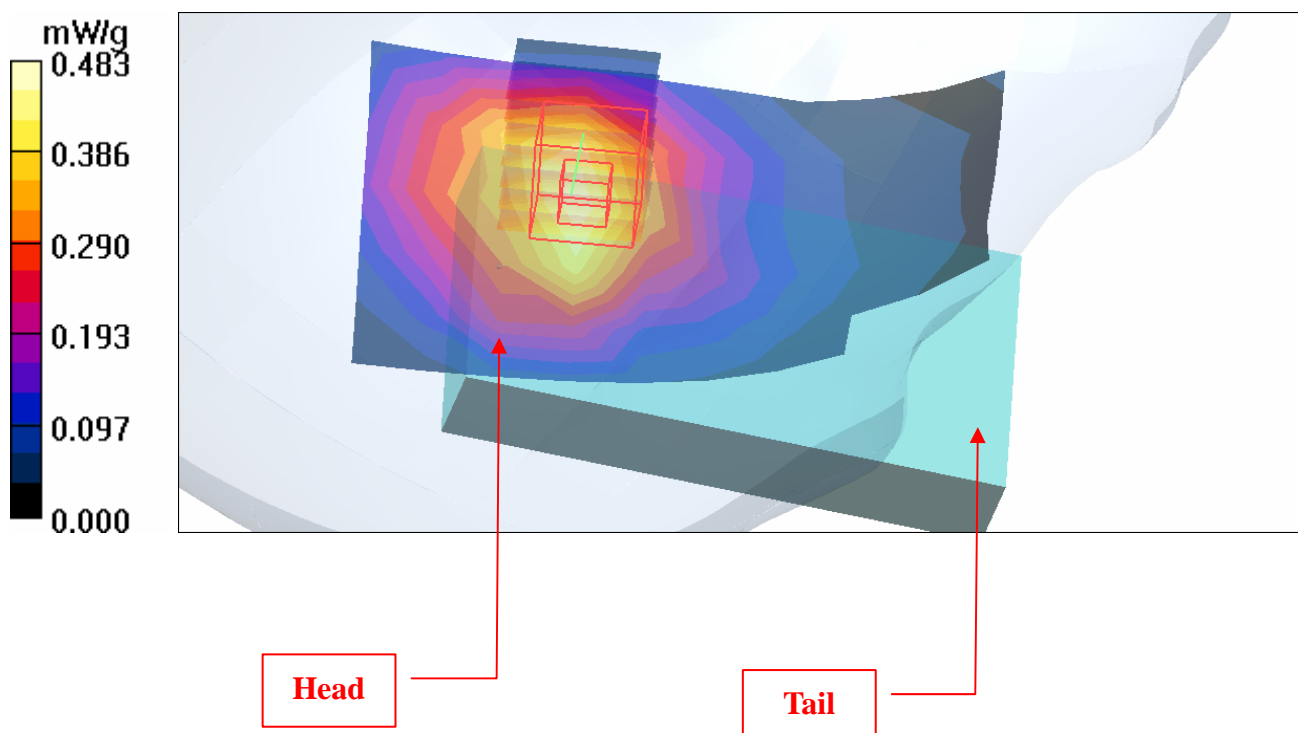
Tilt position - Mid Channel 384/Area Scan (6x10x1): Measurement grid: dx=15mm, dy=15mm
Maximum value of SAR (measured) = 0.483 mW/g**Tilt position - Mid Channel 384/Zoom Scan (7x7x7) (7x7x7)/Cube 0:** Measurement grid:
dx=5mm, dy=5mm, dz=5mm
Reference Value = 18.5 V/m
Peak SAR (extrapolated) = 0.586 W/kg
SAR(1 g) = 0.416 mW/g; SAR(10 g) = 0.288 mW/g
Maximum value of SAR (measured) = 0.476 mW/g

Test Laboratory: Bureau Veritas ADT

M03-Left Head-Cheek-CDMA850-Ch384

DUT: Pocket PC Phone ; Type: RHOD500

Communication System: CDMA ; Frequency: 836.5 MHz ; Duty Cycle: 1:1

Medium: HSL835 Medium parameters used: $f = 836.5$ MHz; $\sigma = 0.9$ mho/m; $\epsilon_r = 42.9$; $\rho = 1000$ kg/m³

Phantom section: Left Section ; DUT test position : Cheek ; Modulation type: OQPSK

DASY4 Configuration:

- Probe: EX3DV3 - SN3504 ; ConvF(9.57, 9.57, 9.57) ; Calibrated: 2009/1/21
- Sensor-Surface: 3mm (Mechanical Surface Detection)
- Electronics: DAE3 Sn510 ; Calibrated: 2009/1/21
- Phantom: SAM 12; Type: SAM V4.0; Serial: TP 1202
- Measurement SW: DASY4, V4.7 Build 80; Postprocessing SW: SEMCAD, V1.8 Build 186

Touch position - Mid Channel 384/Area Scan (6x10x1): Measurement grid: dx=15mm, dy=15mm

Maximum value of SAR (measured) = 0.818 mW/g

Touch position - Mid Channel 384/Zoom Scan (7x7x7) (7x7x7)/Cube 0: Measurement grid: dx=5mm, dy=5mm, dz=5mm

Reference Value = 20.9 V/m

Peak SAR (extrapolated) = 1.04 W/kg

SAR(1 g) = 0.691 mW/g; SAR(10 g) = 0.469 mW/g

Maximum value of SAR (measured) = 0.791 mW/g

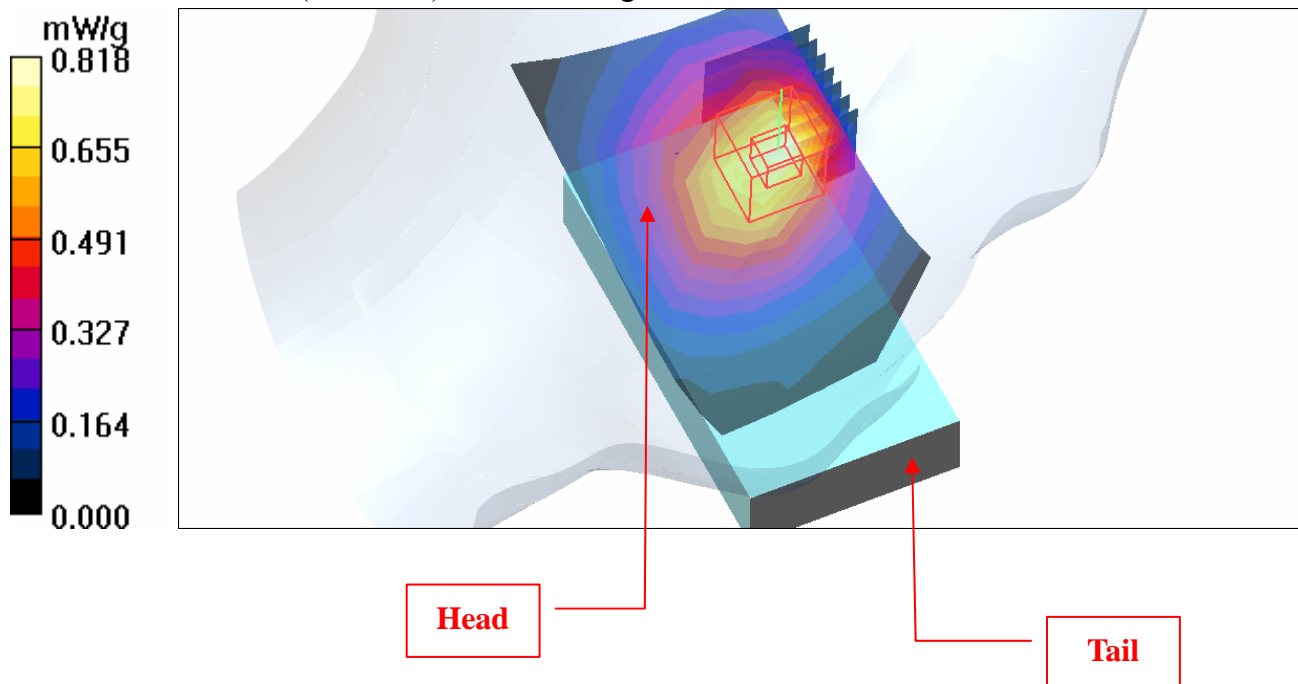

Test Laboratory: Bureau Veritas ADT

M04-Left Head-Tilt-CDMA850-Ch384

DUT: Pocket PC Phone ; Type: RHOD500

Communication System: CDMA ; Frequency: 836.5 MHz; Duty Cycle: 1:1

Medium: HSL835 Medium parameters used: $f = 836.5$ MHz; $\sigma = 0.9$ mho/m; $\epsilon_r = 42.9$; $\rho = 1000$ kg/m³

Phantom section: Left Section ; DUT test position : Tilt ; Modulation type: OQPSK

DASY4 Configuration:

- Probe: EX3DV3 - SN3504 ; ConvF(9.57, 9.57, 9.57) ; Calibrated: 2009/1/21
- Sensor-Surface: 3mm (Mechanical Surface Detection)
- Electronics: DAE3 Sn510 ; Calibrated: 2009/1/21
- Phantom: SAM 12; Type: SAM V4.0; Serial: TP 1202
- Measurement SW: DASY4, V4.7 Build 80; Postprocessing SW: SEMCAD, V1.8 Build 186

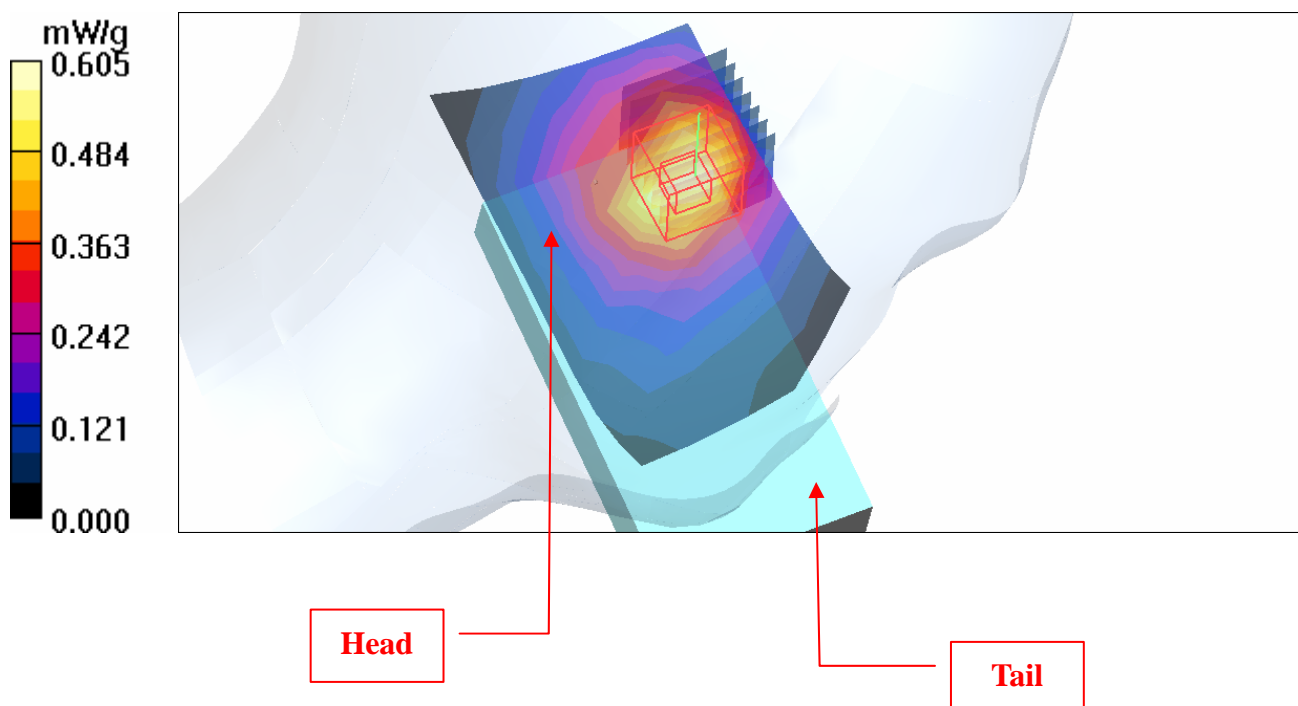
Tilt position - Mid Channel 384/Area Scan (6x10x1): Measurement grid: dx=15mm, dy=15mm
Maximum value of SAR (measured) = 0.605 mW/g**Tilt position - Mid Channel 384/Zoom Scan (7x7x7) (7x7x7)/Cube 0:** Measurement grid:
dx=5mm, dy=5mm, dz=5mm
Reference Value = 19.1 V/m
Peak SAR (extrapolated) = 0.780 W/kg
SAR(1 g) = 0.515 mW/g; SAR(10 g) = 0.338 mW/g
Maximum value of SAR (measured) = 0.597 mW/g

Test Laboratory: Bureau Veritas ADT

M05-Body-CDMA850 SO32-Ch384 / Slider-off / LCD DOWN

DUT: Pocket PC Phone ; Type: RHOD500

Communication System: CDMA ; Frequency: 836.5 MHz ; Duty Cycle: 1:1
 Medium: MSL835 Medium parameters used: $f = 836.5 \text{ MHz}$; $\sigma = 0.98 \text{ mho/m}$; $\epsilon_r = 55.8$; $\rho = 1000 \text{ kg/m}^3$
 Phantom section: Flat Section ; DUT test position : Body ; Modulation Type: OQPSK
 Separation Distance : 15 mm (The bottom side of the EUT to the Phantom)

DASY4 Configuration:

- Probe: EX3DV3 - SN3504 ; ConvF(9.71, 9.71, 9.71) ; Calibrated: 2009/1/21
- Sensor-Surface: 3mm (Mechanical Surface Detection)
- Electronics: DAE3 Sn510 ; Calibrated: 2009/1/21
- Phantom: SAM 12 ; Type: SAM V4.0; Serial: TP 1202
- Measurement SW: DASY4, V4.7 Build 80 ; Postprocessing SW: SEMCAD, V1.8 Build 186

Mid Channel 384/Area Scan (6x10x1): Measurement grid: $dx=15\text{mm}$, $dy=15\text{mm}$

Maximum value of SAR (measured) = 0.442 mW/g

Mid Channel 384/Zoom Scan (7x7x7) (7x7x7)/Cube 0: Measurement grid: $dx=5\text{mm}$, $dy=5\text{mm}$, $dz=5\text{mm}$

Reference Value = 17.2 V/m

Peak SAR (extrapolated) = 0.604 W/kg

SAR(1 g) = 0.391 mW/g; SAR(10 g) = 0.254 mW/g

Maximum value of SAR (measured) = 0.489 mW/g

Mid Channel 384/Zoom Scan (7x7x7) (7x7x7)/Cube 1: Measurement grid: $dx=5\text{mm}$, $dy=5\text{mm}$, $dz=5\text{mm}$

Reference Value = 17.2 V/m

Peak SAR (extrapolated) = 0.609 W/kg

SAR(1 g) = 0.396 mW/g; SAR(10 g) = 0.256 mW/g

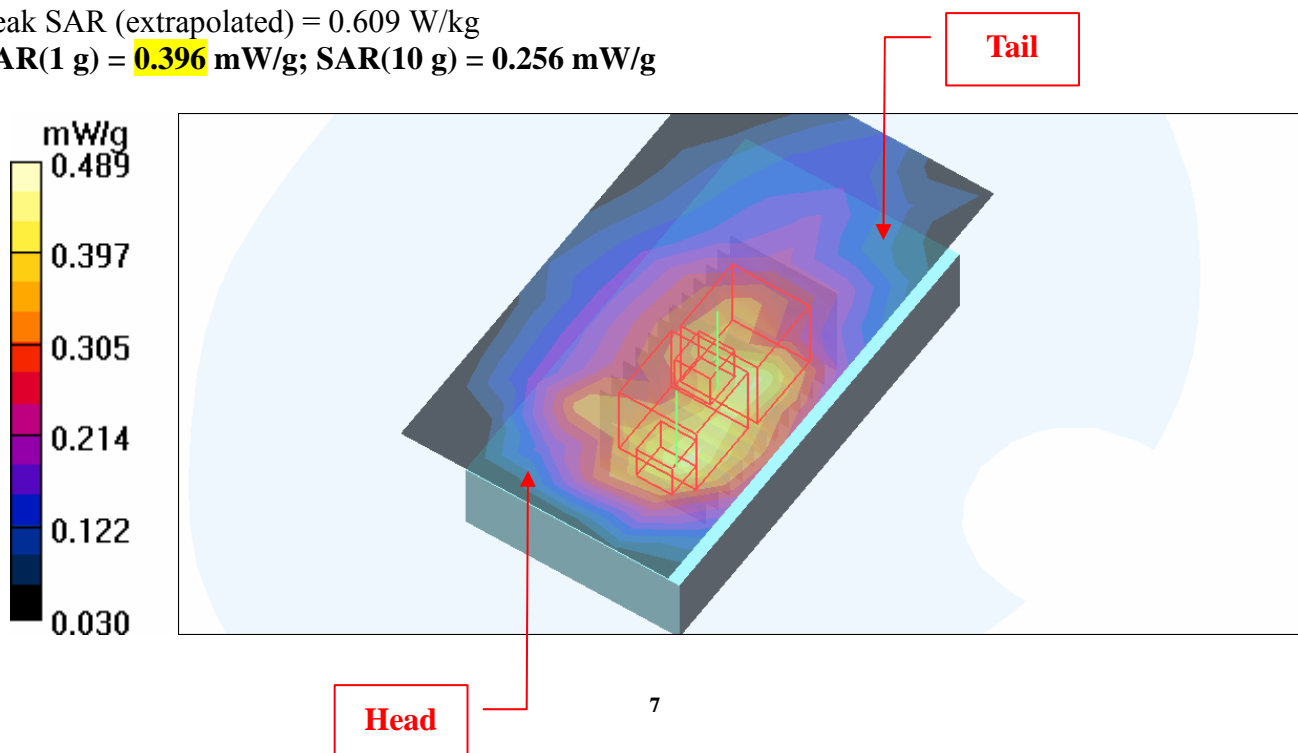

Test Laboratory: Bureau Veritas ADT

M06-Body-EVDO850 FTAP-Ch384 / Slider-off / LCD DOWN

DUT: Pocket PC Phone ; Type: RHOD500

Communication System: CDMA ; Frequency: 836.5 MHz ; Duty Cycle: 1:1

Medium: MSL835 Medium parameters used: $f = 836.5 \text{ MHz}$; $\sigma = 0.98 \text{ mho/m}$; $\epsilon_r = 55.8$; $\rho = 1000 \text{ kg/m}^3$

Phantom section: Flat Section ; DUT test position : Body ; Modulation Type: HPSK

Separation Distance : 15 mm (The bottom side of the EUT to the Phantom)

DASY4 Configuration:

- Probe: EX3DV3 - SN3504 ; ConvF(9.71, 9.71, 9.71) ; Calibrated: 2009/1/21
- Sensor-Surface: 3mm (Mechanical Surface Detection)
- Electronics: DAE3 Sn510 ; Calibrated: 2009/1/21
- Phantom: SAM 12 ; Type: SAM V4.0; Serial: TP 1202
- Measurement SW: DASY4, V4.7 Build 80 ; Postprocessing SW: SEMCAD, V1.8 Build 186

Mid Channel 384/Area Scan (6x10x1): Measurement grid: $dx=15\text{mm}$, $dy=15\text{mm}$

Maximum value of SAR (measured) = 0.497 mW/g

Mid Channel 384/Zoom Scan (7x7x7) (7x7x7)/Cube 0: Measurement grid: $dx=5\text{mm}$, $dy=5\text{mm}$, $dz=5\text{mm}$

Reference Value = 16.8 V/m

Peak SAR (extrapolated) = 0.585 W/kg

SAR(1 g) = 0.426 mW/g; SAR(10 g) = 0.317 mW/g

Maximum value of SAR (measured) = 0.509 mW/g

Mid Channel 384/Zoom Scan (7x7x7) (7x7x7)/Cube 1: Measurement grid: $dx=5\text{mm}$, $dy=5\text{mm}$, $dz=5\text{mm}$

Reference Value = 16.8 V/m

Peak SAR (extrapolated) = 0.513 W/kg

SAR(1 g) = 0.373 mW/g; SAR(10 g) = 0.253 mW/g

Maximum value of SAR (measured) = 0.463 mW/g

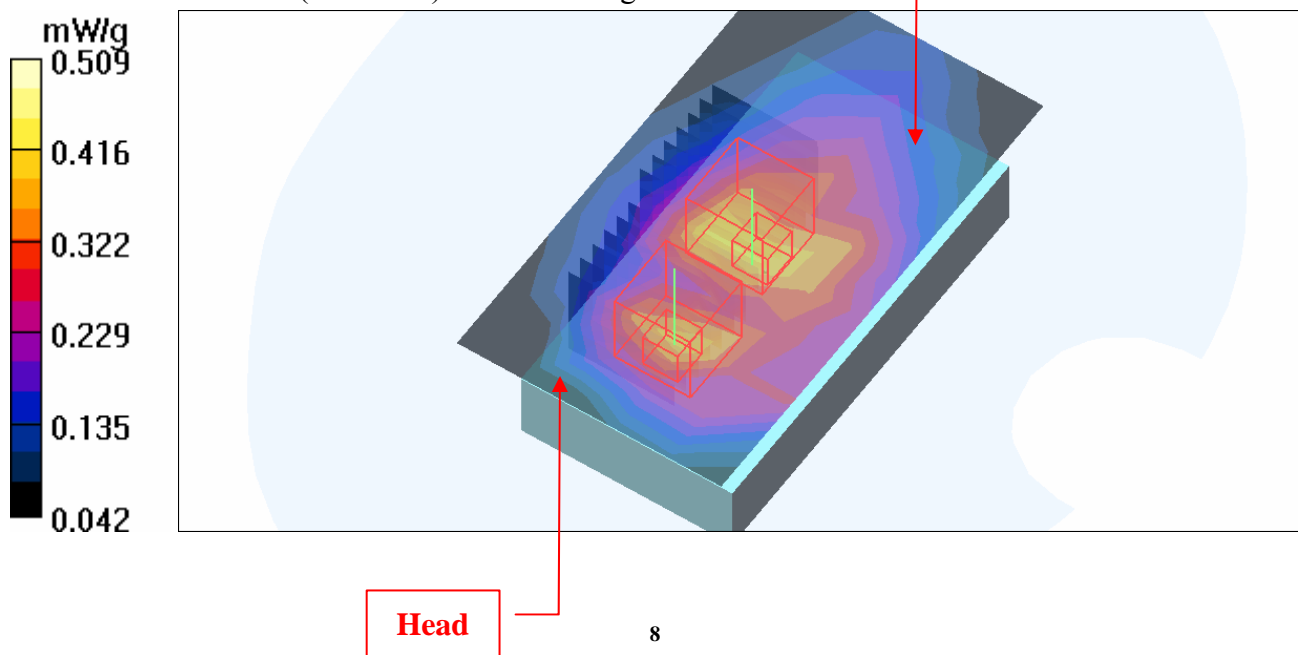

Test Laboratory: Bureau Veritas ADT

M07-Body-CDMA850 SO32-Ch384 / Slider-off / LCD UP**DUT: Pocket PC Phone ; Type: RHOD500**

Communication System: CDMA ; Frequency: 836.5 MHz ; Duty Cycle: 1:1

Medium: MSL835 Medium parameters used: $f = 836.5$ MHz; $\sigma = 0.98$ mho/m; $\epsilon_r = 55.8$; $\rho = 1000$ kg/m³

Phantom section: Flat Section ; DUT test position : Body ; Modulation Type: OQPSK

Separation Distance : 15 mm (The front side of the EUT to the Phantom)

DASY4 Configuration:

- Probe: EX3DV3 - SN3504 ; ConvF(9.71, 9.71, 9.71) ; Calibrated: 2009/1/21

- Sensor-Surface: 3mm (Mechanical Surface Detection)

- Electronics: DAE3 Sn510 ; Calibrated: 2009/1/21

- Phantom: SAM 12 ; Type: SAM V4.0; Serial: TP 1202

- Measurement SW: DASY4, V4.7 Build 80 ; Postprocessing SW: SEMCAD, V1.8 Build 186

Mid Channel 384/Area Scan (6x10x1): Measurement grid: dx=15mm, dy=15mm

Maximum value of SAR (measured) = 0.180 mW/g

Mid Channel 384/Zoom Scan (7x7x7) (7x7x7)/Cube 0: Measurement grid: dx=5mm, dy=5mm, dz=5mm

Reference Value = 11.8 V/m

Peak SAR (extrapolated) = 0.217 W/kg

SAR(1 g) = 0.167 mW/g; SAR(10 g) = 0.124 mW/g

Maximum value of SAR (measured) = 0.186 mW/g

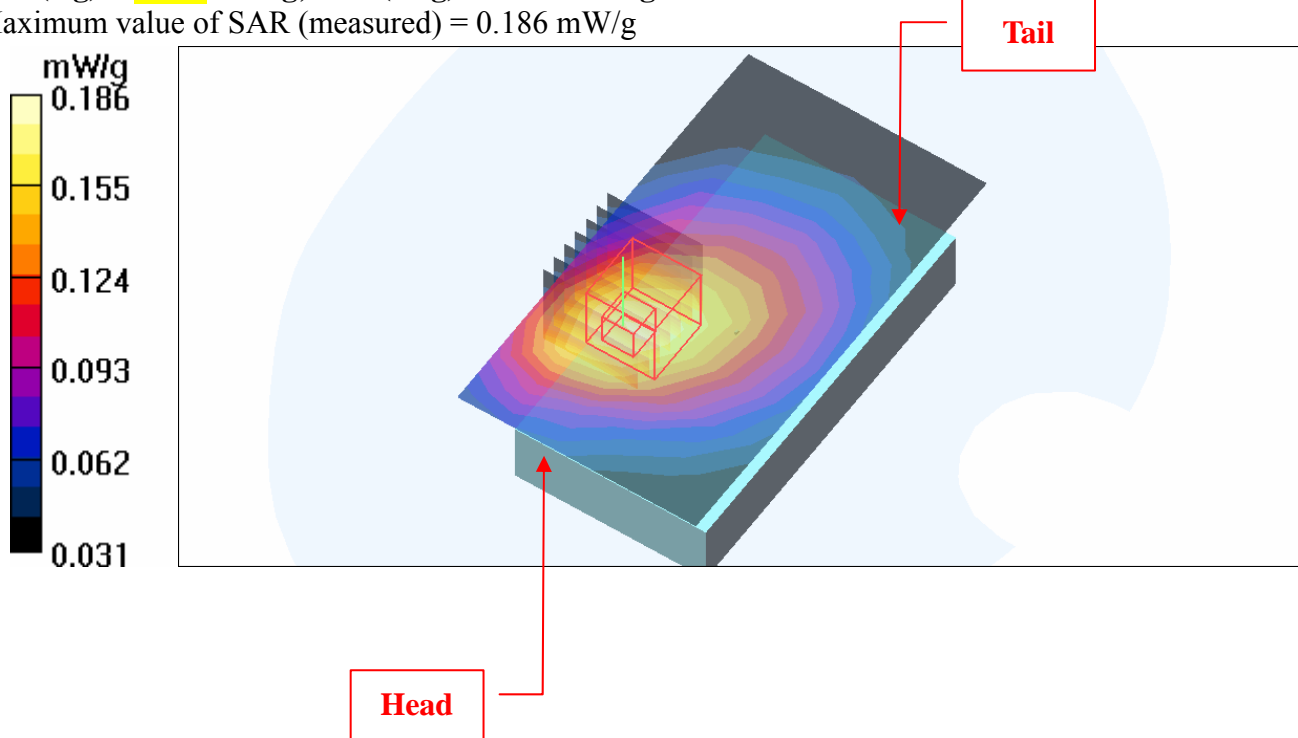

Test Laboratory: Bureau Veritas ADT

M08-Body-EVDO850 FTAP-Ch384 / Slider-off / LCD UP**DUT: Pocket PC Phone ; Type: RHOD500**

Communication System: CDMA ; Frequency: 836.5 MHz ; Duty Cycle: 1:1

Medium: MSL835 Medium parameters used: $f = 836.5$ MHz; $\sigma = 0.98$ mho/m; $\epsilon_r = 55.8$; $\rho = 1000$ kg/m³

Phantom section: Flat Section ; DUT test position : Body ; Modulation Type: HPSK

Separation Distance : 15 mm (The front side of the EUT to the Phantom)

DASY4 Configuration:

- Probe: EX3DV3 - SN3504 ; ConvF(9.71, 9.71, 9.71) ; Calibrated: 2009/1/21

- Sensor-Surface: 3mm (Mechanical Surface Detection)

- Electronics: DAE3 Sn510 ; Calibrated: 2009/1/21

- Phantom: SAM 12 ; Type: SAM V4.0; Serial: TP 1202

- Measurement SW: DASY4, V4.7 Build 80 ; Postprocessing SW: SEMCAD, V1.8 Build 186

Mid Channel 384/Area Scan (6x10x1): Measurement grid: dx=15mm, dy=15mm

Maximum value of SAR (measured) = 0.142 mW/g

Mid Channel 384/Zoom Scan (7x7x7) (7x7x7)/Cube 0: Measurement grid: dx=5mm, dy=5mm, dz=5mm

Reference Value = 9.00 V/m

Peak SAR (extrapolated) = 0.202 W/kg

SAR(1 g) = 0.152 mW/g; SAR(10 g) = 0.104 mW/g

Maximum value of SAR (measured) = 0.170 mW/g

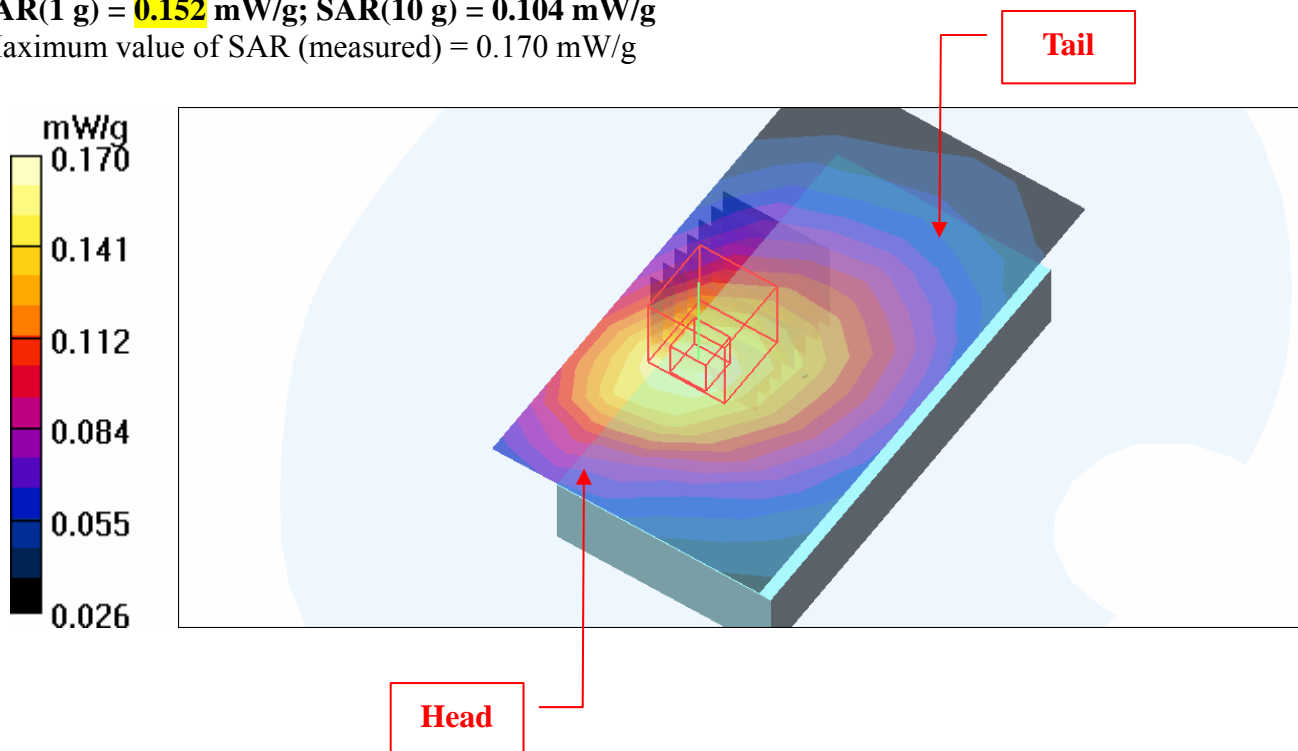

Test Laboratory: Bureau Veritas ADT

M09-Body-CDMA850 SO32-Ch384 / Slider-on / LCD DOWN

DUT: Pocket PC Phone ; Type: RHOD500

Communication System: CDMA ; Frequency: 836.5 MHz ; Duty Cycle: 1:1

Medium: MSL835 Medium parameters used: $f = 836.5 \text{ MHz}$; $\sigma = 0.98 \text{ mho/m}$; $\epsilon_r = 55.8$; $\rho = 1000 \text{ kg/m}^3$

Phantom section: Flat Section ; DUT test position : Body ; Modulation Type: OQPSK

Separation Distance : 15 mm (The bottom side of the EUT to the Phantom)

DASY4 Configuration:

- Probe: EX3DV3 - SN3504 ; ConvF(9.71, 9.71, 9.71) ; Calibrated: 2009/1/21
- Sensor-Surface: 3mm (Mechanical Surface Detection)
- Electronics: DAE3 Sn510 ; Calibrated: 2009/1/21
- Phantom: SAM 12 ; Type: SAM V4.0; Serial: TP 1202
- Measurement SW: DASY4, V4.7 Build 80 ; Postprocessing SW: SEMCAD, V1.8 Build 186

Mid Channel 384/Area Scan (9x10x1): Measurement grid: $dx=15\text{mm}$, $dy=15\text{mm}$

Maximum value of SAR (measured) = 0.660 mW/g

Mid Channel 384/Zoom Scan (7x7x7) (7x7x7)/Cube 0: Measurement grid: $dx=5\text{mm}$, $dy=5\text{mm}$, $dz=5\text{mm}$

Reference Value = 19.3 V/m

Peak SAR (extrapolated) = 0.947 W/kg

SAR(1 g) = 0.589 mW/g; SAR(10 g) = 0.383 mW/g

Maximum value of SAR (measured) = 0.704 mW/g

Mid Channel 384/Zoom Scan (7x7x7) (7x7x7)/Cube 1: Measurement grid: $dx=5\text{mm}$, $dy=5\text{mm}$, $dz=5\text{mm}$

Reference Value = 19.3 V/m

Peak SAR (extrapolated) = 0.655 W/kg

SAR(1 g) = 0.475 mW/g; SAR(10 g) = 0.319 mW/g

Maximum value of SAR (measured) = 0.585 mW/g

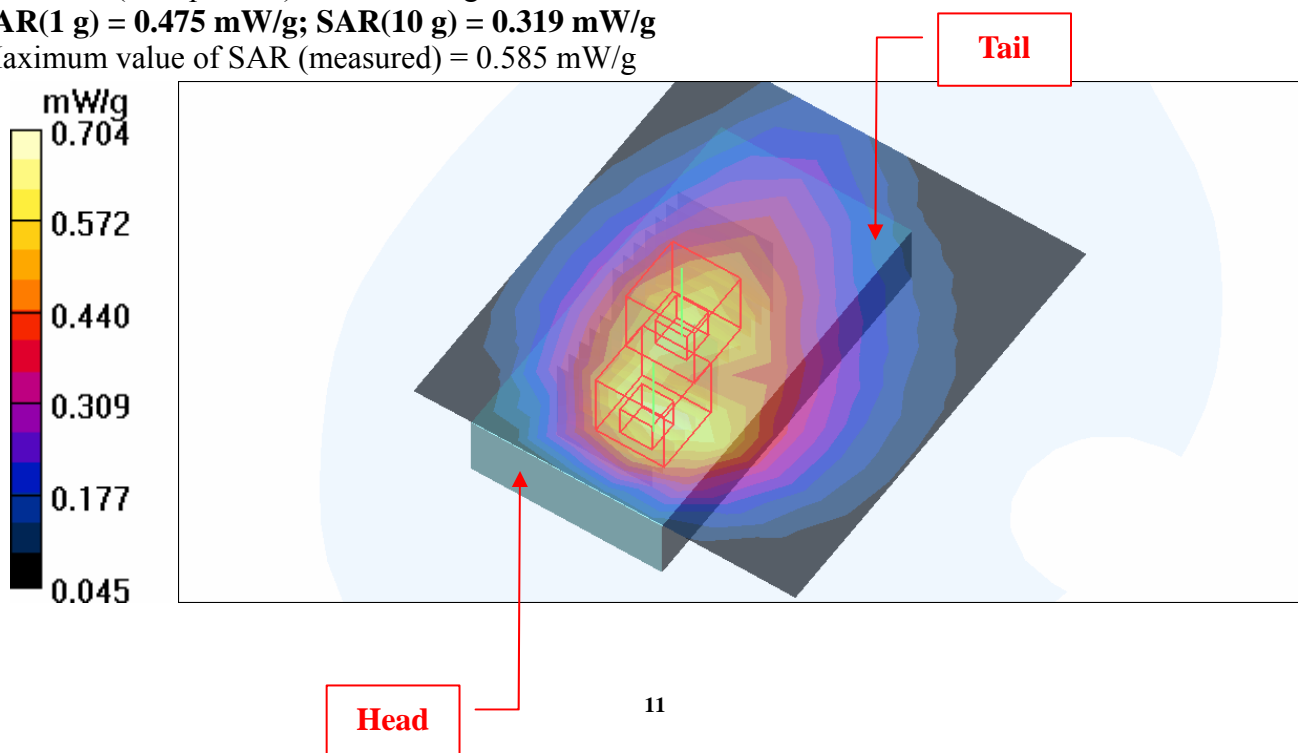

Test Laboratory: Bureau Veritas ADT

M10-Body-EVDO850 FTAP-Ch384 / Slider-on / LCD DOWN

DUT: Pocket PC Phone ; Type: RHOD500

Communication System: CDMA ; Frequency: 836.5 MHz ; Duty Cycle: 1:1

Medium: MSL835 Medium parameters used: $f = 836.5 \text{ MHz}$; $\sigma = 0.98 \text{ mho/m}$; $\epsilon_r = 55.8$; $\rho = 1000 \text{ kg/m}^3$

Phantom section: Flat Section ; DUT test position : Body ; Modulation Type: HPSK

Separation Distance : 15 mm (The bottom side of the EUT to the Phantom)

DASY4 Configuration:

- Probe: EX3DV3 - SN3504 ; ConvF(9.71, 9.71, 9.71) ; Calibrated: 2009/1/21

- Sensor-Surface: 3mm (Mechanical Surface Detection)

- Electronics: DAE3 Sn510 ; Calibrated: 2009/1/21

- Phantom: SAM 12 ; Type: SAM V4.0; Serial: TP 1202

- Measurement SW: DASY4, V4.7 Build 80 ; Postprocessing SW: SEMCAD, V1.8 Build 186

Mid Channel 384/Area Scan (9x10x1): Measurement grid: $dx=15\text{mm}$, $dy=15\text{mm}$

Maximum value of SAR (measured) = 0.572 mW/g

Mid Channel 384/Zoom Scan (7x7x7) (7x7x7)/Cube 0: Measurement grid: $dx=5\text{mm}$, $dy=5\text{mm}$, $dz=5\text{mm}$

Reference Value = 18.9 V/m

Peak SAR (extrapolated) = 0.973 W/kg

SAR(1 g) = 0.547 mW/g; SAR(10 g) = 0.357 mW/g

Maximum value of SAR (measured) = 0.663 mW/g

Mid Channel 384/Zoom Scan (7x7x7) (7x7x7)/Cube 1: Measurement grid: $dx=5\text{mm}$, $dy=5\text{mm}$, $dz=5\text{mm}$

Reference Value = 18.9 V/m

Peak SAR (extrapolated) = 0.634 W/kg

SAR(1 g) = 0.465 mW/g; SAR(10 g) = 0.316 mW/g

Maximum value of SAR (measured) = 0.534 mW/g

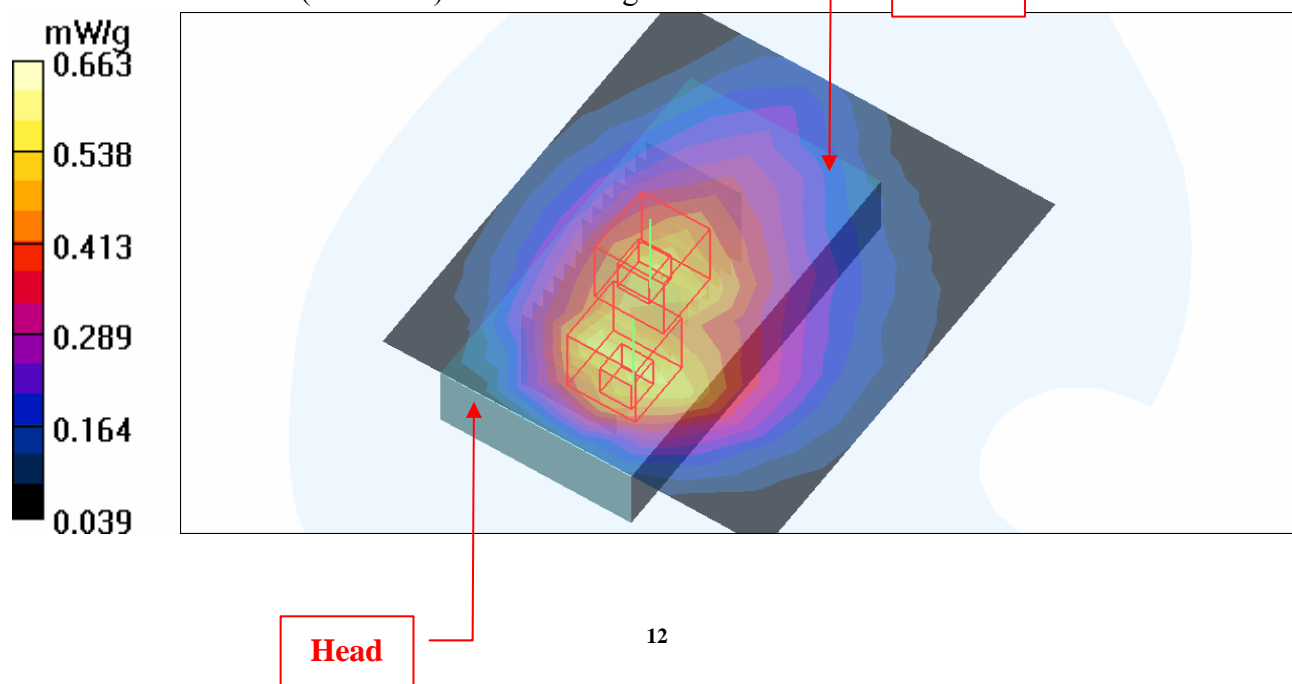

Test Laboratory: Bureau Veritas ADT

M11-Body-CDMA850 SO32-Ch384 / Slider-on / LCD UP

DUT: Pocket PC Phone ; Type: RHOD500

Communication System: CDMA ; Frequency: 836.5 MHz ; Duty Cycle: 1:1
Medium: MSL835 Medium parameters used: $f = 836.5$ MHz; $\sigma = 0.98$ mho/m; $\epsilon_r = 55.8$; $\rho = 1000$ kg/m³
Phantom section: Flat Section ; DUT test position : Body ; Modulation Type: OQPSK
Separation Distance : 15 mm (The front side of the EUT to the Phantom)

DASY4 Configuration:

- Probe: EX3DV3 - SN3504 ; ConvF(9.71, 9.71, 9.71) ; Calibrated: 2009/1/21
- Sensor-Surface: 3mm (Mechanical Surface Detection)
- Electronics: DAE3 Sn510 ; Calibrated: 2009/1/21
- Phantom: SAM 12 ; Type: SAM V4.0; Serial: TP 1202
- Measurement SW: DASY4, V4.7 Build 80 ; Postprocessing SW: SEMCAD, V1.8 Build 186

Mid Channel 384/Area Scan (9x10x1): Measurement grid: dx=15mm, dy=15mm
Maximum value of SAR (measured) = 0.283 mW/g

Mid Channel 384/Zoom Scan (7x7x7) (7x7x7)/Cube 0: Measurement grid: dx=5mm, dy=5mm, dz=5mm

Reference Value = 16.9 V/m

Peak SAR (extrapolated) = 0.325 W/kg

SAR(1 g) = **0.256** mW/g; SAR(10 g) = 0.198 mW/g

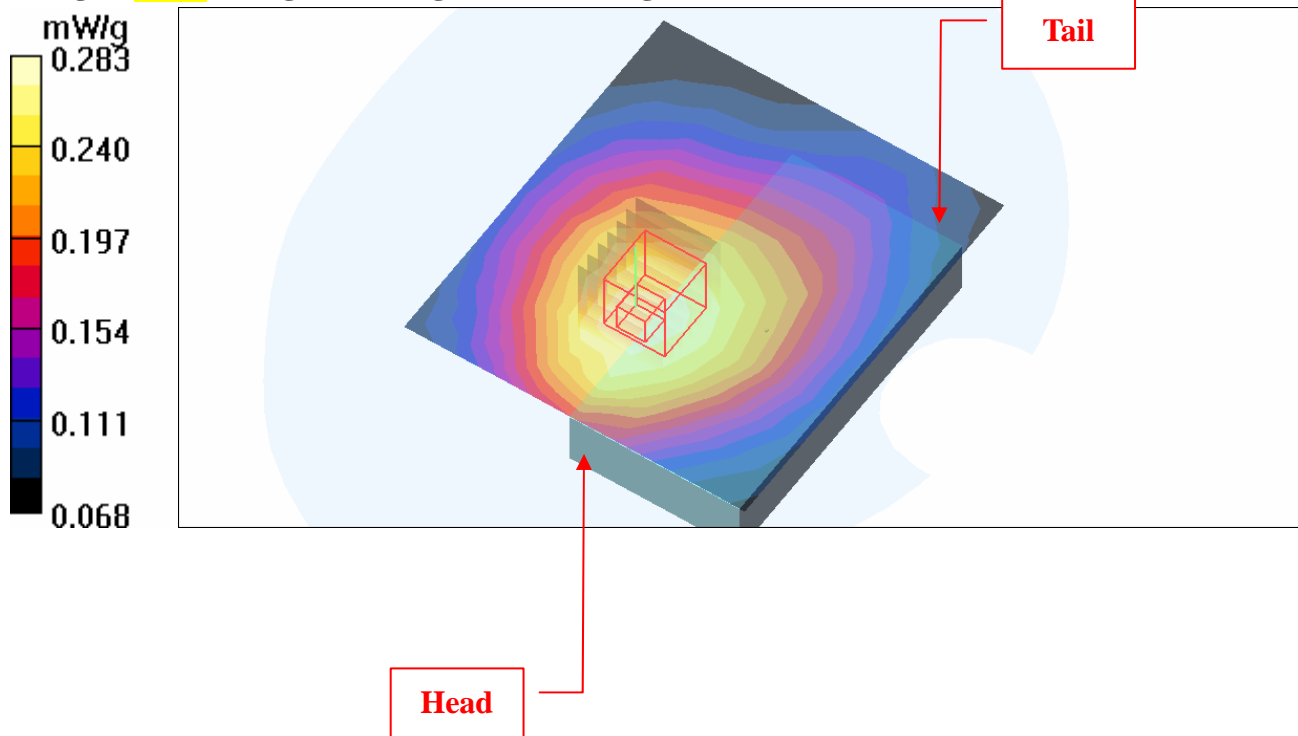

Test Laboratory: Bureau Veritas ADT

M12-Body-EVDO850 FTAP-Ch384 / Slider-on / LCD UP**DUT: Pocket PC Phone ; Type: RHOD500**

Communication System: CDMA ; Frequency: 836.5 MHz ; Duty Cycle: 1:1
Medium: MSL835 Medium parameters used: $f = 836.5$ MHz; $\sigma = 0.98$ mho/m; $\epsilon_r = 55.8$; $\rho = 1000$ kg/m³
Phantom section: Flat Section ; DUT test position : Body ; Modulation Type: HPSK
Separation Distance : 15 mm (The front side of the EUT to the Phantom)

DASY4 Configuration:

- Probe: EX3DV3 - SN3504 ; ConvF(9.71, 9.71, 9.71) ; Calibrated: 2009/1/21
- Sensor-Surface: 3mm (Mechanical Surface Detection)
- Electronics: DAE3 Sn510 ; Calibrated: 2009/1/21
- Phantom: SAM 12 ; Type: SAM V4.0; Serial: TP 1202
- Measurement SW: DASY4, V4.7 Build 80 ; Postprocessing SW: SEMCAD, V1.8 Build 186

Mid Channel 384/Area Scan (9x10x1): Measurement grid: dx=15mm, dy=15mm

Maximum value of SAR (measured) = 0.317 mW/g

Mid Channel 384/Zoom Scan (7x7x7) (7x7x7)/Cube 0: Measurement grid: dx=5mm, dy=5mm, dz=5mm

Reference Value = 16.4 V/m

Peak SAR (extrapolated) = 0.356 W/kg

SAR(1 g) = 0.285 mW/g; SAR(10 g) = 0.219 mW/g

Maximum value of SAR (measured) = 0.316 mW/g

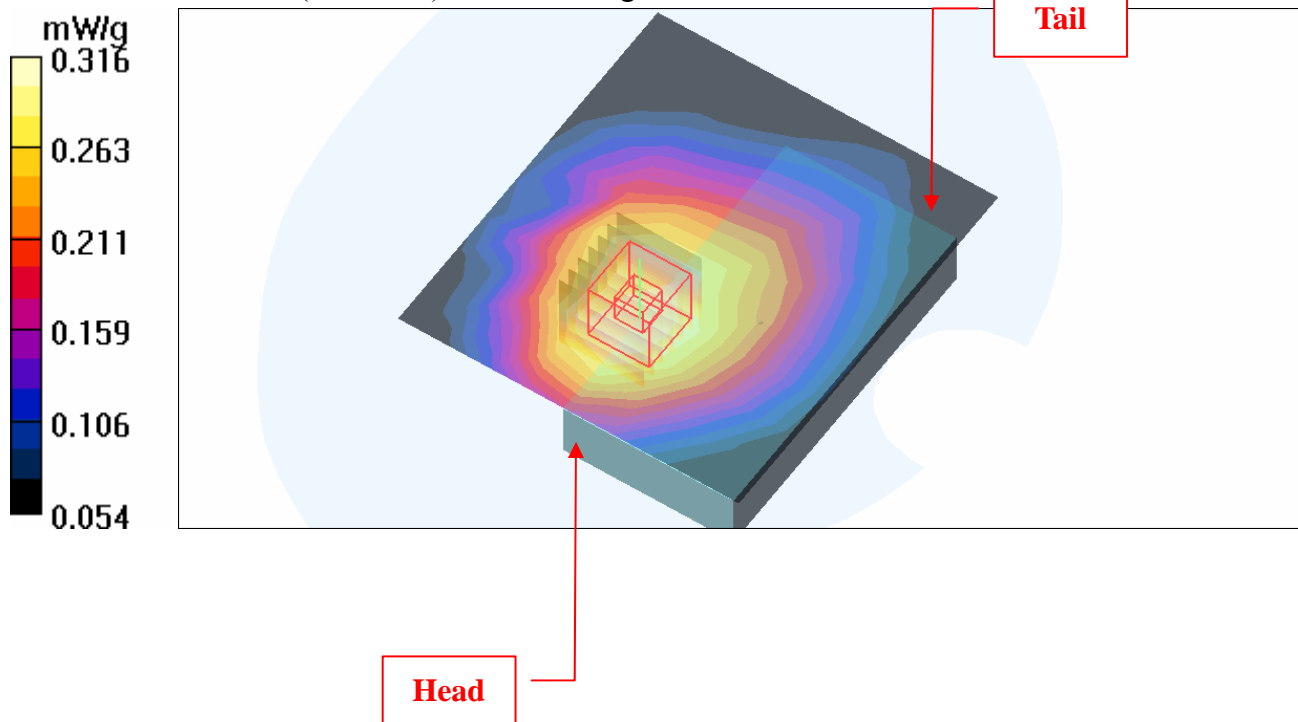

Test Laboratory: Bureau Veritas ADT

M13-Right Head-Cheek-CDMA1900-Ch25

DUT: Pocket PC Phone ; Type: RHOD500

Communication System: CDMA ; Frequency: 1851.25 MHz ; Duty Cycle: 1:1

Medium: HSL1900 Medium parameters used: $f = 1851.25$ MHz; $\sigma = 1.36$ mho/m; $\epsilon_r = 40.6$; $\rho = 1000$ kg/m³

Phantom section: Right Section ; DUT test position : Cheek ; Modulation type: OQPSK

DASY4 Configuration:

- Probe: EX3DV3 - SN3504 ; ConvF(8.08, 8.08, 8.08) ; Calibrated: 2009/1/21
- Sensor-Surface: 3mm (Mechanical Surface Detection)
- Electronics: DAE3 Sn510 ; Calibrated: 2009/1/21
- Phantom: SAM 12; Type: SAM V4.0; Serial: TP 1202
- Measurement SW: DASY4, V4.7 Build 80 ; Postprocessing SW: SEMCAD, V1.8 Build 186

Touch position - Low Channel 25/Area Scan (6x10x1): Measurement grid: $dx=15$ mm, $dy=15$ mm

Maximum value of SAR (measured) = 0.964 mW/g

Touch position - Low Channel 25/Zoom Scan (7x7x7) (7x7x7)/Cube 0: Measurement grid: $dx=5$ mm, $dy=5$ mm, $dz=5$ mm

Reference Value = 21.1 V/m

Peak SAR (extrapolated) = 1.30 W/kg

SAR(1 g) = 0.849 mW/g; SAR(10 g) = 0.518 mW/g

Maximum value of SAR (measured) = 1.00 mW/g

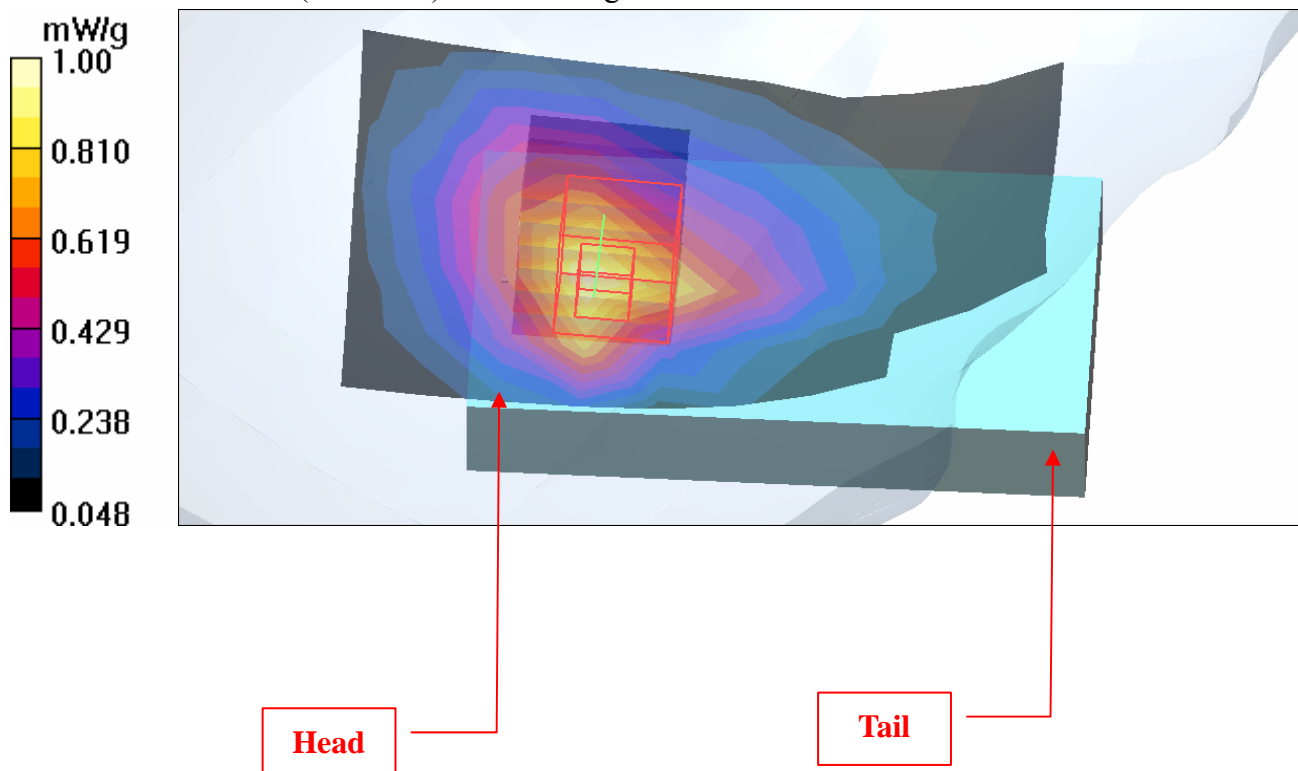

Test Laboratory: Bureau Veritas ADT

M13-Right Head-Cheek-CDMA1900-Ch600

DUT: Pocket PC Phone ; Type: RHOD500

Communication System: CDMA ; Frequency: 1880 MHz ; Duty Cycle: 1:1

Medium: HSL1900 Medium parameters used: $f = 1880$ MHz; $\sigma = 1.4$ mho/m; $\epsilon_r = 40.6$; $\rho = 1000$ kg/m³

Phantom section: Right Section ; DUT test position : Cheek ; Modulation type: OQPSK

DASY4 Configuration:

- Probe: EX3DV3 - SN3504 ; ConvF(8.08, 8.08, 8.08) ; Calibrated: 2009/1/21

- Sensor-Surface: 3mm (Mechanical Surface Detection)

- Electronics: DAE3 Sn510 ; Calibrated: 2009/1/21

- Phantom: SAM 12; Type: SAM V4.0; Serial: TP 1202

- Measurement SW: DASY4, V4.7 Build 80 ; Postprocessing SW: SEMCAD, V1.8 Build 186

Touch position - Mid Channel 600/Area Scan (6x10x1): Measurement grid: dx=15mm, dy=15mm

Maximum value of SAR (measured) = 1.07 mW/g

Touch position - Mid Channel 600/Zoom Scan (7x7x7) (7x7x7)/Cube 0: Measurement grid: dx=5mm, dy=5mm, dz=5mm

Reference Value = 22.6 V/m

Peak SAR (extrapolated) = 1.37 W/kg

SAR(1 g) = 0.858 mW/g; SAR(10 g) = 0.508 mW/g

Maximum value of SAR (measured) = 1.02 mW/g

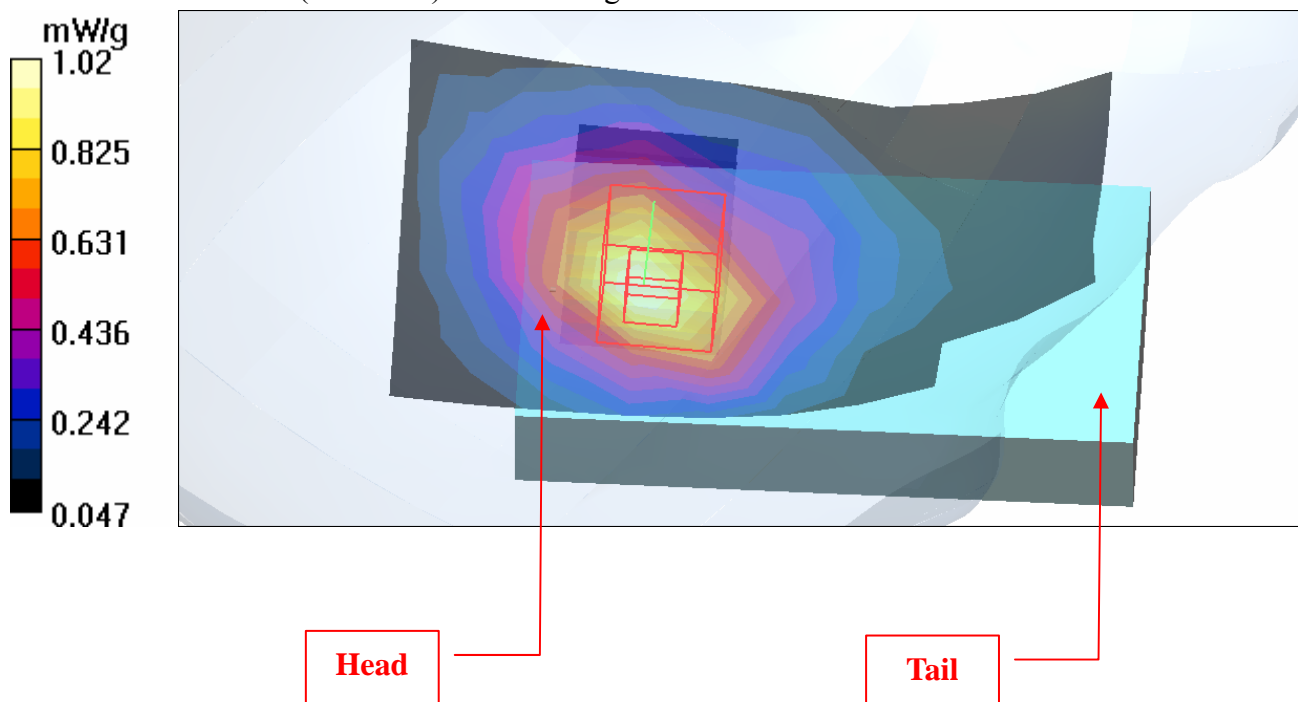

Test Laboratory: Bureau Veritas ADT

M13-Right Head-Cheek-CDMA1900-Ch1175

DUT: Pocket PC Phone ; Type: RHOD500

Communication System: CDMA ; Frequency: 1908.75 MHz ; Duty Cycle: 1:1

Medium: HSL1900 Medium parameters used: $f = 1908.75$ MHz; $\sigma = 1.43$ mho/m; $\epsilon_r = 40.5$; $\rho = 1000$ kg/m³

Phantom section: Right Section ; DUT test position : Cheek ; Modulation type: OQPSK

DASY4 Configuration:

- Probe: EX3DV3 - SN3504 ; ConvF(8.08, 8.08, 8.08) ; Calibrated: 2009/1/21
- Sensor-Surface: 3mm (Mechanical Surface Detection)
- Electronics: DAE3 Sn510 ; Calibrated: 2009/1/21
- Phantom: SAM 12; Type: SAM V4.0; Serial: TP 1202
- Measurement SW: DASY4, V4.7 Build 80 ; Postprocessing SW: SEMCAD, V1.8 Build 186

Touch position - High Channel 1175/Area Scan (6x10x1): Measurement grid: dx=15mm, dy=15mm

Maximum value of SAR (measured) = 1.34 mW/g

Touch position - High Channel 1175/Zoom Scan (7x7x7) (7x7x7)/Cube 0: Measurement grid: dx=5mm, dy=5mm, dz=5mm

Reference Value = 27.7 V/m

Peak SAR (extrapolated) = 1.78 W/kg

SAR(1 g) = 1.1 mW/g; SAR(10 g) = 0.681 mW/g

Maximum value of SAR (measured) = 1.31 mW/g

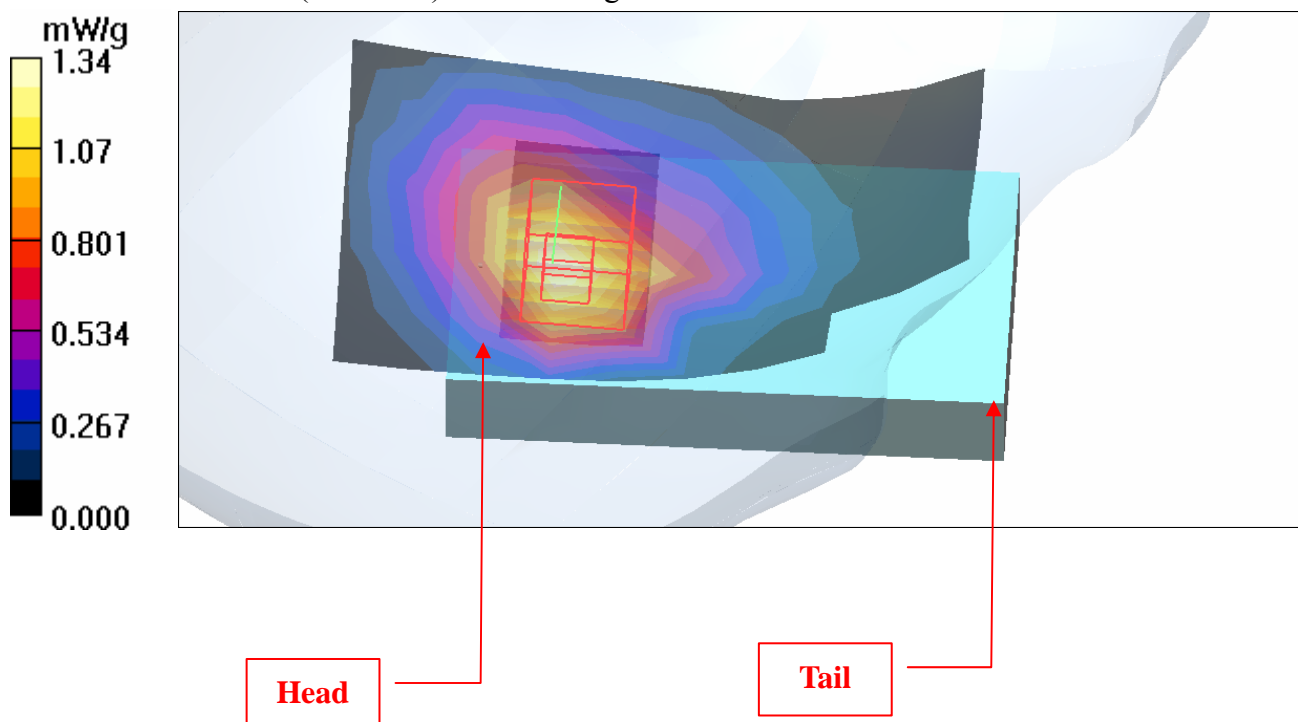

Test Laboratory: Bureau Veritas ADT

M14-Right Head-Tilt-CDMA1900-Ch25**DUT: Pocket PC Phone ; Type: RHOD500**

Communication System: CDMA ; Frequency: 1851.25 MHz; Duty Cycle: 1:1

Medium: HSL1900 Medium parameters used: $f = 1851.25$ MHz; $\sigma = 1.36$ mho/m; $\epsilon_r = 40.6$; $\rho = 1000$ kg/m³

Phantom section: Right Section ; DUT test position : Tilt ; Modulation type: OQPSK

DASY4 Configuration:

- Probe: EX3DV3 - SN3504 ; ConvF(8.08, 8.08, 8.08) ; Calibrated: 2009/1/21

- Sensor-Surface: 3mm (Mechanical Surface Detection)

- Electronics: DAE3 Sn510 ; Calibrated: 2009/1/21

- Phantom: SAM 12; Type: SAM V4.0; Serial: TP 1202

- Measurement SW: DASY4, V4.7 Build 80 ; Postprocessing SW: SEMCAD, V1.8 Build 186

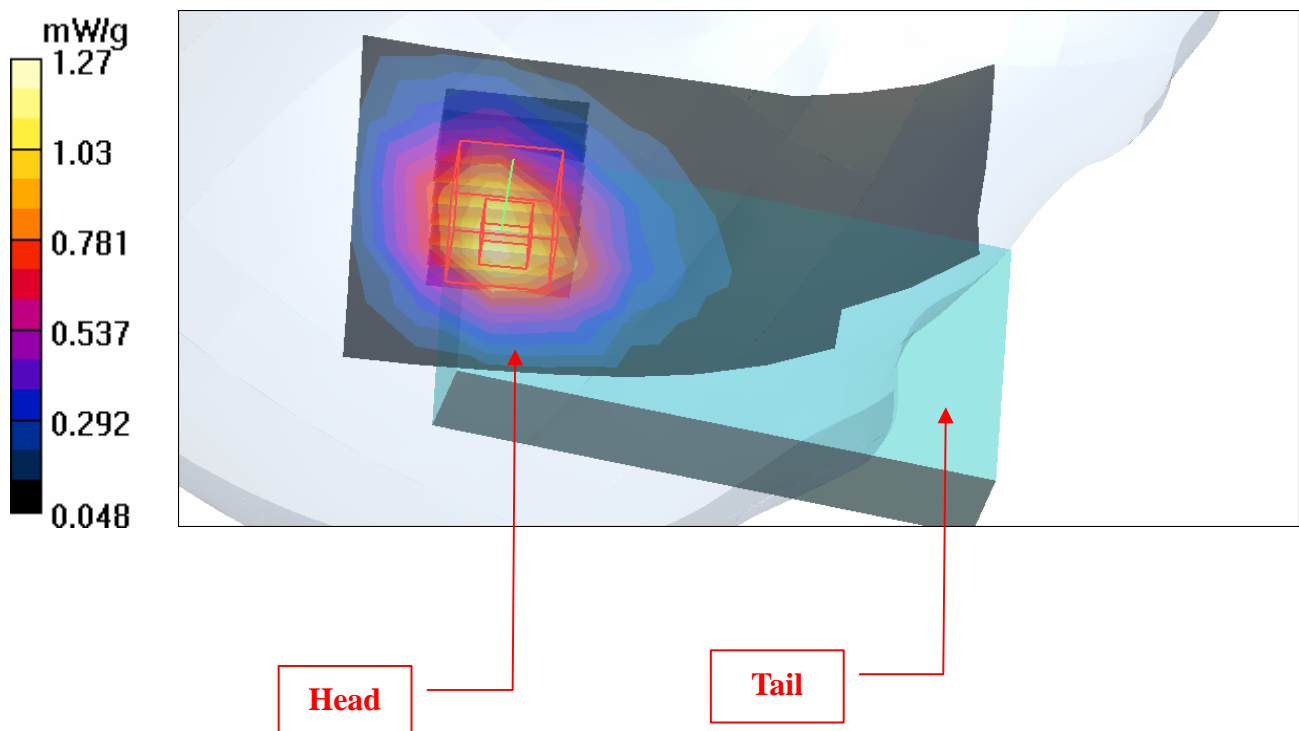
Tilt position - Low Channel 25/Area Scan (6x10x1): Measurement grid: dx=15mm, dy=15mm
Maximum value of SAR (measured) = 1.18 mW/g**Tilt position - Low Channel 25/Zoom Scan (7x7x7) (7x7x7)/Cube 0:** Measurement grid:
dx=5mm, dy=5mm, dz=5mm
Reference Value = 30.3 V/m
Peak SAR (extrapolated) = 1.73 W/kg
SAR(1 g) = 1.06 mW/g; SAR(10 g) = 0.637 mW/g
Maximum value of SAR (measured) = 1.27 mW/g

Test Laboratory: Bureau Veritas ADT

M14-Right Head-Tilt-CDMA1900-Ch600

DUT: Pocket PC Phone ; Type: RHOD500

Communication System: CDMA ; Frequency: 1880 MHz; Duty Cycle: 1:1

Medium: HSL1900 Medium parameters used: $f = 1880$ MHz; $\sigma = 1.4$ mho/m; $\epsilon_r = 40.6$; $\rho = 1000$ kg/m³

Phantom section: Right Section ; DUT test position : Tilt ; Modulation type: OQPSK

DASY4 Configuration:

- Probe: EX3DV3 - SN3504 ; ConvF(8.08, 8.08, 8.08) ; Calibrated: 2009/1/21
- Sensor-Surface: 3mm (Mechanical Surface Detection)
- Electronics: DAE3 Sn510 ; Calibrated: 2009/1/21
- Phantom: SAM 12; Type: SAM V4.0; Serial: TP 1202
- Measurement SW: DASY4, V4.7 Build 80 ; Postprocessing SW: SEMCAD, V1.8 Build 186

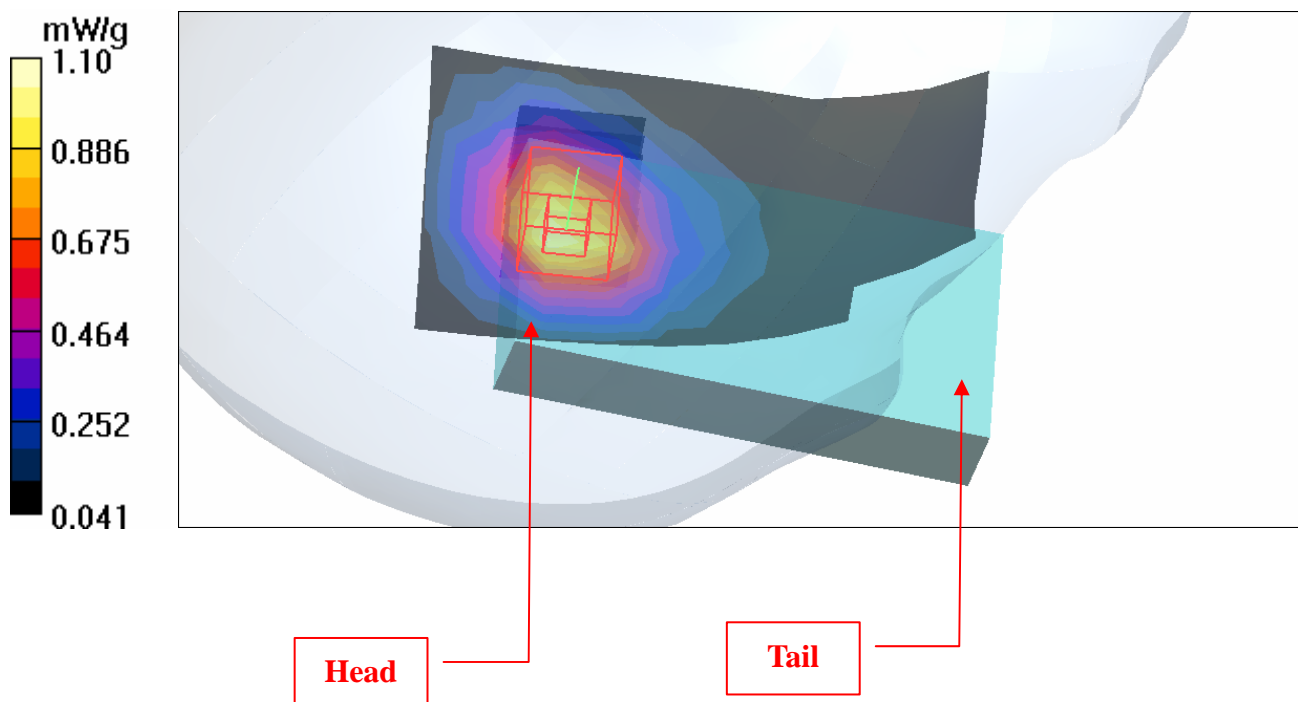
Tilt position - Mid Channel 600/Area Scan (6x10x1): Measurement grid: dx=15mm, dy=15mm
Maximum value of SAR (measured) = 0.970 mW/g**Tilt position - Mid Channel 600/Zoom Scan (7x7x7) (7x7x7)/Cube 0:** Measurement grid:
dx=5mm, dy=5mm, dz=5mm
Reference Value = 27.1 V/m
Peak SAR (extrapolated) = 1.48 W/kg
SAR(1 g) = 0.916 mW/g; SAR(10 g) = 0.555 mW/g
Maximum value of SAR (measured) = 1.10 mW/g

Test Laboratory: Bureau Veritas ADT

M14-Right Head-Tilt-CDMA1900-Ch1175

DUT: Pocket PC Phone ; Type: RHOD500

Communication System: CDMA ; Frequency: 1908.75 MHz; Duty Cycle: 1:1

Medium: HSL1900 Medium parameters used: $f = 1908.75$ MHz; $\sigma = 1.43$ mho/m; $\epsilon_r = 40.5$; $\rho = 1000$ kg/m³

Phantom section: Right Section ; DUT test position : Tilt ; Modulation type: OQPSK

DASY4 Configuration:

- Probe: EX3DV3 - SN3504 ; ConvF(8.08, 8.08, 8.08) ; Calibrated: 2009/1/21

- Sensor-Surface: 3mm (Mechanical Surface Detection)

- Electronics: DAE3 Sn510 ; Calibrated: 2009/1/21

- Phantom: SAM 12; Type: SAM V4.0; Serial: TP 1202

- Measurement SW: DASY4, V4.7 Build 80 ; Postprocessing SW: SEMCAD, V1.8 Build 186

Tilt position - High Channel 1175/Area Scan (6x10x1): Measurement grid: dx=15mm, dy=15mm

Maximum value of SAR (measured) = 1.25 mW/g

Tilt position - High Channel 1175/Zoom Scan (7x7x7) (7x7x7)/Cube 0: Measurement grid: dx=5mm, dy=5mm, dz=5mm

Reference Value = 29.3 V/m

Peak SAR (extrapolated) = 1.63 W/kg

SAR(1 g) = 1.07 mW/g; SAR(10 g) = 0.647 mW/g

Maximum value of SAR (measured) = 1.27 mW/g

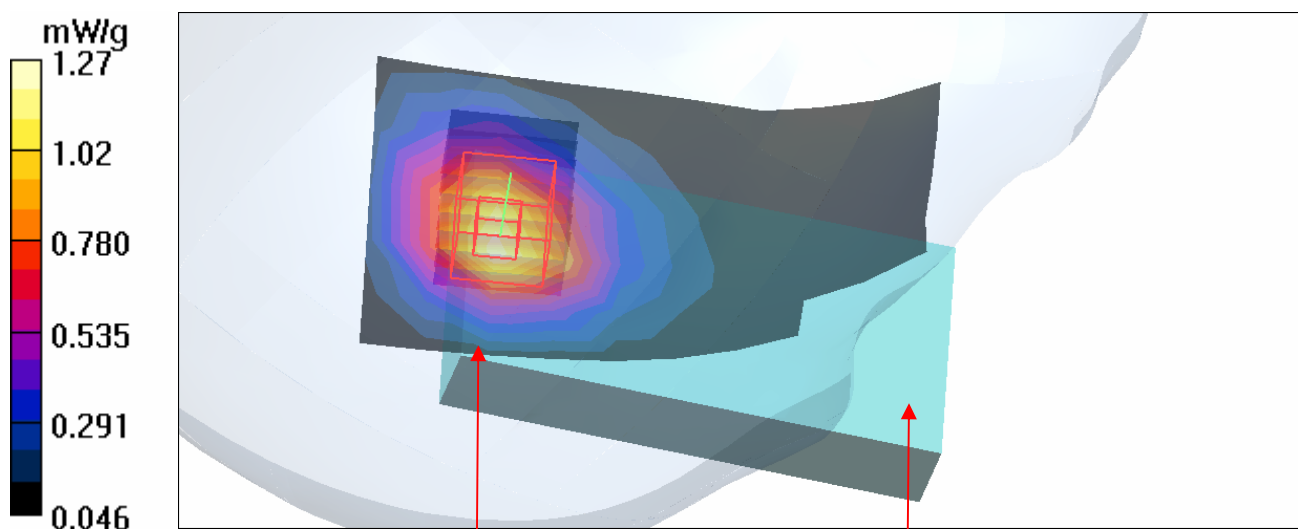
**Head****Tail**

Test Laboratory: Bureau Veritas ADT

M15-Left Head-Cheek-CDMA1900-Ch25**DUT: Pocket PC Phone ; Type: RHOD500**

Communication System: CDMA ; Frequency: 1851.25 MHz ; Duty Cycle: 1:1

Medium: HSL1900 Medium parameters used: $f = 1851.25$ MHz; $\sigma = 1.36$ mho/m; $\epsilon_r = 40.6$; $\rho = 1000$ kg/m³

Phantom section: Left Section ; DUT test position : Cheek ; Modulation type: OQPSK

DASY4 Configuration:

- Probe: EX3DV3 - SN3504 ; ConvF(8.08, 8.08, 8.08) ; Calibrated: 2009/1/21

- Sensor-Surface: 3mm (Mechanical Surface Detection)

- Electronics: DAE3 Sn510 ; Calibrated: 2009/1/21

- Phantom: SAM 12; Type: SAM V4.0; Serial: TP 1202

- Measurement SW: DASY4, V4.7 Build 80 ; Postprocessing SW: SEMCAD, V1.8 Build 186

Touch position - Low Channel 25/Area Scan (6x10x1): Measurement grid: dx=15mm, dy=15mm

Maximum value of SAR (measured) = 1.19 mW/g

Touch position - Low Channel 25/Zoom Scan (7x7x7) (7x7x7)/Cube 0: Measurement grid: dx=5mm, dy=5mm, dz=5mm

Reference Value = 22.5 V/m

Peak SAR (extrapolated) = 1.86 W/kg

SAR(1 g) = 1.09 mW/g; SAR(10 g) = 0.651 mW/g

Maximum value of SAR (measured) = 1.32 mW/g

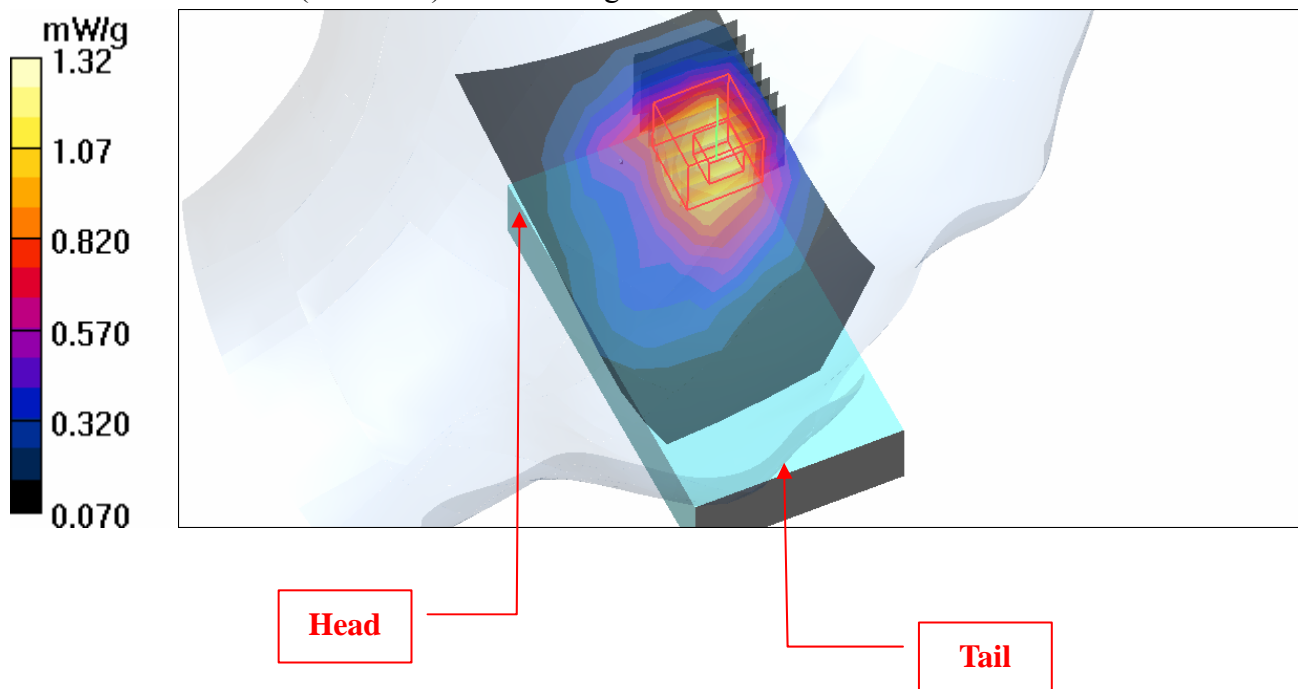

Test Laboratory: Bureau Veritas ADT

M15-Left Head-Cheek-CDMA1900-Ch600

DUT: Pocket PC Phone ; Type: RHOD500

Communication System: CDMA ; Frequency: 1880 MHz ; Duty Cycle: 1:1

Medium: HSL1900 Medium parameters used: $f = 1880$ MHz; $\sigma = 1.4$ mho/m; $\epsilon_r = 40.6$; $\rho = 1000$ kg/m³

Phantom section: Left Section ; DUT test position : Cheek ; Modulation type: OQPSK

DASY4 Configuration:

- Probe: EX3DV3 - SN3504 ; ConvF(8.08, 8.08, 8.08) ; Calibrated: 2009/1/21

- Sensor-Surface: 3mm (Mechanical Surface Detection)

- Electronics: DAE3 Sn510 ; Calibrated: 2009/1/21

- Phantom: SAM 12; Type: SAM V4.0; Serial: TP 1202

- Measurement SW: DASY4, V4.7 Build 80 ; Postprocessing SW: SEMCAD, V1.8 Build 186

Touch position - Mid Channel 600/Area Scan (6x10x1): Measurement grid: dx=15mm, dy=15mm

Maximum value of SAR (measured) = 1.27 mW/g

Touch position - Mid Channel 600/Zoom Scan (7x7x7) (7x7x7)/Cube 0: Measurement grid: dx=5mm, dy=5mm, dz=5mm

Reference Value = 21.8 V/m

Peak SAR (extrapolated) = 1.87 W/kg

SAR(1 g) = 1.07 mW/g; SAR(10 g) = 0.638 mW/g

Maximum value of SAR (measured) = 1.31 mW/g

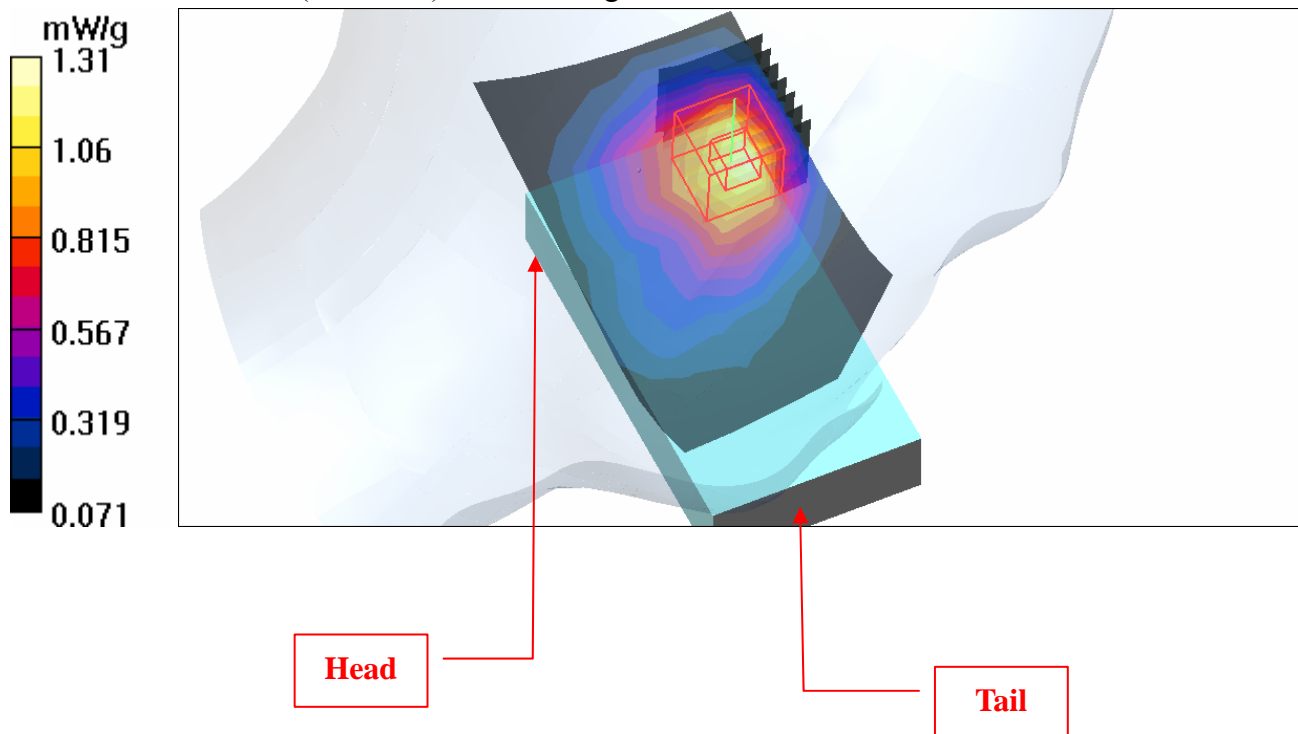

Test Laboratory: Bureau Veritas ADT

M15-Left Head-Cheek-CDMA1900-Ch1175

DUT: Pocket PC Phone ; Type: RHOD500

Communication System: CDMA ; Frequency: 1908.75 MHz ; Duty Cycle: 1:1

Medium: HSL1900 Medium parameters used: $f = 1908.75 \text{ MHz}$; $\sigma = 1.43 \text{ mho/m}$; $\epsilon_r = 40.5$; $\rho = 1000 \text{ kg/m}^3$

Phantom section: Left Section ; DUT test position : Cheek ; Modulation type: OQPSK

DASY4 Configuration:

- Probe: EX3DV3 - SN3504 ; ConvF(8.08, 8.08, 8.08) ; Calibrated: 2009/1/21
- Sensor-Surface: 3mm (Mechanical Surface Detection)
- Electronics: DAE3 Sn510 ; Calibrated: 2009/1/21
- Phantom: SAM 12; Type: SAM V4.0; Serial: TP 1202
- Measurement SW: DASY4, V4.7 Build 80 ; Postprocessing SW: SEMCAD, V1.8 Build 186

Touch position - High Channel 1175/Area Scan (6x10x1): Measurement grid: $dx=15\text{mm}$, $dy=15\text{mm}$

Maximum value of SAR (measured) = 1.72 mW/g

Touch position - High Channel 1175/Zoom Scan (7x7x7) (7x7x7)/Cube 0: Measurement grid: $dx=5\text{mm}$, $dy=5\text{mm}$, $dz=5\text{mm}$

Reference Value = 24.6 V/m

Peak SAR (extrapolated) = 2.53 W/kg

SAR(1 g) = 1.41 mW/g; SAR(10 g) = 0.813 mW/g

Maximum value of SAR (measured) = 1.76 mW/g

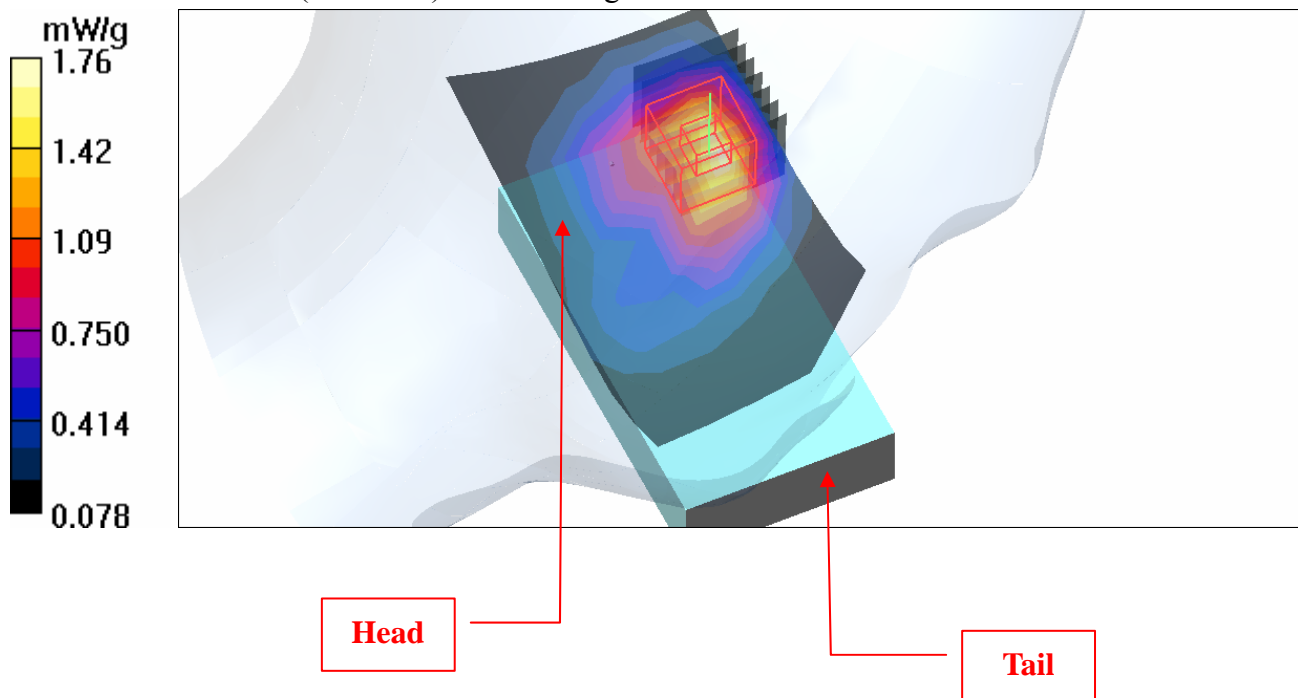

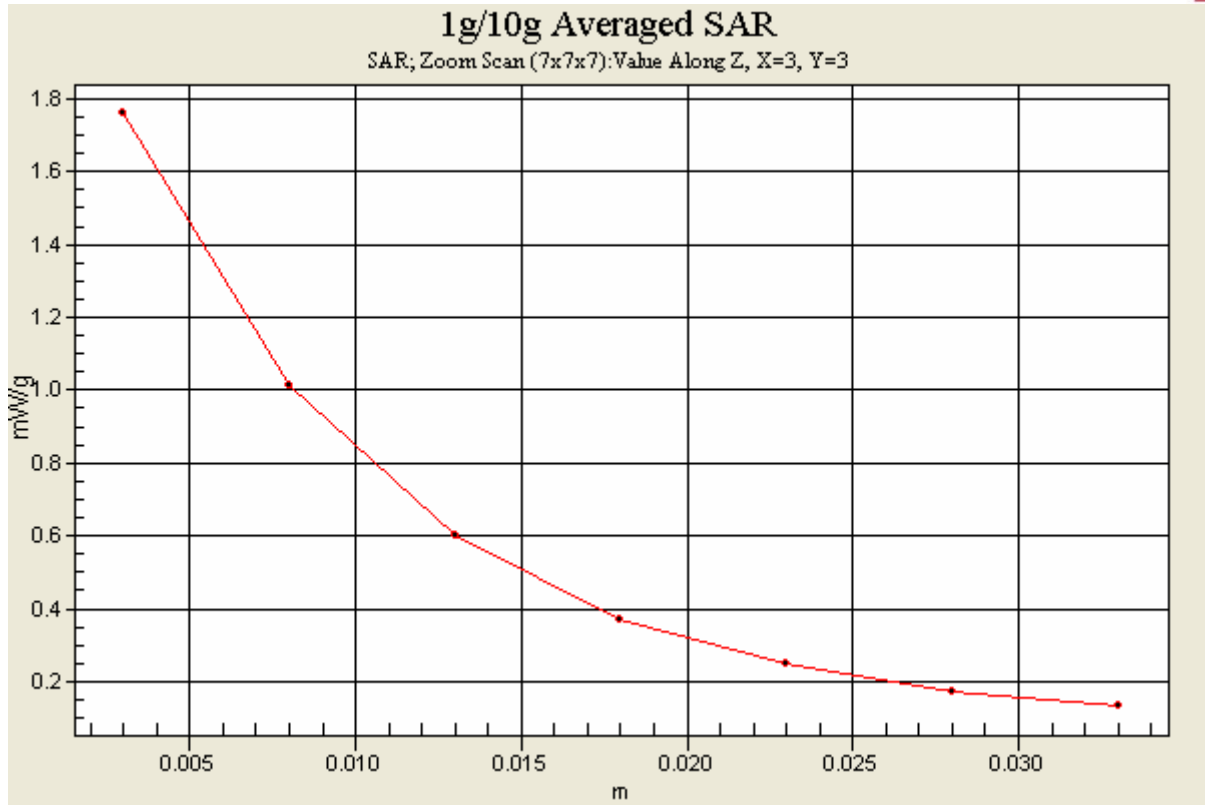

Test Laboratory: Bureau Veritas ADT

M16-Left Head-Tilt-CDMA1900-Ch25

DUT: Pocket PC Phone ; Type: RHOD500

Communication System: CDMA ; Frequency: 1851.25 MHz; Duty Cycle: 1:1

Medium: HSL1900 Medium parameters used: $f = 1851.25$ MHz; $\sigma = 1.36$ mho/m; $\epsilon_r = 40.6$; $\rho = 1000$ kg/m³

Phantom section: Left Section ; DUT test position : Tilt ; Modulation type: OQPSK

DASY4 Configuration:

- Probe: EX3DV3 - SN3504 ; ConvF(8.08, 8.08, 8.08) ; Calibrated: 2009/1/21

- Sensor-Surface: 3mm (Mechanical Surface Detection)

- Electronics: DAE3 Sn510 ; Calibrated: 2009/1/21

- Phantom: SAM 12; Type: SAM V4.0; Serial: TP 1202

- Measurement SW: DASY4, V4.7 Build 80 ; Postprocessing SW: SEMCAD, V1.8 Build 186

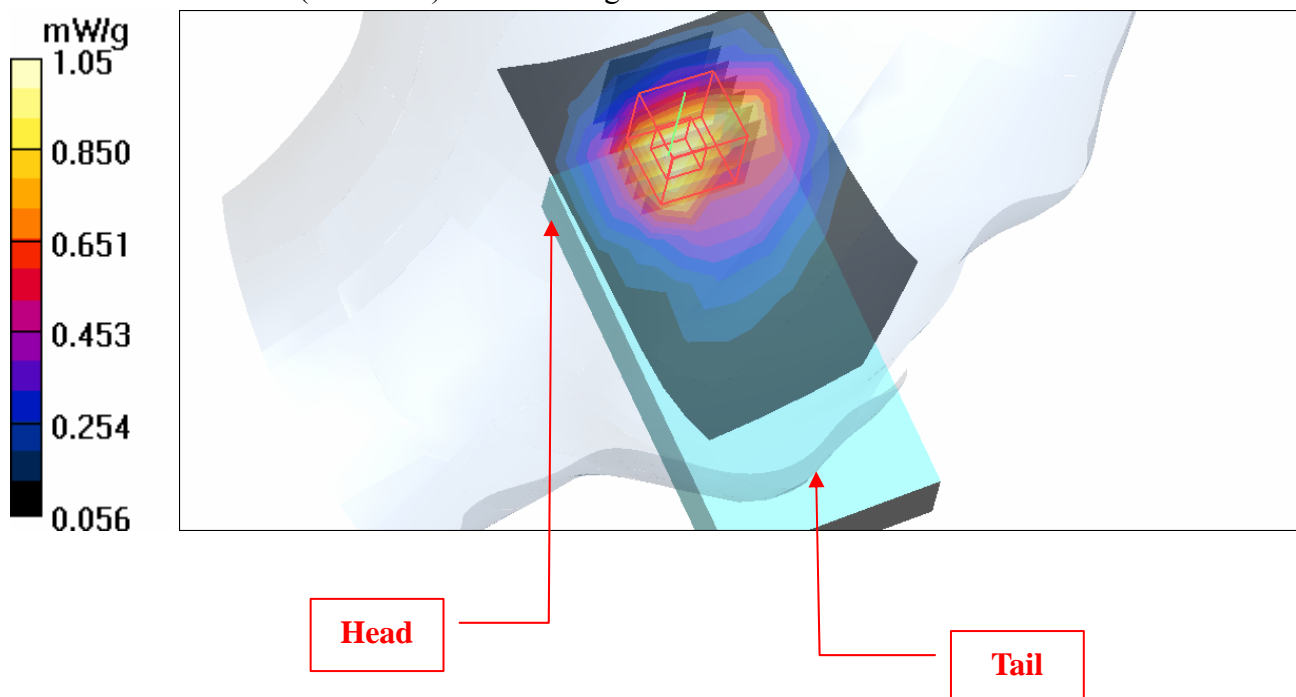
Tilt position - Low Channel 25/Area Scan (6x10x1): Measurement grid: dx=15mm, dy=15mm
Maximum value of SAR (measured) = 0.969 mW/g**Tilt position - Low Channel 25/Zoom Scan (7x7x7) (7x7x7)/Cube 0:** Measurement grid:
dx=5mm, dy=5mm, dz=5mm
Reference Value = 26.6 V/m
Peak SAR (extrapolated) = 1.36 W/kg
SAR(1 g) = 0.901 mW/g; SAR(10 g) = 0.564 mW/g
Maximum value of SAR (measured) = 1.05 mW/g

Test Laboratory: Bureau Veritas ADT

M16-Left Head-Tilt-CDMA1900-Ch600

DUT: Pocket PC Phone ; Type: RHOD500

Communication System: CDMA ; Frequency: 1880 MHz; Duty Cycle: 1:1

Medium: HSL1900 Medium parameters used: $f = 1880$ MHz; $\sigma = 1.4$ mho/m; $\epsilon_r = 40.6$; $\rho = 1000$ kg/m³

Phantom section: Left Section ; DUT test position : Tilt ; Modulation type: OQPSK

DASY4 Configuration:

- Probe: EX3DV3 - SN3504 ; ConvF(8.08, 8.08, 8.08) ; Calibrated: 2009/1/21
- Sensor-Surface: 3mm (Mechanical Surface Detection)
- Electronics: DAE3 Sn510 ; Calibrated: 2009/1/21
- Phantom: SAM 12; Type: SAM V4.0; Serial: TP 1202
- Measurement SW: DASY4, V4.7 Build 80 ; Postprocessing SW: SEMCAD, V1.8 Build 186

Tilt position - Mid Channel 600/Area Scan (6x10x1): Measurement grid: dx=15mm, dy=15mm
Maximum value of SAR (measured) = 0.903 mW/g

Tilt position - Mid Channel 600/Zoom Scan (7x7x7) (7x7x7)/Cube 0: Measurement grid:
dx=5mm, dy=5mm, dz=5mm
Reference Value = 26.0 V/m
Peak SAR (extrapolated) = 1.33 W/kg
SAR(1 g) = 0.870 mW/g; SAR(10 g) = 0.540 mW/g
Maximum value of SAR (measured) = 1.03 mW/g

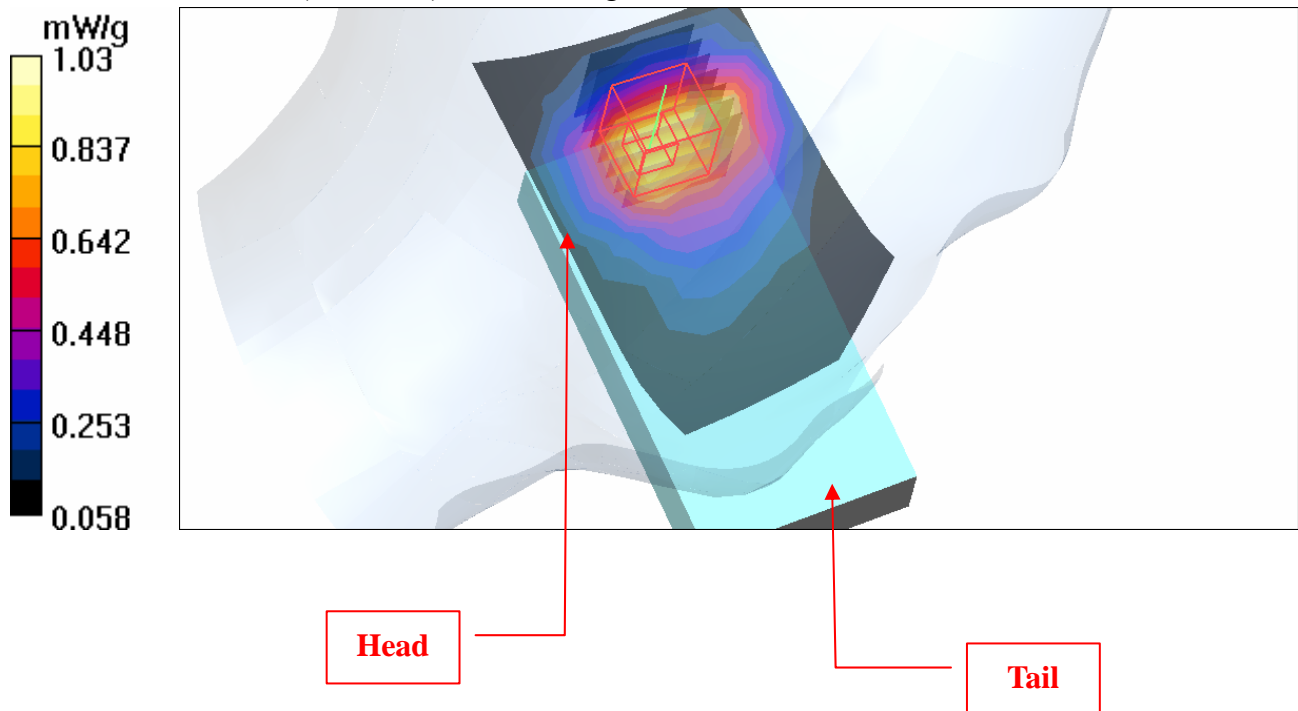

Test Laboratory: Bureau Veritas ADT

M16-Left Head-Tilt-CDMA1900-Ch1175

DUT: Pocket PC Phone ; Type: RHOD500

Communication System: CDMA ; Frequency: 1908.75 MHz; Duty Cycle: 1:1

Medium: HSL1900 Medium parameters used: $f = 1908.75$ MHz; $\sigma = 1.43$ mho/m; $\epsilon_r = 40.5$; $\rho = 1000$ kg/m³

Phantom section: Left Section ; DUT test position : Tilt ; Modulation type: OQPSK

DASY4 Configuration:

- Probe: EX3DV3 - SN3504 ; ConvF(8.08, 8.08, 8.08) ; Calibrated: 2009/1/21

- Sensor-Surface: 3mm (Mechanical Surface Detection)

- Electronics: DAE3 Sn510 ; Calibrated: 2009/1/21

- Phantom: SAM 12; Type: SAM V4.0; Serial: TP 1202

- Measurement SW: DASY4, V4.7 Build 80 ; Postprocessing SW: SEMCAD, V1.8 Build 186

Tilt position - High Channel 1175/Area Scan (6x10x1): Measurement grid: $dx=15$ mm, $dy=15$ mm

Maximum value of SAR (measured) = 1.20 mW/g

Tilt position - High Channel 1175/Zoom Scan (7x7x7) (7x7x7)/Cube 0: Measurement grid: $dx=5$ mm, $dy=5$ mm, $dz=5$ mm

Reference Value = 29.4 V/m

Peak SAR (extrapolated) = 1.64 W/kg

SAR(1 g) = 1.08 mW/g; SAR(10 g) = 0.664 mW/g

Maximum value of SAR (measured) = 1.28 mW/g

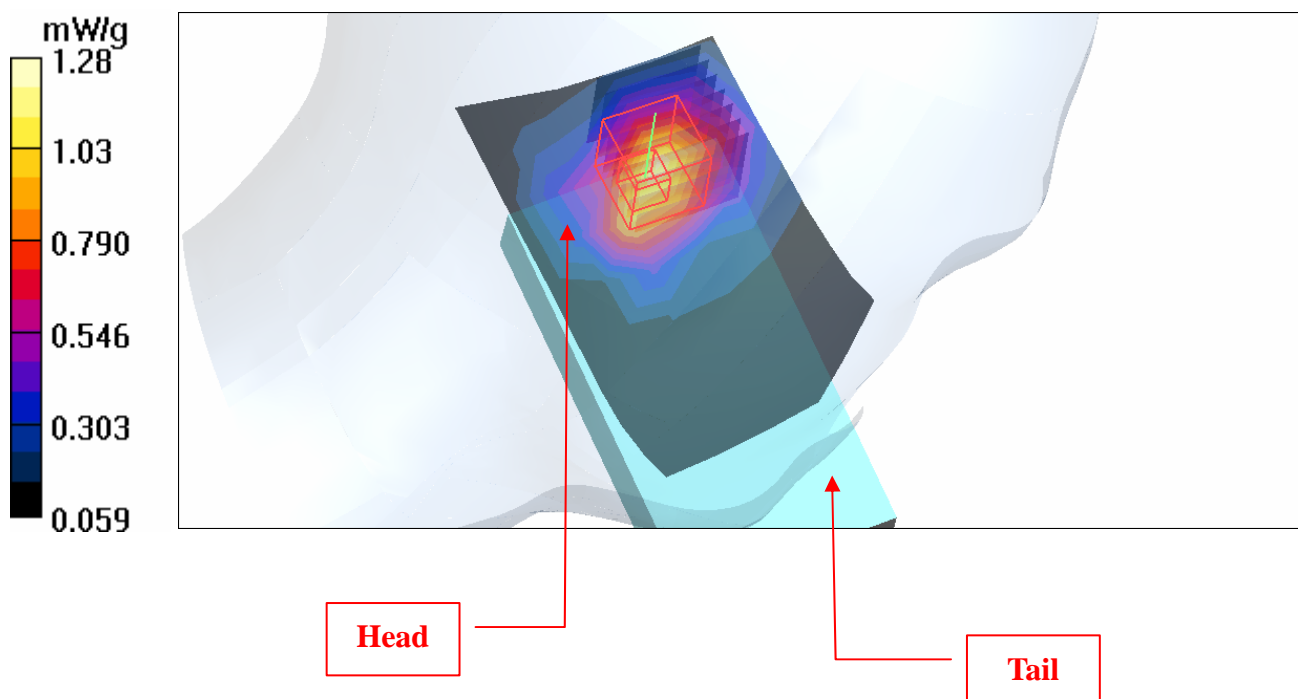

Test Laboratory: Bureau Veritas ADT

M17-Left Head-Cheek-CDMA1900-Ch1175 / 2nd**DUT: Pocket PC Phone ; Type: RHOD500**

Communication System: CDMA ; Frequency: 1908.75 MHz ; Duty Cycle: 1:1

Medium: HSL1900 Medium parameters used: $f = 1908.75$ MHz; $\sigma = 1.43$ mho/m; $\epsilon_r = 40.5$; $\rho = 1000$ kg/m³

Phantom section: Left Section ; DUT test position : Cheek ; Modulation type: OQPSK

DASY4 Configuration:

- Probe: EX3DV3 - SN3504 ; ConvF(8.08, 8.08, 8.08) ; Calibrated: 2009/1/21
- Sensor-Surface: 3mm (Mechanical Surface Detection)
- Electronics: DAE3 Sn510; Calibrated: 2009/1/21
- Phantom: SAM 12; Type: SAM V4.0; Serial: TP 1202
- Measurement SW: DASY4, V4.7 Build 80; Postprocessing SW: SEMCAD, V1.8 Build 186

Touch position - High Channel 1175/Area Scan (6x10x1): Measurement grid: dx=15mm, dy=15mm

Maximum value of SAR (measured) = 1.63 mW/g

Touch position - High Channel 1175/Zoom Scan (7x7x7) (7x7x7)/Cube 0: Measurement grid: dx=5mm, dy=5mm, dz=5mm

Reference Value = 23.9 V/m

Peak SAR (extrapolated) = 2.45 W/kg

SAR(1 g) = 1.29 mW/g; SAR(10 g) = 0.749 mW/g

Maximum value of SAR (measured) = 1.61 mW/g

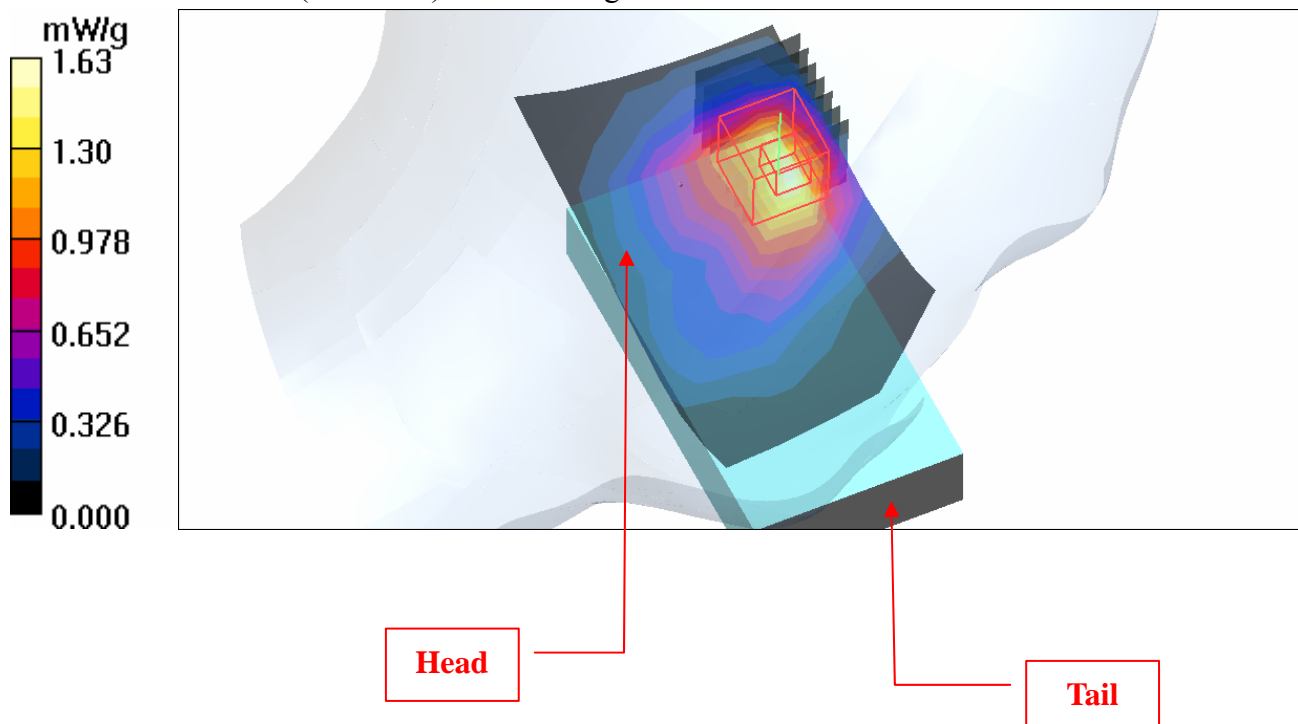

Test Laboratory: Bureau Veritas ADT

M18-Left Head-CDMA1900 SO55-Ch1175 / 3rd

DUT: Pocket PC Phone ; Type: RHOD500

Communication System: CDMA ; Frequency: 1908.75 MHz ; Duty Cycle: 1:1

Medium: HSL1900 Medium parameters used: $f = 1908.75$ MHz; $\sigma = 1.43$ mho/m; $\epsilon_r = 40.5$; $\rho = 1000$ kg/m³

Phantom section: Left Section ; DUT test position : Cheek ; Modulation type: OQPSK

DASY4 Configuration:

- Probe: EX3DV3 - SN3504 ; ConvF(8.08, 8.08, 8.08) ; Calibrated: 2009/1/21
- Sensor-Surface: 3mm (Mechanical Surface Detection)
- Electronics: DAE3 Sn510; Calibrated: 2009/1/21
- Phantom: SAM 12; Type: SAM V4.0; Serial: TP 1202
- Measurement SW: DASY4, V4.7 Build 80; Postprocessing SW: SEMCAD, V1.8 Build 186

Touch position - High Channel 1175/Area Scan (6x10x1): Measurement grid: dx=15mm, dy=15mm

Maximum value of SAR (measured) = 1.38 mW/g

Touch position - High Channel 1175/Zoom Scan (7x7x7) (7x7x7)/Cube 0: Measurement grid: dx=5mm, dy=5mm, dz=5mm

Reference Value = 24.1 V/m

Peak SAR (extrapolated) = 2.49 W/kg

SAR(1 g) = 1.32 mW/g; SAR(10 g) = 0.756 mW/g

Maximum value of SAR (measured) = 1.65 mW/g

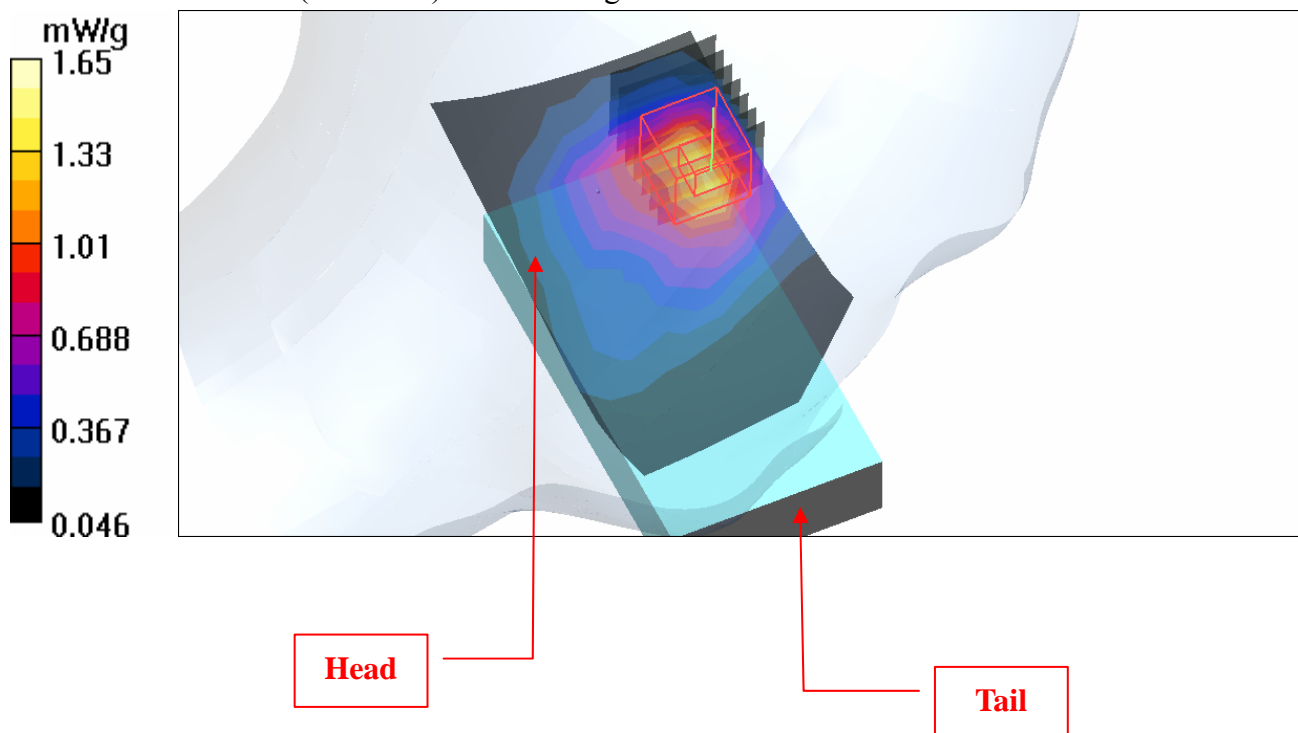

Test Laboratory: Bureau Veritas ADT

M19-Left Head-Cheek-CDMA1900-Ch1175 (Bat-00M)**DUT: Pocket PC Phone ; Type: RHOD500**

Communication System: CDMA ; Frequency: 1908.75 MHz ; Duty Cycle: 1:1

Medium: HSL1900 Medium parameters used: $f = 1908.75$ MHz; $\sigma = 1.43$ mho/m; $\epsilon_r = 40.5$; $\rho = 1000$ kg/m³

Phantom section: Left Section ; DUT test position : Cheek ; Modulation type: OQPSK

DASY4 Configuration:

- Probe: EX3DV3 - SN3504 ; ConvF(8.08, 8.08, 8.08) ; Calibrated: 2009/1/21
- Sensor-Surface: 3mm (Mechanical Surface Detection)
- Electronics: DAE3 Sn510 ; Calibrated: 2009/1/21
- Phantom: SAM 12; Type: SAM V4.0; Serial: TP 1202
- Measurement SW: DASY4, V4.7 Build 80 ; Postprocessing SW: SEMCAD, V1.8 Build 186

Touch position - High Channel 1175/Area Scan (6x10x1): Measurement grid: $dx=15$ mm, $dy=15$ mm

Maximum value of SAR (measured) = 1.33 mW/g

Touch position - High Channel 1175/Zoom Scan (7x7x7) (7x7x7)/Cube 0: Measurement grid: $dx=5$ mm, $dy=5$ mm, $dz=5$ mm

Reference Value = 21.8 V/m

Peak SAR (extrapolated) = 2.67 W/kg

SAR(1 g) = **1.34 mW/g**; SAR(10 g) = 0.749 mW/g

Maximum value of SAR (measured) = 1.47 mW/g

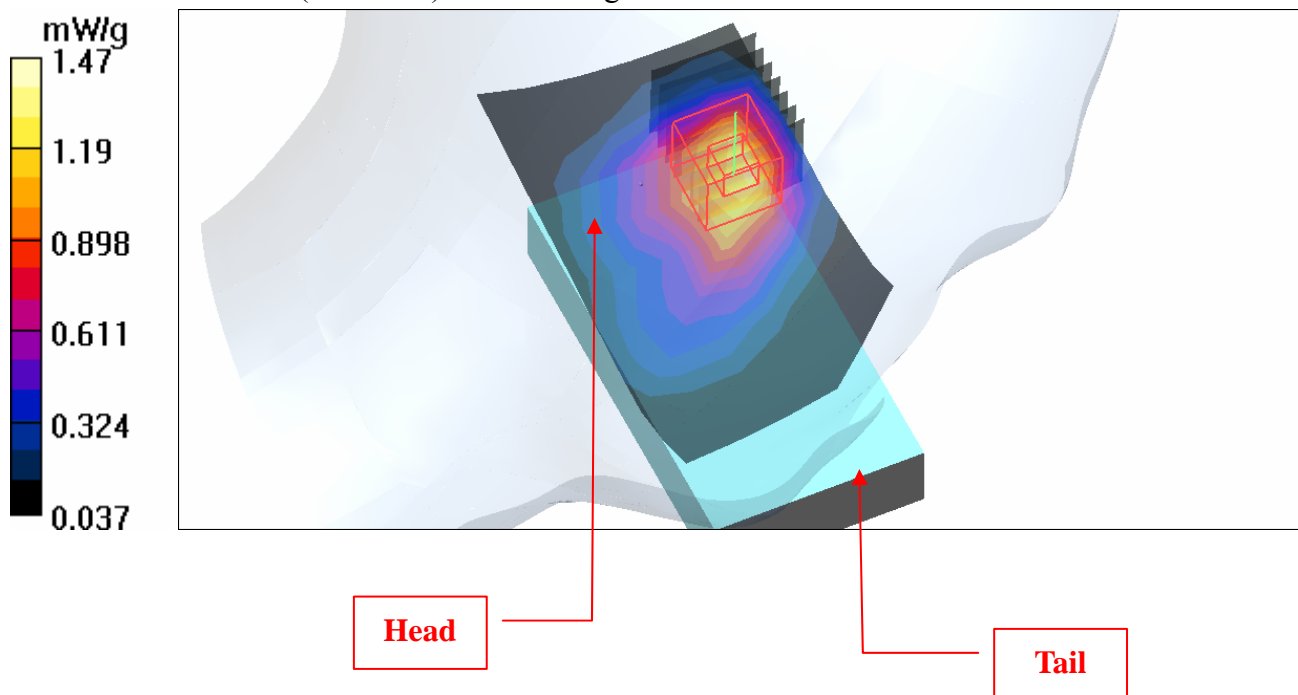

Test Laboratory: Bureau Veritas ADT

M20-Left Head-Cheek-CDMA1900-Ch1175 (Bat-01M)**DUT: Pocket PC Phone ; Type: RHOD500**

Communication System: CDMA ; Frequency: 1908.75 MHz ; Duty Cycle: 1:1

Medium: HSL1900 Medium parameters used: $f = 1908.75$ MHz; $\sigma = 1.43$ mho/m; $\epsilon_r = 40.5$; $\rho = 1000$ kg/m³

Phantom section: Left Section ; DUT test position : Cheek ; Modulation type: OQPSK

DASY4 Configuration:

- Probe: EX3DV3 - SN3504 ; ConvF(8.08, 8.08, 8.08) ; Calibrated: 2009/1/21

- Sensor-Surface: 3mm (Mechanical Surface Detection)

- Electronics: DAE3 Sn510 ; Calibrated: 2009/1/21

- Phantom: SAM 12; Type: SAM V4.0; Serial: TP 1202

- Measurement SW: DASY4, V4.7 Build 80 ; Postprocessing SW: SEMCAD, V1.8 Build 186

Touch position - High Channel 1175/Area Scan (6x10x1): Measurement grid: dx=15mm, dy=15mm

Maximum value of SAR (measured) = 1.38 mW/g

Touch position - High Channel 1175/Zoom Scan (7x7x7) (7x7x7)/Cube 0: Measurement grid: dx=5mm, dy=5mm, dz=5mm

Reference Value = 23.1 V/m

Peak SAR (extrapolated) = 2.51 W/kg

SAR(1 g) = 1.37 mW/g; SAR(10 g) = 0.781 mW/g

Maximum value of SAR (measured) = 1.49 mW/g

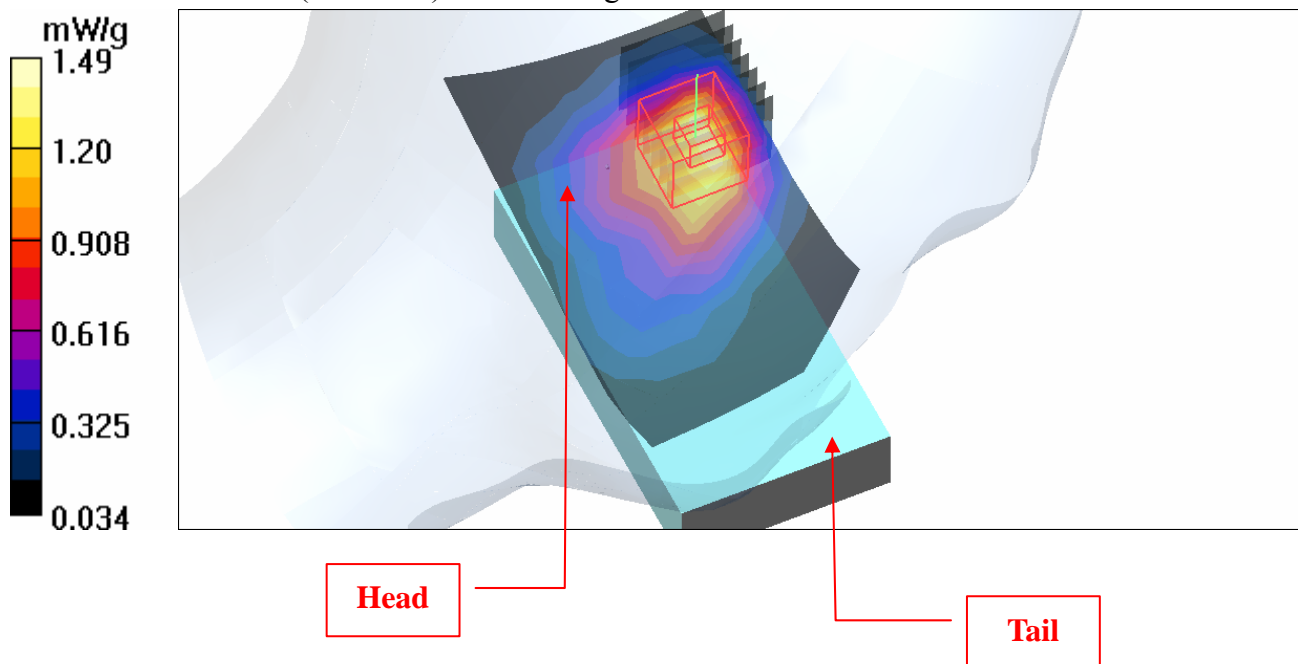

Test Laboratory: Bureau Veritas ADT

M21-Body-CDMA1900 SO32-Ch600 / Slider-off / LCD DOWN**DUT: Pocket PC Phone ; Type: RHOD500**

Communication System: CDMA ; Frequency: 1880 MHz ; Duty Cycle: 1:1

Medium: MSL1900 Medium parameters used: $f = 1880$ MHz; $\sigma = 1.52$ mho/m; $\epsilon_r = 54.5$; $\rho = 1000$ kg/m³

Phantom section: Flat Section ; DUT test position : Body ; Modulation Type: OQPSK

Separation Distance : 15 mm (The bottom side of the EUT to the Phantom)

DASY4 Configuration:

- Probe: EX3DV3 - SN3504 ; ConvF(8.21, 8.21, 8.21) ; Calibrated: 2009/1/21

- Sensor-Surface: 3mm (Mechanical Surface Detection)

- Electronics: DAE3 Sn510; Calibrated: 2009/1/21

- Phantom: SAM 12 ; Type: SAM V4.0; Serial: TP 1202

- Measurement SW: DASY4, V4.7 Build 80 ; Postprocessing SW: SEMCAD, V1.8 Build 186

Mid Channel 600/Area Scan (6x10x1): Measurement grid: dx=15mm, dy=15mm

Maximum value of SAR (measured) = 0.413 mW/g

Mid Channel 600/Zoom Scan (7x7x7) (7x7x7)/Cube 0: Measurement grid: dx=5mm, dy=5mm, dz=5mm

Reference Value = 10.2 V/m

Peak SAR (extrapolated) = 0.561 W/kg

SAR(1 g) = 0.369 mW/g; SAR(10 g) = 0.232 mW/g

Maximum value of SAR (measured) = 0.435 mW/g

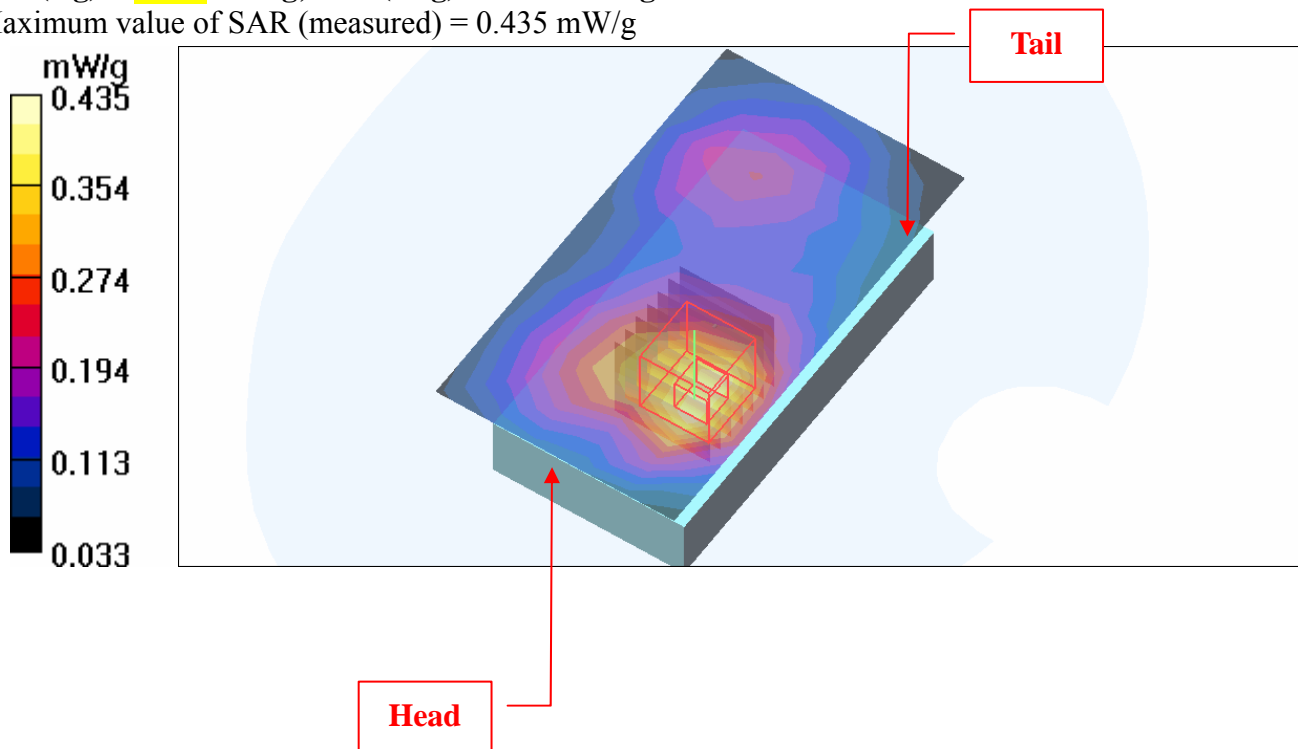

Test Laboratory: Bureau Veritas ADT

M22-Body-EVDO1900 FTAP-Ch600 / Slider-off / LCD DOWN

DUT: Pocket PC Phone ; Type: RHOD500

Communication System: CDMA ; Frequency: 1880 MHz ; Duty Cycle: 1:1
 Medium: MSL1900 Medium parameters used: $f = 1880 \text{ MHz}$; $\sigma = 1.52 \text{ mho/m}$; $\epsilon_r = 54.5$; $\rho = 1000 \text{ kg/m}^3$
 Phantom section: Flat Section ; DUT test position : Body ; Modulation Type: HPSK
 Separation Distance : 15 mm (The bottom side of the EUT to the Phantom)

DASY4 Configuration:

- Probe: EX3DV3 - SN3504 ; ConvF(8.21, 8.21, 8.21) ; Calibrated: 2009/1/21
- Sensor-Surface: 3mm (Mechanical Surface Detection)
- Electronics: DAE3 Sn510 ; Calibrated: 2009/1/21
- Phantom: SAM 12 ; Type: SAM V4.0; Serial: TP 1202
- Measurement SW: DASY4, V4.7 Build 80 ; Postprocessing SW: SEMCAD, V1.8 Build 186

Mid Channel 600/Area Scan (6x10x1): Measurement grid: $dx=15\text{mm}$, $dy=15\text{mm}$
 Maximum value of SAR (measured) = 0.466 mW/g

Mid Channel 600/Zoom Scan (7x7x7) (7x7x7)/Cube 0: Measurement grid: $dx=5\text{mm}$, $dy=5\text{mm}$, $dz=5\text{mm}$

Reference Value = 10.8 V/m

Peak SAR (extrapolated) = 0.627 W/kg

SAR(1 g) = 0.408 mW/g; SAR(10 g) = 0.258 mW/g

Maximum value of SAR (measured) = 0.484 mW/g

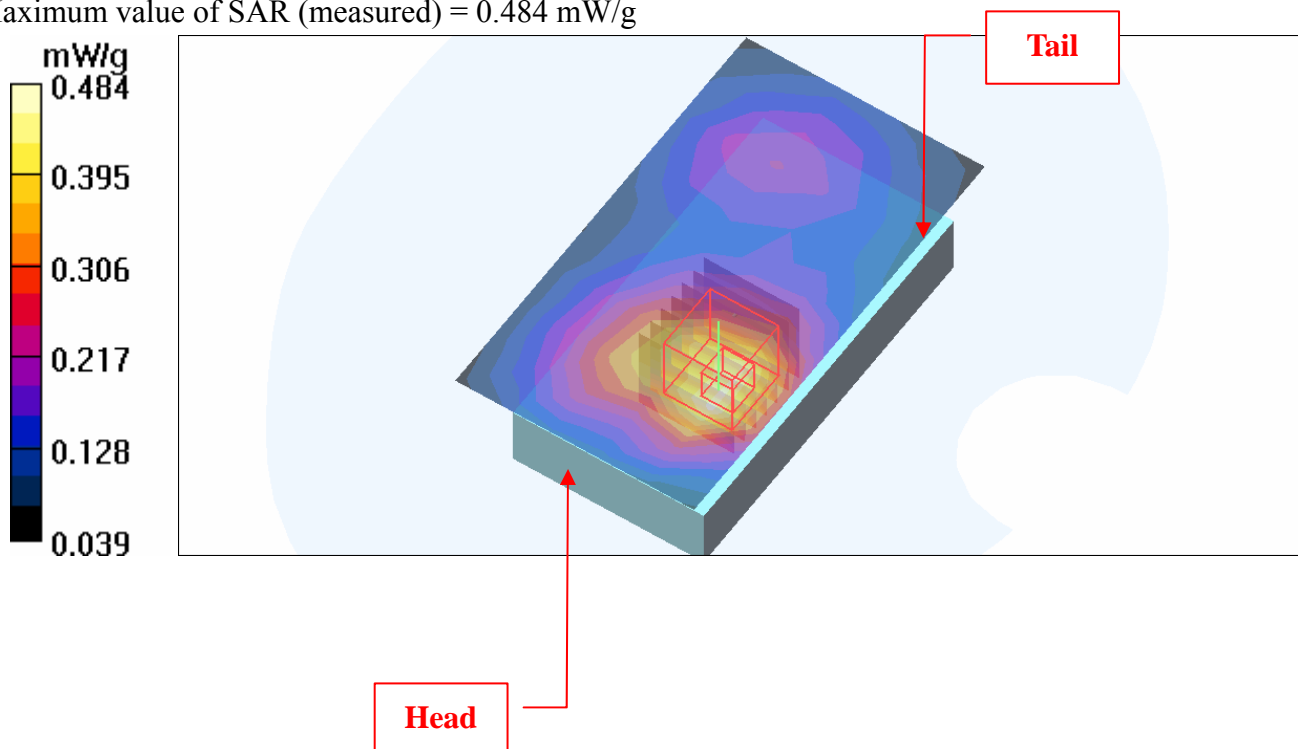

Test Laboratory: Bureau Veritas ADT

M23-Body-CDMA1900 SO32-Ch600 / Slider-off / LCD UP

DUT: Pocket PC Phone ; Type: RHOD500

Communication System: CDMA ; Frequency: 1880 MHz ; Duty Cycle: 1:1

Medium: MSL1900 Medium parameters used: $f = 1880$ MHz; $\sigma = 1.52$ mho/m; $\epsilon_r = 54.5$; $\rho = 1000$ kg/m³

Phantom section: Flat Section ; DUT test position : Body ; Modulation Type: OQPSK

Separation Distance : 15 mm (The front side of the EUT to the Phantom)

DASY4 Configuration:

- Probe: EX3DV3 - SN3504 ; ConvF(8.21, 8.21, 8.21) ; Calibrated: 2009/1/21
- Sensor-Surface: 3mm (Mechanical Surface Detection)
- Electronics: DAE3 Sn510 ; Calibrated: 2009/1/21
- Phantom: SAM 12 ; Type: SAM V4.0; Serial: TP 1202
- Measurement SW: DASY4, V4.7 Build 80 ; Postprocessing SW: SEMCAD, V1.8 Build 186

Mid Channel 600/Area Scan (9x10x1): Measurement grid: dx=15mm, dy=15mm

Maximum value of SAR (measured) = 0.154 mW/g

Mid Channel 600/Zoom Scan (7x7x7) (7x7x7)/Cube 0: Measurement grid: dx=5mm, dy=5mm, dz=5mm

Reference Value = 5.75 V/m

Peak SAR (extrapolated) = 0.212 W/kg

SAR(1 g) = 0.140 mW/g; SAR(10 g) = 0.096 mW/g

Maximum value of SAR (measured) = 0.168 mW/g

Mid Channel 600/Zoom Scan (7x7x7) (7x7x7)/Cube 1: Measurement grid: dx=5mm, dy=5mm, dz=5mm

Reference Value = 5.75 V/m

Peak SAR (extrapolated) = 0.106 W/kg

SAR(1 g) = 0.085 mW/g; SAR(10 g) = 0.066 mW/g

Maximum value of SAR (measured) = 0.094 mW/g

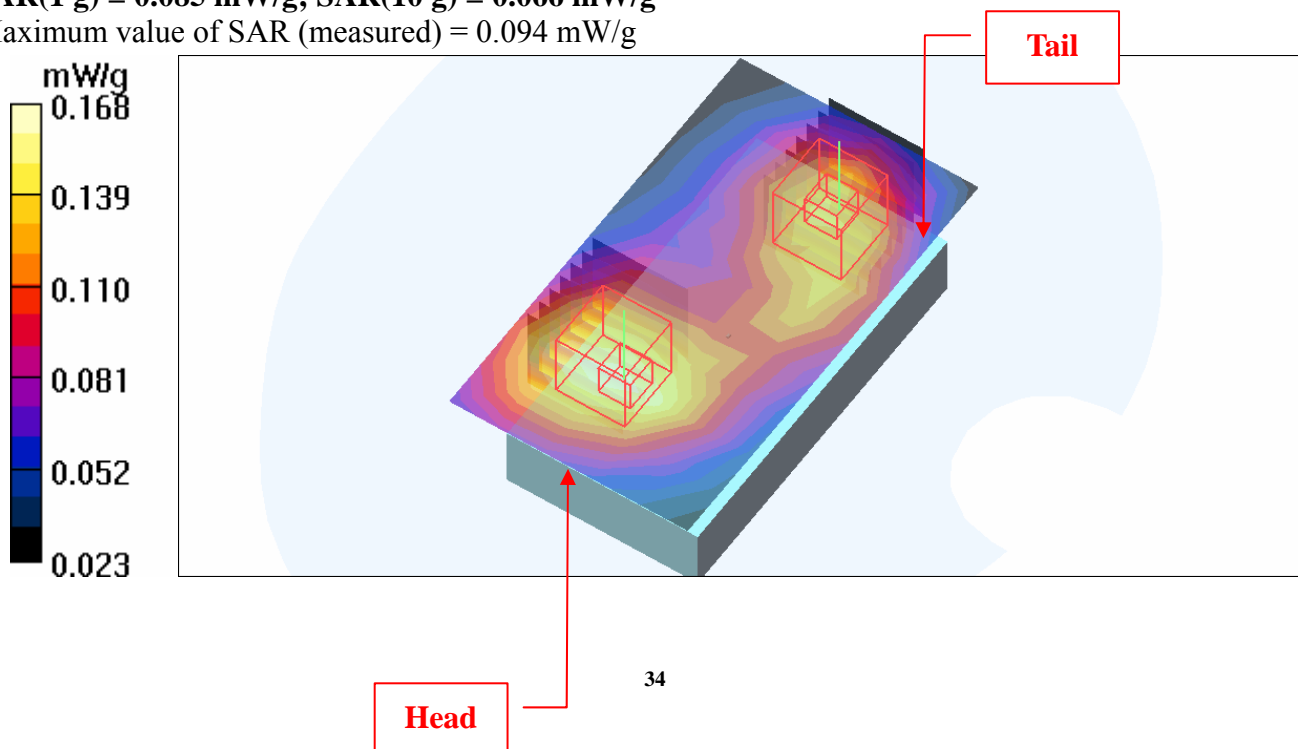

Test Laboratory: Bureau Veritas ADT

M24-Body-EVDO1900 FTAP-Ch600 / Slider-off / LCD UP

DUT: Pocket PC Phone ; Type: RHOD500

Communication System: CDMA ; Frequency: 1880 MHz ; Duty Cycle: 1:1

Medium: MSL1900 Medium parameters used: $f = 1880$ MHz; $\sigma = 1.52$ mho/m; $\epsilon_r = 54.5$; $\rho = 1000$ kg/m³

Phantom section: Flat Section ; DUT test position : Body ; Modulation Type: HPSK

Separation Distance : 15 mm (The front side of the EUT to the Phantom)

DASY4 Configuration:

- Probe: EX3DV3 - SN3504 ; ConvF(8.21, 8.21, 8.21) ; Calibrated: 2009/1/21
- Sensor-Surface: 3mm (Mechanical Surface Detection)
- Electronics: DAE3 Sn510 ; Calibrated: 2009/1/21
- Phantom: SAM 12 ; Type: SAM V4.0; Serial: TP 1202
- Measurement SW: DASY4, V4.7 Build 80 ; Postprocessing SW: SEMCAD, V1.8 Build 186

Mid Channel 600/Area Scan (9x10x1): Measurement grid: dx=15mm, dy=15mm

Maximum value of SAR (measured) = 0.203 mW/g

Mid Channel 600/Zoom Scan (7x7x7) (7x7x7)/Cube 0: Measurement grid: dx=5mm, dy=5mm, dz=5mm

Reference Value = 6.13 V/m

Peak SAR (extrapolated) = 0.235 W/kg

SAR(1 g) = 0.167 mW/g; SAR(10 g) = 0.112 mW/g

Maximum value of SAR (measured) = 0.191 mW/g

Mid Channel 600/Zoom Scan (7x7x7) (7x7x7)/Cube 1: Measurement grid: dx=5mm, dy=5mm, dz=5mm

Reference Value = 6.13 V/m

Peak SAR (extrapolated) = 0.212 W/kg

SAR(1 g) = 0.146 mW/g; SAR(10 g) = 0.098 mW/g

Maximum value of SAR (measured) = 0.160 mW/g

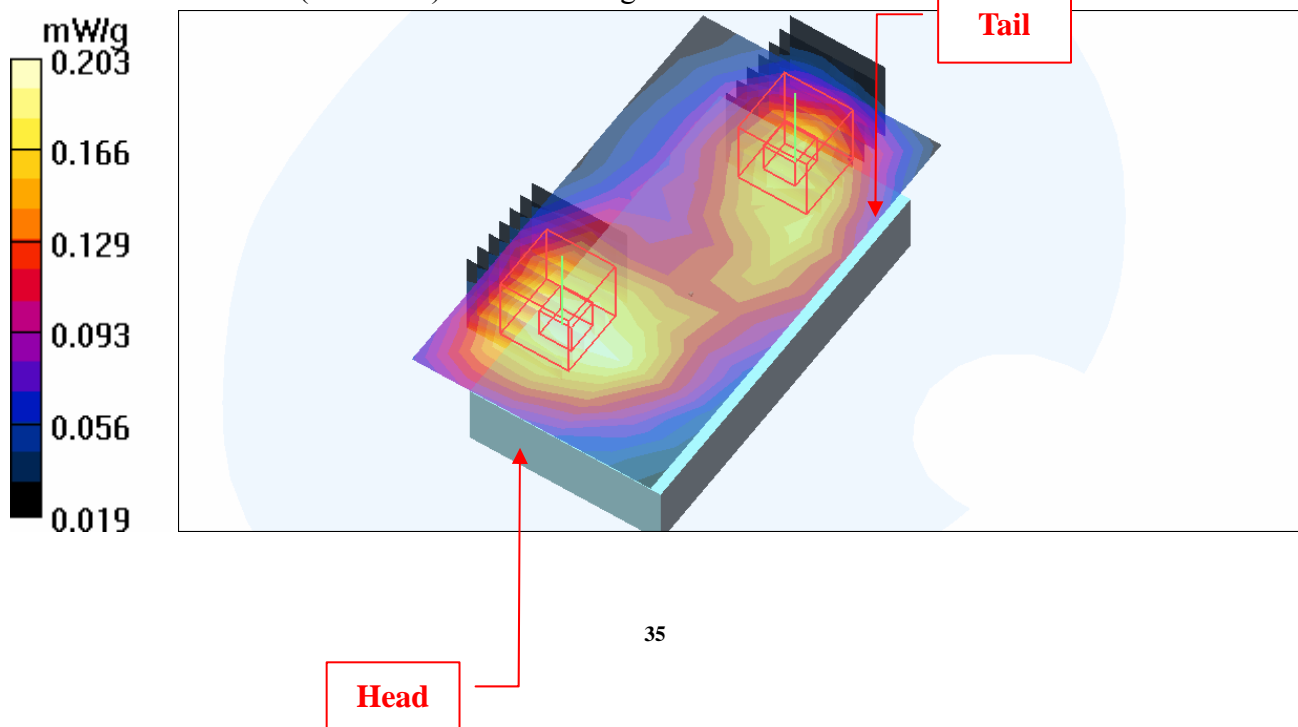

Test Laboratory: Bureau Veritas ADT

M25-Body-CDMA1900 SO32-Ch600 / Slider-on / LCD Down

DUT: Pocket PC Phone ; Type: RHOD500

Communication System: CDMA ; Frequency: 1880 MHz ; Duty Cycle: 1:1
 Medium: MSL1900 Medium parameters used: $f = 1880 \text{ MHz}$; $\sigma = 1.52 \text{ mho/m}$; $\epsilon_r = 54.5$; $\rho = 1000 \text{ kg/m}^3$
 Phantom section: Flat Section ; DUT test position : Body ; Modulation Type: OQPSK
 Separation Distance : 15 mm (The bottom side of the EUT to the Phantom)

DASY4 Configuration:

- Probe: EX3DV3 - SN3504 ; ConvF(8.21, 8.21, 8.21) ; Calibrated: 2009/1/21
- Sensor-Surface: 3mm (Mechanical Surface Detection)
- Electronics: DAE3 Sn510 ; Calibrated: 2009/1/21
- Phantom: SAM 12 ; Type: SAM V4.0; Serial: TP 1202
- Measurement SW: DASY4, V4.7 Build 80 ; Postprocessing SW: SEMCAD, V1.8 Build 186

Mid Channel 600/Area Scan (9x10x1): Measurement grid: $dx=15\text{mm}$, $dy=15\text{mm}$
 Maximum value of SAR (measured) = 0.631 mW/g

Mid Channel 600/Zoom Scan (7x7x7) (7x7x7)/Cube 0: Measurement grid: $dx=5\text{mm}$, $dy=5\text{mm}$, $dz=5\text{mm}$

Reference Value = 5.61 V/m

Peak SAR (extrapolated) = 0.818 W/kg

SAR(1 g) = 0.518 mW/g; SAR(10 g) = 0.313 mW/g

Maximum value of SAR (measured) = 0.626 mW/g

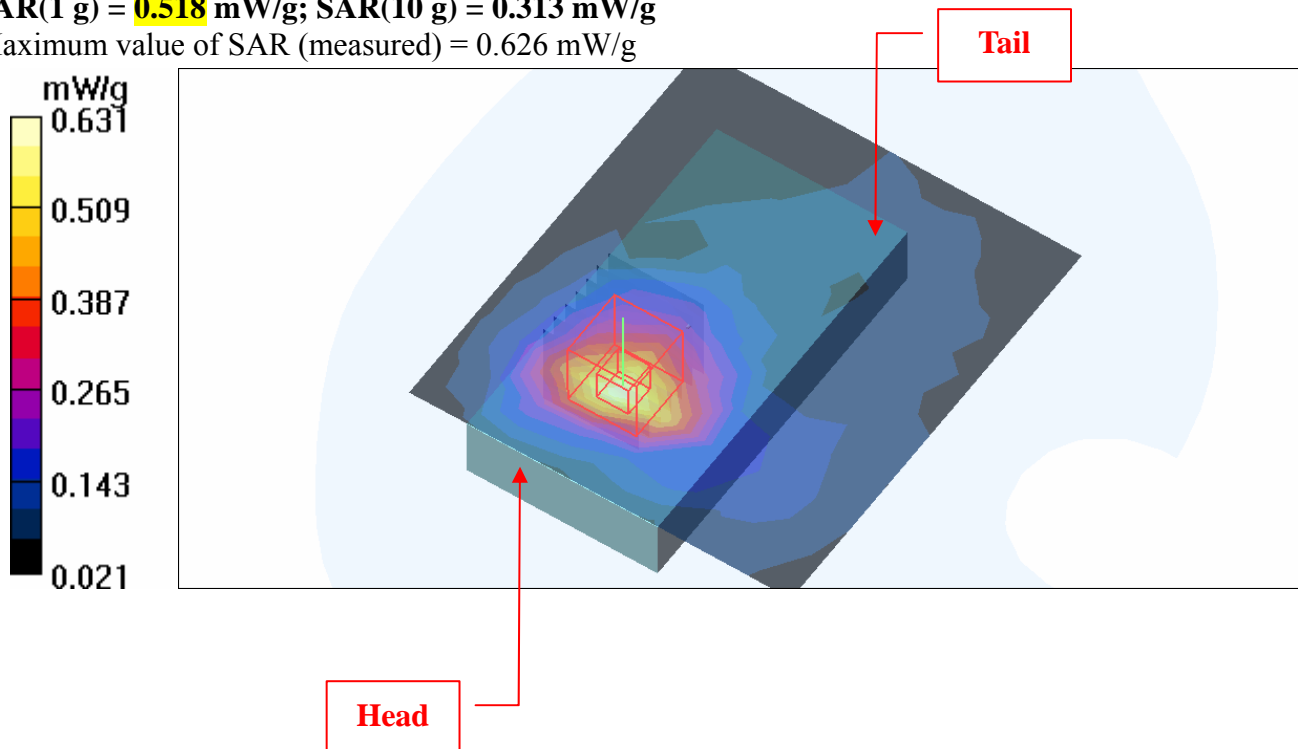

Test Laboratory: Bureau Veritas ADT

M26-Body-EVDO1900 FTAP-Ch600 / Slider-on / LCD Down**DUT: Pocket PC Phone ; Type: RHOD500**

Communication System: CDMA ; Frequency: 1880 MHz ; Duty Cycle: 1:1

Medium: MSL1900 Medium parameters used: $f = 1880$ MHz; $\sigma = 1.52$ mho/m; $\epsilon_r = 54.5$; $\rho = 1000$ kg/m³

Phantom section: Flat Section ; DUT test position : Body ; Modulation Type: HPSK

Separation Distance : 15 mm (The bottom side of the EUT to the Phantom)

DASY4 Configuration:

- Probe: EX3DV3 - SN3504 ; ConvF(8.21, 8.21, 8.21) ; Calibrated: 2009/1/21

- Sensor-Surface: 3mm (Mechanical Surface Detection)

- Electronics: DAE3 Sn510 ; Calibrated: 2009/1/21

- Phantom: SAM 12 ; Type: SAM V4.0; Serial: TP 1202

- Measurement SW: DASY4, V4.7 Build 80 ; Postprocessing SW: SEMCAD, V1.8 Build 186

Mid Channel 600/Area Scan (9x10x1): Measurement grid: dx=15mm, dy=15mm

Maximum value of SAR (measured) = 0.822 mW/g

Mid Channel 600/Zoom Scan (7x7x7) (7x7x7)/Cube 0: Measurement grid: dx=5mm, dy=5mm, dz=5mm

Reference Value = 6.88 V/m

Peak SAR (extrapolated) = 0.918 W/kg

SAR(1 g) = 0.582 mW/g; SAR(10 g) = 0.352 mW/g

Maximum value of SAR (measured) = 0.718 mW/g

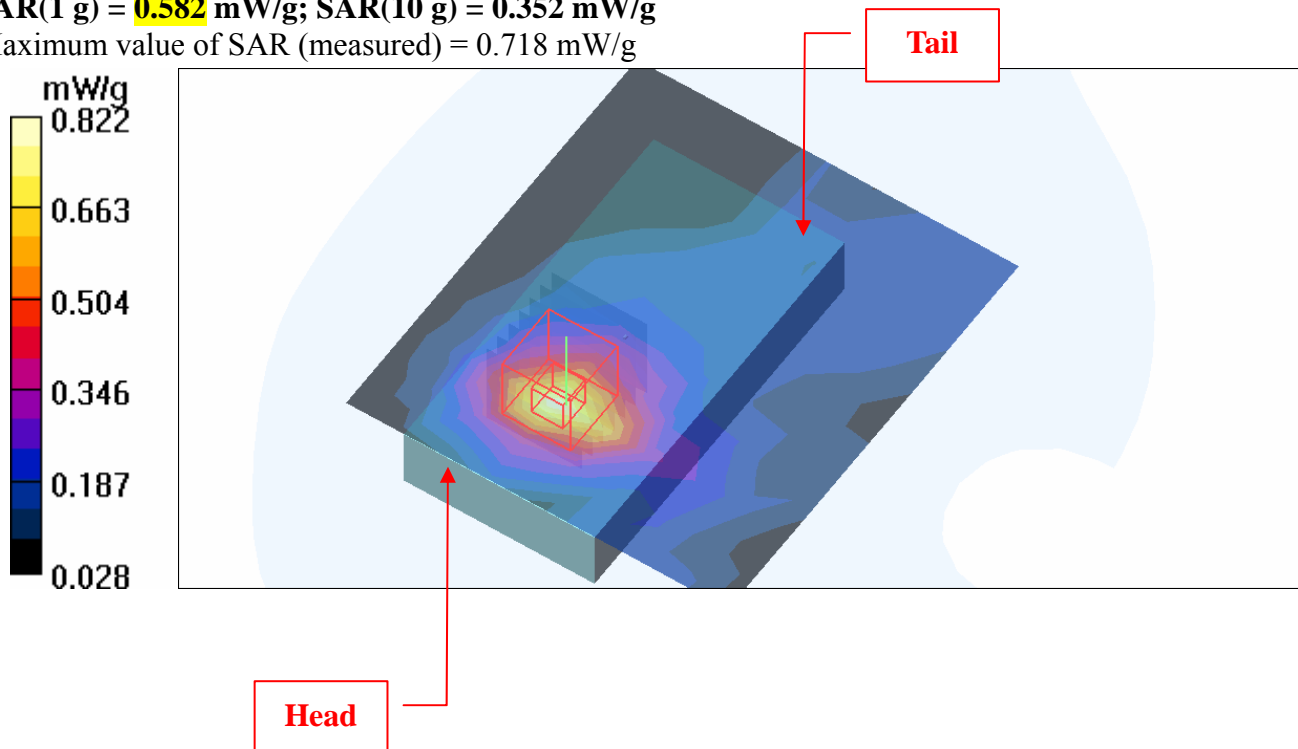

Test Laboratory: Bureau Veritas ADT

M27-Body-CDMA1900 SO32-Ch600 / Slider-on / LCD UP

DUT: Pocket PC Phone ; Type: RHOD500

Communication System: CDMA ; Frequency: 1880 MHz ; Duty Cycle: 1:1

Medium: MSL1900 Medium parameters used: $f = 1880$ MHz; $\sigma = 1.52$ mho/m; $\epsilon_r = 54.5$; $\rho = 1000$ kg/m³

Phantom section: Flat Section ; DUT test position : Body ; Modulation Type: OQPSK

Separation Distance : 15 mm (The front side of the EUT to the Phantom)

DASY4 Configuration:

- Probe: EX3DV3 - SN3504 ; ConvF(8.21, 8.21, 8.21) ; Calibrated: 2009/1/21
- Sensor-Surface: 3mm (Mechanical Surface Detection)
- Electronics: DAE3 Sn510 ; Calibrated: 2009/1/21
- Phantom: SAM 12 ; Type: SAM V4.0; Serial: TP 1202
- Measurement SW: DASY4, V4.7 Build 80 ; Postprocessing SW: SEMCAD, V1.8 Build 186

Mid Channel 600/Area Scan (6x10x1): Measurement grid: dx=15mm, dy=15mm

Maximum value of SAR (measured) = 0.250 mW/g

Mid Channel 600/Zoom Scan (7x7x7) (7x7x7)/Cube 0: Measurement grid: dx=5mm, dy=5mm, dz=5mm

Reference Value = 3.25 V/m

Peak SAR (extrapolated) = 0.314 W/kg

SAR(1 g) = 0.215 mW/g; SAR(10 g) = 0.147 mW/g

Maximum value of SAR (measured) = 0.249 mW/g

Mid Channel 600/Zoom Scan (7x7x7) (7x7x7)/Cube 1: Measurement grid: dx=5mm, dy=5mm, dz=5mm

Reference Value = 3.25 V/m

Peak SAR (extrapolated) = 0.162 W/kg

SAR(1 g) = 0.105 mW/g; SAR(10 g) = 0.082 mW/g

Maximum value of SAR (measured) = 0.121 mW/g

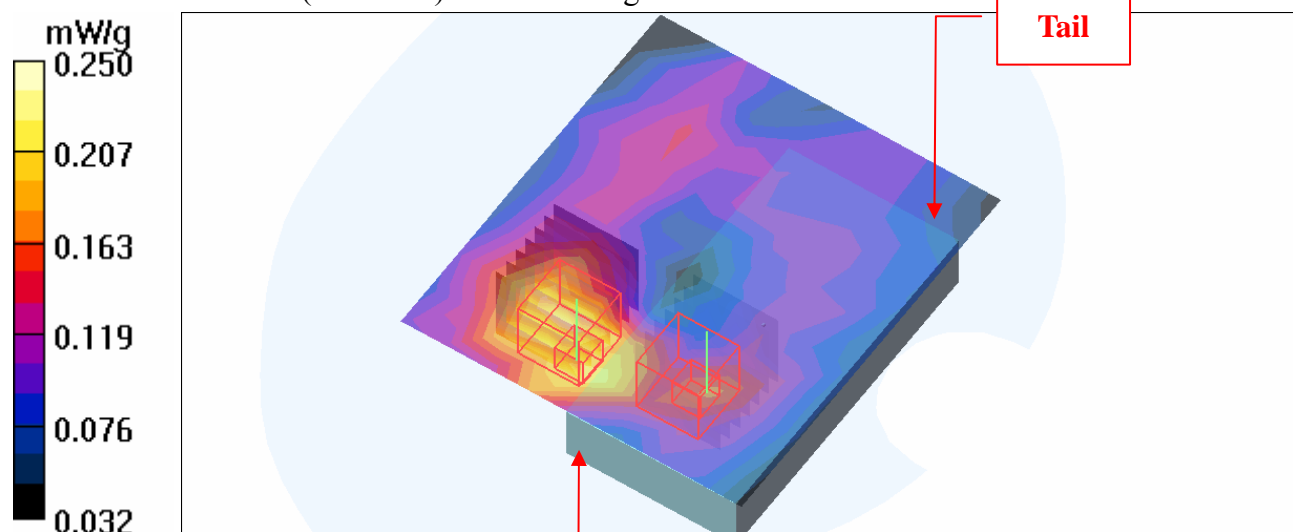

Test Laboratory: Bureau Veritas ADT

M28-Body-EVDO1900 FTAP-Ch600 / Slider-on / LCD UP

DUT: Pocket PC Phone ; Type: RHOD500

Communication System: CDMA ; Frequency: 1880 MHz ; Duty Cycle: 1:1

Medium: MSL1900 Medium parameters used: $f = 1880$ MHz; $\sigma = 1.52$ mho/m; $\epsilon_r = 54.5$; $\rho = 1000$ kg/m³

Phantom section: Flat Section ; DUT test position : Body ; Modulation Type: HPSK

Separation Distance : 15 mm (The front side of the EUT to the Phantom)

DASY4 Configuration:

- Probe: EX3DV3 - SN3504 ; ConvF(8.21, 8.21, 8.21) ; Calibrated: 2009/1/21
- Sensor-Surface: 3mm (Mechanical Surface Detection)
- Electronics: DAE3 Sn510 ; Calibrated: 2009/1/21
- Phantom: SAM 12 ; Type: SAM V4.0; Serial: TP 1202
- Measurement SW: DASY4, V4.7 Build 80 ; Postprocessing SW: SEMCAD, V1.8 Build 186

Mid Channel 600/Area Scan (6x10x1): Measurement grid: dx=15mm, dy=15mm

Maximum value of SAR (measured) = 0.241 mW/g

Mid Channel 600/Zoom Scan (7x7x7) (7x7x7)/Cube 0: Measurement grid: dx=5mm, dy=5mm, dz=5mm

Reference Value = 3.95 V/m

Peak SAR (extrapolated) = 0.318 W/kg

SAR(1 g) = 0.211 mW/g; SAR(10 g) = 0.141 mW/g

Maximum value of SAR (measured) = 0.243 mW/g

Mid Channel 600/Zoom Scan (7x7x7) (7x7x7)/Cube 1: Measurement grid: dx=5mm, dy=5mm, dz=5mm

Reference Value = 3.95 V/m

Peak SAR (extrapolated) = 0.281 W/kg

SAR(1 g) = 0.103 mW/g; SAR(10 g) = 0.083 mW/g

Maximum value of SAR (measured) = 0.125 mW/g

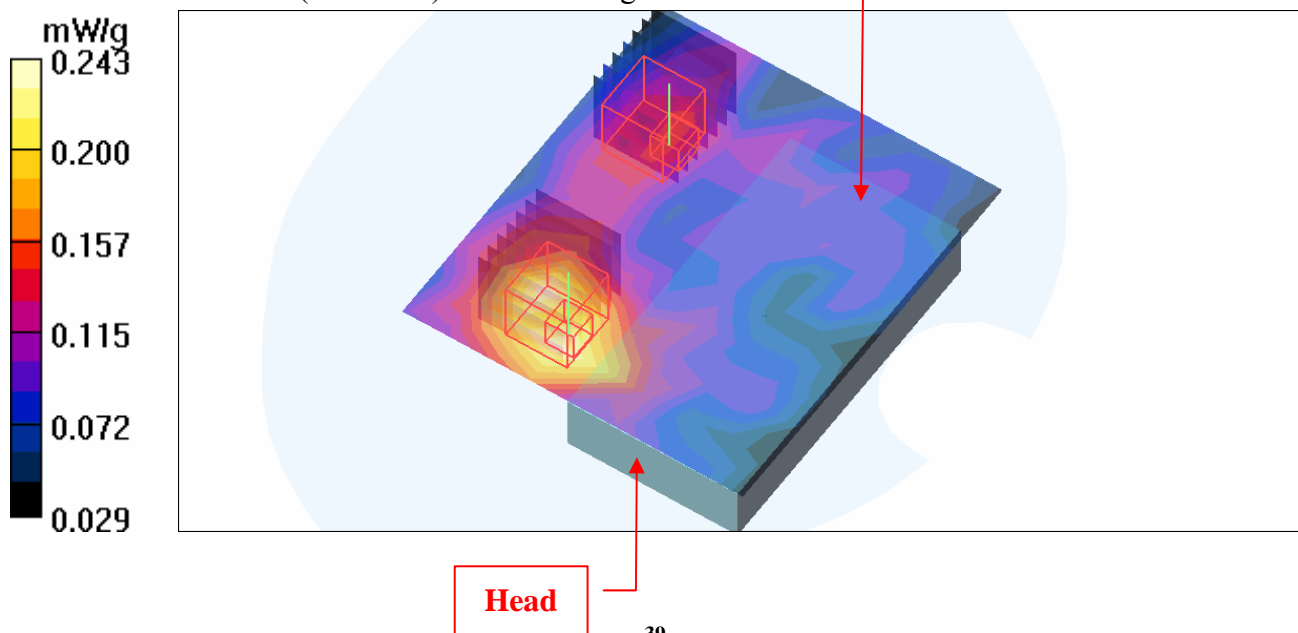

Test Laboratory: Bureau Veritas ADT

System Validation Check-HSL 835MHz

DUT: Dipole 850 MHz ; Type: D835V2 ; Serial: 4d021 ; Test Frequency: 835 MHz

Communication System: CW ; Frequency: 835 MHz; Duty Cycle: 1:1; Modulation type: CW
Medium: HSL835; Medium parameters used: $f = 835$ MHz; $\sigma = 0.9$ mho/m; $\epsilon_r = 42.9$; $\rho = 1000$ kg/m³ ;
Liquid level : 150 mm
Phantom section: Flat Section ; Separation distance : 15 mm (The feetpoint of the dipole to the Phantom)
Air temp. : 22.3 degrees ; Liquid temp. : 21.5 degrees

DASY4 Configuration:

- Probe: EX3DV3 - SN3504 ; ConvF(9.57, 9.57, 9.57) ; Calibrated: 2009/1/21
- Sensor-Surface: 3mm (Mechanical Surface Detection)
- Electronics: DAE3 Sn510 ; Calibrated: 2009/1/21
- Phantom: SAM 12; Type: SAM V4.0; Serial: TP 1202
- Measurement SW: DASY4, V4.7 Build 80; Postprocessing SW: SEMCAD, V1.8 Build 186

d=15mm, Pin=250mW/Area Scan (7x9x1): Measurement grid: dx=15mm, dy=15mm
Maximum value of SAR (measured) = 2.56 mW/g

d=15mm, Pin=250mW/Zoom Scan (7x7x7) (7x7x7)/Cube 0: Measurement grid: dx=5mm, dy=5mm, dz=5mm

Reference Value = 55.3 V/m; Power Drift = -0.103 dB

Peak SAR (extrapolated) = 3.35 W/kg

SAR(1 g) = 2.37 mW/g; SAR(10 g) = 1.54 mW/g

Maximum value of SAR (measured) = 2.74 mW/g

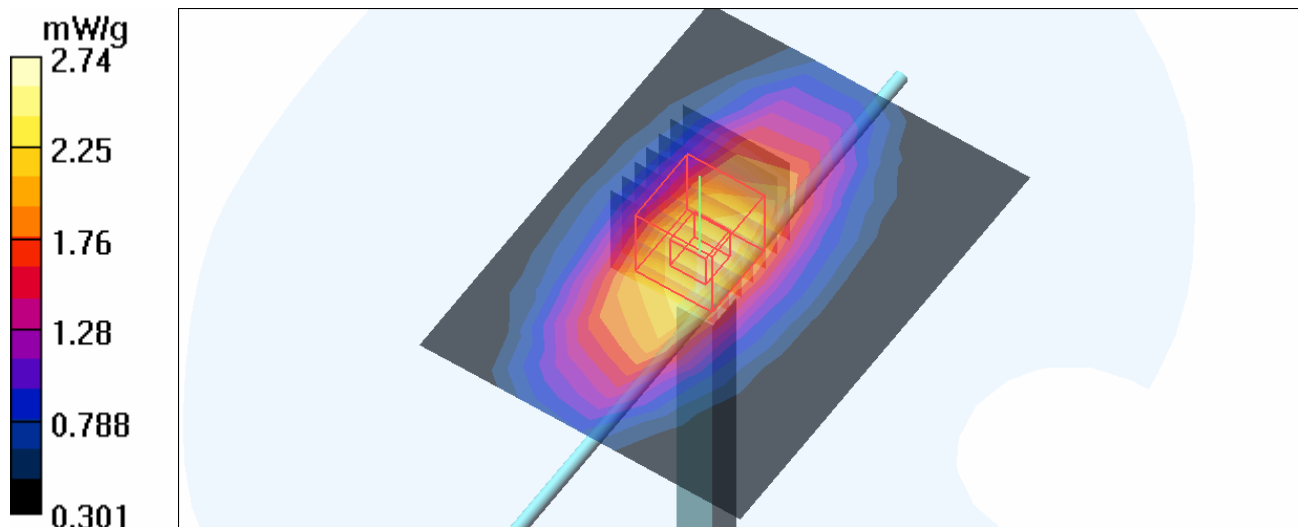

Test Laboratory: Bureau Veritas ADT

System Validation Check-MSL 835MHz

DUT: Dipole 850 MHz ; Type: D835V2 ; Serial: 4d021 ; Test Frequency: 835 MHz

Communication System: CW ; Frequency: 835 MHz; Duty Cycle: 1:1; Modulation type: CW
Medium: MSL835; Medium parameters used: $f = 835$ MHz; $\sigma = 0.98$ mho/m; $\epsilon_r = 55.9$; $\rho = 1000$ kg/m³ ;
Liquid level : 151 mm
Phantom section: Flat Section ; Separation distance : 15 mm (The feetpoint of the dipole to the Phantom)
Air temp. : 22.7 degrees ; Liquid temp. : 21.6 degrees

DASY4 Configuration:

- Probe: EX3DV3 - SN3504 ; ConvF(9.71, 9.71, 9.71) ; Calibrated: 2009/1/21
- Sensor-Surface: 3mm (Mechanical Surface Detection)
- Electronics: DAE3 Sn510 ; Calibrated: 2009/1/21
- Phantom: SAM 12; Type: SAM V4.0; Serial: TP 1202
- Measurement SW: DASY4, V4.7 Build 80 ; Postprocessing SW: SEMCAD, V1.8 Build 186

d=15mm, Pin=250mW/Area Scan (7x9x1): Measurement grid: dx=15mm, dy=15mm
Maximum value of SAR (measured) = 2.54 mW/g

d=15mm, Pin=250mW/Zoom Scan (7x7x7) (7x7x7)/Cube 0: Measurement grid: dx=5mm, dy=5mm, dz=5mm

Reference Value = 53.0 V/m; Power Drift = -0.076 dB

Peak SAR (extrapolated) = 3.49 W/kg

SAR(1 g) = 2.37 mW/g; SAR(10 g) = 1.54 mW/g

Maximum value of SAR (measured) = 2.73 mW/g

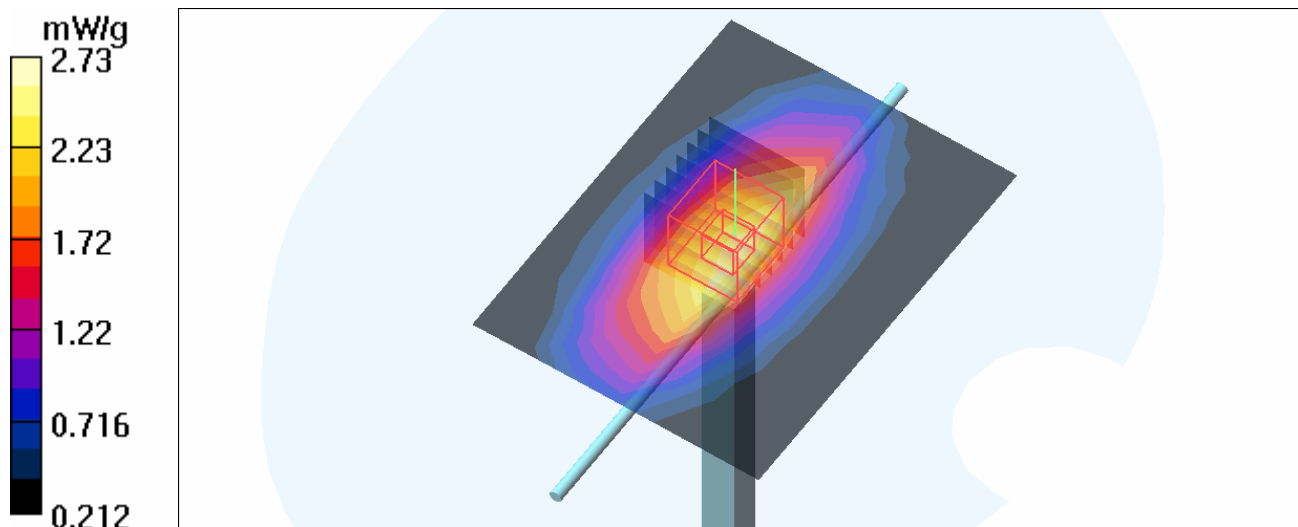

Test Laboratory: Bureau Veritas ADT

System Validation Check-HSL 1900MHz

DUT: Dipole 1900 MHz ; Type: D1900V2 ; Serial: 5d036 ; Test Frequency: 1900 MHz

Communication System: CW ; Frequency: 1900 MHz; Duty Cycle: 1:1; Modulation type: CW
Medium: HSL1900; Medium parameters used: $f = 1900$ MHz; $\sigma = 1.42$ mho/m; $\epsilon_r = 40.5$; $\rho = 1000$ kg/m³ ;
Liquid level : 150 mm
Phantom section: Flat Section ; Separation distance : 10 mm (The feetpoint of the dipole to the Phantom)
Air temp. : 22.9 degrees ; Liquid temp. : 21.8 degrees

DASY4 Configuration:

- Probe: EX3DV3 - SN3504 ; ConvF(8.08, 8.08, 8.08) ; Calibrated: 2009/1/21
- Sensor-Surface: 3mm (Mechanical Surface Detection)
- Electronics: DAE3 Sn510 ; Calibrated: 2009/1/21
- Phantom: SAM 12; Type: SAM V4.0; Serial: TP 1202
- Measurement SW: DASY4, V4.7 Build 80 ; Postprocessing SW: SEMCAD, V1.8 Build 186

d=10mm, Pin=250mW/Area Scan (7x7x1): Measurement grid: dx=15mm, dy=15mm
Maximum value of SAR (measured) = 13.1 mW/g

d=10mm, Pin=250mW/Zoom Scan (7x7x7) (7x7x7)/Cube 0: Measurement grid: dx=5mm, dy=5mm, dz=5mm

Reference Value = 92.2 V/m; Power Drift = -0.016 dB

Peak SAR (extrapolated) = 19.7 W/kg

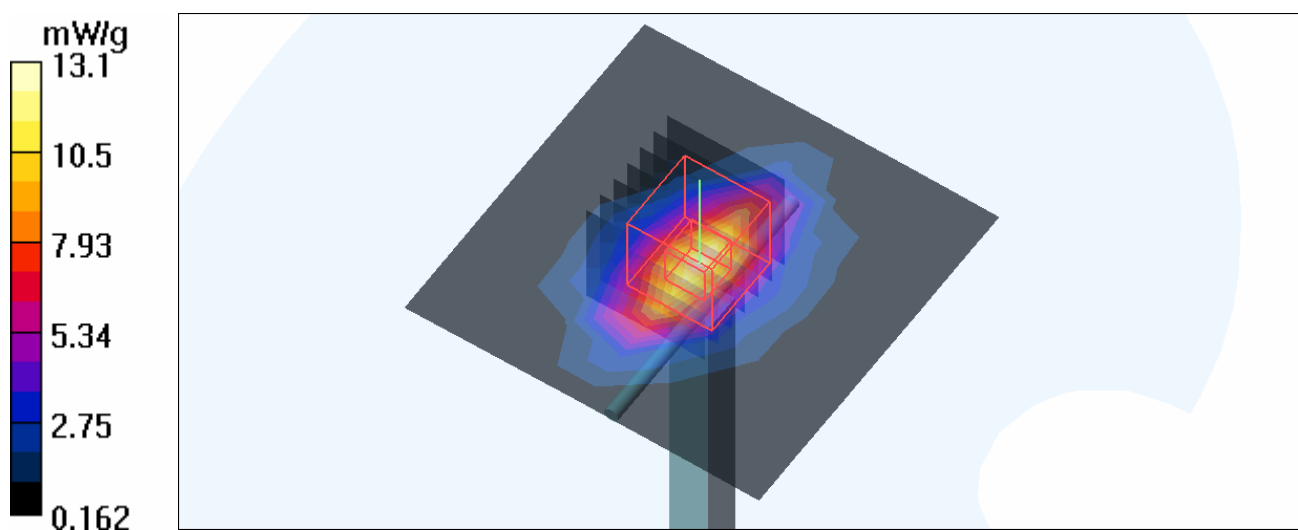
SAR(1 g) = **10.1 mW/g**; SAR(10 g) = **5.14 mW/g**

Test Laboratory: Bureau Veritas ADT

System Validation Check-MSL 1900MHz

DUT: Dipole 1900 MHz ; Type: D1900V2 ; Serial: 5d036 ; Test Frequency: 1900 MHz

Communication System: CW ; Frequency: 1900 MHz; Duty Cycle: 1:1; Modulation type: CW
Medium: MSL1900; Medium parameters used: $f = 1900$ MHz; $\sigma = 1.54$ mho/m; $\epsilon_r = 54.4$; $\rho = 1000$ kg/m³ ; Liquid level : 155 mm
Phantom section: Flat Section ; Separation distance : 10 mm (The feetpoint of the dipole to the Phantom) Air temp. : 22.7 degrees ; Liquid temp. : 21.5 degrees

DASY4 Configuration:

- Probe: EX3DV3 - SN3504 ; ConvF(8.21, 8.21, 8.21) ; Calibrated: 2009/1/21
- Sensor-Surface: 3mm (Mechanical Surface Detection)
- Electronics: DAE3 Sn510 ; Calibrated: 2009/1/21
- Phantom: SAM 12; Type: SAM V4.0; Serial: TP 1202
- Measurement SW: DASY4, V4.7 Build 80 ; Postprocessing SW: SEMCAD, V1.8 Build 186

d=10mm, Pin=250mW/Area Scan (7x7x1): Measurement grid: dx=15mm, dy=15mm
Maximum value of SAR (measured) = 13.5 mW/g

d=10mm, Pin=250mW/Zoom Scan (7x7x7) (7x7x7)/Cube 0: Measurement grid: dx=5mm, dy=5mm, dz=5mm

Reference Value = 94.1 V/m; Power Drift = -0.036 dB

Peak SAR (extrapolated) = 16.4 W/kg

SAR(1 g) = 9.65 mW/g; SAR(10 g) = 5.06 mW/g

Maximum value of SAR (measured) = 13.3 mW/g

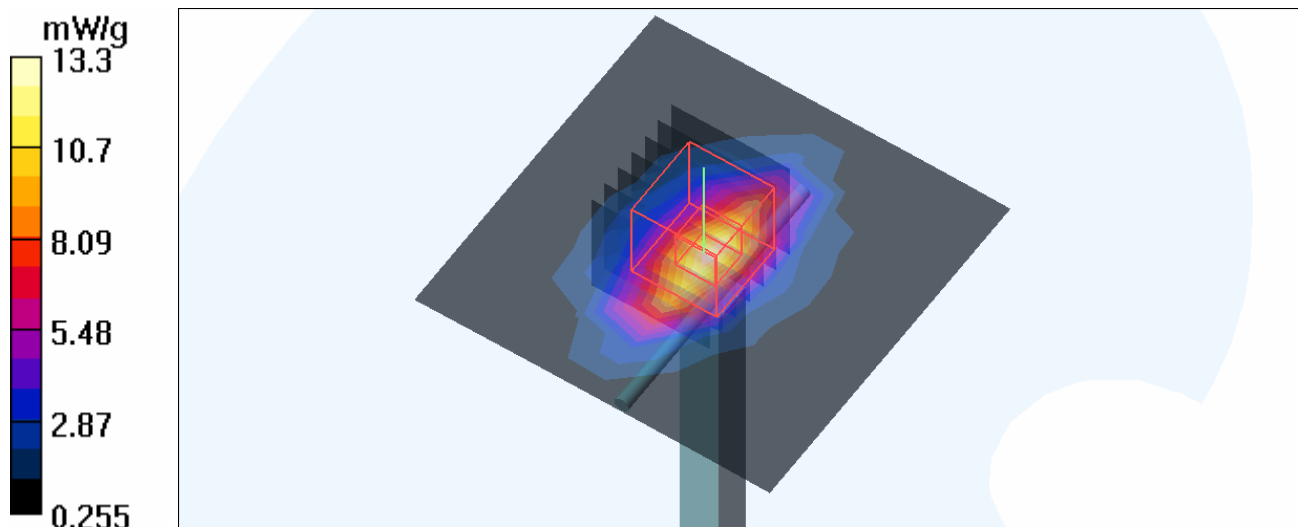

APPENDIX B: ADT SAR MEASUREMENT SYSTEM



APPENDIX C: PHOTOGRAPHS OF SYSTEM VALIDATION

