



FCC TEST REPORT (PART 27)

REPORT NO.: RF121129C10-2
MODEL NO.: PN07120
FCC ID: NM8PN07120
RECEIVED: Nov. 29, 2012
TESTED: Jan. 03 ~ Jan. 22, 2013
ISSUED: Jan. 31, 2013

APPLICANT: HTC Corporation

ADDRESS: 23, Xinghua Rd., Taoyuan 330, Taiwan, R.O.C.

ISSUED BY: Bureau Veritas Consumer Products Services
(H.K.) Ltd., Taoyuan Branch

LAB ADDRESS: No. 47, 14th Ling, Chia Pau Vil., Lin Kou Dist.,
New Taipei City, Taiwan, R.O.C.

TEST LOCATION: No. 19, Hwa Ya 2nd Rd, Wen Hwa Tsuen, Kwei
Shan Hsiang, Taoyuan Hsien 333, Taiwan, R.O.C.

This report should not be used by the client to claim product certification, approval, or endorsement by TAF or any government agencies.



This report is for your exclusive use. Any copying or replication of this report to or for any other person or entity, or use of our name or trademark, is permitted only with our prior written permission. This report sets forth our findings solely with respect to the test samples identified herein. The results set forth in this report are not indicative or representative of the quality or characteristics of the lot from which a test sample was taken or any similar or identical product unless specifically and expressly noted. Our report includes all of the tests requested by you and the results thereof based upon the information that you provided to us. You have 60 days from date of issuance of this report to notify us of any material error or omission caused by our negligence, provided, however, that such notice shall be in writing and shall specifically address the issue you wish to raise. A failure to raise such issue within the prescribed time shall constitute your unqualified acceptance of the completeness of this report, the tests conducted and the correctness of the report contents. Unless specifically mentioned, the uncertainty of measurement has been explicitly taken into account to declare the compliance or non-compliance to the specification.

TABLE OF CONTENTS

RELEASE CONTROL RECORD	4
1 CERTIFICATION	5
2 SUMMARY OF TEST RESULTS	6
2.1 MEASUREMENT UNCERTAINTY	7
2.2 TEST SITE AND INSTRUMENTS	8
3 GENERAL INFORMATION	9
3.1 GENERAL DESCRIPTION OF EUT	9
3.2 CONFIGURATION OF SYSTEM UNDER TEST	10
3.3 DESCRIPTION OF SUPPORT UNITS	11
3.4 DESCRIPTION OF TEST MODES	12
3.5 GENERAL DESCRIPTION OF APPLIED STANDARDS	14
4 TEST TYPES AND RESULTS	15
4.1 OUTPUT POWER MEASUREMENT	15
4.1.1 LIMITS OF OUTPUT POWER MEASUREMENT	15
4.1.2 TEST PROCEDURES	15
4.1.3 TEST SETUP	16
4.1.4 TEST RESULTS	17
4.2 FREQUENCY STABILITY MEASUREMENT	24
4.2.1 LIMITS OF FREQUENCY STABILITY MEASUREMENT	24
4.2.2 TEST PROCEDURE	24
4.2.3 TEST SETUP	24
4.2.4 TEST RESULTS	25
4.3 OCCUPIED BANDWIDTH MEASUREMENT	27
4.3.1 LIMITS OF OCCUPIED BANDWIDTH MEASUREMENT	27
4.3.2 TEST SETUP	27
4.3.3 TEST PROCEDURES	27
4.3.4 TEST RESULTS	28
4.4 PEAK TO AVERAGE RATIO	32
4.4.1 LIMITS OF PEAK TO AVERAGE RATIO MEASUREMENT	32
4.4.2 TEST SETUP	32
4.4.3 TEST PROCEDURES	32
4.4.4 TEST RESULTS	33
4.5 BAND EDGE MEASUREMENT	37
4.5.1 LIMITS OF BAND EDGE MEASUREMENT	37
4.5.2 TEST SETUP	37
4.5.3 TEST PROCEDURES	38
4.5.4 TEST RESULTS	39
4.6 CONDUCTED SPURIOUS EMISSIONS	47



A D T

4.6.1	LIMITS OF CONDUCTED SPURIOUS EMISSIONS MEASUREMENT	47
4.6.2	TEST PROCEDURE	47
4.6.3	TEST SETUP.....	47
4.6.4	TEST RESULTS	48
4.7	RADIATED EMISSION MEASUREMENT	50
4.7.1	LIMITS OF RADIATED EMISSION MEASUREMENT	50
4.7.2	TEST PROCEDURES.....	50
4.7.3	DEVIATION FROM TEST STANDARD	50
4.7.4	TEST SETUP.....	51
4.7.5	TEST RESULTS	52
5	INFORMATION ON THE TESTING LABORATORIES	64
6	APPENDIX A – MODIFICATIONS RECORDERS FOR ENGINEERING CHANGES TO THE EUT BY THE LAB	65



A D T

RELEASE CONTROL RECORD

ISSUE NO.	REASON FOR CHANGE	DATE ISSUED
RF121129C10-2	Original release	Jan. 31, 2013



1 CERTIFICATION

PRODUCT: Smartphone
MODEL NO.: PN07120
BRAND: HTC
APPLICANT: HTC Corporation
TESTED: Jan. 03 ~ Jan. 22, 2013
TEST SAMPLE: Production Unit
TEST STANDARDS: **FCC Part 27, Subpart C, L**
FCC Part 2
ANSI C63.4-2003

The above equipment (model: PN07120) has been tested by **Bureau Veritas Consumer Products Services (H.K.) Ltd., Taoyuan Branch**, and found compliance with the requirement of the above standards. The test record, data evaluation & Equipment Under Test (EUT) configurations represented herein are true and accurate accounts of the measurements of the sample's EMC characteristics under the conditions specified in this report.

PREPARED BY : Evonne Liu , **DATE:** Jan. 31, 2013
Evonne Liu / Specialist

APPROVED BY : Anderson Chiu , **DATE:** Jan. 31, 2013
Anderson Chiu / Senior Engineer

2 SUMMARY OF TEST RESULTS

The EUT has been tested according to the following specifications:

OPERATING BAND: 704–716 MHz			
STANDARD SECTION	TEST TYPE AND LIMIT	RESULT	REMARK
2.1046 27.50(C)(10)	Maximum Peak Output Power	PASS	Meet the requirement of limit.
2.1055 27.54	Frequency Stability	PASS	Meet the requirement of limit.
2.1049 27.53(g)	Occupied Bandwidth	PASS	Meet the requirement of limit.
27.50(d)(5)	Peak to average ratio	PASS	Meet the requirement of limit.
27.53(g)	Band Edge Measurements	PASS	Meet the requirement of limit.
2.1051 27.53(g)	Conducted Spurious Emissions	PASS	Meet the requirement of limit.
2.1053 27.53(g)	Radiated Spurious Emissions	PASS	Meet the requirement of limit. Minimum passing margin is -11.65dB at 1420.00MHz.

OPERATING BAND: 1710~1755 MHz			
STANDARD SECTION	TEST TYPE AND LIMIT	RESULT	REMARK
2.1046 27.50(d)(4)	Maximum Peak Output Power	PASS	Meet the requirement of limit.
2.1055 27.54	Frequency Stability	PASS	Meet the requirement of limit.
2.1049 27.53(h)	Occupied Bandwidth	PASS	Meet the requirement of limit.
27.50(d)(5)	Peak to average ratio	PASS	Meet the requirement of limit.
27.53(h)	Band Edge Measurements	PASS	Meet the requirement of limit.
2.1051 27.53(h)	Conducted Spurious Emissions	PASS	Meet the requirement of limit.
2.1053 27.53(h)	Radiated Spurious Emissions	PASS	Meet the requirement of limit. Minimum passing margin is -21.19dB at 30.00MHz.

2.1 MEASUREMENT UNCERTAINTY

Where relevant, the following measurement uncertainty levels have been estimated for tests performed on the EUT as specified in CISPR 16-4-2:

MEASUREMENT	FREQUENCY	UNCERTAINTY
Conducted emissions	150kHz~30MHz	2.44 dB
Radiated emissions	30MHz ~ 200MHz	2.93 dB
	200MHz ~1000MHz	2.95 dB
	1GHz ~ 18GHz	2.26 dB
	18GHz ~ 40GHz	1.94 dB

This uncertainty represents an expanded uncertainty expressed at approximately the 95% confidence level using a coverage factor of k=2.

2.2 TEST SITE AND INSTRUMENTS

DESCRIPTION & MANUFACTURER	MODEL NO.	SERIAL NO.	DATE OF CALIBRATION	DUE DATE OF CALIBRATION
Test Receiver ROHDE & SCHWARZ	ESCI	100744	Apr. 19, 2012	Apr. 18, 2013
Spectrum Analyzer ROHDE & SCHWARZ	FSU43	101261	Dec. 17, 2012	Dec. 16, 2013
BILOG Antenna SCHWARZBECK	VULB9168	9168-472	Apr. 03, 2012	Apr. 02, 2013
HORN Antenna SCHWARZBECK	BBHA 9120 D	209	Sep. 03, 2012	Sep. 02, 2013
HORN Antenna SCHWARZBECK	BBHA 9170	BBHA9170153	Jan. 17, 2012	Jan. 16, 2013
HORN Antenna SCHWARZBECK	BBHA 9170	9170-480	Dec. 25, 2012	Dec. 24, 2013
Preamplifier EMCI	EMC 012645	980115	Dec. 28, 2012	Dec. 27, 2013
Preamplifier EMCI	EMC 330H	980112	Dec. 28, 2012	Dec. 27, 2013
RF signal cable HUBER+SUHNNER	SUCOFLEX 104	309219/4	Oct. 19, 2012	Oct. 18, 2013
RF signal cable HUBER+SUHNNER	SUCOFLEX 104	250130/4	Oct. 19, 2012	Oct. 18, 2013
RF signal cable Worken	RG-213	NA	Dec. 29, 2012	Dec. 28, 2013
Software	E3 6.120103	NA	NA	NA
Antenna Tower MF	MFA-440H	NA	NA	NA
Turn Table MF	MFT-201SS	NA	NA	NA
Antenna Tower & Turn Table Controller MF	MF-7802	NA	NA	NA
Mini-Circuits Power Splitter	ZN2PD-9G	NA	Mar. 23, 2012	Mar. 22, 2013
JFW 20dB attenuation	50HF-020-SMA	NA	NA	NA
Communications Tester-Wireless	E5515C	MY52102049	Jun. 11, 2012	Jun. 10, 2013
Radio Communication Analyzer	MT8820C	6201168830	Jul. 17, 2012	Jul. 16, 2013

NOTE: 1. The calibration interval of the above test instruments is 12 months and the calibrations are traceable to NML/ROC and NIST/USA.

2. The test was performed in HwaYa Chamber 9.
3. The horn antenna and HP preamplifier (model: 8449B) are used only for the measurement of emission frequency above 1GHz if tested.
4. The FCC Site Registration No. is 460141.
5. The IC Site Registration No. is IC 7450F-4.

3 GENERAL INFORMATION

3.1 GENERAL DESCRIPTION OF EUT

PRODUCT	Smartphone	
MODEL NO.	PN07120	
POWER SUPPLY	5Vdc (adapter or host equipment) 3.75Vdc (battery)	
MODULATION TECHNOLOGY	LTE Band 17	QPSK, 16QAM
	LTE Band 4	QPSK, 16QAM
FREQUENCY RANGE	LTE Band 17 Channel Bandwidth: 5MHz	706.5MHz ~ 713.5MHz
	LTE Band 17 Channel Bandwidth: 10MHz	709MHz ~ 711MHz
	LTE Band 4 Channel Bandwidth: 5MHz	1712.5MHz ~1752.5MHz
	LTE Band 4 Channel Bandwidth: 10MHz	1715.0MHz ~1750.0MHz
EMISSION DESIGNATOR	LTE Band 17 Channel Bandwidth: 5MHz	4M50G7D
	LTE Band 17 Channel Bandwidth: 10MHz	8M94G7D
	LTE Band 4 Channel Bandwidth: 5MHz	4M50G7D
	LTE Band 4 Channel Bandwidth: 10MHz	8M93G7D
MAX. ERP POWER (W)	LTE Band 17 Channel Bandwidth: 10MHz	35.65mW
	LTE Band 4 Channel Bandwidth: 10MHz	111.69mW
CATEGORY	3	
ANTENNA TYPE	Fixed Internal Antenna	
DATA CABLE	Refer to Note as below	
I/O PORTS	Refer to users' manual	
ACCESSORY DEVICES	Refer to Note as below	

NOTE:

1. The EUT's accessories list refers to Ext Pho.pdf.
2. The device has 2 configurations as below.
Main Sample (A): Battery 1 + LCD Panel 1+ Front Camera 1
2nd Sample (B): Battery 2 + LCD Panel 2+ Front Camera 2
3. The above EUT information is declared by manufacturer and for more detailed features description, please refer to the manufacturer's specifications or User's Manual.

3.2 CONFIGURATION OF SYSTEM UNDER TEST

<For Radiated Emission Test>

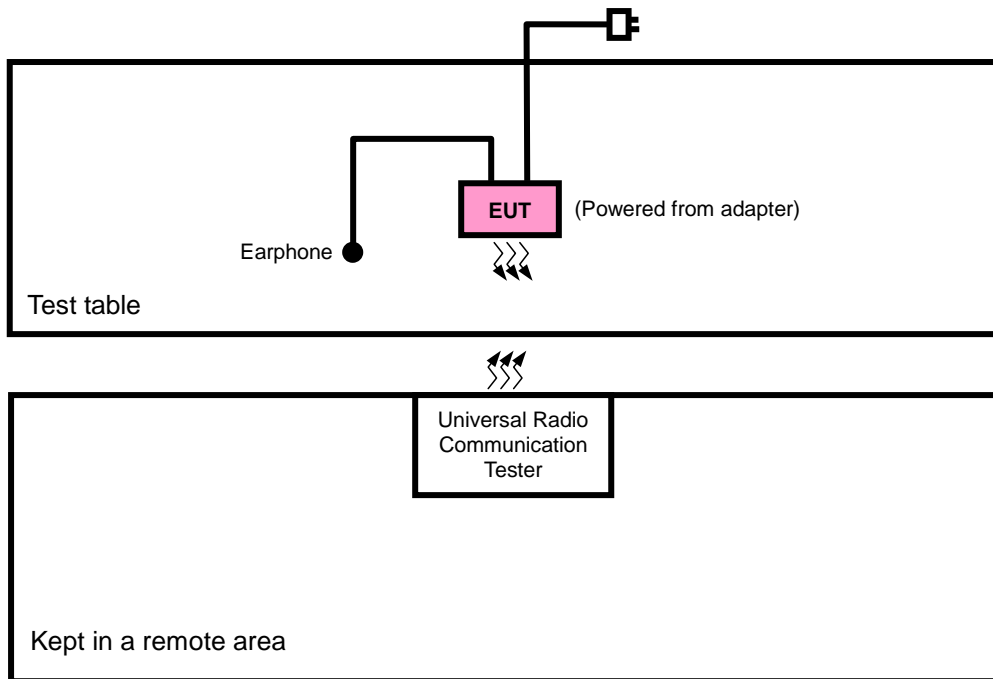

<For Output Power Test>

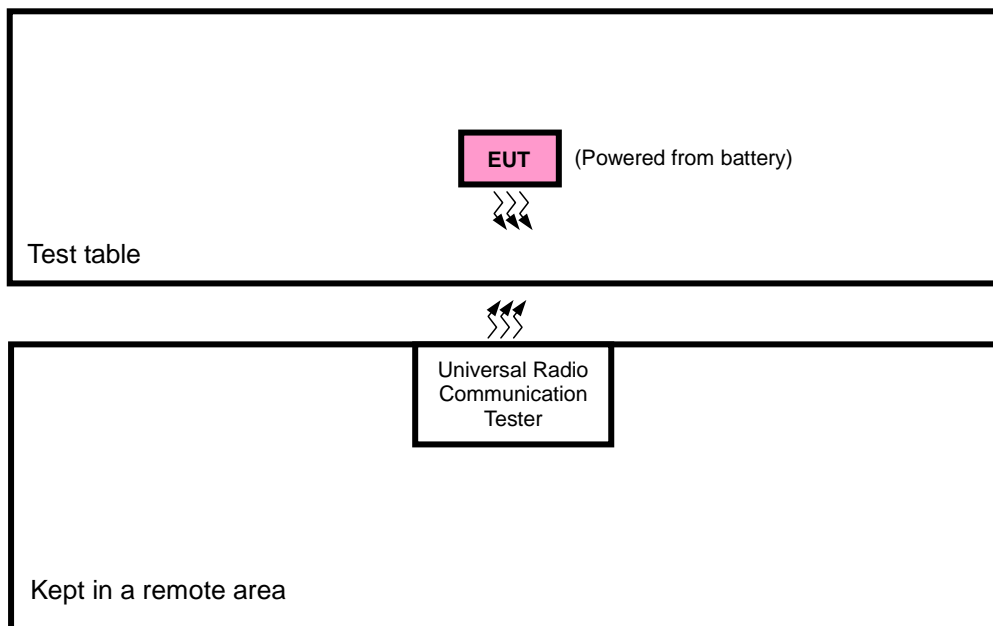

3.3 DESCRIPTION OF SUPPORT UNITS

The EUT has been tested as an independent unit together with other necessary accessories or support units. The following support units or accessories were used to form a representative test configuration during the tests.

NO.	PRODUCT	BRAND	MODEL NO.	SERIAL NO.	FCC ID
1	Earphone	Merry	Max 300	NA	NA
2	Earphone	Cotron	Max 300	NA	NA

NO.	SIGNAL CABLE DESCRIPTION OF THE ABOVE SUPPORT UNITS
1	1.1m audio cable
2	1.1m audio cable

NOTE:

1. All power cords of the above support units are non shielded (1.8m).
2. Item 1 and 2 was provided by client.

3.4 DESCRIPTION OF TEST MODES

Pre-Scan has been conducted to determine the worst-case mode from all possible combinations between available modulations, data rates, XYZ axis and antenna ports. The worst case was found when positioned on Y-plane for ERP and Y-axis for radiated emission. Following channel(s) was (were) selected for the final test as listed below:

EUT CONFIGURE MODE	TEST ITEM
A	Main Sample
B	2 nd Sample

LTE Band 17

EUT CONFIGURE MODE	Tx Antenna Status	TEST ITEM	AVAILABLE CHANNEL	TESTED CHANNEL	CHANNEL BANDWIDTH	MODULATION	MODE
A	0, 1	ERP	23780 to 23800	23780, 23790, 23800	10MHz	QPSK	1 RB / 24 RB Offset
							1 RB / 49 RB Offset
B	0	ERP	23780 to 23800	23780, 23790, 23800	10MHz	QPSK	1 RB / 24 RB Offset
A	0, 1	FREQUENCY STABILITY	23755 to 23825	23790	5MHz	QPSK	1 RB / 12 RB Offset
			23780 to 23800	23790	10MHz	QPSK	1 RB / 24 RB Offset
A	0, 1	OCCUPIED BANDWIDTH	23755 to 23825	23790	5MHz	QPSK, 16QAM	25 RB / 0 RB Offset
			23780 to 23800	23790	10MHz	QPSK, 16QAM	50 RB / 0 RB Offset
A	0, 1	PEAK TO AVERAGE RATIO	23755 to 23825	23755, 23790, 23825	5MHz	QPSK	1 RB / 12 RB Offset
						16QAM	1 RB / 24 RB Offset
			23780 to 23800	23780, 23790, 23800	10MHz	QPSK	1 RB / 0 RB Offset
						16QAM	1 RB / 24 RB Offset
A	0, 1	BAND EDGE	23755 to 23825	23755, 23825	5MHz	QPSK	1 RB / 0 RB Offset
							1 RB / 24 RB Offset
							25 RB / 0 RB Offset
			23780 to 23800	23780, 23800	10MHz	QPSK	1 RB / 0 RB Offset
							1 RB / 49 RB Offset
							50 RB / 0 RB Offset
A	0, 1	CONDUCTED EMISSION	23755 to 23825	23790	5MHz	QPSK	1 RB / 12 RB Offset
			23780 to 23800	23790	10MHz	QPSK	1 RB / 0 RB Offset
A	0, 1	RADIATED EMISSION	23780 to 23800	23790	10MHz	QPSK	1 RB / 24 RB Offset
							1 RB / 49 RB Offset
B	0	RADIATED EMISSION	23780 to 23800	23790	10MHz	QPSK	1 RB / 24 RB Offset

Note: This device was tested under all bandwidths, RB configurations and modulations. The worst case were found in QPSK modulation.



A D T

LTE Band 4

EUT CONFIGURE MODE	Tx Antenna Status	TEST ITEM	AVAILABLE CHANNEL	TESTED CHANNEL	CHANNEL BANDWIDTH	MODULATION	MODE
A	0, 1	EIRP	20000 to 20350	20000, 20175, 20350	10MHz	QPSK	1 RB / 24 RB Offset
							1 RB / 0 RB Offset
B	0	EIRP	20000 to 20350	20000, 20175, 20350	10MHz	QPSK	1 RB / 24 RB Offset
A	0, 1	FREQUENCY STABILITY	19975 to 20375	20175	5MHz	QPSK	1 RB / 12 RB Offset
			20000 to 20350	20175	10MHz	QPSK	1 RB / 24 RB Offset
A	0, 1	OCCUPIED BANDWIDTH	19975 to 20375	20175	5MHz	QPSK, 16QAM	25 RB / 0 RB Offset
			20000 to 20350	20175	10MHz	QPSK, 16QAM	50 RB / 0 RB Offset
A	0, 1	PEAK TO AVERAGE RATIO	19975 to 20375	19975, 20175, 20375	5MHz	QPSK, 16QAM	1 RB / 12 RB Offset
			20000 to 20350	20000, 20175, 20350	10MHz	QPSK, 16QAM	1 RB / 24 RB Offset
A	0, 1	BAND EDGE	19975 to 20375	19975, 20375	5MHz	QPSK	1 RB / 0 RB Offset
							1 RB / 24 RB Offset
							25 RB / 0 RB Offset
			20000 to 20350	20000, 20350	10MHz	QPSK	1 RB / 0 RB Offset
							1 RB / 49 RB Offset
							50 RB / 0 RB Offset
A	0, 1	CONDCUDET ED EMISSION	19975 to 20375	20175	5MHz	QPSK	1 RB / 12 RB Offset
			20000 to 20350	20175	10MHz	QPSK	1 RB / 24 RB Offset
A	0, 1	RADIATED EMISSION	20000 to 20350	20175	10MHz	QPSK	1 RB / 24 RB Offset
							1 RB / 0 RB Offset
B	0	RADIATED EMISSION	20000 to 20350	20175	10MHz	QPSK	1 RB / 24 RB Offset

Note: This device was tested under all bandwidths, RB configurations and modulations. The worst case were found in QPSK modulation.

TEST CONDITION:

TEST ITEM	ENVIRONMENTAL CONDITIONS	INPUT POWER	TESTED BY
ERP/EIRP	26deg. C, 58%RH	3.8Vdc	Phoenix Chen
FREQUENCY STABILITY	26deg. C, 58%RH	3.8Vdc	Phoenix Chen
OCCUPIED BANDWIDTH	26deg. C, 58%RH	3.8Vdc	Phoenix Chen
BAND EDGE	26deg. C, 58%RH	3.8Vdc	Phoenix Chen
CONDCUDET ED EMISSION	26deg. C, 58%RH	3.8Vdc	Phoenix Chen
RADIATED EMISSION	25deg. C, 65%RH	120Vac, 60Hz	Kay Wu

3.5 GENERAL DESCRIPTION OF APPLIED STANDARDS

The EUT is a RF product. According to the specifications of the manufacturer, it must comply with the requirements of the following standards:

FCC 47 CFR Part 2

FCC 47 CFR Part 27

ANSI C63.4-2003

ANSI/TIA/EIA-603-C 2004

NOTE: All test items have been performed and recorded as per the above standards.

NOTE: The EUT is also considered as a kind of computer peripheral, because the connection to computer is necessary for typical use. It has been verified to comply with the requirements of FCC Part 15, Subpart B, Class B. The test report has been issued separately.

4 TEST TYPES AND RESULTS

4.1 OUTPUT POWER MEASUREMENT

4.1.1 LIMITS OF OUTPUT POWER MEASUREMENT

Fixed, mobile, and portable (hand-held) stations operating in the 1710–1755 MHz band are limited to 1 watt EIRP.

Portable stations (hand-held devices) operating in the 704-716 MHz band are limited to 3 watts ERP

4.1.2 TEST PROCEDURES

EIRP / ERP MEASUREMENT:

- a. The EUT was set up for the maximum power with LTE link data modulation. The power was measured with R&S Spectrum Analyzer. All measurements were done at 3 channels (low, middle and high operational frequency range). RBW and VBW is 10MHz for LTE.
- b. E.I.R.P power measurement. In the semi-anechoic chamber, EUT placed on the 0.8m height of Turn Table, rotated the table around 360 degrees to search the maximum radiation power and receiver antenna shall be rotated vertical and horizontal polarization and moved height from 1m to 4m to find the maximum polar radiated power. The “Read Value” is the spectrum reading the maximum power value.
- c. The substitution horn antenna is substituted for EUT at the same position and signals generator export the CW signal to the substitution antenna via a TX cable. Rotated the Turn Table and moved receiving antenna to find the maximum radiation power. Adjust output power level of S.G to get a Value of spectrum reading equal to “Read Value” of step a. Record the power level of S.G
- d. $EIRP = \text{Output power level of S.G} - \text{TX cable loss} + \text{Antenna gain of substitution horn}$
- e. $E.R.P = E.I.R.P - 2.15 \text{ dB}$

CONDUCTED POWER MEASUREMENT:

- a. The EUT was set up for the maximum power with LTE link data modulation and link up with simulator.
- b. Set the EUT to transmit under low, middle and high channel and record the power level shown on simulator.

4.1.3 TEST SETUP

EIRP / ERP MEASUREMENT:

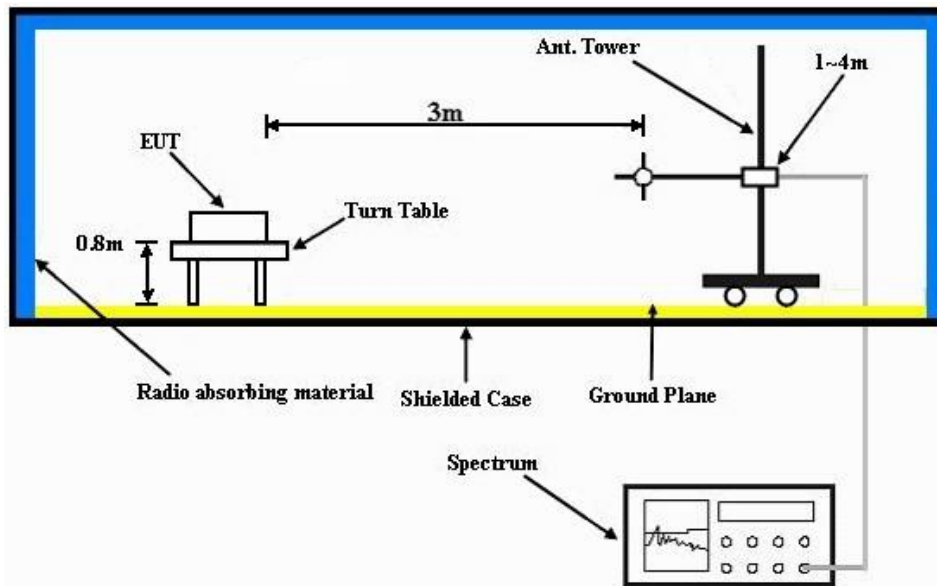

For the actual test configuration, please refer to the attached file (Test Setup Photo).

CONDUCTED POWER MEASUREMENT:

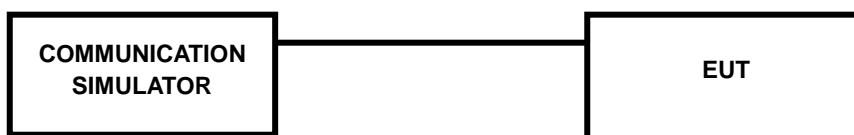

For the actual test configuration, please refer to the attached file (Test Setup Photo).

4.1.4 TEST RESULTS

AVERAGE CONDUCTED OUTPUT POWER (dBm)

LTE Band 17								
BW	Modulation	CH	Frequency	RB	RB Offset	MPR	Target	Measured
			(MHz)				Power	Power
5 MHz	QPSK	23755	706.5	1	0	0	23	22.64
		23790	710	1	0	0	23	22.59
		23825	713.5	1	0	0	23	22.41
		23755	706.5	1	12	0	23	22.71
		23790	710	1	12	0	23	22.66
		23825	713.5	1	12	0	23	22.48
		23755	706.5	1	24	0	23	22.63
		23790	710	1	24	0	23	22.58
		23825	713.5	1	24	0	23	22.4
		23755	706.5	12	0	1	23	21.53
		23790	710	12	0	1	23	21.48
		23825	713.5	12	0	1	23	21.3
		23755	706.5	12	6	1	23	21.51
		23790	710	12	6	1	23	21.46
		23825	713.5	12	6	1	23	21.28
	23755	706.5	12	13	1	23	21.39	
	23790	710	12	13	1	23	21.34	
	23825	713.5	12	13	1	23	21.16	
	23755	706.5	25	0	1	23	21.45	
	23790	710	25	0	1	23	21.4	
	23825	713.5	25	0	1	23	21.22	
	23755	706.5	1	0	1	23	21.65	
	23790	710	1	0	1	23	21.6	
	23825	713.5	1	0	1	23	21.42	
	23755	706.5	1	12	1	23	21.56	
	23790	710	1	12	1	23	21.51	
	23825	713.5	1	12	1	23	21.33	
	23755	706.5	1	24	1	23	21.67	
	23790	710	1	24	1	23	21.62	
	23825	713.5	1	24	1	23	21.44	
23755	706.5	12	0	2	23	20.52		
23790	710	12	0	2	23	20.47		
23825	713.5	12	0	2	23	20.29		
23755	706.5	12	6	2	23	20.57		
23790	710	12	6	2	23	20.52		
23825	713.5	12	6	2	23	20.34		
23755	706.5	12	13	2	23	20.51		
23790	710	12	13	2	23	20.46		
23825	713.5	12	13	2	23	20.28		
23755	706.5	25	0	2	23	20.41		
23790	710	25	0	2	23	20.36		
23825	713.5	25	0	2	23	20.18		



A D T

LTE Band 17								
BW	Modulation	CH	Frequency	RB	RB Offset	MPR	Target	Measured
			(MHz)				Power	Power
10MHz	QPSK	23780	709	1	0	0	23	22.84
		23790	710	1	0	0	23	22.65
		23800	711	1	0	0	23	22.59
		23780	709	1	24	0	23	22.84
		23790	710	1	24	0	23	22.72
		23800	711	1	24	0	23	22.75
		23780	709	1	49	0	23	22.6
		23790	710	1	49	0	23	22.58
		23800	711	1	49	0	23	22.58
		23780	709	25	0	1	23	21.66
		23790	710	25	0	1	23	21.38
		23800	711	25	0	1	23	21.44
		23780	709	25	12	1	23	21.61
		23790	710	25	12	1	23	21.45
		23800	711	25	12	1	23	21.43
		23780	709	25	25	1	23	21.59
		23790	710	25	25	1	23	21.48
		23800	711	25	25	1	23	21.38
	23780	709	50	0	1	23	21.52	
	23790	710	50	0	1	23	21.39	
	23800	711	50	0	1	23	21.36	
	23780	709	1	0	1	23	21.72	
	23790	710	1	0	1	23	21.66	
	23800	711	1	0	1	23	21.61	
	23780	709	1	24	1	23	21.82	
	23790	710	1	24	1	23	21.6	
	23800	711	1	24	1	23	21.81	
	23780	709	1	49	1	23	21.8	
	23790	710	1	49	1	23	21.69	
	23800	711	1	49	1	23	21.55	
	23780	709	25	0	2	23	20.55	
	23790	710	25	0	2	23	20.44	
	23800	711	25	0	2	23	20.42	
	23780	709	25	12	2	23	20.63	
	23790	710	25	12	2	23	20.44	
	23800	711	25	12	2	23	20.37	
23780	709	25	25	2	23	20.67		
23790	710	25	25	2	23	20.52		
23800	711	25	25	2	23	20.36		
23780	709	50	0	2	23	20.58		
23790	710	50	0	2	23	20.38		
23800	711	50	0	2	23	20.39		
16QAM								



A D T

LTE Band 4								
BW	Modulation	CH	Frequency	RB	RB Offset	MPR	Target	Measured
			(MHz)				Power	Power
5 MHz	QPSK	19975	1712.5	1	0	0	23	22.55
		20175	1732.5	1	0	0	23	22.44
		20375	1752.5	1	0	0	23	22.71
		19975	1712.5	1	12	0	23	22.71
		20175	1732.5	1	12	0	23	22.5
		20375	1752.5	1	12	0	23	22.77
		19975	1712.5	1	24	0	23	22.47
		20175	1732.5	1	24	0	23	22.26
		20375	1752.5	1	24	0	23	22.53
		19975	1712.5	12	0	1	23	21.55
		20175	1732.5	12	0	1	23	21.34
		20375	1752.5	12	0	1	23	21.61
		19975	1712.5	12	6	1	23	21.5
		20175	1732.5	12	6	1	23	21.29
		20375	1752.5	12	6	1	23	21.56
		19975	1712.5	12	13	1	23	21.59
		20175	1732.5	12	13	1	23	21.38
		20375	1752.5	12	13	1	23	21.65
	19975	1712.5	25	0	1	23	21.37	
	20175	1732.5	25	0	1	23	21.16	
	20375	1752.5	25	0	1	23	21.43	
	19975	1712.5	1	0	1	23	21.64	
	20175	1732.5	1	0	1	23	21.43	
	20375	1752.5	1	0	1	23	21.7	
	19975	1712.5	1	12	1	23	21.68	
	20175	1732.5	1	12	1	23	21.47	
	20375	1752.5	1	12	1	23	21.74	
	19975	1712.5	1	24	1	23	21.53	
	20175	1732.5	1	24	1	23	21.32	
	20375	1752.5	1	24	1	23	21.59	
	19975	1712.5	12	0	2	23	20.64	
	20175	1732.5	12	0	2	23	20.43	
	20375	1752.5	12	0	2	23	20.7	
	19975	1712.5	12	6	2	23	20.63	
	20175	1732.5	12	6	2	23	20.42	
	20375	1752.5	12	6	2	23	20.69	
19975	1712.5	12	13	2	23	20.67		
20175	1732.5	12	13	2	23	20.46		
20375	1752.5	12	13	2	23	20.73		
19975	1712.5	25	0	2	23	20.41		
20175	1732.5	25	0	2	23	20.2		
20375	1752.5	25	0	2	23	20.47		



A D T

LTE Band 4								
BW	Modulation	CH	Frequency	RB	RB Offset	MPR	Target	Measured
			(MHz)				Power	Power
10MHz	QPSK	20000	1715	1	0	0	23	22.61
		20175	1732.5	1	0	0	23	22.71
		20350	1750	1	0	0	23	22.93
		20000	1715	1	24	0	23	23
		20175	1732.5	1	24	0	23	22.55
		20350	1750	1	24	0	23	22.71
		20000	1715	1	49	0	23	22.49
		20175	1732.5	1	49	0	23	22.32
		20350	1750	1	49	0	23	22.53
		20000	1715	25	0	1	23	21.57
		20175	1732.5	25	0	1	23	21.3
		20350	1750	25	0	1	23	21.55
		20000	1715	25	12	1	23	21.59
		20175	1732.5	25	12	1	23	21.26
		20350	1750	25	12	1	23	21.42
		20000	1715	25	25	1	23	21.53
		20175	1732.5	25	25	1	23	21.32
		20350	1750	25	25	1	23	21.43
	20000	1715	50	0	1	23	21.3	
	20175	1732.5	50	0	1	23	21.2	
	20350	1750	50	0	1	23	21.33	
	20000	1715	1	0	1	23	21.57	
	20175	1732.5	1	0	1	23	21.54	
	20350	1750	1	0	1	23	21.75	
	20000	1715	1	24	1	23	21.93	
	20175	1732.5	1	24	1	23	21.34	
	20350	1750	1	24	1	23	21.69	
	20000	1715	1	49	1	23	21.55	
	20175	1732.5	1	49	1	23	21.16	
	20350	1750	1	49	1	23	21.43	
	20000	1715	25	0	2	23	20.4	
	20175	1732.5	25	0	2	23	20.3	
	20350	1750	25	0	2	23	20.63	
	20000	1715	25	12	2	23	20.53	
	20175	1732.5	25	12	2	23	20.39	
	20350	1750	25	12	2	23	20.47	
20000	1715	25	25	2	23	20.51		
20175	1732.5	25	25	2	23	20.37		
20350	1750	25	25	2	23	20.48		
20000	1715	50	0	2	23	20.36		
20175	1732.5	50	0	2	23	20.2		
20350	1750	50	0	2	23	20.42		

ANT.0
AVERAGE ERP (dBm)
LTE BAND 17
Main Sample (A)
CHANNEL BANDWIDTH: 10MHz QPSK (1 RB / 24 RB Offset)

Plane	Channel	Frequency (MHz)	LVL (dBm)	Correction Factor(dB)	ERP(dBm)	ERP(mW)	Polarization (H/V)
X	23780	709.0	-12.89	30.17	15.13	32.58	H
	23790	710.0	-12.70	30.17	15.32	34.04	
	23800	711.0	-12.51	30.18	15.52	35.65	
	23780	709.0	-19.33	31.96	10.48	11.17	V
	23790	710.0	-19.15	31.98	10.68	11.69	
	23800	711.0	-19.22	32.03	10.66	11.64	

2nd Sample (B)
CHANNEL BANDWIDTH: 10MHz QPSK (1 RB / 24 RB Offset)

Plane	Channel	Frequency (MHz)	LVL (dBm)	Correction Factor(dB)	ERP(dBm)	ERP(mW)	Polarization (H/V)
X	23780	709.0	-12.69	30.17	15.33	34.12	H
	23790	710.0	-12.79	30.17	15.23	33.34	
	23800	711.0	-12.74	30.18	15.29	33.81	
	23780	709.0	-19.75	31.96	10.06	10.14	V
	23790	710.0	-19.51	31.98	10.32	10.76	
	23800	711.0	-19.30	32.03	10.58	11.43	

AVERAGE EIRP (dBm)

LTE BAND 4

Main Sample (A)

CHANNEL BANDWIDTH: 10MHz QPSK (1 RB / 24 RB Offset)

Plane	Channel	Frequency (MHz)	LVL (dBm)	Correction Factor(dB)	EIRP(dBm)	EIRP(mW)	Polarization (H/V)
Y	20000	1715.0	-22.13	37.99	15.86	38.55	H
	20175	1732.5	-22.86	37.99	15.13	32.58	
	20350	1750.0	-22.08	38.36	16.28	42.46	
	20000	1715.0	-17.86	37.91	20.05	101.16	V
	20175	1732.5	-17.86	38.00	20.14	103.28	
	20350	1750.0	-17.80	38.28	20.48	111.69	

2nd Sample (B)

CHANNEL BANDWIDTH: 10MHz QPSK (1 RB / 24 RB Offset)

Plane	Channel	Frequency (MHz)	LVL (dBm)	Correction Factor(dB)	EIRP(dBm)	EIRP(mW)	Polarization (H/V)
Y	20000	1715.0	-17.94	37.99	20.05	101.16	H
	20175	1732.5	-17.95	37.99	20.04	100.93	
	20350	1750.0	-18.03	38.36	20.33	107.89	
	20000	1715.0	-25.89	37.91	12.02	15.92	V
	20175	1732.5	-25.81	38.00	12.19	16.56	
	20350	1750.0	-26.19	38.28	12.09	16.18	



A D T

ANT.1

AVERAGE ERP (dBm)

LTE BAND 17

CHANNEL BANDWIDTH: 10MHz QPSK (1 RB / 49 RB Offset)

Plane	Channel	Frequency (MHz)	LVL (dBm)	Correction Factor(dB)	ERP(dBm)	ERP(mW)	Polarization (H/V)
X	23780	709.0	-13.00	30.17	15.02	31.77	H
	23790	710.0	-12.92	30.17	15.10	32.36	
	23800	711.0	-12.92	30.18	15.11	32.43	
	23780	709.0	-25.88	31.96	3.93	2.47	V
	23790	710.0	-25.67	31.98	4.16	2.61	
	23800	711.0	-25.65	32.03	4.23	2.65	

AVERAGE EIRP (dBm)

LTE BAND 4

CHANNEL BANDWIDTH: 10MHz QPSK (1 RB / 0 RB Offset)

Plane	Channel	Frequency (MHz)	LVL (dBm)	Correction Factor(dB)	EIRP(dBm)	EIRP(mW)	Polarization (H/V)
Y	20000	1715.0	-30.78	37.99	7.21	5.26	H
	20175	1732.5	-30.90	37.99	7.09	5.12	
	20350	1750.0	-30.63	38.36	7.73	5.93	
	20000	1715.0	-26.03	37.91	11.88	15.42	V
	20175	1732.5	-26.12	38.00	11.88	15.42	
	20350	1750.0	-26.65	38.28	11.63	14.55	

4.2 FREQUENCY STABILITY MEASUREMENT

4.2.1 LIMITS OF FREQUENCY STABILITY MEASUREMENT

The frequency stability shall be sufficient to ensure that the fundamental emissions stay within the authorized bands of operation.

4.2.2 TEST PROCEDURE

- a. Device is placed at the oven room. The oven room could control the temperatures and humidity. Power warm up is at least 15 min and power applied should perform before recording frequency error.
- b. EUT is connected the external power supply to control the DC input power. The test voltage range is from minimum to maximum working voltage. Each step shall be record the frequency error rate.
- c. The temperature range step is 10 degrees in this test items. All temperature levels shall be hold the $\pm 0.5^{\circ}\text{C}$ during the measurement testing. The each temperature step shall be at least 0.5 hours, consider the EUT could be test under the stability condition.

NOTE: The frequency error was recorded frequency error from the communication simulator.

4.2.3 TEST SETUP

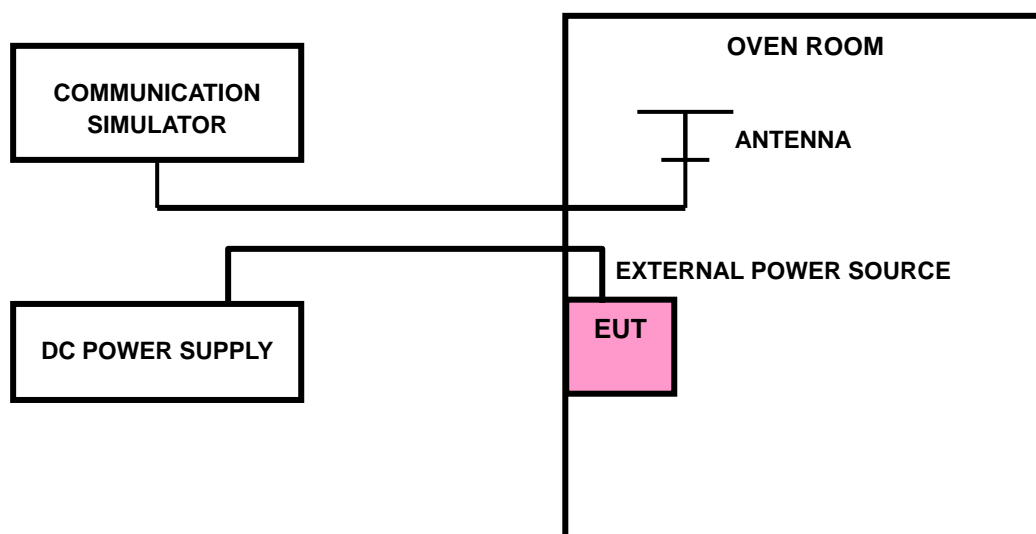

4.2.4 TEST RESULTS

ANT.0

VOLTAGE (Volts)	FREQUENCY ERROR (ppm)				LIMIT (ppm)
	LTE BAND 4		LTE BAND 17		
	5MHz	10MHz	5MHz	10MHz	
3.8	0.0032	-0.0039	-0.007	-0.007	2.5
3.6	0.0047	-0.0045	0.005	-0.004	2.5
4.35	0.0046	-0.0052	-0.004	-0.005	2.5

NOTE: The applicant defined the normal working voltage of the battery is from 3.6Vdc to 4.35Vdc.

TEMP. (°C)	FREQUENCY ERROR (ppm)				LIMIT (ppm)
	LTE BAND 4		LTE BAND 17		
	5MHz	10MHz	5MHz	10MHz	
-30	0.0069	0.0059	-0.011	-0.01	2.5
-20	0.0035	0.0023	0.004	-0.01	2.5
-10	0.0052	0.0034	-0.004	-0.01	2.5
0	0.0031	0.0036	-0.005	-0.01	2.5
10	0.0038	-0.0044	-0.005	-0.01	2.5
20	0.0039	-0.0053	-0.007	-0.01	2.5
30	0.0047	0.0034	-0.010	-0.01	2.5
40	0.0055	0.0042	-0.010	-0.01	2.5
50	0.0048	0.0042	-0.005	-0.01	2.5
55	0.0032	0.0060	-0.007	-0.01	2.5

ANT.1

VOLTAGE (Volts)	FREQUENCY ERROR (ppm)				LIMIT (ppm)
	LTE BAND 4		LTE BAND 17		
	5MHz	10MHz	5MHz	10MHz	
3.8	0.0032	0.0013	-0.010	0.001	2.5
3.6	-0.0018	-0.0012	0.005	0.005	2.5
4.35	-0.0029	-0.0021	0.006	0.010	2.5

NOTE: The applicant defined the normal working voltage of the battery is from 3.6Vdc to 4.35Vdc.

TEMP. (°C)	FREQUENCY ERROR (ppm)				LIMIT (ppm)
	LTE BAND 4		LTE BAND 17		
	5MHz	10MHz	5MHz	10MHz	
-30	-0.0025	0.0014	-0.010	0.001	2.5
-20	0.0021	-0.0013	0.003	-0.010	2.5
-10	0.0006	-0.0009	-0.010	-0.002	2.5
0	0.0034	0.0001	-0.010	0.002	2.5
10	0.0018	-0.0008	0.005	-0.010	2.5
20	0.0041	0.0018	-0.010	-0.010	2.5
30	0.0035	-0.0021	0.004	0.002	2.5
40	0.0030	0.0024	0.002	-0.010	2.5
50	0.0012	-0.0021	0.005	0.003	2.5
55	0.0018	0.0036	0.004	0.002	2.5

4.3 OCCUPIED BANDWIDTH MEASUREMENT

4.3.1 LIMITS OF OCCUPIED BANDWIDTH MEASUREMENT

The width of a frequency band such that, below the lower and above the upper frequency limits, the mean powers emitted are each equal to a specified percentage 0.5 %of the total mean power of a given emission.

4.3.2 TEST SETUP

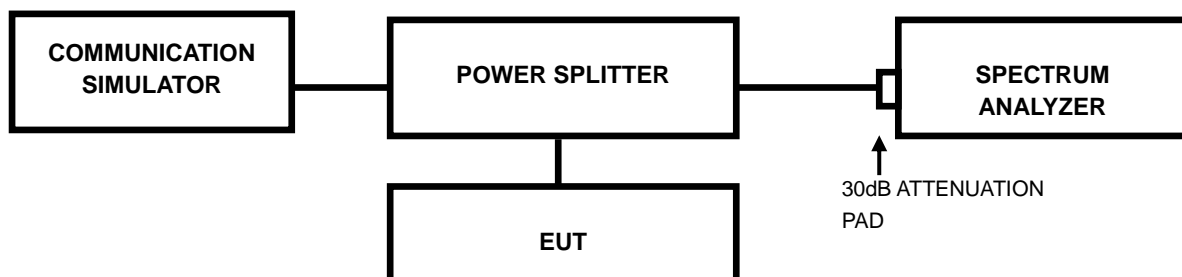

4.3.3 TEST PROCEDURES

- The conducted occupied bandwidth used the power splitter via EUT RF power connector between simulation base station and spectrum analyzer.
- Use OBW measurement function of Spectrum analyzer to measure 99 % occupied bandwidth.

4.3.4 TEST RESULTS

ANT.0

LTE BAND 17							
CHANNEL BANDWIDTH: 5MHz				CHANNEL BANDWIDTH: 10MHz			
CHANNEL	FREQUENCY (MHz)	99% OCCUPIED BANDWIDTH (MHz)		CHANNEL	FREQUENCY (MHz)	99% OCCUPIED BANDWIDTH (MHz)	
		QPSK	16QAM			QPSK	16QAM
23755	706.5	4.49	4.49	23780	709.0	8.93	8.92
23790	710.0	4.50	4.50	23790	710.0	8.93	8.93
23825	713.5	4.49	4.48	23800	711.0	8.94	8.93

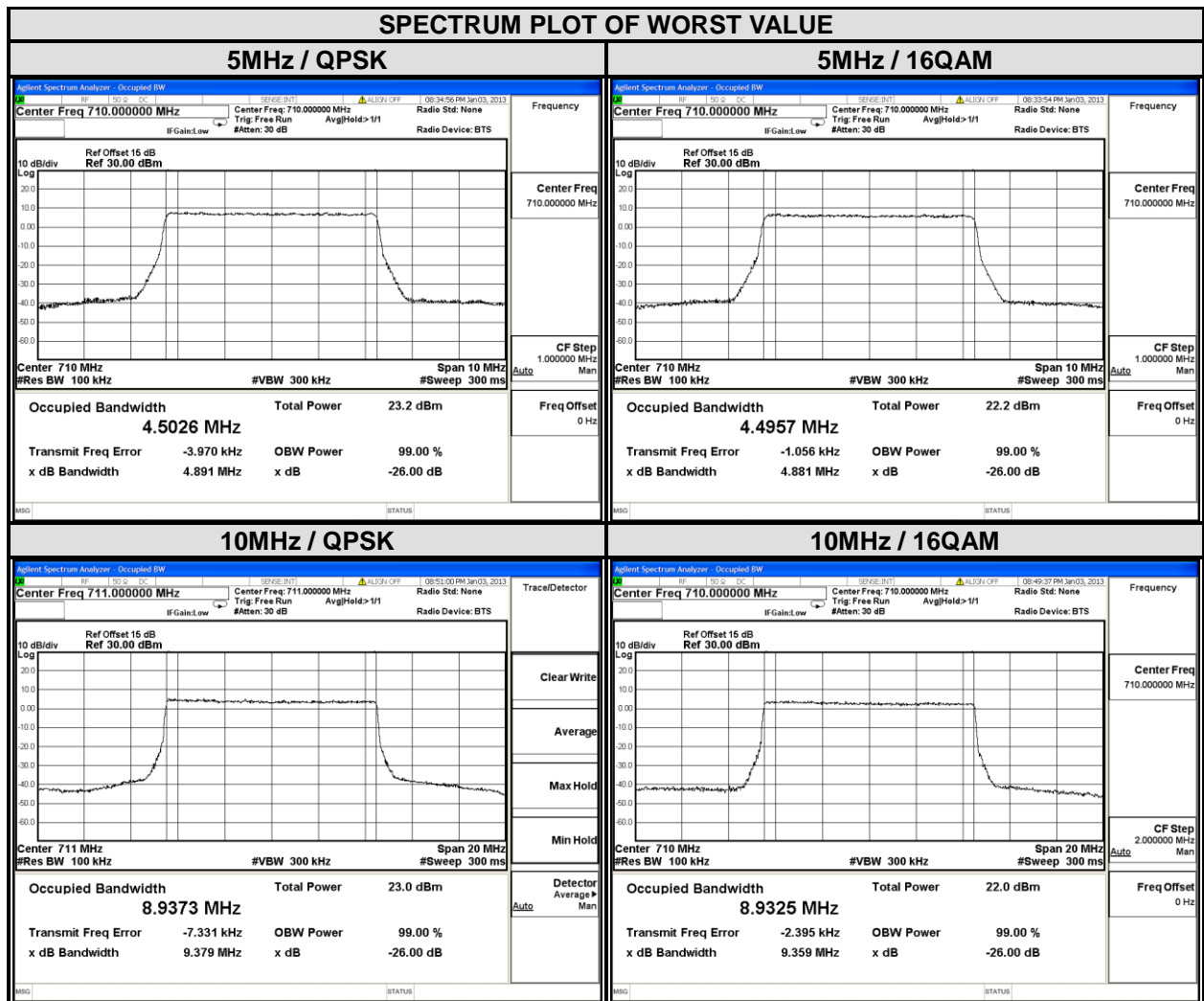



A D T

LTE BAND 4							
CHANNEL BANDWIDTH: 5MHz				CHANNEL BANDWIDTH: 10MHz			
CHANNEL	FREQUENCY (MHz)	99% OCCUPIED BANDWIDTH (MHz)		CHANNEL	FREQUENCY (MHz)	99% OCCUPIED BANDWIDTH (MHz)	
		QPSK	16QAM			QPSK	16QAM
19975	1712.5	4.50	4.49	20000	1715.0	8.91	8.91
20175	1732.5	4.49	4.48	20175	1732.5	8.92	8.91
20375	1752.5	4.49	4.49	20350	1750.0	8.93	8.91

SPECTRUM PLOT OF WORST VALUE

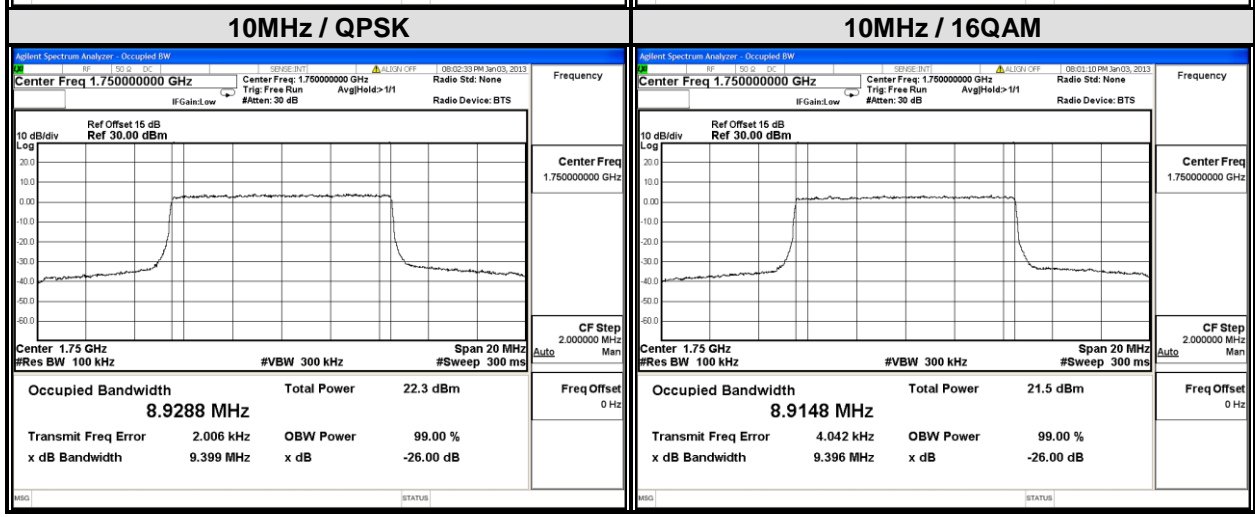
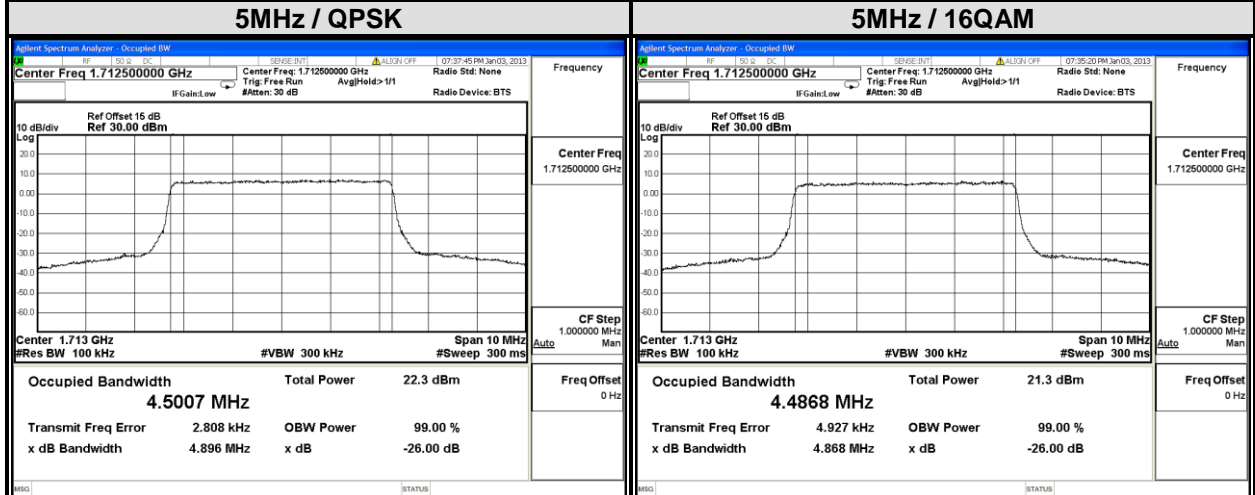



A D T

ANT.1

LTE BAND 17							
CHANNEL BANDWIDTH: 5MHz				CHANNEL BANDWIDTH: 10MHz			
CHANNEL	FREQUENCY (MHz)	99% OCCUPIED BANDWIDTH (MHz)		CHANNEL	FREQUENCY (MHz)	99% OCCUPIED BANDWIDTH (MHz)	
		QPSK	16QAM			QPSK	16QAM
23755	706.5	4.48	4.48	23780	709.0	8.93	8.92
23790	710.0	4.49	4.49	23790	710.0	8.93	8.93
23825	713.5	4.48	4.47	23800	711.0	8.93	8.93

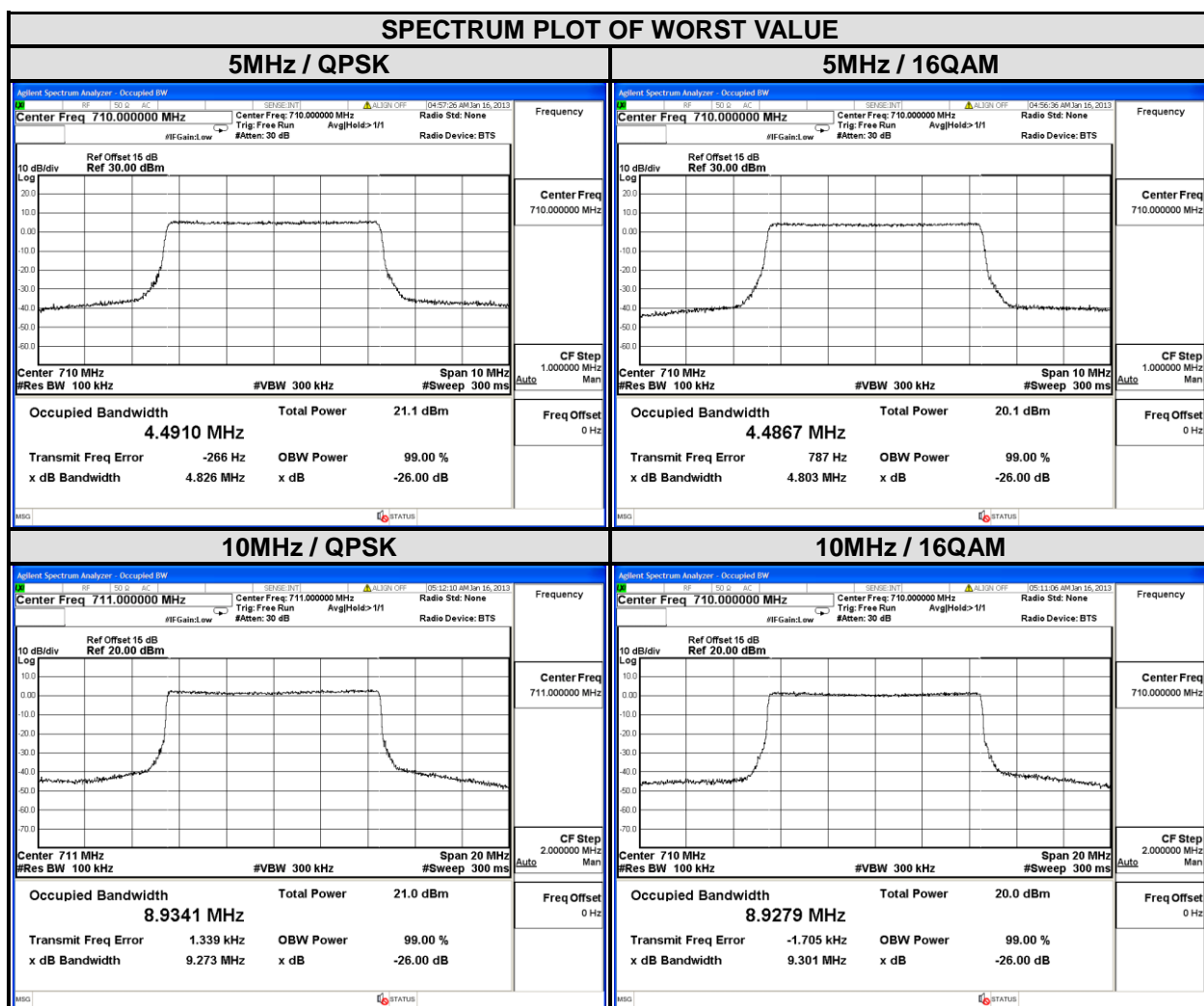



A D T

LTE BAND 4							
CHANNEL BANDWIDTH: 5MHz				CHANNEL BANDWIDTH: 10MHz			
CHANNEL	FREQUENCY (MHz)	99% OCCUPIED BANDWIDTH (MHz)		CHANNEL	FREQUENCY (MHz)	99% OCCUPIED BANDWIDTH (MHz)	
		QPSK	16QAM			QPSK	16QAM
19975	1712.5	4.49	4.48	20000	1715.0	8.91	8.90
20175	1732.5	4.48	4.48	20175	1732.5	8.91	8.90
20375	1752.5	4.48	4.48	20350	1750.0	8.91	8.91

SPECTRUM PLOT OF WORST VALUE

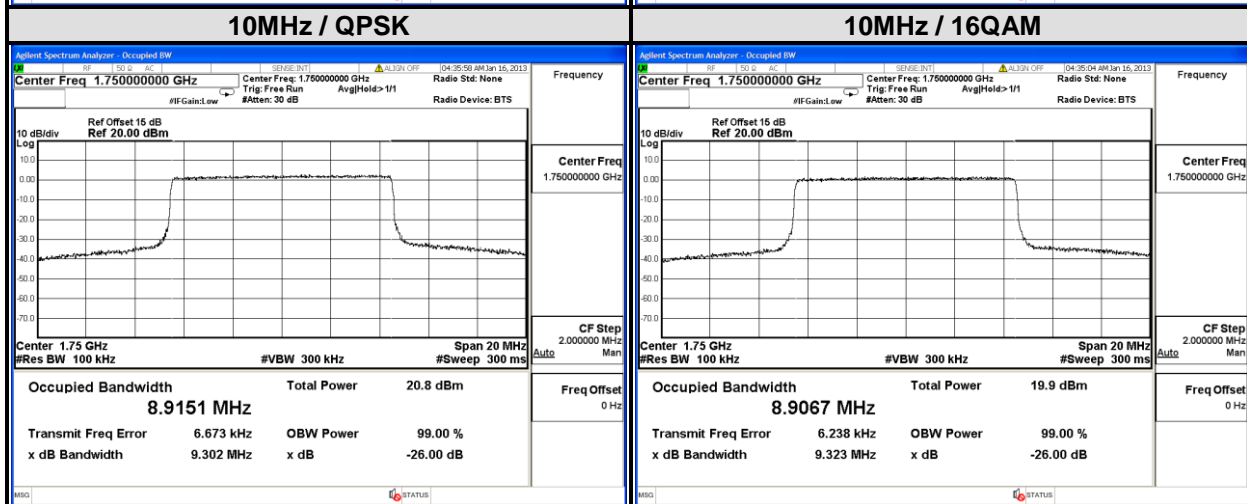
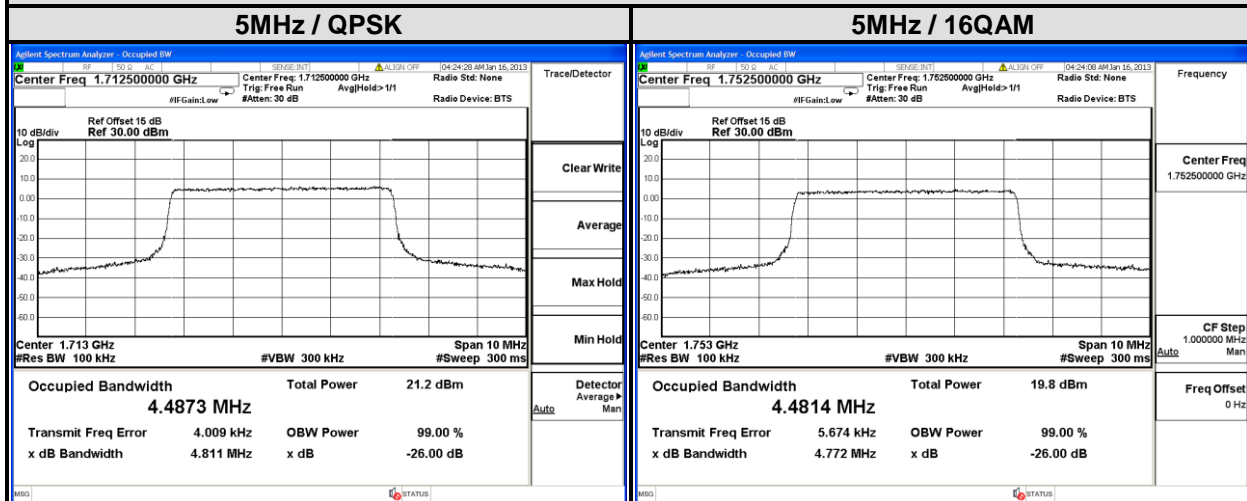

4.4 PEAK TO AVERAGE RATIO

4.4.1 LIMITS OF PEAK TO AVERAGE RATIO MEASUREMENT

In measuring transmissions in this band using an average power technique, the peak to-average ratio (PAR) of the transmission may not exceed 13 dB

4.4.2 TEST SETUP

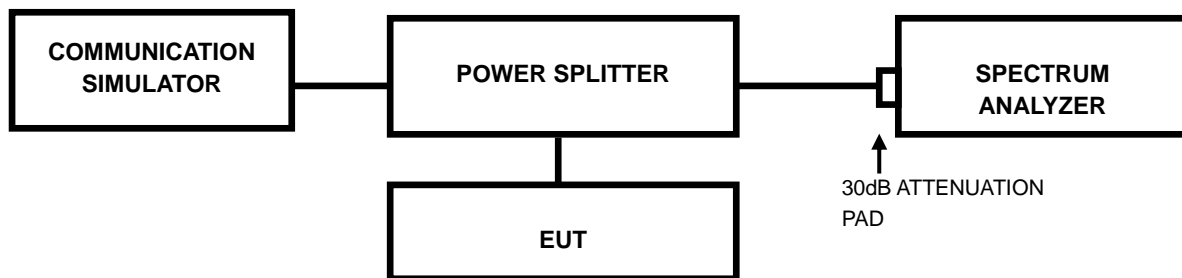

4.4.3 TEST PROCEDURES

1. Set resolution/measurement bandwidth \geq signal's occupied bandwidth;
2. Set the number of counts to a value that stabilizes the measured CCDF curve;
3. Record the maximum PAPR level associated with a probability of 0.1%.

4.4.4 TEST RESULTS

ANT.0

LTE BAND 17							
CHANNEL BANDWIDTH: 5MHz				CHANNEL BANDWIDTH: 10MHz			
CHANNEL	FREQUENCY (MHz)	PEAK TO AVERAGE RATIO (dB)		CHANNEL	FREQUENCY (MHz)	PEAK TO AVERAGE RATIO (dB)	
		QPSK	16QAM			QPSK	16QAM
23755	706.5	4.90	6.25	23780	709.0	5.55	5.87
23790	710.0	5.42	6.31	23790	710.0	5.51	6.23
23825	713.5	5.73	6.44	23800	711.0	5.33	5.68

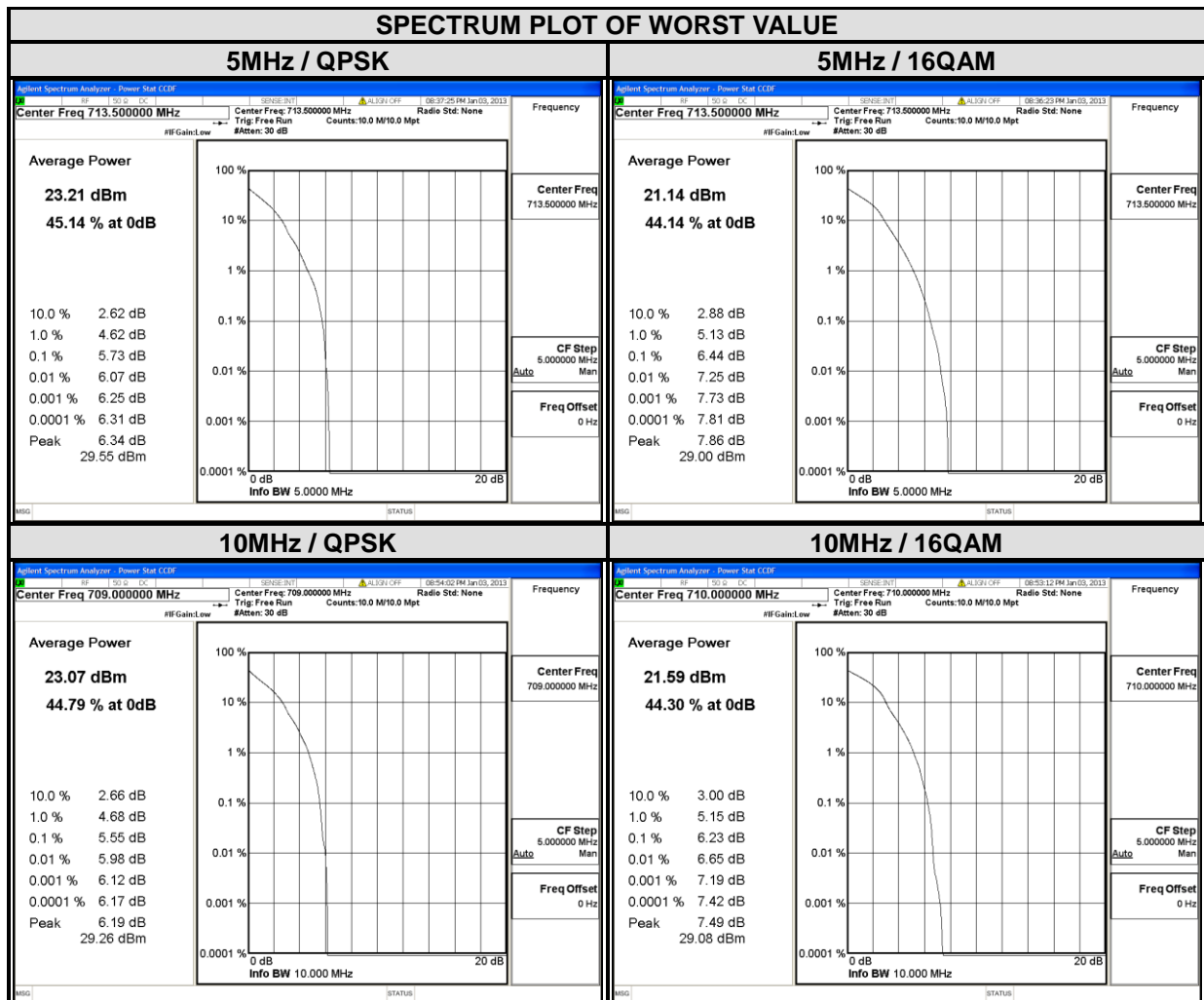



A D T

LTE BAND 4							
CHANNEL BANDWIDTH: 5MHz				CHANNEL BANDWIDTH: 10MHz			
CHANNEL	FREQUENCY (MHz)	PEAK TO AVERAGE RATIO (dB)		CHANNEL	FREQUENCY (MHz)	PEAK TO AVERAGE RATIO (dB)	
		QPSK	16QAM			QPSK	16QAM
19975	1712.5	5.69	6.53	20000	1715.0	5.69	6.78
20175	1732.5	4.43	5.54	20175	1732.5	4.20	5.21
20375	1752.5	5.50	6.26	20350	1750.0	5.65	6.53

SPECTRUM PLOT OF WORST VALUE

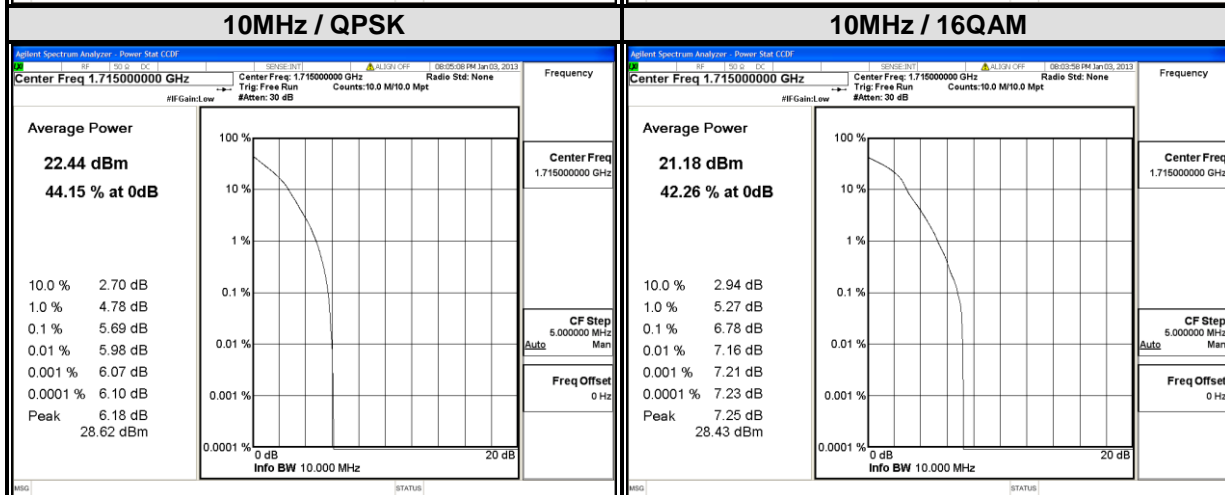
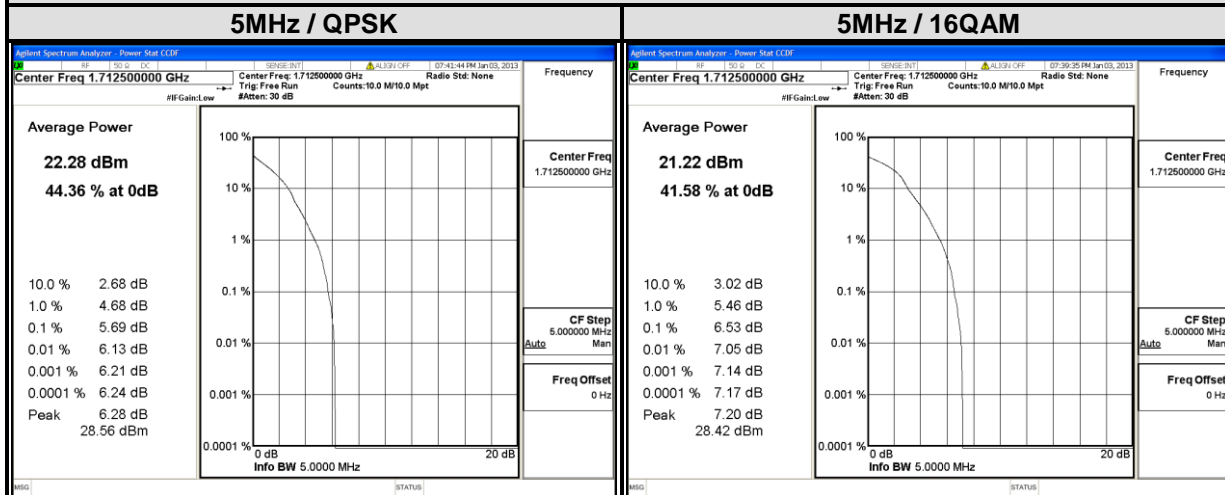



A D T

ANT.1

LTE BAND 17							
CHANNEL BANDWIDTH: 5MHz				CHANNEL BANDWIDTH: 10MHz			
CHANNEL	FREQUENCY (MHz)	PEAK TO AVERAGE RATIO (dB)		CHANNEL	FREQUENCY (MHz)	PEAK TO AVERAGE RATIO (dB)	
		QPSK	16QAM			QPSK	16QAM
23755	706.5	4.57	5.34	23780	709.0	5.20	5.79
23790	710.0	5.90	6.80	23790	710.0	5.40	6.26
23825	713.5	5.83	6.91	23800	711.0	5.71	6.72

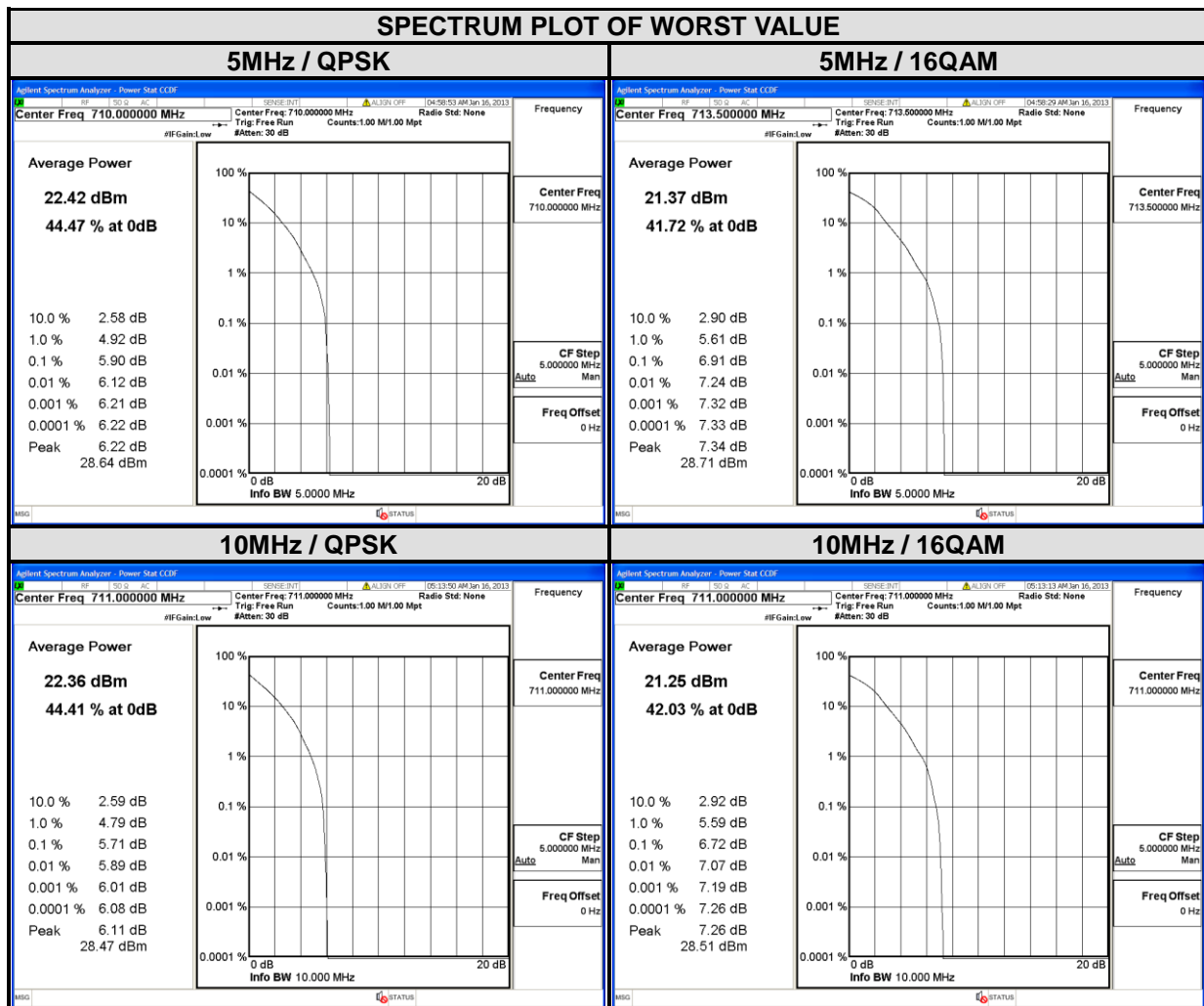



A D T

LTE BAND 4							
CHANNEL BANDWIDTH: 5MHz				CHANNEL BANDWIDTH: 10MHz			
CHANNEL	FREQUENCY (MHz)	PEAK TO AVERAGE RATIO (dB)		CHANNEL	FREQUENCY (MHz)	PEAK TO AVERAGE RATIO (dB)	
		QPSK	16QAM			QPSK	16QAM
19975	1712.5	5.63	6.69	20000	1715.0	5.90	6.74
20175	1732.5	3.87	5.02	20175	1732.5	3.85	4.93
20375	1752.5	5.48	6.68	20350	1750.0	5.64	6.71

SPECTRUM PLOT OF WORST VALUE

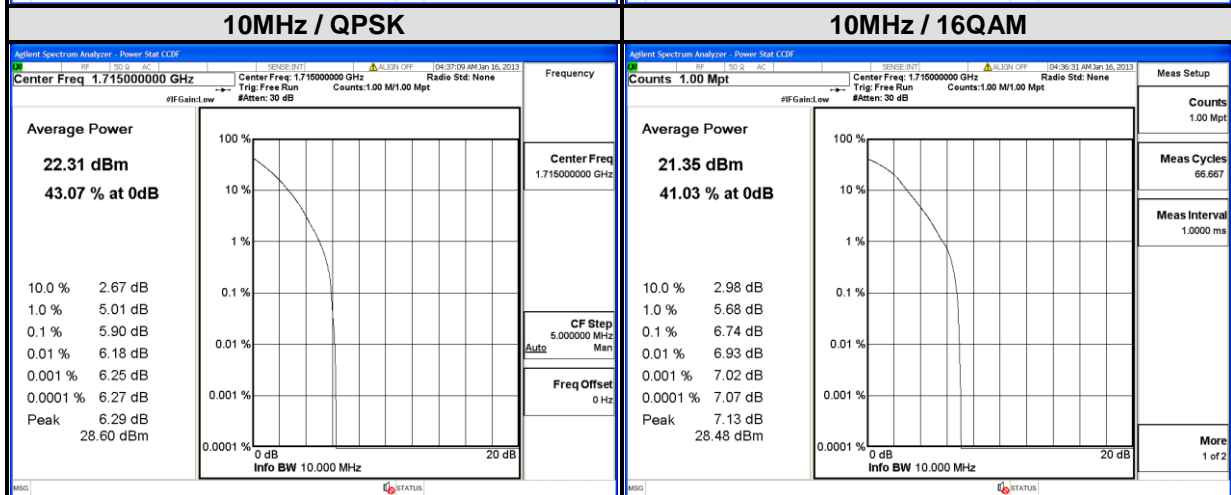
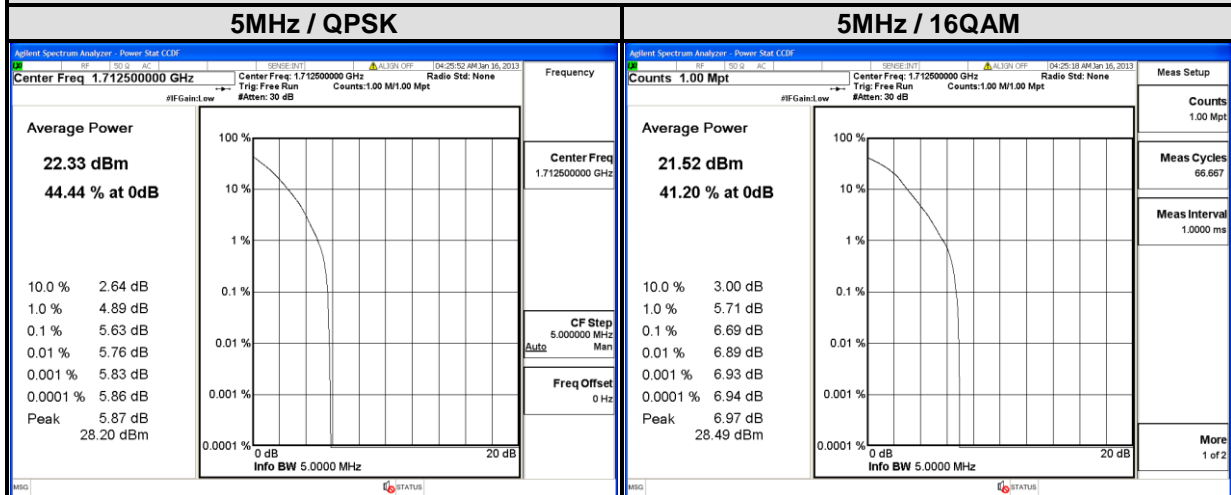

4.5 BAND EDGE MEASUREMENT

4.5.1 LIMITS OF BAND EDGE MEASUREMENT

For operations in the 704-716 MHz band, the power of any emission outside a licensee's frequency band(s) of operation shall be attenuated below the transmitter power (P) within the licensed band(s) of operation, measured in watts, by at least $43 + 10 \log(P)$ dB. Compliance with this provision is based on the use of measurement instrumentation employing a resolution bandwidth of 100 kilohertz or greater. However, in the 100 kilohertz bands immediately outside and adjacent to a licensee's frequency block, a resolution bandwidth of at least 30 kHz may be employed.

For operations in the 1710 – 1755 MHz MHz bands, the power of any emission outside a licensee's frequency block shall be attenuated below the transmitter power (P) by at least $43 + 10 \log_{10}(P)$ dB.

4.5.2 TEST SETUP

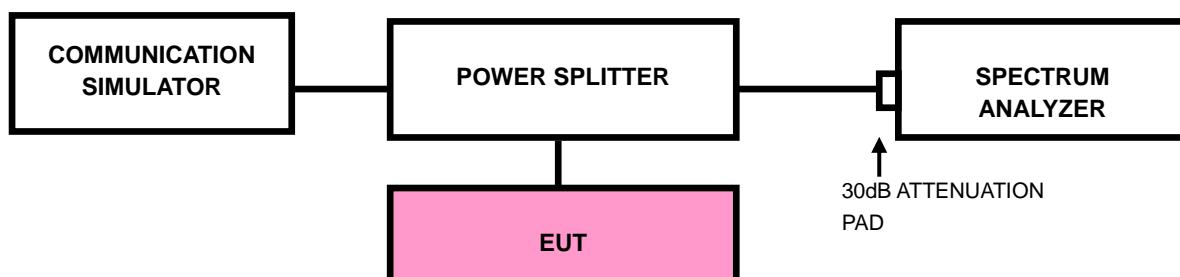

4.5.3 TEST PROCEDURES

- a. The EUT was set up for the maximum peak power with LTE link data modulation. The power was measured with R&S Spectrum Analyzer. All measurements were done at 2 channels (low and high operational frequency range.).
- b. The band edge measurement used the power splitter via EUT RF power connector between simulation base station and spectrum analyzer.
- c. The center frequency of spectrum is the band edge frequency and span is 2 MHz. RB of the spectrum is 100kHz and VB of the spectrum is 300kHz.
- d. Record the max trace plot into the test report.



A D T

4.5.4 TEST RESULTS

ANT.0

LTE BAND 17

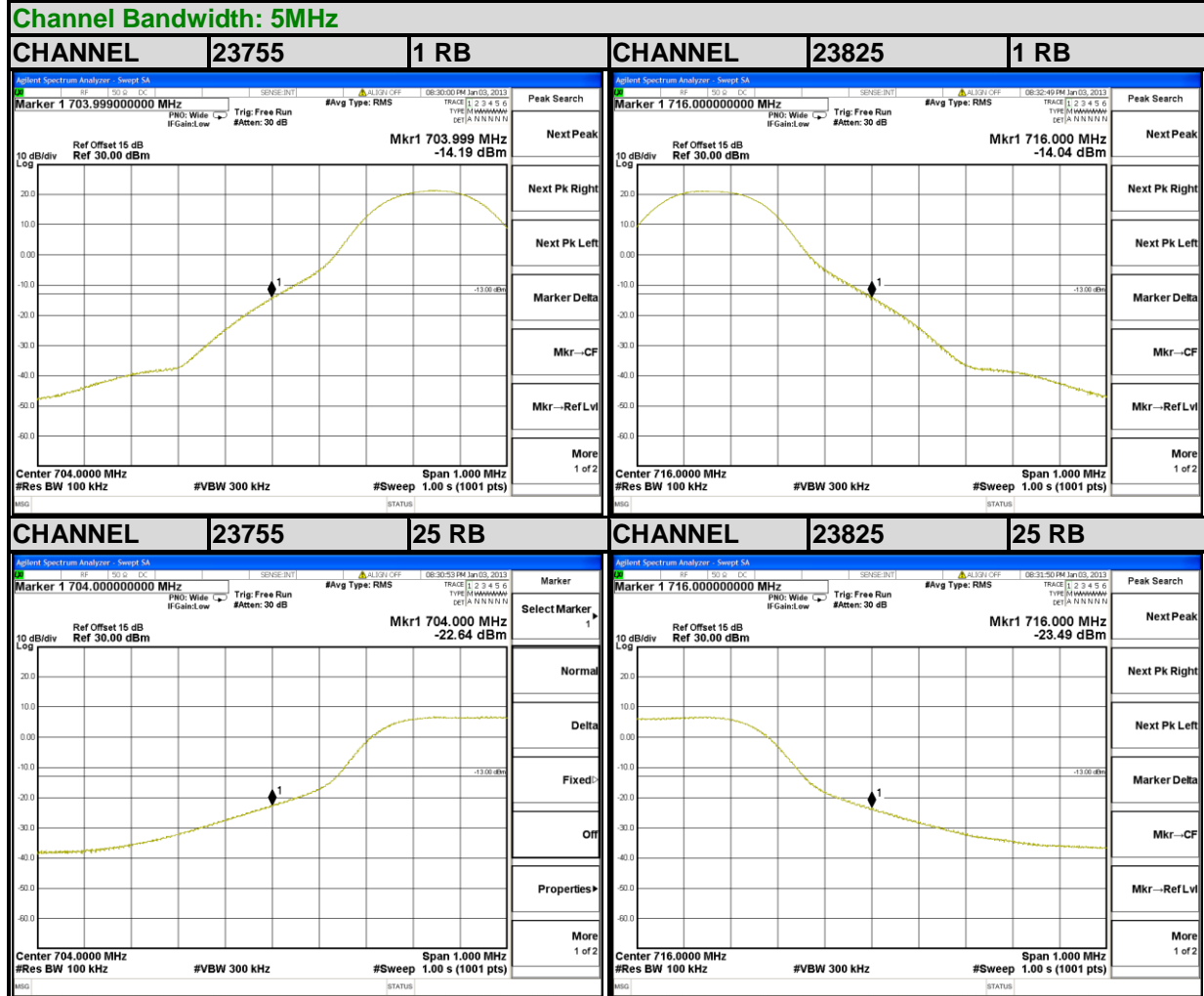



A D T

Channel Bandwidth: 10MHz

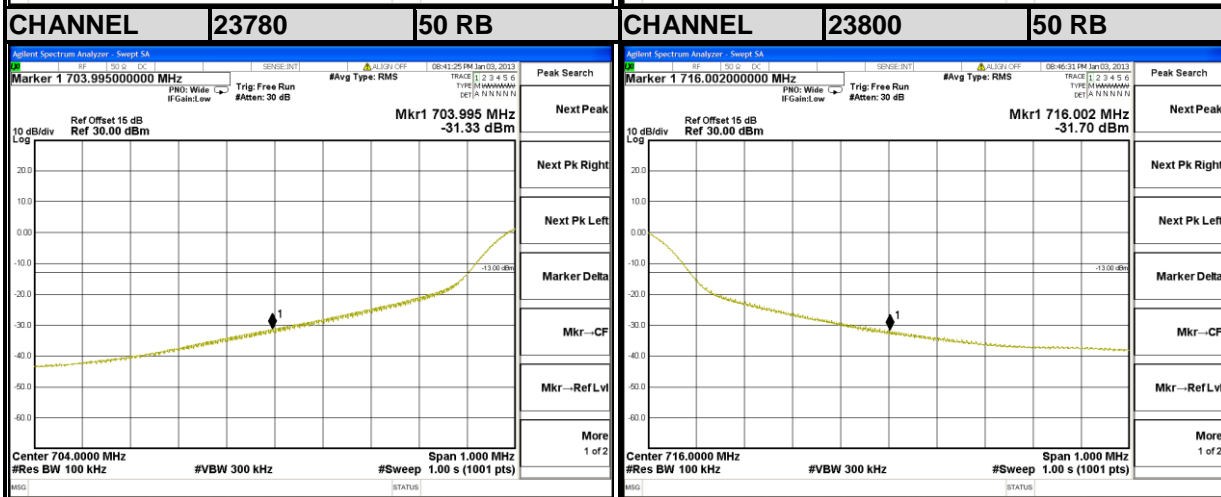
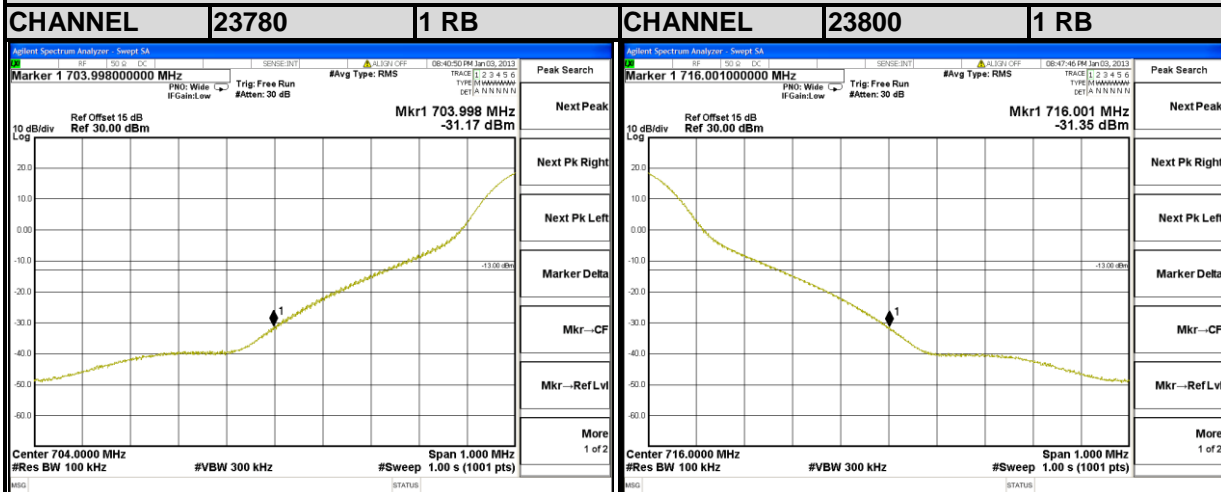



A D T

LTE BAND 4

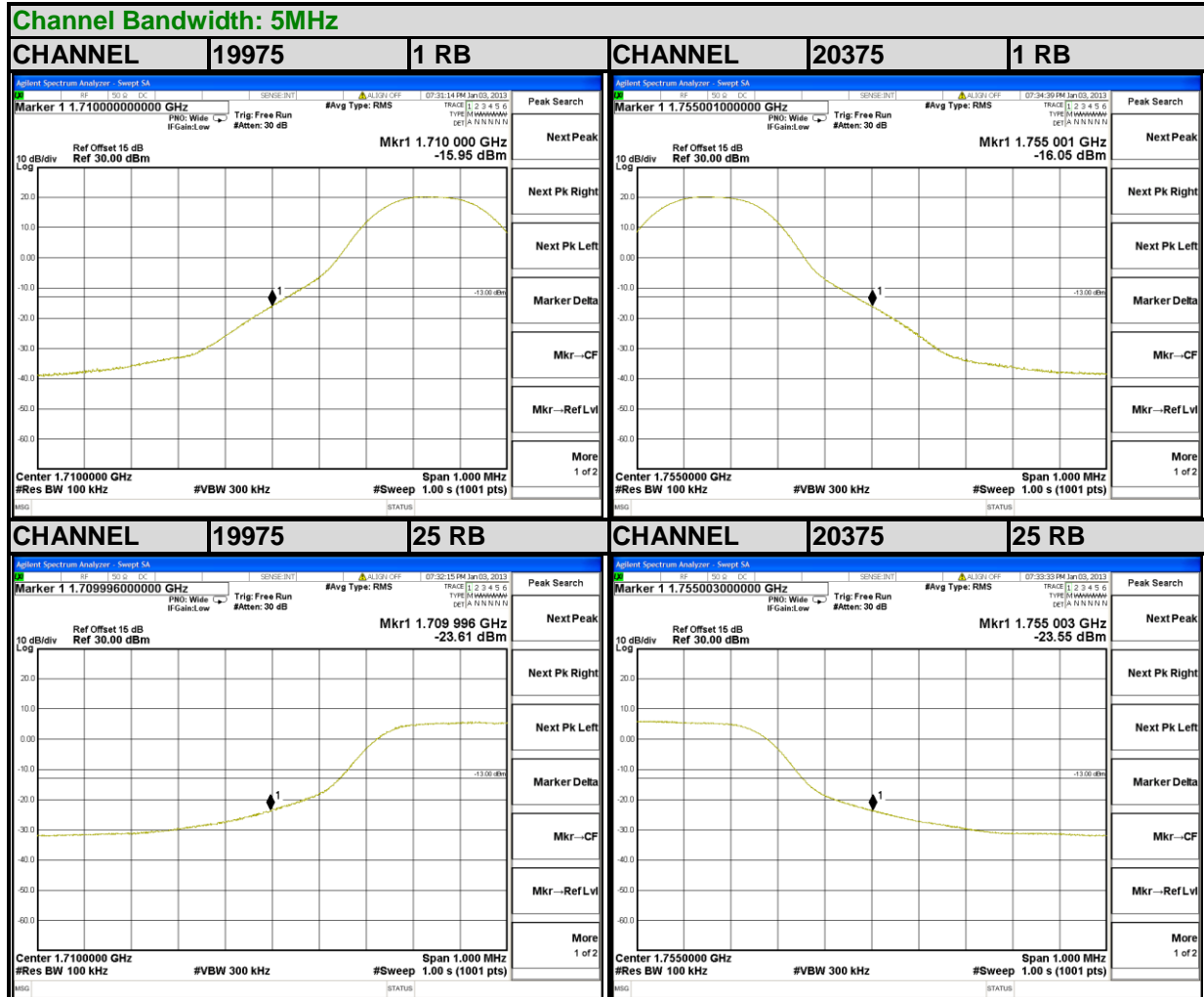

Channel Bandwidth: 10MHz

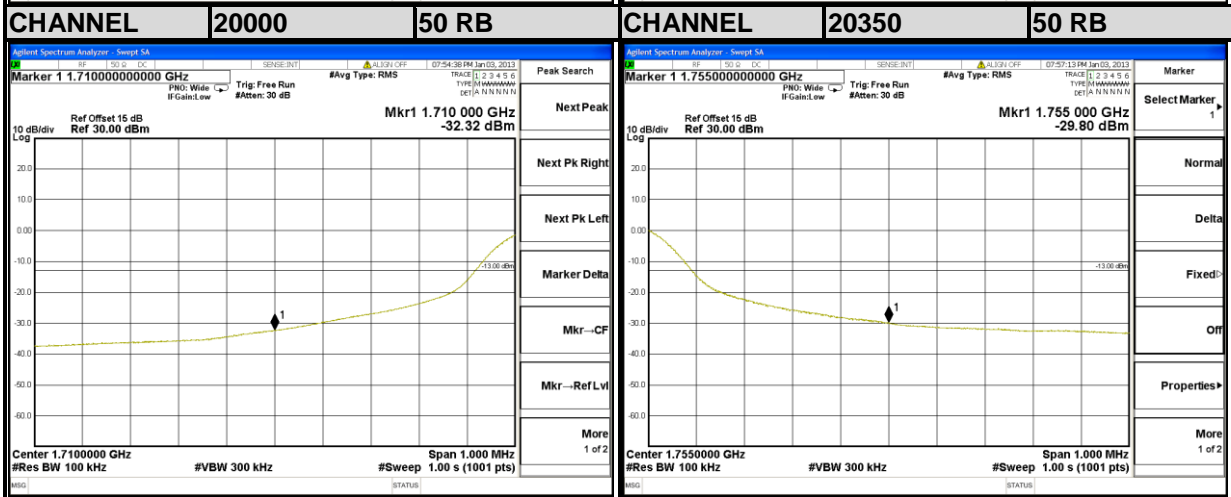
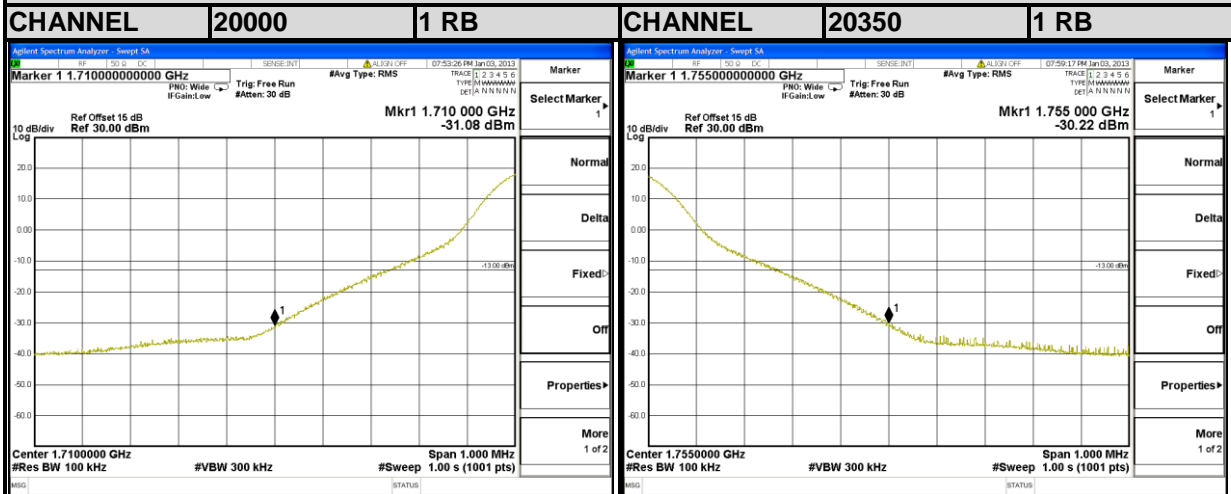



A D T

ANT.1

LTE BAND 17

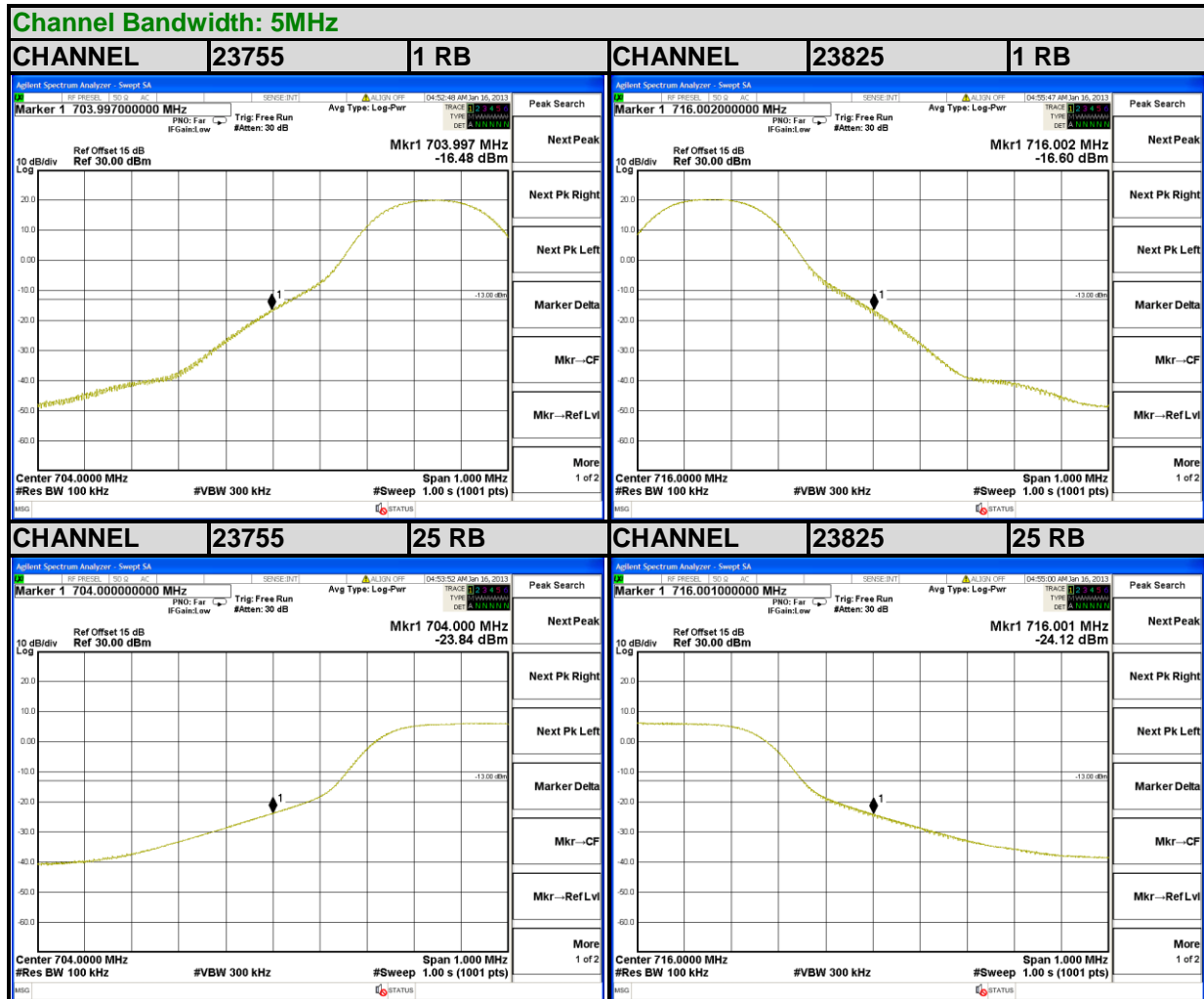



A D T

Channel Bandwidth: 10MHz

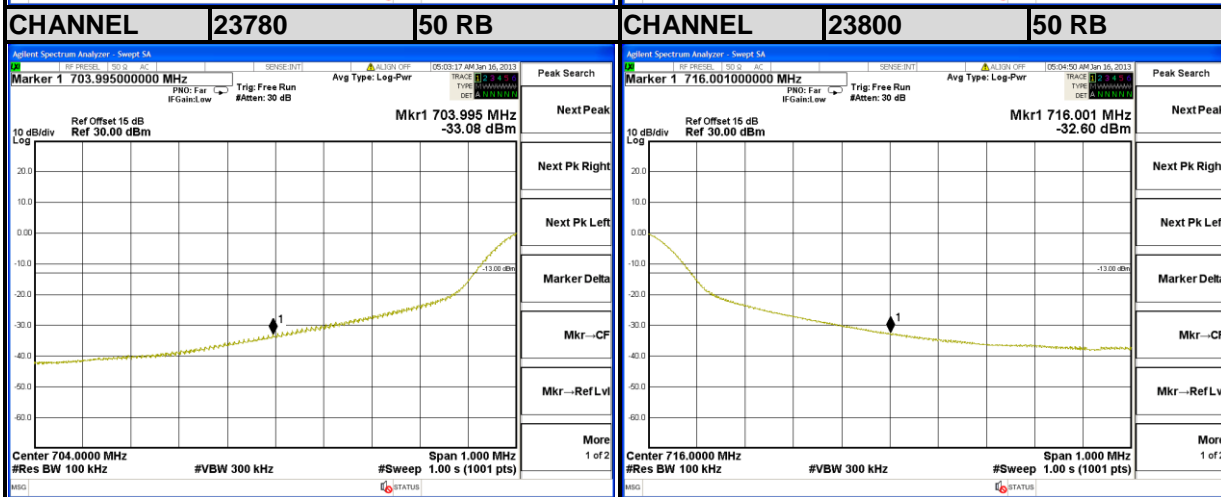
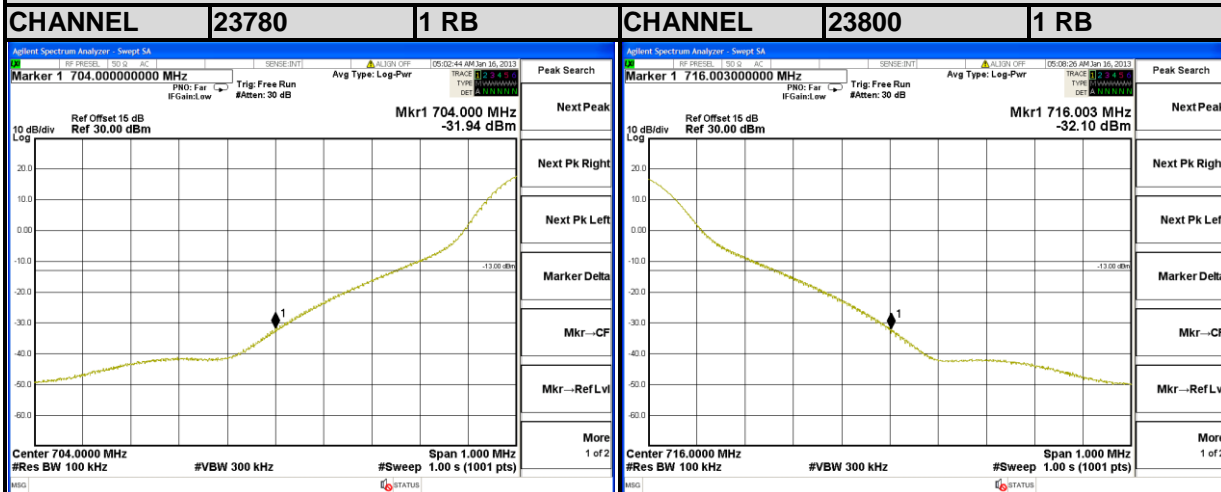



A D T

LTE BAND 4

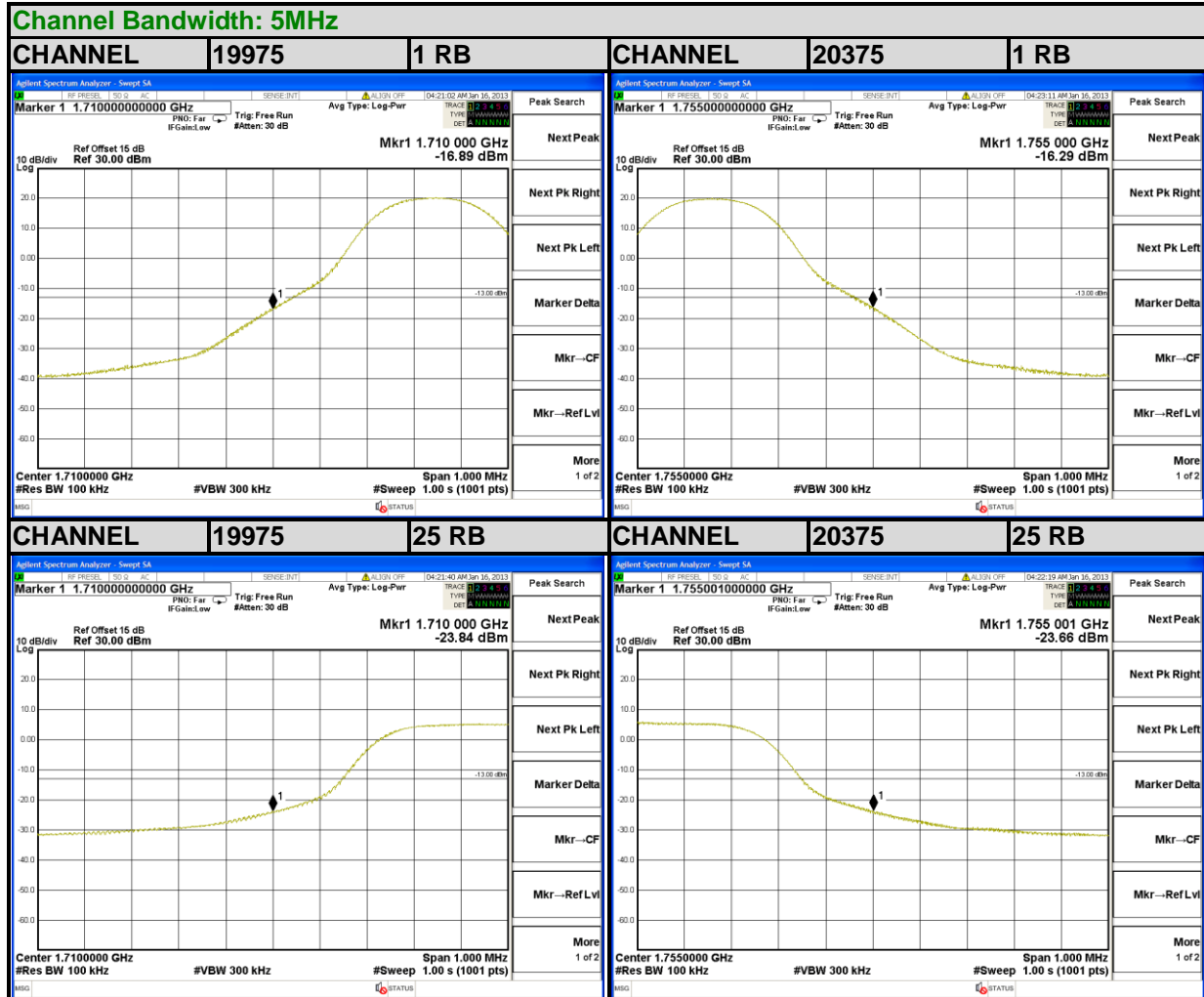



A D T

Channel Bandwidth: 10MHz

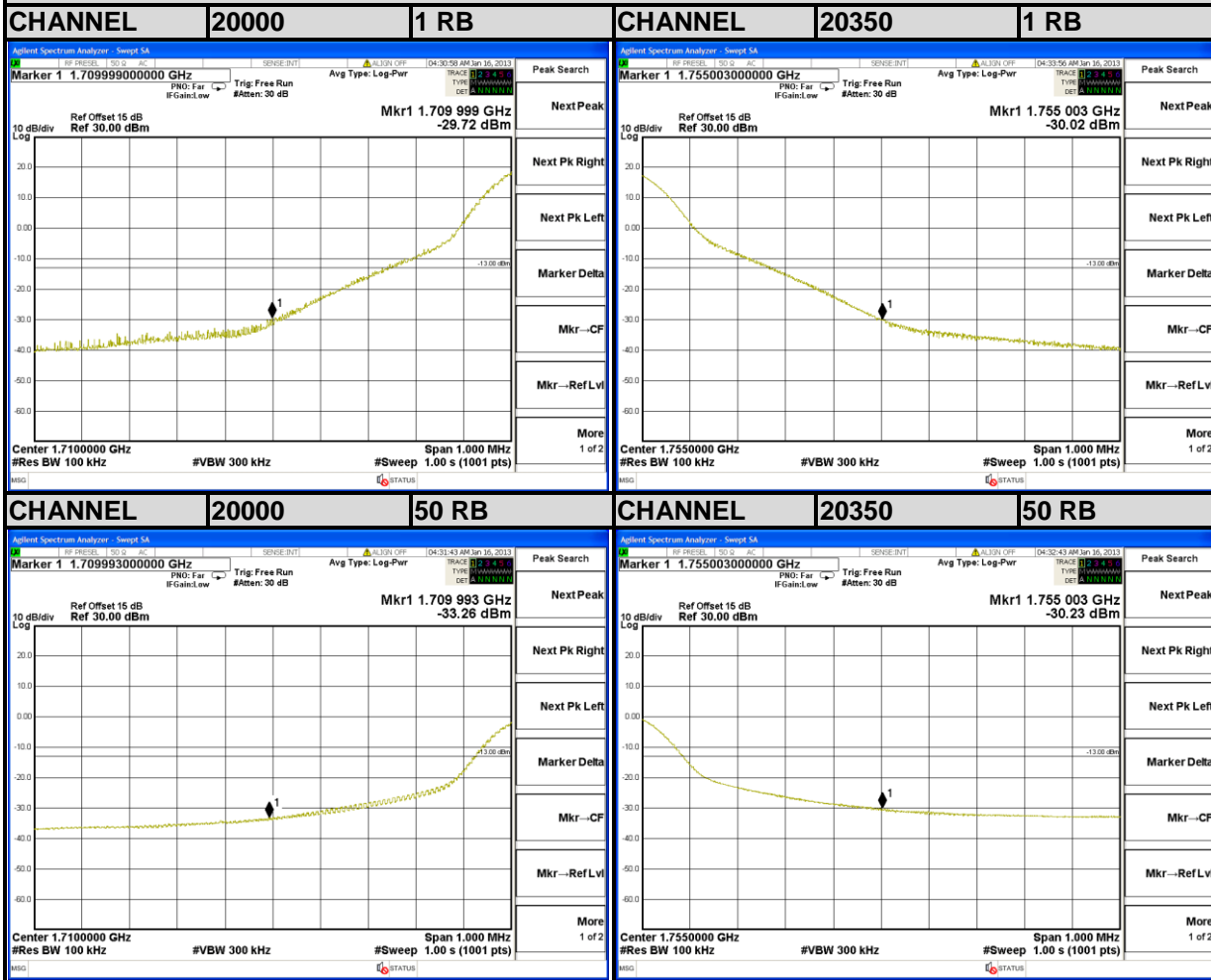

4.6 CONDUCTED SPURIOUS EMISSIONS

4.6.1 LIMITS OF CONDUCTED SPURIOUS EMISSIONS MEASUREMENT

The power of any emission outside a licensee's frequency block shall be attenuated below the transmitter power (P) by at least $43 + 10 \log_{10}(P)$ dB. The limit of emission equal to -13dBm

4.6.2 TEST PROCEDURE

- a. The EUT makes a phone call to the communication simulator. All measurements were done at low, middle and high operational frequency range.
- b. Measuring frequency range is from 30 MHz to 8GHz for LTE Band 17 and from 30MHz to 18GHz for LTE Band 4. 10dB attenuation pad is connected with spectrum. RBW=1MHz and VBW=3MHz are used for conducted emission measurement.

4.6.3 TEST SETUP

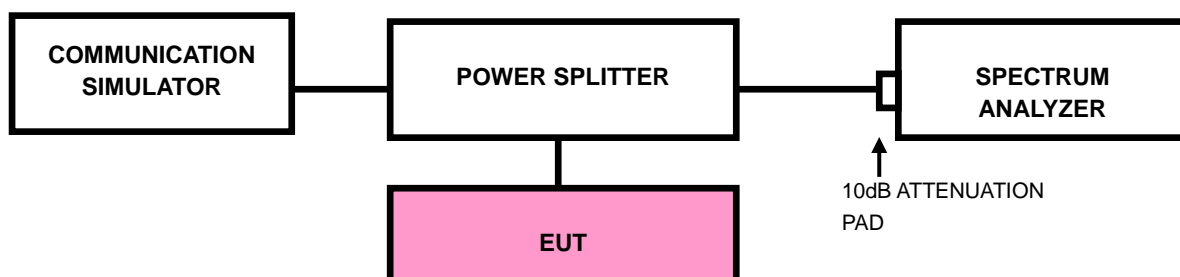

4.6.4 TEST RESULTS

ANT.0

LTE BAND 17

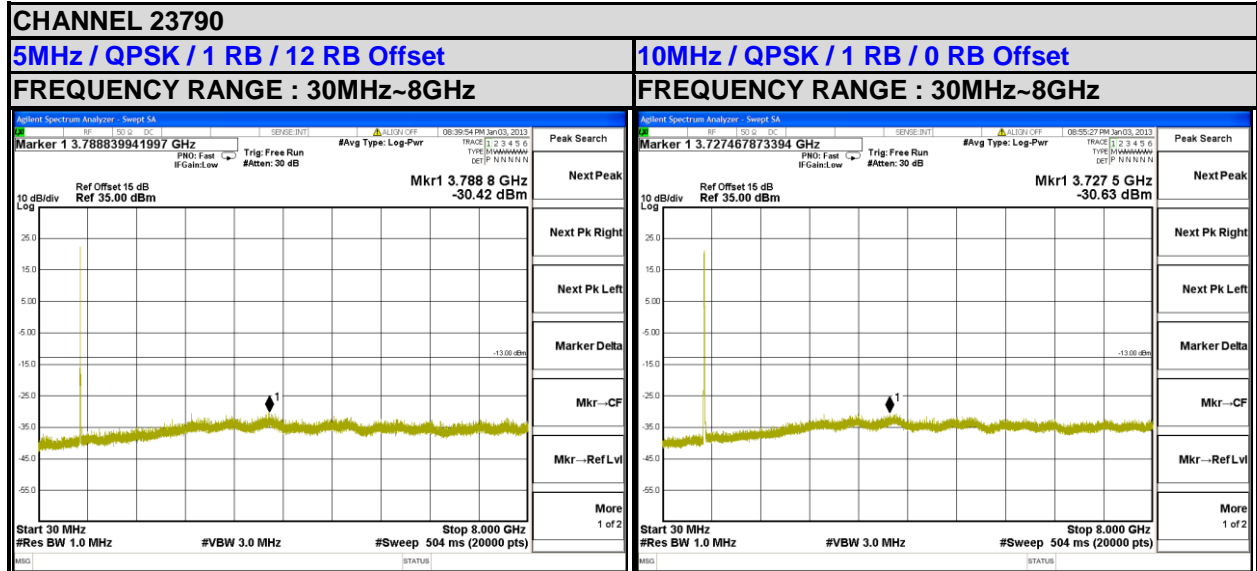

LTE BAND 4

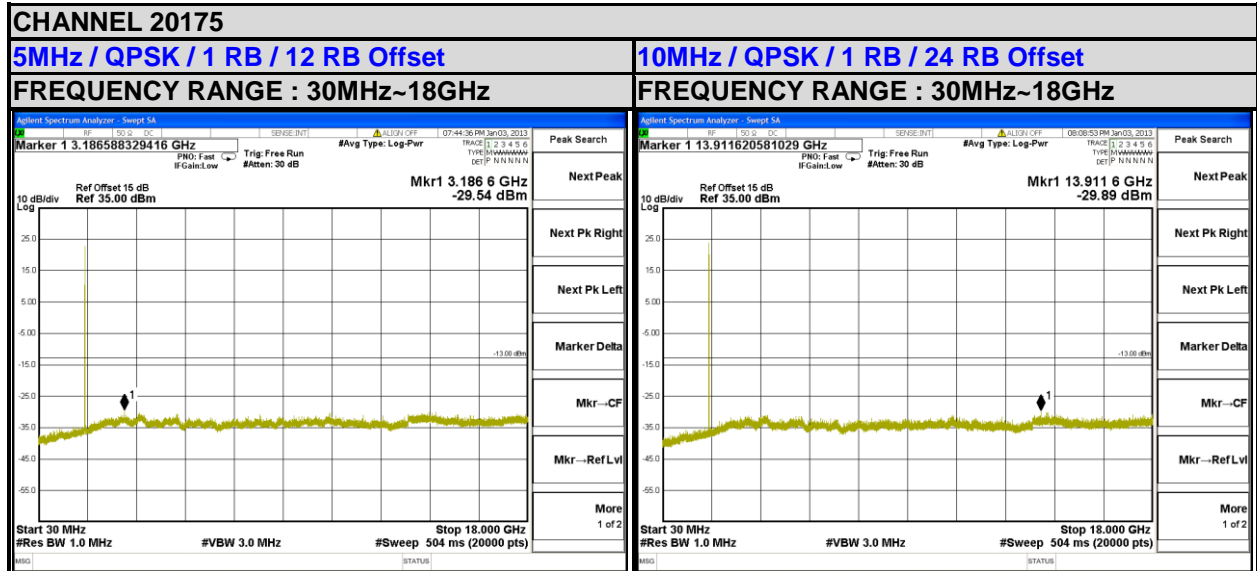

ANT.1

LTE BAND 17

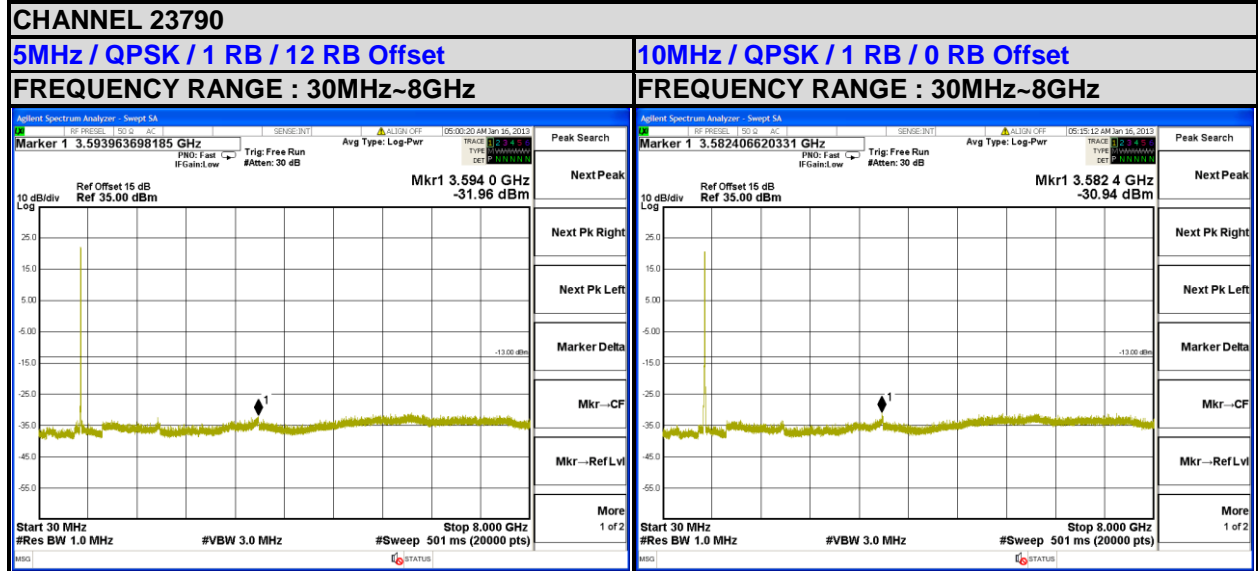

LTE BAND 4

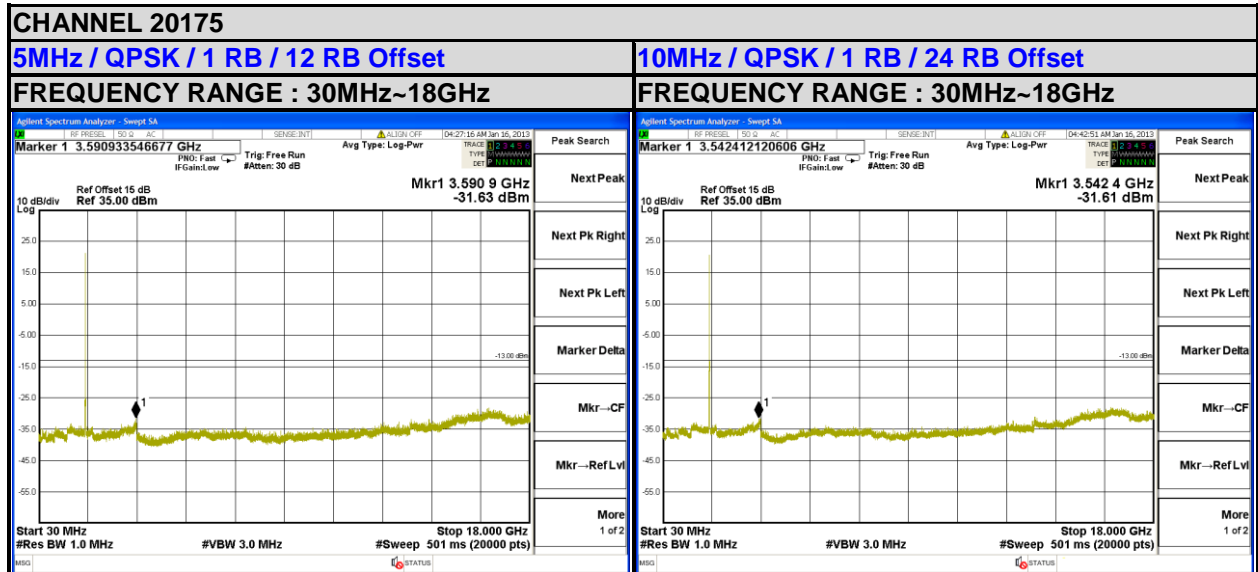

4.7 RADIATED EMISSION MEASUREMENT

4.7.1 LIMITS OF RADIATED EMISSION MEASUREMENT

The power of any emission outside a licensee's frequency block shall be attenuated below the transmitter power (P) by at least $43 + 10 \log_{10}(P)$ dB. The limit of emission equal to -13dBm

4.7.2 TEST PROCEDURES

- a. Substitution method is used for E.I.R.P measurement. In the semi-anechoic chamber, EUT placed on the 0.8m height of Turn Table, rotated the table around 360 degrees to search the maximum radiation power and receiver antenna shall be rotated vertical and horizontal polarization and moved height from 1m to 4m to find the maximum polar radiated power. The "Read Value" is the spectrum reading the maximum power value.
- b. The substitution horn antenna is substituted for EUT at the same position and signals generator export the CW signal to the substitution antenna via a TX cable. Rotated the Turn Table and moved receiving antenna to find the maximum radiation power. Adjust output power level of S.G to get a Value of spectrum reading equal to "Read Value " of step a. Record the power level of S.G
- c. $EIRP = \text{Output power level of S.G} - \text{TX cable loss} + \text{Antenna gain of substitution horn.}$
- d. E.R.P power can be calculated form E.I.R.P power by subtracting the gain of dipole, $E.R.P \text{ power} = E.I.P.R \text{ power} - 2.15\text{dBi.}$

NOTE: The resolution bandwidth of spectrum analyzer is 1 MHz and the video bandwidth is 3 MHz.

4.7.3 DEVIATION FROM TEST STANDARD

No deviation

4.7.4 TEST SETUP

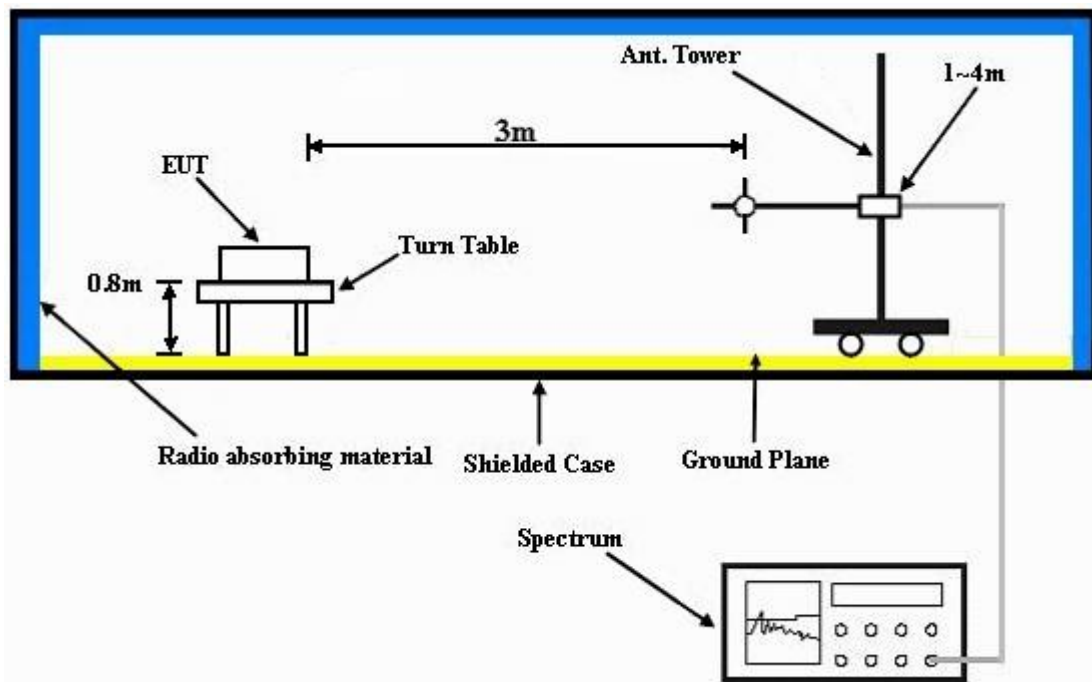

For the actual test configuration, please refer to the attached file (Test Setup Photo).

4.7.5 TEST RESULTS

ANT.0

LTE BAND 17

CHANNEL BANDWIDTH: 10MHz / QPSK

Main Sample (A)



Bureau Veritas Consumer Products Services Ltd., Taoyuan Branch

A D T

Data: 9

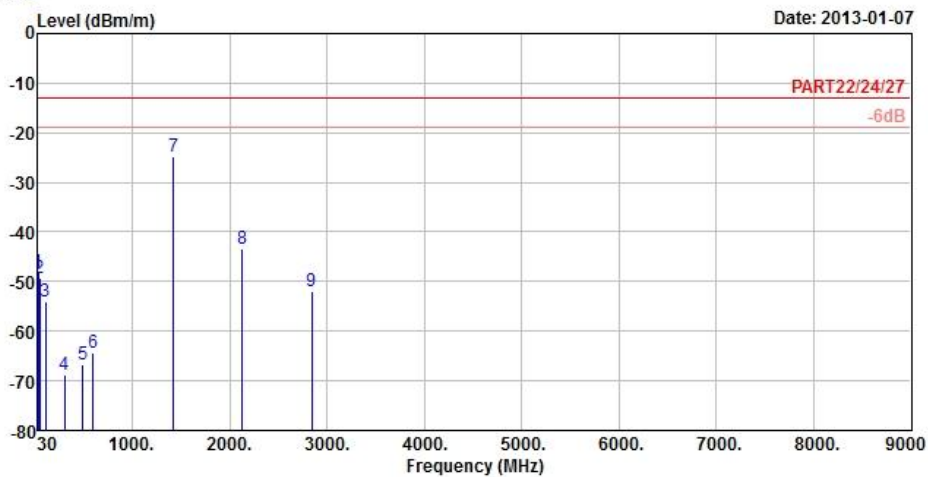

Date: 2013-01-07

Site : 966 Chamber 5
 Condition : PART22/24/27 3m HORIZONTAL
 Brand/Model: 121129C10
 Remark : LTE_Band 17_10M_QPSK(1,24)
 Tested by : Kay Wu
 Temperature : 25°C
 Humidity : 65%
 Plane : X
 ANT : ANT 0

	Read	Limit	Over			
Freq	Level	Level	Line	Limit	Factor	Remark
MHz	dBm/m	dBm	dBm/m	dB	dB/m	
1	32.43	-48.17	-47.06	-13.00	-35.17	-1.11 Peak
2	45.39	-49.32	-47.56	-13.00	-36.32	-1.76 Peak
3	109.92	-53.88	-43.27	-13.00	-40.88	-10.61 Peak
4	302.80	-68.87	-62.51	-13.00	-55.87	-6.36 Peak
5	487.60	-66.69	-63.28	-13.00	-53.69	-3.41 Peak
6	596.10	-64.25	-63.79	-13.00	-51.25	-0.46 Peak
7 pp	1420.00	-24.65	-12.14	-13.00	-11.65	-12.51 Peak
8	2130.00	-43.40	-33.04	-13.00	-30.40	-10.36 Peak
9	2840.00	-51.85	-43.75	-13.00	-38.85	-8.10 Peak



A D T



Bureau Veritas Consumer Products Services Ltd., Taoyuan Branch

A D T

Data: 10

Date: 2013-01-07

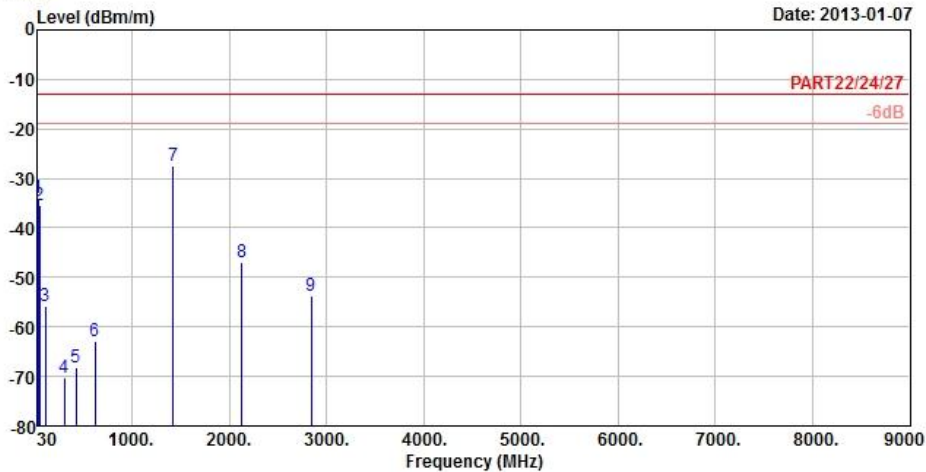

Site : 966 Chamber 5
 Condition : PART22/24/27 3m VERTICAL
 Brand/Model: 121129C10
 Remark : LTE_Band 17_10M_QPSK(1,24)
 Tested by : Kay Wu
 Temperature : 25°C
 Humidity : 65%
 Plane : X
 ANT : ANT 0

	Freq	Level	Read Level	Limit Line	Over Limit	Factor	Remark
	MHz	dBm/m	dBm	dBm/m	dB	dB/m	
1	32.70	-34.08	-32.97	-13.00	-21.08	-1.11	Peak
2	45.12	-35.30	-33.54	-13.00	-22.30	-1.76	Peak
3	108.84	-55.66	-45.07	-13.00	-42.66	-10.59	Peak
4	300.00	-70.39	-64.01	-13.00	-57.39	-6.38	Peak
5	426.70	-68.09	-63.14	-13.00	-55.09	-4.95	Peak
6	616.40	-63.01	-62.96	-13.00	-50.01	-0.05	Peak
7 pp	1420.00	-27.39	-14.88	-13.00	-14.39	-12.51	Peak
8	2130.00	-46.80	-36.44	-13.00	-33.80	-10.36	Peak
9	2840.00	-53.61	-45.51	-13.00	-40.61	-8.10	Peak



A D T

2nd Sample (B)



Bureau Veritas Consumer Products Services Ltd., Taoyuan Branch

A D T

Data: 9

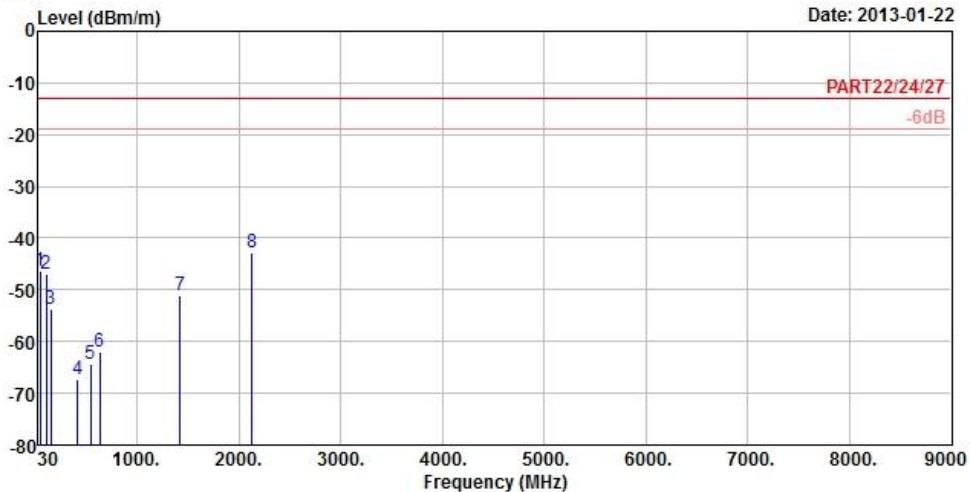

Site : 966 Chamber 5
 Condition : PART22/24/27 3m HORIZONTAL
 Brand/Model: 121129C10
 Remark : LTE_Band 17_10M_QPSK(1,24)
 Tested by : Kay Wu
 Temperature : 25°C
 Humidity : 65%
 Plane : Z
 ANT : ANT 0
 Sample : 2nd

	Freq	Level	Read Level	Limit Line	Over Limit	Factor	Remark
	MHz	dBm/m	dBm	dBm/m	dB	dB/m	
1	45.12	-46.42	-44.66	-13.00	-33.42	-1.76	Peak
2	109.65	-46.92	-36.31	-13.00	-33.92	-10.61	Peak
3	152.85	-53.65	-47.24	-13.00	-40.65	-6.41	Peak
4	416.20	-67.38	-62.16	-13.00	-54.38	-5.22	Peak
5	542.90	-64.31	-62.39	-13.00	-51.31	-1.92	Peak
6	633.90	-61.89	-62.15	-13.00	-48.89	0.26	Peak
7	1420.00	-51.19	-38.68	-13.00	-38.19	-12.51	Peak
8 pp	2130.00	-42.86	-32.50	-13.00	-29.86	-10.36	Peak



A D T



Bureau Veritas Consumer Products Services Ltd., Taoyuan Branch

A D T

Data: 10

Date: 2013-01-22

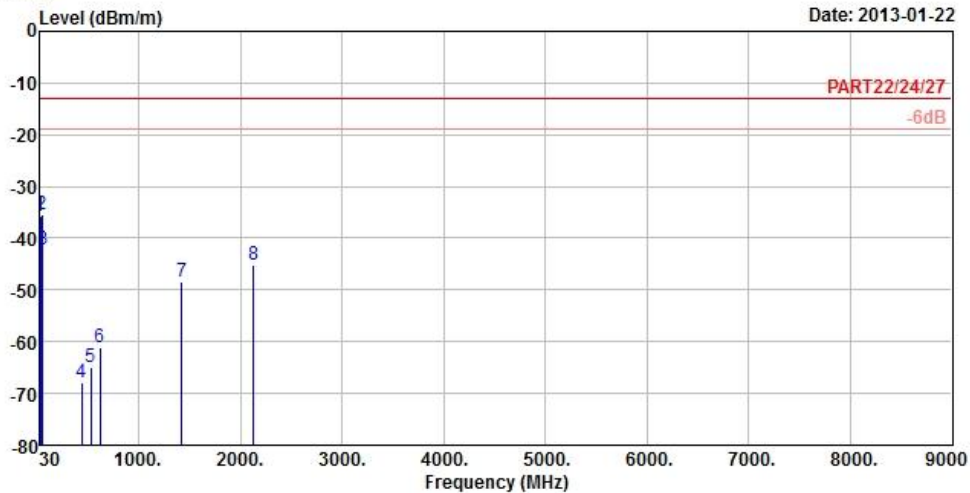

Site : 966 Chamber 5
 Condition : PART22/24/27 3m VERTICAL
 Brand/Model: 121129C10
 Remark : LTE_Band 17_10M_QPSK(1,24)
 Tested by : Kay Wu
 Temperature : 25°C
 Humidity : 65%
 Plane : Z
 ANT : ANT 0
 Sample : 2nd

	Freq	Level	Read Level	Limit Line	Over Limit	Factor	Remark
	MHz	dBm/m	dBm	dBm/m	dB	dB/m	
1	32.43	-35.67	-34.56	-13.00	-22.67	-1.11	Peak
2 pp	45.39	-35.38	-33.62	-13.00	-22.38	-1.76	Peak
3	57.27	-42.08	-36.43	-13.00	-29.08	-5.65	Peak
4	438.60	-67.79	-63.13	-13.00	-54.79	-4.66	Peak
5	528.90	-64.89	-62.57	-13.00	-51.89	-2.32	Peak
6	615.70	-61.15	-61.08	-13.00	-48.15	-0.07	Peak
7	1420.00	-48.52	-36.01	-13.00	-35.52	-12.51	Peak
8	2130.00	-45.06	-34.70	-13.00	-32.06	-10.36	Peak



A D T

LTE BAND 4

CHANNEL BANDWIDTH: 10MHz / QPSK

Main Sample (A)



Bureau Veritas Consumer Products Services Ltd., Taoyuan Branch

A D T

Data: 15

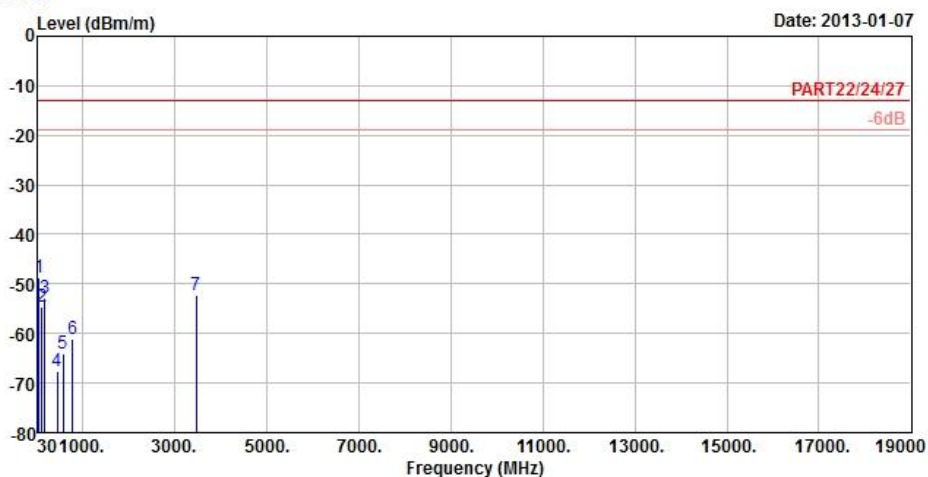

Site : 966 Chamber 5
 Condition : PART22/24/27 3m HORIZONTAL
 Brand/Model: 121129C10
 Remark : LTE_Band 4_10M_QPSK(1,24)
 Tested by : Kay Wu
 Temperature : 25°C
 Humidity : 65%
 Plane : X
 ANT : ANT 0

	Freq	Level	Read Level	Limit	Over	Factor	Remark
	MHz	dBm/m	dBm	dBm/m	dB	dB/m	
1	pp	43.50	-48.64	-47.38	-13.00	-35.64	-1.26 Peak
2		110.73	-54.51	-43.88	-13.00	-41.51	-10.63 Peak
3		180.12	-52.94	-47.27	-13.00	-39.94	-5.67 Peak
4		447.00	-67.70	-63.26	-13.00	-54.70	-4.44 Peak
5		580.00	-63.98	-63.07	-13.00	-50.98	-0.91 Peak
6		778.10	-61.07	-63.05	-13.00	-48.07	1.98 Peak
7		3465.00	-52.29	-44.66	-13.00	-39.29	-7.63 Peak



A D T



Bureau Veritas Consumer Products Services Ltd., Taoyuan Branch

A D T

Data: 16

Date: 2013-01-07

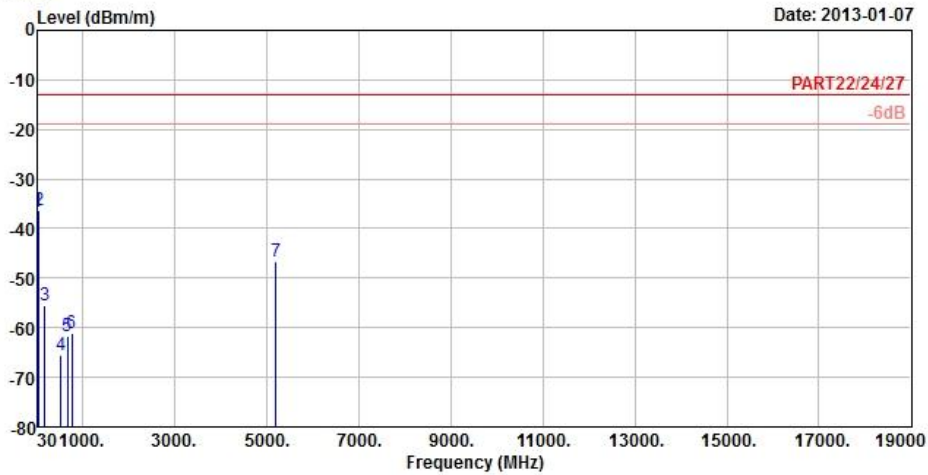

Site : 966 Chamber 5
 Condition : PART22/24/27 3m VERTICAL
 Brand/Model: 121129C10
 Remark : LTE_Band 4_10M_QPSK(1,24)
 Tested by : Kay Wu
 Temperature : 25°C
 Humidity : 65%
 Plane : X
 ANT : ANT 0

	Freq	Level	Read	Limit	Over	
	MHz	dBm/m	Level	Line	Limit	Factor Remark
			dBm	dBm/m	dB	dB/m
1	30.27	-36.69	-37.76	-13.00	-23.69	1.07 Peak
2 pp	43.77	-36.31	-35.05	-13.00	-23.31	-1.26 Peak
3	179.31	-55.39	-49.53	-13.00	-42.39	-5.86 Peak
4	534.50	-65.64	-63.48	-13.00	-52.64	-2.16 Peak
5	666.10	-61.79	-62.63	-13.00	-48.79	0.84 Peak
6	765.50	-61.19	-63.08	-13.00	-48.19	1.89 Peak
7	5197.50	-46.58	-45.50	-13.00	-33.58	-1.08 Peak



A D T

2nd Sample (B)



Bureau Veritas Consumer Products Services Ltd., Taoyuan Branch

A D T

Data: 15

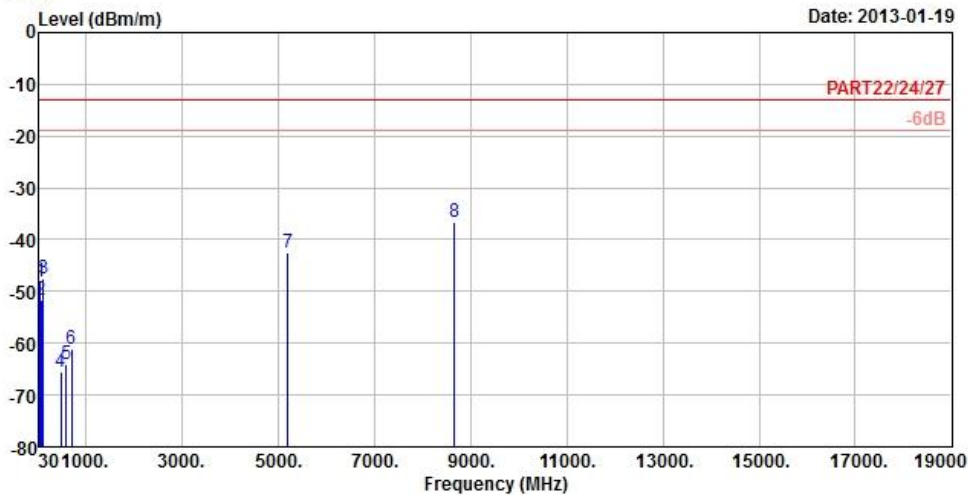

Site : 966 Chamber 5
 Condition : PART22/24/27 3m HORIZONTAL
 Brand/Model: 121129C10
 Remark : LTE_Band 4_10M_QPSK(1,24)
 Tested by : Kay Wu
 Temperature : 25°C
 Humidity : 65%
 Plane : Y
 ANT : ANT 0
 Sample : 2nd

	Freq	Level	Read Level	Limit Line	Over Limit	Factor	Remark
	MHz	dBm/m	dBm	dBm/m	dB	dB/m	
1	44.31	-48.25	-47.06	-13.00	-35.25	-1.19	Peak
2	69.15	-51.56	-42.54	-13.00	-38.56	-9.02	Peak
3	106.68	-47.57	-37.02	-13.00	-34.57	-10.55	Peak
4	479.90	-65.68	-62.08	-13.00	-52.68	-3.60	Peak
5	584.20	-63.98	-63.18	-13.00	-50.98	-0.80	Peak
6	696.90	-61.16	-62.56	-13.00	-48.16	1.40	Peak
7	5197.50	-42.62	-41.54	-13.00	-29.62	-1.08	Peak
8 pp	8662.50	-36.71	-45.04	-13.00	-23.71	8.33	Peak



A D T



Bureau Veritas Consumer Products Services Ltd., Taoyuan Branch

A D T

Data: 16

Date: 2013-01-19

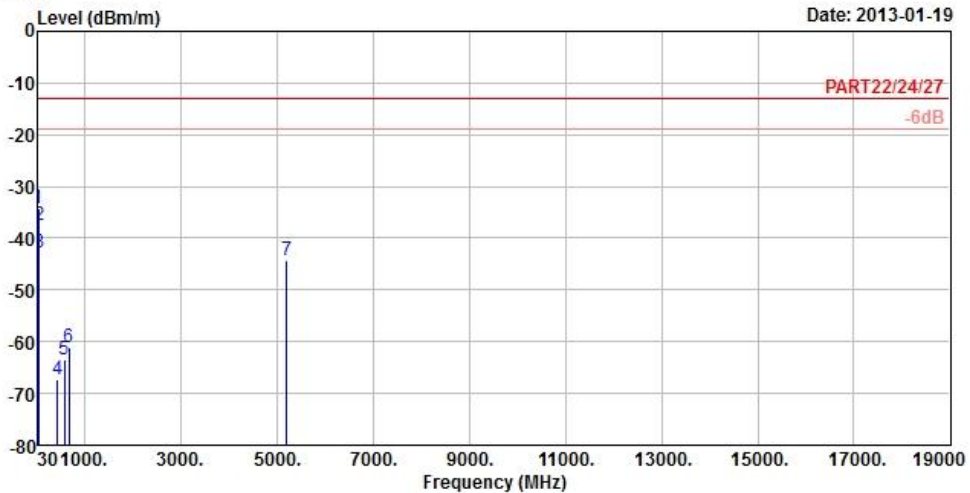

Site : 966 Chamber 5
 Condition : PART22/24/27 3m VERTICAL
 Brand/Model: 121129C10
 Remark : LTE_Band 4_10M_QPSK(1,24)
 Tested by : Kay Wu
 Temperature : 25°C
 Humidity : 65%
 Plane : Y
 ANT : ANT 0
 Sample : 2nd

	Freq	Level	Read Level	Limit Line	Over Limit	Factor	Remark
	MHz	dBm/m	dBm	dBm/m	dB	dB/m	
1 pp	30.00	-34.19	-35.26	-13.00	-21.19	1.07	Peak
2	43.77	-37.46	-36.20	-13.00	-24.46	-1.26	Peak
3	56.19	-42.73	-37.23	-13.00	-29.73	-5.50	Peak
4	437.90	-67.37	-62.71	-13.00	-54.37	-4.66	Peak
5	567.40	-63.49	-62.24	-13.00	-50.49	-1.25	Peak
6	674.50	-61.23	-62.21	-13.00	-48.23	0.98	Peak
7	5197.50	-44.19	-43.11	-13.00	-31.19	-1.08	Peak



A D T

ANT.1

LTE BAND 17

CHANNEL BANDWIDTH: 10MHz / QPSK



Bureau Veritas Consumer Products Services Ltd., Taoyuan Branch

A D T

Data: 9

Date: 2013-01-05

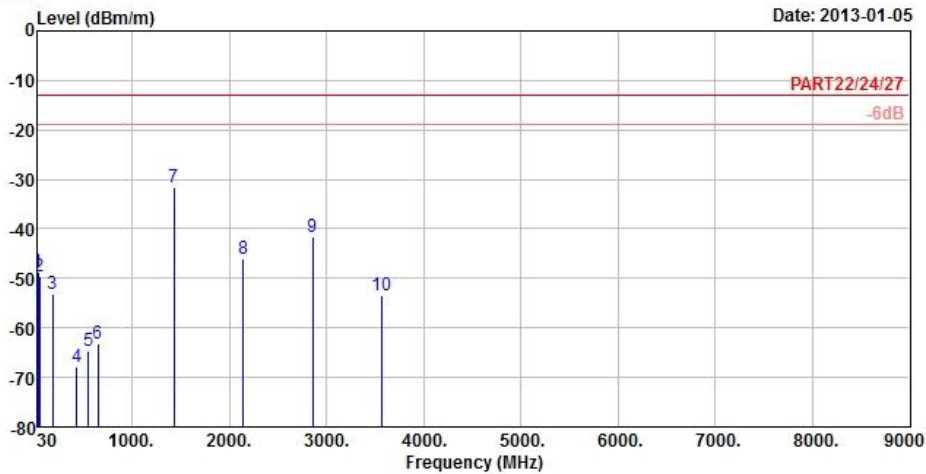

Site : 966 Chamber 5
 Condition : PART22/24/27 3m HORIZONTAL
 Brand/Model: 121129C10
 Remark : LTE_Band 17_10M_QPSK(1,49)
 Tested by : Kay Wu
 Temperature : 25°C
 Humidity : 65%
 Plane : X
 ANT : ANT 1

	Read	Limit	Over				
Freq	Level	Level	Line	Limit	Factor	Remark	
MHz	dBm/m	dBm	dBm/m	dB	dB/m		
1	32.70	-48.71	-47.60	-13.00	-35.71	-1.11	Peak
2	45.12	-49.49	-47.73	-13.00	-36.49	-1.76	Peak
3	180.12	-53.13	-47.46	-13.00	-40.13	-5.67	Peak
4	428.10	-67.79	-62.86	-13.00	-54.79	-4.93	Peak
5	551.30	-64.76	-63.05	-13.00	-51.76	-1.71	Peak
6	649.30	-63.04	-63.56	-13.00	-50.04	0.52	Peak
7 pp	1428.80	-31.63	-19.11	-13.00	-18.63	-12.52	Peak
8	2143.20	-46.03	-35.76	-13.00	-33.03	-10.27	Peak
9	2857.60	-41.48	-33.34	-13.00	-28.48	-8.14	Peak
10	3572.00	-53.50	-46.29	-13.00	-40.50	-7.21	Peak



A D T



Bureau Veritas Consumer Products Services Ltd., Taoyuan Branch

A D T

Data: 10

Date: 2013-01-05

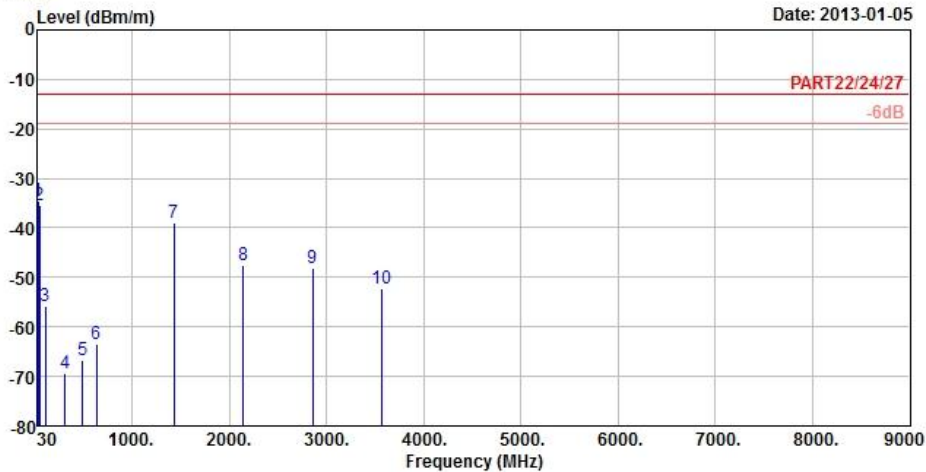

Site : 966 Chamber 5
 Condition : PART22/24/27 3m VERTICAL
 Brand/Model: 121129C10
 Remark : LTE_Band 17_10M_QPSK(1,49)
 Tested by : Kay Wu
 Temperature : 25°C
 Humidity : 65%
 Plane : X
 ANT : ANT 1

	Freq	Level	Read Level	Limit	Over	Factor	Remark
	MHz	dBm/m	dBm	dBm/m	dB	dB/m	
1	pp	32.97	-34.45	-33.34	-13.00	-21.45	-1.11 Peak
2		45.39	-35.29	-33.53	-13.00	-22.29	-1.76 Peak
3		109.92	-55.67	-45.06	-13.00	-42.67	-10.61 Peak
4		309.10	-69.49	-63.18	-13.00	-56.49	-6.31 Peak
5		493.20	-66.69	-63.43	-13.00	-53.69	-3.26 Peak
6		633.20	-63.38	-63.62	-13.00	-50.38	0.24 Peak
7		1428.80	-39.00	-26.48	-13.00	-26.00	-12.52 Peak
8		2143.20	-47.50	-37.23	-13.00	-34.50	-10.27 Peak
9		2857.60	-48.04	-39.90	-13.00	-35.04	-8.14 Peak
10		3572.00	-52.28	-45.07	-13.00	-39.28	-7.21 Peak



A D T

LTE BAND 4

CHANNEL BANDWIDTH: 10MHz / QPSK



Bureau Veritas Consumer Products Services Ltd., Taoyuan Branch

A D T

Data: 15

Date: 2013-01-07

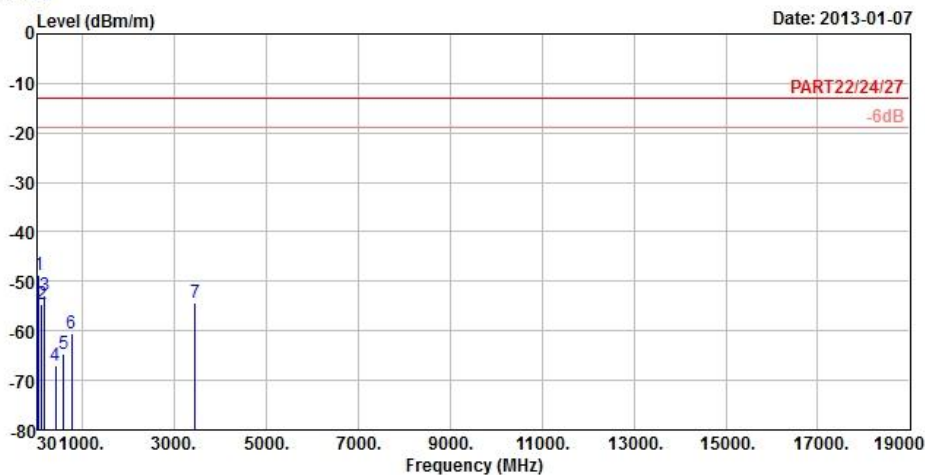

Site : 966 Chamber 5
 Condition : PART22/24/27 3m HORIZONTAL
 Brand/Model: 121129C10
 Remark : LTE_Band 4_10M_QPSK(1,0)
 Tested by : Kay Wu
 Temperature : 25°C
 Humidity : 65%
 Plane : Z
 ANT : ANT 1

	Freq	Level	Read Level	Limit	Over	Factor	Remark
	MHz	dBm/m	dBm	dBm/m	dB	dB/m	
1	44.04	-48.73	-47.47	-13.00	-35.73	-1.26	Peak
2	111.54	-54.64	-43.99	-13.00	-41.64	-10.65	Peak
3	179.31	-52.81	-46.95	-13.00	-39.81	-5.86	Peak
4	421.10	-66.87	-61.77	-13.00	-53.87	-5.10	Peak
5	586.30	-64.56	-63.84	-13.00	-51.56	-0.72	Peak
6	767.60	-60.52	-62.43	-13.00	-47.52	1.91	Peak
7	3456.20	-54.19	-46.53	-13.00	-41.19	-7.66	Peak



A D T



Bureau Veritas Consumer Products Services Ltd., Taoyuan Branch

A D T

Data: 16

Date: 2013-01-07

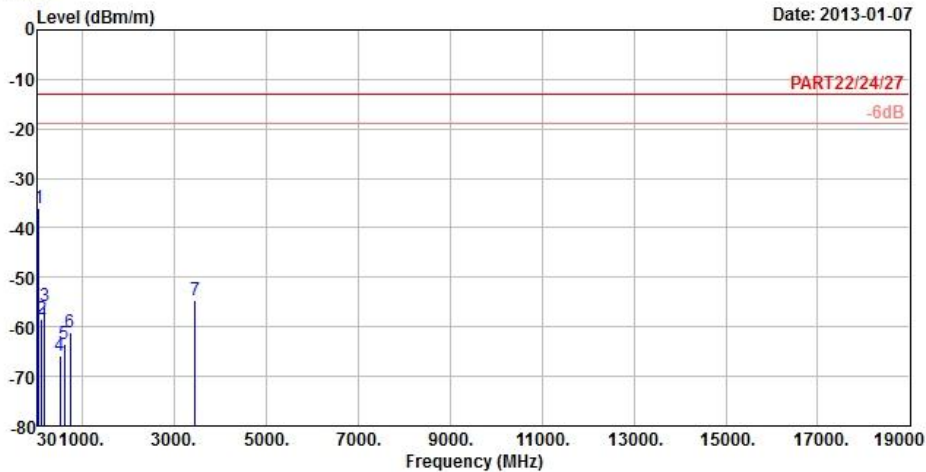

Site : 966 Chamber 5
 Condition : PART22/24/27 3m VERTICAL
 Brand/Model: 121129C10
 Remark : LTE_Band 4_10M_QPSK(1,0)
 Tested by : Kay Wu
 Temperature : 25°C
 Humidity : 65%
 Plane : Z
 ANT : ANT 1

	Freq	Level	Read Level	Limit Line	Over Limit	Factor	Remark
	MHz	dBm/m	dBm	dBm/m	dB	dB/m	
1	pp	44.31	-35.87	-34.68	-13.00	-22.87	-1.19 Peak
2		108.84	-58.31	-47.72	-13.00	-45.31	-10.59 Peak
3		179.85	-55.72	-49.86	-13.00	-42.72	-5.86 Peak
4		515.60	-65.97	-63.31	-13.00	-52.97	-2.66 Peak
5		605.90	-63.41	-63.16	-13.00	-50.41	-0.25 Peak
6		736.80	-61.19	-62.89	-13.00	-48.19	1.70 Peak
7		3456.20	-54.50	-46.84	-13.00	-41.50	-7.66 Peak

5 INFORMATION ON THE TESTING LABORATORIES

We, Bureau Veritas Consumer Products Services (H.K.) Ltd., Taoyuan Branch, were founded in 1988 to provide our best service in EMC, Radio, Telecom and Safety consultation. Our laboratories are accredited and approved according to ISO/IEC 17025.

If you have any comments, please feel free to contact us at the following:

Linko EMC/RF Lab:

Tel: 886-2-26052180

Fax: 886-2-26051924

Hsin Chu EMC/RF Lab:

Tel: 886-3-5935343

Fax: 886-3-5935342

Hwa Ya EMC/RF/Safety/Telecom Lab:

Tel: 886-3-3183232

Fax: 886-3-3270892

Email: service.adt@tw.bureauveritas.com

Web Site: www.adt.com.tw

The address and road map of all our labs can be found in our web site also.

6 APPENDIX A – MODIFICATIONS RECORDERS FOR ENGINEERING CHANGES TO THE EUT BY THE LAB

No modifications were made to the EUT by the lab during the test.

---END---