



# FCC SAR Test Report

**APPLICANT** : HTC Corporation  
**EQUIPMENT** : Smartphone  
**MODEL NAME** : PM35110  
**FCC ID** : NM8PM35110  
**STANDARD** : FCC 47 CFR Part 2 (2.1093)  
ANSI/IEEE C95.1-1992  
IEEE 1528-2003  
FCC OET Bulletin 65 Supplement C (Edition 01-01)

The product was completely tested on Sep. 05, 2012. We, SPORTON INTERNATIONAL INC., would like to declare that the tested sample has been evaluated in accordance with the procedures and shown the compliance with the applicable technical standards.

The test results in this report apply exclusively to the tested model / sample. Without written approval of SPORTON INTERNATIONAL INC., the test report shall not be reproduced except in full.

Reviewed by:

Jones Tsai / Manager



**SPORTON INTERNATIONAL INC.**

No. 52, Hwa Ya 1<sup>st</sup> Rd., Hwa Ya Technology Park, Kwei-Shan Hsiang, Tao Yuan Hsien, Taiwan, R.O.C.



Table of Contents

1. Statement of Compliance ..... 4
2. Administration Data ..... 5
2.1 Testing Laboratory ..... 5
2.2 Applicant ..... 5
2.3 Manufacturer ..... 5
2.4 Application Details ..... 5
3. General Information ..... 6
3.1 Description of Equipment Under Test (EUT) ..... 6
3.2 Applied Standard ..... 8
3.3 Device Category and SAR Limits ..... 8
3.4 Test Conditions ..... 8
4. Specific Absorption Rate (SAR) ..... 9
4.1 Introduction ..... 9
4.2 SAR Definition ..... 9
5. SAR Measurement System ..... 10
5.1 E-Field Probe ..... 11
5.2 Data Acquisition Electronics (DAE) ..... 12
5.3 Robot ..... 12
5.4 Measurement Server ..... 12
5.5 Phantom ..... 13
5.6 Device Holder ..... 14
5.7 Data Storage and Evaluation ..... 15
5.8 Test Equipment List ..... 17
6. Tissue Simulating Liquids ..... 18
7. SAR Measurement Evaluation ..... 20
7.1 Purpose of System Performance check ..... 20
7.2 System Setup ..... 20
7.3 Validation Results ..... 22
8. EUT Testing Position ..... 23
8.1 Define two imaginary lines on the handset ..... 23
8.2 Cheek Position ..... 24
8.3 Tilted Position ..... 24
8.4 Body Worn Position ..... 25
9. Measurement Procedures ..... 26
9.1 Spatial Peak SAR Evaluation ..... 26
9.2 Area & Zoom Scan Procedures ..... 26
9.3 Volume Scan Procedures ..... 27
9.4 SAR Averaged Methods ..... 27
9.5 Power Drift Monitoring ..... 27
10. SAR Test Configurations ..... 28
10.1 Exposure Positions Consideration ..... 28
10.2 Conducted RF Output Power (Unit: dBm) ..... 30
11. SAR Test Results ..... 36
11.1 Test Records for Head SAR Test ..... 36
11.2 Test Records for Hotspot SAR Test ..... 38
11.3 Test Records for Body-worn SAR Test ..... 41
11.4 Simultaneous Multi-band Transmission Analysis ..... 43
11.5 Simultaneous analysis - SPLSR calculation ..... 47
12. Uncertainty Assessment ..... 48
13. References ..... 51

- Appendix A. Plots of System Performance Check
Appendix B. Plots of SAR Measurement
Appendix C. DASYS Calibration Certificate
Appendix D. Test Setup Photos



### Revision History

REPORT NO.	VERSION	DESCRIPTION	ISSUED DATE
FA2808181-01	Rev. 01	Initial issue of report	Sep. 24, 2012



### 1. Statement of Compliance

The maximum results of Specific Absorption Rate (SAR) found during testing for **HTC Corporation Smartphone PM35110** are as follows.

**<Standalone SAR>**

Band	Position	SAR <sub>1g</sub> (W/kg)
GSM850	Head	0.213
GSM1900	Head	0.669
WCDMA Band V	Head	0.15
WCDMA Band II	Head	0.653
WLAN 2.4G	Head	0.634
WLAN 5G	Head	0.144
GSM850	Hotspot (1 cm Gap)	0.364
GSM1900	Hotspot (1 cm Gap)	1.31
WCDMA Band V	Hotspot (1 cm Gap)	0.272
WCDMA Band II	Hotspot (1 cm Gap)	1.1
WLAN 2.4G	Hotspot (1 cm Gap)	0.178
WLAN 5G	Hotspot (1 cm Gap)	0.266
GSM850	Body-worn (1 cm Gap)	0.361
GSM1900	Body-worn (1 cm Gap)	1.31
WCDMA Band V	Body-worn (1 cm Gap)	0.272
WCDMA Band II	Body-worn (1 cm Gap)	1.1
WLAN 2.4G	Body-worn (1 cm Gap)	0.178
WLAN 5G	Body-worn (1 cm Gap)	0.276

This device is in compliance with Specific Absorption Rate (SAR) for general population/uncontrolled exposure limits (1.6 W/kg) specified in FCC 47 CFR part 2 (2.1093) and ANSI/IEEE C95.1-1992, and had been tested in accordance with the measurement methods and procedures specified in IEEE 1528-2003 and FCC OET Bulletin 65 Supplement C (Edition 01-01).



## 2. Administration Data

### 2.1 Testing Laboratory

Test Site	SPORTON INTERNATIONAL INC.
Test Site Location	No. 52, Hwa Ya 1 <sup>st</sup> Rd., Hwa Ya Technology Park, Kwei-Shan Hsiang, Tao Yuan Hsien, Taiwan, R.O.C. TEL: +886-3-327-3456 FAX: +886-3-328-4978

### 2.2 Applicant

Company Name	HTC Corporation
Address	No. 23, Xinghua Rd., Taoyuan City, Taoyuan County 330, Taiwan

### 2.3 Manufacturer

Company Name	HTC Corporation
Address	No. 23, Xinghua Rd., Taoyuan City, Taoyuan County 330, Taiwan

### 2.4 Application Details

Date of Start during the Test	Aug. 19, 2012
Date of End during the Test	Sep. 05, 2012



**3. General Information**

**3.1 Description of Equipment Under Test (EUT)**

Product Feature & Specification	
EUT	Smartphone
Model Name	PM35110
FCC ID	NM8PM35110
IMEI Code	Main: 353567050018226 2nd: 353567050022970
Sample 1	EUT with LCM 1, Camera Front 1, Camera Main 1, DDR Memory 1, and Battery 1
Sample 2	EUT with LCM 2, Camera Front 1, Camera Main 2, DDR Memory 2, and Battery 2
Sample 3	EUT with LCM 1, Camera Front 1, Camera Main 1, DDR Memory 3, and Battery 1
Sample 4	EUT with LCM 2, Camera Front 2, Camera Main 2, DDR Memory 3, and Battery 2
Tx Frequency	GSM850: 824.2 MHz ~ 848.8 MHz GSM1900: 1850.2 MHz ~ 1909.8 MHz WCDMA Band V: 826.4 MHz ~ 846.6 MHz WCDMA Band II: 1852.4 MHz ~ 1907.6 MHz WLAN2.4G: 2412 MHz ~ 2462 MHz WLAN5G: 5180 MHz ~ 5240 MHz; 5260 MHz ~ 5320 MHz; 5500 MHz ~ 5700 MHz; 5745 MHz ~ 5825 MHz Bluetooth: 2402 MHz ~ 2480 MHz NFC : 13.56 MHz
Rx Frequency	GSM850: 869.2 MHz ~ 893.8 MHz GSM1900: 1930.2 MHz ~ 1989.8 MHz WCDMA Band V: 871.4 MHz ~ 891.6 MHz WCDMA Band II: 1932.4 MHz ~ 1987.6 MHz WLAN2.4G: 2412 MHz ~ 2462 MHz WLAN5G: 5180 MHz ~ 5240 MHz; 5260 MHz ~ 5320 MHz; 5500 MHz ~ 5700 MHz; 5745 MHz ~ 5825 MHz Bluetooth: 2402 MHz ~ 2480 MHz NFC : 13.56 MHz
Maximum Average Output Power to Antenna	GSM850: 32.79 dBm GSM1900: 30.30 dBm WCDMA Band V: 23.58 dBm WCDMA Band II: 23.46 dBm 802.11b: 18.29 dBm 802.11g: 16.72 dBm 802.11n-HT20 (2.4GHz) : 17.43 dBm 802.11n-HT40 (2.4GHz) : 15.57 dBm 802.11a: 15.67 dBm 802.11n-HT20 (5GHz) : 14.69 dBm 802.11n-HT40 (5GHz) : 13.93 dBm Bluetooth: 7.61 dBm



Product Feature & Specification	
Antenna Type	WWAN: PIFA Antenna WLAN: PIFA Antenna Bluetooth: PIFA Antenna NFC: Loop Antenna
Uplink Modulations	GSM: GMSK GPRS: GMSK EDGE: GMSK / 8PSK WCDMA (Rel 99): QPSK HSDPA (Rel 6): QPSK HSUPA (Rel 6) : QPSK 802.11b: DSSS (BPSK / QPSK / CCK) 802.11a/g/n: OFDM (BPSK / QPSK / 16QAM / 64QAM) Bluetooth : GFSK Bluetooth EDR : $\pi/4$ -DQPSK, 8-DPSK NFC : ASK
Dual Transfer Mode (DTM) Category	Class A – EUT can support Packet Switched and Circuit Switched Network simultaneously.
EUT Stage	Production Unit
<b>Remark:</b> 1. The above EUT's information was declared by manufacturer. Please refer to the specifications or user's manual for more detailed description. 2. 5600 MHz ~ 5650 MHz is notched. 3. SAR testing only use sample 1 and sample 2. For sample 3 and sample 4, the only difference is is the manufacturer of the camera (front) and DDR memory, which does not affect the SAR measurement.	

Per KDB 941225 D04 requirement, the required test configuration for this device is as below:

1. This EUT is class A device
2. This EUT supports (E)GPRS multi-slot class 12 (max. uplink : 4, max. downlink : 4, total timeslots : 5)
3. This EUT supports DTM multi-slot class 11 (max. uplink : 3 for 1 CS & 2 PS, max. downlink : 4, total timeslots : 5)
4. The measured maximum conducted power can be referred to section 10.2 of this report
5. For DTM multi-slot class 11 link mode, the device was linked with system emulator (Agilent E5515C) and transmit maximum power on maximum number of Tx slots (one CS timeslot and two PS timeslots per frame).



### 3.2 Applied Standard

The Specific Absorption Rate (SAR) testing specification, method, and procedure for this device is in accordance with the following standards:

- FCC 47 CFR Part 2 (2.1093)
- ANSI/IEEE C95.1-1992
- IEEE 1528-2003
- FCC OET Bulletin 65 Supplement C (Edition 01-01)
- FCC KDB 447498 D01 v04
- FCC KDB 648474 D01 v01r05
- FCC KDB 941225 D01 v02
- FCC KDB 941225 D03 v01
- FCC KDB 941225 D04 v01
- FCC KDB 941225 D06 v01
- FCC KDB 248227 D01 v01r02

### 3.3 Device Category and SAR Limits

This device belongs to portable device category because its radiating structure is allowed to be used within 20 centimeters of the body of the user. Limit for General Population/Uncontrolled exposure should be applied for this device, it is 1.6 W/kg as averaged over any 1 gram of tissue.

### 3.4 Test Conditions

#### 3.4.1 Ambient Condition

Ambient Temperature	20 to 24 °C
Humidity	< 60 %

#### 3.4.2 Test Configuration

The device was controlled by using a base station emulator. Communication between the device and the emulator was established by air link. The distance between the EUT and the antenna of the emulator is larger than 50 cm and the output power radiated from the emulator antenna is at least 30 dB smaller than the output power of EUT. The EUT was set from the emulator to radiate maximum output power during all tests.

For WLAN SAR testing, WLAN engineering testing software installed on the EUT can provide continuous transmitting RF signal.



## **4. Specific Absorption Rate (SAR)**

### **4.1 Introduction**

SAR is related to the rate at which energy is absorbed per unit mass in an object exposed to a radio field. The SAR distribution in a biological body is complicated and is usually carried out by experimental techniques or numerical modeling. The standard recommends limits for two tiers of groups, occupational/controlled and general population/uncontrolled, based on a person's awareness and ability to exercise control over his or her exposure. In general, occupational/controlled exposure limits are higher than the limits for general population/uncontrolled.

### **4.2 SAR Definition**

The SAR definition is the time derivative (rate) of the incremental energy (dW) absorbed by (dissipated in) an incremental mass (dm) contained in a volume element (dv) of a given density ( $\rho$ ). The equation description is as below:

$$\text{SAR} = \frac{d}{dt} \left( \frac{dW}{dm} \right) = \frac{d}{dt} \left( \frac{dW}{\rho dv} \right)$$

SAR is expressed in units of Watts per kilogram (W/kg)

SAR measurement can be either related to the temperature elevation in tissue by

$$\text{SAR} = C \left( \frac{\delta T}{\delta t} \right)$$

Where: C is the specific heat capacity,  $\delta T$  is the temperature rise and  $\delta t$  is the exposure duration, or related to the electrical field in the tissue by

$$\text{SAR} = \frac{\sigma |E|^2}{\rho}$$

Where:  $\sigma$  is the conductivity of the tissue,  $\rho$  is the mass density of the tissue and E is the RMS electrical field strength.

However for evaluating SAR of low power transmitter, electrical field measurement is typically applied.

## 5. SAR Measurement System

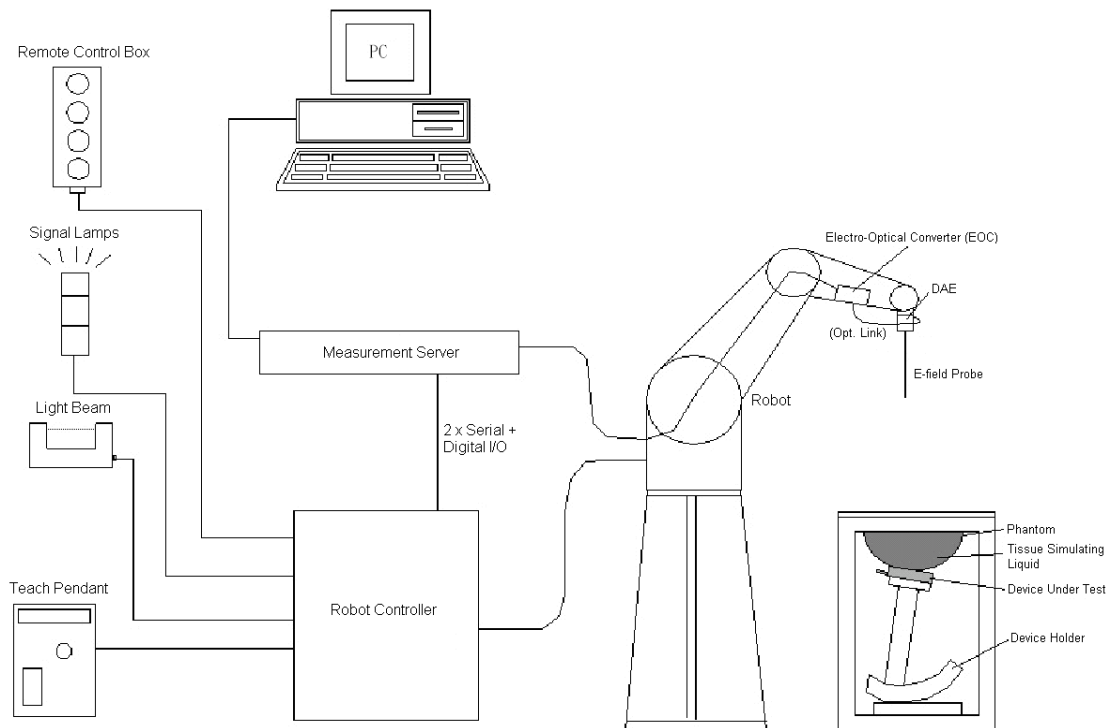

**Fig 5.1 SPEAG DASY System Configurations**

The DASY system for performance compliance tests is illustrated above graphically. This system consists of the following items:

- A standard high precision 6-axis robot with controller, a teach pendant and software
- A data acquisition electronic (DAE) attached to the robot arm extension
- A dosimetric probe equipped with an optical surface detector system
- The electro-optical converter (EOC) performs the conversion between optical and electrical signals
- A measurement server performs the time critical tasks such as signal filtering, control of the robot operation and fast movement interrupts.
- A probe alignment unit which improves the accuracy of the probe positioning
- A computer operating Windows XP
- DASY software
- Remote control with teach pendant and additional circuitry for robot safety such as warning lamps, etc.
- The SAM twin phantom
- A device holder
- Tissue simulating liquid
- Dipole for evaluating the proper functioning of the system

Component details are described in in the following sub-sections.

### 5.1 E-Field Probe

The SAR measurement is conducted with the dosimetric probe (manufactured by SPEAG). The probe is specially designed and calibrated for use in liquid with high permittivity. The dosimetric probe has special calibration in liquid at different frequency. This probe has a built in optical surface detection system to prevent from collision with phantom.

#### 5.1.1 E-Field Probe Specification

##### <ET3DV6 / ET3DV6R Probe >

<b>Construction</b>	Symmetrical design with triangular core Built-in optical fiber for surface detection system. Built-in shielding against static charges. PEEK enclosure material (resistant to organic solvents, e.g., DGBE)	 <p><b>Fig 5.2 Photo of ET3DV6/ET3DV6</b></p>
<b>Frequency</b>	10 MHz to 3 GHz; Linearity: $\pm 0.2$ dB	
<b>Directivity</b>	$\pm 0.2$ dB in HSL (rotation around probe axis) $\pm 0.4$ dB in HSL (rotation normal to probe axis)	
<b>Dynamic Range</b>	5 $\mu$ W/g to 100 mW/g; Linearity: $\pm 0.2$ dB	
<b>Dimensions</b>	Overall length: 330 mm (Tip: 16 mm) Tip diameter: 6.8 mm (Body: 12 mm) Distance from probe tip to dipole centers: 2.7 mm	

##### <EX3DV4 / ES3DV4 Probe >

<b>Construction</b>	Symmetrical design with triangular core Built-in shielding against static charges PEEK enclosure material (resistant to organic solvents, e.g., DGBE)	 <p><b>Fig 5.3 Photo of EX3DV4/ES3DV4</b></p>
<b>Frequency</b>	10 MHz to 6 GHz; Linearity: $\pm 0.2$ dB	
<b>Directivity</b>	$\pm 0.3$ dB in HSL (rotation around probe axis) $\pm 0.5$ dB in tissue material (rotation normal to probe axis)	
<b>Dynamic Range</b>	10 $\mu$ W/g to 100 mW/g; Linearity: $\pm 0.2$ dB (noise: typically < 1 $\mu$ W/g)	
<b>Dimensions</b>	Overall length: 330 mm (Tip: 20 mm) Tip diameter: 2.5 mm (Body: 12 mm) Typical distance from probe tip to dipole centers: 1 mm	

#### 5.1.2 E-Field Probe Calibration

Each probe needs to be calibrated according to a dosimetric assessment procedure with accuracy better than  $\pm 10\%$ . The spherical isotropy shall be evaluated and within  $\pm 0.25$  dB. The sensitivity parameters (NormX, NormY, and NormZ), the diode compression parameter (DCP) and the conversion factor (ConvF) of the probe are tested. The calibration data can be referred to appendix C of this report.

### 5.2 Data Acquisition Electronics (DAE)

The data acquisition electronics (DAE) consists of a highly sensitive electrometer-grade preamplifier with auto-zeroing, a channel and gain-switching multiplexer, a fast 16 bit AD-converter and a command decoder and control logic unit. Transmission to the measurement server is accomplished through an optical downlink for data and status information as well as an optical uplink for commands and the clock. The input impedance of the DAE is 200 MOhm; the inputs are symmetrical and floating. Common mode rejection is above 80 dB.



Fig 5.4 Photo of DAE

### 5.3 Robot

The SPEAG DASY system uses the high precision robots (DASY4: RX90BL; DASY5: TX90XL) type from Stäubli SA (France). For the 6-axis controller system, the robot controller version (DASY4: CS7MB; DASY5: CS8c) from Stäubli is used. The Stäubli robot series have many features that are important for our application:

- High precision (repeatability  $\pm 0.035$  mm)
- High reliability (industrial design)
- Jerk-free straight movements
- Low ELF interference (the closed metallic construction shields against motor control fields)



Fig 5.5 Photo of DASY4

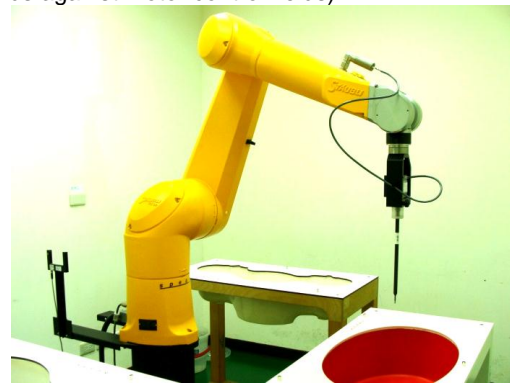

Fig 5.6 Photo of DASY5

### 5.4 Measurement Server

The measurement server is based on a PC/104 CPU board with CPU (DASY4: 166 MHz, Intel Pentium; DASY5: 400 MHz, Intel Celeron), chipdisk (DASY4: 32 MB; DASY5: 128 MB), RAM (DASY4: 64 MB, DASY5: 128 MB). The necessary circuits for communication with the DAE electronic box, as well as the 16 bit AD converter system for optical detection and digital I/O interface are contained on the DASY I/O board, which is directly connected to the PC/104 bus of the CPU board.

The measurement server performs all the real-time data evaluation for field measurements and surface detection, controls robot movements and handles safety operations.



Fig 5.7 Photo of Server for DASY4



Fig 5.8 Photo of Server for DASY5

**5.5 Phantom**

**<SAM Twin Phantom>**

<b>Shell Thickness</b>	2 ± 0.2 mm; Center ear point: 6 ± 0.2 mm	
<b>Filling Volume</b>	Approx. 25 liters	
<b>Dimensions</b>	Length: 1000 mm; Width: 500 mm; Height: adjustable feet	
<b>Measurement Areas</b>	Left Hand, Right Hand, Flat Phantom	

**Fig 5.9 Photo of SAM Phantom**

The bottom plate contains three pair of bolts for locking the device holder. The device holder positions are adjusted to the standard measurement positions in the three sections. A white cover is provided to tap the phantom during off-periods to prevent water evaporation and changes in the liquid parameters. On the phantom top, three reference markers are provided to identify the phantom position with respect to the robot.

**<ELI4 Phantom>**

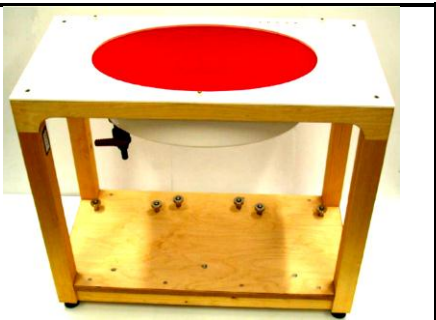
<b>Shell Thickness</b>	2 ± 0.2 mm (sagging: <1%)	
<b>Filling Volume</b>	Approx. 30 liters	
<b>Dimensions</b>	Major ellipse axis: 600 mm Minor axis: 400 mm	

**Fig 5.10 Photo of ELI4 Phantom**

The ELI4 phantom is intended for compliance testing of handheld and body-mounted wireless devices in the frequency range of 30 MHz to 6 GHz. ELI4 is fully compatible with standard and all known tissue simulating liquids.

## 5.6 Device Holder

### <Device Holder for SAM Twin Phantom>

The SAR in the phantom is approximately inversely proportional to the square of the distance between the source and the liquid surface. For a source at 5 mm distance, a positioning uncertainty of  $\pm 0.5$  mm would produce a SAR uncertainty of  $\pm 20$  %. Accurate device positioning is therefore crucial for accurate and repeatable measurements. The positions in which the devices must be measured are defined by the standards.

The DASY device holder is designed to cope with different positions given in the standard. It has two scales for the device rotation (with respect to the body axis) and the device inclination (with respect to the line between the ear reference points). The rotation center for both scales is the ear reference point (ERP). Thus the device needs no repositioning when changing the angles.

The DASY device holder is constructed of low-loss POM material having the following dielectric parameters: relative permittivity  $\epsilon = 3$  and loss tangent  $\delta = 0.02$ . The amount of dielectric material has been reduced in the closest vicinity of the device, since measurements have suggested that the influence of the clamp on the test results could thus be lowered.



Fig 5.11 Device Holder

### <Laptop Extension Kit>

The extension is lightweight and made of POM, acrylic glass and foam. It fits easily on the upper part of the mounting device in place of the phone positioned. The extension is fully compatible with the SAM Twin and ELI phantoms.

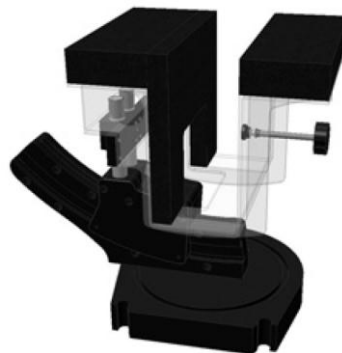

Fig 5.12 Laptop Extension Kit



## 5.7 Data Storage and Evaluation

### 5.7.1 Data Storage

The DASY software stores the assessed data from the data acquisition electronics as raw data (in microvolt readings from the probe sensors), together with all the necessary software parameters for the data evaluation (probe calibration data, liquid parameters and device frequency and modulation data) in measurement files. The post-processing software evaluates the desired unit and format for output each time the data is visualized or exported. This allows verification of the complete software setup even after the measurement and allows correction of erroneous parameter settings. For example, if a measurement has been performed with an incorrect crest factor parameter in the device setup, the parameter can be corrected afterwards and the data can be reevaluated.

The measured data can be visualized or exported in different units or formats, depending on the selected probe type (e.g., [V/m], [A/m], [mW/g]). Some of these units are not available in certain situations or give meaningless results, e.g., a SAR-output in a non-lose media, will always be zero. Raw data can also be exported to perform the evaluation with other software packages.

### 5.7.2 Data Evaluation

The DASY post-processing software (SEMCAD) automatically executes the following procedures to calculate the field units from the microvolt readings at the probe connector. The parameters used in the evaluation are stored in the configuration modules of the software :

<b>Probe parameters :</b>	- Sensitivity	Norm <sub>i</sub> , a <sub>i0</sub> , a <sub>i1</sub> , a <sub>i2</sub>
	- Conversion factor	ConvF <sub>i</sub>
	- Diode compression point	dcp <sub>i</sub>
<b>Device parameters :</b>	- Frequency	f
	- Crest factor	cf
<b>Media parameters :</b>	- Conductivity	σ
	- Density	ρ

These parameters must be set correctly in the software. They can be found in the component documents or they can be imported into the software from the configuration files issued for the DASY components. In the direct measuring mode of the multi-meter option, the parameters of the actual system setup are used. In the scan visualization and export modes, the parameters stored in the corresponding document files are used.

The first step of the evaluation is a linearization of the filtered input signal to account for the compression characteristics of the detector diode. The compensation depends on the input signal, the diode type and the DC-transmission factor from the diode to the evaluation electronics. If the exciting field is pulsed, the crest factor of the signal must be known to correctly compensate for peak power.



The formula for each channel can be given as :

$$V_i = U_i + U_i^2 \cdot \frac{cf}{dcp_i}$$

- with  $V_i$  = compensated signal of channel i, (i = x, y, z)
- $U_i$  = input signal of channel i, (i = x, y, z)
- cf = crest factor of exciting field (DASY parameter)
- dcp<sub>i</sub> = diode compression point (DASY parameter)

From the compensated input signals, the primary field data for each channel can be evaluated :

$$\text{E-field Probes : } E_i = \sqrt{\frac{V_i}{\text{Norm}_i \cdot \text{ConvF}}}$$

$$\text{H-field Probes : } H_i = \sqrt{V_i \cdot \frac{a_{i0} + a_{i1}f + a_{i2}f^2}{f}}$$

- with  $V_i$  = compensated signal of channel i, (i = x, y, z)
- Norm<sub>i</sub> = sensor sensitivity of channel i, (i = x, y, z),  $\mu\text{V}/(\text{V/m})^2$  for E-field Probes
- ConvF = sensitivity enhancement in solution
- $a_{ij}$  = sensor sensitivity factors for H-field probes
- f = carrier frequency [GHz]
- $E_i$  = electric field strength of channel i in V/m
- $H_i$  = magnetic field strength of channel i in A/m

The RSS value of the field components gives the total field strength (Hermitian magnitude) :

$$E_{\text{tot}} = \sqrt{E_x^2 + E_y^2 + E_z^2}$$

The primary field data are used to calculate the derived field units.

$$\text{SAR} = E_{\text{tot}}^2 \cdot \frac{\sigma}{\rho \cdot 1000}$$

- with SAR = local specific absorption rate in mW/g
- $E_{\text{tot}}$  = total field strength in V/m
- $\sigma$  = conductivity in [mho/m] or [Siemens/m]
- $\rho$  = equivalent tissue density in  $\text{g}/\text{cm}^3$

Note that the density is set to 1, to account for actual head tissue density rather than the density of the tissue simulating liquid.





**5.8 Test Equipment List**

Manufacturer	Name of Equipment	Type/Model	Serial Number	Calibration	
				Last Cal.	Due Date
SPEAG	835MHz System Validation Kit	D835V2	499	Mar. 22, 2010	Mar. 21, 2013
SPEAG	1900MHz System Validation Kit	D1900V2	5d041	Mar. 23, 2010	Mar. 22, 2013
SPEAG	2450MHz System Validation Kit	D2450V2	736	Jul. 25, 2011	Jul. 24, 2013
SPEAG	5GHz System Validation Kit	D5GHzV2	1006	Jan. 18, 2012	Jan. 17, 2013
SPEAG	Data Acquisition Electronics	DAE3	577	Jun. 06, 2012	Jun. 05, 2013
SPEAG	Data Acquisition Electronics	DAE3	495	Apr. 23, 2012	Apr. 22, 2013
SPEAG	Data Acquisition Electronics	DAE4	1279	May 03, 2012	May 02, 2013
SPEAG	Data Acquisition Electronics	DAE4	1338	Jun. 12, 2012	Jun. 11, 2013
SPEAG	Dosimetric E-Field Probe	ET3DV6	1787	May 29, 2012	May 28, 2013
SPEAG	Dosimetric E-Field Probe	ET3DV6R	1788	Jan. 26, 2012	Jan. 25, 2013
SPEAG	Dosimetric E-Field Probe	EX3DV4	3792	Jun. 21, 2012	Jun. 20, 2013
SPEAG	Dosimetric E-Field Probe	EX3DV4	3819	Nov. 16, 2011	Nov. 15, 2012
SPEAG	Device Holder	N/A	N/A	NCR	NCR
SPEAG	SAM Phantom	QD 000 P40 C	TP-1303	NCR	NCR
SPEAG	SAM Phantom	QD 000 P40 C	TP-1383	NCR	NCR
SPEAG	SAM Phantom	QD 000 P40 C	TP-1446	NCR	NCR
SPEAG	SAM Phantom	QD 000 P40 C	TP-1478	NCR	NCR
SPEAG	SAM Phantom	QD 000 P41 C	TP-1150	NCR	NCR
SPEAG	SAM Phantom	QD 000 P40 CD	TP-1644	NCR	NCR
SPEAG	SAM Phantom	SM 000 T01 DA	TP-1542	NCR	NCR
SPEAG	ELI4 Phantom	QD 0VA 001 BB	1026	NCR	NCR
SPEAG	ELI4 Phantom	QD 0VA 001 BA	1029	NCR	NCR
SPEAG	ELI4 Phantom	QD 0VA 002 AA	TP-1127	NCR	NCR
SPEAG	ELI4 Phantom	QD 0VA 002 AA	TP-1131	NCR	NCR
Agilent	Network Analyzer	E5071C	MY46101588	May 11, 2012	May 10, 2013
Agilent	ESG Vector Series Signal Generator	E4438C	MY49070755	Oct. 17, 2011	Oct. 16, 2012
Anritsu	Power Meter	ML2495A	0932001	Sep. 21, 2011	Sep. 20, 2012
Anritsu	Radio Communication Analyzer	MT8820C	6201074414	Dec. 21, 2011	Dec. 20, 2012
Agilent	Wireless Communication Test Set	E5515C	MY48360820	Jan. 05, 2012	Jan. 04, 2014
Agilent	Wireless Communication Test Set	E5515C	GB46311322	Mar. 23, 2011	Mar. 22, 2013
Agilent	Wireless Communication Test Set	E5515C	MY50264370	Apr. 19, 2011	Apr. 18, 2013
Agilent	Wireless Communication Test Set	E5515C	MY50266977	Nov. 13, 2011	Nov. 12, 2013
R&S	Universal Digital Radiocommunication Tester	CMU200	106656	Jun. 28, 2012	Jun. 27, 2013
R&S	Spectrum Analyzer	FSP	101131	Jul. 23, 2012	Jul. 22, 2013

**Table 5.1 Test Equipment List**

**Note:**

1. The calibration certificate of DASY can be referred to appendix C of this report.
2. Referring to KDB 450824 D02, the dipole calibration interval can be extended to 3 years with justification. The dipoles are also not physically damaged, or repaired during the interval.
3. The justification data of dipole D835V2, SN: 499, D1900V2, SN: 5d041, and D2450V2, SN: 736 can be found in appendix C. The return loss is < -20dB, within 20% of prior calibration, the impedance is within 5 ohm of prior calibration.

## 6. Tissue Simulating Liquids

For the measurement of the field distribution inside the SAM phantom with DASY, the phantom must be filled with around 25 liters of homogeneous body tissue simulating liquid. For head SAR testing, the liquid height from the ear reference point (ERP) of the phantom to the liquid top surface is larger than 15 cm, which is shown in Fig. 6.1. For body SAR testing, the liquid height from the center of the flat phantom to the liquid top surface is larger than 15 cm, which is shown in Fig. 6.2.

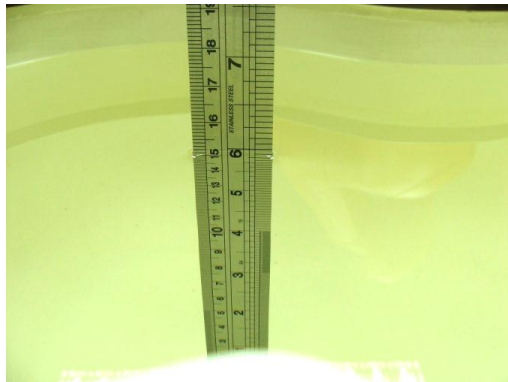

Fig 6.1 Photo of Liquid Height for Head SAR



Fig 6.2 Photo of Liquid Height for Body SAR

The following table gives the recipes for tissue simulating liquid.

Frequency (MHz)	Water (%)	Sugar (%)	Cellulose (%)	Salt (%)	Preventol (%)	DGBE (%)	Conductivity ( $\sigma$ )	Permittivity ( $\epsilon_r$ )
<b>For Head</b>								
835	40.3	57.9	0.2	1.4	0.2	0	0.90	41.5
1800, 1900, 2000	55.2	0	0	0.3	0	44.5	1.40	40.0
2450	55.0	0	0	0	0	45.0	1.80	39.2
<b>For Body</b>								
835	50.8	48.2	0	0.9	0.1	0	0.97	55.2
1800, 1900, 2000	70.2	0	0	0.4	0	29.4	1.52	53.3
2450	68.6	0	0	0	0	31.4	1.95	52.7

Table 6.1 Recipes of Tissue Simulating Liquid

### Simulating Liquid for 5G, Manufactured by SP EAG

Ingredients	(% by weight)
Water	64~78%
Mineral oil	11~18%
Emulsifiers	9~15%
Additives and Salt	2~3%



The dielectric parameters of the liquids were verified prior to the SAR evaluation using an Agilent 85070D Dielectric Probe Kit and an Agilent Network Analyzer.

The following table shows the measuring results for simulating liquid.

Freq. (MHz)	Liquid Type	Temp. (°C)	Conductivity ( $\sigma$ )	Permittivity ( $\epsilon_r$ )	Conductivity Target ( $\sigma$ )	Permittivity Target ( $\epsilon_r$ )	Delta ( $\sigma$ ) (%)	Delta ( $\epsilon_r$ ) (%)	Limit (%)	Date
835	Head	21.3	0.921	41.254	0.9	41.5	2.33	-0.59	±5	Aug. 19, 2012
835	Head	21.6	0.894	41.661	0.9	41.5	-0.67	0.39	±5	Aug. 24, 2012
835	Body	21.5	0.964	54.532	0.97	55.2	-0.62	-1.21	±5	Aug. 19, 2012
835	Body	21.5	0.985	54.5	0.97	55.2	1.55	-1.27	±5	Aug. 20, 2012
835	Body	21.6	0.996	55.38	0.97	55.2	2.68	0.33	±5	Aug. 25, 2012
835	Body	21.5	0.963	54.5	0.97	55.2	-0.72	-1.27	±5	Sep. 05, 2012
1900	Head	21.4	1.427	39.815	1.4	40	1.93	-0.46	±5	Aug. 19, 2012
1900	Head	21.6	1.435	38.114	1.4	40	2.50	-4.72	±5	Aug. 24, 2012
1900	Body	21.5	1.559	51.962	1.52	53.3	2.57	-2.51	±5	Aug. 19, 2012
1900	Body	21.5	1.53	52.5	1.52	53.3	0.66	-1.50	±5	Aug. 20, 2012
1900	Body	21.6	1.501	54.839	1.52	53.3	-1.25	2.89	±5	Aug. 25, 2012
1900	Body	21.5	1.52	53.2	1.52	53.3	0.00	-0.19	±5	Sep. 05, 2012
2450	Head	21.4	1.86	39.2	1.8	39.2	3.33	0.00	±5	Sep. 03, 2012
2450	Head	21.5	1.84	39.3	1.8	39.2	2.22	0.26	±5	Sep. 05, 2012
2450	Body	21.5	2.02	53.9	1.95	52.7	3.59	2.28	±5	Sep. 03, 2012
2450	Body	21.5	1.93	53.6	1.95	52.7	-1.03	1.71	±5	Sep. 05, 2012
5200	Head	21.3	4.8	35.5	4.66	36.0	3.00	-1.39	±5	Aug. 27, 2012
5200	Body	21.5	5.284	47.499	5.3	49	-0.30	-3.06	±5	Aug. 26, 2012
5200	Body	21.5	5.14	47.5	5.3	49	-3.02	-3.06	±5	Aug. 29, 2012
5200	Body	21.5	5.11	47.4	5.3	49	-3.58	-3.27	±5	Sep. 05, 2012
5500	Head	21.3	5.12	35	4.96	35.6	3.23	-1.69	±5	Aug. 27, 2012
5500	Body	21.5	5.677	46.97	5.65	48.6	0.48	-3.35	±5	Aug. 26, 2012
5500	Body	21.5	5.52	47	5.65	48.6	-2.30	-3.29	±5	Aug. 29, 2012
5500	Body	21.5	5.49	47	5.65	48.6	-2.83	-3.29	±5	Sep. 05, 2012
5800	Head	21.3	5.4	34.4	5.27	35.3	2.47	-2.55	±5	Aug. 27, 2012
5800	Body	21.5	5.99	46.5	6	48.2	-0.17	-3.53	±5	Aug. 29, 2012
5800	Body	21.5	5.96	46.5	6	48.2	-0.67	-3.53	±5	Sep. 05, 2012

**Table 6.2 Measuring Results for Simulating Liquid**

## 7. SAR Measurement Evaluation

Each DASY system is equipped with one or more system validation kits. These units, together with the predefined measurement procedures within the DASY software, enable the user to conduct the system performance check and system validation. System validation kit includes a dipole, tripod holder to fix it underneath the flat phantom and a corresponding distance holder.

### 7.1 Purpose of System Performance check

The system performance check verifies that the system operates within its specifications. System and operator errors can be detected and corrected. It is recommended that the system performance check be performed prior to any usage of the system in order to guarantee reproducible results. The system performance check uses normal SAR measurements in a simplified setup with a well characterized source. This setup was selected to give a high sensitivity to all parameters that might fail or vary over time. The system check does not intend to replace the calibration of the components, but indicates situations where the system uncertainty is exceeded due to drift or failure.

### 7.2 System Setup

In the simplified setup for system evaluation, the EUT is replaced by a calibrated dipole and the power source is replaced by a continuous wave that comes from a signal generator. The calibrated dipole must be placed beneath the flat phantom section of the SAM twin phantom with the correct distance holder. The distance holder should touch the phantom surface with a light pressure at the reference marking and be oriented parallel to the long side of the phantom. The equipment setup is shown below:

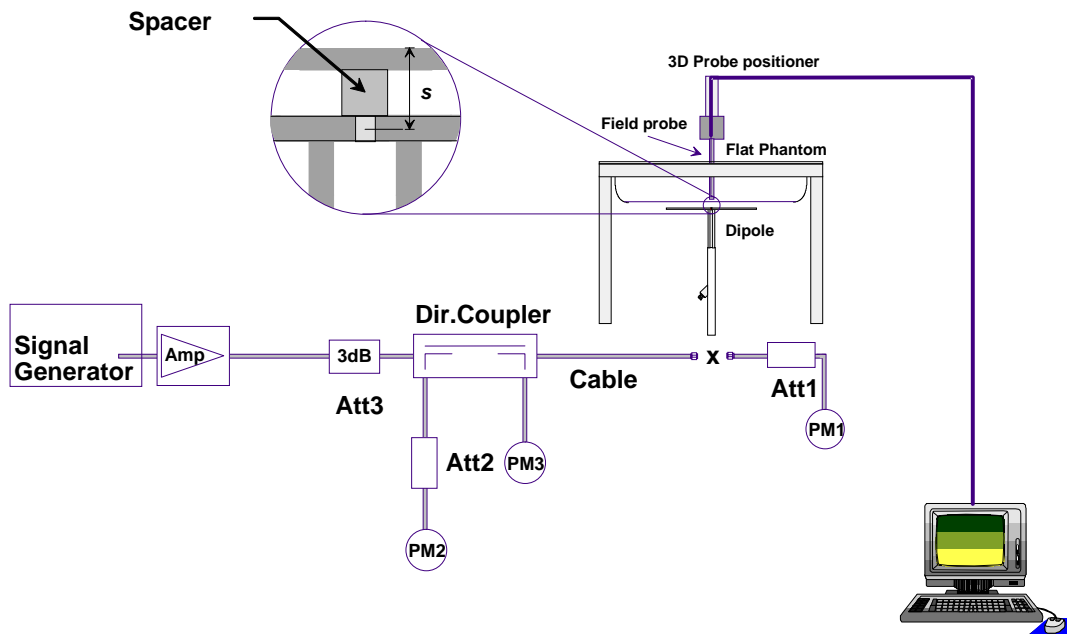
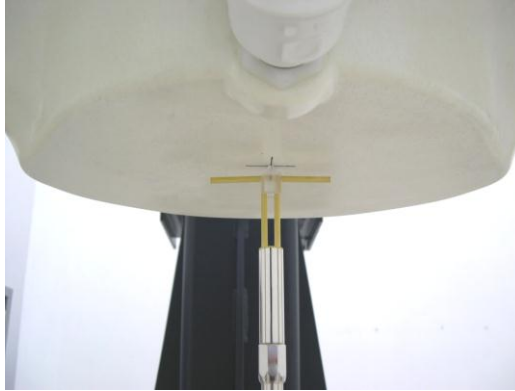

Fig 7.1 System Setup for System Evaluation

1. Signal Generator
2. Amplifier
3. Directional Coupler
4. Power Meter
5. Calibrated Dipole

The output power on dipole port must be calibrated to 24 dBm (250 mW) before dipole is connected.



**Fig 7.2 Photo of Dipole Setup**



7.3 Validation Results

Comparing to the original SAR value provided by SPEAG, the validation data should be within its specification of 10 %. Table 7.1 shows the target SAR and measured SAR after normalized to 1W input power. The table below indicates the system performance check can meet the variation criterion and the plots can be referred to Appendix A of this report.

Table with 7 columns: Measurement Date, Frequency (MHz), Liquid Type, Targeted SAR1g (W/kg), Measured SAR1g (W/kg), Normalized SAR1g (W/kg), Deviation (%). Rows include various dates and frequencies (835, 1900, 2450, 5200, 5500, 5800 MHz) for Head and Body measurements.

Table 7.1 Target and Measurement SAR after Normalized

## 8. EUT Testing Position

This EUT was tested in ten different positions. They are right cheek, right tilted, left cheek, left tilted, Front of the EUT with phantom 1 cm gap, Back of the EUT with phantom 1 cm gap, Top Side of the EUT with phantom 1 cm gap, Bottom Side of the EUT with phantom 1 cm gap, Right Side of the EUT with phantom 1 cm gap, and Left Side of the EUT with phantom 1 cm gap, as illustrated below:

### 8.1 Define two imaginary lines on the handset

- The vertical centerline passes through two points on the front side of the handset - the midpoint of the width  $w_t$  of the handset at the level of the acoustic output, and the midpoint of the width  $w_b$  of the bottom of the handset.
- The horizontal line is perpendicular to the vertical centerline and passes through the center of the acoustic output. The horizontal line is also tangential to the face of the handset at point A.
- The two lines intersect at point A. Note that for many handsets, point A coincides with the center of the acoustic output; however, the acoustic output may be located elsewhere on the horizontal line. Also note that the vertical centerline is not necessarily parallel to the front face of the handset, especially for clamshell handsets, handsets with flip covers, and other irregularly shaped handsets.

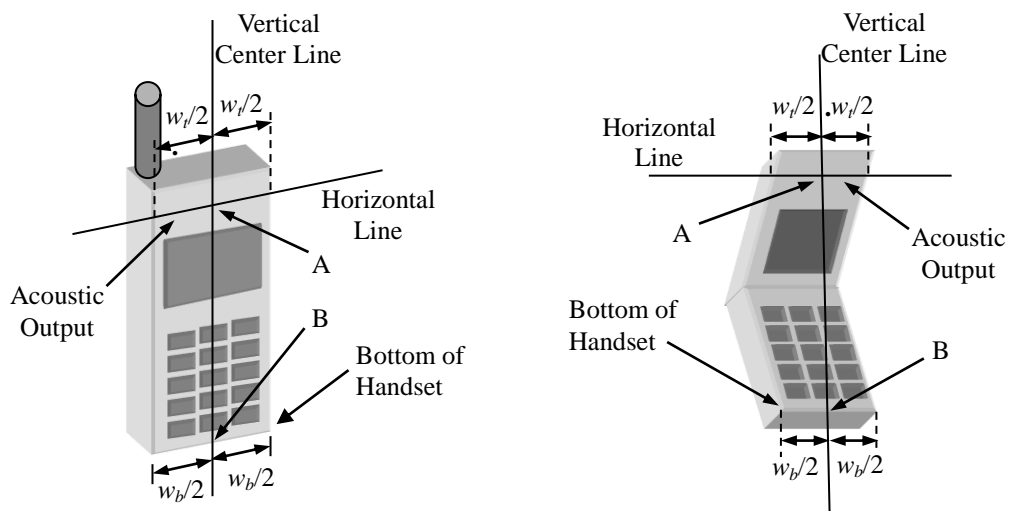

Fig 8.1 Illustration for Handset Vertical and Horizontal Reference Lines

**8.2 Cheek Position**

- (a) To position the device with the vertical center line of the body of the device and the horizontal line crossing the center piece in a plane parallel to the sagittal plane of the phantom. While maintaining the device in this plane, align the vertical center line with the reference plane containing the three ear and mouth reference point (M: Mouth, RE: Right Ear, and LE: Left Ear) and align the center of the ear piece with the line RE-LE.
- (b) To move the device towards the phantom with the ear piece aligned with the line LE-RE until the phone touched the ear. While maintaining the device in the reference plane and maintaining the phone contact with the ear, move the bottom of the phone until any point on the front side is in contact with the cheek of the phantom or until contact with the ear is lost (see Fig. 9.2).

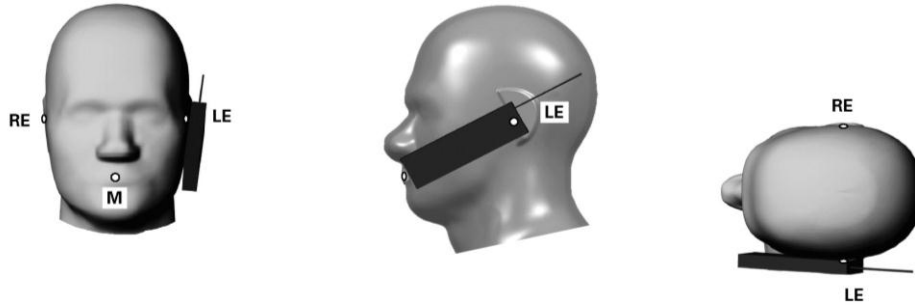

Fig 8.2 Illustration for Cheek Position

**8.3 Tilted Position**

- (a) To position the device in the “cheek” position described above.
- (b) While maintaining the device the reference plane described above and pivoting against the ear, moves it outward away from the mouth by an angle of 15 degrees or until contact with the ear is lost (see Fig. 9.3).

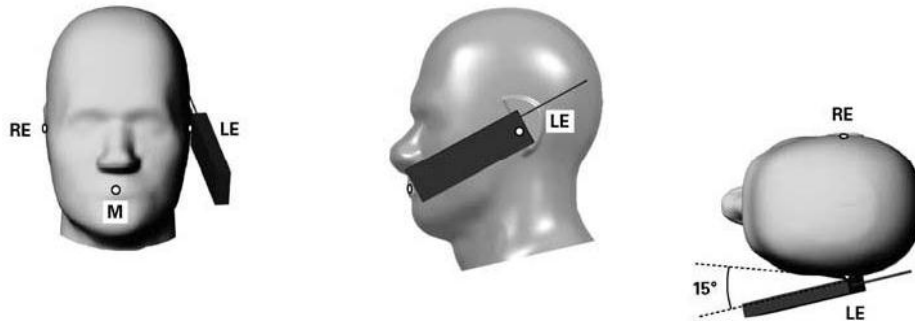
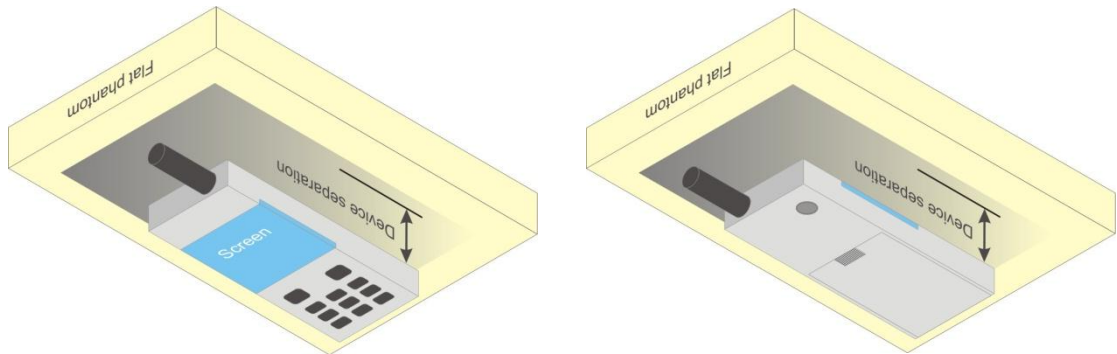

Fig 8.3 Illustration for Tilted Position



### 8.4 Body Worn Position

- (a) To position the device parallel to the phantom surface with either keypad up or down.
- (b) To adjust the device parallel to the flat phantom.
- (c) To adjust the distance between the device surface and the flat phantom to 1 cm.



**Fig 8.4 Illustration for Body Worn Position**

#### <EUT Setup Photos>

Please refer to Appendix D for the test setup photos.

## **9. Measurement Procedures**

The measurement procedures are as follows:

- (a) Use base station simulator (if applicable) or engineering software to transmit RF power continuously (continuous Tx) in the highest power channel.
- (b) Keep EUT to radiate maximum output power or 100% duty factor (if applicable)
- (c) Measure output power through RF cable and power meter.
- (d) Set scan area, grid size and other setting on the DASY software.
- (e) Measure SAR results for the highest power channel on each testing position.
- (f) Find out the largest SAR result on these testing positions of each band
- (g) Measure SAR results for other channels in worst SAR testing position if the SAR of highest power channel is larger than 0.8 W/kg

According to the test standard, the recommended procedure for assessing the peak spatial-average SAR value consists of the following steps:

- (a) Power reference measurement
- (b) Area scan
- (c) Zoom scan
- (d) Power drift measurement

### **9.1 Spatial Peak SAR Evaluation**

The procedure for spatial peak SAR evaluation has been implemented according to the test standard. It can be conducted for 1g and 10g, as well as for user-specific masses. The DASY software includes all numerical procedures necessary to evaluate the spatial peak SAR value.

The base for the evaluation is a "cube" measurement. The measured volume must include the 1g and 10g cubes with the highest averaged SAR values. For that purpose, the center of the measured volume is aligned to the interpolated peak SAR value of a previously performed area scan.

The entire evaluation of the spatial peak values is performed within the post-processing engine (SEMCAD). The system always gives the maximum values for the 1g and 10g cubes. The algorithm to find the cube with highest averaged SAR is divided into the following stages:

- (a) Extraction of the measured data (grid and values) from the Zoom Scan
- (b) Calculation of the SAR value at every measurement point based on all stored data (A/D values and measurement parameters)
- (c) Generation of a high-resolution mesh within the measured volume
- (d) Interpolation of all measured values from the measurement grid to the high-resolution grid
- (e) Extrapolation of the entire 3-D field distribution to the phantom surface over the distance from sensor to surface
- (f) Calculation of the averaged SAR within masses of 1g and 10g

### **9.2 Area & Zoom Scan Procedures**

First Area Scan is used to locate the approximate location(s) of the local peak SAR value(s). The measurement grid within an Area Scan is defined by the grid extent, grid step size and grid offset. Next, in order to determine the EM field distribution in a three-dimensional spatial extension, Zoom Scan is required. The Zoom Scan measures 5x5x7 points with step size 8, 8 and 5 mm for 300 MHz to 3 GHz, and 8x8x8 points with step size 4, 4 and 2.5 mm for 3 GHz to 6 GHz. The Zoom Scan is performed around the highest E-field value to determine the averaged SAR-distribution over 10 g.



### **9.3 Volume Scan Procedures**

The volume scan is used to assess overlapping SAR distributions for antennas transmitting in different frequency bands. It is equivalent to an oversized zoom scan used in standalone measurements. The measurement volume will be used to enclose all the simultaneous transmitting antennas. For antennas transmitting simultaneously in different frequency bands, the volume scan is measured separately in each frequency band. In order to sum correctly to compute the 1g aggregate SAR, the EUT remains in the same test position for all measurements and all volume scans use the same spatial resolution and grid spacing (step-size is 4, 4 and 2.5 mm). When all volume scans are completed, the software, SEMCAD postprocessor can combine and subsequently superpose these measurement data to calculate the multiband SAR.

### **9.4 SAR Averaged Methods**

In DASy, the interpolation and extrapolation are both based on the modified Quadratic Shepard's method. The interpolation scheme combines a least-square fitted function method and a weighted average method which are the two basic types of computational interpolation and approximation.

Extrapolation routines are used to obtain SAR values between the lowest measurement points and the inner phantom surface. The extrapolation distance is determined by the surface detection distance and the probe sensor offset. The uncertainty increases with the extrapolation distance. To keep the uncertainty within 1% for the 1 g and 10 g cubes, the extrapolation distance should not be larger than 5 mm.

### **9.5 Power Drift Monitoring**

All SAR testing is under the EUT installed full charged battery and transmit maximum output power. In DASy measurement software, the power reference measurement and power drift measurement procedures are used for monitoring the power drift of EUT during SAR test. Both these procedures measure the field at a specified reference position before and after the SAR testing. The software will calculate the field difference in dB. If the power drift more than 5%, the SAR will be retested.

## 10. SAR Test Configurations

### 10.1 Exposure Positions Consideration

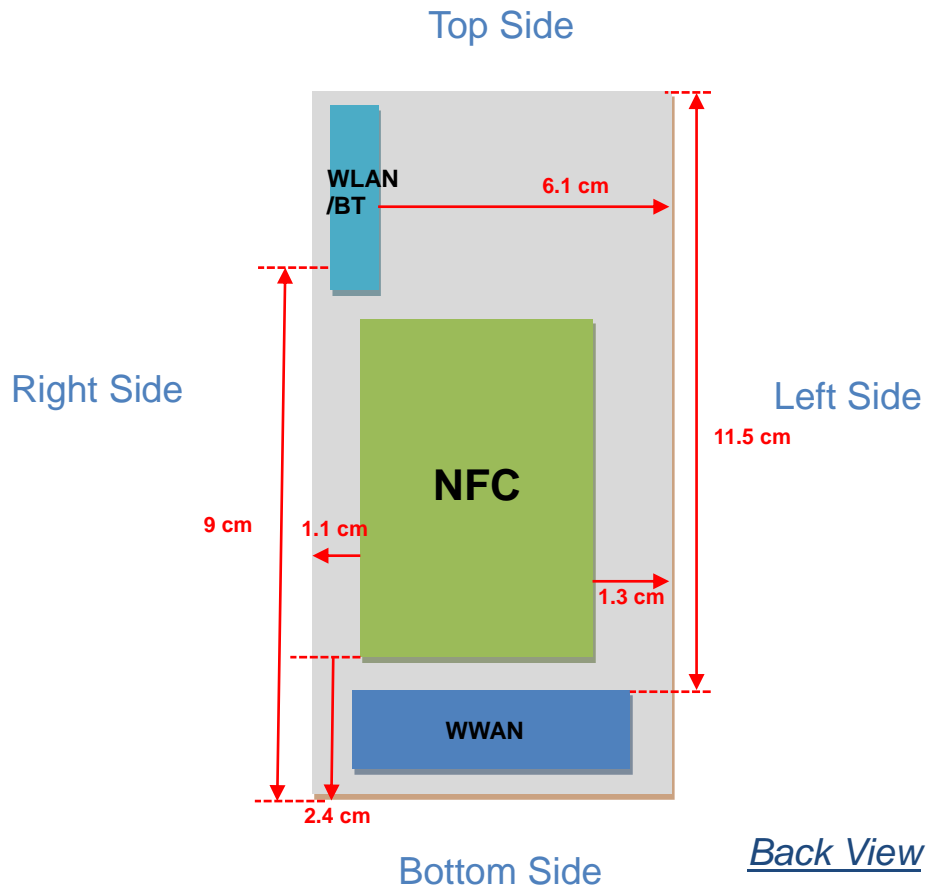

Antennas	Wireless Interface
WWAN Antenna (Tx / Rx)	GSM850 PCS WCDMA Band II WCDMA Band V
BT&WLAN Antenna (Tx / Rx)	WLAN 2.4GHz WLAN 5GHz Bluetooth
NFC Antenna (Tx / Rx)	NFC



Sides for SAR tests; Hotspot mode						
Test distance: 10 mm						
Antennas	Back	Front	Top Side	Bottom Side	Right Side	Left Side
WWAN	YES	YES	NO	YES	YES	YES
BT&WLAN	YES	YES	YES	NO	YES	NO

**Note:**

1. Head/Body-worn/Hotspot mode SAR assessments are required.
2. Referring to KDB 941225 D06, when the overall device length and width are  $\geq 9\text{cm} \times 5\text{cm}$ , the test distance is 10 mm. SAR must be measured for all sides and surfaces with a transmitting antenna located within 25mm from that surface or edge.
3. For WWAN Main antenna, SAR measurements at Top side is not required since the distance between EUT and flat phantom  $> 25\text{mm}$ .
4. For WLAN antenna, SAR measurements Bottom / Left side are not required since the distance between EUT and flat phantom  $> 25\text{mm}$ .
5. Per KDB 648474 D01, Bluetooth output power  $\leq 2 \times P_{\text{Ref}}$  and the distance to WWAN antenna  $\geq 5\text{cm}$ , therefore, stand-alone SAR is not required.



**10.2 Conducted RF Output Power (Unit: dBm)**

**<GSM/GPRS/EDGE>**

Band		Burst Average Power					
		GSM850			GSM1900		
Channel		128	189	251	512	661	810
Frequency (MHz)		824.2	836.4	848.8	1850.2	1880.0	1909.8
GSM (1 Uplink)		32.79	32.78	32.76	30.29	30.29	30.30
GPRS 8 (1 Uplink) – CS1		32.78	32.78	32.78	30.28	30.28	30.29
GPRS 10 (2 Uplink) – CS1		31.53	31.52	31.52	29.03	29.05	29.06
GPRS 11 (3 Uplink) – CS1		30.53	30.53	30.52	28.51	28.53	28.55
GPRS 12 (4 Uplink) – CS1		29.54	29.53	29.52	27.52	27.53	27.55
EDGE 8 (GMSK, 1 Uplink) – MCS1		32.78	32.78	32.77	30.27	30.27	30.23
EDGE 10 (GMSK, 2 Uplink) – MCS1		31.52	31.52	31.52	29.03	29.05	29.06
EDGE 11 (GMSK, 3 Uplink) – MCS1		30.53	30.53	30.52	28.51	28.54	28.55
EDGE 12 (GMSK, 4 Uplink) – MCS1		29.53	29.53	29.52	27.53	27.53	27.54
EDGE 8 (8PSK, 1 Uplink) – MCS9		26.21	26.20	26.19	25.04	25.03	25.05
EDGE 10 (8PSK, 2 Uplink) – MCS9		25.35	25.36	25.34	24.13	24.13	24.15
EDGE 11 (8PSK, 3 Uplink) – MCS9		25.36	25.37	25.34	23.06	23.06	23.09
EDGE 12 (8PSK, 4 Uplink) – MCS9		23.56	23.53	23.51	22.06	22.05	22.07
DTM 5	GSM, 1 Uplink	31.53	31.52	31.52	29.04	29.05	29.06
	GPRS, 1 Uplink – CS1	31.48	31.47	31.47	29.02	29.03	29.05
DTM 9	GSM, 1 Uplink	31.52	31.51	31.50	29.03	29.04	29.05
	GPRS, 1 Uplink – CS1	31.47	31.45	31.46	29.00	29.01	29.04
DTM 11	GSM, 1 Uplink	30.55	30.54	30.53	28.51	28.53	28.55
	GPRS, 2 Uplink – CS1	30.47	30.47	30.47	28.49	28.51	28.53
DTM 5	GSM, 1 Uplink	31.48	31.47	31.47	28.98	28.99	29.01
	EDGE 8PSK, 1 Uplink – MCS9	25.26	25.26	25.24	24.02	24.02	24.03
DTM 9	GSM, 1 Uplink	31.47	31.46	31.45	28.97	28.98	29.00
	EDGE 8PSK, 1 Uplink – MCS9	25.25	25.24	25.22	24.00	24.01	24.02
DTM 11	GSM, 1 Uplink	30.48	30.48	30.47	28.45	28.47	28.49
	EDGE 8PSK, 2 Uplink – MCS9	25.26	25.26	25.23	22.95	22.95	22.97



Source-Based Time-Averaged Power						
Band	GSM850			GSM1900		
Channel	128	189	251	512	661	810
Frequency (MHz)	824.2	836.4	848.8	1850.2	1880.0	1909.8
GSM (1 Uplink)	23.79	23.78	23.76	21.29	21.29	21.30
GPRS 8 (1 Uplink) – CS1	23.78	23.78	23.78	21.28	21.28	21.29
GPRS 10 (2 Uplink) – CS1	25.53	25.52	25.52	23.03	23.05	23.06
GPRS 11 (3 Uplink) – CS1	26.27	26.27	26.26	24.25	24.27	24.29
GPRS 12 (4 Uplink) – CS1	26.54	26.53	26.52	24.52	24.53	24.55
EDGE 8 (GMSK, 1 Uplink) – MCS1	23.78	23.78	23.77	21.27	21.27	21.23
EDGE 10 (GMSK, 2 Uplink) – MCS1	25.52	25.52	25.52	23.03	23.05	23.06
EDGE 11 (GMSK, 3 Uplink) – MCS1	26.27	26.27	26.26	24.25	24.28	24.29
EDGE 12 (GMSK, 4 Uplink) – MCS1	26.53	26.53	26.52	24.53	24.53	24.54
EDGE 8 (8PSK, 1 Uplink) – MCS9	17.21	17.20	17.19	16.04	16.03	16.05
EDGE 10 (8PSK, 2 Uplink) – MCS9	19.35	19.36	19.34	18.13	18.13	18.15
EDGE 11 (8PSK, 3 Uplink) – MCS9	21.10	21.11	21.08	18.80	18.80	18.83
EDGE 12 (8PSK, 4 Uplink) – MCS9	20.56	20.53	20.51	19.06	19.05	19.07
DTM 5	GSM, 1 Uplink	25.48	25.47	25.47	23.01	23.02
	GPRS, 1 Uplink – CS1					
DTM 9	GSM, 1 Uplink	25.47	25.46	25.46	22.99	23.00
	GPRS, 1 Uplink – CS1					
DTM 11	GSM, 1 Uplink	26.24	26.23	26.23	24.24	24.26
	GPRS, 2 Uplink – CS1					
DTM 5	GSM, 1 Uplink	23.38	23.37	23.37	21.15	21.16
	EDGE 8PSK, 1 Uplink – MCS9					
DTM 9	GSM, 1 Uplink	23.37	23.36	23.35	21.14	21.15
	EDGE 8PSK, 1 Uplink – MCS9					
DTM 11	GSM, 1 Uplink	23.49	23.49	23.48	21.36	21.37
	EDGE 8PSK, 2 Uplink – MCS9					

**Remark:** The source-based time-averaged power is linearly scaled the maximum burst averaged power based on time slots. The calculated method are shown as below:  
Source based time averaged power = Maximum burst averaged power (1 Uplink) - 9 dB  
Source based time averaged power = Maximum burst averaged power (2 Uplink) - 6 dB  
Source based time averaged power = Maximum burst averaged power (3 Uplink) - 4.26 dB  
Source based time averaged power = Maximum burst averaged power (4 Uplink) - 3 dB

**Note:**

- For Head SAR testing, GSM, GPRS, EDGE and DTM should be evaluated, therefore the EUT was set in GPRS 12 for GSM850 and set in GPRS 12 for GSM1900 due to its highest source-based time-average power.
- For Body SAR testing, GSM, GPRS, EDGE and DTM should be evaluated, therefore the EUT was set in GPRS 12 for GSM850 and set in GPRS 12 for GSM1900 due to its highest source-based time-average power.
- Per KDB 447498, the maximum output power channel is used for SAR testing and for further SAR test reduction.
- EDGE tests with MCS1 setting, GMSK modulation. Burst average power with MCS9 setting 8 PSK modulation, is provided voluntary for reference.



<WCDMA>

Band	WCDMA Band V			WCDMA Band II		
Channel	4132	4182	4233	9262	9400	9538
Frequency (MHz)	826.4	836.4	846.6	1852.4	1880.0	1907.6
AMR	23.56	23.42	23.44	23.44	23.33	23.28
RMC 12.2K	23.58	23.44	23.46	23.46	23.35	23.30
HSDPA Subtest-1	23.37	23.20	23.21	23.26	23.11	23.09
HSDPA Subtest-2	22.35	22.16	22.18	22.22	22.11	22.06
HSDPA Subtest-3	22.10	21.90	21.94	21.97	21.90	21.87
HSDPA Subtest-4	21.87	21.70	21.71	21.71	21.65	21.56
HSUPA Subtest-1	22.40	22.16	22.25	22.36	22.28	22.27
HSUPA Subtest-2	20.86	20.67	20.78	20.77	20.68	20.61
HSUPA Subtest-3	21.13	20.96	21.00	21.15	21.06	21.05
HSUPA Subtest-4	20.79	20.68	20.71	20.69	20.62	20.59
HSUPA Subtest-5	22.47	22.34	22.36	22.45	22.40	22.39

MPR (dB)							
3GPP MPR	Subtest	WCDMA Band V			WCDMA Band II		
0	HSDPA Subtest-1	0.00	0.00	0.00	0.00	0.00	0.00
0	HSDPA Subtest-2	1.02	1.04	1.03	1.04	1.00	1.03
≤ 0.5	HSDPA Subtest-3	1.27	1.30	1.27	1.29	1.21	1.22
≤ 0.5	HSDPA Subtest-4	1.50	1.50	1.50	1.55	1.46	1.53
0	HSUPA Subtest-1	0.07	0.18	0.11	0.09	0.12	0.12
≤ 2	HSUPA Subtest-2	1.61	1.67	1.58	1.68	1.72	1.78
≤ 1	HSUPA Subtest-3	1.34	1.38	1.36	1.30	1.34	1.34
≤ 2	HSUPA Subtest-4	1.68	1.66	1.65	1.76	1.78	1.80
0	HSUPA Subtest-5	0.00	0.00	0.00	0.00	0.00	0.00

Note:

- For Head SAR, per KDB 941225 D01, RMC 12.2kbps setting is used to evaluate SAR. If AMR 12.2kbps power is < 1/4 dB higher than RMC, SAR tests with AMR 12.2kbps can be excluded.
- For Body SAR, per KDB 941225 D01, RMC 12.2kbps setting is used to evaluate SAR. If HSDPA subset-1 and HSUPA subset-5 output power is < 1/4 dB higher than RMC, and SAR with RMC 12.2kbps setting is ≤ 1.2W/kg, HSDPA and HSUPA SAR evaluation can be excluded.
- EUT is designed to follow the MPR of 3GPP Table 5.2B.1 specification. In production units, MPR result deviation from 3GPP is expected; the implementation and expected deviation is detailed in tune-up procedure exhibit.



<WLAN 2.4GHz>

WLAN 2.4G 802.11b Average Power (dBm)						
Power vs. Channel			Power vs. Data Rate			
Channel	Frequency (MHz)	Data Rate (bps)	Channel	Data Rate (bps)		
		1M		2M	5.5M	11M
CH 01	2412	18.29	CH 01	18.23	18.17	18.24
CH 06	2437	18.21				
CH 11	2462	18.14				

WLAN 2.4G 802.11g Average Power (dBm)										
Power vs. Channel			Power vs. Data Rate							
Channel	Frequency (MHz)	Data Rate (bps)	Channel	Data Rate (bps)						
		6M		9M	12M	18M	24M	36M	48M	54M
CH 01	2412	16.72	CH 01	16.64	16.61	16.62	16.62	16.69	16.69	13.84
CH 06	2437	16.48								
CH 11	2462	14.47								

WLAN 2.4G 802.11n (BW 20MHz) Average Power (dBm)										
Power vs. Channel			Power vs. Data Rate							
Channel	Frequency (MHz)	MCS Index	Channel	MCS Index						
		MCS0		MCS1	MCS2	MCS3	MCS4	MCS5	MCS6	MCS7
CH 01	2412	17.39	CH 06	17.41	17.39	17.35	17.31	14.34	14.29	13.26
CH 06	2437	17.43								
CH 11	2462	13.57								

WLAN 2.4G 802.11n (BW 40MHz) Average Power (dBm)										
Power vs. Channel			Power vs. Data Rate							
Channel	Frequency (MHz)	MCS Index	Channel	MCS Index						
		MCS0		MCS1	MCS2	MCS3	MCS4	MCS5	MCS6	MCS7
CH 03	2422	14.51	CH 06	15.55	15.54	15.52	15.55	15.56	15.54	15.53
CH 06	2437	15.57								
CH 09	2452	13.46								

Note:

1. Per KDB 248227, choose the highest output power channel to test SAR and determine further SAR exclusion
2. Per KDB 248227, 11g and 11n output power is less than 1/4 dB higher than 11b mode, thus the SAR can be excluded.
3. For each frequency band, testing at higher data rates and higher order modulations is not required when the maximum average output power for each of these configurations is less than 1/4 dB higher than those measured at the lowest data rate.

<Bluetooth>

Band	Bluetooth		
Channel	0	39	78
Frequency (MHz)	2402	2441	2480
Average Power (dBm)	6.16	7.00	7.61

Note: Per KDB 447498, 2.4GHz Bluetooth SAR is excluded due to highest output power  $\leq 60/f$  (GHz) mW, where  $60/f$  (GHz) = 24mW = 13.8dBm.



<WLAN 5GHz>

WLAN 5G 802.11a Average Power (dBm)										
Power vs. Channel			Power vs. Data Rate							
Channel	Frequency (MHz)	Data Rate (bps)	Channel	Data Rate (bps)						
		6M		9M	12M	18M	24M	36M	48M	54M
CH 36	5180	14.51	CH 48	14.78	14.78	14.76	14.77	14.77	14.75	11.60
CH 40	5200	14.66								
CH 44	5220	14.70								
CH 48	5240	<b>14.86</b>								
CH 52	5260	14.76	CH 60	15.09	15.17	15.14	15.07	15.15	15.06	11.62
CH 56	5280	14.89								
CH 60	5300	<b>15.18</b>								
CH 64	5320	14.82								
CH 100	5500	<b>15.67</b>	CH 100	15.61	15.41	15.52	15.56	15.48	15.43	12.26
CH 104	5520	15.21								
CH 108	5540	15.33								
CH 112	5560	15.57								
CH 116	5580	15.60								
CH 132	5660	15.16								
CH 136	5680	14.88								
CH 140	5700	14.82								
CH 149	5745	14.59	CH 157	14.98	15.04	14.99	14.86	14.86	14.83	11.65
CH 153	5765	14.71								
CH 157	5785	<b>15.05</b>								
CH 161	5805	14.93								
CH 165	5825	14.91								



WLAN 5G 802.11n (BW 20M) Average Power (dBm)										
Power vs. Channel			Power vs. Data Rate							
Channel	Frequency (MHz)	MCS Index	Channel	MCS Index						
		MCS0		MCS1	MCS2	MCS3	MCS4	MCS5	MCS6	MCS7
CH 36	5180	13.72	CH 48	13.70	13.75	13.78	13.78	12.91	12.88	11.88
CH 40	5200	13.70								
CH 44	5220	13.65								
CH 48	5240	<b>13.80</b>								
CH 52	5260	13.86	CH 64	14.26	14.23	14.25	14.25	12.84	12.83	11.79
CH 56	5280	14.13								
CH 60	5300	13.82								
CH 64	5320	<b>14.27</b>								
CH 100	5500	<b>14.69</b>	CH 100	14.53	14.52	14.53	14.41	13.28	13.42	12.37
CH 104	5520	14.45								
CH 108	5540	14.43								
CH 112	5560	14.59								
CH 116	5580	14.36								
CH 132	5660	14.18								
CH 136	5680	13.85								
CH 140	5700	13.68								
CH 149	5745	13.55	CH 161	13.94	13.91	13.88	13.9	13.84	13.81	13.83
CH 153	5765	13.61								
CH 157	5785	13.93								
CH 161	5805	<b>13.99</b>								
CH 165	5825	13.79								

WLAN 5G 802.11n (BW 40M) Average Power (dBm)										
Power vs. Channel			Power vs. Data Rate							
Channel	Frequency (MHz)	MCS Index	Channel	MCS Index						
		MCS0		MCS1	MCS2	MCS3	MCS4	MCS5	MCS6	MCS7
CH 38	5190	13.51	CH 46	13.70	13.60	13.62	13.76	12.61	12.69	11.65
CH 46	5230	<b>13.84</b>								
CH 54	5270	<b>13.93</b>	CH 54	13.90	13.76	13.88	13.91	12.65	12.67	11.66
CH 62	5310	13.73								
CH 102	5510	<b>13.50</b>	CH 102	13.44	13.4	13.35	13.31	13.24	13.27	13.22
CH 134	5670	13.43								
CH 151	5755	13.23	CH 159	13.68	13.72	13.75	13.82	12.70	12.77	11.66
CH 159	5795	<b>13.68</b>								

Note:

1. Per KDB 248227, choose the highest output power channel to test SAR and determine further SAR exclusion
2. Per KDB 248227, 11n output power is less than 1/4 dB higher than 11a mode, thus the SAR can be excluded.
3. For each frequency band, testing at higher data rates and higher order modulations is not required when the maximum average output power for each of these configurations is less than 1/4 dB higher than those measured at the lowest data rate.



## 11. SAR Test Results

### 11.1 Test Records for Head SAR Test

<GSM>

Plot No.	Band	Mode	Test Position	Ch.	Freq. (MHz)	Sample	Battery	Power Drift (dB)	SAR <sub>1g</sub> (W/kg)	SAR <sub>10g</sub> (W/kg)
1	GSM850	GPRS12	Right Cheek	128	824.2	1	1	-0.16	0.177	0.140
2	GSM850	GPRS12	Right Tilted	128	824.2	1	1	0.14	0.118	0.093
3	<b>GSM850</b>	<b>GPRS12</b>	<b>Left Cheek</b>	<b>128</b>	<b>824.2</b>	<b>1</b>	<b>1</b>	<b>0.15</b>	<b>0.213</b>	<b>0.159</b>
4	GSM850	GPRS12	Left Tilted	128	824.2	1	1	0.1	0.131	0.102
63	GSM850	GPRS12	Left Cheek	128	824.2	2	2	-0.065	0.209	0.155
9	GSM1900	GPRS12	Right Cheek	810	1909.8	1	1	0.18	0.398	0.248
10	GSM1900	GPRS12	Right Tilted	810	1909.8	1	1	-0.12	0.306	0.169
11	<b>GSM1900</b>	<b>GPRS12</b>	<b>Left Cheek</b>	<b>810</b>	<b>1909.8</b>	<b>1</b>	<b>1</b>	<b>0.19</b>	<b>0.669</b>	<b>0.400</b>
12	GSM1900	GPRS12	Left Tilted	810	1909.8	1	1	0.12	0.300	0.171
64	GSM1900	GPRS12	Left Cheek	810	1909.8	2	2	-0.091	0.467	0.299

**Note:** Per KDB 447498, if the highest output channel SAR for each exposure position  $\leq 0.8$  W/kg other channels SAR tests are not necessary.

<UMTS>

Plot No.	Band	Mode	Test Position	Ch.	Freq. (MHz)	Sample	Battery	Power Drift (dB)	SAR <sub>1g</sub> (W/kg)	SAR <sub>10g</sub> (W/kg)
5	WCDMA V	RMC12.2K	Right Cheek	4132	826.4	1	1	0.18	0.123	0.096
6	WCDMA V	RMC12.2K	Right Tilted	4132	826.4	1	1	0.1	0.088	0.068
7	<b>WCDMA V</b>	<b>RMC12.2K</b>	<b>Left Cheek</b>	<b>4132</b>	<b>826.4</b>	<b>1</b>	<b>1</b>	<b>0.12</b>	<b>0.15</b>	<b>0.116</b>
8	WCDMA V	RMC12.2K	Left Tilted	4132	826.4	1	1	0.14	0.092	0.072
65	WCDMA V	RMC12.2K	Left Cheek	4132	826.4	2	2	-0.042	0.142	0.102
13	WCDMA II	RMC12.2K	Right Cheek	9262	1852.4	1	1	-0.11	0.423	0.264
14	WCDMA II	RMC12.2K	Right Tilted	9262	1852.4	1	1	-0.19	0.294	0.165
15	<b>WCDMA II</b>	<b>RMC12.2K</b>	<b>Left Cheek</b>	<b>9262</b>	<b>1852.4</b>	<b>1</b>	<b>1</b>	<b>0.16</b>	<b>0.653</b>	<b>0.393</b>
16	WCDMA II	RMC12.2K	Left Tilted	9262	1852.4	1	1	-0.12	0.274	0.161
66	WCDMA II	RMC12.2K	Left Cheek	9262	1852.4	2	2	-0.023	0.514	0.341

**Note:** Per KDB 447498, if the highest output channel SAR for each exposure position  $\leq 0.8$  W/kg other channels SAR tests are not necessary.



<WLAN>

Plot No.	Band	Mode	Test Position	Ch.	Freq. (MHz)	Sample	Battery	Power Drift (dB)	SAR <sub>1g</sub> (W/kg)	SAR <sub>10g</sub> (W/kg)
118	WLAN2.4G	802.11b	Right Cheek	1	2412	1	1	0.048	0.364	0.197
119	WLAN2.4G	802.11b	Right Tilted	1	2412	1	1	-0.022	0.378	0.196
120	<b>WLAN2.4G</b>	<b>802.11b</b>	<b>Left Cheek</b>	<b>1</b>	<b>2412</b>	<b>1</b>	<b>1</b>	<b>0.127</b>	<b>0.634</b>	<b>0.318</b>
121	WLAN2.4G	802.11b	Left Tilted	1	2412	1	1	-0.012	0.437	0.219
122	WLAN2.4G	802.11b	Left Cheek	1	2412	2	2	0.009	0.595	0.299
98	WLAN5G	802.11a	Right Cheek	48	5240	1	1	0.189	0.020	0.00581
99	WLAN5G	802.11a	Right Tilted	48	5240	1	1	0.154	0.00388	0.000577
100	WLAN5G	802.11a	Left Cheek	48	5240	1	1	0.108	0.057	0.019
101	WLAN5G	802.11a	Left Tilted	48	5240	1	1	0.131	0.00185	0.000226
102	WLAN5G	802.11a	Left Cheek	48	5240	2	2	0.169	0.030	0.011
103	WLAN5G	802.11a	Right Cheek	60	5300	1	1	0.013	0.021	0.00853
104	WLAN5G	802.11a	Right Tilted	60	5300	1	1	0.017	0.013	0.00348
105	WLAN5G	802.11a	Left Cheek	60	5300	1	1	-0.175	0.079	0.023
106	WLAN5G	802.11a	Left Tilted	60	5300	1	1	0.105	0.035	0.011
107	WLAN5G	802.11a	Left Cheek	60	5300	2	2	0.152	0.071	0.023
108	WLAN5G	802.11a	Right Cheek	100	5500	1	1	0.162	0.033	0.012
109	WLAN5G	802.11a	Right Tilted	100	5500	1	1	0.001	0.027	0.00929
110	<b>WLAN5G</b>	<b>802.11a</b>	<b>Left Cheek</b>	<b>100</b>	<b>5500</b>	<b>1</b>	<b>1</b>	<b>-0.131</b>	<b>0.144</b>	<b>0.044</b>
111	WLAN5G	802.11a	Left Tilted	100	5500	1	1	0.159	0.032	0.014
112	WLAN5G	802.11a	Left Cheek	100	5500	2	2	0.172	0.133	0.039
113	WLAN5G	802.11a	Right Cheek	157	5785	1	1	0.001	0.027	0.00851
114	WLAN5G	802.11a	Right Tilted	157	5785	1	1	0	0.043	0.015
115	WLAN5G	802.11a	Left Cheek	157	5785	1	1	0.158	0.068	0.018
116	WLAN5G	802.11a	Left Tilted	157	5785	1	1	-0.151	0.038	0.012
117	WLAN5G	802.11a	Left Cheek	157	5785	2	2	-0.187	0.048	0.015

Note: Per KDB 248227, if the highest output channel SAR for each exposure position ≤ 0.8 W/kg other channels SAR tests are not necessary.



11.2 Test Records for Hotspot SAR Test

<GSM>

Plot No.	Band	Mode	Test Position	Gap (cm)	Ch.	Freq. (MHz)	Sample	Battery	Power Drift (dB)	SAR <sub>1g</sub> (W/kg)	SAR <sub>10g</sub> (W/kg)
17	GSM850	GPRS12	Front	1	128	824.2	1	1	-0.05	0.312	0.239
18	GSM850	GPRS12	Back	1	128	824.2	1	1	0.01	0.335	0.257
19	<b>GSM850</b>	<b>GPRS12</b>	<b>Left Side</b>	<b>1</b>	<b>128</b>	<b>824.2</b>	<b>1</b>	<b>1</b>	<b>-0.07</b>	<b>0.364</b>	<b>0.257</b>
79	GSM850	GPRS12	Left Side	1	128	824.2	2	2	-0.184	0.361	0.256
20	GSM850	GPRS12	Right Side	1	128	824.2	1	1	-0.01	0.245	0.168
22	GSM850	GPRS12	Bottom Side	1	128	824.2	1	1	0.01	0.169	0.082
29	GSM1900	GPRS12	Front	1	810	1909.8	1	1	-0.07	0.770	0.427
30	GSM1900	GPRS12	Back	1	512	1850.2	1	1	-0.08	1.14	0.670
31	GSM1900	GPRS12	Back	1	661	1880	1	1	0.12	1.29	0.729
32	<b>GSM1900</b>	<b>GPRS12</b>	<b>Back</b>	<b>1</b>	<b>810</b>	<b>1909.8</b>	<b>1</b>	<b>1</b>	<b>-0.09</b>	<b>1.31</b>	<b>0.727</b>
73	GSM1900	GPRS12	Back	1	512	1850.2	2	2	-0.09	1.08	0.645
74	GSM1900	GPRS12	Back	1	661	1880	2	2	-0.122	1.13	0.652
75	GSM1900	GPRS12	Back	1	810	1909.8	2	2	-0.13	1.23	0.696
33	GSM1900	GPRS12	Left Side	1	810	1909.8	1	1	0.06	0.319	0.187
34	GSM1900	GPRS12	Right Side	1	810	1909.8	1	1	0.05	0.173	0.105
36	GSM1900	GPRS12	Bottom Side	1	512	1850.2	1	1	0.08	0.863	0.469
37	GSM1900	GPRS12	Bottom Side	1	661	1880	1	1	0.15	1.02	0.544
38	GSM1900	GPRS12	Bottom Side	1	810	1909.8	1	1	0.08	1.07	0.559

Note:

1. Per KDB 941225 D06, for EUT dimension ≥ 9cm\*5cm, the test distance is 1cm. SAR must be measured for all surfaces and sides with a transmitting antenna located within 2.5cm from that surface or edge.
2. As in (1), SAR for Front / Back / Bottom Side / Left Side / Right Side is necessary.
3. Per KDB 447498 if the highest output channel SAR for each exposure position ≤ 0.8 W/kg other channels SAR tests are not necessary.
4. If GPRS class 12 measured SAR is > 0.8W/kg, EDGE class 12 (MCS1) SAR is measured following KDB 941225 D03 and IEEE std-1528 footnote 11.



<UMTS>

Plot No.	Band	Mode	Test Position	Gap (cm)	Ch.	Freq. (MHz)	Sample	Battery	Power Drift (dB)	SAR <sub>1g</sub> (W/kg)	SAR <sub>10g</sub> (W/kg)
23	WCDMA V	RMC12.2K	Front	1	4132	826.4	1	1	-0.02	0.272	0.209
81	WCDMA V	RMC12.2K	Front	1	4132	826.4	2	2	-0.146	0.270	0.209
24	WCDMA V	RMC12.2K	Back	1	4132	826.4	1	1	-0.05	0.225	0.173
25	WCDMA V	RMC12.2K	Left Side	1	4132	826.4	1	1	-0.01	0.259	0.179
26	WCDMA V	RMC12.2K	Right Side	1	4132	826.4	1	1	0.01	0.164	0.113
28	WCDMA V	RMC12.2K	Bottom Side	1	4132	826.4	1	1	0.01	0.115	0.056
39	WCDMA II	RMC12.2K	Front	1	9262	1852.4	1	1	0.05	0.681	0.408
40	WCDMA II	RMC12.2K	Back	1	9262	1852.4	1	1	-0.04	1.05	0.610
41	WCDMA II	RMC12.2K	Back	1	9400	1880	1	1	-0.07	1.09	0.618
42	WCDMA II	RMC12.2K	Back	1	9538	1907.6	1	1	-0.03	1.1	0.608
67	WCDMA II	RMC12.2K	Back	1	9538	1907.6	2	2	-0.19	1.07	0.600
68	WCDMA II	RMC12.2K	Back	1	9262	1852.4	2	2	-0.14	1.01	0.600
69	WCDMA II	RMC12.2K	Back	1	9400	1880	2	2	-0.148	1.04	0.591
43	WCDMA II	RMC12.2K	Left Side	1	9262	1852.4	1	1	0.15	0.276	0.164
44	WCDMA II	RMC12.2K	Right Side	1	9262	1852.4	1	1	-0.13	0.151	0.091
46	WCDMA II	RMC12.2K	Bottom Side	1	9262	1852.4	1	1	0.124	0.771	0.417

Note:

1. Per KDB 941225 D06, for EUT dimension ≥ 9cm\*5cm, the test distance is 1cm. SAR must be measured for all surfaces and sides with a transmitting antenna located within 2.5cm from that surface or edge.
2. As in (1), SAR for Front / Back / Bottom Side / Left Side / Right Side is necessary.
3. Per KDB 447498, if the highest output channel SAR for each exposure position ≤ 0.8 W/kg other channels SAR tests are not necessary.

<WLAN>

Plot No.	Band	Mode	Test Position	Gap (cm)	Ch.	Freq. (MHz)	Sample	Battery	Power Drift (dB)	SAR <sub>1g</sub> (W/kg)	SAR <sub>10g</sub> (W/kg)
125	WLAN2.4G	802.11b	Front	1	1	2412	1	1	0.197	0.142	0.081
126	WLAN2.4G	802.11b	Back	1	1	2412	1	1	0.19	0.178	0.098
130	WLAN2.4G	802.11b	Back	1	1	2412	2	2	0.141	0.165	0.080
127	WLAN2.4G	802.11b	Right Side	1	1	2412	1	1	0.176	0.126	0.065
128	WLAN2.4G	802.11b	Top Side	1	1	2412	1	1	0.191	0.122	0.065



Plot No.	Band	Mode	Test Position	Gap (cm)	Ch.	Freq. (MHz)	Sample	Battery	Power Drift (dB)	SAR <sub>1g</sub> (W/kg)	SAR <sub>10g</sub> (W/kg)
83	WLAN5G	802.11a	Front	1	48	5240	1	1	0.116	0.036	0.014
84	WLAN5G	802.11a	Back	1	48	5240	1	1	0.141	0.116	0.037
86	WLAN5G	802.11a	Right Side	1	48	5240	1	1	0.154	0.087	0.029
87	WLAN5G	802.11a	Top Side	1	48	5240	1	1	0.102	0.019	0.00812
89	WLAN5G	802.11a	Back	1	48	5240	2	2	0.143	0.087	0.025
92	WLAN5G	802.11a	Front	1	60	5300	1	1	0.013	0.0091	0.00175
93	WLAN5G	802.11a	Back	1	60	5300	1	1	-0.134	0.154	0.052
95	WLAN5G	802.11a	Right Side	1	60	5300	1	1	0.001	0.089	0.030
96	WLAN5G	802.11a	Top Side	1	60	5300	1	1	0.016	0.022	0.00884
97	WLAN5G	802.11a	Back	1	60	5300	2	2	0.12	0.134	0.038
100	WLAN5G	802.11a	Front	1	100	5500	1	1	0.01	0.024	0.00984
101	WLAN5G	802.11a	Back	1	100	5500	1	1	0.157	0.263	0.096
102	WLAN5G	802.11a	Right Side	1	100	5500	1	1	-0.032	0.213	0.076
103	WLAN5G	802.11a	Top Side	1	100	5500	1	1	0.108	0.043	0.018
<b>104</b>	<b>WLAN5G</b>	<b>802.11a</b>	<b>Back</b>	<b>1</b>	<b>100</b>	<b>5500</b>	<b>2</b>	<b>2</b>	<b>0.073</b>	<b>0.266</b>	<b>0.094</b>
132	WLAN5G	802.11a	Front	1	157	5785	1	1	0.13	0.023	0.00815
133	WLAN5G	802.11a	Back	1	157	5785	1	1	0.096	0.185	0.056
134	WLAN5G	802.11a	Right Side	1	157	5785	1	1	0.051	0.096	0.034
135	WLAN5G	802.11a	Top Side	1	157	5785	1	1	0.194	0.033	0.014
136	WLAN5G	802.11a	Back	1	157	5785	2	2	0.12	0.181	0.058

**Note:**

1. Per KDB 941225 D06, for EUT dimension  $\geq 9\text{cm} \times 5\text{cm}$ , the test distance is 1cm. SAR must be measured for all surfaces and sides with a transmitting antenna located within 2.5cm from that surface or edge.
2. As in (1), SAR for Front / Back / Top Side / Right Side is necessary.
3. Per KDB 248227, if the highest output channel SAR for each exposure position  $\leq 0.8 \text{ W/kg}$  other channels SAR tests are not necessary.





**11.3 Test Records for Body-worn SAR Test**

<GSM>

Plot No.	Band	Mode	Test Position	Gap (cm)	Ch.	Freq. (MHz)	Sample	Battery	Headset	Power Drift (dB)	SAR <sub>1g</sub> (W/kg)	SAR <sub>10g</sub> (W/kg)
17	GSM850	GPRS12	Front	1	128	824.2	1	1	-	-0.05	0.312	0.239
18	GSM850	GPRS12	Back	1	128	824.2	1	1	-	0.01	0.335	0.257
<b>59</b>	<b>GSM850</b>	<b>GPRS12</b>	<b>Back</b>	<b>1</b>	<b>128</b>	<b>824.2</b>	<b>1</b>	<b>1</b>	<b>1</b>	<b>0.1</b>	<b>0.361</b>	<b>0.216</b>
80	GSM850	GPRS12	Back	1	128	824.2	2	2	2	-0.03	0.356	0.221
139	GSM850	GPRS12	Back	1	128	824.2	1	1	3	-0.101	0.326	0.193
29	GSM1900	GPRS12	Front	1	810	1909.8	1	1	-	-0.07	0.77	0.427
30	GSM1900	GPRS12	Back	1	512	1850.2	1	1	-	-0.08	1.14	0.670
31	GSM1900	GPRS12	Back	1	661	1880	1	1	-	0.12	1.29	0.729
<b>32</b>	<b>GSM1900</b>	<b>GPRS12</b>	<b>Back</b>	<b>1</b>	<b>810</b>	<b>1909.8</b>	<b>1</b>	<b>1</b>	<b>-</b>	<b>-0.09</b>	<b>1.31</b>	<b>0.727</b>
73	GSM1900	GPRS12	Back	1	512	1850.2	2	2	-	-0.09	1.08	0.645
74	GSM1900	GPRS12	Back	1	661	1880	2	2	-	-0.122	1.13	0.652
75	GSM1900	GPRS12	Back	1	810	1909.8	2	2	-	-0.13	1.23	0.696
53	GSM1900	GPRS12	Back	1	512	1850.2	1	1	1	-0.004	0.986	0.559
54	GSM1900	GPRS12	Back	1	661	1880	1	1	1	-0.065	1.12	0.652
55	GSM1900	GPRS12	Back	1	810	1909.8	1	1	1	-0.095	1.19	0.674
76	GSM1900	GPRS12	Back	1	512	1850.2	2	2	2	-0.1	0.977	0.585
77	GSM1900	GPRS12	Back	1	661	1880	2	2	2	-0.04	1.1	0.654
78	GSM1900	GPRS12	Back	1	810	1909.8	2	2	2	-0.146	1.1	0.626
141	GSM1900	GPRS12	Back	1	512	1850.2	1	1	3	0.178	1.1	0.630
142	GSM1900	GPRS12	Back	1	661	1880	1	1	3	-0.003	1.09	0.612
143	GSM1900	GPRS12	Back	1	810	1909.8	1	1	3	-0.096	1.08	0.595

**Note:**

1. Per KDB 447498, if the highest output channel SAR for each exposure position ≤ 0.8 W/kg other channels SAR tests are not necessary.
2. If GPRS class 12 measured SAR is > 0.8W/kg, EDGE class 12 (MCS1) SAR is measured following KDB 941225 D03 and IEEE std-1528 footnote 11.
3. 1 and 2 and 3 in the Headset column means the Headset is plugged during SAR testing.



<UMTS>

Plot No.	Band	Mode	Test Position	Gap (cm)	Ch.	Freq. (MHz)	Sample	Battery	Headset	Power Drift (dB)	SAR <sub>1g</sub> (W/kg)	SAR <sub>10g</sub> (W/kg)
<b>23</b>	<b>WCDMA V</b>	<b>RMC12.2K</b>	<b>Front</b>	<b>1</b>	<b>4132</b>	<b>826.4</b>	<b>1</b>	<b>1</b>	<b>-</b>	<b>-0.02</b>	<b>0.272</b>	<b>0.209</b>
81	WCDMA V	RMC12.2K	Front	1	4132	826.4	2	2	-	-0.146	0.270	0.209
24	WCDMA V	RMC12.2K	Back	1	4132	826.4	1	1	-	-0.05	0.225	0.173
61	WCDMA V	RMC12.2K	Front	1	4132	826.4	1	1	1	0.042	0.191	0.153
82	WCDMA V	RMC12.2K	Front	1	4132	826.4	2	2	2	-0.02	0.15	0.120
140	WCDMA V	RMC12.2K	Front	1	4132	826.4	1	1	3	-0.181	0.19	0.149
39	WCDMA II	RMC12.2K	Front	1	9262	1852.4	1	1	-	0.05	0.681	0.408
40	WCDMA II	RMC12.2K	Back	1	9262	1852.4	1	1	-	-0.04	1.05	0.61
41	WCDMA II	RMC12.2K	Back	1	9400	1880	1	1	-	-0.07	1.09	0.618
<b>42</b>	<b>WCDMA II</b>	<b>RMC12.2K</b>	<b>Back</b>	<b>1</b>	<b>9538</b>	<b>1907.6</b>	<b>1</b>	<b>1</b>	<b>-</b>	<b>-0.03</b>	<b>1.1</b>	<b>0.608</b>
67	WCDMA II	RMC12.2K	Back	1	9538	1907.6	2	2	-	-0.19	1.07	0.600
68	WCDMA II	RMC12.2K	Back	1	9262	1852.4	2	2	-	-0.14	1.01	0.600
69	WCDMA II	RMC12.2K	Back	1	9400	1880	2	2	-	-0.148	1.04	0.591
47	WCDMA II	RMC12.2K	Back	1	9262	1852.4	1	1	1	0.14	1.01	0.589
48	WCDMA II	RMC12.2K	Back	1	9400	1880	1	1	1	-0.07	1.04	0.592
49	WCDMA II	RMC12.2K	Back	1	9538	1907.6	1	1	1	0.03	1.02	0.564
70	WCDMA II	RMC12.2K	Back	1	9538	1907.6	2	2	2	0.16	0.961	0.548
71	WCDMA II	RMC12.2K	Back	1	9262	1852.4	2	2	2	-0.12	0.943	0.566
72	WCDMA II	RMC12.2K	Back	1	9400	1880	2	2	2	-0.18	0.923	0.538
144	WCDMA II	RMC12.2K	Back	1	9262	1852.4	1	1	3	0.058	0.907	0.525
145	WCDMA II	RMC12.2K	Back	1	9400	1880	1	1	3	0.032	0.833	0.473
146	WCDMA II	RMC12.2K	Back	1	9538	1907.6	1	1	3	-0.073	0.863	0.478

Note:

1. Per KDB 447498, if the highest output channel SAR for each exposure position ≤ 0.8 W/kg other channels SAR tests are not necessary.
2. 1 and 2 and 3 in the Headset column means the Headset is plugged during SAR testing.



<WLAN>

Plot No.	Band	Mode	Test Position	Gap (cm)	Ch.	Freq. (MHz)	Sample	Battery	Headset	Power Drift (dB)	SAR <sub>1g</sub> (W/kg)	SAR <sub>10g</sub> (W/kg)
125	WLAN2.4G	802.11b	Front	1	1	2412	1	1	-	0.197	0.142	0.081
126	<b>WLAN2.4G</b>	<b>802.11b</b>	<b>Back</b>	<b>1</b>	<b>1</b>	<b>2412</b>	<b>1</b>	<b>1</b>	-	<b>0.19</b>	<b>0.178</b>	<b>0.098</b>
129	WLAN2.4G	802.11b	Back	1	1	2412	1	1	1	0.135	0.173	0.086
131	WLAN2.4G	802.11b	Back	1	1	2412	2	2	2	0.183	0.155	0.075
147	WLAN2.4G	802.11b	Back	1	1	2412	1	1	3	0.125	0.156	0.078
83	WLAN5G	802.11a	Front	1	48	5240	1	1	-	0.116	0.036	0.014
84	WLAN5G	802.11a	Back	1	48	5240	1	1	-	0.141	0.116	0.037
90	WLAN5G	802.11a	Back	1	48	5240	1	1	1	-0.05	0.115	0.037
91	WLAN5G	802.11a	Back	1	48	5240	2	2	2	0.139	0.085	0.025
148	WLAN5G	802.11a	Back	1	48	5240	1	1	3	0.174	0.154	0.051
92	WLAN5G	802.11a	Front	1	60	5300	1	1	-	0.013	0.0091	0.00175
93	WLAN5G	802.11a	Back	1	60	5300	1	1	-	-0.134	0.154	0.052
98	WLAN5G	802.11a	Back	1	60	5300	1	1	1	-0.104	0.152	0.052
99	WLAN5G	802.11a	Back	1	60	5300	2	2	2	0.176	0.132	0.047
149	WLAN5G	802.11a	Back	1	60	5300	1	1	3	0.139	0.173	0.053
100	WLAN5G	802.11a	Front	1	100	5500	1	1	-	0.01	0.024	0.00984
101	WLAN5G	802.11a	Back	1	100	5500	1	1	-	0.157	0.263	0.096
105	WLAN5G	802.11a	Back	1	100	5500	1	1	1	0.055	0.269	0.096
106	WLAN5G	802.11a	Back	1	100	5500	2	2	2	-0.113	0.264	0.094
150	<b>WLAN5G</b>	<b>802.11a</b>	<b>Back</b>	<b>1</b>	<b>100</b>	<b>5500</b>	<b>1</b>	<b>1</b>	<b>3</b>	<b>0.192</b>	<b>0.276</b>	<b>0.095</b>
132	WLAN5G	802.11a	Front	1	157	5785	1	1	-	0.13	0.023	0.00815
133	WLAN5G	802.11a	Back	1	157	5785	1	1	-	0.096	0.185	0.056
137	WLAN5G	802.11a	Back	1	157	5785	1	1	1	0.084	0.187	0.057
138	WLAN5G	802.11a	Back	1	157	5785	2	2	2	0.145	0.183	0.058
151	WLAN5G	802.11a	Back	1	157	5785	1	1	3	0.151	0.218	0.076

Note:

- Per KDB 248227, if the highest output channel SAR for each exposure position ≤ 0.8 W/kg other channels SAR tests are not necessary.
- 1 and 2 and 3 in the Headset column means the Headset is plugged during SAR testing.

**11.4 Simultaneous Multi-band Transmission Analysis**

No.	Applicable Simultaneous Transmission Combination
1	2G/3G + BT
2	2G/3G + WLAN2.4G
3	2G/3G + WLAN5G

Note:

- WLAN and BT share the same antenna, and cannot transmit simultaneously.
- GSM and WCDMA share the same antenna, and cannot transmit simultaneously.
- EUT will choose either WLAN2.4G or WLAN5G according to the network signal condition; therefore, they will not transmit simultaneously.
- EUT will choose either GSM or WCDMA according to the network signal condition; therefore, they will not transmit simultaneously.



<Head SAR>

Position	WWAN			Scaled WWAN				WLAN2.4G		Max. SAR Summation	Scaled WWAN + WLAN
	WWAN Band	Plot No	Max. WWAN SAR (W/kg)	Average Power (dBm)	Tune-up Limit (dBm)	Scaling Factor	Scaled WWAN (W/kg)	Plot No	Max. WLAN SAR (W/kg)		
Right Cheek	GSM850	1	0.177	29.54	30	1.112	0.197	118	0.364	0.54	0.56
	GSM1900	9	0.398	27.55	28	1.109	0.441	118	0.364	0.76	0.81
	WCDMA V	5	0.123	23.58	24	1.102	0.135	118	0.364	0.49	0.50
	WCDMA II	13	0.423	23.46	24	1.132	0.479	118	0.364	0.79	0.84
Right Tilted	GSM850	2	0.118	29.54	30	1.112	0.131	119	0.378	0.50	0.51
	GSM1900	10	0.306	27.55	28	1.109	0.339	119	0.378	0.68	0.72
	WCDMA V	6	0.088	23.58	24	1.102	0.097	119	0.378	0.47	0.48
	WCDMA II	14	0.294	23.46	24	1.132	0.333	119	0.378	0.67	0.71
Left Cheek	GSM850	3	0.213	29.54	30	1.112	0.237	120	0.634	0.85	0.87
	GSM1900	11	0.669	27.55	28	1.109	0.742	120	0.634	1.30	1.38
	WCDMA V	7	0.15	23.58	24	1.102	0.165	120	0.634	0.78	0.80
	WCDMA II	15	0.653	23.46	24	1.132	0.739	120	0.634	1.29	1.37
Left Tilted	GSM850	4	0.131	29.54	30	1.112	0.146	121	0.437	0.57	0.58
	GSM1900	12	0.3	27.55	28	1.109	0.333	121	0.437	0.74	0.77
	WCDMA V	8	0.092	23.58	24	1.102	0.101	121	0.437	0.53	0.54
	WCDMA II	16	0.274	23.46	24	1.132	0.310	121	0.437	0.71	0.75

Position	WWAN			Scaled WWAN				WLAN5G		Max. SAR Summation	Scaled WWAN + WLAN
	WWAN Band	Plot No	Max. WWAN SAR (W/kg)	Average Power (dBm)	Tune-up Limit (dBm)	Scaling Factor	Scaled WWAN (W/kg)	Plot No	Max. WLAN SAR (W/kg)		
Right Cheek	GSM850	1	0.177	29.54	30	1.112	0.197	108	0.033	0.21	0.23
	GSM1900	9	0.398	27.55	28	1.109	0.441	108	0.033	0.43	0.47
	WCDMA V	5	0.123	23.58	24	1.102	0.135	108	0.033	0.16	0.17
	WCDMA II	13	0.423	23.46	24	1.132	0.479	108	0.033	0.46	0.51
Right Tilted	GSM850	2	0.118	29.54	30	1.112	0.131	114	0.043	0.16	0.17
	GSM1900	10	0.306	27.55	28	1.109	0.339	114	0.043	0.35	0.38
	WCDMA V	6	0.088	23.58	24	1.102	0.097	114	0.043	0.13	0.14
	WCDMA II	14	0.294	23.46	24	1.132	0.333	114	0.043	0.34	0.38
Left Cheek	GSM850	3	0.213	29.54	30	1.112	0.237	110	0.144	0.36	0.38
	GSM1900	11	0.669	27.55	28	1.109	0.742	110	0.144	0.81	0.89
	WCDMA V	7	0.15	23.58	24	1.102	0.165	110	0.144	0.29	0.31
	WCDMA II	15	0.653	23.46	24	1.132	0.739	110	0.144	0.80	0.88
Left Tilted	GSM850	4	0.131	29.54	30	1.112	0.146	116	0.038	0.17	0.18
	GSM1900	12	0.3	27.55	28	1.109	0.333	116	0.038	0.34	0.37
	WCDMA V	8	0.092	23.58	24	1.102	0.101	116	0.038	0.13	0.14
	WCDMA II	16	0.274	23.46	24	1.132	0.310	116	0.038	0.31	0.35

Note:

1. The maximum SAR summation is calculated based on the same configuration and test position.
2. When stand-alone 1-g SAR is not required for a transmitter or antenna, its SAR is considered zero in the 1-g SAR summing process to determine simultaneous transmission SAR evaluation requirements
3. If 1g-SAR scalar summation < 1.6W/kg, simultaneous SAR measurement is not necessary.
4. If 1g-SAR summation > 1.6W/kg, SPLSR calculation is necessary.
5. The WWAN scaling factor is calculated according to the difference between measured output power and maximum tolerance power on this device.



<Hotspot SAR>

Position	WWAN			Scaled WWAN				WLAN2.4G		Max. SAR Summation	Scaled WWAN + WLAN
	WWAN Band	Plot No	Max. WWAN SAR (W/kg)	Average Power (dBm)	Tune-up Limit (dBm)	Scaling Factor	Scaled WWAN (W/kg)	Plot No	Max. WLAN SAR (W/kg)		
Front	GSM850	17	0.312	29.54	30	1.112	0.347	125	0.142	0.45	0.49
	GSM1900	29	0.77	27.55	28	1.109	0.854	125	0.142	0.91	1.00
	WCDMA V	23	0.272	23.58	24	1.102	0.300	125	0.142	0.41	0.44
	WCDMA II	39	0.681	23.46	24	1.132	0.771	125	0.142	0.82	0.91
Back	GSM850	18	0.335	29.54	30	1.112	0.372	126	0.178	0.51	0.55
	<b>GSM1900</b>	<b>32</b>	<b>1.31</b>	<b>27.55</b>	<b>28</b>	<b>1.109</b>	<b>1.453</b>	<b>126</b>	<b>0.178</b>	<b>1.49</b>	<b>1.63</b>
	WCDMA V	24	0.225	23.58	24	1.102	0.248	126	0.178	0.40	0.43
	WCDMA II	42	1.1	23.3	24	1.175	1.292	126	0.178	1.28	1.47
Left Side	GSM850	19	0.364	29.54	30	1.112	0.405	-	0	0.36	0.41
	GSM1900	33	0.319	27.55	28	1.109	0.354	-	0	0.32	0.35
	WCDMA V	25	0.259	23.58	24	1.102	0.285	-	0	0.26	0.29
	WCDMA II	43	0.276	23.46	24	1.132	0.313	-	0	0.28	0.31
Right Side	GSM850	20	0.245	29.54	30	1.112	0.272	127	0.126	0.37	0.40
	GSM1900	34	0.173	27.55	28	1.109	0.192	127	0.126	0.30	0.32
	WCDMA V	26	0.164	23.58	24	1.102	0.181	127	0.126	0.29	0.31
	WCDMA II	44	0.151	23.46	24	1.132	0.171	127	0.126	0.28	0.30
Top Side	GSM850	-	0	0	0	0	0	128	0.122	0.12	0.12
	GSM1900	-	0	0	0	0	0	128	0.122	0.12	0.12
	WCDMA V	-	0	0	0	0	0	128	0.122	0.12	0.12
	WCDMA II	-	0	0	0	0	0	128	0.122	0.12	0.12
Bottom Side	GSM850	22	0.169	29.54	30	1.112	0.188	-	0	0.17	0.19
	GSM1900	38	1.07	27.55	28	1.109	1.187	-	0	1.07	1.19
	WCDMA V	28	0.115	23.58	24	1.102	0.127	-	0	0.12	0.13
	WCDMA II	46	0.771	23.46	24	1.132	0.873	-	0	0.77	0.87

Position	WWAN			Scaled WWAN				WLAN5G		Max. SAR Summation	Scaled WWAN + WLAN
	WWAN Band	Plot No	Max. WWAN SAR (W/kg)	Average Power (dBm)	Tune-up Limit (dBm)	Scaling Factor	Scaled WWAN (W/kg)	Plot No	Max. WLAN SAR (W/kg)		
Front	GSM850	17	0.312	29.54	30	1.112	0.347	83	0.036	0.35	0.38
	GSM1900	29	0.77	27.55	28	1.109	0.854	83	0.036	0.81	0.89
	WCDMA V	23	0.272	23.58	24	1.102	0.300	83	0.036	0.31	0.34
	WCDMA II	39	0.681	23.46	24	1.132	0.771	83	0.036	0.72	0.81
Back	GSM850	18	0.335	29.54	30	1.112	0.372	104	0.266	0.60	0.64
	<b>GSM1900</b>	<b>32</b>	<b>1.31</b>	<b>27.55</b>	<b>28</b>	<b>1.109</b>	<b>1.453</b>	<b>104</b>	<b>0.266</b>	<b>1.58</b>	<b>1.72</b>
	WCDMA V	24	0.225	23.58	24	1.102	0.248	104	0.266	0.49	0.51
	WCDMA II	42	1.1	23.3	24	1.175	1.292	104	0.266	1.37	1.56
Left Side	GSM850	19	0.364	29.54	30	1.112	0.405	-	0	0.36	0.41
	GSM1900	33	0.319	27.55	28	1.109	0.354	-	0	0.32	0.35
	WCDMA V	25	0.259	23.58	24	1.102	0.285	-	0	0.26	0.29
	WCDMA II	43	0.276	23.46	24	1.132	0.313	-	0	0.28	0.31
Right Side	GSM850	20	0.245	29.54	30	1.112	0.272	102	0.213	0.46	0.49
	GSM1900	34	0.173	27.55	28	1.109	0.192	102	0.213	0.39	0.41
	WCDMA V	26	0.164	23.58	24	1.102	0.181	102	0.213	0.38	0.39
	WCDMA II	44	0.151	23.46	24	1.132	0.171	102	0.213	0.36	0.38
Top Side	GSM850	-	0	0	0	0	0	103	0.043	0.04	0.04
	GSM1900	-	0	0	0	0	0	103	0.043	0.04	0.04
	WCDMA V	-	0	0	0	0	0	103	0.043	0.04	0.04
	WCDMA II	-	0	0	0	0	0	103	0.043	0.04	0.04
Bottom Side	GSM850	22	0.169	29.54	30	1.112	0.188	-	0	0.17	0.19
	GSM1900	38	1.07	27.55	28	1.109	1.187	-	0	1.07	1.19
	WCDMA V	28	0.115	23.58	24	1.102	0.127	-	0	0.12	0.13
	WCDMA II	46	0.771	23.46	24	1.132	0.873	-	0	0.77	0.87

Note:

1. The maximum SAR summation is calculated based on the same configuration and test position.
2. When stand-alone 1-g SAR is not required for a transmitter or antenna, its SAR is considered zero in the 1-g SAR summing process to determine simultaneous transmission SAR evaluation requirements
3. If 1g-SAR scalar summation < 1.6W/kg, simultaneous SAR measurement is not necessary.
4. If 1g-SAR summation > 1.6W/kg, SPLSR calculation is necessary.
5. The WWAN scaling factor is calculated according to the difference between measured output power and maximum tolerance power on this device.



<Body-worn SAR>

Position	WWAN			Scaled WWAN				WLAN2.4G		Max. SAR Summation	Scaled WWAN + WLAN
	WWAN Band	Plot No	Max. WWAN SAR (W/kg)	Average Power (dBm)	Tune-up Limit (dBm)	Scaling Factor	Scaled WWAN (W/kg)	Plot No	Max. WLAN SAR (W/kg)		
Front	GSM850	17	0.312	29.54	30	1.112	0.347	125	0.142	0.45	0.49
	GSM1900	29	0.77	27.55	28	1.109	0.854	125	0.142	0.91	1.00
	WCDMA V	23	0.272	23.58	24	1.102	0.300	125	0.142	0.41	0.44
	WCDMA II	39	0.681	23.46	24	1.132	0.771	125	0.142	0.82	0.91
Back	GSM850	18	0.335	29.54	30	1.112	0.372	126	0.178	0.51	0.55
	<b>GSM1900</b>	<b>32</b>	<b>1.31</b>	<b>27.55</b>	<b>28</b>	<b>1.109</b>	<b>1.453</b>	<b>126</b>	<b>0.178</b>	<b>1.49</b>	<b>1.63</b>
	WCDMA V	24	0.225	23.58	24	1.102	0.248	126	0.178	0.40	0.43
	WCDMA II	42	1.1	23.3	24	1.175	1.292	126	0.178	1.28	1.47
Front (with Headset)	WCDMA V	61	0.191	23.58	24	1.102	0.210	-	0	0.19	0.21
Back (with Headset)	GSM850	59	0.361	29.54	30	1.112	0.401	129	0.173	0.53	0.57
	GSM1900	55	1.19	27.55	28	1.109	1.320	129	0.173	1.36	1.49
	WCDMA II	48	1.04	23.35	24	1.161	1.208	129	0.173	1.21	1.38

Position	WWAN			Scaled WWAN				WLAN5G		Max. SAR Summation	Scaled WWAN + WLAN
	WWAN Band	Plot No	Max. WWAN SAR (W/kg)	Average Power (dBm)	Tune-up Limit (dBm)	Scaling Factor	Scaled WWAN (W/kg)	Plot No	Max. WLAN SAR (W/kg)		
Front	GSM850	17	0.312	29.54	30	1.112	0.347	83	0.036	0.35	0.38
	GSM1900	29	0.77	27.55	28	1.109	0.854	83	0.036	0.81	0.89
	WCDMA V	23	0.272	23.58	24	1.102	0.300	83	0.036	0.31	0.34
	WCDMA II	39	0.681	23.46	24	1.132	0.771	83	0.036	0.72	0.81
Back	GSM850	18	0.335	29.54	30	1.112	0.372	104	0.266	0.60	0.64
	<b>GSM1900</b>	<b>32</b>	<b>1.31</b>	<b>27.55</b>	<b>28</b>	<b>1.109</b>	<b>1.453</b>	<b>104</b>	<b>0.266</b>	<b>1.58</b>	<b>1.72</b>
	WCDMA V	24	0.225	23.58	24	1.102	0.248	104	0.266	0.49	0.51
	WCDMA II	42	1.1	23.3	24	1.175	1.292	104	0.266	1.37	1.56
Front (with Headset)	WCDMA V	61	0.191	23.58	24	1.102	0.210	-	0	0.19	0.21
Back (with Headset)	GSM850	59	0.361	29.54	30	1.197	0.426	150	0.276	0.64	0.71
	GSM1900	55	1.19	27.55	28	1.109	1.320	150	0.276	1.47	1.60
	WCDMA II	48	1.04	23.35	24	1.161	1.208	150	0.276	1.32	1.48

Note:

1. The maximum SAR summation is calculated based on the same configuration and test position.
2. When stand-alone 1-g SAR is not required for a transmitter or antenna, its SAR is considered zero in the 1-g SAR summing process to determine simultaneous transmission SAR evaluation requirements
3. If 1g-SAR scalar summation < 1.6W/kg, simultaneous SAR measurement is not necessary.
4. If 1g-SAR summation > 1.6W/kg, SPLSR calculation is necessary.
5. The WWAN scaling factor is calculated according to the difference between measured output power and maximum tolerance power on this device.

11.5 Simultaneous analysis - SPLSR calculation

Plot No	Band	Position	SAR (W/kg)	Gap (cm)	SAR peak location (m)			3D distance (cm)	Pair SAR sum (W/kg)	SPLSR	Simultaneous SAR
					X	Y	Z				
126	WLAN 2.4G	Back	0.178	1	-0.01	0.057	-0.201	12.0	1.63	0.14	Not required
32	GSM1900		1.453	1	-0.01	-0.063	-0.202				
126	WLAN 2.4G	Back	0.175	1	-0.046	0.041	-0.202	11.0	1.63	0.15	Not required
32	GSM1900		1.453	1	-0.01	-0.063	-0.202				

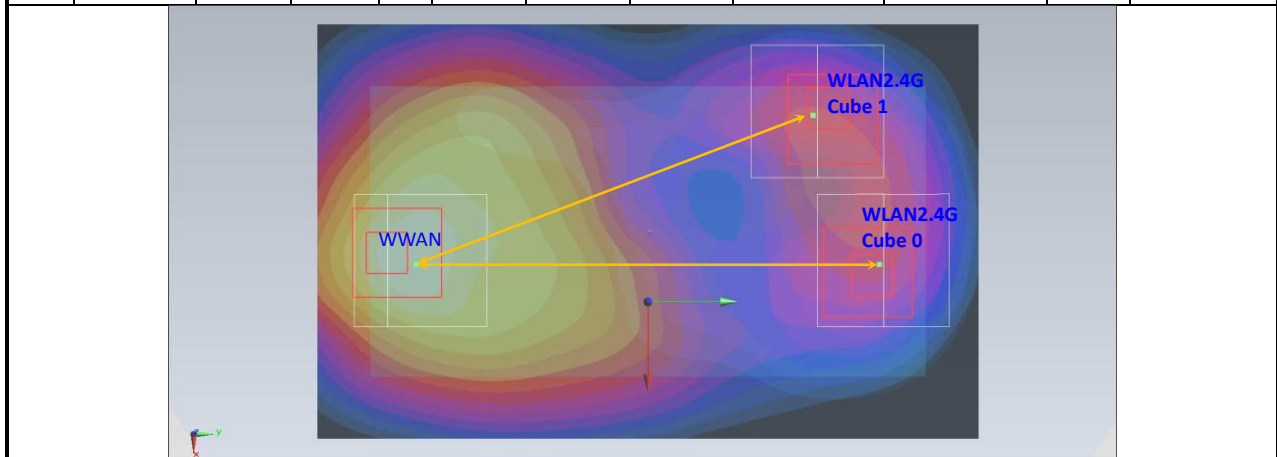

Plot No	Band	Position	SAR (W/kg)	Gap (cm)	SAR peak location (m)			3D distance (cm)	Pair SAR sum (W/kg)	SPLSR	Simultaneous SAR
					X	Y	Z				
104	WLAN 5G	Back	0.266	1	-0.046	0.029	-0.203	9.9	1.72	0.17	Not required
32	GSM1900		1.453	1	-0.01	-0.063	-0.202				

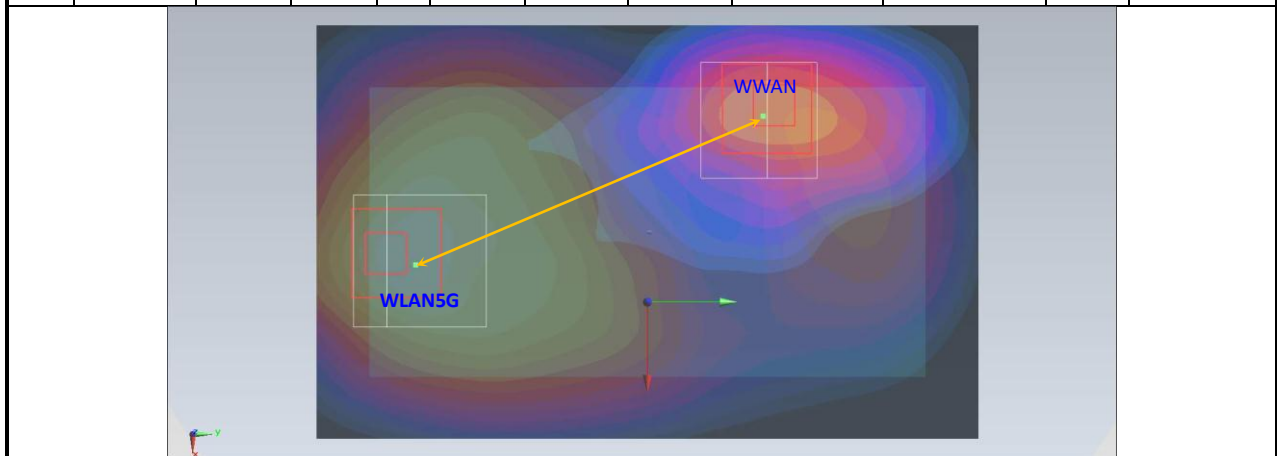

Note: Per KDB 447498, if SPLSR < 0.3, simultaneously transmission SAR is not necessary.

Test Engineer : Bevis Chang, Nick Yu, San Lin, Aaron Chen, Angelo Chang, and Ken Li

## **12. Uncertainty Assessment**

The component of uncertainty may generally be categorized according to the methods used to evaluate them. The evaluation of uncertainty by the statistical analysis of a series of observations is termed a Type A evaluation of uncertainty. The evaluation of uncertainty by means other than the statistical analysis of a series of observations is termed a Type B evaluation of uncertainty. Each component of uncertainty, however evaluated, is represented by an estimated standard deviation, termed standard uncertainty, which is determined by the positive square root of the estimated variance.

A Type A evaluation of standard uncertainty may be based on any valid statistical method for treating data. This includes calculating the standard deviation of the mean of a series of independent observations; using the method of least squares to fit a curve to the data in order to estimate the parameter of the curve and their standard deviations; or carrying out an analysis of variance in order to identify and quantify random effects in certain kinds of measurement.

A type B evaluation of standard uncertainty is typically based on scientific judgment using all of the relevant information available. These may include previous measurement data, experience and knowledge of the behavior and properties of relevant materials and instruments, manufacture's specification, data provided in calibration reports and uncertainties assigned to reference data taken from handbooks. Broadly speaking, the uncertainty is either obtained from an outdoor source or obtained from an assumed distribution, such as the normal distribution, rectangular or triangular distributions indicated in Table 12.1

<b>Uncertainty Distributions</b>	<b>Normal</b>	<b>Rectangular</b>	<b>Triangular</b>	<b>U-Shape</b>
Multi-plying Factor <sup>(a)</sup>	1/k <sup>(b)</sup>	1/√3	1/√6	1/√2

(a) standard uncertainty is determined as the product of the multiplying factor and the estimated range of variations in the measured quantity

(b)  $k$  is the coverage factor

**Table 12.1 Standard Uncertainty for Assumed Distribution**

The combined standard uncertainty of the measurement result represents the estimated standard deviation of the result. It is obtained by combining the individual standard uncertainties of both Type A and Type B evaluation using the usual "root-sum-squares" (RSS) methods of combining standard deviations by taking the positive square root of the estimated variances.

Expanded uncertainty is a measure of uncertainty that defines an interval about the measurement result within which the measured value is confidently believed to lie. It is obtained by multiplying the combined standard uncertainty by a coverage factor. Typically, the coverage factor ranges from 2 to 3. Using a coverage factor allows the true value of a measured quantity to be specified with a defined probability within the specified uncertainty range. For purpose of this document, a coverage factor two is used, which corresponds to confidence interval of about 95 %. The DASY uncertainty Budget is shown in the following tables.





Error Description	Uncertainty Value (±%)	Probability Distribution	Divisor	Ci (1g)	Ci (10g)	Standard Uncertainty (1g)	Standard Uncertainty (10g)
<b>Measurement System</b>							
Probe Calibration	6.0	Normal	1	1	1	± 6.0 %	± 6.0 %
Axial Isotropy	4.7	Rectangular	√3	0.7	0.7	± 1.9 %	± 1.9 %
Hemispherical Isotropy	9.6	Rectangular	√3	0.7	0.7	± 3.9 %	± 3.9 %
Boundary Effects	1.0	Rectangular	√3	1	1	± 0.6 %	± 0.6 %
Linearity	4.7	Rectangular	√3	1	1	± 2.7 %	± 2.7 %
System Detection Limits	1.0	Rectangular	√3	1	1	± 0.6 %	± 0.6 %
Readout Electronics	0.3	Normal	1	1	1	± 0.3 %	± 0.3 %
Response Time	0.8	Rectangular	√3	1	1	± 0.5 %	± 0.5 %
Integration Time	2.6	Rectangular	√3	1	1	± 1.5 %	± 1.5 %
RF Ambient Noise	3.0	Rectangular	√3	1	1	± 1.7 %	± 1.7 %
RF Ambient Reflections	3.0	Rectangular	√3	1	1	± 1.7 %	± 1.7 %
Probe Positioner	0.4	Rectangular	√3	1	1	± 0.2 %	± 0.2 %
Probe Positioning	2.9	Rectangular	√3	1	1	± 1.7 %	± 1.7 %
Max. SAR Eval.	1.0	Rectangular	√3	1	1	± 0.6 %	± 0.6 %
<b>Test Sample Related</b>							
Device Positioning	2.9	Normal	1	1	1	± 2.9 %	± 2.9 %
Device Holder	3.6	Normal	1	1	1	± 3.6 %	± 3.6 %
Power Drift	5.0	Rectangular	√3	1	1	± 2.9 %	± 2.9 %
<b>Phantom and Setup</b>							
Phantom Uncertainty	4.0	Rectangular	√3	1	1	± 2.3 %	± 2.3 %
Liquid Conductivity (Target)	5.0	Rectangular	√3	0.64	0.43	± 1.8 %	± 1.2 %
Liquid Conductivity (Meas.)	2.5	Normal	1	0.64	0.43	± 1.6 %	± 1.1 %
Liquid Permittivity (Target)	5.0	Rectangular	√3	0.6	0.49	± 1.7 %	± 1.4 %
Liquid Permittivity (Meas.)	2.5	Normal	1	0.6	0.49	± 1.5 %	± 1.2 %
<b>Combined Standard Uncertainty</b>						± 11.0 %	± 10.8 %
<b>Coverage Factor for 95 %</b>						K=2	
<b>Expanded Uncertainty</b>						± 22.0 %	± 21.5 %

Table 12.2 Uncertainty Budget of DASY for frequency range 300 MHz to 3 GHz



Error Description	Uncertainty Value (±%)	Probability Distribution	Divisor	Ci (1g)	Ci (10g)	Standard Uncertainty (1g)	Standard Uncertainty (10g)
<b>Measurement System</b>							
Probe Calibration	6.55	Normal	1	1	1	± 6.55 %	± 6.55 %
Axial Isotropy	4.7	Rectangular	√3	0.7	0.7	± 1.9 %	± 1.9 %
Hemispherical Isotropy	9.6	Rectangular	√3	0.7	0.7	± 3.9 %	± 3.9 %
Boundary Effects	2.0	Rectangular	√3	1	1	± 1.2 %	± 1.2 %
Linearity	4.7	Rectangular	√3	1	1	± 2.7 %	± 2.7 %
System Detection Limits	1.0	Rectangular	√3	1	1	± 0.6 %	± 0.6 %
Readout Electronics	0.3	Normal	1	1	1	± 0.3 %	± 0.3 %
Response Time	0.8	Rectangular	√3	1	1	± 0.5 %	± 0.5 %
Integration Time	2.6	Rectangular	√3	1	1	± 1.5 %	± 1.5 %
RF Ambient Noise	3.0	Rectangular	√3	1	1	± 1.7 %	± 1.7 %
RF Ambient Reflections	3.0	Rectangular	√3	1	1	± 1.7 %	± 1.7 %
Probe Positioner	0.8	Rectangular	√3	1	1	± 0.5 %	± 0.5 %
Probe Positioning	9.9	Rectangular	√3	1	1	± 5.7 %	± 5.7 %
Max. SAR Eval.	4.0	Rectangular	√3	1	1	± 2.3 %	± 2.3 %
<b>Test Sample Related</b>							
Device Positioning	2.9	Normal	1	1	1	± 2.9 %	± 2.9 %
Device Holder	3.6	Normal	1	1	1	± 3.6 %	± 3.6 %
Power Drift	5.0	Rectangular	√3	1	1	± 2.9 %	± 2.9 %
<b>Phantom and Setup</b>							
Phantom Uncertainty	4.0	Rectangular	√3	1	1	± 2.3 %	± 2.3 %
Liquid Conductivity (Target)	5.0	Rectangular	√3	0.64	0.43	± 1.8 %	± 1.2 %
Liquid Conductivity (Meas.)	2.5	Normal	1	0.64	0.43	± 1.6 %	± 1.1 %
Liquid Permittivity (Target)	5.0	Rectangular	√3	0.6	0.49	± 1.7 %	± 1.4 %
Liquid Permittivity (Meas.)	2.5	Normal	1	0.6	0.49	± 1.5 %	± 1.2 %
<b>Combined Standard Uncertainty</b>						± 12.8 %	± 12.6 %
<b>Coverage Factor for 95 %</b>						K=2	
<b>Expanded Uncertainty</b>						± 25.6 %	± 25.2 %

Table 12.3 Uncertainty Budget of DASYS for frequency range 3 GHz to 6 GHz



### **13. References**

- [1] FCC 47 CFR Part 2 “Frequency Allocations and Radio Treaty Matters; General Rules and Regulations”
- [2] ANSI/IEEE Std. C95.1-1992, “IEEE Standard for Safety Levels with Respect to Human Exposure to Radio Frequency Electromagnetic Fields, 3 kHz to 300 GHz”, September 1992
- [3] IEEE Std. 1528-2003, “Recommended Practice for Determining the Peak Spatial-Average Specific Absorption Rate (SAR) in the Human Head from Wireless Communications Devices: Measurement Techniques”, December 2003
- [4] FCC OET Bulletin 65 (Edition 97-01) Supplement C (Edition 01-01), “Evaluating Compliance with FCC Guidelines for Human Exposure to Radiofrequency Electromagnetic Fields”, June 2001
- [5] SPEAG DASY System Handbook
- [6] FCC KDB 248227 D01 v01r02, “SAR Measurement Procedures for 802.11 a/b/g Transmitters”, May 2007
- [7] FCC KDB 447498 D01 v04, “Mobile and Portable Device RF Exposure Procedures and Equipment Authorization Policies”, November 2009
- [8] FCC KDB 648474 D01 v01r05, “SAR Evaluation Considerations for Handsets with Multiple Transmitters and Antennas”, September 2008
- [9] FCC KDB 941225 D01 v02, “SAR Measurement Procedures for 3G Devices – CDMA 2000 / Ev-Do / WCDMA / HSDPA / HSPA”, October 2007
- [10] FCC KDB 941225 D03 v01, “Recommended SAR Test Reduction Procedures for GSM / GPRS / EDGE”, December 2008
- [11] FCC KDB 941225 D04 v01, “Evaluating SAR for GSM/(E)GPRS Dual Transfer Mode”, January 27 2010
- [12] FCC KDB 941225 D06 v01, “SAR Evaluation Procedures for Portable Devices with Wireless Router Capabilities”, April 2011



## ***Appendix A. Plots of System Performance Check***

The plots are shown as follows.



## ***Appendix B. Plots of SAR Measurement***

The plots are shown as follows.



## **Appendix C. DAS Y Calibration Certificate**

The DAS Y calibration certificates are shown as follows.