



# FCC TEST REPORT (PART 24)

**REPORT NO.:** RF120621C20-1 R1

**MODEL NO.:** PL83200

**FCC ID:** NM8PL83200

**RECEIVED:** Jun. 21, 2012

**TESTED:** Jul. 17 ~ Sep. 18, 2012

**ISSUED:** Sep. 19, 2012

**APPLICANT:** HTC Corporation

**ADDRESS:** 23, Xinghua Rd., Taoyuan 330, Taiwan, R.O.C.

**ISSUED BY:** Bureau Veritas Consumer Products Services  
(H.K.) Ltd., Taoyuan Branch

**LAB ADDRESS:** No. 47, 14th Ling, Chia Pau Vil., Lin Kou Dist., New  
Taipei City, Taiwan ( R.O.C. )

**TEST LOCATION:** No. 19, Hwa Ya 2nd Rd, Wen Hwa Tsuen, Kwei  
Shan Hsiang, Taoyuan Hsien 333, Taiwan, R.O.C.

This report should not be used by the client to claim product certification, approval, or endorsement by TAF or any government agencies.



This report is for your exclusive use. Any copying or replication of this report to or for any other person or entity, or use of our name or trademark, is permitted only with our prior written permission. This report sets forth our findings solely with respect to the test samples identified herein. The results set forth in this report are not indicative or representative of the quality or characteristics of the lot from which a test sample was taken or any similar or identical product unless specifically and expressly noted. Our report includes all of the tests requested by you and the results thereof based upon the information that you provided to us. You have 60 days from date of issuance of this report to notify us of any material error or omission caused by our negligence, provided, however, that such notice shall be in writing and shall specifically address the issue you wish to raise. A failure to raise such issue within the prescribed time shall constitute your unqualified acceptance of the completeness of this report, the tests conducted and the correctness of the report contents. Unless specific mention, the uncertainty of measurement has been explicitly taken into account to declare the compliance or non-compliance to the specification



## TABLE OF CONTENTS

|  |    |
|--|----|
| RELEASE CONTROL RECORD .....   | 3  |
| 1 CERTIFICATION .....  | 4  |
| 2 SUMMARY OF TEST RESULTS.....   | 5  |
| 2.1 MEASUREMENT UNCERTAINTY .....  | 5  |
| 2.2 TEST SITE AND INSTRUMENTS.....   | 6  |
| 3 GENERAL INFORMATION .....  | 7  |
| 3.1 GENERAL DESCRIPTION OF EUT .....   | 7  |
| 3.2 CONFIGURATION OF SYSTEM UNDER TEST .....   | 8  |
| 3.3 DESCRIPTION OF SUPPORT UNITS.....  | 9  |
| 3.4 TEST ITEM AND TEST CONFIGURATION .....   | 10 |
| 3.5 EUT OPERATING CONDITIONS.....  | 11 |
| 3.6 GENERAL DESCRIPTION OF APPLIED STANDARDS .....   | 11 |
| 4 TEST TYPES AND RESULTS.....  | 12 |
| 4.1 OUTPUT POWER MEASUREMENT .....   | 12 |
| 4.1.1 LIMITS OF OUTPUT POWER MEASUREMENT .....   | 12 |
| 4.1.2 TEST PROCEDURES .....  | 12 |
| 4.1.3 TEST SETUP .....   | 13 |
| 4.1.4 TEST RESULTS .....   | 14 |
| 4.2 FREQUENCY STABILITY MEASUREMENT .....  | 17 |
| 4.2.1 LIMITS OF FREQUENCY STABILITY MEASUREMENT .....                                      | 17 |
| 4.2.2 TEST PROCEDURE.....  | 17 |
| 4.2.3 TEST SETUP .....   | 17 |
| 4.2.4 TEST RESULTS .....   | 18 |
| 4.3 OCCUPIED BANDWIDTH MEASUREMENT .....   | 19 |
| 4.3.1 TEST PROCEDURES .....  | 19 |
| 4.3.2 TEST SETUP .....   | 19 |
| 4.3.3 TEST RESULTS .....   | 20 |
| 4.4 BAND EDGE MEASUREMENT .....  | 21 |
| 4.4.1 LIMITS OF BAND EDGE MEASUREMENT .....  | 21 |
| 4.4.2 TEST SETUP .....   | 21 |
| 4.4.3 TEST PROCEDURES .....  | 21 |
| 4.4.4 TEST RESULTS .....   | 22 |
| 4.5 CONDUCTED SPURIOUS EMISSIONS.....  | 24 |
| 4.5.1 LIMITS OF CONDUCTED SPURIOUS EMISSIONS MEASUREMENT .....                             | 24 |
| 4.5.2 TEST PROCEDURE.....  | 24 |
| 4.5.3 TEST SETUP .....   | 24 |
| 4.5.4 TEST RESULTS .....   | 25 |
| 4.6 RADIATED EMISSION MEASUREMENT .....  | 27 |
| 4.6.1 LIMITS OF RADIATED EMISSION MEASUREMENT .....  | 27 |
| 4.6.2 TEST PROCEDURES .....  | 27 |
| 4.6.3 DEVIATION FROM TEST STANDARD .....   | 27 |
| 4.6.4 TEST SETUP .....   | 28 |
| 4.6.5 TEST RESULTS .....   | 29 |
| 5 PHOTOGRAPHS OF THE TEST CONFIGURATION.....   | 39 |
| 6 INFORMATION ON THE TESTING LABORATORIES .....  | 40 |
| 7 APPENDIX A – MODIFICATIONS RECORDERS FOR ENGINEERING CHANGES TO THE EUT BY THE LAB ..... | 41 |



A D T

## RELEASE CONTROL RECORD

| ISSUE NO.        | REASON FOR CHANGE         | DATE ISSUED   |
|------------------|---------------------------|---------------|
| RF120621C20-1    | Original release          | Sep. 04, 2012 |
| RF120621C20-1 R1 | Add wireless charger mode | Sep. 19, 2012 |



# 1 CERTIFICATION

**PRODUCT:** Smartphone  
**MODEL:** PL83200  
**BRAND:** HTC  
**APPLICANT:** HTC Corporation  
**TESTED:** Jul. 17 ~ Sep. 18, 2012  
**TEST SAMPLE:** Production Unit  
**STANDARDS:** FCC Part 24, Subpart E

The above equipment (model: PL83200) has been tested by **Bureau Veritas Consumer Products Services (H.K.) Ltd., Taoyuan Branch**, and found compliance with the requirement of the above standards. The test record, data evaluation & Equipment Under Test (EUT) configurations represented herein are true and accurate accounts of the measurements of the sample's EMC characteristics under the conditions specified in this report.

**PREPARED BY** : Ivonne Wu , **DATE** : Sep. 19, 2012  
Ivonne Wu / Senior Specialist

**APPROVED BY** : Gary Chang , **DATE** : Sep. 19, 2012  
Gary Chang / Technical Manager



A D T

## 2 SUMMARY OF TEST RESULTS

The EUT has been tested according to the following specifications:

| APPLIED STANDARD: FCC Part 24 & Part 2 |   |        |  |
|--|---|--------|--|
| STANDARD SECTION                       | TEST TYPE                               | RESULT | REMARK   |
| 2.1046<br>24.232                       | Equivalent isotropically radiated power | PASS   | Meet the requirement of limit.   |
| 2.1055<br>24.235                       | Frequency Stability                     | PASS   | Meet the requirement of limit.   |
| 2.1049<br>24.238(b)                    | Occupied Bandwidth                      | PASS   | Meet the requirement of limit.   |
| 24.238(b)                              | Band Edge Measurements                  | PASS   | Meet the requirement of limit.   |
| 2.1051<br>24.238                       | Conducted Spurious Emissions            | PASS   | Meet the requirement of limit.   |
| 2.1053<br>24.238                       | Radiated Spurious Emissions             | PASS   | Meet the requirement of limit.<br>Minimum passing margin is -8.01dB at 39.18MHz. |

### 2.1 MEASUREMENT UNCERTAINTY

Where relevant, the following measurement uncertainty levels have been estimated for tests performed on the EUT as specified in CISPR 16-4-2:

| MEASUREMENT         | FREQUENCY       | UNCERTAINTY |
|---------------------|-----------------|-------------|
| Conducted emissions | 150kHz~30MHz    | 2.44 dB     |
| Radiated emissions  | 30MHz ~ 200MHz  | 2.93 dB     |
|                     | 200MHz ~1000MHz | 2.95 dB     |
|                     | 1GHz ~ 18GHz    | 2.26 dB     |
|                     | 18GHz ~ 40GHz   | 1.94 dB     |

This uncertainty represents an expanded uncertainty expressed at approximately the 95% confidence level using a coverage factor of k=2.



## 2.2 TEST SITE AND INSTRUMENTS

| DESCRIPTION & MANUFACTURER                     | MODEL NO.      | SERIAL NO. | DATE OF CALIBRATION | DUE DATE OF CALIBRATION |
|--|----------------|------------|---------------------|-------------------------|
| Test Receiver<br>Agilent                       | N9038A         | MY51210203 | Dec. 22, 2011       | Dec. 21, 2012           |
| Spectrum Analyzer<br>ROHDE & SCHWARZ           | FSU43          | 101261     | Dec. 21, 2011       | Dec. 20, 2012           |
| BILOG Antenna<br>SCHWARZBECK                   | VULB9168       | 9168-472   | Dec. 20, 2011       | Dec. 19, 2012           |
| HORN Antenna<br>SCHWARZBECK                    | BBHA 9120 D    | 9120D-969  | Dec. 20, 2011       | Dec. 19, 2012           |
| ORN Antenna<br>SCHWARZBECK                     | BBHA 9170      | 9170-480   | Dec. 20, 2011       | Dec. 19, 2012           |
| Preamplifier<br>EMCI                           | EMC 012645     | 980115     | Dec. 30, 2011       | Dec. 29, 2012           |
| Preamplifier<br>EMCI                           | EMC 330H       | 980112     | Dec. 30, 2011       | Dec. 29, 2012           |
| RF signal cable<br>HUBER+SUHNNER               | SUCOFLEX 104   | 309219/4   | Oct. 21, 2011       | Oct. 20, 2012           |
| RF signal cable<br>HUBER+SUHNNER               | SUCOFLEX 104   | 250130/4   | Jan. 02, 2012       | Jan. 01, 2013           |
| RF signal cable<br>Worken                      | RG-213         | NA         | Jan. 02, 2012       | Jan. 01, 2013           |
| Software                                       | E3<br>6.120103 | NA         | NA                  | NA                      |
| Antenna Tower<br>MF                            | MFA-440H       | NA         | NA                  | NA                      |
| Turn Table<br>MF                               | MFT-201SS      | NA         | NA                  | NA                      |
| Antenna Tower & Turn Table<br>Controller<br>MF | MF-7802        | NA         | NA                  | NA                      |
| Mini-Circuits Power Splitter                   | ZN2PD-9G       | NA         | Mar. 23, 2012       | Mar. 22, 2013           |
| JFW 20dB attenuation                           | 50HF-020-SMA   | NA         | NA                  | NA                      |
| Communications<br>Tester-Wireless              | E5515C         | MY50266653 | Sep. 28, 2011       | Sep. 27, 2012           |
| Radio Communication<br>Analyzer                | MT8820C        | 6201127458 | May 25, 2012        | May 24, 2013            |

**NOTE:** 1. The calibration interval of the above test instruments is 12 months and the calibrations are traceable to NML/ROC and NIST/USA.

2. The test was performed in HwaYa Chamber 9.
3. The horn antenna and HP preamplifier (model: 8449B) are used only for the measurement of emission frequency above 1GHz if tested.
4. The FCC Site Registration No. is 460141.
5. The IC Site Registration No. is IC 7450F-4.



A D T

### 3 GENERAL INFORMATION

#### 3.1 GENERAL DESCRIPTION OF EUT

|                              |  |  |
|------------------------------|--|--|
| <b>EUT</b>                   | Smartphone   |  |
| <b>MODEL NO.</b>             | PL83200  |  |
| <b>POWER SUPPLY</b>          | 5.0Vdc (adapter or host equipment)<br>3.8Vdc (battery) |  |
| <b>MODULATION TYPE</b>       | <b>GSM/GPRS</b>  | GMSK                                   |
|                              | <b>EDGE</b>  | 8PSK                                   |
|                              | <b>WCDMA</b>   | BPSK                                   |
|                              | <b>CDMA</b>  | QPSK, OQPSK, HPSK                      |
| <b>FREQUENCY RANGE</b>       | <b>GSM/GPRS/EDGE</b>                                   | 1850.2MHz ~ 1909.8MHz                  |
|                              | <b>WCDMA</b>   | 1852.4MHz ~ 1907.6MHz                  |
|                              | <b>CDMA</b>  | 1851.3MHz ~ 1908.8MHz                  |
| <b>MAX. EIRP POWER</b>       | <b>GSM</b>   | 580.76mW                               |
|                              | <b>EDGE</b>  | 230.67mW                               |
|                              | <b>WCDMA</b>   | 124.45mW                               |
|                              | <b>CDMA</b>  | 137.40mW                               |
| <b>EMISSION DESIGNATOR</b>   | <b>GSM</b>   | 248KGXW                                |
|                              | <b>EDGE</b>  | 244KG7W                                |
|                              | <b>WCDMA</b>   | 4M17F9W                                |
|                              | <b>CDMA</b>  | 1M28F9W                                |
| <b>MULTI-SLOTS CLASS</b>     | 12   |  |
| <b>WCDMA RELEASE VERSION</b> | 6  |  |
| <b>ANTENNA TYPE</b>          | <b>GSM</b>   | Fixed Internal antenna with -2dBi gain |
|                              | <b>EDGE</b>  |  |
|                              | <b>WCDMA</b>   |  |
|                              | <b>CDMA</b>  |  |
| <b>I/O PORTS</b>             | Refer to users' manual                                 |  |
| <b>DATA CABLE</b>            | Refer to NOTE as below                                 |  |
| <b>ACCESSORY DEVICES</b>     | Refer to NOTE as below                                 |  |

**NOTE:**

- The EUT's accessories list refers to Ext Pho.pdf.  
\* Item 2, 3, 5, 6, 7, 8 were the worst for the final test.
- The above EUT information was declared by manufacturer and for more detailed features description, please refer to the manufacturer's specifications or User's Manual.

### 3.2 CONFIGURATION OF SYSTEM UNDER TEST

#### FOR RADIATION EMISSION TEST

##### Tset Mode A

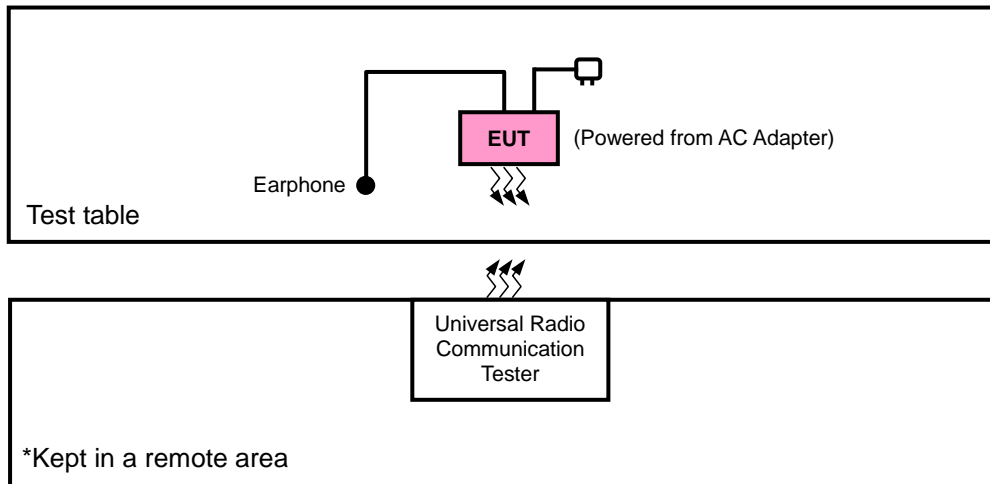

##### Tset Mode B

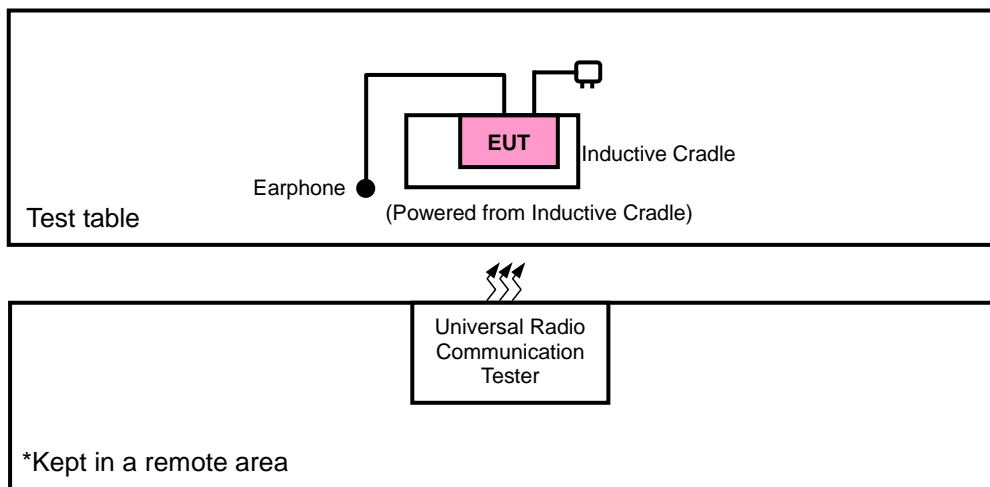





A D T

## FOR E.I.R.P. TEST

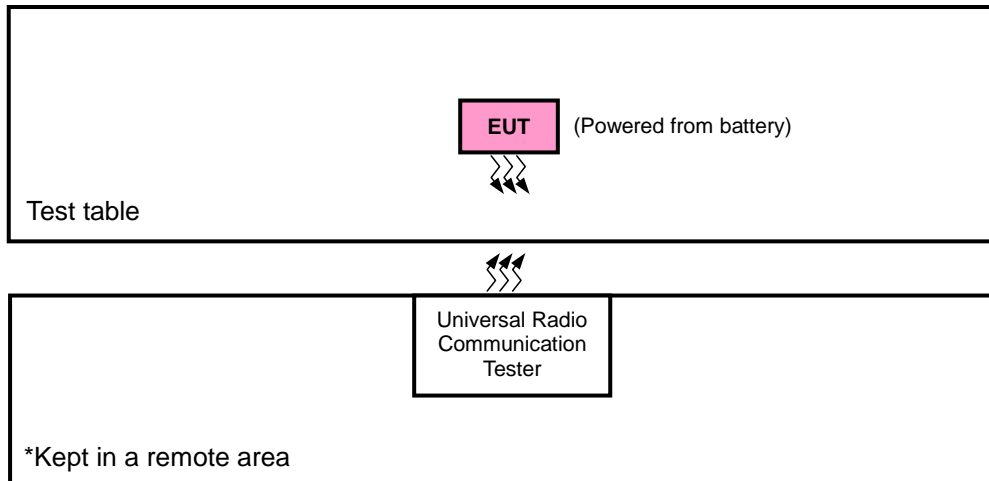

### 3.3 DESCRIPTION OF SUPPORT UNITS

The EUT has been tested as an independent unit together with other necessary accessories or support units. The following support units or accessories were used to form a representative test configuration during the tests.

| NO. | PRODUCT          | BRAND     | MODEL NO. | SERIAL NO. | FCC ID |
|-----|------------------|-----------|-----------|------------|--------|
| 1   | Earphone         | Merry     | HS S250   | NA         | NA     |
| 2   | Inductive Cradle | Energizer | IC2B      | NA         | NA     |

| NO. | SIGNAL CABLE DESCRIPTION OF THE ABOVE SUPPORT UNITS |
|-----|---|
| 1   | 1m non-shielded cable without core                  |
| 2   | NA  |

#### NOTE:

1. All power cords of the above support units are non shielded (1.8m).
2. Items 1-2 were provided by client.



A D T

### 3.4 TEST ITEM AND TEST CONFIGURATION

Pre-Scan has been conducted to determine the worst-case mode from all possible combinations between available modulations, data rates, XYZ axis and antenna ports. The worst case was found when positioned on X-plane for EIRP and X-axis for radiated emission. Following channel(s) was (were) selected for the final test as listed below:

| EUT CONFIGURE MODE | DESCRIPTION     |
|--------------------|-----------------|
| A                  | Normal Link     |
| B                  | Wireless Charge |

#### GSM MODE

| EUT CONFIGURE MODE | TEST ITEM           | AVAILABLE CHANNEL | TESTED CHANNEL | MODE      |
|--------------------|---------------------|-------------------|----------------|-----------|
| A                  | EIRP                | 512 to 810        | 512, 661, 810  | GSM, EDGE |
| A                  | FREQUENCY STABILITY | 512 to 810        | 661            | GSM, EDGE |
| A                  | OCCUPIED BANDWIDTH  | 512 to 810        | 512, 661, 810  | GSM, EDGE |
| A                  | BAND EDGE           | 512 to 810        | 512, 810       | GSM, EDGE |
| A                  | CONDCUDED EMISSION  | 512 to 810        | 661            | GSM       |
| A                  | RADIATED EMISSION   | 512 to 810        | 661            | GSM, EDGE |
| B                  | RADIATED EMISSION   | 512 to 810        | 661            | GSM       |

#### WCDMA MODE

| EUT CONFIGURE MODE | TEST ITEM           | AVAILABLE CHANNEL | TESTED CHANNEL   | MODE  |
|--------------------|---------------------|-------------------|------------------|-------|
| A                  | EIRP                | 9262 to 9538      | 9262, 9400, 9538 | WCDMA |
| A                  | FREQUENCY STABILITY | 9262 to 9538      | 9400             | WCDMA |
| A                  | OCCUPIED BANDWIDTH  | 9262 to 9538      | 9262, 9400, 9538 | WCDMA |
| A                  | BAND EDGE           | 9262 to 9538      | 9262, 9538       | WCDMA |
| A                  | CONDCUDED EMISSION  | 9262 to 9538      | 9400             | WCDMA |
| A                  | RADIATED EMISSION   | 9262 to 9538      | 9400             | WCDMA |



## CDMA MODE

| EUT CONFIGURE MODE | TEST ITEM           | AVAILABLE CHANNEL | TESTED CHANNEL | MODE  |
|--------------------|---------------------|-------------------|----------------|-------|
| A                  | EIRP                | 25 to 1175        | 25, 600, 1175  | 1xRTT |
| A                  | FREQUENCY STABILITY | 25 to 1175        | 600            | 1xRTT |
| A                  | OCCUPIED BANDWIDTH  | 25 to 1175        | 25, 600, 1175  | 1xRTT |
| A                  | BAND EDGE           | 25 to 1175        | 25, 1175       | 1xRTT |
| A                  | CONDCUDED EMISSION  | 25 to 1175        | 600            | 1xRTT |
| A                  | RADIATED EMISSION   | 25 to 1175        | 600            | 1xRTT |

### TEST CONDITION:

| TEST ITEM           | ENVIRONMENTAL CONDITIONS | INPUT POWER  | TESTED BY    |
|---------------------|--------------------------|--------------|--------------|
| EIRP                | 26deg. C, 58%RH          | 3.8Vdc       | Phoenix Chen |
| FREQUENCY STABILITY | 26deg. C, 58%RH          | 3.8Vdc       | Phoenix Chen |
| OCCUPIED BANDWIDTH  | 26deg. C, 58%RH          | 3.8Vdc       | Phoenix Chen |
| BAND EDGE           | 26deg. C, 58%RH          | 3.8Vdc       | Phoenix Chen |
| CONDCUDED EMISSION  | 26deg. C, 58%RH          | 3.8Vdc       | Phoenix Chen |
| RADIATED EMISSION   | 25deg. C, 65%RH          | 120Vac, 60Hz | Kay Wu       |

### 3.5 EUT OPERATING CONDITIONS

The EUT makes a call to the communication simulator. The communication simulator station system controlled a EUT to export maximum output power under transmission mode and specific channel frequency

### 3.6 GENERAL DESCRIPTION OF APPLIED STANDARDS

The EUT is a RF product. According to the specifications of the manufacturer, it must comply with the requirements of the following standards:

**FCC 47 CFR Part 2**

**FCC 47 CFR Part 24**

**ANSI/TIA/EIA-603-C 2004**

**NOTE:** All test items have been performed and recorded as per the above standards.

## 4 TEST TYPES AND RESULTS

### 4.1 OUTPUT POWER MEASUREMENT

#### 4.1.1 LIMITS OF OUTPUT POWER MEASUREMENT

Mobile and portable stations are limited to 2 watts EIRP

#### 4.1.2 TEST PROCEDURES

##### **EIRP MEASUREMENT:**

- a. All measurements were done at low, middle and high operational frequency range. RBW and VBW is 1MHz for GSM, GPRS & EDGE, 5MHz for WCDMA and CDMA mode.
- b. Substitution method is used for E.I.R.P measurement. In the semi-anechoic chamber, EUT placed on the 0.8m height of Turn Table, rotated the table around 360 degrees to search the maximum radiation power and receiver antenna shall be rotated vertical and horizontal polarization and moved height from 1m to 4m to find the maximum polar radiated power. The “Read Value” is the spectrum reading the maximum power value.
- c. The substitution horn antenna is substituted for EUT at the same position and signals generator export the CW signal to the substitution antenna via a tx cable. Rotated the Turn Table and moved receiving antenna to find the maximum radiation power. Adjust output power level of S.G to get a Value of spectrum reading equal to “Read Value” of step b. Record the power level of S.G
- d.  $EIRP = \text{Output power level of S.G} - \text{TX cable loss} + \text{Antenna gain of substitution horn.}$

##### **CONDUCTED POWER MEASUREMENT:**

The EUT was set up for the maximum power with GSM, GPRS, EDGE, WCDMA & CDMA link data modulation and link up with simulator. Set the EUT to transmit under low, middle and high channel and record the power level shown on simulator.

### 4.1.3 TEST SETUP

#### EIRP MEASUREMENT:

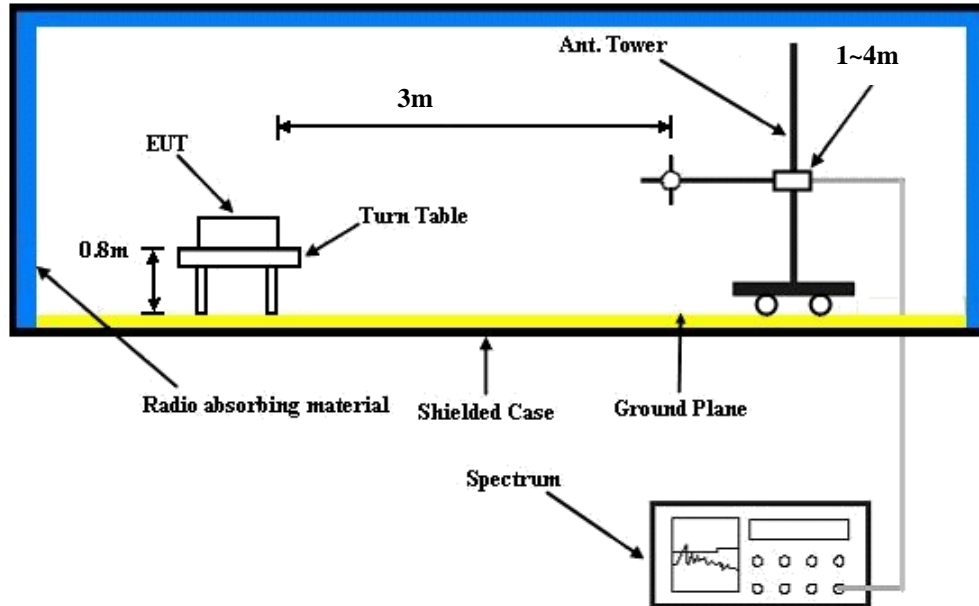

For the actual test configuration, please refer to the attached file (Test Setup Photo).

#### CONDUCTED POWER MEASUREMENT:

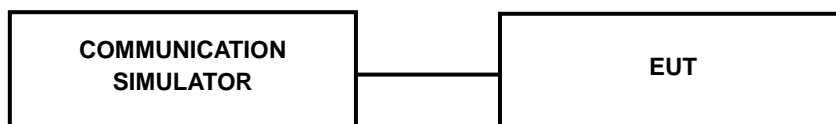

For the actual test configuration, please refer to the attached file (Test Setup Photo).



A D T

#### 4.1.4 TEST RESULTS

##### CONDUCTED OUTPUT POWER (dBm)

| Band                     | GSM1900 |        |        |
|--------------------------|---------|--------|--------|
| Channel                  | 512     | 661    | 810    |
| Frequency (MHz)          | 1850.2  | 1880.0 | 1909.8 |
| GSM (1 Uplink)           | 30.65   | 30.70  | 30.47  |
| GPRS 8 (GMSK, 1 slot)    | 30.64   | 30.69  | 30.46  |
| GPRS 10 (GMSK, 2 slot)   | 30.00   | 30.05  | 29.82  |
| GPRS 11 (GMSK, 3 Uplink) | 29.25   | 29.30  | 29.06  |
| GPRS 12 (GMSK, 4 Uplink) | 27.95   | 28.00  | 27.77  |
| EDGE 8 (GMSK, 1 Uplink)  | 30.45   | 30.50  | 30.27  |
| EDGE 10 (GMSK, 2 Uplink) | 29.67   | 29.72  | 29.49  |
| EDGE 11 (GMSK, 3 Uplink) | 29.24   | 29.29  | 29.06  |
| EDGE 12 (GMSK, 4 Uplink) | 27.80   | 27.85  | 27.62  |
| EDGE 8 (8PSK, 1 Uplink)  | 26.07   | 26.12  | 25.89  |
| EDGE 10 (8PSK, 2 Uplink) | 25.84   | 25.89  | 25.66  |
| EDGE 11 (8PSK, 3 Uplink) | 25.13   | 25.18  | 24.95  |
| EDGE 12 (8PSK, 4 Uplink) | 23.95   | 24.00  | 23.77  |

| Band            | WCDMA II |        |        |
|-----------------|----------|--------|--------|
| Channel         | 9262     | 9400   | 9538   |
| Frequency (MHz) | 1852.4   | 1880.0 | 1907.6 |
| RMC 12.2K       | 23.78    | 24.14  | 23.73  |
| HSDPA Subtest-1 | 22.31    | 22.67  | 22.26  |
| HSDPA Subtest-2 | 22.26    | 22.62  | 22.21  |
| HSDPA Subtest-3 | 22.32    | 22.68  | 22.27  |
| HSDPA Subtest-4 | 22.33    | 22.69  | 22.28  |
| HSUPA Subtest-1 | 22.25    | 22.61  | 22.20  |
| HSUPA Subtest-2 | 20.77    | 21.13  | 20.72  |
| HSUPA Subtest-3 | 21.50    | 21.86  | 21.45  |
| HSUPA Subtest-4 | 22.07    | 22.43  | 22.02  |
| HSUPA Subtest-5 | 22.97    | 23.33  | 22.92  |

| Band              | CDMA    |       |         |
|-------------------|---------|-------|---------|
| Channel           | 25      | 600   | 1175    |
| Frequency (MHz)   | 1851.25 | 1880  | 1908.75 |
| RC1+SO55          | 24.57   | 24.52 | 24.34   |
| RC3+SO55          | 24.60   | 24.55 | 24.37   |
| RC3+SO32(+ F-SCH) | 24.58   | 24.53 | 24.35   |
| RC3+SO32(+SCH)    | 24.54   | 24.49 | 24.31   |
| RTAP 153.6        | 24.50   | 24.45 | 24.32   |
| RETAP 4096        | 24.45   | 24.40 | 24.27   |



A D T

## EIRP POWER (dBm)

### GSM

| Plane | Channel | Frequency (MHz) | LVL (dBm) | Correction Factor(dB) | EIRP(dBm) | EIRP(mW) | Polarization (H/V) |
|-------|---------|-----------------|-----------|-----------------------|-----------|----------|--------------------|
| Y     | 512     | 1850.2          | -10.55    | 38.19                 | 27.64     | 580.76   | H                  |
|       | 661     | 1880.0          | -11.41    | 38.70                 | 27.29     | 535.80   | H                  |
|       | 810     | 1909.8          | -12.22    | 39.35                 | 27.13     | 516.42   | H                  |
|       | 512     | 1850.2          | -15.21    | 38.48                 | 23.27     | 212.32   | V                  |
|       | 661     | 1880.0          | -14.74    | 38.59                 | 23.85     | 242.66   | V                  |
|       | 810     | 1909.8          | -15.00    | 38.87                 | 23.87     | 243.78   | V                  |

### EDGE

| Plane | Channel | Frequency (MHz) | LVL (dBm) | Correction Factor(dB) | EIRP(dBm) | EIRP(mW) | Polarization (H/V) |
|-------|---------|-----------------|-----------|-----------------------|-----------|----------|--------------------|
| Y     | 512     | 1850.2          | -14.72    | 38.19                 | 23.47     | 222.33   | H                  |
|       | 661     | 1880.0          | -15.55    | 38.70                 | 23.15     | 206.54   | H                  |
|       | 810     | 1909.8          | -15.72    | 39.35                 | 23.63     | 230.67   | H                  |
|       | 512     | 1850.2          | -19.07    | 38.48                 | 19.41     | 87.30    | V                  |
|       | 661     | 1880.0          | -18.82    | 38.59                 | 19.77     | 94.84    | V                  |
|       | 810     | 1909.8          | -19.02    | 38.87                 | 19.85     | 96.61    | V                  |

### WCDMA

| Plane | Channel | Frequency (MHz) | LVL (dBm) | Correction Factor(dB) | EIRP(dBm) | EIRP(mW) | Polarization (H/V) |
|-------|---------|-----------------|-----------|-----------------------|-----------|----------|--------------------|
| Y     | 9262    | 1852.4          | -17.24    | 38.19                 | 20.95     | 124.45   | H                  |
|       | 9400    | 1880.0          | -18.28    | 38.70                 | 20.42     | 110.15   | H                  |
|       | 9538    | 1907.6          | -18.68    | 39.35                 | 20.67     | 116.68   | H                  |
|       | 9262    | 1852.4          | -22.59    | 38.48                 | 15.89     | 38.82    | V                  |
|       | 9400    | 1880.0          | -23.05    | 38.59                 | 15.54     | 35.81    | V                  |
|       | 9538    | 1907.6          | -23.82    | 38.87                 | 15.05     | 31.99    | V                  |



A D T

## CDMA

| Plane | Channel | Frequency (MHz) | LVL (dBm) | Correction Factor(dB) | EIRP(dBm) | EIRP(mW) | Polarization (H/V) |
|-------|---------|-----------------|-----------|-----------------------|-----------|----------|--------------------|
| Y     | 25      | 1851.3          | -16.89    | 38.19                 | 21.30     | 134.90   | H                  |
|       | 600     | 1880.0          | -17.32    | 38.70                 | 21.38     | 137.40   | H                  |
|       | 1175    | 1908.8          | -18.23    | 39.35                 | 21.12     | 129.42   | H                  |
|       | 25      | 1851.3          | -22.36    | 38.48                 | 16.12     | 40.93    | V                  |
|       | 600     | 1880.0          | -21.73    | 38.59                 | 16.86     | 48.53    | V                  |
|       | 1175    | 1908.8          | -22.09    | 38.87                 | 16.78     | 47.64    | V                  |



## 4.2 FREQUENCY STABILITY MEASUREMENT

### 4.2.1 LIMITS OF FREQUENCY STABILITY MEASUREMENT

The frequency stability shall be sufficient to ensure that the fundamental emission stays within the authorized frequency block.

### 4.2.2 TEST PROCEDURE

- a. Device is placed at the oven room. The oven room could control the temperatures and humidity. Power warm up is at least 15 min and power applied should perform before recording frequency error.
- b. EUT is connected the external power supply to control the DC input power. The test voltage range is from minimum to maximum working voltage. Each step shall be record the frequency error rate.
- c. The temperature range step is 10 degrees in this test items. All temperature levels shall be hold the  $\pm 0.5^{\circ}\text{C}$  during the measurement testing. The each temperature step shall be at least 0.5 hours, consider the EUT could be test under the stability condition.

**NOTE:** The frequency error was recorded frequency error from the communication simulator.

### 4.2.3 TEST SETUP

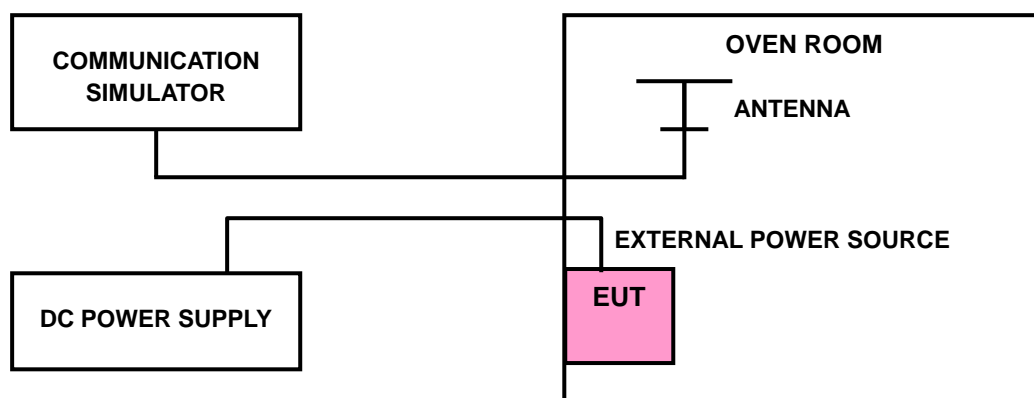

#### 4.2.4 TEST RESULTS

##### FREQUENCY ERROR VS. VOLTAGE

| VOLTAGE (Volts) | FREQUENCY ERROR (ppm) |        |        |       | LIMIT (ppm) |
|-----------------|-----------------------|--------|--------|-------|-------------|
|                 | GPRS                  | EDGE   | WCDMA  | CDMA  |             |
| 3.8             | -0.018                | -0.018 | -0.007 | 0.004 | 2.5         |
| 3.6             | -0.020                | -0.015 | -0.008 | 0.004 | 2.5         |
| 4.35            | 0.019                 | -0.016 | -0.007 | 0.004 | 2.5         |

**NOTE:** The applicant defined the normal working voltage of the battery is from 3.6Vdc to 4.35Vdc.

##### FREQUENCY ERROR vs. TEMPERATURE.

| TEMP. (°C) | FREQUENCY ERROR (ppm) |        |        |       | LIMIT (ppm) |
|------------|-----------------------|--------|--------|-------|-------------|
|            | GPRS                  | EDGE   | WCDMA  | CDMA  |             |
| -30        | -0.021                | -0.026 | -0.008 | 0.006 | 2.5         |
| -20        | -0.022                | -0.025 | -0.007 | 0.006 | 2.5         |
| -10        | -0.021                | -0.026 | -0.008 | 0.005 | 2.5         |
| 0          | -0.020                | -0.022 | -0.007 | 0.005 | 2.5         |
| 10         | -0.019                | -0.027 | -0.007 | 0.007 | 2.5         |
| 20         | -0.022                | -0.021 | -0.008 | 0.003 | 2.5         |
| 30         | -0.020                | -0.021 | -0.007 | 0.004 | 2.5         |
| 40         | -0.018                | -0.023 | -0.007 | 0.004 | 2.5         |
| 50         | -0.018                | -0.024 | -0.008 | 0.004 | 2.5         |
| 60         | -0.019                | -0.017 | 0.007  | 0.004 | 2.5         |

### 4.3 OCCUPIED BANDWIDTH MEASUREMENT

#### 4.3.1 TEST PROCEDURES

The EUT makes a call to the communication simulator. All measurements were done at low, middle and high operational frequency range. The communication simulator station system controlled a EUT to export maximum output power under transmission mode and specific channel frequency. Use OBW measurement function of Spectrum analyzer to measure 99 % occupied bandwidth.

#### 4.3.2 TEST SETUP

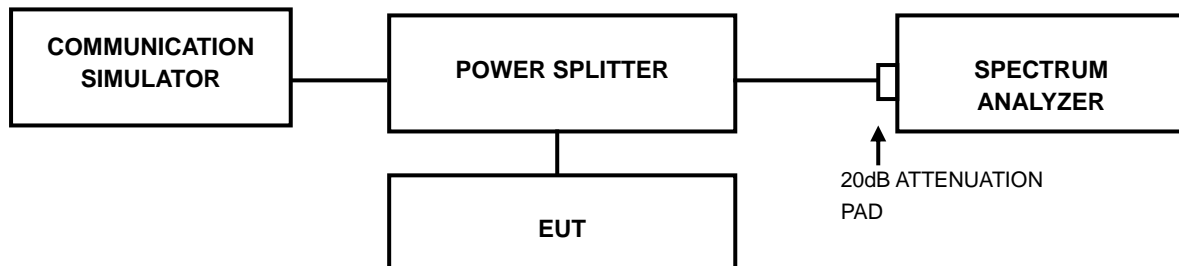



A D T

### 4.3.3 TEST RESULTS

| CHANNEL | FREQUENCY (MHz) | 99% OCCUPIED BANDWIDTH (kHz) |        | CHANNEL | FREQUENCY (MHz) | 99% OCCUPIED BANDWIDTH (MHz) |
|---------|-----------------|------------------------------|--------|---------|-----------------|------------------------------|
|         |                 | GSM                          | EDGE   |         |                 | WCDMA                        |
| 512     | 1850.2          | 248.00                       | 242.00 | 9262    | 1852.4          | 4.17                         |
| 661     | 1880.0          | 246.00                       | 244.00 | 9400    | 1880.0          | 4.15                         |
| 810     | 1909.8          | 246.00                       | 244.00 | 9538    | 1907.6          | 4.17                         |

| CHANNEL | FREQUENCY (MHz) | 99% OCCUPIED BANDWIDTH (MHz) |
|---------|-----------------|------------------------------|
|         |                 | CDMA                         |
| 25      | 1851.3          | 1.275                        |
| 600     | 1880.0          | 1.275                        |
| 1175    | 1908.8          | 1.274                        |

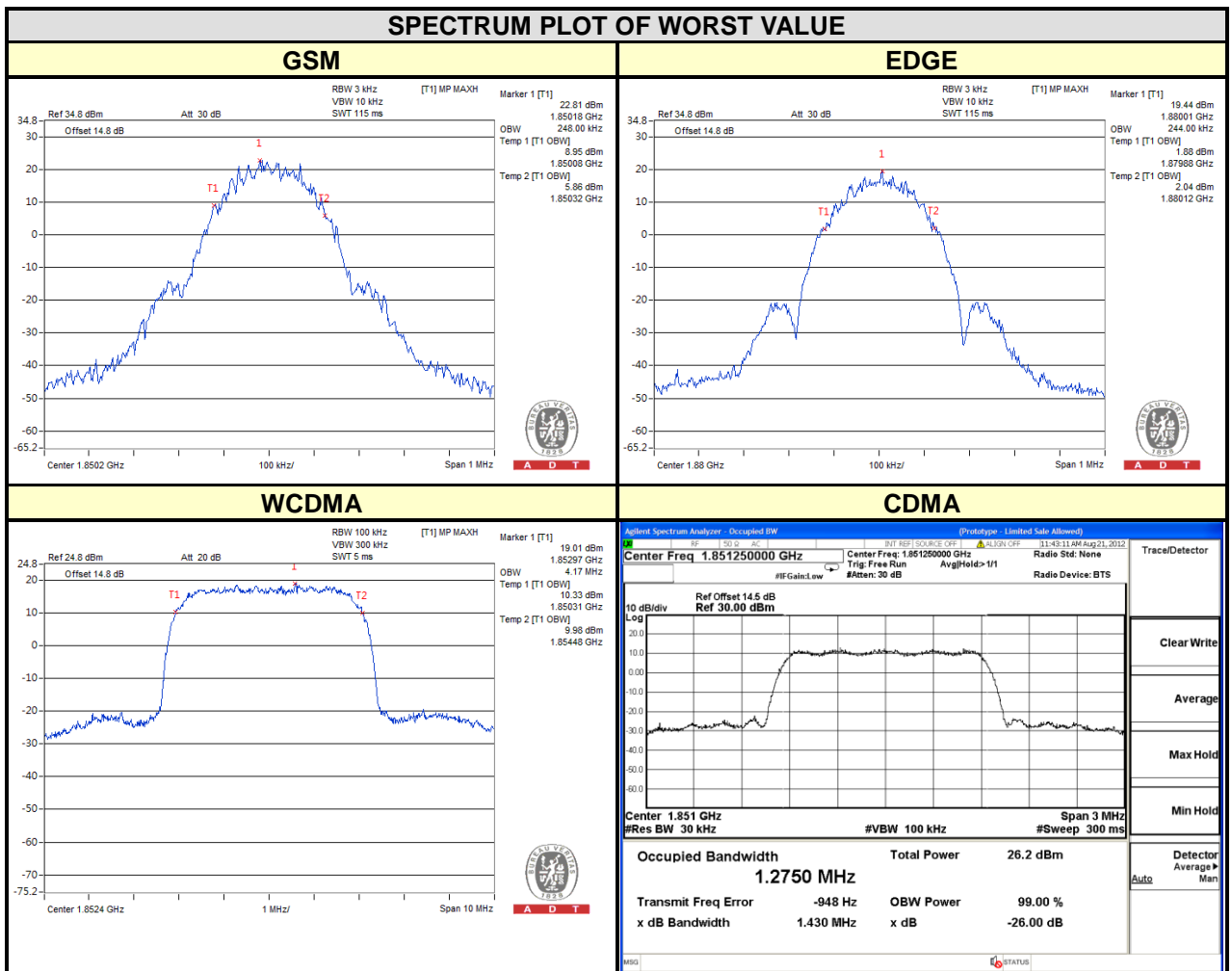

## 4.4 BAND EDGE MEASUREMENT

### 4.4.1 LIMITS OF BAND EDGE MEASUREMENT

Power of any emission outside of the authorized operating frequency ranges must be attenuated below the transmitting power (P) by a factor of at least  $43 + 10 \log(P)$  dB. In the 1 MHz bands immediately outside and adjacent to the frequency block a resolution bandwidth of at least one percent of the emission bandwidth of the fundamental emission of the transmitter may be employed.

### 4.4.2 TEST SETUP

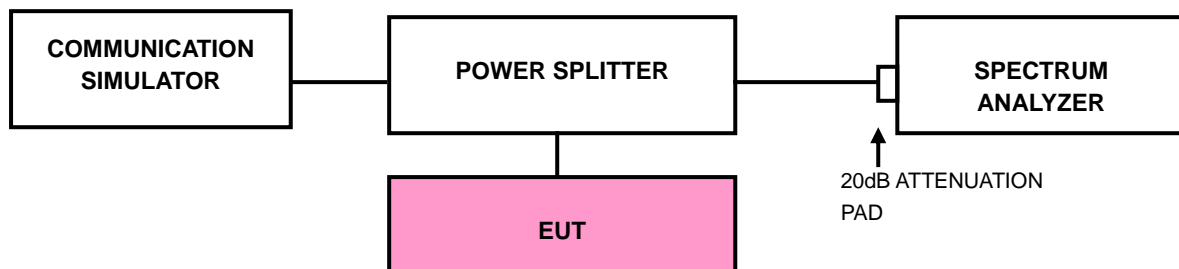

### 4.4.3 TEST PROCEDURES

- All measurements were done at low and high operational frequency range.
- The center frequency of spectrum is the band edge frequency and span is 1 MHz. RB of the spectrum is 3kHz and VB of the spectrum is 10kHz (GSM/GPRS/ EDGE).
- The center frequency of spectrum is the band edge frequency and span is 5MHz. RB of the spectrum is 100kHz and VB of the spectrum is 300kHz (WCDMA).
- The center frequency of spectrum is the band edge frequency and span is 2MHz. RB of the spectrum is 13kHz and VB of the spectrum is 51kHz (CDMA).
- Record the max trace plot into the test report.



A D T

### 4.4.4 TEST RESULTS

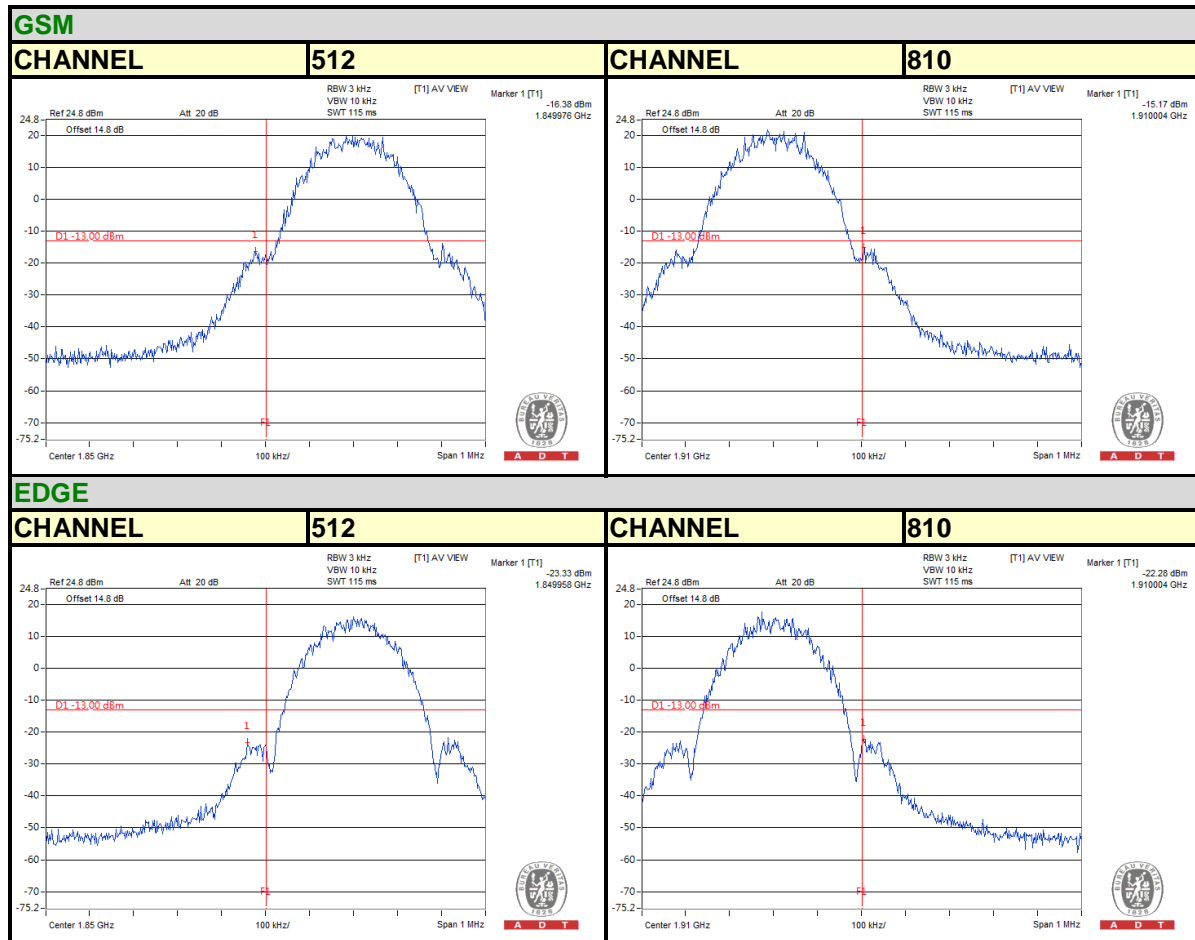



A D T

### WCDMA

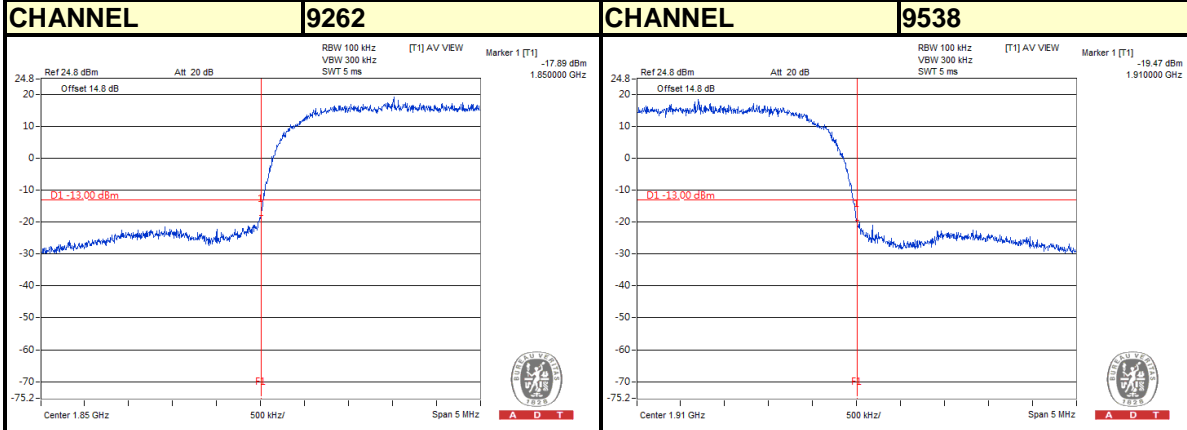

### CDMA

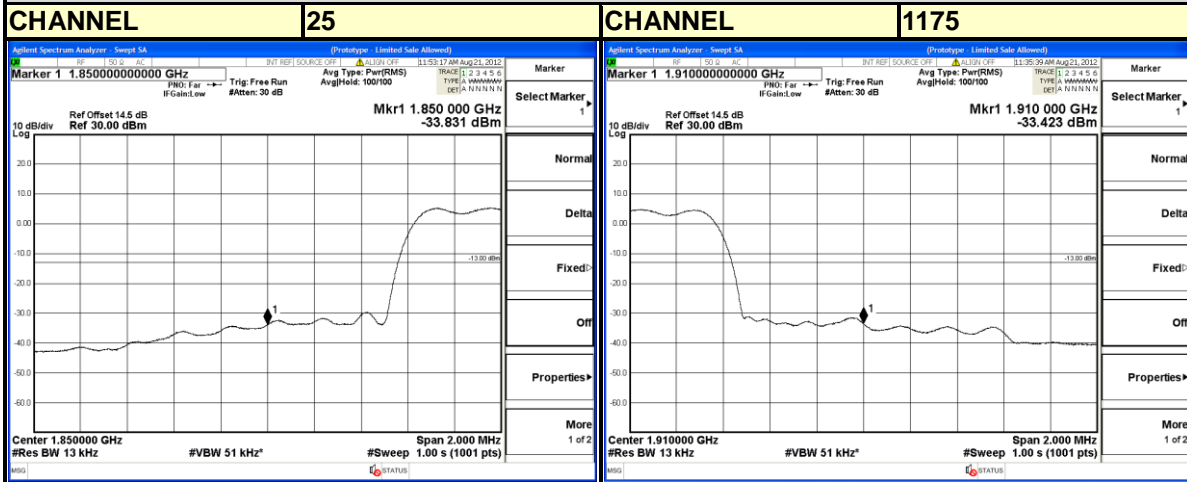

## 4.5 CONDUCTED SPURIOUS EMISSIONS

### 4.5.1 LIMITS OF CONDUCTED SPURIOUS EMISSIONS MEASUREMENT

The power of any emission outside of the authorized operating frequency ranges must be attenuated below the transmitting power (P) by a factor of at least  $43 + 10 \log(P)$  dB. The emission limit equal to  $-13\text{dBm}$ .

### 4.5.2 TEST PROCEDURE

- a. The EUT makes a phone call to the communication simulator. All measurements were done at low, middle and high operational frequency range.
- b. Measuring frequency range is from 30 MHz to 19.1GHz. 10dB attenuation pad is connected with spectrum. RBW=1MHz and VBW=3MHz is used for conducted emission measurement.

### 4.5.3 TEST SETUP

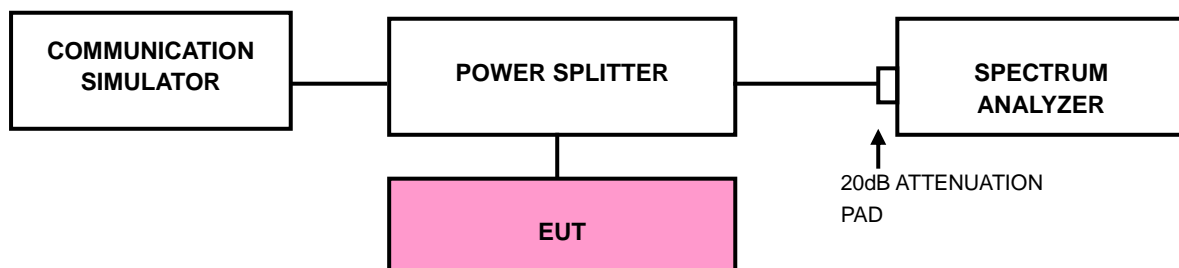





A D T

### 4.5.4 TEST RESULTS

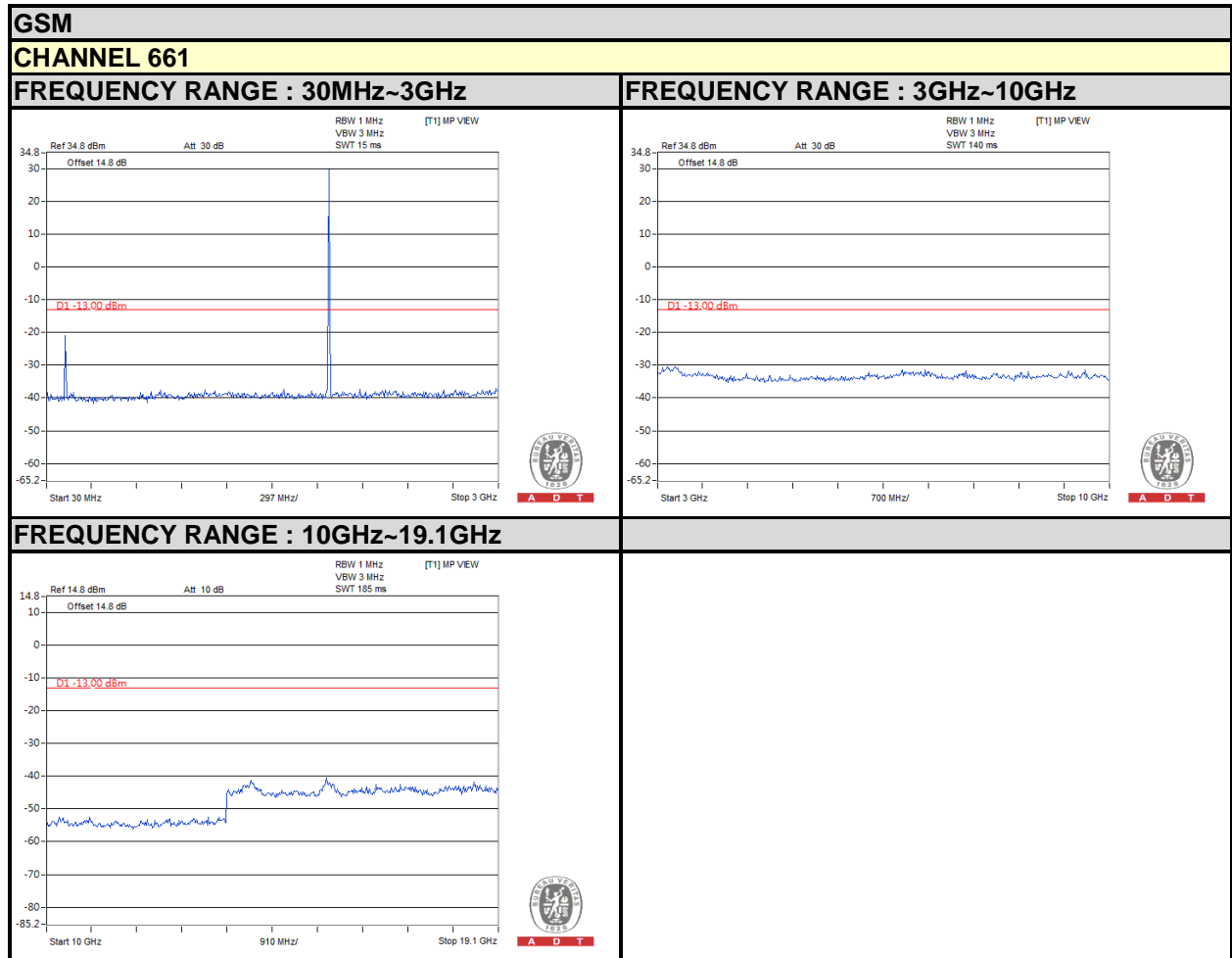



A D T

### WCDMA

#### CHANNEL 9400

##### FREQUENCY RANGE : 30MHz~3GHz

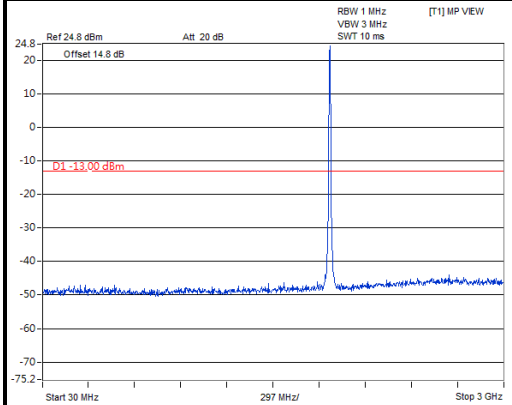

##### FREQUENCY RANGE : 3GHz~10GHz

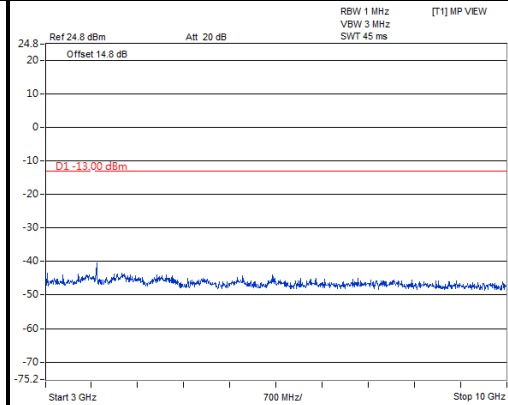

##### FREQUENCY RANGE : 10GHz~19.1GHz

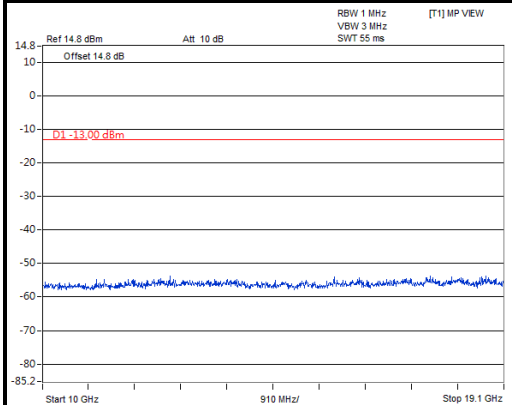

### CDMA

#### CHANNEL 600

##### FREQUENCY RANGE : 30MHz~19.1GHz

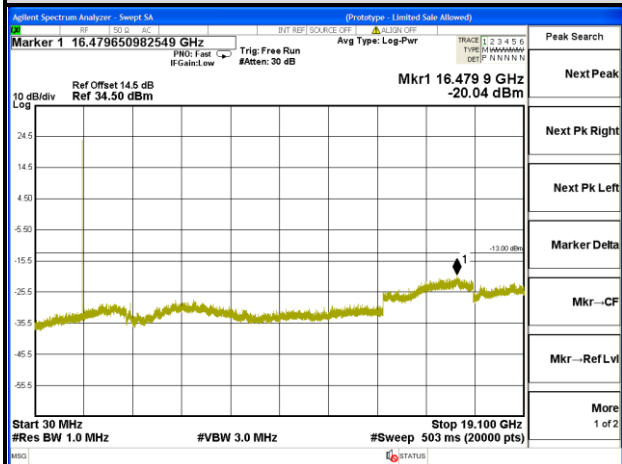

## 4.6 RADIATED EMISSION MEASUREMENT

### 4.6.1 LIMITS OF RADIATED EMISSION MEASUREMENT

The power of any emission outside of the authorized operating frequency ranges must be attenuated below the transmitting power (P) by a factor of at least  $43 + 10 \log(P)$  dB. The emission limit equal to  $-13\text{dBm}$ .

### 4.6.2 TEST PROCEDURES

- a. Substitution method is used for E.I.R.P measurement. In the semi-anechoic chamber, EUT placed on the 0.8m height of Turn Table, rotated the table around 360 degrees to search the maximum radiation power and receiver antenna shall be rotated vertical and horizontal polarization and moved height from 1m to 4m to find the maximum polar radiated power. The "Read Value" is the spectrum reading the maximum power value.
- b. The substitution horn antenna is substituted for EUT at the same position and signals generator export the CW signal to the substitution antenna via a TX cable. Rotated the Turn Table and moved receiving antenna to find the maximum radiation power. Adjust output power level of S.G to get a Value of spectrum reading equal to "Read Value" of step a. Record the power level of S.G
- c.  $\text{EIRP} = \text{Output power level of S.G} - \text{TX cable loss} + \text{Antenna gain of substitution horn}$ .
- d. E.R.P power can be calculated form E.I.R.P power by subtracting the gain of dipole,  
 $\text{E.R.P power} = \text{E.I.P.R power} - 2.15\text{dBi}$ .

**NOTE:** The resolution bandwidth and video bandwidth of test receiver/spectrum analyzer is 1MHz/3MHz.

### 4.6.3 DEVIATION FROM TEST STANDARD

No deviation

#### 4.6.4 TEST SETUP

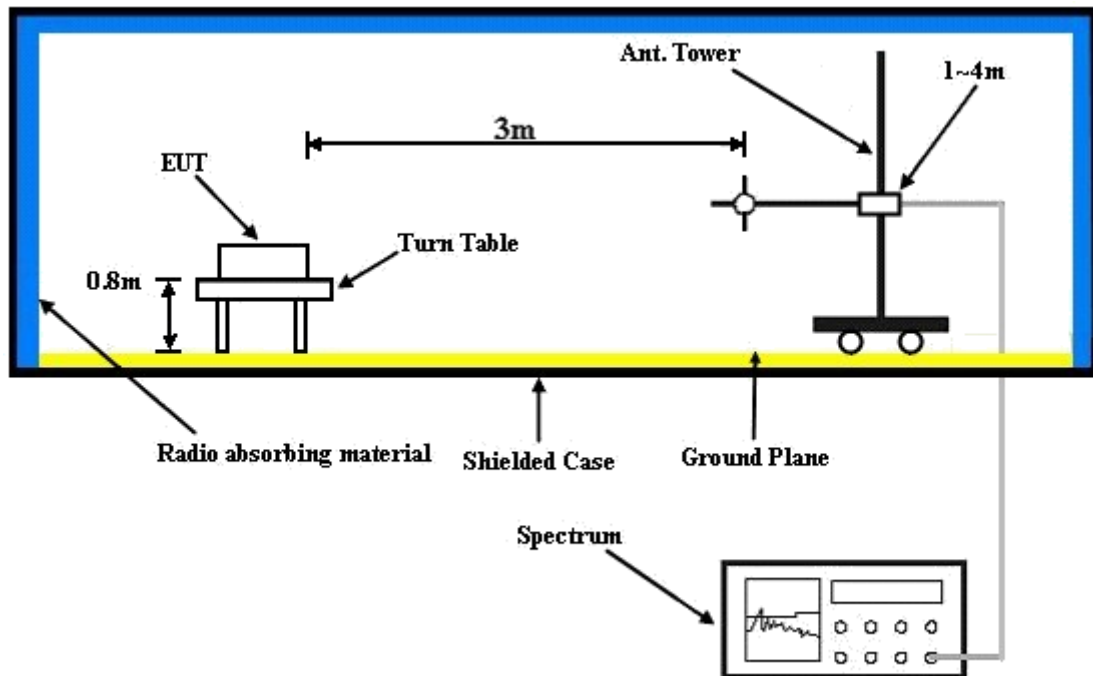

For the actual test configuration, please refer to the attached file (Test Setup Photo).



A D T

### 4.6.5 TEST RESULTS

#### TEST MODE A

GSM:



Bureau Veritas Consumer Products Services Ltd., Taoyuan Branch

A D T

Data: 15

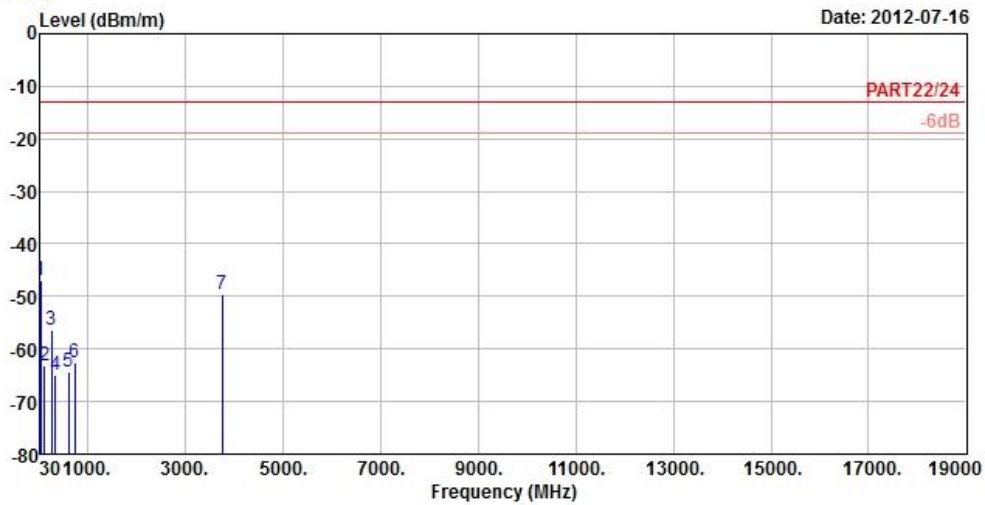

Site : 966 Chamber 5  
 Condition : PART22/24 3m EIRP\_RSE\_1G~19G\_3 HORIZONTAL  
 Brand/Model: PL83200  
 Remark : PCS1900 Link  
 Tested by : Kay Wu  
 Temperature : 25°C  
 Humidity : 65%  
 Plane : X

|   | Freq | Level   | Read   | Limit  | Over   |        |             |
|---|------|---------|--------|--------|--------|--------|-------------|
|   | MHz  | dBm/m   | Level  | Line   | Limit  | Factor | Remark      |
|   |      |         | dBm    | dBm/m  | dB     | dB/m   |             |
| 1 | pp   | 30.00   | -46.94 | -48.01 | -13.00 | -33.94 | 1.07 Peak   |
| 2 |      | 114.51  | -63.07 | -52.36 | -13.00 | -50.07 | -10.71 Peak |
| 3 |      | 253.02  | -56.50 | -50.78 | -13.00 | -43.50 | -5.72 Peak  |
| 4 |      | 335.00  | -65.09 | -58.97 | -13.00 | -52.09 | -6.12 Peak  |
| 5 |      | 608.70  | -64.23 | -64.04 | -13.00 | -51.23 | -0.19 Peak  |
| 6 |      | 733.30  | -62.71 | -64.38 | -13.00 | -49.71 | 1.67 Peak   |
| 7 |      | 3760.00 | -49.55 | -42.82 | -13.00 | -36.55 | -6.73 Peak  |



A D T



Bureau Veritas Consumer Products Services Ltd., Taoyuan Branch

A D T

Data: 16

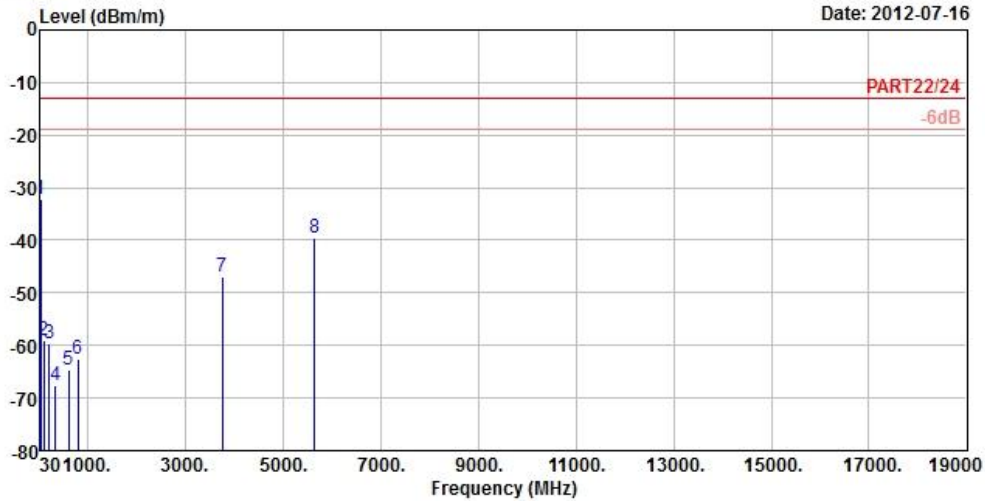

Site : 966 Chamber 5  
 Condition : PART22/24 3m EIRP\_RSE\_1G~19G\_3 VERTICAL  
 Brand/Model: PL83200  
 Remark : PCS1900 Link  
 Tested by : Kay Wu  
 Temperature : 25°C  
 Humidity : 65%  
 Plane : X

|   | Freq | Level   | Read Level | Limit Line | Over Limit | Factor | Remark      |
|---|------|---------|------------|------------|------------|--------|-------------|
|   | MHz  | dBm/m   | dBm        | dBm/m      | dB         | dB/m   |             |
| 1 | pp   | 30.00   | -32.08     | -33.15     | -13.00     | -19.08 | 1.07 Peak   |
| 2 |      | 99.93   | -58.99     | -48.59     | -13.00     | -45.99 | -10.40 Peak |
| 3 |      | 209.55  | -59.61     | -52.10     | -13.00     | -46.61 | -7.51 Peak  |
| 4 |      | 344.10  | -67.73     | -61.68     | -13.00     | -54.73 | -6.05 Peak  |
| 5 |      | 599.60  | -64.57     | -64.19     | -13.00     | -51.57 | -0.38 Peak  |
| 6 |      | 790.70  | -62.53     | -64.59     | -13.00     | -49.53 | 2.06 Peak   |
| 7 |      | 3760.00 | -46.98     | -40.25     | -13.00     | -33.98 | -6.73 Peak  |
| 8 |      | 5640.00 | -39.52     | -39.73     | -13.00     | -26.52 | 0.21 Peak   |



A D T

EDGE:



Bureau Veritas Consumer Products Services Ltd., Taoyuan Branch

A D T

Data: 15

Date: 2012-07-17

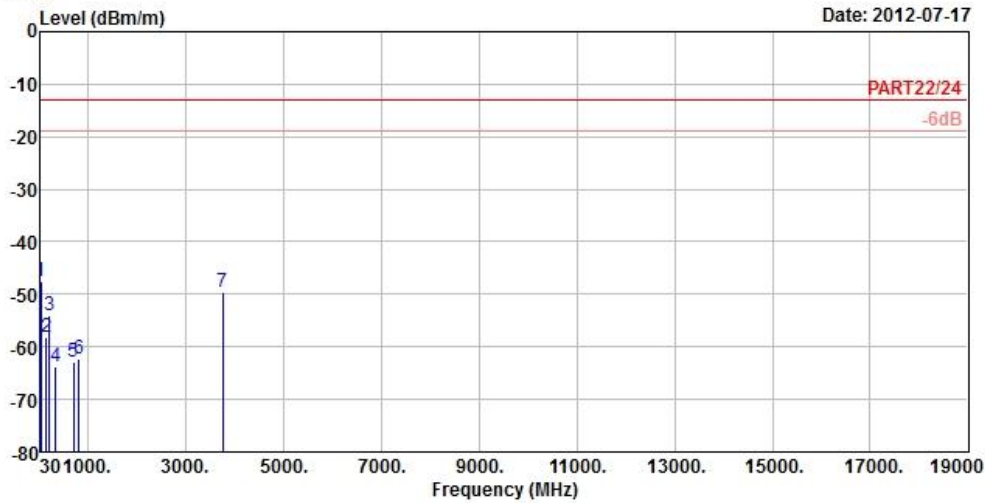

Site : 966 Chamber 5  
 Condition : PART22/24 3m EIRP\_RSE\_1G~19G\_3 HORIZONTAL  
 Brand/Model: PL83200  
 Remark : EDGE1900 Link  
 Tested by : Kay Wu  
 Temperature : 25°C  
 Humidity : 65%  
 Plane : X

|   | Freq | Level   | Read Level | Limit Line | Over Limit | Factor | Remark     |
|---|------|---------|------------|------------|------------|--------|------------|
|   | MHz  | dBm/m   | dBm        | dBm/m      | dB         | dB/m   |            |
| 1 | pp   | 30.00   | -47.65     | -48.72     | -13.00     | -34.65 | 1.07 Peak  |
| 2 |      | 146.37  | -58.15     | -52.04     | -13.00     | -45.15 | -6.11 Peak |
| 3 |      | 206.85  | -54.10     | -46.46     | -13.00     | -41.10 | -7.64 Peak |
| 4 |      | 330.10  | -63.66     | -57.50     | -13.00     | -50.66 | -6.16 Peak |
| 5 |      | 696.90  | -62.74     | -64.14     | -13.00     | -49.74 | 1.40 Peak  |
| 6 |      | 821.50  | -62.18     | -64.43     | -13.00     | -49.18 | 2.25 Peak  |
| 7 |      | 3760.00 | -49.46     | -42.73     | -13.00     | -36.46 | -6.73 Peak |



A D T



Bureau Veritas Consumer Products Services Ltd., Taoyuan Branch

A D T

Data: 16

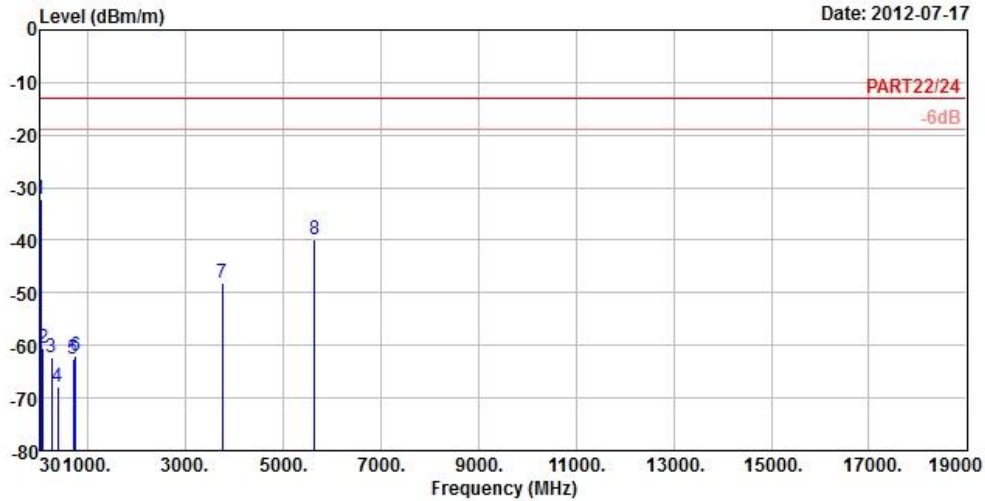

Site : 966 Chamber 5  
 Condition : PART22/24 3m EIRP\_RSE\_1G~19G\_3 VERTICAL  
 Brand/Model: PL83200  
 Remark : EDGE1900 Link  
 Tested by : Kay Wu  
 Temperature : 25°C  
 Humidity : 65%  
 Plane : X

|   | Freq | Level   | Read Level | Limit Line | Over Limit | Factor | Remark      |
|---|------|---------|------------|------------|------------|--------|-------------|
|   | MHz  | dBm/m   | dBm        | dBm/m      | dB         | dB/m   |             |
| 1 | pp   | 30.27   | -32.25     | -33.32     | -13.00     | -19.25 | 1.07 Peak   |
| 2 |      | 83.46   | -60.52     | -50.16     | -13.00     | -47.52 | -10.36 Peak |
| 3 |      | 250.59  | -62.18     | -56.50     | -13.00     | -49.18 | -5.68 Peak  |
| 4 |      | 387.50  | -68.02     | -62.29     | -13.00     | -55.02 | -5.73 Peak  |
| 5 |      | 697.60  | -62.44     | -63.84     | -13.00     | -49.44 | 1.40 Peak   |
| 6 |      | 748.00  | -62.08     | -63.85     | -13.00     | -49.08 | 1.77 Peak   |
| 7 |      | 3760.00 | -48.04     | -41.31     | -13.00     | -35.04 | -6.73 Peak  |
| 8 |      | 5640.00 | -39.76     | -39.97     | -13.00     | -26.76 | 0.21 Peak   |





A D T

WCDMA:



Bureau Veritas Consumer Products Services Ltd., Taoyuan Branch

A D T

Data: 15

Date: 2012-07-17

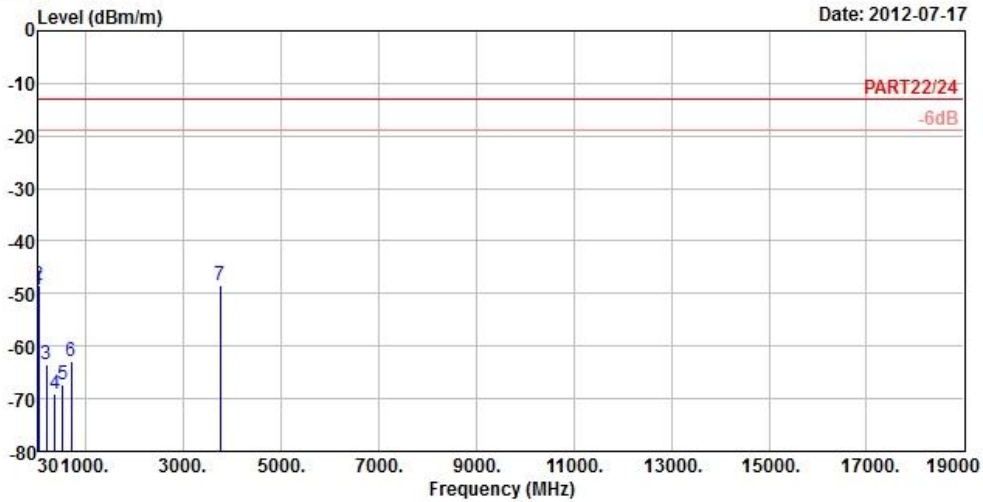

Site : 966 Chamber 5  
 Condition : PART22/24 3m EIRP\_RSE\_1G~19G\_3 HORIZONTAL  
 Brand/Model: PL83200  
 Remark : Band II Link  
 Tested by : Kay Wu  
 Temperature : 25°C  
 Humidity : 65%  
 Plane : X

|      | Read    | Limit  | Over   |        |        |            |
|------|---------|--------|--------|--------|--------|------------|
| Freq | Level   | Level  | Line   | Limit  | Factor | Remark     |
| MHz  | dBm/m   | dBm    | dBm/m  | dB     | dB/m   |            |
| 1    | 30.00   | -49.20 | -50.27 | -13.00 | -36.20 | 1.07 Peak  |
| 2    | 38.64   | -48.40 | -46.66 | -13.00 | -35.40 | -1.74 Peak |
| 3    | 192.54  | -63.50 | -56.35 | -13.00 | -50.50 | -7.15 Peak |
| 4    | 362.30  | -69.13 | -63.22 | -13.00 | -56.13 | -5.91 Peak |
| 5    | 521.20  | -67.23 | -64.70 | -13.00 | -54.23 | -2.53 Peak |
| 6    | 706.00  | -62.81 | -64.30 | -13.00 | -49.81 | 1.49 Peak  |
| 7 pp | 3760.00 | -48.32 | -41.59 | -13.00 | -35.32 | -6.73 Peak |



A D T



Bureau Veritas Consumer Products Services Ltd., Taoyuan Branch

A D T

Data: 16

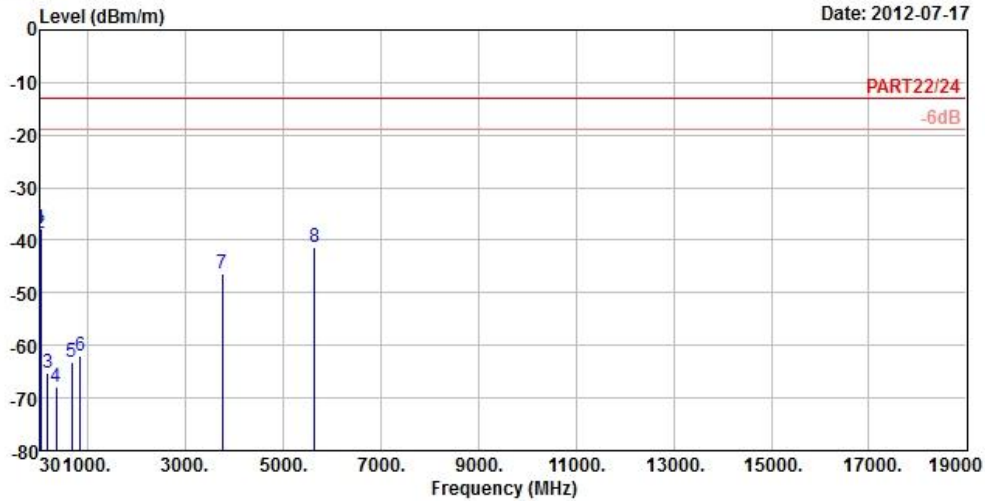

Site : 966 Chamber 5  
 Condition : PART22/24 3m EIRP\_RSE\_1G~19G\_3 VERTICAL  
 Brand/Model: PL83200  
 Remark : Band II Link  
 Tested by : Kay Wu  
 Temperature : 25°C  
 Humidity : 65%  
 Plane : X

|      | Freq    | Level  | Read   | Limit  | Over   |        |        |
|------|---------|--------|--------|--------|--------|--------|--------|
|      | MHz     | dBm/m  | Level  | Line   | Limit  | Factor | Remark |
|      |         |        | dBm    | dBm/m  | dB     |        |        |
| 1 pp | 30.54   | -37.79 | -38.13 | -13.00 | -24.79 | 0.34   | Peak   |
| 2    | 39.72   | -38.53 | -37.00 | -13.00 | -25.53 | -1.53  | Peak   |
| 3    | 170.94  | -65.37 | -58.65 | -13.00 | -52.37 | -6.72  | Peak   |
| 4    | 346.20  | -67.87 | -61.83 | -13.00 | -54.87 | -6.04  | Peak   |
| 5    | 663.30  | -63.31 | -64.10 | -13.00 | -50.31 | 0.79   | Peak   |
| 6    | 846.00  | -62.02 | -64.41 | -13.00 | -49.02 | 2.39   | Peak   |
| 7    | 3760.00 | -46.27 | -39.54 | -13.00 | -33.27 | -6.73  | Peak   |
| 8    | 5640.00 | -41.35 | -41.56 | -13.00 | -28.35 | 0.21   | Peak   |



A D T

CDMA:



Bureau Veritas Consumer Products Services Ltd., Taoyuan Branch

A D T

Data: 15

Date: 2012-07-17

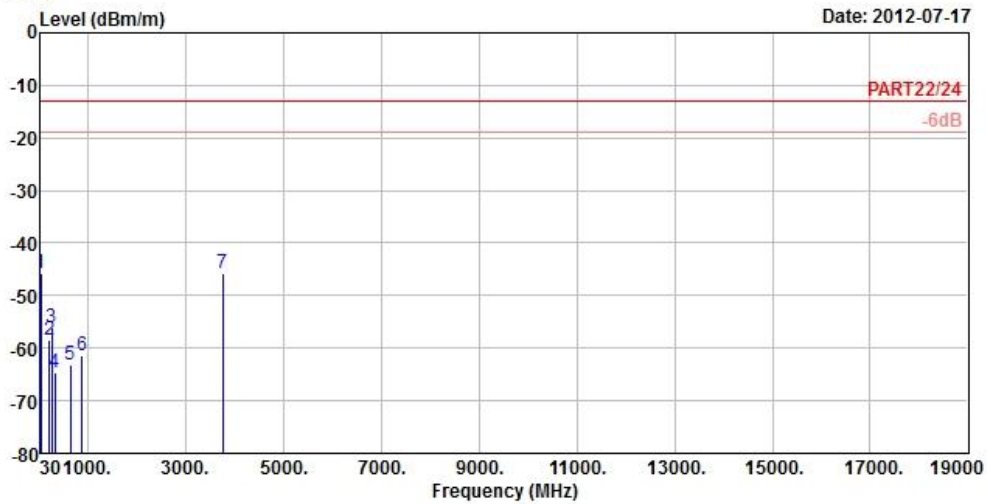

Site : 966 Chamber 5  
 Condition : PART22/24 3m EIRP\_RSE\_1G~19G\_3 HORIZONTAL  
 Brand/Model: PL83200  
 Remark : 1XRTT1900 Link  
 Tested by : Kay Wu  
 Temperature : 25°C  
 Humidity : 65%  
 Plane : Y

|   | Freq | Level   | Read Level | Limit Line | Over Limit | Factor | Remark     |
|---|------|---------|------------|------------|------------|--------|------------|
|   | MHz  | dBm/m   | dBm        | dBm/m      | dB         | dB/m   |            |
| 1 | pp   | 30.00   | -45.82     | -46.89     | -13.00     | -32.82 | 1.07 Peak  |
| 2 |      | 205.23  | -58.37     | -50.68     | -13.00     | -45.37 | -7.69 Peak |
| 3 |      | 254.91  | -56.06     | -50.31     | -13.00     | -43.06 | -5.75 Peak |
| 4 |      | 328.00  | -64.59     | -58.42     | -13.00     | -51.59 | -6.17 Peak |
| 5 |      | 644.40  | -63.23     | -63.67     | -13.00     | -50.23 | 0.44 Peak  |
| 6 |      | 881.00  | -61.40     | -63.99     | -13.00     | -48.40 | 2.59 Peak  |
| 7 |      | 3760.00 | -45.85     | -39.12     | -13.00     | -32.85 | -6.73 Peak |



A D T



Bureau Veritas Consumer Products Services Ltd., Taoyuan Branch

A D T

Data: 16

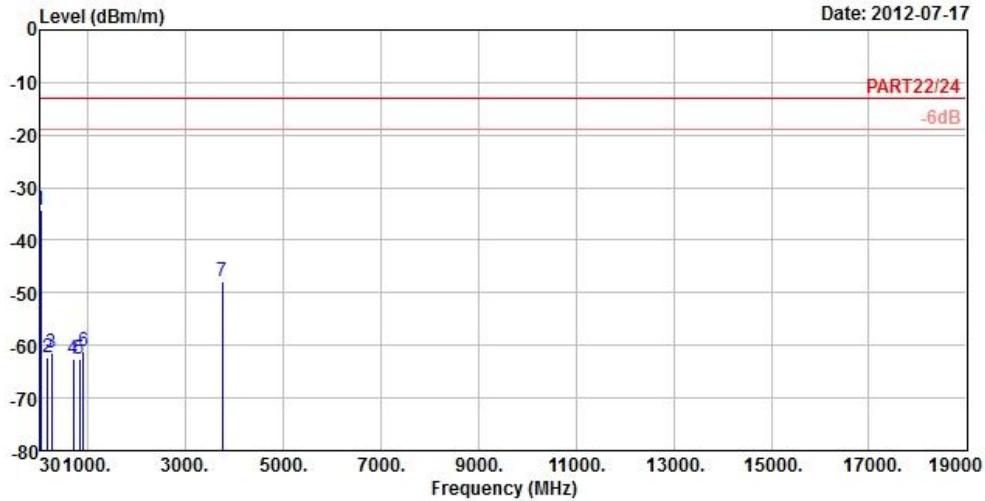

Site : 966 Chamber 5  
 Condition : PART22/24 3m EIRP\_RSE\_1G~19G\_3 VERTICAL  
 Brand/Model: PL83200  
 Remark : 1XRTT1900 Link  
 Tested by : Kay Wu  
 Temperature : 25°C  
 Humidity : 65%  
 Plane : Y

|   | Freq | Level   | Read Level | Limit Line | Over Limit | Factor | Remark     |
|---|------|---------|------------|------------|------------|--------|------------|
|   | MHz  | dBm/m   | dBm        | dBm/m      | dB         | dB/m   |            |
| 1 | pp   | 30.27   | -34.11     | -35.18     | -13.00     | -21.11 | 1.07 Peak  |
| 2 |      | 171.75  | -62.19     | -55.46     | -13.00     | -49.19 | -6.73 Peak |
| 3 |      | 251.94  | -61.54     | -55.83     | -13.00     | -48.54 | -5.71 Peak |
| 4 |      | 696.20  | -62.45     | -63.83     | -13.00     | -49.45 | 1.38 Peak  |
| 5 |      | 825.00  | -62.56     | -64.83     | -13.00     | -49.56 | 2.27 Peak  |
| 6 |      | 912.50  | -61.17     | -64.12     | -13.00     | -48.17 | 2.95 Peak  |
| 7 |      | 3760.00 | -47.93     | -41.20     | -13.00     | -34.93 | -6.73 Peak |



A D T

TEST MODE B

GSM:



Bureau Veritas Consumer Products Services Ltd., Taoyuan Branch

A D T

Data: 15

Date: 2012-09-18

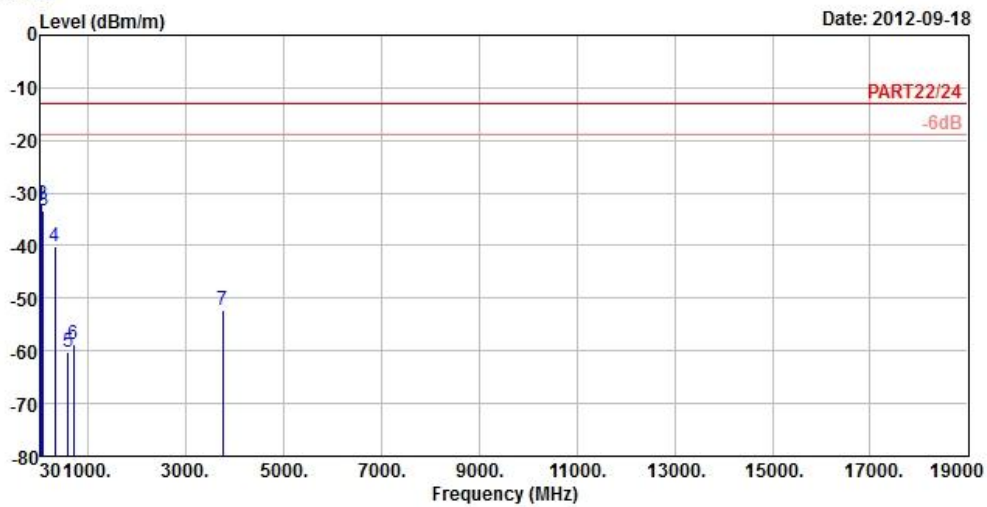

Site : 966 Chamber 5  
 Condition : PART22/24 3m EIRP\_RSE\_1G~19G\_3 HORIZONTAL  
 Brand/Model: PL83200  
 Remark : PCS1900 Link  
 Tested by : Kay Wu  
 Temperature : 25°C  
 Humidity : 65%  
 Plane : (無線充電

|      | Read    | Limit  | Over   |        |        |             |
|------|---------|--------|--------|--------|--------|-------------|
| Freq | Level   | Level  | Line   | Limit  | Factor | Remark      |
| MHz  | dBm/m   | dBm    | dBm/m  | dB     | dB/m   |             |
| 1    | 39.45   | -32.36 | -30.83 | -13.00 | -19.36 | -1.53 Peak  |
| 2 pp | 57.54   | -32.05 | -26.40 | -13.00 | -19.05 | -5.65 Peak  |
| 3    | 83.46   | -33.23 | -22.87 | -13.00 | -20.23 | -10.36 Peak |
| 4    | 314.70  | -40.14 | -33.87 | -13.00 | -27.14 | -6.27 Peak  |
| 5    | 584.20  | -60.31 | -59.51 | -13.00 | -47.31 | -0.80 Peak  |
| 6    | 708.80  | -58.75 | -60.26 | -13.00 | -45.75 | 1.51 Peak   |
| 7    | 3760.00 | -52.38 | -45.65 | -13.00 | -39.38 | -6.73 Peak  |



A D T



Bureau Veritas Consumer Products Services Ltd., Taoyuan Branch

A D T

Data: 16

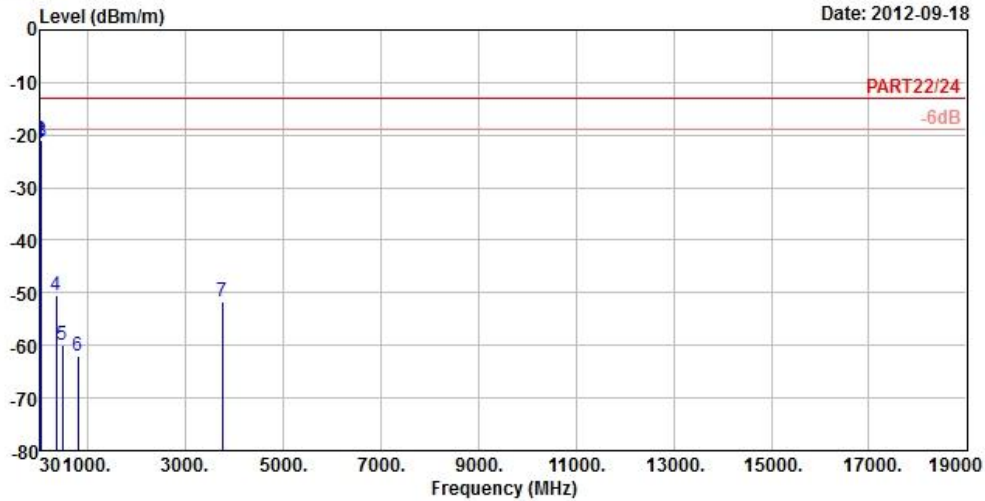

Site : 966 Chamber 5  
 Condition : PART22/24 3m EIRP\_RSE\_1G~19G\_3 VERTICAL  
 Brand/Model: PL83200  
 Remark : PCS1900 Link  
 Tested by : Kay Wu  
 Temperature : 25°C  
 Humidity : 65%  
 Plane : (無線充電)

|      | Freq    | Level  | Read Level | Limit Line | Over Limit | Factor | Remark |
|------|---------|--------|------------|------------|------------|--------|--------|
|      | MHz     | dBm/m  | dBm        | dBm/m      | dB         | dB/m   |        |
| 1    | 33.24   | -21.43 | -20.32     | -13.00     | -8.43      | -1.11  | Peak   |
| 2 pp | 39.18   | -21.01 | -19.27     | -13.00     | -8.01      | -1.74  | Peak   |
| 3    | 58.08   | -21.24 | -15.44     | -13.00     | -8.24      | -5.80  | Peak   |
| 4    | 353.20  | -50.49 | -44.51     | -13.00     | -37.49     | -5.98  | Peak   |
| 5    | 474.30  | -59.93 | -56.18     | -13.00     | -46.93     | -3.75  | Peak   |
| 6    | 801.90  | -61.96 | -64.10     | -13.00     | -48.96     | 2.14   | Peak   |
| 7    | 3760.00 | -51.72 | -44.99     | -13.00     | -38.72     | -6.73  | Peak   |





## 5 PHOTOGRAPHS OF THE TEST CONFIGURATION

Please refer to the attached file (Test Setup Photo).



## 6 INFORMATION ON THE TESTING LABORATORIES

We, Bureau Veritas Consumer Products Services (H.K.) Ltd., Taoyuan Branch, were founded in 1988 to provide our best service in EMC, Radio, Telecom and Safety consultation. Our laboratories are accredited and approved according to ISO/IEC 17025.

If you have any comments, please feel free to contact us at the following:

**Linko EMC/RF Lab:**

Tel: 886-2-26052180

Fax: 886-2-26051924

**Hsin Chu EMC/RF Lab:**

Tel: 886-3-5935343

Fax: 886-3-5935342

**Hwa Ya EMC/RF/Safety/Telecom Lab:**

Tel: 886-3-3183232

Fax: 886-3-3270892

**Email:** [service.adt@tw.bureauveritas.com](mailto:service.adt@tw.bureauveritas.com)

**Web Site:** [www.adt.com.tw](http://www.adt.com.tw)

The address and road map of all our labs can be found in our web site also.





A D T

## 7 APPENDIX A – MODIFICATIONS RECORDERS FOR ENGINEERING CHANGES TO THE EUT BY THE LAB

No any modifications were made to the EUT by the lab during the test.

---END---