



FCC RF Test Report

APPLICANT : HTC Corporation
EQUIPMENT : Smartphone
MODEL NAME : PL80120
FCC ID : NM8PL80120
STANDARD : FCC Part 15 Subpart C §15.247
CLASSIFICATION : (DSS) Spread Spectrum Transmitter

The product was received on Aug. 16, 2012 and completely tested on Sep. 27, 2012. We, SPORTON INTERNATIONAL INC., would like to declare that the tested sample has been evaluated in accordance with the procedures and shown the compliance with the applicable technical standards.

The test results in this report apply exclusively to the tested model / sample. Without written approval of SPORTON INTERNATIONAL INC., the test report shall not be reproduced except in full.

Reviewed by:

Jones Tsai / Manager



SPORTON INTERNATIONAL INC.

No. 52, Hwa Ya 1st Rd., Hwa Ya Technology Park, Kwei-Shan Hsiang, Tao Yuan Hsien, Taiwan, R.O.C.



TABLE OF CONTENTS

REVISION HISTORY..... 3

SUMMARY OF TEST RESULT 4

1 GENERAL DESCRIPTION..... 5

 1.1 Applicant 5

 1.2 Manufacturer..... 5

 1.3 Feature of Equipment Under Test 5

 1.4 Testing Site 6

 1.5 Applied Standards 6

 1.6 Ancillary Equipment List 6

2 TEST CONFIGURATION OF EQUIPMENT UNDER TEST..... 7

 2.1 RF Output Power 7

 2.2 Test Mode..... 8

 2.3 Connection Diagram of Test System..... 9

 2.4 RF Utility 9

3 TEST RESULT 10

 3.1 Number of Channel Measurement 10

 3.2 Hopping Channel Separation Measurement 12

 3.3 Dwell Time Measurement..... 19

 3.4 20dB Bandwidth Measurement 21

 3.5 Peak Output Power Measurement 28

 3.6 Conducted Band Edges Measurement..... 35

 3.7 Conducted Spurious Emission Measurement 38

 3.8 Radiated Band Edges and Spurious Emission Measurement 42

 3.9 AC Conducted Emission Measurement..... 52

 3.10 Antenna Requirements 56

4 LIST OF MEASURING EQUIPMENT..... 57

5 UNCERTAINTY OF EVALUATION..... 58

APPENDIX A. SETUP PHOTOGRAPHS



REVISION HISTORY

REPORT NO.	VERSION	DESCRIPTION	ISSUED DATE
FR281609A	Rev. 01	Initial issue of report	Oct. 31, 2012

SUMMARY OF TEST RESULT

Report Section	FCC Rule	IC Rule	Description	Limit	Result	Remark
3.1	15.247(a)(1)	A8.4(2)	Number of Channels	≥ 15Chs	Pass	-
3.2	15.247(a)(1)	A8.1(b)	Hopping Channel Separation	≥ 2/3 of 20dB BW	Pass	-
3.3	15.247(a)(1)	A8.1(d)	Dwell Time of Each Channel	≤ 0.4sec in 31.6sec period	Pass	-
3.4	15.247(a)(1)	A8.1(a)	20dB Bandwidth	NA	Pass	-
3.5	15.247(b)(1)	A8.1(b)	Peak Output Power	≤ 1 w for 1Mbps ≤ 125 Mw for 2, 3Mbps	Pass	-
3.6	15.247(d)	A8.5	Conducted Band Edges	≤ 20dBc	Pass	-
3.7	15.247(d)	A8.5	Conducted Spurious Emission	≤ 20dBc	Pass	-
0	15.247(d)	A8.5	Radiated Band Edges and Radiated Spurious Emission	15.209(a) & 15.247(d)	Pass	Under limit 6.26 dB at 48.360 MHz
3.9	15.207	Gen 7.2.4	AC Conducted Emission	15.207(a)	Pass	Under limit 12.50 dB at 0.566 MHz
3.10	15.203 & 15.247(b)	A8.4	Antenna Requirement	N/A	Pass	-

1 General Description

1.1 Applicant

HTC Corporation

No. 23, Xinghua Rd., Taoyuan City, Taoyuan County 330, Taiwan.

1.2 Manufacturer

HTC Corporation

No. 23, Xinghua Rd., Taoyuan City, Taoyuan County 330, Taiwan.

1.3 Feature of Equipment Under Test

Product Feature	
Equipment	Smartphone
Model Name	PL80120
FCC ID	NM8PL80120
Sample 1	EUT with LCM 1 and Main Camera 1
Sample 2	EUT with LCM 2 and Main Camera 2
EUT supports Radios application	CDMA/EV-DO /LTE/ WLAN 11abgn / Bluetooth / NFC
EUT Stage	Production Unit

Remark: The above EUT's information was declared by manufacturer. Please refer to the specifications or user's manual for more detailed description.

Product Specification subjective to this standard	
Tx/Rx Frequency Range	2402 MHz ~ 2480 MHz
Number of Channels	79
Carrier Frequency of Each Channel	2402+n*1 MHz; n=0~78
Maximum Output Power to Antenna	Bluetooth (1Mbps) : 6.50 dBm (0.0045 W) Bluetooth EDR (2Mbps) : 5.01 dBm (0.0032 W) Bluetooth EDR (3Mbps) : 5.49 dBm (0.0035 W)
Antenna Type	PIFA Antenna type with gain -0.20 dBi
Type of Modulation	Bluetooth (1Mbps) : GFSK Bluetooth 2.1 EDR (2Mbps) : $\pi/4$ -DQPSK Bluetooth 2.1 EDR (3Mbps) : 8-DPSK Bluetooth 3.0 EDR : GFSK, $\pi/4$ -DQPSK, 8-DPSK

1.4 Testing Site

Test Site	SPORTON INTERNATIONAL INC.			
Test Site Location	No. 52, Hwa Ya 1 st Rd., Hwa Ya Technology Park, Kwei-Shan Hsiang, Tao Yuan Hsien, Taiwan, R.O.C. TEL: +886-3-3273456 / FAX: +886-3-3284978			
Test Site No.	Sporton Site No.			FCC/IC Registration No.
	TH02-HY	CO05-HY	03CH06-HY	722060/4086B-1

1.5 Applied Standards

According to the specifications of the manufacturer, the EUT must comply with the requirements of the following standards:

- ♦ FCC Part 15 Subpart C §15.247
- ♦ FCC Public Notice DA 00-705
- ♦ ANSI C63.4-2003 and ANSI C63.10-2009
- ♦ IC RSS-210 Issue 8
- ♦ IC RSS-Gen Issue 3

Remark:

1. All test items were verified and recorded according to the standards and without any deviation during the test.
2. This EUT has also been tested and complied with the requirements of FCC Part 15, Subpart B, recorded in a separate test report.

1.6 Ancillary Equipment List

Item	Equipment	Trade Name	Model Name	FCC ID	Data Cable	Power Cord
1.	System Simulator	R&S	CMU 200	N/A	N/A	Unshielded, 1.8 m
2.	Bluetooth Base Station	R&S	CBT32	N/A	N/A	Unshielded, 1.8 m
3.	WLAN AP	D-Link	DIR-628	KA2DIR628A2	N/A	Unshielded, 1.8 m
4.	Notebook	DELL	Latitude E6320	FCC DoC	N/A	AC I/P: Unshielded, 1.2 m DC O/P: Shielded, 1.8 m
5.	Bluetooth Earphone	Sony Ericsson	MW600	PY7DDA-2029	N/A	N/A

2 Test Configuration of Equipment Under Test

2.1 RF Output Power

Preliminary tests were performed in different data rate and recorded the RF output power in the following table:

Channel	Frequency	Bluetooth RF Output Power		
		Data Rate / Modulation		
		GFSK	$\pi/4$ -DQPSK	8-DPSK
		1Mbps	2Mbps	3Mbps
Ch00	2402MHz	6.50 dBm	5.01 dBm	5.49 dBm
Ch39	2441MHz	6.32 dBm	4.88 dBm	5.37 dBm
Ch78	2480MHz	6.26 dBm	4.77 dBm	5.34 dBm

Remark:

1. All the test data for each data rate were verified, but only the worst case was reported.
2. The data rate was set in 1Mbps for all the test items due to the highest RF output power.
3. The EUT is programmed to transmit signals continuously for all testing.

2.2 Test Mode

The EUT has been associated with peripherals pursuant to ANSI C63.4-2003 and ANSI C63.10-2009 and configuration operated in a manner tended to maximize its emission characteristics in a typical application. Frequency range investigated: conduction (150 KHz to 30 MHz), radiation (9 KHz to the 10th harmonic of the highest fundamental frequency or to 40 GHz, whichever is lower).

Pre-scanned tests, X, Y, Z in three orthogonal panels, were conducted to determine the final configuration from all possible combinations.

The following tables are showing the test modes as the worst cases (Y plane) and recorded in this report.

Test Cases			
Test Item	Data Rate / Modulation		
	Bluetooth 1Mbps GFSK	Bluetooth EDR 2Mbps $\pi/4$ -DQPSK	Bluetooth EDR 3Mbps 8-DPSK
Conducted TCs	Mode 1: CH00_2402 MHz Mode 2: CH39_2441 MHz Mode 3: CH78_2480 MHz	Mode 4: CH00_2402 MHz Mode 5: CH39_2441 MHz Mode 6: CH78_2480 MHz	Mode 7: CH00_2402 MHz Mode 8: CH39_2441 MHz Mode 9: CH78_2480 MHz
Radiated TCs	Mode 1: CH00_2402 MHz Mode 2: CH39_2441 MHz Mode 3: CH78_2480 MHz	Pretest	Pretest
AC Conducted Emission	Mode 1 :CDMA2000 BC15 Idle + Bluetooth Link + WLAN (2.4G) Link + MPEG4 + Earphone 1 + Battery 1 + USB Cable 1 (Charging from Adapter 1) for Sample 1 Mode 2 :CDMA2000 BC15 Idle + Bluetooth Link + WLAN (2.4G) Link + MPEG4 + Earphone 1 + Battery 1 + USB Cable 1 (Charging from Adapter 1) for Sample 2		
Remark: <ol style="list-style-type: none"> For radiated TCs, the data rate was set in 1Mbps due to the highest RF output power; only the data of these modes was reported. For conducted emission, the worst case is mode 2; only the test data of this mode was reported. For radiated TCs were performance with Sample 1. 			

2.3 Connection Diagram of Test System

<Bluetooth Tx Mode>

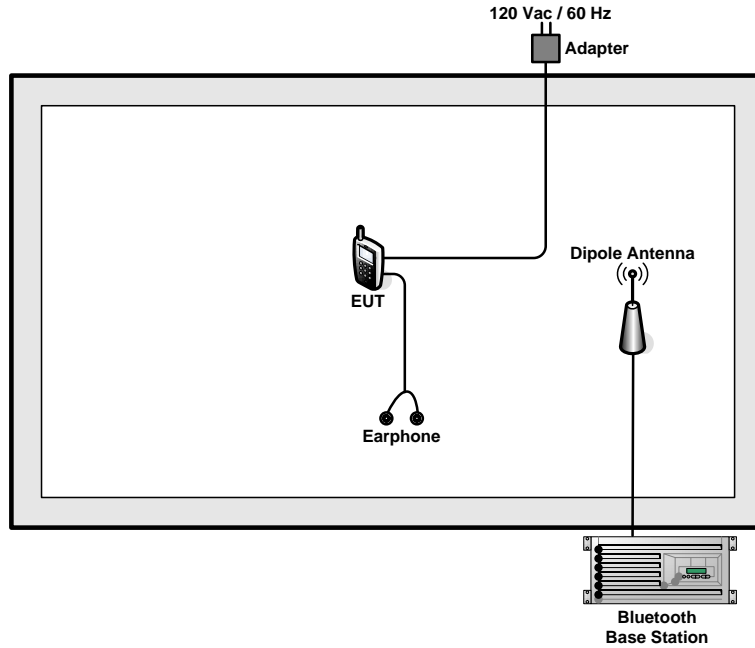

<AC Conducted Emission Mode>

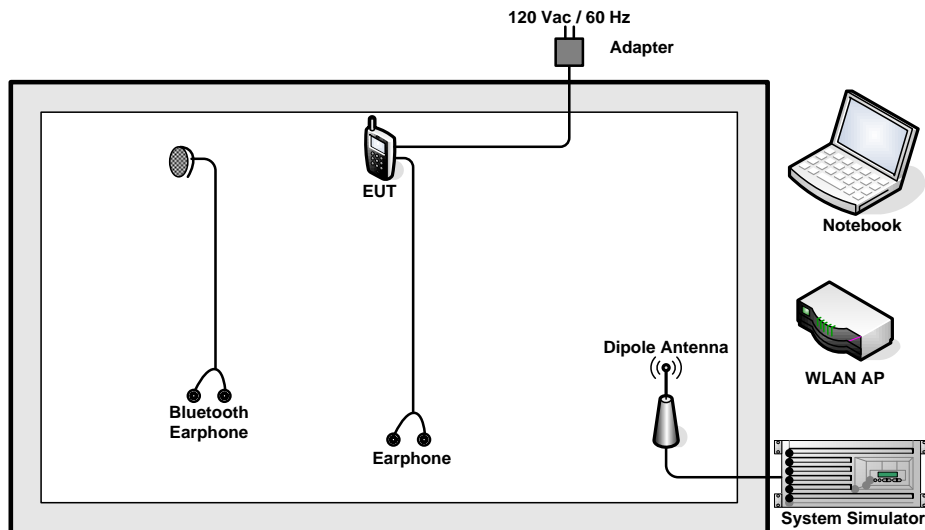

2.4 RF Utility

For Bluetooth function, programmed RF utility, "Bluetooth Test Mode" installed in the EUT make the EUT provides functions like channel selection and power level for continuous transmitting and receiving signals.

3 Test Result

3.1 Number of Channel Measurement

3.1.1 Limits of Number of Hopping Frequency

Frequency hopping systems in the 2400-2483.5 MHz band shall use at least 15 channels.

3.1.2 Measuring Instruments

See list of measuring instruments of this test report.

3.1.3 Test Procedure

1. The testing follows FCC Public Notice DA 00-705 Measurement Guidelines.
2. The RF output of EUT was connected to the spectrum analyzer by a low loss cable.
3. Set to the maximum power setting and enable the EUT transmit continuously.
4. Enable the EUT hopping function.
5. Use the following spectrum analyzer settings: Span = the frequency band of operation; RBW \geq 1% of the span; VBW \geq RBW; Sweep = auto; Detector function = peak; Trace = max hold.
6. The number of hopping frequency used is defined as the number of total channel.

3.1.4 Test Setup

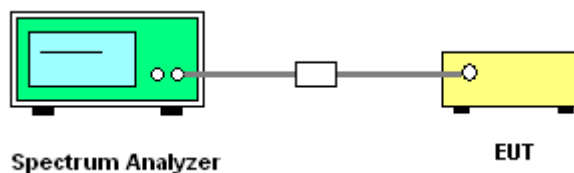

3.1.5 Test Result of Number of Hopping Frequency

Test Mode :	1Mbps	Temperature :	24~26°C
Test Engineer :	Book Lin	Relative Humidity :	50~53%
Number of Hopping Channels (Channel)		Limits (Channel)	
79		> 15	
		Pass/Fail	
		Pass	



Number of Hopping Channel Plot on Channel 00 - 78

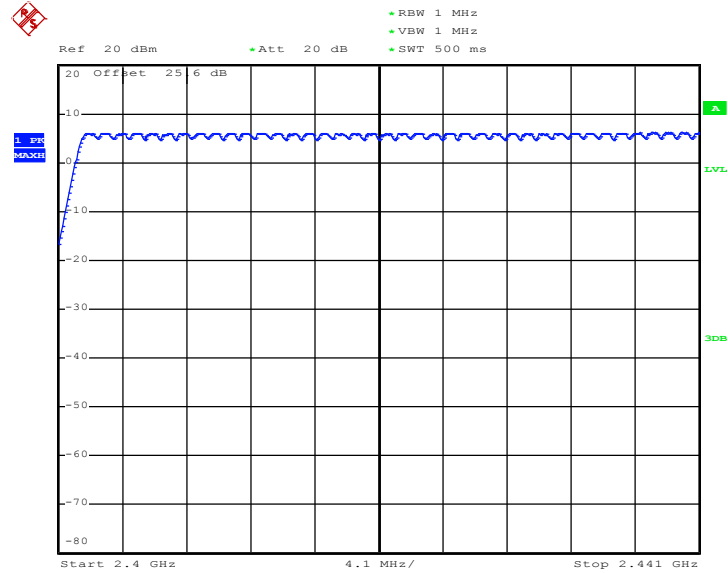

Date: 21.SEP.2012 17:23:58

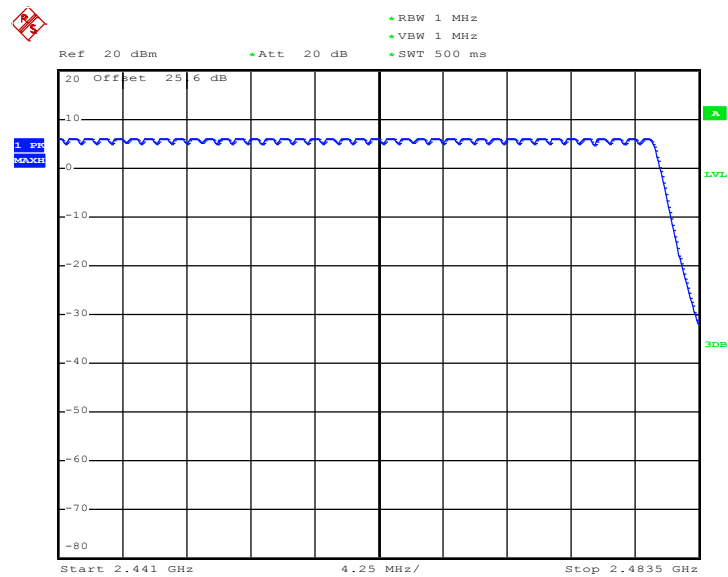

Date: 21.SEP.2012 17:28:26

3.2 Hopping Channel Separation Measurement

3.2.1 Limit of Hopping Channel Separation

Frequency hopping systems operating in the 2400-2483.5 MHz band may have hopping channel carrier frequencies that are separated by 25 KHz or two-thirds of the 20 dB bandwidth of the hopping channel, whichever is greater.

3.2.2 Measuring Instruments

See list of measuring instruments of this test report.

3.2.3 Test Procedures

1. The testing follows FCC Public Notice DA 00-705 Measurement Guidelines.
2. The RF output of EUT was connected to the spectrum analyzer by a low loss cable.
3. Set to the maximum power setting and enable the EUT transmit continuously.
4. Enable the EUT hopping function.
5. Use the following spectrum analyzer settings:
Span = wide enough to capture the peaks of two adjacent channels; RBW \geq 1% of the span;
VBW \geq RBW; Sweep = auto; Detector function = peak; Trace = max hold.

3.2.4 Test Setup

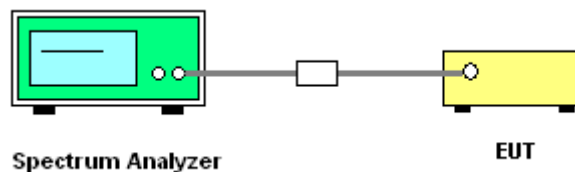



3.2.5 Test Result of Hopping Channel Separation

Test Mode :	1Mbps	Temperature :	24~26°C
Test Engineer :	Book Lin	Relative Humidity :	50~53%

Channel	Frequency (MHz)	Frequency Separation (MHz)	(2/3 of 20dB BW) Limits (MHz)	Pass/Fail
00	2402	1.002	0.6027	Pass
39	2441	1.002	0.6027	Pass
78	2480	1.002	0.6027	Pass

Channel Separation Plot on Channel 00 - 01

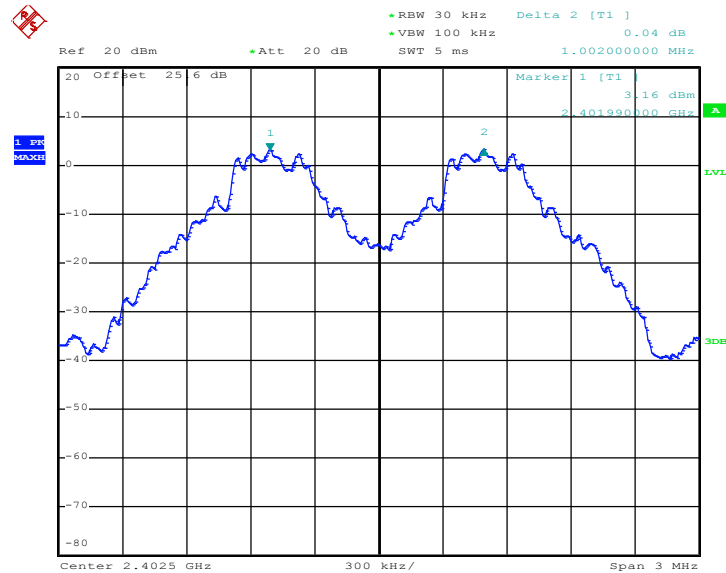

Date: 21.SEP.2012 16:47:54



Channel Separation Plot on Channel 39 - 40

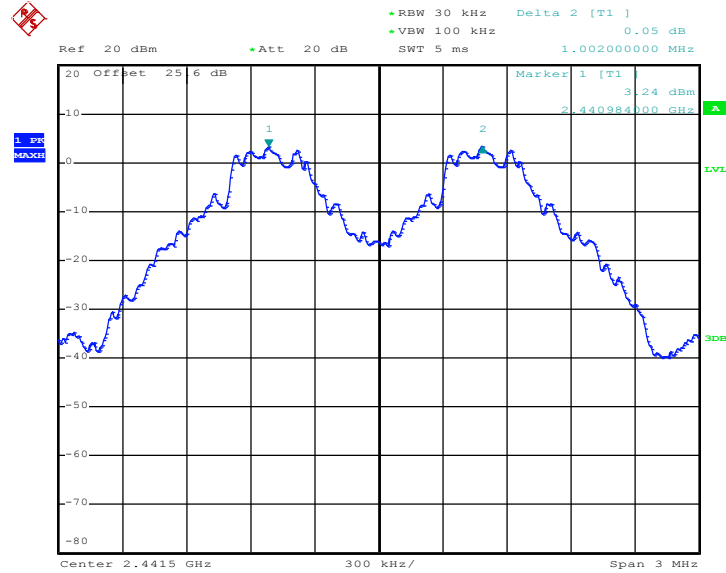

Date: 21.SEP.2012 16:48:35

Channel Separation Plot on Channel 77 - 78

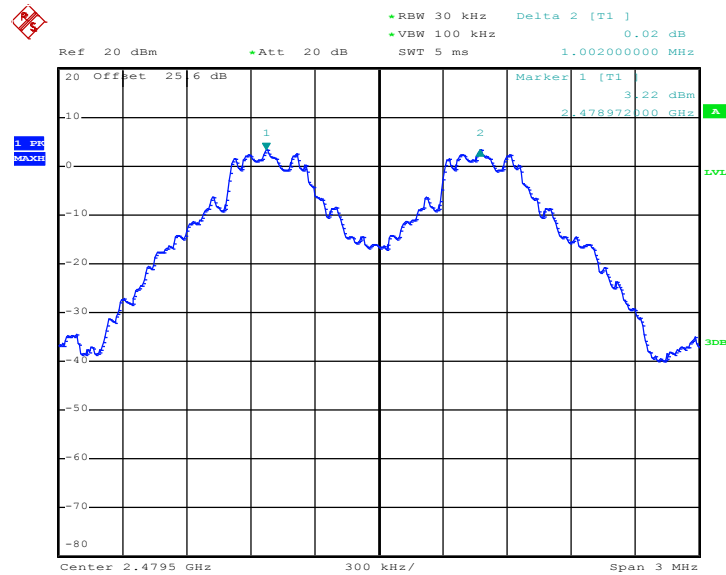

Date: 21.SEP.2012 16:49:14



Test Mode :	2Mbps	Temperature :	24~26°C
Test Engineer :	Book Lin	Relative Humidity :	50~53%

Channel	Frequency (MHz)	Frequency Separation (MHz)	(2/3 of 20dB BW) Limits (MHz)	Pass/Fail
00	2402	1.002	0.8960	Pass
39	2441	1.002	0.9000	Pass
78	2480	1.002	0.8960	Pass

Channel Separation Plot on Channel 00 - 01

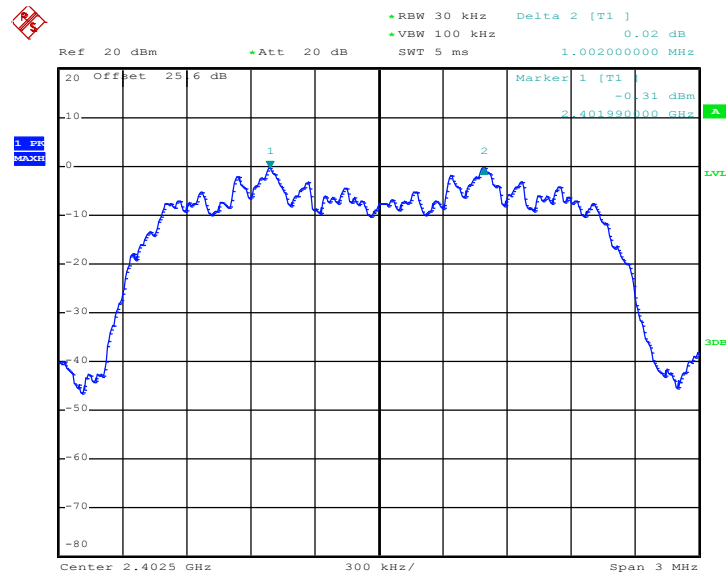

Date: 21.SEP.2012 16:51:04



Channel Separation Plot on Channel 39 - 40

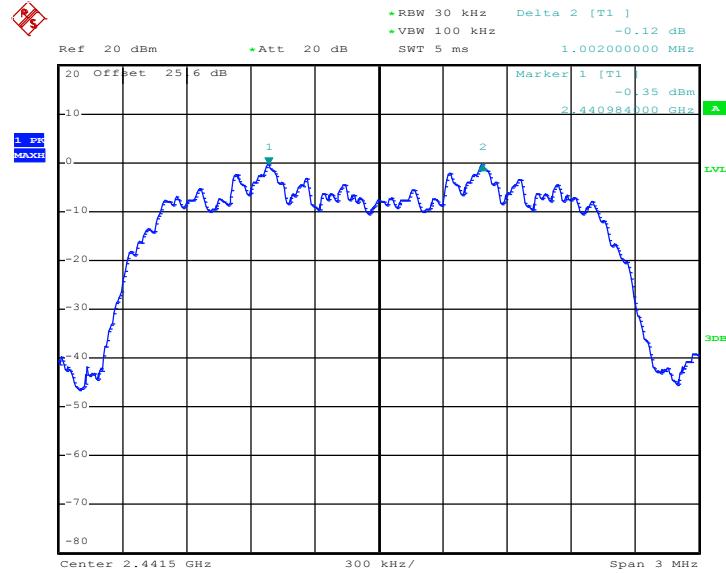

Date: 21.SEP.2012 16:51:45

Channel Separation Plot on Channel 77 - 78

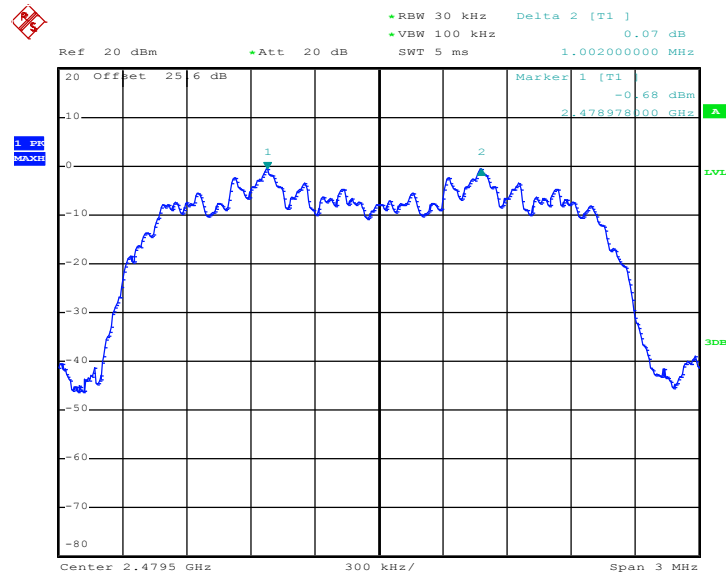

Date: 21.SEP.2012 16:52:24



Test Mode :	3Mbps	Temperature :	24~26°C
Test Engineer :	Book Lin	Relative Humidity :	50~53%

Channel	Frequency (MHz)	Frequency Separation (MHz)	(2/3 of 20dB BW) Limits (MHz)	Pass/Fail
00	2402	1.002	0.8640	Pass
39	2441	1.002	0.8600	Pass
78	2480	1.002	0.8600	Pass

Channel Separation Plot on Channel 00 - 01

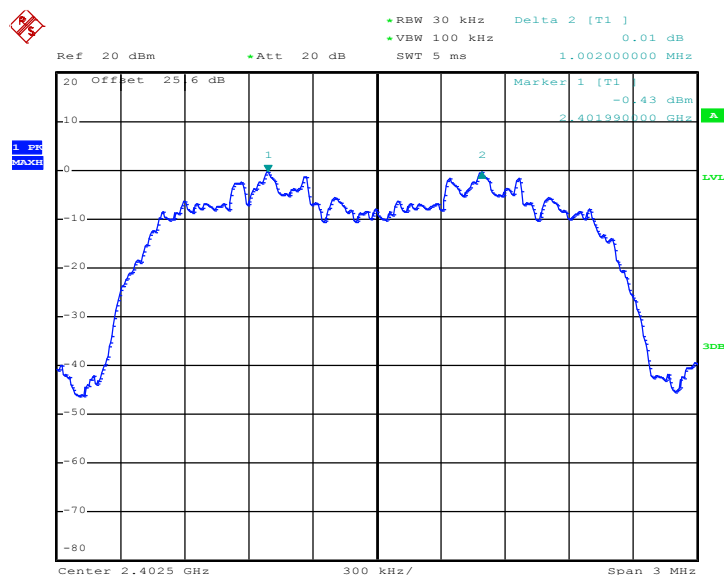

Date: 21.SEP.2012 16:53:04



Channel Separation Plot on Channel 39 - 40

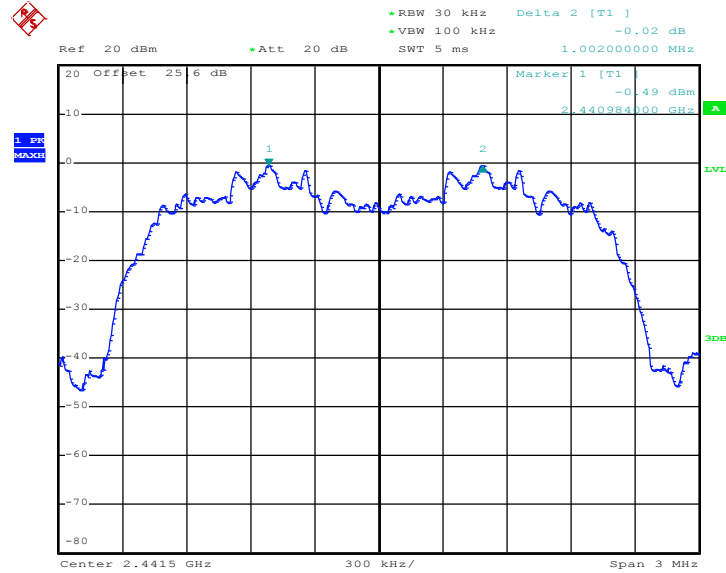

Date: 21.SEP.2012 16:53:49

Channel Separation Plot on Channel 77 - 78

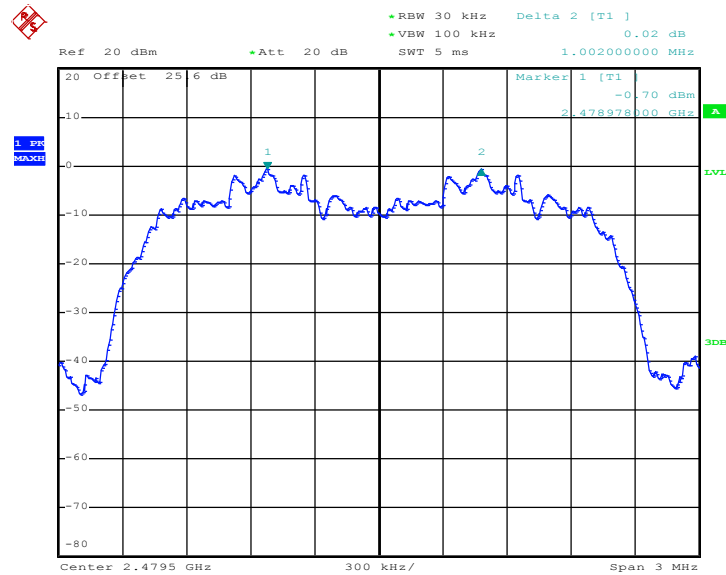

Date: 21.SEP.2012 16:54:29

3.3 Dwell Time Measurement

3.3.1 Limit of Dwell Time

The average time of occupancy on any channel shall not be greater than 0.4 seconds within a period of 0.4 seconds multiplied by the number of hopping channels employed.

3.3.2 Measuring Instruments

See list of measuring instruments of this test report.

3.3.3 Test Procedures

1. The testing follows FCC Public Notice DA 00-705 Measurement Guidelines.
2. The RF output connector was connected to the spectrum analyzer through a low loss cable.
3. Set to the maximum power setting and enable the EUT transmit continuously.
4. Enable the EUT hopping function.
5. Use the following spectrum analyzer settings: Span = zero span, centered on a hopping channel; RBW = 1 MHz; VBW ≥ RBW; Sweep = as necessary to capture the entire dwell time per hopping channel; Detector function = peak; Trace = max hold.

3.3.4 Test Setup

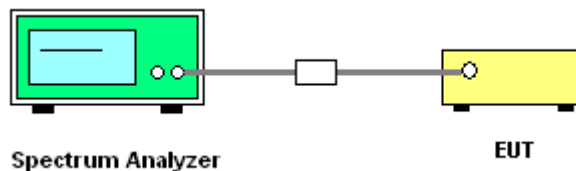

3.3.5 Test Result of Dwell Time

Test Mode :	DH5	Temperature :	24~26°C
Test Engineer :	Book Lin	Relative Humidity :	50~53%

Package Mode	Average Hopping Channel	Package Transfer Time (usec)	Dwell Time (sec)	Limits (sec)	Pass/Fail
DH5	3.20	3000.00	0.30	0.4	Pass

Remark:

1. Dwell Time=79(channels) x 0.4(s) x average hopping channel x package transfer time
2. 79 channels come from the Hopping Channel number.
3. Average Hopping Channel = hops/sweep time
4. T: Package Transfer Time(us)



DH5 Dwell Time (One Pulse) Plot on Channel 39

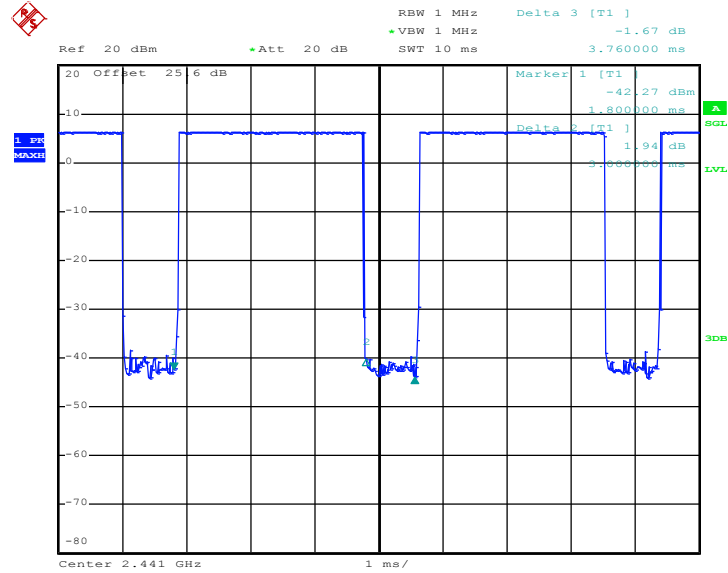

Date: 7.SEP.2012 20:54:30

DH5 Dwell Time (Count Pulses) Plot on Channel 39

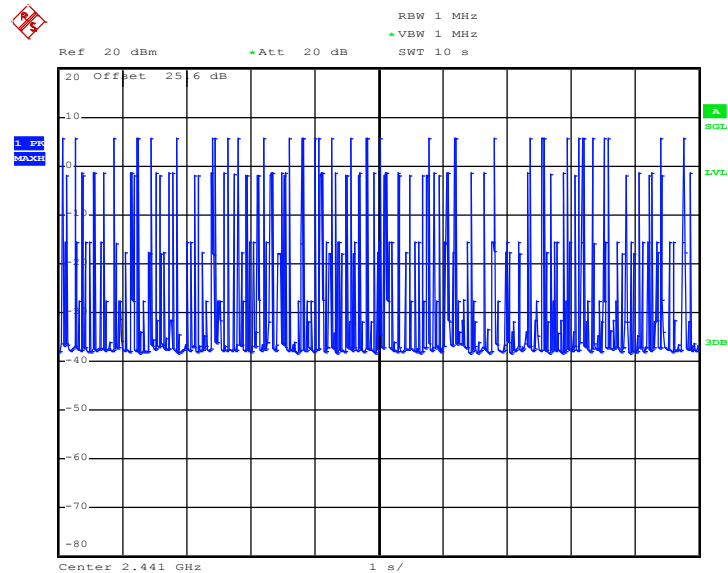

Date: 21.SEP.2012 17:29:29

3.4 20dB Bandwidth Measurement

3.4.1 Limit of 20dB Bandwidth

Reporting only

3.4.2 Measuring Instruments

See list of measuring instruments of this test report.

3.4.3 Test Procedures

1. The testing follows FCC Public Notice DA 00-705 Measurement Guidelines.
2. The RF output of EUT was connected to the spectrum analyzer by a low loss cable.
3. Set to the maximum power setting and enable the EUT transmit continuously.
4. Use the following spectrum analyzer settings:
Span = approximately 2 to 3 times the 20 dB bandwidth, centered on a hopping channel;
RBW \geq 1% of the 20 dB bandwidth; VBW \geq RBW; Sweep = auto; Detector function = peak;
Trace = max hold.

3.4.4 Test Setup

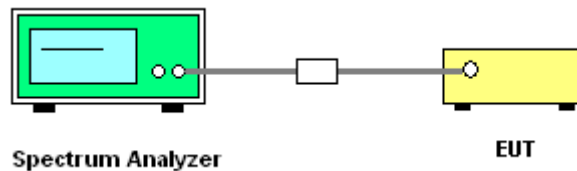

3.4.5 Test Result of 20dB Bandwidth

Test Mode :	1Mbps	Temperature :	24~26°C
Test Engineer :	Book Lin	Relative Humidity :	50~53%

Channel	Frequency (MHz)	20dB Bandwidth (MHz)
00	2402	0.904
39	2441	0.904
78	2480	0.904

20 dB Bandwidth Plot on Channel 00

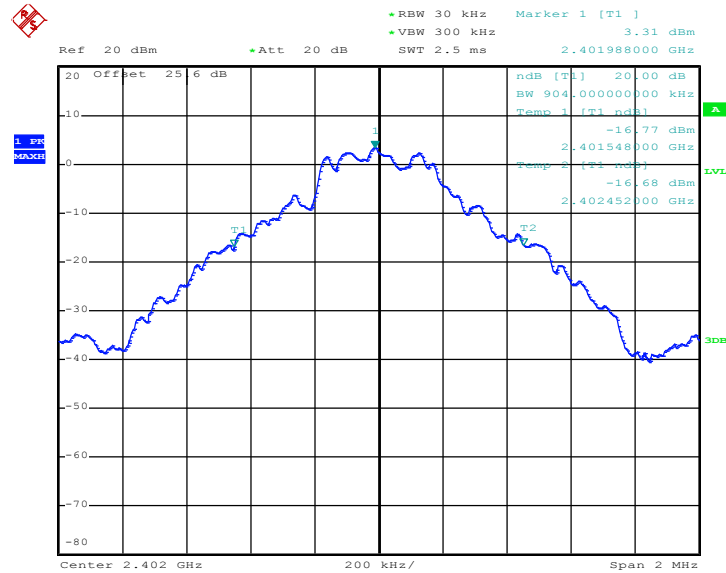

Date: 21.SEP.2012 16:55:20



20 dB Bandwidth Plot on Channel 39

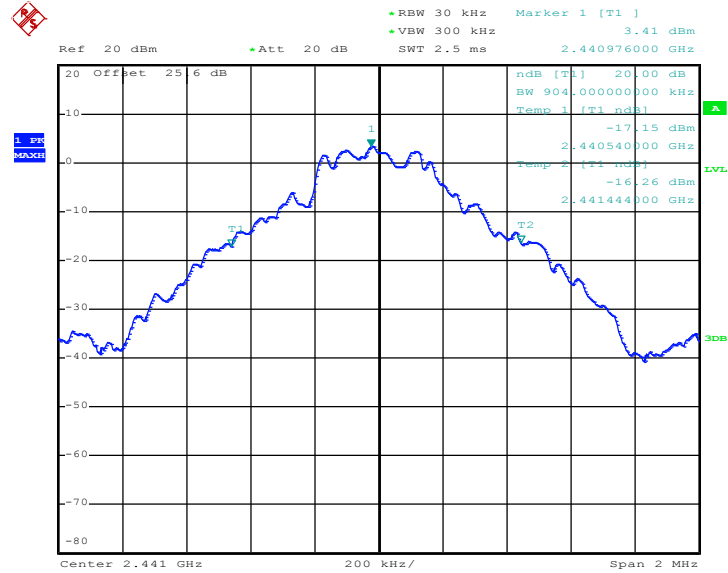

Date: 21.SEP.2012 16:55:39

20 dB Bandwidth Plot on Channel 78

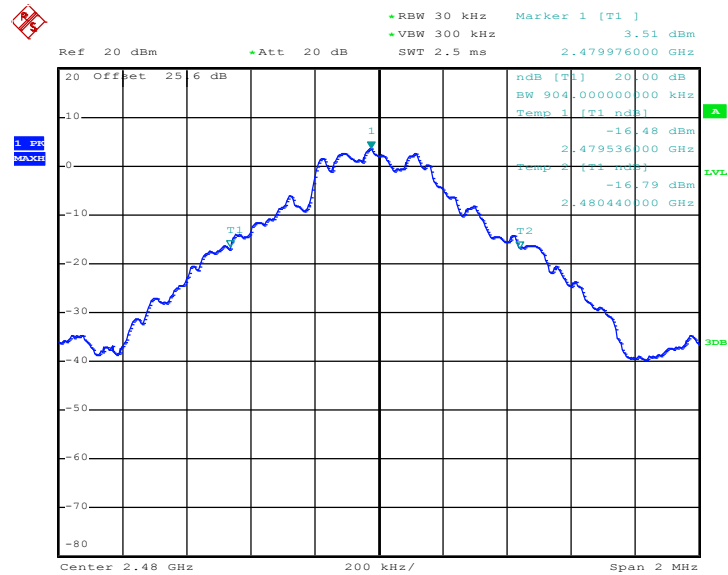

Date: 21.SEP.2012 16:56:17



Test Mode :	2Mbps	Temperature :	24~26°C
Test Engineer :	Book Lin	Relative Humidity :	50~53%

Channel	Frequency (MHz)	20dB Bandwidth (MHz)
00	2402	1.344
39	2441	1.350
78	2480	1.344

20 dB Bandwidth Plot on Channel 00

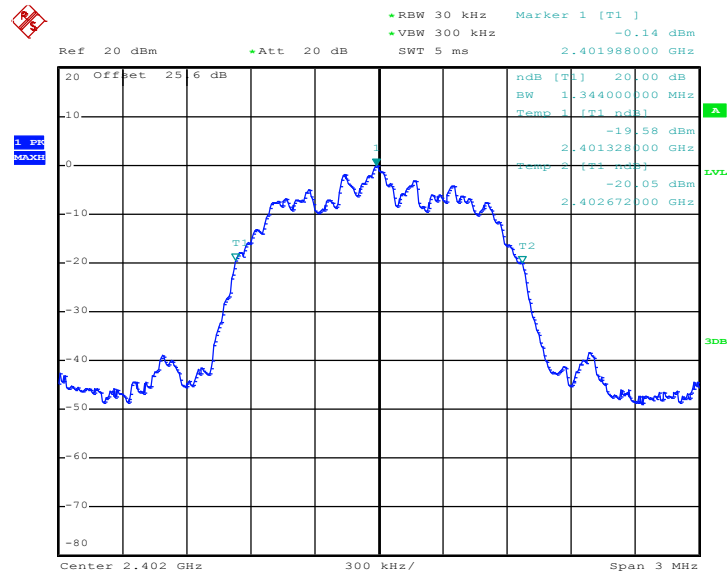

Date: 21.SEP.2012 16:56:50



20 dB Bandwidth Plot on Channel 39

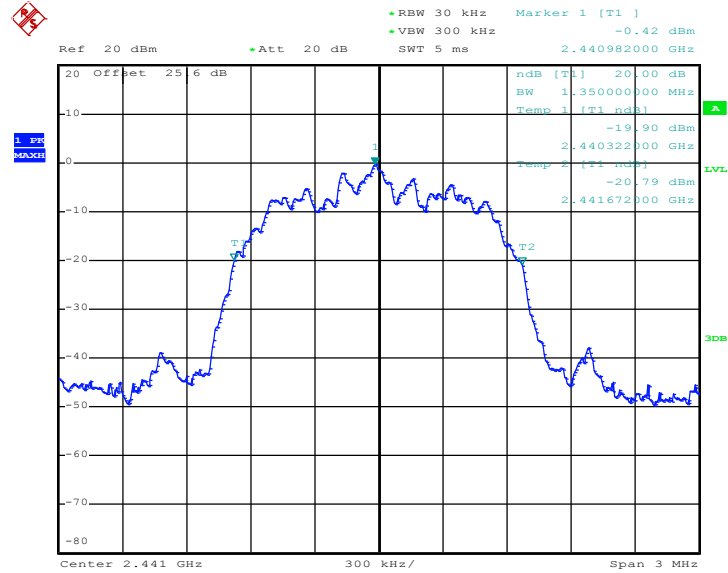

Date: 21.SEP.2012 16:57:20

20 dB Bandwidth Plot on Channel 78

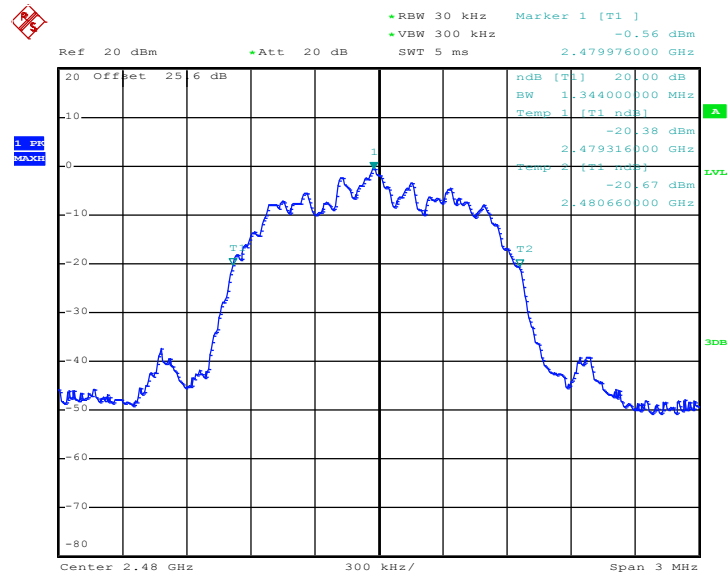

Date: 21.SEP.2012 16:57:58



Test Mode :	3Mbps	Temperature :	24~26°C
Test Engineer :	Book Lin	Relative Humidity :	50~53%

Channel	Frequency (MHz)	20dB Bandwidth (MHz)
00	2402	1.296
39	2441	1.290
78	2480	1.290

20 dB Bandwidth Plot on Channel 00

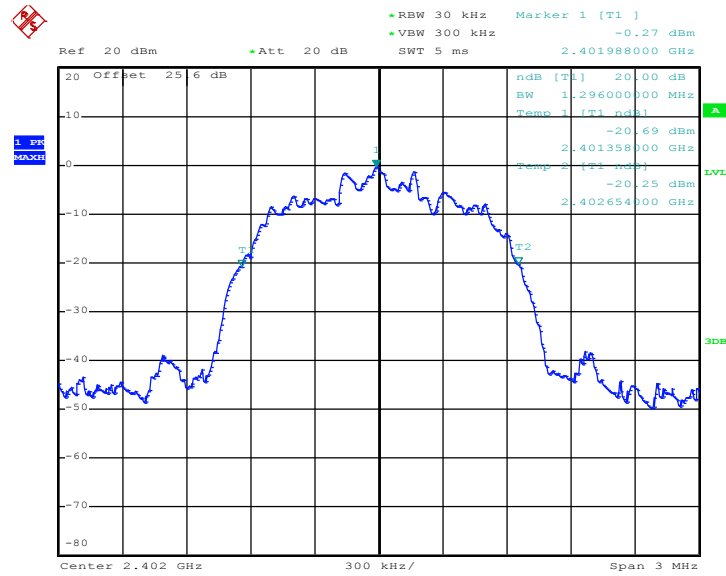

Date: 21.SEP.2012 16:58:27



20 dB Bandwidth Plot on Channel 39

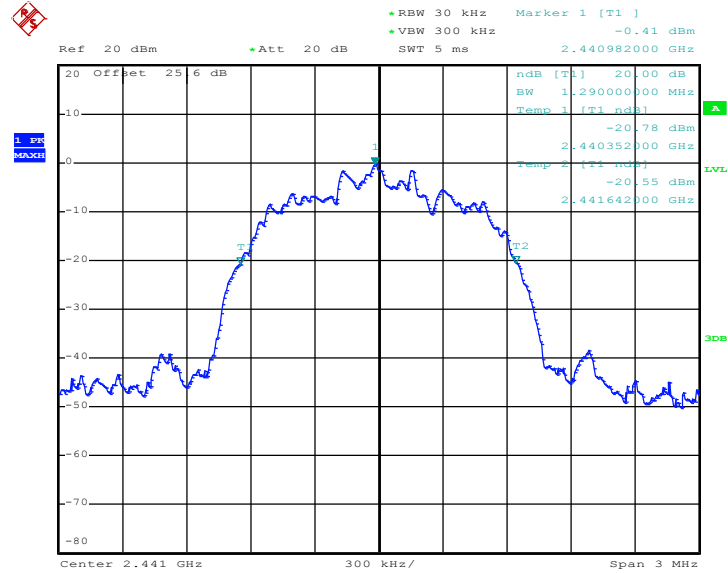

Date: 21.SEP.2012 16:58:58

20 dB Bandwidth Plot on Channel 78

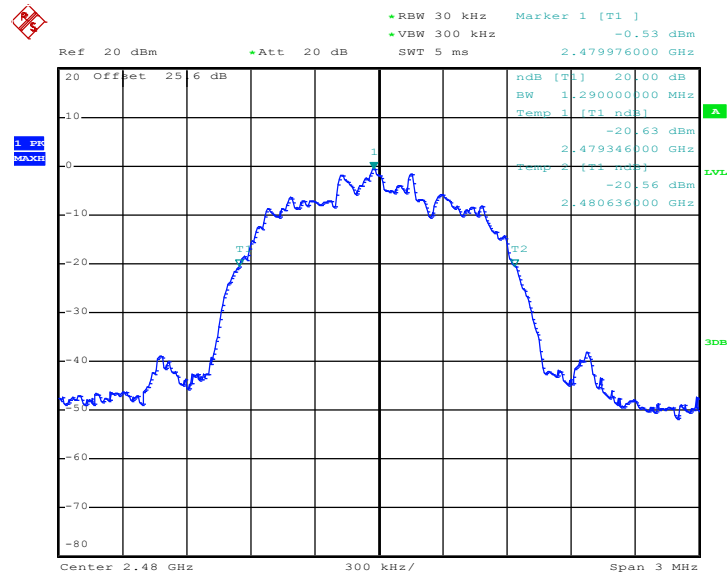

Date: 21.SEP.2012 16:59:30

3.5 Peak Output Power Measurement

3.5.1 Limit of Peak Output Power

Section 15.247 (b) The maximum peak conducted output power of the intentional radiator shall not exceed the following: (1) For frequency hopping systems operating in the 2400-2483.5 MHz band employing at least 75 non-overlapping hopping channels, and all frequency hopping systems in the 5725-5850 MHz band: 1 watt. For all other frequency hopping systems in the 2400-2483.5 MHz band 0.125 watts. The power limit for 1Mbps is 1watt, and for 2Mbps, and 3Mbps are 0.125 watts.

3.5.2 Measuring Instruments

See list of measuring instruments of this test report.

3.5.3 Test Procedures

1. The testing follows FCC Public Notice DA 00-705 Measurement Guidelines.
2. The RF output of EUT was connected to the spectrum analyzer by a low loss cable.
3. Set to the maximum power setting and enable the EUT transmit continuously.
4. Measure the conducted output power and record the results in the test report.

3.5.4 Test Setup

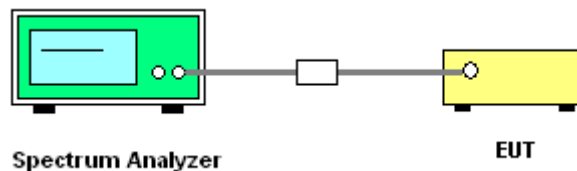



3.5.5 Test Result of Peak Output Power

Test Mode :	1Mbps	Temperature :	24~26°C
Test Engineer :	Book Lin	Relative Humidity :	50~53%

Channel	Frequency (MHz)	RF Power (dBm)		
		GFSK	Max. Limits (dBm)	Pass/Fail
		1 Mbps		
00	2402	6.50	30.00	Pass
39	2441	6.32	30.00	Pass
78	2480	6.26	30.00	Pass

Peak Output Power Plot on Channel 00

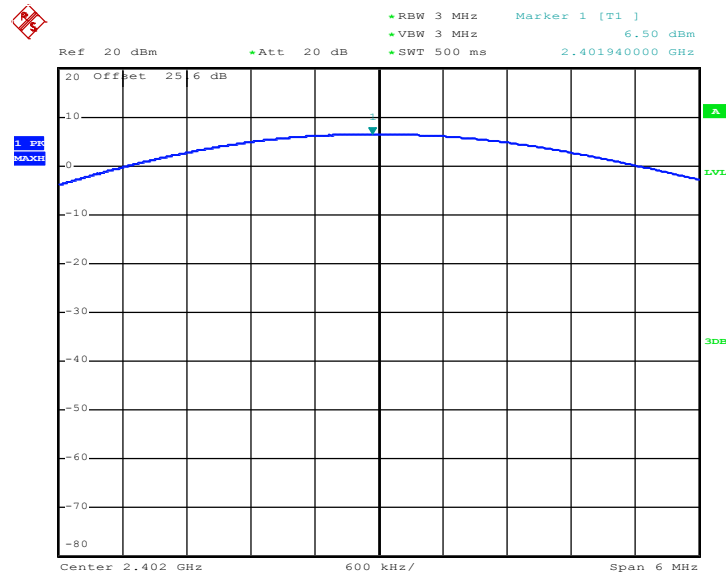

Date: 7.SEP.2012 20:52:10



Peak Output Power Plot on Channel 39

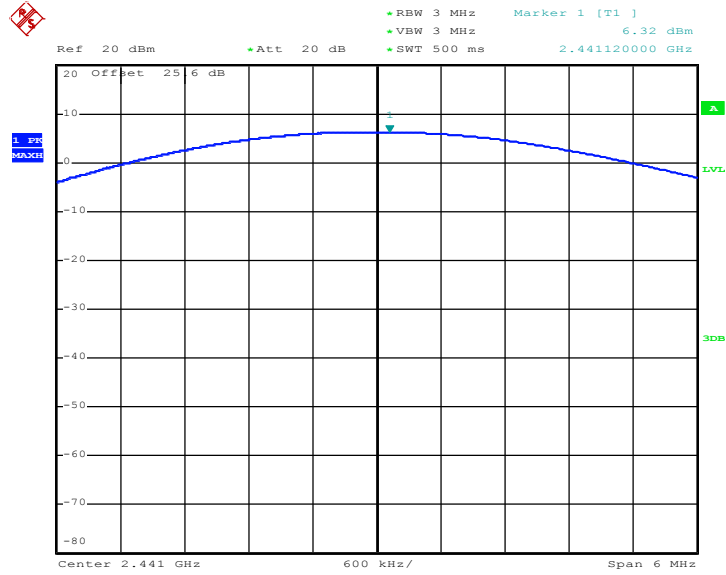

Date: 7.SEP.2012 20:44:54

Peak Output Power Plot on Channel 78

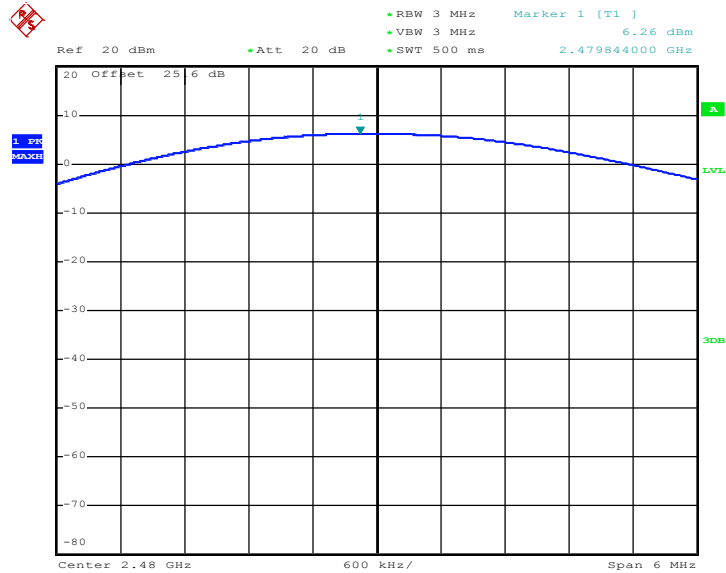

Date: 7.SEP.2012 20:46:09



Test Mode :	2Mbps	Temperature :	24~26°C
Test Engineer :	Book Lin	Relative Humidity :	50~53%

Channel	Frequency (MHz)	RF Power (dBm)		
		$\pi/4$ -DQPSK	Max. Limits (dBm)	Pass/Fail
		2 Mbps		
00	2402	5.01	20.97	Pass
39	2441	4.88	20.97	Pass
78	2480	4.77	20.97	Pass

Peak Output Power Plot on Channel 00

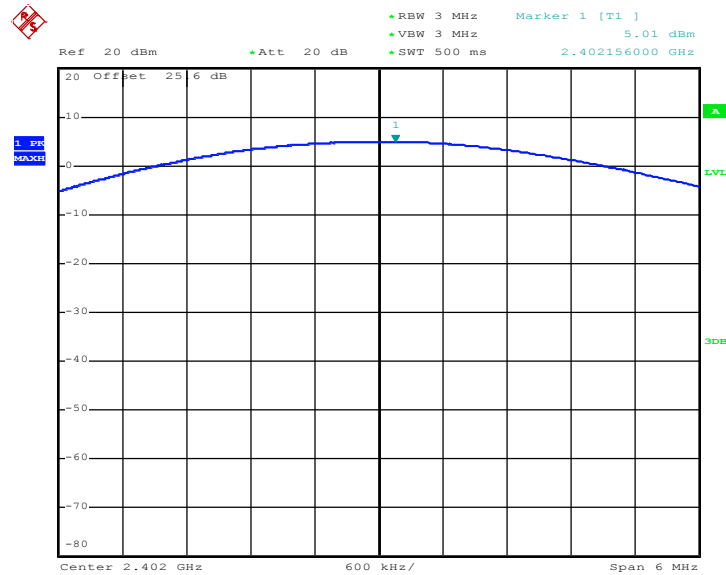

Date: 7.SEP.2012 20:44:04



Peak Output Power Plot on Channel 39

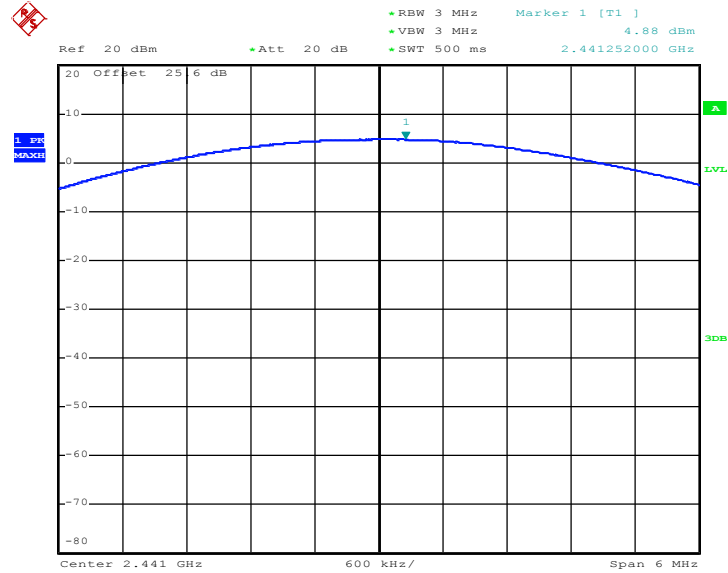

Date: 7.SEP.2012 20:45:19

Peak Output Power Plot on Channel 78

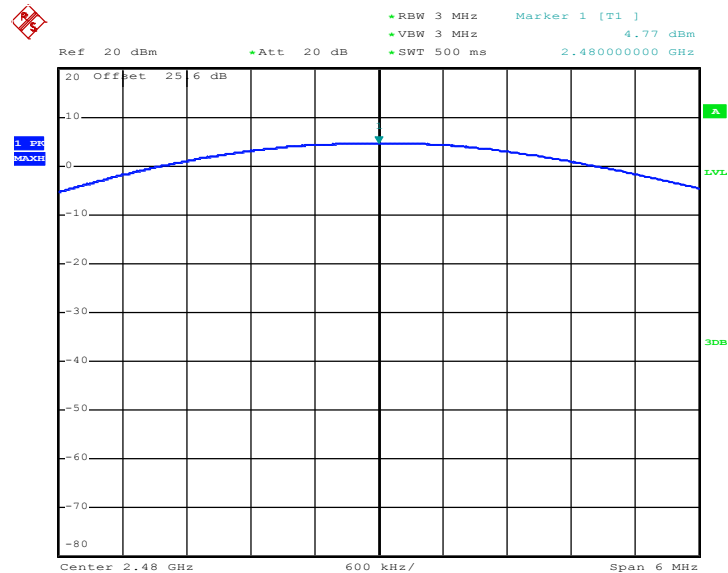

Date: 7.SEP.2012 20:46:35



Test Mode :	3Mbps	Temperature :	24~26°C
Test Engineer :	Book Lin	Relative Humidity :	50~53%

Channel	Frequency (MHz)	RF Power (dBm)		
		8-DPSK	Max. Limits (dBm)	Pass/Fail
		3 Mbps		
00	2402	5.49	20.97	Pass
39	2441	5.37	20.97	Pass
78	2480	5.34	20.97	Pass

Peak Output Power Plot on Channel 00

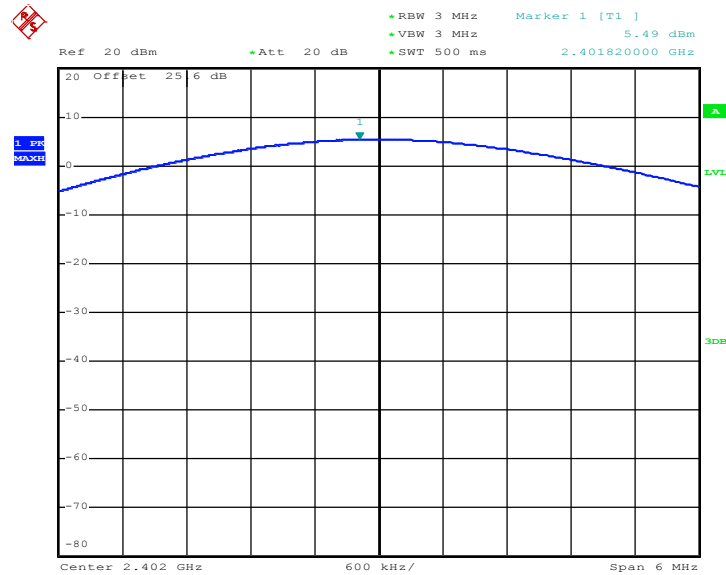

Date: 7.SEP.2012 20:44:29



Peak Output Power Plot on Channel 39

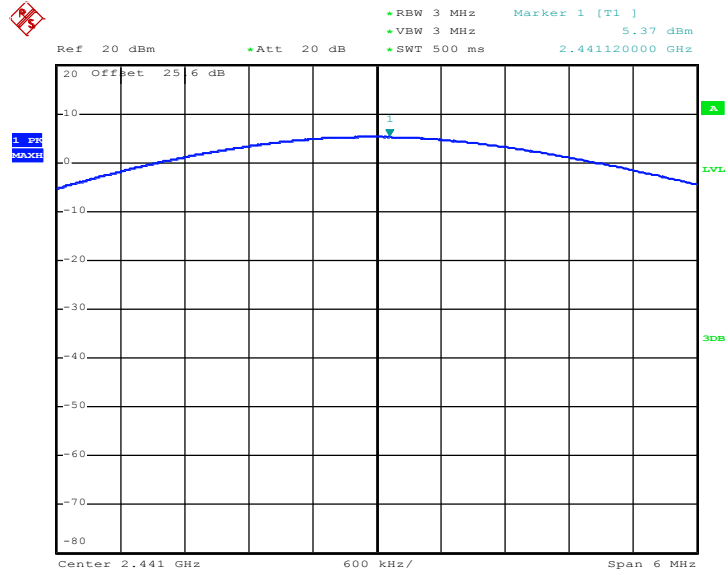

Date: 7.SEP.2012 20:45:44

Peak Output Power Plot on Channel 78

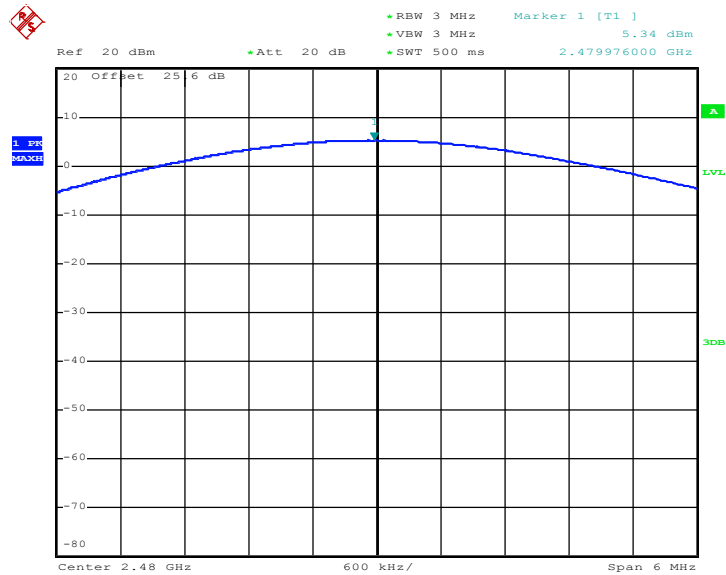

Date: 7.SEP.2012 20:47:00

3.6 Conducted Band Edges Measurement

3.6.1 Limit of Band Edges

In any 100 KHz bandwidth outside the intentional radiation frequency band, the radio frequency power shall be at least 20 dB below the highest level of the radiated power. In addition, radiated emissions which fall in the restricted bands must also comply with the radiated emission limits.

3.6.2 Measuring Instruments

See list of measuring instruments of this test report.

3.6.3 Test Procedures

1. The testing follows the guidelines in Band-edge Compliance of RF Conducted Emissions of FCC Public Notice DA 00-705 Measurement Guidelines.
2. Set to the maximum power setting and enable the EUT transmit continuously.
3. Set RBW = 300KHz ($\geq 1\%$ span=30MHz), VBW = 300KHz (\geq RBW). Band edge emissions must be at least 20 dB down from the highest emission level within the authorized band as measured with a 300KHz RBW. The attenuation shall be 30 dB instead of 20 dB when RMS conducted output power procedure is used.
4. Enable hopping function of the EUT and then repeat step 2. and 3.
5. Record the results in the test report.

3.6.4 Test Setup

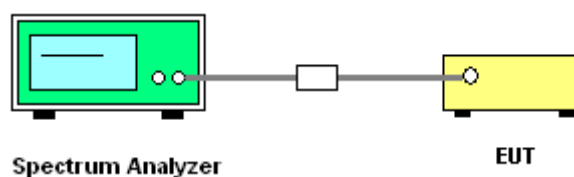



3.6.5 Test Result of Conducted Band Edges

Test Mode :	1Mbps	Temperature :	24~26°C
Test Channel :	00 and 78	Relative Humidity :	50~53%
		Test Engineer :	Book Lin

Low Band Edge Plot on Channel 00

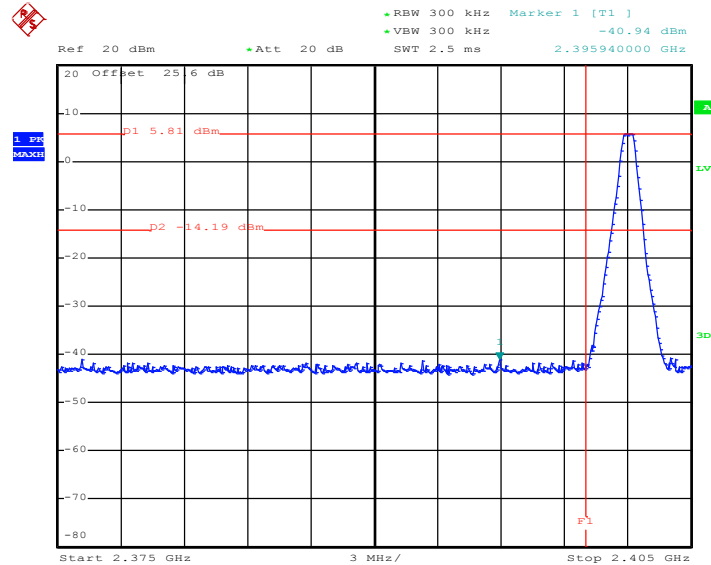

Date: 21.SEP.2012 17:00:24

High Band Edge Plot on Channel 78

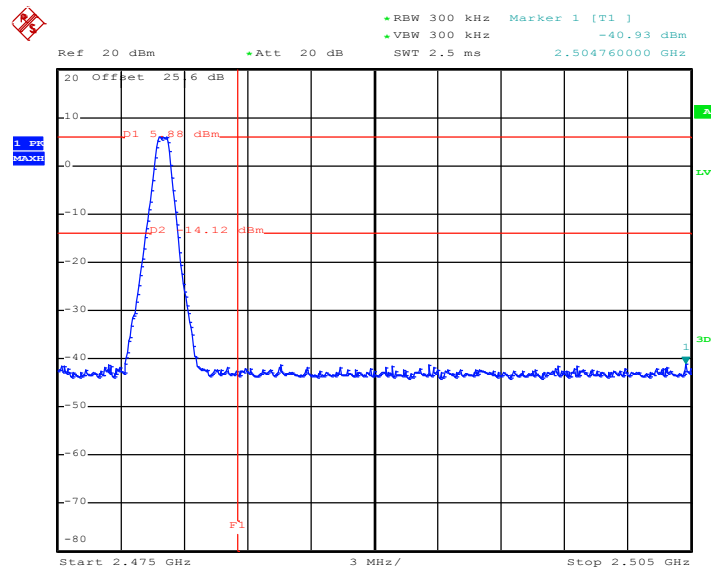

Date: 21.SEP.2012 17:01:27



3.6.6 Test Result of Conducted Hopping Mode Band Edges

Test Mode :	1Mbps	Temperature :	24~26°C
Test Engineer :	Book Lin	Relative Humidity :	50~53%

Hopping Mode Low Band Edge Plot

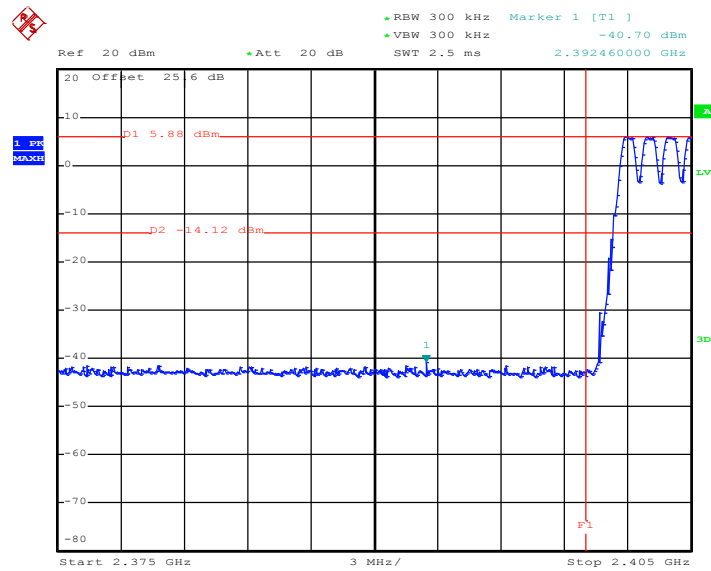

Date: 21.SEP.2012 18:49:49

Hopping Mode High Band Edge Plot

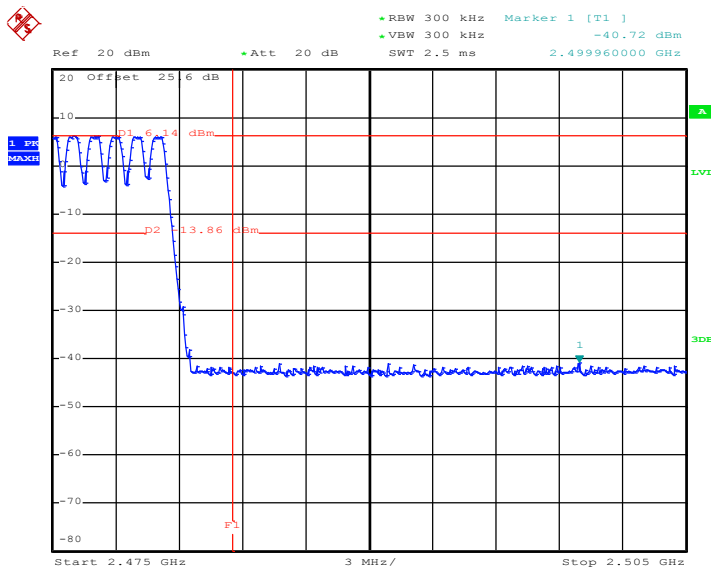

Date: 21.SEP.2012 19:24:54

3.7 Conducted Spurious Emission Measurement

3.7.1 Limit of Spurious Emission Measurement

In any 100 KHz bandwidth outside the intentional radiation frequency band, the radio frequency power shall be at least 20 dB below the highest level of the radiated power. In addition, radiated emissions which fall in the restricted bands must also comply with the radiated emission limits.

3.7.2 Measuring Instruments

See list of measuring instruments of this test report.

3.7.3 Test Procedure

1. The testing follows the guidelines in Spurious RF Conducted Emissions of FCC Public Notice DA 00-705 Measurement Guidelines
2. The transmitter output was connected to the spectrum analyzer via a low loss cable.
3. Set to the maximum power setting and enable the EUT transmit continuously.
4. Set RBW = 100 KHz, VBW = 300KHz, scan up through 10th harmonic. All harmonics / spurs must be at least 20 dB down from the highest emission level within the authorized band as measured with a 100 KHz RBW.
5. Record the results in the test report.

3.7.4 Test Setup

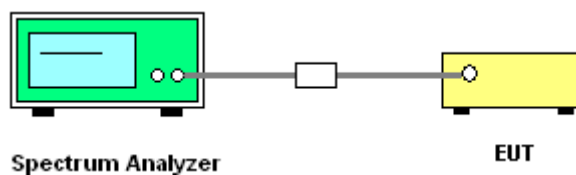

3.7.5 Test Result

Test Mode :	1Mbps	Temperature :	24~26°C
Test Channel :	00	Relative Humidity :	50~53%
		Test Engineer :	Book Lin

Conducted Spurious Emission Plot between 30MHz ~ 3 GHz

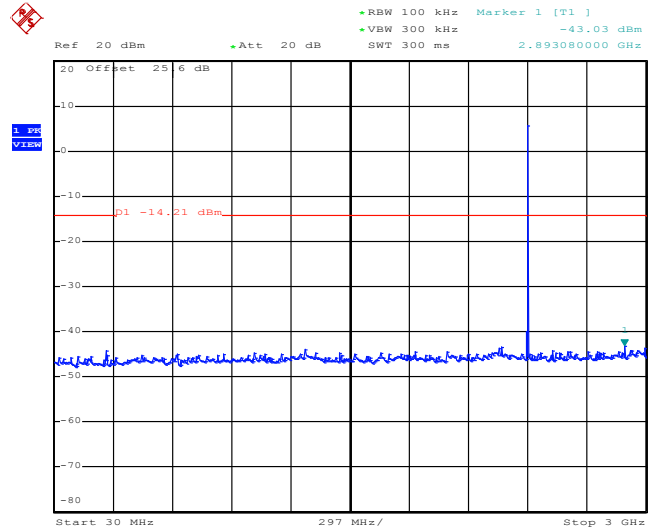

Date: 21.SEP.2012 17:11:36

Conducted Spurious Emission Plot between 2 GHz ~ 25 GHz

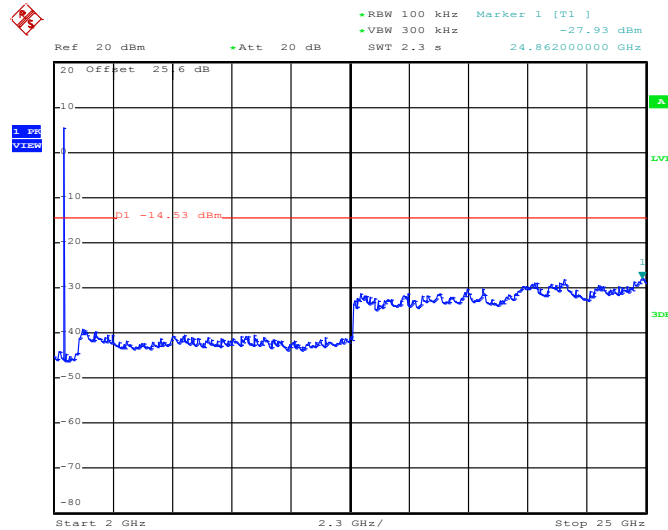

Date: 21.SEP.2012 17:12:28



Test Mode :	3Mbps	Temperature :	24~26°C
Test Channel :	39	Relative Humidity :	50~53%
		Test Engineer :	Book Lin

Conducted Spurious Emission Plot between 30MHz ~ 3 GHz

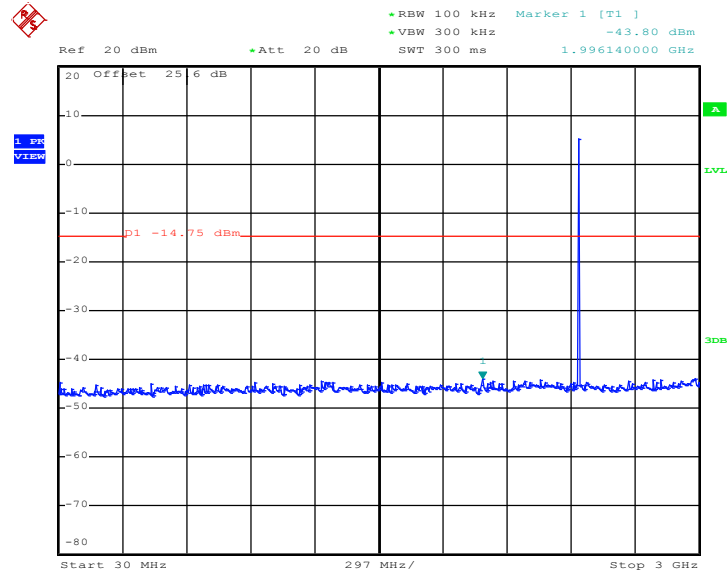

Date: 21.SEP.2012 17:13:21

Conducted Spurious Emission Plot between 2 GHz ~ 25 GHz

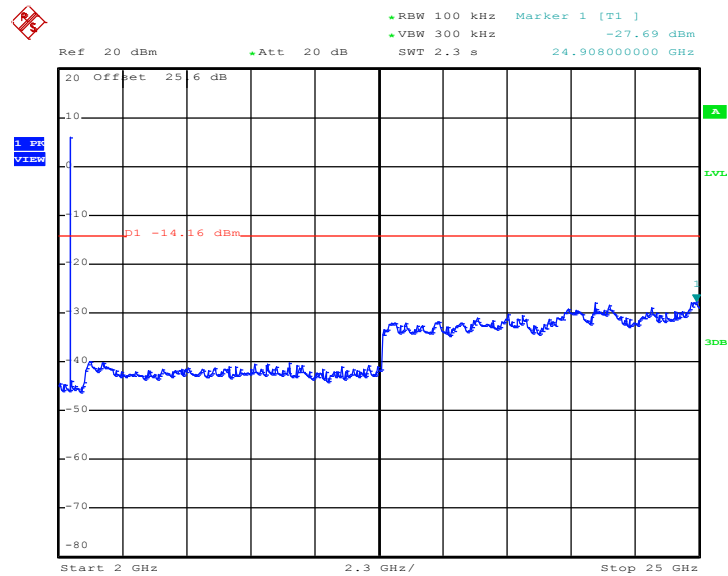

Date: 21.SEP.2012 17:14:13



Test Mode :	3Mbps	Temperature :	24~26°C
Test Channel :	78	Relative Humidity :	50~53%
		Test Engineer :	Book Lin

Conducted Spurious Emission Plot between 30MHz ~ 3 GHz

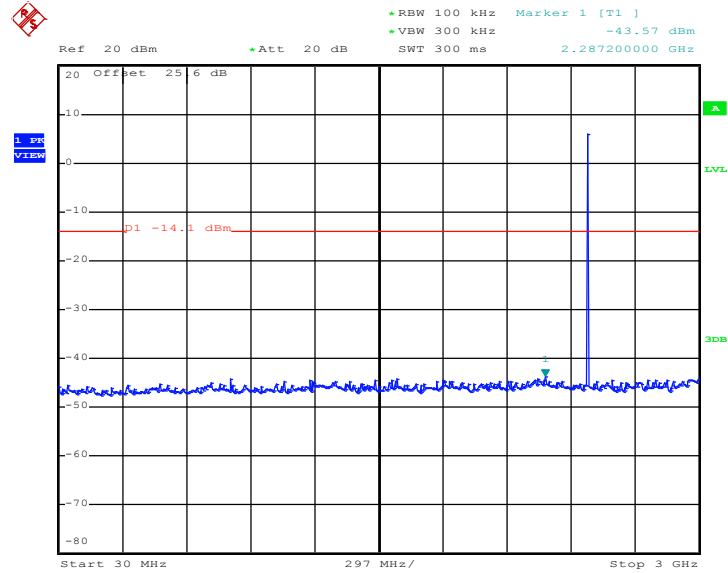

Date: 21.SEP.2012 17:15:05

Conducted Spurious Emission Plot between 2 GHz ~ 25 GHz

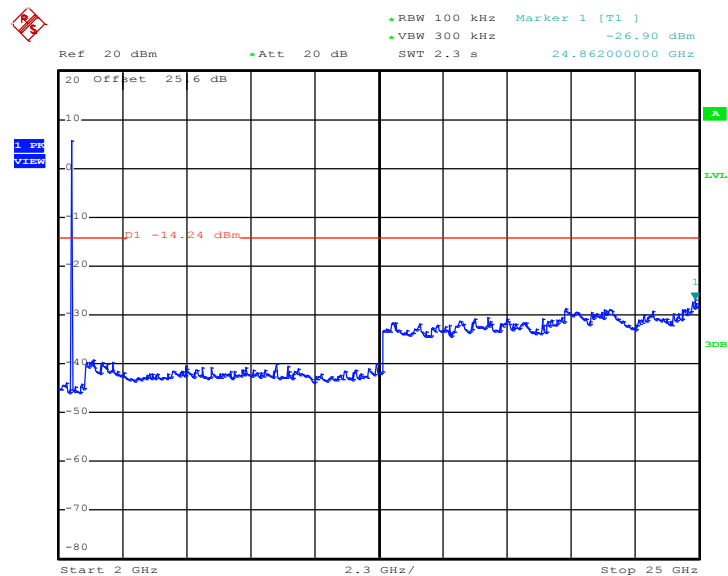

Date: 21.SEP.2012 17:15:57

3.8 Radiated Band Edges and Spurious Emission Measurement

3.8.1 Limit of Radiated Band Edges and Spurious Emission

In any 100 KHz bandwidth outside the intentional radiator frequency band, all harmonics/spurious must be at least 20 dB below the highest emission level within the authorized band. In addition, radiated emissions which fall in the restricted bands must also comply with the FCC section 15.209 limits as below.

Frequency (MHz)	Field Strength (microvolts/meter)	Measurement Distance (meters)
0.009 – 0.490	2400/F(KHz)	300
0.490 – 1.705	24000/F(KHz)	30
1.705 – 30.0	30	30
30 – 88	100	3
88 – 216	150	3
216 - 960	200	3
Above 960	500	3

3.8.2 Measuring Instruments

See list of measuring instruments of this test report.



3.8.3 Test Procedures

1. The testing follows the guidelines in Spurious Radiated Emissions of FCC Public Notice DA 00-705 Measurement Guidelines and fulfills ANSI C63.4-2003 and the guidelines in ANSI C63.10-2009 test site requirement.
2. The EUT was placed on a turntable with 0.8 meter above ground.
3. The EUT was set 3 meters from the interference receiving antenna, which was mounted on the top of a variable height antenna tower.
4. For each suspected emission, the EUT was arranged to its worst case and then tune the Antenna tower (from 1 m to 4 m) and turntable (from 0 degree to 360 degrees) to find the maximum reading. A pre-amp and a high pass filter are used for the test in order to get better signal level to comply with the guidelines.
5. Set to the maximum power setting and enable the EUT transmit continuously.
6. Use the following spectrum analyzer settings:
 - (1) Span shall wide enough to fully capture the emission being measured;
 - (2) Set RBW=100 KHz for $f < 1 \text{ GHz}$, RBW=1MHz for $f > 1 \text{ GHz}$; VBW \geq RBW; Sweep = auto; Detector function = peak; Trace = max hold for peak
 - (3) For average measurement: use duty cycle correction factor method per 15.35(c).
Duty cycle = On time/100 milliseconds
On time = $N_1 * L_1 + N_2 * L_2 + \dots + N_{n-1} * L_{n-1} + N_n * L_n$
Where N_1 is number of type 1 pulses, L_1 is length of type 1 pulses, etc.
Average Level = Peak Level + $20 * \log(\text{Duty cycle})$
7. Corrected Reading: Antenna Factor + Cable Loss + Read Level - Preamp Factor = Level

Note: The average levels were calculated from the peak level corrected with duty cycle correction factor (24.76dB) derived from $20 \log(\text{dwell time}/100\text{ms})$.

For example: Average level = $50\text{dBuV/m} - 24.76 \text{ (dB)} = 25.24\text{dBuV/m}$.

3.8.4 Test Setup

For radiated emissions below 30MHz

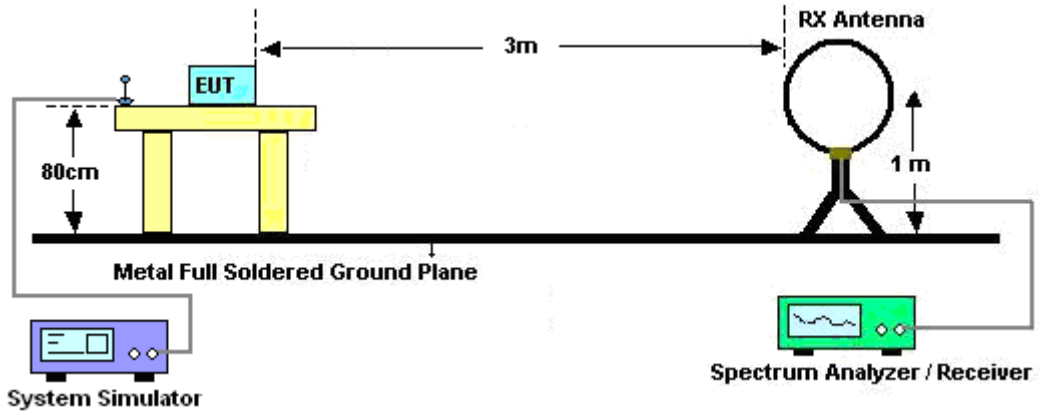

For radiated emissions from 30MHz to 1GHz

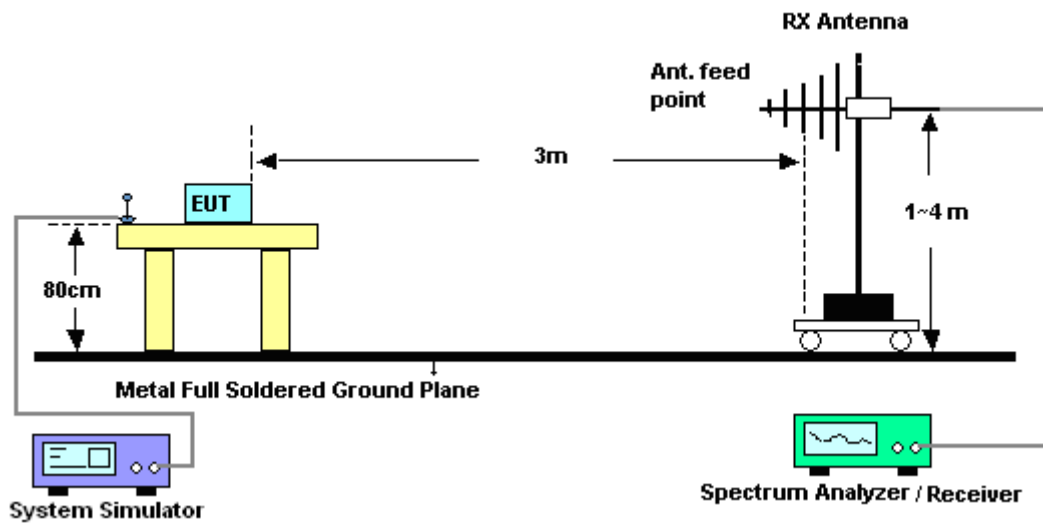

For radiated emissions above 1GHz

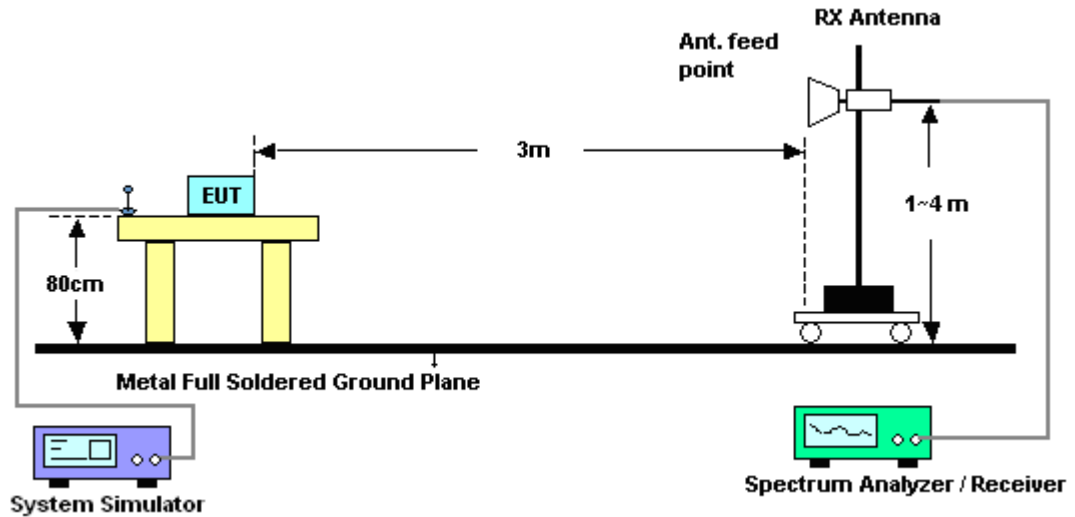

3.8.5 Test Results of Radiated Emissions (9 KHz ~ 30 MHz)

The low frequency, which started from 9 KHz to 30MHz, was pre-scanned and the result which was 20dB lower than the limit line per 15.31(o) was not reported.

3.8.6 Duty cycle correction factor for average measurement

DH5 on time/100ms (One Pulse) Plot on Channel 39

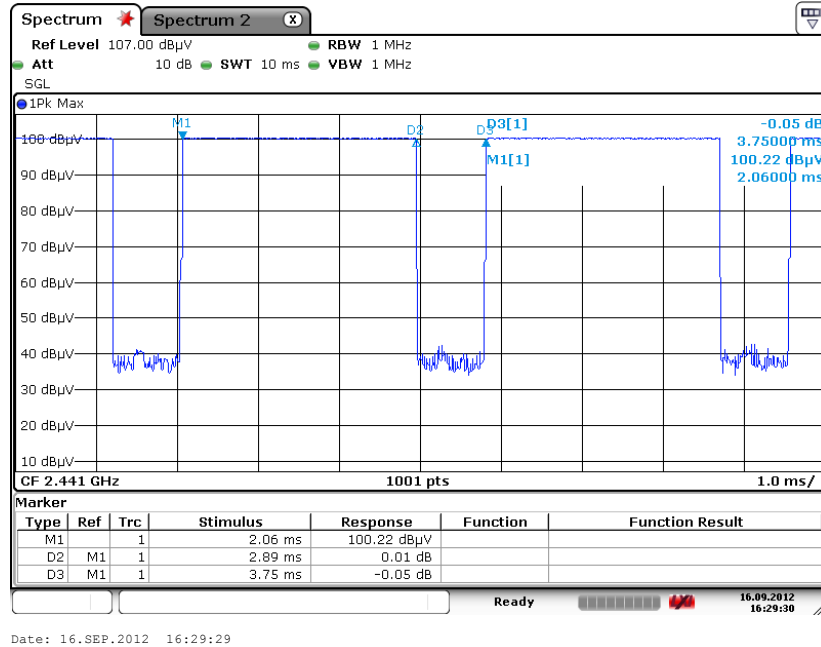

DH5 on time/100ms (Count Pulses) Plot on Channel 39

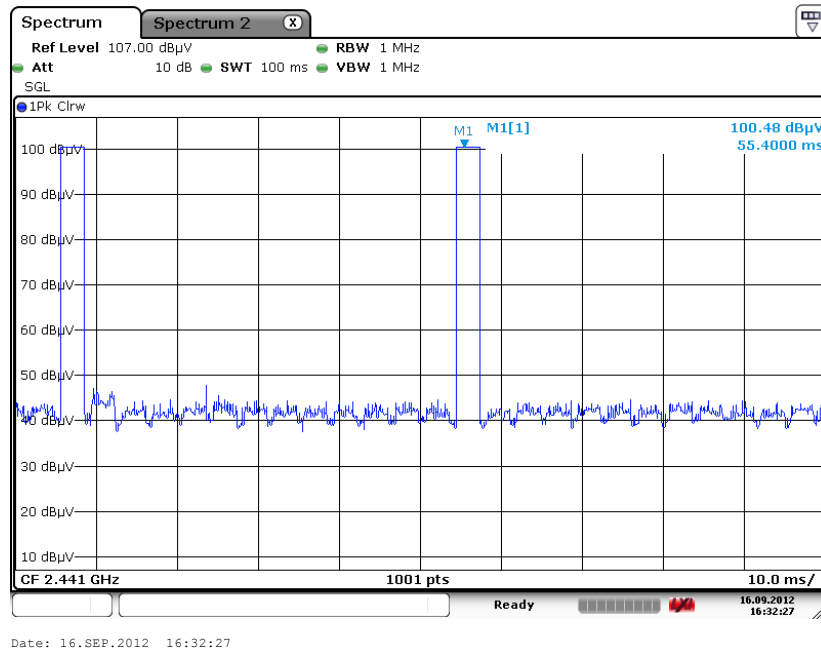

Note:

1. Duty cycle = on time/100 milliseconds = 2 * 2.890 / 100 = 5.78 %
2. Duty cycle correction factor = 20*log(Duty cycle) = -24.76 dB
3. DH5 has the highest duty cycle and is reported.



3.8.7 Test Result of Radiated Band Edges

Test Mode :	1Mbps	Temperature :	30~31°C
Test Channel :	00	Relative Humidity :	42~43%
		Test Engineer :	Kai Wang, Timberland Lin and Ivan Chiang

ANTENNA POLARITY : HORIZONTAL										
Frequency (MHz)	Level (dBμV/m)	Over Limit (dB)	Limit Line (dBμV/m)	Read Level (dBμV)	Antenna Factor (dB)	Cable Loss (dB)	Preamp Factor (dB)	Ant Pos (cm)	Table Pos (deg)	Remark
2364.63	50	-24	74	45.83	32.31	6.42	34.56	110	62	Peak
2364.63	25.24	-28.76	54	-	-	-	-	-	-	Average

ANTENNA POLARITY : VERTICAL										
Frequency (MHz)	Level (dBμV/m)	Over Limit (dB)	Limit Line (dBμV/m)	Read Level (dBμV)	Antenna Factor (dB)	Cable Loss (dB)	Preamp Factor (dB)	Ant Pos (cm)	Table Pos (deg)	Remark
2359.05	47.7	-26.3	74	43.53	32.31	6.42	34.56	100	292	Peak
2359.05	22.94	-31.06	54	-	-	-	-	-	-	Average

Note: The average levels were calculated from the peak level corrected with duty cycle correction factor (24.76dB) derived from 20log (dwell time/100ms).

For example: Average level = 50dBuV/m – 24.76 (dB) = 25.24dBuV/m.

Test Mode :	1Mbps	Temperature :	30~31°C
Test Channel :	78	Relative Humidity :	42~43%
		Test Engineer :	Kai Wang, Timberland Lin and Ivan Chiang

ANTENNA POLARITY : HORIZONTAL										
Frequency (MHz)	Level (dBμV/m)	Over Limit (dB)	Limit Line (dBμV/m)	Read Level (dBμV)	Antenna Factor (dB)	Cable Loss (dB)	Preamp Factor (dB)	Ant Pos (cm)	Table Pos (deg)	Remark
2483.6	49.36	-24.64	74	44.84	32.48	6.59	34.55	105	62	Peak
2483.6	24.6	-29.4	54	-	-	-	-	-	-	Average

ANTENNA POLARITY : VERTICAL										
Frequency (MHz)	Level (dBμV/m)	Over Limit (dB)	Limit Line (dBμV/m)	Read Level (dBμV)	Antenna Factor (dB)	Cable Loss (dB)	Preamp Factor (dB)	Ant Pos (cm)	Table Pos (deg)	Remark
2483.92	49.09	-24.91	74	44.57	32.48	6.59	34.55	100	259	Peak
2483.92	24.33	-29.67	54	-	-	-	-	-	-	Average



3.8.8 Test Result of Radiated Emission (30 MHz ~ 10th Harmonic)

Test Mode :	1Mbps	Temperature :	30~31°C
Test Channel :	00	Relative Humidity :	42~43%
Test Engineer :	Kai Wang, Timberland Lin and Ivan Chiang	Polarization :	Horizontal
Remark :	1. 2402 MHz is fundamental signal which can be ignored. 2. Test result of emissions which are 20 dB lower than the limit is not reported per15.31.		

Frequency (MHz)	Level (dBμV/m)	Over Limit (dB)	Limit Line (dBμV/m)	Read Level (dBμV)	Antenna Factor (dB)	Cable Loss (dB)	Preamp Factor (dB)	Ant Pos (cm)	Table Pos (deg)	Remark
52.95	24.14	-15.86	40	47.67	7.5	0.66	31.69	-	-	Peak
144.75	28.88	-14.62	43.5	48.36	10.77	1.45	31.7	-	-	Peak
208.2	31.69	-11.81	43.5	52.48	8.97	1.87	31.63	100	139	Peak
417.6	18.9	-27.1	46	31.84	16.46	2.43	31.83	-	-	Peak
616.4	21.93	-24.07	46	31.81	19.04	3.16	32.08	-	-	Peak
949.6	25.48	-20.52	46	31.88	20.9	3.83	31.13	-	-	Peak
2402	104.74	-	-	100.49	32.36	6.45	34.56	110	62	Peak
2402	79.98	-	-	-	-	-	-	-	-	Average

Note: The average levels were calculated from the peak level corrected with duty cycle correction factor (24.76dB) derived from 20log (dwell time/100ms).

For example: Average level = 104.74dBuV/m – 24.76 (dB) = 79.98dBuV/m.



Test Mode :	1Mbps	Temperature :	30~31°C
Test Channel :	00	Relative Humidity :	42~43%
Test Engineer :	Kai Wang, Timberland Lin and Ivan Chiang	Polarization :	Vertical
Remark :	1. 2402 MHz is fundamental signal which can be ignored. 2. Test result of emissions which are 20 dB lower than the limit is not reported per15.31.		

Frequency (MHz)	Level (dBμV/m)	Over Limit (dB)	Limit Line (dBμV/m)	Read Level (dBμV)	Antenna Factor (dB)	Cable Loss (dB)	Preamp Factor (dB)	Ant Pos (cm)	Table Pos (deg)	Remark
30.27	31.35	-8.65	40	43.87	18.8	0.4	31.72	-	-	Peak
48.36	33.74	-6.26	40	55.95	8.87	0.63	31.71	100	125	Peak
108.84	28.75	-14.75	43.5	47.59	11.76	1.11	31.71	-	-	Peak
371.4	16.53	-29.47	46	31.03	14.82	2.34	31.66	-	-	Peak
699	21.57	-24.43	46	31.04	18.99	3.55	32.01	-	-	Peak
926.5	24.07	-21.93	46	30.92	20.7	3.79	31.34	-	-	Peak
2402	103.4	-	-	99.15	32.36	6.45	34.56	100	292	Peak
2402	78.64	-	-	-	-	-	-	-	-	Average



Test Mode :	1Mbps	Temperature :	30~31°C
Test Channel :	39	Relative Humidity :	42~43%
Test Engineer :	Kai Wang, Timberland Lin and Ivan Chiang	Polarization :	Horizontal
Remark :	1. 2441 MHz is fundamental signal which can be ignored. 2. Test result of emissions which are 20 dB lower than the limit is not reported per15.31.		

Frequency (MHz)	Level (dBμV/m)	Over Limit (dB)	Limit Line (dBμV/m)	Read Level (dBμV)	Antenna Factor (dB)	Cable Loss (dB)	Preamp Factor (dB)	Ant Pos (cm)	Table Pos (deg)	Remark
2441	104.68	-	-	100.29	32.43	6.52	34.56	100	62	Peak
2441	79.92	-	-	-	-	-	-	-	-	Average

Test Mode :	1Mbps	Temperature :	30~31°C
Test Channel :	39	Relative Humidity :	42~43%
Test Engineer :	Kai Wang, Timberland Lin and Ivan Chiang	Polarization :	Vertical
Remark :	1. 2441 MHz is fundamental signal which can be ignored. 2. Test result of emissions which are 20 dB lower than the limit is not reported per15.31.		

Frequency (MHz)	Level (dBμV/m)	Over Limit (dB)	Limit Line (dBμV/m)	Read Level (dBμV)	Antenna Factor (dB)	Cable Loss (dB)	Preamp Factor (dB)	Ant Pos (cm)	Table Pos (deg)	Remark
2441	102.54	-	-	98.15	32.43	6.52	34.56	100	280	Peak
2441	77.78	-	-	-	-	-	-	-	-	Average



Test Mode :	1Mbps	Temperature :	30~31°C
Test Channel :	78	Relative Humidity :	42~43%
Test Engineer :	Kai Wang, Timberland Lin and Ivan Chiang	Polarization :	Horizontal
Remark :	1. 2480 MHz is fundamental signal which can be ignored. 2. Test result of emissions which are 20 dB lower than the limit is not reported per15.31.		

Frequency (MHz)	Level (dBμV/m)	Over Limit (dB)	Limit Line (dBμV/m)	Read Level (dBμV)	Antenna Factor (dB)	Cable Loss (dB)	Preamp Factor (dB)	Ant Pos (cm)	Table Pos (deg)	Remark
2480	103.71	-	-	99.19	32.48	6.59	34.55	105	62	Peak
2480	78.95	-	-	-	-	-	-	-	-	Average

Test Mode :	1Mbps	Temperature :	30~31°C
Test Channel :	78	Relative Humidity :	42~43%
Test Engineer :	Kai Wang, Timberland Lin and Ivan Chiang	Polarization :	Vertical
Remark :	1. 2480 MHz is fundamental signal which can be ignored. 2. Test result of emissions which are 20 dB lower than the limit is not reported per15.31.		

Frequency (MHz)	Level (dBμV/m)	Over Limit (dB)	Limit Line (dBμV/m)	Read Level (dBμV)	Antenna Factor (dB)	Cable Loss (dB)	Preamp Factor (dB)	Ant Pos (cm)	Table Pos (deg)	Remark
2480	102.4	-	-	97.88	32.48	6.59	34.55	100	259	Peak
2480	77.64	-	-	-	-	-	-	-	-	Average

3.9 AC Conducted Emission Measurement

3.9.1 Limit of AC Conducted Emission

For equipment that is designed to be connected to the public utility (AC) power line, the radio frequency voltage that is conducted back onto the AC power line on any frequency or frequencies within the band 150 KHz to 30 MHz shall not exceed the limits in the following table.

Frequency of emission (MHz)	Conducted limit (dBuV)	
	Quasi-peak	Average
0.15-0.5	66 to 56*	56 to 46*
0.5-5	56	46
5-30	60	50

*Decreases with the logarithm of the frequency.

3.9.2 Measuring Instruments

See list of measuring instruments of this test report.

3.9.3 Test Procedures

1. The test follows the guidelines in ANSI C63.4-2003 and ANSI C63.10-2009 test site requirement.
2. The EUT was placed 0.4 meter from the conducting wall of the shielding room was kept at least 80 centimeters from any other grounded conducting surface.
3. Connect EUT to the power mains through a line impedance stabilization network (LISN).
4. All the support units are connecting to the other LISN.
5. The LISN provides 50 ohm coupling impedance for the measuring instrument.
6. The FCC states that a 50 ohm, 50 microhenry LISN should be used.
7. Both sides of AC line were checked for maximum conducted interference.
8. The frequency range from 150 KHz to 30 MHz was searched.
9. Set the test-receiver system to Peak Detect Function and specified bandwidth with Maximum Hold Mode.

3.9.4 Test Setup

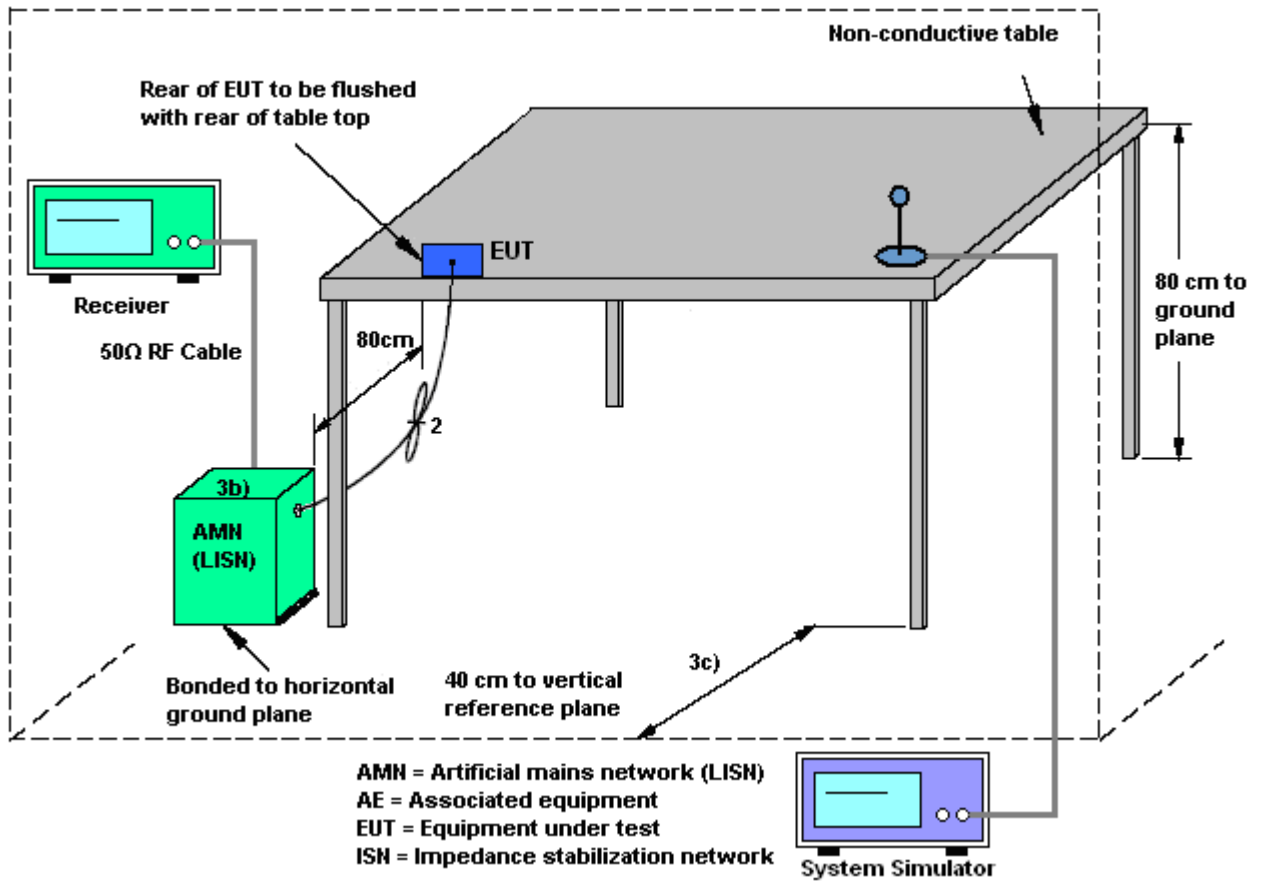

3.9.5 Test Result of AC Conducted Emission

Test Mode :	Mode 2	Temperature :	20~21°C
Test Engineer :	Kai-Chun Chu	Relative Humidity :	46~47%
Test Voltage :	120Vac / 60Hz	Phase :	Line
Function Type :	CDMA2000 BC15 Idle + Bluetooth Link + WLAN (2.4G) Link + MPEG4 + Earphone 1 + Battery 1 + USB Cable 1 (Charging from Adapter 1) for Sample 2		
Remark :	All emissions not reported here are more than 10 dB below the prescribed limit.		

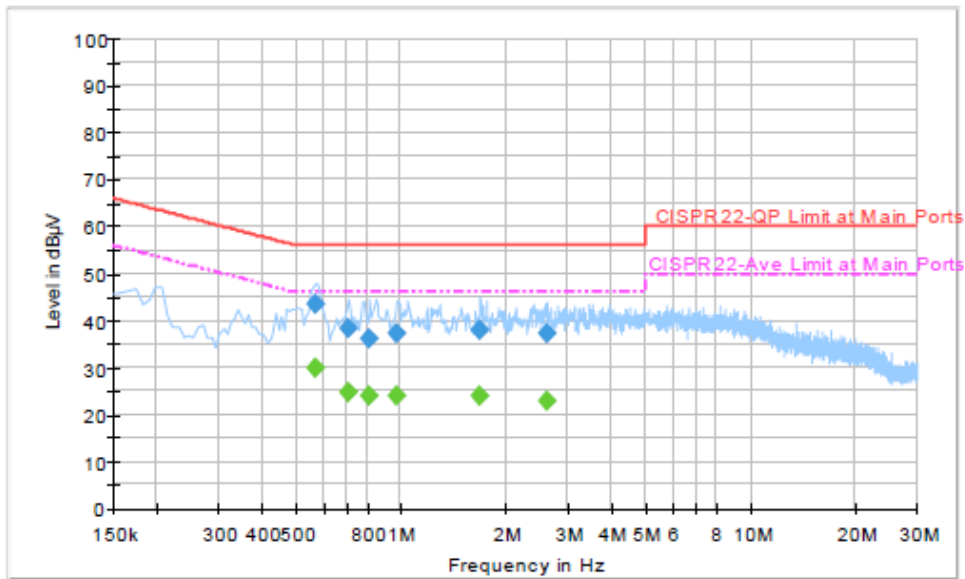

Final Result : Quasi-Peak

Frequency (MHz)	Quasi-Peak (dBµV)	Filter	Line	Corr. (dB)	Margin (dB)	Limit (dBµV)
0.566000	43.5	Off	L1	19.4	12.5	56.0
0.710000	38.4	Off	L1	19.5	17.6	56.0
0.814000	36.3	Off	L1	19.5	19.7	56.0
0.974000	37.2	Off	L1	19.4	18.8	56.0
1.686000	37.9	Off	L1	19.5	18.1	56.0
2.606000	37.1	Off	L1	19.6	18.9	56.0

Final Result : Average

Frequency (MHz)	Average (dBµV)	Filter	Line	Corr. (dB)	Margin (dB)	Limit (dBµV)
0.566000	29.7	Off	L1	19.4	16.3	46.0
0.710000	24.6	Off	L1	19.5	21.4	46.0
0.814000	23.8	Off	L1	19.5	22.2	46.0
0.974000	23.9	Off	L1	19.4	22.1	46.0
1.686000	23.9	Off	L1	19.5	22.1	46.0
2.606000	22.8	Off	L1	19.6	23.2	46.0

Test Mode :	Mode 2	Temperature :	20~21°C
Test Engineer :	Kai-Chun Chu	Relative Humidity :	46~47%
Test Voltage :	120Vac / 60Hz	Phase :	Neutral
Function Type :	CDMA2000 BC15 Idle + Bluetooth Link + WLAN (2.4G) Link + MPEG4 + Earphone 1 + Battery 1 + USB Cable 1 (Charging from Adapter 1) for Sample 2		
Remark :	All emissions not reported here are more than 10 dB below the prescribed limit.		

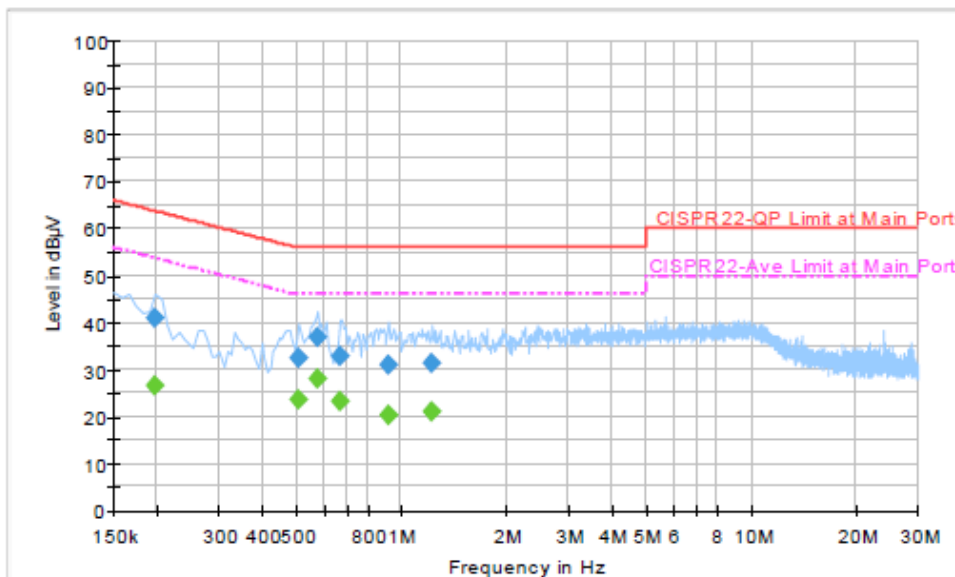

Final Result : Quasi-Peak

Frequency (MHz)	Quasi-Peak (dBµV)	Filter	Line	Corr. (dB)	Margin (dB)	Limit (dBµV)
0.198000	40.8	Off	N	19.3	22.9	63.7
0.510000	32.6	Off	N	19.4	23.4	56.0
0.574000	36.8	Off	N	19.4	19.2	56.0
0.670000	32.9	Off	N	19.5	23.1	56.0
0.918000	30.9	Off	N	19.4	25.1	56.0
1.222000	31.5	Off	N	19.5	24.5	56.0

Final Result : Average

Frequency (MHz)	Average (dBµV)	Filter	Line	Corr. (dB)	Margin (dB)	Limit (dBµV)
0.198000	26.7	Off	N	19.3	27.0	53.7
0.510000	23.6	Off	N	19.4	22.4	46.0
0.574000	27.9	Off	N	19.4	18.1	46.0
0.670000	23.1	Off	N	19.5	22.9	46.0
0.918000	20.2	Off	N	19.4	25.8	46.0
1.222000	20.9	Off	N	19.5	25.1	46.0



3.10 Antenna Requirements

3.10.1 Standard Applicable

If directional gain of transmitting antennas is greater than 6dBi, the power shall be reduced by the same level in dB comparing to gain minus 6dBi. The use of a permanently attached antenna or of an antenna that uses a unique coupling to the intentional radiator shall be considered sufficient to comply with the FCC rule.

3.10.2 Antenna Connected Construction

Non-standard connector used.

3.10.3 Antenna Gain

The antenna peak gain of EUT is less than 6 dBi. Therefore, it is not necessary to reduce maximum peak output power limit.



4 List of Measuring Equipment

Instrument	Manufacturer	Model No.	Serial No.	Characteristics	Calibration Date	Test Date	Due Date	Remark
Spectrum Analyzer	R&S	FSP40	100055	9kHz~40GHz	Jun. 06, 2012	Sep. 07, 2012 ~ Sep. 21, 2012	Jun. 05, 2013	Conducted (TH02-HY)
Bluetooth Base Station	R&S	CBT32	100519	N/A	Jun. 05, 2012	Sep. 07, 2012 ~ Sep. 21, 2012	Jun. 06, 2013	Conducted (TH02-HY)
EMI Test Receiver	R&S	ESCS 30	100356	9KHz ~ 2.75GHz	Oct. 27, 2011	Sep. 18, 2012	Oct. 26, 2012	Conduction (CO05-HY)
Two-LISN	R&S	ENV216	11-100081	9KHz ~ 30MHz	Dec. 09, 2011	Sep. 18, 2012	Dec. 08, 2012	Conduction (CO05-HY)
Two-LISN	R&S	ENV216	11-100080	9KHz ~ 30MHz	Dec. 06, 2011	Sep. 18, 2012	Dec. 05, 2012	Conduction (CO05-HY)
AC Power Source	APC	APC-1000W	N/A	N/A	N/A	Sep. 18, 2012	N/A	Conduction (CO05-HY)
System Simulator	R&S	CMU200	117995	N/A	Jul. 28, 2011	Sep. 18, 2012	Jul. 27, 2013	Conduction (CO05-HY)
Spectrum Analyzer	Agilent	E4408B	MY44211030	9KHz ~ 26.5GHz	Nov. 23, 2011	Sep. 16, 2012 ~ Sep. 27, 2012	Nov. 22, 2012	Radiation (03CH06-HY)
Spectrum Analyzer	R&S	FSP30	101352	9KHz-30GHz	Nov. 03, 2011	Sep. 16, 2012 ~ Sep. 27, 2012	Nov. 02, 2012	Radiation (03CH06-HY)
EMI Test Receiver	R&S	ESVS10	834468/003	20MHz ~ 1000MHz	May 04, 2012	Sep. 16, 2012 ~ Sep. 27, 2012	May. 03, 2013	Radiation (03CH06-HY)
Bilog Antenna	SCHAFFNER	CBL6112B	2885	30MHz ~ 2GHz	Oct. 22, 2011	Sep. 16, 2012 ~ Sep. 27, 2012	Oct. 21, 2012	Radiation (03CH06-HY)
Double Ridge Horn Antenna	EMCO	3117	00066583	1GHz ~ 18GHz	Aug. 01, 2012	Sep. 16, 2012 ~ Sep. 27, 2012	Jul. 31, 2013	Radiation (03CH06-HY)
SHF-EHF Horn Antenna	SCHWARZBECK	BBHA 9170	BBHA9170251	15GHz ~ 40GHz	Oct. 20, 2011	Sep. 16, 2012 ~ Sep. 27, 2012	Oct. 19, 2012	Radiation (03CH06-HY)
Preamplifier	Agilent	8449B	3008A01917	1GHz ~ 26.5GHz	Apr. 13, 2012	Sep. 16, 2012 ~ Sep. 27, 2012	Apr. 12, 2013	Radiation (03CH06-HY)
Amplifier	Agilent	310N	186713	9KHz ~ 1GHz	Apr. 11, 2012	Sep. 16, 2012 ~ Sep. 27, 2012	Apr. 10, 2013	Radiation (03CH06-HY)
Pre Amplifier	EMCI	EMC051845	SN980048	1GHz ~ 18GHz	Jul. 21, 2012	Sep. 16, 2012 ~ Sep. 27, 2012	Jul. 20, 2013	Radiation (03CH06-HY)
Pre Amplifier	MITEQ	AMF-7D-00101800-30-10P	159087	1GHz~18GHz	Feb. 27, 2012	Sep. 16, 2012 ~ Sep. 27, 2012	Feb. 26, 2013	Radiation (03CH06-HY)
Loop Antenna	R&S	HFH2-Z2	860004/001	9KHz ~ 30MHz	Jul. 03, 2012	Sep. 16, 2012 ~ Sep. 27, 2012	Jul. 02, 2014	Radiation (03CH06-HY)
Bluetooth Base Station	R&S	CBT32	100522	N/A	Feb. 09, 2012	Sep. 16, 2012 ~ Sep. 27, 2012	Feb. 08, 2014	Radiation (03CH06-HY)



5 Uncertainty of Evaluation

Uncertainty of Conducted Emission Measurement (150 KHz ~ 30 MHz)

Measuring Uncertainty for a Level of Confidence of 95% ($U = 2Uc(y)$)	2.26
---	------

Uncertainty of Radiated Emission Measurement (30 MHz ~ 1000 MHz)

Measuring Uncertainty for a Level of Confidence of 95% ($U = 2Uc(y)$)	2.54
---	------

Uncertainty of Radiated Emission Measurement (1 GHz ~ 40 GHz)

Measuring Uncertainty for a Level of Confidence of 95% ($U = 2Uc(y)$)	4.72
---	------