



A D T

# FCC TEST REPORT (PART 24)

**REPORT NO.:** RF120322C22A-1

**MODEL NO.:** PL01100

**FCC ID:** NM8PL01100

**RECEIVED:** Apr. 06, 2012

**TESTED:** Apr. 12, 2012

**ISSUED:** Apr. 18, 2012

**APPLICANT:** HTC Corporation

**ADDRESS:** 23, Xinghua Rd., Taoyuan 330, Taiwan, R.O.C.

**ISSUED BY:** Bureau Veritas Consumer Products Services  
(H.K.) Ltd., Taoyuan Branch

**LAB ADDRESS:** No. 47, 14th Ling, Chia Pau Vil., Lin Kou Dist., New  
Taipei City, Taiwan ( R.O.C. )

**TEST LOCATION:** No. 19, Hwa Ya 2nd Rd, Wen Hwa Tsuen, Kwei  
Shan Hsiang, Taoyuan Hsien 333, Taiwan, R.O.C.

This test report consists of 33 pages in total. It may be duplicated completely for legal use with the approval of the applicant. It should not be reproduced except in full, without the written approval of our laboratory. The client should not use it to claim product endorsement by TAF or any government agencies. The test results in the report only apply to the tested sample.





## TABLE OF CONTENTS

RELEASE CONTROL RECORD.....	3
1 CERTIFICATION .....	4
2 SUMMARY OF TEST RESULTS.....	5
2.1 MEASUREMENT UNCERTAINTY .....	5
2.2 TEST SITE AND INSTRUMENTS .....	6
3 GENERAL INFORMATION.....	7
3.1 GENERAL DESCRIPTION OF EUT.....	7
3.2 CONFIGURATION OF SYSTEM UNDER TEST.....	8
3.3 DESCRIPTION OF SUPPORT UNITS.....	9
3.4 TEST ITEM AND TEST CONFIGURATION .....	9
3.5 EUT OPERATING CONDITIONS.....	10
3.6 GENERAL DESCRIPTION OF APPLIED STANDARDS.....	10
4 TEST TYPES AND RESULTS .....	11
4.1 OUTPUT POWER MEASUREMENT .....	11
4.1.1 LIMITS OF OUTPUT POWER MEASUREMENT .....	11
4.1.2 TEST PROCEDURES .....	11
4.1.3 TEST SETUP.....	12
4.1.4 TEST RESULTS .....	13
4.2 FREQUENCY STABILITY MEASUREMENT .....	15
4.2.1 LIMITS OF FREQUENCY STABILITY MEASUREMENT .....	15
4.2.2 TEST PROCEDURE .....	15
4.2.3 TEST SETUP.....	15
4.2.4 TEST RESULTS .....	16
4.3 OCCUPIED BANDWIDTH MEASUREMENT.....	18
4.3.1 TEST PROCEDURES .....	18
4.3.2 TEST SETUP.....	18
4.3.3 TEST RESULTS .....	19
4.4 BAND EDGE MEASUREMENT .....	20
4.4.1 LIMITS OF BAND EDGE MEASUREMENT.....	20
4.4.2 TEST SETUP.....	20
4.4.3 TEST PROCEDURES .....	20
4.4.4 TEST RESULTS .....	21
4.5 CONDUCTED SPURIOUS EMISSIONS.....	22
4.5.1 LIMITS OF CONDUCTED SPURIOUS EMISSIONS MEASUREMENT .....	22
4.5.2 TEST PROCEDURE .....	22
4.5.3 TEST SETUP.....	22
4.5.4 TEST RESULTS .....	23
4.6 RADIATED EMISSION MEASUREMENT .....	25
4.6.1 LIMITS OF RADIATED EMISSION MEASUREMENT .....	25
4.6.2 TEST PROCEDURES .....	25
4.6.3 DEVIATION FROM TEST STANDARD .....	25
4.6.4 TEST SETUP.....	26
4.6.5 TEST RESULTS .....	27
5 PHOTOGRAPHS OF THE TEST CONFIGURATION .....	31
6 INFORMATION ON THE TESTING LABORATORIES.....	32
7 APPENDIX A – MODIFICATIONS RECORDERS FOR ENGINEERING CHANGES TO THE EUT BY THE LAB .....	33



A D T

## RELEASE CONTROL RECORD

ISSUE NO.	REASON FOR CHANGE	DATE ISSUED
RF120322C22A-1	Original release	Apr. 18, 2012



A D T

## 1 CERTIFICATION

**PRODUCT:** Smart Phone

**MODEL:** PL01100

**BRAND:** HTC

**APPLICANT:** HTC Corporation

**TESTED:** Apr. 12, 2012

**TEST SAMPLE:** Production Unit

**STANDARDS:** FCC Part 24, Subpart E

The above equipment (model: PL01100) has been tested by **Bureau Veritas Consumer Products Services (H.K.) Ltd., Taoyuan Branch**, and found compliance with the requirement of the above standards. The test record, data evaluation & Equipment Under Test (EUT) configurations represented herein are true and accurate accounts of the measurements of the sample's EMC characteristics under the conditions specified in this report.

PREPARED BY :  , DATE : Apr. 18, 2012  
Pettie Chen / Specialist

APPROVED BY :  , DATE : Apr. 18, 2012  
Gary Chang / Technical Manager



## 2 SUMMARY OF TEST RESULTS

The EUT has been tested according to the following specifications:

APPLIED STANDARD: FCC Part 24 & Part 2			
STANDARD SECTION	TEST TYPE	RESULT	REMARK
2.1046 24.232	Equivalent isotropically radiated power	PASS	Meet the requirement of limit.
2.1055 24.235	Frequency Stability	PASS	Meet the requirement of limit.
2.1049 24.238(b)	Occupied Bandwidth	PASS	Meet the requirement of limit.
24.238(b)	Band Edge Measurements	PASS	Meet the requirement of limit.
2.1051 24.238	Conducted Spurious Emissions	PASS	Meet the requirement of limit.
2.1053 24.238	Radiated Spurious Emissions	PASS	Meet the requirement of limit. Minimum passing margin is -21.34dB at 34.32MHz.

### 2.1 MEASUREMENT UNCERTAINTY

Where relevant, the following measurement uncertainty levels have been estimated for tests performed on the EUT as specified in CISPR 16-4-2:

MEASUREMENT	FREQUENCY	UNCERTAINTY
Conducted emissions	150kHz~30MHz	2.44 dB
Radiated emissions	30MHz ~ 200MHz	3.34 dB
	200MHz ~1000MHz	3.35 dB
	1GHz ~ 18GHz	2.26 dB
	18GHz ~ 40GHz	1.94 dB

This uncertainty represents an expanded uncertainty expressed at approximately the 95% confidence level using a coverage factor of k=2.



A D T

## 2.2 TEST SITE AND INSTRUMENTS

DESCRIPTION & MANUFACTURER	MODEL NO.	SERIAL NO.	DATE OF CALIBRATION	DUE DATE OF CALIBRATION
Test Receiver Agilent	N9038A	MY51210203	Dec. 22, 2011	Dec. 21, 2012
Spectrum Analyzer ROHDE & SCHWARZ	FSU43	101261	Dec. 21, 2011	Dec. 20, 2012
BILOG Antenna SCHWARZBECK	VULB9168	9168-472	Dec. 20, 2011	Dec. 19, 2012
HORN Antenna SCHWARZBECK	BBHA 9120 D	9120D-969	Dec. 20, 2011	Dec. 19, 2012
HORN Antenna SCHWARZBECK	BBHA 9170	9170-480	Dec. 20, 2011	Dec. 19, 2012
Preamplifier EMCI	EMC 012645	980115	Dec. 30, 2011	Dec. 29, 2012
Preamplifier EMCI	EMC 330H	980112	Dec. 30, 2011	Dec. 29, 2012
RF signal cable HUBER+SUHNNER	SUCOFLEX 104	309219/4	Oct. 21, 2011	Oct. 20, 2012
RF signal cable HUBER+SUHNNER	SUCOFLEX 104	250130/4	Jan. 02, 2012	Jan. 01, 2013
RF signal cable Worken	RG-213	NA	Jan. 02, 2012	Jan. 01, 2013
Software	E3 6.120103	NA	NA	NA
Antenna Tower MF	MFA-440H	NA	NA	NA
Turn Table MF	MFT-201SS	NA	NA	NA
Antenna Tower & Turn Table Controller MF	MF-7802	NA	NA	NA

- NOTE:**
1. The calibration interval of the above test instruments is 12 months and the calibrations are traceable to NML/ROC and NIST/USA.
  2. The test was performed in HwaYa Chamber 9.
  3. The horn antenna and HP preamplifier (model: 8449B) are used only for the measurement of emission frequency above 1GHz if tested.
  4. The FCC Site Registration No. is 460141.
  5. The IC Site Registration No. is IC 7450F-4.



### 3 GENERAL INFORMATION

#### 3.1 GENERAL DESCRIPTION OF EUT

<b>EUT</b>	Smart Phone
<b>MODEL NO.</b>	PL01100
<b>POWER SUPPLY</b>	5.0Vdc (adapter or host equipment) 3.7Vdc (battery)
<b>MODULATION TYPE</b>	<b>GSM, GPRS:</b> GMSK <b>EDGE:</b> 8PSK
<b>FREQUENCY RANGE</b>	1850.2MHz ~ 1909.8MHz
<b>MAX. EIRP POWER</b>	<b>GSM:</b> 0.70Watts <b>EDGE:</b> 0.30Watts
<b>ANTENNA TYPE</b>	Fixed Internal antenna with 0 dBi gain
<b>I/O PORTS</b>	Refer to users' manual
<b>DATA CABLE</b>	N/A
<b>ACCESSORY DEVICES</b>	N/A

**NOTE:**

1. The EUT's accessories list refers to Ext Pho.pdf.
2. The above EUT information was declared by manufacturer and for more detailed features description, please refer to the manufacturer's specifications or User's Manual.

### 3.2 CONFIGURATION OF SYSTEM UNDER TEST

#### FOR RADIATION EMISSION TEST

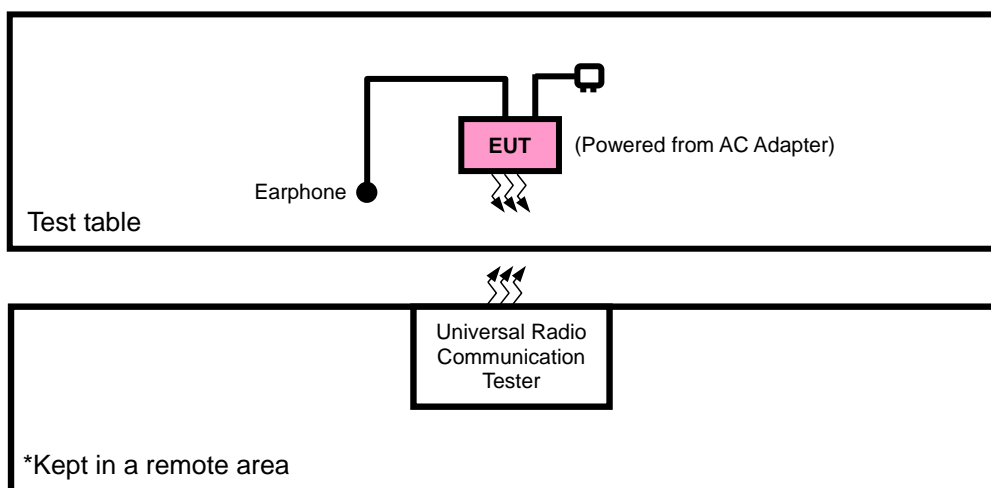

#### FOR E.I.R.P. TEST

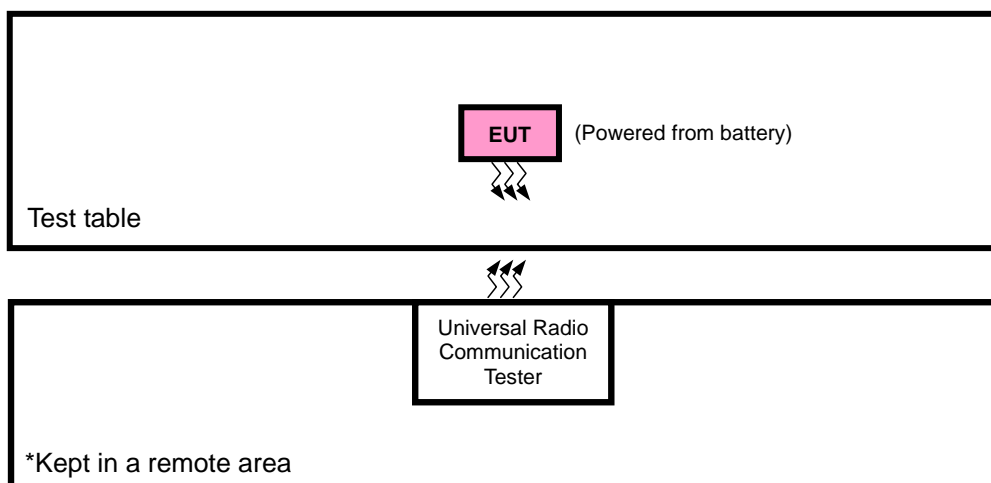





### 3.3 DESCRIPTION OF SUPPORT UNITS

The EUT has been tested as an independent unit together with other necessary accessories or support units. The following support units or accessories were used to form a representative test configuration during the tests.

NO.	PRODUCT	BRAND	MODEL NO.	SERIAL NO.	FCC ID
1	UNIVERSAL RADIO COMMUNICATION TESTER	R&S	CMU200	104484	NA

NO.	SIGNAL CABLE DESCRIPTION OF THE ABOVE SUPPORT UNITS
1	NA

**NOTE:**

1. All power cords of the above support units are non shielded (1.8m).
2. Item 1 acted as a communication partners to transfer data.

### 3.4 TEST ITEM AND TEST CONFIGURATION

Pre-Scan has been conducted to determine the worst-case mode from all possible combinations between available modulations, data rates, XYZ axis and antenna ports. The worst case was found when positioned on Y-plane for EIRP and X-axis for radiated emission. Following channel(s) was (were) selected for the final test as listed below:

EUT CONFIGURE MODE	TEST ITEM	AVAILABLE CHANNEL	TESTED CHANNEL	MODE
	EIRP	512 to 810	512, 661, 810	GSM, EDGE
	FREQUENCY STABILITY	512 to 810	661	GSM, EDGE
	OCCUPIED BANDWIDTH	512 to 810	512, 661, 810	GSM, EDGE
	BAND EDGE	512 to 810	512, 810	GSM, EDGE
	CONDCUDED EMISSION	512 to 810	661	GSM, EDGE
	RADIATED EMISSION	512 to 810	661	GSM, EDGE

**TEST CONDITION:**

TEST ITEM	ENVIRONMENTAL CONDITIONS	INPUT POWER	TESTED BY
ERP	25deg. C, 65%RH	3.7Vdc	Phoenix Chen
FREQUENCY STABILITY	25deg. C, 65%RH	3.7Vdc	Phoenix Chen
OCCUPIED BANDWIDTH	25deg. C, 65%RH	3.7Vdc	Phoenix Chen
BAND EDGE	25deg. C, 65%RH	3.7Vdc	Phoenix Chen
CONDCUDED EMISSION	25deg. C, 65%RH	3.7Vdc	Phoenix Chen
RADIATED EMISSION	25deg. C, 65%RH	120Vac, 60Hz	Kay Wu

### **3.5 EUT OPERATING CONDITIONS**

The EUT makes a call to the communication simulator. The communication simulator station system controlled a EUT to export maximum output power under transmission mode and specific channel frequency

### **3.6 GENERAL DESCRIPTION OF APPLIED STANDARDS**

The EUT is a RF product. According to the specifications of the manufacturer, it must comply with the requirements of the following standards:

**FCC 47 CFR Part 2**

**FCC 47 CFR Part 24**

**ANSI/TIA/EIA-603-C 2004**

**NOTE:** All test items have been performed and recorded as per the above standards.

## 4 TEST TYPES AND RESULTS

### 4.1 OUTPUT POWER MEASUREMENT

#### 4.1.1 LIMITS OF OUTPUT POWER MEASUREMENT

Mobile and portable stations are limited to 2 watts EIRP

#### 4.1.2 TEST PROCEDURES

##### **EIRP MEASUREMENT:**

- a. All measurements were done at low, middle and high operational frequency range. RWB and VBW is 1MHz for GSM & EDGE mode.
- b. Substitution method is used for E.I.R.P measurement. In the semi-anechoic chamber, EUT placed on the 0.8m height of Turn Table, rotated the table around 360 degrees to search the maximum radiation power and receiver antenna shall be rotated vertical and horizontal polarization and moved height from 1m to 4m to find the maximum polar radiated power. The “Read Value” is the spectrum reading the maximum power value.
- c. The substitution horn antenna is substituted for EUT at the same position and signals generator export the CW signal to the substitution antenna via a tx cable. Rotated the Turn Table and moved receiving antenna to find the maximum radiation power. Adjust output power level of S.G to get a Value of spectrum reading equal to “Read Value” of step b. Record the power level of S.G
- d.  $EIRP = \text{Output power level of S.G} - \text{TX cable loss} + \text{Antenna gain of substitution horn.}$

##### **CONDUCTED POWER MEASUREMENT:**

The EUT was set up for the maximum power with GSM & EDGE link data modulation and link up with simulator. Set the EUT to transmit under low, middle and high channel and record the power level shown on simulator.

### 4.1.3 TEST SETUP

#### EIRP MEASUREMENT:

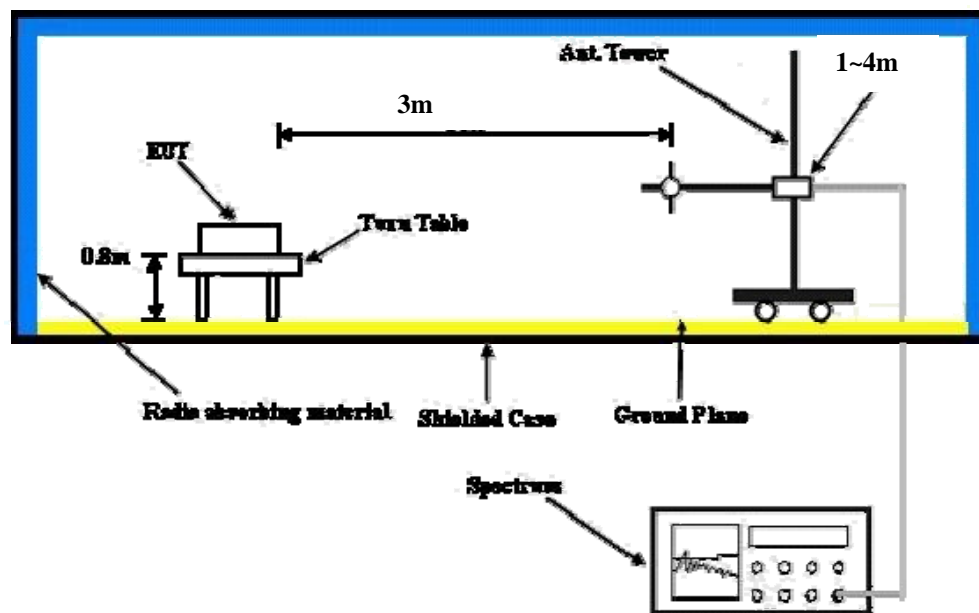

For the actual test configuration, please refer to the attached file (Test Setup Photo).

#### CONDUCTED POWER MEASUREMENT:

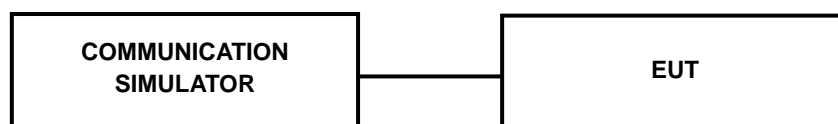

For the actual test configuration, please refer to the attached file (Test Setup Photo).



A D T

#### 4.1.4 TEST RESULTS

##### CONDUCTED OUTPUT POWER (dBm)

Band	GSM1900		
	512	661	810
Channel	1850.2	1880	1909.8
Frequency	1850.2	1880	1909.8
GSM	29.79	29.68	29.53
GPRS 8	29.78	29.67	29.52
GPRS 10	29.23	29.15	29.02
GPRS 11	27.33	27.24	27.10
GPRS 12	26.21	26.14	26.02
EDGE 8 (MCS1)	26.26	26.20	26.13
EDGE 10 (MCS1)	26.24	26.18	26.11
EDGE 11 (MCS1)	26.19	26.14	26.07
EDGE 12 (MCS1)	26.17	26.11	26.03
EDGE 8 (MCS9)	26.24	26.17	26.09
EDGE 10 (MCS9)	25.23	25.16	25.09
EDGE 11 (MCS9)	25.20	25.14	25.08
EDGE 12 (MCS9)	23.68	23.63	23.56



A D T

## EIRP POWER (dBm)

### GSM 1900

Plane	Channel	Frequency (MHz)	LVL (dBm)	Correction Factor(dB)	EIRP(dBm)	EIRP(W)	Polarization (H/V)
Y	512	1850.2	-17.19	38.19	21.00	0.13	H
	661	1880.0	-17.05	38.70	21.65	0.15	H
	810	1909.8	-17.11	39.35	22.24	0.17	H
	512	1850.2	-10.68	38.48	27.80	0.60	V
	661	1880.0	-10.42	38.59	28.17	0.66	V
	810	1909.8	-10.40	38.87	28.47	0.70	V

### EDGE 1900

Plane	Channel	Frequency (MHz)	LVL (dBm)	Correction Factor(dB)	EIRP(dBm)	EIRP(W)	Polarization (H/V)
Y	512	1850.2	-20.00	38.19	18.19	0.07	H
	661	1880.0	-20.71	38.70	17.99	0.06	H
	810	1909.8	-20.59	39.35	18.76	0.08	H
	512	1850.2	-14.00	38.48	24.48	0.28	V
	661	1880.0	-13.97	38.59	24.62	0.29	V
	810	1909.8	-14.11	38.87	24.76	0.30	V

## 4.2 FREQUENCY STABILITY MEASUREMENT

### 4.2.1 LIMITS OF FREQUENCY STABILITY MEASUREMENT

The frequency stability shall be sufficient to ensure that the fundamental emission stays within the authorized frequency block.

### 4.2.2 TEST PROCEDURE

- a. Device is placed at the oven room. The oven room could control the temperatures and humidity. Power warm up is at least 15 min and power applied should perform before recording frequency error.
- b. EUT is connected the external power supply to control the DC input power. The test voltage range is from minimum to maximum working voltage. Each step shall be record the frequency error rate.
- c. The temperature range step is 10 degrees in this test items. All temperature levels shall be hold the  $\pm 0.5^{\circ}\text{C}$  during the measurement testing. The each temperature step shall be at least 0.5 hours, consider the EUT could be test under the stability condition.

**NOTE:** The frequency error was recorded frequency error from the communication simulator.

### 4.2.3 TEST SETUP

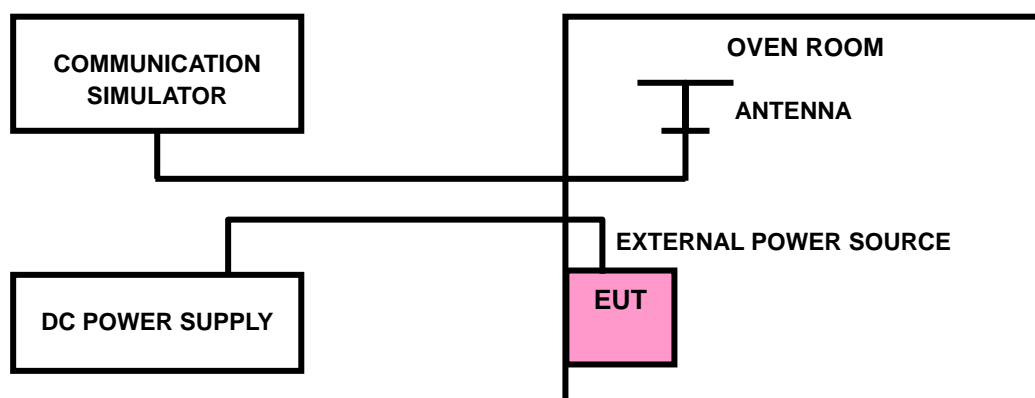



A D T

## 4.2.4 TEST RESULTS

### GSM 1900

#### FREQUENCY ERROR VS. VOLTAGE

AFC FREQUENCY ERROR vs. VOLTAGE			
VOLTAGE (Volts)	FREQUENCY ERROR (Hz)	FREQUENCY ERROR (ppm)	LIMIT (ppm)
3.7	-28.71	-0.02	2.5
3.6	-24.06	-0.01	2.5
4.2	-23.91	-0.01	2.5

**NOTE:** The applicant defined the normal working voltage of the battery is from 3.6Vdc to 4.2Vdc.

#### FREQUENCY ERROR vs. TEMPERATURE.

AFC FREQUENCY ERROR VS. TEMP			
TEMP. (°C)	FREQUENCY ERROR (Hz)	FREQUENCY ERROR (ppm)	LIMIT (ppm)
-10	-21.53	-0.01	2.5
0	-18.22	-0.01	2.5
10	-15.15	-0.01	2.5
20	-26.20	-0.01	2.5
30	-21.62	-0.01	2.5
40	-25.38	-0.01	2.5
50	-21.11	-0.01	2.5
55	-26.93	-0.01	2.5



**EDGE 1900****FREQUENCY ERROR VS. VOLTAGE**

<b>AFC FREQUENCY ERROR vs. VOLTAGE</b>			
<b>VOLTAGE (Volts)</b>	<b>FREQUENCY ERROR (Hz)</b>	<b>FREQUENCY ERROR (ppm)</b>	<b>LIMIT (ppm)</b>
3.7	16.38	0.01	2.5
3.6	16.07	0.01	2.5
4.2	16.40	0.01	2.5

**NOTE:** The applicant defined the normal working voltage of the battery is from 3.6Vdc to 4.2Vdc.

**FREQUENCY ERROR vs. TEMPERATURE.**

<b>AFC FREQUENCY ERROR VS. TEMP</b>			
<b>TEMP. (°C)</b>	<b>FREQUENCY ERROR (Hz)</b>	<b>FREQUENCY ERROR (ppm)</b>	<b>LIMIT (ppm)</b>
-10	16.11	0.01	2.5
0	-15.95	-0.01	2.5
10	14.43	0.01	2.5
20	16.01	0.01	2.5
30	18.99	0.01	2.5
40	14.58	0.01	2.5
50	17.00	0.01	2.5
55	18.12	0.01	2.5

### 4.3 OCCUPIED BANDWIDTH MEASUREMENT

#### 4.3.1 TEST PROCEDURES

The EUT makes a call to the communication simulator. All measurements were done at low, middle and high operational frequency range. The communication simulator station system controlled a EUT to export maximum output power under transmission mode and specific channel frequency. Use OBW measurement function of Spectrum analyzer to measure 99 % occupied bandwidth.

#### 4.3.2 TEST SETUP

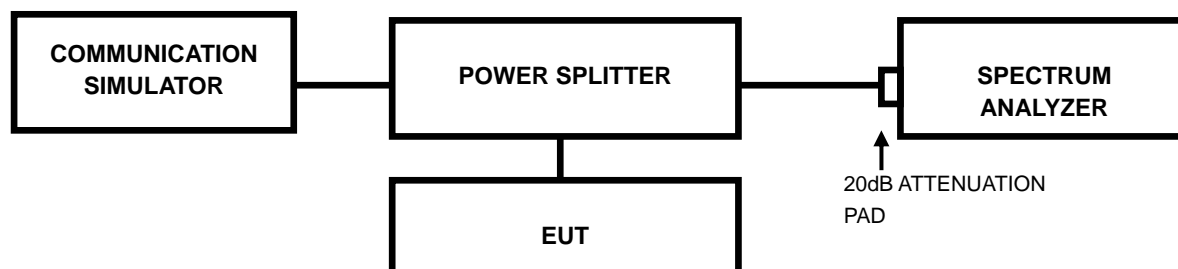



A D T

### 4.3.3 TEST RESULTS

CHANNEL	FREQUENCY (MHz)	99% OCCUPIED BANDWIDTH (kHz)	
		GSM	EDGE
512	1850.2	244.94	246.21
661	1880.0	244.94	240.99
810	1909.8	242.87	243.97

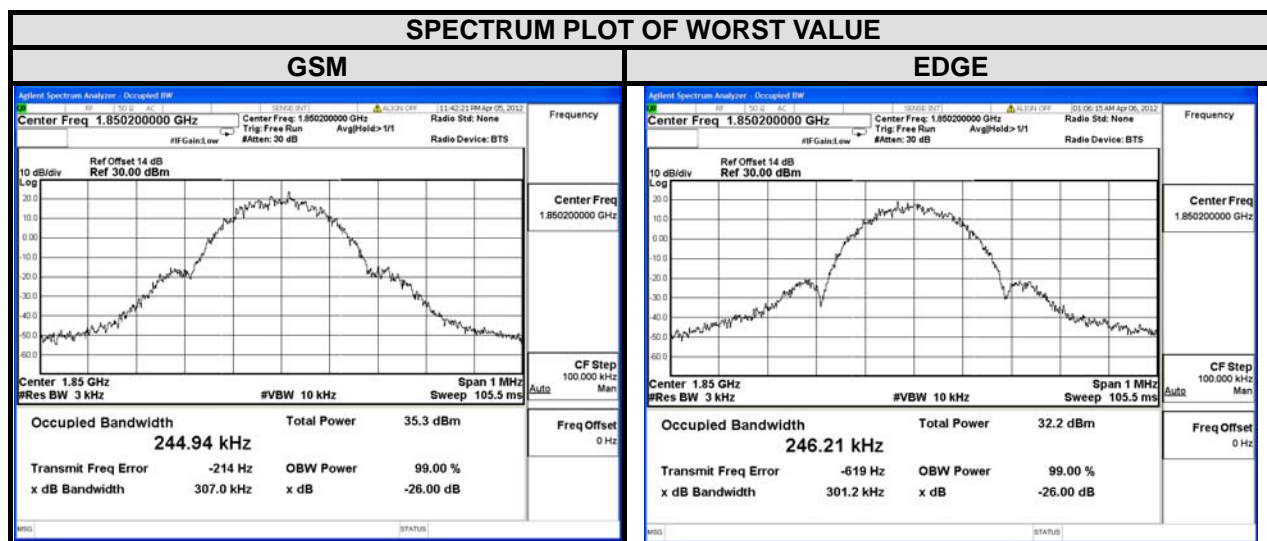

## 4.4 BAND EDGE MEASUREMENT

### 4.4.1 LIMITS OF BAND EDGE MEASUREMENT

Power of any emission outside of the authorized operating frequency ranges must be attenuated below the transmitting power (P) by a factor of at least  $43 + 10 \log(P)$  dB. In the 1 MHz bands immediately outside and adjacent to the frequency block a resolution bandwidth of at least one percent of the emission bandwidth of the fundamental emission of the transmitter may be employed.

### 4.4.2 TEST SETUP

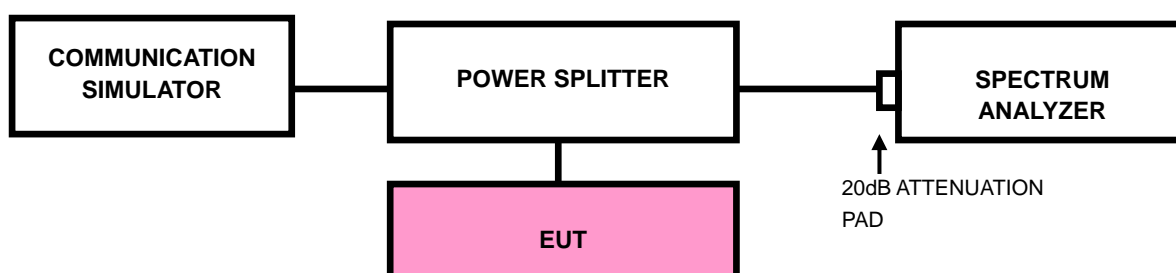

### 4.4.3 TEST PROCEDURES

- All measurements were done at low and high operational frequency range.
- The center frequency of spectrum is the band edge frequency and span is 1.5 MHz. RB of the spectrum is 3kHz and VB of the spectrum is 10kHz (GSM / EDGE).
- Record the max trace plot into the test report.



A D T

### 4.4.4 TEST RESULTS

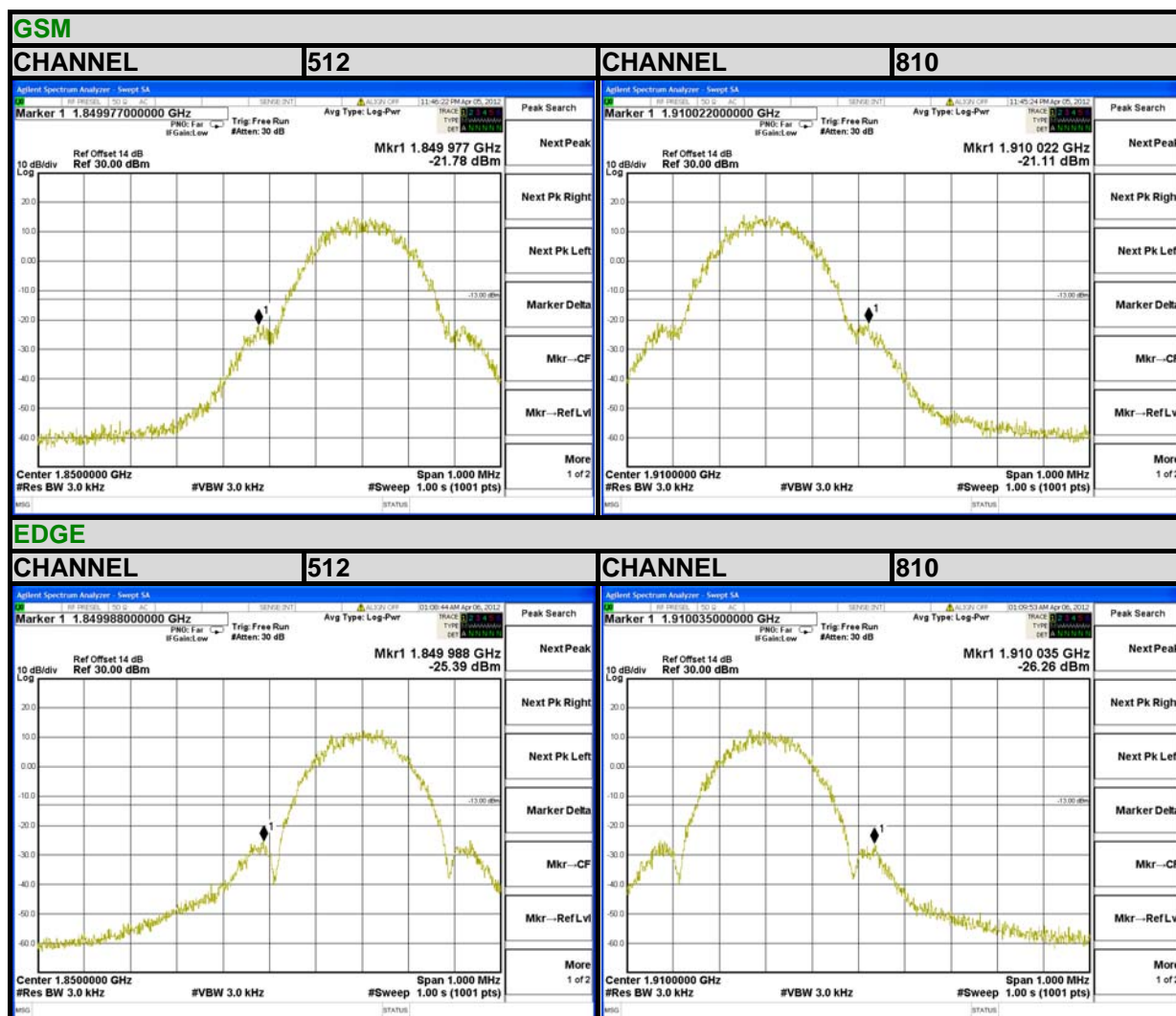

## 4.5 CONDUCTED SPURIOUS EMISSIONS

### 4.5.1 LIMITS OF CONDUCTED SPURIOUS EMISSIONS MEASUREMENT

The power of any emission outside of the authorized operating frequency ranges must be attenuated below the transmitting power (P) by a factor of at least  $43 + 10 \log(P)$  dB. The emission limit equal to  $-13\text{dBm}$ .

### 4.5.2 TEST PROCEDURE

- a. The EUT makes a phone call to the communication simulator. All measurements were done at low, middle and high operational frequency range.
- b. Measuring frequency range is from 30MHz to 19.1GHz. 10dB attenuation pad is connected with spectrum. RBW=1MHz and VBW=3MHz is used for conducted emission measurement.

### 4.5.3 TEST SETUP

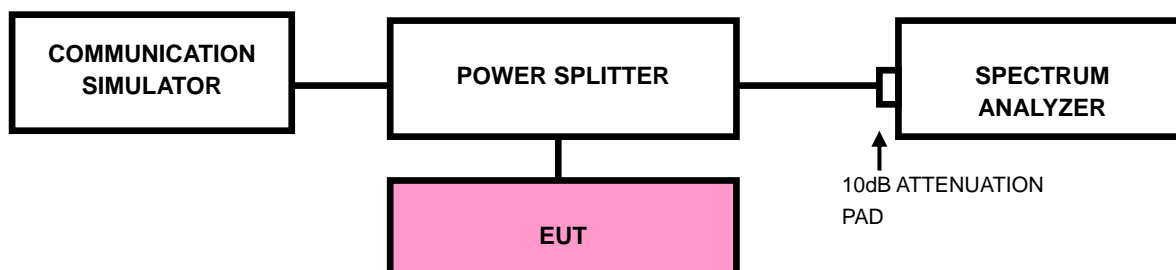



A D T

### 4.5.4 TEST RESULTS

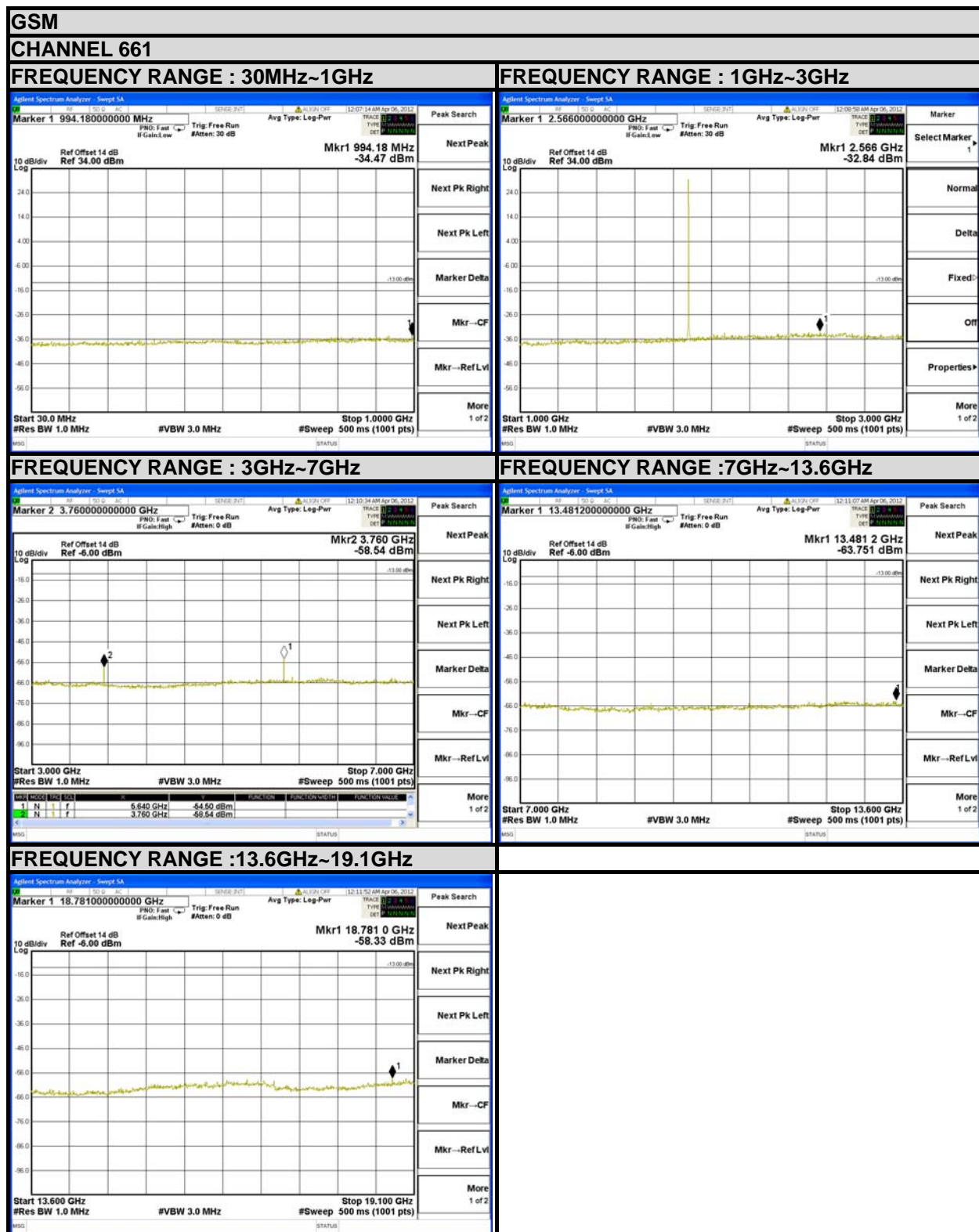



A D T

### EDGE

### CHANNEL 661

### FREQUENCY RANGE : 30MHz~1GHz

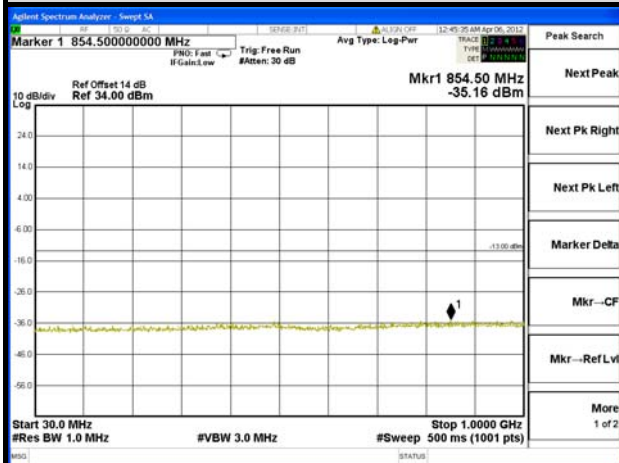

### FREQUENCY RANGE : 1GHz~3GHz

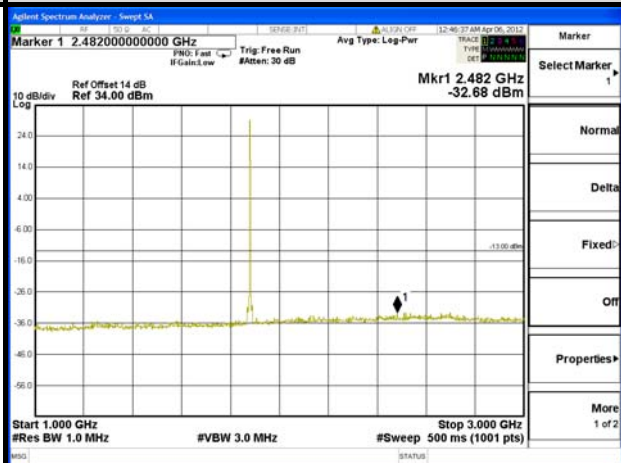

### FREQUENCY RANGE : 3GHz~7GHz

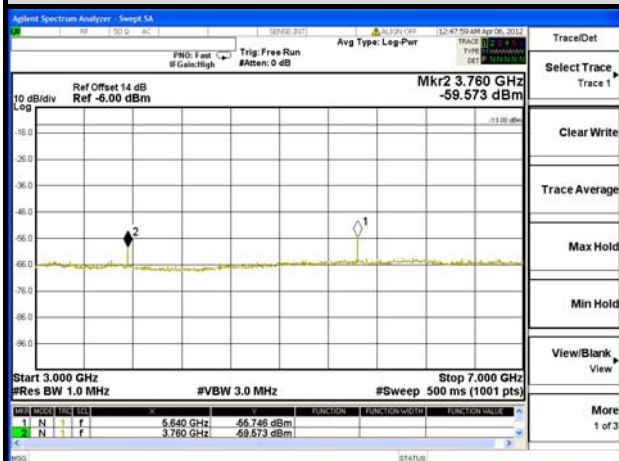

### FREQUENCY RANGE : 7GHz~13.6GHz

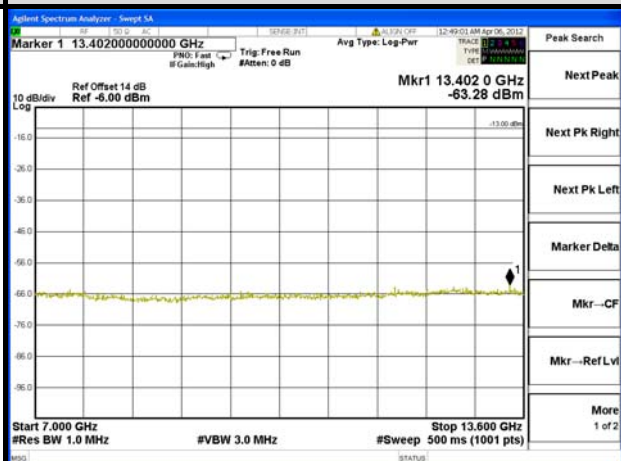

### FREQUENCY RANGE : 13.6GHz~19.1GHz

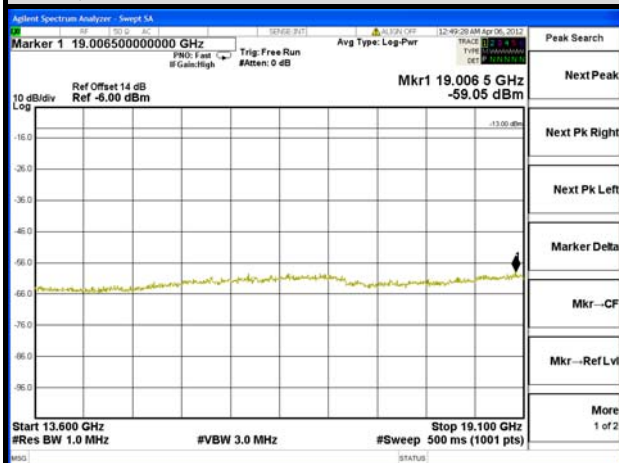



## 4.6 RADIATED EMISSION MEASUREMENT

### 4.6.1 LIMITS OF RADIATED EMISSION MEASUREMENT

The power of any emission outside of the authorized operating frequency ranges must be attenuated below the transmitting power (P) by a factor of at least  $43 + 10 \log(P)$  dB. The emission limit equal to  $-13\text{dBm}$ .

### 4.6.2 TEST PROCEDURES

- a. Substitution method is used for E.I.R.P measurement. In the semi-anechoic chamber, EUT placed on the 0.8m height of Turn Table, rotated the table around 360 degrees to search the maximum radiation power and receiver antenna shall be rotated vertical and horizontal polarization and moved height from 1m to 4m to find the maximum polar radiated power. The “Read Value” is the spectrum reading the maximum power value.
- b. The substitution horn antenna is substituted for EUT at the same position and signals generator export the CW signal to the substitution antenna via a TX cable. Rotated the Turn Table and moved receiving antenna to find the maximum radiation power. Adjust output power level of S.G to get a Value of spectrum reading equal to “Read Value” of step a. Record the power level of S.G
- c.  $\text{EIRP} = \text{Output power level of S.G} - \text{TX cable loss} + \text{Antenna gain of substitution horn}$ .
- d. E.R.P power can be calculated form E.I.R.P power by subtracting the gain of dipole,  
 $\text{E.R.P power} = \text{E.I.P.R power} - 2.15\text{dBi}$ .

**NOTE:** The resolution bandwidth and video bandwidth of test receiver/spectrum analyzer is 1MHz/3MHz.

### 4.6.3 DEVIATION FROM TEST STANDARD

No deviation

#### 4.6.4 TEST SETUP

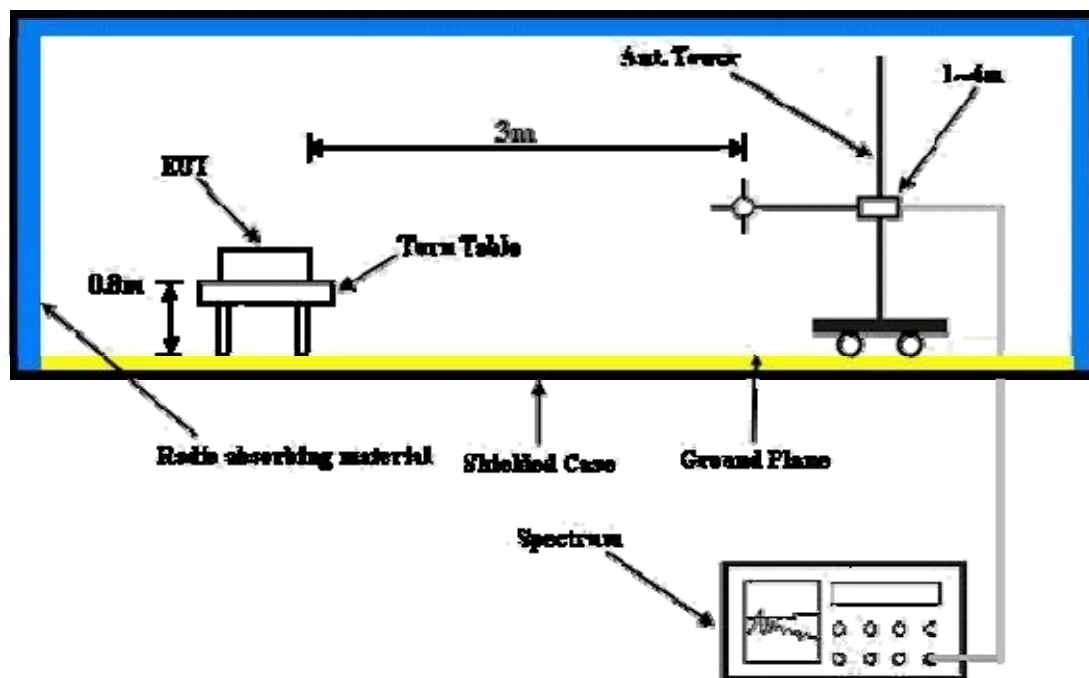

For the actual test configuration, please refer to the attached file (Test Setup Photo).



A D T

### 4.6.5 TEST RESULTS



Bureau Veritas Consumer Products Services Ltd., Taoyuan Branch

A D T

Data: 15

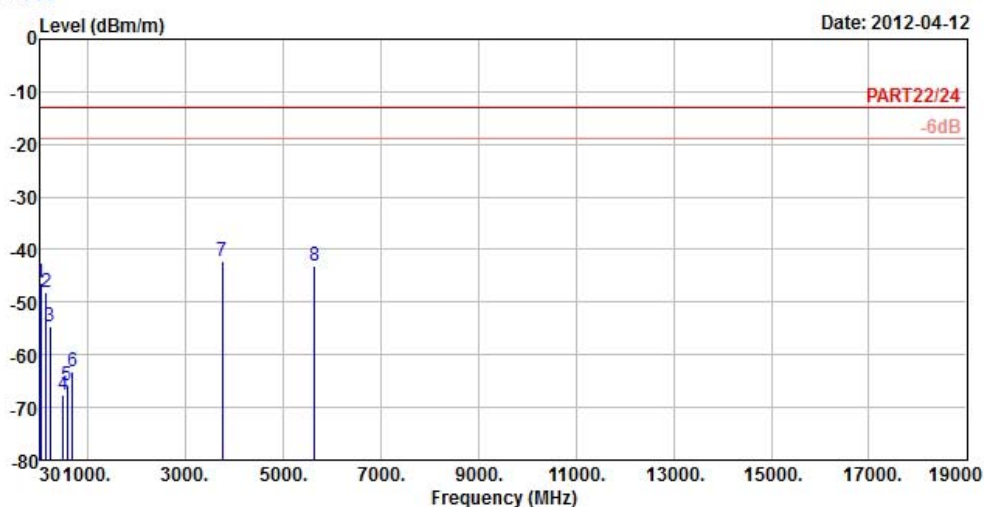

Site : 966 Chamber 5  
 Condition : PART22/24 3m EIRP\_RSE\_1G~19G\_3 HORIZONTAL  
 Brand/Model: PL01100  
 Remark : PCS1900 Link  
 Tested by : Kay Wu  
 Temperature : 25°C  
 Humidity : 65%  
 Plane : X

	Freq	Level	Read	Limit	Over		
	MHz	dBm/m	Level	Line	Limit	Factor	Remark
			dBm	dBm/m	dB	dB/m	
1	34.32	-46.44	-44.60	-13.00	-33.44	-1.84	Peak
2	143.94	-47.98	-42.06	-13.00	-34.98	-5.92	Peak
3	224.67	-54.55	-47.74	-13.00	-41.55	-6.81	Peak
4	500.20	-67.72	-64.63	-13.00	-54.72	-3.09	Peak
5	577.20	-65.69	-64.70	-13.00	-52.69	-0.99	Peak
6	685.70	-63.30	-64.49	-13.00	-50.30	1.19	Peak
7 pp	3760.00	-42.09	-35.36	-13.00	-29.09	-6.73	Peak
8	5640.00	-43.23	-43.44	-13.00	-30.23	0.21	Peak



A D T



### Bureau Veritas Consumer Products Services Ltd., Taoyuan Branch

A D T

Data: 16

Date: 2012-04-12

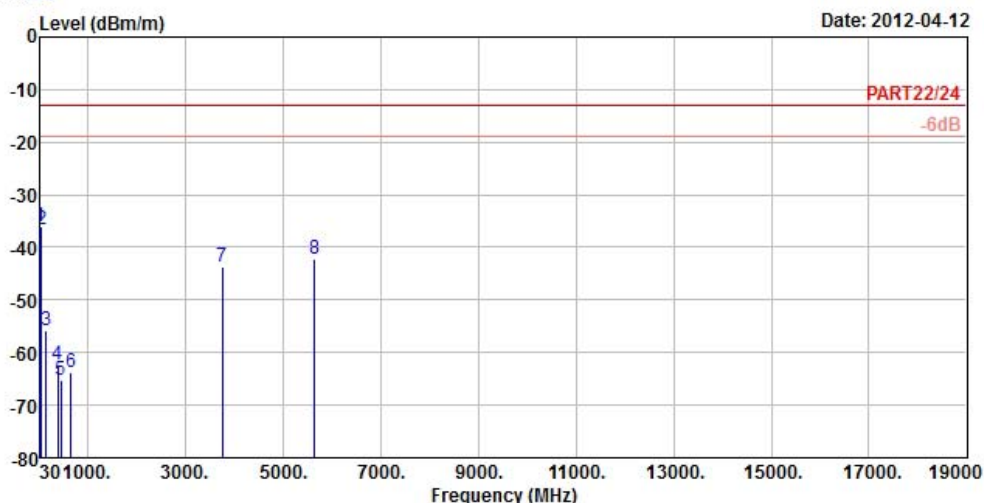

Site : 966 Chamber 5  
 Condition : PART22/24 3m EIRP\_RSE\_1G~19G\_3 VERTICAL  
 Brand/Model: PL01100  
 Remark : PCS1900 Link  
 Tested by : Kay Wu  
 Temperature : 25°C  
 Humidity : 65%  
 Plane : X

	Read	Limit	Over			
Level	Level	Line	Limit	Factor	Remark	
Freq	dBm/m	dBm	dBm/m	dB	dB/m	
MHz	dBm/m	dBm	dBm/m	dB	dB/m	
1 pp	34.05 -36.04	-34.20	-13.00	-23.04	-1.84	Peak
2	44.31 -36.59	-35.40	-13.00	-23.59	-1.19	Peak
3	139.89 -55.83	-50.16	-13.00	-42.83	-5.67	Peak
4	377.00 -62.20	-56.39	-13.00	-49.20	-5.81	Peak
5	454.70 -65.20	-60.96	-13.00	-52.20	-4.24	Peak
6	661.20 -63.64	-64.39	-13.00	-50.64	0.75	Peak
7	3760.00 -43.59	-36.86	-13.00	-30.59	-6.73	Peak
8	5640.00 -42.29	-42.50	-13.00	-29.29	0.21	Peak



A D T



Bureau Veritas Consumer Products Services Ltd., Taoyuan Branch

A D T

Data: 15

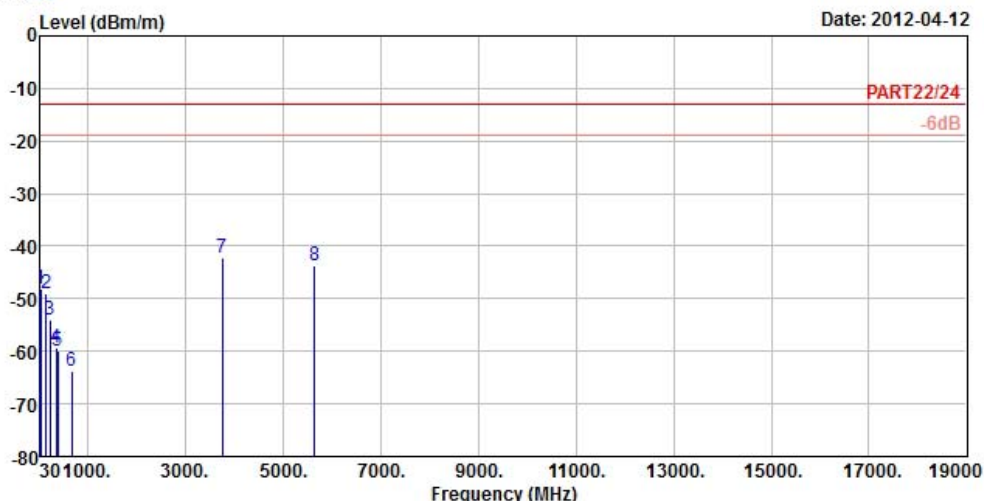

Site : 966 Chamber 5  
 Condition : PART22/24 3m EIRP\_RSE\_1G~19G\_3 HORIZONTAL  
 Brand/Model: PL01100  
 Remark : EDGE Link  
 Tested by : Kay Wu  
 Temperature : 25°C  
 Humidity : 65%  
 Plane : X

	Freq	Level	Read Level	Limit Line	Over Limit	Factor	Remark
	MHz	dBm/m	dBm	dBm/m	dB	dB/m	
1	34.86	-48.06	-45.49	-13.00	-35.06	-2.57	Peak
2	138.81	-49.15	-43.22	-13.00	-36.15	-5.93	Peak
3	225.75	-54.16	-47.39	-13.00	-41.16	-6.77	Peak
4	346.20	-59.40	-53.36	-13.00	-46.40	-6.04	Peak
5	392.40	-59.78	-54.09	-13.00	-46.78	-5.69	Peak
6	671.70	-63.80	-64.74	-13.00	-50.80	0.94	Peak
7 pp	3760.00	-42.27	-35.54	-13.00	-29.27	-6.73	Peak
8	5640.00	-43.60	-43.81	-13.00	-30.60	0.21	Peak



A D T



Bureau Veritas Consumer Products Services Ltd., Taoyuan Branch

A D T

Data: 16

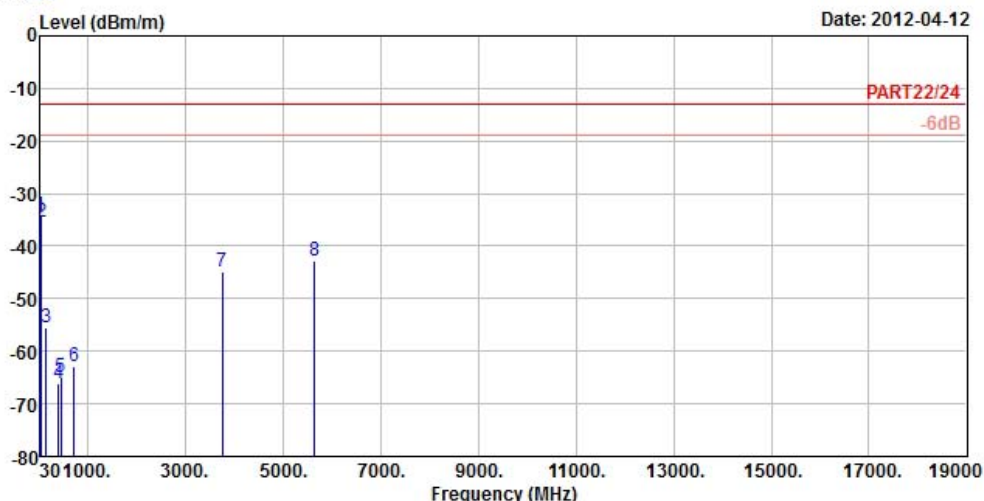

Site : 966 Chamber 5  
 Condition : PART22/24 3m EIRP\_RSE\_1G~19G\_3 VERTICAL  
 Brand/Model: PL01100  
 Remark : EDGE Link  
 Tested by : Kay Wu  
 Temperature : 25°C  
 Humidity : 65%  
 Plane : X

	Freq	Level	Read Level	Limit Line	Over Limit	Factor	Remark
	MHz	dBm/m	dBm	dBm/m	dB	dB/m	
1	pp	34.32	-34.34	-32.50	-13.00	-21.34	-1.84 Peak
2		44.04	-35.37	-34.11	-13.00	-22.37	-1.26 Peak
3		145.29	-55.58	-49.53	-13.00	-42.58	-6.05 Peak
4		407.10	-65.98	-60.54	-13.00	-52.98	-5.44 Peak
5		454.70	-64.95	-60.71	-13.00	-51.95	-4.24 Peak
6		713.00	-62.97	-64.51	-13.00	-49.97	1.54 Peak
7		3760.00	-44.97	-38.24	-13.00	-31.97	-6.73 Peak
8		5640.00	-42.77	-42.98	-13.00	-29.77	0.21 Peak

## 5 PHOTOGRAPHS OF THE TEST CONFIGURATION

Please refer to the attached file (Test Setup Photo).



## 6 INFORMATION ON THE TESTING LABORATORIES

We, Bureau Veritas Consumer Products Services (H.K.) Ltd., Taoyuan Branch, were founded in 1988 to provide our best service in EMC, Radio, Telecom and Safety consultation. Our laboratories are accredited and approved according to ISO/IEC 17025.

Copies of accreditation and authorization certificates of our laboratories obtained from approval agencies can be downloaded from our web site:

[www.adt.com.tw/index.5.phtml](http://www.adt.com.tw/index.5.phtml). If you have any comments, please feel free to contact us at the following:

**Linko EMC/RF Lab:**

Tel: 886-2-26052180

Fax: 886-2-26051924

**Hsin Chu EMC/RF Lab:**

Tel: 886-3-5935343

Fax: 886-3-5935342

**Hwa Ya EMC/RF/Safety/Telecom Lab:**

Tel: 886-3-3183232

Fax: 886-3-3270892

**Email:** [service.adt@tw.bureauveritas.com](mailto:service.adt@tw.bureauveritas.com)

**Web Site:** [www.adt.com.tw](http://www.adt.com.tw)

The address and road map of all our labs can be found in our web site also.





A D T

## **7 APPENDIX A – MODIFICATIONS RECORDERS FOR ENGINEERING CHANGES TO THE EUT BY THE LAB**

No any modifications are made to the EUT by the lab during the test.

---END---