



FCC TEST REPORT (PART 27)

REPORT NO.: RF111130C18-2

MODEL NO.: PJ83100

FCC ID: NM8PJ83100

RECEIVED: Nov. 30, 2011

TESTED: Jan. 10 ~ Jan. 17, 2012

ISSUED: Jan. 18, 2012

APPLICANT: HTC Corporation

ADDRESS: 23,Xinghua Rd., Taoyuan 330,Taiwan,R.O.C.

ISSUED BY: Bureau Veritas Consumer Products Services
(H.K.) Ltd., Taoyuan Branch

LAB ADDRESS: No. 47, 14th Ling, Chia Pau Vil., Lin Kou Dist.,
New Taipei City, Taiwan (R.O.C)

TEST LOCATION: No. 19, Hwa Ya 2nd Rd, Wen Hwa Tsuen, Kwei
Shan Hsiang, Taoyuan Hsien 333, Taiwan, R.O.C.

This test report consists of 148 pages in total. It may be duplicated completely for legal use with the approval of the applicant. It should not be reproduced except in full, without the written approval of our laboratory. The client should not use it to claim product, certification, approval or endorsement by TAF or any government agency. The test results in the report only apply to the tested sample.



TABLE OF CONTENTS

RELEASE CONTROL RECORD	4
1 CERTIFICATION	5
2 SUMMARY OF TEST RESULTS	6
2.1 MEASUREMENT UNCERTAINTY	7
3 GENERAL INFORMATION	8
3.1 GENERAL DESCRIPTION OF EUT	8
3.2 DESCRIPTION OF TEST MODES	9
3.2.1 CONFIGURATION OF SYSTEM UNDER TEST	10
3.2.2 TEST MODE APPLICABILITY AND TESTED CHANNEL DETAIL	11
3.3 GENERAL DESCRIPTION OF APPLIED STANDARDS	14
3.4 DESCRIPTION OF SUPPORT UNITS	14
4 TEST TYPES AND RESULTS	15
4.1 OUTPUT POWER MEASUREMENT	15
4.1.1 LIMITS OF OUTPUT POWER MEASUREMENT	15
4.1.2 TEST INSTRUMENTS	16
4.1.3 TEST PROCEDURES	17
4.1.4 TEST SETUP	18
4.1.5 EUT OPERATING CONDITIONS	18
4.1.6 TEST RESULTS	19
4.2 FREQUENCY STABILITY MEASUREMENT	25
4.2.1 LIMITS OF FREQUENCY STABILITY MEASUREMENT	25
4.2.2 TEST INSTRUMENTS	25
4.2.3 TEST PROCEDURE	26
4.2.4 TEST SETUP	26
4.2.5 TEST RESULTS	27
4.3 OCCUPIED BANDWIDTH MEASUREMENT	31
4.3.1 LIMITS OF OCCUPIED BANDWIDTH MEASUREMENT	31
4.3.2 TEST INSTRUMENTS	31
4.3.3 TEST SETUP	31
4.3.4 TEST PROCEDURES	31
4.3.5 TEST RESULTS	32
4.4 PEAK TO AVERAGE RATIO	40
4.4.1 LIMITS OF PEAK TO AVERAGE RATIO MEASUREMENT	40
4.4.2 TEST INSTRUMENTS	40
4.4.3 TEST SETUP	40
4.4.4 TEST PROCEDURES	41
4.4.5 EUT OPERATING CONDITION	41
4.4.6 TEST RESULTS	42
4.5 BAND EDGE MEASUREMENT	50
4.5.1 LIMITS OF BAND EDGE MEASUREMENT	50



4.5.2	TEST INSTRUMENTS	51
4.5.3	TEST SETUP	51
4.5.4	TEST PROCEDURES	52
4.5.5	EUT OPERATING CONDITION	52
4.5.6	TEST RESULTS	53
4.6	CONDUCTED SPURIOUS EMISSIONS	61
4.6.1	LIMITS OF CONDUCTED SPURIOUS EMISSIONS MEASUREMENT	61
4.6.2	TEST INSTRUMENTS	61
4.6.3	TEST PROCEDURE	62
4.6.4	TEST SETUP	62
4.6.5	EUT OPERATING CONDITIONS	62
4.6.6	TEST RESULTS	63
4.7	RADIATED EMISSION MEASUREMENT	111
4.7.1	LIMITS OF RADIATED EMISSION MEASUREMENT	111
4.7.2	TEST INSTRUMENTS	112
4.7.3	TEST PROCEDURES	113
4.7.4	DEVIATION FROM TEST STANDARD	113
4.7.5	TEST SETUP	114
4.7.6	EUT OPERATING CONDITIONS	114
4.7.7	TEST RESULTS	115
5	INFORMATION ON THE TESTING LABORATORIES	147
6	APPENDIX A – MODIFICATIONS RECORDERS FOR ENGINEERING CHANGES TO THE EUT BY THE LAB	148



A D T

RELEASE CONTROL RECORD

ISSUE NO.	REASON FOR CHANGE	DATE ISSUED
Original release	N/A	Jan. 18, 2012



1 CERTIFICATION

PRODUCT: Smart Phone
MODEL NO.: PJ83100
BRAND: HTC
APPLICANT: HTC Corporation
TESTED: Jan. 10 ~ Jan. 17, 2012
TEST SAMPLE: Production Unit
TEST STANDARDS: **FCC Part 27, Subpart C, L**
FCC Part 2
ANSI C63.4-2003

The above equipment (model: PJ83100) has been tested by **Bureau Veritas Consumer Products Services (H.K.) Ltd., Taoyuan Branch**, and found compliance with the requirement of the above standards. The test record, data evaluation & Equipment Under Test (EUT) configurations represented herein are true and accurate accounts of the measurements of the sample's EMC characteristics under the conditions specified in this report.

PREPARED BY : Ivonne Wu , DATE : Jan. 18, 2012
Ivonne Wu / Senior Specialist

APPROVED BY : Gary Chang , DATE : Jan. 18, 2012
Gary Chang / Technical Manager

2 SUMMARY OF TEST RESULTS

The EUT has been tested according to the following specifications:

OPERATING BAND: 704–716 MHz			
STANDARD SECTION	TEST TYPE AND LIMIT	RESULT	REMARK
2.1046 27.50(C)(10)	Maximum Peak Output Power Limit: max. 3 watts e.r.p peak power	PASS	Meet the requirement of limit. Minimum passing margin is 15.16dBm at 709.0MHz.
2.1055 27.54	Frequency Stability	PASS	Meet the requirement of limit.
2.1049 27.53(g)	Occupied Bandwidth	PASS	Meet the requirement of limit.
27.50(d)(5)	Peak to average ratio	PASS	Meet the requirement of limit.
27.53(g)	Band Edge Measurements	PASS	Meet the requirement of limit.
2.1051 27.53(g)	Conducted Spurious Emissions	PASS	Meet the requirement of limit.
2.1053 27.53(g)	Radiated Spurious Emissions	PASS	Meet the requirement of limit. Minimum passing margin is -6.83dB at 1428.80MHz.

OPERATING BAND: 1710~1755 MHz			
STANDARD SECTION	TEST TYPE AND LIMIT	RESULT	REMARK
2.1046 27.50(d)(4)	Maximum Peak Output Power Limit: max. 1 watts e.i.r.p peak power	PASS	Meet the requirement of limit. Minimum passing margin is 25.62dBm at 1715.0MHz.
2.1055 27.54	Frequency Stability	PASS	Meet the requirement of limit.
2.1049 27.53(h)	Occupied Bandwidth	PASS	Meet the requirement of limit.
27.50(d)(5)	Peak to average ratio	PASS	Meet the requirement of limit.
27.53(h)	Band Edge Measurements	PASS	Meet the requirement of limit.
2.1051 27.53(h)	Conducted Spurious Emissions	PASS	Meet the requirement of limit.
2.1053 27.53(h)	Radiated Spurious Emissions	PASS	Meet the requirement of limit. Minimum passing margin is -22.68dB at 8651.70MHz.

2.1 MEASUREMENT UNCERTAINTY

Where relevant, the following measurement uncertainty levels have been estimated for tests performed on the EUT as specified in CISPR 16-4-2:

MEASUREMENT	FREQUENCY	UNCERTAINTY
Conducted emissions	9kHz~30MHz	2.44 dB
Radiated emissions	30MHz ~ 200MHz	2.93 dB
	200MHz ~1000MHz	2.95 dB
	1GHz ~ 18GHz	2.26 dB
	18GHz ~ 40GHz	1.94 dB

This uncertainty represents an expanded uncertainty expressed at approximately the 95% confidence level using a coverage factor of k=2.

3 GENERAL INFORMATION

3.1 GENERAL DESCRIPTION OF EUT

PRODUCT	Smart Phone	
MODEL NO.	PJ83100	
FCC ID	NM8PJ83100	
POWER SUPPLY	5.0Vdc (adapter or host equipment) 3.7Vdc (battery)	
OPERATION TEMPERATURE RANGE	-10°C ~ 55°C	
MODULATION TECHNOLOGY	LTE Band 17	QPSK, 16QAM
	LTE Band 4	QPSK, 16QAM
FREQUENCY RANGE	LTE Band 17 Channel Bandwidth: 5MHz	706.5MHz ~ 713.5MHz
	LTE Band 17 Channel Bandwidth: 10MHz	709MHz ~ 711MHz
	LTE Band 4 Channel Bandwidth: 5MHz	1712.5MHz ~1752.5MHz
	LTE Band 4 Channel Bandwidth: 10MHz	1715.0MHz ~1750.0MHz
MAX. ERP POWER (W)	LTE Band 17	5MHz : 0.05W 10MHz : 0.03W
MAX. EIRP POWER (W)	LTE Band 4	5MHz : 0.29W 10MHz : 0.36W
CATEGORY	LTE: 3	
ANTENNA TYPE	LTE Band 17: Internal monopole antenna with -4.5dBi gain LTE Band 4: Internal monopole antenna with -1dBi gain	
DATA CABLE	Refer to users' manual	
I/O PORTS	Refer to Note as below	
ACCESSORY DEVICES	Refer to Note as below	

NOTE:

1. The EUT's accessories list refers to Ext Pho_NM8PJ83100.
2. The above EUT information is declared by manufacturer and for more detailed features description, please refer to the manufacturer's specifications or User's Manual.

3.2 DESCRIPTION OF TEST MODES

LTE Band 17:

Three channels had been tested for each channel bandwidth.

CHANNEL BANDWIDTH	5MHz		10MHz	
	Channel	Frequency(MHz)	Channel	Frequency(MHz)
Low channel (L)	23755	706.5	23780	709.0
Middle channel (M)	23790	710.0	23790	710.0
High channel (H)	23825	713.5	23800	711.0

LTE Band 4:

Three channels had been tested for each channel bandwidth.

CHANNEL BANDWIDTH	5MHz		10MHz	
	Channel	Frequency(MHz)	Channel	Frequency(MHz)
Low channel (L)	19975	1712.5	20000	1715.0
Middle channel (M)	20175	1732.5	20175	1732.5
High channel (H)	20375	1752.5	20350	1750.0

3.2.1 CONFIGURATION OF SYSTEM UNDER TEST

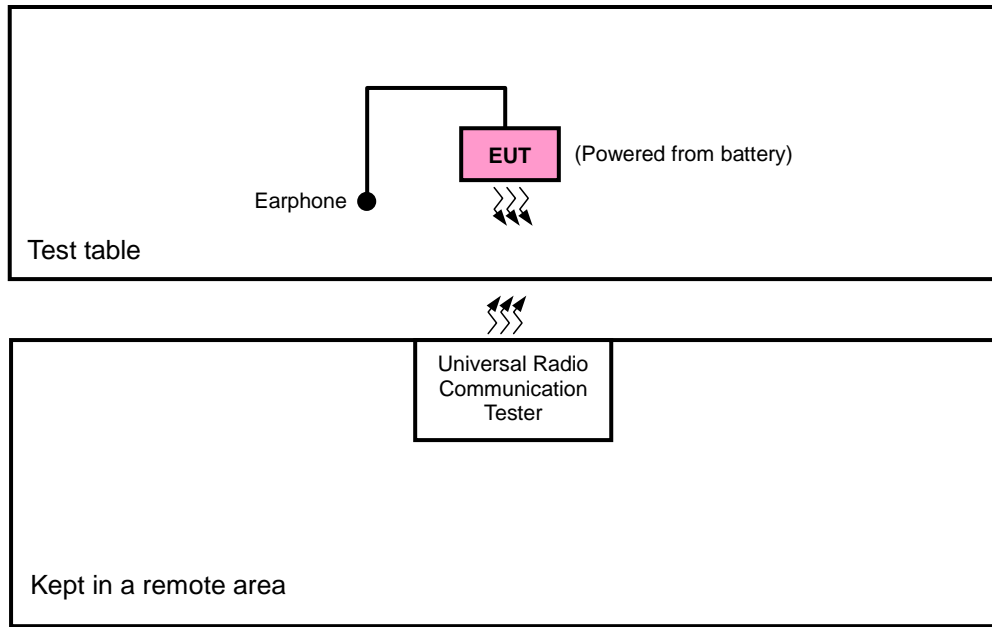

3.2.2 TEST MODE APPLICABILITY AND TESTED CHANNEL DETAIL

EUT CONFIGURE MODE	APPLICABLE TO							DESCRIPTION
	OP	FS	OB	PA	BE	CE	RE	
-	V	V	V	V	V	V	V	-

Where **OP**: Output power **FS**: Frequency stability
OB: Occupied bandwidth **PA**: Peak to Average Ratio
BE: Band edge **CE**: Conducted spurious emissions
RE: Radiated emission

OUTPUT POWER MEASUREMENT:

- Pre-Scan has been conducted to determine the worst-case mode from all possible combinations between available modulations, XYZ axis and antenna ports (if EUT with antenna diversity architecture).
- Following channel(s) was (were) selected for the final test as listed below.

EUT CONFIGURE MODE	OPERATING BAND	AVAILABLE CHANNEL	TESTED CHANNEL	CHANNEL BANDWIDTH	MODULATION TECHNOLOGY	AXIS
-	LTE Band 17	23780 to 23800	23780, 23790, 23800	5MHz 10MHz	QPSK	Y
-	LTE Band 4	20000 to 20350	20000, 20175, 20350	5MHz 10MHz	QPSK	Y

FREQUENCY STABILITY MEASUREMENT:

- Pre-Scan has been conducted to determine the worst-case mode from all possible combinations between available modulations and antenna ports (if EUT with antenna diversity architecture).
- Following channel(s) was (were) selected for the final test as listed below.

EUT CONFIGURE MODE	OPERATING BAND	AVAILABLE CHANNEL	TESTED CHANNEL	MODULATION TECHNOLOGY
-	LTE Band 17	23755 to 23825	23790	QPSK
-		23780 to 23800	23790	QPSK
-	LTE Band 4	19975 to 20375	20175	QPSK
-		20000 to 20350	20175	QPSK

OCCUPIED BANDWIDTH MEASUREMENT:

- This item includes all test value of each mode, but only includes spectrum plot of worst value of each mode.
- Pre-Scan has been conducted to determine the worst-case mode from all possible combinations between available modulations and antenna ports (if EUT with antenna diversity architecture).
- Following channel(s) was (were) selected for the final test as listed below.

EUT CONFIGURE MODE	OPERATING BAND	AVAILABLE CHANNEL	TESTED CHANNEL	MODULATION TECHNOLOGY
-	LTE Band 17	23755 to 23825	23790	QPSK, 16QAM
-		23780 to 23800	23790	QPSK, 16QAM
-	LTE Band 4	19975 to 20375	20175	QPSK, 16QAM
-		20000 to 20350	20175	QPSK, 16QAM

PEAK TO AVERAGE RATIO:

- This item includes all test value of each mode, but only includes spectrum plot of worst value of each mode.
- Pre-Scan has been conducted to determine the worst-case mode from all possible combinations between available modulations, XYZ axis and antenna ports (if EUT with antenna diversity architecture).
- Following channel(s) was (were) selected for the final test as listed below.

EUT CONFIGURE MODE	OPERATING BAND	AVAILABLE CHANNEL	TESTED CHANNEL	MODULATION TECHNOLOGY
-	LTE Band 17	23755 to 23825	23755, 23790, 23825	QPSK, 16QAM
-		23780 to 23800	23780, 23790, 23800	QPSK, 16QAM
-	LTE Band 4	19975 to 20375	19975, 20175, 20375	QPSK, 16QAM
-		20000 to 20350	20000, 20175, 20350	QPSK, 16QAM

BAND EDGE MEASUREMENT:

- Pre-Scan has been conducted to determine the worst-case mode from all possible combinations between available modulations, XYZ axis and antenna ports (if EUT with antenna diversity architecture).
- Following channel(s) was (were) selected for the final test as listed below.

EUT CONFIGURE MODE	OPERATING BAND	AVAILABLE CHANNEL	TESTED CHANNEL	MODULATION TECHNOLOGY
-	LTE Band 17	23755 to 23825	23755, 23825	QPSK
-		23780 to 23800	23780, 23800	QPSK
-	LTE Band 4	19975 to 20375	19975, 20375	QPSK
-		20000 to 20350	20000, 20350	QPSK

CONDUCTED SPURIOUS EMISSIONS MEASUREMENT:

- Pre-Scan has been conducted to determine the worst-case mode from all possible combinations between available modulations and antenna ports (if EUT with antenna diversity architecture).
- Following channel(s) was (were) selected for the final test as listed below.

EUT CONFIGURE MODE	OPERATING BAND	AVAILABLE CHANNEL	TESTED CHANNEL	MODULATION TECHNOLOGY
-	LTE Band 17	23755 to 23825	23755, 23790, 23825	QPSK
-		23780 to 23800	23780, 23790, 23800	QPSK
-	LTE Band 4	19975 to 20375	19975, 20175, 20375	QPSK
-		20000 to 20350	20000, 20175, 20350	QPSK

RADIATED EMISSION MEASUREMENT:

- Pre-Scan has been conducted to determine the worst-case mode from all possible combinations between available modulations, XYZ axis and antenna ports (if EUT with antenna diversity architecture).
- Following channel(s) was (were) selected for the final test as listed below.

EUT CONFIGURE MODE	OPERATING BAND	AVAILABLE CHANNEL	TESTED CHANNEL	MODULATION TECHNOLOGY	AXIS
-	LTE Band 17	23755 to 23825	23790	QPSK	X
-		23780 to 23800	23790	QPSK	X
-	LTE Band 4	19975 to 20375	20175	QPSK	X
-		20000 to 20350	20175	QPSK	X

TEST CONDITION:

APPLICABLE TO	ENVIRONMENTAL CONDITIONS	INPUT POWER (SYSTEM)	TESTED BY
OP	25deg. C, 53%RH	3.8Vdc	Phoenix Chen
FS	25deg. C, 53%RH	3.8Vdc	Phoenix Chen
OB	25deg. C, 53%RH	3.8Vdc	Phoenix Chen
PA	25deg. C, 53%RH	3.8Vdc	Phoenix Chen
BE	25deg. C, 53%RH	3.8Vdc	Phoenix Chen
CE	25deg. C, 53%RH	3.8Vdc	Phoenix Chen
RE	25deg. C, 65%RH	120Vac, 60Hz	Kay Wu

3.3 GENERAL DESCRIPTION OF APPLIED STANDARDS

The EUT is a RF product. According to the specifications of the manufacturer, it must comply with the requirements of the following standards:

FCC 47 CFR Part 2

FCC 47 CFR Part 27

ANSI C63.4-2003

ANSI/TIA/EIA-603-C 2004

NOTE: All test items have been performed and recorded as per the above standards.

3.4 DESCRIPTION OF SUPPORT UNITS

The EUT has been tested as an independent unit together with other necessary accessories or support units. The following support units or accessories were used to form a representative test configuration during the tests.

NO.	PRODUCT	BRAND	MODEL NO.	SERIAL NO.	FCC ID
1	UNIVERSAL RADIO COMMUNICATION TESTER	R&S	CMU200	104484	NA
2	Radio Communication Analyzer	Anritsu	MT8820C	6201010284	NA

NO.	SIGNAL CABLE DESCRIPTION OF THE ABOVE SUPPORT UNITS
1	NA
2	NA

NOTE:

1. All power cords of the above support units are non shielded (1.8m).
2. Item 1-2 acted as a communication partners to transfer data.

4 TEST TYPES AND RESULTS

4.1 OUTPUT POWER MEASUREMENT

4.1.1 LIMITS OF OUTPUT POWER MEASUREMENT

Fixed, mobile, and portable (hand-held) stations operating in the 1710–1755 MHz band are limited to 1 watt EIRP.

Portable stations (hand-held devices) operating in the 704-716 MHz band are limited to 3 watts ERP

4.1.2 TEST INSTRUMENTS

DESCRIPTION & MANUFACTURER	MODEL NO.	SERIAL NO.	DATE OF CALIBRATION	DUE DATE OF CALIBRATION
Test Receiver ROHDE & SCHWARZ	ESCI	100744	Apr. 19, 2011	Apr. 18, 2012
Spectrum Analyzer ROHDE & SCHWARZ	FSP40	100040	Aug. 04, 2011	Aug. 03, 2012
BILOG Antenna SCHWARZBECK	VULB9168	9168-156	Apr. 12, 2011	Apr. 11, 2012
HORN Antenna SCHWARZBECK	BBHA 9120 D	9120D-563	Sep. 06, 2011	Sep. 05, 2012
HORN Antenna SCHWARZBECK	BBHA 9170	148	Jul. 20, 2011	Jul. 19, 2012
Preamplifier Agilent	8449B	3008A01911	Oct. 29, 2011	Oct. 28, 2012
Preamplifier Agilent	8447D	2944A10638	Oct. 29, 2011	Oct. 28, 2012
RF signal cable HUBER+SUHNNER	SUCOFLEX 104	295013/4 283403/4	Aug. 19, 2011	Aug. 18, 2012
RF signal cable Worken	8D-FB	Cable-HYCH9-01	Aug. 13, 2011	Aug. 12, 2012
Software	ADT_Radiated_ V7.6.15.9.2	NA	NA	NA
Antenna Tower EMCO	2070/2080	512.835.4684	NA	NA
Turn Table EMCO	2087-2.03	NA	NA	NA
Antenna Tower & Turn Table Controller EMCO	2090	NA	NA	NA

- NOTE:**
1. The calibration interval of the above test instruments is 12 months and the calibrations are traceable to NML/ROC and NIST/USA.
 2. The test was performed in HwaYa Chamber 9.
 3. The horn antenna and HP preamplifier (model: 8449B) are used only for the measurement of emission frequency above 1GHz if tested.
 4. The FCC Site Registration No. is 460141.
 5. The IC Site Registration No. is IC 7450F-4.

4.1.3 TEST PROCEDURES

EIRP / ERP MEASUREMENT:

- a. The EUT was set up for the maximum power with LTE link data modulation. The power was measured with R&S Spectrum Analyzer. All measurements were done at 3 channels (low, middle and high operational frequency range). RWB and VBW is 10MHz for LTE.
- b. E.I.R.P power measurement. In the semi-anechoic chamber, EUT placed on the 0.8m height of Turn Table, rotated the table around 360 degrees to search the maximum radiation power and receiver antenna shall be rotated vertical and horizontal polarization and moved height from 1m to 4m to find the maximum polar radiated power. The "Read Value" is the spectrum reading the maximum power value.
- c. The substitution horn antenna is substituted for EUT at the same position and signals generator export the CW signal to the substitution antenna via a TX cable. Rotated the Turn Table and moved receiving antenna to find the maximum radiation power. Adjust output power level of S.G to get a Value of spectrum reading equal to "Read Value" of step a. Record the power level of S.G
- d. $EIRP = \text{Output power level of S.G} - \text{TX cable loss} + \text{Antenna gain of substitution horn}$
- e. $E.R.P = E.I.R.P - 2.15 \text{ dB}$

CONDUCTED POWER MEASUREMENT:

- a. The EUT was set up for the maximum power with LTE link data modulation and link up with simulator.
- b. Set the EUT to transmit under low, middle and high channel and record the power level shown on simulator.

4.1.4 TEST SETUP

EIRP / ERP MEASUREMENT:

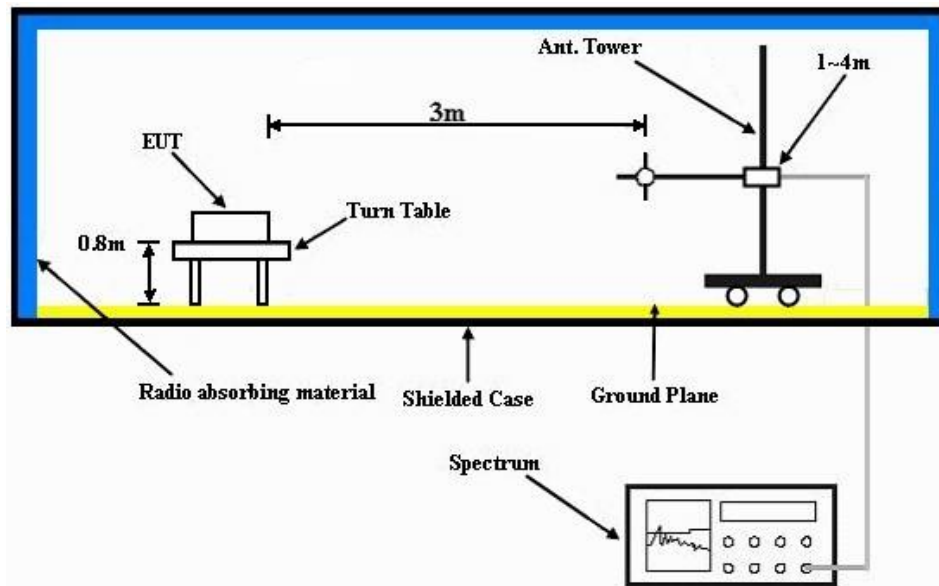

For the actual test configuration, please refer to the attached file (Test Setup Photo).

CONDUCTED POWER MEASUREMENT:

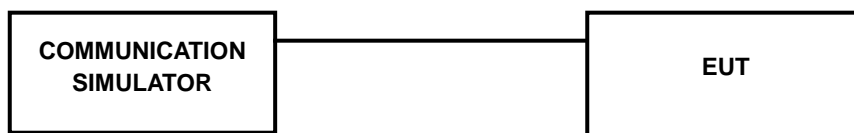

For the actual test configuration, please refer to the attached file (Test Setup Photo).

4.1.5 EUT OPERATING CONDITIONS

- a. The EUT makes a call to the communication simulator.
- b. The communication simulator station system controlled an EUT to export maximum output power under transmission mode and specific channel frequency.

4.1.6 TEST RESULTS

CONDUCTED OUTPUT POWER (dBm)

LTE Band 17								
BW	Modulation	CH	Frequency	RB	RB Offset	MPR	Target	Measured
			(MHz)				Power	Power
5 MHz	QPSK	23755	706.5	1	0	0	23.5	22.91
		23790	710	1	0	0	23.5	22.95
		23825	713.5	1	0	0	23.5	23.12
		23755	706.5	1	24	0	23.5	22.93
		23790	710	1	24	0	23.5	22.85
		23825	713.5	1	24	0	23.5	22.79
		23755	706.5	12	6	1	23.5	21.95
		23790	710	12	6	1	23.5	22.14
		23825	713.5	12	6	1	23.5	22.09
		23755	706.5	25	0	1	23.5	22.12
		23790	710	25	0	1	23.5	22.05
		23825	713.5	25	0	1	23.5	22.17
	16QAM	23755	706.5	1	0	1	23.5	22.03
		23790	710	1	0	1	23.5	22.10
		23825	713.5	1	0	1	23.5	22.26
		23755	706.5	1	24	1	23.5	22.11
		23790	710	1	24	1	23.5	22.09
		23825	713.5	1	24	1	23.5	21.88
		23755	706.5	12	6	2	23.5	21.06
		23790	710	12	6	2	23.5	21.09
		23825	713.5	12	6	2	23.5	20.94
		23755	706.5	25	0	2	23.5	21.50
		23790	710	25	0	2	23.5	21.56
		23825	713.5	25	0	2	23.5	21.28

LTE Band 17								
BW	Modulation	CH	Frequency	RB	RB Offset	MPR	Target	Measured
			(MHz)				Power	Power
10 MHz	QPSK	23780	709	1	0	0	23.5	22.85
		23790	710	1	0	0	23.5	22.95
		23800	711	1	0	0	23.5	23.15
		23780	709	1	49	0	23.5	22.83
		23790	710	1	49	0	23.5	23.03
		23800	711	1	49	0	23.5	23.19
		23780	709	25	12	1	23.5	22.15
		23790	710	25	12	1	23.5	22.01
		23800	711	25	12	1	23.5	22.04
		23780	709	50	0	1	23.5	21.99
		23790	710	50	0	1	23.5	21.97
		23800	711	50	0	1	23.5	22.02
	16QAM	23780	709	1	0	1	23.5	21.97
		23790	710	1	0	1	23.5	22.03
		23800	711	1	0	1	23.5	22.04
		23780	709	1	49	1	23.5	22.10
		23790	710	1	49	1	23.5	22.14
		23800	711	1	49	1	23.5	22.16
		23780	709	25	12	2	23.5	21.46
		23790	710	25	12	2	23.5	21.39
		23800	711	25	12	2	23.5	21.48
		23780	709	50	0	2	23.5	21.13
		23790	710	50	0	2	23.5	21.03
		23800	711	50	0	2	23.5	21.16



A D T

LTE Band 4								
BW	Modulation	CH	Frequency	RB	RB Offset	MPR	Target	Measured
			(MHz)				Power	Power
5 MHz	QPSK	19975	1712.5	1	0	0	23.5	23.36
		20175	1732.5	1	0	0	23.5	23.15
		20375	1752.5	1	0	0	23.5	23.03
		19975	1712.5	1	24	0	23.5	23.35
		20175	1732.5	1	24	0	23.5	23.07
		20375	1752.5	1	24	0	23.5	23.17
		19975	1712.5	12	6	1	23.5	22.42
		20175	1732.5	12	6	1	23.5	22.01
		20375	1752.5	12	6	1	23.5	22.11
		19975	1712.5	25	0	1	23.5	22.55
		20175	1732.5	25	0	1	23.5	22.14
		20375	1752.5	25	0	1	23.5	22.23
	16QAM	19975	1712.5	1	0	1	23.5	22.52
		20175	1732.5	1	0	1	23.5	22.17
		20375	1752.5	1	0	1	23.5	22.17
		19975	1712.5	1	24	1	23.5	22.46
		20175	1732.5	1	24	1	23.5	22.07
		20375	1752.5	1	24	1	23.5	22.22
		19975	1712.5	12	6	2	23.5	21.20
		20175	1732.5	12	6	2	23.5	20.82
		20375	1752.5	12	6	2	23.5	20.90
		19975	1712.5	25	0	2	23.5	21.61
		20175	1732.5	25	0	2	23.5	21.28
		20375	1752.5	25	0	2	23.5	21.38



A D T

LTE Band 4								
BW	Modulation	CH	Frequency	RB	RB Offset	MPR	Target	Measured
			(MHz)				Power	Power
10 MHz	QPSK	20000	1715	1	0	0	23.5	23.46
		20175	1732.5	1	0	0	23.5	23.28
		20350	1750	1	0	0	23.5	23.20
		20000	1715	1	49	0	23.5	23.25
		20175	1732.5	1	49	0	23.5	23.09
		20350	1750	1	49	0	23.5	23.14
		20000	1715	25	12	1	23.5	22.50
		20175	1732.5	25	12	1	23.5	22.17
		20350	1750	25	12	1	23.5	22.08
		20000	1715	50	0	1	23.5	22.55
		20175	1732.5	50	0	1	23.5	22.19
		20350	1750	50	0	1	23.5	22.10
	16QAM	20000	1715	1	0	1	23.5	22.56
		20175	1732.5	1	0	1	23.5	22.27
		20350	1750	1	0	1	23.5	22.18
		20000	1715	1	49	1	23.5	22.34
		20175	1732.5	1	49	1	23.5	22.14
		20350	1750	1	49	1	23.5	22.22
		20000	1715	25	12	2	23.5	21.61
		20175	1732.5	25	12	2	23.5	21.27
		20350	1750	25	12	2	23.5	21.19
		20000	1715	50	0	2	23.5	21.43
		20175	1732.5	50	0	2	23.5	21.14
		20350	1750	50	0	2	23.5	21.05

FOR LTE BAND 17:

CHANNEL BANDWIDTH: 5MHz

Plane	Channel	Frequency (MHz)	LVL (dBm)	Correction Factor(dB)	ERP(dBm)	ERP(W)	Polarization (H/V)
Y	23780	706.5	-11.42	30.36	16.79	0.05	H
	23790	710.0	-11.87	30.17	16.15	0.04	H
	23800	713.5	-11.27	30.17	16.75	0.05	H
	23780	706.5	-18.75	32.03	11.13	0.01	V
	23790	710.0	-17.86	31.98	11.97	0.02	V
	23800	713.5	-18.06	32.06	11.85	0.02	V

FOR LTE BAND 4:

CHANNEL BANDWIDTH: 5MHz

Plane	Channel	Frequency (MHz)	LVL (dBm)	Correction Factor(dB)	EIRP(dBm)	EIRP(W)	Polarization (H/V)
Y	20000	1712.4	-15.98	37.90	21.92	0.16	H
	20175	1732.6	-15.71	37.99	22.28	0.17	H
	20350	1752.6	-15.51	38.31	22.80	0.19	H
	20000	1712.4	-13.21	37.81	24.60	0.29	V
	20175	1732.6	-13.98	37.40	23.42	0.22	V
	20350	1752.6	-13.99	38.22	24.23	0.26	V



A D T

FOR LTE BAND 17:

CHANNEL BANDWIDTH: 10MHz

Plane	Channel	Frequency (MHz)	LVL (dBm)	Correction Factor(dB)	ERP(dBm)	ERP(W)	Polarization (H/V)
Y	23780	709.0	-12.71	30.02	15.16	0.03	H
	23790	710.0	-12.67	29.96	15.14	0.03	H
	23800	711.0	-13.07	29.91	14.69	0.03	H
	23780	709.0	-18.72	33.52	12.65	0.02	V
	23790	710.0	-19.68	33.53	11.70	0.01	V
	23800	711.0	-19.85	33.53	11.53	0.01	V

FOR LTE BAND 4:

CHANNEL BANDWIDTH: 10MHz

Plane	Channel	Frequency (MHz)	LVL (dBm)	Correction Factor(dB)	EIRP(dBm)	EIRP(W)	Polarization (H/V)
Y	20000	1715.0	-15.40	37.99	22.59	0.18	H
	20175	1732.5	-15.40	37.99	22.59	0.18	H
	20350	1750.0	-16.31	38.36	22.05	0.16	H
	20000	1715.0	-12.29	37.91	25.62	0.36	V
	20175	1732.5	-13.49	38.00	24.51	0.28	V
	20350	1750.0	-13.97	38.28	24.31	0.27	V

4.2 FREQUENCY STABILITY MEASUREMENT

4.2.1 LIMITS OF FREQUENCY STABILITY MEASUREMENT

According to the FCC part 27.54 shall be tested the frequency stability. The rule is defined that” The frequency stability shall be sufficient to ensure that the fundamental emissions stay within the authorized bands of operation.

4.2.2 TEST INSTRUMENTS

DESCRIPTION & MANUFACTURER	MODEL NO.	SERIAL NO.	DATE OF CALIBRATION	DUE DATE OF CALIBRATION
* Hewlett Packard RF cable	8120-6192	01428251	NA	NA
* Suhner RF cable	Sucoflex104	257029	Sep. 11, 2011	Sep. 10, 2012
* WIT Standard Temperature & Humidity Chamber	MHU-225AU	920842	Jun. 15, 2011	Jun. 14, 2012

- NOTE:**
1. The calibration interval of the above test instruments is 12 months. And the calibrations are traceable to NML/ROC and NIST/USA.
 2. “*” = These equipments are used for the final measurement.
 3. The test was performed in ADT RF OVEN room.

4.2.3 TEST PROCEDURE

- a. Because of the measure the carrier frequency under the condition of the AFC lock, it shall be used the mobile station in the LTE link mode. This is accomplished with the use of the communication simulator station. The oven room could control the temperatures and humidity.
- b. Power must be removed when changing from one temperature to another or one voltage to another voltage. Power warm up is at least 15 min and power applied should perform before recording frequency error.
- c. EUT is connected the external power supply to control the DC input power. The various Volts from the minimum 3.6 Volts to 4.2 Volts. Each step shall be record the frequency error rate.
- d. The temperature range step is 10 degrees in this test items. All temperature levels shall be hold the $\pm 0.5^{\circ}\text{C}$ during the measurement testing.
- e. The each temperature step shall be at least 0.5 hours, consider the EUT could be test under the stability condition.

NOTE: The frequency error was recorded frequency error from the communication simulator.

4.2.4 TEST SETUP

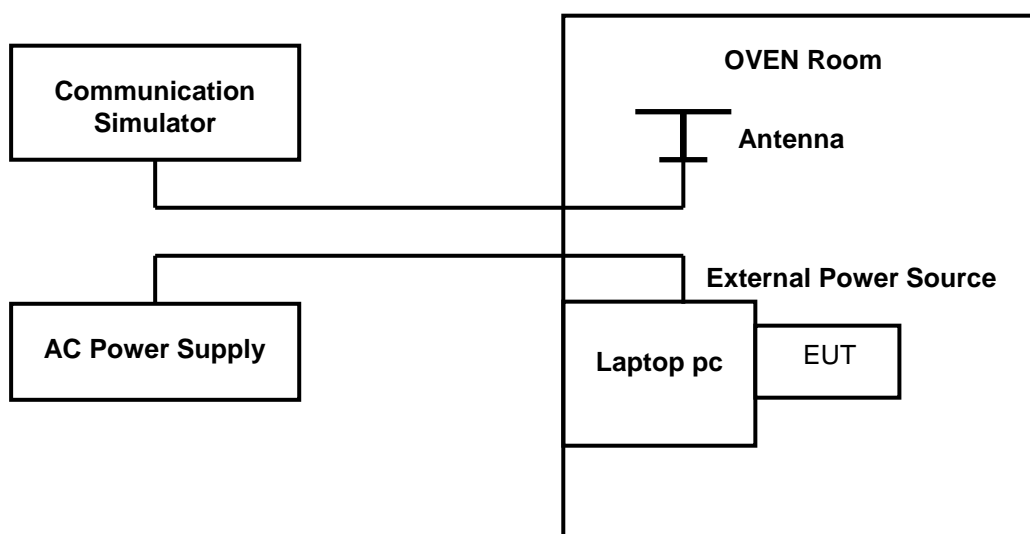

4.2.5 TEST RESULTS

FOR LTE BAND 17:

CHANNEL BANDWIDTH: 5MHz

AFC FREQUENCY ERROR vs. VOLTAGE		
VOLTAGE (Volts)	MEASURED ERROR (ppm)	LIMIT (ppm)
3.8	-0.0052	2.5
3.6	-0.0029	2.5
4.2	-0.0038	2.5

NOTE: The applicant defined the normal working voltage of the host equipment is from 3.6Vdc to 4.2Vdc.

AFC FREQUENCY ERROR vs. TEMP.		
TEMP. (°C)	MEASURED ERROR (ppm)	LIMIT (ppm)
-10	0.0024	2.5
0	0.0036	2.5
10	-0.0018	2.5
20	0.0022	2.5
30	0.0009	2.5
40	0.0013	2.5
50	-0.0031	2.5
55	-0.0045	2.5



A D T

CHANNEL BANDWIDTH: 10MHz

AFC FREQUENCY ERROR vs. VOLTAGE		
VOLTAGE (Volts)	MEASURED ERROR (ppm)	LIMIT (ppm)
3.8	0.0051	2.5
3.6	0.0040	2.5
4.2	0.0038	2.5

NOTE: The applicant defined the normal working voltage of the host equipment is from 3.6Vdc to 4.2Vdc.

AFC FREQUENCY ERROR vs. TEMP.		
TEMP. (°C)	MEASURED ERROR (ppm)	LIMIT (ppm)
-10	0.0023	2.5
0	0.0049	2.5
10	-0.0053	2.5
20	-0.0027	2.5
30	-0.0031	2.5
40	-0.0012	2.5
50	0.0019	2.5
55	-0.0035	2.5

FOR LTE BAND 4:

CHANNEL BANDWIDTH: 5MHz

AFC FREQUENCY ERROR vs. VOLTAGE		
VOLTAGE (Volts)	MEASURED ERROR (ppm)	LIMIT (ppm)
3.8	-0.0026	2.5
3.6	-0.0028	2.5
4.2	0.0028	2.5

NOTE: The applicant defined the normal working voltage of the host equipment is from 3.6Vdc to 4.2Vdc.

AFC FREQUENCY ERROR vs. TEMP.		
TEMP. (°C)	MEASURED ERROR (ppm)	LIMIT (ppm)
-10	-0.0028	2.5
0	-0.0041	2.5
10	0.0035	2.5
20	-0.0021	2.5
30	-0.0053	2.5
40	-0.0021	2.5
50	-0.0036	2.5
55	0.0048	2.5

CHANNEL BANDWIDTH: 10MHz

AFC FREQUENCY ERROR vs. VOLTAGE		
VOLTAGE (Volts)	MEASURED ERROR (ppm)	LIMIT (ppm)
3.8	-0.0026	2.5
3.6	0.0057	2.5
4.2	0.0039	2.5

NOTE: The applicant defined the normal working voltage of the host equipment is from 3.6Vdc to 4.2Vdc.

AFC FREQUENCY ERROR vs. TEMP.		
TEMP. (°C)	MEASURED ERROR (ppm)	LIMIT (ppm)
-10	-0.0024	2.5
0	-0.0028	2.5
10	-0.0035	2.5
20	-0.0019	2.5
30	-0.0050	2.5
40	-0.0042	2.5
50	-0.0038	2.5
55	-0.0047	2.5

4.3 OCCUPIED BANDWIDTH MEASUREMENT

4.3.1 LIMITS OF OCCUPIED BANDWIDTH MEASUREMENT

The width of a frequency band such that, below the lower and above the upper frequency limits, the mean powers emitted are each equal to a specified percentage 0.5 % of the total mean power of a given emission.

4.3.2 TEST INSTRUMENTS

DESCRIPTION & MANUFACTURER	MODEL NO.	SERIAL NO.	DATE OF CALIBRATION	DUE DATE OF CALIBRATION
* Mini-Circuits Power Splitter	ZAPD-4	NA	Mar. 24, 2011	Mar. 23, 2012
* Hewlett Packard RF cable	8120-6192	274388	Oct. 22, 2011	Oct. 21, 2012
* JFW 20dB attenuation	50HF-020-SMA	NA	NA	NA
* Suhner RF cable	Sucoflex104	274403/4	Aug. 20, 2011	Aug. 19, 2012
* ROHDE & SCHWARZ Spectrum Analyzer	E4446A	MY44360128	Feb. 22, 2011	Feb. 21, 2012

NOTE: 1. The calibration interval of the above test instruments is 12 months. And the calibrations are traceable to NML/ROC and NIST/USA.

2. "*" = These equipments are used for the final measurement.

4.3.3 TEST SETUP

Same as Item 4.1.4 (Conducted Power Setup)

4.3.4 TEST PROCEDURES

- a. The conducted occupied bandwidth used the power splitter via EUT RF power connector between simulation base station and spectrum analyzer.
- b. Use OBW measurement function of Spectrum analyzer to measure 99 % occupied bandwidth.

4.3.5 TEST RESULTS

LTE Band 17

CHANNEL BANDWIDTH: 5MHz / QPSK

FREQUENCY (MHz)	99% OCCUPIED BANDWIDTH (MHz)
710	4.5

CH 23790

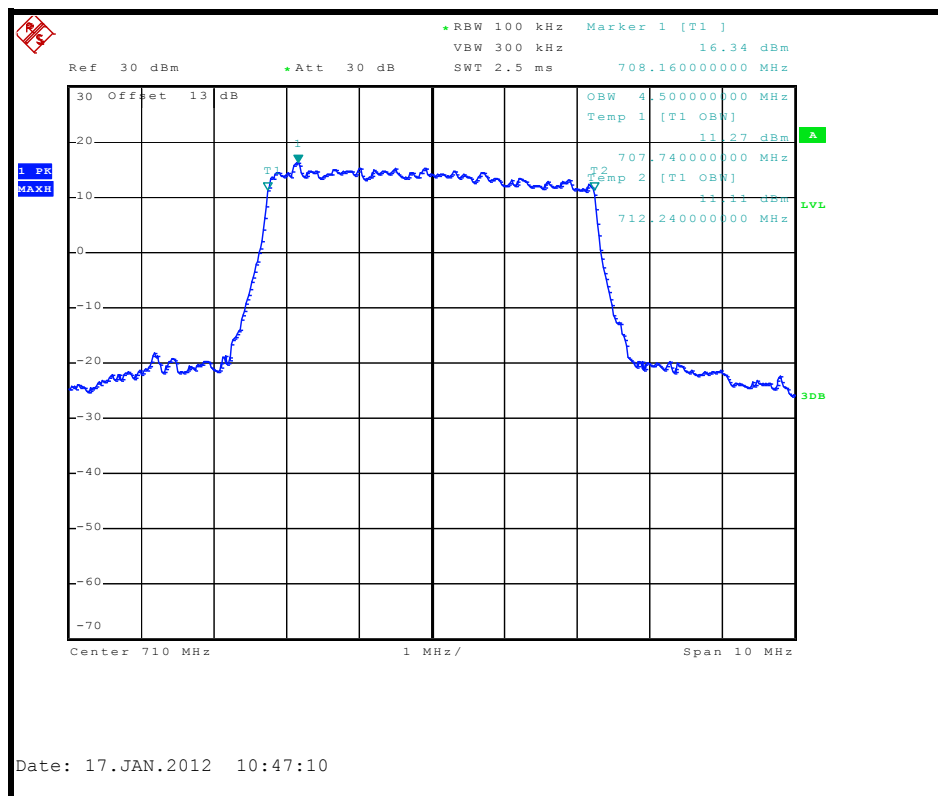



A D T

LTE Band 17

CHANNEL BANDWIDTH: 5MHz / 16QAM

FREQUENCY (MHz)	99% OCCUPIED BANDWIDTH (MHz)
710	4.5

CH 23490

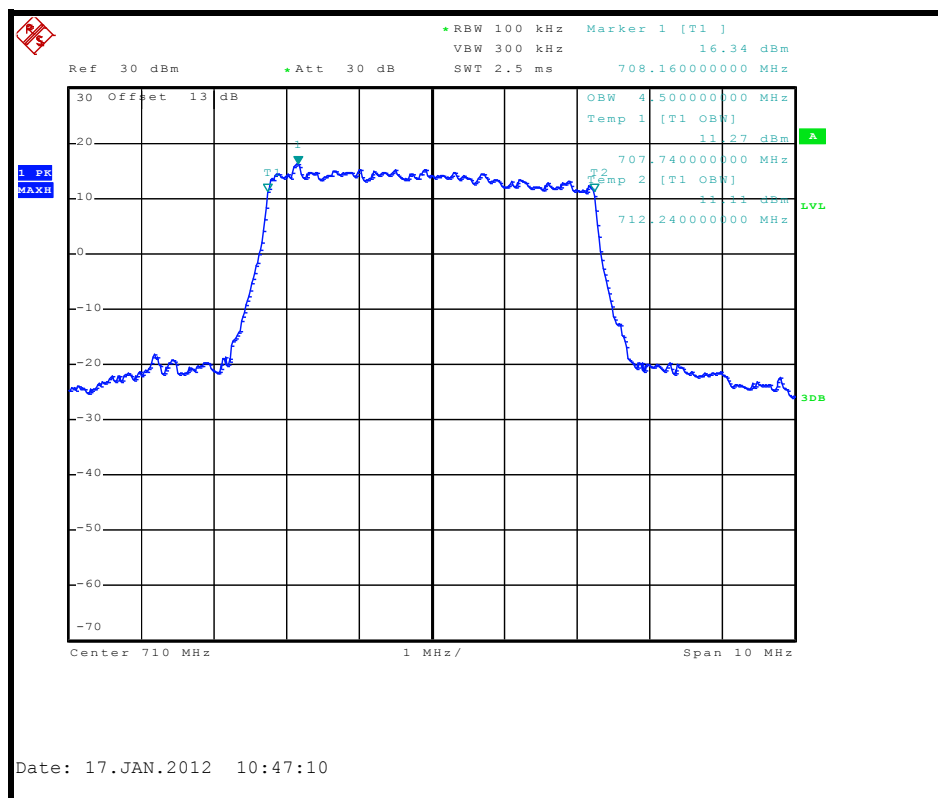



A D T

LTE Band 17 CHANNEL BANDWIDTH: 10MHz / QPSK

FREQUENCY (MHz)	99% OCCUPIED BANDWIDTH (MHz)
710	9.08

CH 23790

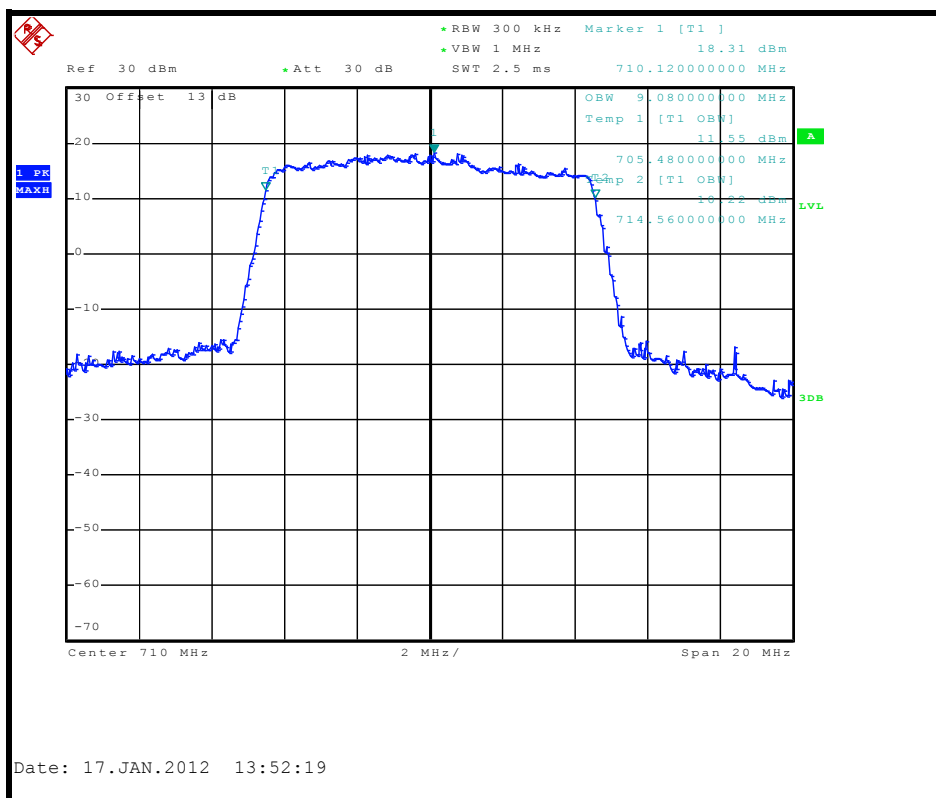



A D T

LTE Band 17

CHANNEL BANDWIDTH: 10MHz / 16QAM

FREQUENCY (MHz)	99% OCCUPIED BANDWIDTH (MHz)
710	9.04

CH 23790

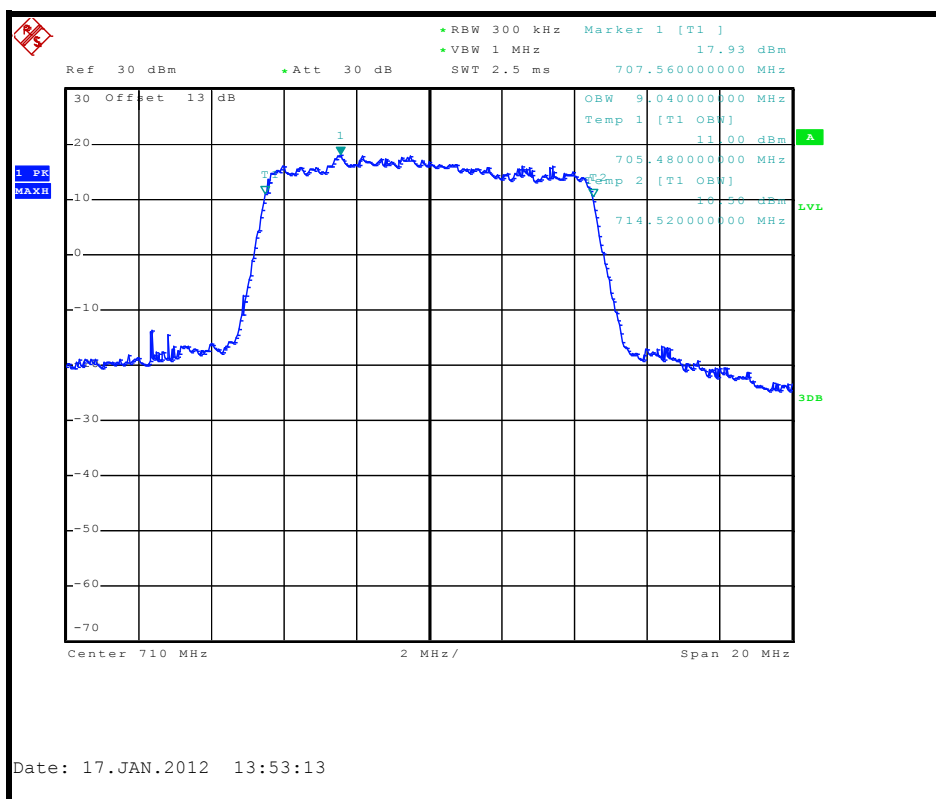

LTE Band 4

CHANNEL BANDWIDTH: 5MHz / QPSK

FREQUENCY (MHz)	99% OCCUPIED BANDWIDTH (MHz)
1732.5	4.52

CH 20175

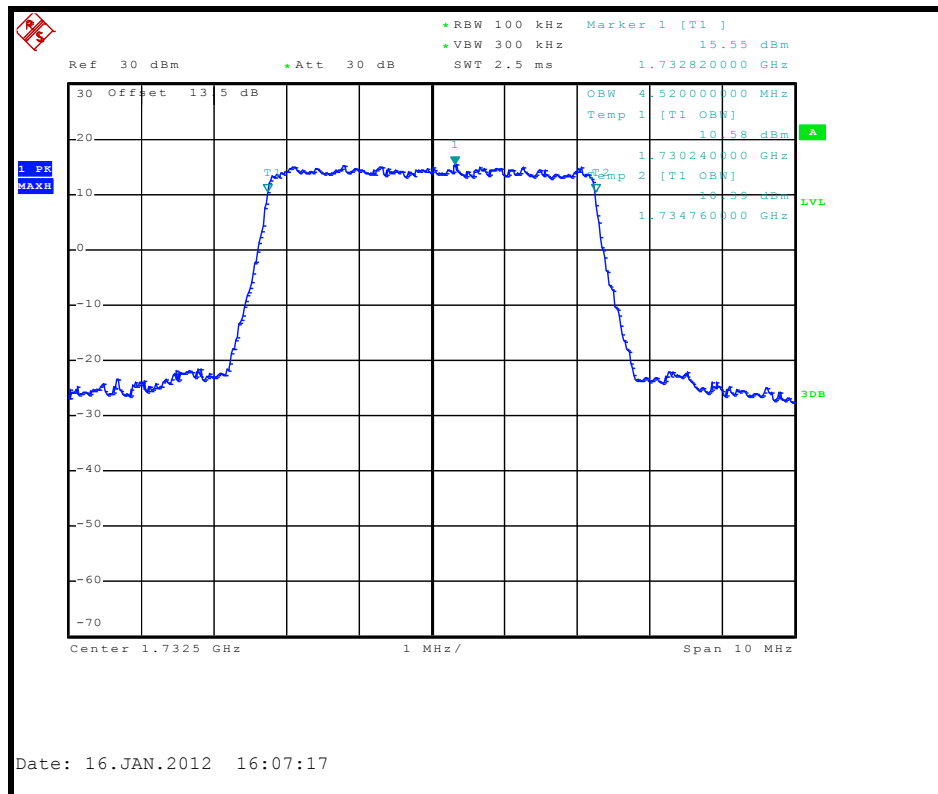

LTE Band 4

CHANNEL BANDWIDTH: 5MHz / 16QAM

FREQUENCY (MHz)	99% OCCUPIED BANDWIDTH (MHz)
1732.5	4.52

CH 20175

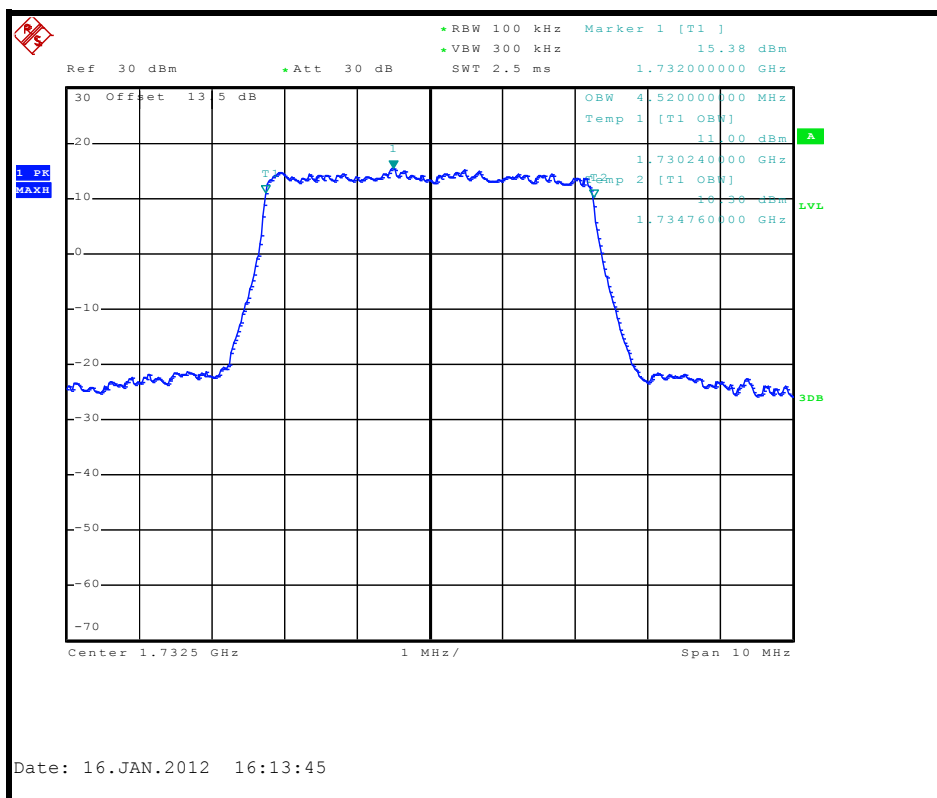



A D T

LTE Band 4

CHANNEL BANDWIDTH: 10MHz / QPSK

FREQUENCY (MHz)	99% OCCUPIED BANDWIDTH (MHz)
1732.5	9.16

CH 20175

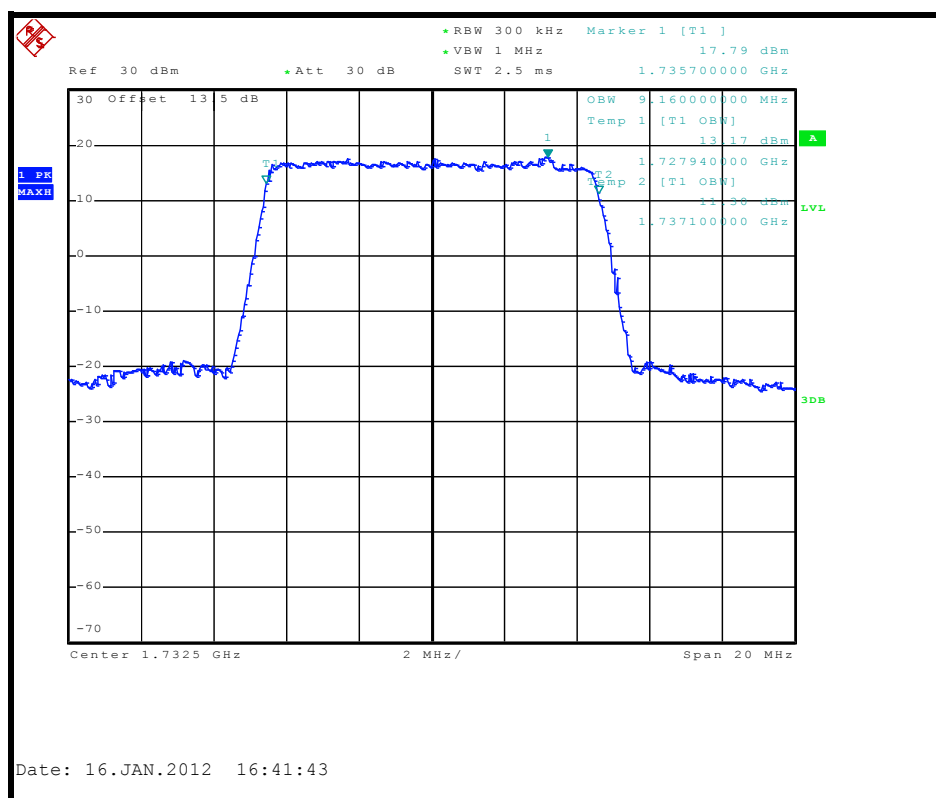

LTE Band 4

CHANNEL BANDWIDTH: 10MHz / 16QAM

FREQUENCY (MHz)	99% OCCUPIED BANDWIDTH (MHz)
1732.5	9.12

CH 20175

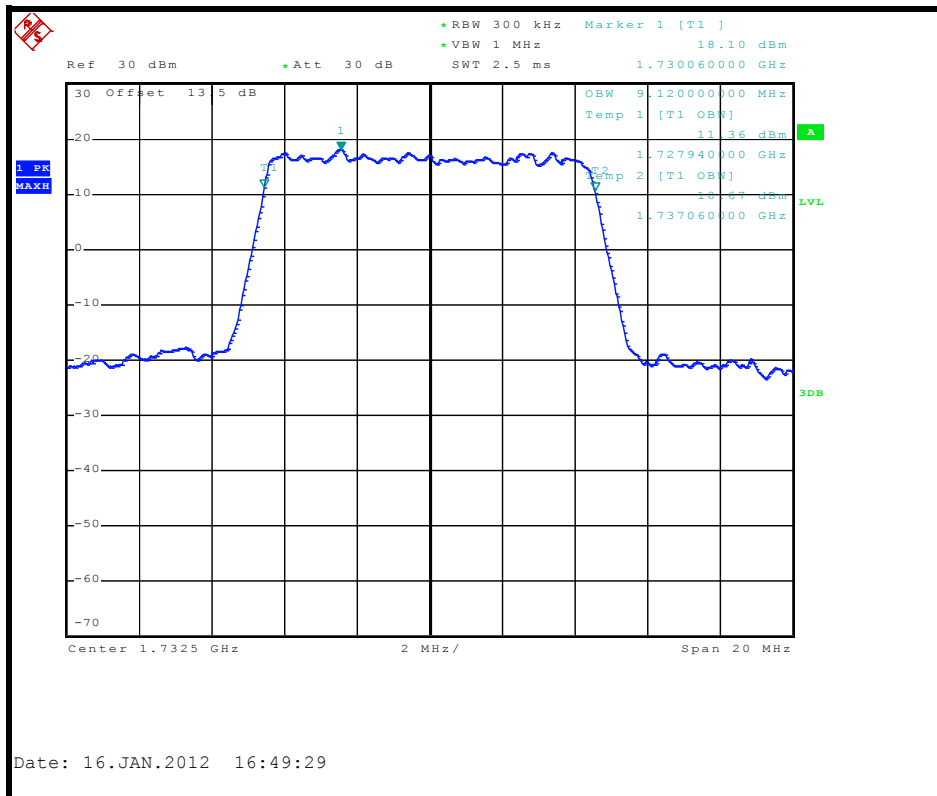

4.4 PEAK TO AVERAGE RATIO

4.4.1 LIMITS OF PEAK TO AVERAGE RATIO MEASUREMENT

In measuring transmissions in this band using an average power technique, the peak to-average ratio (PAR) of the transmission may not exceed 13 dB

4.4.2 TEST INSTRUMENTS

DESCRIPTION & MANUFACTURER	MODEL NO.	SERIAL NO.	DATE OF CALIBRATION	DUE DATE OF CALIBRATION
* ROHDE & SCHWARZ Spectrum Analyzer	FSP40	100039	Feb. 23, 2011	Feb. 22, 2012
* Agilent Spectrum Analyzer	E4446A	MY43360128	Feb. 22, 2011	Feb. 21, 2012
* Mini-Circuits Power Splitter	ZN2PD-9G	NA	May 25, 2011	May 24, 2012
* Hewlett Packard RF cable	8120-6192	274388	Oct. 22, 2011	Oct. 21, 2012
* JFW 20dB attenuation	50HF-020-SMA	NA	NA	NA
* Suhner RF cable	Sucoflex104	274403/4	Aug. 20, 2011	Aug. 19, 2012

NOTE: 1. The calibration interval of the above test instruments is 12 months. And the calibrations are traceable to NML/ROC and NIST/USA.

2. "*" = These equipments are used for the final measurement.

4.4.3 TEST SETUP

Same as Item 4.2.4 (Conducted Power Setup)

4.4.4 TEST PROCEDURES

1. Set resolution/measurement bandwidth \geq signal's occupied bandwidth;
2. Set the number of counts to a value that stabilizes the measured CCDF curve;
3. Record the maximum PAPR level associated with a probability of 0.1%.

4.4.5 EUT OPERATING CONDITION

Same as Item 4.1.5



A D T

4.4.6 TEST RESULTS

LTE Band 17

CHANNEL BANDWIDTH: 5MHz / QPSK

FREQUENCY (MHz)	PEAK TO AVERAGE RATIO (dB)
706.5	5.20
710.0	5.32
713.5	5.72

CH 23825

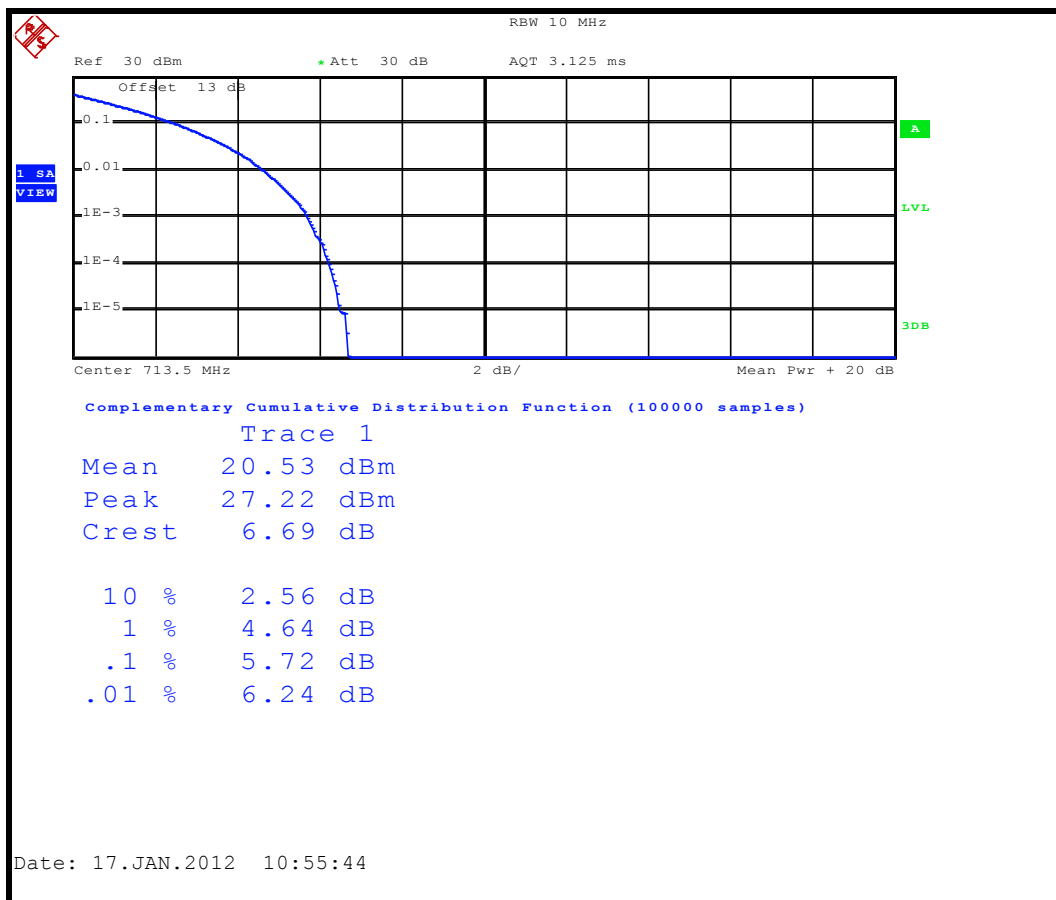



A D T

LTE Band 17

CHANNEL BANDWIDTH: 5MHz / 16QAM

FREQUENCY (MHz)	PEAK TO AVERAGE RATIO (dB)
706.5	5.72
710.0	5.92
713.5	5.32

CH 23790

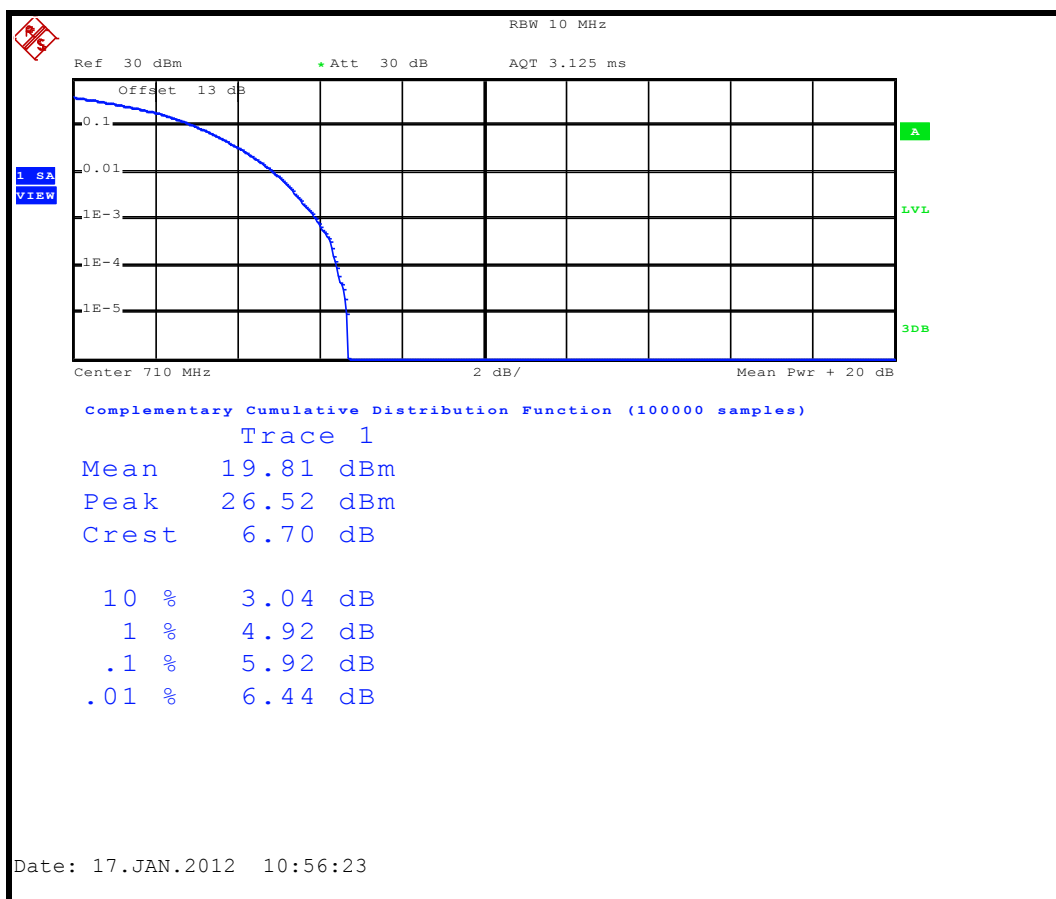



A D T

LTE Band 17

CHANNEL BANDWIDTH: 10MHz / QPSK

FREQUENCY (MHz)	PEAK TO AVERAGE RATIO (dB)
709	5.16
710	5.36
711	5.60

CH 23800

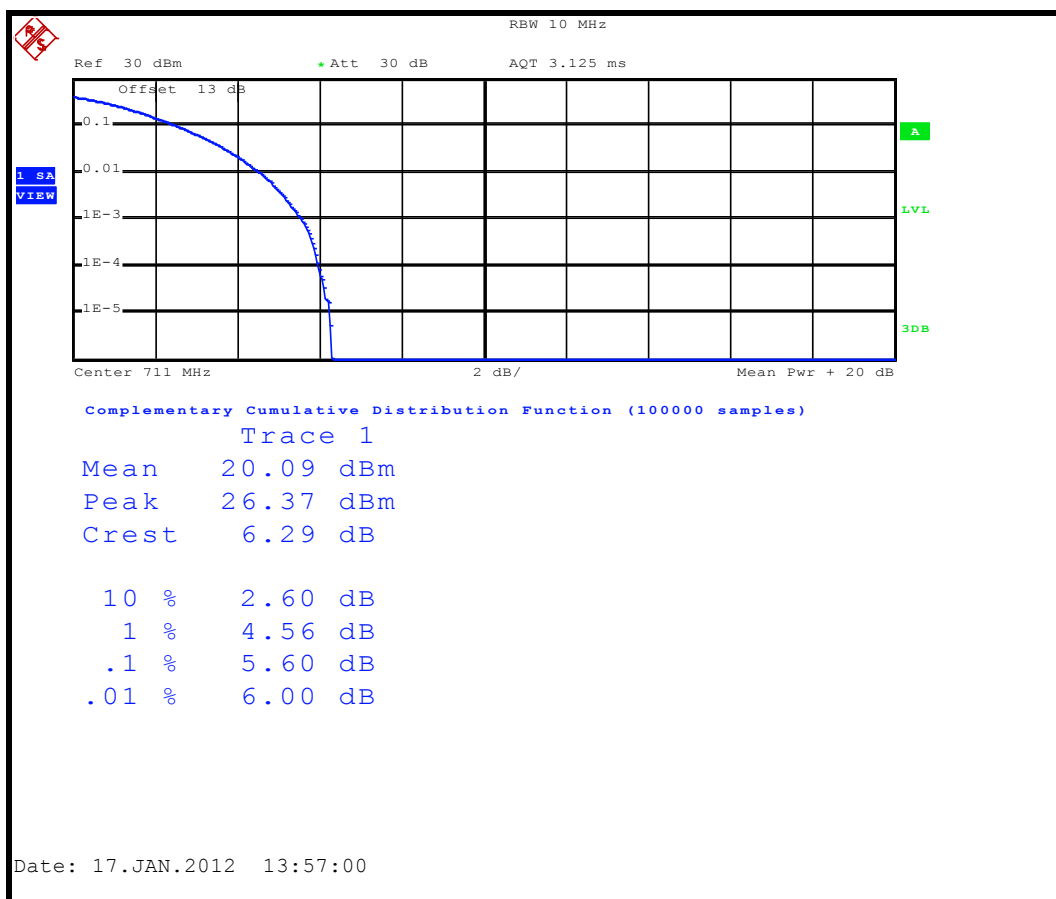



A D T

LTE Band 17

CHANNEL BANDWIDTH: 10MHz / 16QAM

FREQUENCY (MHz)	PEAK TO AVERAGE RATIO (dB)
709	6.04
710	6.12
711	6.32

CH 23800

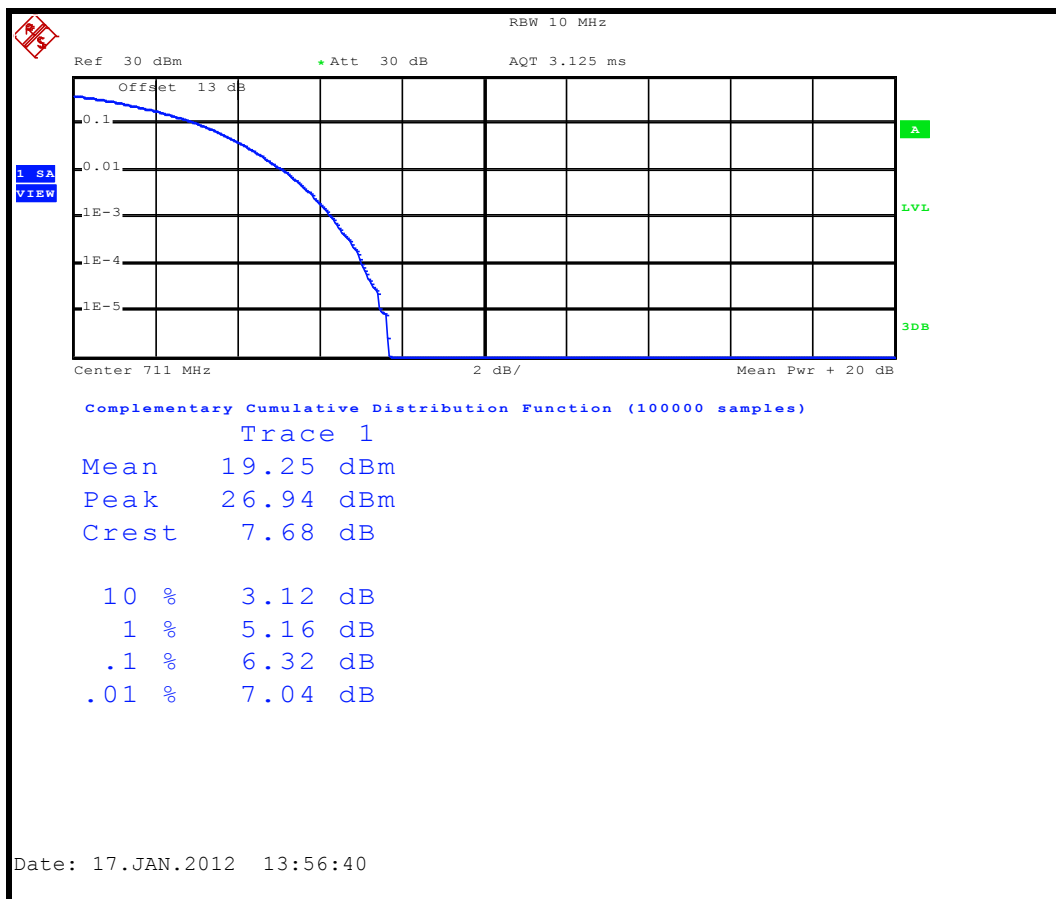



A D T

LTE Band 4

CHANNEL BANDWIDTH: 5MHz / QPSK

FREQUENCY (MHz)	PEAK TO AVERAGE RATIO (dB)
1712.5	5.90
1732.5	5.72
1752.5	5.90

CH 19975

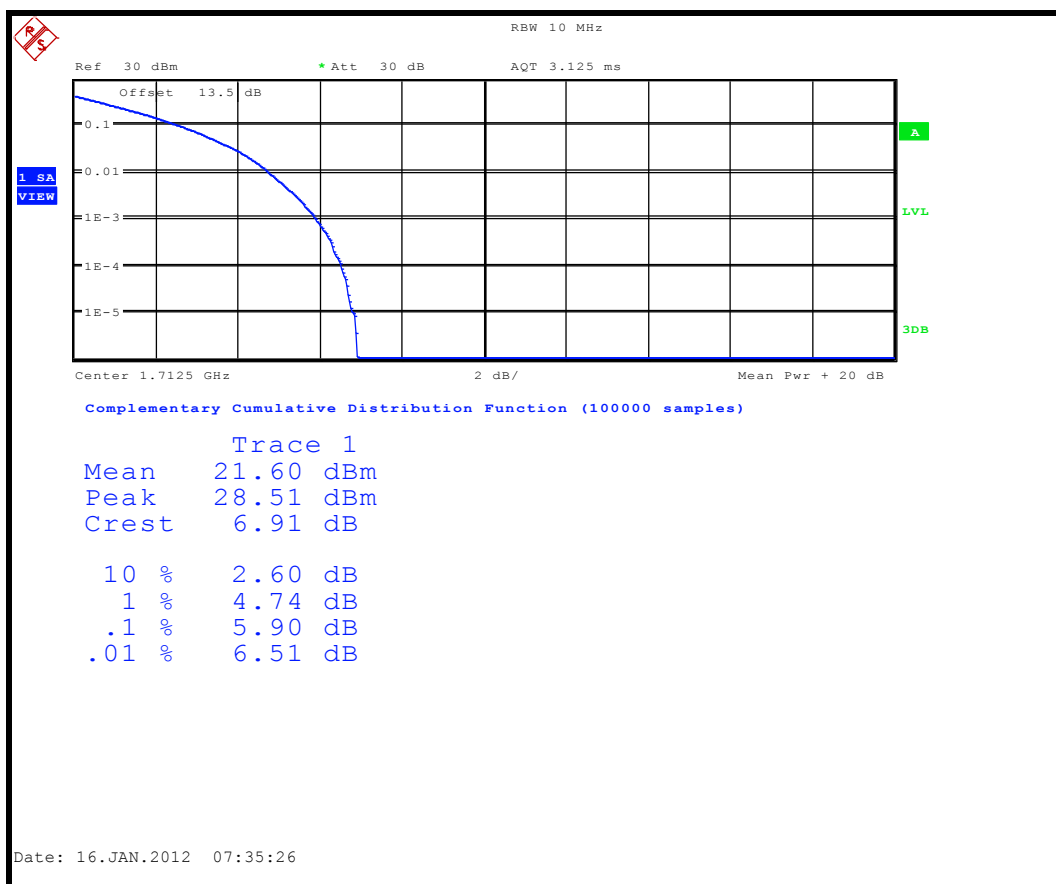

LTE Band 4

CHANNEL BANDWIDTH: 5MHz / 16QAM

FREQUENCY (MHz)	PEAK TO AVERAGE RATIO (dB)
1712.5	6.60
1732.5	6.32
1752.5	6.51

CH 19975

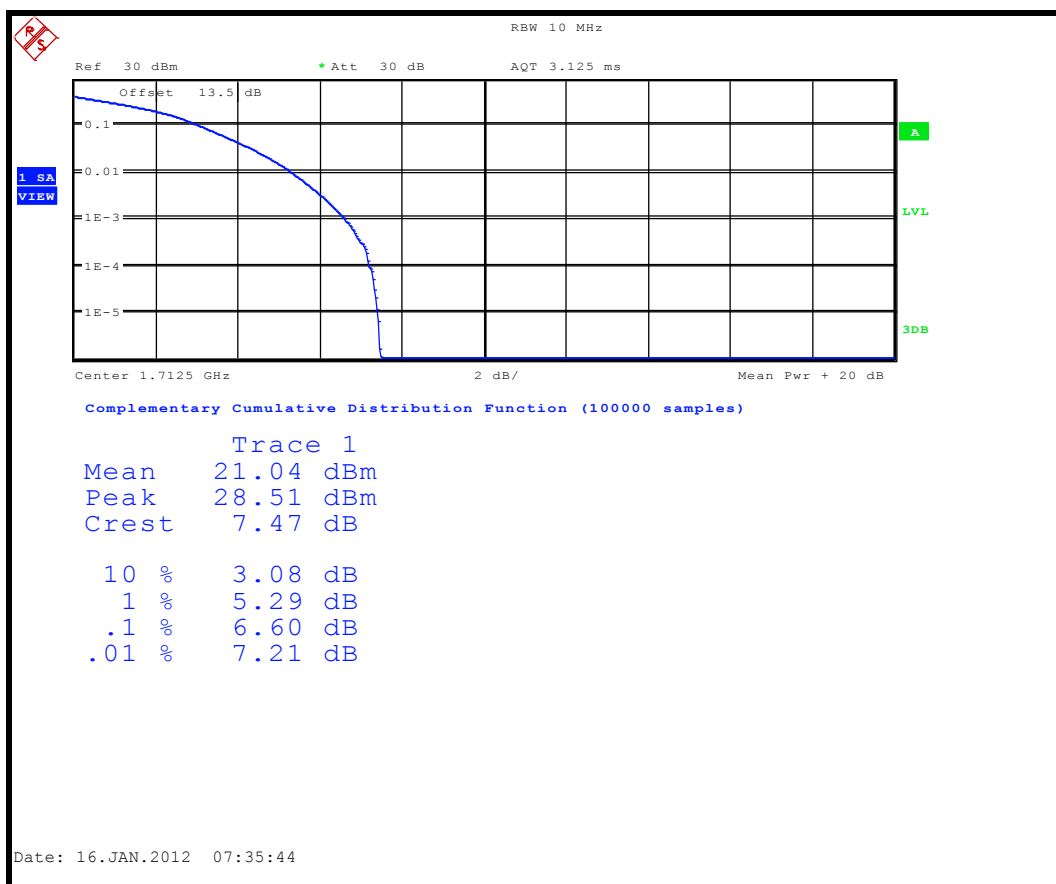



A D T

LTE Band 4

CHANNEL BANDWIDTH: 10MHz / QPSK

FREQUENCY (MHz)	PEAK TO AVERAGE RATIO (dB)
1715.0	5.72
1732.5	5.64
1750.0	5.76

CH 20350

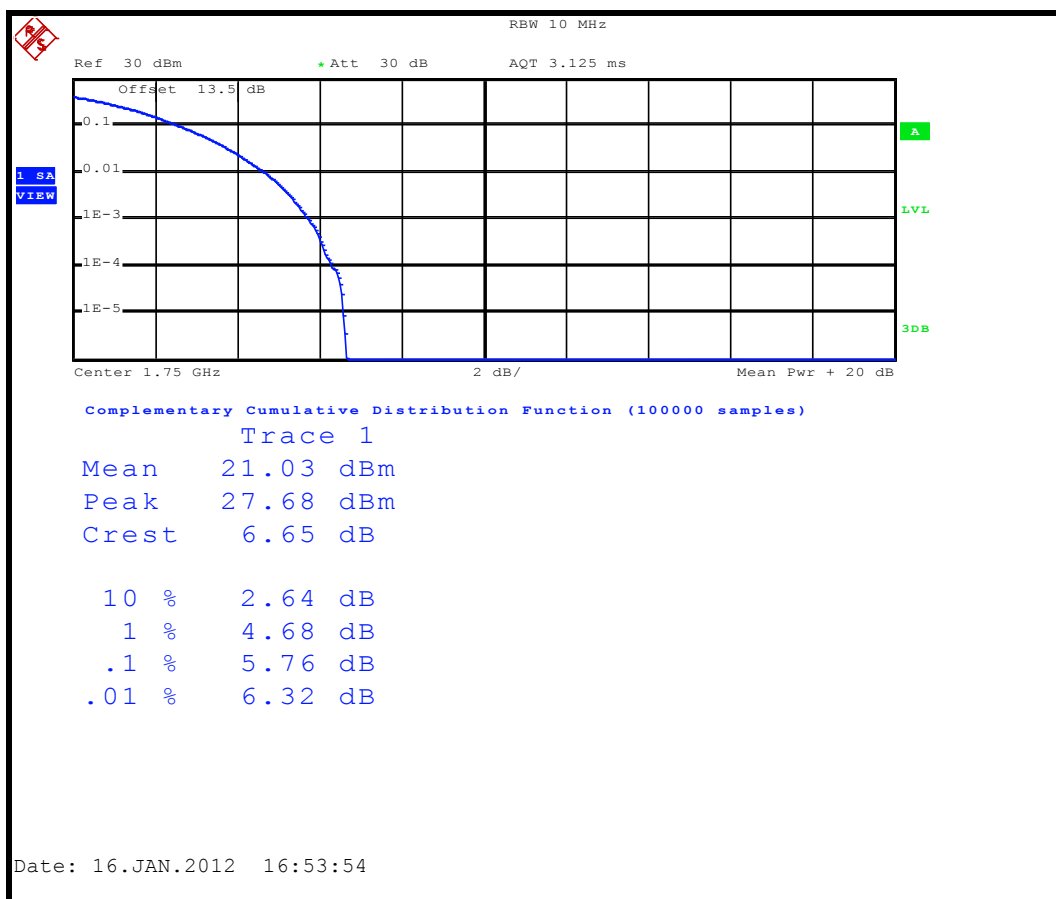



A D T

LTE Band 4

CHANNEL BANDWIDTH: 10MHz / 16QAM

FREQUENCY (MHz)	PEAK TO AVERAGE RATIO (dB)
1715.0	6.52
1732.5	6.44
1750.0	6.60

CH 20350

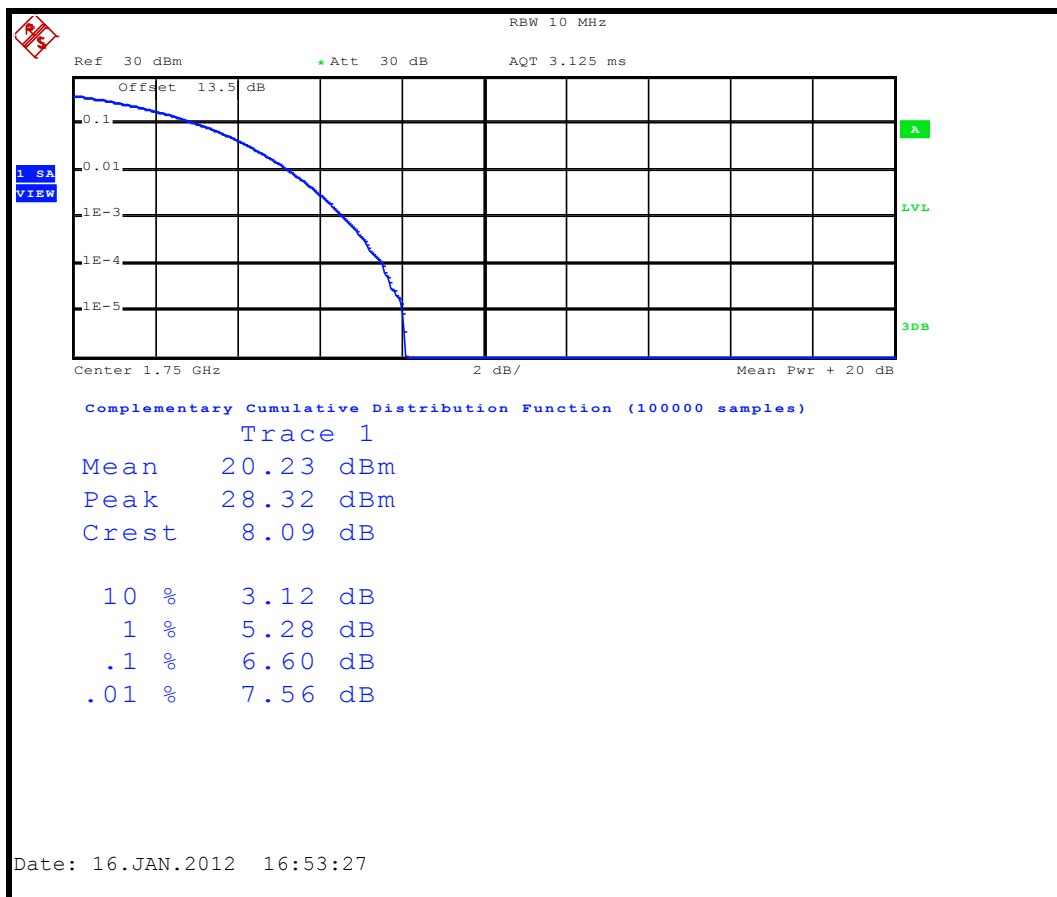

4.5 BAND EDGE MEASUREMENT

4.5.1 LIMITS OF BAND EDGE MEASUREMENT

For operations in the 704-716 MHz band, the power of any emission outside a licensee's frequency band(s) of operation shall be attenuated below the transmitter power (P) within the licensed band(s) of operation, measured in watts, by at least $43 + 10 \log (P)$ dB. Compliance with this provision is based on the use of measurement instrumentation employing a resolution bandwidth of 100 kilohertz or greater. However, in the 100 kilohertz bands immediately outside and adjacent to a licensee's frequency block, a resolution bandwidth of at least 30 kHz may be employed.

For operations in the 1710–1755 MHz band, the power of any emission outside a licensee's frequency block shall be attenuated below the transmitter power (P) by at least $43 + 10 \log_{10}(P)$ dB. The limit of emission equal to -13dBm . In the 1 MHz bands immediately outside and adjacent to the frequency block a resolution bandwidth of at least one percent of the emission bandwidth of the fundamental emission of the transmitter may be employed.

4.5.2 TEST INSTRUMENTS

DESCRIPTION & MANUFACTURER	MODEL NO.	SERIAL NO.	DATE OF CALIBRATION	DUE DATE OF CALIBRATION
* ROHDE & SCHWARZ Spectrum Analyzer	FSP40	100039	Feb. 23, 2011	Feb. 22, 2012
* Mini-Circuits Power Splitter	ZN2PD-9G	NA	May 25, 2011	May 24, 2012
* Hewlett Packard RF cable	8120-6192	274388	Oct. 22, 2011	Oct. 21, 2012
* JFW 20dB attenuation	50HF-020-SMA	NA	NA	NA
* Suhner RF cable	Sucoflex104	274403/4	Aug. 20, 2011	Aug. 19, 2012

NOTE: 1. The calibration interval of the above test instruments is 12 months. And the calibrations are traceable to NML/ROC and NIST/USA.

2. "*" = These equipments are used for the final measurement.

4.5.3 TEST SETUP

Same as Item 4.1.4 (Conducted Power Setup)

4.5.4 TEST PROCEDURES

- a. The EUT was set up for the maximum peak power with LTE link data modulation. The power was measured with R&S Spectrum Analyzer. All measurements were done at 2 channels (low and high operational frequency range.).
- b. The band edge measurement used the power splitter via EUT RF power connector between simulation base station and spectrum analyzer.
- c. The center frequency of spectrum is the band edge frequency and span is 1 MHz. RB of the spectrum is 100kHz and VB of the spectrum is 300kHz.
- d. Record the max trace plot into the test report.

4.5.5 EUT OPERATING CONDITION

- a. The EUT makes a call to the communication simulator.
- b. The communication simulator station system controlled an EUT to export maximum output power under transmission mode and specific channel frequency.

4.5.6 TEST RESULTS

LTE Band 17

CHANNEL BANDWIDTH: 5MHz / QPSK / 1 RB

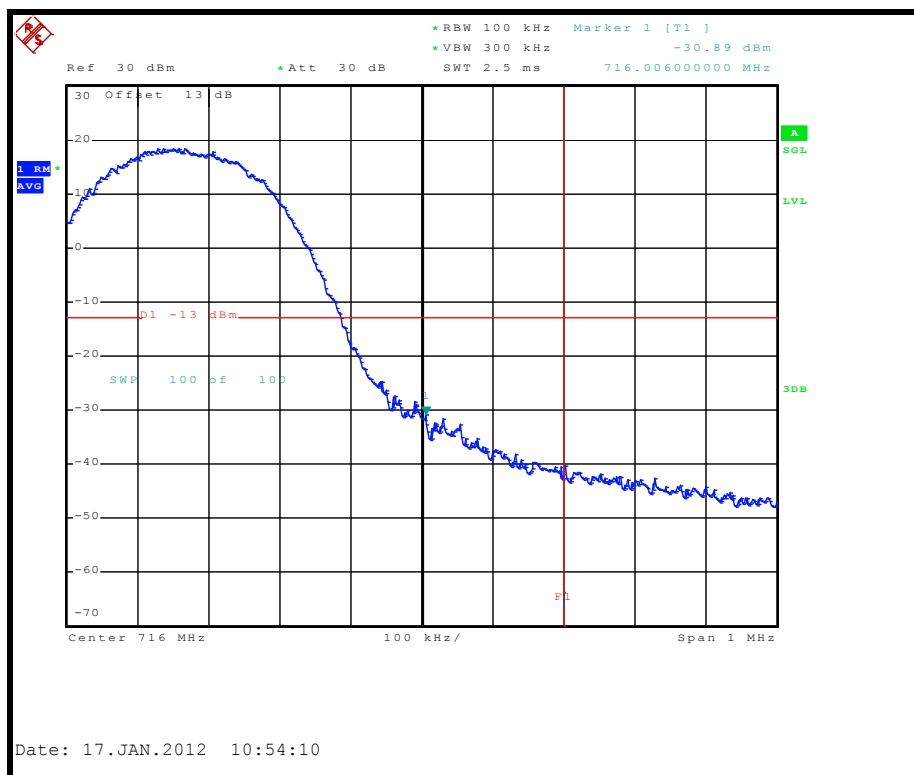
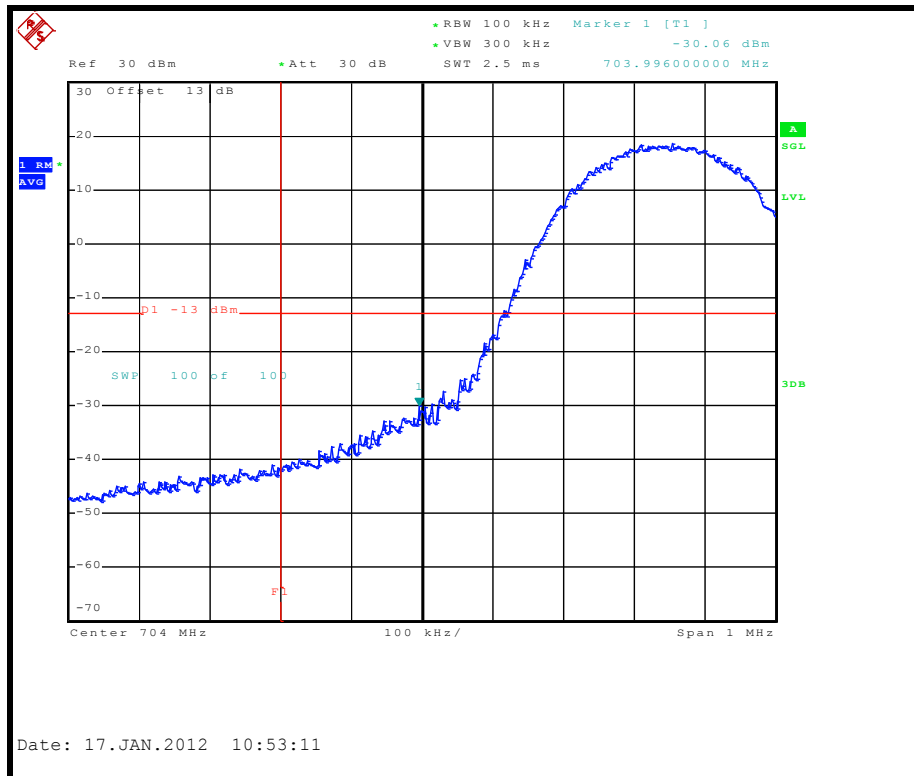



A D T

LTE Band 17

CHANNEL BANDWIDTH: 5MHz / QPSK / 25 RB

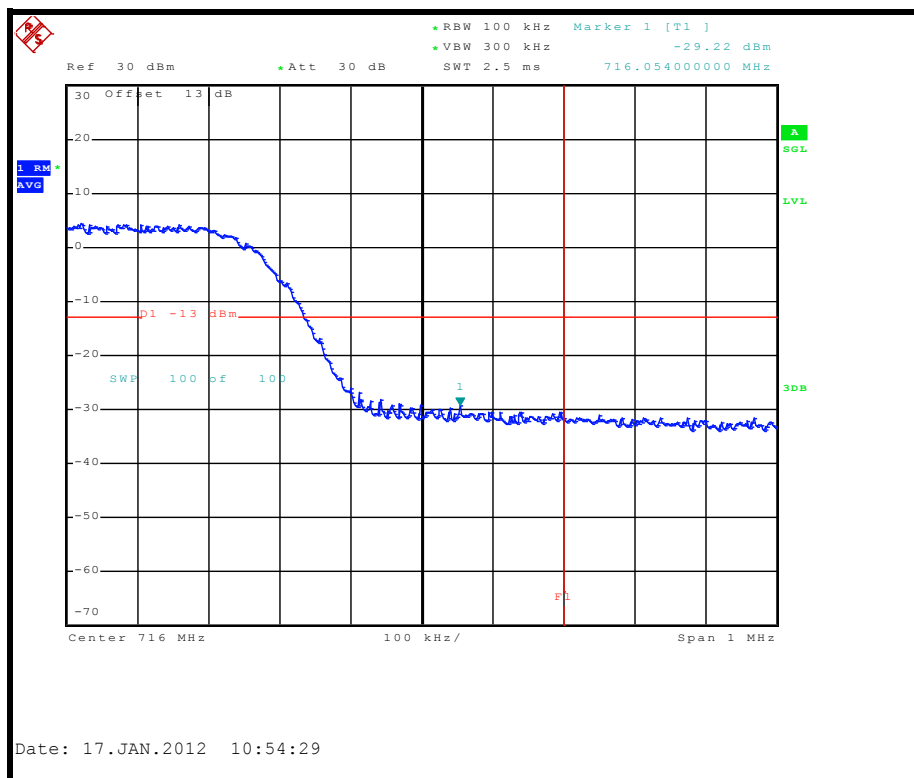
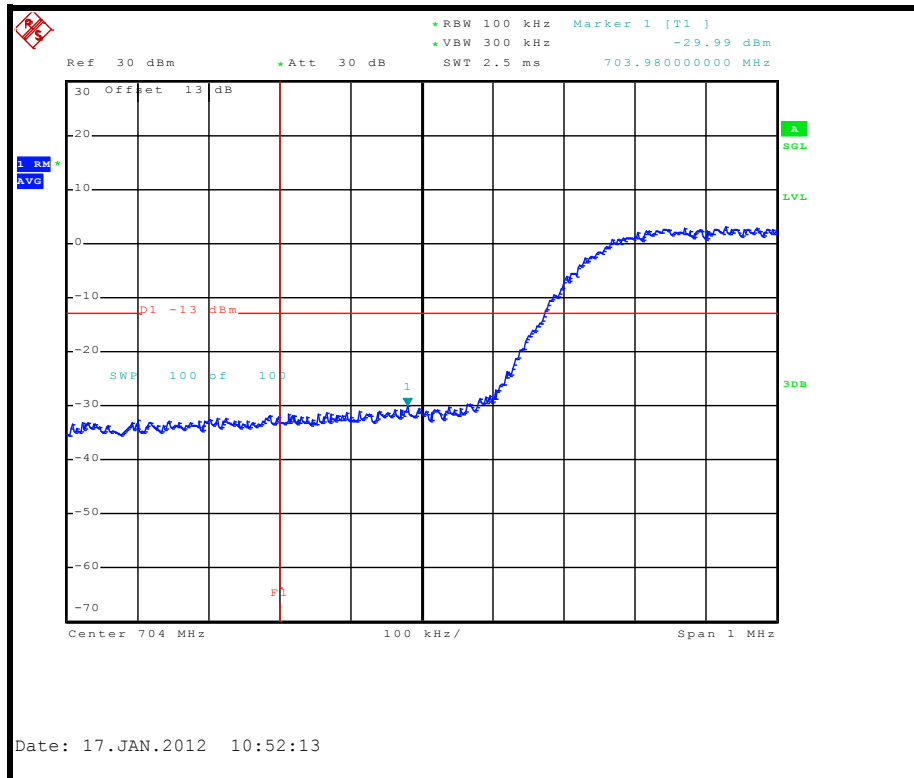



A D T

LTE Band 17

CHANNEL BANDWIDTH: 10MHz / QPSK / 1 RB

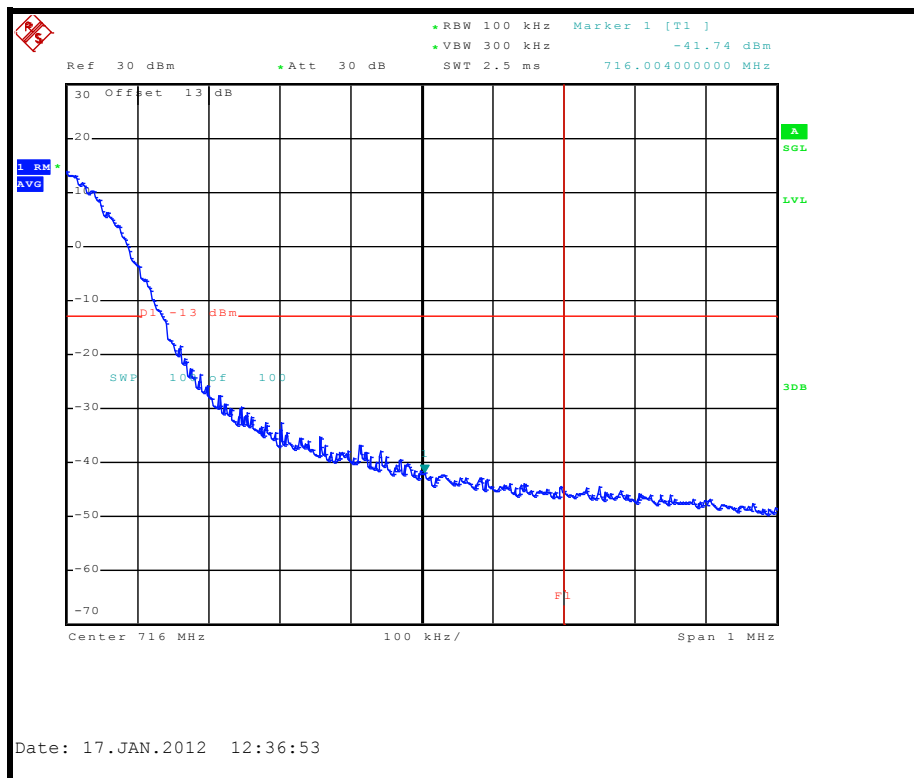
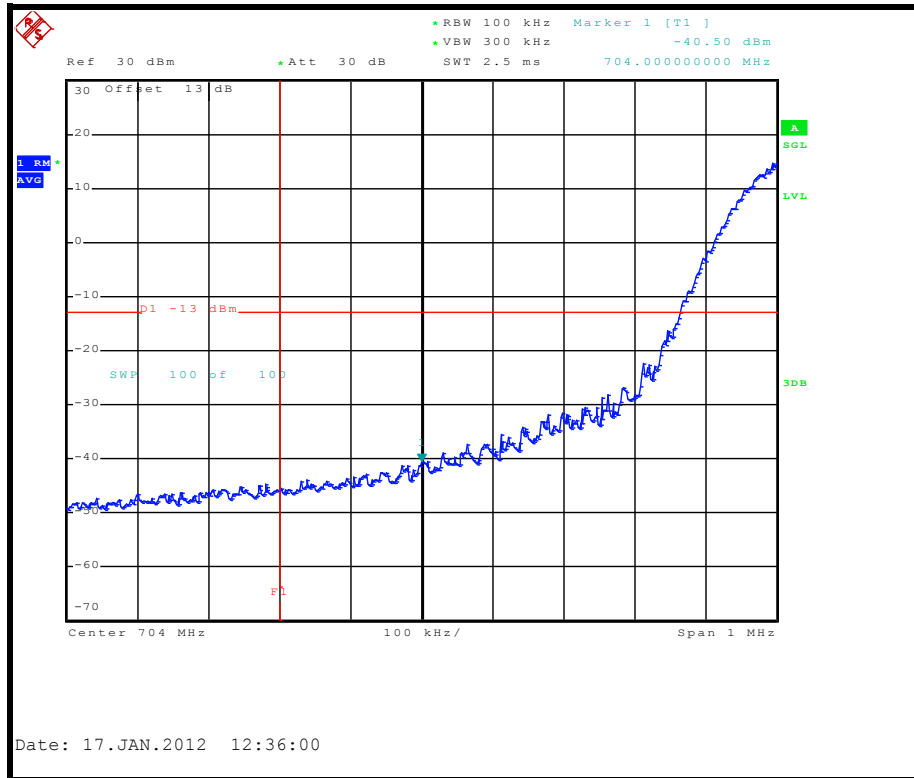



A D T

LTE Band 17

CHANNEL BANDWIDTH: 10MHz / QPSK / 50 RB

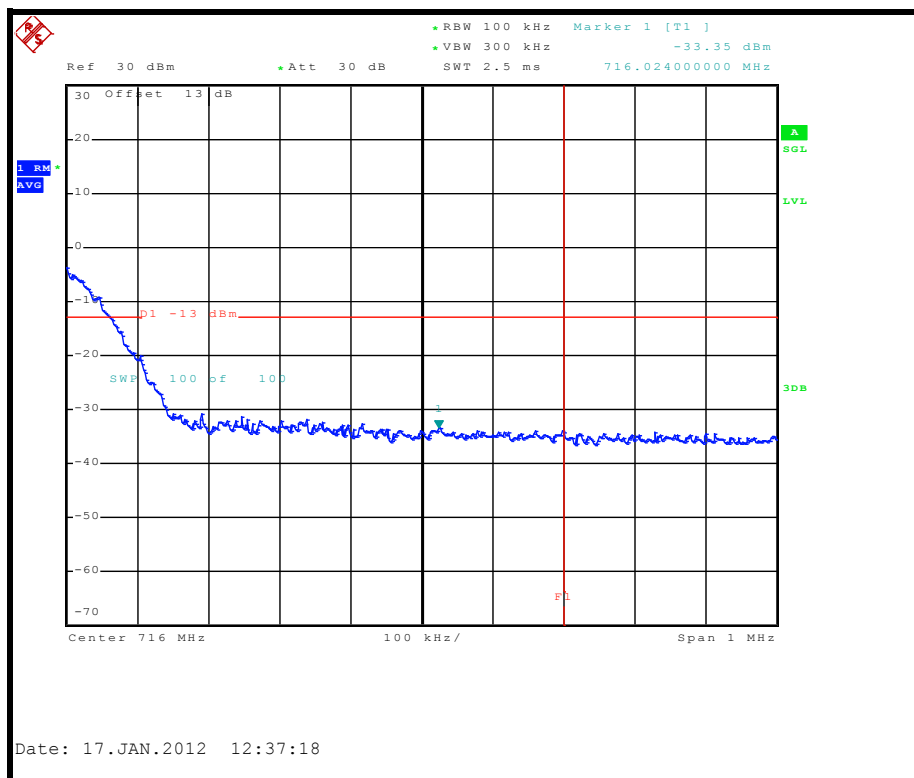
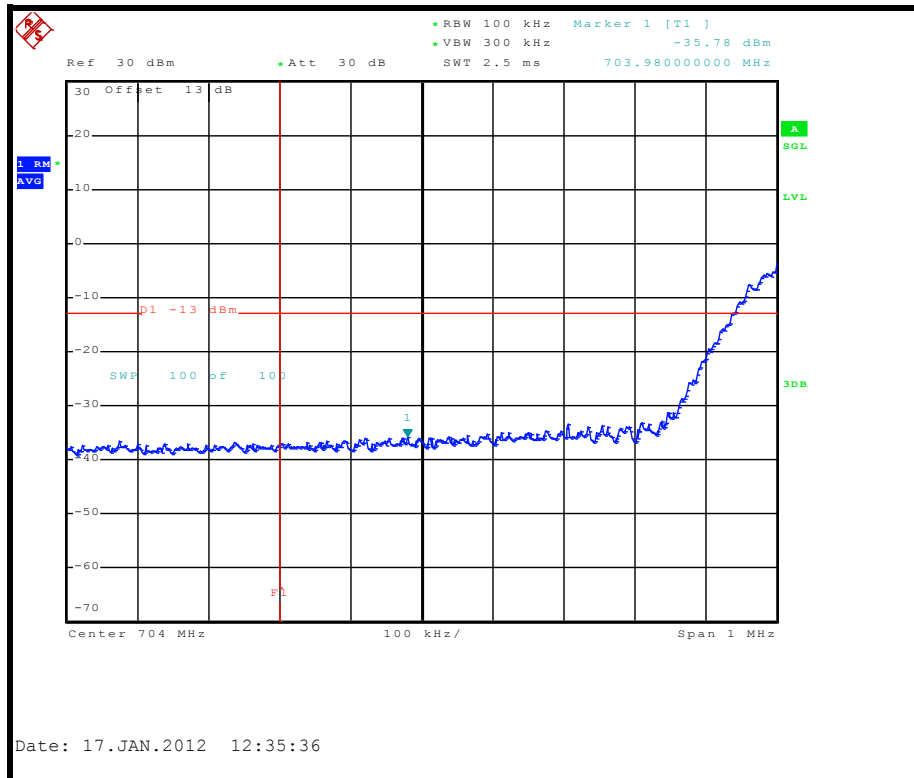

LTE Band 4

CHANNEL BANDWIDTH: 5MHz / QPSK / 1 RB

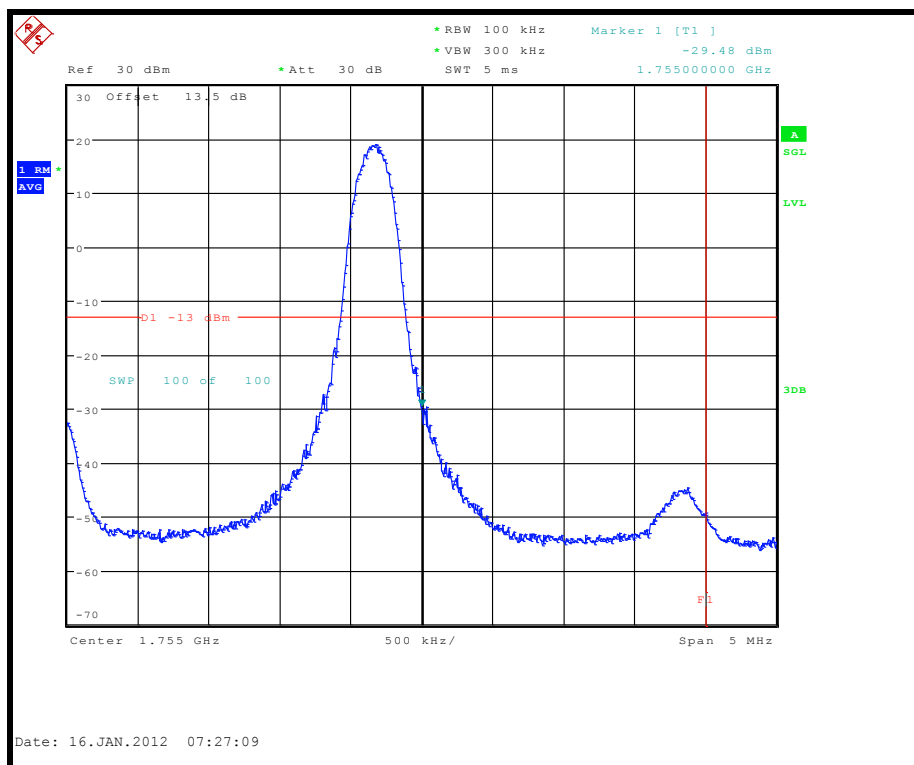
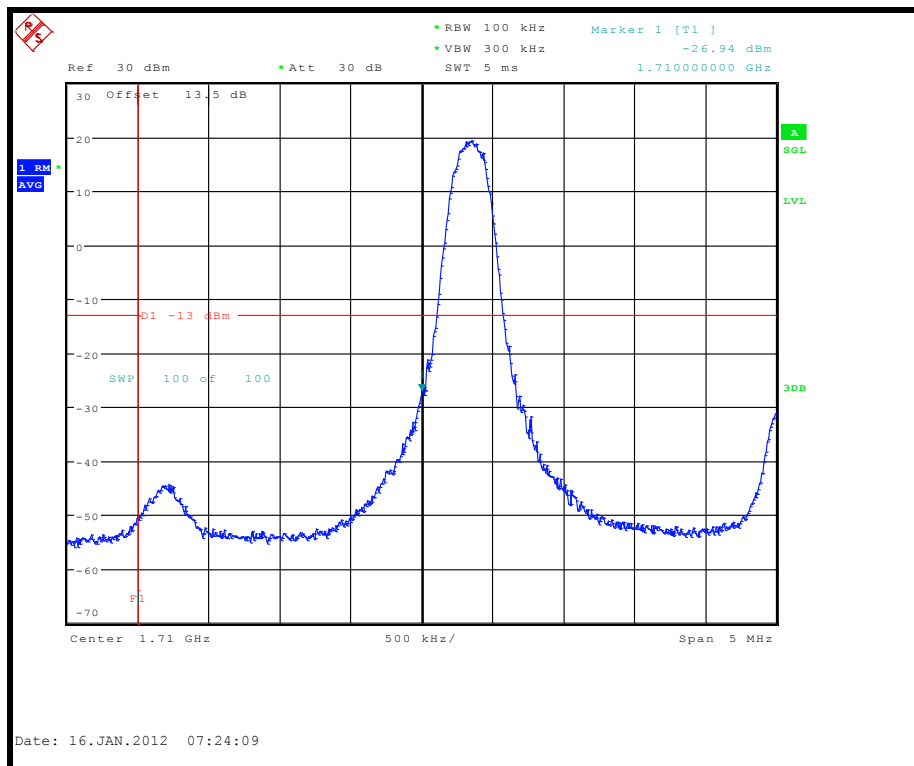

LTE Band 4

CHANNEL BANDWIDTH: 5MHz / QPSK / 25 RB

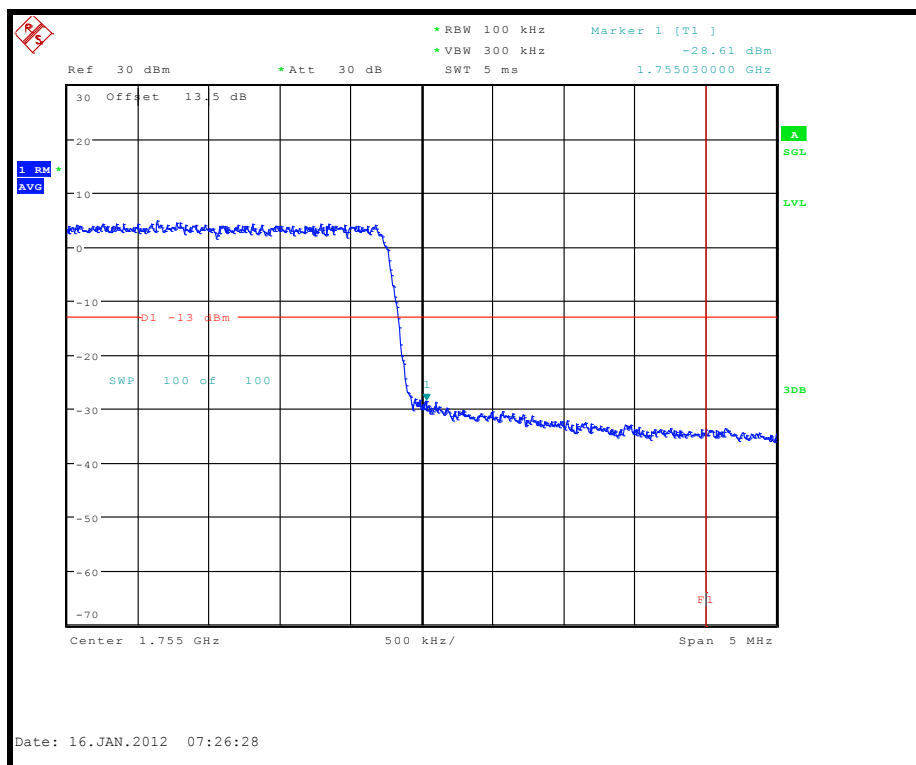
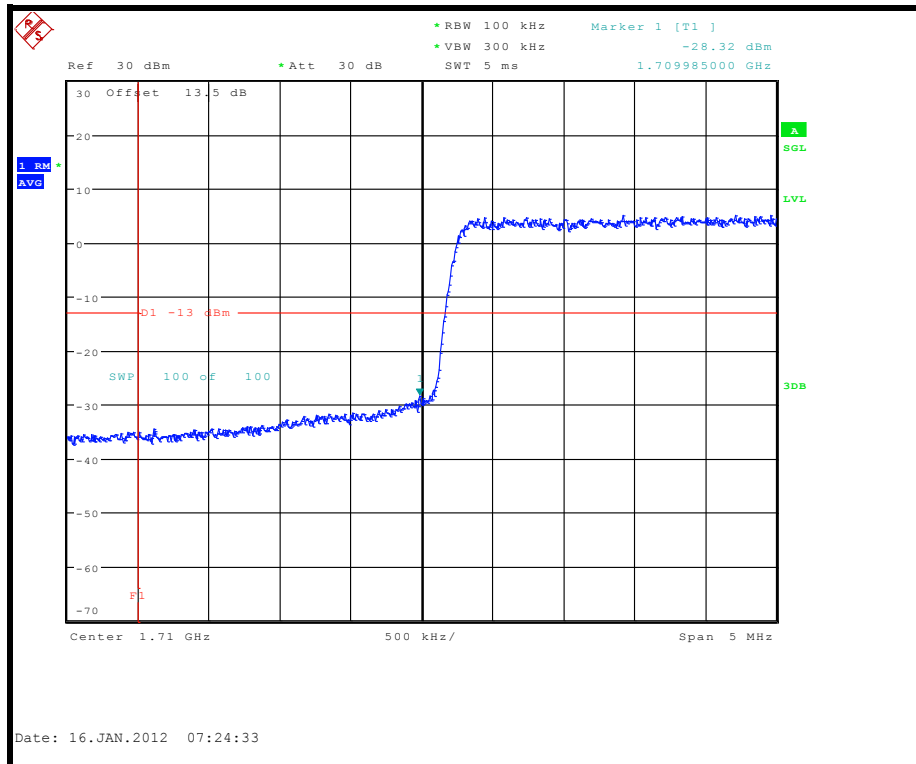



A D T

LTE Band 4

CHANNEL BANDWIDTH: 10MHz / QPSK / 1 RB

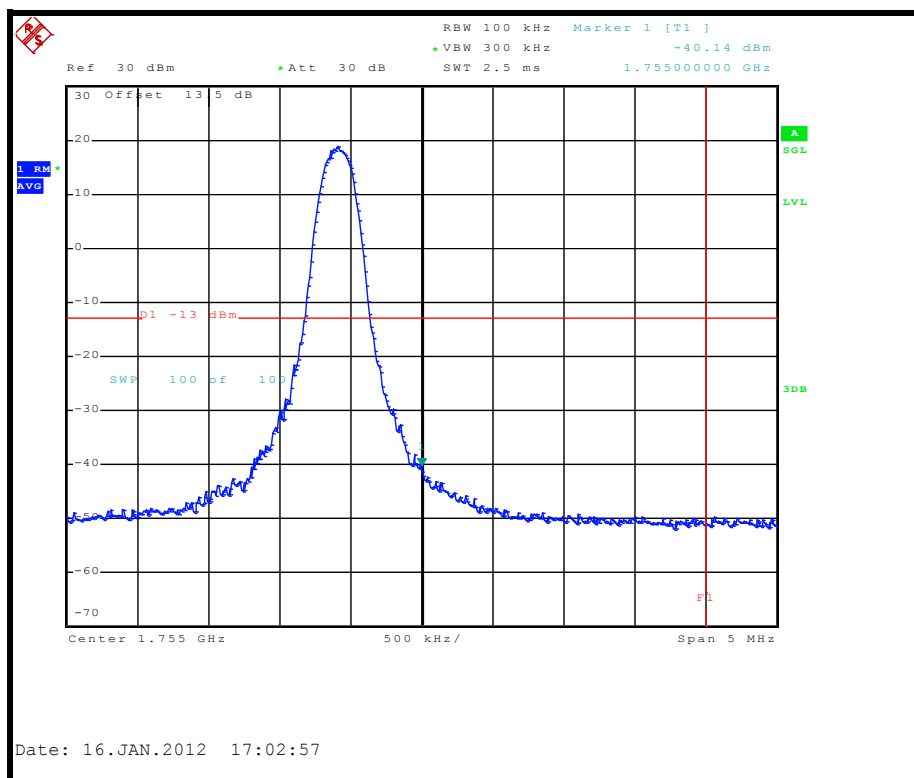
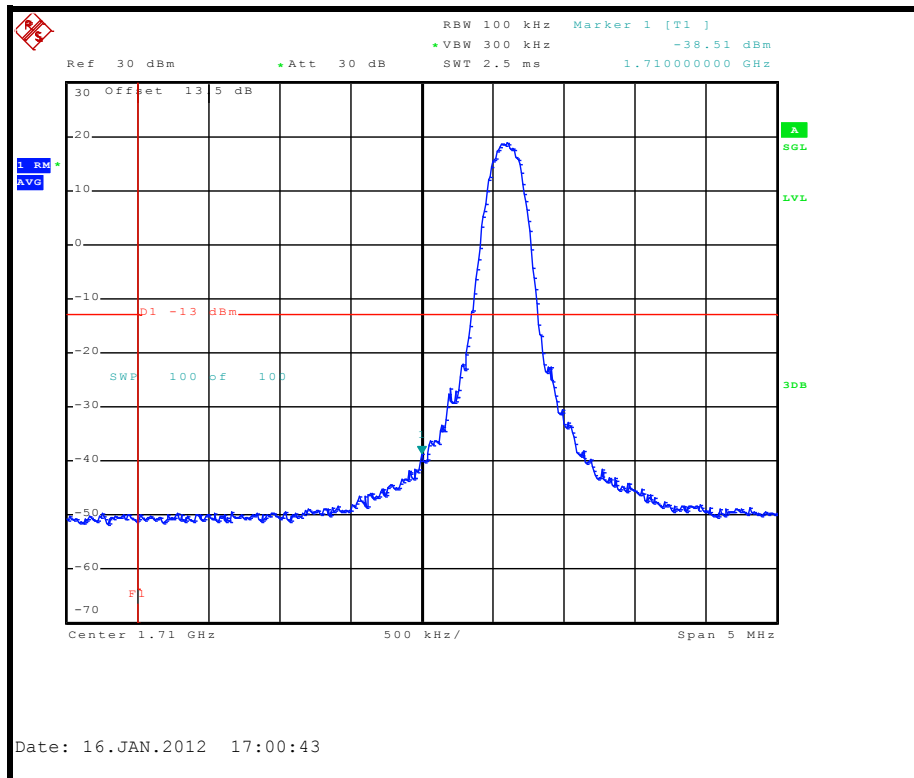



A D T

LTE Band 4

CHANNEL BANDWIDTH: 10MHz / QPSK / 50 RB

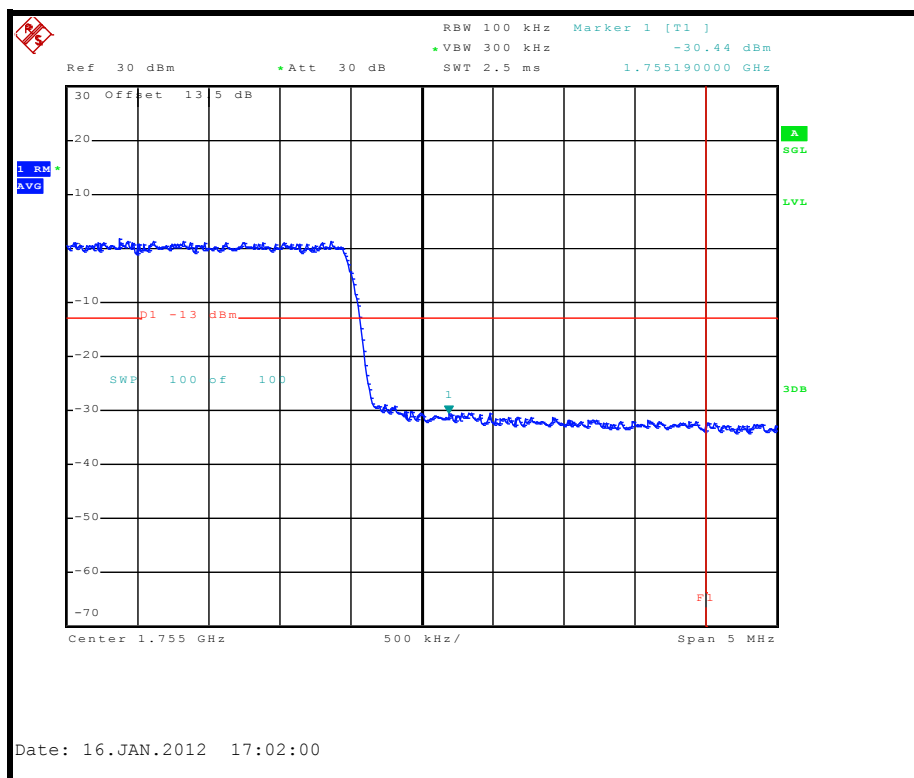
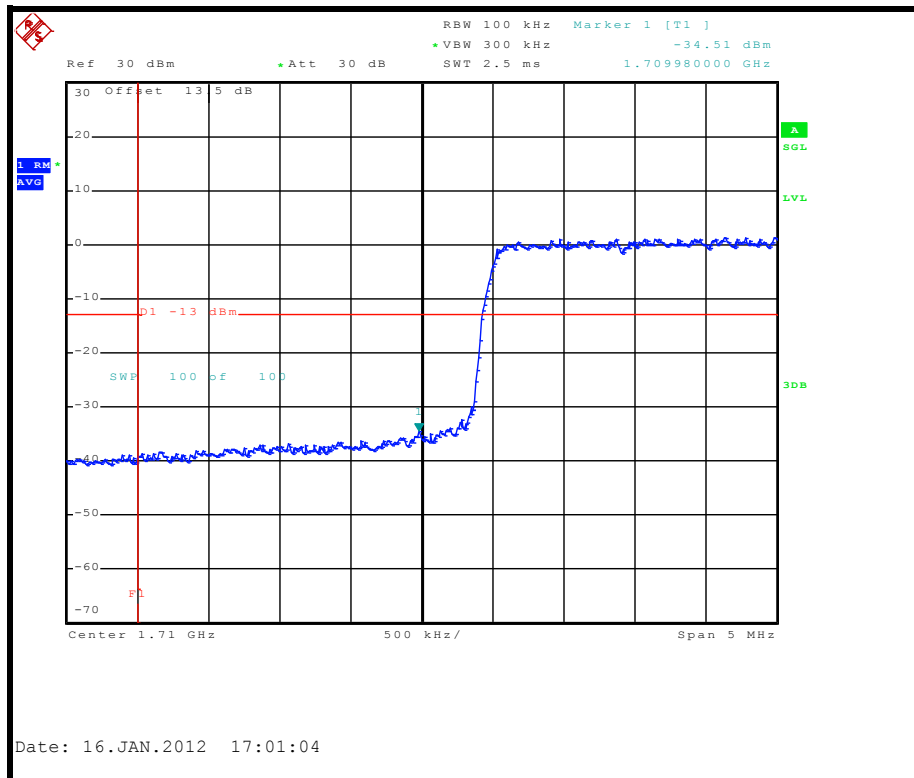

4.6 CONDUCTED SPURIOUS EMISSIONS

4.6.1 LIMITS OF CONDUCTED SPURIOUS EMISSIONS MEASUREMENT

The power of any emission outside a licensee's frequency block shall be attenuated below the transmitter power (P) by at least $43 + 10 \log_{10}(P)$ dB. The limit of emission equal to -13dBm

4.6.2 TEST INSTRUMENTS

DESCRIPTION & MANUFACTURER	MODEL NO.	SERIAL NO.	DATE OF CALIBRATION	DUE DATE OF CALIBRATION
* ROHDE & SCHWARZ Spectrum Analyzer	FSP40	100039	Jan. 11, 2011	Jan. 10, 2012
* Wainwright Instruments Band Reject Filter	WRCG 1710/1785-1690/18 05-60/12SS	SN1	Oct. 28, 2011	Oct. 27, 2012
* Wainwright Instruments High Pass Filter	WHK3.1/18G-10SS	SN3	Jun. 14, 2011	Jun. 13, 2012
* Mini-Circuits Power Splitter	ZAPD-4	NA	Mar. 24, 2011	Mar. 23, 2012
* Hewlett Packard RF cable	8120-6192	274388	Oct. 22, 2011	Oct. 21, 2012
* JFW 20dB attenuation	50HF-020-SMA	NA	NA	NA
* Suhner RF cable	Sucoflex104	274403/4	Aug. 20, 2011	Aug. 19, 2012

- NOTE:**
1. The calibration interval of the above test instruments is 12 months. And the calibrations are traceable to NML/ROC and NIST/USA.
 2. "*" = These equipments are used for the final measurement.

4.6.3 TEST PROCEDURE

- a. The EUT was set up for the maximum peak power with LTE link data modulation. The power was measured with R&S Spectrum Analyzer. All measurements were done at 3 channels (low, middle and high operational frequency range.).
- b. The conducted spurious emission used the power splitter via EUT RF power connector between simulation base station and spectrum analyzer.
- c. When the spectrum scanned from 30MHz to 3GHz, it shall be connected to the band reject filter attenuated the carried frequency. The spectrum set RB=1MHz, VB=3MHz.
- d. When the spectrum scanned from 3GHz to 20GHz, it shall be connected to the high pass filter attenuated the carried frequency. The spectrum set RB=1MHz, VB=3MHz.

4.6.4 TEST SETUP

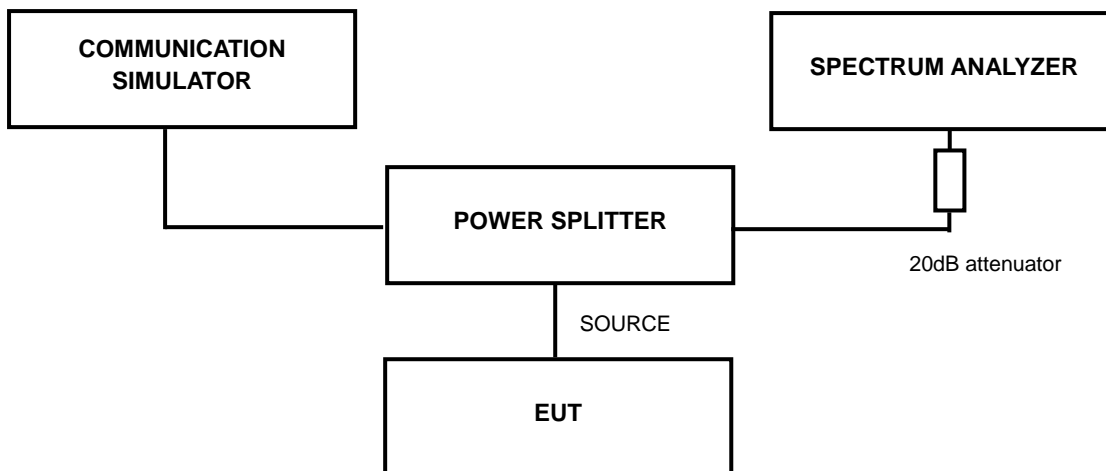

4.6.5 EUT OPERATING CONDITIONS

- a. The EUT makes a phone call to the communication simulator.
- b. The communication simulator station system controlled a EUT to export maximum output power under transmission mode and specific channel frequency.

4.6.6 TEST RESULTS

LTE Band 17

CHANNEL BANDWIDTH: 5MHz / QPSK / 0 RB Offset

CH 706.5: 30MHz ~ 1GHz

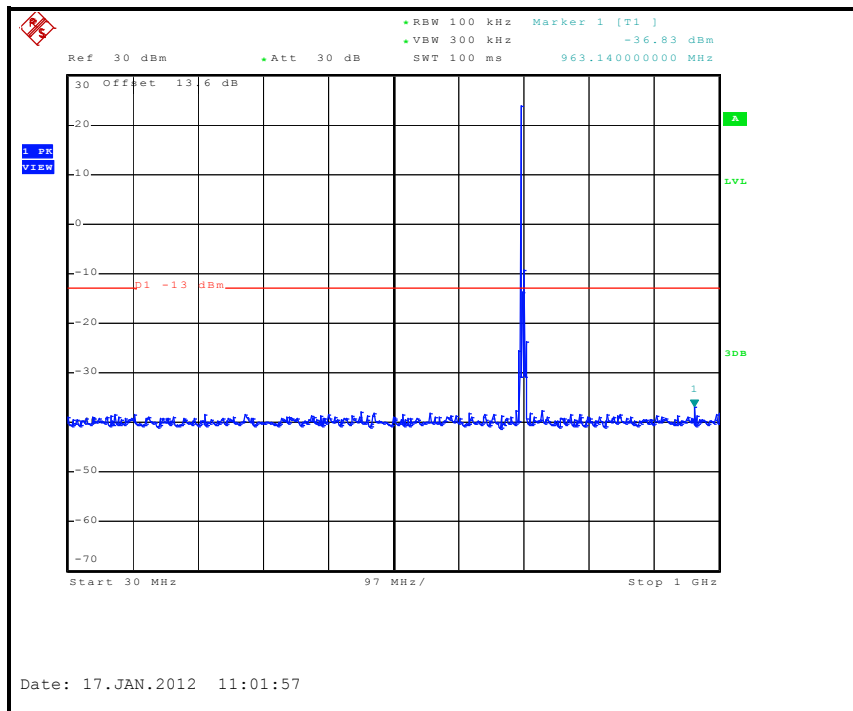

1GHz ~ 3GHz

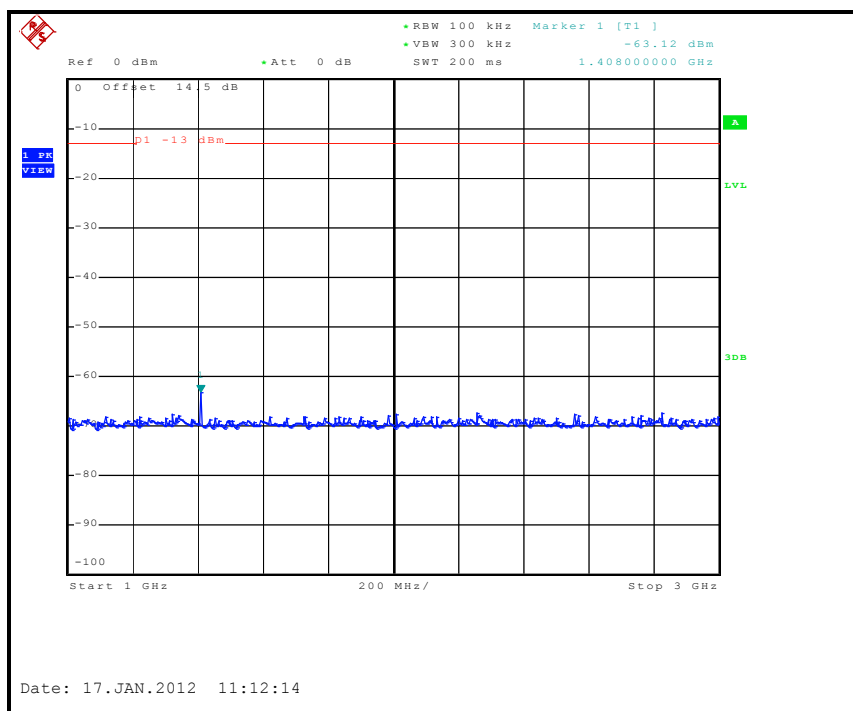



A D T

3GHz ~ 8GHz

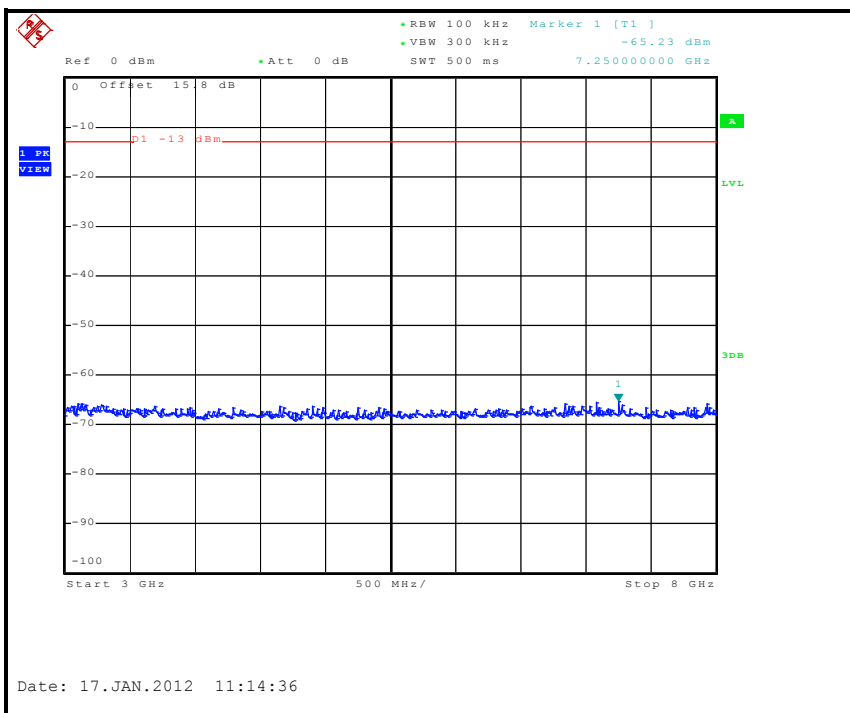



A D T

LTE Band 17

CHANNEL BANDWIDTH: 5MHz / QPSK / 24 RB Offset
CH 706.5: 30MHz ~ 1GHz

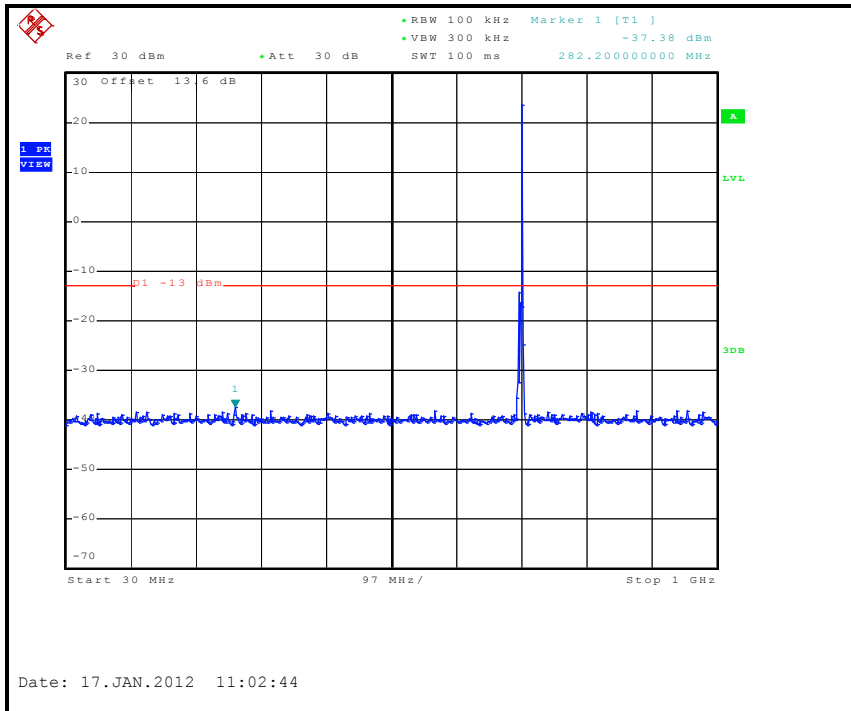

1GHz ~ 3GHz

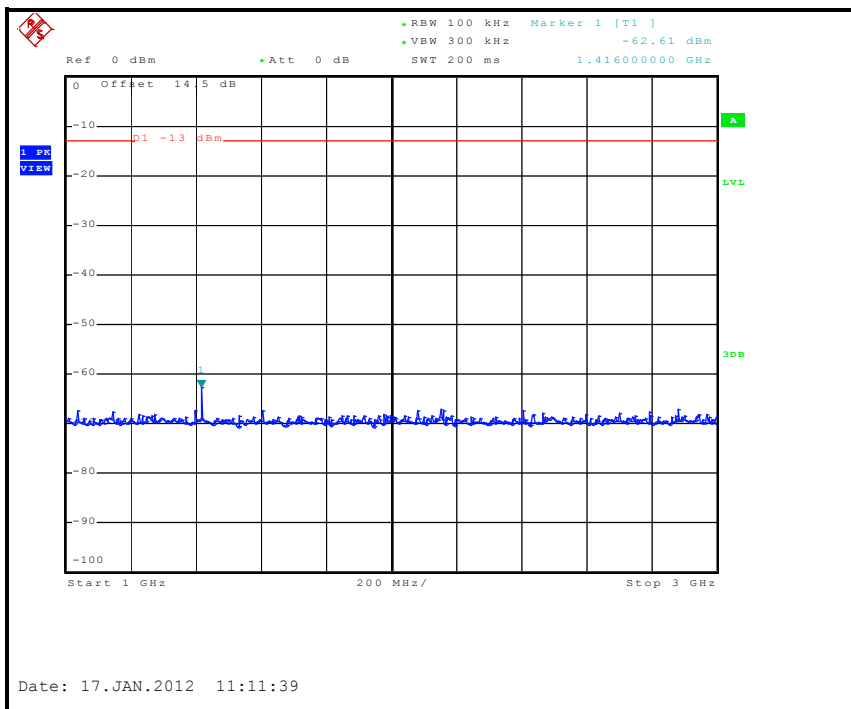



A D T

3GHz ~ 8GHz

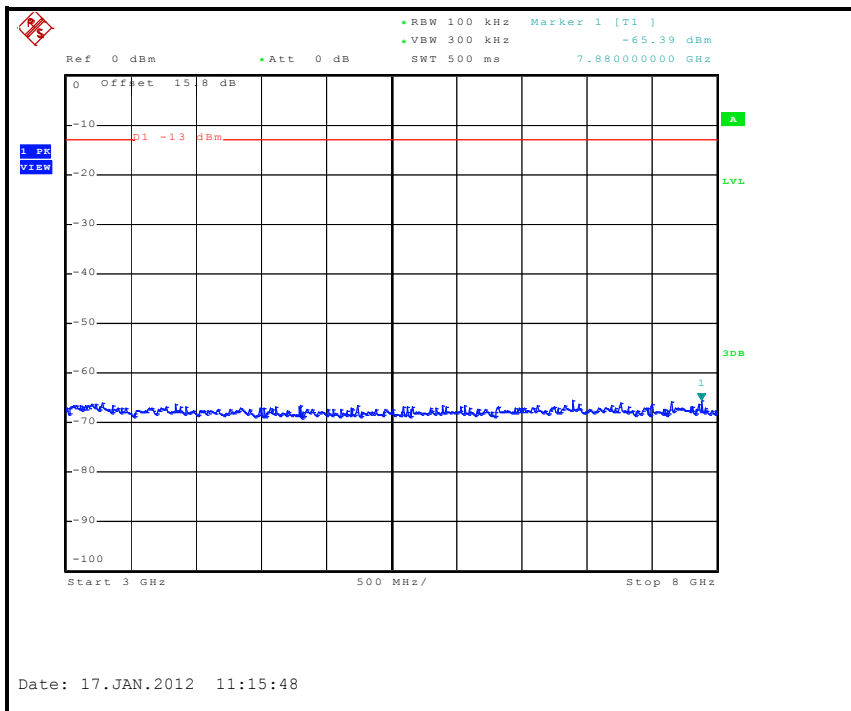

Date: 17.JAN.2012 11:15:48



A D T

LTE Band 17

CHANNEL BANDWIDTH: 5MHz / QPSK / 0 RB Offset

CH 710: 30MHz ~ 1GHz

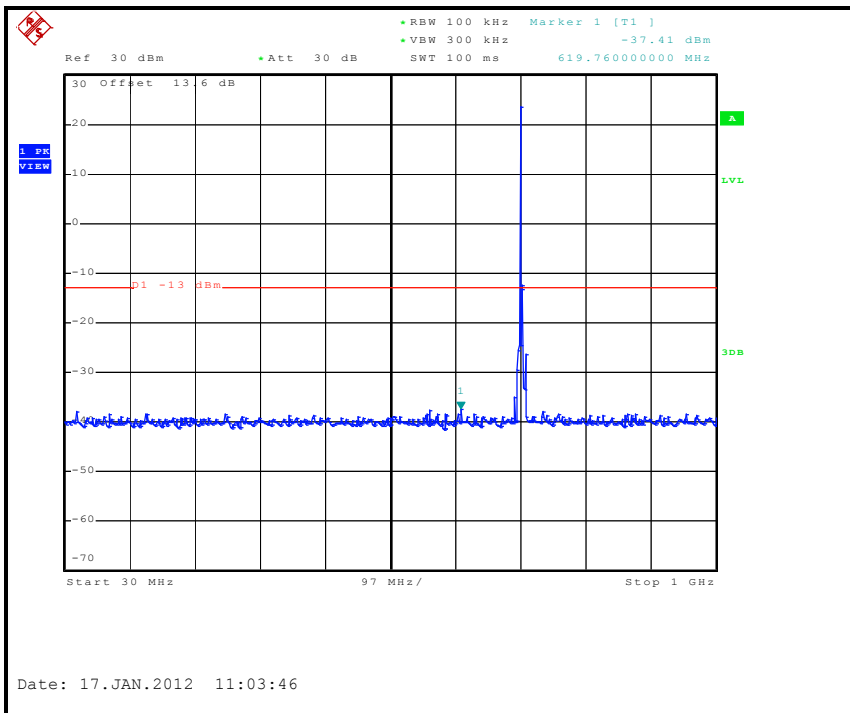

1GHz ~ 3GHz

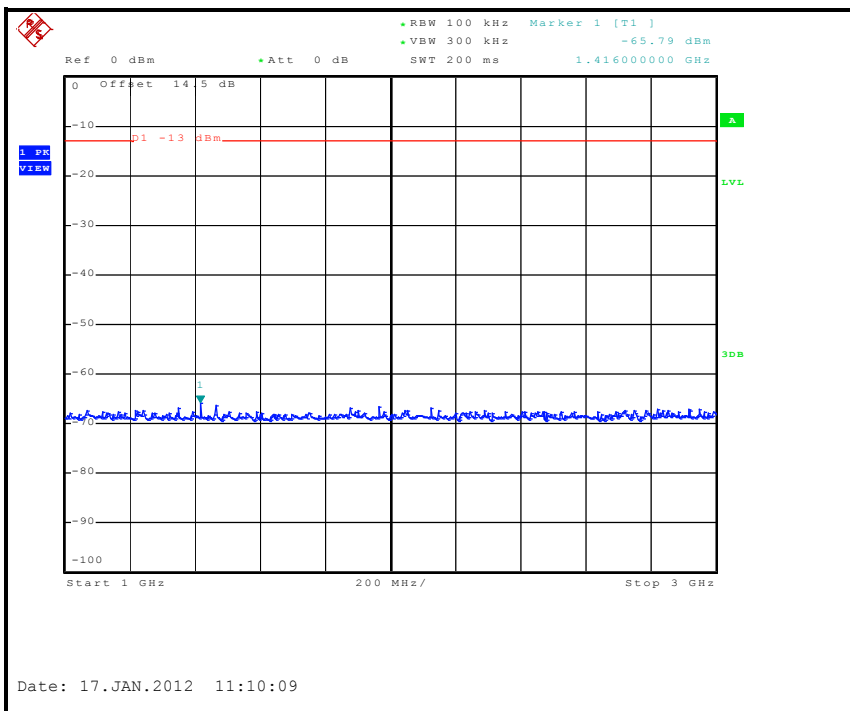



A D T

3GHz ~ 8GHz

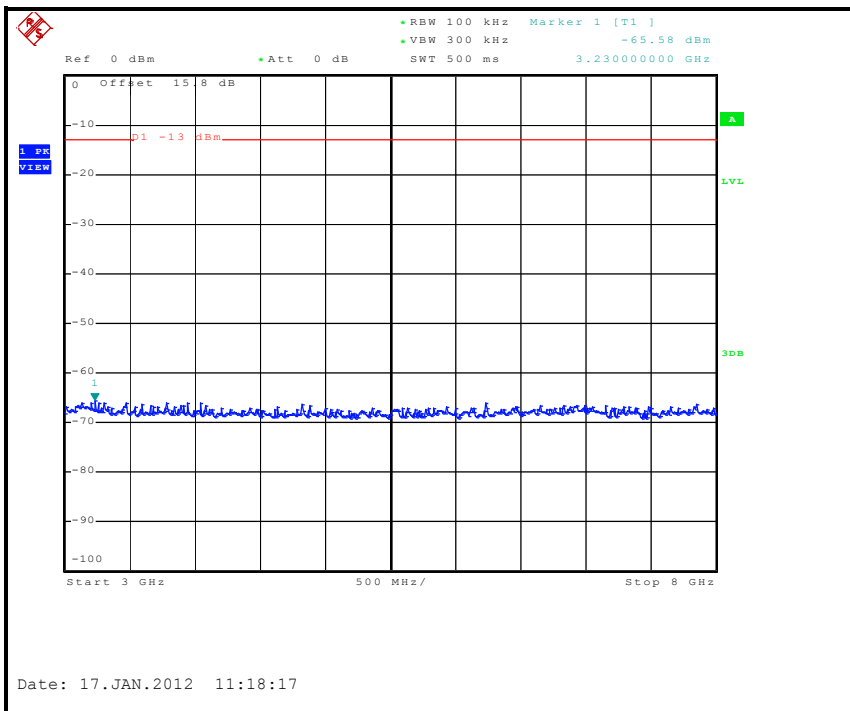

Date: 17.JAN.2012 11:18:17



A D T

LTE Band 17

CHANNEL BANDWIDTH: 5MHz / QPSK / 24 RB Offset

CH 710: 30MHz ~ 1GHz

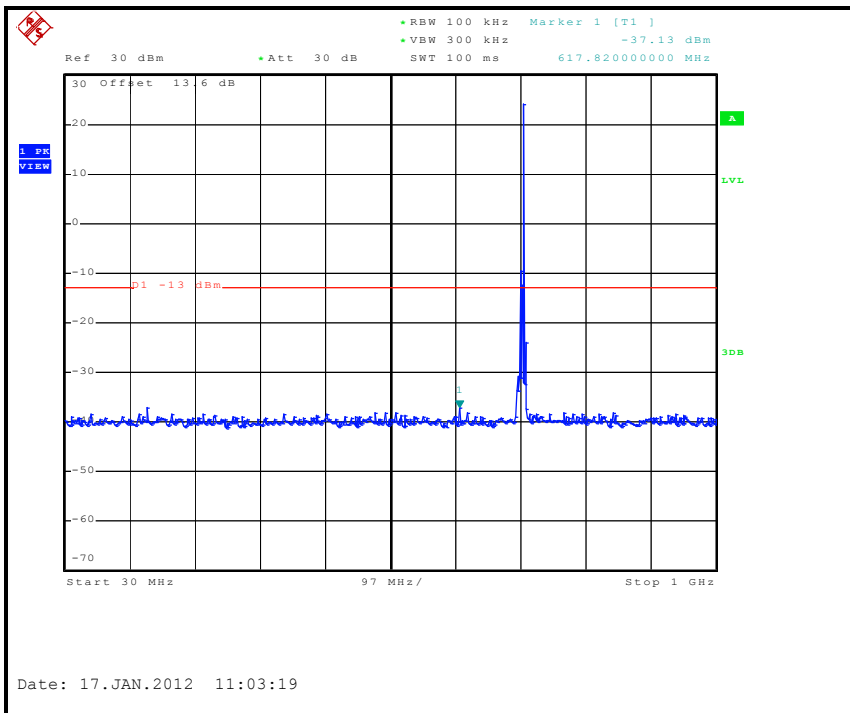

1GHz ~ 3GHz

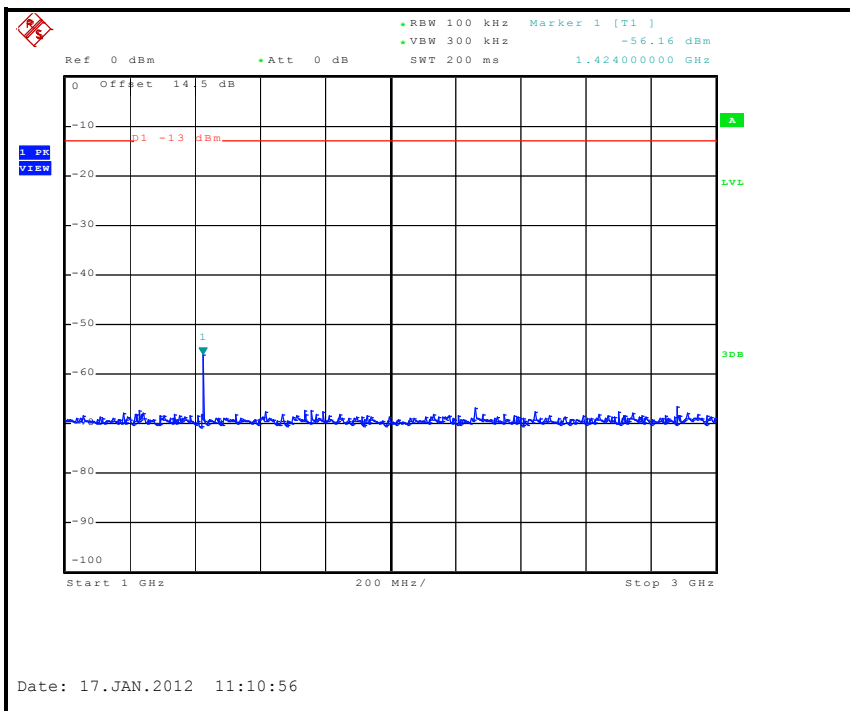



A D T

3GHz ~ 8GHz

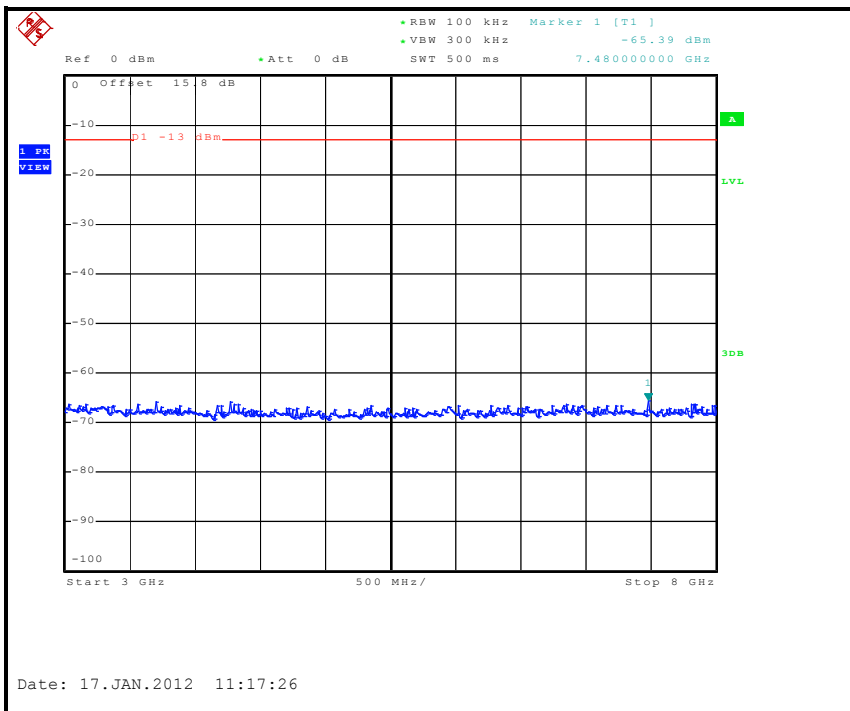

Date: 17.JAN.2012 11:17:26



A D T

LTE Band 17

CHANNEL BANDWIDTH: 5MHz / QPSK / 0 RB Offset
CH 713.5: 30MHz ~ 1GHz

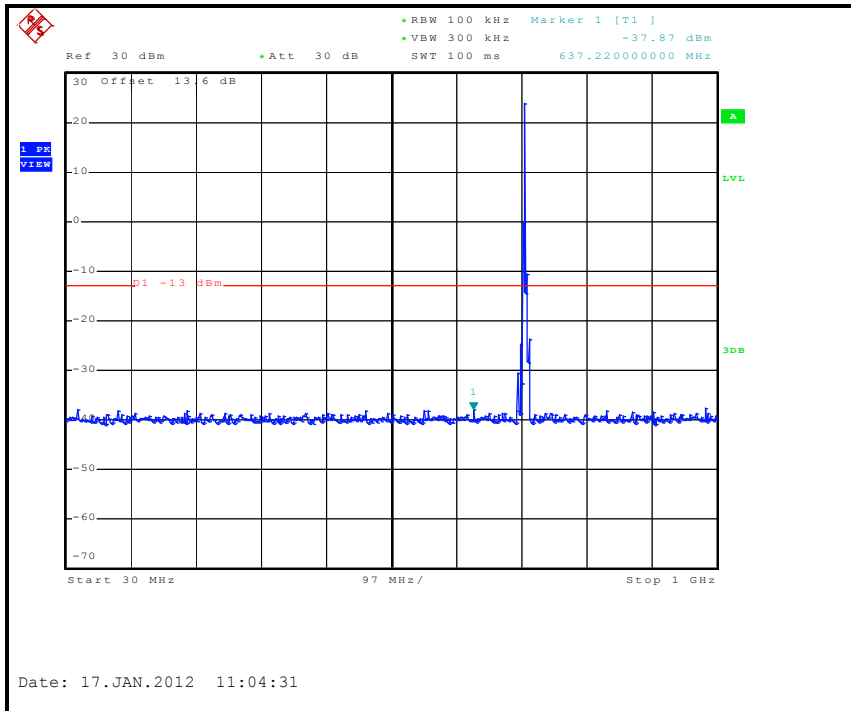

1GHz ~ 3GHz

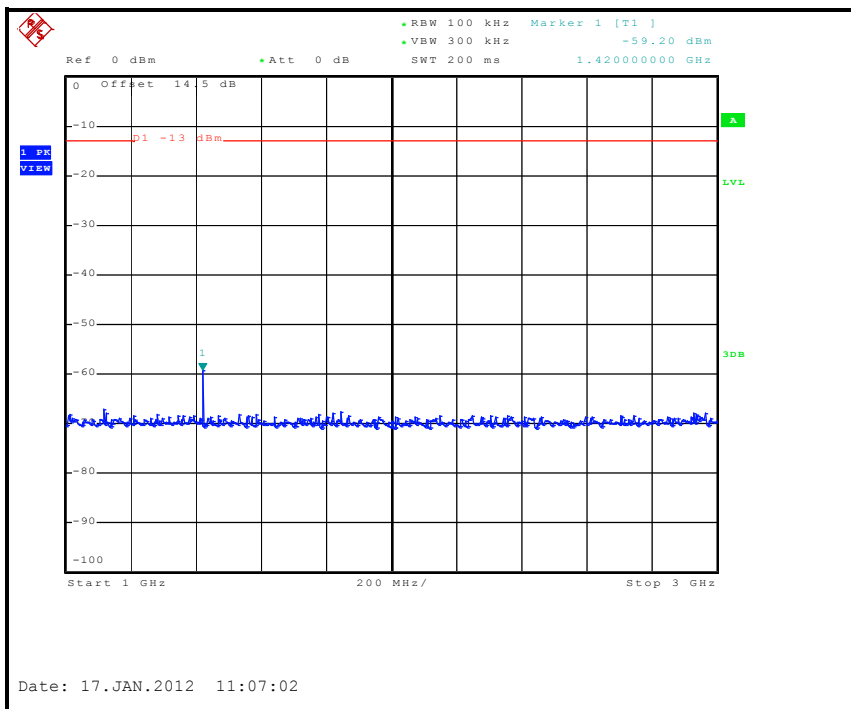



A D T

3GHz ~ 8GHz

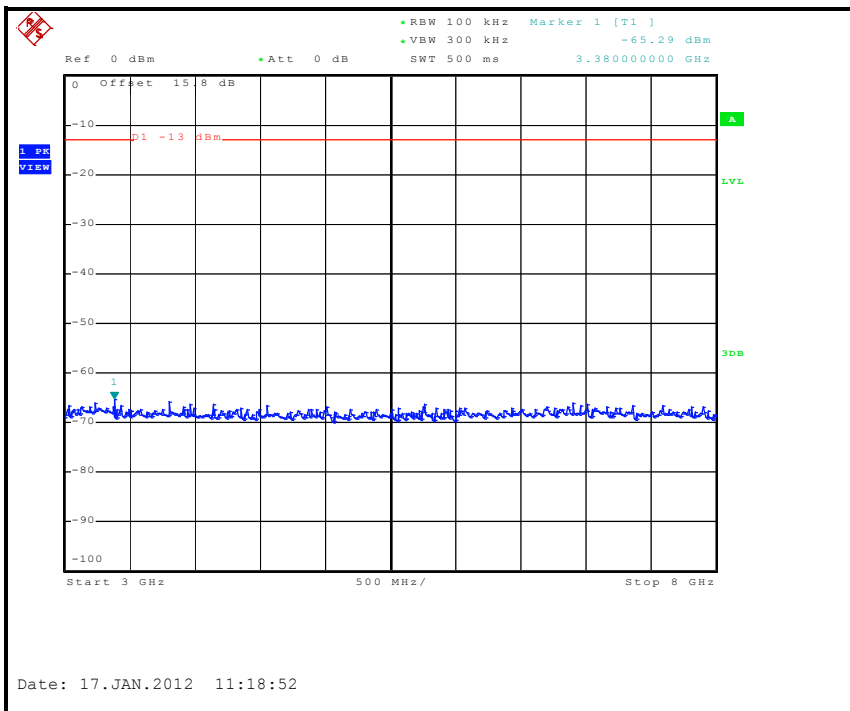

Date: 17.JAN.2012 11:18:52

LTE Band 17
CHANNEL BANDWIDTH: 5MHz / QPSK / 24 RB Offset
CH 713.5: 30MHz ~ 1GHz

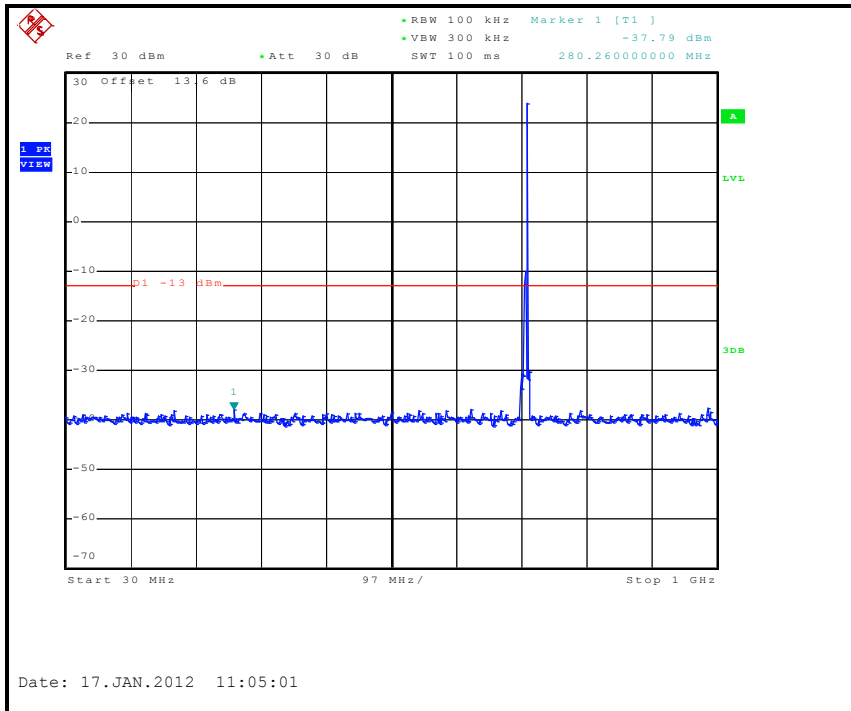

1GHz ~ 3GHz

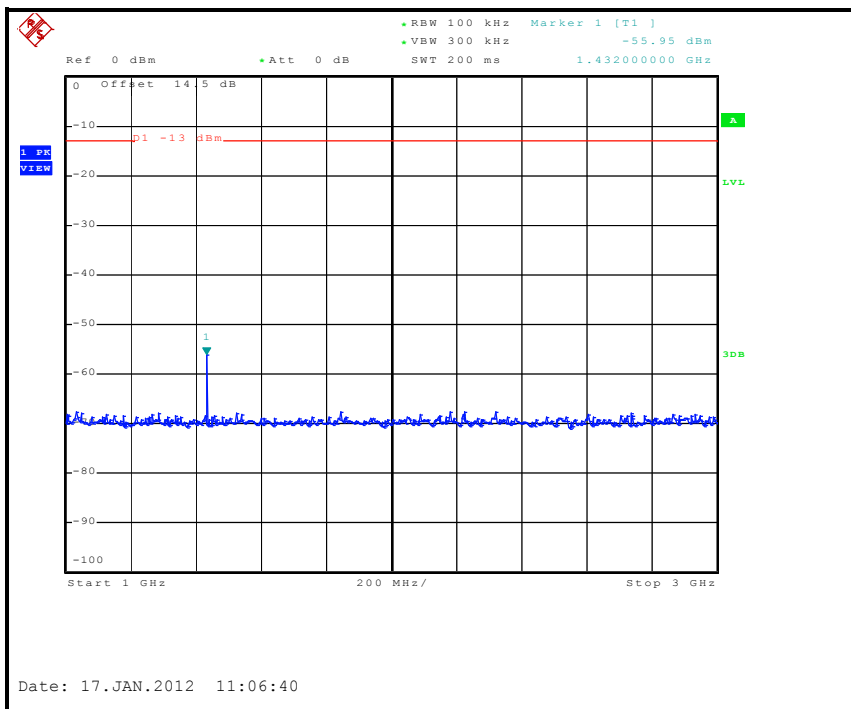



A D T

3GHz ~ 8GHz

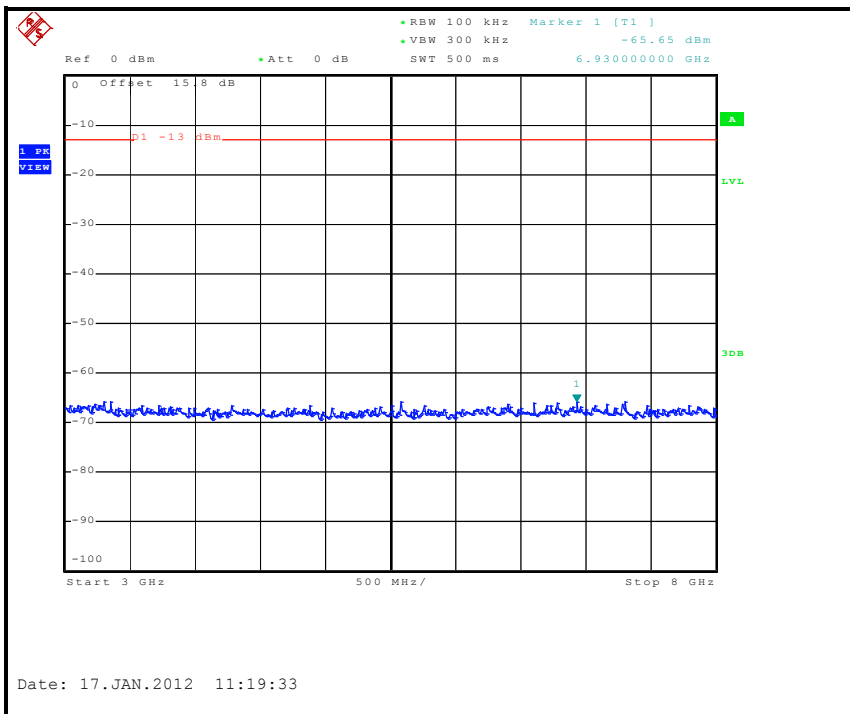



A D T

LTE Band 17

CHANNEL BANDWIDTH: 10MHz / QPSK / 0 RB Offset

CH 709: 30MHz ~ 1GHz

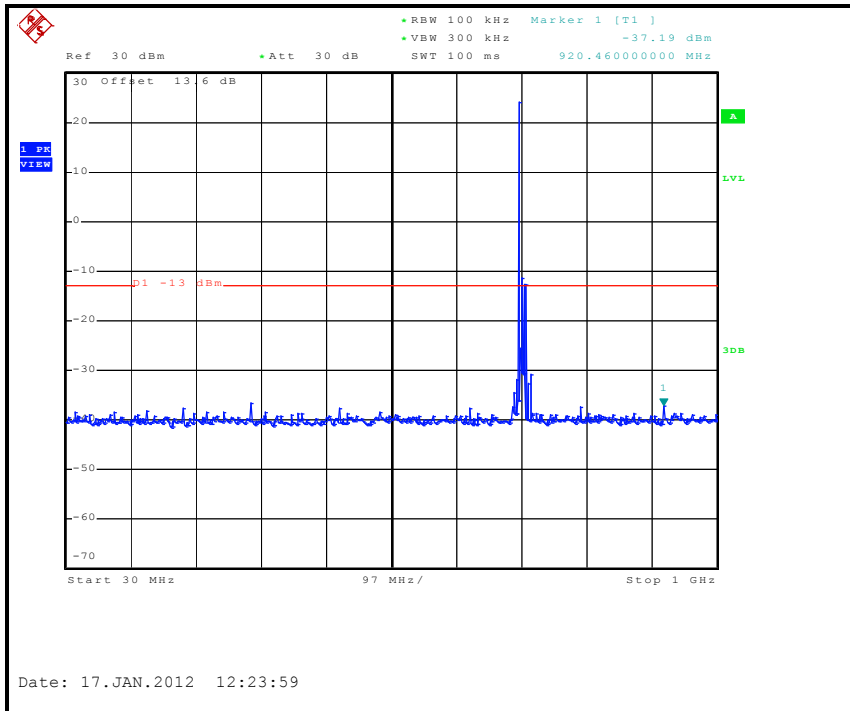

1GHz ~ 3GHz

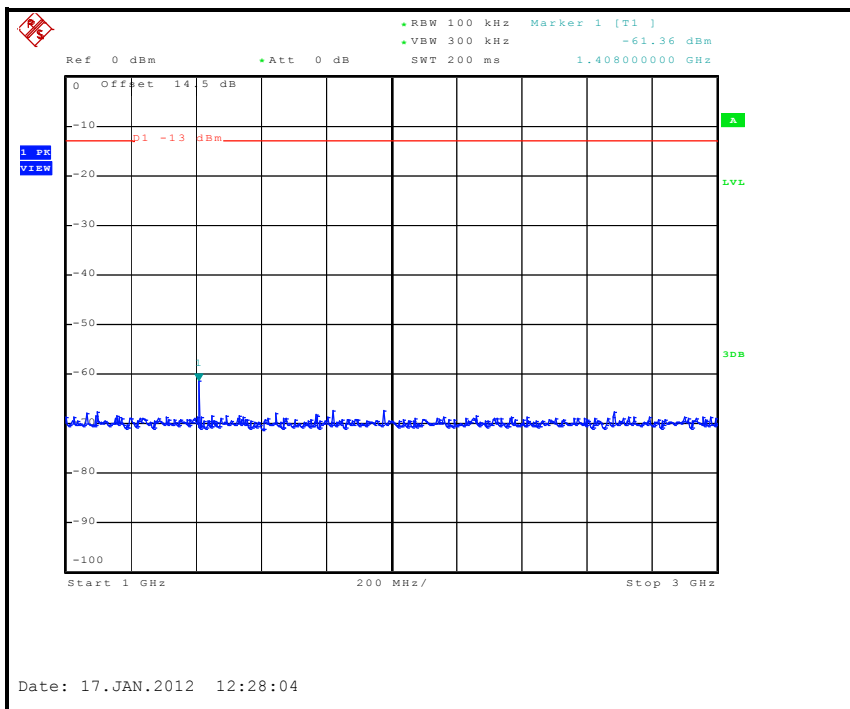



A D T

3GHz ~ 8GHz

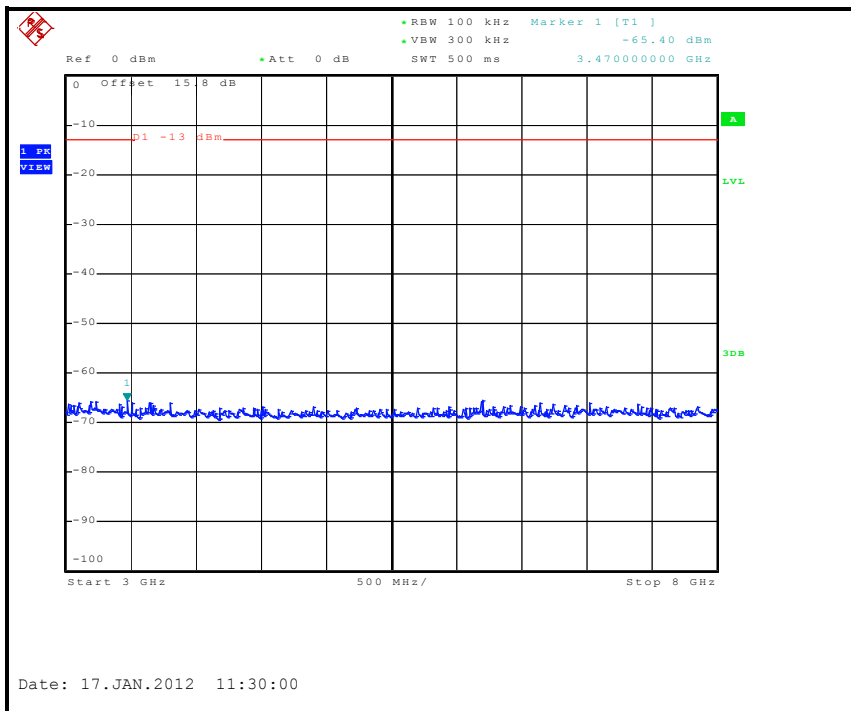



A D T

LTE Band 17

CHANNEL BANDWIDTH: 10MHz / QPSK / 49 RB Offset

CH 709: 30MHz ~ 1GHz

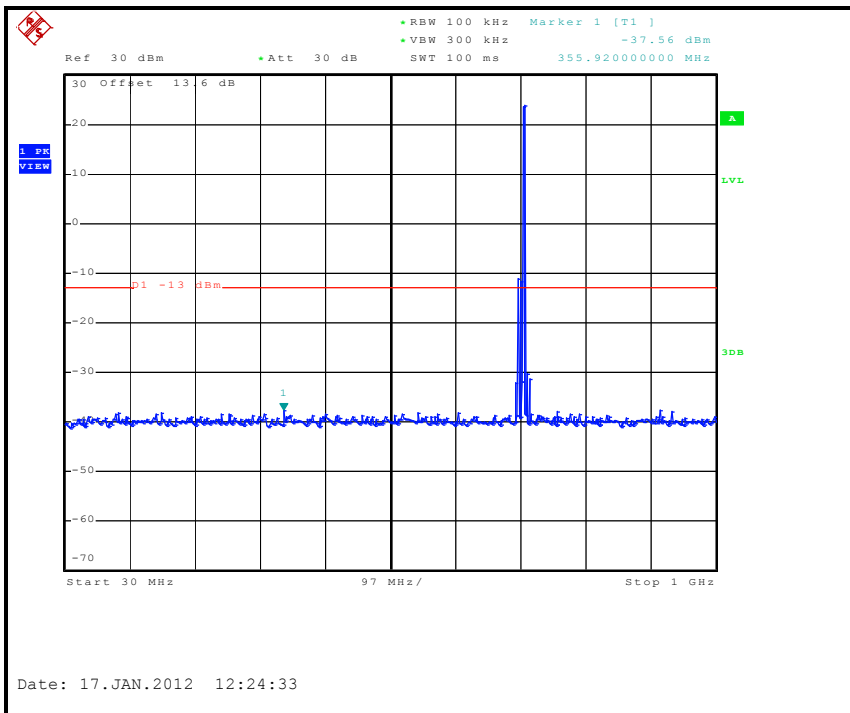

1GHz ~ 3GHz

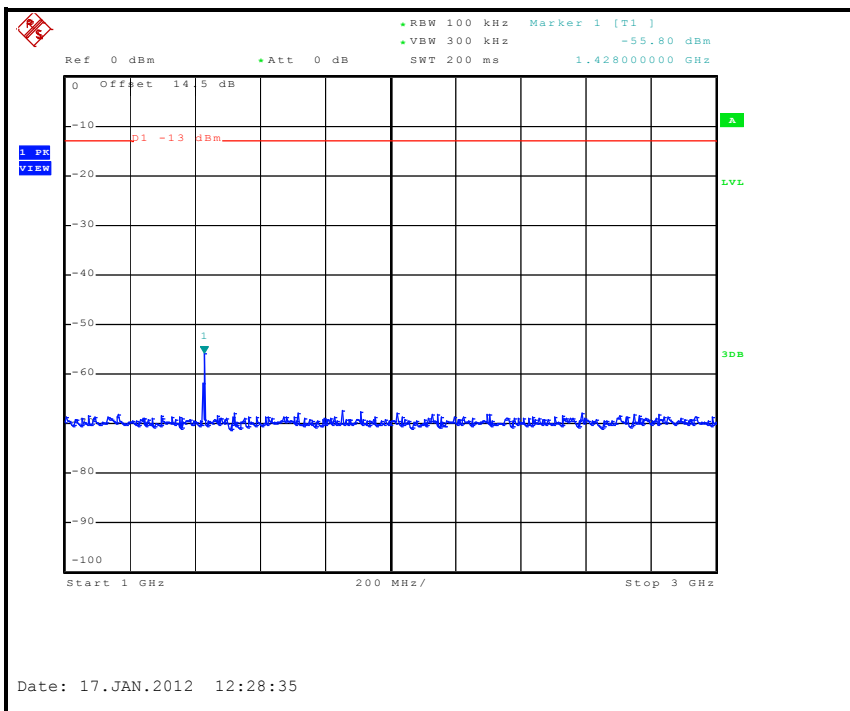



A D T

3GHz ~ 8GHz

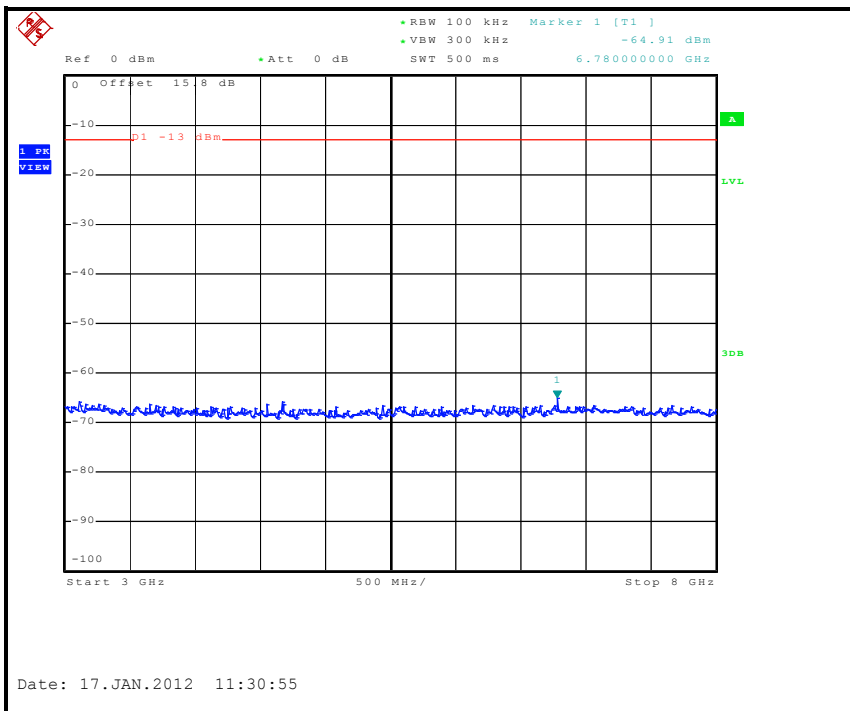

LTE Band 17
CHANNEL BANDWIDTH: 10MHz / QPSK / 0 RB Offset
CH 710: 30MHz ~ 1GHz

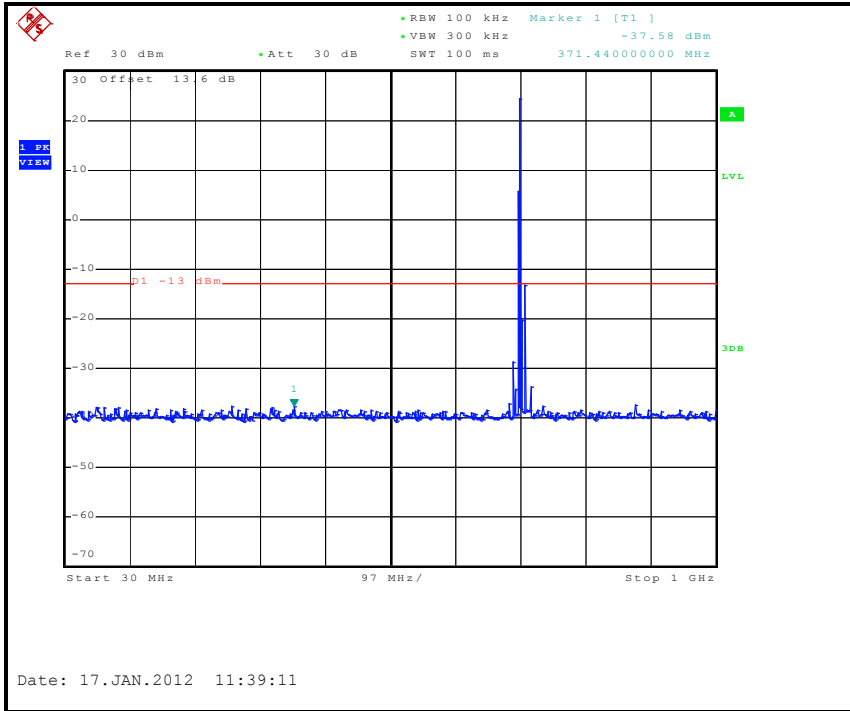

1GHz ~ 3GHz

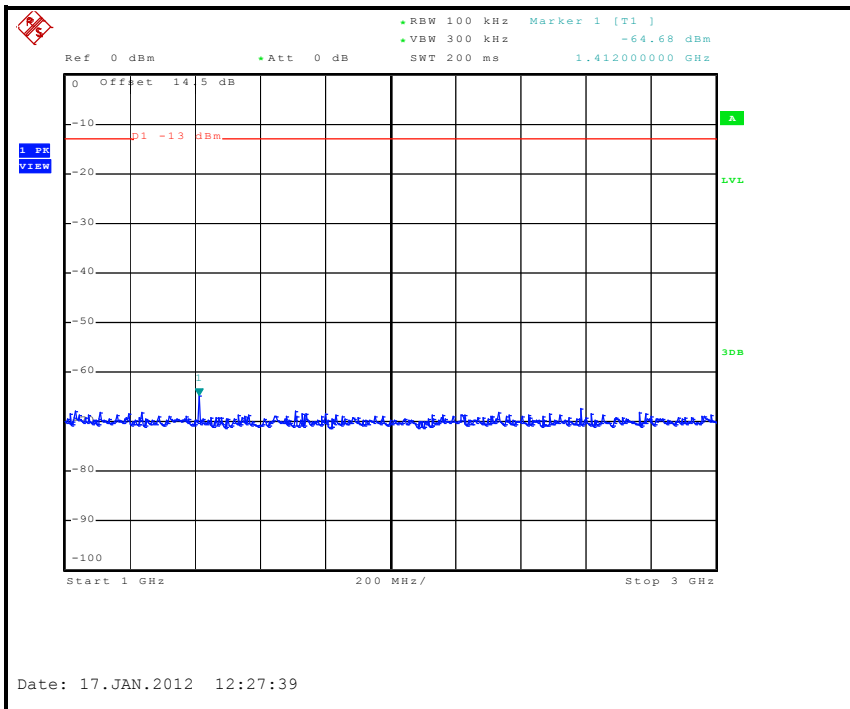



A D T

3GHz ~ 8GHz

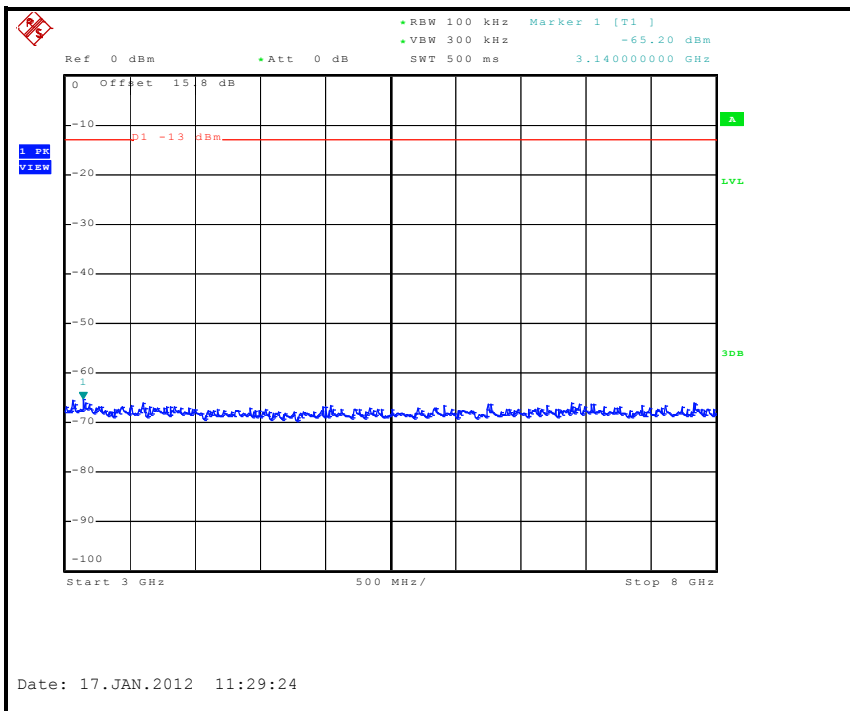

Date: 17.JAN.2012 11:29:24



A D T

LTE Band 17

CHANNEL BANDWIDTH: 10MHz / QPSK / 49 RB Offset

CH 710: 30MHz ~ 1GHz

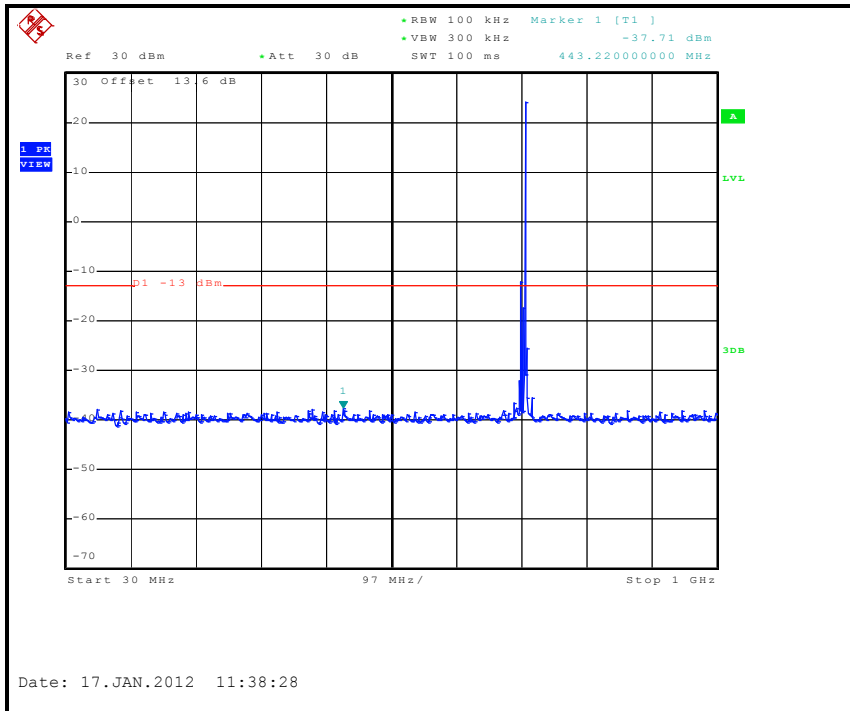

1GHz ~ 3GHz

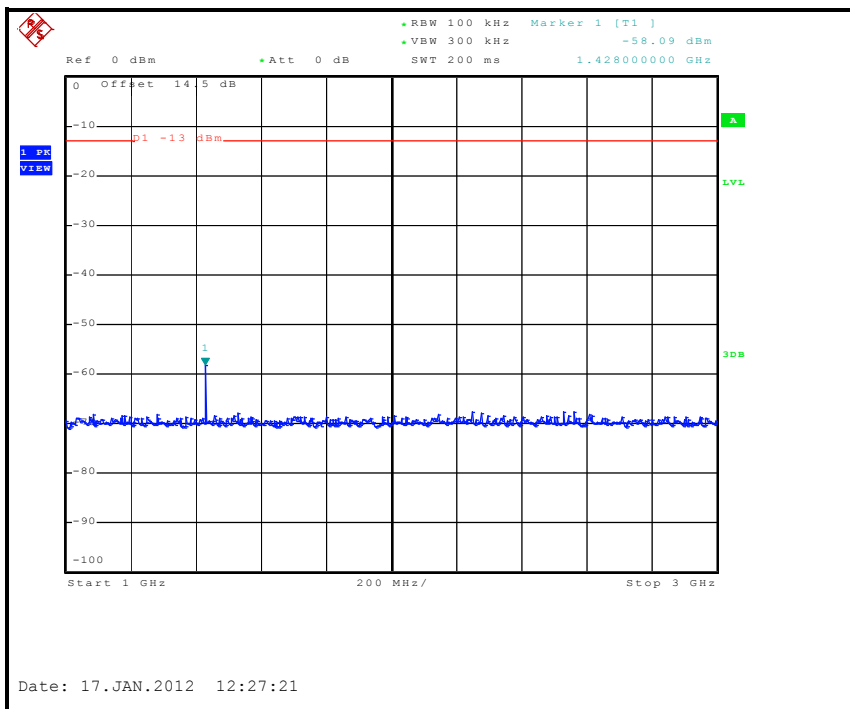



A D T

3GHz ~ 8GHz

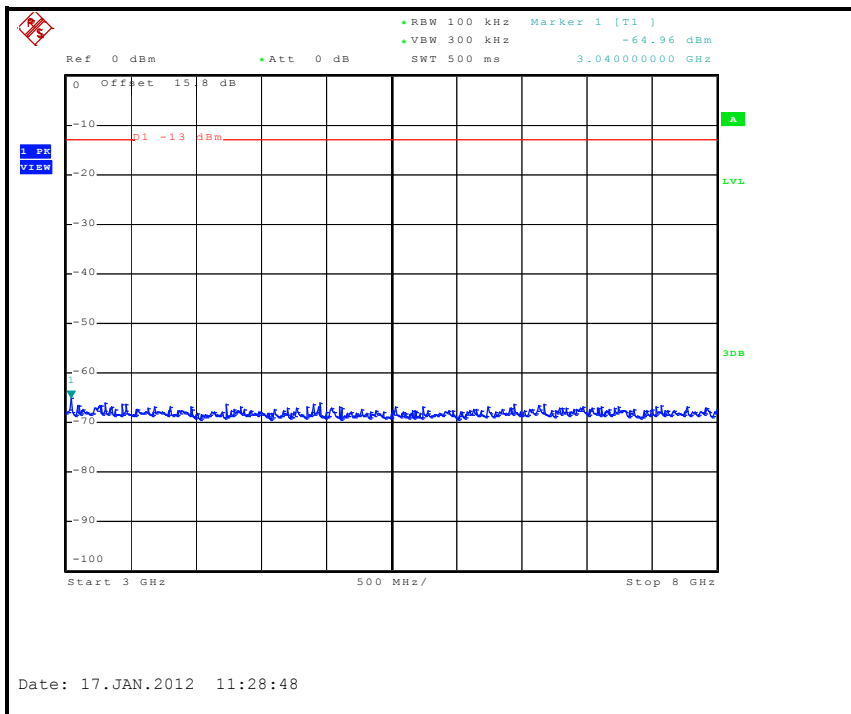



A D T

LTE Band 17

CHANNEL BANDWIDTH: 10MHz / QPSK / 0 RB Offset

CH 711: 30MHz ~ 1GHz

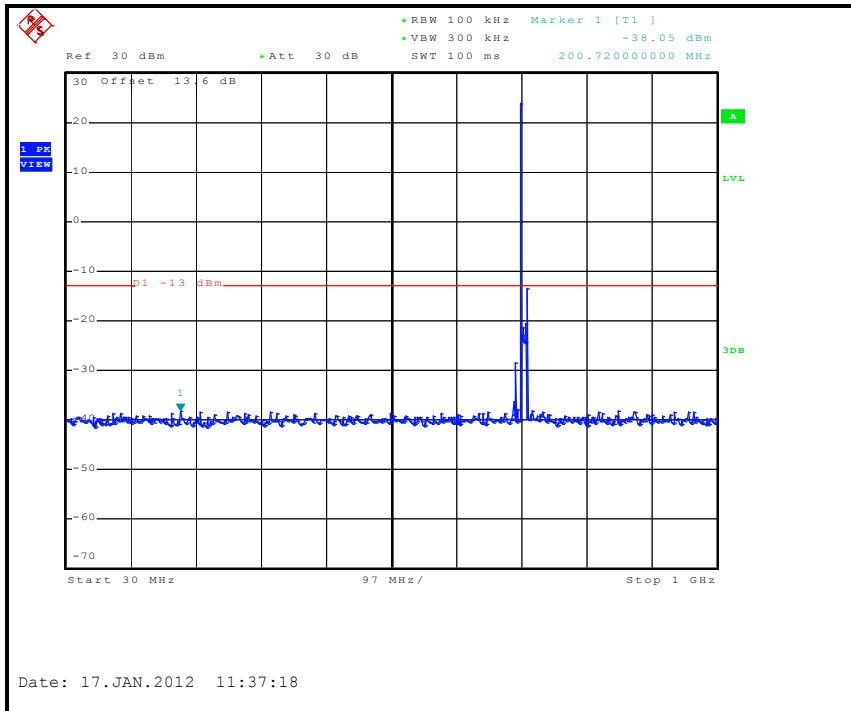

1GHz ~ 3GHz

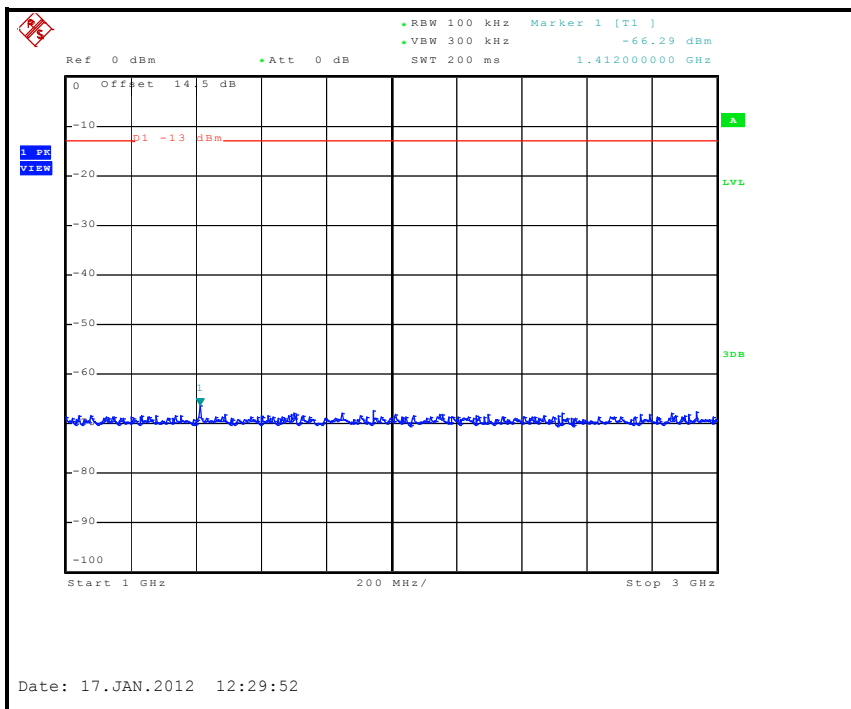



A D T

3GHz ~ 8GHz

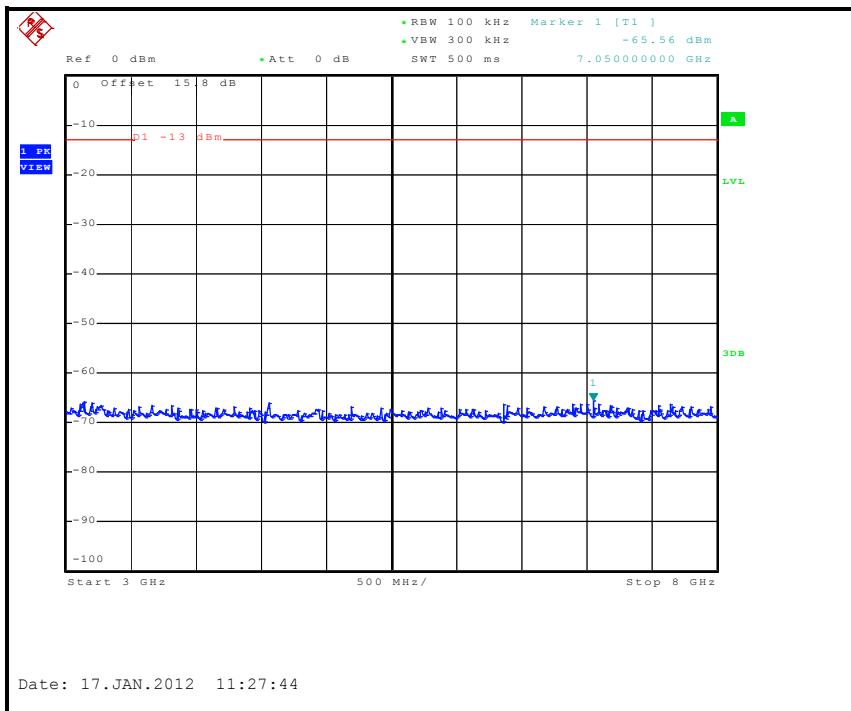

Date: 17.JAN.2012 11:27:44



A D T

LTE Band 17

CHANNEL BANDWIDTH: 10MHz / QPSK / 49 RB Offset

CH 711: 30MHz ~ 1GHz

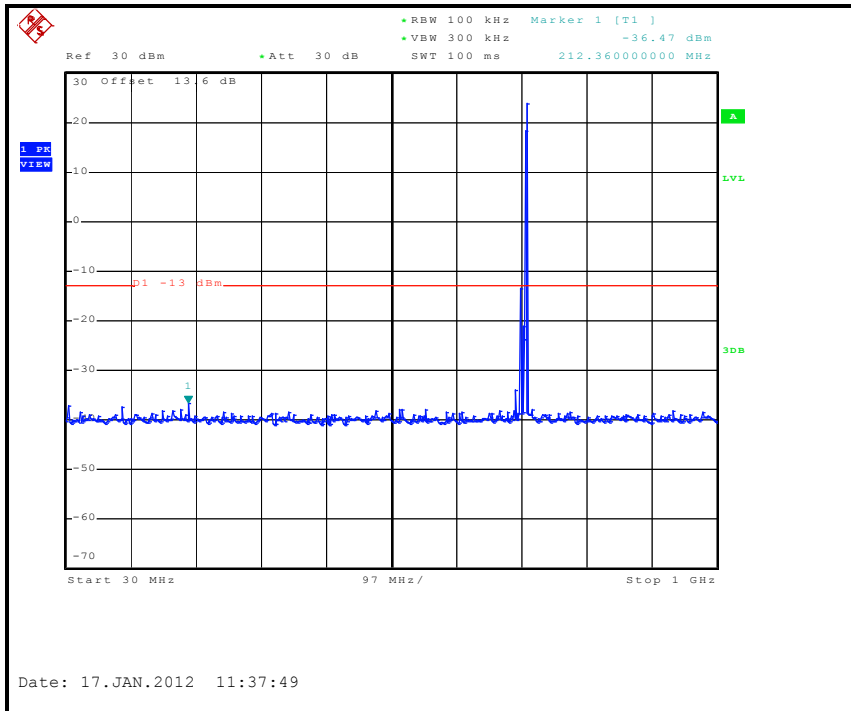

1GHz ~ 3GHz

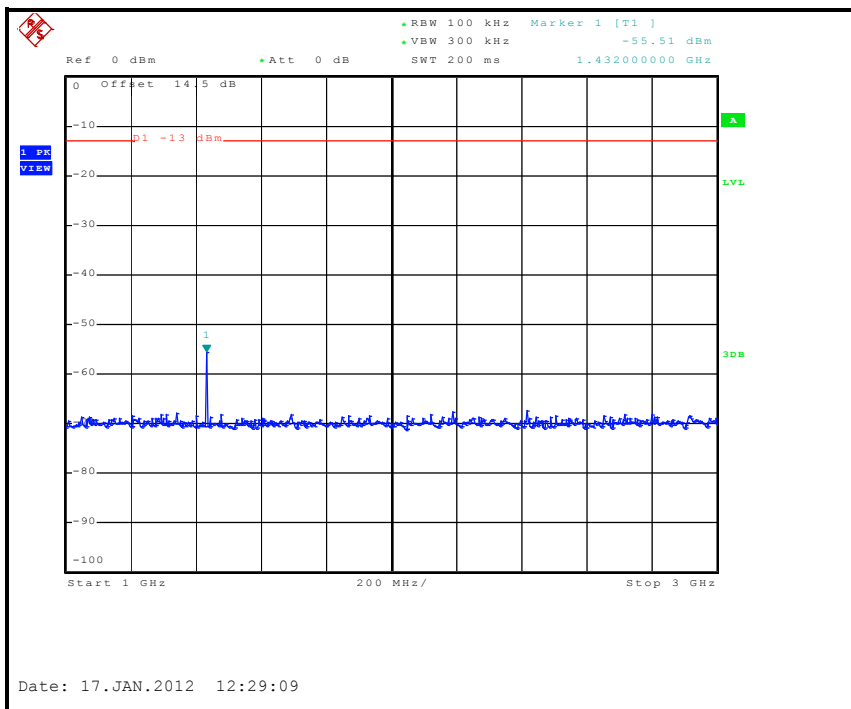



A D T

3GHz ~ 8GHz

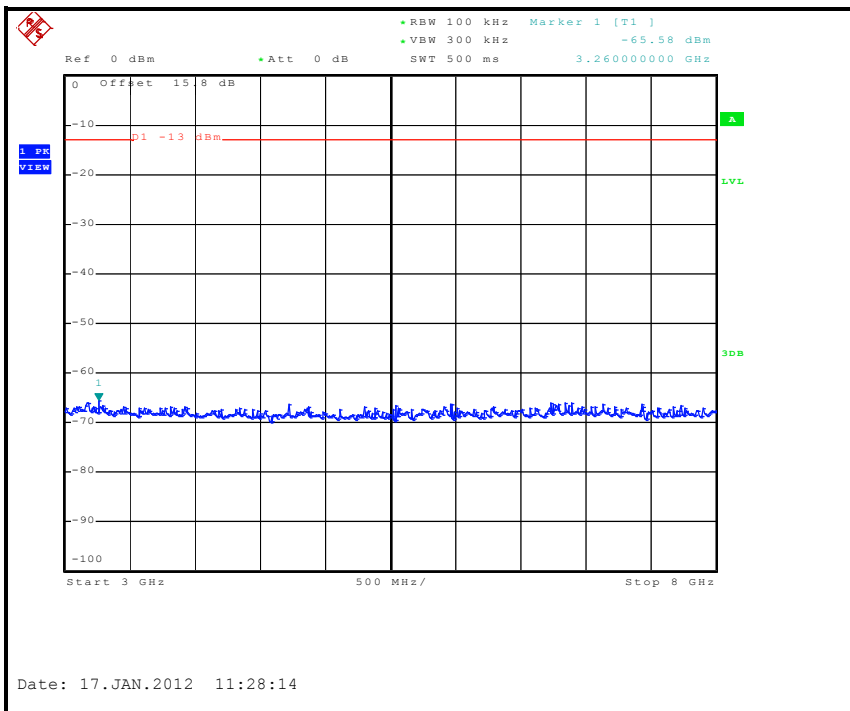



A D T

LTE Band 4
CHANNEL BANDWIDTH: 10MHz / QPSK / 0 RB Offset
CH 1712.5: 30MHz ~ 1GHz

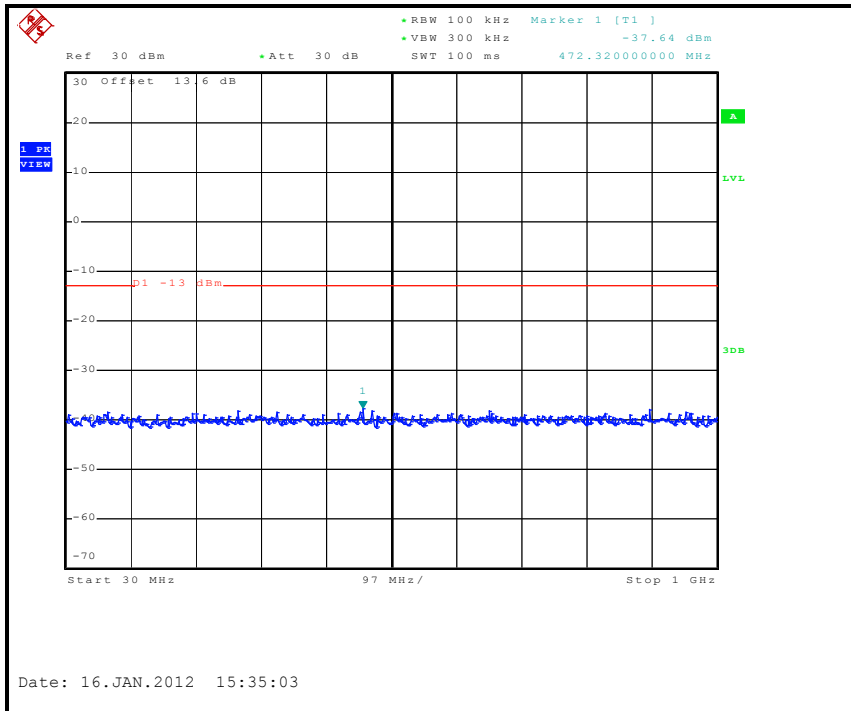

1GHz ~ 3GHz

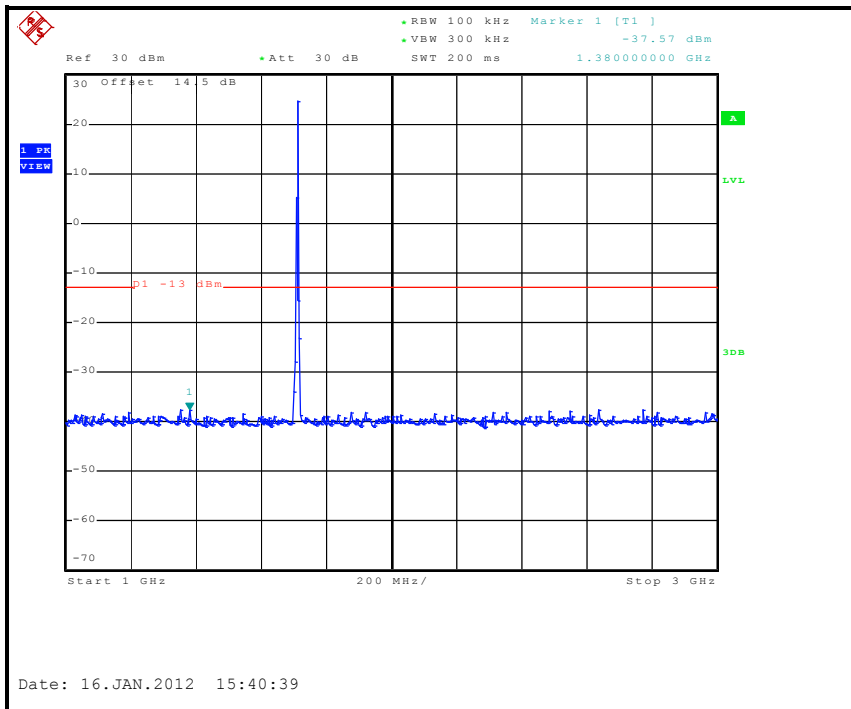



A D T

3GHz ~ 8GHz

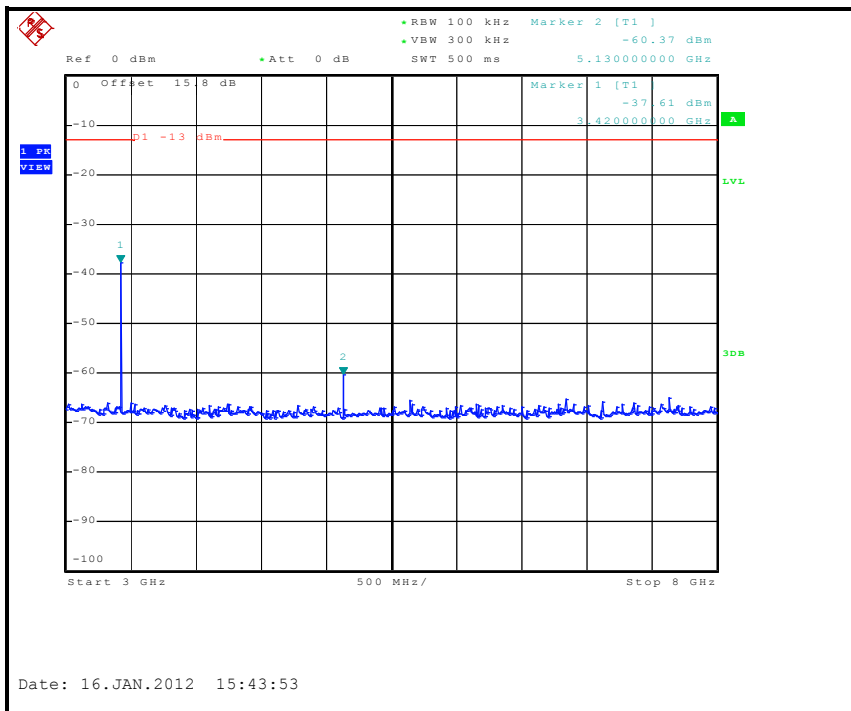

8GHz ~ 18GHz

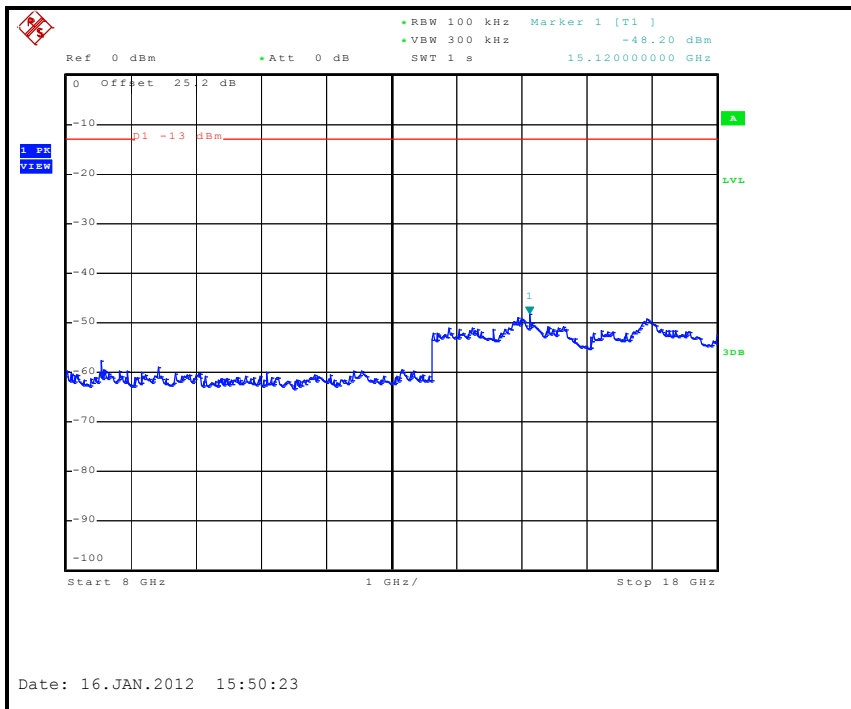



A D T

LTE Band 4 CHANNEL BANDWIDTH: 5MHz / QPSK / 24 RB Offset CH 1712.5: 30MHz ~ 1GHz

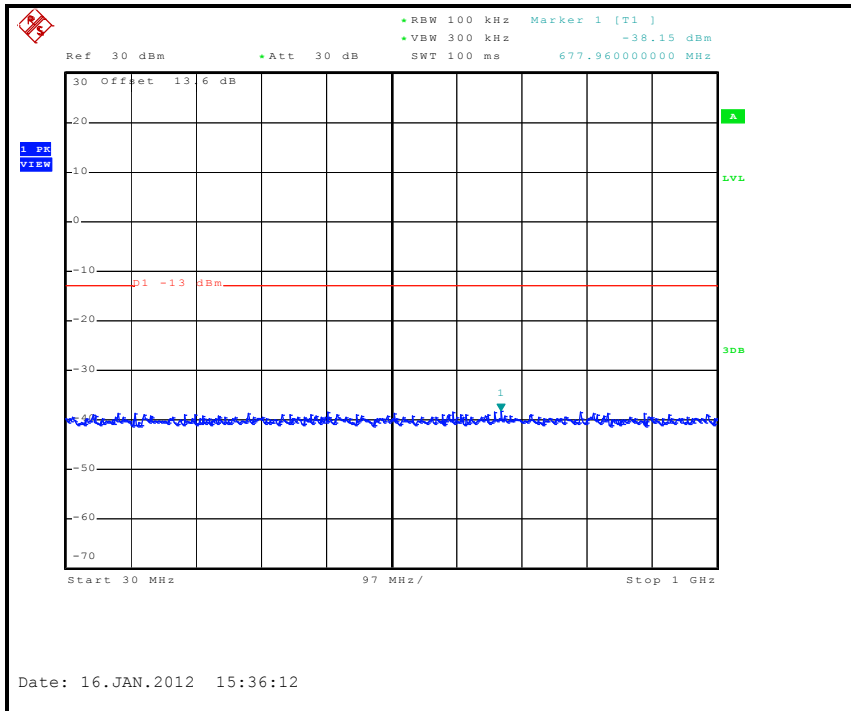

1GHz ~ 3GHz

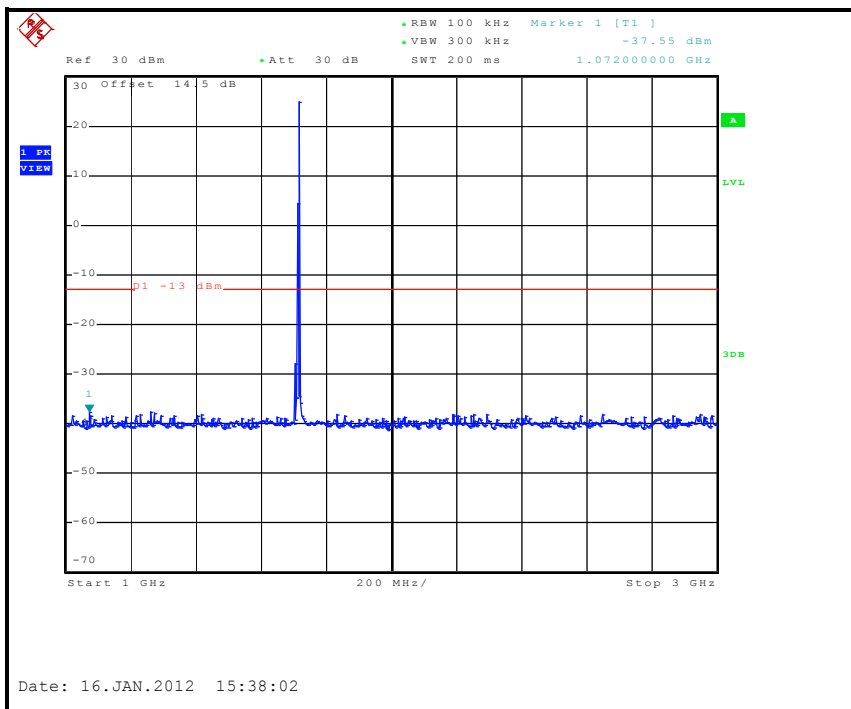



A D T

3GHz ~ 8GHz

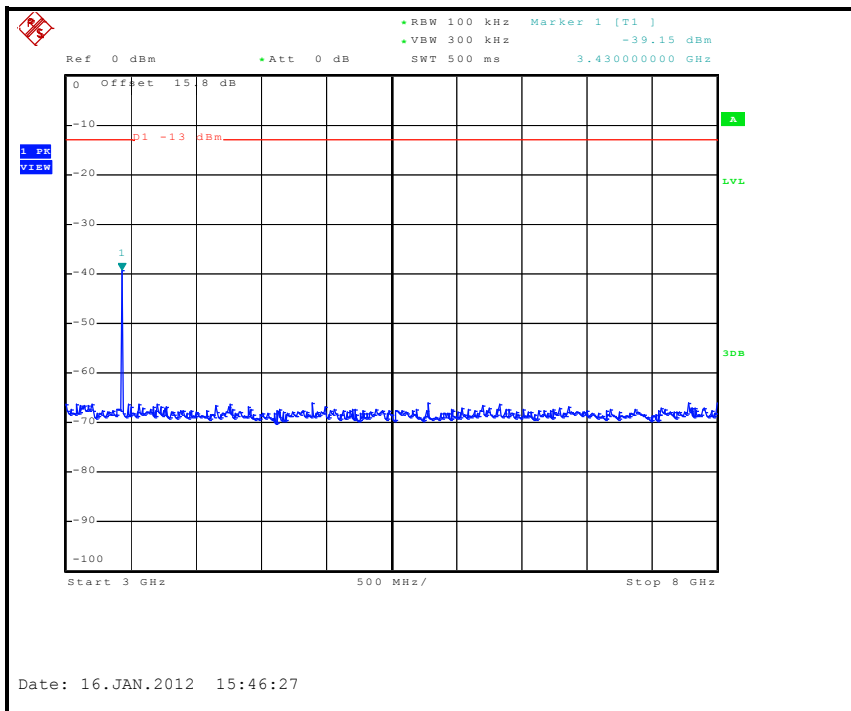

8GHz ~ 18GHz

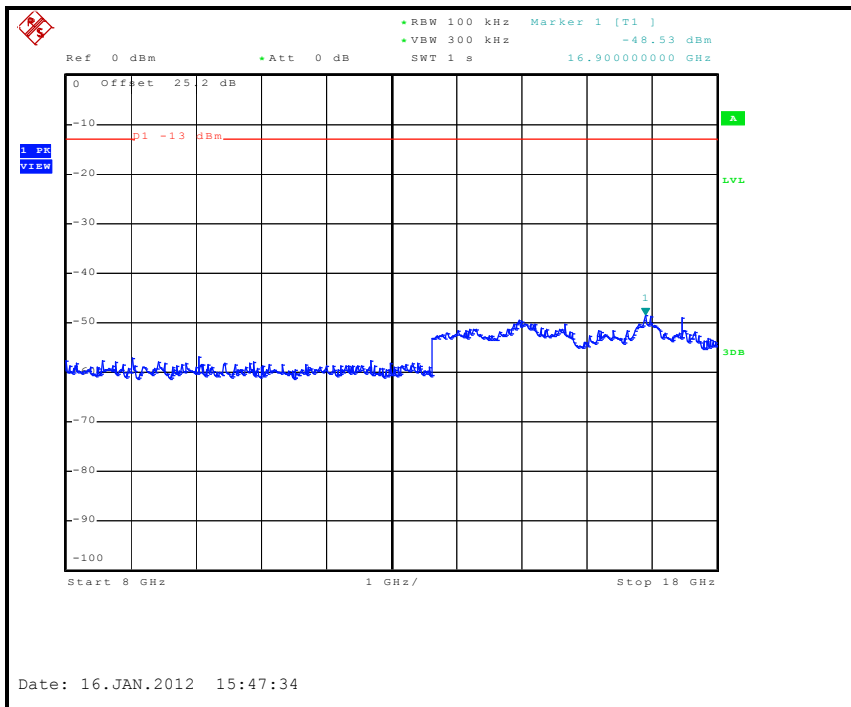



A D T

LTE Band 4
CHANNEL BANDWIDTH: 5MHz / QPSK / 0 RB Offset
CH 1732.5: 30MHz ~ 1GHz

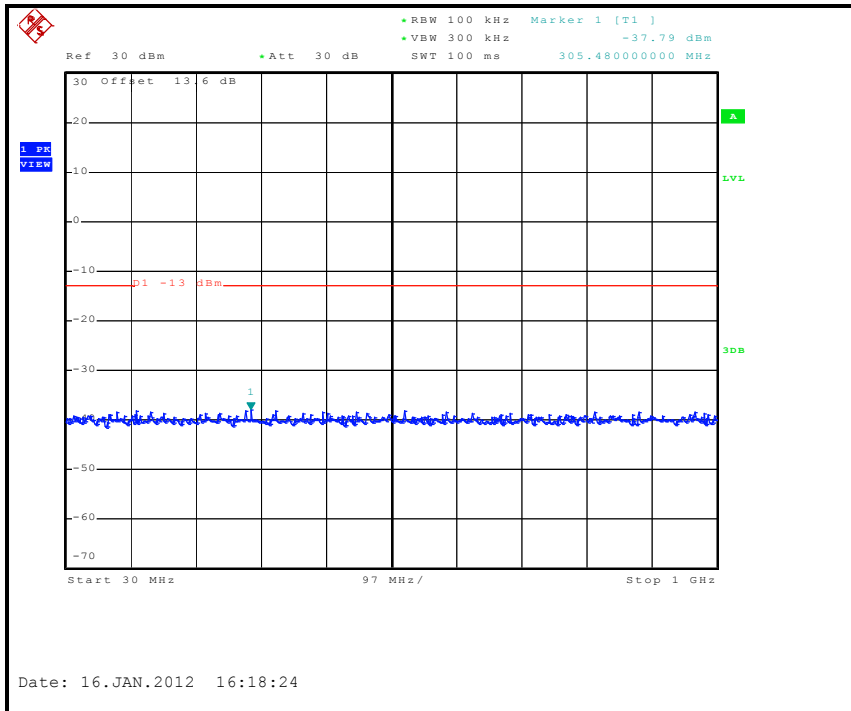

1GHz ~ 3GHz

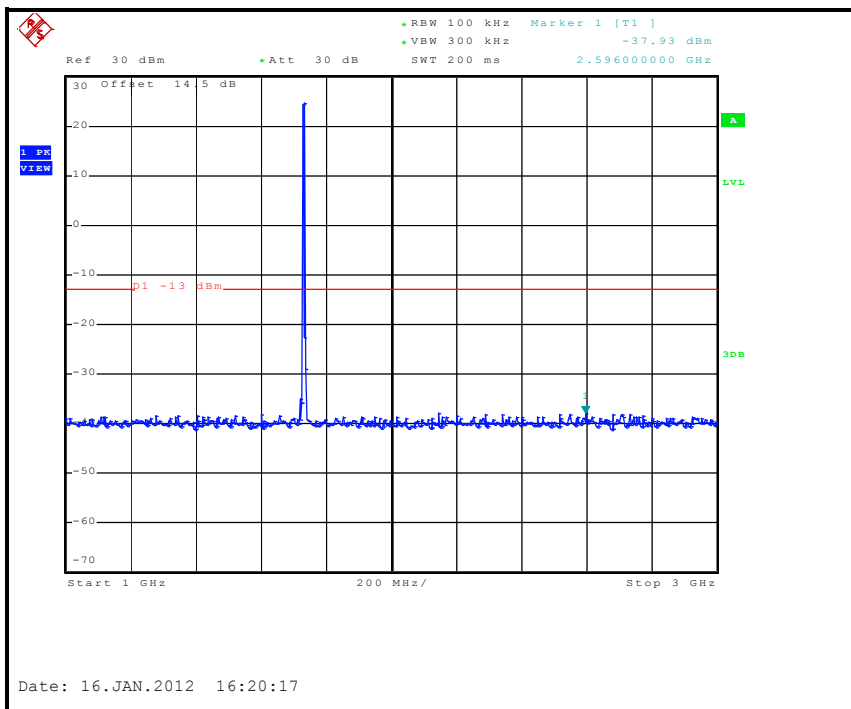



A D T

3GHz ~ 8GHz

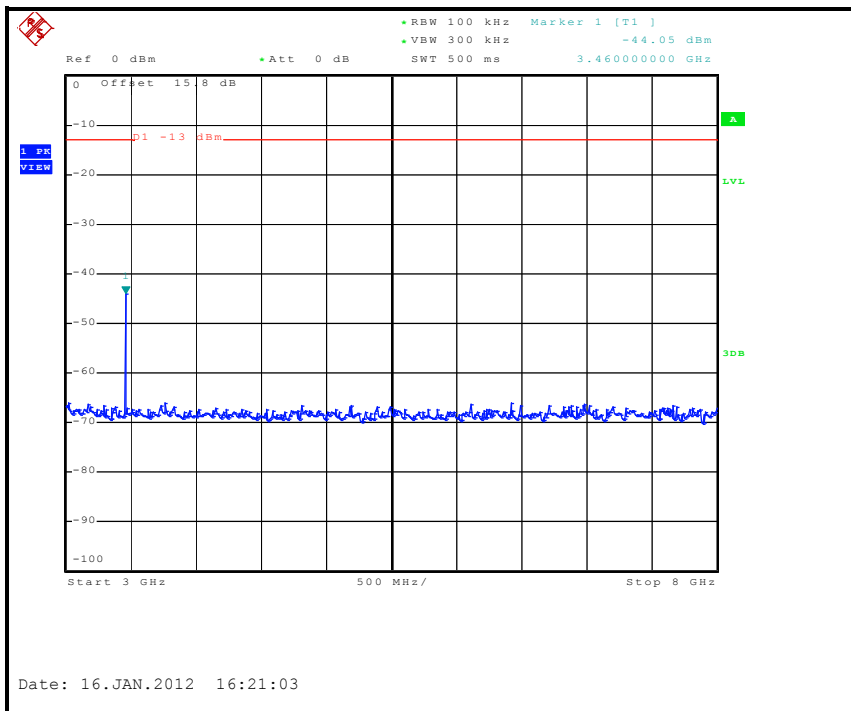

8GHz ~ 18GHz

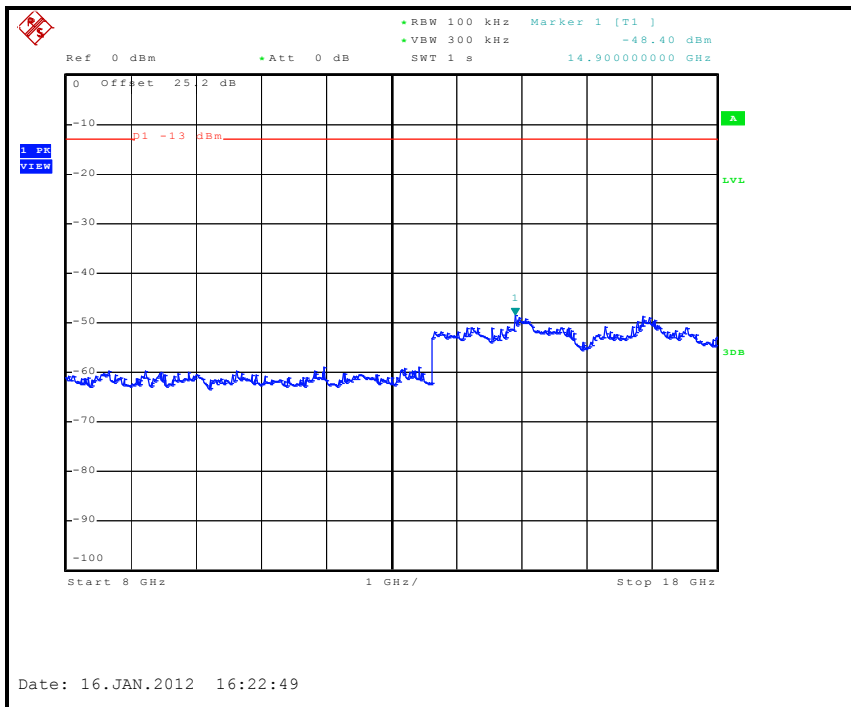



A D T

LTE Band 4
CHANNEL BANDWIDTH: 5MHz / QPSK / 24 RB Offset
CH 1732.5: 30MHz ~ 1GHz

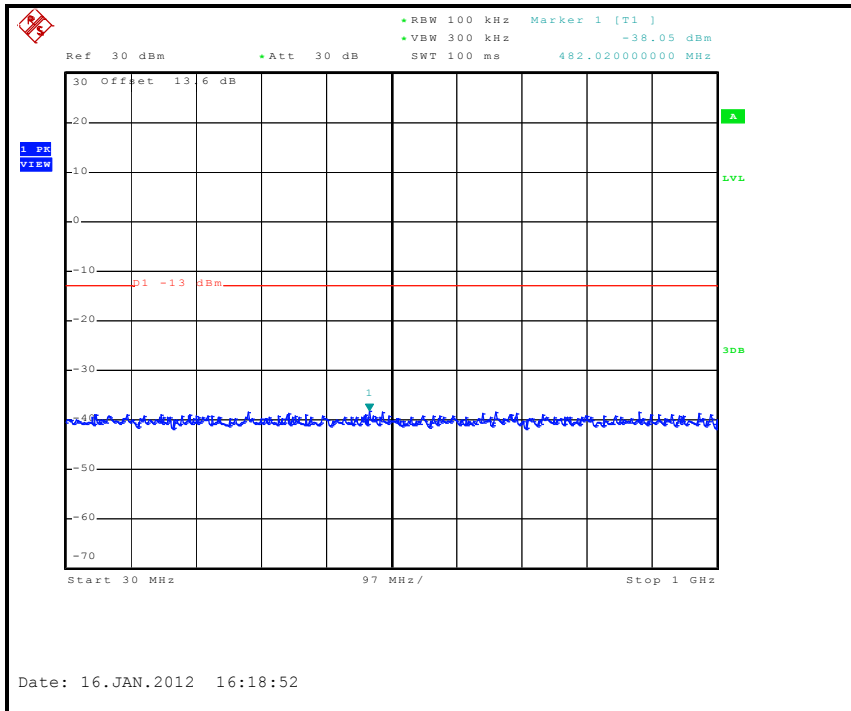

1GHz ~ 3GHz

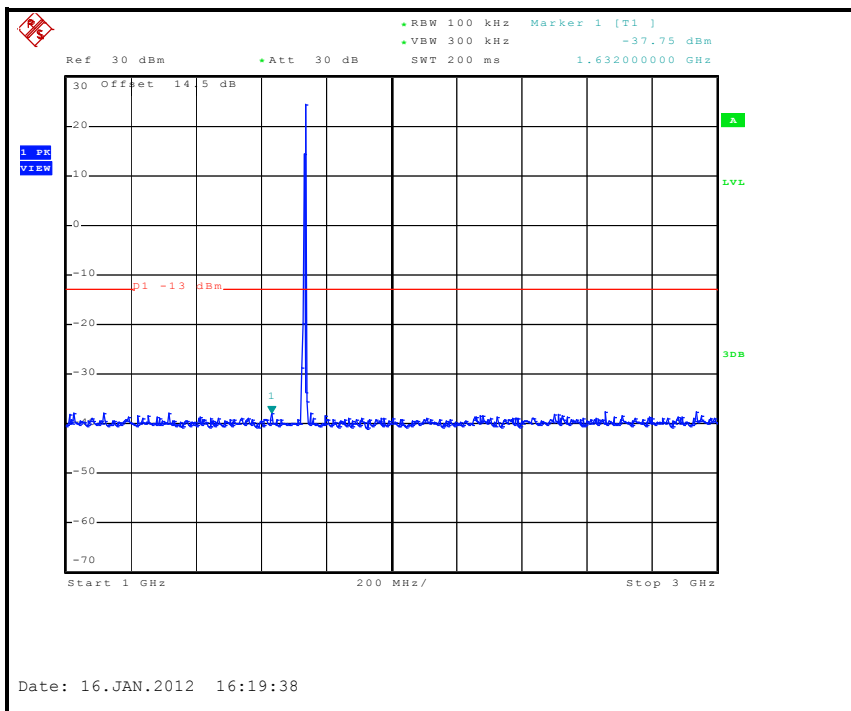



A D T

3GHz ~ 8GHz

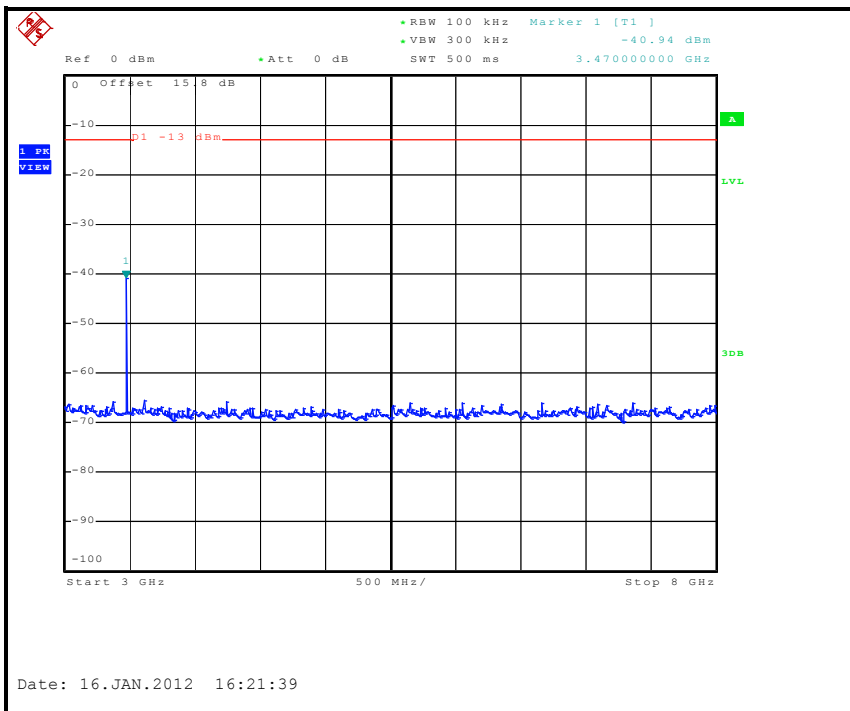

8GHz ~ 18GHz

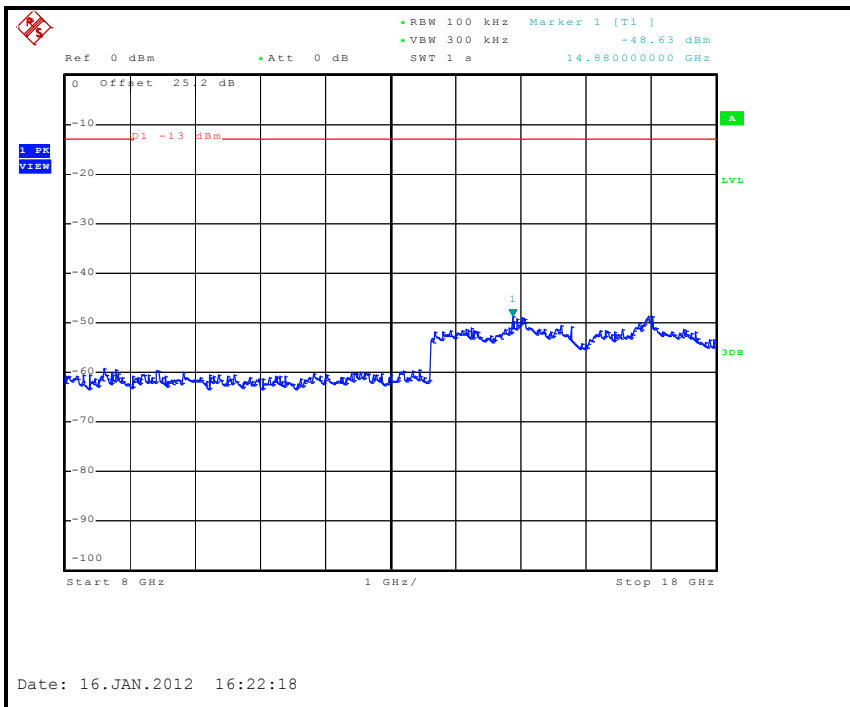



A D T

LTE Band 4
CHANNEL BANDWIDTH: 5MHz / QPSK / 0 RB Offset
CH 1752.5: 30MHz ~ 1GHz

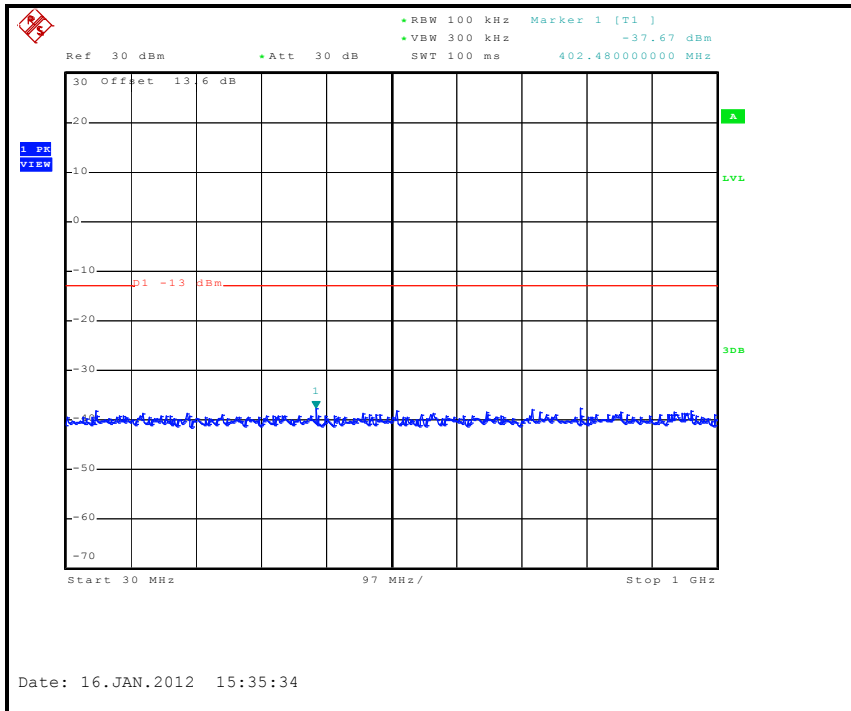

1GHz ~ 3GHz

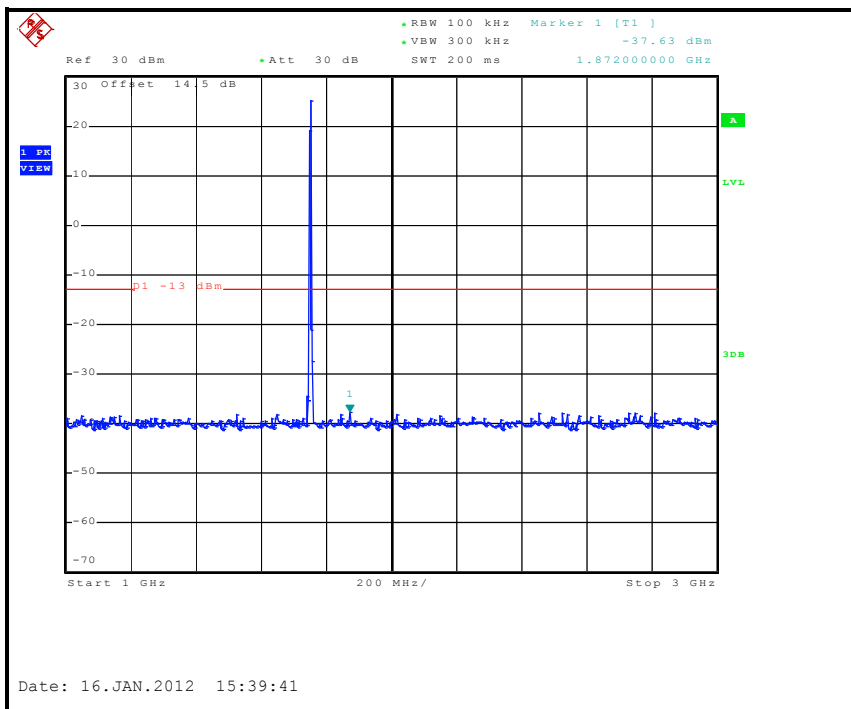



A D T

3GHz ~ 8GHz

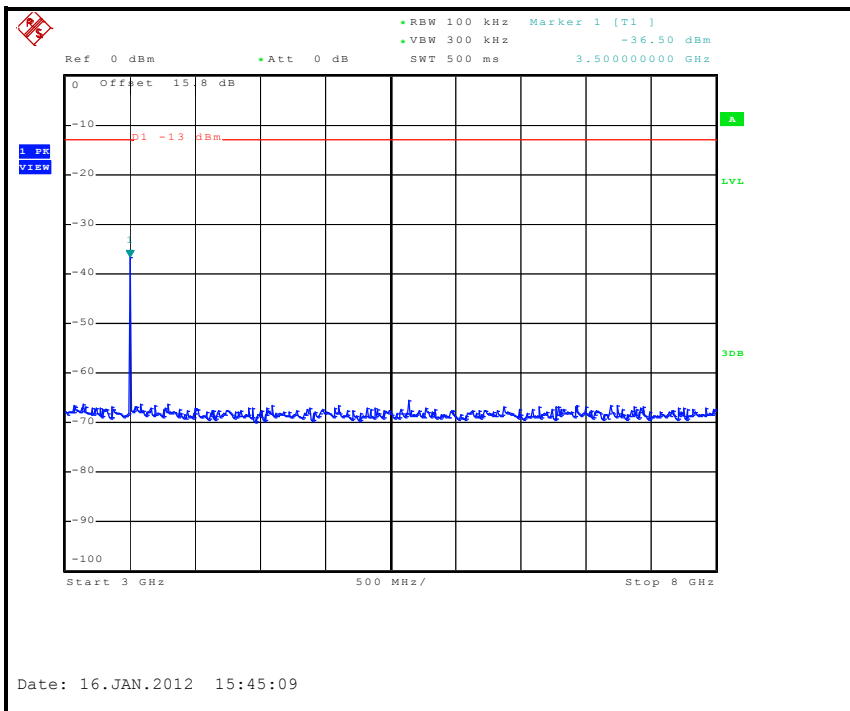

8GHz ~ 18GHz

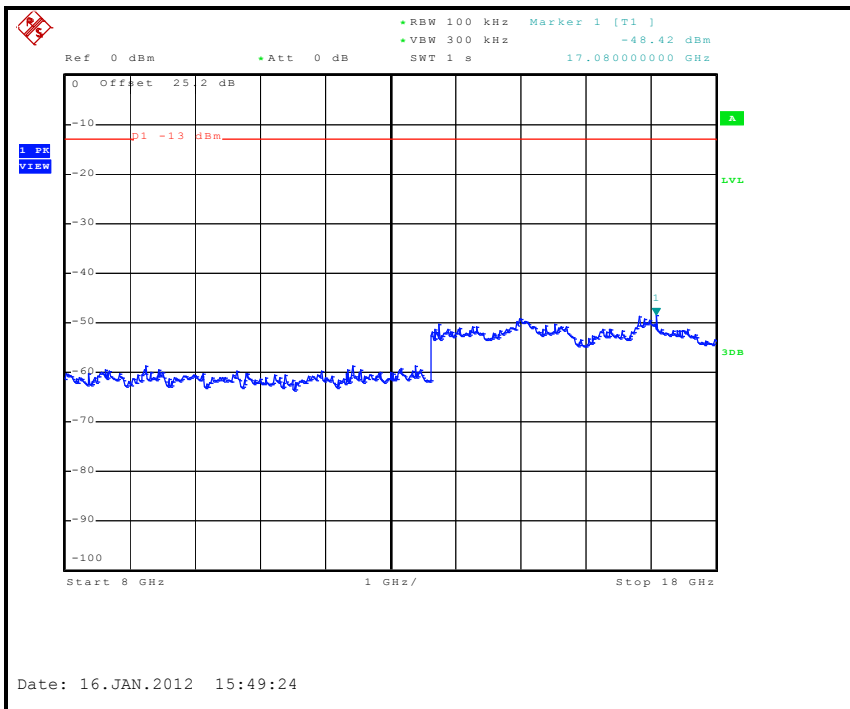



A D T

LTE Band 4

CHANNEL BANDWIDTH: 5MHz / QPSK / 24 RB Offset

CH 1752.5: 30MHz ~ 1GHz

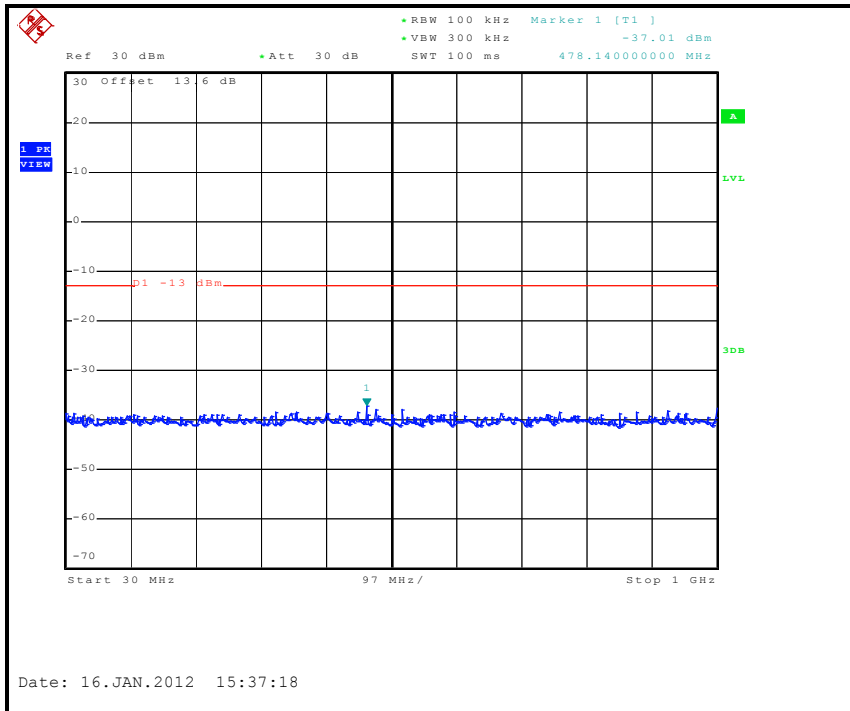

1GHz ~ 3GHz

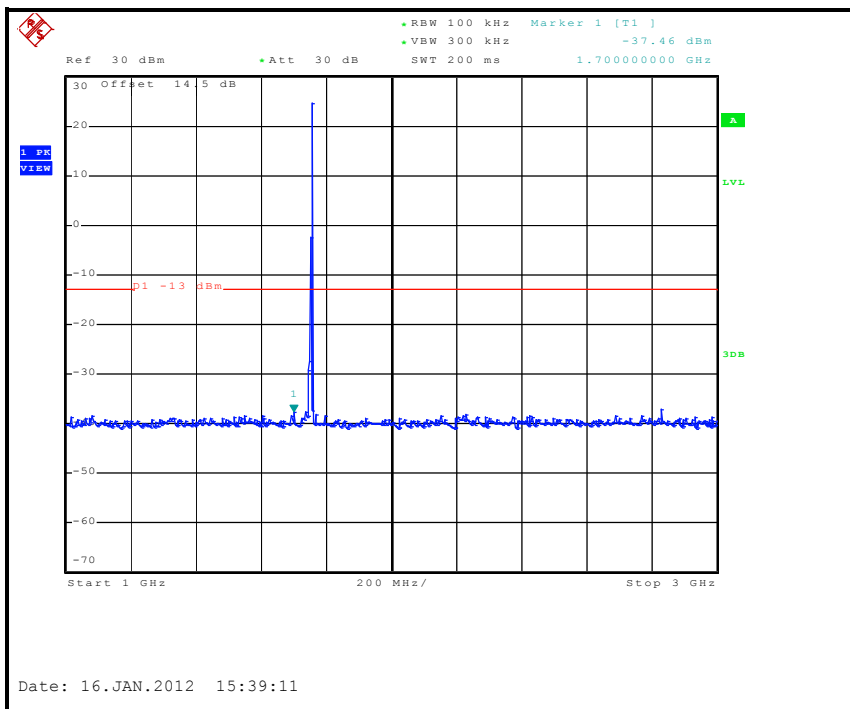



A D T

3GHz ~ 8GHz

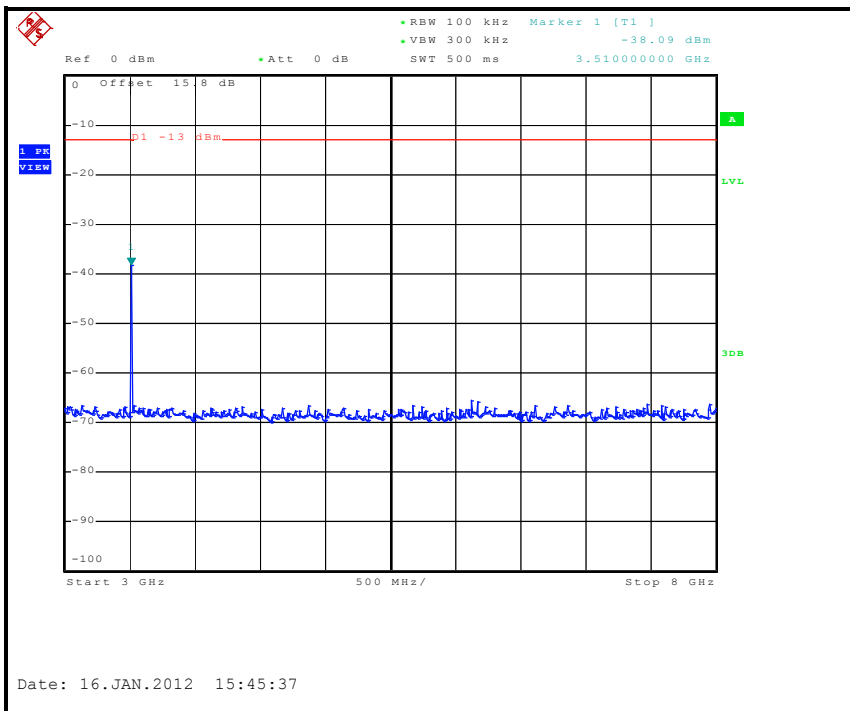

8GHz ~ 18GHz

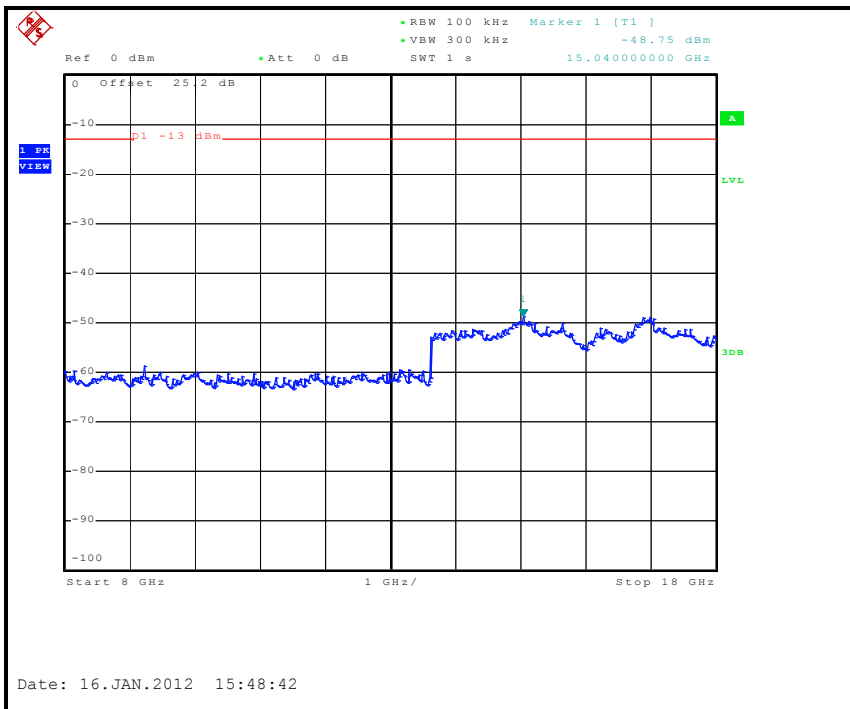



A D T

LTE Band 4
CHANNEL BANDWIDTH: 10MHz / QPSK / 0 RB Offset
CH 1715: 30MHz ~ 1GHz

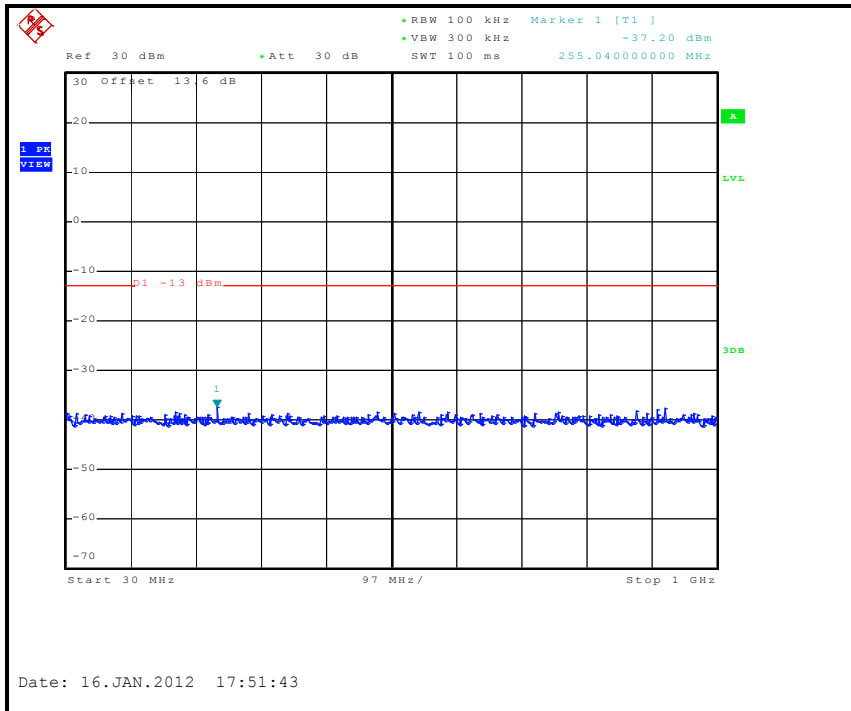

1GHz ~ 3GHz

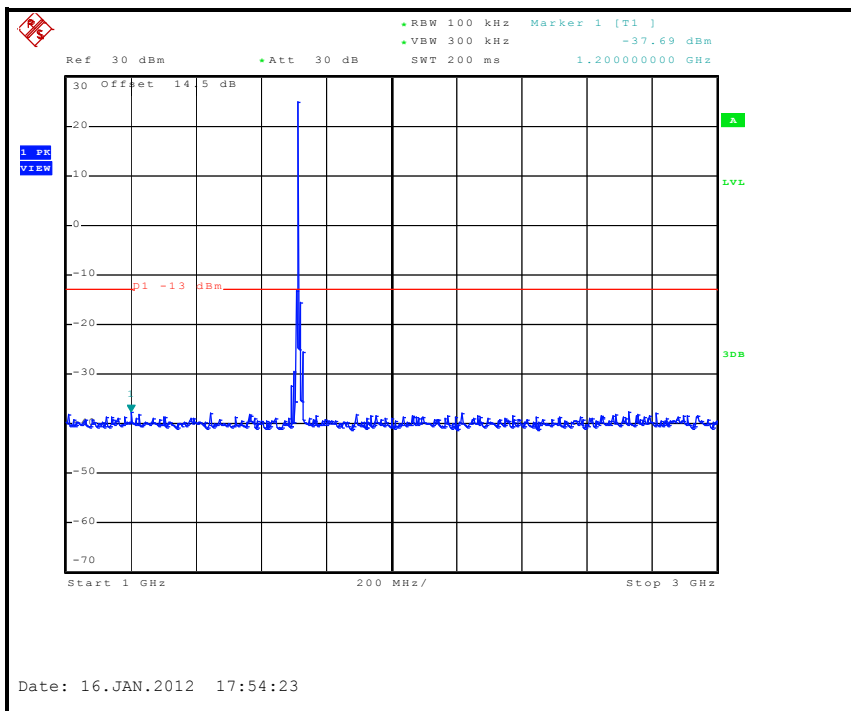

3GHz ~ 8GHz

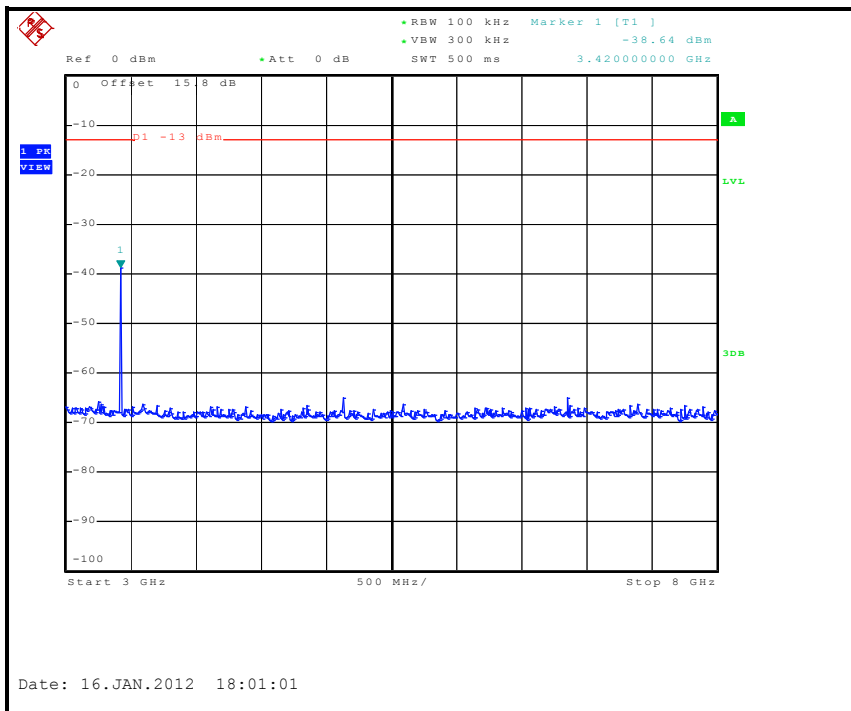

8GHz ~ 18GHz

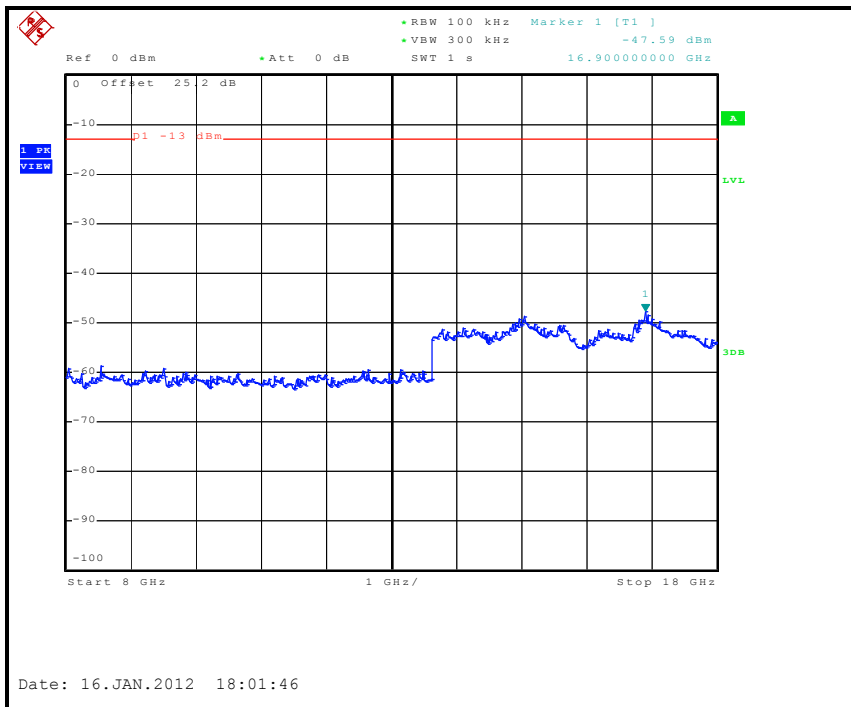



A D T

LTE Band 4

CHANNEL BANDWIDTH: 10MHz / QPSK / 49 RB Offset

CH 1715: 30MHz ~ 1GHz

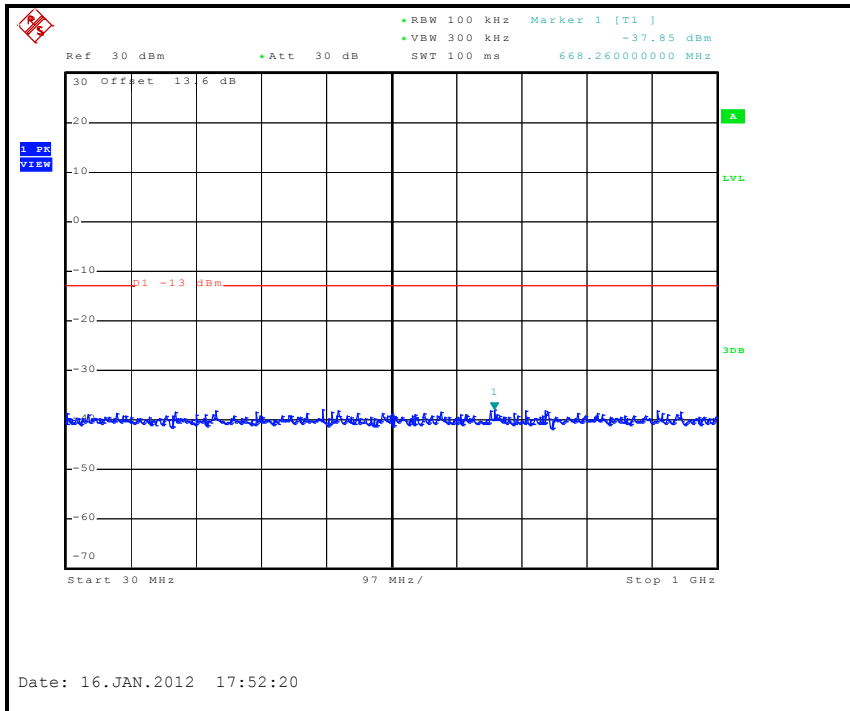

1GHz ~ 3GHz

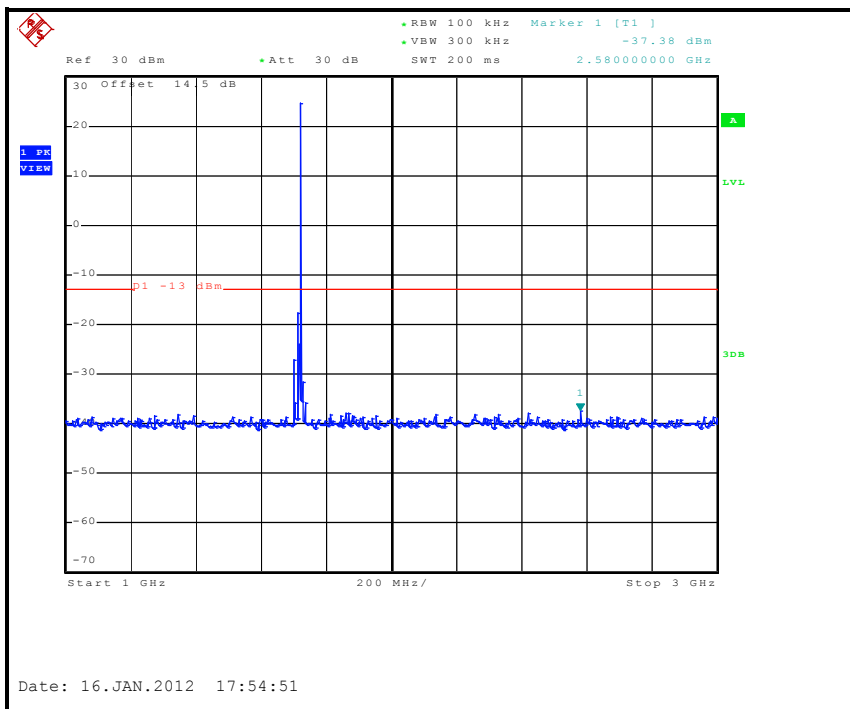



A D T

LTE Band 4

CHANNEL BANDWIDTH: 10MHz / QPSK / 0 RB Offset

CH 1732.5: 30MHz ~ 1GHz

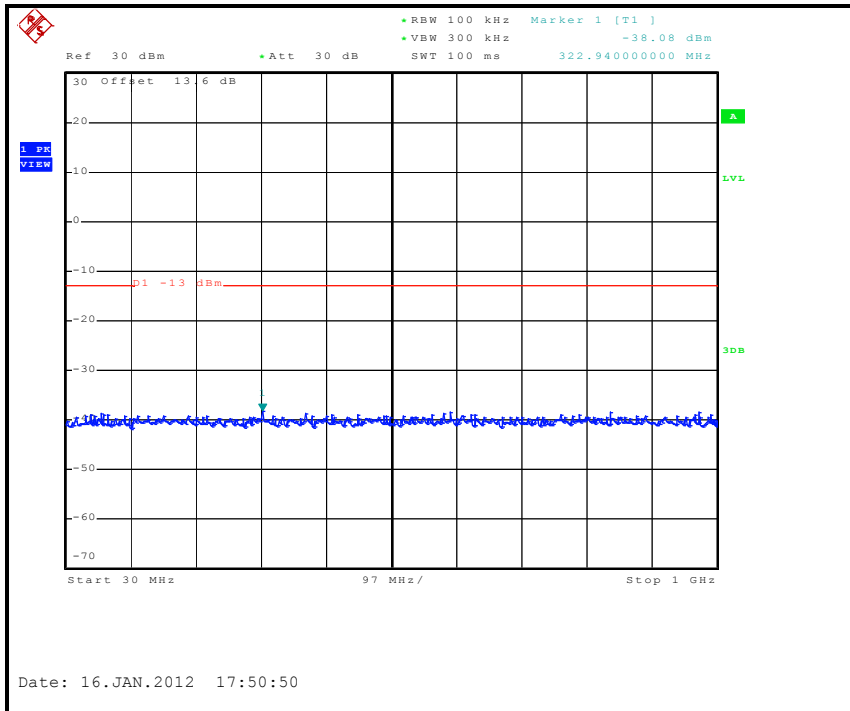

1GHz ~ 3GHz

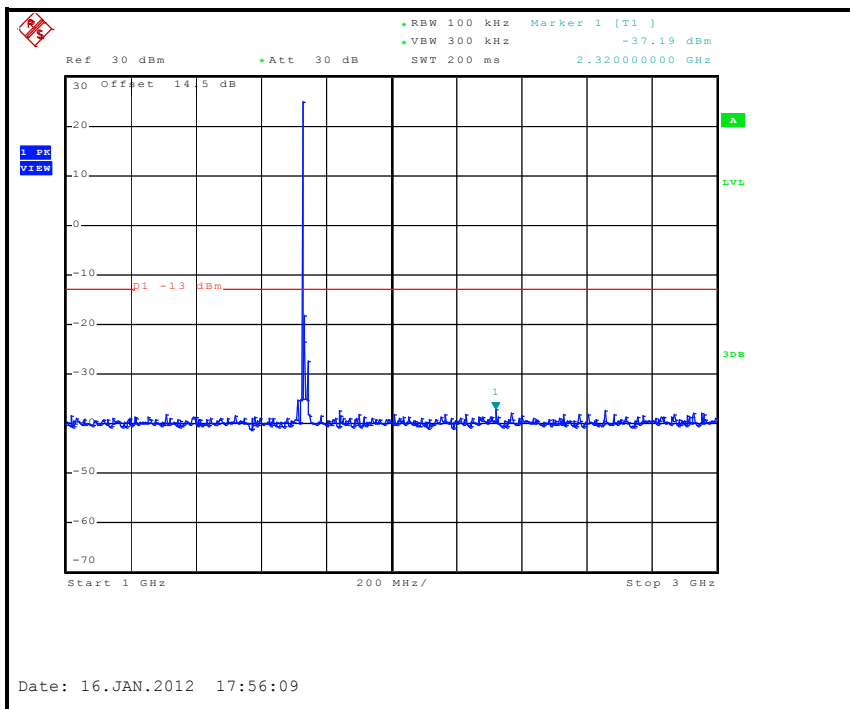



A D T

3GHz ~ 8GHz

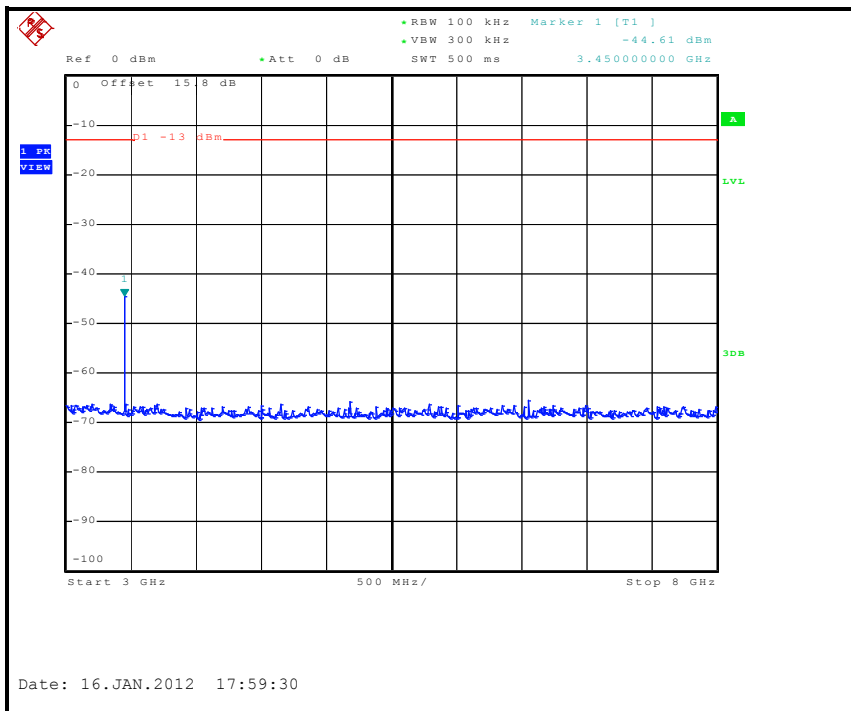

8GHz ~ 18GHz

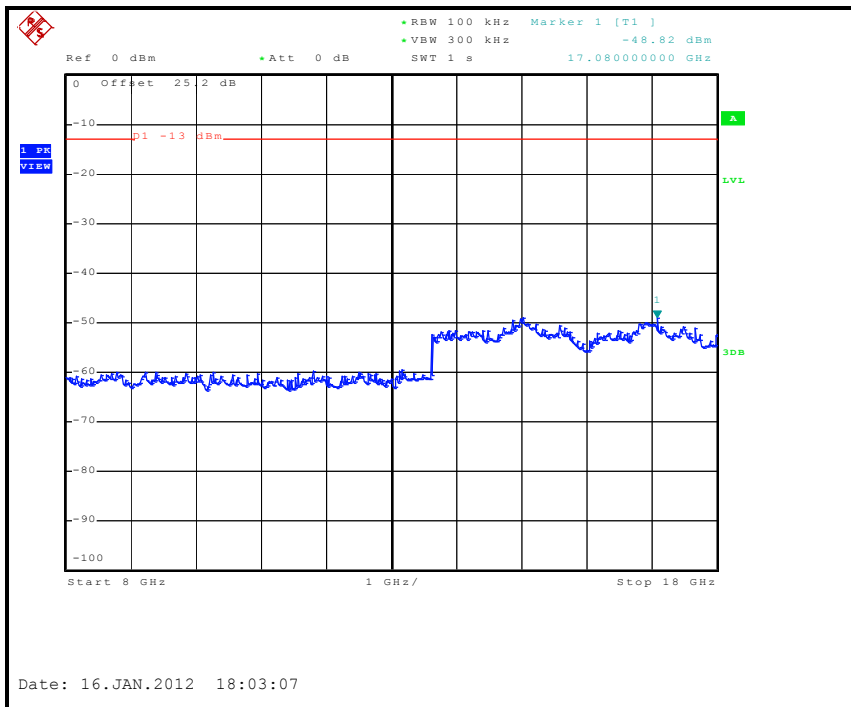



A D T

LTE Band 4

CHANNEL BANDWIDTH: 10MHz / QPSK / 49 RB Offset

CH 1732.5: 30MHz ~ 1GHz

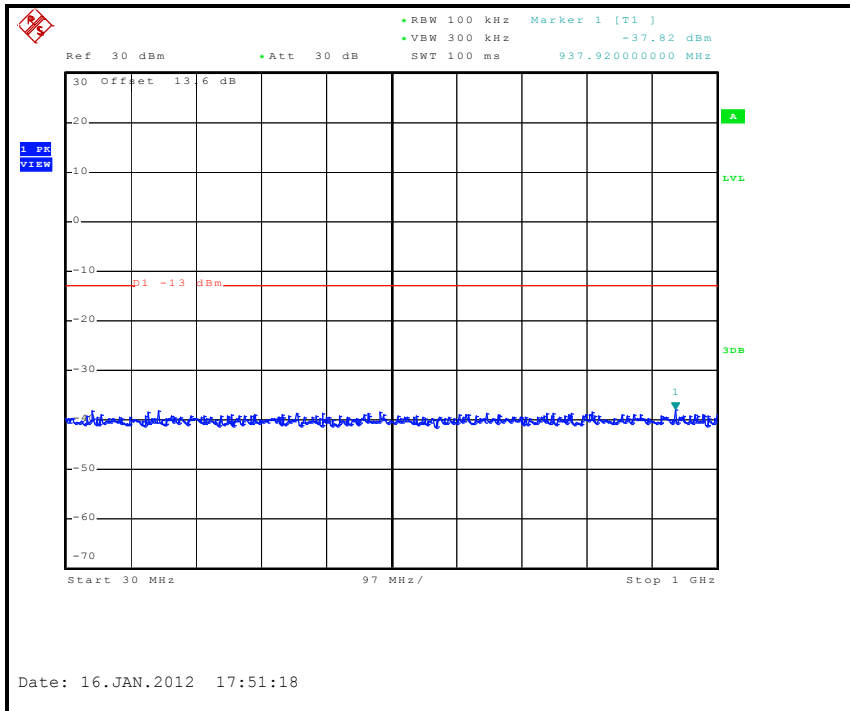

1GHz ~ 3GHz

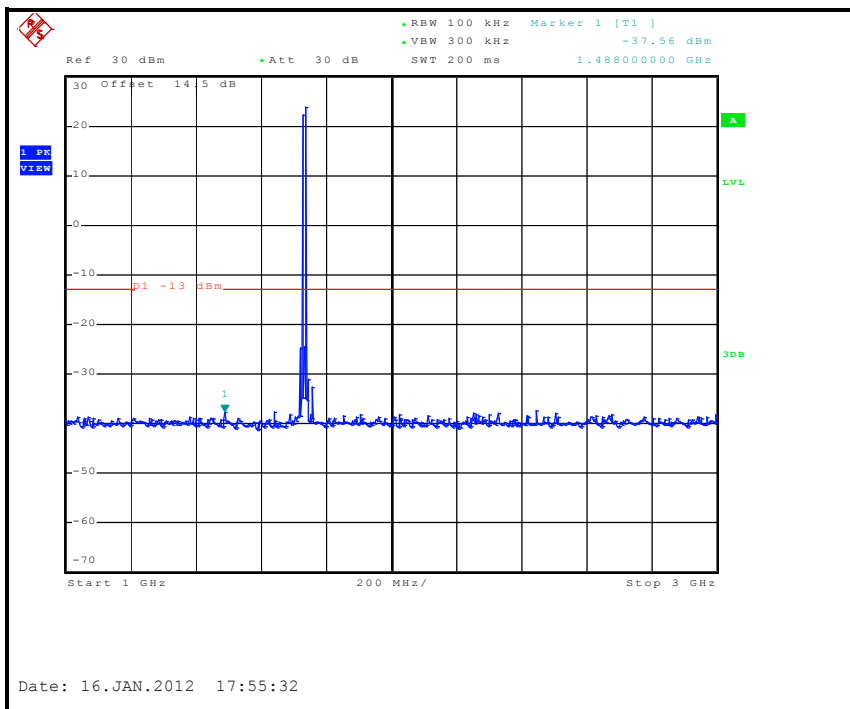



A D T

3GHz ~ 8GHz

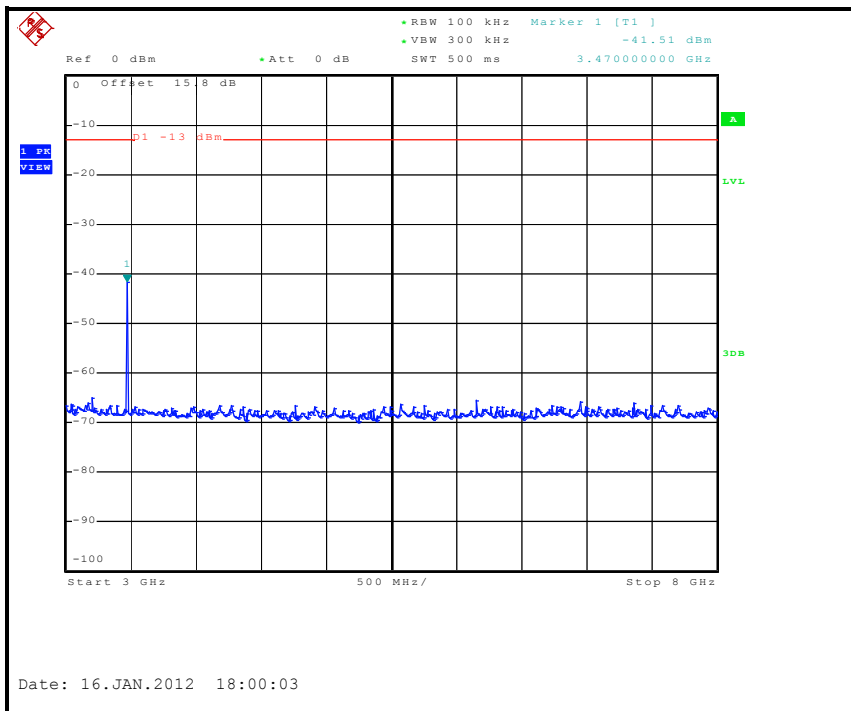

8GHz ~ 18GHz

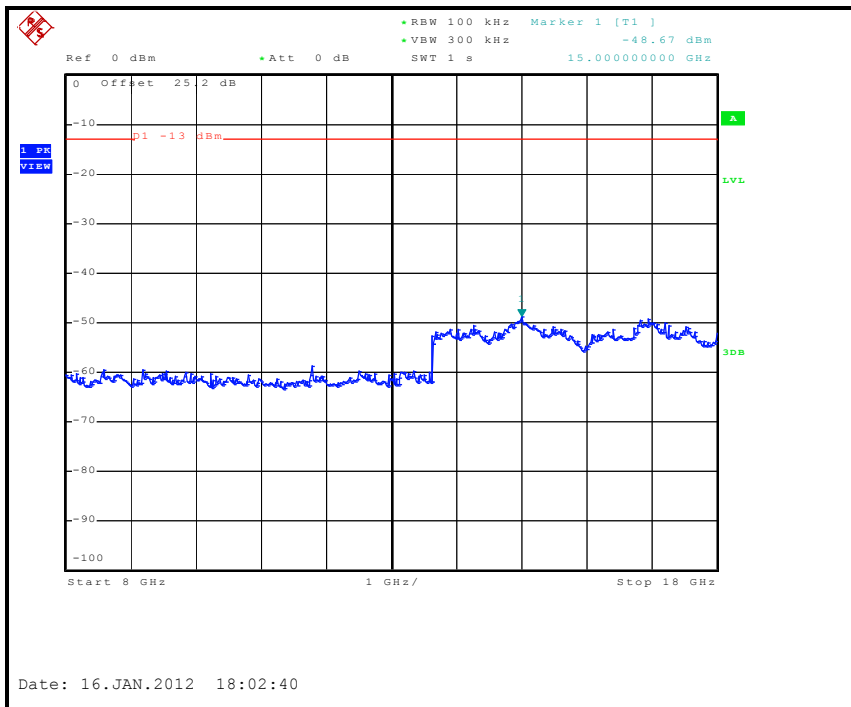



A D T

LTE Band 4
CHANNEL BANDWIDTH: 10MHz / QPSK / 0 RB Offset
CH 1750: 30MHz ~ 1GHz

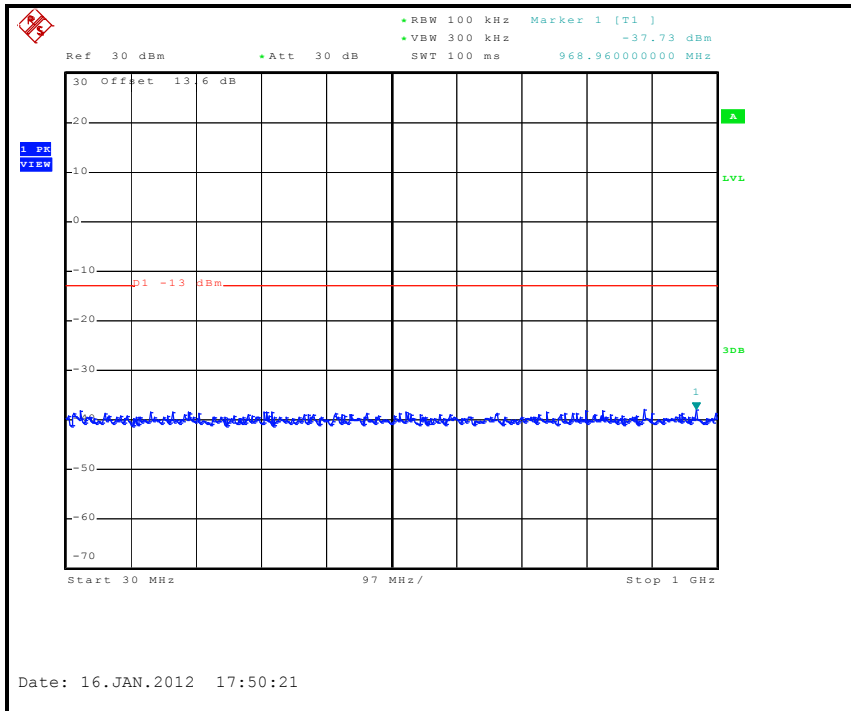

1GHz ~ 3GHz

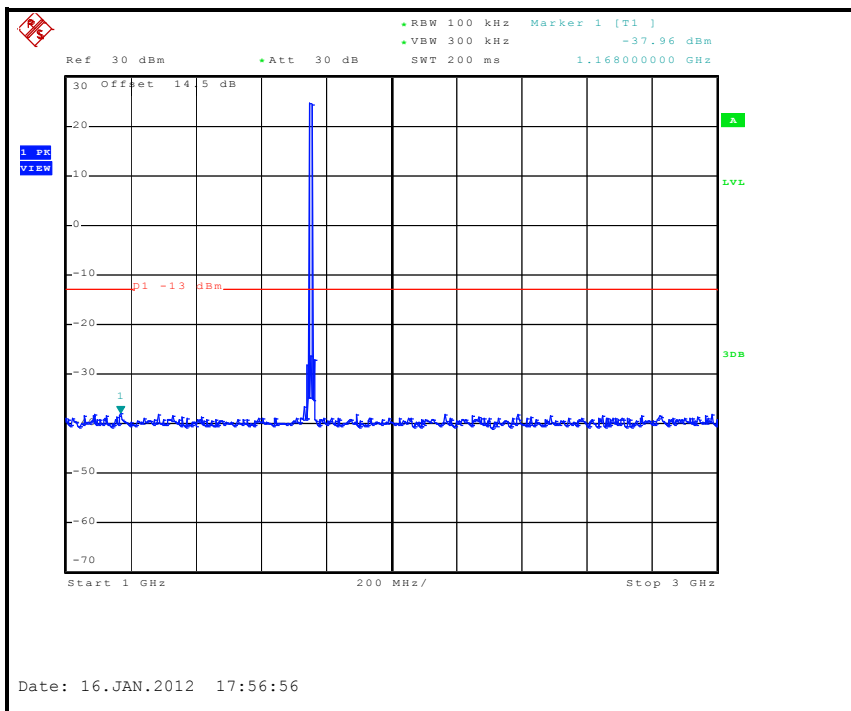



A D T

3GHz ~ 8GHz

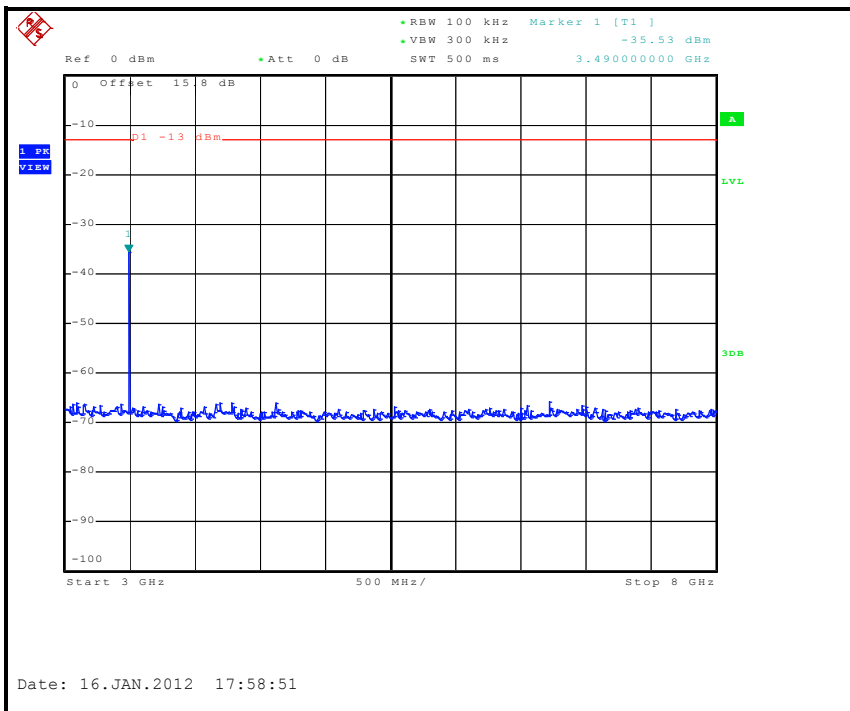

8GHz ~ 18GHz

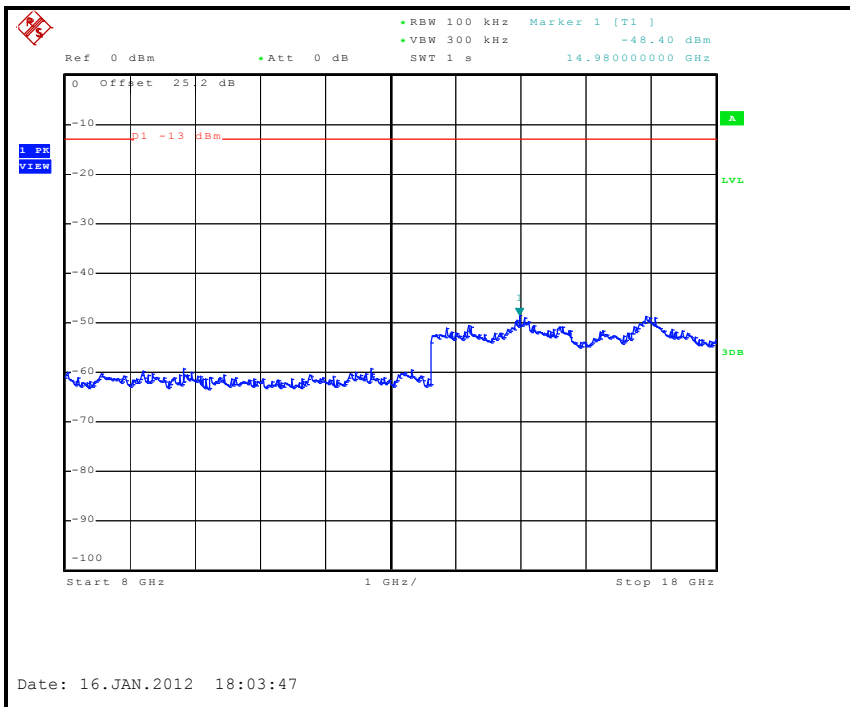



A D T

LTE Band 4
CHANNEL BANDWIDTH: 10MHz / QPSK / 49 RB Offset
CH 1750: 30MHz ~ 1GHz

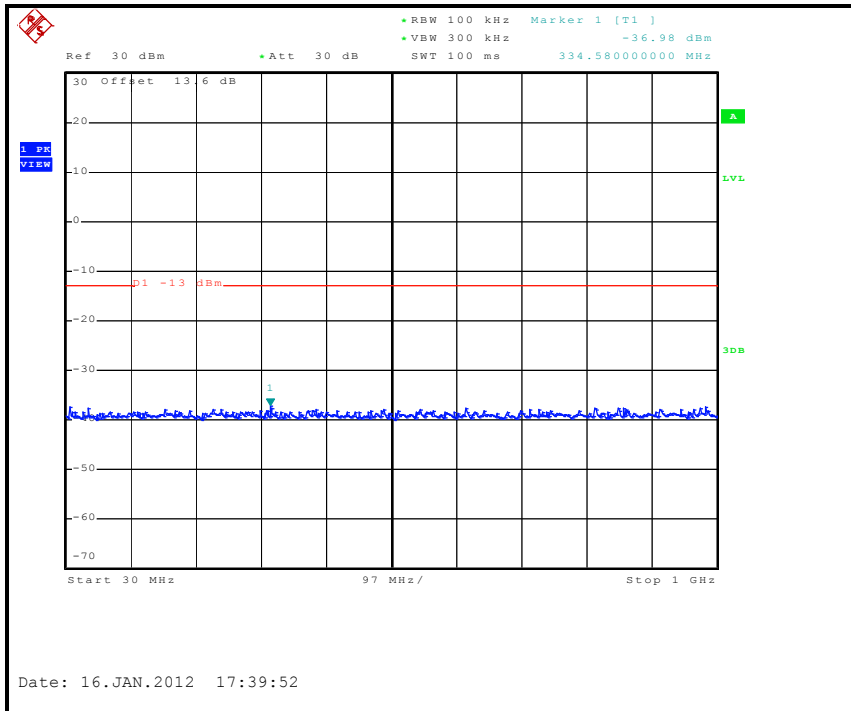

1GHz ~ 3GHz

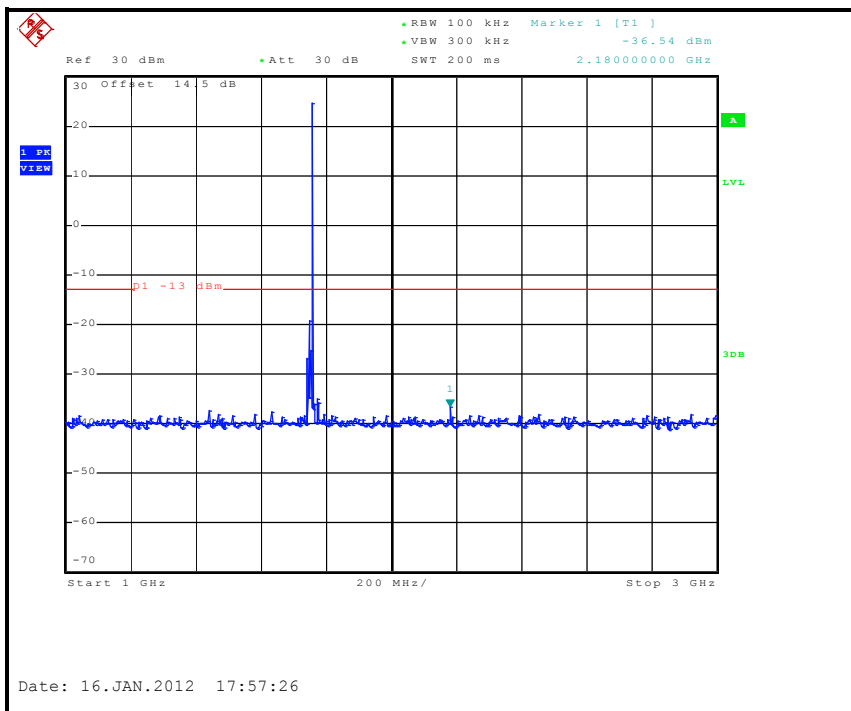



A D T

3GHz ~ 8GHz

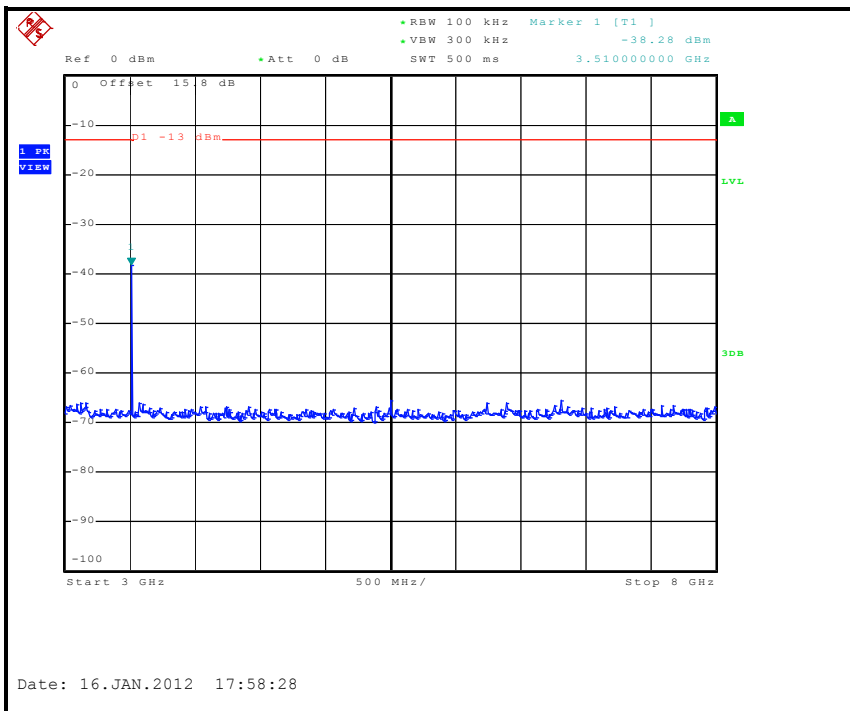

8GHz ~ 18GHz

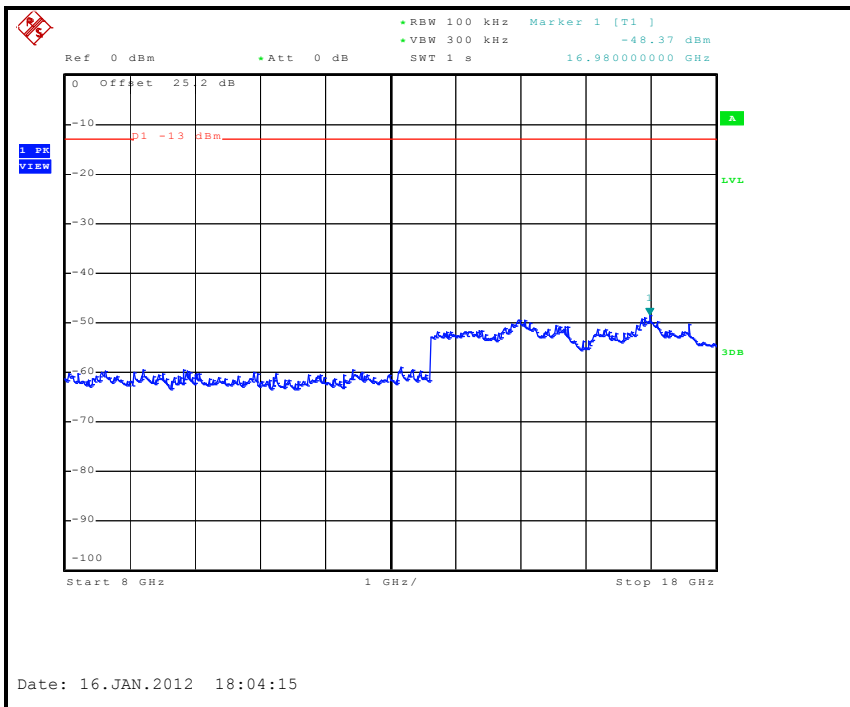

4.7 RADIATED EMISSION MEASUREMENT

4.7.1 LIMITS OF RADIATED EMISSION MEASUREMENT

The power of any emission outside a licensee's frequency block shall be attenuated below the transmitter power (P) by at least $43 + 10 \log_{10}(P)$ dB. The limit of emission equal to -13 dBm

So the limit of emission is the same absolute specified line.

LIMIT (dBm)	EQUIVALENT FIELD STRENGTH AT 3m (dBuV/m) (NOTE)
-13	82.22

NOTE: The following formula is used to convert the equipment radiated power to field strength.

$$E = [1000000 \sqrt{(30P)}] / 3 \text{ uV/m, where P is Watts.}$$

4.7.2 TEST INSTRUMENTS

DESCRIPTION & MANUFACTURER	MODEL NO.	SERIAL NO.	DATE OF CALIBRATION	DUE DATE OF CALIBRATION
Test Receiver ROHDE & SCHWARZ	ESCI	100744	Apr. 19, 2011	Apr. 18, 2012
Spectrum Analyzer ROHDE & SCHWARZ	FSP40	100269	Jan. 06, 2011	Jan. 05, 2012
BILOG Antenna SCHWARZBECK	VULB9168	9168-156	Apr. 12, 2011	Apr. 11, 2012
HORN Antenna SCHWARZBECK	BBHA 9120 D	9120D-563	Sep. 06, 2011	Sep. 05, 2012
HORN Antenna SCHWARZBECK	BBHA 9170	148	Jul. 20, 2011	Jul. 19, 2012
Preamplifier Agilent	8449B	3008A01911	Oct. 29, 2011	Oct. 28, 2012
Preamplifier Agilent	8447D	2944A10638	Oct. 29, 2011	Oct. 28, 2012
RF signal cable HUBER+SUHNNER	SUCOFLEX 104	295013/4 283403/4	Aug. 19, 2011	Aug. 18, 2012
RF signal cable Worken	8D-FB	Cable-HYCH9-01	Aug. 13, 2011	Aug. 12, 2012
Software	ADT_Radiated_ V7.6.15.9.2	NA	NA	NA
Antenna Tower EMCO	2070/2080	512.835.4684	NA	NA
Turn Table EMCO	2087-2.03	NA	NA	NA
Antenna Tower & Turn Table Controller EMCO	2090	NA	NA	NA

- NOTE:**
1. The calibration interval of the above test instruments is 12 months and the calibrations are traceable to NML/ROC and NIST/USA.
 2. The test was performed in HwaYa Chamber 9.
 3. The horn antenna and HP preamplifier (model: 8449B) are used only for the measurement of emission frequency above 1GHz if tested.
 4. The FCC Site Registration No. is 460141.
 5. The IC Site Registration No. is IC 7450F-4.

4.7.3 TEST PROCEDURES

- a. The EUT was placed on the top of a rotating table 0.8 meters above the ground. The table was rotated 360 degrees to determine the position of the highest radiation.
- b. The EUT was set 3 meters away from the receiving antenna, which was mounted on antenna tower and its position at 0.8 m above the ground.
- c. For each suspected emission, the EUT was arranged to its worst case and the rotatable table was turned from 0 degrees to 360 degrees to find the maximum reading and recorded the value.
- d. Repeat step a ~ c for horizontal polarization.

NOTE: The resolution bandwidth of spectrum analyzer is 1 MHz and the video bandwidth is 3 MHz.

4.7.4 DEVIATION FROM TEST STANDARD

No deviation

4.7.5 TEST SETUP

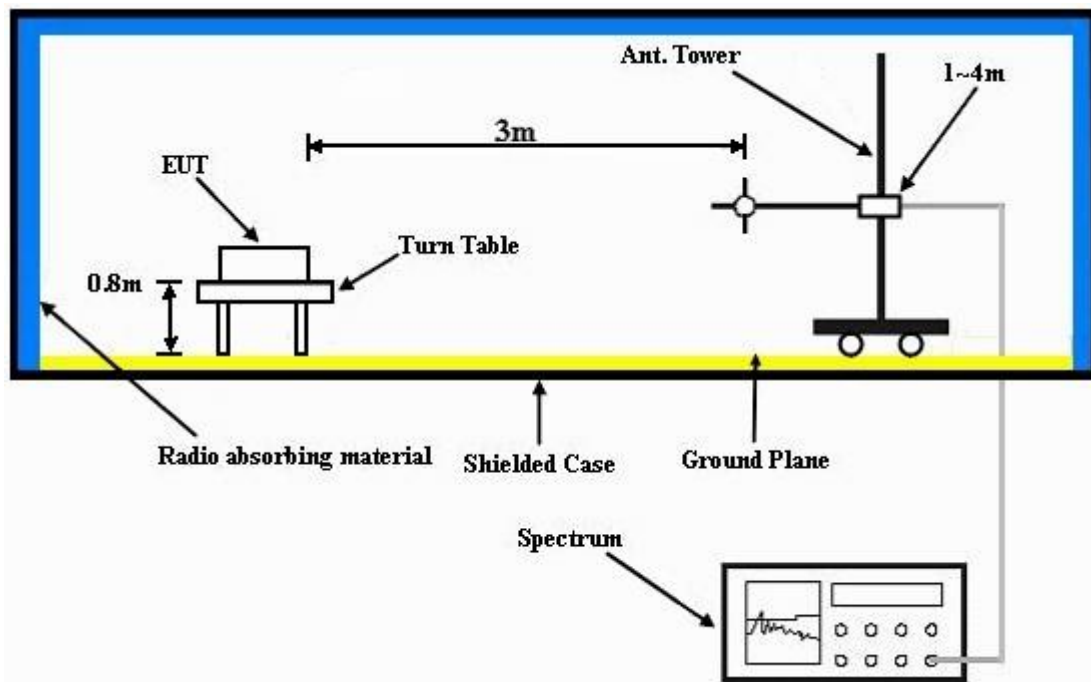

For the actual test configuration, please refer to the attached file (Test Setup Photo).

4.7.6 EUT OPERATING CONDITIONS

- a. The EUT makes a call to the communication simulator.
- b. The communication simulator station system controlled an EUT to export maximum output power under transmission mode and specific channel frequency.

4.7.7 TEST RESULTS

LTE Band 17

CHANNEL BANDWIDTH: 5MHz

MODE	Middle channel	Modulation	QPSK
RB / Offset	1 / 0	Polarization	Horizontal

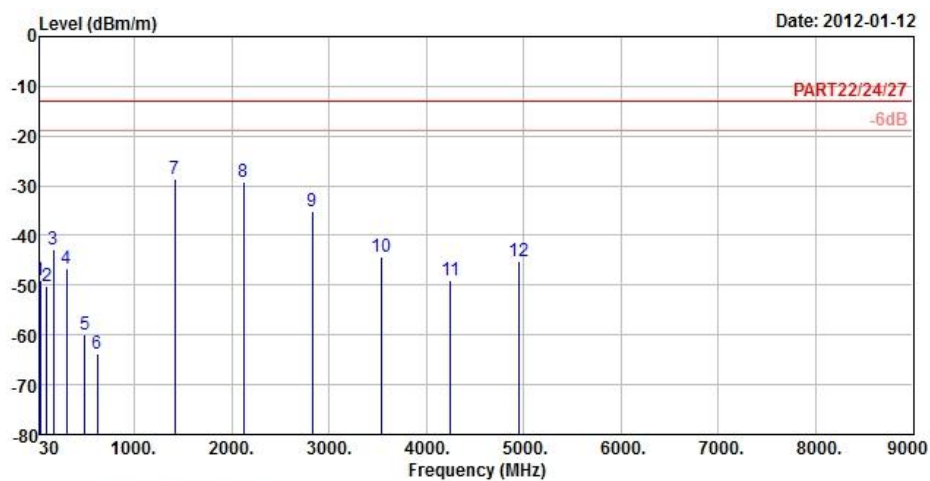

Site : 966 Chamber 2
 Condition: PART22/24/27 3m EIRP_RSE_1G~19G HORIZONTAL
 EUT : RJ83100
 Mode : LTE Band 17 (QPSK 1,0) CH23790 5M
 Plane : X
 Sample NO: C120110-004-004-005

	Freq	Level	Limit	Read	Over		
	MHz	dBm/m	dBm/m	dBm	dB	dB/m	Remark
1	32.16	-49.03	-13.00	-48.64	-36.03	-0.39	Peak
2	98.04	-50.11	-13.00	-39.67	-37.11	-10.44	Peak
3	169.05	-42.66	-13.00	-35.98	-29.66	-6.68	Peak
4	306.30	-46.62	-13.00	-40.29	-33.62	-6.33	Peak
5	487.60	-59.82	-13.00	-56.41	-46.82	-3.41	Peak
6	618.50	-63.84	-13.00	-63.82	-50.84	-0.02	Peak
7 pp	1415.70	-28.51	-13.00	-15.18	-15.51	-13.33	Peak
8	2123.55	-29.13	-13.00	-17.62	-16.13	-11.51	Peak
9	2831.40	-35.11	-13.00	-25.82	-22.11	-9.29	Peak
10	3539.25	-44.36	-13.00	-35.78	-31.36	-8.58	Peak
11	4247.10	-49.04	-13.00	-42.26	-36.04	-6.78	Peak
12	4954.95	-45.19	-13.00	-41.87	-32.19	-3.32	Peak



A D T

CHANNEL BANDWIDTH: 5MHz

MODE	Middle channel	Modulation	QPSK
RB / Offset	1 / 0	Polarization	Vertical

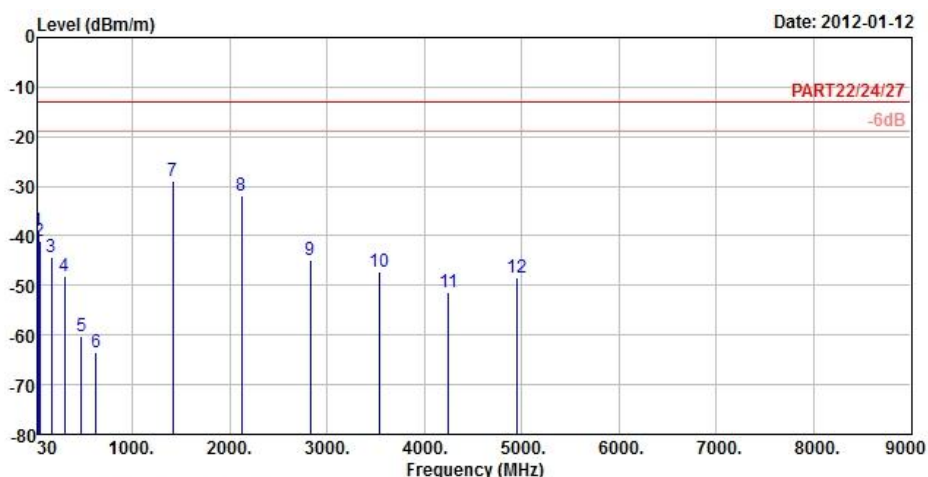

Site : 966 Chamber 2
 Condition: PART22/24/27 3m EIRP_RSE_1G~19G VERTICAL
 EUT : RJ83100
 Mode : LTE Band 17 (QPSK 1,0) CH23790 5M
 Plane : X
 Sample NO: C120110-004-004-005

	Freq	Level	Limit	Read	Over	
	MHz	dBm/m	dBm/m	dBm	dB	dB/m
1	33.24	-38.89	-13.00	-37.78	-25.89	-1.11 Peak
2	44.04	-41.13	-13.00	-39.87	-28.13	-1.26 Peak
3	167.16	-44.30	-13.00	-37.66	-31.30	-6.64 Peak
4	300.70	-48.25	-13.00	-41.88	-35.25	-6.37 Peak
5	476.40	-60.36	-13.00	-56.66	-47.36	-3.70 Peak
6	626.20	-63.49	-13.00	-63.61	-50.49	0.12 Peak
7 pp	1415.70	-28.91	-13.00	-15.58	-15.91	-13.33 Peak
8	2123.55	-32.02	-13.00	-20.51	-19.02	-11.51 Peak
9	2831.40	-45.00	-13.00	-35.71	-32.00	-9.29 Peak
10	3539.25	-47.09	-13.00	-38.51	-34.09	-8.58 Peak
11	4247.10	-51.36	-13.00	-44.58	-38.36	-6.78 Peak
12	4954.95	-48.29	-13.00	-44.97	-35.29	-3.32 Peak

CHANNEL BANDWIDTH: 5MHz

MODE	Middle channel	Modulation	QPSK
RB / Offset	25 / 0	Polarization	Horizontal

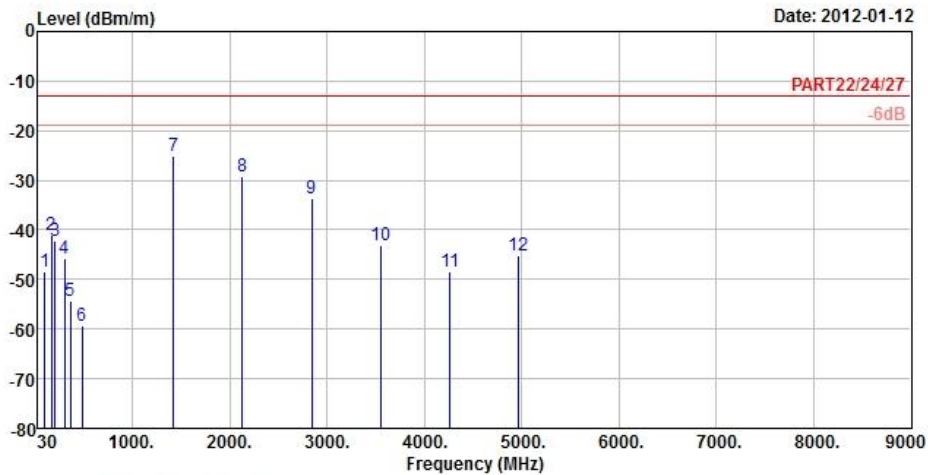

Site : 966 Chamber 2
 Condition: PART22/24/27 3m EIRP_RSE _1G~19G HORIZONTAL
 EUT : RJ83100
 Mode : LTE Band 17 (QPSK 25,0) CH23790 5M
 Plane : X
 Sample NO: C120110-004-004-005

	Freq	Level	Limit	Read	Over		
	MHz	dBm/m	dBm/m	dBm	dB	dB/m	Remark
1	99.93	-48.48	-13.00	-38.08	-35.48	-10.40	Peak
2	169.59	-41.01	-13.00	-34.31	-28.01	-6.70	Peak
3	208.74	-42.36	-13.00	-34.80	-29.36	-7.56	Peak
4	302.10	-45.69	-13.00	-39.33	-32.69	-6.36	Peak
5	361.60	-54.32	-13.00	-48.40	-41.32	-5.92	Peak
6	483.40	-59.33	-13.00	-55.80	-46.33	-3.53	Peak
7 pp	1420.00	-25.00	-13.00	-11.67	-12.00	-13.33	Peak
8	2130.00	-29.20	-13.00	-17.81	-16.20	-11.39	Peak
9	2840.00	-33.62	-13.00	-24.33	-20.62	-9.29	Peak
10	3550.00	-43.16	-13.00	-34.58	-30.16	-8.58	Peak
11	4260.00	-48.37	-13.00	-41.67	-35.37	-6.70	Peak
12	4970.00	-45.27	-13.00	-42.00	-32.27	-3.27	Peak



A D T

CHANNEL BANDWIDTH: 5MHz

MODE	Middle channel	Modulation	QPSK
RB / Offset	25 / 0	Polarization	Vertical

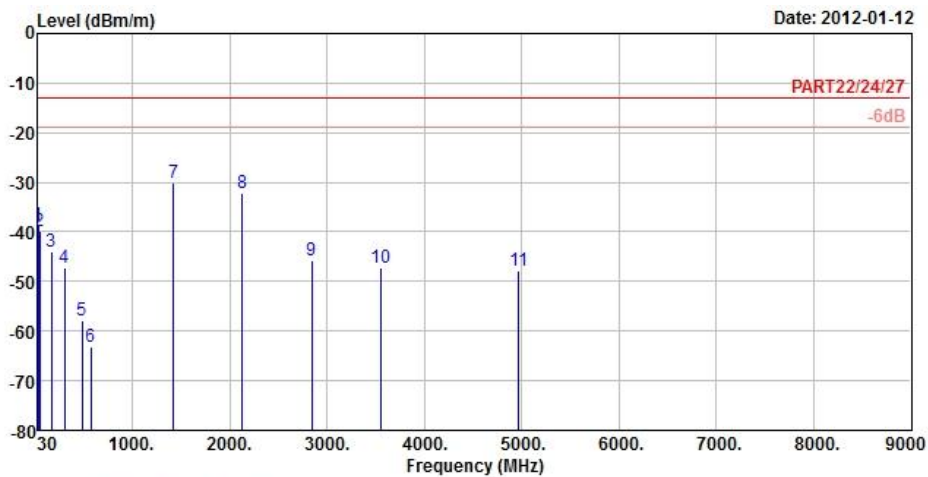

Site : 966 Chamber 2
 Condition: PART22/24/27 3m EIRP_RSE_1G~19G VERTICAL
 EUT : RJ83100
 Mode : LTE Band 17 (QPSK 25,0) CH23790 5M
 Plane : X
 Sample NO: C120110-004-004-005

	Freq	Level	Limit	Read	Over		
	MHz	dBm/m	Line	Level	Limit	Factor	Remark
			dBm/m	dBm	dB	dB/m	
1	32.97	-38.65	-13.00	-37.54	-25.65	-1.11	Peak
2	44.31	-39.93	-13.00	-38.74	-26.93	-1.19	Peak
3	167.16	-44.06	-13.00	-37.42	-31.06	-6.64	Peak
4	300.70	-47.36	-13.00	-40.99	-34.36	-6.37	Peak
5	482.00	-57.89	-13.00	-54.33	-44.89	-3.56	Peak
6	575.10	-63.14	-13.00	-62.10	-50.14	-1.04	Peak
7 pp	1420.00	-30.19	-13.00	-16.86	-17.19	-13.33	Peak
8	2130.00	-32.10	-13.00	-20.71	-19.10	-11.39	Peak
9	2840.00	-45.64	-13.00	-36.35	-32.64	-9.29	Peak
10	3550.00	-47.30	-13.00	-38.72	-34.30	-8.58	Peak
11	4970.00	-47.78	-13.00	-44.51	-34.78	-3.27	Peak



A D T

CHANNEL BANDWIDTH: 10MHz

MODE	Middle channel	Modulation	QPSK
RB / Offset	1 / 49	Polarization	Horizontal

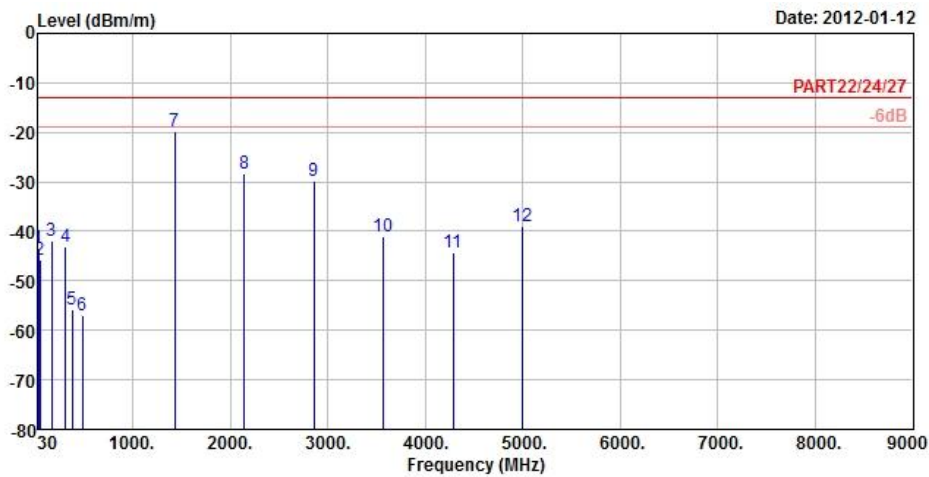

Site : 966 Chamber 2
 Condition: PART22/24/27 3m EIRP_RSE_1G~19G HORIZONTAL
 EUT : RJ83100
 Mode : LTE Band 17 (QPSK1,49) CH23790 10M
 Plane : X
 Sample NO: C120110-004-004-005

	Freq	Level	Limit	Read	Over		
	MHz	dBm/m	dBm/m	dBm	dB	dB/m	Remark
1	33.51	-43.42	-13.00	-41.58	-30.42	-1.84	Peak
2	44.04	-45.77	-13.00	-44.51	-32.77	-1.26	Peak
3	168.24	-41.84	-13.00	-35.16	-28.84	-6.68	Peak
4	307.00	-43.16	-13.00	-36.84	-30.16	-6.32	Peak
5	374.90	-55.67	-13.00	-49.85	-42.67	-5.82	Peak
6	485.50	-56.97	-13.00	-53.51	-43.97	-3.46	Peak
7 pp	1429.00	-19.84	-13.00	-6.49	-6.84	-13.35	Peak
8	2143.00	-28.37	-13.00	-17.06	-15.37	-11.31	Peak
9	2857.00	-29.89	-13.00	-20.56	-16.89	-9.33	Peak
10	3574.00	-41.02	-13.00	-32.49	-28.02	-8.53	Peak
11	4285.00	-44.34	-13.00	-37.79	-31.34	-6.55	Peak
12	5000.00	-39.02	-13.00	-36.33	-26.02	-2.69	Peak

CHANNEL BANDWIDTH: 10MHz

MODE	Middle channel	Modulation	QPSK
RB / Offset	1 / 49	Polarization	Vertical

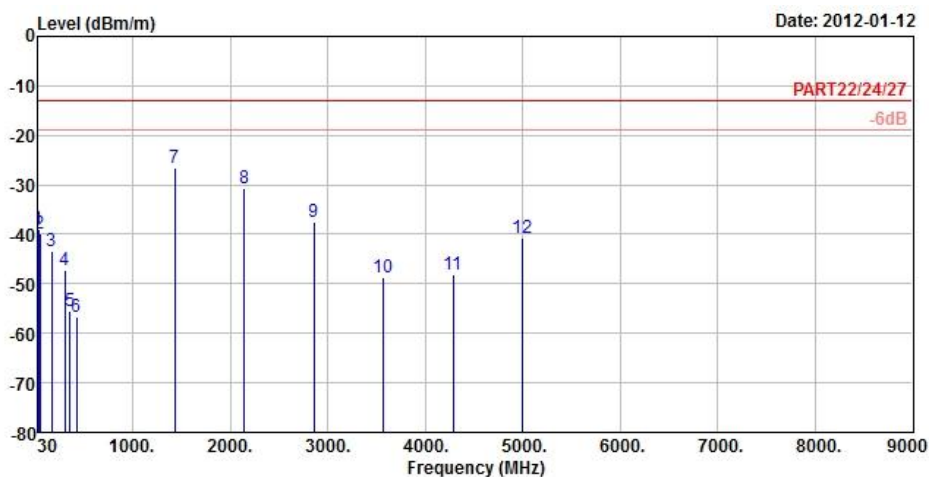

Site : 966 Chamber 2
 Condition: PART22/24/27 3m EIRP_RSE_1G~19G VERTICAL
 EUT : RJ83100
 Mode : LTE Band 17 (QPSK1,49) CH23790 10M
 Plane : X
 Sample NO: C120110-004-004-005

	Freq	Level	Limit	Read	Over		
	MHz	dBm/m	dBm/m	dBm	dB	dB/m	Remark
1	32.97	-38.86	-13.00	-37.75	-25.86	-1.11	Peak
2	44.31	-39.90	-13.00	-38.71	-26.90	-1.19	Peak
3	168.51	-43.43	-13.00	-36.75	-30.43	-6.68	Peak
4	301.40	-47.27	-13.00	-40.90	-34.27	-6.37	Peak
5	352.50	-55.62	-13.00	-49.63	-42.62	-5.99	Peak
6	420.40	-56.75	-13.00	-51.62	-43.75	-5.13	Peak
7 pp	1429.00	-26.51	-13.00	-13.16	-13.51	-13.35	Peak
8	2143.00	-30.73	-13.00	-19.42	-17.73	-11.31	Peak
9	2857.00	-37.59	-13.00	-28.26	-24.59	-9.33	Peak
10	3574.00	-48.61	-13.00	-40.08	-35.61	-8.53	Peak
11	4285.00	-48.24	-13.00	-41.69	-35.24	-6.55	Peak
12	5000.00	-40.70	-13.00	-38.01	-27.70	-2.69	Peak



A D T

CHANNEL BANDWIDTH: 10MHz

MODE	Middle channel	Modulation	QPSK
RB / Offset	50 / 0	Polarization	Horizontal

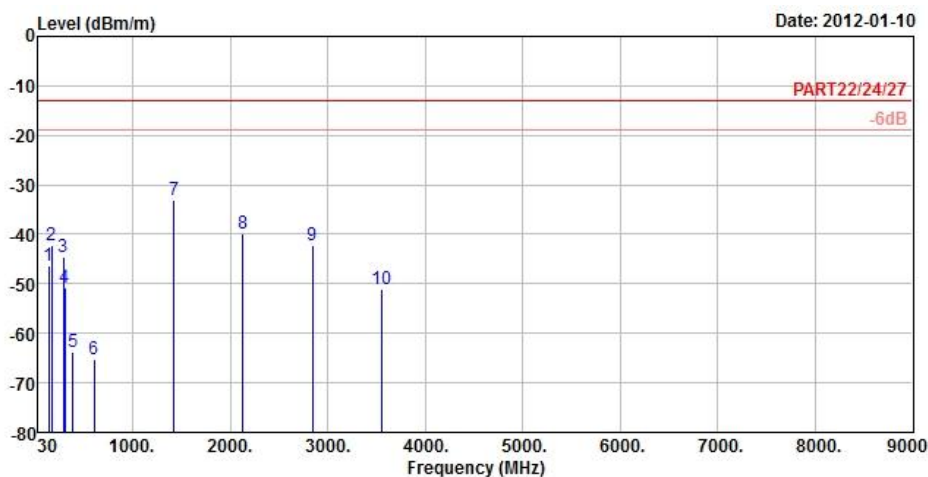

Site : 966 Chamber 2
 Condition: PART22/24/27 3m EIRP_RSE_1G~19G HORIZONTAL
 EUT : RJ83100
 Mode : LTE Band 17 (QPSK50,0) CH23790 10M
 Plane : X
 Sample NO: C120110-004-004-005

	Freq	Level	Limit	Read	Over		
	MHz	dBm/m	dBm/m	dBm	dB	dB/m	Remark
1	136.92	-46.28	-13.00	-39.83	-33.28	-6.45	Peak
2	168.24	-42.17	-13.00	-35.49	-29.17	-6.68	Peak
3	288.12	-44.53	-13.00	-38.31	-31.53	-6.22	Peak
4	304.20	-50.86	-13.00	-44.52	-37.86	-6.34	Peak
5	384.00	-63.72	-13.00	-57.97	-50.72	-5.75	Peak
6	601.00	-65.36	-13.00	-65.03	-52.36	-0.33	Peak
7 pp	1420.00	-32.97	-13.00	-19.64	-19.97	-13.33	Peak
8	2130.00	-39.96	-13.00	-28.57	-26.96	-11.39	Peak
9	2840.00	-42.12	-13.00	-32.83	-29.12	-9.29	Peak
10	3550.00	-51.04	-13.00	-42.46	-38.04	-8.58	Peak

CHANNEL BANDWIDTH: 10MHz

MODE	Middle channel	Modulation	QPSK
RB / Offset	50 / 0	Polarization	Vertical

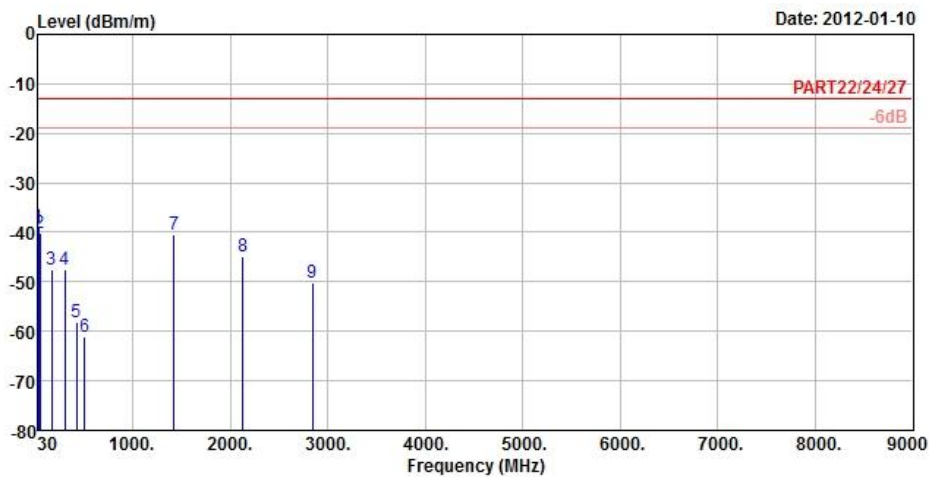

Site : 966 Chamber 2
 Condition: PART22/24/27 3m EIRP_RSE_1G~19G VERTICAL
 EUT : RJ83100
 Mode : LTE Band 17 (QPSK50,0) CH23790 10M
 Plane : X
 Sample NO: C120110-004-004-005

	Freq	Level	Limit	Read	Over		
	MHz	dBm/m	Line	Level	Limit	Factor	Remark
			dBm/m	dBm	dB	dB/m	
1	pp	33.24	-38.87	-13.00	-37.76	-25.87	-1.11 Peak
2		44.04	-40.13	-13.00	-38.87	-27.13	-1.26 Peak
3		167.16	-47.43	-13.00	-40.79	-34.43	-6.64 Peak
4		300.00	-47.43	-13.00	-41.05	-34.43	-6.38 Peak
5		425.30	-58.06	-13.00	-53.08	-45.06	-4.98 Peak
6		507.90	-61.19	-13.00	-58.31	-48.19	-2.88 Peak
7		1420.00	-40.53	-13.00	-27.20	-27.53	-13.33 Peak
8		2130.00	-44.92	-13.00	-33.53	-31.92	-11.39 Peak
9		2840.00	-50.33	-13.00	-41.04	-37.33	-9.29 Peak

CHANNEL BANDWIDTH: 5MHz

MODE	Middle channel	Modulation	16QAM
RB / Offset	1 / 0	Polarization	Horizontal

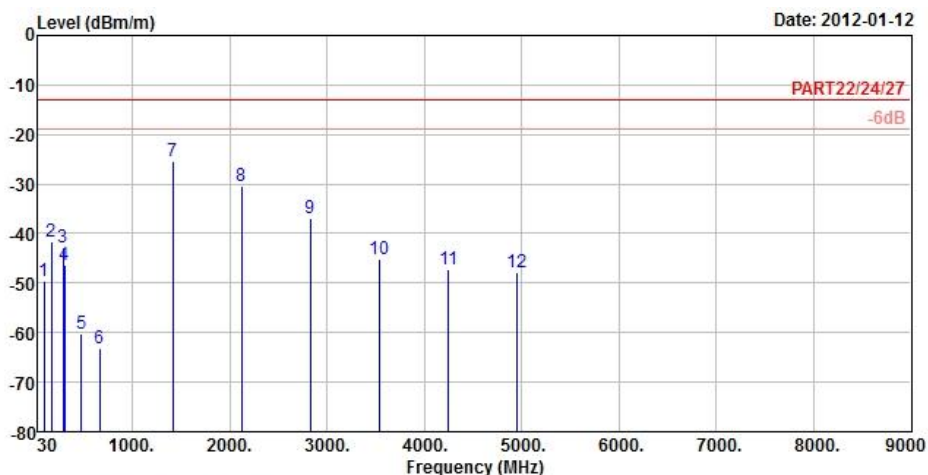

Site : 966 Chamber 2
 Condition: PART22/24/27 3m EIRP_RSE_1G~19G HORIZONTAL
 EUT : RJ83100
 Mode : LTE Band 17 (16QAM 1,0) CH23790 5M
 Plane : X
 Sample NO: C120110-004-004-005

	Freq	Level	Read Level	Limit Line	Over Limit	Factor	Remark
	MHz	dBm/m	dBm	dBm/m	dB	dB/m	
1	96.15	-49.61	-39.14	-13.00	-36.61	-10.47	Peak
2	169.05	-41.56	-34.88	-13.00	-28.56	-6.68	Peak
3	287.85	-42.87	-36.65	-13.00	-29.87	-6.22	Peak
4	301.40	-46.46	-40.09	-13.00	-33.46	-6.37	Peak
5	477.10	-60.13	-56.45	-13.00	-47.13	-3.68	Peak
6	662.60	-63.22	-63.99	-13.00	-50.22	0.77	Peak
7 pp	1415.70	-25.42	-12.09	-13.00	-12.42	-13.33	Peak
8	2123.55	-30.31	-18.80	-13.00	-17.31	-11.51	Peak
9	2831.40	-36.97	-27.68	-13.00	-23.97	-9.29	Peak
10	3539.28	-45.22	-36.64	-13.00	-32.22	-8.58	Peak
11	4247.10	-47.26	-40.48	-13.00	-34.26	-6.78	Peak
12	4954.95	-47.97	-44.65	-13.00	-34.97	-3.32	Peak

CHANNEL BANDWIDTH: 5MHz

MODE	Middle channel	Modulation	16QAM
RB / Offset	1 / 0	Polarization	Vertical

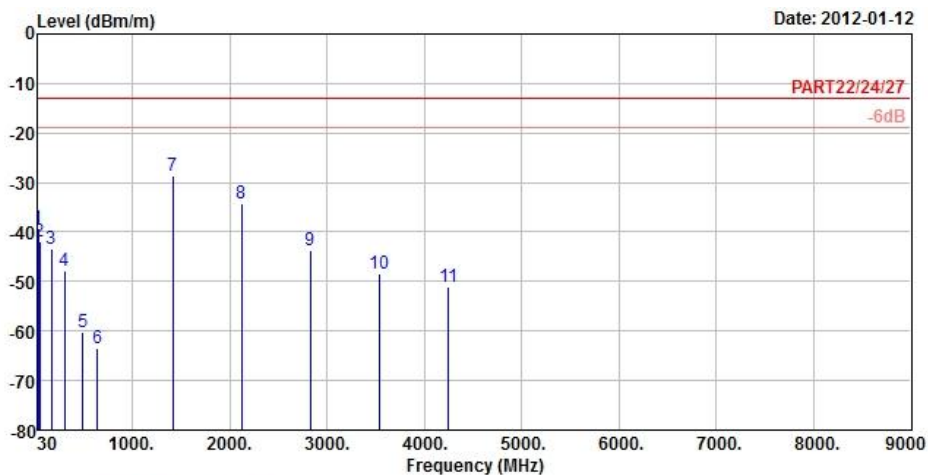

Site : 966 Chamber 2
 Condition: PART22/24/27 3m EIRP_RSE_1G~19G VERTICAL
 EUT : RJ83100
 Mode : LTE Band 17 (16QAM 1,0) CH23790 5M
 Plane : X
 Sample NO: C120110-004-004-005

	Freq	Level	Read Level	Limit	Over	Factor	Remark
	MHz	dBm/m	dBm	dBm/m	dB	dB/m	
1	33.51	-39.31	-37.47	-13.00	-26.31	-1.84	Peak
2	44.04	-41.83	-40.57	-13.00	-28.83	-1.26	Peak
3	167.43	-43.45	-36.79	-13.00	-30.45	-6.66	Peak
4	300.00	-47.71	-41.33	-13.00	-34.71	-6.38	Peak
5	488.30	-60.25	-56.84	-13.00	-47.25	-3.41	Peak
6	638.10	-63.41	-63.74	-13.00	-50.41	0.33	Peak
7 pp	1415.70	-28.54	-15.21	-13.00	-15.54	-13.33	Peak
8	2123.55	-34.21	-22.70	-13.00	-21.21	-11.51	Peak
9	2831.40	-43.61	-34.32	-13.00	-30.61	-9.29	Peak
10	3539.25	-48.27	-39.69	-13.00	-35.27	-8.58	Peak
11	4247.10	-51.00	-44.22	-13.00	-38.00	-6.78	Peak

CHANNEL BANDWIDTH: 5MHz

MODE	Middle channel	Modulation	16QAM
RB / Offset	25 / 0	Polarization	Horizontal

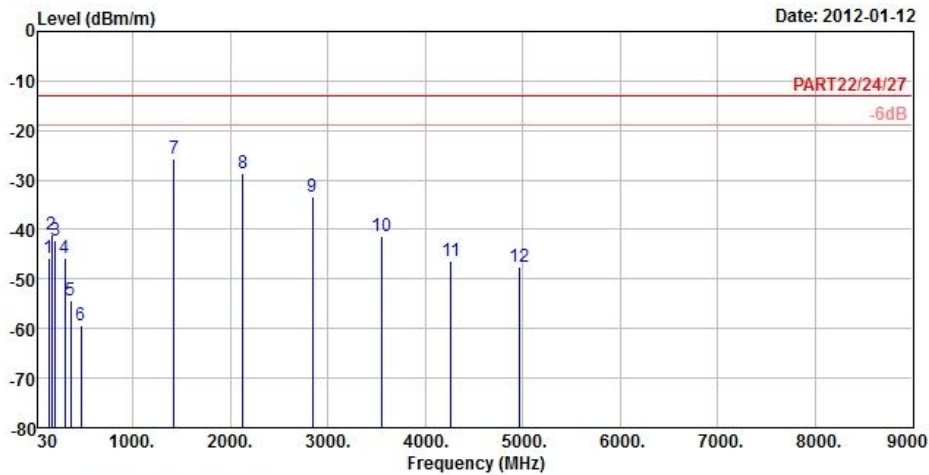

Site : 966 Chamber 2
 Condition: PART22/24/27 3m EIRP_RSE _1G~19G HORIZONTAL
 EUT : RJ83100
 Mode : LTE Band 17 (16QAM 25,0) CH23790 5M
 Plane : X
 Sample NO: C120110-004-004-005

	Freq	Level	Limit	Read	Over		
	MHz	dBm/m	dBm/m	dBm	dB	dB/m	Remark
1	140.16	-45.79	-13.00	-40.06	-32.79	-5.73	Peak
2	169.59	-41.01	-13.00	-34.31	-28.01	-6.70	Peak
3	208.74	-42.36	-13.00	-34.80	-29.36	-7.56	Peak
4	302.10	-45.69	-13.00	-39.33	-32.69	-6.36	Peak
5	361.60	-54.32	-13.00	-48.40	-41.32	-5.92	Peak
6	465.90	-59.27	-13.00	-55.30	-46.27	-3.97	Peak
7 pp	1420.00	-25.54	-13.00	-12.21	-12.54	-13.33	Peak
8	2130.00	-28.68	-13.00	-17.29	-15.68	-11.39	Peak
9	2840.00	-33.42	-13.00	-24.13	-20.42	-9.29	Peak
10	3550.00	-41.33	-13.00	-32.75	-28.33	-8.58	Peak
11	4260.00	-46.42	-13.00	-39.72	-33.42	-6.70	Peak
12	4970.00	-47.52	-13.00	-44.25	-34.52	-3.27	Peak



A D T

CHANNEL BANDWIDTH: 5MHz

MODE	Middle channel	Modulation	16QAM
RB / Offset	25 / 0	Polarization	Vertical

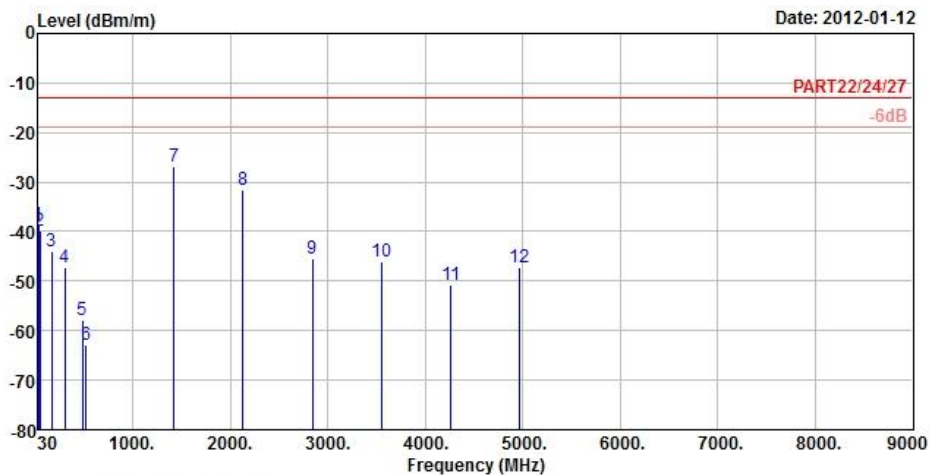

Site : 966 Chamber 2
 Condition: PART22/24/27 3m EIRP_RSE_1G~19G VERTICAL
 EUT : RJ83100
 Mode : LTE Band 17 (16QAM 25,0) CH23790 5M
 Plane : X
 Sample NO: C120110-004-004-005

	Freq	Level	Limit	Read	Over		
	MHz	dBm/m	dBm/m	dBm	dB	dB/m	Remark
1	32.97	-38.65	-13.00	-37.54	-25.65	-1.11	Peak
2	44.31	-39.93	-13.00	-38.74	-26.93	-1.19	Peak
3	167.16	-44.06	-13.00	-37.42	-31.06	-6.64	Peak
4	300.70	-47.36	-13.00	-40.99	-34.36	-6.37	Peak
5	482.00	-57.89	-13.00	-54.33	-44.89	-3.56	Peak
6	520.50	-62.84	-13.00	-60.31	-49.84	-2.53	Peak
7 pp	1420.00	-27.00	-13.00	-13.67	-14.00	-13.33	Peak
8	2130.00	-31.69	-13.00	-20.30	-18.69	-11.39	Peak
9	2840.00	-45.42	-13.00	-36.13	-32.42	-9.29	Peak
10	3550.00	-46.19	-13.00	-37.61	-33.19	-8.58	Peak
11	4260.00	-50.84	-13.00	-44.14	-37.84	-6.70	Peak
12	4970.00	-47.18	-13.00	-43.91	-34.18	-3.27	Peak



A D T

CHANNEL BANDWIDTH: 10MHz

MODE	Middle channel	Modulation	16QAM
RB / Offset	1 / 49	Polarization	Horizontal

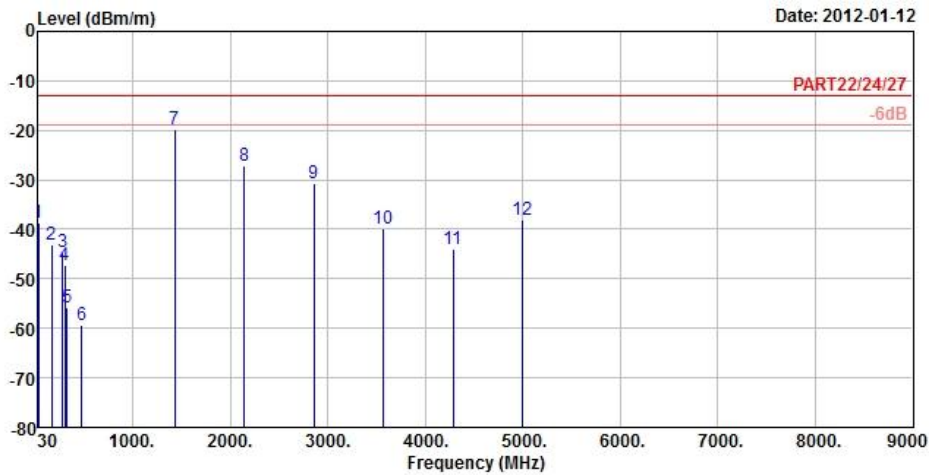

Site : 966 Chamber 2
 Condition: PART22/24/27 3m EIRP_RSE_1G~19G HORIZONTAL
 EUT : RJ83100
 Mode : LTE Band 17 (16QAM 1,49) CH23790 10M
 Plane : X
 Sample NO: C120110-004-004-005

	Freq	Level	Limit	Read	Over		
	MHz	dBm/m	dBm/m	dBm	dB	Factor	Remark
1	33.24	-38.82	-13.00	-37.71	-25.82	-1.11	Peak
2	167.70	-43.12	-13.00	-36.46	-30.12	-6.66	Peak
3	283.80	-44.62	-13.00	-38.46	-31.62	-6.16	Peak
4	300.00	-47.37	-13.00	-40.99	-34.37	-6.38	Peak
5	327.30	-55.88	-13.00	-49.70	-42.88	-6.18	Peak
6	475.70	-59.42	-13.00	-55.69	-46.42	-3.73	Peak
7 pp	1428.80	-19.83	-13.00	-6.48	-6.83	-13.35	Peak
8	2143.20	-27.19	-13.00	-15.88	-14.19	-11.31	Peak
9	2857.60	-30.61	-13.00	-21.28	-17.61	-9.33	Peak
10	3572.00	-39.78	-13.00	-31.25	-26.78	-8.53	Peak
11	4286.40	-44.00	-13.00	-37.60	-31.00	-6.40	Peak
12	5000.80	-38.02	-13.00	-35.33	-25.02	-2.69	Peak



A D T

CHANNEL BANDWIDTH: 10MHz

MODE	Middle channel	Modulation	16QAM
RB / Offset	1 / 49	Polarization	Vertical

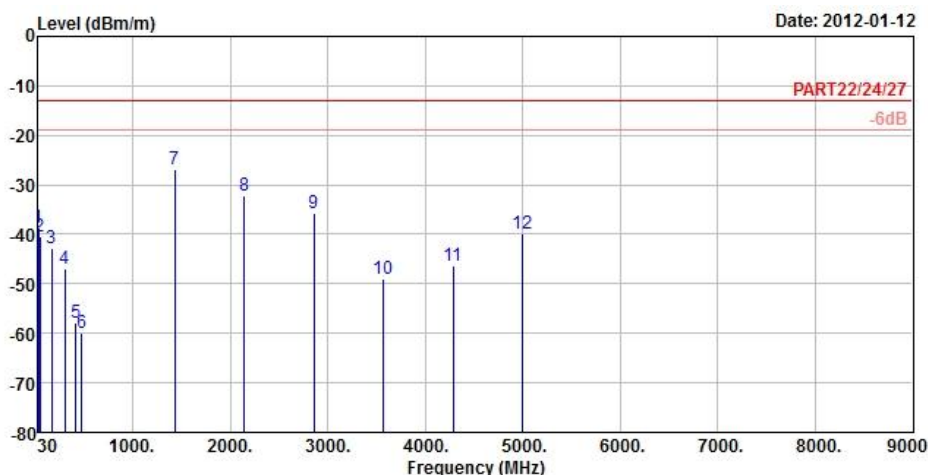

Site : 966 Chamber 2
 Condition: PART22/24/27 3m EIRP_RSE_1G~19G VERTICAL
 EUT : RJ83100
 Mode : LTE Band 17 (16QAM 1,49) CH23790 10M
 Plane : X
 Sample NO: C120110-004-004-005

	Freq	Level	Limit	Read	Over		
	MHz	dBm/m	Line	Level	Limit	Factor	Remark
			dBm/m	dBm	dB	dB/m	
1	33.24	-38.76	-13.00	-37.65	-25.76	-1.11	Peak
2	43.77	-40.32	-13.00	-39.06	-27.32	-1.26	Peak
3	167.97	-42.89	-13.00	-36.23	-29.89	-6.66	Peak
4	300.70	-47.02	-13.00	-40.65	-34.02	-6.37	Peak
5	419.00	-57.84	-13.00	-52.69	-44.84	-5.15	Peak
6	479.20	-59.91	-13.00	-56.28	-46.91	-3.63	Peak
7 pp	1428.80	-26.81	-13.00	-13.46	-13.81	-13.35	Peak
8	2143.20	-32.26	-13.00	-20.95	-19.26	-11.31	Peak
9	2857.60	-35.60	-13.00	-26.27	-22.60	-9.33	Peak
10	3572.00	-49.09	-13.00	-40.56	-36.09	-8.53	Peak
11	4286.40	-46.23	-13.00	-39.83	-33.23	-6.40	Peak
12	5000.80	-39.78	-13.00	-37.09	-26.78	-2.69	Peak

CHANNEL BANDWIDTH: 10MHz

MODE	Middle channel	Modulation	16QAM
RB / Offset	50 / 0	Polarization	Horizontal

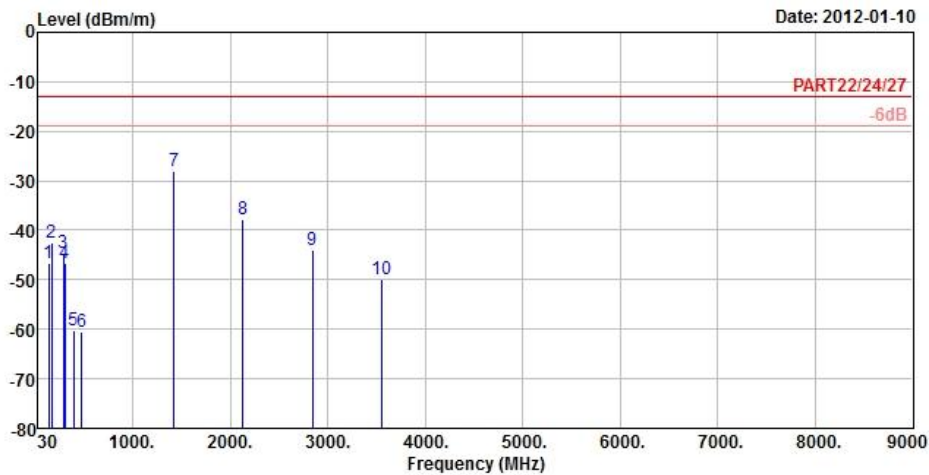

Site : 966 Chamber 2
 Condition: PART22/24/27 3m EIRP_RSE_1G~19G HORIZONTAL
 EUT : RJ83100
 Mode : LTE Band 17 (16QAM 50,0) CH23790 10M
 Plane : X
 Sample NO: C120110-004-004-005

	Freq	Level	Limit	Read	Over	Factor	Remark
	MHz	dBm/m	dBm/m	dBm	dB	dB/m	
1	137.46	-46.62	-13.00	-40.43	-33.62	-6.19	Peak
2	168.24	-42.58	-13.00	-35.90	-29.58	-6.68	Peak
3	289.20	-44.50	-13.00	-38.27	-31.50	-6.23	Peak
4	300.70	-46.65	-13.00	-40.28	-33.65	-6.37	Peak
5	392.40	-60.21	-13.00	-54.52	-47.21	-5.69	Peak
6	477.10	-60.40	-13.00	-56.72	-47.40	-3.68	Peak
7 pp	1420.00	-28.02	-13.00	-14.69	-15.02	-13.33	Peak
8	2130.00	-37.73	-13.00	-26.34	-24.73	-11.39	Peak
9	2840.00	-44.04	-13.00	-34.75	-31.04	-9.29	Peak
10	3550.00	-50.03	-13.00	-41.45	-37.03	-8.58	Peak



A D T

CHANNEL BANDWIDTH: 10MHz

MODE	Middle channel	Modulation	16QAM
RB / Offset	50 / 0	Polarization	Vertical

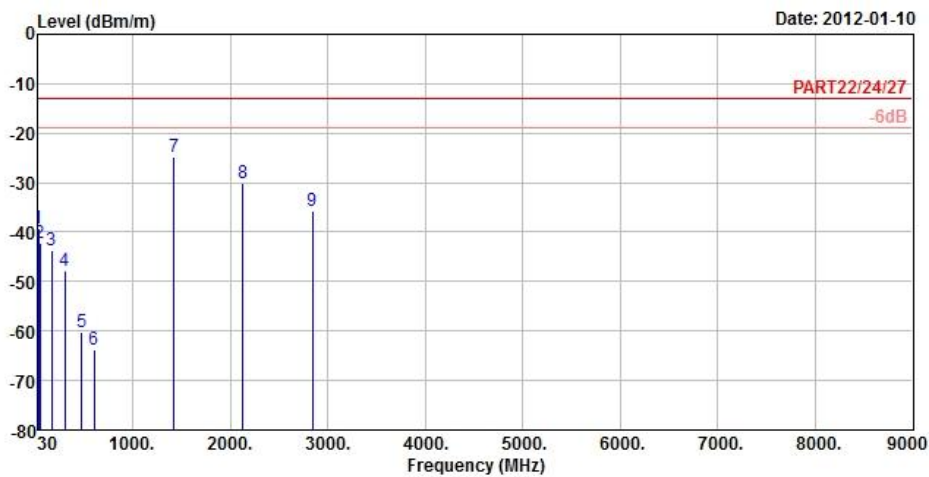

Site : 966 Chamber 2
 Condition: PART22/24/27 3m EIRP_RSE_1G~19G VERTICAL
 EUT : RJ83100
 Mode : LTE Band 17 (16QAM 50,0) CH23790 10M
 Plane : X
 Sample NO: C120110-004-004-005

	Freq	Level	Limit	Read	Over		
	MHz	dBm/m	dBm/m	dBm	dB	dB/m	Remark
1	32.97	-39.25	-13.00	-38.14	-26.25	-1.11	Peak
2	44.31	-42.34	-13.00	-41.15	-29.34	-1.19	Peak
3	167.70	-43.65	-13.00	-36.99	-30.65	-6.66	Peak
4	300.00	-47.88	-13.00	-41.50	-34.88	-6.38	Peak
5	476.40	-60.18	-13.00	-56.48	-47.18	-3.70	Peak
6	603.10	-63.71	-13.00	-63.41	-50.71	-0.30	Peak
7 pp	1420.00	-24.93	-13.00	-11.60	-11.93	-13.33	Peak
8	2130.00	-30.22	-13.00	-18.83	-17.22	-11.39	Peak
9	2840.00	-35.77	-13.00	-26.48	-22.77	-9.29	Peak

LTE Band 4

CHANNEL BANDWIDTH: 5MHz

MODE	Middle channel	Modulation	QPSK
RB / Offset	1 / 0	Polarization	Horizontal

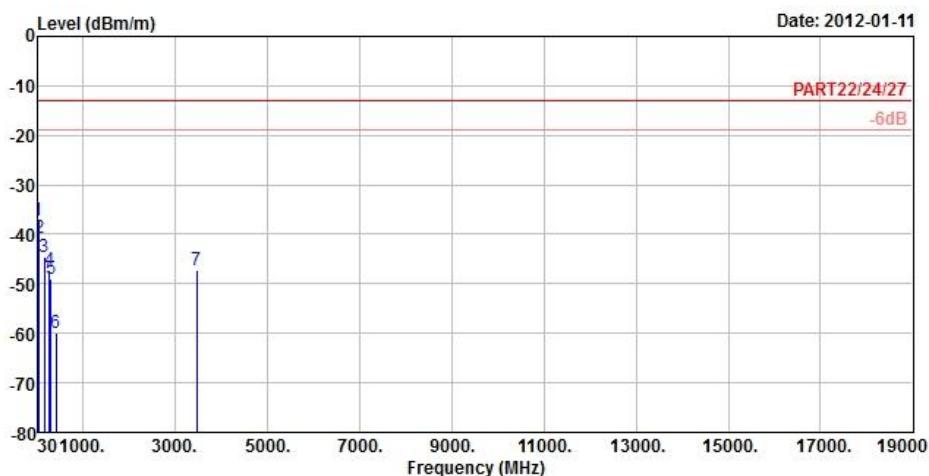

Site : 966 Chamber 2
 Condition: PART22/24/27 3m EIRP_RSE_1G~19G HORIZONTAL
 EUT : RJ83100
 Mode : LTE Band 4 (QPSK 1,0) CH20175 5M
 Plane : X
 Sample NO: C120110-004-004-005

	Freq	Level	Limit	Read	Over		
	MHz	dBm/m	Line	Level	Limit	Factor	Remark
			dBm/m	dBm	dB	dB/m	
1	pp	30.00	-37.15	-13.00	-38.22	-24.15	1.07 Peak
2		42.96	-40.73	-13.00	-39.40	-27.73	-1.33 Peak
3		165.27	-44.44	-13.00	-37.84	-31.44	-6.60 Peak
4		275.43	-47.25	-13.00	-41.21	-34.25	-6.04 Peak
5		300.70	-49.00	-13.00	-42.63	-36.00	-6.37 Peak
6		414.80	-59.85	-13.00	-54.60	-46.85	-5.25 Peak
7		3460.68	-47.25	-13.00	-38.33	-34.25	-8.92 Peak



A D T

CHANNEL BANDWIDTH: 5MHz

MODE	Middle channel	Modulation	QPSK
RB / Offset	1 / 0	Polarization	Vertical

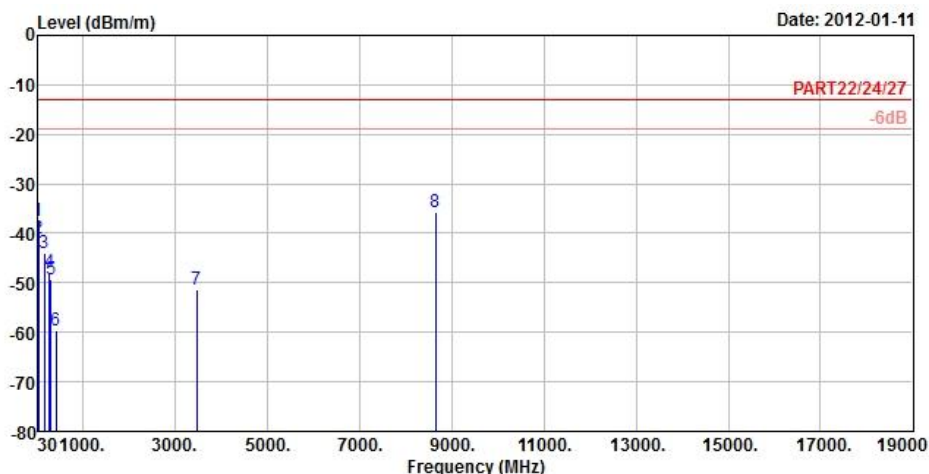

Site : 966 Chamber 2
 Condition: PART22/24/27 3m EIRP_RSE_1G~19G VERTICAL
 EUT : RJ83100
 Mode : LTE Band 4 (QPSK 1,0) CH20175 5M
 Plane : X
 Sample NO: C120110-004-004-005

	Freq	Level	Limit	Read	Over		
	MHz	dBm/m	dBm/m	dBm	dB	dB/m	Remark
1	30.00	-37.35	-13.00	-38.42	-24.35	1.07	Peak
2	42.69	-40.96	-13.00	-39.63	-27.96	-1.33	Peak
3	165.54	-44.07	-13.00	-37.45	-31.07	-6.62	Peak
4	269.76	-47.77	-13.00	-41.82	-34.77	-5.95	Peak
5	300.00	-49.44	-13.00	-43.06	-36.44	-6.38	Peak
6	414.10	-59.74	-13.00	-54.47	-46.74	-5.27	Peak
7	3460.68	-51.24	-13.00	-42.32	-38.24	-8.92	Peak
8 pp	8651.70	-35.68	-13.00	-41.59	-22.68	5.91	Peak

CHANNEL BANDWIDTH: 5MHz

MODE	Middle channel	Modulation	QPSK
RB / Offset	25 / 0	Polarization	Horizontal

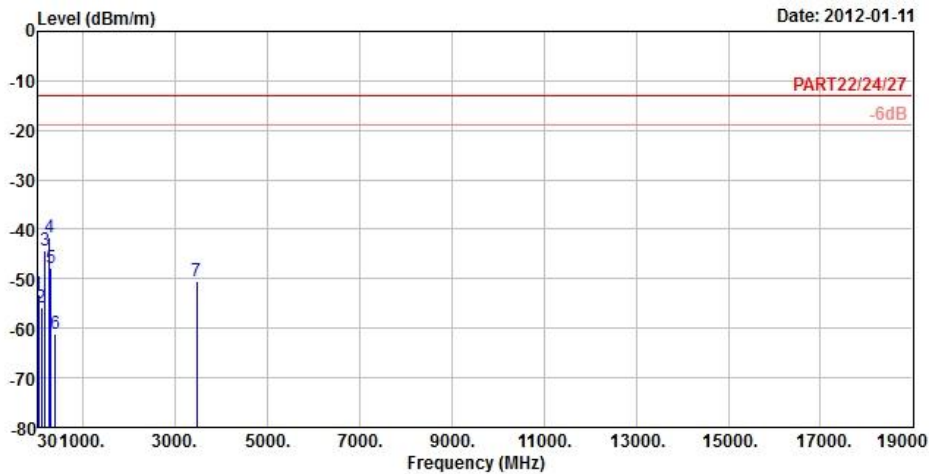

Site : 966 Chamber 2
 Condition: PART22/24/27 3m EIRP_RSE_1G~19G HORIZONTAL
 EUT : RJ83100
 Mode : LTE Band 4 (QPSK 25,0) CH19975 5M
 Plane : X
 Sample NO: C120110-004-004-005

	Freq	Level	Limit	Read	Over	
	MHz	dBm/m	dBm/m	dBm	dB	dB/m
1	33.51	-53.21	-13.00	-51.37	-40.21	-1.84 Peak
2	94.80	-55.92	-13.00	-45.43	-42.92	-10.49 Peak
3	170.67	-44.32	-13.00	-37.60	-31.32	-6.72 Peak
4 pp	268.68	-41.52	-13.00	-35.58	-28.52	-5.94 Peak
5	301.40	-47.78	-13.00	-41.41	-34.78	-6.37 Peak
6	397.30	-60.98	-13.00	-55.33	-47.98	-5.65 Peak
7	3465.00	-50.58	-13.00	-41.66	-37.58	-8.92 Peak



A D T

CHANNEL BANDWIDTH: 5MHz

MODE	Middle channel	Modulation	QPSK
RB / Offset	25 / 0	Polarization	Vertical

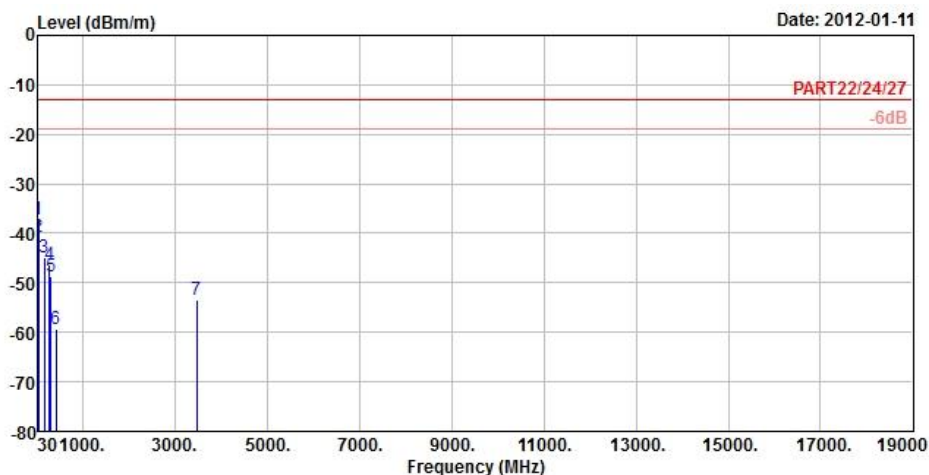

Site : 966 Chamber 2
 Condition: PART22/24/27 3m EIRP_RSE_1G~19G VERTICAL
 EUT : RJ83100
 Mode : LTE Band 4 (QPSK 25,0) CH19975 5M
 Plane : X
 Sample NO: C120110-004-004-005

	Freq	Level	Limit	Read	Over		
	MHz	dBm/m	dBm/m	dBm	dB	dB/m	
1	pp	30.00	-37.08	-13.00	-38.15	-24.08	1.07 Peak
2		41.88	-40.60	-13.00	-39.21	-27.60	-1.39 Peak
3		166.62	-44.91	-13.00	-38.27	-31.91	-6.64 Peak
4		269.49	-46.36	-13.00	-40.41	-33.36	-5.95 Peak
5		300.00	-48.86	-13.00	-42.48	-35.86	-6.38 Peak
6		410.60	-59.43	-13.00	-54.06	-46.43	-5.37 Peak
7		3465.00	-53.30	-13.00	-44.38	-40.30	-8.92 Peak



A D T

CHANNEL BANDWIDTH: 10MHz

MODE	Middle channel	Modulation	QPSK
RB / Offset	1 / 0	Polarization	Horizontal

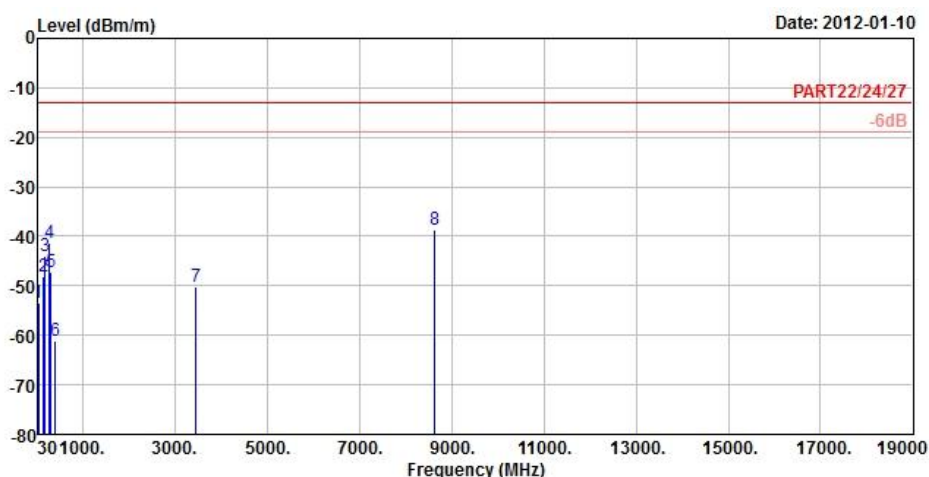

Site : 966 Chamber 2
 Condition: PART22/24/27 3m EIRP_RSE_1G~19G HORIZONTAL
 EUT : RJ83100
 Mode : LTE Band 4 (QPSK1,0) CH20175 10M
 Plane : Y
 Sample NO: C120110-004-004-005

	Freq	Level	Limit	Read	Over		
	MHz	dBm/m	dBm/m	dBm	dB	dB/m	Remark
1	33.24	-53.44	-13.00	-52.33	-40.44	-1.11	Peak
2	143.40	-48.06	-13.00	-42.14	-35.06	-5.92	Peak
3	170.40	-43.96	-13.00	-37.24	-30.96	-6.72	Peak
4	268.95	-41.39	-13.00	-35.45	-28.39	-5.94	Peak
5	300.70	-47.19	-13.00	-40.82	-34.19	-6.37	Peak
6	396.60	-61.16	-13.00	-55.50	-48.16	-5.66	Peak
7	3456.00	-50.14	-13.00	-41.20	-37.14	-8.94	Peak
8 pp	8640.00	-38.75	-13.00	-44.48	-25.75	5.73	Peak



A D T

CHANNEL BANDWIDTH: 10MHz

MODE	Middle channel	Modulation	QPSK
RB / Offset	1 / 0	Polarization	Vertical

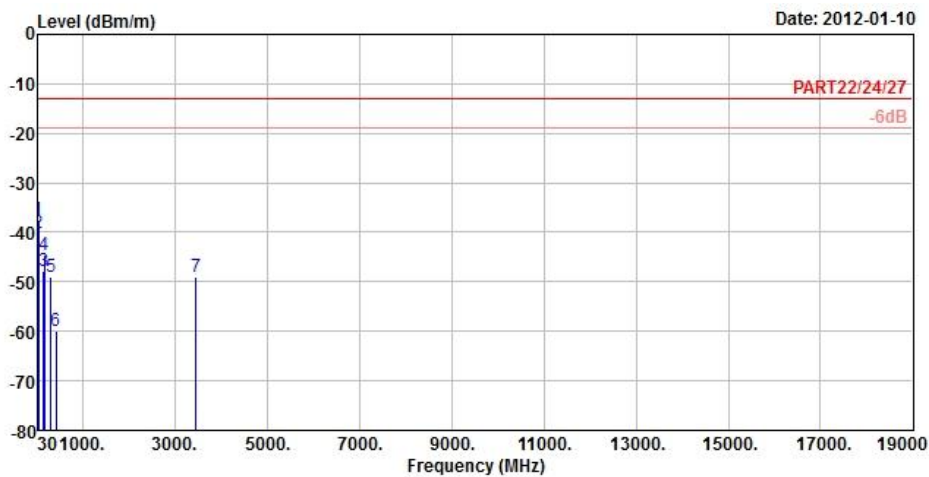

Site : 966 Chamber 2
 Condition: PART22/24/27 3m EIRP_RSE_1G~19G VERTICAL
 EUT : RJ83100
 Mode : LTE Band 4 (QPSK1,0) CH20175 10M
 Plane : Y
 Sample NO: C120110-004-004-005

	Freq	Level	Limit	Read	Over	Remark
	MHz	dBm/m	Line	Level	Limit	Factor
			dBm/m	dBm	dB	dB/m
1 pp	30.00	-37.35	-13.00	-38.42	-24.35	1.07 Peak
2	42.69	-40.11	-13.00	-38.78	-27.11	-1.33 Peak
3	144.75	-47.76	-13.00	-41.78	-34.76	-5.98 Peak
4	166.35	-44.63	-13.00	-37.99	-31.63	-6.64 Peak
5	300.70	-49.15	-13.00	-42.78	-36.15	-6.37 Peak
6	409.20	-60.04	-13.00	-54.65	-47.04	-5.39 Peak
7	3456.00	-48.97	-13.00	-40.03	-35.97	-8.94 Peak



A D T

CHANNEL BANDWIDTH: 10MHz

MODE	Middle channel	Modulation	QPSK
RB / Offset	50 / 0	Polarization	Horizontal

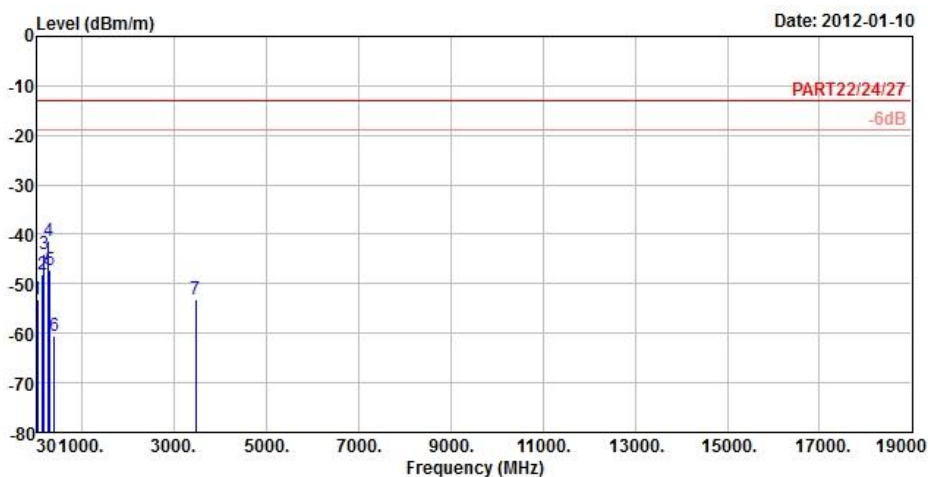

Site : 966 Chamber 2
 Condition: PART22/24/27 3m EIRP_RSE_1G~19G HORIZONTAL
 EUT : RJ83100
 Mode : LTE Band 4 (QPSK50,0) CH20175 10M
 Plane : X
 Sample NO: C120110-004-004-005

	Freq	Level	Limit	Read	Over		
	MHz	dBm/m	Line	Level	Limit	Factor	Remark
			dBm/m	dBm	dB	dB/m	
1	33.51	-53.27	-13.00	-51.43	-40.27	-1.84	Peak
2	143.67	-48.12	-13.00	-42.20	-35.12	-5.92	Peak
3	170.94	-43.93	-13.00	-37.21	-30.93	-6.72	Peak
4 pp	269.76	-41.39	-13.00	-35.44	-28.39	-5.95	Peak
5	300.70	-47.13	-13.00	-40.76	-34.13	-6.37	Peak
6	407.80	-60.66	-13.00	-55.22	-47.66	-5.44	Peak
7	3465.00	-53.22	-13.00	-44.30	-40.22	-8.92	Peak



A D T

CHANNEL BANDWIDTH: 10MHz

MODE	Middle channel	Modulation	QPSK
RB / Offset	50 / 0	Polarization	Vertical

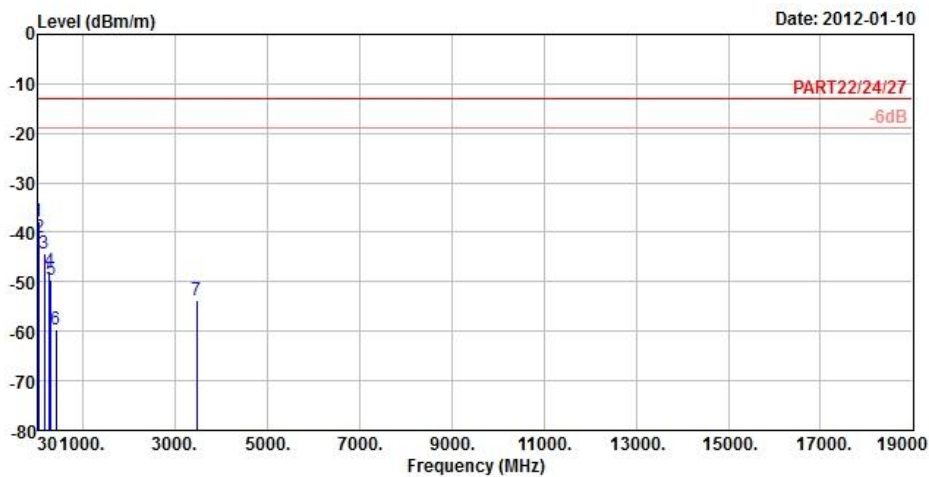

Site : 966 Chamber 2
 Condition: PART22/24/27 3m EIRP_RSE_1G~19G VERTICAL
 EUT : RJ83100
 Mode : LTE Band 4 (QPSK50,0) CH20175 10M
 Plane : X
 Sample NO: C120110-004-004-005

	Freq	Level	Limit	Read	Over	
	MHz	dBm/m	Line	Level	Limit	Factor Remark
			dBm/m	dBm	dB	dB/m
1	pp	30.27	-37.79	-13.00	-38.86	-24.79 1.07 Peak
2		42.96	-40.93	-13.00	-39.60	-27.93 -1.33 Peak
3		166.62	-44.32	-13.00	-37.68	-31.32 -6.64 Peak
4		275.43	-47.92	-13.00	-41.88	-34.92 -6.04 Peak
5		300.70	-49.47	-13.00	-43.10	-36.47 -6.37 Peak
6		408.50	-59.49	-13.00	-54.07	-46.49 -5.42 Peak
7		3465.00	-53.76	-13.00	-44.84	-40.76 -8.92 Peak

CHANNEL BANDWIDTH: 5MHz

MODE	Middle channel	Modulation	16QAM
RB / Offset	1 / 0	Polarization	Horizontal

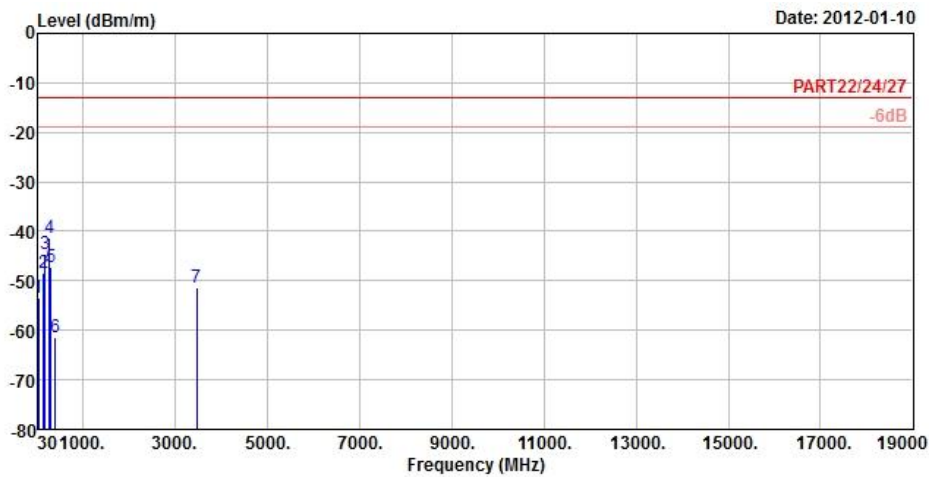

Site : 966 Chamber 2
 Condition: PART22/24/27 3m EIRP_RSE_1G~19G HORIZONTAL
 EUT : RJ83100
 Mode : LTE Band 4 (16QAM1,0) CH20175 5M
 Plane : X
 Sample NO: C120110-004-004-005

	Freq	Level	Limit	Read	Over		
	MHz	dBm/m	dBm/m	dBm	dB	dB/m	Remark
1	32.97	-53.34	-13.00	-52.23	-40.34	-1.11	Peak
2	143.13	-48.38	-13.00	-42.46	-35.38	-5.92	Peak
3	170.94	-44.55	-13.00	-37.83	-31.55	-6.72	Peak
4 pp	269.49	-41.37	-13.00	-35.42	-28.37	-5.95	Peak
5	301.40	-47.23	-13.00	-40.86	-34.23	-6.37	Peak
6	401.50	-61.31	-13.00	-55.72	-48.31	-5.59	Peak
7	3460.68	-51.32	-13.00	-42.40	-38.32	-8.92	Peak



A D T

CHANNEL BANDWIDTH: 5MHz

MODE	Middle channel	Modulation	16QAM
RB / Offset	1 / 0	Polarization	Vertical

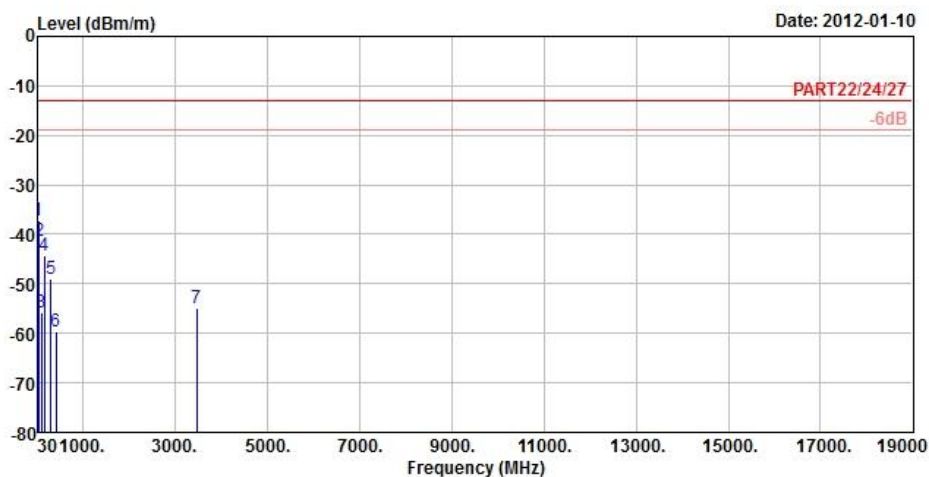

Site : 966 Chamber 2
 Condition: PART22/24/27 3m EIRP_RSE_1G~19G VERTICAL
 EUT : RJ83100
 Mode : LTE Band 4 (16QAM1,0) CH20175 5M
 Plane : X
 Sample NO: C120110-004-004-005

	Freq	Level	Limit	Read	Over	
	MHz	dBm/m	Line	Level	Limit	Factor Remark
			dBm/m	dBm	dB	dB/m
1	pp	30.00	-37.15	-13.00	-38.22	-24.15 1.07 Peak
2		43.23	-41.29	-13.00	-40.03	-28.29 -1.26 Peak
3		103.98	-55.85	-13.00	-45.37	-42.85 -10.48 Peak
4		165.81	-44.15	-13.00	-37.53	-31.15 -6.62 Peak
5		300.00	-48.88	-13.00	-42.50	-35.88 -6.38 Peak
6		417.60	-59.74	-13.00	-54.57	-46.74 -5.17 Peak
7		3460.68	-54.90	-13.00	-45.98	-41.90 -8.92 Peak



A D T

CHANNEL BANDWIDTH: 5MHz

MODE	Middle channel	Modulation	16QAM
RB / Offset	25 / 0	Polarization	Horizontal

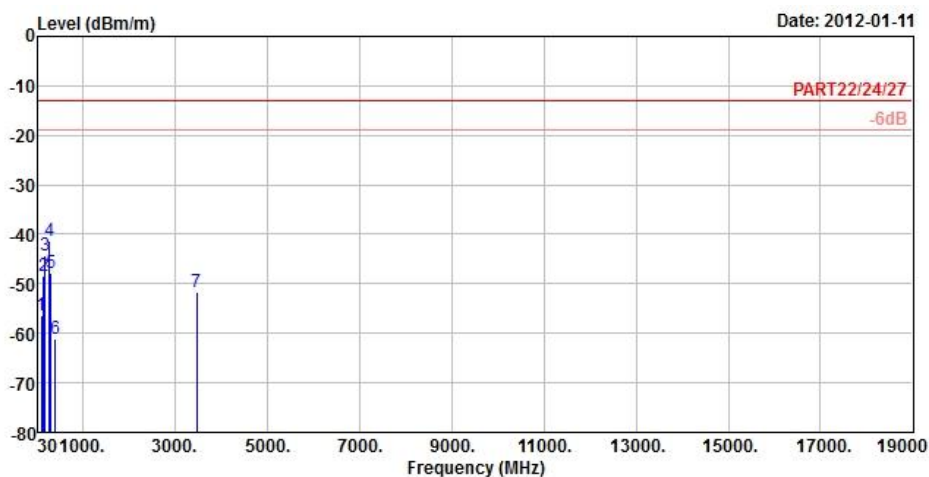

Site : 966 Chamber 2
 Condition: PART22/24/27 3m EIRP_RSE _1G~19G HORIZONTAL
 EUT : RJ83100
 Mode : LTE Band 4 (16QAM 25,0) CH19975 5M
 Plane : X
 Sample NO: C120110-004-004-005

	Freq	Level	Limit	Read	Over	
	MHz	dBm/m	Line	Level	Limit	Factor Remark
			dBm/m	dBm	dB	dB/m
1	98.04	-56.26	-13.00	-45.82	-43.26	-10.44 Peak
2	143.94	-48.51	-13.00	-42.59	-35.51	-5.92 Peak
3	170.13	-44.38	-13.00	-37.68	-31.38	-6.70 Peak
4 pp	269.22	-41.36	-13.00	-35.41	-28.36	-5.95 Peak
5	302.80	-47.75	-13.00	-41.39	-34.75	-6.36 Peak
6	403.60	-60.98	-13.00	-55.44	-47.98	-5.54 Peak
7	3465.00	-51.53	-13.00	-42.61	-38.53	-8.92 Peak



A D T

CHANNEL BANDWIDTH: 5MHz

MODE	Middle channel	Modulation	16QAM
RB / Offset	25 / 0	Polarization	Vertical

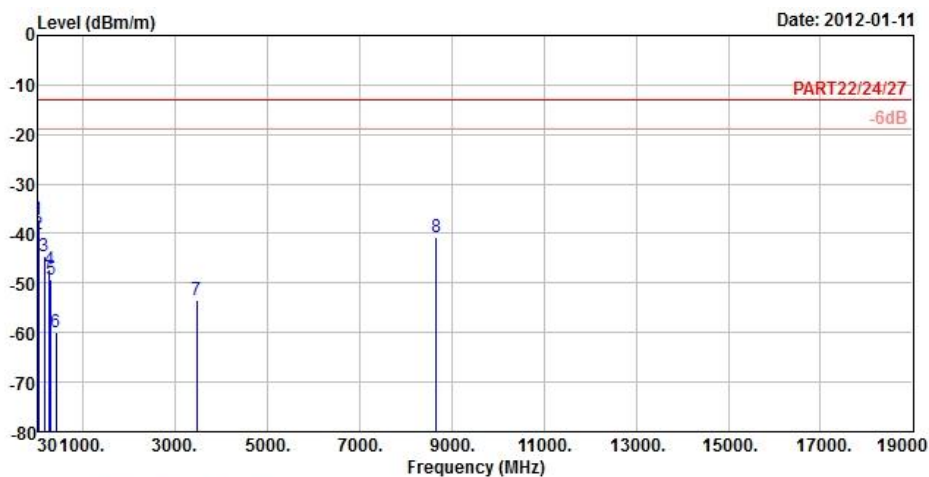

Site : 966 Chamber 2
 Condition: PART22/24/27 3m EIRP_RSE _1G~19G VERTICAL
 EUT : RJ83100
 Mode : LTE Band 4 (16QAM 25,0) CH19975 5M
 Plane : X
 Sample NO: C120110-004-004-005

	Freq	Level	Limit	Read	Over	
	MHz	dBm/m	dBm/m	dBm	dB	dB/m
1 pp	30.00	-37.30	-13.00	-38.37	-24.30	1.07 Peak
2	42.69	-40.16	-13.00	-38.83	-27.16	-1.33 Peak
3	165.00	-44.48	-13.00	-37.88	-31.48	-6.60 Peak
4	271.92	-47.33	-13.00	-41.35	-34.33	-5.98 Peak
5	300.00	-49.31	-13.00	-42.93	-36.31	-6.38 Peak
6	411.30	-59.81	-13.00	-54.46	-46.81	-5.35 Peak
7	3465.00	-53.45	-13.00	-44.53	-40.45	-8.92 Peak
8	8662.50	-40.80	-13.00	-46.89	-27.80	6.09 Peak

CHANNEL BANDWIDTH: 10MHz

MODE	Middle channel	Modulation	16QAM
RB / Offset	1 / 0	Polarization	Horizontal

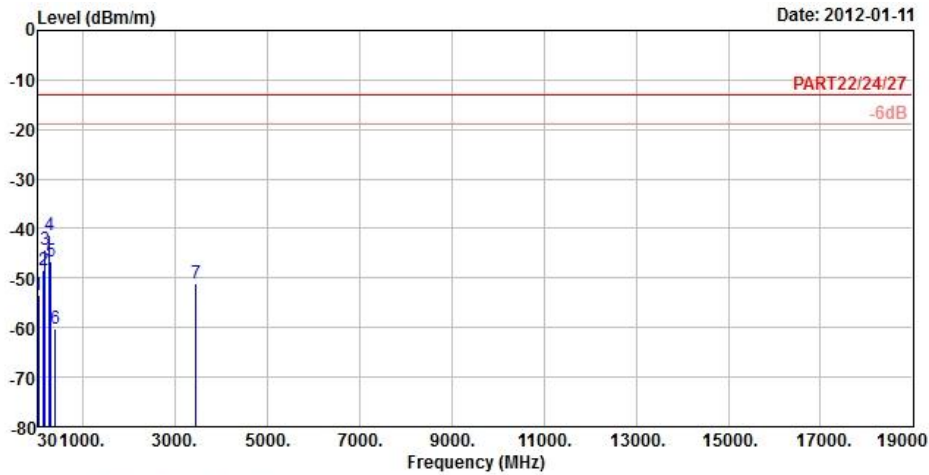

Site : 966 Chamber 2
 Condition: PART22/24/27 3m EIRP_RSE _1G~19G HORIZONTAL
 EUT : RJ83100
 Mode : LTE Band 4 (16QAM 1,0) CH20175 10M
 Plane : X
 Sample NO: C120110-004-004-005

	Freq	Level	Limit	Read	Over		
	MHz	dBm/m	dBm/m	dBm	dB	dB/m	
1	32.97	-53.42	-13.00	-52.31	-40.42	-1.11	Peak
2	144.21	-48.50	-13.00	-42.52	-35.50	-5.98	Peak
3	170.13	-44.39	-13.00	-37.69	-31.39	-6.70	Peak
4 pp	268.95	-41.45	-13.00	-35.51	-28.45	-5.94	Peak
5	300.00	-46.78	-13.00	-40.40	-33.78	-6.38	Peak
6	398.70	-60.31	-13.00	-54.66	-47.31	-5.65	Peak
7	3456.00	-51.09	-13.00	-42.15	-38.09	-8.94	Peak



A D T

CHANNEL BANDWIDTH: 10MHz

MODE	Middle channel	Modulation	16QAM
RB / Offset	1 / 0	Polarization	Vertical

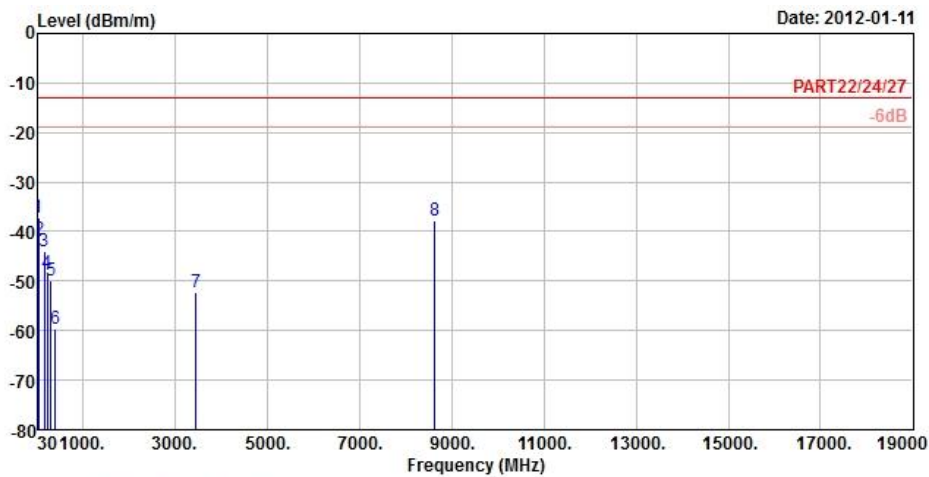

Site : 966 Chamber 2
 Condition: PART22/24/27 3m EIRP_RSE _1G~19G VERTICAL
 EUT : RJ83100
 Mode : LTE Band 4 (16QAM 1,0) CH20175 10M
 Plane : X
 Sample NO: C120110-004-004-005

	Freq	Level	Limit	Read	Over		
	MHz	dBm/m	dBm/m	dBm	dB	dB/m	Remark
1	pp	30.00	-37.34	-13.00	-38.41	-24.34	1.07 Peak
2		42.96	-41.52	-13.00	-40.19	-28.52	-1.33 Peak
3		165.81	-44.07	-13.00	-37.45	-31.07	-6.62 Peak
4		225.75	-48.54	-13.00	-41.77	-35.54	-6.77 Peak
5		300.70	-49.86	-13.00	-43.49	-36.86	-6.37 Peak
6		402.90	-59.62	-13.00	-54.05	-46.62	-5.57 Peak
7		3456.00	-52.13	-13.00	-43.19	-39.13	-8.94 Peak
8		8640.00	-37.73	-13.00	-43.46	-24.73	5.73 Peak



A D T

CHANNEL BANDWIDTH: 10MHz

MODE	Middle channel	Modulation	16QAM
RB / Offset	50 / 0	Polarization	Horizontal

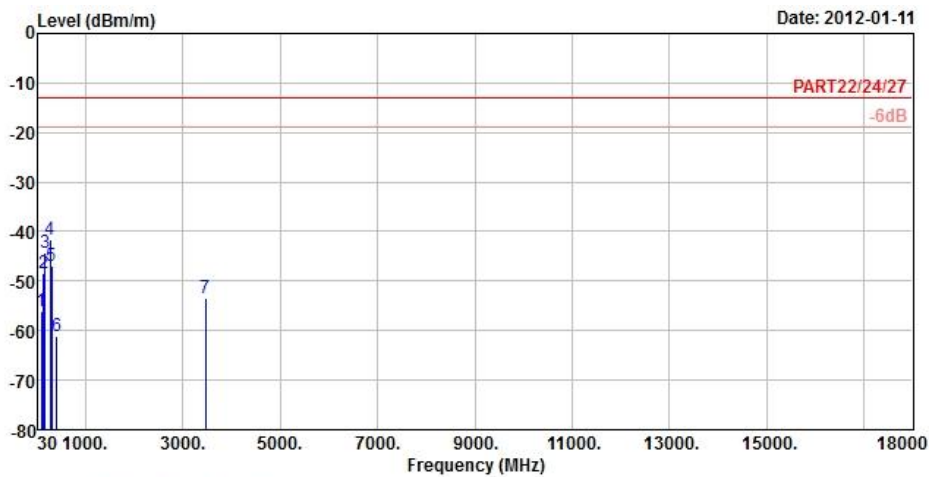

Site : 966 Chamber 2
 Condition: PART22/24/27 3m EIRP_RSE _1G~19G HORIZONTAL
 EUT : RJ83100
 Mode : LTE Band 4 (16QAM 50,0) CH20175 10M
 Plane : X
 Sample NO: C120110-004-004-005

	Freq	Level	Limit	Read	Over	
	MHz	dBm/m	Line	Level	Limit	Factor Remark
			dBm/m	dBm	dB	dB/m
1	95.88	-56.02	-13.00	-45.55	-43.02	-10.47 Peak
2	144.21	-48.42	-13.00	-42.44	-35.42	-5.98 Peak
3	170.67	-44.24	-13.00	-37.52	-31.24	-6.72 Peak
4 pp	269.49	-41.55	-13.00	-35.60	-28.55	-5.95 Peak
5	300.70	-47.01	-13.00	-40.64	-34.01	-6.37 Peak
6	404.30	-61.14	-13.00	-55.62	-48.14	-5.52 Peak
7	3465.00	-53.54	-13.00	-44.62	-40.54	-8.92 Peak

CHANNEL BANDWIDTH: 10MHz

MODE	Middle channel	Modulation	16QAM
RB / Offset	50 / 0	Polarization	Vertical

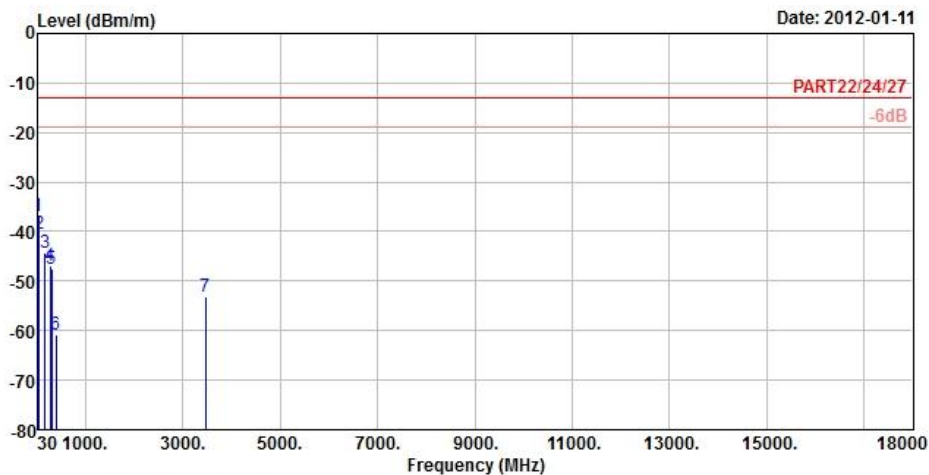

Site : 966 Chamber 2
 Condition: PART22/24/27 3m EIRP_RSE _1G~19G VERTICAL
 EUT : RJ83100
 Mode : LTE Band 4 (16QAM 50,0) CH20175 10M
 Plane : X
 Sample NO: C120110-004-004-005

	Freq	Level	Limit	Read	Over	
	MHz	dBm/m	dBm/m	dBm	dB	dB/m
1 pp	30.00	-37.02	-13.00	-38.09	-24.02	1.07 Peak
2	42.69	-40.54	-13.00	-39.21	-27.54	-1.33 Peak
3	165.54	-44.39	-13.00	-37.77	-31.39	-6.62 Peak
4	270.03	-47.05	-13.00	-41.10	-34.05	-5.95 Peak
5	300.00	-47.45	-13.00	-41.07	-34.45	-6.38 Peak
6	400.10	-60.68	-13.00	-55.06	-47.68	-5.62 Peak
7	3465.00	-53.08	-13.00	-44.16	-40.08	-8.92 Peak



5 INFORMATION ON THE TESTING LABORATORIES

We, Bureau Veritas Consumer Products Services (H.K.) Ltd., Taoyuan Branch, were founded in 1988 to provide our best service in EMC, Radio, Telecom and Safety consultation. Our laboratories are accredited and approved according to ISO/IEC 17025.

Copies of accreditation and authorization certificates of our laboratories obtained from approval agencies can be downloaded from our web site: www.adt.com.tw/index.5.phtml. If you have any comments, please feel free to contact us at the following:

Linko EMC/RF Lab:

Tel: 886-2-26052180

Fax: 886-2-26051924

Hsin Chu EMC/RF Lab:

Tel: 886-3-5935343

Fax: 886-3-5935342

Hwa Ya EMC/RF/Safety/Telecom Lab:

Tel: 886-3-3183232

Fax: 886-3-3185050

Email: service.adt@tw.bureauveritas.com

Web Site: www.adt.com.tw

The address and road map of all our labs can be found in our web site also.

6 APPENDIX A – MODIFICATIONS RECORDERS FOR ENGINEERING CHANGES TO THE EUT BY THE LAB

No modifications were made to the EUT by the lab during the test.

---END---