



FCC TEST REPORT

(PART 27)

REPORT NO.: RF120118C07-4

MODEL NO.: PJ40110

FCC ID: NM8PJ40110

RECEIVED: Jan. 18, 2012

TESTED: Feb. 20 ~ Feb. 21, 2012

ISSUED: Feb. 23, 2012

APPLICANT: HTC Corporation

ADDRESS: 23, Xinghua Rd., Taoyuan 330, Taiwan, R.O.C.

ISSUED BY: Bureau Veritas Consumer Products Services
(H.K.) Ltd., Taoyuan Branch

LAB ADDRESS: No. 47, 14th Ling, Chia Pau Vil., Lin Kou Dist.,
New Taipei City, Taiwan (R.O.C.)

TEST LOCATION: No. 19, Hwa Ya 2nd Rd, Wen Hwa Tsuen, Kwei
Shan Hsiang, Taoyuan Hsien 333, Taiwan, R.O.C.

This test report consists of 45 pages in total. It may be duplicated completely for legal use with the approval of the applicant. It should not be reproduced except in full, without the written approval of our laboratory. The client should not use it to claim product, certification, approval or endorsement by TAF or any government agency. The test results in the report only apply to the tested sample.



TABLE OF CONTENTS

RELEASE CONTROL RECORD	4
1 CERTIFICATION	5
2 SUMMARY OF TEST RESULTS	6
2.1 MEASUREMENT UNCERTAINTY	6
3 GENERAL INFORMATION	7
3.1 GENERAL DESCRIPTION OF EUT	7
3.2 DESCRIPTION OF TEST MODES	8
3.2.1 CONFIGURATION OF SYSTEM UNDER TEST	9
3.2.2 TEST MODE APPLICABILITY AND TESTED CHANNEL DETAIL	10
3.3 GENERAL DESCRIPTION OF APPLIED STANDARDS	12
3.4 DESCRIPTION OF SUPPORT UNITS	13
4 TEST TYPES AND RESULTS	14
4.1 OUTPUT POWER MEASUREMENT	14
4.1.1 LIMITS OF OUTPUT POWER MEASUREMENT	14
4.1.2 TEST INSTRUMENTS	15
4.1.3 TEST PROCEDURES	16
4.1.4 TEST SETUP	17
4.1.5 EUT OPERATING CONDITIONS	17
4.1.6 TEST RESULTS	18
4.2 FREQUENCY STABILITY MEASUREMENT	20
4.2.1 LIMITS OF FREQUENCY STABILITY MEASUREMENT	20
4.2.2 TEST INSTRUMENTS	20
4.2.3 TEST PROCEDURE	21
4.2.4 TEST SETUP	21
4.2.5 TEST RESULTS	22
4.3 OCCUPIED BANDWIDTH MEASUREMENT	23
4.3.1 LIMITS OF OCCUPIED BANDWIDTH MEASUREMENT	23
4.3.2 TEST INSTRUMENTS	23
4.3.3 TEST SETUP	23
4.3.4 TEST PROCEDURES	24
4.3.5 TEST RESULTS	25
4.4 PEAK TO AVERAGE RATIO	26
4.4.1 LIMITS OF PEAK TO AVERAGE RATIO MEASUREMENT	26
4.4.2 TEST INSTRUMENTS	26
4.4.3 TEST SETUP	26
4.4.4 TEST PROCEDURES	26
4.4.5 EUT OPERATING CONDITION	26
4.4.6 TEST RESULTS	27
4.5 BAND EDGE MEASUREMENT	28
4.5.1 LIMITS OF BAND EDGE MEASUREMENT	28



A D T

4.5.2	TEST INSTRUMENTS	28
4.5.3	TEST SETUP	28
4.5.4	TEST PROCEDURES	29
4.5.5	EUT OPERATING CONDITION	29
4.5.6	TEST RESULTS	30
4.6	CONDUCTED SPURIOUS EMISSIONS	31
4.6.1	LIMITS OF CONDUCTED SPURIOUS EMISSIONS MEASUREMENT	31
4.6.2	TEST INSTRUMENTS	31
4.6.3	TEST PROCEDURE	32
4.6.4	TEST SETUP	32
4.6.5	EUT OPERATING CONDITIONS	32
4.6.6	TEST RESULTS	33
4.7	RADIATED EMISSION MEASUREMENT	36
4.7.1	LIMITS OF RADIATED EMISSION MEASUREMENT	36
4.7.2	TEST INSTRUMENTS	37
4.7.3	TEST PROCEDURES	38
4.7.4	DEVIATION FROM TEST STANDARD	38
4.7.5	TEST SETUP	39
4.7.6	EUT OPERATING CONDITIONS	39
4.7.7	TEST RESULTS	40
5	INFORMATION ON THE TESTING LABORATORIES	44
6	APPENDIX A – MODIFICATIONS RECORDERS FOR ENGINEERING CHANGES TO THE EUT BY THE LAB	45



A D T

RELEASE CONTROL RECORD

ISSUE NO.	REASON FOR CHANGE	DATE ISSUED
Original release	N/A	Feb. 20, 2012



1 CERTIFICATION

PRODUCT: Smartphone
MODEL NO.: PJ40110
BRAND: HTC
APPLICANT: HTC Corporation
TESTED: Feb. 20 ~ Feb. 21, 2012
TEST SAMPLE: Production Unit
TEST STANDARDS: **FCC Part 27, Subpart C, L**
FCC Part 2

The above equipment (model: PJ40110) has been tested by **Bureau Veritas Consumer Products Services (H.K.) Ltd., Taoyuan Branch**, and found compliance with the requirement of the above standards. The test record, data evaluation & Equipment Under Test (EUT) configurations represented herein are true and accurate accounts of the measurements of the sample's EMC characteristics under the conditions specified in this report.

PREPARED BY :  , DATE: Feb. 23, 2012
Pettie Chen / Specialist

APPROVED BY :  , DATE: Feb. 23, 2012
Gary Chang / Technical Manager

2 SUMMARY OF TEST RESULTS

The EUT has been tested according to the following specifications:

OPERATING BAND: 1710~1755 MHz			
STANDARD SECTION	TEST TYPE AND LIMIT	RESULT	REMARK
2.1046 27.50(d)(4)	Maximum Peak Output Power	PASS	Meet the requirement of limit. Minimum passing margin is 22.14dBm at 1712.4MHz.
2.1055 27.54	Frequency Stability	PASS	Meet the requirement of limit.
2.1049 27.53(h)	Occupied Bandwidth	PASS	Meet the requirement of limit.
27.50(d)(5)	Peak to average ratio	PASS	Meet the requirement of limit.
27.53(h)	Band Edge Measurements	PASS	Meet the requirement of limit.
2.1051 27.53(h)	Conducted Spurious Emissions	PASS	Meet the requirement of limit.
2.1053 27.53(h)	Radiated Spurious Emissions	PASS	Meet the requirement of limit. Minimum passing margin is -24.18dB at 30.00MHz.

2.1 MEASUREMENT UNCERTAINTY

Where relevant, the following measurement uncertainty levels have been estimated for tests performed on the EUT as specified in CISPR 16-4-2:

MEASUREMENT	FREQUENCY	UNCERTAINTY
Conducted emissions	9kHz~30MHz	2.44 dB
Radiated emissions	30MHz ~ 200MHz	2.93 dB
	200MHz ~1000MHz	2.95 dB
	1GHz ~ 18GHz	2.26 dB
	18GHz ~ 40GHz	1.94 dB

This uncertainty represents an expanded uncertainty expressed at approximately the 95% confidence level using a coverage factor of k=2.

3 GENERAL INFORMATION

3.1 GENERAL DESCRIPTION OF EUT

PRODUCT	Smart Phone
MODEL NO.	PJ40110
FCC ID	NM8PJ40110
POWER SUPPLY	5.0Vdc (adapter or host equipment) 3.7Vdc (battery)
OPERATION TEMPERATURE RANGE	-10°C ~ 55°C
MODULATION TECHNOLOGY	BPSK
FREQUENCY RANGE	1712.4MHz ~1752.6MHz
MAX. EIRP POWER (W)	0.164W
WCDMA RELEASE VERSION	6
ANTENNA TYPE	Fixed internal antenna with -0.88dBi gain
DATA CABLE	Refer to users' manual
I/O PORTS	Refer to Note as below
ACCESSORY DEVICES	Refer to Note as below

NOTE:

- The EUT's accessories list refers to EUT photo.
*Main sample with battery 1 & 2nd sample with battery 2 + item 1, 5, 7, 10, 11, 12 were for the final test.
- The above EUT information is declared by manufacturer and for more detailed features description, please refer to the manufacturer's specifications or User's Manual.

3.2 DESCRIPTION OF TEST MODES

Three channels had been tested for each channel bandwidth.

CHANNEL BANDWIDTH	Channel	Frequency(MHz)
Low channel (L)	1312	1712.4
Middle channel (M)	1413	1732.6
High channel (H)	1513	1752.6

3.2.1 CONFIGURATION OF SYSTEM UNDER TEST

<For Radiated Emission Test>

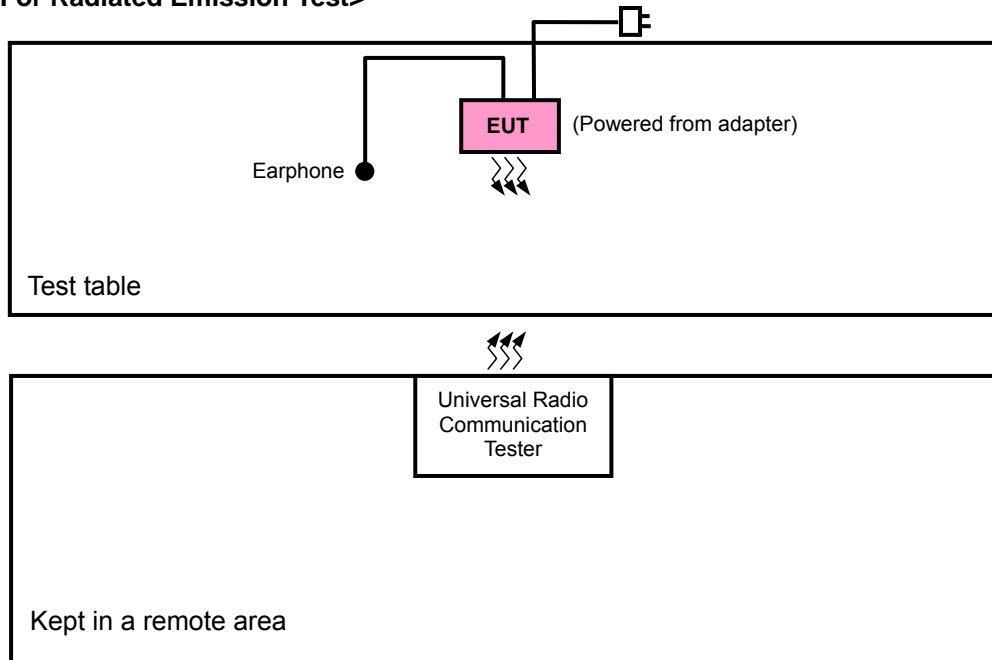

<For Output Power Test>

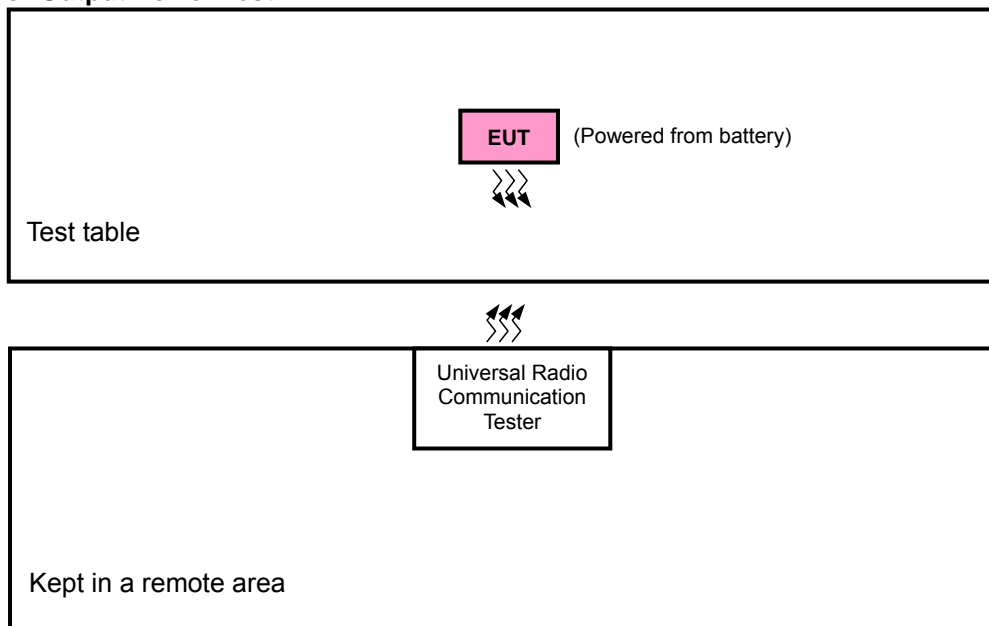

3.2.2 TEST MODE APPLICABILITY AND TESTED CHANNEL DETAIL

EUT CONFIGURE MODE	APPLICABLE TO							DESCRIPTION
	OP	FS	OB	PA	BE	CE	RE	
A	V	V	V	V	V	V	V	Main Sample
B	V	-	-	-	-	-	V	Second Sample

Where **OP**: Output power **FS**: Frequency stability
OB: Occupied bandwidth **PA**: Peak to Average Ratio
BE: Band edge **CE**: Conducted spurious emissions
RE: Radiated emission **NOTE**: "-": Means no effect.

OUTPUT POWER MEASUREMENT:

- Pre-Scan has been conducted to determine the worst-case mode from all possible combinations between available modulations, XYZ axis and antenna ports (if EUT with antenna diversity architecture).
- Following channel(s) was (were) selected for the final test as listed below.

EUT CONFIGURE MODE	OPERATING BAND	AVAILABLE CHANNEL	TESTED CHANNEL	MODULATION TECHNOLOGY	AXIS
A, B	WCDMA AWS Band	1312 to 1513	1312, 1413, 1513	BPSK	Y

FREQUENCY STABILITY MEASUREMENT:

- Pre-Scan has been conducted to determine the worst-case mode from all possible combinations between available modulations and antenna ports (if EUT with antenna diversity architecture).
- Following channel(s) was (were) selected for the final test as listed below.

EUT CONFIGURE MODE	OPERATING BAND	AVAILABLE CHANNEL	TESTED CHANNEL	MODULATION TECHNOLOGY
A	WCDMA AWS Band	1312 to 1513	1413	BPSK

OCCUPIED BANDWIDTH MEASUREMENT:

- This item includes all test value of each mode, but only includes spectrum plot of worst value of each mode.
- Pre-Scan has been conducted to determine the worst-case mode from all possible combinations between available modulations and antenna ports (if EUT with antenna diversity architecture).
- Following channel(s) was (were) selected for the final test as listed below.

EUT CONFIGURE MODE	OPERATING BAND	AVAILABLE CHANNEL	TESTED CHANNEL	MODULATION TECHNOLOGY
A	WCDMA AWS Band	1312 to 1513	1413	BPSK

PEAK TO AVERAGE RATIO:

- This item includes all test value of each mode, but only includes spectrum plot of worst value of each mode.
- Pre-Scan has been conducted to determine the worst-case mode from all possible combinations between available modulations and antenna ports (if EUT with antenna diversity architecture).
- Following channel(s) was (were) selected for the final test as listed below.

EUT CONFIGURE MODE	OPERATING BAND	AVAILABLE CHANNEL	TESTED CHANNEL	MODULATION TECHNOLOGY
A	WCDMA AWS Band	1312 to 1513	1413	BPSK

BAND EDGE MEASUREMENT:

- Pre-Scan has been conducted to determine the worst-case mode from all possible combinations between available modulations and antenna ports (if EUT with antenna diversity architecture).
- Following channel(s) was (were) selected for the final test as listed below.

EUT CONFIGURE MODE	OPERATING BAND	AVAILABLE CHANNEL	TESTED CHANNEL	MODULATION TECHNOLOGY
A	WCDMA AWS Band	1312 to 1513	1312, 1513	BPSK

CONDUCTED SPURIOUS EMISSIONS MEASUREMENT:

- Pre-Scan has been conducted to determine the worst-case mode from all possible combinations between available modulations and antenna ports (if EUT with antenna diversity architecture).
- Following channel(s) was (were) selected for the final test as listed below.

EUT CONFIGURE MODE	OPERATING BAND	AVAILABLE CHANNEL	TESTED CHANNEL	MODULATION TECHNOLOGY
A	WCDMA AWS Band	1312 to 1513	1413	BPSK

RADIATED EMISSION MEASUREMENT:

- Pre-Scan has been conducted to determine the worst-case mode from all possible combinations between available modulations, XYZ axis and antenna ports (if EUT with antenna diversity architecture).
- Following channel(s) was (were) selected for the final test as listed below.

EUT CONFIGURE MODE	OPERATING BAND	AVAILABLE CHANNEL	TESTED CHANNEL	MODULATION TECHNOLOGY	AXIS
A, B	WCDMA AWS Band	1312 to 1513	1312, 1413, 1513	BPSK	X

TEST CONDITION:

APPLICABLE TO	ENVIRONMENTAL CONDITIONS	INPUT POWER (SYSTEM)	TESTED BY
OP	25deg. C, 57%RH	3.8Vdc	Phoenix Chen
FS	25deg. C, 57%RH	3.8Vdc	Phoenix Chen
OB	25deg. C, 57%RH	3.8Vdc	Phoenix Chen
PA	25deg. C, 57%RH	3.8Vdc	Phoenix Chen
BE	25deg. C, 57%RH	3.8Vdc	Phoenix Chen
CE	25deg. C, 57%RH	3.8Vdc	Phoenix Chen
RE	25deg. C, 65%RH	120Vac, 60Hz	David Huang

3.3 GENERAL DESCRIPTION OF APPLIED STANDARDS

The EUT is a RF product. According to the specifications of the manufacturer, it must comply with the requirements of the following standards:

FCC 47 CFR Part 2

FCC 47 CFR Part 27

ANSI C63.4-2003

ANSI/TIA/EIA-603-C 2004

NOTE: All test items have been performed and recorded as per the above standards.

3.4 DESCRIPTION OF SUPPORT UNITS

The EUT has been tested as an independent unit together with other necessary accessories or support units. The following support units or accessories were used to form a representative test configuration during the tests.

NO.	PRODUCT	BRAND	MODEL NO.	SERIAL NO.	FCC ID
1	EARPHONE	KINGSTATE	HS G235	NA	NA
2	UNIVERSAL RADIO COMMUNICATION TESTER	R&S	CMU200	104484	NA
3	RADIO COMMUNICATION ANALYZER	Anritsu	MT8820C	6201010284	NA

NO.	SIGNAL CABLE DESCRIPTION OF THE ABOVE SUPPORT UNITS
1	NA
2	NA
3	NA

NOTE:

1. Item 1 was provided by client.
2. Item 2, 3 acted as a communication partners to transfer data.

4 TEST TYPES AND RESULTS

4.1 OUTPUT POWER MEASUREMENT

4.1.1 LIMITS OF OUTPUT POWER MEASUREMENT

Fixed, mobile, and portable (hand-held) stations operating in the 1710–1755 MHz band are limited to 1 watt EIRP.

4.1.2 TEST INSTRUMENTS

DESCRIPTION & MANUFACTURER	MODEL NO.	SERIAL NO.	DATE OF CALIBRATION	DUE DATE OF CALIBRATION
Test Receiver Agilent	N9038A	MY51210203	Dec. 22, 2011	Dec. 21, 2012
Spectrum Analyzer ROHDE & SCHWARZ	FSU43	101261	Dec. 21, 2011	Dec. 20, 2012
BILOG Antenna SCHWARZBECK	VULB9168	9168-472	Dec. 20, 2011	Dec. 19, 2012
HORN Antenna SCHWARZBECK	BBHA 9120 D	9120D-969	Dec. 20, 2011	Dec. 19, 2012
HORN Antenna SCHWARZBECK	BBHA 9170	9170-480	Dec. 20, 2011	Dec. 19, 2012
Preamplifier EMCI	EMC 012645	980115	Dec. 30, 2011	Dec. 29, 2012
Preamplifier EMCI	EMC 330H	980112	Dec. 30, 2011	Dec. 29, 2012
RF signal cable HUBER+SUHNNER	SUCOFLEX 104	309219/4	Oct. 21, 2011	Oct. 20, 2012
RF signal cable HUBER+SUHNNER	SUCOFLEX 104	250130/4	Jan. 02, 2012	Jan. 01, 2013
RF signal cable Worken	RG-213	NA	Jan. 02, 2012	Jan. 01, 2013
Software	E3 6.120103	NA	NA	NA
Antenna Tower MF	MFA-440H	NA	NA	NA
Turn Table MF	MFT-201SS	NA	NA	NA
Antenna Tower & Turn Table Controller MF	MF-7802	NA	NA	NA

- NOTE:**
1. The calibration interval of the above test instruments is 12 months and the calibrations are traceable to NML/ROC and NIST/USA.
 2. The test was performed in HwaYa Chamber 9.
 3. The horn antenna and HP preamplifier (model: 8449B) are used only for the measurement of emission frequency above 1GHz if tested.
 4. The FCC Site Registration No. is 460141.
 5. The IC Site Registration No. is IC 7450F-4.

4.1.3 TEST PROCEDURES

EIRP / ERP MEASUREMENT:

- a. The EUT was set up for the maximum power with WCDMA link data modulation. The power was measured with R&S Spectrum Analyzer. All measurements were done at 3 channels (low, middle and high operational frequency range).
- b. E.I.R.P power measurement. In the semi-anechoic chamber, EUT placed on the 0.8m height of Turn Table, rotated the table around 360 degrees to search the maximum radiation power and receiver antenna shall be rotated vertical and horizontal polarization and moved height from 1m to 4m to find the maximum polar radiated power. The “Read Value” is the spectrum reading the maximum power value.
- c. The substitution horn antenna is substituted for EUT at the same position and signals generator export the CW signal to the substitution antenna via a TX cable. Rotated the Turn Table and moved receiving antenna to find the maximum radiation power. Adjust output power level of S.G to get a Value of spectrum reading equal to “Read Value” of step a. Record the power level of S.G
- d. $EIRP = \text{Output power level of S.G} - \text{TX cable loss} + \text{Antenna gain of substitution horn}$
- e. $E.R.P = E.I.R.P - 2.15 \text{ dB}$

CONDUCTED POWER MEASUREMENT:

- a. The EUT was set up for the maximum power with WCDMA link data modulation and link up with simulator.
- b. Set the EUT to transmit under low, middle and high channel and record the power level shown on simulator.

4.1.4 TEST SETUP

EIRP / ERP MEASUREMENT:

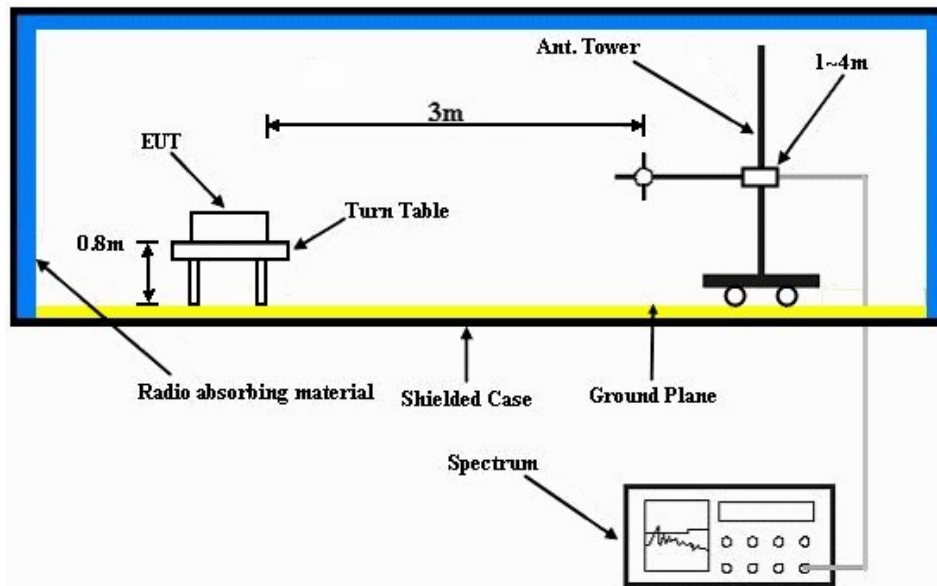

For the actual test configuration, please refer to the attached file (Test Setup Photo).

CONDUCTED POWER MEASUREMENT:

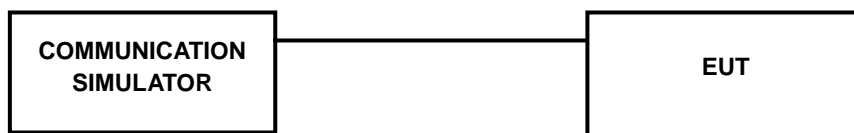

For the actual test configuration, please refer to the attached file (Test Setup Photo).

4.1.5 EUT OPERATING CONDITIONS

- a. The EUT makes a call to the communication simulator.
- b. The communication simulator station system controlled an EUT to export maximum output power under transmission mode and specific channel frequency.

4.1.6 TEST RESULTS

CONDUCTED OUTPUT POWER (dBm)

Band	WCDMA IV		
	1312	1413	1513
Channel	1712.4	1732.6	1752.6
Frequency (MHz)	1712.4	1732.6	1752.6
RMC 12.2K	23.15	23.01	23.18
HSDPA Subtest-1	21.68	21.63	21.67
HSDPA Subtest-2	21.60	21.49	21.52
HSDPA Subtest-3	21.67	21.54	21.55
HSDPA Subtest-4	21.67	21.53	21.64
HSUPA Subtest-1	21.80	21.13	21.22
HSUPA Subtest-2	19.98	19.54	19.86
HSUPA Subtest-3	20.48	20.27	20.37
HSUPA Subtest-4	19.03	18.89	19.17
HSUPA Subtest-5	21.83	21.72	21.89



A D T

EIRP POWER

Test Mode A

Plane	Channel	Frequency (MHz)	LVL (dBm)	Correction Factor(dB)	EIRP(dBm)	EIRP(W)	Polarization (H/V)
Y	1312	1712.4	-27.66	37.90	10.24	0.011	H
	1413	1732.6	-25.24	37.99	12.75	0.019	H
	1513	1752.6	-27.17	38.31	11.14	0.013	H
	1312	1712.4	-15.67	37.81	22.14	0.164	V
	1413	1732.6	-15.37	37.40	22.03	0.160	V
	1513	1752.6	-16.27	38.22	21.95	0.157	V

Test Mode B

Plane	Channel	Frequency (MHz)	LVL (dBm)	Correction Factor(dB)	EIRP(dBm)	EIRP(W)	Polarization (H/V)
Y	1312	1712.4	-26.92	37.90	10.98	0.013	H
	1413	1732.6	-26.51	37.99	11.48	0.014	H
	1513	1752.6	-26.40	38.31	11.91	0.016	H
	1312	1712.4	-16.64	37.81	21.17	0.131	V
	1413	1732.6	-16.95	37.40	20.45	0.111	V
	1513	1752.6	-17.79	38.22	20.43	0.110	V

4.2 FREQUENCY STABILITY MEASUREMENT

4.2.1 LIMITS OF FREQUENCY STABILITY MEASUREMENT

According to the FCC part 27.54 shall be tested the frequency stability. The rule is defined that” The frequency stability shall be sufficient to ensure that the fundamental emissions stay within the authorized bands of operation.

4.2.2 TEST INSTRUMENTS

DESCRIPTION & MANUFACTURER	MODEL NO.	SERIAL NO.	DATE OF CALIBRATION	DUE DATE OF CALIBRATION
* Hewlett Packard RF cable	8120-6192	01428251	NA	NA
* Suhner RF cable	Sucoflex104	257029	Sep. 11, 2011	Sep. 10, 2012
* WIT Standard Temperature & Humidity Chamber	MHU-225AU	920842	Jun. 15, 2011	Jun. 14, 2012

- NOTE:** 1. The calibration interval of the above test instruments is 12 months. And the calibrations are traceable to NML/ROC and NIST/USA.
2. “*” = These equipments are used for the final measurement.
3. The test was performed in ADT RF OVEN room.

4.2.3 TEST PROCEDURE

- a. Because of the measure the carrier frequency under the condition of the AFC lock, it shall be used the mobile station in the WCDMA link mode. This is accomplished with the use of the communication simulator station. The oven room could control the temperatures and humidity.
- b. Power must be removed when changing from one temperature to another or one voltage to another voltage. Power warm up is at least 15 min and power applied should perform before recording frequency error.
- c. EUT is connected the external power supply to control the DC input power. The various Volts from the minimum 3.6 Volts to 4.2 Volts. Each step shall be record the frequency error rate.
- d. The temperature range step is 10 degrees in this test items. All temperature levels shall be hold the $\pm 0.5^{\circ}\text{C}$ during the measurement testing.
- e. The each temperature step shall be at least 0.5 hours, consider the EUT could be test under the stability condition.

NOTE: The frequency error was recorded frequency error from the communication simulator.

4.2.4 TEST SETUP

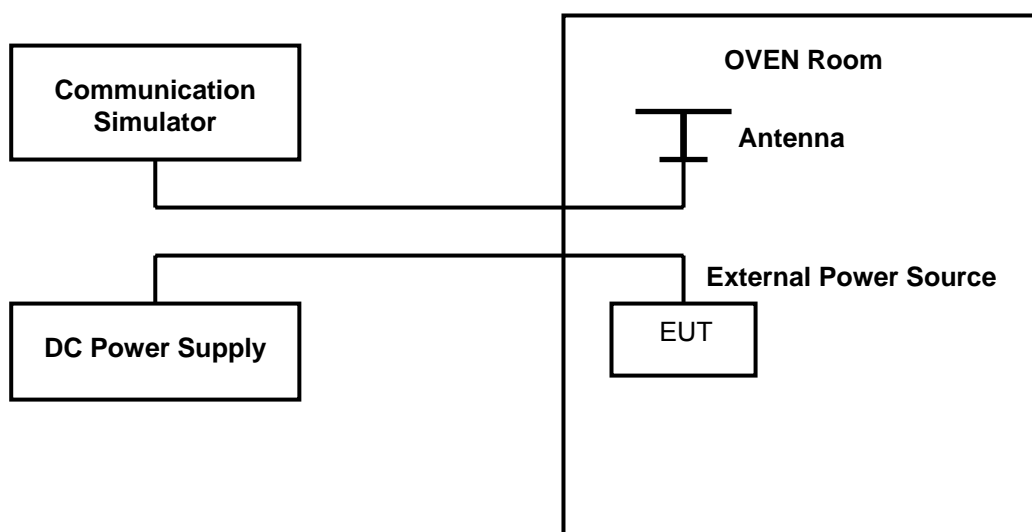

4.2.5 TEST RESULTS

AFC FREQUENCY ERROR vs. VOLTAGE		
VOLTAGE (Volts)	FREQUENCY ERROR (ppm)	LIMIT (ppm)
3.8	0.003	2.5
3.6	0.002	2.5
4.2	0.002	2.5

NOTE: The applicant defined the normal working voltage of the host equipment is from 3.6Vdc to 4.2Vdc.

AFC FREQUENCY ERROR vs. TEMP.		
TEMP. (°C)	FREQUENCY ERROR (ppm)	LIMIT (ppm)
-10	0.003	2.5
0	0.002	2.5
10	0.002	2.5
20	0.003	2.5
30	0.002	2.5
40	0.003	2.5
50	0.002	2.5
55	0.002	2.5

4.3 OCCUPIED BANDWIDTH MEASUREMENT

4.3.1 LIMITS OF OCCUPIED BANDWIDTH MEASUREMENT

The width of a frequency band such that, below the lower and above the upper frequency limits, the mean powers emitted are each equal to a specified percentage 0.5 % of the total mean power of a given emission.

4.3.2 TEST INSTRUMENTS

DESCRIPTION & MANUFACTURER	MODEL NO.	SERIAL NO.	DATE OF CALIBRATION	DUE DATE OF CALIBRATION
* Mini-Circuits Power Splitter	ZAPD-4	NA	Mar. 24, 2011	Mar. 23, 2012
* Hewlett Packard RF cable	8120-6192	274388	Oct. 22, 2011	Oct. 21, 2012
* JFW 20dB attenuation	50HF-020-SMA	NA	NA	NA
* Suhner RF cable	Sucoflex104	274403/4	Aug. 20, 2011	Aug. 19, 2012
* ROHDE & SCHWARZ Spectrum Analyzer	E4446A	MY44360128	Feb. 20, 2012	Feb. 19, 2013

NOTE: 1. The calibration interval of the above test instruments is 12 months. And the calibrations are traceable to NML/ROC and NIST/USA.

2. "*" = These equipments are used for the final measurement.

4.3.3 TEST SETUP

Same as Item 4.1.4 (Conducted Power Setup)

4.3.4 TEST PROCEDURES

- a. The EUT makes a call to the communication simulator. The power was measured with R&S Spectrum Analyzer. All measurements were done at 3 channels, 1312, 1413 and 1513 (WCDMA) (low, middle and high operational frequency range.)
- b. The conducted occupied bandwidth used the power splitter via EUT RF power connector between simulation base station and spectrum analyzer.
- c. The communication simulator station system controlled a EUT to export maximum output power under transmission mode and specific channel frequency. Use OBW measurement function of Spectrum analyzer to measure 99 % occupied bandwidth.



A D T

4.3.5 TEST RESULTS

CHANNEL	FREQUENCY (MHz)	99% OCCUPIED BANDWIDTH (MHz)
1312	1712.4	4.1839
1413	1732.6	4.1841
1513	1752.6	4.1770

CH 1413

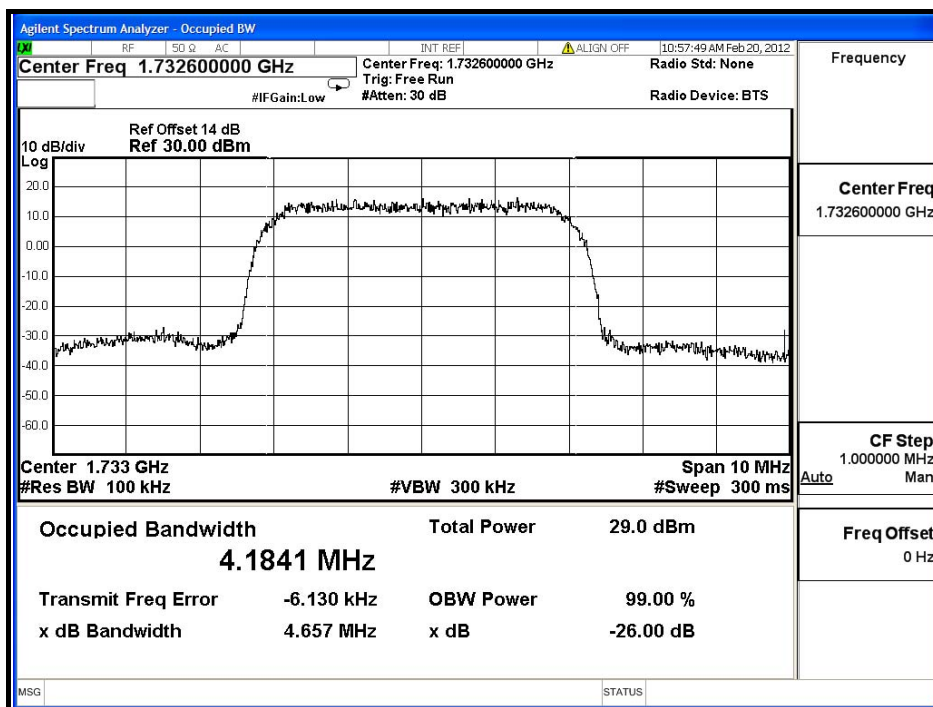

4.4 PEAK TO AVERAGE RATIO

4.4.1 LIMITS OF PEAK TO AVERAGE RATIO MEASUREMENT

In measuring transmissions in this band using an average power technique, the peak to-average ratio (PAR) of the transmission may not exceed 13 dB

4.4.2 TEST INSTRUMENTS

DESCRIPTION & MANUFACTURER	MODEL NO.	SERIAL NO.	DATE OF CALIBRATION	DUE DATE OF CALIBRATION
* ROHDE & SCHWARZ Spectrum Analyzer	FSP40	100039	Feb. 03, 2012	Feb. 02, 2013
* Agilent Spectrum Analyzer	E4446A	MY44360128	Feb. 20, 2012	Feb. 19, 2013
* Mini-Circuits Power Splitter	ZN2PD-9G	NA	May 25, 2011	May 24, 2012
* Hewlett Packard RF cable	8120-6192	274388	Oct. 22, 2011	Oct. 21, 2012
* JFW 20dB attenuation	50HF-020-SMA	NA	NA	NA
* Suhner RF cable	Sucoflex104	274403/4	Aug. 20, 2011	Aug. 19, 2012

NOTE: 1. The calibration interval of the above test instruments is 12 months. And the calibrations are traceable to NML/ROC and NIST/USA.

2. "*" = These equipments are used for the final measurement.

4.4.3 TEST SETUP

Same as Item 4.2.4 (Conducted Power Setup)

4.4.4 TEST PROCEDURES

1. Set resolution/measurement bandwidth \geq signal's occupied bandwidth;
2. Set the number of counts to a value that stabilizes the measured CCDF curve;
3. Record the maximum PAPR level associated with a probability of 0.1%.

4.4.5 EUT OPERATING CONDITION

Same as Item 4.1.5

4.4.6 TEST RESULTS

FREQUENCY (MHz)	PEAK TO AVERAGE RATIO (dB)
1732.6	2.98

CH 1413

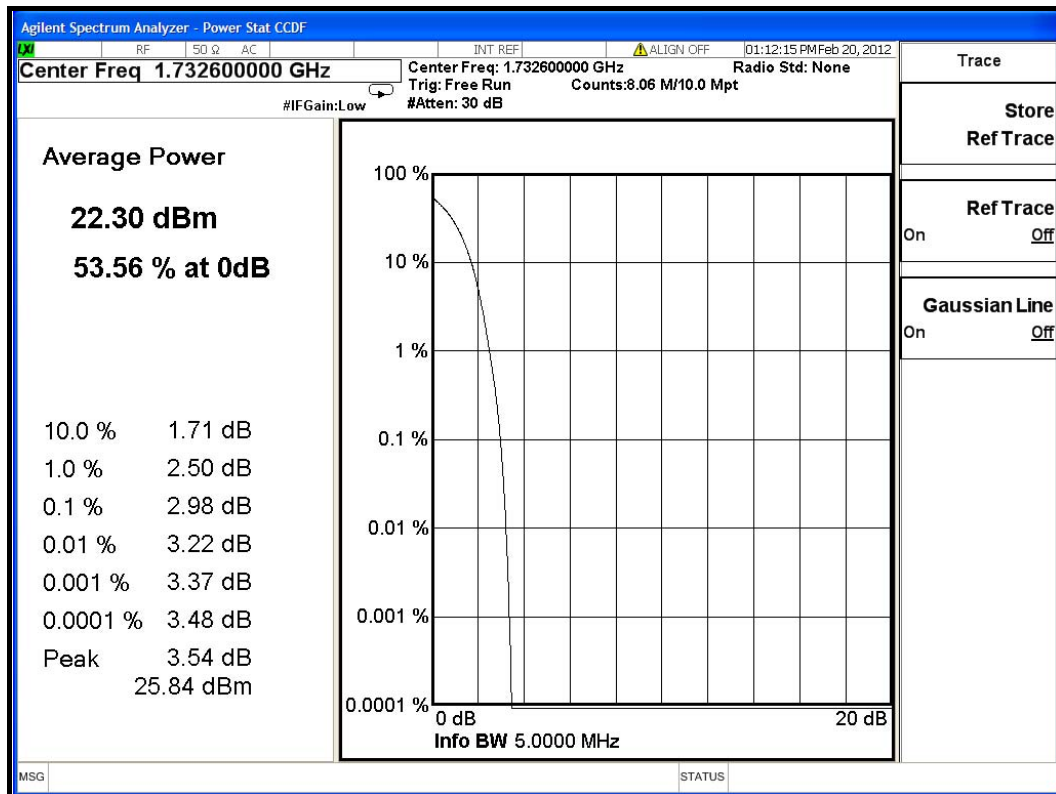

4.5 BAND EDGE MEASUREMENT

4.5.1 LIMITS OF BAND EDGE MEASUREMENT

For operations in the 1710–1755 MHz band, the power of any emission outside a licensee's frequency block shall be attenuated below the transmitter power (P) by at least $43 + 10 \log_{10}(P)$ dB. The limit of emission equal to -13 dBm. In the 1 MHz bands immediately outside and adjacent to the frequency block a resolution bandwidth of at least one percent of the emission bandwidth of the fundamental emission of the transmitter may be employed.

4.5.2 TEST INSTRUMENTS

DESCRIPTION & MANUFACTURER	MODEL NO.	SERIAL NO.	DATE OF CALIBRATION	DUE DATE OF CALIBRATION
* ROHDE & SCHWARZ Spectrum Analyzer	FSP40	100039	Feb. 03, 2012	Feb. 02, 2013
* Mini-Circuits Power Splitter	ZN2PD-9G	NA	May 25, 2011	May 24, 2012
* Hewlett Packard RF cable	8120-6192	274388	Oct. 22, 2011	Oct. 21, 2012
* JFW 20dB attenuation	50HF-020-SMA	NA	NA	NA
* Suhner RF cable	Sucoflex104	274403/4	Aug. 20, 2011	Aug. 19, 2012

NOTE: 1. The calibration interval of the above test instruments is 12 months. And the calibrations are traceable to NML/ROC and NIST/USA.

2. "*" = These equipments are used for the final measurement.

4.5.3 TEST SETUP

Same as Item 4.1.4 (Conducted Power Setup)

4.5.4 TEST PROCEDURES

- a. The EUT was set up for the maximum peak power with WCDMA link data modulation. The power was measured with R&S Spectrum Analyzer. All measurements were done at 2 channels (low and high operational frequency range.).
- b. The band edge measurement used the power splitter via EUT RF power connector between simulation base station and spectrum analyzer.
- c. The center frequency of spectrum is the band edge frequency and span is 5 MHz. RB of the spectrum is 100kHz and VB of the spectrum is 300kHz.
- d. Record the max trace plot into the test report.

4.5.5 EUT OPERATING CONDITION

- a. The EUT makes a call to the communication simulator.
- b. The communication simulator station system controlled an EUT to export maximum output power under transmission mode and specific channel frequency.



A D T

4.5.6 TEST RESULTS

LOWER BAND EDGE

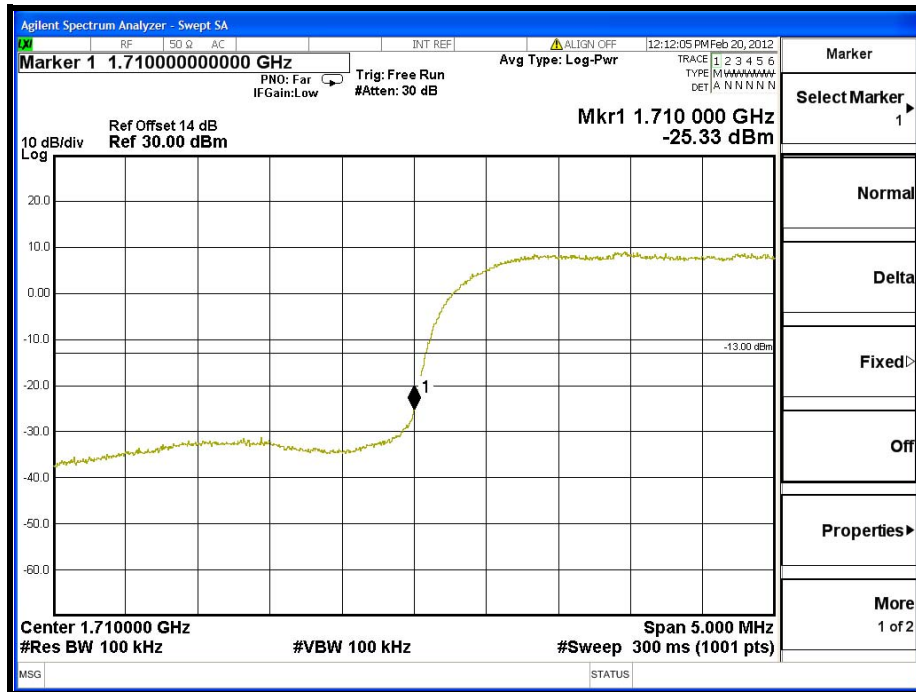

HIGHER BAND EDGE

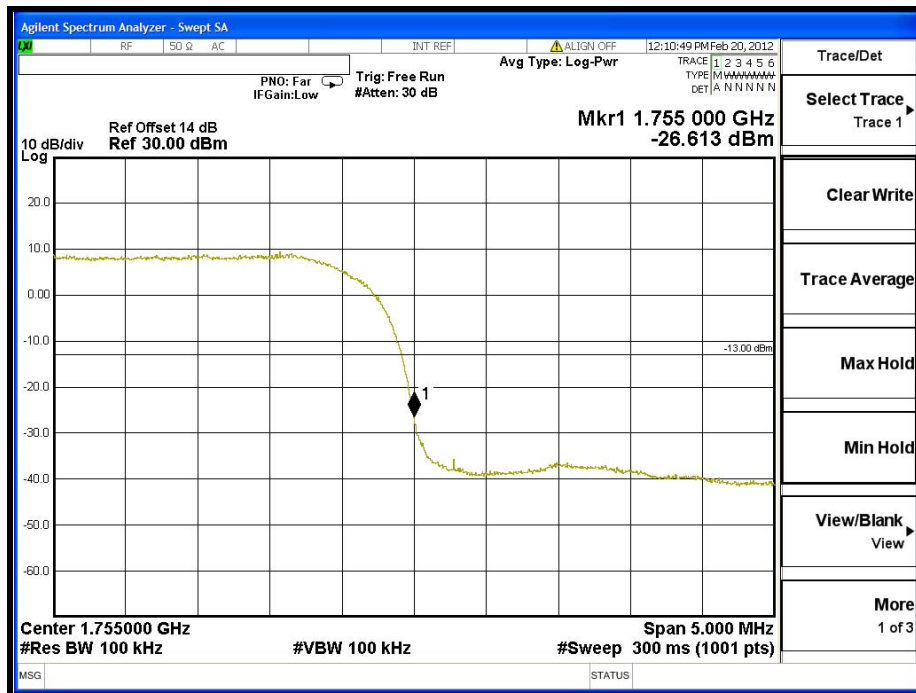

4.6 CONDUCTED SPURIOUS EMISSIONS

4.6.1 LIMITS OF CONDUCTED SPURIOUS EMISSIONS MEASUREMENT

The power of any emission outside a licensee's frequency block shall be attenuated below the transmitter power (P) by at least $43 + 10 \log_{10}(P)$ dB. The limit of emission equal to -13dBm

4.6.2 TEST INSTRUMENTS

DESCRIPTION & MANUFACTURER	MODEL NO.	SERIAL NO.	DATE OF CALIBRATION	DUE DATE OF CALIBRATION
* ROHDE & SCHWARZ Spectrum Analyzer	FSP40	100039	Feb. 03, 2012	Feb. 02, 2013
* Wainwright Instruments Band Reject Filter	WRCG 1710/1785-1690/18 05-60/12SS	SN1	Oct. 28, 2011	Oct. 27, 2012
* Wainwright Instruments High Pass Filter	WHK3.1/18G-10SS	SN3	Jun. 14, 2011	Jun. 13, 2012
* Mini-Circuits Power Splitter	ZAPD-4	NA	Mar. 24, 2011	Mar. 23, 2012
* Hewlett Packard RF cable	8120-6192	274388	Oct. 22, 2011	Oct. 21, 2012
* JFW 20dB attenuation	50HF-020-SMA	NA	NA	NA
* Suhner RF cable	Sucoflex104	274403/4	Aug. 20, 2011	Aug. 19, 2012

- NOTE:**
1. The calibration interval of the above test instruments is 12 months. And the calibrations are traceable to NML/ROC and NIST/USA.
 2. "*" = These equipments are used for the final measurement.

4.6.3 TEST PROCEDURE

- a. The EUT was set up for the maximum peak power with WCDMA link data modulation. The power was measured with R&S Spectrum Analyzer. All measurements were done at 1 channel (middle operational frequency.).
- b. The conducted spurious emission used the power splitter via EUT RF power connector between simulation base station and spectrum analyzer.
- c. When the spectrum scanned from 30MHz to 17.6GHz, it shall be connected to the band reject filter attenuated the carried frequency. The spectrum set RB=1MHz, VB=3MHz.

4.6.4 TEST SETUP

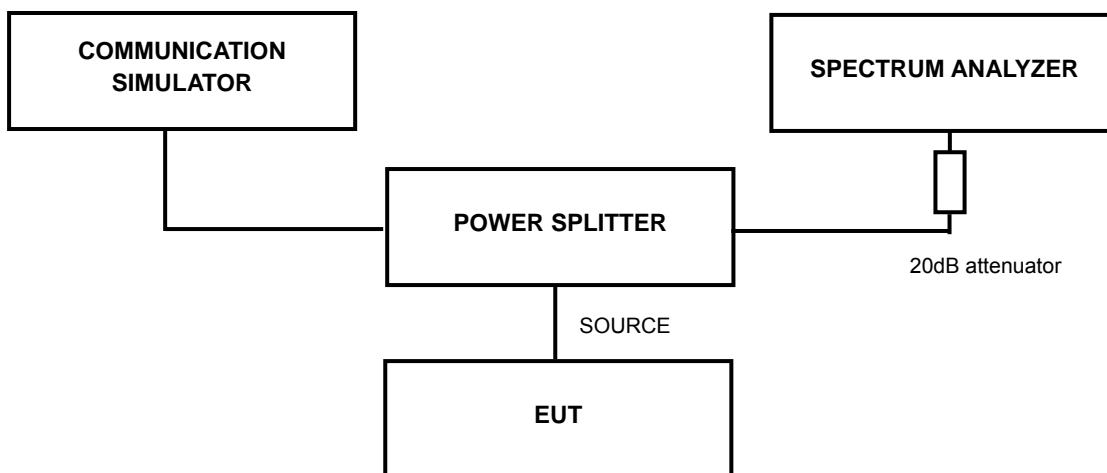

4.6.5 EUT OPERATING CONDITIONS

- a. The EUT makes a phone call to the communication simulator.
- b. The communication simulator station system controlled a EUT to export maximum output power under transmission mode and specific channel frequency.



A D T

4.6.6 TEST RESULTS

CH 1413: 30MHz ~ 1GHz

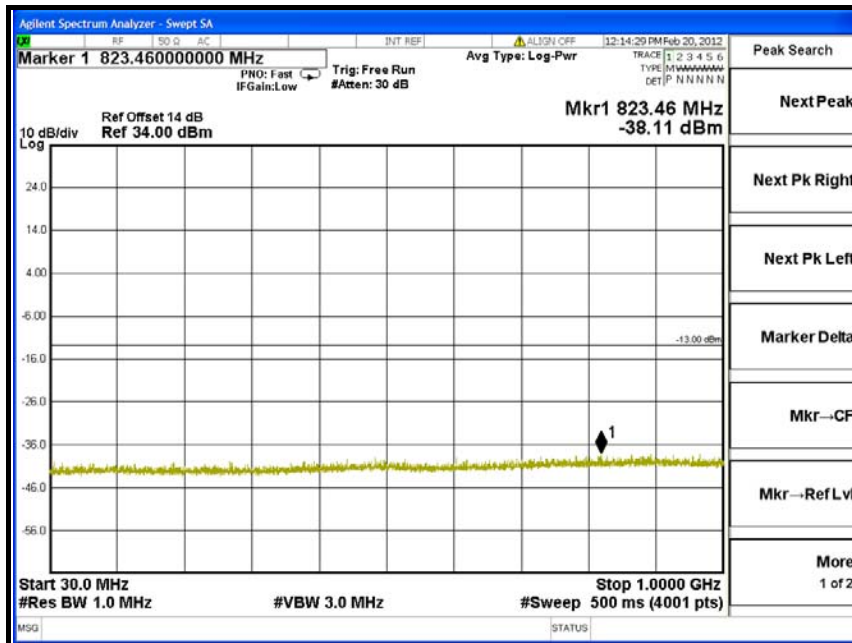

1GHz ~ 3GHz

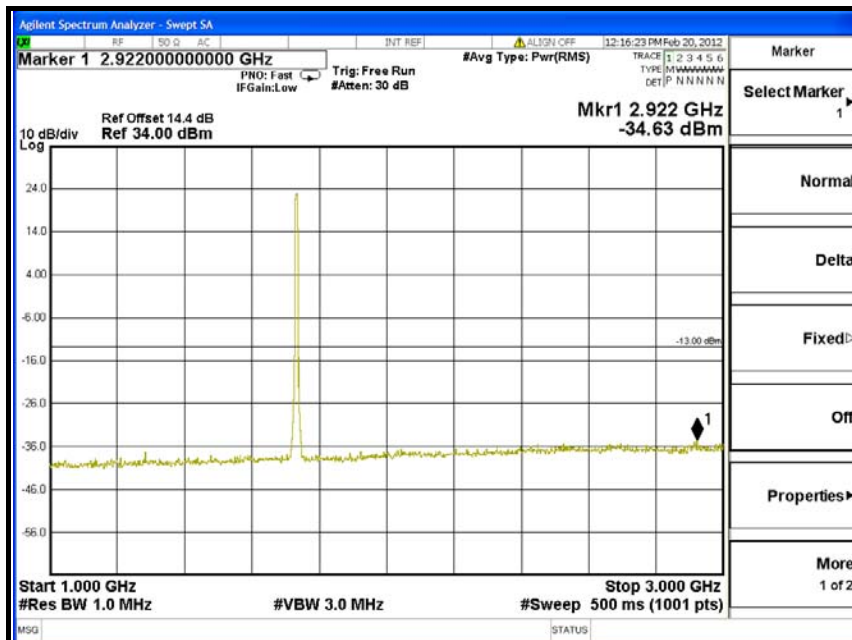



A D T

3GHz ~ 7GHz

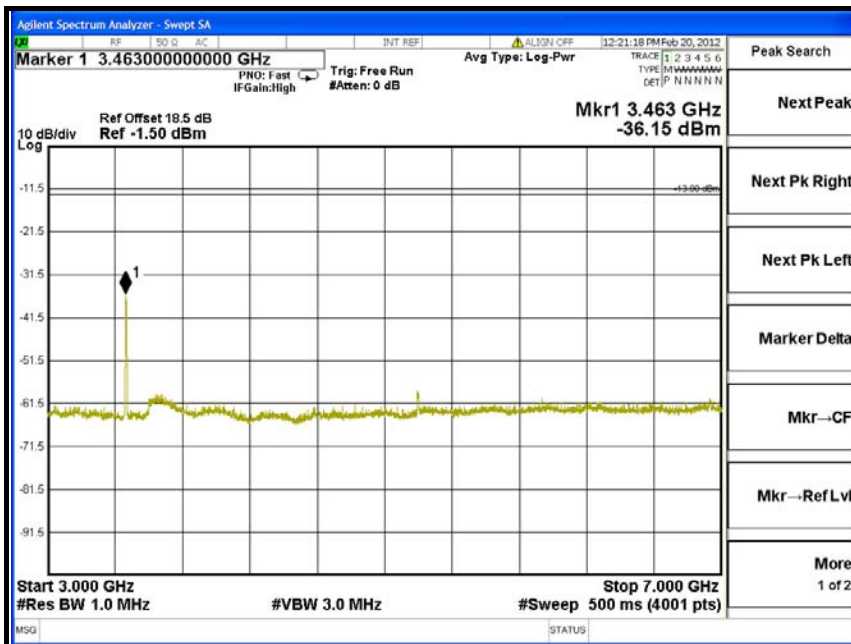

7GHz ~ 13.6GHz

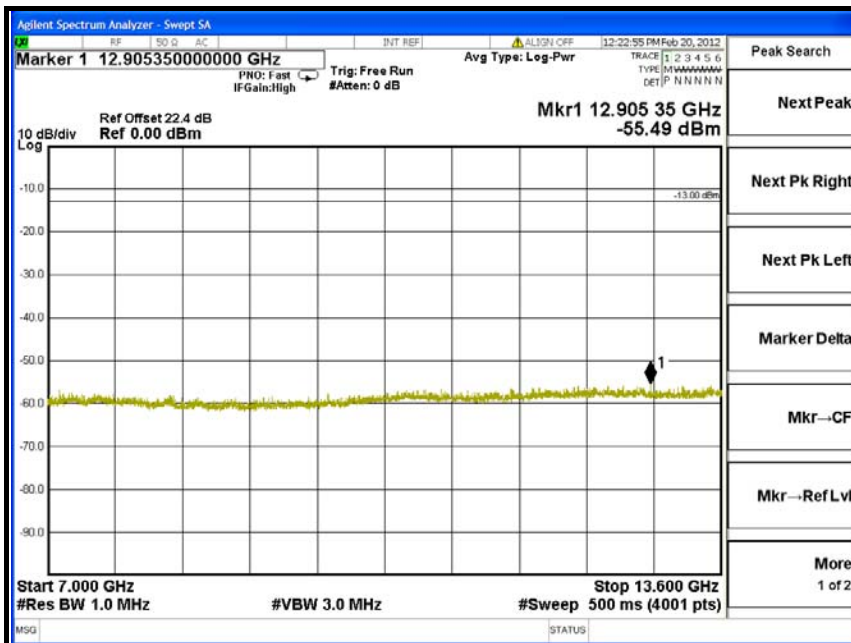



A D T

13.6GHz ~ 17.6GHz

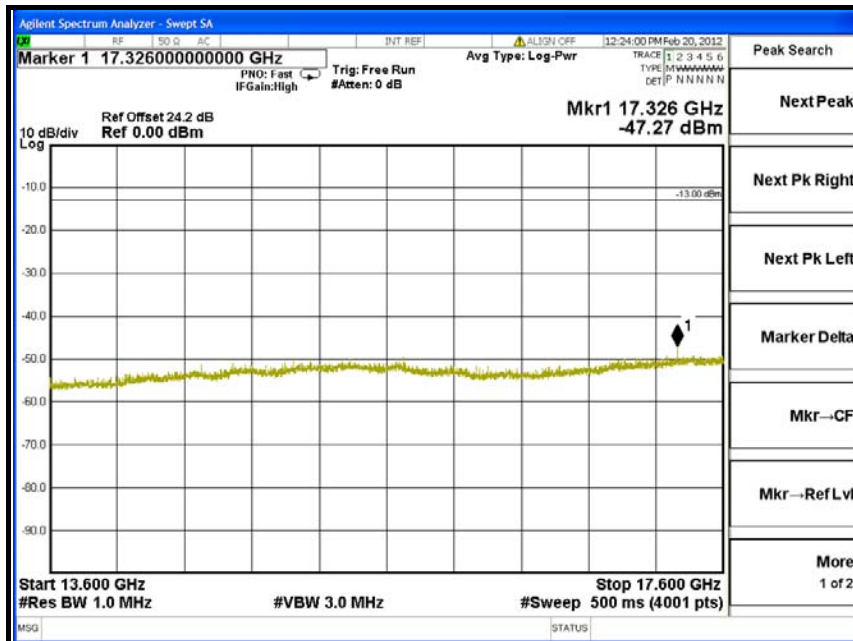

4.7 RADIATED EMISSION MEASUREMENT

4.7.1 LIMITS OF RADIATED EMISSION MEASUREMENT

The power of any emission outside a licensee's frequency block shall be attenuated below the transmitter power (P) by at least $43 + 10 \log_{10}(P)$ dB. The limit of emission equal to -13dBm

So the limit of emission is the same absolute specified line.

LIMIT (dBm)	EQUIVALENT FIELD STRENGTH AT 3m (dBuV/m) (NOTE)
-13	82.22

NOTE: The following formula is used to convert the equipment radiated power to field strength.

$$E = [1000000 \sqrt{(30P)}] / 3 \text{ uV/m, where P is Watts.}$$

4.7.2 TEST INSTRUMENTS

DESCRIPTION & MANUFACTURER	MODEL NO.	SERIAL NO.	DATE OF CALIBRATION	DUE DATE OF CALIBRATION
Test Receiver Agilent	N9038A	MY51210203	Dec. 22, 2011	Dec. 21, 2012
Spectrum Analyzer ROHDE & SCHWARZ	FSU43	101261	Dec. 21, 2011	Dec. 20, 2012
BILOG Antenna SCHWARZBECK	VULB9168	9168-472	Dec. 20, 2011	Dec. 19, 2012
HORN Antenna SCHWARZBECK	BBHA 9120 D	9120D-969	Dec. 20, 2011	Dec. 19, 2012
HORN Antenna SCHWARZBECK	BBHA 9170	9170-480	Dec. 20, 2011	Dec. 19, 2012
Preamplifier EMCI	EMC 012645	980115	Dec. 30, 2011	Dec. 29, 2012
Preamplifier EMCI	EMC 330H	980112	Dec. 30, 2011	Dec. 29, 2012
RF signal cable HUBER+SUHNNER	SUCOFLEX 104	309219/4	Oct. 21, 2011	Oct. 20, 2012
RF signal cable HUBER+SUHNNER	SUCOFLEX 104	250130/4	Jan. 02, 2012	Jan. 01, 2013
RF signal cable Worken	RG-213	NA	Jan. 02, 2012	Jan. 01, 2013
Software	E3 6.120103	NA	NA	NA
Antenna Tower MF	MFA-440H	NA	NA	NA
Turn Table MF	MFT-201SS	NA	NA	NA
Antenna Tower & Turn Table Controller MF	MF-7802	NA	NA	NA

- NOTE:**
1. The calibration interval of the above test instruments is 12 months and the calibrations are traceable to NML/ROC and NIST/USA.
 2. The test was performed in HwaYa Chamber 9.
 3. The horn antenna and HP preamplifier (model: 8449B) are used only for the measurement of emission frequency above 1GHz if tested.
 4. The FCC Site Registration No. is 460141.
 5. The IC Site Registration No. is IC 7450F-4.

4.7.3 TEST PROCEDURES

- a. The EUT was placed on the top of a rotating table 0.8 meters above the ground. The table was rotated 360 degrees to determine the position of the highest radiation.
- b. The EUT was set 3 meters away from the receiving antenna, which was mounted on antenna tower and its position at 0.8 m above the ground.
- c. For each suspected emission, the EUT was arranged to its worst case and the rotatable table was turned from 0 degrees to 360 degrees to find the maximum reading and recorded the value.
- d. Repeat step a ~ c for horizontal polarization.

NOTE: The resolution bandwidth of spectrum analyzer is 1 MHz and the video bandwidth is 3 MHz.

4.7.4 DEVIATION FROM TEST STANDARD

No deviation

4.7.5 TEST SETUP

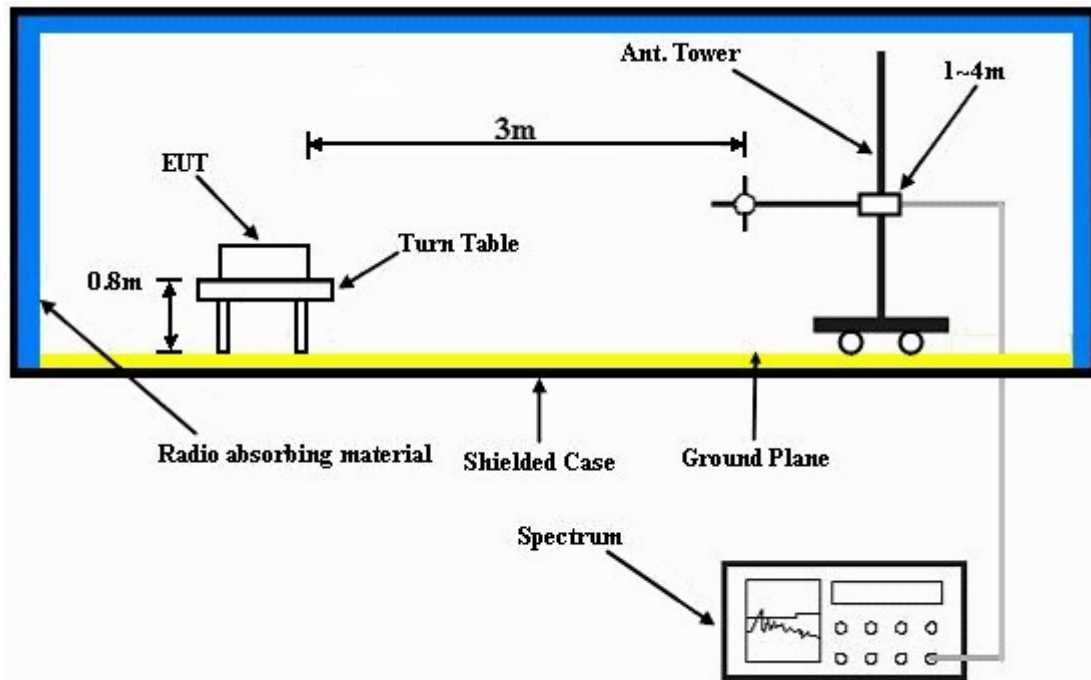

For the actual test configuration, please refer to the attached file (Test Setup Photo).

4.7.6 EUT OPERATING CONDITIONS

- a. The EUT makes a call to the communication simulator.
- b. The communication simulator station system controlled an EUT to export maximum output power under transmission mode and specific channel frequency.



4.7.7 TEST RESULTS

ENVIRONMENTAL CONDITIONS	25deg. C, 57%RH	INPUT POWER	120Vac, 60 Hz
TESTED BY	David Huang	POLARIZATION	Horizontal
TEST MODE	A		

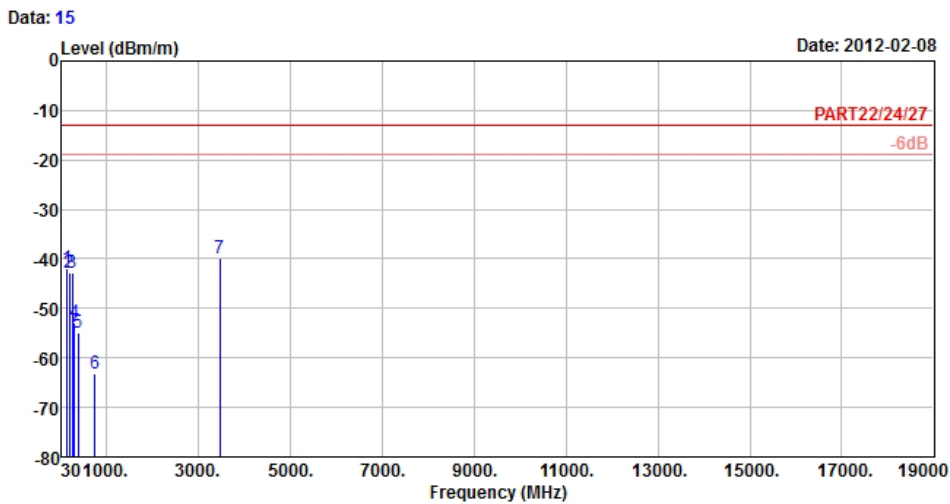

Site : 966 Chamber 5
 Condition : PART22/24/27 3m EIRP_RSE _1G~19G HORIZONTAL
 Brand/Model: PJ40110
 Remark : Band IV CH1413 Link
 Tested by : David Huang
 Temperature : 25°C
 Humidity : 65%
 Plane : X

	Freq	Level	Read Level	Limit Line	Over Limit	Factor	Remark
	MHz	dBm/m	dBm	dBm/m	dB	dB/m	
1	138.54	-41.85	-35.92	-13.00	-28.85	-5.93	Peak
2	192.00	-42.68	-35.64	-13.00	-29.68	-7.04	Peak
3	258.15	-42.72	-36.93	-13.00	-29.72	-5.79	Peak
4	303.50	-52.86	-46.51	-13.00	-39.86	-6.35	Peak
5	391.70	-55.03	-49.33	-13.00	-42.03	-5.70	Peak
6	744.50	-63.15	-64.90	-13.00	-50.15	1.75	Peak
7 pp	3465.20	-39.83	-39.83	-13.00	-26.83	0.00	Peak



A D T

ENVIRONMENTAL CONDITIONS	25deg. C, 57%RH	INPUT POWER	120Vac, 60 Hz
TESTED BY	David Huang	POLARIZATION	Vertical
TEST MODE	A		

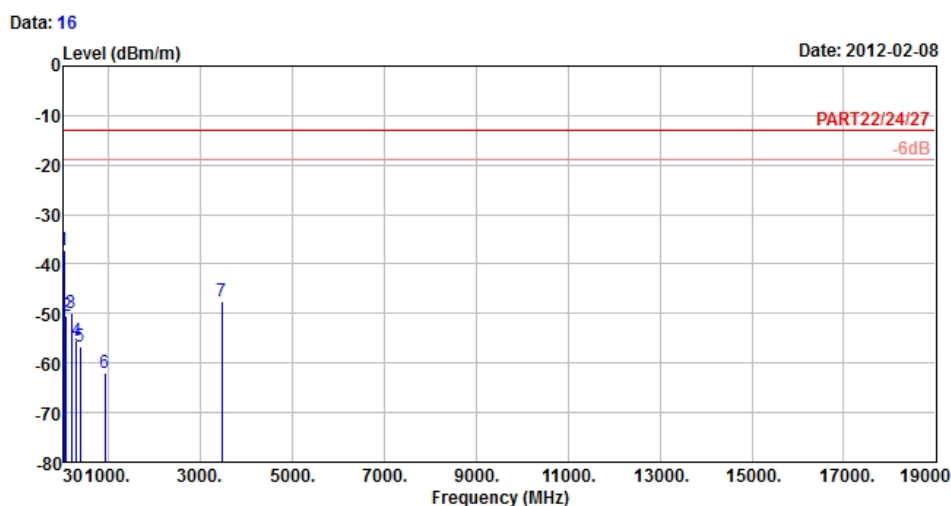

Site : 966 Chamber 5
 Condition : PART22/24/27 3m EIRP_RSE_1G~19G VERTICAL
 Brand/Model: PJ40110
 Remark : Band IV CH1413 Link
 Tested by : David Huang
 Temperature : 25°C
 Humidity : 65%
 Plane : X

	Read	Limit	Over			
Freq	Level	Level	Line	Limit	Factor	Remark
MHz	dBm/m	dBm	dBm/m	dB	dB/m	
1 pp	30.00	-37.18	-38.25	-13.00	-24.18	1.07 Peak
2	90.21	-50.51	-39.93	-13.00	-37.51	-10.58 Peak
3	191.19	-49.96	-43.04	-13.00	-36.96	-6.92 Peak
4	300.00	-55.56	-49.18	-13.00	-42.56	-6.38 Peak
5	388.20	-56.75	-51.02	-13.00	-43.75	-5.73 Peak
6	930.70	-61.98	-65.29	-13.00	-48.98	3.31 Peak
7	3465.20	-47.61	-47.61	-13.00	-34.61	0.00 Peak



ENVIRONMENTAL CONDITIONS	25deg. C, 57%RH	INPUT POWER	120Vac, 60 Hz
TESTED BY	David Huang	POLARIZATION	Horizontal
TEST MODE	B		

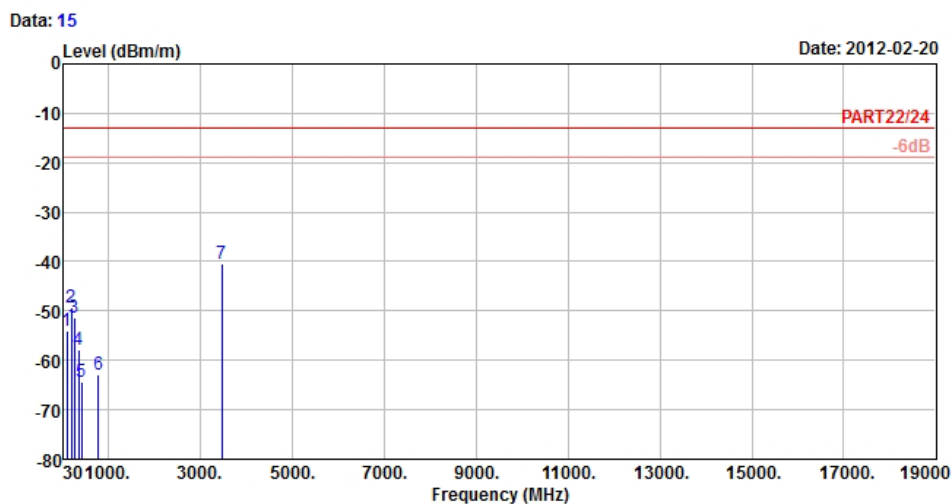

Site : 966 Chamber 5
 Condition : PART22/24 3m EIRP_RSE_1G~19G HORIZONTAL
 Brand/Model: PJ40110
 Remark : Band IV Link
 Tested by : Kay Wu
 Temperature : 25°C
 Humidity : 65%
 Plane : X

	Freq	Level	Read	Limit	Over		
	MHz	dBm/m	Level	Line	Limit	Factor	Remark
			dBm	dBm/m	dB	dB/m	
1	91.29	-53.94	-43.38	-13.00	-40.94	-10.56	Peak
2	189.84	-49.17	-42.36	-13.00	-36.17	-6.81	Peak
3	251.94	-51.33	-45.62	-13.00	-38.33	-5.71	Peak
4	351.80	-57.87	-51.88	-13.00	-44.87	-5.99	Peak
5	422.50	-64.30	-59.25	-13.00	-51.30	-5.05	Peak
6	774.60	-62.80	-64.76	-13.00	-49.80	1.96	Peak
7 pp	3465.20	-40.47	-31.55	-13.00	-27.47	-8.92	Peak



A D T

ENVIRONMENTAL CONDITIONS	25deg. C, 57%RH	INPUT POWER	120Vac, 60 Hz
TESTED BY	David Huang	POLARIZATION	Vertical
TEST MODE	B		

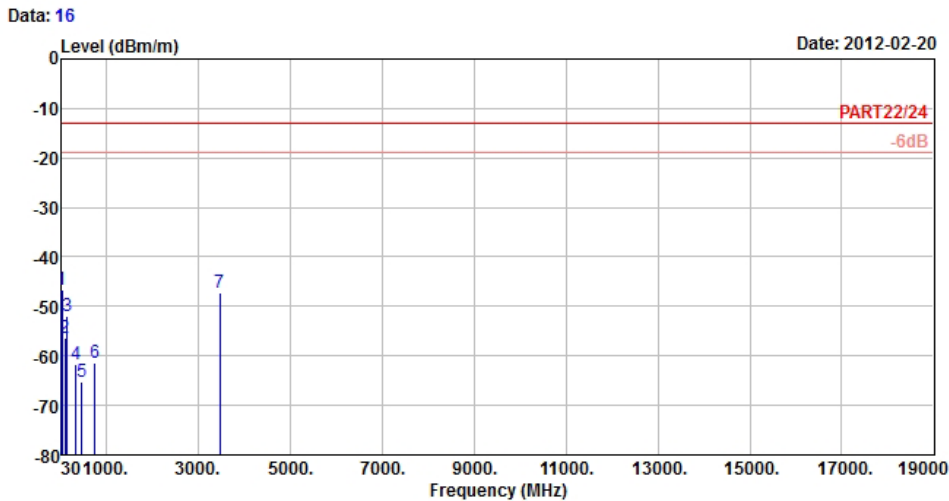

Site : 966 Chamber 5
 Condition : PART22/24 3m EIRP_RSE_1G~19G VERTICAL
 Brand/Model: PJ40110
 Remark : Band IV Link
 Tested by : Kay Wu
 Temperature : 25°C
 Humidity : 65%
 Plane : X

	Read	Limit	Over			
Freq	Level	Level	Line	Limit	Factor	Remark
MHz	dBm/m	dBm	dBm/m	dB	dB/m	
1 pp	42.15	-46.58	-45.25	-13.00	-33.58	-1.33 Peak
2	91.02	-56.45	-45.89	-13.00	-43.45	-10.56 Peak
3	141.78	-52.04	-46.24	-13.00	-39.04	-5.80 Peak
4	344.10	-61.80	-55.75	-13.00	-48.80	-6.05 Peak
5	459.60	-65.36	-61.24	-13.00	-52.36	-4.12 Peak
6	755.00	-61.43	-63.25	-13.00	-48.43	1.82 Peak
7	3465.20	-47.24	-38.32	-13.00	-34.24	-8.92 Peak



5 INFORMATION ON THE TESTING LABORATORIES

We, Bureau Veritas Consumer Products Services (H.K.) Ltd., Taoyuan Branch, were founded in 1988 to provide our best service in EMC, Radio, Telecom and Safety consultation. Our laboratories are accredited and approved according to ISO/IEC 17025.

Copies of accreditation and authorization certificates of our laboratories obtained from approval agencies can be downloaded from our web site: www.adt.com.tw/index.5.phtml. If you have any comments, please feel free to contact us at the following:

Linko EMC/RF Lab:

Tel: 886-2-26052180

Fax: 886-2-26051924

Hsin Chu EMC/RF Lab:

Tel: 886-3-5935343

Fax: 886-3-5935342

Hwa Ya EMC/RF/Safety/Telecom Lab:

Tel: 886-3-3183232

Fax: 886-3-3185050

Email: service.adt@tw.bureauveritas.com

Web Site: www.adt.com.tw

The address and road map of all our labs can be found in our web site also.

6 APPENDIX A – MODIFICATIONS RECORDERS FOR ENGINEERING CHANGES TO THE EUT BY THE LAB

No modifications were made to the EUT by the lab during the test.

---END---