

## FCC 47 CFR PART 22H and 24E

Product Type : Smartphone

Applicant : HTC Corporation

Address : No. 23, Xinghua Rd., Taoyuan City, Taoyuan County 330, Taiwan

Trade Name : HTC

Model Number : PJ03120

Test Specification : FCC 47 CFR PART 22H: Oct, 2009  
FCC 47 CFR PART 24E: Oct, 2009  
CANADA RSS-132 ISSUE 2: Sep., 2005  
CANADA RSS-133 ISSUE 5: Feb., 2009  
ANSI/TIA-603-C-2004

Application Purpose: : Original

Receive Date : Sep. 06, 2011

Issue Date : Oct. 11, 2011

### Issue by

A Test Lab Techno Corp.  
No. 140-1, Changan Street, Bade City,  
Taoyuan County 334, Taiwan R.O.C.  
Tel : +886-3-2710188 / Fax : +886-3-2710190



Taiwan Accreditation Foundation accreditation number: 1330

**Note:** This report shall not be reproduced except in full, without the written approval of A Test Lab Techno Corp. This document may be altered or revised by A Test Lab Techno Corp. personnel only, and shall be noted in the revision section of the document. The client should not use it to claim product endorsement by TAF, or any government agencies. The test results in the report only apply to the tested sample.

**Revision History**

<b>Rev.</b>	<b>Issue Date</b>	<b>Revisions</b>	<b>Revised By</b>
00	Oct. 11, 2011	Initial Issue	

## Verification of Compliance

Issued Date: 10/11/2011

Product Type : Smartphone  
Applicant : HTC Corporation  
Address : No. 23, Xinghua Rd., Taoyuan City, Taoyuan County 330,  
Taiwan  
Trade Name : HTC  
Model Number : PJ03120  
FCC ID : NM8PJ03120  
EUT Rated Voltage : DC 5.0V, 1.0A  
Test Voltage : 120 Vac / 60 Hz  
Applicable : FCC 47 CFR PART 22H: Oct, 2009  
Standard : FCC 47 CFR PART 24E: Oct, 2009  
CANADA RSS-132 ISSUE 2: Sep., 2005  
CANADA RSS-133 ISSUE 5: Feb., 2009  
ANSI/TIA-603-C-2004  
Application : Original  
Purpose  
Test Result : Complied  
Performing Lab. : A Test Lab Techno Corp.

No. 140-1, Changan Street, Bade City  
Taoyuan County 334, Taiwan R.O.C.

Tel : +886-3-2710188 / Fax : +886-3-2710190

Taiwan Accreditation Foundation accreditation number:  
1330

<http://www.atl-lab.com.tw/e-index.htm>



The above equipment was tested by A Test Lab Techno Corp. The test data, data evaluation, test procedures, and equipment configurations shown in this report were made in accordance with the procedures given in ANSI C63.4: 2009 and the energy emitted by the sample tested as described in this report is in compliance with the requirements of FCC Rules Part 22H, Part 24E.

The test results of this report relate only to the tested sample identified in this report.

Approved By :   
(Manager) (Miller Lee)

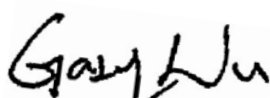
Reviewed By :   
(Testing Engineer) (Gary Wu)

## TABLE OF CONTENTS

<b>1</b>	<b>General Information .....</b>	<b>6</b>
1.1.	EUT Description.....	6
1.2.	Mode of Operation.....	7
1.3.	EUT Exercise Software.....	7
1.4.	Configuration of Test System Details.....	8
1.5.	Test Site Environment.....	8
1.6.	Summary of Test Result .....	9
<b>2</b>	<b>RF Output Power Test.....</b>	<b>10</b>
2.1.	Limit .....	10
2.2.	Test Instruments .....	10
2.3.	Test Setup.....	10
2.4.	Test Procedure.....	10
2.5.	Uncertainty.....	11
2.6.	Test Result.....	11
<b>3</b>	<b>Effective Radiated Power / Equivalent Isotropic Radiated Power Test .....</b>	<b>13</b>
3.1.	Limit .....	13
3.2.	Test Instruments .....	13
3.3.	Setup .....	14
3.4.	Test Procedure.....	15
3.5.	Uncertainty.....	15
3.6.	Test Result.....	16
<b>4</b>	<b>Occupied Bandwidth Test .....</b>	<b>18</b>
4.1.	Limit .....	18
4.2.	Test Instruments .....	18
4.3.	Setup .....	18
4.4.	Test Procedure.....	19
4.5.	Uncertainty.....	19
4.6.	Test Result.....	20
<b>5</b>	<b>Conducted Emission Test .....</b>	<b>36</b>
5.1.	Limit .....	36
5.2.	Test Instruments .....	36
5.3.	Setup .....	36
5.4.	Test Procedure.....	37
5.5.	Uncertainty.....	37
5.6.	Test Result.....	37

<b>6</b>	<b>Field Strength of Spurious Radiation Test .....</b>	<b>92</b>
6.1.	Limit .....	92
6.2.	Test Instruments .....	92
6.3.	Setup .....	93
6.4.	Test Procedure.....	93
6.5.	Uncertainty.....	94
6.6.	Test Result.....	95
<b>7</b>	<b>Frequency Stability (Temperature Variation) Test.....</b>	<b>107</b>
7.1.	Limit .....	107
7.2.	Test Instruments .....	107
7.3.	Setup .....	107
7.4.	Test Procedure.....	108
7.5.	Uncertainty.....	108
7.6.	Test Result.....	108
<b>8</b>	<b>Frequency Stability (Voltage Variation) Test.....</b>	<b>111</b>
8.1.	Limit .....	111
8.2.	Test Instruments .....	111
8.3.	Setup .....	111
8.4.	Test Procedure.....	111
8.5.	Uncertainty.....	112
8.6.	Test Result.....	112
<b>9</b>	<b>AC Power Conducted Emissions Test .....</b>	<b>114</b>
9.1.	Limit .....	114
9.2.	Test Instruments .....	114
9.3.	Setup .....	114
9.4.	Test Procedure.....	115
9.5.	Uncertainty.....	115
9.6.	Test Result.....	116

# 1 General Information

## 1.1. EUT Description

Applicant		HTC Corporation			
Applicant Address		No. 23, Xinghua Rd., Taoyuan City, Taoyuan County 330, Taiwan			
Manufacturer		HTC Corporation			
Manufacturer Address		No. 23, Xinghua Rd., Taoyuan City, Taoyuan County 330, Taiwan			
Product Type		Smartphone			
Trade Name		HTC			
Model Number		PJ03120			
FCC ID		NM8PJ03120			
IMEI No.		358703040010933			
Mode	GSM/GPRS/ EGPRS	Band	UL Frequency (MHz)	DL Frequency (MHz)	Modulation
		850	824.2 ~ 848.8	869.2 ~ 893.8	GMSK/8PSK
	WCDMA/ HSDPA/ HSUPA	1900	1850.2 ~ 1909.8	1930.2 ~ 1989.8	GMSK/8PSK
		Band	UL Frequency (MHz)	DL Frequency (MHz)	Modulation
		II	1852.4 ~ 1907.6	1932.4 ~ 1987.6	QPSK
V	826.4 ~ 846.6	871.4 ~ 891.6	QPSK		
Channel Control		Auto			
Type of Antenna		PIFA Type			
Antenna Gain (dBi)		GSM/GPRS/EGPRS 850: -1.86 dBi GSM/GPRS/EGPRS 1900: -0.89 dBi WCDMA/ HSDPA/ HSUPA Band II: -0.91 dBi WCDMA/ HSDPA/ HSUPA Band V: -1.90 dBi			
Max. RF Output power		GSM/GPRS 850: 32.32 dBm / 1.706 W, EGPRS 850: 30.34 dBm / 1.081 W GSM/GPRS 1900: 30.48 dBm / 1.117 W, EGPRS 1900: 29.52 dBm / 0.895 W WCDMA/ HSDPA/ HSUPA Band II: 26.60 dBm / 0.457 W WCDMA/ HSDPA/ HSUPA Band V: 26.59 dBm / 0.456 W			
Max. ERP/EIRP		GSM/GPRS 850: 28.89 dBm / 0.774 W, EGPRS 850: 23.86 dBm / 0.243 W GSM/GPRS 1900: 26.12 dBm / 0.409 W, EGPRS 1900: 24.35 dBm / 0.272 W WCDMA/ HSDPA/ HSUPA Band II: 22.92 dBm / 0.196 W WCDMA/ HSDPA/ HSUPA Band V: 24.61 dBm / 0.289 W			
Emission Designator		GSM/GPRS 850: 249KGXW, EGPRS 850: 243KG7W GSM/GPRS 1900: 248KGXW, EGPRS 1900: 242KG7W WCDMA/ HSDPA Band II: 4M17F9W WCDMA/ HSDPA Band V: 4M17F9W			

## 1.2. Mode of Operation

ATL has verified the construction and function in typical operation. All the test modes were carried out with the EUT in normal operation, which was shown in this test report and defined as:

Test Mode
Mode 1: GSM 850 Link
Mode 2: GSM 1900 Link
Mode 3: WCDMA Band II Link
Mode 4: WCDMA Band V Link
Mode 5: EGPRS 850 Link
Mode 6: EGPRS 1900 Link

Note: Regards to the frequency band operation: the lowest, middle and highest frequency of channel were selected to perform the test, then shown on this report.

By preliminary testing and verifying three axis (X, Y and Z) position of EUT transmitted status, it was found that "X axis" position was the worst, then the final test was executed the worst condition and test data were recorded in this report.

### Tested System Details

The types for all equipments, plus descriptions of all cables used in the tested system (including inserted cards) are:

	Product	Manufacturer	Model Number	Serial Number	Power Cord
1.	Universal Radio Communication Tester	R&S	CMU200	109369	N/A

## 1.3. EUT Exercise Software

1.	Setup the EUT and Base Station (CMU200) as shown on 1.4.
2.	Turn on the power of all equipment.

**1.4. Configuration of Test System Details**

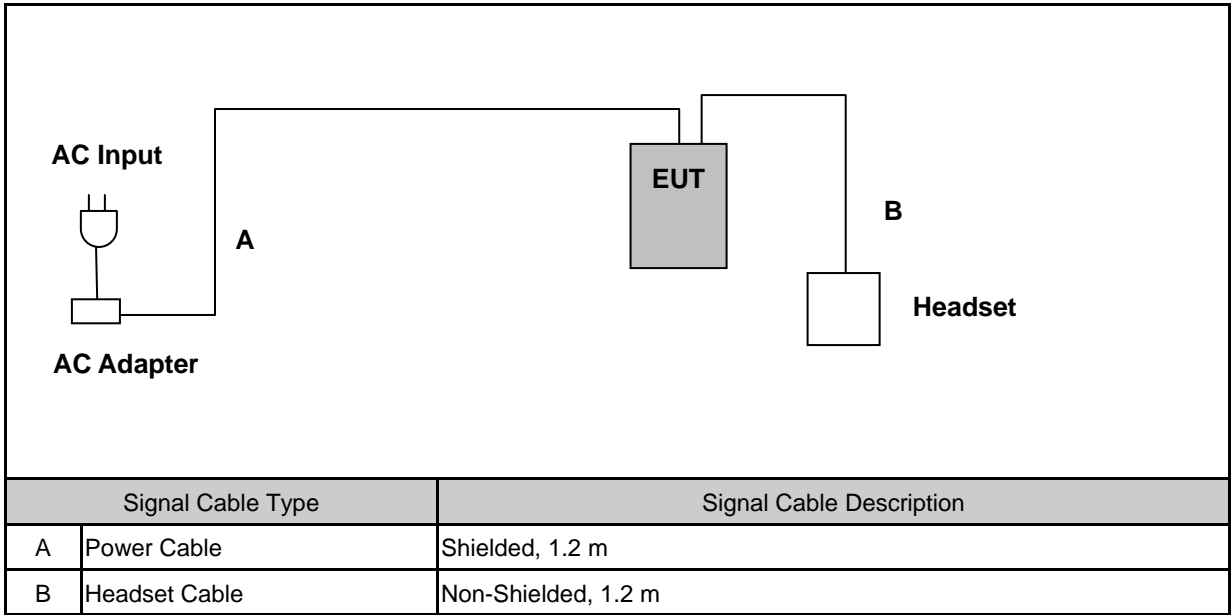

**1.5. Test Site Environment**

Items	Required (IEC 68-1)	Actual
Temperature (°C)	15-35	26
Humidity (%RH)	25-75	60
Barometric pressure (mbar)	860-1060	950



**1.6. Summary of Test Result**

Description	FCC Rule	IC Rule	Limit	Result
Conducted Output Power	§2.1046	N/A	N/A	Pass
Effective Radiated Power	§22.913(a)(2)	RSS-132(4.4) SRSP-503(5.1.3)	< 7 Watts for FCC (<6.3 Watts for IC)	Pass
Equivalent Isotropic Radiated Power	§24.232(c)	RSS-133 (6.4) SRSP-510(5.1.2)	< 2 Watts	Pass
Occupied Bandwidth	§2.1049 §22.917(a) §24.238(a)	N/A	N/A	Pass
Band Edge Measurement	§2.1051 §22.917(a) §24.238(a)	RSS-132 (4.5.1)RSS-133 (6.5.1)	< 43+10log <sub>10</sub> (P[Watts])	Pass
Conducted Emission	§2.1051 §22.917(a) §24.238(a)	RSS-132 (4.5.1) RSS-133 (6.5.1)	< 43+10log <sub>10</sub> (P[Watts])	Pass
Field Strength of Spurious Radiation	§2.1053 §22.917(a) §24.238(a)	RSS-132 (4.5.1) RSS-133 (6.5.1)	< 43+10log <sub>10</sub> (P[Watts])	Pass
Frequency Stability for Temperature & Voltage	§2.1055 §22.355 §24.235	RSS-132(4.3) RSS-133(6.3)	< 2.5 ppm	Pass

## 2 RF Output Power Test

### 2.1. Limit

N/A

### 2.2. Test Instruments

Describe	Manufacturer	Model No.	Serial No.	Cal. Date	Remark
Universal Radio Communication Tester	ROHDE & SCHWARZ	CMU200	109369	08/10/2010	(2)
Single Channel PK Power Sensor	Agilent	N1911A	MY45101619	07/19/2010	(2)
Wideband Power Meter	Agilent	N1921A	MY45241957	07/19/2010	(2)
Test Site	ATL	TE02	TE02	N.C.R.	-----

Remark: <sup>(1)</sup> Calibration period 1 year. <sup>(2)</sup> Calibration period 2 years.

NOTE: N.C.R. = No Calibration Request.

### 2.3. Test Setup

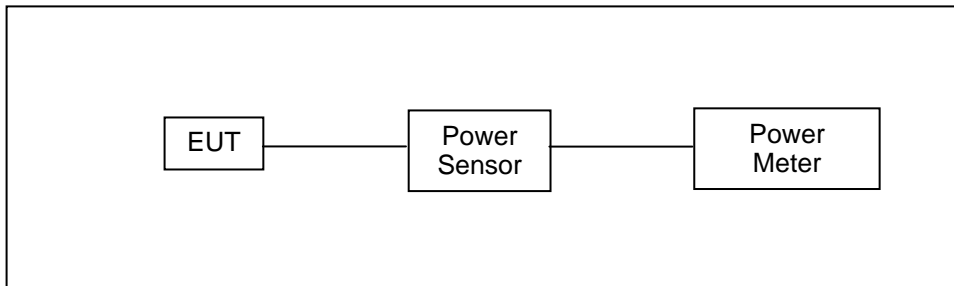

### 2.4. Test Procedure

The measurement is made according to ANSI/TIA-603-C-2004 as follows:

1. The transmitter output was connected to power meter and base station through power divider.
2. Set base station for EUT at GSM 850: PCL=5 and PCS 1900: PCL=0.
3. Set base station for EUT at WCDMA Band V and WCDMA Band II, power level was set to maximum.
4. Select lowest, middle, and highest channels for each band.

## 2.5. Uncertainty

The measurement uncertainty is defined as for RF output power measurement is 1.2 dB.

## 2.6. Test Result

Model Number	PJ03120					
Test Item	RF Output Power					
Date of Test	09/09/2011			Test Site	TE02	
Bands	Data Rate	Frequency (MHz)	Average Power		Peak Power	
			(dBm)	(W)	(dBm)	(W)
GSM 850	-----	824.2	32.22	1.667	<b>32.32</b>	<b>1.706</b>
		836.4	32.20	1.660	32.30	1.698
		848.8	32.10	1.622	32.20	1.660
GRRS 850	4Down1Up	824.2	32.21	1.663	32.31	1.702
		836.4	32.18	1.652	32.28	1.690
		848.8	32.08	1.614	32.18	1.652
	3Down2Up	824.2	32.14	1.637	32.24	1.675
		836.4	32.11	1.626	32.21	1.663
		848.8	32.00	1.585	32.10	1.622
EGPRS 850	4Down1Up	824.2	27.14	0.518	30.34	1.081
		836.4	27.10	0.513	30.30	1.072
		848.8	27.04	0.506	30.24	1.057
	3Down2Up	824.2	25.59	0.362	28.79	0.757
		836.4	25.57	0.361	28.77	0.753
		848.8	25.51	0.356	28.71	0.743
GSM 1900	-----	1850.20	30.27	1.064	30.37	1.089
		1880.00	30.38	1.091	<b>30.48</b>	<b>1.117</b>
		1909.80	30.35	1.084	30.45	1.109
GRRS 1900	4Down1Up	1850.20	30.26	1.062	30.36	1.086
		1880.00	30.37	1.089	30.47	1.114
		1909.80	30.34	1.081	30.44	1.107
	3Down2Up	1850.20	29.74	0.942	29.84	0.964
		1880.00	29.85	0.966	29.95	0.989
		1909.80	29.81	0.957	29.91	0.979
EGPRS 1900	4Down1Up	1850.20	26.17	0.414	29.37	0.865
		1880.00	26.32	0.429	29.52	0.895
		1909.80	26.28	0.425	29.48	0.887
	3Down2Up	1850.20	25.11	0.324	28.31	0.678
		1880.00	25.25	0.335	28.45	0.700
		1909.80	25.24	0.334	28.44	0.698

Note: The peak power testing result was used peak detector.

Model Number	PJ03120					
Test Item	RF Output Power					
Date of Test	09/09/2011			Test Site	TE02	
Bands	Sub-Test	Frequency (MHz)	Average Power		Peak Power	
			(dBm)	(W)	(dBm)	(W)
WCDMA Band II	-----	1852.4	23.14	0.206	26.59	0.456
		1880.0	22.98	0.199	26.43	0.440
		1907.6	23.15	0.207	<b>26.60</b>	<b>0.457</b>
HSDPA Band II	1	1852.4	22.98	0.199	<b>26.48</b>	<b>0.445</b>
		1880.0	22.83	0.192	26.33	0.430
		1907.6	22.93	0.196	26.43	0.440
	2	1852.4	22.87	0.194	26.37	0.434
		1880.0	22.76	0.189	26.26	0.423
		1907.6	22.85	0.193	26.35	0.432
	3	1852.4	21.40	0.138	24.90	0.309
		1880.0	21.21	0.132	24.71	0.296
		1907.6	21.41	0.138	24.91	0.310
	4	1852.4	21.31	0.135	24.81	0.303
		1880.0	21.22	0.132	24.72	0.296
		1907.6	21.42	0.139	24.92	0.310
WCDMA Band V	-----	826.4	23.00	0.200	26.45	0.442
		836.4	23.14	0.206	<b>26.59</b>	<b>0.456</b>
		846.4	23.01	0.200	26.46	0.443
HSDPA Band V	1	826.4	22.85	0.193	26.35	0.432
		836.4	23.04	0.201	<b>26.54</b>	<b>0.451</b>
		846.4	22.77	0.189	26.27	0.424
	2	826.4	22.85	0.193	26.35	0.432
		836.4	22.75	0.188	26.25	0.422
		846.4	22.72	0.187	26.22	0.419
	3	826.4	22.48	0.177	25.98	0.396
		836.4	22.67	0.185	26.17	0.414
		846.4	22.38	0.173	25.88	0.387
	4	826.4	22.44	0.175	25.94	0.393
		836.4	22.65	0.184	26.15	0.412
		846.4	22.37	0.173	25.87	0.386

Note: The peak power testing result was used peak detector.

### 3 Effective Radiated Power / Equivalent Isotropic Radiated Power Test

#### 3.1. Limit

For FCC Part 22.913(a)(2): The ERP of mobile transmitters and auxiliary test transmitters must not exceed 7 Watts.

For FCC Part 24.232(b): The EIRP of mobile transmitters and auxiliary test transmitters must not exceed 2 Watts.

#### 3.2. Test Instruments

3 Meter Chamber					
Equipment	Manufacturer	Model Number	Serial Number	Cal. Date	Remark
RF Pre-selector	Agilent	N9039A	MY46520256	01/18/2011	(2)
Spectrum Analyzer	Agilent	E4446A	MY46180578	01/18/2011	(1)
Pre Amplifier	Agilent	8449B	3008A02237	02/23/2011	(1)
Pre Amplifier	Agilent	8447D	2944A10961	02/23/2011	(1)
Broadband Antenna (30MHz~1GHz)	SCHWARZBECK MESS-ELEKTRONIK	VULB9163	9163-270	07/29/2011	(1)
Horn Antenna (1~18GHz)	SCHWARZBECK MESS-ELEKTRONIK	BBHA9120D	9120D-550	06/29/2011	(1)
Horn Antenna (18~40GHz)	SCHWARZBECK MESS-ELEKTRONIK	BBHA9170	9170-320	06/28/2011	(1)
Test Site	ATL	TE01	888001	12/24/2010	(1)

Remark: <sup>(1)</sup> Calibration period 1 year. <sup>(2)</sup> Calibration period 2 years.

NOTE: N.C.R. = No Calibration Request.

### 3.3. Setup

#### Below 1 GHz

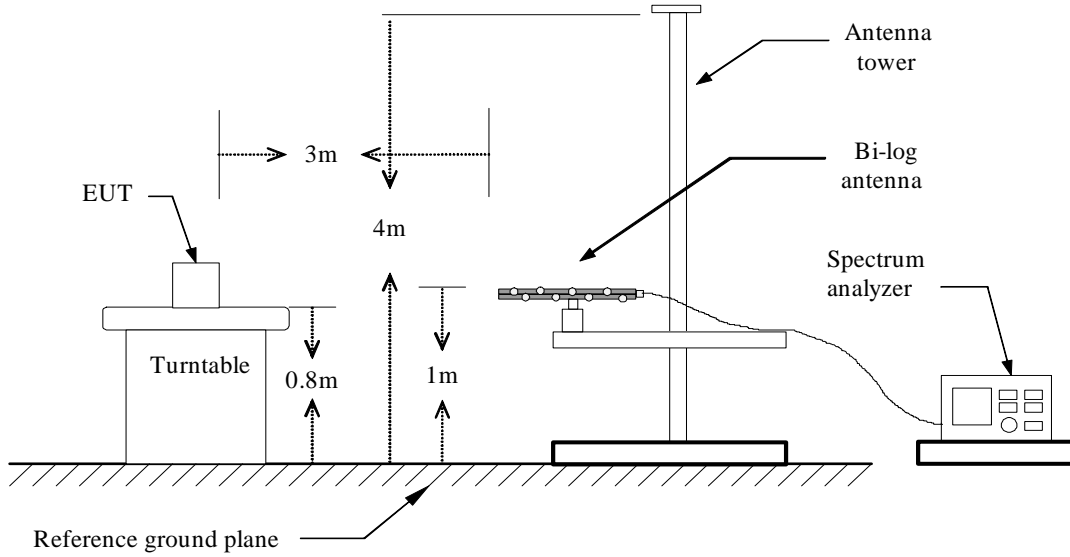

#### Above 1 GHz

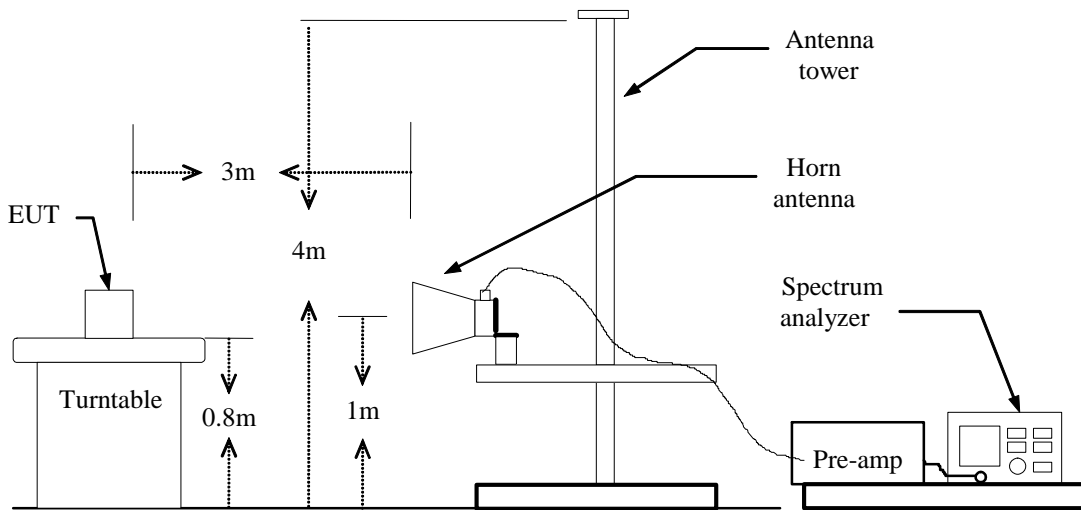

**For Substituted Method Test Set-UP**

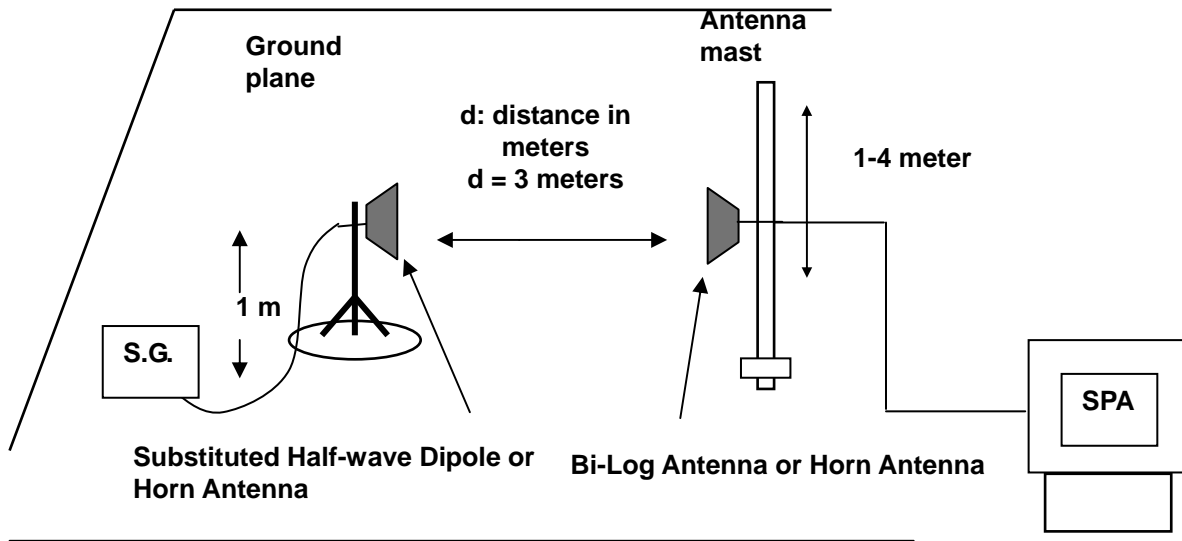

**3.4. Test Procedure**

The measurement is made according to ANSI/TIA-603-C-2004 as follows:

The EUT was placed on a non-conductive turntable using a non-conductive support. The radiated emission at the fundamental frequency was measured at 3 m with a test antenna and EMI spectrum analyzer.

During the measurement of the EUT, the resolution bandwidth was set to 3MHz and the average bandwidth was set to 3MHz. The highest emission was recorded with the rotation of the turntable and the lowering of the test antenna. The reading was recorded and the field strength (E in dBuV/m) was calculated.

ERP in frequency band 824-849MHz, and EIRP in frequency band 1851.25 –1910MHz were measured using a substitution method. The EUT was replaced by half-wave dipole (824-849MHz) or horn antenna (1851.25-1910MHz) connected to a signal generator. The spectrum analyzer reading was recorded and ERP/EIRP was calculated as follows:

$$\text{ERP} = \text{S.G. output (dBm)} + \text{Antenna Gain (dBd)} - \text{Cable (dB)}$$

$$\text{EIRP} = \text{S.G. output (dBm)} + \text{Antenna Gain (dBi)} - \text{Cable (dB)}$$

**3.5. Uncertainty**

The measurement uncertainty is defined as for Field Strength of Spurious Radiation measurement is  $\pm 3.072$  dB.

### 3.6. Test Result

Model Number	PJ03120						
Test Item	ERP/EIRP						
Test Mode	Mode 1: GSM 850 Link						
Date of Test	10/06/2011				Test Site	TE01	
Bands	Frequency (MHz)	Ant. Polar.	Read Level (dBm)	Correction factor (dBm)	ERP		Limit
					(dBm)	(W)	
GSM 850	824.2	H	-16.75	39.19	22.44	0.175	< 7W
		V	-11.83	38.53	26.70	0.468	< 7W
	836.4	H	-15.61	39.30	23.69	0.234	< 7W
		V	-10.76	38.57	27.81	0.604	< 7W
	848.8	H	-14.29	39.71	25.42	0.348	< 7W
		V	-9.79	38.68	<b>28.89</b>	<b>0.774</b>	< 7W
EGPRS 850	824.2	H	-21.72	39.19	17.47	0.056	< 7W
		V	-21.72	39.19	17.47	0.056	< 7W
	836.4	H	-20.66	39.30	18.64	0.073	< 7W
		V	-15.76	38.57	22.81	0.191	< 7W
	848.8	H	-19.28	39.72	20.44	0.111	< 7W
		V	-14.82	38.68	<b>23.86</b>	<b>0.243</b>	< 7W

Model Number	PJ03120						
Test Item	ERP/EIRP						
Test Mode	Mode 2: GSM 1900 Link						
Date of Test	10/06/2011				Test Site	TE01	
Bands	Frequency (MHz)	Ant. Polar.	Read Level (dBm)	Correction factor (dBm)	EIRP		Limit
					(dBm)	(W)	
GSM 1900	1850.20	H	15.30	10.49	25.79	0.379	< 2W
		V	17.43	8.33	25.76	0.377	< 2W
	1880.00	H	15.07	10.51	25.58	0.361	< 2W
		V	17.52	8.57	26.09	0.406	< 2W
	1909.80	H	15.60	10.52	<b>26.12</b>	<b>0.409</b>	< 2W
		V	17.04	8.81	25.85	0.385	< 2W
EGPRS 1900	1850.20	H	12.32	10.49	22.81	0.191	< 2W
		V	15.19	8.33	23.52	0.225	< 2W
	1880.00	H	13.54	10.51	24.05	0.254	< 2W
		V	15.78	8.57	<b>24.35</b>	<b>0.272</b>	< 2W
	1909.80	H	12.71	10.52	23.23	0.210	< 2W
		V	14.97	8.81	23.78	0.239	< 2W

Note: 1. ERP/EIRP = Read Level + Correction factor.

2. For WCDMA signals, a peak detector is used with RBW = VBW = 5MHz.

3. For AMPS, GSM, and NADC TDMA signals, a peak detector is used, with RBW = VBW= 1 MHz.



Model Number	PJ03120						
Test Item	ERP/EIRP						
Test Mode	Mode 3: WCDMA Band II Link						
Date of Test	10/06/2011				Test Site	TE01	
Bands	Frequency (MHz)	Ant. Polar.	Read Level (dBm)	Correction factor (dBm)	EIRP		Limit
					(dBm)	(W)	
WCDMA Band II	1852.4	H	11.39	10.50	21.89	0.155	< 2W
		V	14.56	8.36	<b>22.92</b>	<b>0.196</b>	< 2W
	1880.0	H	11.35	10.51	21.86	0.153	< 2W
		V	14.27	8.58	22.85	0.193	< 2W
	1907.6	H	11.59	10.51	22.10	0.162	< 2W
		V	13.77	8.78	22.55	0.180	< 2W

Model Number	PJ03120						
Test Item	ERP/EIRP						
Test Mode	Mode 4: WCDMA Band V Link						
Date of Test	10/06/2011				Test Site	TE01	
Bands	Frequency (MHz)	Ant. Polar.	Read Level (dBm)	Correction factor (dBm)	ERP		Limit
					(dBm)	(W)	
WCDMA Band V	826.4	H	-19.99	39.21	19.22	0.084	< 7W
		V	-15.38	38.54	23.16	0.207	< 7W
	836.4	H	-20.43	39.31	18.88	0.077	< 7W
		V	-15.77	38.57	22.80	0.191	< 7W
	846.4	H	-18.80	39.64	20.84	0.121	< 7W
		V	-14.03	38.64	<b>24.61</b>	<b>0.289</b>	< 7W

Note: 1. ERP/EIRP = Read Level + Correction factor.

2. For WCDMA signals, a peak detector is used with RBW = VBW = 5MHz.

3. For AMPS, GSM, and NADC TDMA signals, a peak detector is used, with RBW = VBW= 1 MHz.

## 4 Occupied Bandwidth Test

### 4.1. Limit

**The Occupied Bandwidth Limit:**

N/A.

**The Band Edge Limit:**

The power of any emission outside of the authorized operating frequency ranges must be attenuated below the transmitting power (P) by a factor of at least  $43 + 10\log(P)$  dB.

### 4.2. Test Instruments

Describe	Manufacturer	Model No.	Serial No.	Cal. Date	Remark
Spectrum Analyzer	Agilent	E4445A	MY46181986	05/16/2011	(2)
Universal Radio Communication Tester	ROHDE & SCHWARZ	CMU200	109369	08/10/2010	(2)
Attenuator	RADIALL	R41572000	0603033073	N.C.R.	-----
Power divider	Agilent	87302C	3239A00760	N.C.R.	-----
Test Site	ATL	TE02	TE02	N.C.R.	-----

Remark: <sup>(1)</sup> Calibration period 1 year. <sup>(2)</sup> Calibration period 2 years.

NOTE: N.C.R. = No Calibration Request.

### 4.3. Setup

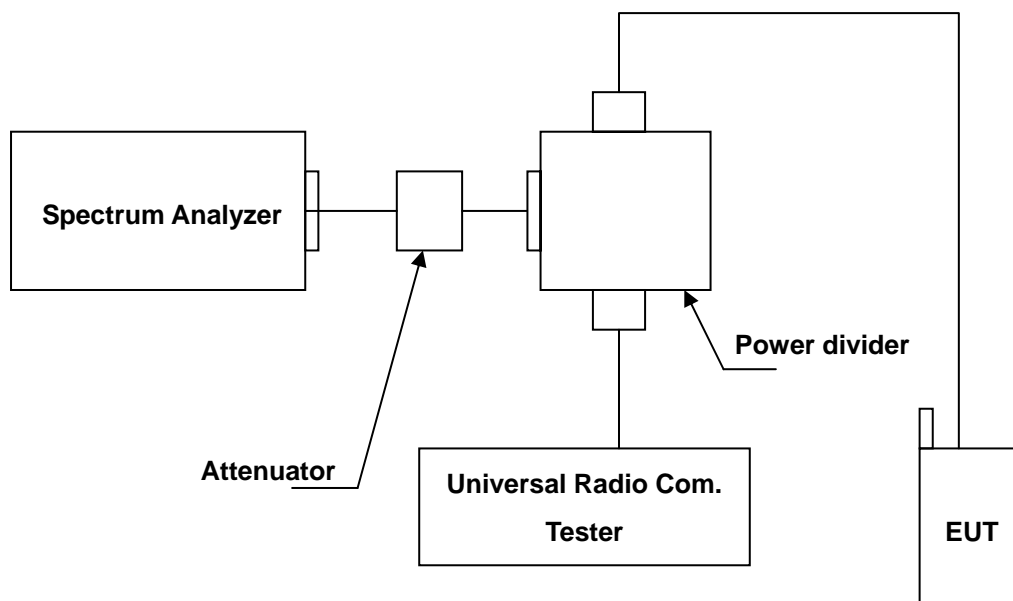

#### 4.4. Test Procedure

The measurement is made according to FCC rules part 22 and 24:

1. The EUT was connected to Spectrum Analyzer and Base Station via power divider.
2. The occupied bandwidth of middle channel for the highest and lowest RF powers was measured.
3. The band edge of low and high channels for the highest RF powers within the transmitting frequency band were measured. Setting RBW as roughly BW/100.
4. The band edge setting:
  - a. RB=10 kHz; VB=30 kHz for GSM 850 and PCS 1900.
  - b. RB=100 kHz; VB=300 kHz for WCDMA Band V and WCDMA Band II.

#### 4.5. Uncertainty

The measurement uncertainty is defined as  $\pm 10\text{Hz}$

**4.6. Test Result**
**99% Occupied Bandwidth**

Model Number	PJ03120		
Test Item	Occupied Bandwidth		
Test Mode	Mode 1: GSM 850 Link		
Date of Test	10/07/2011	Test Site	TE02
Channel No.	Frequency (MHz)	99% Bandwidth (kHz)	Note
128	824.2	244.7694	RBW:10KHz , VBW:30KHz
190	836.4	244.3274	RBW:10KHz , VBW:30KHz
251	848.8	248.7924	RBW:10KHz , VBW:30KHz

**Channel 128**

Channel 190

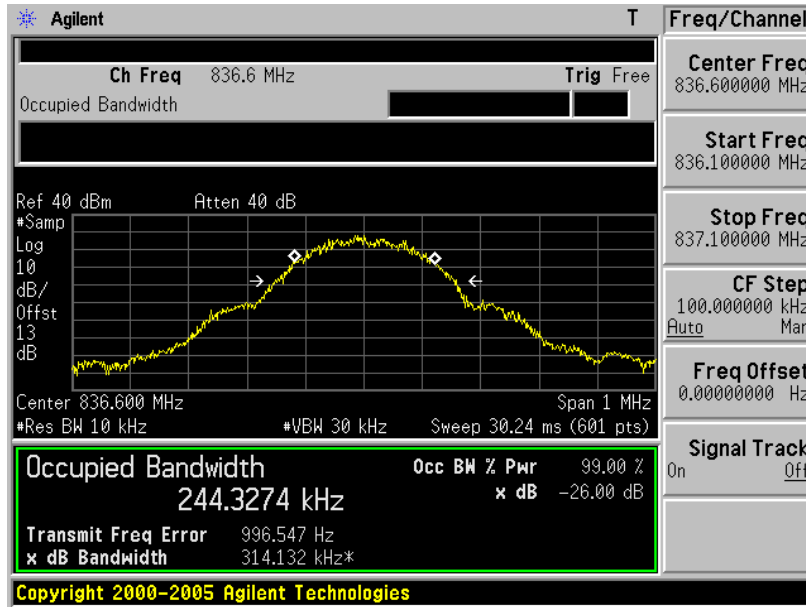

Channel 251

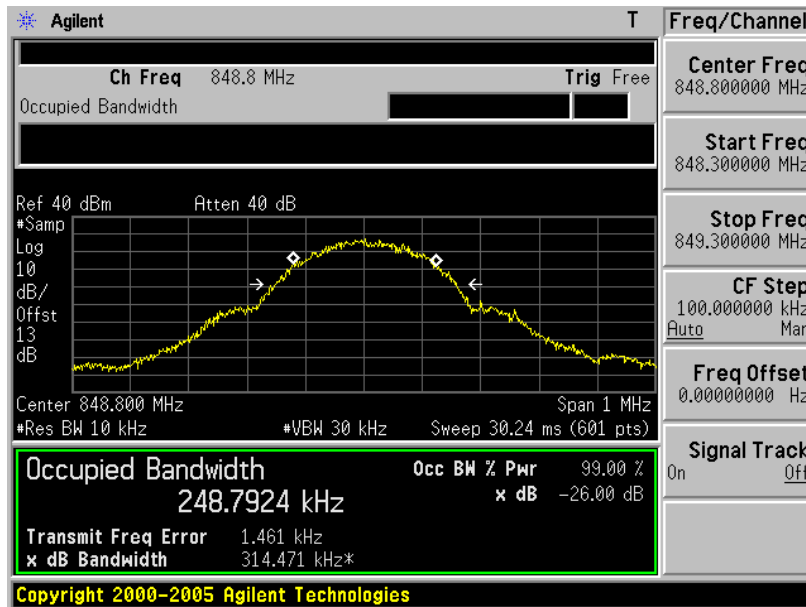

Model Number	PJ03120		
Test Item	Occupied Bandwidth		
Test Mode	Mode 2: GSM 1900 Link		
Date of Test	10/07/2011	Test Site	TE02
Channel No.	Frequency (MHz)	99% Bandwidth (kHz)	Note
512	1850.20	246.4110	RBW:10KHz , VBW:30KHz
661	1880.00	243.1009	RBW:10KHz , VBW:30KHz
810	1909.80	247.8864	RBW:10KHz , VBW:30KHz

## Channel 512

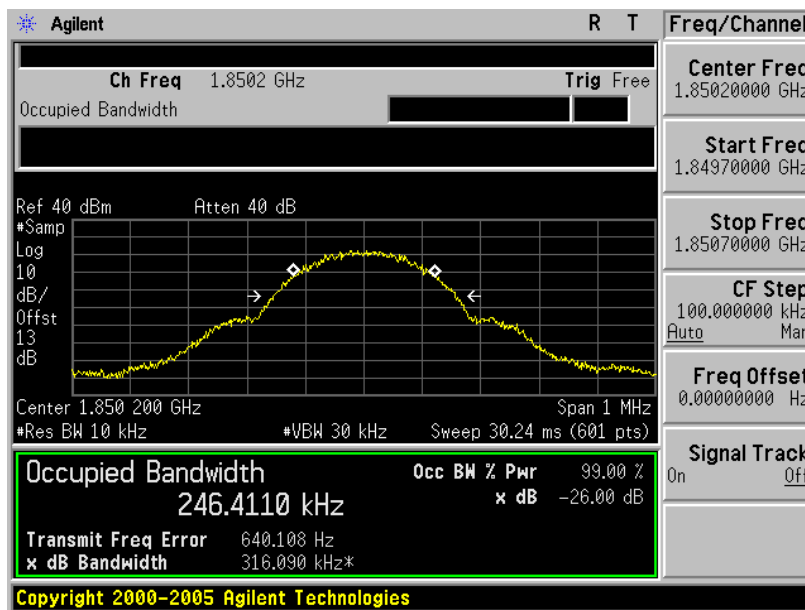

Channel 661

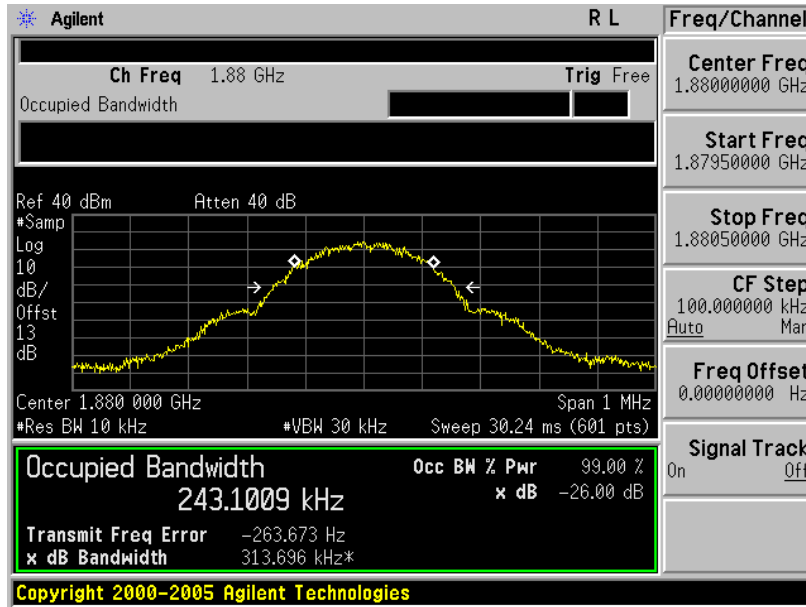

Channel 810

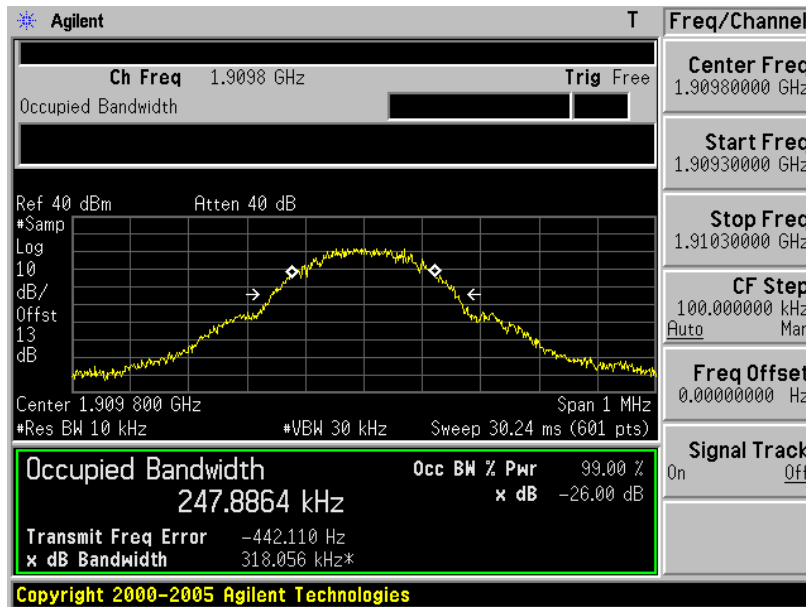

Model Number	PJ03120		
Test Item	Occupied Bandwidth		
Test Mode	Mode 3: WCDMA Band II Link		
Date of Test	10/07/2011	Test Site	TE02
Channel No.	Frequency (MHz)	99% Bandwidth (MHz)	Note
9262	1852.4	4.1645	RBW:100KHz , VBW:300KHz
9400	1880.0	4.1661	RBW:100KHz , VBW:300KHz
9538	1907.6	4.1436	RBW:100KHz , VBW:300KHz

## Channel 9262

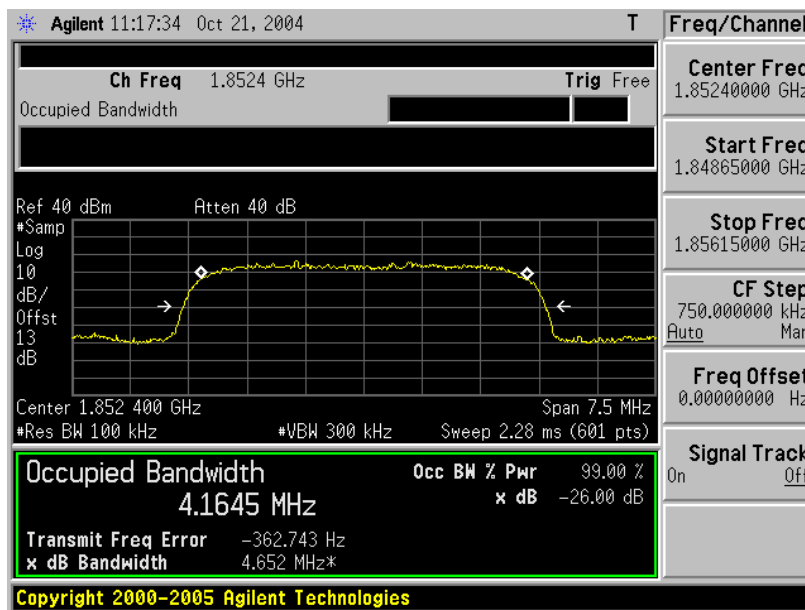



Channel 9400

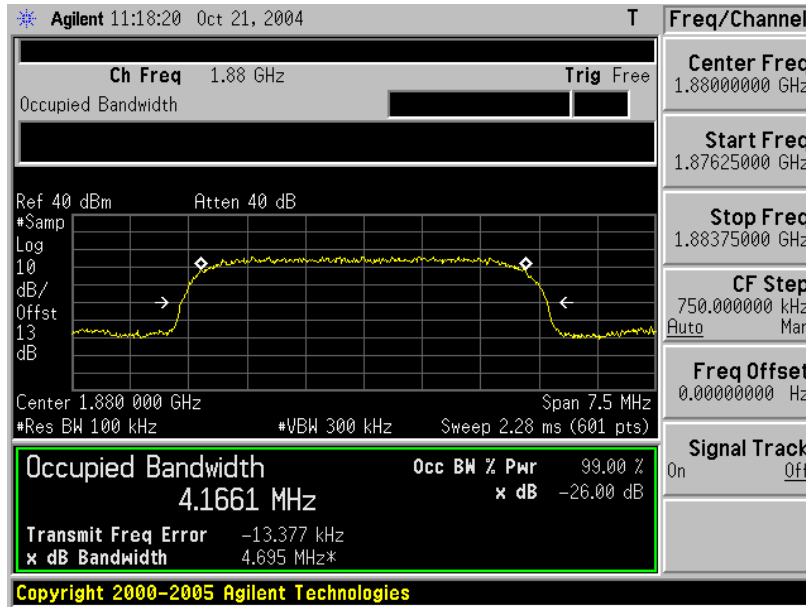

Channel 9538

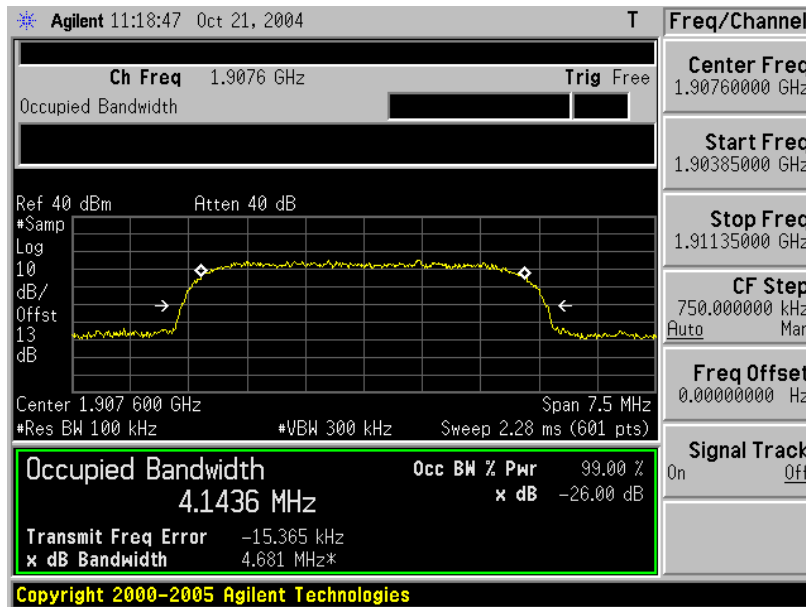

Model Number	PJ03120		
Test Item	Occupied Bandwidth		
Test Mode	Mode 4: WCDMA Band V Link		
Date of Test	10/07/2011	Test Site	TE02
Channel No.	Frequency (MHz)	99% Bandwidth (kHz)	Note
4132	826.4	4.1722	RBW:100KHz , VBW:300KHz
4182	836.4	4.1615	RBW:100KHz , VBW:300KHz
4233	846.4	4.1496	RBW:100KHz , VBW:300KHz

## Channel 4132

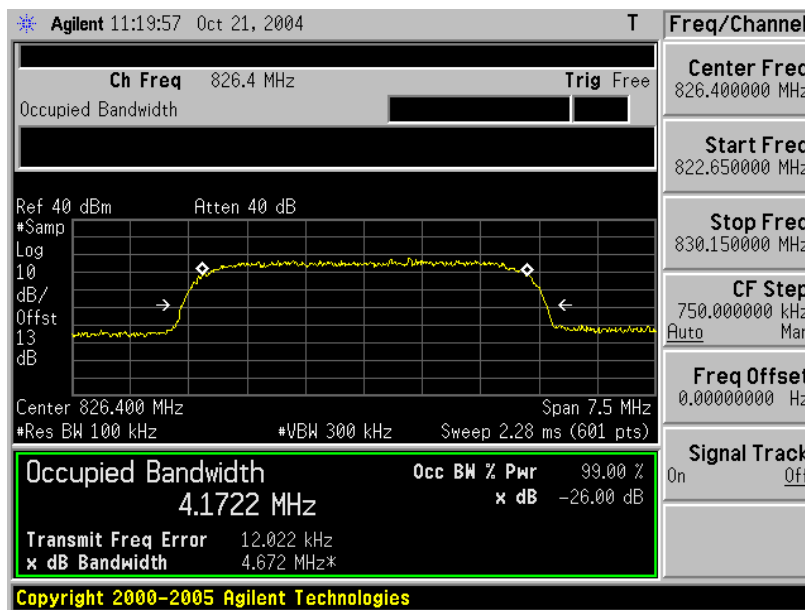

Channel 4182

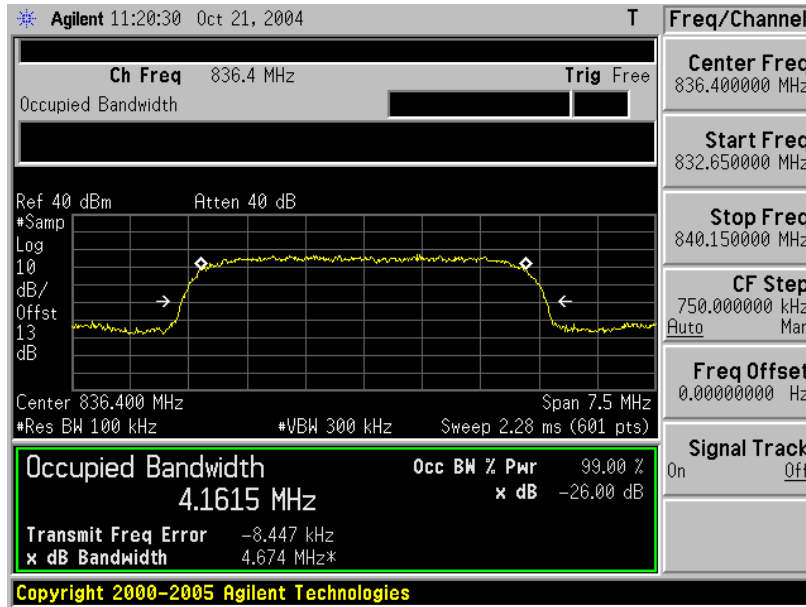

Channel 4233

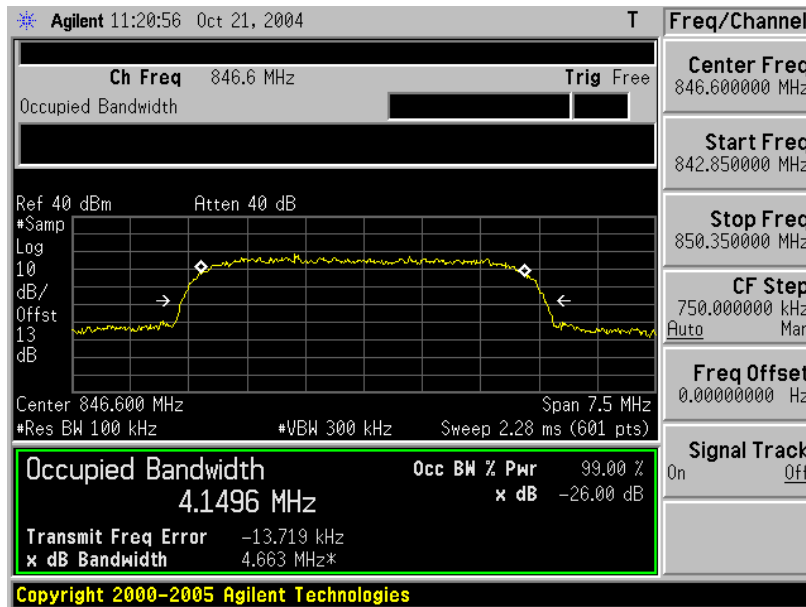

Model Number	PJ03120		
Test Item	Occupied Bandwidth		
Test Mode	Mode 5: EGPRS 850 Link		
Date of Test	10/07/2011	Test Site	TE02
Channel No.	Frequency (MHz)	99% Bandwidth (kHz)	Note
128	824.2	243.3951	RBW:10KHz , VBW:30KHz
190	836.4	239.2211	RBW:10KHz , VBW:30KHz
251	848.8	240.7727	RBW:10KHz , VBW:30KHz

## Channel 128

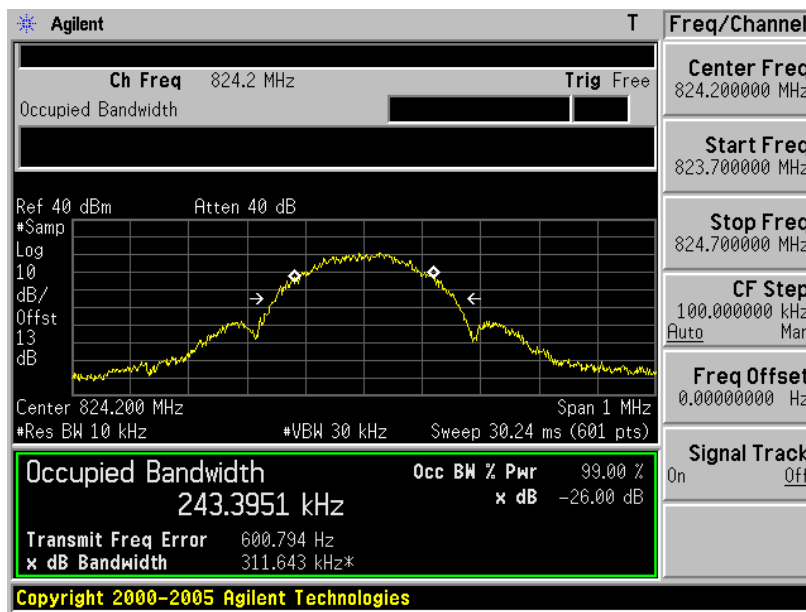

Channel 190

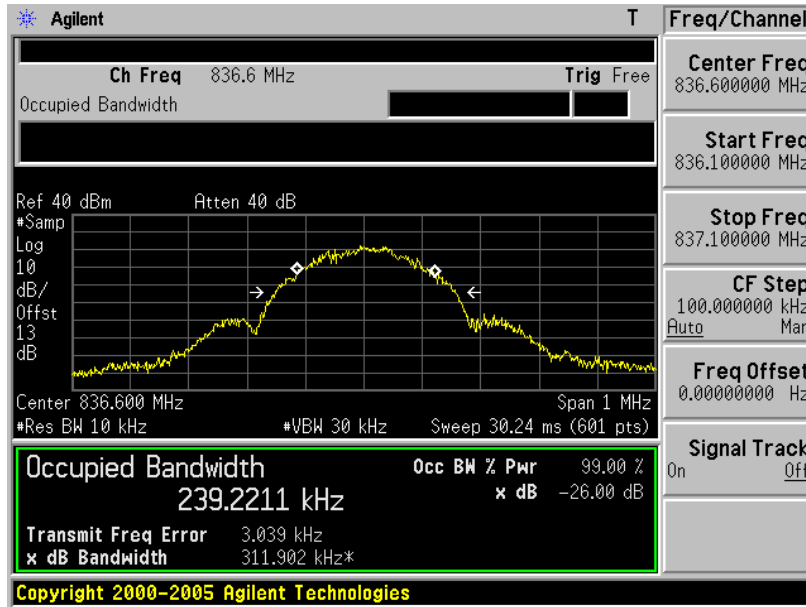

Channel 251

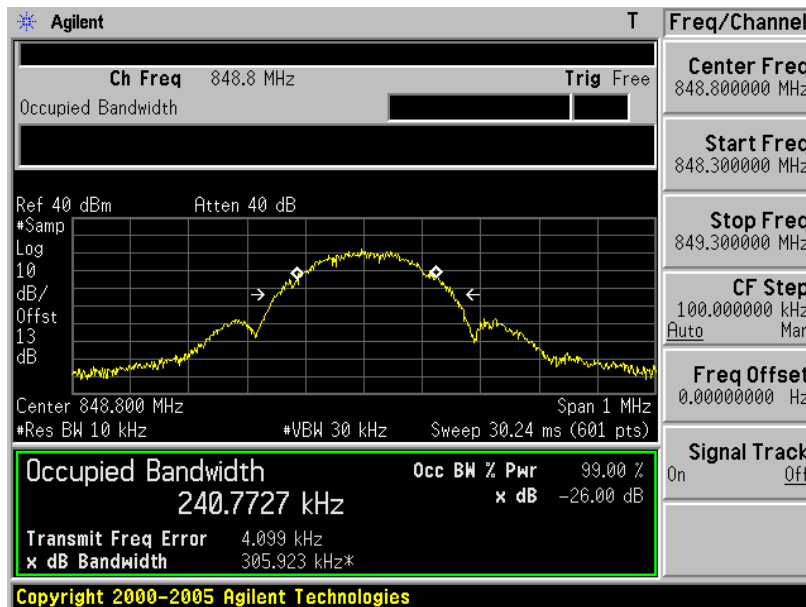

Model Number	PJ03120		
Test Item	Occupied Bandwidth		
Test Mode	Mode 6: EGPRS 1900 Link		
Date of Test	10/07/2011	Test Site	TE02
Channel No.	Frequency (MHz)	99% Bandwidth (kHz)	Note
512	1850.20	238.6294	RBW:10KHz , VBW:30KHz
661	1880.00	242.2897	RBW:10KHz , VBW:30KHz
810	1909.80	238.6110	RBW:10KHz , VBW:30KHz

## Channel 512

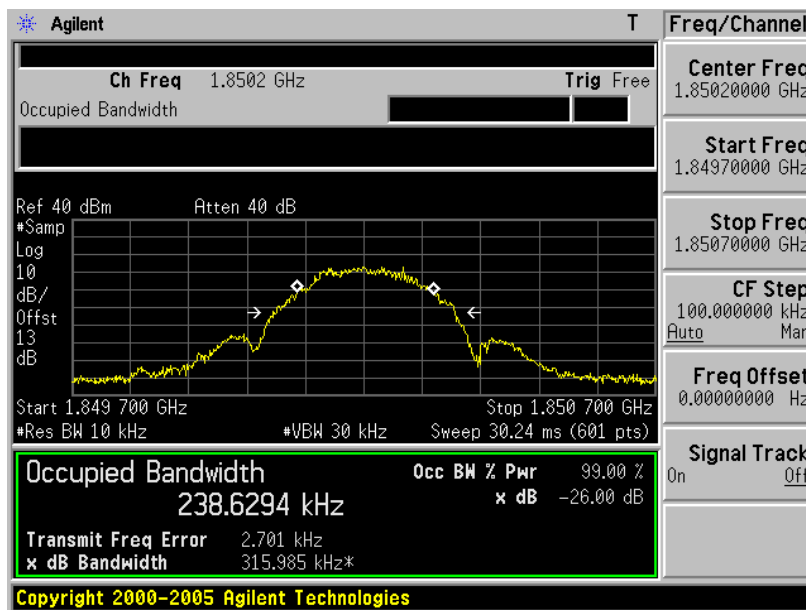

Channel 661

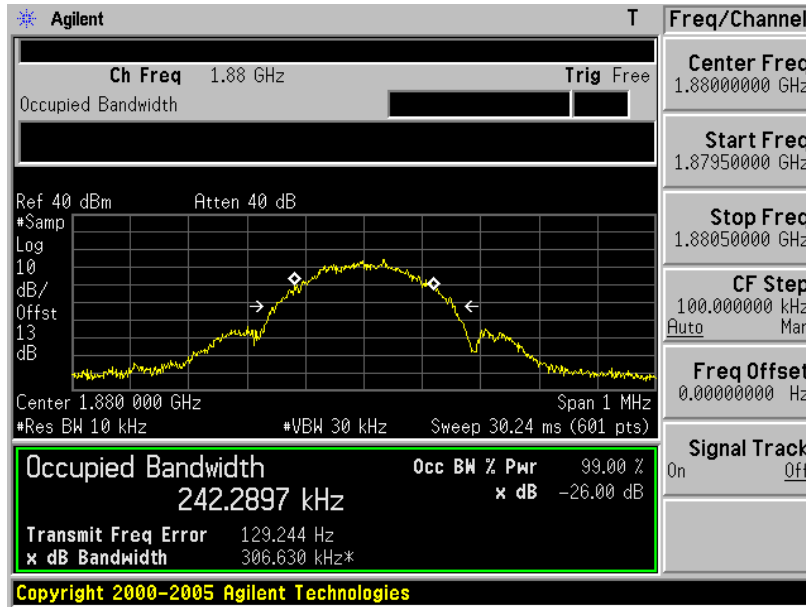

Channel 810

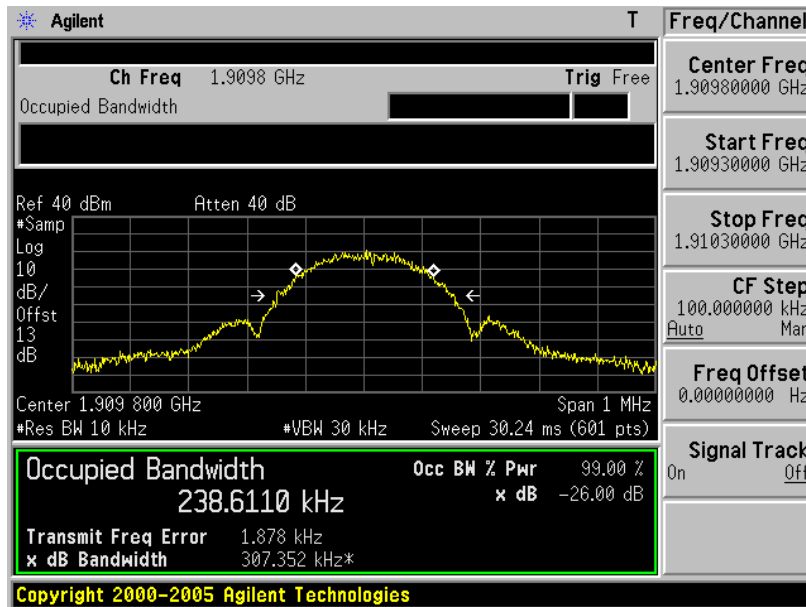

**Band Edge**

Model Number	PJ03120				
Test Item	Band Edge				
Test Mode	Mode 1: GSM 850 Link				
Date of Test	09/09/2011		Test Site	TE02	
Band	Channel	Frequency (MHz)	Bandwidth (dBm)	Limit (dBm)	Result
Lower	128	824.0000	-16.85	-13	Pass
Higher	251	849.0000	-14.09	-13	Pass

Lower Band

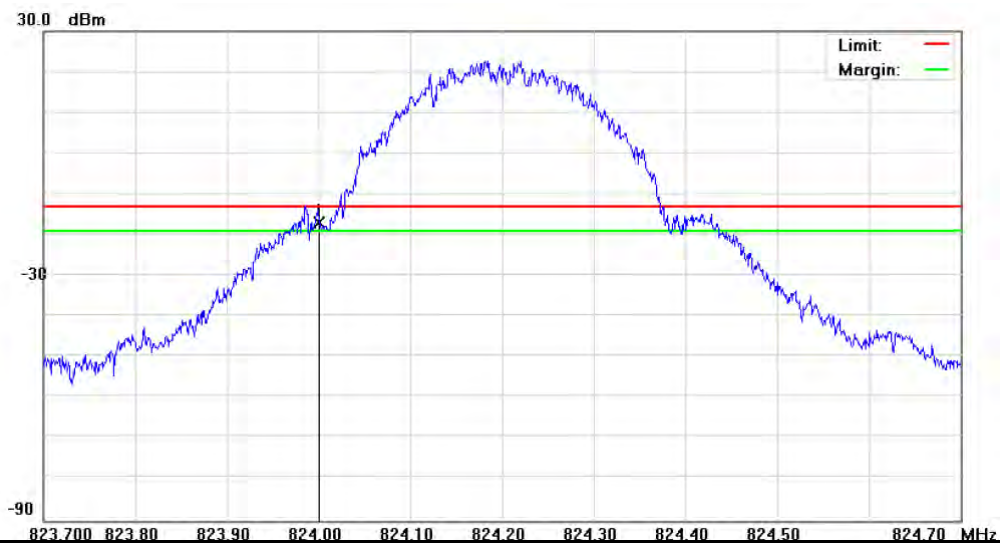

Higher Band

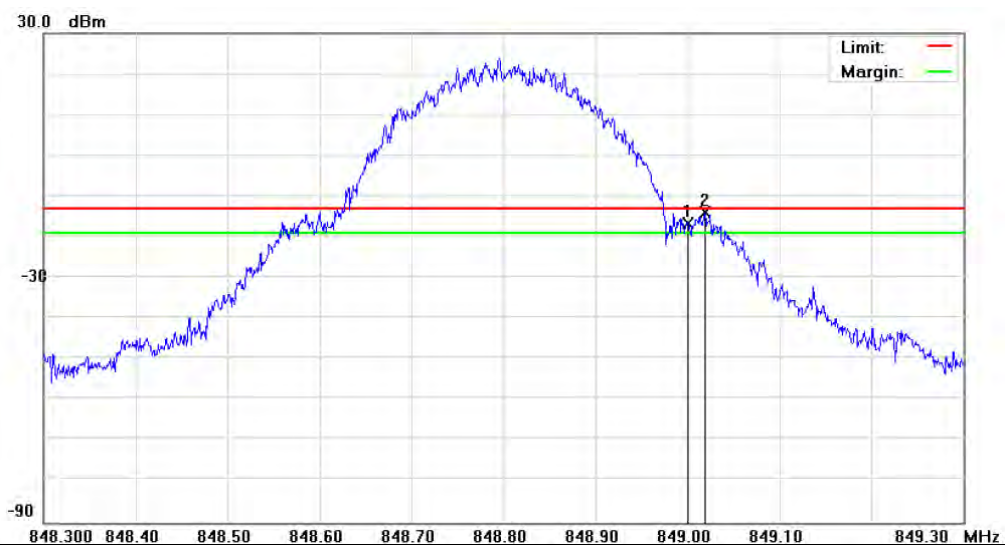



Model Number	PJ03120				
Test Item	Band Edge				
Test Mode	Mode 2: GSM 1900 Link				
Date of Test	09/09/2011		Test Site	TE02	
Band	Channel	Frequency (MHz)	Bandwidth (dBm)	Limit (dBm)	Result
Lower	512	1850.000	-15.00	-13	Pass
Higher	810	1910.000	-15.70	-13	Pass

Lower Band



Higher Band

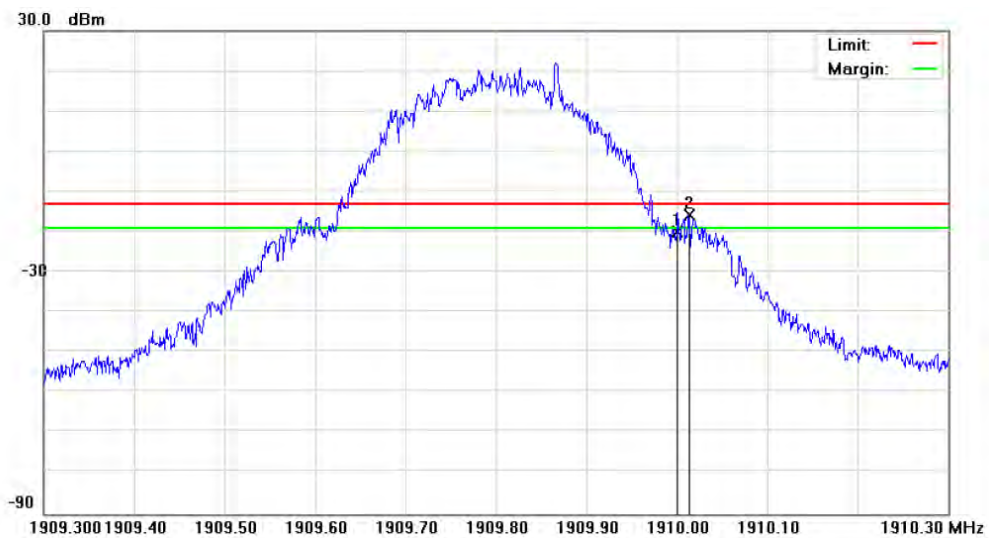

Model Number	PJ03120				
Test Item	Band Edge				
Test Mode	Mode 3: WCDMA Band II Link				
Date of Test	09/09/2011		Test Site	TE02	
Band	Channel	Frequency (MHz)	Bandwidth (dBm)	Limit (dBm)	Result
Lower	9262	1850.000	-24.61	-13	Pass
Higher	9538	1910.000	-23.42	-13	Pass

Lower Band

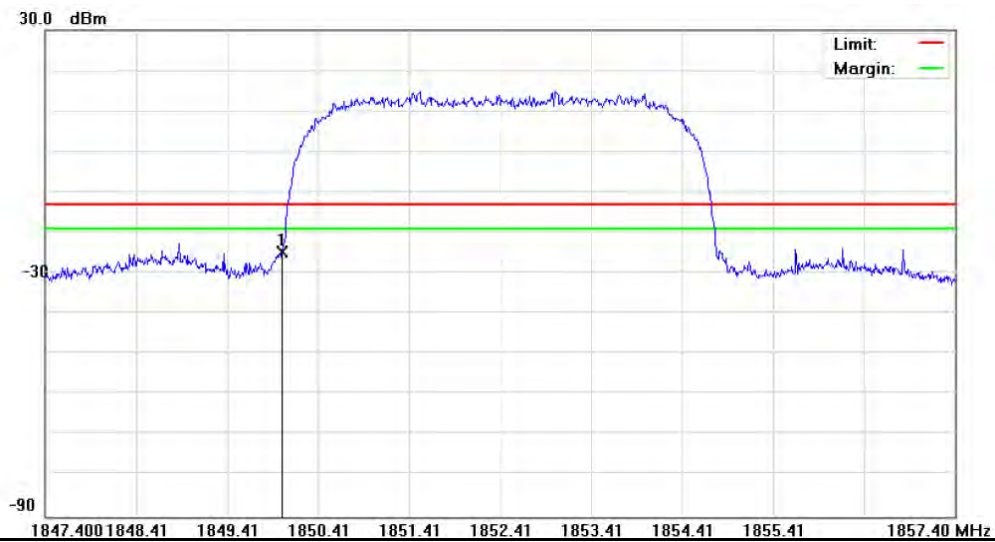

Higher Band

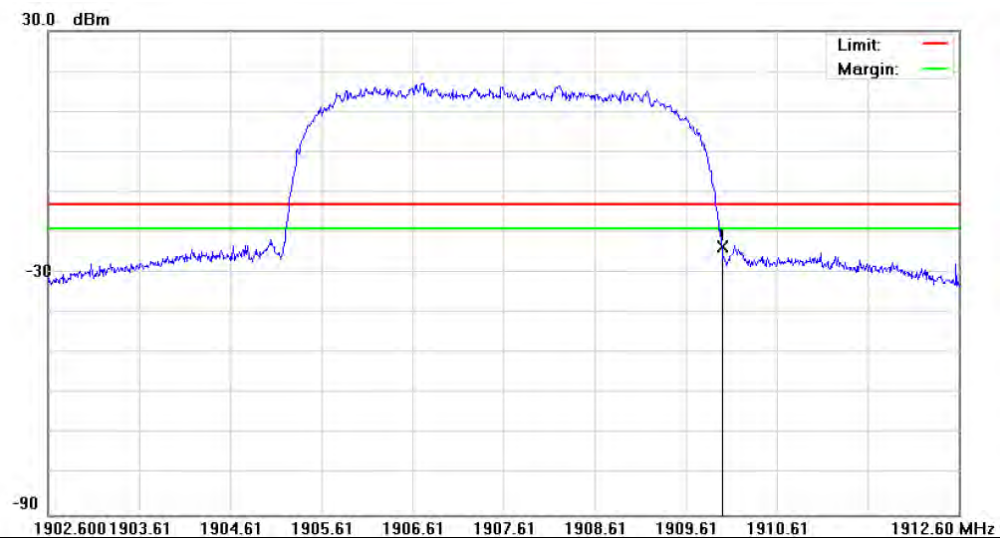

Model Number	PJ03120				
Test Item	Band Edge				
Test Mode	Mode 4: WCDMA Band V Link				
Date of Test	09/09/2011		Test Site	TE02	
Band	Channel	Frequency (MHz)	Bandwidth (dBm)	Limit (dBm)	Result
Lower	4132	824.0000	-24.01	-13	Pass
Higher	4233	849.0000	-23.85	-13	Pass

Lower Band

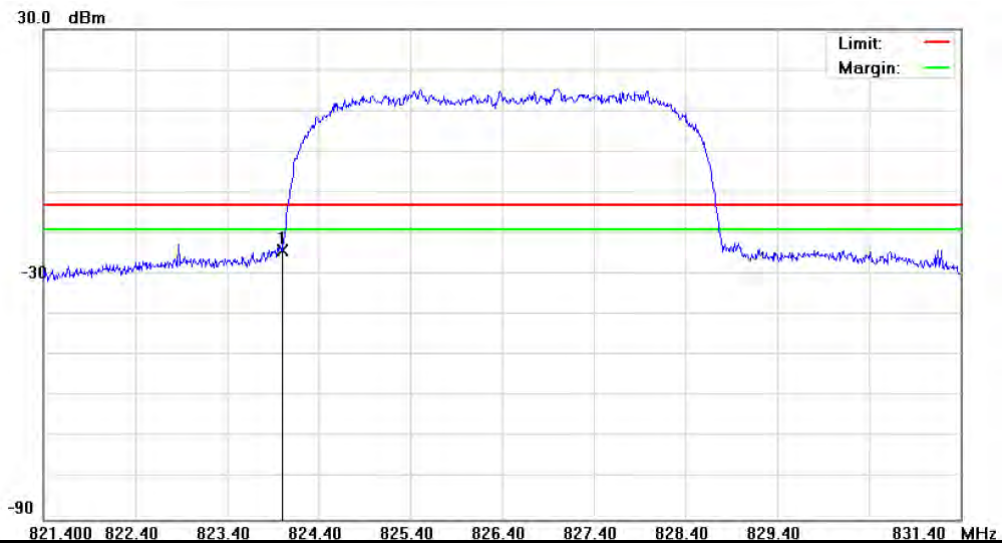

Higher Band

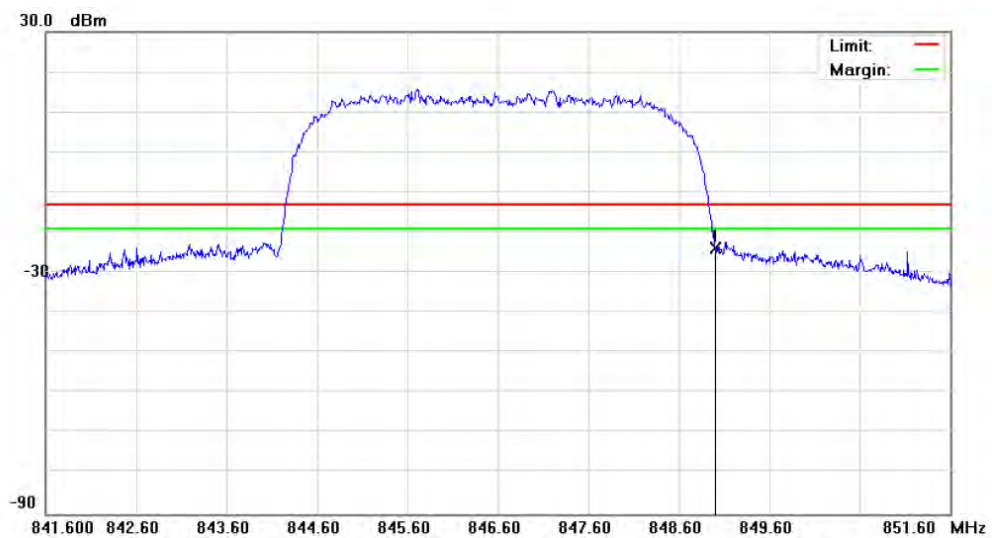

## 5 Conducted Emission Test

### 5.1. Limit

The power of any emission outside of the authorized operating frequency ranges must be attenuated below the transmitting power (P) by a factor of at least  $43 + 10\log(P)$  dB.

### 5.2. Test Instruments

Describe	Manufacturer	Model No.	Serial No.	Cal. Date	Remark
Spectrum Analyzer	Agilent	E4445A	MY46181986	05/16/2011	(2)
Universal Radio Communication Tester	ROHDE & SCHWARZ	CMU200	109369	08/10/2010	(2)
Attenuator	RADIALL	R41572000	0603033073	N.C.R.	-----
Power divider	Agilent	87302C	3239A00760	N.C.R.	-----
Test Site	ATL	TE02	TE02	N.C.R.	-----

Remark: <sup>(1)</sup> Calibration period 1 year. <sup>(2)</sup> Calibration period 2 years.

NOTE: N.C.R. = No Calibration Request.

### 5.3. Setup

Below 2.8GHz

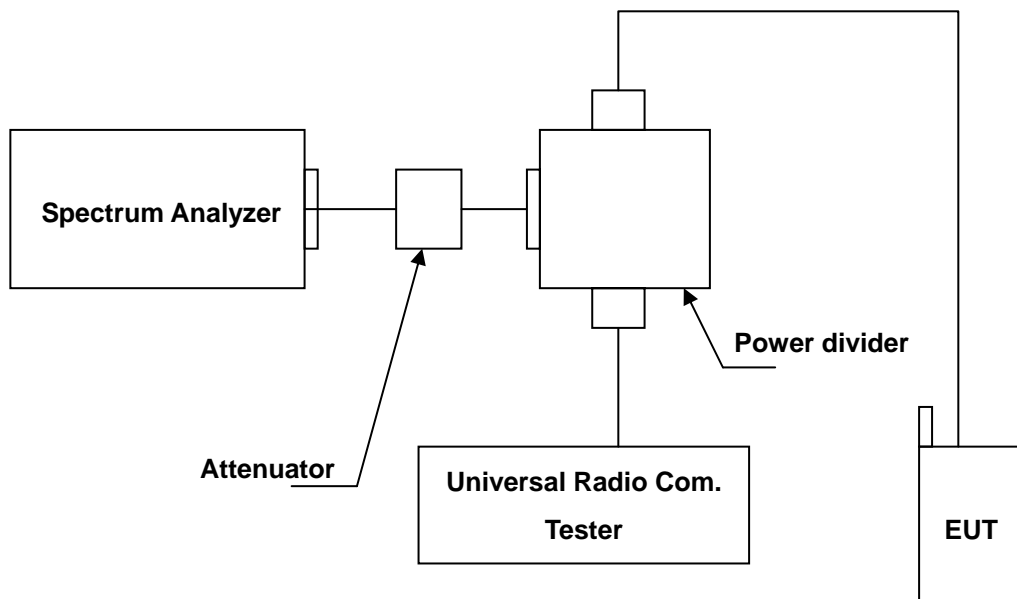

**Above 2.8GHz**

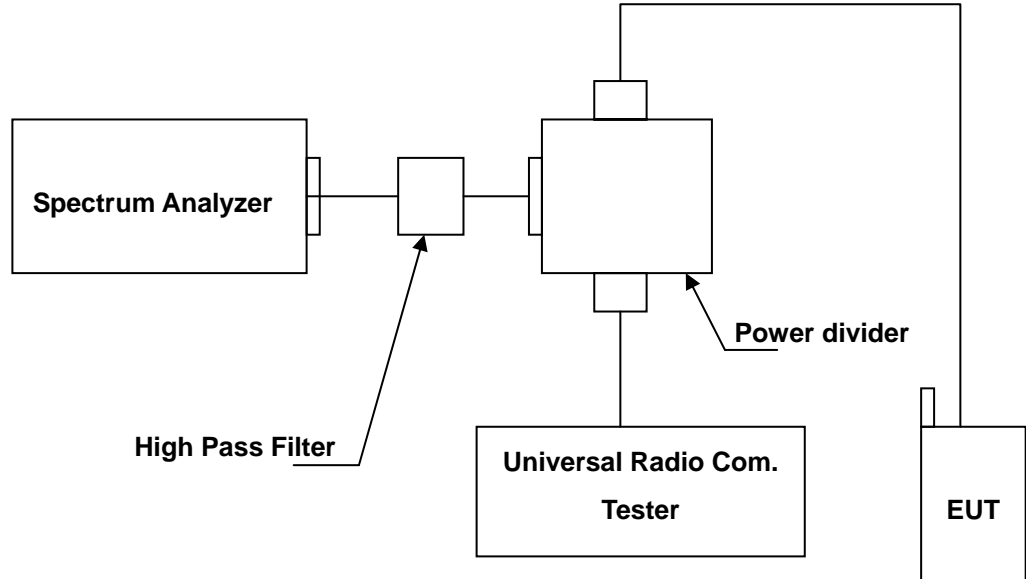

**5.4. Test Procedure**

1. The EUT was connected to Spectrum Analyzer and Base Station via power divider.
2. The middle channel for the highest RF power within the transmitting frequency was measured.
3. The conducted spurious emission for the whole frequency range was taken.
4. Test setting at GSM 850 RB>100 kHz, VB>100 kHz; PCS 1900 RB>1MHz, VB>1MHz.

**5.5. Uncertainty**

The measurement uncertainty is evaluated as  $\pm 2.24$  dB.

**5.6. Test Result**

Model Number	PJ03120		
Test Item	Conducted Emission		
Mode	Mode 1: GSM 850 Link Mode 2: GSM 1900 Link Mode 3: WCDMA Band II Link Mode 4: WCDMA Band V Link		
Date of Test	09/09/2011	Test Site	TE02

File: PJ03120(CH128)

Data :#1

Date: 2011/9/9

Time: 下午 02:40:33

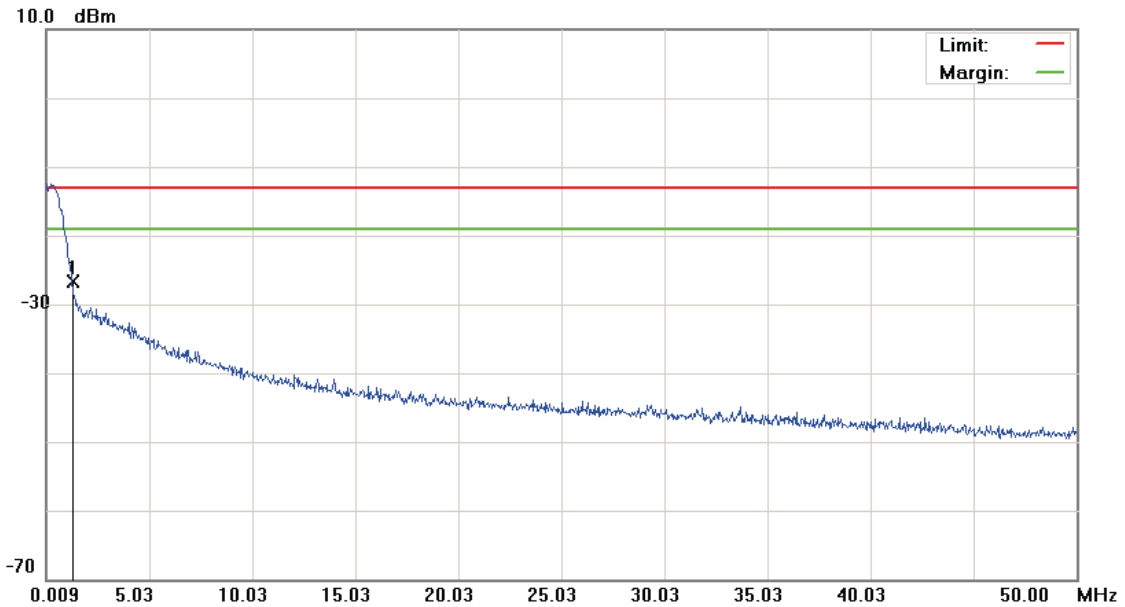

Site: : RF Conducted	Polarization: <i>Conducted po</i>	Temperature: 24.2 °C
Limit: FCC Part 22 conducted(9k-12.75G)	Power: AC 120V/60Hz	Humidity: 54 %
EUT: Smartphone	Distance:	RBW: 1000 KHz VBW: 1000 KHz
M/N: PJ03120		
Mode: GSM 850		
Note: CH128		

No.	Mk.	Freq.	Reading Level	Correct Factor	Measurement	Limit	Over	Antenna Height	Table Degree	
		MHz	dBm	dB	dBm	dBm	dB	cm	degree	Comment
1	*	1.2838	-58.03	31.43	-26.60	-13.00	-13.60			peak

\*:Maximum data    x:Over limit    !:over margin

File: PJ03120(CH128)

Data :#2

Date: 2011/9/9

Time: 下午 02:40:57

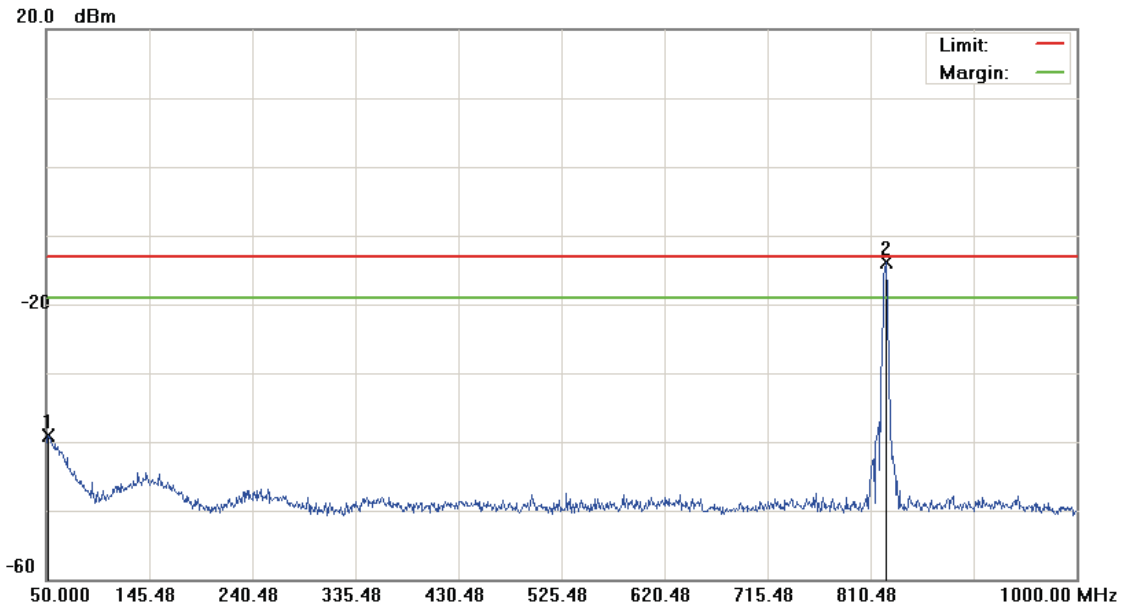

Site: : RF Conducted

 Polarization: *Conducted po*

Temperature: 24.2 °C

Limit: FCC Part 22 conducted(9k-12.75G)

Power: AC 120V/60Hz

Humidity: 54 %

EUT: Smartphone

Distance:

RBW: 1000 KHz VBW: 1000 KHz

M/N: PJ03120

Mode: GSM 850

Note: CH128

No.	Mk.	Freq. MHz	Reading Level dBm	Correct Factor dB	Measure- ment dBm	Limit dBm	Over dB	Detector	Antenna Height cm	Table Degree degree	Comment
1		51.9000	-53.49	14.36	-39.13	-13.00	-26.13	peak			
2	*	824.2500	-17.82	3.84	-13.98	-13.00	-0.98	peak			Tx

\*:Maximum data    x:Over limit    !:over margin

File: PJ03120(CH128)

Data :#3

Date: 2011/9/9

Time: 下午 02:44:33

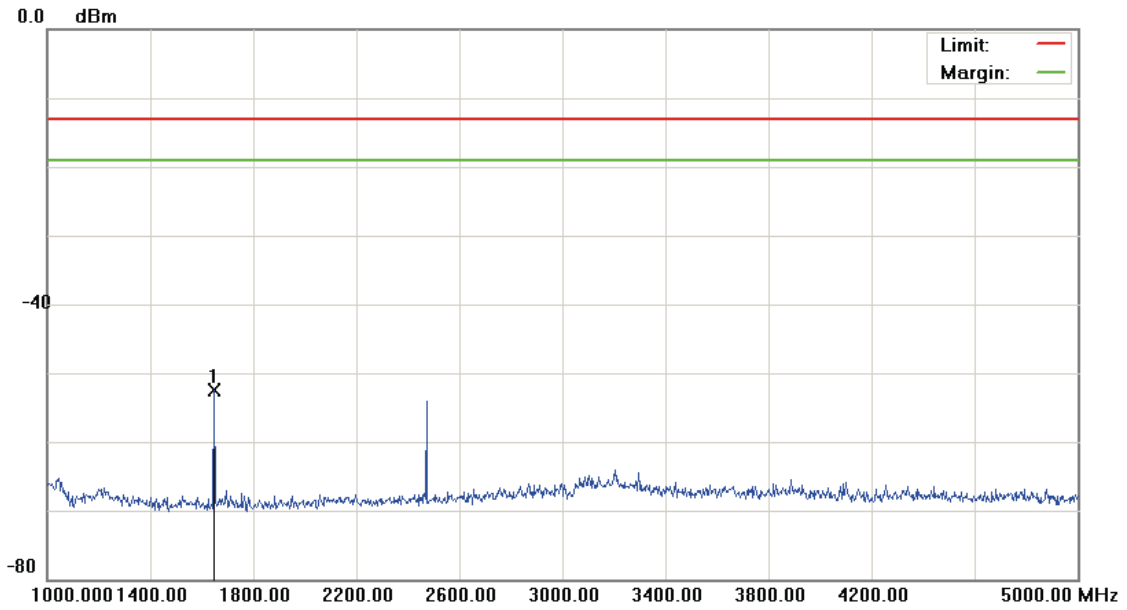

Site: : RF Conducted	Polarization: <i>Conducted po</i>	Temperature: 24.2 °C
Limit: FCC Part 22 conducted(9k-12.75G)	Power: AC 120V/60Hz	Humidity: 54 %
EUT: Smartphone	Distance:	RBW: 1000 KHz VBW: 1000 KHz
M/N: PJ03120		
Mode: GSM 850		
Note: CH128		

No.	Mk.	Freq. MHz	Reading Level dBm	Correct Factor dB	Measure- ment dBm	Limit dBm	Over dB	Detector	Antenna Height cm	Table Degree degree	Comment
1	*	1648.000	-56.98	4.45	-52.53	-13.00	-39.53	peak			

\*:Maximum data    x:Over limit    !:over margin



File: PJ03120(CH128)

Data :#4

Date: 2011/9/9

Time: 下午 02:44:56

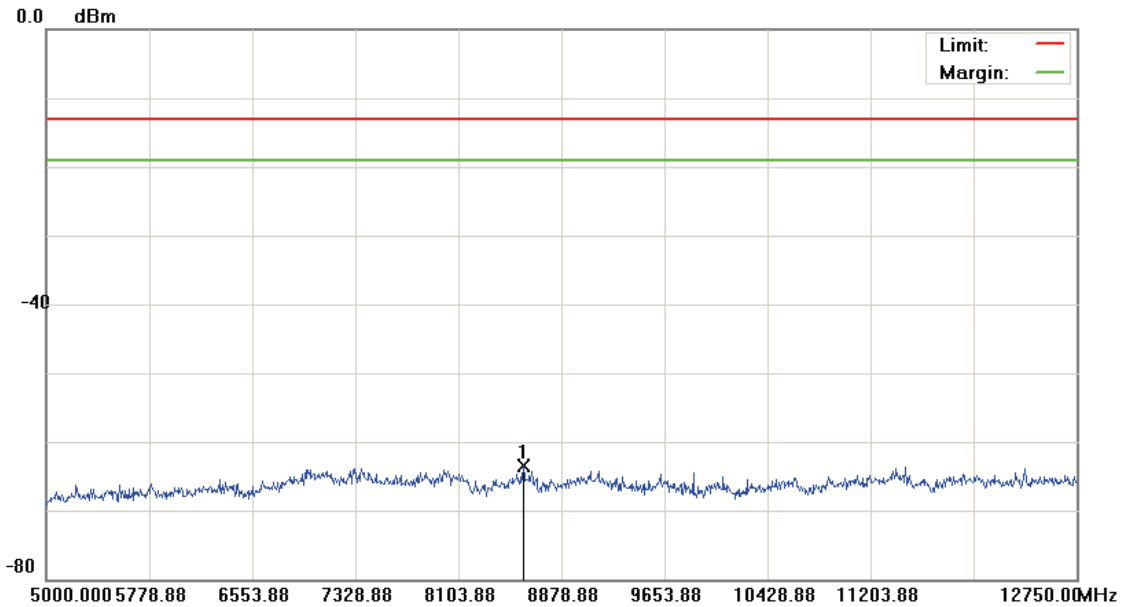

Site: : RF Conducted	Polarization: <i>Conducted po</i>	Temperature: 24.2 °C
Limit: FCC Part 22 conducted(9k-12.75G)	Power: AC 120V/60Hz	Humidity: 54 %
EUT: Smartphone	Distance:	RBW: 1000 KHz VBW: 1000 KHz
M/N: PJ03120		
Mode: GSM 850		
Note: CH128		

No.	Mk.	Freq.	Reading Level	Correct Factor	Measurement	Limit	Over	Antenna Height	Table Degree	Detector	Comment
		MHz	dBm	dB	dBm	dBm	dB	cm	degree		
1	*	8588.250	-69.23	5.72	-63.51	-13.00	-50.51			peak	

\*:Maximum data    x:Over limit    !:over margin

File: PJ03120(CH190)

Data: #1

Date: 2011/9/9

Time: 下午 02:47:26

10.0 dBm

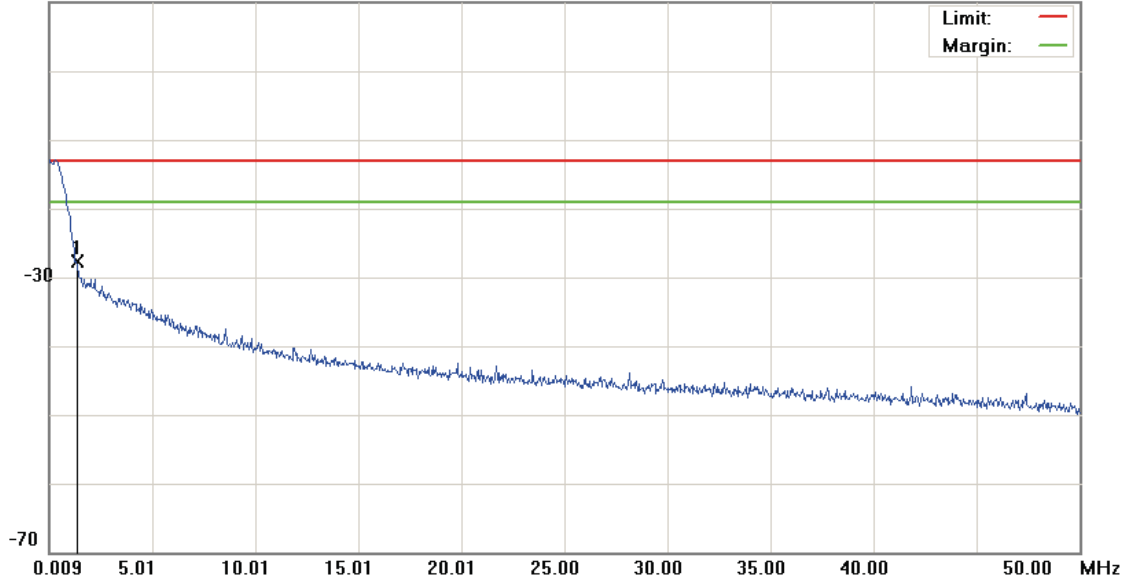

Site: : RF Conducted	Polarization: <i>Conducted po</i>	Temperature: 24.2 °C
Limit: FCC Part 22 conducted(9k-12.75G)	Power: AC 120V/60Hz	Humidity: 54 %
EUT: Smartphone	Distance:	RBW: 1000 KHz VBW: 1000 KHz
M/N: PJ03120		
Mode: GSM 850		
Note: CH190		

No.	Mk.	Freq.	Reading Level	Correct Factor	Measurement	Limit	Over	Antenna Height	Table Degree	
		MHz	dBm	dB	dBm	dBm	dB	cm	degree	Comment
1	*	1.3338	-58.97	31.36	-27.61	-13.00	-14.61			peak

\*:Maximum data    x:Over limit    !:over margin

File: PJ03120(CH190)

Data :#2

Date: 2011/9/9

Time: 下午 02:47:51

20.0 dBm

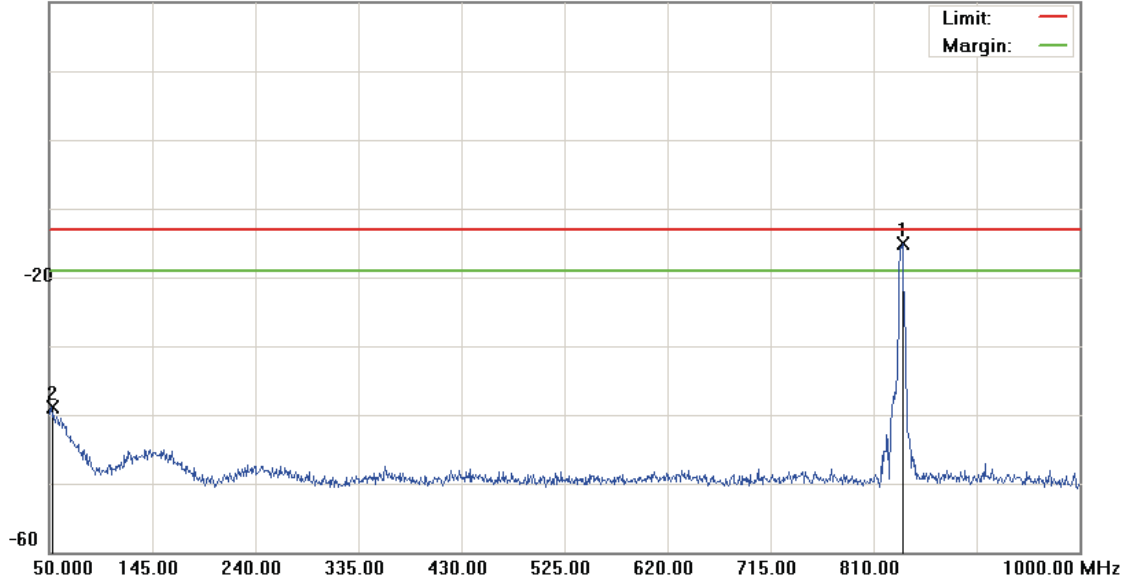

Site: : RF Conducted	Polarization: <i>Conducted po</i>	Temperature: 24.2 °C
Limit: FCC Part 22 conducted(9k-12.75G)	Power: AC 120V/60Hz	Humidity: 54 %
EUT: Smartphone	Distance:	RBW: 1000 KHz VBW: 1000 KHz
M/N: PJ03120		
Mode: GSM 850		
Note: CH190		

No.	Mk.	Freq. MHz	Reading Level dBm	Correct Factor dB	Measure- ment dBm	Limit dBm	Over dB	Detector	Antenna Height cm	Table Degree degree	Comment
1	*	836.6000	-18.98	3.96	-15.02	-13.00	-2.02	peak			TX
2		52.3750	-53.19	14.27	-38.92	-13.00	-25.92	peak			

\*:Maximum data    x:Over limit    !:over margin

File: PJ03120(CH190)

Data :#3

Date: 2011/9/9

Time: 下午 02:52:55

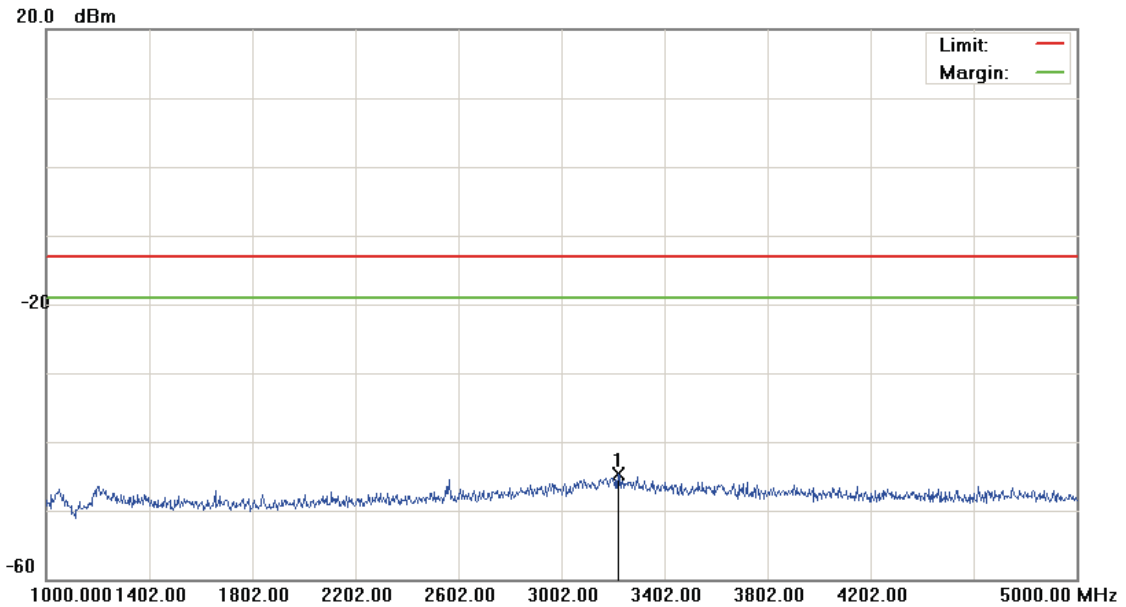

Site: : RF Conducted	Polarization: <i>Conducted po</i>	Temperature: 24.2 °C
Limit: FCC Part 22 conducted(9k-12.75G)	Power: AC 120V/60Hz	Humidity: 54 %
EUT: Smartphone	Distance:	RBW: 1000 KHz VBW: 1000 KHz
M/N: PJ03120		
Mode: GSM 850		
Note: CH190		

No.	Mk.	Freq. MHz	Reading Level dBm	Correct Factor dB	Measure- ment dBm	Limit dBm	Over dB	Detector	Antenna Height cm	Table Degree degree	Comment
1	*	3220.000	-49.33	4.68	-44.65	-13.00	-31.65	peak			

\*:Maximum data    x:Over limit    !:over margin

File: PJ03120(CH190)

Data :#4

Date: 2011/9/9

Time: 下午 02:53:18

20.0 dBm

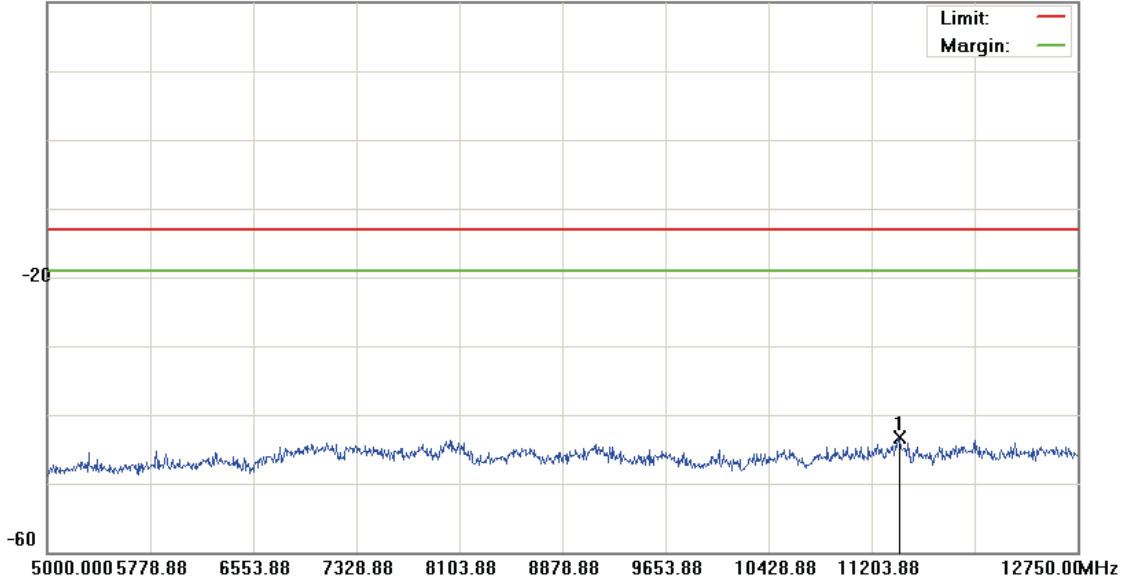

Site: : RF Conducted	Polarization: <i>Conducted po</i>	Temperature: 24.2 °C
Limit: FCC Part 22 conducted(9k-12.75G)	Power: AC 120V/60Hz	Humidity: 54 %
EUT: Smartphone	Distance:	RBW: 1000 KHz VBW: 1000 KHz
M/N: PJ03120		
Mode: GSM 850		
Note: CH190		

No.	Mk.	Freq. MHz	Reading Level dBm	Correct Factor dB	Measure- ment dBm	Limit dBm	Over dB	Detector	Antenna Height cm	Table Degree degree	Comment
1	*	11405.375	-48.90	5.56	-43.34	-13.00	-30.34	peak			

\*:Maximum data    x:Over limit    !:over margin

File: PJ03120(CH251)

Data: #1

Date: 2011/9/9

Time: 下午 02:56:12

10.0 dBm

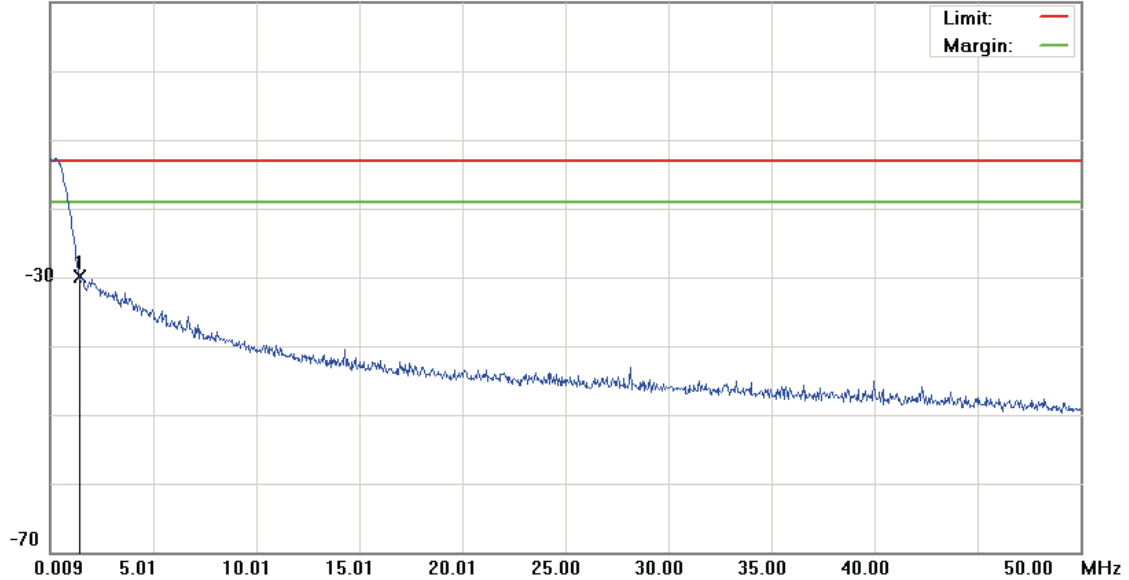

Site: : RF Conducted	Polarization: <i>Conducted po</i>	Temperature: 24.2 °C
Limit: FCC Part 22 conducted(9k-12.75G)	Power: AC 110V/60Hz	Humidity: 54 %
EUT: Smartphone	Distance:	RBW: 1000 KHz VBW: 1000 KHz
M/N: PH85110		
Mode: GSM 850		
Note: CH251		

No.	Mk.	Freq.	Reading Level	Correct Factor	Measurement	Limit	Over	Antenna Height	Table Degree	Detector	Comment
		MHz	dBm	dB	dBm	dBm	dB	cm	degree		
1	*	1.4587	-61.34	31.40	-29.94	-13.00	-16.94			peak	

\*:Maximum data    x:Over limit    !:over margin

File: PJ03120(CH251)

Data :#2

Date: 2011/9/9

Time: 下午 02:56:36

20.0 dBm

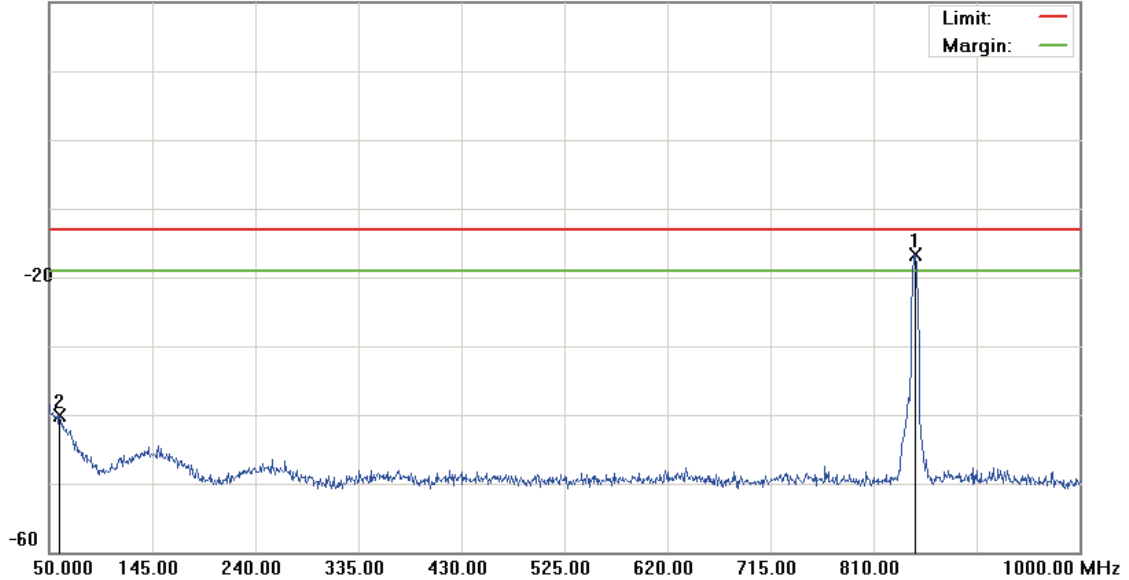

Site: : RF Conducted	Polarization: <i>Conducted po</i>	Temperature: 24.2 °C
Limit: FCC Part 22 conducted(9k-12.75G)	Power: AC 110V/60Hz	Humidity: 54 %
EUT: Smartphone	Distance:	RBW: 1000 KHz VBW: 1000 KHz
M/N: PH85110		
Mode: GSM 850		
Note: CH251		

No.	Mk.	Freq. MHz	Reading Level dBm	Correct Factor dB	Measure- ment dBm	Limit dBm	Over dB	Detector	Antenna Height cm	Table Degree degree	Comment
1	*	847.5250	-20.67	3.98	-16.69	-13.00	-3.69	peak			TX
2		59.5000	-53.12	12.97	-40.15	-13.00	-27.15	peak			

\*:Maximum data    x:Over limit    !:over margin

File: PJ03120(CH251)

Data: #3

Date: 2011/9/9

Time: 下午 02:58:00

20.0 dBm

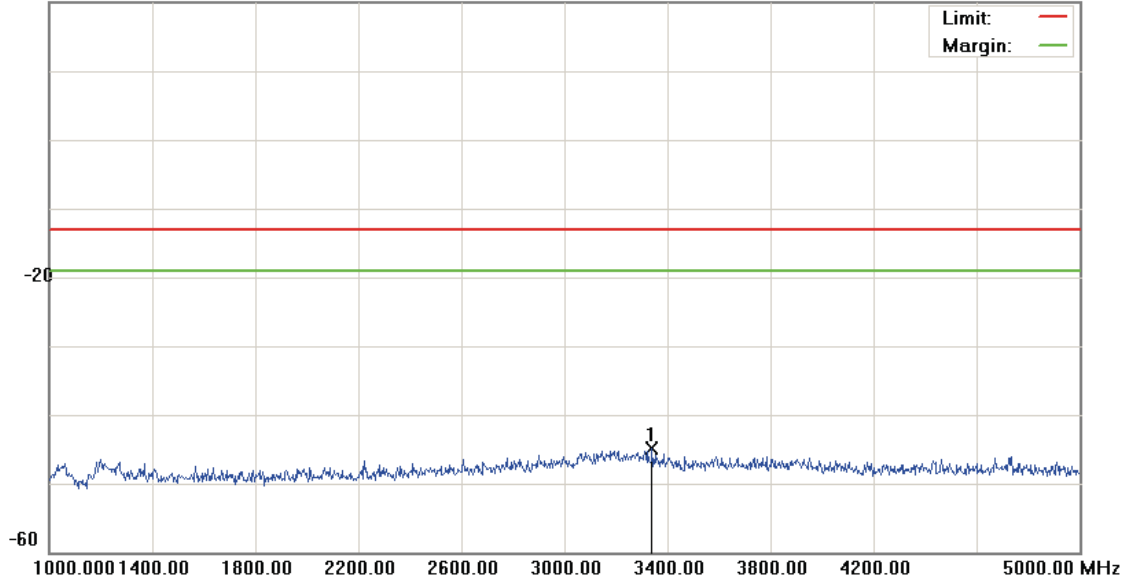

Site: : RF Conducted	Polarization: <i>Conducted po</i>	Temperature: 24.2 °C
Limit: FCC Part 22 conducted(9k-12.75G)	Power: AC 120V/60Hz	Humidity: 54 %
EUT: Smartphone	Distance:	RBW: 1000 KHz VBW: 1000 KHz
M/N: PH85110		
Mode: GSM 850		
Note: CH251		

No.	Mk.	Freq.	Reading Level	Correct Factor	Measurement	Limit	Over	Antenna Height	Table Degree	Detector	Comment
		MHz	dBm	dB	dBm	dBm	dB	cm	degree		
1	*	3340.000	-49.34	4.50	-44.84	-13.00	-31.84			peak	

\*:Maximum data    x:Over limit    !:over margin



File: PJ03120(CH251)

Data :#4

Date: 2011/9/9

Time: 下午 02:58:23

20.0 dBm

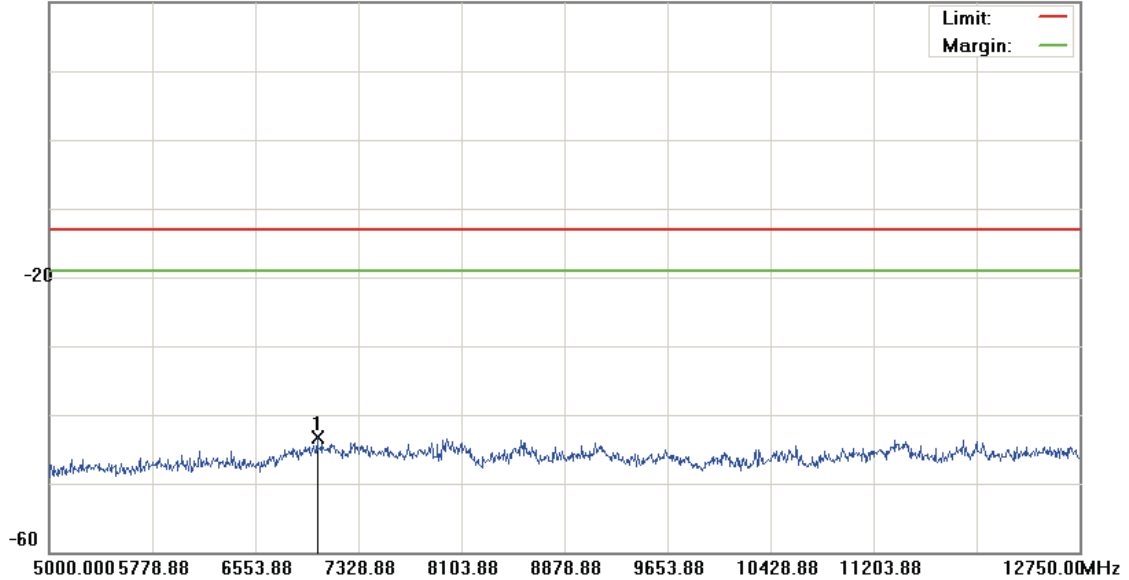

Site: : RF Conducted	Polarization: <i>Conducted po</i>	Temperature: 24.2 °C
Limit: FCC Part 22 conducted(9k-12.75G)	Power: AC 120V/60Hz	Humidity: 54 %
EUT: Smartphone	Distance:	RBW: 1000 KHz VBW: 1000 KHz
M/N: PH85110		
Mode: GSM 850		
Note: CH251		

No.	Mk.	Freq. MHz	Reading Level dBm	Correct Factor dB	Measure- ment dBm	Limit dBm	Over dB	Detector	Antenna Height cm	Table Degree degree	Comment
1	*	7015.000	-48.26	4.89	-43.37	-13.00	-30.37	peak			

\*:Maximum data    x:Over limit    !:over margin

File: PJ03120(CH512)

Data :#1

Date: 2011/9/9

Time: 下午 03:05:37

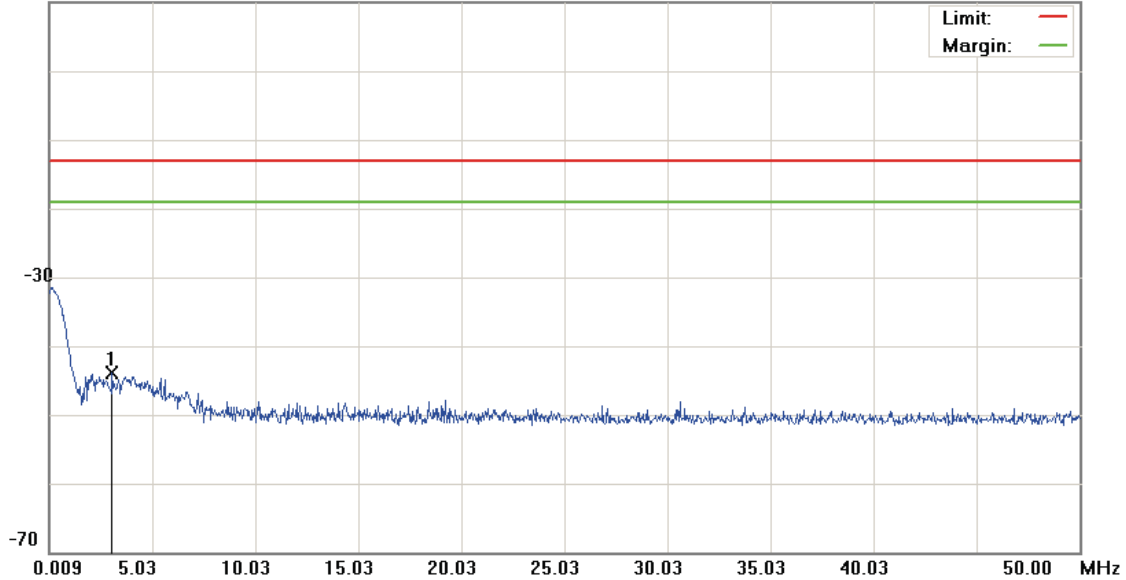
**10.0 dBm**

Site: : RF Conducted	Polarization: <i>Conducted po</i>	Temperature: 24.2 °C
Limit: FCC Part 24 conducted(9k-12.75G)	Power: AC 120V/60Hz	Humidity: 54 %
EUT: Smartphone	Distance:	RBW: 1000 KHz VBW: 1000 KHz
M/N: PJ03120		
Mode: PCS 1900		
Note: CH512		

No.	Mk.	Freq.	Reading Level	Correct Factor	Measurement	Limit	Over	Antenna Height	Table Degree	Detector	Comment
		MHz	dBm	dB	dBm	dBm	dB	cm	degree		
1	*	3.0584	-56.96	13.00	-43.96	-13.00	-30.96			peak	

\*:Maximum data    x:Over limit    !:over margin

File: PJ03120(CH512)

Data :#2

Date: 2011/9/9

Time: 下午 03:06:01

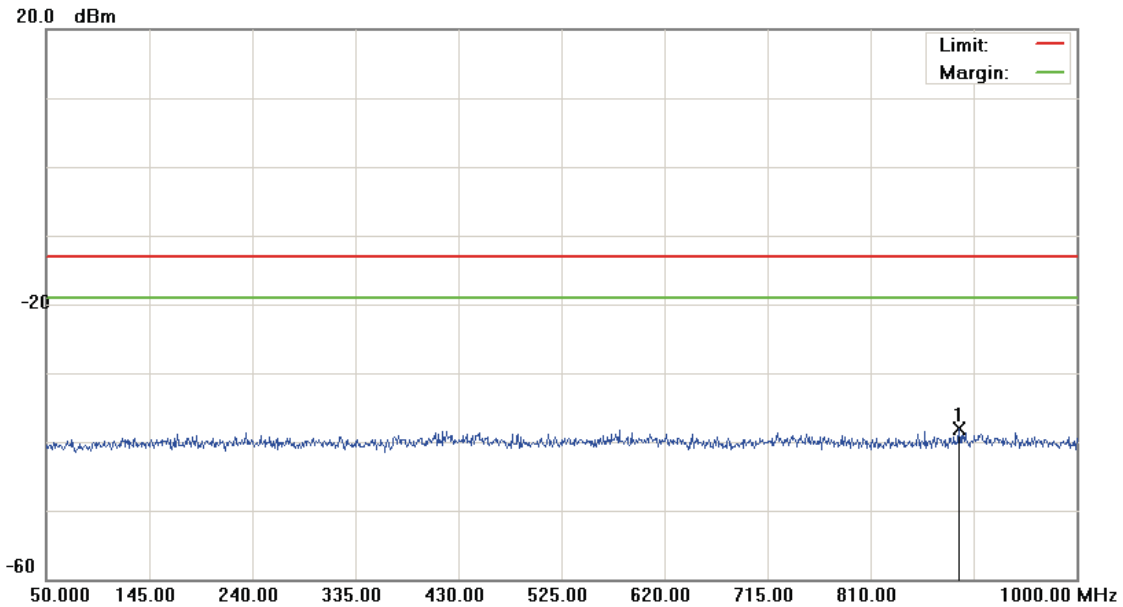

Site: : RF Conducted	Polarization: <i>Conducted po</i>	Temperature: 24.2 °C
Limit: FCC Part 24 conducted(9k-12.75G)	Power: AC 120V/60Hz	Humidity: 54 %
EUT: Smartphone	Distance:	RBW: 1000 KHz VBW: 1000 KHz
M/N: PJ03120		
Mode: PCS 1900		
Note: CH512		

No.	Mk.	Freq.	Reading Level	Correct Factor	Measurement	Limit	Over	Antenna Height	Table Degree
		MHz	dBm	dB	dBm	dBm	dB	cm	degree
1	*	891.7000	-51.28	13.23	-38.05	-13.00	-25.05	peak	

\*:Maximum data x:Over limit !:over margin

File: PJ03120(CH512)

Data :#3

Date: 2011/9/9

Time: 下午 03:11:50

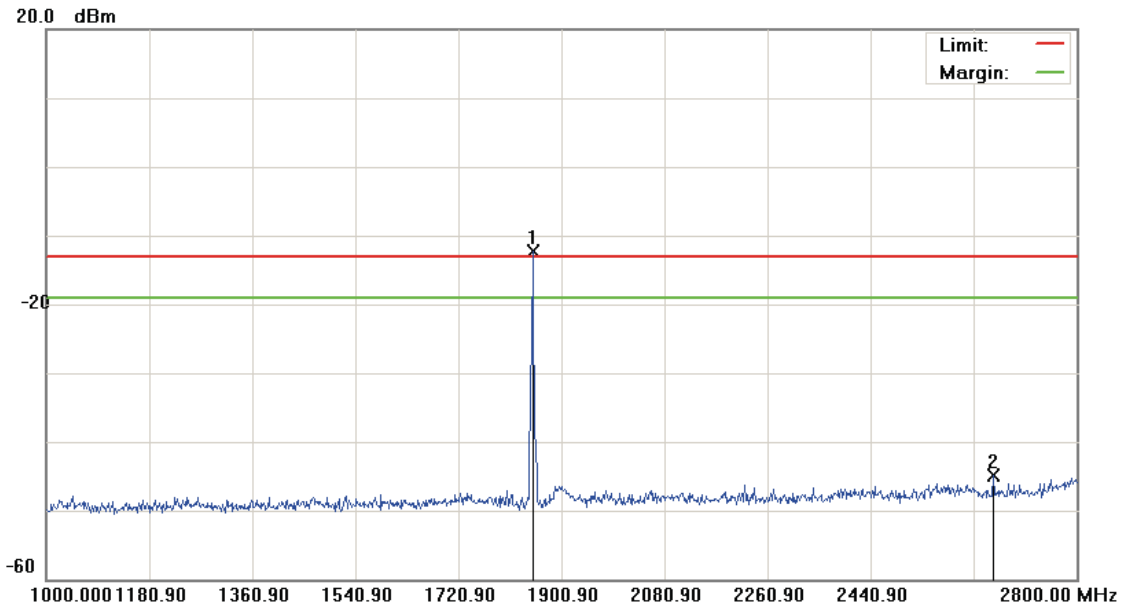

Site: : RF Conducted	Polarization: <i>Conducted po</i>	Temperature: 24.2 °C
Limit: FCC Part 24 conducted(9k-12.75G)	Power: AC 120V/60Hz	Humidity: 54 %
EUT: Smartphone	Distance:	RBW: 1000 KHz VBW: 1000 KHz
M/N: PJ03120		
Mode: PCS 1900		
Note: CH512		

No.	Mk.	Freq. MHz	Reading Level dBm	Correct Factor dB	Measure- ment dBm	Limit dBm	Over dB	Detector	Antenna Height cm	Table Degree degree	Comment
1	*	1850.500	-16.61	4.26	-12.35	-13.00	0.65	peak			Tx
2		2654.200	-49.76	4.89	-44.87	-13.00	-31.87	peak			

\*:Maximum data    x:Over limit    !:over margin

File: PJ03120(CH512)

Data: #4

Date: 2011/9/9

Time: 下午 03:29:38

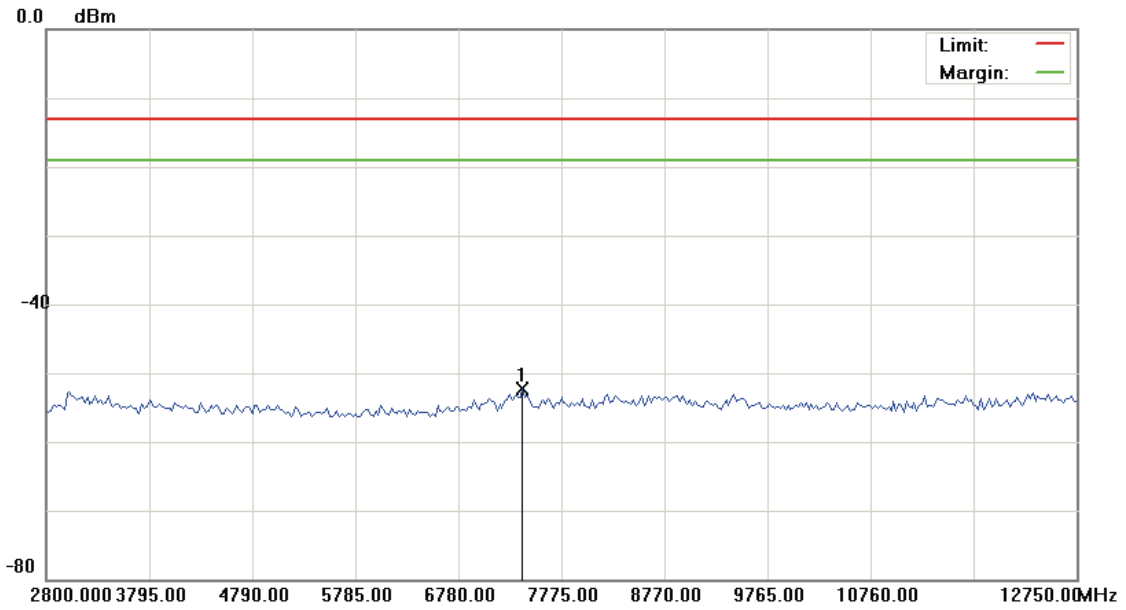

Site: : RF Conducted

 Polarization: *Conducted po*

Temperature: 24.2 °C

Limit: FCC Part 24 conducted(9k-12.75G)

Power: AC 120V/60Hz

Humidity: 54 %

EUT: Smartphone

Distance:

RBW: 1000 KHz VBW: 1000 KHz

M/N: PJ03120

Mode: PCS 1900

Note: CH512

No.	Mk.	Freq. MHz	Reading Level dBm	Correct Factor dB	Measure- ment dBm	Limit dBm	Over dB	Detector	Antenna Height cm	Table Degree degree	Comment
1	*	7401.875	-57.43	5.09	-52.34	-13.00	-39.34	peak			

\*:Maximum data    x:Over limit    !:over margin

File: PJ03120(CH512)

Data :#5

Date: 2011/9/9

Time: 下午 03:29:58

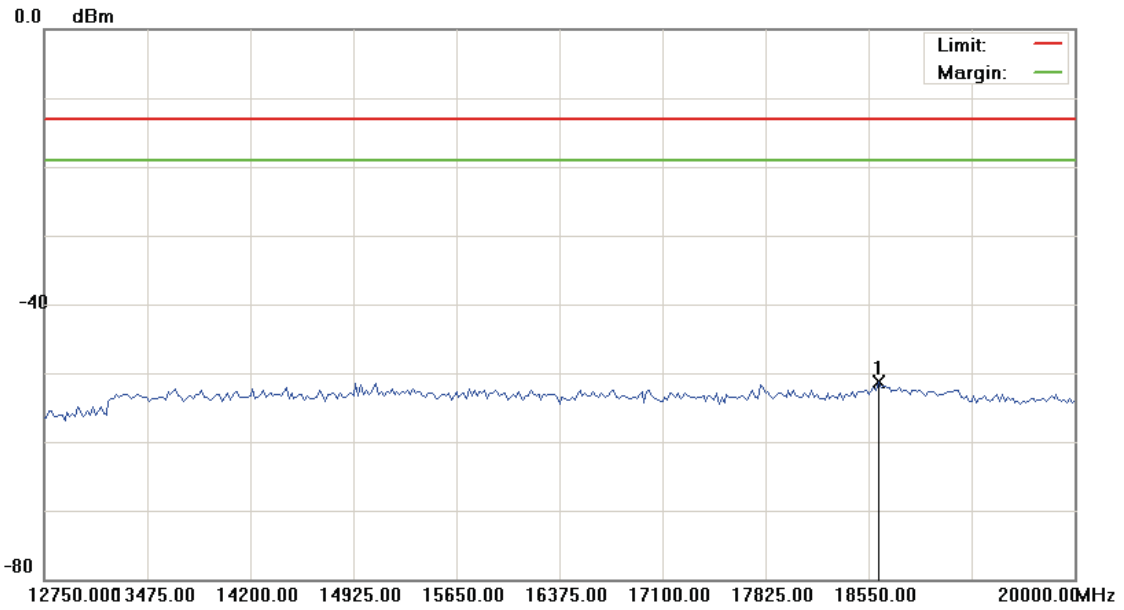

Site: : RF Conducted

 Polarization: *Conducted po*

Temperature: 24.2 °C

Limit: FCC Part 24 conducted(9k-12.75G)

Power: AC 120V/60Hz

Humidity: 54 %

EUT: Smartphone

Distance:

RBW: 1000 KHz VBW: 1000 KHz

M/N: PJ03120

Mode: PCS 1900

Note: CH512

No.	Mk.	Freq.	Reading Level	Correct Factor	Measurement	Limit	Over	Antenna Height	Table Degree	Comment	
		MHz	dBm	dB	dBm	dBm	dB	cm	degree		
1	*	18622.500	-58.33	7.05	-51.28	-13.00	-38.28	peak			

\*:Maximum data    x:Over limit    !:over margin

File: PJ03120(CH661)

Data :#1

Date: 2011/9/9

Time: 下午 03:48:46

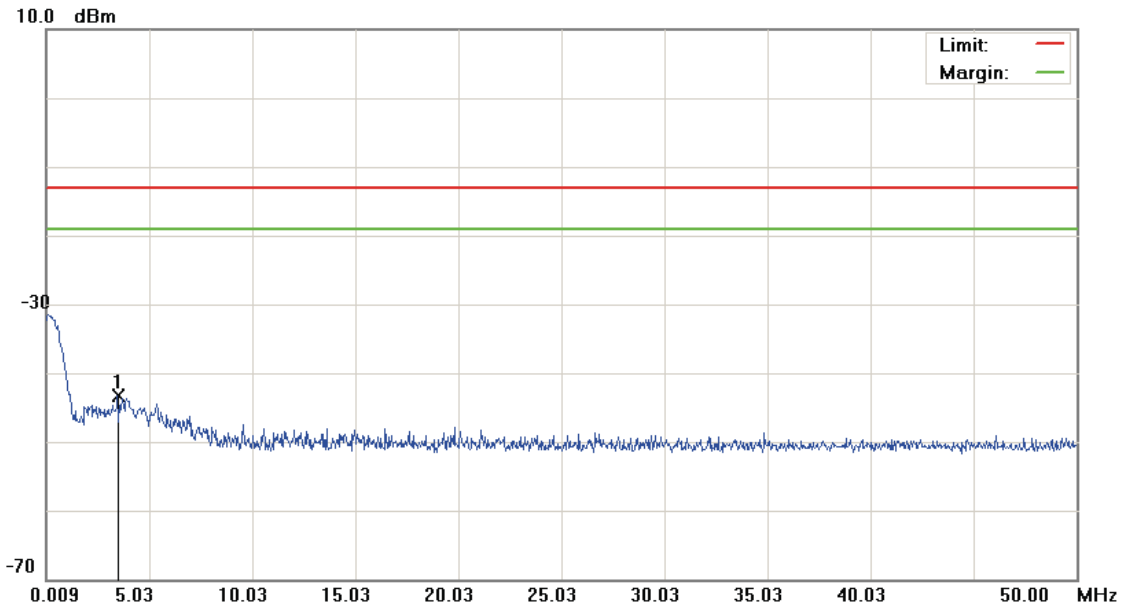

Site: : RF Conducted

 Polarization: *Conducted po*

Temperature: 24.2 °C

Limit: FCC Part 24 conducted(9k-12.75G)

Power: AC 120V/60Hz

Humidity: 54 %

EUT: Smartphone

Distance:

RBW: 1000 KHz VBW: 1000 KHz

M/N: PJ03120

Mode: PCS 1900

Note: CH661

No.	Mk.	Freq.	Reading Level	Correct Factor	Measurement	Limit	Over	Antenna Height	Table Degree	Detector	Comment
		MHz	dBm	dB	dBm	dBm	dB	cm	degree		
1	*	3.4834	-56.51	13.13	-43.38	-13.00	-30.38			peak	

\*:Maximum data    x:Over limit    !:over margin

File: PJ03120(CH661)

Data :#2

Date: 2011/9/9

Time: 下午 03:49:10

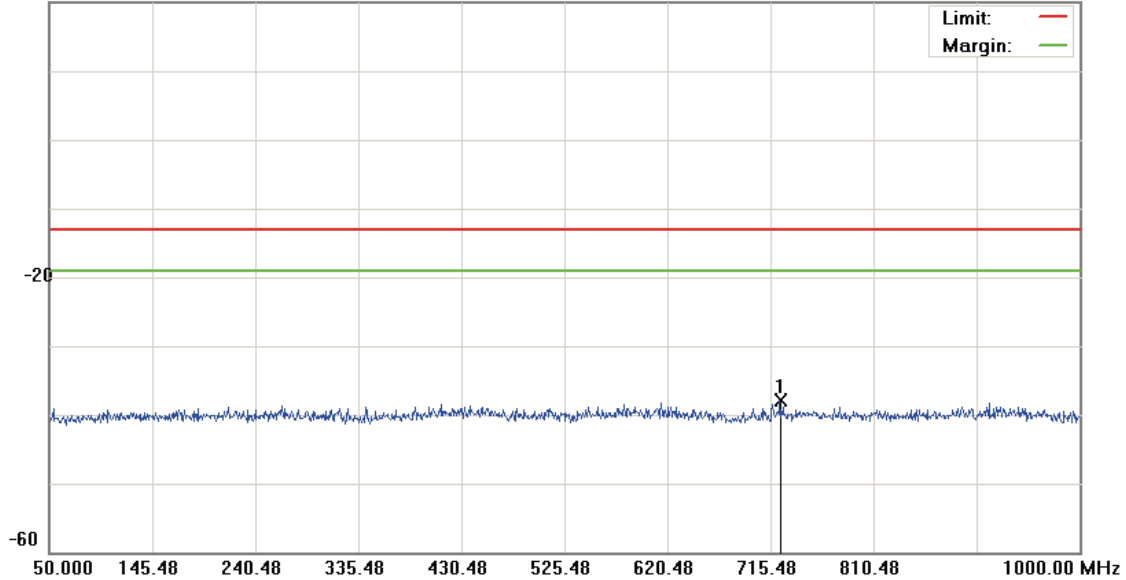
**20.0 dBm**

Site: : RF Conducted	Polarization: <i>Conducted po</i>	Temperature: 24.2 °C
Limit: FCC Part 24 conducted(9k-12.75G)	Power: AC 120V/60Hz	Humidity: 54 %
EUT: Smartphone	Distance:	RBW: 1000 KHz VBW: 1000 KHz
M/N: PJ03120		
Mode: PCS 1900		
Note: CH661		

No.	Mk.	Freq. MHz	Reading Level dBm	Correct Factor dB	Measure- ment dBm	Limit dBm	Over dB	Antenna Height cm	Table Degree degree	Comment
1	*	724.0250	-51.07	13.13	-37.94	-13.00	-24.94	peak		

\*:Maximum data    x:Over limit    !:over margin



File: PJ03120(CH661)

Data: #3

Date: 2011/9/9

Time: 下午 04:05:20

20.0 dBm

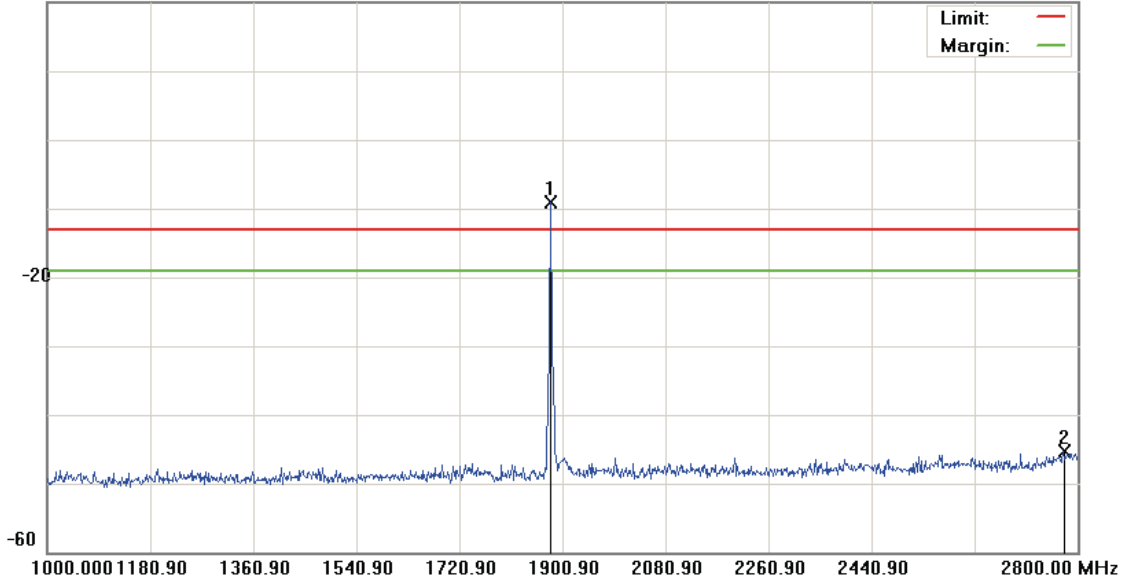

Site: : RF Conducted	Polarization: <i>Conducted po</i>	Temperature: 24.2 °C
Limit: FCC Part 24 conducted(9k-12.75G)	Power: AC 120V/60Hz	Humidity: 54 %
EUT: Smartphone	Distance:	RBW: 1000 KHz VBW: 1000 KHz
M/N: PJ03120		
Mode: PCS 1900		
Note: CH661		

No.	Mk.	Freq. MHz	Reading Level dBm	Correct Factor dB	Measure- ment dBm	Limit dBm	Over dB	Detector	Antenna Height cm	Table Degree degree	Comment
1	*	1880.200	-13.70	4.65	-9.05	-13.00	3.95	peak			Tx
2		2775.700	-51.08	5.82	-45.26	-13.00	-32.26	peak			

\*:Maximum data    x:Over limit    !:over margin

File: PJ03120(CH661)

Data :#4

Date: 2011/9/9

Time: 下午 04:10:15

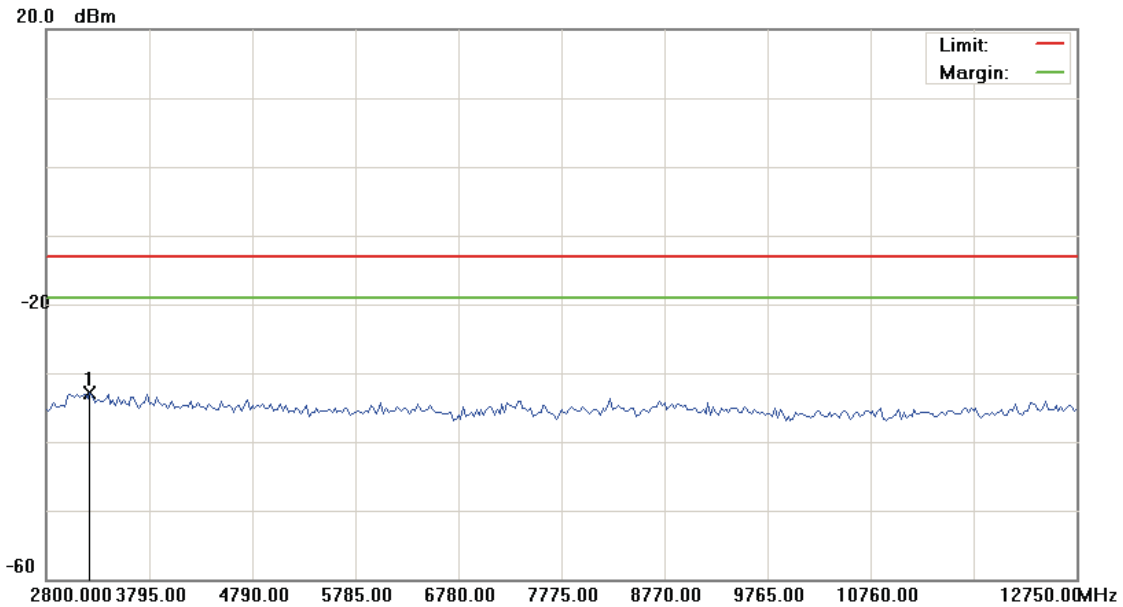

Site: : RF Conducted	Polarization: <i>Conducted po</i>	Temperature: 24.2 °C
Limit: FCC Part 24 conducted(9k-12.75G)	Power: AC 120V/60Hz	Humidity: 54 %
EUT: Smartphone	Distance:	RBW: 1000 KHz VBW: 1000 KHz
M/N: PJ03120		
Mode: PCS 1900		
Note: CH661		

No.	Mk.	Freq. MHz	Reading Level dBm	Correct Factor dB	Measure- ment dBm	Limit dBm	Over dB	Detector	Antenna Height cm	Table Degree degree	Comment
1	*	3222.875	-38.14	5.17	-32.97	-13.00	-19.97	peak			

\*:Maximum data    x:Over limit    !:over margin

File: PJ03120(CH661)

Data :#5

Date: 2011/9/9

Time: 下午 04:10:35

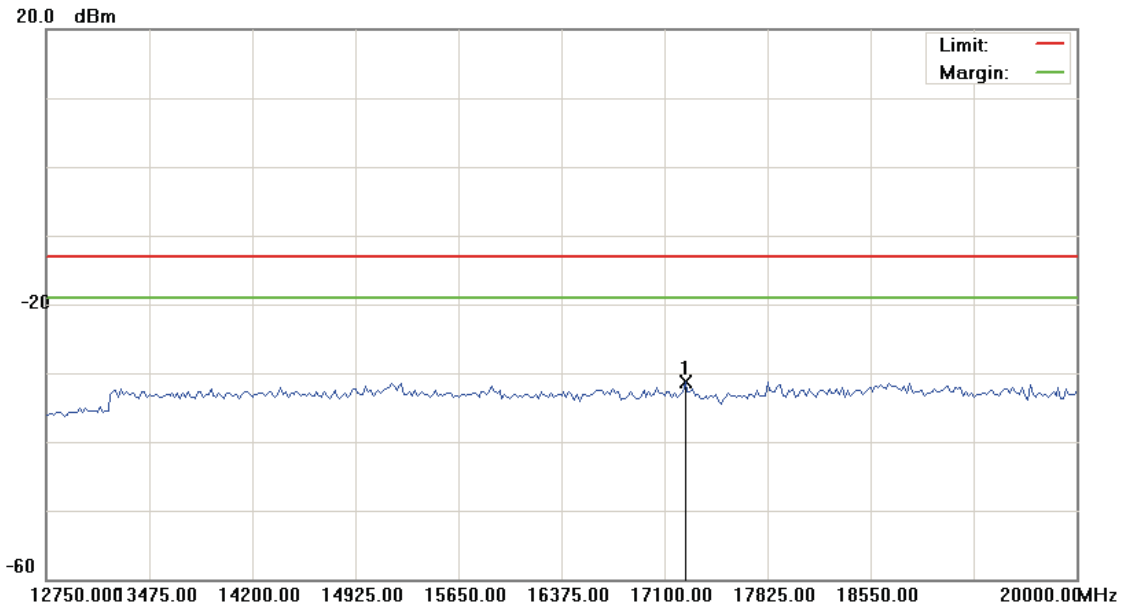

Site: : RF Conducted	Polarization: <i>Conducted po</i>	Temperature: 24.1 °C
Limit: FCC Part 24 conducted(9k-12.75G)	Power: AC 120V/60Hz	Humidity: 54 %
EUT: Smartphone	Distance:	RBW: 1000 KHz VBW: 1000 KHz
M/N: PJ03120		
Mode: PCS 1900		
Note: CH661		

No.	Mk.	Freq.	Reading Level	Correct Factor	Measurement	Limit	Over	Antenna Height	Table Degree	Detector	Comment
		MHz	dBm	dB	dBm	dBm	dB	cm	degree		
1	*	17245.000	-37.87	6.65	-31.22	-13.00	-18.22			peak	

\*:Maximum data x:Over limit !:over margin

File: PJ03120(CH810)

Data :#1

Date: 2011/9/9

Time: 下午 04:18:23

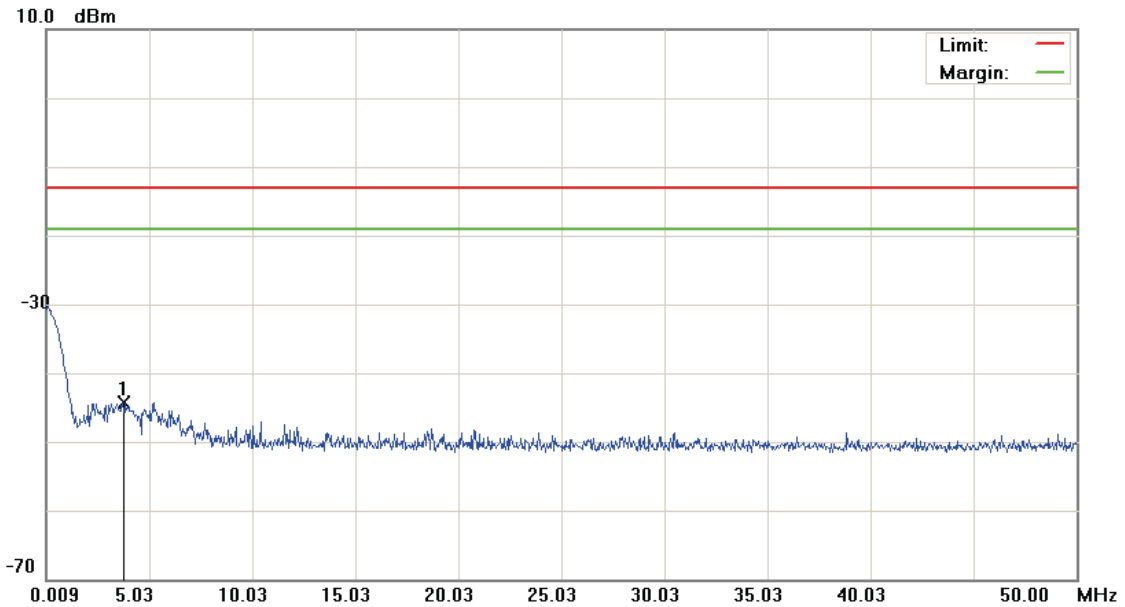

Site: : RF Conducted	Polarization: <i>Conducted po</i>	Temperature: 24.2 °C
Limit: FCC Part 24 conducted(9k-12.75G)	Power: AC 120V/60Hz	Humidity: 54 %
EUT: Smartphone	Distance:	RBW: 1000 KHz VBW: 1000 KHz
M/N: PJ03120		
Mode: PCS 1900		
Note: CH810		

No.	Mk.	Freq. MHz	Reading Level dBm	Correct Factor dB	Measure- ment dBm	Limit dBm	Over dB	Antenna Height cm	Table Degree degree	Detector	Comment
1	*	3.7332	-57.38	13.18	-44.20	-13.00	-31.20			peak	

\*:Maximum data    x:Over limit    !:over margin

File: PJ03120(CH810)

Data :#2

Date: 2011/9/9

Time: 下午 04:18:47

20.0 dBm

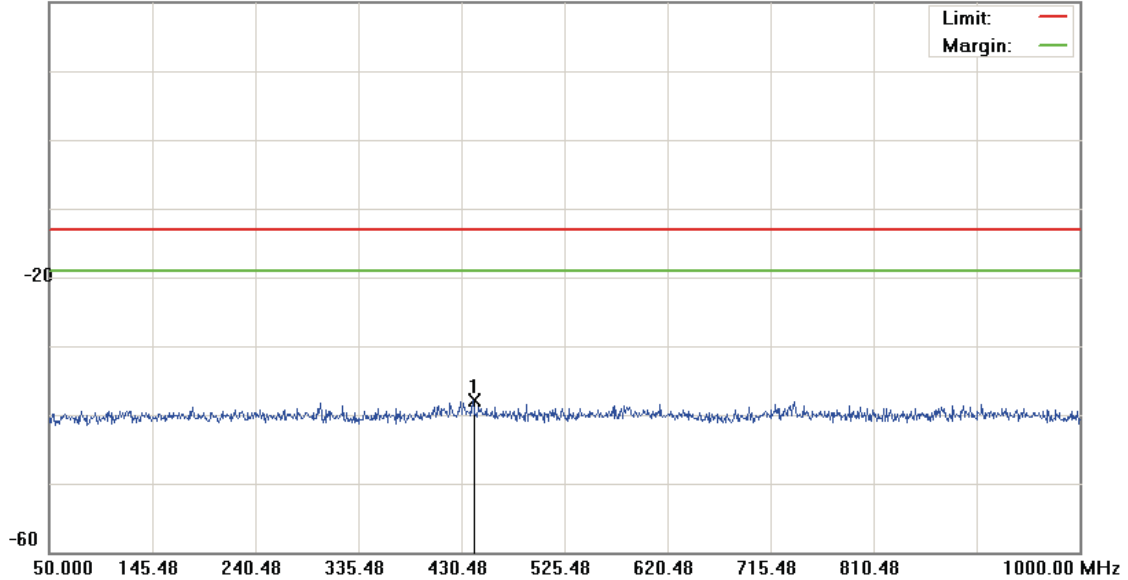

Site: : RF Conducted	Polarization: <i>Conducted po</i>	Temperature: 24.2 °C
Limit: FCC Part 24 conducted(9k-12.75G)	Power: AC 120V/60Hz	Humidity: 54 %
EUT: Smartphone	Distance:	RBW: 1000 KHz VBW: 1000 KHz
M/N: PJ03120		
Mode: PCS 1900		
Note: CH810		

No.	Mk.	Freq.	Reading Level	Correct Factor	Measurement	Limit	Over	Antenna Height	Table Degree	Detector	Comment
		MHz	dBm	dB	dBm	dBm	dB	cm	degree		
1	*	440.9250	-51.15	13.20	-37.95	-13.00	-24.95			peak	

\*:Maximum data    x:Over limit    !:over margin

File: PJ03120(CH810)

Data :#3

Date: 2011/9/9

Time: 下午 04:20:06

20.0 dBm

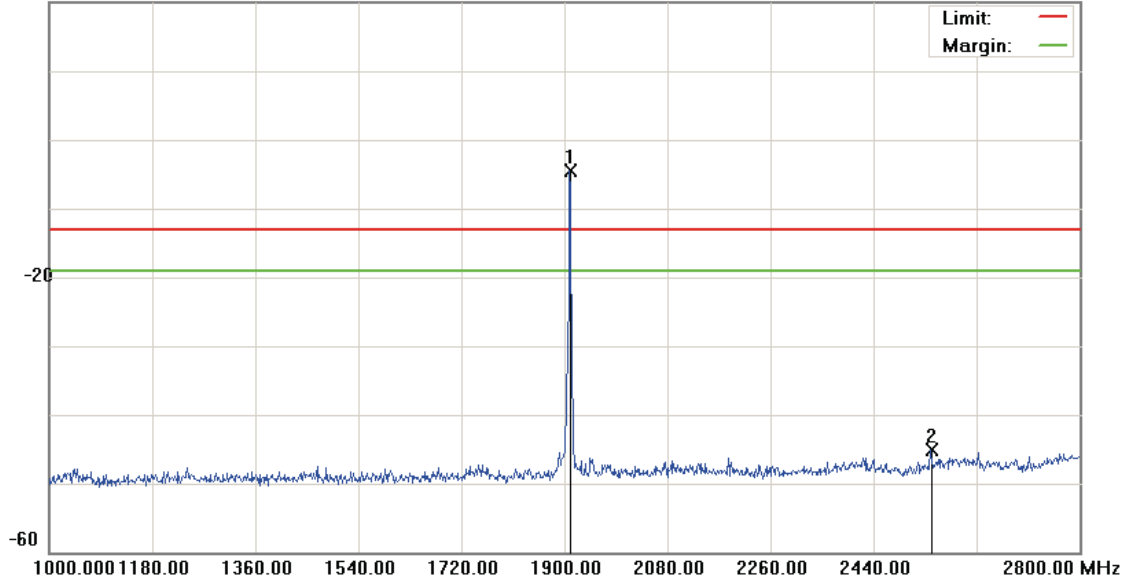

Site: : RF Conducted	Polarization: <i>Conducted po</i>	Temperature: 24.2 °C
Limit: FCC Part 24 conducted(9k-12.75G)	Power: AC 120V/60Hz	Humidity: 54 %
EUT: Smartphone	Distance:	RBW: 1000 KHz VBW: 1000 KHz
M/N: PJ03120		
Mode: PCS 1900		
Note: CH810		

No.	Mk.	Freq. MHz	Reading Level dBm	Correct Factor dB	Measure- ment dBm	Limit dBm	Over dB	Detector	Antenna Height cm	Table Degree degree	Comment
1	*	1909.900	-10.28	5.71	-4.57	-13.00	8.43	peak			Tx
2		2539.900	-50.15	5.03	-45.12	-13.00	-32.12	peak			

\*:Maximum data    x:Over limit    !:over margin

File: PJ03120(CH810)

Data :#4

Date: 2011/9/9

Time: 下午 04:24:08

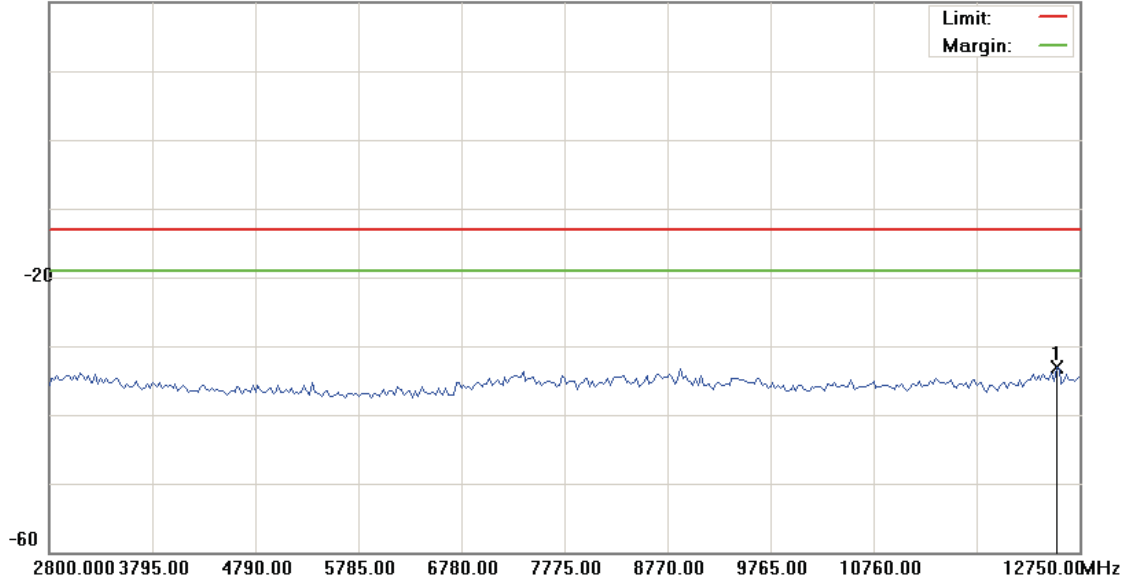
**20.0 dBm**

Site: : RF Conducted	Polarization: <i>Conducted po</i>	Temperature: 24.2 °C
Limit: FCC Part 24 conducted(9k-12.75G)	Power: AC 120V/60Hz	Humidity: 54 %
EUT: Smartphone	Distance:	RBW: 1000 KHz VBW: 1000 KHz
M/N: PJ03120		
Mode: PCS 1900		
Note: CH810		

No.	Mk.	Freq. MHz	Reading Level dBm	Correct Factor dB	Measure- ment dBm	Limit dBm	Over dB	Detector	Antenna Height cm	Table Degree degree	Comment
1	*	12526.125	-38.10	5.05	-33.05	-13.00	-20.05	peak			

\*:Maximum data    x:Over limit    !:over margin

File: PJ03120(CH810)

Data :#5

Date: 2011/9/9

Time: 下午 04:24:31

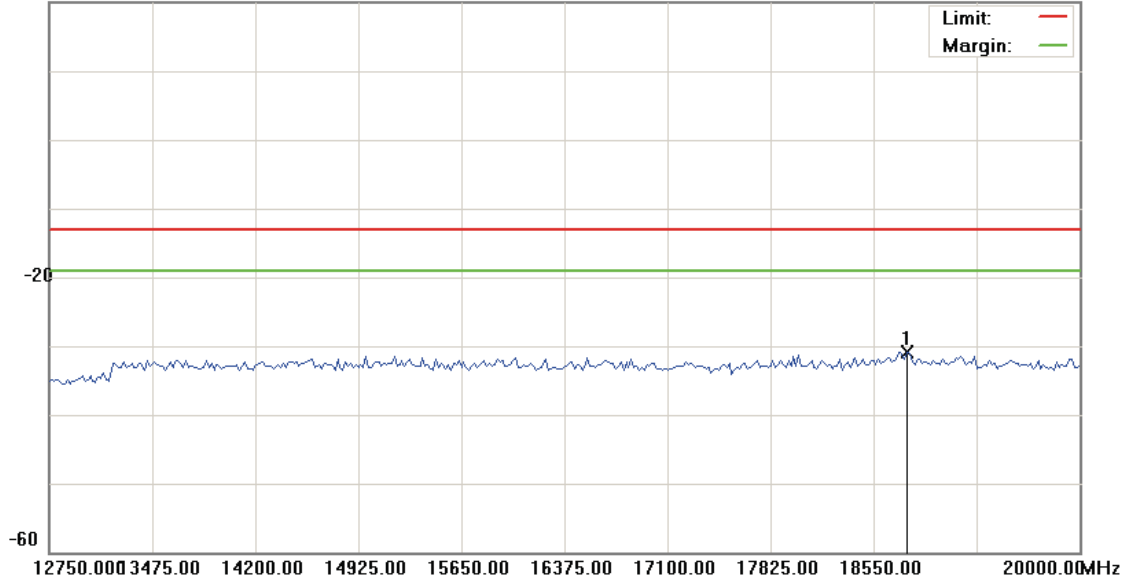
**20.0 dBm**

Site: : RF Conducted	Polarization: <i>Conducted po</i>	Temperature: 24.2 °C
Limit: FCC Part 24 conducted(9k-12.75G)	Power: AC 120V/60Hz	Humidity: 54 %
EUT: Smartphone	Distance:	RBW: 1000 KHz VBW: 1000 KHz
M/N: PJ03120		
Mode: PCS 1900		
Note: CH810		

No.	Mk.	Freq. MHz	Reading Level dBm	Correct Factor dB	Measure- ment dBm	Limit dBm	Over dB	Antenna Height cm	Table Degree degree	Comment
1	*	18785.625	-37.90	7.09	-30.81	-13.00	-17.81	peak		

\*:Maximum data    x:Over limit    !:over margin



File: PJ03120(CH9262)

Data :#1

Date: 2011/9/9

Time: 下午 05:18:20

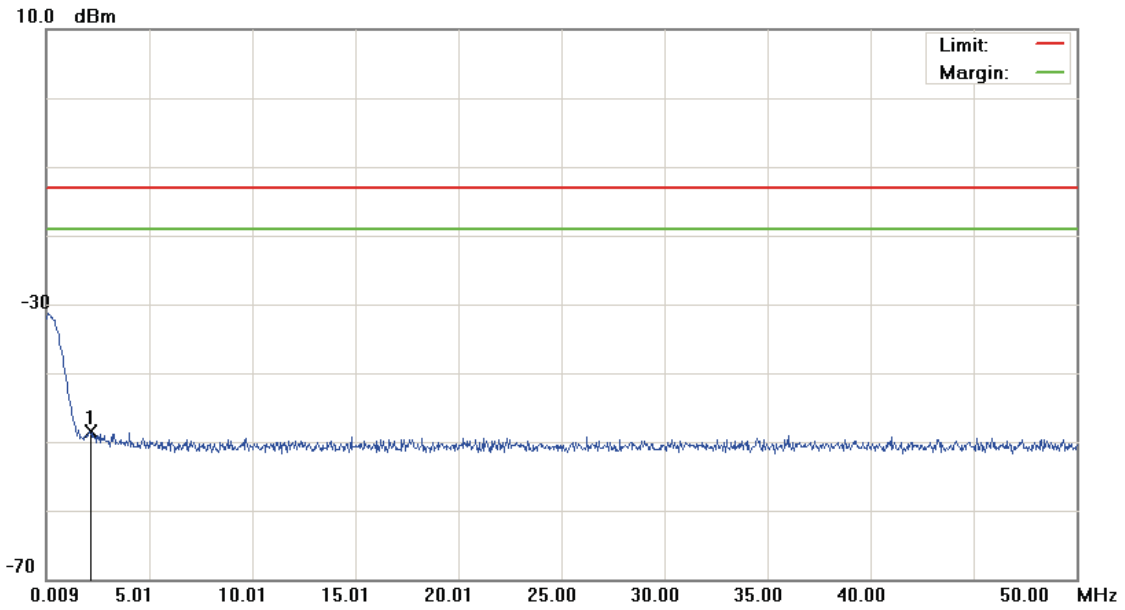

Site: : RF Conducted	Polarization: <i>Conducted po</i>	Temperature: 24.2 °C
Limit: FCC Part 24 conducted(9k-12.75G)	Power: AC 120V/60Hz	Humidity: 54 %
EUT: Smartphone	Distance:	RBW: 1000 KHz VBW: 1000 KHz
M/N: PJ03120		
Mode: WCDMA BAND II		
Note: CH9262		

No.	Mk.	Freq.	Reading Level	Correct Factor	Measurement	Limit	Over	Antenna Height	Table Degree	
		MHz	dBm	dB	dBm	dBm	dB	cm	degree	Comment
1	*	2.1335	-61.73	13.14	-48.59	-13.00	-35.59			peak

\*:Maximum data x:Over limit !:over margin

File: PJ03120(CH9262)

Data :#2

Date: 2011/9/9

Time: 下午 05:18:44

20.0 dBm

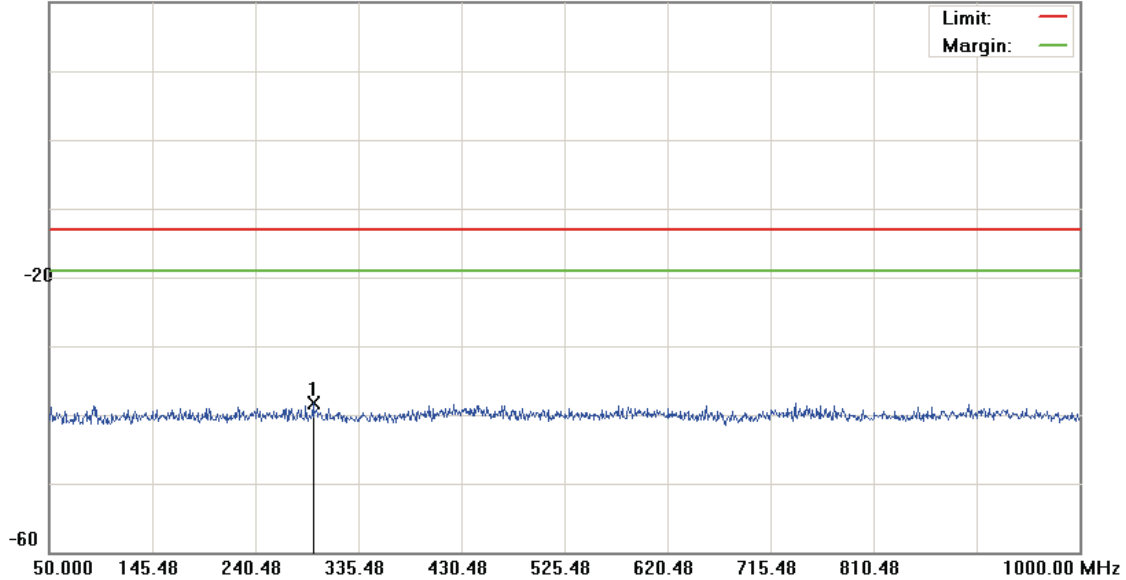

Site: : RF Conducted	Polarization: <i>Conducted po</i>	Temperature: 24.2 °C
Limit: FCC Part 24 conducted(9k-12.75G)	Power: AC 120V/60Hz	Humidity: 54 %
EUT: Smartphone	Distance:	RBW: 1000 KHz VBW: 1000 KHz
M/N: PJ03120		
Mode: WCDMA BAND II		
Note: CH9262		

No.	Mk.	Freq. MHz	Reading Level dBm	Correct Factor dB	Measure- ment dBm	Limit dBm	Over dB	Antenna Height cm	Table Degree degree	Comment
1	*	293.6750	-51.58	13.29	-38.29	-13.00	-25.29	peak		

\*:Maximum data    x:Over limit    !:over margin

File: PJ03120(CH9262)

Data :#3

Date: 2011/9/9

Time: 下午 05:29:48

20.0 dBm

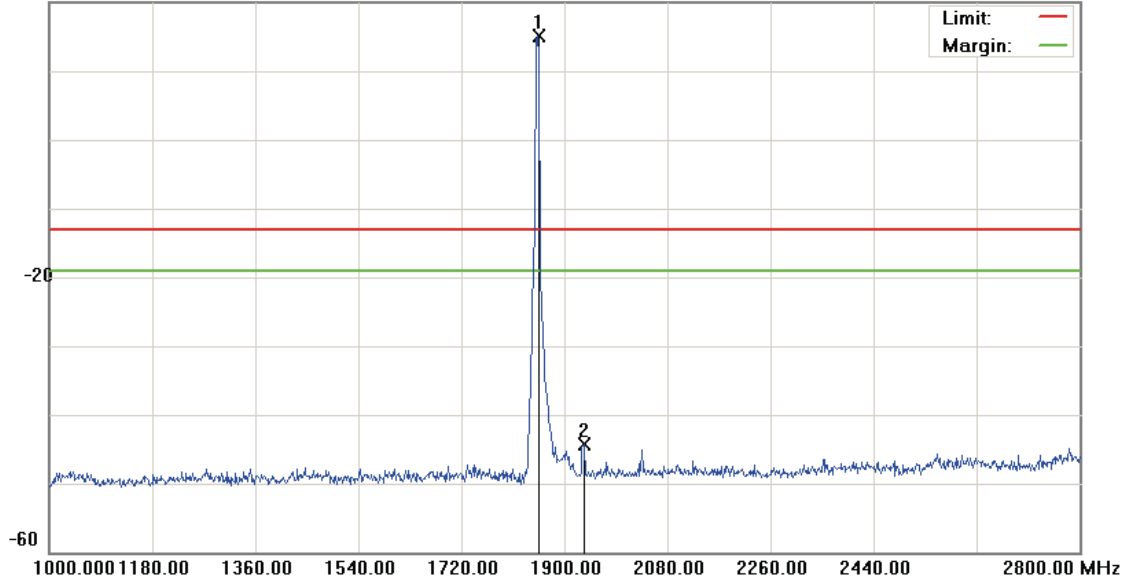

Site: : RF Conducted	Polarization: <i>Conducted po</i>	Temperature: 24.2 °C
Limit: FCC Part 24 conducted(9k-12.75G)	Power: AC 120V/60Hz	Humidity: 54 %
EUT: Smartphone	Distance:	RBW: 1000 KHz VBW: 1000 KHz
M/N: PJ03120		
Mode: WCDMA BAND II		
Note: CH9262		

No.	Mk.	Freq. MHz	Reading Level dBm	Correct Factor dB	Measure- ment dBm	Limit dBm	Over dB	Detector	Antenna Height cm	Table Degree degree	Comment
1	*	1854.100	10.73	4.28	15.01	-13.00	28.01	peak			Tx
2		1934.200	-48.96	4.65	-44.31	-13.00	-31.31	peak			

\*:Maximum data    x:Over limit    !:over margin

File :PJ03120(CH9262)

Data :#4

Date:2011/9/9

Time: 下午 05:58:38

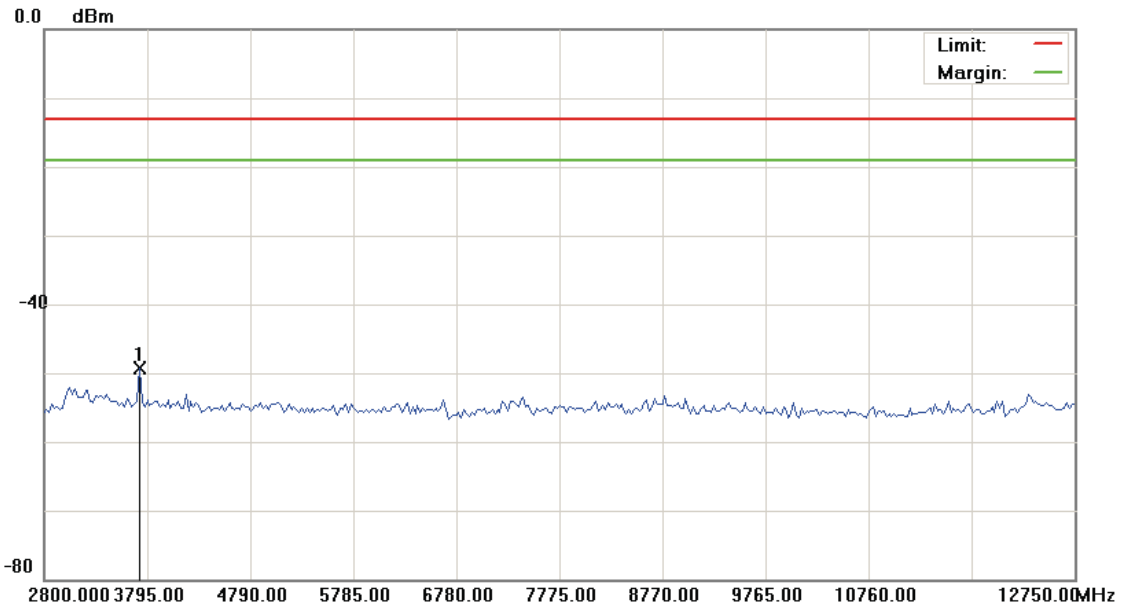

Site : RF Conducted

 Polarization: *Conducted po*

Temperature: 24.2 °C

Limit: FCC Part 24 conducted(9k-12.75G)

Power: AC 120V/60Hz

Humidity: 54 %

EUT: Smartphone

Distance:

RBW: 1000 KHz VBW: 1000 KHz

M/N: PJ03120

Mode: WCDMA BAND II

Note: CH9262

No.	Mk.	Freq. MHz	Reading Level dBm	Correct Factor dB	Measure- ment dBm	Limit dBm	Over dB	Detector	Antenna Height cm	Table Degree degree	Comment
1	*	3720.375	-54.22	4.88	-49.34	-13.00	-36.34	peak			

\*:Maximum data    x:Over limit    !:over margin

File :PJ03120(CH9262)

Data :#5

Date:2011/9/9

Time: 下午 05:59:02

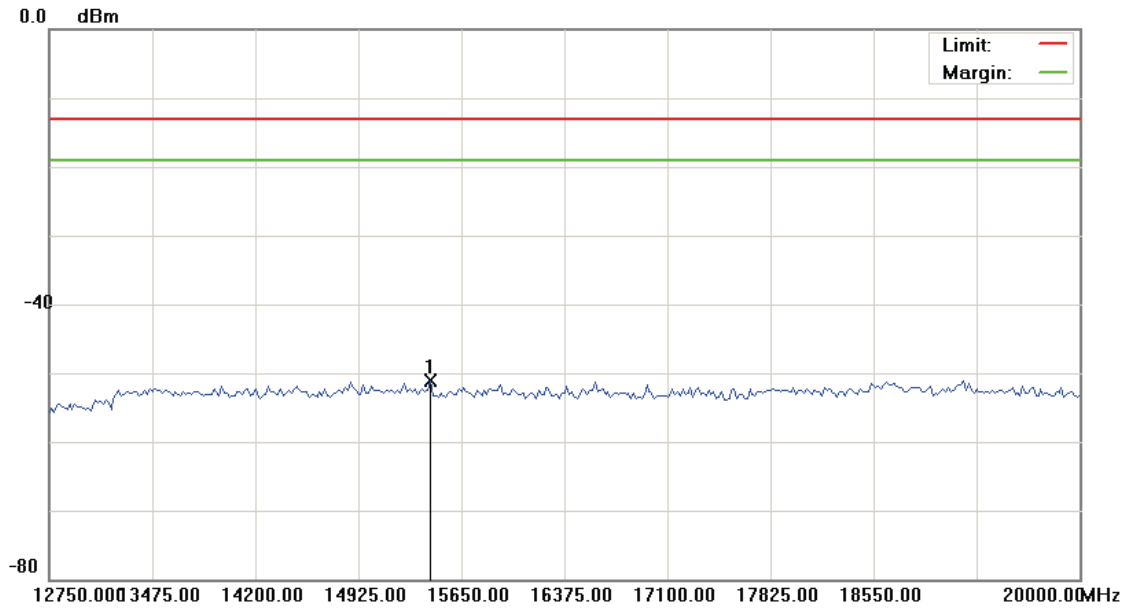

Site : RF Conducted

 Polarization: *Conducted po*

Temperature: 24.2 °C

Limit: FCC Part 24 conducted(9k-12.75G)

Power: AC 120V/60Hz

Humidity: 54 %

EUT: Smartphone

Distance:

RBW: 1000 KHz VBW: 1000 KHz

M/N: PJ03120

Mode: WCDMA BAND II

Note: CH9262

No.	Mk.	Freq.	Reading Level	Correct Factor	Measurement	Limit	Over	Antenna Height	Table Degree	Detector	Comment
		MHz	dBm	dB	dBm	dBm	dB	cm	degree		
1	*	15432.500	-57.17	6.14	-51.03	-13.00	-38.03			peak	

\*:Maximum data    x:Over limit    !:over margin

File: PJ03120(CH9400)

Data :#1

Date: 2011/9/9

Time: 下午 05:19:37

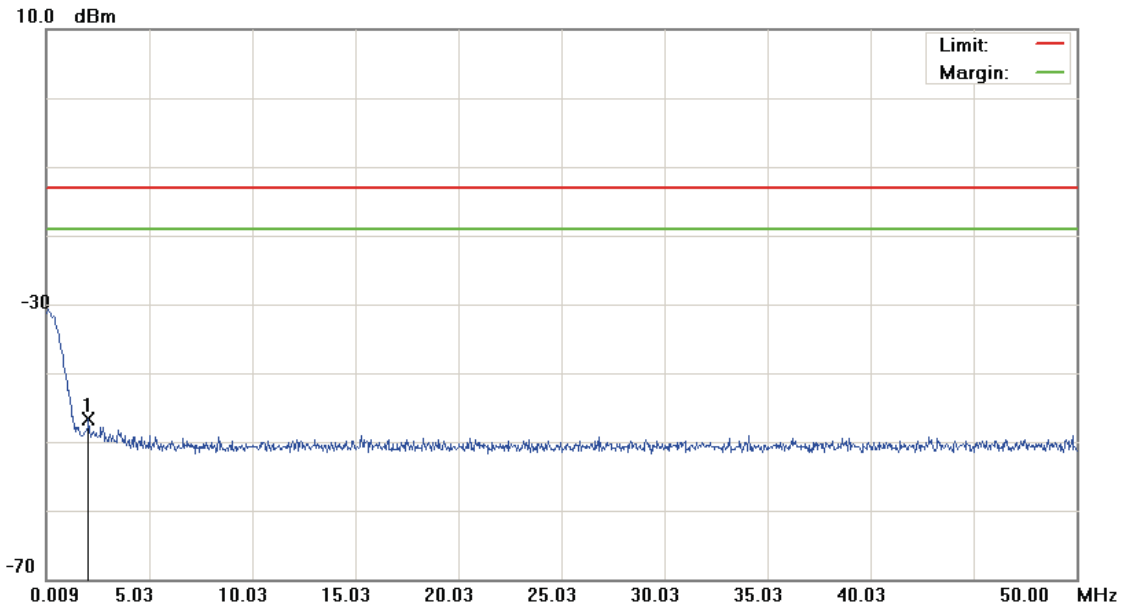

Site: : RF Conducted	Polarization: <i>Conducted po</i>	Temperature: 24.2 °C
Limit: FCC Part 24 conducted(9k-12.75G)	Power: AC 120V/60Hz	Humidity: 54 %
EUT: Smartphone	Distance:	RBW: 1000 KHz VBW: 1000 KHz
M/N: PJ03120		
Mode: WCDMA BAND II		
Note: CH9400		

No.	Mk.	Freq. MHz	Reading Level dBm	Correct Factor dB	Measure- ment dBm	Limit dBm	Over dB	Antenna Height cm	Table Degree degree	Comment
1	*	2.0586	-59.93	13.18	-46.75	-13.00	-33.75	peak		

\*:Maximum data    x:Over limit    !:over margin

File: PJ03120(CH9400)

Data :#2

Date: 2011/9/9

Time: 下午 05:20:02

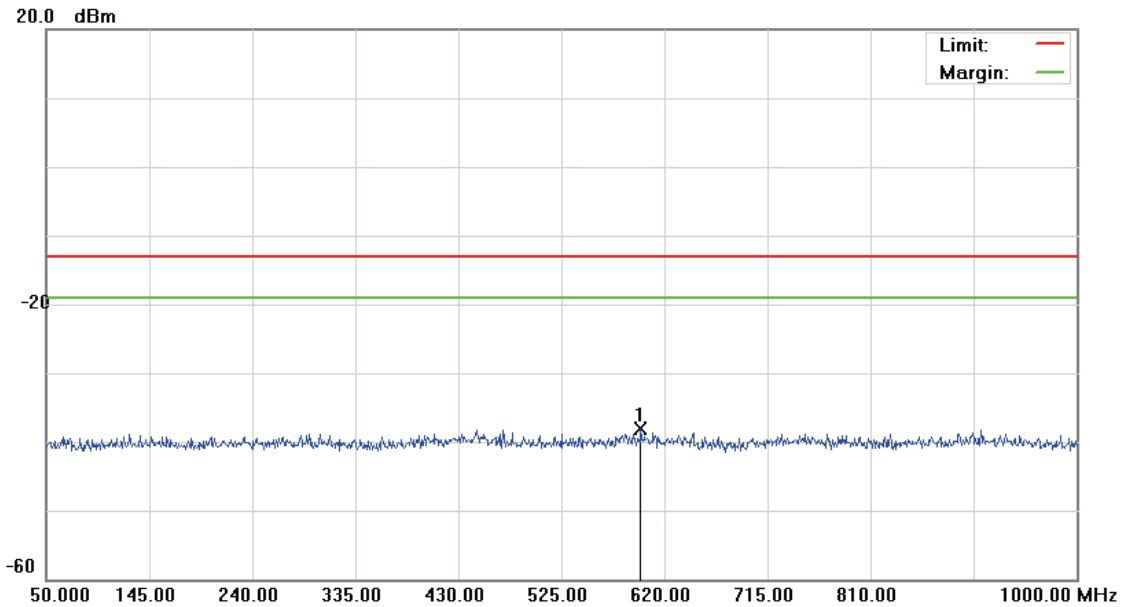

Site: : RF Conducted

 Polarization: *Conducted po*

Temperature: 24.2 °C

Limit: FCC Part 24 conducted(9k-12.75G)

Power: AC 120V/60Hz

Humidity: 54 %

EUT: Smartphone

Distance:

RBW: 1000 KHz VBW: 1000 KHz

M/N: PJ03120

Mode: WCDMA BAND II

Note: CH9400

No.	Mk.	Freq.	Reading Level	Correct Factor	Measurement	Limit	Over	Antenna Height	Table Degree	Detector	Comment
		MHz	dBm	dB	dBm	dBm	dB	cm	degree		
1	*	598.1500	-51.36	13.19	-38.17	-13.00	-25.17			peak	

\*:Maximum data    x:Over limit    !:over margin

File: PJ03120(CH9400)

Data :#3

Date: 2011/9/9

Time: 下午 05:27:36

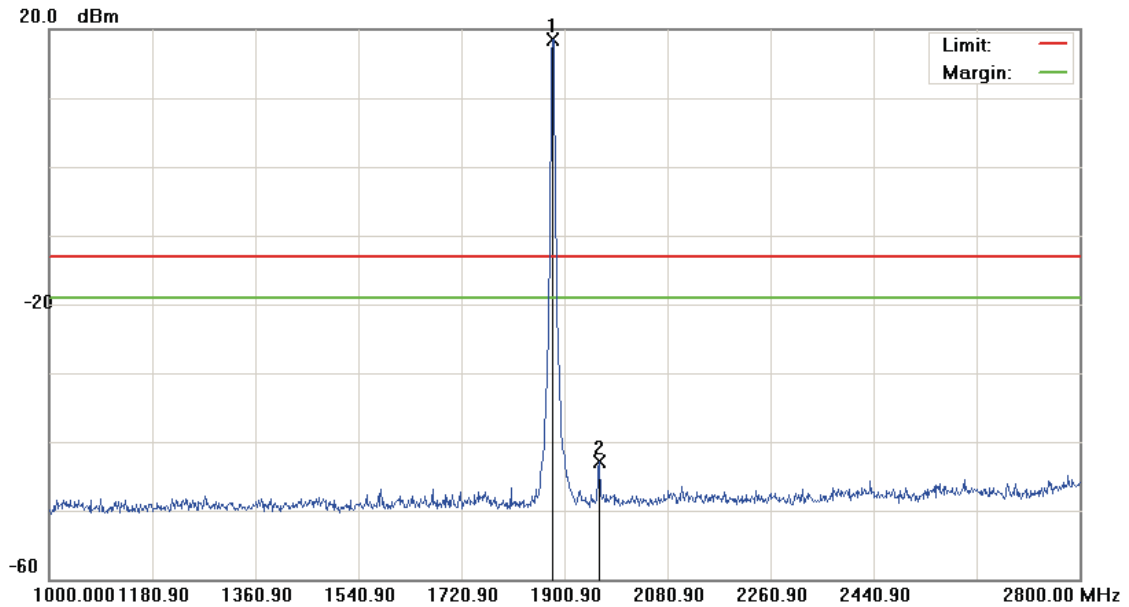

Site: : RF Conducted	Polarization: <i>Conducted po</i>	Temperature: 24.2 °C
Limit: FCC Part 24 conducted(9k-12.75G)	Power: AC 120V/60Hz	Humidity: 54 %
EUT: Smartphone	Distance:	RBW: 1000 KHz VBW: 1000 KHz
M/N: PJ03120		
Mode: WCDMA BAND II		
Note: CH9400		

No.	Mk.	Freq. MHz	Reading Level dBm	Correct Factor dB	Measure- ment dBm	Limit dBm	Over dB	Detector	Antenna Height cm	Table Degree degree	Comment
1	*	1878.400	13.85	4.61	18.46	-13.00	31.46	peak			Tx
2		1961.200	-47.61	4.73	-42.88	-13.00	-29.88	peak			

\*:Maximum data    x:Over limit    !:over margin



File: PJ03120(CH9400)

Data :#4

Date: 2011/9/9

Time: 下午 05:59:51

20.0 dBm

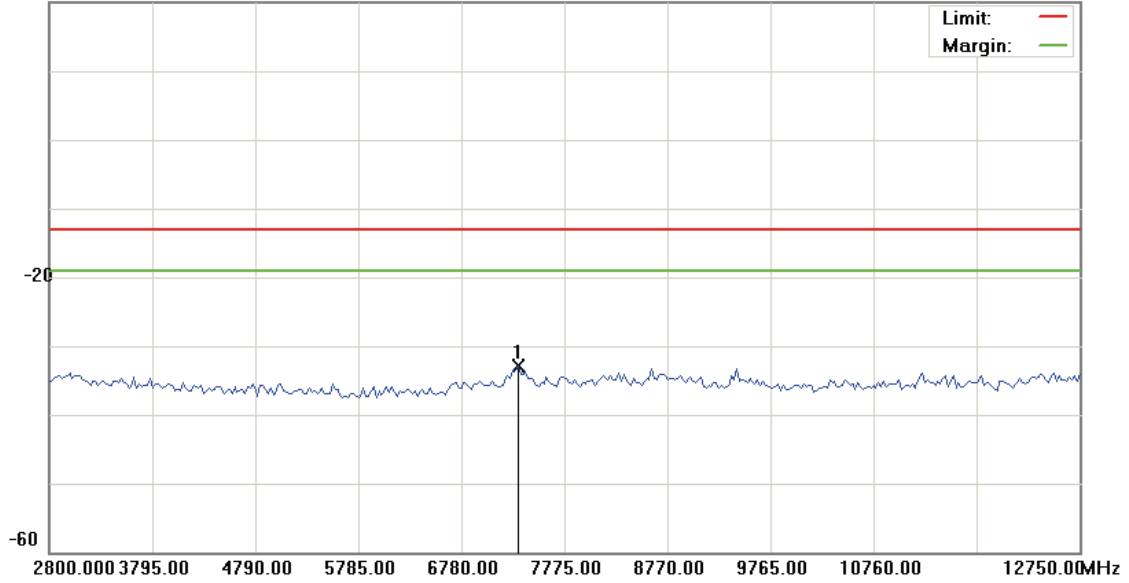

Site: : RF Conducted	Polarization: <i>Conducted po</i>	Temperature: 24.2 °C
Limit: FCC Part 24 conducted(9k-12.75G)	Power: AC 120V/60Hz	Humidity: 54 %
EUT: Smartphone	Distance:	RBW: 1000 KHz VBW: 1000 KHz
M/N: PJ03120		
Mode: WCDMA BAND II		
Note: CH9400		

No.	Mk.	Freq. MHz	Reading Level dBm	Correct Factor dB	Measure- ment dBm	Limit dBm	Over dB	Detector	Antenna Height cm	Table Degree degree	Comment
1	*	7327.250	-38.13	5.18	-32.95	-13.00	-19.95	peak			

\*:Maximum data    x:Over limit    !:over margin

File: PJ03120(CH9400)

Data :#5

Date: 2011/9/9

Time: 下午 06:00:15

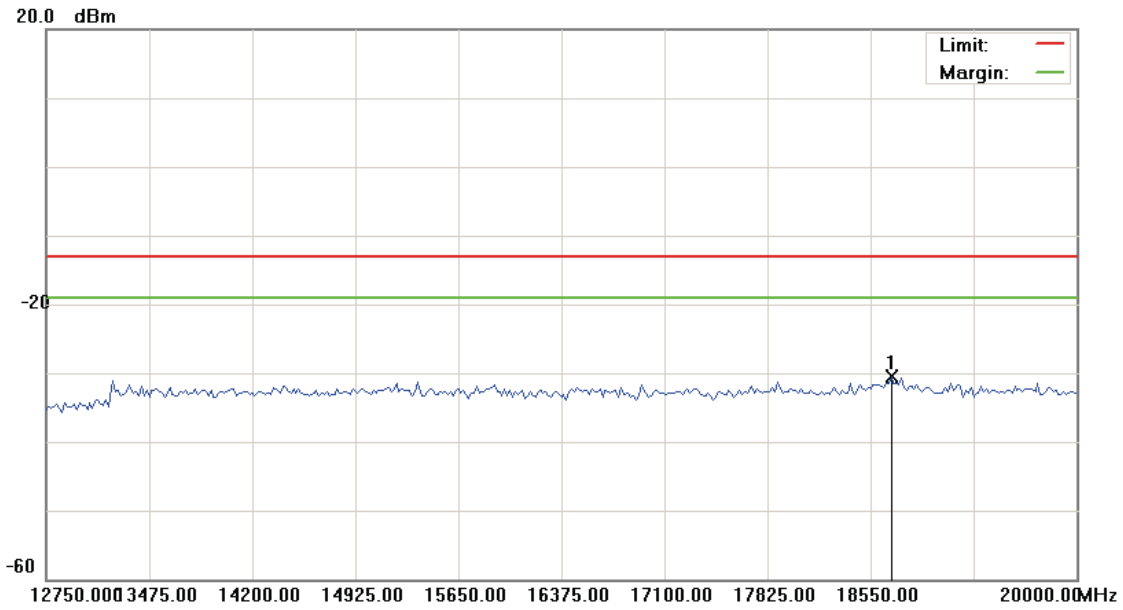

Site: : RF Conducted

 Polarization: *Conducted po*

Temperature: 24.2 °C

Limit: FCC Part 24 conducted(9k-12.75G)

Power: AC 120V/60Hz

Humidity: 54 %

EUT: Smartphone

Distance:

RBW: 1000 KHz VBW: 1000 KHz

M/N: PJ03120

Mode: WCDMA BAND II

Note: CH9400

No.	Mk.	Freq. MHz	Reading Level dBm	Correct Factor dB	Measure- ment dBm	Limit dBm	Over dB	Detector	Antenna Height cm	Table Degree degree	Comment
1	*	18695.000	-37.64	7.07	-30.57	-13.00	-17.57	peak			

\*:Maximum data    x:Over limit    !:over margin

File: PJ03120(CH9538)

Data :#1

Date: 2011/9/9

Time: 下午 05:20:58

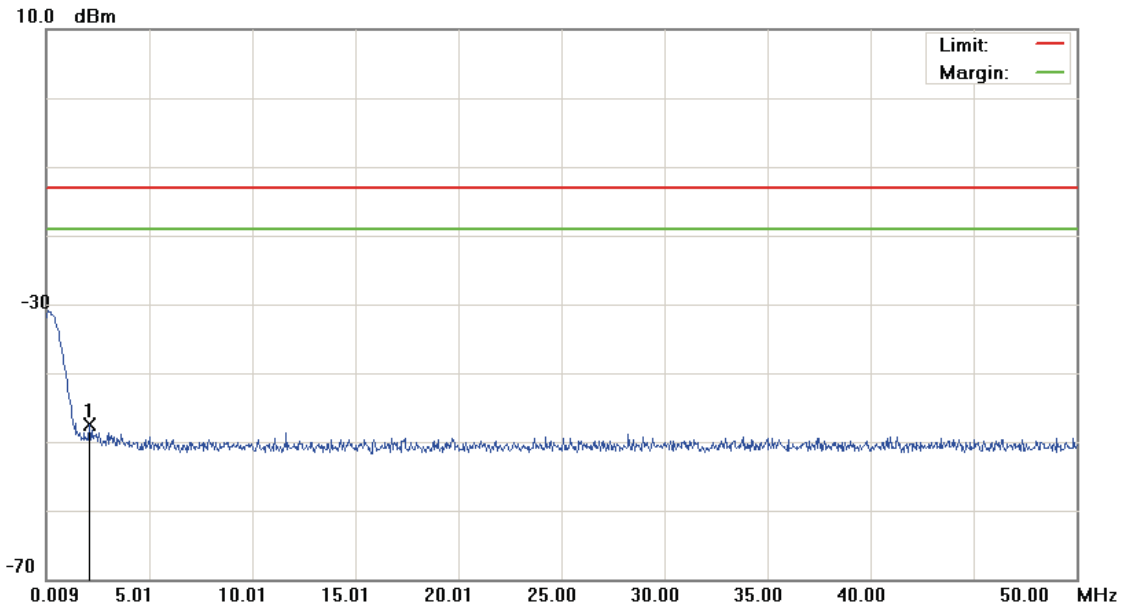

Site: : RF Conducted	Polarization: <i>Conducted po</i>	Temperature: 24.2 °C
Limit: FCC Part 24 conducted(9k-12.75G)	Power: AC 120V/60Hz	Humidity: 54 %
EUT: Smartphone	Distance:	RBW: 1000 KHz VBW: 1000 KHz
M/N: PJ03120		
Mode: WCDMA BAND II		
Note: CH9538		

No.	Mk.	Freq. MHz	Reading Level dBm	Correct Factor dB	Measure- ment dBm	Limit dBm	Over dB	Detector	Antenna Height cm	Table Degree degree	Comment
1	*	2.1086	-60.58	13.15	-47.43	-13.00	-34.43	peak			

\*:Maximum data x:Over limit !:over margin

File: PJ03120(CH9538)

Data :#2

Date: 2011/9/9

Time: 下午 05:21:23

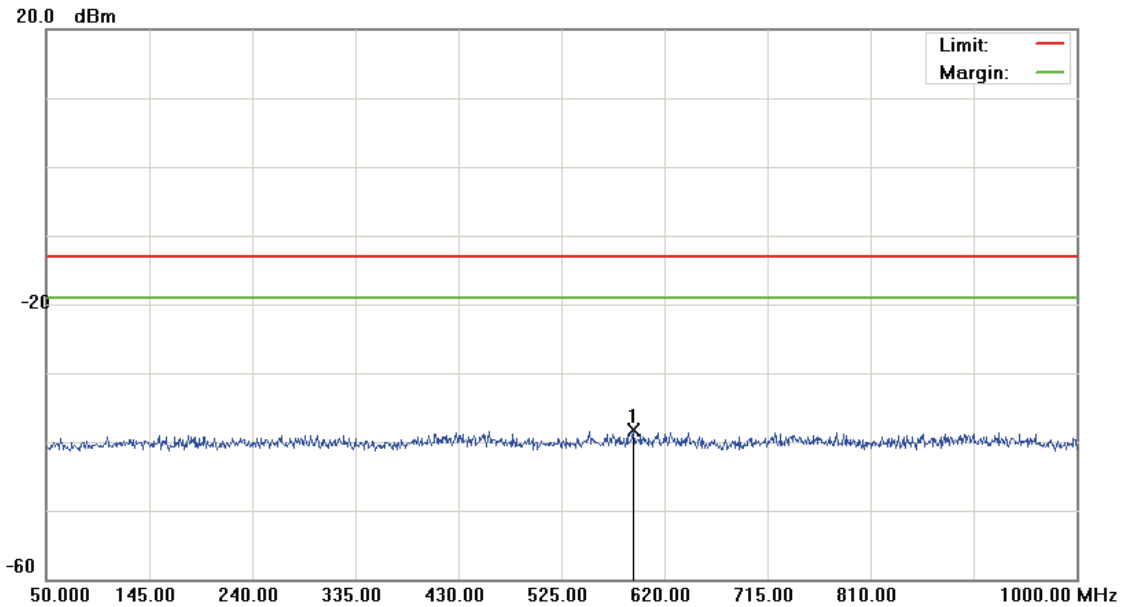

Site: : RF Conducted

 Polarization: *Conducted po*

Temperature: 24.2 °C

Limit: FCC Part 24 conducted(9k-12.75G)

Power: AC 120V/60Hz

Humidity: 54 %

EUT: Smartphone

Distance:

RBW: 1000 KHz VBW: 1000 KHz

M/N: PJ03120

Mode: WCDMA BAND II

Note: CH9538

No.	Mk.	Freq. MHz	Reading Level dBm	Correct Factor dB	Measure- ment dBm	Limit dBm	Over dB	Detector	Antenna Height cm	Table Degree degree	Comment
1	*	591.5000	-51.41	13.20	-38.21	-13.00	-25.21	peak			

\*:Maximum data    x:Over limit    !:over margin

File: PJ03120(CH9538)

Data: #3

Date: 2011/9/9

Time: 下午 05:23:28

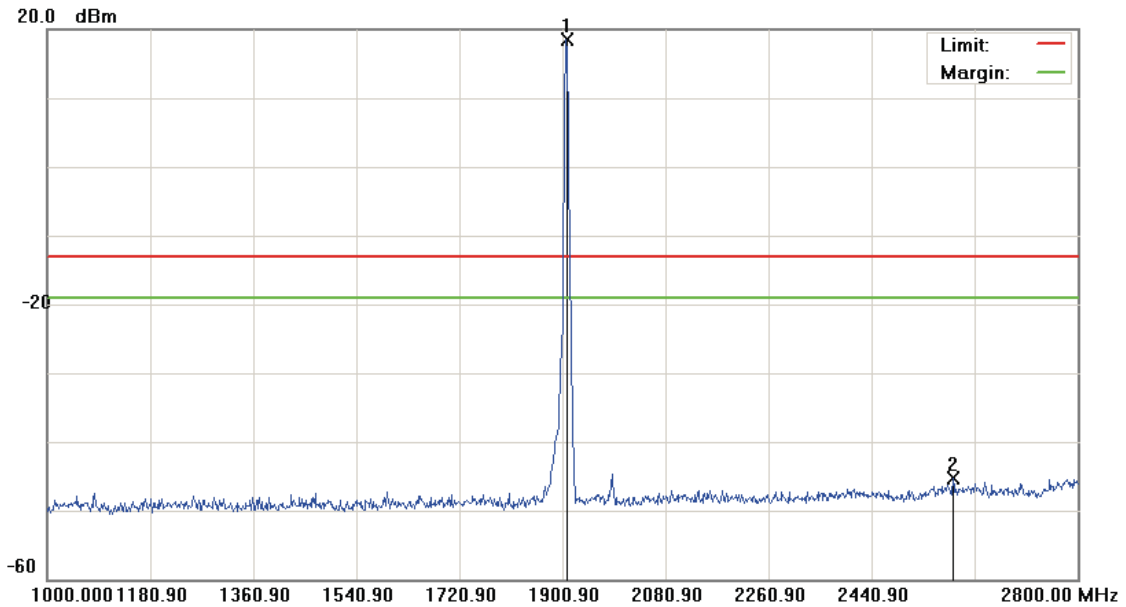

Site: : RF Conducted	Polarization: <i>Conducted po</i>	Temperature: 24.2 °C
Limit: FCC Part 24 conducted(9k-12.75G)	Power: AC 120V/60Hz	Humidity: 54 %
EUT: Smartphone	Distance:	RBW: 1000 KHz VBW: 1000 KHz
M/N: PJ03120		
Mode: WCDMA BAND II		
Note: CH9538		

No.	Mk.	Freq. MHz	Reading Level dBm	Correct Factor dB	Measure- ment dBm	Limit dBm	Over dB	Detector	Antenna Height cm	Table Degree degree	Comment
1	*	1906.300	12.54	6.05	18.59	-13.00	31.59	peak			Tx
2		2582.200	-50.65	5.36	-45.29	-13.00	-32.29	peak			

\*:Maximum data    x:Over limit    !:over margin

File: PJ03120(CH9538)

Data: #4

Date: 2011/9/9

Time: 下午 06:01:13

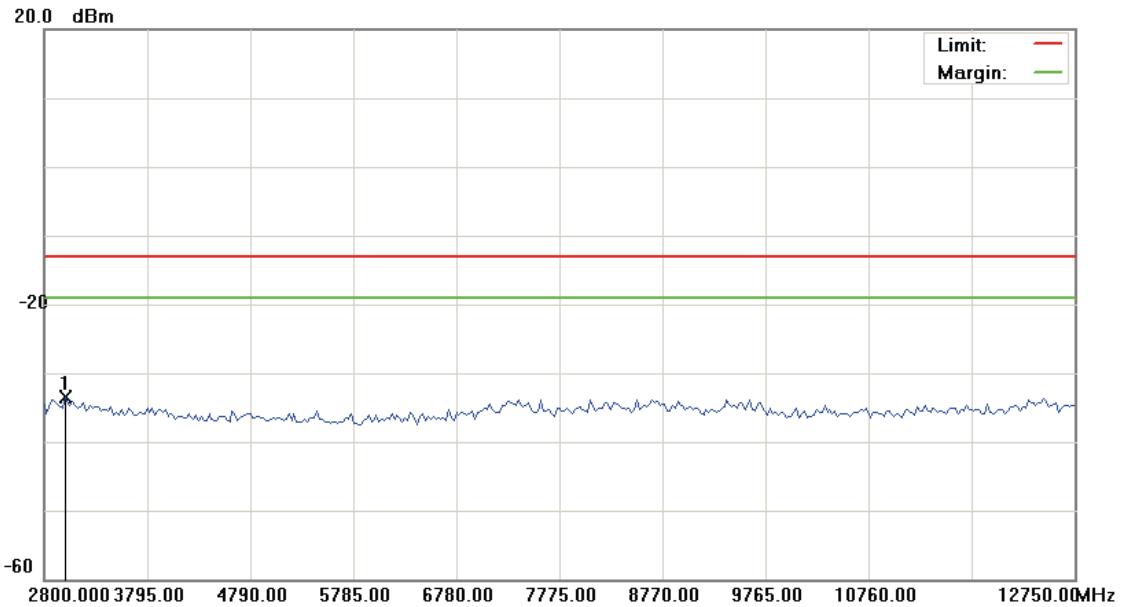

Site: : RF Conducted	Polarization: <i>Conducted po</i>	Temperature: 24.2 °C
Limit: FCC Part 24 conducted(9k-12.75G)	Power: AC 120V/60Hz	Humidity: 54 %
EUT: Smartphone	Distance:	RBW: 1000 KHz VBW: 1000 KHz
M/N: PJ03120		
Mode: WCDMA BAND II		
Note: CH9538		

No.	Mk.	Freq.	Reading Level	Correct Factor	Measurement	Limit	Over	Antenna Height	Table Degree
		MHz	dBm	dB	dBm	dBm	dB	cm	degree
1	*	2999.000	-39.00	5.48	-33.52	-13.00	-20.52	peak	

\*:Maximum data x:Over limit !:over margin

File: PJ03120(CH9538)

Data :#5

Date: 2011/9/9

Time: 下午 06:01:37

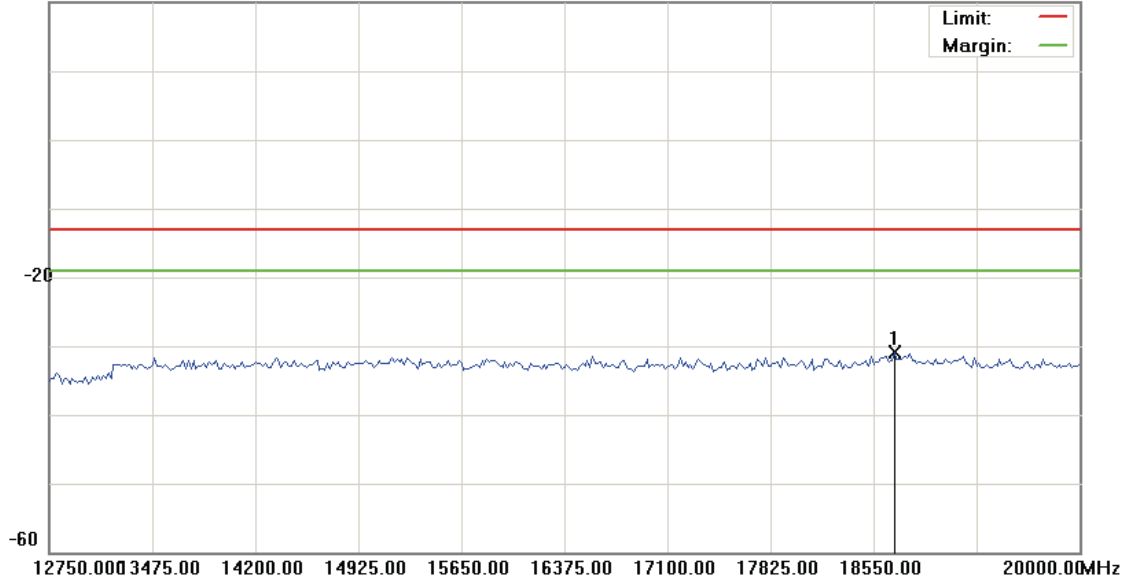
**20.0 dBm**

Site: : RF Conducted	Polarization: <i>Conducted po</i>	Temperature: 24.2 °C
Limit: FCC Part 24 conducted(9k-12.75G)	Power: AC 120V/60Hz	Humidity: 54 %
EUT: Smartphone	Distance:	RBW: 1000 KHz VBW: 1000 KHz
M/N: PJ03120		
Mode: WCDMA BAND II		
Note: CH9538		

No.	Mk.	Freq. MHz	Reading Level dBm	Correct Factor dB	Measure- ment dBm	Limit dBm	Over dB	Antenna Height cm	Table Degree degree	Detector	Comment
1	*	18695.000	-38.03	7.07	-30.96	-13.00	-17.96			peak	

\*:Maximum data    x:Over limit    !:over margin

File: PJ03120(CH4132)

Data: #1

Date: 2011/9/9

Time: 下午 05:34:04

10.0 dBm

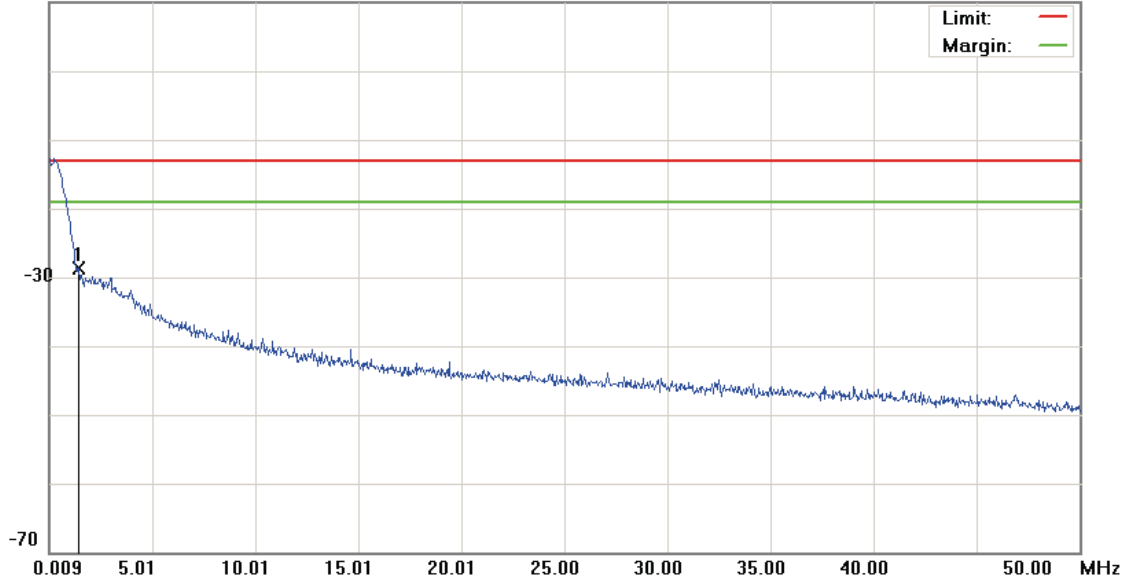

Site: : RF Conducted	Polarization: <i>Conducted po</i>	Temperature: 24.2 °C
Limit: FCC Part 22 conducted(9k-12.75G)	Power: AC 120V/60Hz	Humidity: 54 %
EUT: Smartphone	Distance:	RBW: 1000 KHz VBW: 1000 KHz
M/N: PJ03120		
Mode: WCDMA BAND V		
Note: CH4132		

No.	Mk.	Freq.	Reading Level	Correct Factor	Measurement	Limit	Over	Antenna Height	Table Degree
		MHz	dBm	dB	dBm	dBm	dB	cm	degree
1	*	1.4587	-60.13	31.40	-28.73	-13.00	-15.73	peak	

\*:Maximum data x:Over limit !:over margin



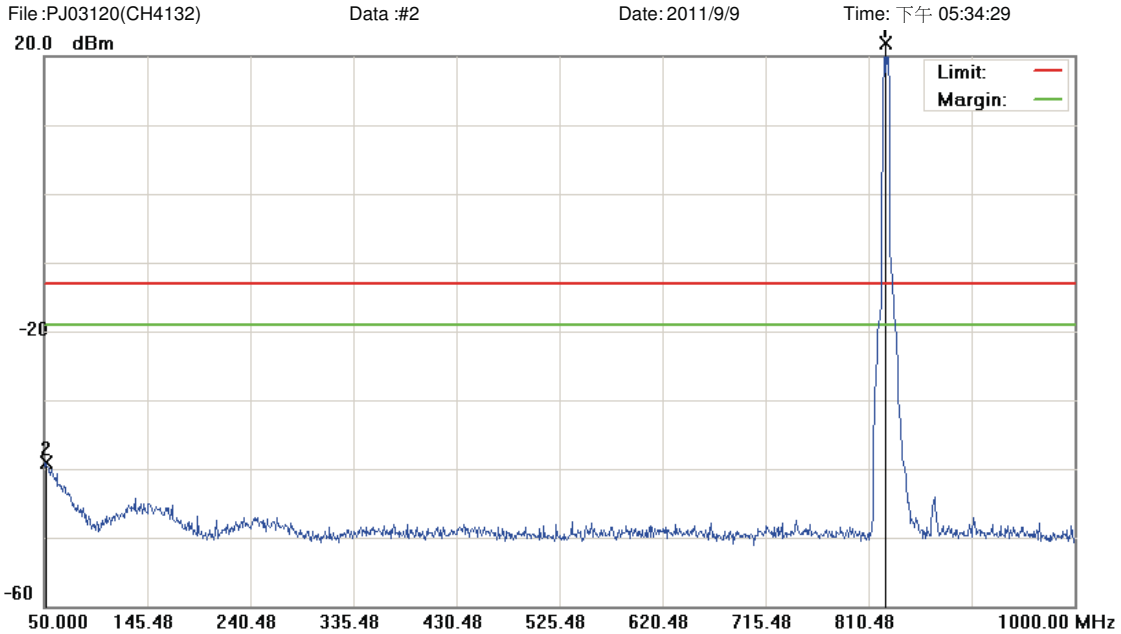

Site: : RF Conducted	Polarization: <i>Conducted po</i>	Temperature: 24.2 °C
Limit: FCC Part 22 conducted(9k-12.75G)	Power: AC 120V/60Hz	Humidity: 54 %
EUT: Smartphone	Distance:	RBW: 1000 KHz VBW: 1000 KHz
M/N: PJ03120		
Mode: WCDMA BAND V		
Note: CH4132		

No.	Mk.	Freq. MHz	Reading Level dBm	Correct Factor dB	Measure- ment dBm	Limit dBm	Over dB	Detector	Antenna Height cm	Table Degree degree	Comment
1	*	825.2000	18.07	3.84	21.91	-13.00	34.91	peak			TX
2		51.4250	-53.53	14.44	-39.09	-13.00	-26.09	peak			

\*:Maximum data    x:Over limit    !:over margin

File: PJ03120(CH4132)

Data: #3

Date: 2011/9/9

Time: 下午 05:49:40

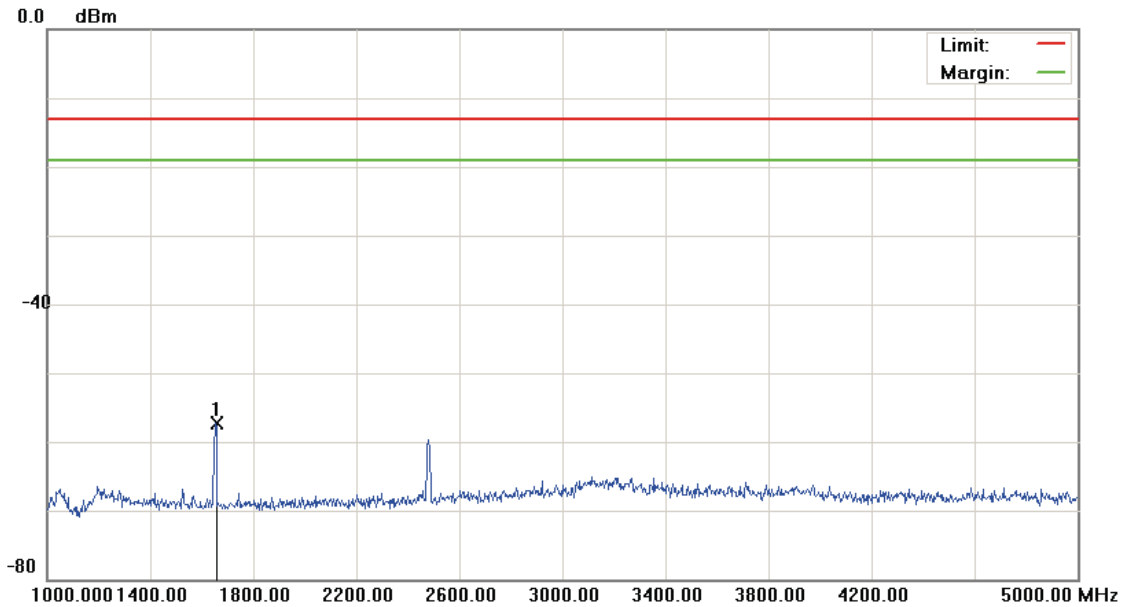

Site: : RF Conducted	Polarization: <i>Conducted po</i>	Temperature: 24.2 °C
Limit: FCC Part 22 conducted(9k-12.75G)	Power: AC 120V/60Hz	Humidity: 54 %
EUT: Smartphone	Distance:	RBW: 1000 KHz VBW: 1000 KHz
M/N: PJ03120		
Mode: WCDMA BAND V		
Note: CH4132		

No.	Mk.	Freq. MHz	Reading Level dBm	Correct Factor dB	Measure- ment dBm	Limit dBm	Over dB	Detector	Antenna Height cm	Table Degree degree	Comment
1	*	1654.000	-61.70	4.45	-57.25	-13.00	-44.25	peak			

\*:Maximum data    x:Over limit    !:over margin

File: PJ03120(CH4132)

Data: #4

Date: 2011/9/9

Time: 下午 05:50:03

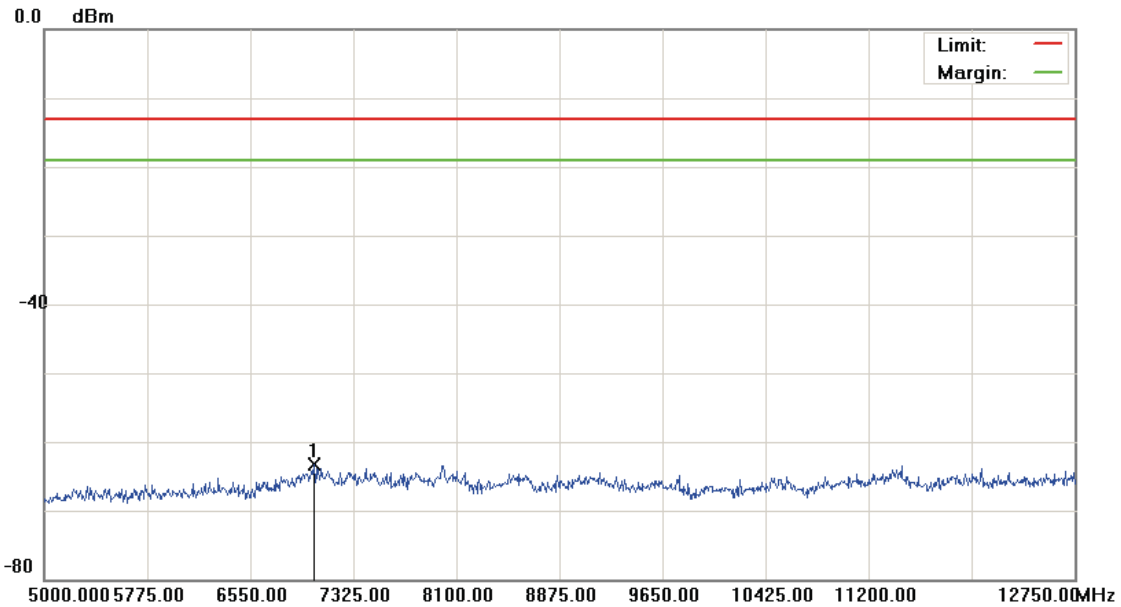

Site: : RF Conducted	Polarization: <i>Conducted po</i>	Temperature: 24.2 °C
Limit: FCC Part 22 conducted(9k-12.75G)	Power: AC 120V/60Hz	Humidity: 54 %
EUT: Smartphone	Distance:	RBW: 1000 KHz VBW: 1000 KHz
M/N: PJ03120		
Mode: WCDMA BAND V		
Note: CH4132		

No.	Mk.	Freq. MHz	Reading Level dBm	Correct Factor dB	Measure- ment dBm	Limit dBm	Over dB	Detector	Antenna Height cm	Table Degree degree	Comment
1	*	7030.500	-68.24	4.85	-63.39	-13.00	-50.39	peak			

\*:Maximum data    x:Over limit    !:over margin

File: PJ03120(CH4183)

Data: #1

Date: 2011/9/9

Time: 下午 05:37:42

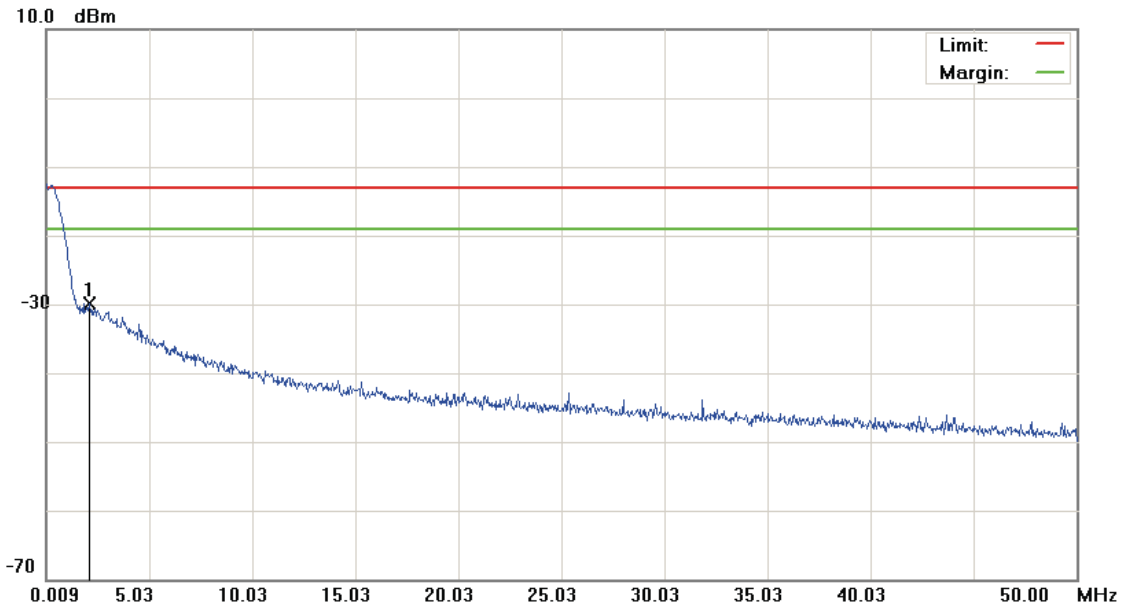

Site: : RF Conducted	Polarization: <i>Conducted po</i>	Temperature: 24.2 °C
Limit: FCC Part 22 conducted(9k-12.75G)	Power: AC 120V/60Hz	Humidity: 54 %
EUT: Smartphone	Distance:	RBW: 1000 KHz VBW: 1000 KHz
M/N: PJ03120		
Mode: WCDMA BAND V		
Note: CH4183		

No.	Mk.	Freq.	Reading Level	Correct Factor	Measurement	Limit	Over	Antenna Height	Table Degree	
		MHz	dBm	dB	dBm	dBm	dB	cm	degree	Comment
1	*	2.1086	-61.37	31.54	-29.83	-13.00	-16.83			peak

\*:Maximum data    x:Over limit    !:over margin

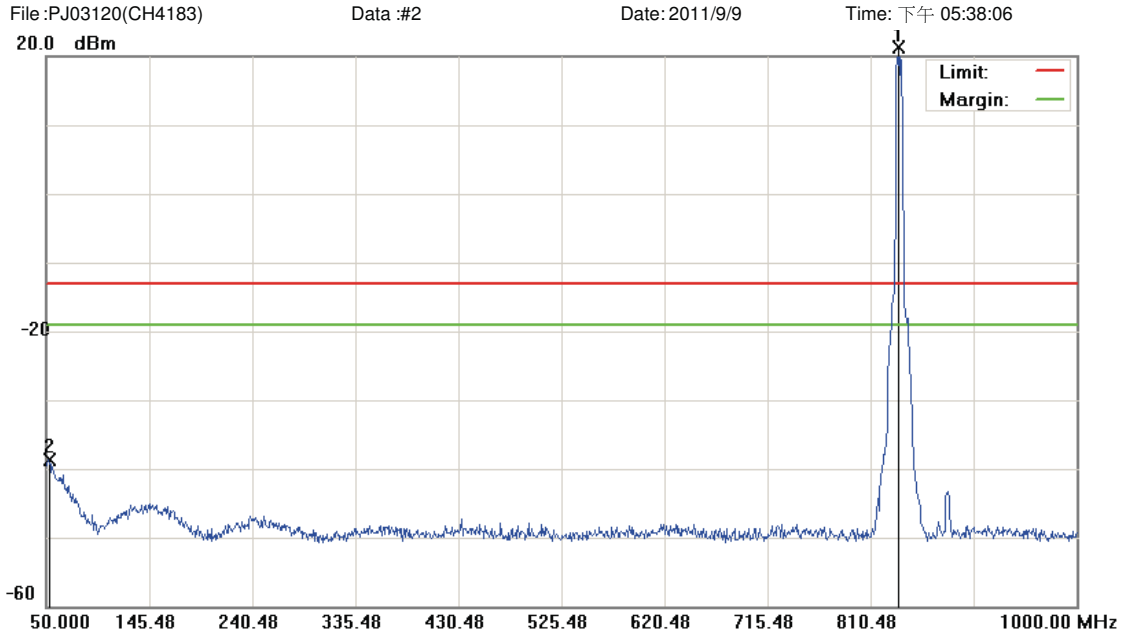

Site: : RF Conducted      Polarization: *Conducted po*      Temperature: 24.2 °C  
 Limit: FCC Part 22 conducted(9k-12.75G)      Power: AC 120V/60Hz      Humidity: 54 %  
 EUT: Smartphone      Distance:      RBW: 1000 KHz VBW: 1000 KHz  
 M/N: PJ03120  
 Mode: WCDMA BAND V  
 Note: CH4183

No.	Mk.	Freq. MHz	Reading Level dBm	Correct Factor dB	Measure- ment dBm	Limit dBm	Over dB	Detector	Antenna Height cm	Table Degree degree	Comment
1	*	835.1750	17.34	3.95	21.29	-13.00	34.29	peak			TX
2		52.3750	-53.00	14.27	-38.73	-13.00	-25.73	peak			

\*:Maximum data    x:Over limit    !:over margin

File: PJ03120(CH4183)

Data: #3

Date: 2011/9/9

Time: 下午 05:40:48

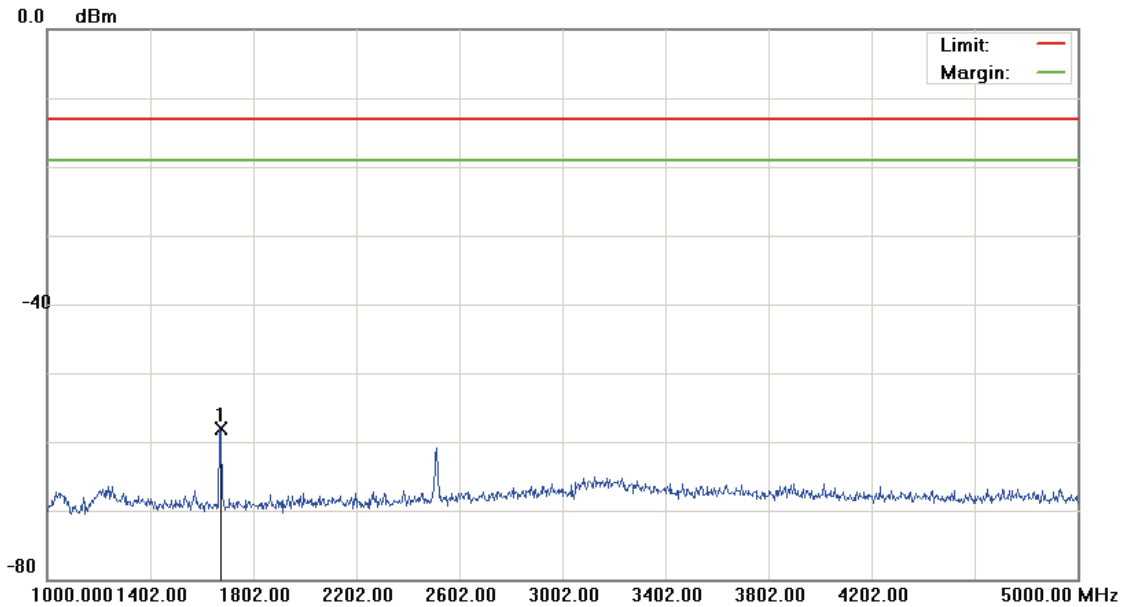

Site: : RF Conducted	Polarization: <i>Conducted po</i>	Temperature: 24.2 °C
Limit: FCC Part 22 conducted(9k-12.75G)	Power: AC 120V/60Hz	Humidity: 54 %
EUT: Smartphone	Distance:	RBW: 1000 KHz VBW: 1000 KHz
M/N: PJ03120		
Mode: WCDMA BAND V		
Note: CH4183		

No.	Mk.	Freq. MHz	Reading Level dBm	Correct Factor dB	Measure- ment dBm	Limit dBm	Over dB	Detector	Antenna Height cm	Table Degree degree	Comment
1	*	1670.000	-62.57	4.46	-58.11	-13.00	-45.11	peak			

\*:Maximum data    x:Over limit    !:over margin

File: PJ03120(CH4183)

Data :#4

Date: 2011/9/9

Time: 下午 05:41:12

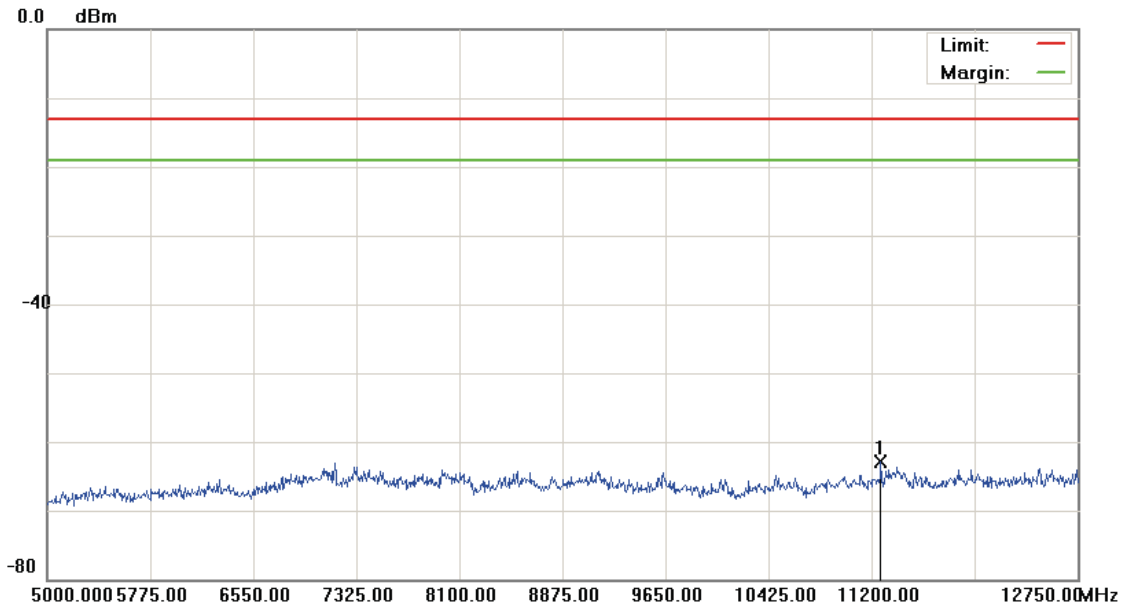

Site: : RF Conducted

 Polarization: *Conducted po*

Temperature: 24.2 °C

Limit: FCC Part 22 conducted(9k-12.75G)

Power: AC 120V/60Hz

Humidity: 54 %

EUT: Smartphone

Distance:

RBW: 1000 KHz VBW: 1000 KHz

M/N: PJ03120

Mode: WCDMA BAND V

Note: CH4183

No.	Mk.	Freq.	Reading Level	Correct Factor	Measurement	Limit	Over	Antenna Height	Table Degree	Detector	Comment
		MHz	dBm	dB	dBm	dBm	dB	cm	degree		
1	*	11269.750	-67.99	5.05	-62.94	-13.00	-49.94			peak	

\*:Maximum data    x:Over limit    !:over margin

File: PJ03120(CH4233)

Data: #1

Date: 2011/9/9

Time: 下午 05:45:03

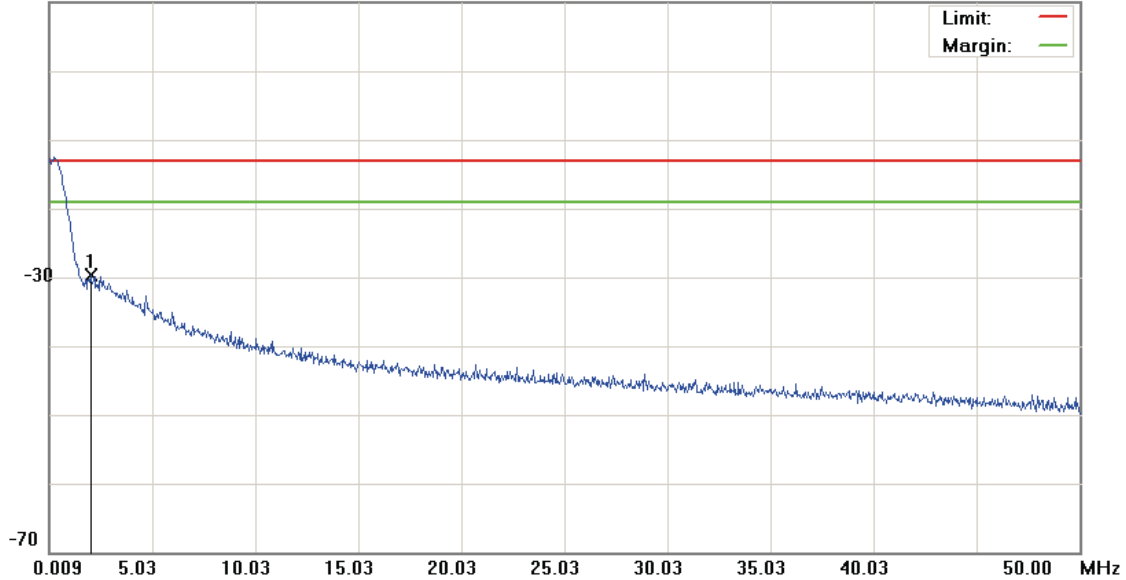
**10.0 dBm**

Site: : RF Conducted	Polarization: <i>Conducted po</i>	Temperature: 24.2 °C
Limit: FCC Part 22 conducted(9k-12.75G)	Power: AC 120V/60Hz	Humidity: 54 %
EUT: Smartphone	Distance:	RBW: 1000 KHz VBW: 1000 KHz
M/N: PJ03120		
Mode: WCDMA BAND V		
Note: CH4233		

No.	Mk.	Freq. MHz	Reading Level dBm	Correct Factor dB	Measure- ment dBm	Limit dBm	Over dB	Antenna Height cm	Table Degree degree	Comment
1	*	2.0335	-61.16	31.41	-29.75	-13.00	-16.75	peak		

\*:Maximum data    x:Over limit    !:over margin



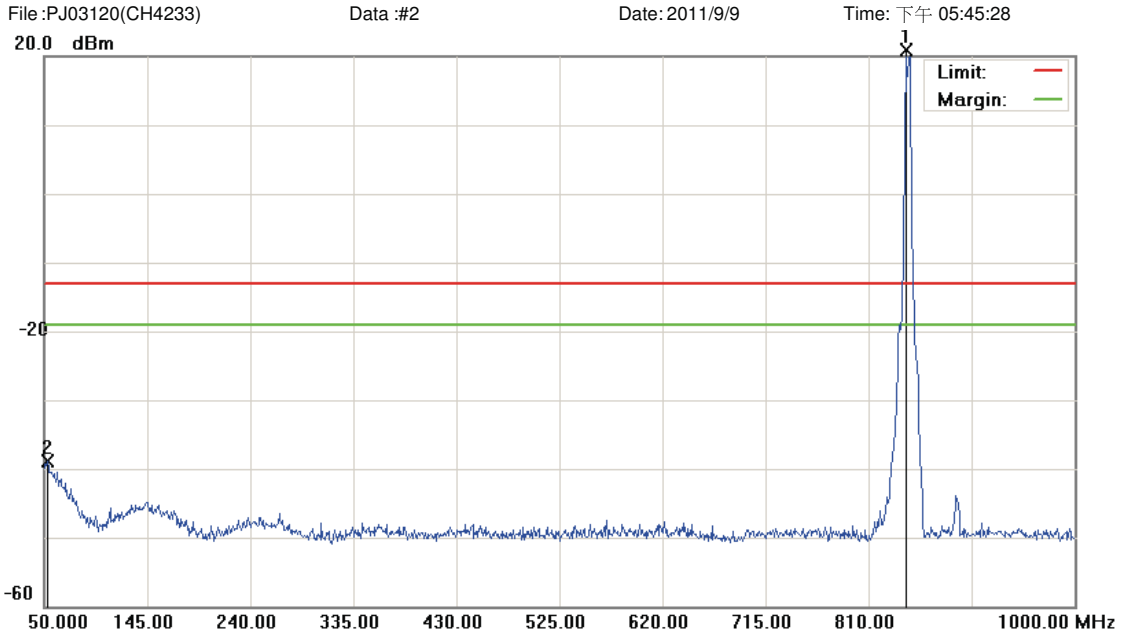

Site: : RF Conducted	Polarization: <i>Conducted po</i>	Temperature: 24.2 °C
Limit: FCC Part 22 conducted(9k-12.75G)	Power: AC 120V/60Hz	Humidity: 54 %
EUT: Smartphone	Distance:	RBW: 1000 KHz VBW: 1000 KHz
M/N: PJ03120		
Mode: WCDMA BAND V		
Note: CH4233		

No.	Mk.	Freq. MHz	Reading Level dBm	Correct Factor dB	Measure- ment dBm	Limit dBm	Over dB	Detector	Antenna Height cm	Table Degree degree	Comment
1	*	845.1500	17.01	3.99	21.00	-13.00	34.00	peak			
2		52.8500	-53.18	14.19	-38.99	-13.00	-25.99	peak			Tx

\*:Maximum data    x:Over limit    !:over margin

File: PJ03120(CH4233)

Data :#3

Date: 2011/9/9

Time: 下午 05:48:17

20.0 dBm

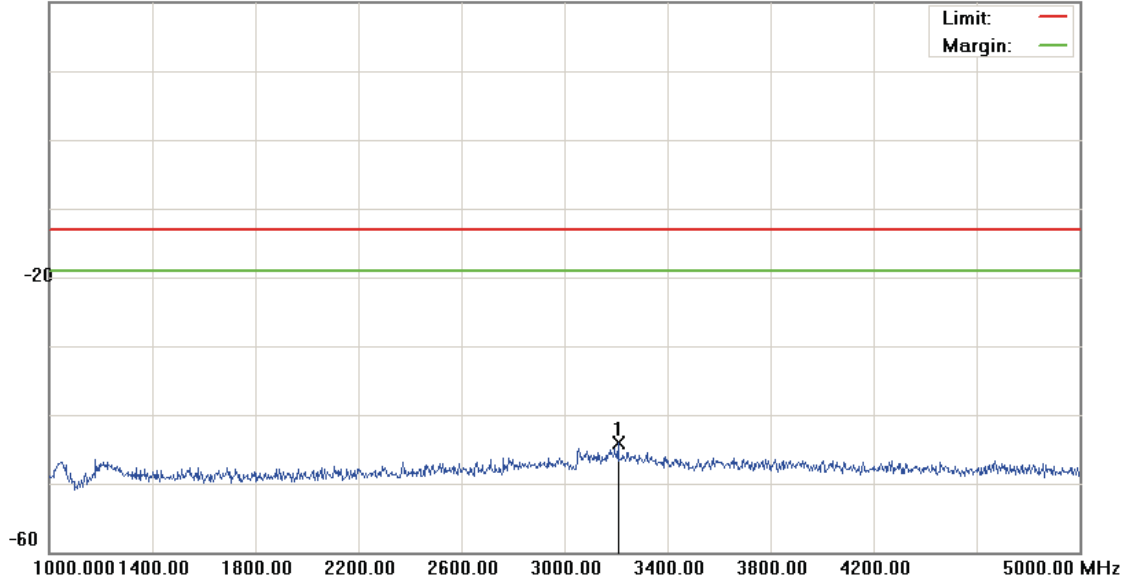

Site: : RF Conducted	Polarization: <i>Conducted po</i>	Temperature: 24.2 °C
Limit: FCC Part 22 conducted(9k-12.75G)	Power: AC 120V/60Hz	Humidity: 54 %
EUT: Smartphone	Distance:	RBW: 1000 KHz VBW: 1000 KHz
M/N: PJ03120		
Mode: WCDMA BAND V		
Note: CH4233		

No.	Mk.	Freq. MHz	Reading Level dBm	Correct Factor dB	Measure- ment dBm	Limit dBm	Over dB	Detector	Antenna Height cm	Table Degree degree	Comment
1	*	3210.000	-48.74	4.67	-44.07	-13.00	-31.07	peak			

\*:Maximum data    x:Over limit    !:over margin

File: PJ03120(CH4233)

Data :#4

Date: 2011/9/9

Time: 下午 05:48:41

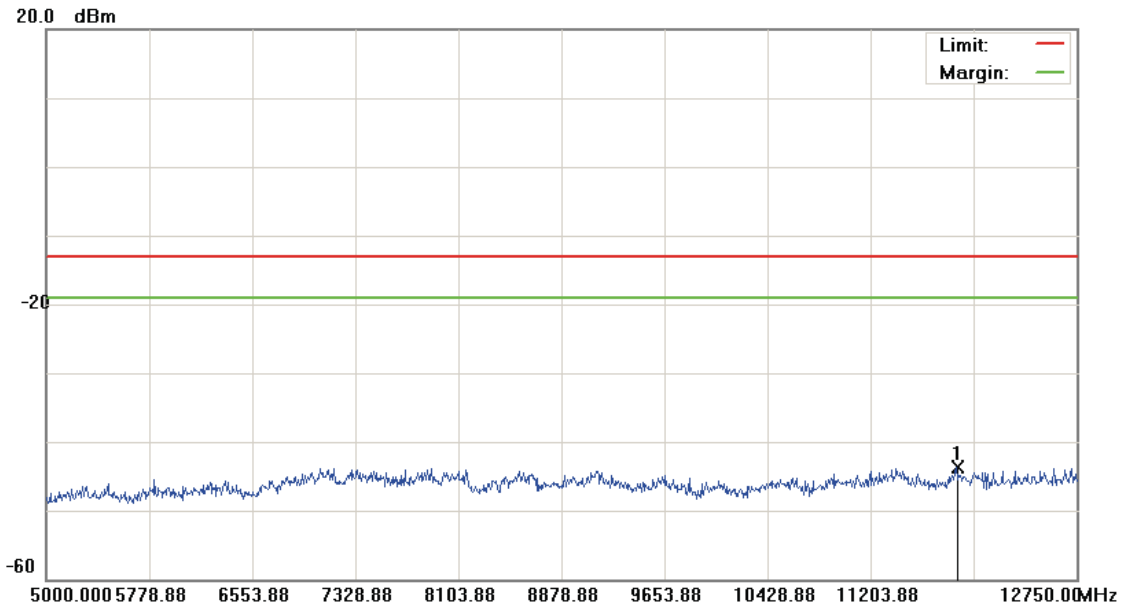

Site: : RF Conducted

 Polarization: *Conducted po*

Temperature: 24.2 °C

Limit: FCC Part 22 conducted(9k-12.75G)

Power: AC 120V/60Hz

Humidity: 54 %

EUT: Smartphone

Distance:

RBW: 1000 KHz VBW: 1000 KHz

M/N: PJ03120

Mode: WCDMA BAND V

Note: CH4233

No.	Mk.	Freq.	Reading Level	Correct Factor	Measurement	Limit	Over	Antenna Height	Table Degree	Detector	Comment
		MHz	dBm	dB	dBm	dBm	dB	cm	degree		
1	*	11847.125	-49.41	5.71	-43.70	-13.00	-30.70			peak	

\*:Maximum data    x:Over limit    !:over margin

## 6 Field Strength of Spurious Radiation Test

### 6.1. Limit

The power of any emission outside of the authorized operating frequency ranges must be attenuated below the transmitting power (P) by a factor of at least  $43 + 10\log(P)$  dB.

It is measured by means of a calibrated spectrum analyzer and scanned from 30 MHz up to a frequency including its 10<sup>th</sup> harmonic.

### 6.2. Test Instruments

3 Meter Chamber					
Equipment	Manufacturer	Model Number	Serial Number	Cal. Date	Remark
RF Pre-selector	Agilent	N9039A	MY46520256	01/18/2011	(2)
Spectrum Analyzer	Agilent	E4446A	MY46180578	01/18/2011	(1)
Pre Amplifier	Agilent	8449B	3008A02237	02/23/2011	(1)
Pre Amplifier	Agilent	8447D	2944A10961	02/23/2011	(1)
Broadband Antenna (30MHz~1GHz)	SCHWARZBECK MESS-ELEKTRONIK	VULB9163	9163-270	07/29/2011	(1)
Horn Antenna (1~18GHz)	SCHWARZBECK MESS-ELEKTRONIK	BBHA9120D	9120D-550	06/29/2011	(1)
Horn Antenna (18~40GHz)	SCHWARZBECK MESS-ELEKTRONIK	BBHA9170	9170-320	06/28/2011	(1)
Test Site	ATL	TE01	888001	12/24/2010	(1)

Remark: <sup>(1)</sup> Calibration period 1 year. <sup>(2)</sup> Calibration period 2 years.

NOTE: N.C.R. = No Calibration Request.

### 6.3. Setup

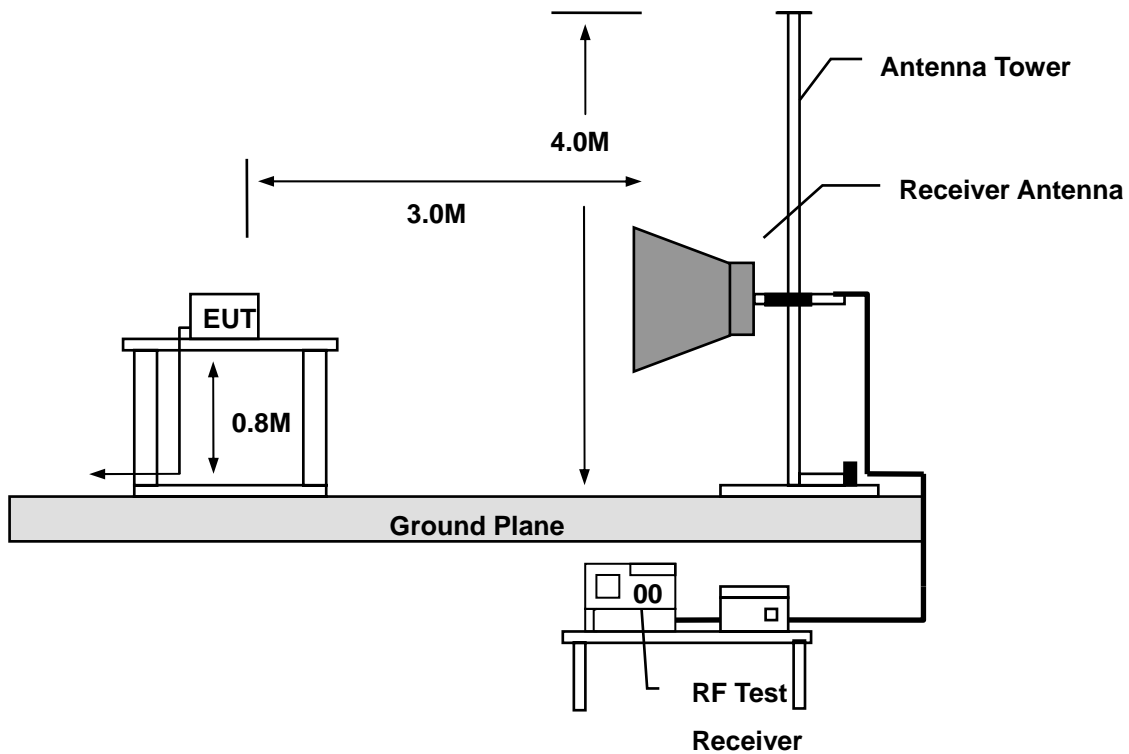

### 6.4. Test Procedure

Final radiation measurements were made on a three-meter, Semi Anechoic Chamber. The EUT system was placed on a nonconductive turntable which is 0.8 meters height, top surface 1.0 x 1.5 meter. The spectrum was examined from 250 MHz to 2.5 GHz in order to cover the whole spectrum below 10th harmonic which could generate from the EUT. During the test, EUT was set to transmit continuously & Measurements spectrum range from 30 MHz to 26.5 GHz is investigated.

For measurements below 1 GHz the resolution bandwidth is set to 100 kHz for peak detection measurements or 120 kHz for quasi-peak detection measurements. Peak detection is used unless otherwise noted as quasi-peak.

For measurements above 1 GHz the resolution bandwidth is set to 1 MHz, and then the video bandwidth is set to 1 MHz for peak measurements and 10 Hz for average measurements.

A nonconductive material surrounded the EUT to supporting the EUT for standing on three orthogonal planes. At each condition, the EUT was rotated 360 degrees, and the antenna was raised and lowered from one to four meters to find the maximum emission levels. Measurements were taken using both horizontal and vertical antenna polarization.

SCHWARZBECK MESS-ELEKTRONIK Biconilog Antenna (model VULB9163) at 3 Meter and the SCHWARZBECK Double Ridged Guide Antenna (model BBHA9120D&9170) was used in frequencies 1 – 26.5 GHz at a distance of 1 meter. All test results were extrapolated to equivalent signal at 3 meters utilizing an inverse linear distance extrapolation Factor (20dB/decade).

For testing above 1GHz, the emission level of the EUT in peak mode was 20dB lower than average limit (that means the emission level in peak mode also complies with the limit in average mode), then testing will be stopped and peak values of EUT will be reported, otherwise, the emissions will be measured in average mode again and reported.

Appropriate preamplifiers were used for improving sensitivity and precautions were taken to avoid overloading or desensitizing the spectrum analyzer. No post – detector video filters were used in the test.

The spectrum analyzer's 6 dB bandwidth was set to 1 MHz, and the analyzer was operated in the peak detection mode, for frequencies both below and up 1 GHz. The average levels were obtained by subtracting the duty cycle correction factor from the peak readings.

The following procedures were used to convert the emission levels measured in decibels referenced to 1 microvolt (dBuV) into field intensity in micro volts per meter (uV/m).

The actual field intensity in decibels referenced to 1 microvolt in to field intensity in micro volts per meter (dBuV/m).

The actual field intensity in decibels referenced to 1 microvolt per meter (dBuV/m) is determined by algebraically adding the measured reading in dBuV, the antenna factor (dB), and cable loss (dB) and Subtracting the gain of preamplifier (dB) is auto calculate in spectrum analyzer.

$$(1) \text{ Amplitude (dBuV/m) = FI (dBuV) +AF (dBuV) +CL (dBuV)-Gain (dB)}$$

FI= Reading of the field intensity.

AF= Antenna factor.

CL= Cable loss.

P.S Amplitude is auto calculate in spectrum analyzer.

$$(2) \text{ Actual Amplitude (dBuV/m) = Amplitude (dBuV)-Dis(dB)}$$

The FCC specified emission limits were calculated according the EUT operating frequency and by following linear interpolation equations:

(a) For fundamental frequency : Transmitter Output < +30dBm

(b) For spurious frequency : Spurious emission limits = fundamental emission limit /10

## 6.5. Uncertainty

The measurement uncertainty is defined as for Field Strength of Spurious Radiation measurement is  $\pm 3.072$  dB.

## 6.6. Test Result

Standard:	FCC Part 22	Test Distance:	3m
Test item:	Radiated Emission	Power:	AC 120V/60Hz
Model:	PJ03120	Temp.(°C)/Hum.(%RH):	26(°C)/60%RH
Mode:	Mode 1	Date:	10/07/2011
Frequency:	824.2 MHz	Test By:	Gary Wu

No.	Frequency (MHz)	Reading (dBm)	Correct Factor(dB)	Result (dBm)	Limit (dBm)	Margin (dB)	Remark	Ant.Polar. H / V
1	210.5000	-80.16	0.58	-79.58	-13.00	-66.58	peak	H
2	334.0000	-80.45	-0.67	-81.12	-13.00	-68.12	peak	H
3	544.0000	-80.98	8.17	-72.81	-13.00	-59.81	peak	H
4	726.5000	-81.55	7.72	-73.83	-13.00	-60.83	peak	H
5	771.5000	-81.99	9.72	-72.27	-13.00	-59.27	peak	H
6	942.0000	-81.61	14.86	-66.75	-13.00	-53.75	peak	H
7	4852.000	-72.22	19.20	-53.02	-13.00	-40.02	peak	H
8	6700.000	-72.79	26.72	-46.07	-13.00	-33.07	peak	H
9	7804.000	-70.30	29.44	-40.86	-13.00	-27.86	peak	H
1	201.5000	-77.41	9.97	-67.44	-13.00	-54.44	peak	V
2	345.5000	-79.90	1.53	-78.37	-13.00	-65.37	peak	V
3	555.0000	-79.32	4.34	-74.98	-13.00	-61.98	peak	V
4	679.5000	-77.24	9.55	-67.69	-13.00	-54.69	peak	V
5	731.5000	-72.77	10.65	-62.12	-13.00	-49.12	peak	V
6	936.0000	-82.21	12.57	-69.64	-13.00	-56.64	peak	V
7	3148.000	-69.10	17.33	-51.77	-13.00	-38.77	peak	V
8	8080.000	-72.16	26.31	-45.85	-13.00	-32.85	peak	V
9	10636.000	-72.96	34.17	-38.79	-13.00	-25.79	peak	V

Standard:	FCC Part 22	Test Distance:	3m
Test item:	Radiated Emission	Power:	AC 120V/60Hz
Model:	PJ03120	Temp.(°C)/Hum.(%RH):	26(°C)/60%RH
Mode:	Mode 1	Date:	10/07/2011
Frequency:	836.4 MHz	Test By:	Gary Wu

No.	Frequency (MHz)	Reading (dBm)	Correct Factor(dB)	Result (dBm)	Limit (dBm)	Margin (dB)	Remark	Ant.Polar. H / V
1	54.0000	-73.91	6.59	-67.32	-13.00	-54.32	peak	H
2	198.0000	-74.49	1.11	-73.38	-13.00	-60.38	peak	H
3	301.5000	-81.80	-2.25	-84.05	-13.00	-71.05	peak	H
4	488.0000	-80.40	6.23	-74.17	-13.00	-61.17	peak	H
5	597.5000	-80.09	7.90	-72.19	-13.00	-59.19	peak	H
6	674.5000	-80.11	7.06	-73.05	-13.00	-60.05	peak	H
7	3616.000	-68.60	15.72	-52.88	-13.00	-39.88	peak	H
8	5680.000	-71.97	22.18	-49.79	-13.00	-36.79	peak	H
9	7300.000	-71.89	28.55	-43.34	-13.00	-30.34	peak	H
1	267.0000	-80.86	-4.34	-85.20	-13.00	-72.20	peak	V
2	465.5000	-80.28	4.93	-75.35	-13.00	-62.35	peak	V
3	548.5000	-80.65	8.07	-72.58	-13.00	-59.58	peak	V
4	687.5000	-79.80	6.99	-72.81	-13.00	-59.81	peak	V
5	776.5000	-80.66	9.99	-70.67	-13.00	-57.67	peak	V
6	972.0000	-81.51	14.53	-66.98	-13.00	-53.98	peak	V
7	4960.000	-71.60	19.85	-51.75	-13.00	-38.75	peak	V
8	7516.000	-71.92	29.22	-42.70	-13.00	-29.70	peak	V
9	9580.000	-71.82	30.55	-41.27	-13.00	-28.27	peak	H



Standard:	FCC Part 22	Test Distance:	3m
Test item:	Radiated Emission	Power:	AC 120V/60Hz
Model:	PJ03120	Temp.(°C)/Hum.(%RH):	26(°C)/60%RH
Mode:	Mode 1	Date:	10/07/2011
Frequency:	848.8 MHz	Test By:	Gary Wu

No.	Frequency (MHz)	Reading (dBm)	Correct Factor(dB)	Result (dBm)	Limit (dBm)	Margin (dB)	Remark	Ant.Polar. H / V
1	60.5000	-66.02	-5.27	-71.29	-13.00	-58.29	peak	H
2	93.0000	-63.24	-4.61	-67.85	-13.00	-54.85	peak	H
3	138.0000	-69.76	10.02	-59.74	-13.00	-46.74	peak	H
4	338.0000	-79.06	1.17	-77.89	-13.00	-64.89	peak	H
5	538.0000	-79.41	4.14	-75.27	-13.00	-62.27	peak	H
6	744.0000	-75.52	10.59	-64.93	-13.00	-51.93	peak	H
7	2176.000	-67.37	10.51	-56.86	-13.00	-43.86	peak	H
8	6628.000	-71.75	25.05	-46.70	-13.00	-33.70	peak	H
9	10996.000	-73.04	36.66	-36.38	-13.00	-23.38	peak	H
1	62.0000	-65.51	-5.78	-71.29	-13.00	-58.29	peak	V
2	128.5000	-75.16	12.88	-62.28	-13.00	-49.28	peak	V
3	231.0000	-80.38	2.02	-78.36	-13.00	-65.36	peak	V
4	541.5000	-80.97	4.28	-76.69	-13.00	-63.69	peak	V
5	660.5000	-80.01	9.40	-70.61	-13.00	-57.61	peak	V
6	770.5000	-80.03	11.13	-68.90	-13.00	-55.90	peak	V
7	4924.000	-71.38	23.25	-48.13	-13.00	-35.13	peak	V
8	6208.000	-72.59	23.65	-48.94	-13.00	-35.94	peak	V
9	8956.000	-73.06	24.34	-48.72	-13.00	-35.72	peak	V

Standard:	FCC Part 24	Test Distance:	3m
Test item:	Radiated Emission	Power:	AC 120V/60Hz
Model:	PJ03120	Temp.(°C)/Hum.(%RH):	26(°C)/60%RH
Mode:	Mode 2	Date:	10/07/2011
Frequency:	1850.2 MHz	Test By:	Gary Wu

No.	Frequency (MHz)	Reading (dBm)	Correct Factor(dB)	Result (dBm)	Limit (dBm)	Margin (dB)	Remark	Ant.Polar. H / V
1	55.0000	-74.53	6.28	-68.25	-13.00	-55.25	peak	H
2	101.0000	-81.53	-2.10	-83.63	-13.00	-70.63	peak	H
3	197.5000	-74.57	0.65	-73.92	-13.00	-60.92	peak	H
4	460.0000	-80.53	4.62	-75.91	-13.00	-62.91	peak	H
5	648.0000	-79.92	6.95	-72.97	-13.00	-59.97	peak	H
6	832.0000	-80.43	12.03	-68.40	-13.00	-55.40	peak	H
7	3220.000	-67.53	14.62	-52.91	-13.00	-39.91	peak	H
8	5104.000	-69.72	20.43	-49.29	-13.00	-36.29	peak	H
9	10468.000	-72.11	33.97	-38.14	-13.00	-25.14	peak	H
1	229.0000	-80.73	2.51	-78.22	-13.00	-65.22	peak	V
2	350.0000	-80.10	1.81	-78.29	-13.00	-65.29	peak	V
3	471.0000	-81.37	2.10	-79.27	-13.00	-66.27	peak	V
4	624.5000	-80.96	8.83	-72.13	-13.00	-59.13	peak	V
5	796.5000	-80.62	11.77	-68.85	-13.00	-55.85	peak	V
6	879.5000	-81.74	10.91	-70.83	-13.00	-57.83	peak	V
7	4180.000	-69.51	21.16	-48.35	-13.00	-35.35	peak	V
8	6556.000	-72.74	24.96	-47.78	-13.00	-34.78	peak	V
9	9712.000	-70.91	29.35	-41.56	-13.00	-28.56	peak	V

Standard:	FCC Part 24	Test Distance:	3m
Test item:	Radiated Emission	Power:	AC 120V/60Hz
Model:	PJ03120	Temp.(°C)/Hum.(%RH):	26(°C)/60%RH
Mode:	Mode 2	Date:	10/07/2011
Frequency:	1880.0 MHz	Test By:	Gary Wu

No.	Frequency (MHz)	Reading (dBm)	Correct Factor(dB)	Result (dBm)	Limit (dBm)	Margin (dB)	Remark	Ant.Polar. H / V
1	55.0000	-74.53	6.28	-68.25	-13.00	-55.25	peak	H
2	92.5000	-68.10	-0.43	-68.53	-13.00	-55.53	peak	H
3	120.5000	-79.24	-5.39	-84.63	-13.00	-71.63	peak	H
4	145.5000	-65.13	-3.10	-68.23	-13.00	-55.23	peak	H
5	160.0000	-69.47	1.45	-68.02	-13.00	-55.02	peak	H
6	366.0000	-82.18	0.26	-81.92	-13.00	-68.92	peak	H
7	5152.000	-71.36	20.58	-50.78	-13.00	-37.78	peak	H
8	7324.000	-71.20	28.62	-42.58	-13.00	-29.58	peak	H
9	8836.000	-72.27	27.03	-45.24	-13.00	-32.24	peak	H
1	294.0000	-81.90	2.17	-79.73	-13.00	-66.73	peak	V
2	373.5000	-81.99	1.88	-80.11	-13.00	-67.11	peak	V
3	471.0000	-81.37	2.10	-79.27	-13.00	-66.27	peak	V
4	738.5000	-79.77	10.52	-69.25	-13.00	-56.25	peak	V
5	867.0000	-82.25	11.36	-70.89	-13.00	-57.89	peak	V
6	977.5000	-82.28	12.50	-69.78	-13.00	-56.78	peak	V
7	6652.000	-70.37	25.07	-45.30	-13.00	-32.30	peak	V
8	9100.000	-71.21	25.05	-46.16	-13.00	-33.16	peak	V
9	11632.000	-72.20	38.30	-33.90	-13.00	-20.90	peak	V

Standard:	FCC Part 24	Test Distance:	3m
Test item:	Radiated Emission	Power:	AC 120V/60Hz
Model:	PJ03120	Temp.(°C)/Hum.(%RH):	26(°C)/60%RH
Mode:	Mode 2	Date:	10/07/2011
Frequency:	1909.8 MHz	Test By:	Gary Wu

No.	Frequency (MHz)	Reading (dBm)	Correct Factor(dB)	Result (dBm)	Limit (dBm)	Margin (dB)	Remark	Ant.Polar. H / V
1	30.0000	-72.16	8.01	-64.15	-13.00	-51.15	peak	H
2	55.0000	-74.53	6.28	-68.25	-13.00	-55.25	peak	H
3	127.5000	-78.43	-4.94	-83.37	-13.00	-70.37	peak	H
4	151.5000	-62.59	-1.26	-63.85	-13.00	-50.85	peak	H
5	247.0000	-81.11	-3.57	-84.68	-13.00	-71.68	peak	H
6	584.0000	-79.69	7.68	-72.01	-13.00	-59.01	peak	H
7	3328.000	-67.63	14.95	-52.68	-13.00	-39.68	peak	H
8	7048.000	-70.57	27.74	-42.83	-13.00	-29.83	peak	H
9	10864.000	-73.40	35.79	-37.61	-13.00	-24.61	peak	H
1	157.5000	-74.04	11.49	-62.55	-13.00	-49.55	peak	V
2	275.5000	-80.84	0.36	-80.48	-13.00	-67.48	peak	V
3	350.0000	-80.10	1.81	-78.29	-13.00	-65.29	peak	V
4	445.0000	-80.85	1.53	-79.32	-13.00	-66.32	peak	V
5	796.5000	-80.62	11.77	-68.85	-13.00	-55.85	peak	V
6	957.5000	-81.89	12.42	-69.47	-13.00	-56.47	peak	V
7	4072.000	-68.96	20.82	-48.14	-13.00	-35.14	peak	V
8	6520.000	-70.44	24.93	-45.51	-13.00	-32.51	peak	V
9	11548.000	-72.48	38.17	-34.31	-13.00	-21.31	peak	V

Standard:	FCC Part 24	Test Distance:	3m
Test item:	Radiated Emission	Power:	AC 120V/60Hz
Model:	PJ03120	Temp.(°C)/Hum.(%RH):	26(°C)/60%RH
Mode:	Mode 3	Date:	10/06/2011
Frequency:	1852.4 MHz	Test By:	Gary Wu

No.	Frequency (MHz)	Reading (dBm)	Correct Factor(dB)	Result (dBm)	Limit (dBm)	Margin (dB)	Remark	Ant.Polar. H / V
1	350.0000	-80.77	-0.26	-81.03	-13.00	-68.03	peak	H
2	514.0000	-79.88	7.46	-72.42	-13.00	-59.42	peak	H
3	710.5000	-80.82	7.23	-73.59	-13.00	-60.59	peak	H
4	738.0000	-81.60	8.13	-73.47	-13.00	-60.47	peak	H
5	862.0000	-81.21	13.05	-68.16	-13.00	-55.16	peak	H
6	920.0000	-82.09	14.74	-67.35	-13.00	-54.35	peak	H
7	2596.000	-68.21	12.52	-55.69	-13.00	-42.69	peak	H
8	5632.000	-74.04	22.05	-51.99	-13.00	-38.99	peak	H
9	9820.000	-73.10	31.61	-41.49	-13.00	-28.49	peak	H
1	63.5000	-65.30	-6.31	-71.61	-13.00	-58.61	peak	V
2	148.0000	-68.40	8.09	-60.31	-13.00	-47.31	peak	V
3	275.5000	-80.84	0.36	-80.48	-13.00	-67.48	peak	V
4	507.5000	-81.13	2.88	-78.25	-13.00	-65.25	peak	V
5	712.5000	-81.01	10.61	-70.40	-13.00	-57.40	peak	V
6	879.5000	-81.74	10.91	-70.83	-13.00	-57.83	peak	V
7	2812.000	-71.57	14.89	-56.68	-13.00	-43.68	peak	V
8	8500.000	-75.26	26.08	-49.18	-13.00	-36.18	peak	V
9	10048.000	-73.72	30.78	-42.94	-13.00	-29.94	peak	V

Standard:	FCC Part 24	Test Distance:	3m
Test item:	Radiated Emission	Power:	AC 120V/60Hz
Model:	PJ03120	Temp.(°C)/Hum.(%RH):	26(°C)/60%RH
Mode:	Mode 3	Date:	10/06/2011
Frequency:	1880.0 MHz	Test By:	Gary Wu

No.	Frequency (MHz)	Reading (dBm)	Correct Factor(dB)	Result (dBm)	Limit (dBm)	Margin (dB)	Remark	Ant.Polar. H / V
1	55.0000	-74.53	6.28	-68.25	-13.00	-55.25	peak	H
2	103.0000	-82.15	-2.71	-84.86	-13.00	-71.86	peak	H
3	185.0000	-68.76	-6.54	-75.30	-13.00	-62.30	peak	H
4	240.0000	-81.19	-2.09	-83.28	-13.00	-70.28	peak	H
5	539.5000	-81.30	8.25	-73.05	-13.00	-60.05	peak	H
6	849.5000	-82.57	12.53	-70.04	-13.00	-57.04	peak	H
7	6736.000	-74.03	26.82	-47.21	-13.00	-34.21	peak	H
8	7924.000	-74.60	29.55	-45.05	-13.00	-32.05	peak	H
9	9580.000	-74.91	30.55	-44.36	-13.00	-31.36	peak	H
1	122.0000	-78.86	6.42	-72.44	-13.00	-59.44	peak	V
2	157.5000	-74.04	11.49	-62.55	-13.00	-49.55	peak	V
3	275.5000	-80.84	0.36	-80.48	-13.00	-67.48	peak	V
4	471.0000	-81.37	2.10	-79.27	-13.00	-66.27	peak	V
5	712.5000	-81.01	10.61	-70.40	-13.00	-57.40	peak	V
6	879.5000	-81.74	10.91	-70.83	-13.00	-57.83	peak	V
7	1552.000	-68.41	5.96	-62.45	-13.00	-49.45	peak	V
8	5536.000	-73.90	23.44	-50.46	-13.00	-37.46	peak	V
9	10348.000	-74.35	32.41	-41.94	-13.00	-28.94	peak	V

Standard:	FCC Part 24	Test Distance:	3m
Test item:	Radiated Emission	Power:	AC 120V/60Hz
Model:	PJ03120	Temp.(°C)/Hum.(%RH):	26(°C)/60%RH
Mode:	Mode 3	Date:	10/06/2011
Frequency:	1907.6 MHz	Test By:	Gary Wu

No.	Frequency (MHz)	Reading (dBm)	Correct Factor(dB)	Result (dBm)	Limit (dBm)	Margin (dB)	Remark	Ant.Polar. H / V
1	233.0000	-81.77	-1.27	-83.04	-13.00	-70.04	peak	H
2	308.5000	-82.76	-1.75	-84.51	-13.00	-71.51	peak	H
3	410.5000	-82.14	3.02	-79.12	-13.00	-66.12	peak	H
4	605.0000	-82.03	7.88	-74.15	-13.00	-61.15	peak	H
5	731.0000	-81.99	7.88	-74.11	-13.00	-61.11	peak	H
6	889.5000	-82.86	13.62	-69.24	-13.00	-56.24	peak	H
7	3280.000	-70.50	14.80	-55.70	-13.00	-42.70	peak	H
8	6220.000	-74.58	24.41	-50.17	-13.00	-37.17	peak	H
9	9088.000	-72.34	26.88	-45.46	-13.00	-32.46	peak	H
1	54.5000	-65.80	-5.83	-71.63	-13.00	-58.63	peak	V
2	123.0000	-77.18	7.42	-69.76	-13.00	-56.76	peak	V
3	189.0000	-75.97	0.89	-75.08	-13.00	-62.08	peak	V
4	255.5000	-82.42	-1.27	-83.69	-13.00	-70.69	peak	V
5	405.5000	-82.24	1.32	-80.92	-13.00	-67.92	peak	V
6	563.0000	-81.59	4.59	-77.00	-13.00	-64.00	peak	V
7	5116.000	-71.84	23.45	-48.39	-13.00	-35.39	peak	V
8	6940.000	-72.29	25.43	-46.86	-13.00	-33.86	peak	V
9	9076.000	-73.35	24.84	-48.51	-13.00	-35.51	peak	V

Standard:	FCC Part 22	Test Distance:	3m
Test item:	Radiated Emission	Power:	AC 120V/60Hz
Model:	PJ03120	Temp.(°C)/Hum.(%RH):	26(°C)/60%RH
Mode:	Mode 4	Date:	10/06/2011
Frequency:	826.4 MHz	Test By:	Gary Wu

No.	Frequency (MHz)	Reading (dBm)	Correct Factor(dB)	Result (dBm)	Limit (dBm)	Margin (dB)	Remark	Ant.Polar. H / V
1	37.0000	-76.25	8.74	-67.51	-13.00	-54.51	peak	H
2	54.5000	-74.18	6.44	-67.74	-13.00	-54.74	peak	H
3	92.5000	-68.14	-0.43	-68.57	-13.00	-55.57	peak	H
4	153.0000	-62.60	-0.77	-63.37	-13.00	-50.37	peak	H
5	351.0000	-81.54	-0.23	-81.77	-13.00	-68.77	peak	H
6	695.5000	-80.85	6.96	-73.89	-13.00	-60.89	peak	H
7	2716.000	-70.02	12.94	-57.08	-13.00	-44.08	peak	H
8	6052.000	-72.10	23.37	-48.73	-13.00	-35.73	peak	H
9	8068.000	-71.88	29.49	-42.39	-13.00	-29.39	peak	H
1	92.5000	-64.22	-4.73	-68.95	-13.00	-55.95	peak	H
2	134.5000	-71.47	11.93	-59.54	-13.00	-46.54	peak	H
3	152.5000	-70.90	9.08	-61.82	-13.00	-48.82	peak	H
4	211.5000	-83.11	8.40	-74.71	-13.00	-61.71	peak	H
5	336.0000	-81.16	1.16	-80.00	-13.00	-67.00	peak	H
6	572.5000	-81.59	5.34	-76.25	-13.00	-63.25	peak	H
7	2548.000	-69.28	12.73	-56.55	-13.00	-43.55	peak	H
8	9424.000	-71.78	27.84	-43.94	-13.00	-30.94	peak	V
9	12004.000	-73.20	38.96	-34.24	-13.00	-21.24	peak	H



Standard:	FCC Part 22	Test Distance:	3m
Test item:	Radiated Emission	Power:	AC 120V/60Hz
Model:	PJ03120	Temp.(°C)/Hum.(%RH):	26(°C)/60%RH
Mode:	Mode 4	Date:	10/06/2011
Frequency:	836.4 MHz	Test By:	Gary Wu

No.	Frequency (MHz)	Reading (dBm)	Correct Factor(dB)	Result (dBm)	Limit (dBm)	Margin (dB)	Remark	Ant.Polar. H / V
1	36.5000	-71.83	8.59	-63.24	-13.00	-50.24	peak	H
2	92.5000	-68.21	-0.43	-68.64	-13.00	-55.64	peak	H
3	153.5000	-63.54	-0.62	-64.16	-13.00	-51.16	peak	H
4	197.0000	-72.44	0.18	-72.26	-13.00	-59.26	peak	H
5	489.0000	-80.11	6.28	-73.83	-13.00	-60.83	peak	H
6	780.0000	-80.99	10.19	-70.80	-13.00	-57.80	peak	H
7	4120.000	-66.93	16.61	-50.32	-13.00	-37.32	peak	H
8	9892.000	-66.76	31.92	-34.84	-13.00	-21.84	peak	H
9	10720.000	-68.22	35.11	-33.11	-13.00	-20.11	peak	H
1	129.0000	-73.09	13.37	-59.72	-13.00	-46.72	peak	V
2	278.5000	-80.59	0.72	-79.87	-13.00	-66.87	peak	V
3	544.5000	-80.72	4.29	-76.43	-13.00	-63.43	peak	V
4	696.0000	-79.04	10.07	-68.97	-13.00	-55.97	peak	V
5	771.0000	-78.63	11.13	-67.50	-13.00	-54.50	peak	V
6	970.5000	-88.63	12.46	-76.17	-13.00	-63.17	peak	V
7	5020.000	-70.28	23.45	-46.83	-13.00	-33.83	peak	V
8	10708.000	-69.83	34.67	-35.16	-13.00	-22.16	peak	V
9	11488.000	-71.02	38.03	-32.99	-13.00	-19.99	peak	V

Standard:	FCC Part 22	Test Distance:	3m
Test item:	Radiated Emission	Power:	AC 120V/60Hz
Model:	PJ03120	Temp.(°C)/Hum.(%RH):	26(°C)/60%RH
Mode:	Mode 4	Date:	10/06/2011
Frequency:	846.4 MHz	Test By:	Gary Wu

No.	Frequency (MHz)	Reading (dBm)	Correct Factor(dB)	Result (dBm)	Limit (dBm)	Margin (dB)	Remark	Ant.Polar. H / V
1	36.5000	-71.88	8.59	-63.29	-13.00	-50.29	peak	H
2	55.0000	-74.47	6.28	-68.19	-13.00	-55.19	peak	H
3	92.5000	-68.65	-0.43	-69.08	-13.00	-56.08	peak	H
4	155.5000	-65.94	0.01	-65.93	-13.00	-52.93	peak	H
5	358.0000	-80.41	-0.02	-80.43	-13.00	-67.43	peak	H
6	552.5000	-79.56	7.97	-71.59	-13.00	-58.59	peak	H
7	3292.000	-65.85	14.85	-51.00	-13.00	-38.00	peak	H
8	6676.000	-70.16	26.65	-43.51	-13.00	-30.51	peak	H
9	8236.000	-70.46	29.22	-41.24	-13.00	-28.24	peak	H
1	130.5000	-71.68	14.10	-57.58	-13.00	-44.58	peak	V
2	152.5000	-70.58	9.08	-61.50	-13.00	-48.50	peak	V
3	197.5000	-78.76	7.81	-70.95	-13.00	-57.95	peak	V
4	304.5000	-82.90	2.33	-80.57	-13.00	-67.57	peak	V
5	525.0000	-81.53	3.40	-78.13	-13.00	-65.13	peak	V
6	701.5000	-75.91	10.24	-65.67	-13.00	-52.67	peak	V
7	3292.000	-67.46	18.23	-49.23	-13.00	-36.23	peak	V
8	8548.000	-70.98	25.89	-45.09	-13.00	-32.09	peak	V
9	10624.000	-71.97	34.08	-37.89	-13.00	-24.89	peak	V

## 7 Frequency Stability (Temperature Variation) Test

### 7.1. Limit

The frequency stability shall be measured by variation of ambient temperature and variation of primary supply voltage to ensure that the fundamental emission stays within the authorized frequency block. The frequency stability of the transmitter shall be maintained within  $\pm 0.00025\%$  ( $\pm 2.5\text{ppm}$ ) of the center frequency.

### 7.2. Test Instruments

Describe	Manufacturer	Model No.	Serial No.	Cal. Date	Remark
Universal Radio Communication Tester	ROHDE & SCHWARZ	CMU200	109369	08/10/2010	(2)
Temperature & Humidity Chamber	TAICHY	MHU-225LA	980729	08/24/2011	(1)
Test Site	ATL	TE02	TE02	N.C.R.	-----

Remark: <sup>(1)</sup> Calibration period 1 year. <sup>(2)</sup> Calibration period 2 years.

NOTE: N.C.R. = No Calibration Request.

### 7.3. Setup

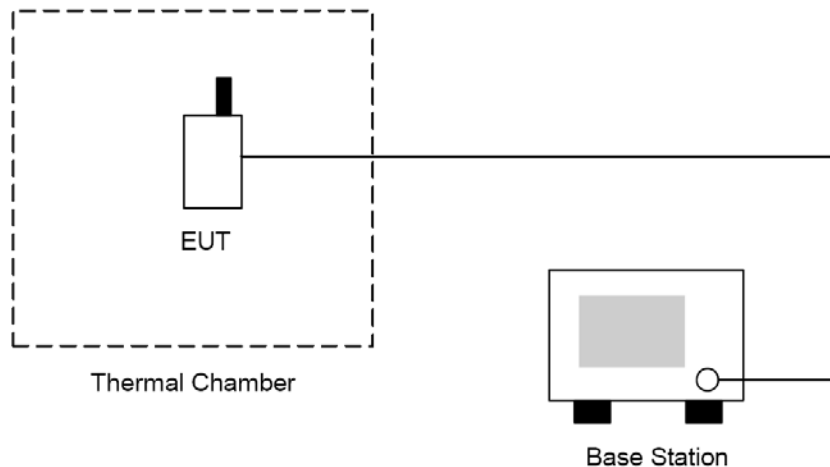

#### **7.4. Test Procedure**

The measurement is made according to FCC rules part 22 and 24:

1. The EUT and test equipment were set up as shown on the following section.
2. With all power removed, the temperature was decreased to  $-30^{\circ}\text{C}$  and permitted to stabilize for three hours. Power was applied and the maximum change in frequency was note within one minute.
3. With power OFF, the temperature was raised in  $10^{\circ}\text{C}$  steps. The sample was permitted to stabilize at each step for at least one-half hour. Power was applied and the maximum frequency change was noted within one minute.
4. The temperature tests were performed for the worst case.
5. Test data was recorded.

#### **7.5. Uncertainty**

The measurement uncertainty is defined as for Frequency Stability (Temperature Variation) measurement is  $\pm 10\text{Hz}$ .

**7.6. Test Result**

Model Number	PJ03120			
Test Item	Frequency Stability (Temperature Variation)			
Test Mode	Mode 1: GSM 850 Link			
Date of Test	09/13/2011		Test Site	TE02
Temperature (°C)	Deviation (Hz)	Deviation (ppm)	Limit (ppm)	Result
-30	55	0.066	±2.5	Pass
-20	53	0.063	±2.5	Pass
-10	54	0.065	±2.5	Pass
0	52	0.062	±2.5	Pass
10	55	0.066	±2.5	Pass
20	56	0.067	±2.5	Pass
30	53	0.063	±2.5	Pass
40	52	0.062	±2.5	Pass
50	53	0.063	±2.5	Pass

Model Number	PJ03120			
Test Item	Frequency Stability (Temperature Variation)			
Test Mode	Mode 2: GSM 1900 Link			
Date of Test	09/13/2011		Test Site	TE02
Temperature (°C)	Deviation (Hz)	Deviation (ppm)	Limit (ppm)	Result
-30	-53	-0.028	±2.5	Pass
-20	-55	-0.029	±2.5	Pass
-10	-54	-0.029	±2.5	Pass
0	-55	-0.029	±2.5	Pass
10	-53	-0.028	±2.5	Pass
20	-55	-0.029	±2.5	Pass
30	-56	-0.030	±2.5	Pass
40	-52	-0.028	±2.5	Pass
50	-53	-0.028	±2.5	Pass

Model Number	PJ03120			
Test Item	Frequency Stability (Temperature Variation)			
Test Mode	Mode 3: WCDMA Band II Link			
Date of Test	09/13/2011		Test Site	TE02
Temperature (°C)	Deviation (Hz)	Deviation (ppm)	Limit (ppm)	Result
-30	-37	-0.020	±2.5	Pass
-20	-38	-0.020	±2.5	Pass
-10	-36	-0.019	±2.5	Pass
0	-38	-0.020	±2.5	Pass
10	-37	-0.020	±2.5	Pass
20	-38	-0.020	±2.5	Pass
30	-36	-0.019	±2.5	Pass
40	-37	-0.020	±2.5	Pass
50	-38	-0.020	±2.5	Pass

Model Number	PJ03120			
Test Item	Frequency Stability (Temperature Variation)			
Test Mode	Mode 4: WCDMA Band V Link			
Date of Test	09/13/2011		Test Site	TE02
Temperature (°C)	Deviation (Hz)	Deviation (ppm)	Limit (ppm)	Result
-30	-19	-0.023	±2.5	Pass
-20	-18	-0.022	±2.5	Pass
-10	-19	-0.023	±2.5	Pass
0	-20	-0.024	±2.5	Pass
10	-21	-0.025	±2.5	Pass
20	-19	-0.023	±2.5	Pass
30	-18	-0.022	±2.5	Pass
40	-19	-0.023	±2.5	Pass
50	-19	-0.023	±2.5	Pass

## 8 Frequency Stability (Voltage Variation) Test

### 8.1. Limit

The frequency stability shall be measured by variation of ambient temperature and variation of primary supply voltage to ensure that the fundamental emission stays within the authorized frequency block. The frequency stability of the transmitter shall be maintained within  $\pm 0.00025\%$  ( $\pm 2.5\text{ppm}$ ) of the center frequency.

### 8.2. Test Instruments

Describe	Manufacturer	Model No.	Serial No.	Cal. Date	Remark
Universal Radio Communication Tester	ROHDE & SCHWARZ	CMU200	109369	08/10/2010	(2)
Temperature & Humidity Chamber	TAICHY	MHU-225LA	980729	08/24/2011	(1)
Test Site	ATL	TE02	TE02	N.C.R.	-----

Remark: <sup>(1)</sup> Calibration period 1 year. <sup>(2)</sup> Calibration period 2 years.

NOTE: N.C.R. = No Calibration Request.

### 8.3. Setup

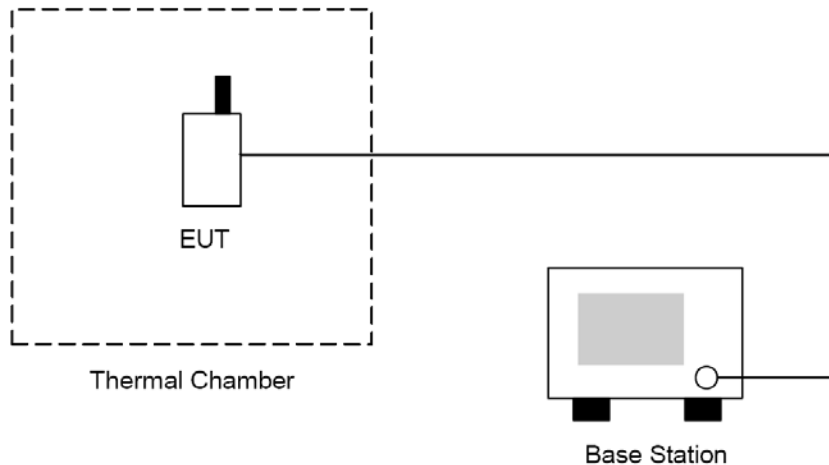

### 8.4. Test Procedure

1. The EUT was placed in a temperature chamber at  $25 \pm 5^\circ\text{C}$  and connected as the following section.
2. The power supply voltage to the EUT was varied from BEP to 115% of the nominal value measured at the input to the EUT.
3. The variation in frequency was measured for the worst case.

## 8.5. Uncertainty

The measurement uncertainty is defined as for Frequency Stability (Voltage Variation) measurement is  $\pm 10\text{Hz}$ .

## 8.6. Test Result

Model Number	PJ03120				
Test Item	Frequency Stability (Voltage Variation)				
Test Mode	Mode 1: GSM 850 Link				
Date of Test	09/13/2011		Test Site	TE02	
Level	Voltage [V]	Deviation [Hz]	Deviation [ppm]	Limit [ppm]	Result
Battery full point	4.07	56	0.067	$\pm 2.5$	Pass
Normal	3.70	54	0.065	$\pm 2.5$	Pass
Battery cut-off point	3.40	55	0.066	$\pm 2.5$	Pass

Model Number	PJ03120				
Test Item	Frequency Stability (Voltage Variation)				
Test Mode	Mode 2: GSM 1900 Link				
Date of Test	09/13/2011		Test Site	TE02	
Level	Voltage [V]	Deviation [Hz]	Deviation [ppm]	Limit [ppm]	Result
Battery full point	4.07	-55	-0.029	$\pm 2.5$	Pass
Normal	3.70	-57	-0.030	$\pm 2.5$	Pass
Battery cut-off point	3.40	-56	-0.030	$\pm 2.5$	Pass

Model Number	PJ03120				
Test Item	Frequency Stability (Voltage Variation)				
Test Mode	Mode 3: WCDMA Band II Link				
Date of Test	09/13/2011		Test Site	TE02	
Level	Voltage [V]	Deviation [Hz]	Deviation [ppm]	Limit [ppm]	Result
Battery full point	4.07	-20	-0.024	$\pm 2.5$	Pass
Normal	3.70	-18	-0.022	$\pm 2.5$	Pass
Battery cut-off point	3.40	-21	-0.025	$\pm 2.5$	Pass



Model Number	PJ03120				
Test Item	Frequency Stability (Voltage Variation)				
Test Mode	Mode 4: WCDMA Band V Link				
Date of Test	09/13/2011		Test Site	TE02	
Level	Voltage [V]	Deviation [Hz]	Deviation [ppm]	Limit [ppm]	Result
Battery full point	4.07	-36	-0.019	±2.5	Pass
Normal	3.70	-38	-0.020	±2.5	Pass
Battery cut-off point	3.40	-37	-0.020	±2.5	Pass

## 9 AC Power Conducted Emissions Test

### 9.1. Limit

Frequency range (MHz)	Limits (dBuV)	
	Quasi-peak	Average
0.15 to 0.50	66 to 56	56 to 46
0.50 to 5.0	56	46
5.0 to 30	60	50

### 9.2. Test Instruments

Describe	Manufacturer	Model No.	Serial No.	Cal. Date	Remark
Test Receiver	R&S	ESCI	100367	06/30/2011	(1)
LISN	R&S	ENV216	101040	03/04/2011	(1)
LISN	R&S	ENV216	101041	03/04/2011	(1)
Test Site	ATL	TE02	TE02	N.C.R.	-----

Remark: <sup>(1)</sup> Calibration period 1 year. <sup>(2)</sup> Calibration period 2 years.

NOTE: N.C.R. = No Calibration Request.

### 9.3. Setup

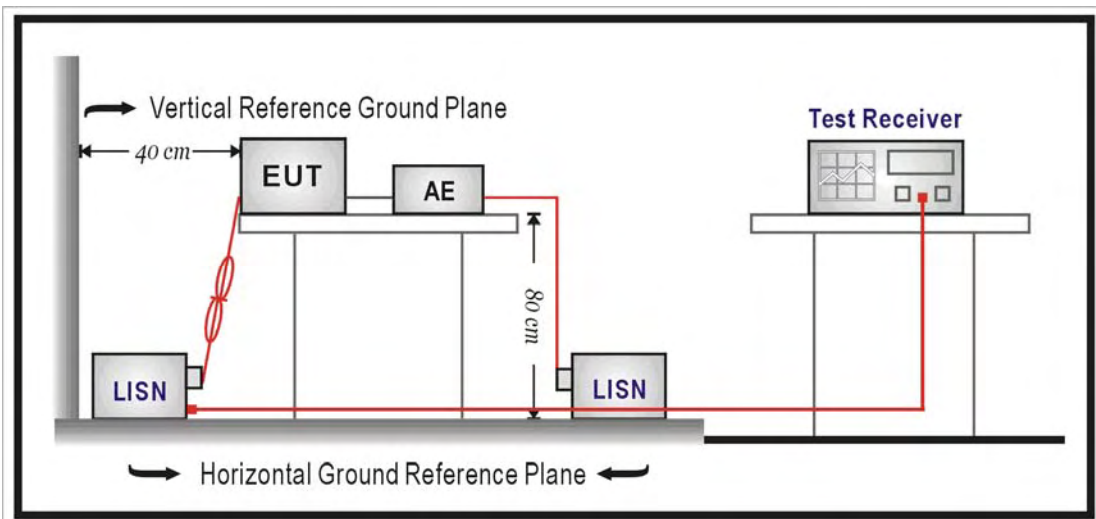

#### **9.4. Test Procedure**

The measurement is made according to FCC rules 15.207:

The power line conducted emission measurements were performed in a shielded enclosure. The EUT was assembled on a wooden table which is 80 centimeters high, was placed 40 centimeters from the back wall and at least 1 meter from the sidewall.

Power was fed to the EUT from the public utility power grid through a line filter and EMCO Model 3162/2 SH Line Impedance Stabilization Networks (LISN). The LISN housing, measuring instrumentation case, ground plane, etc., were electrically bonded together at the same RF potential. The Spectrum analyzer was connected to the AC line through an isolation transformer. The 50-ohm output of the LISN was connected to the spectrum analyzer directly. Conducted emission levels were in the CISPR quasi-peak detection mode. The analyzer's 6 dB bandwidth was set to 9 KHz. No post-detector video filter was used.

The spectrum was scanned from 150 KHz to 30 MHz. The physical arrangement of the test system and associated cabling was varied (within the scope of arrangements likely to be encountered in actual use) to determine the effect on the unit's emanations in amplitude and frequency. All spurious emission frequencies were observed. The highest emission amplitudes relative to the appropriate limit were measured and have been recorded in section 10.6.

#### **9.5. Uncertainty**

The measurement uncertainty is defined as for AC power conducted emission measurement is  $\pm 2.24$  dB.

**9.6. Test Result**

Standard:	FCC Part 22H	Line:	L1
Test item:	Conducted Emission	Power:	AC 120V/60Hz
Model:	PJ03120	Temp.(°C)/Hum.(%RH):	26(°C)/60%RH
Mode:	Mode 1	Date:	09/09/2011
		Test By:	Gary Wu
Description:			

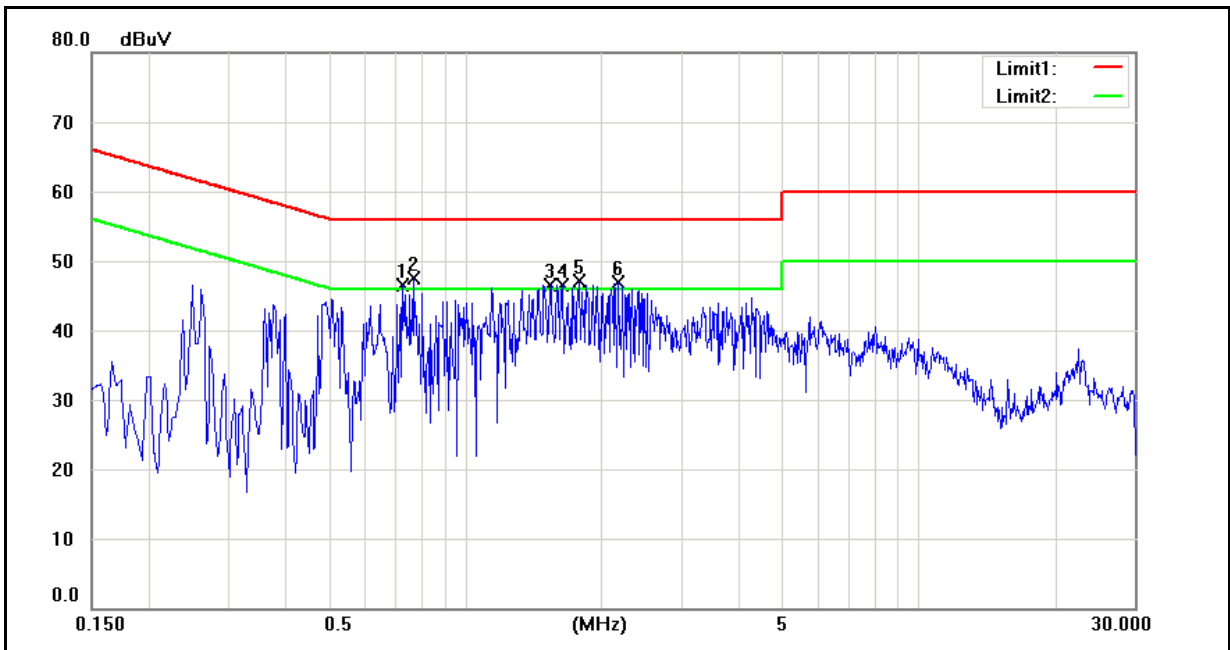

No.	Frequency (MHz)	QP reading (dBuV)	AVG reading (dBuV)	Correction factor (dB)	QP result (dBuV)	AVG result (dBuV)	QP limit (dBuV)	AVG limit (dBuV)	QP margin (dB)	AVG margin (dB)	Remark
1	0.7300	31.49	17.79	9.84	41.33	27.63	56.00	46.00	-14.67	-18.37	Pass
2	0.7700	32.04	23.62	9.83	41.87	33.45	56.00	46.00	-14.13	-12.55	Pass
3	1.5380	29.26	16.61	9.69	38.95	26.30	56.00	46.00	-17.05	-19.70	Pass
4	1.6420	28.48	14.10	9.69	38.17	23.79	56.00	46.00	-17.83	-22.21	Pass
5	1.7820	30.13	13.54	9.68	39.81	23.22	56.00	46.00	-16.19	-22.78	Pass
6	2.1740	30.19	16.28	9.70	39.89	25.98	56.00	46.00	-16.11	-20.02	Pass

Standard:	FCC Part 22H	Line:	N
Test item:	Conducted Emission	Power:	AC 120V/60Hz
Model:	PJ03120	Temp.(°C)/Hum.(%RH):	26(°C)/60%RH
Mode:	Mode 1	Date:	09/09/2011
		Test By:	Gary Wu
Description:			

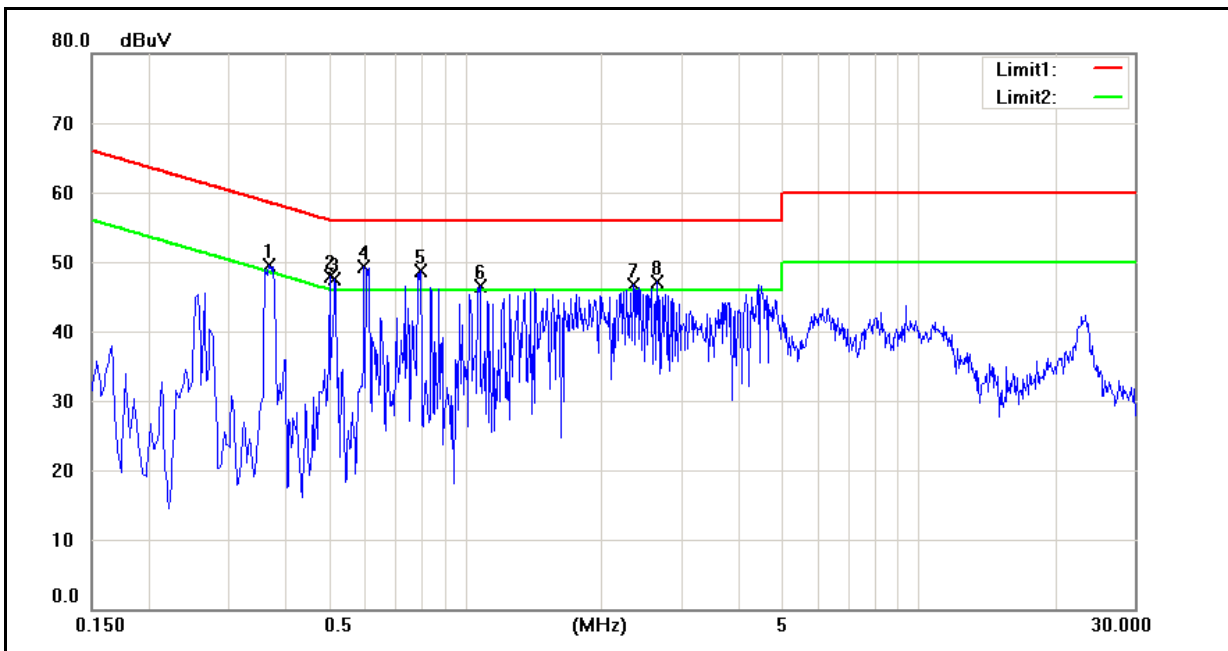

No.	Frequency (MHz)	QP reading (dBuV)	AVG reading (dBuV)	Correction factor (dB)	QP result (dBuV)	AVG result (dBuV)	QP limit (dBuV)	AVG limit (dBuV)	QP margin (dB)	AVG margin (dB)	Remark
1	0.3700	34.75	16.36	10.06	44.81	26.42	58.50	48.50	-13.69	-22.08	Pass
2	0.5020	32.50	15.01	10.01	42.51	25.02	56.00	46.00	-13.49	-20.98	Pass
3	0.5180	33.10	13.88	10.00	43.10	23.88	56.00	46.00	-12.90	-22.12	Pass
4	0.5980	33.99	16.88	9.97	43.96	26.85	56.00	46.00	-12.04	-19.15	Pass
5	0.7980	31.97	20.67	9.88	41.85	30.55	56.00	46.00	-14.15	-15.45	Pass
6	1.0780	31.10	12.98	9.79	40.89	22.77	56.00	46.00	-15.11	-23.23	Pass
7	2.3500	29.68	11.08	9.78	39.46	20.86	56.00	46.00	-16.54	-25.14	Pass

Standard:	FCC Part 24E	Line:	L1
Test item:	Conducted Emission	Power:	AC 120V/60Hz
Model:	PJ03120	Temp.(°C)/Hum.(%RH):	26(°C)/60%RH
Mode:	Mode 2	Date:	09/09/2011
		Test By:	Gary Wu
Description:			

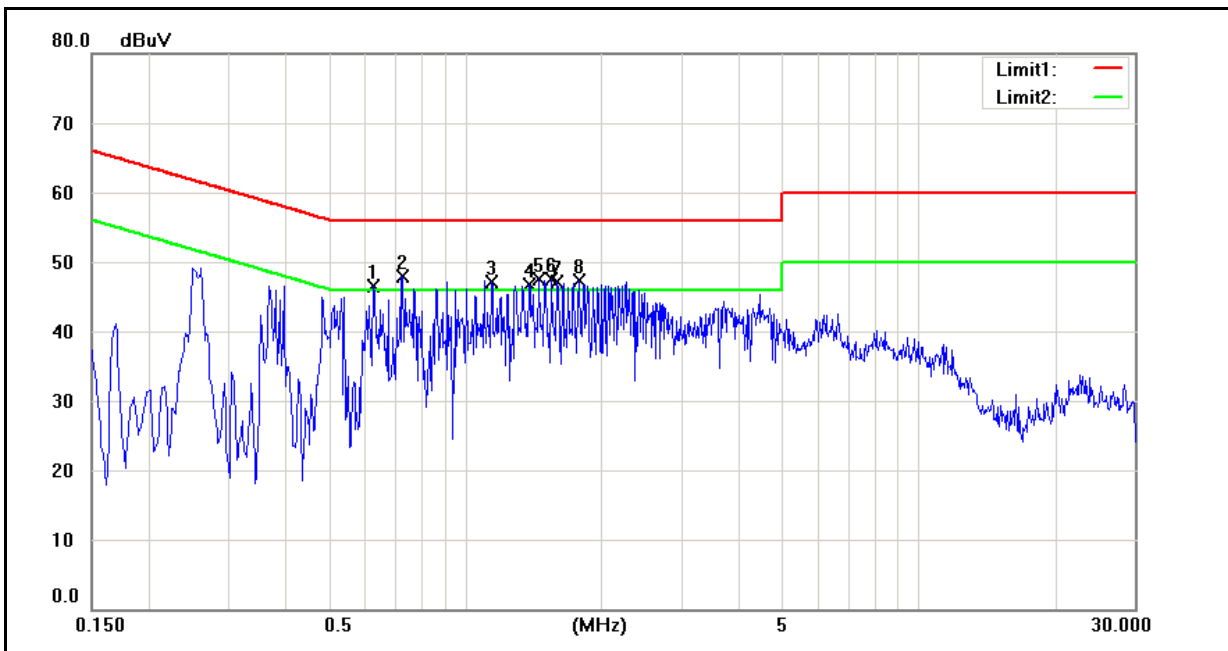

No.	Frequency (MHz)	QP reading (dBuV)	AVG reading (dBuV)	Correction factor (dB)	QP result (dBuV)	AVG result (dBuV)	QP limit (dBuV)	AVG limit (dBuV)	QP margin (dB)	AVG margin (dB)	Remark
1	0.6300	31.78	20.50	9.88	41.66	30.38	56.00	46.00	-14.34	-15.62	Pass
2	0.7300	31.74	18.21	9.84	41.58	28.05	56.00	46.00	-14.42	-17.95	Pass
3	1.1460	30.81	11.11	9.72	40.53	20.83	56.00	46.00	-15.47	-25.17	Pass
4	1.3860	29.46	13.74	9.69	39.15	23.43	56.00	46.00	-16.85	-22.57	Pass
5	1.4580	31.60	16.75	9.68	41.28	26.43	56.00	46.00	-14.72	-19.57	Pass
6	1.5580	31.43	18.13	9.69	41.12	27.82	56.00	46.00	-14.88	-18.18	Pass
7	1.5940	31.35	17.47	9.69	41.04	27.16	56.00	46.00	-14.96	-18.84	Pass
8	1.7820	30.60	13.38	9.68	40.28	23.06	56.00	46.00	-15.72	-22.94	Pass

Standard:	FCC Part 24E	Line:	N
Test item:	Conducted Emission	Power:	AC 120V/60Hz
Model:	PJ03120	Temp.(°C)/Hum.(%RH):	26(°C)/60%RH
Mode:	Mode 2	Date:	09/09/2011
		Test By:	Gary Wu
Description:			

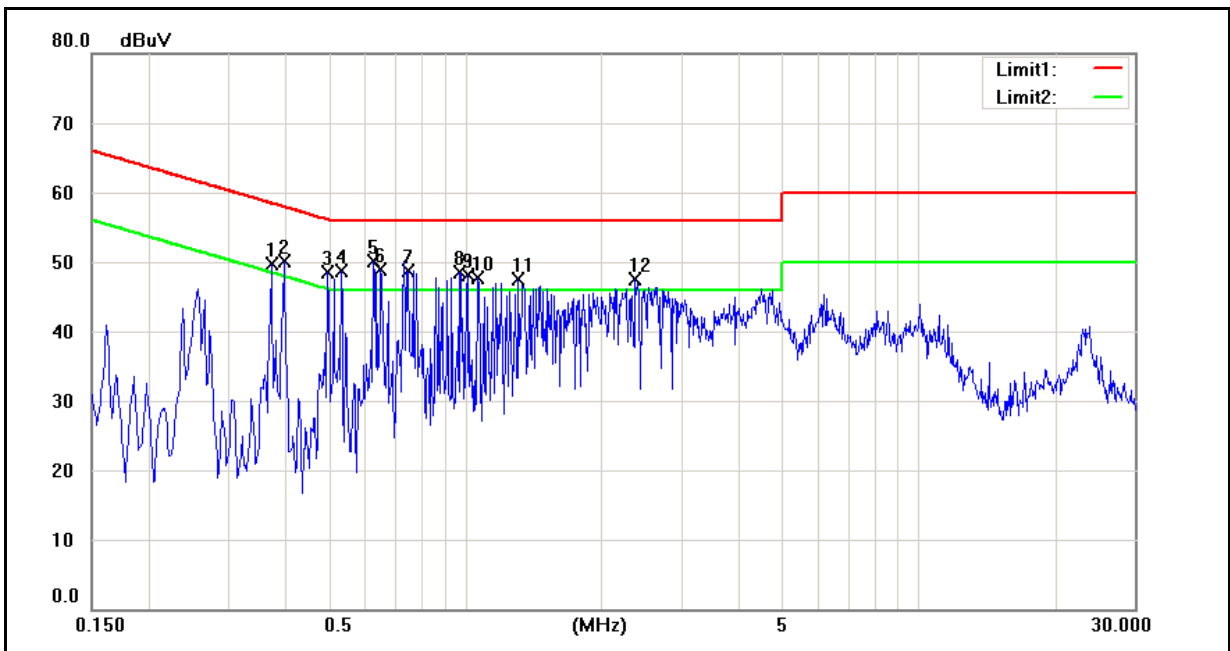

No.	Frequency (MHz)	QP reading (dBuV)	AVG reading (dBuV)	Correction factor (dB)	QP result (dBuV)	AVG result (dBuV)	QP limit (dBuV)	AVG limit (dBuV)	QP margin (dB)	AVG margin (dB)	Remark
1	0.3740	36.31	15.33	10.06	46.37	25.39	58.41	48.41	-12.04	-23.02	Pass
2	0.3980	36.11	15.98	10.05	46.16	26.03	57.90	47.90	-11.74	-21.87	Pass
3	0.4980	33.94	12.54	10.01	43.95	22.55	56.03	46.03	-12.08	-23.48	Pass
4	0.5340	33.51	14.14	10.00	43.51	24.14	56.00	46.00	-12.49	-21.86	Pass
5	0.6300	34.29	18.13	9.96	44.25	28.09	56.00	46.00	-11.75	-17.91	Pass
6	0.6540	33.75	13.29	9.95	43.70	23.24	56.00	46.00	-12.30	-22.76	Pass
7	0.7500	32.87	21.90	9.91	42.78	31.81	56.00	46.00	-13.22	-14.19	Pass
8	0.9700	32.21	12.89	9.81	42.02	22.70	56.00	46.00	-13.98	-23.30	Pass
9	1.0180	31.64	11.58	9.80	41.44	21.38	56.00	46.00	-14.56	-24.62	Pass
10	1.0660	30.74	10.04	9.79	40.53	19.83	56.00	46.00	-15.47	-26.17	Pass
11	1.3100	31.59	15.67	9.77	41.36	25.44	56.00	46.00	-14.64	-20.56	Pass
12	2.3820	30.62	12.52	9.79	40.41	22.31	56.00	46.00	-15.59	-23.69	Pass

Standard:	FCC Part 24E	Line:	L1
Test item:	Conducted Emission	Power:	AC 120V/60Hz
Model:	PJ03120	Temp.(°C)/Hum.(%RH):	26(°C)/60%RH
Mode:	Mode 3	Date:	09/09/2011
		Test By:	Gary Wu
Description:			

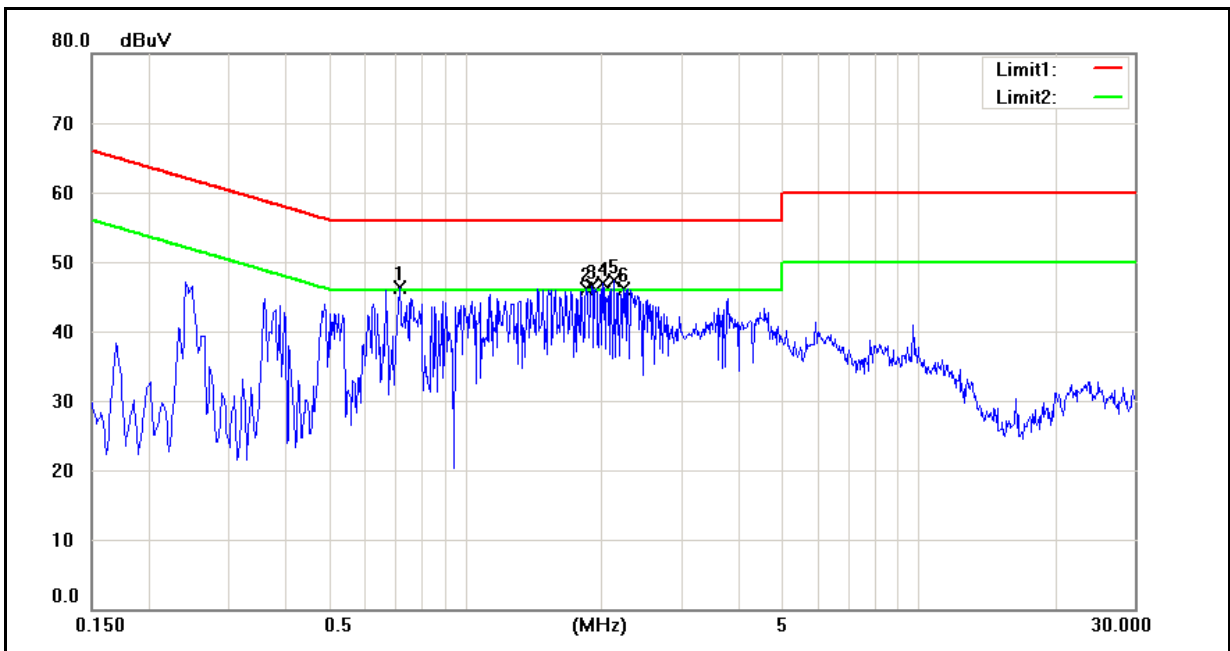

No.	Frequency (MHz)	QP reading (dBuV)	AVG reading (dBuV)	Correction factor (dB)	QP result (dBuV)	AVG result (dBuV)	QP limit (dBuV)	AVG limit (dBuV)	QP margin (dB)	AVG margin (dB)	Remark
1	0.7180	30.79	22.17	9.85	40.64	32.02	56.00	46.00	-15.36	-13.98	Pass
2	1.8580	30.80	12.96	9.68	40.48	22.64	56.00	46.00	-15.52	-23.36	Pass
3	1.9060	31.55	11.37	9.68	41.23	21.05	56.00	46.00	-14.77	-24.95	Pass
4	2.0220	31.62	14.85	9.68	41.30	24.53	56.00	46.00	-14.70	-21.47	Pass
5	2.1420	31.52	16.99	9.70	41.22	26.69	56.00	46.00	-14.78	-19.31	Pass
6	2.2460	30.05	15.13	9.71	39.76	24.84	56.00	46.00	-16.24	-21.16	Pass



Standard:	FCC Part 24E	Line:	N
Test item:	Conducted Emission	Power:	AC 120V/60Hz
Model:	PJ03120	Temp.(°C)/Hum.(%RH):	26(°C)/60%RH
Mode:	Mode 3	Date:	09/09/2011
		Test By:	Gary Wu
Description:			

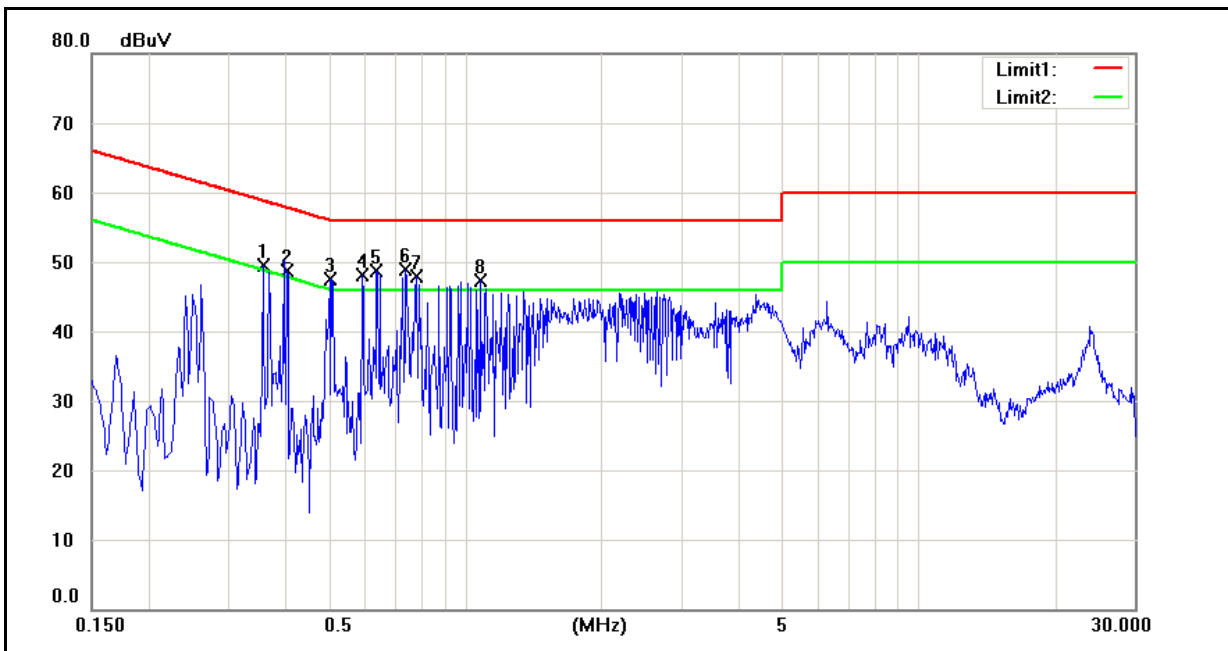

No.	Frequency (MHz)	QP reading (dBuV)	AVG reading (dBuV)	Correction factor (dB)	QP result (dBuV)	AVG result (dBuV)	QP limit (dBuV)	AVG limit (dBuV)	QP margin (dB)	AVG margin (dB)	Remark
1	0.3580	35.00	13.62	10.07	45.07	23.69	58.77	48.77	-13.70	-25.08	Pass
2	0.4060	31.98	7.49	10.05	42.03	17.54	57.73	47.73	-15.70	-30.19	Pass
3	0.5020	33.28	12.59	10.01	43.29	22.60	56.00	46.00	-12.71	-23.40	Pass
4	0.5940	32.19	11.88	9.97	42.16	21.85	56.00	46.00	-13.84	-24.15	Pass
5	0.6380	33.68	12.15	9.95	43.63	22.10	56.00	46.00	-12.37	-23.90	Pass
6	0.7420	32.19	19.98	9.91	42.10	29.89	56.00	46.00	-13.90	-16.11	Pass
7	0.7820	32.19	21.15	9.89	42.08	31.04	56.00	46.00	-13.92	-14.96	Pass
8	1.0780	31.44	12.64	9.79	41.23	22.43	56.00	46.00	-14.77	-23.57	Pass

Standard:	FCC Part 22H	Line:	L1
Test item:	Conducted Emission	Power:	AC 120V/60Hz
Model:	PJ03120	Temp.(°C)/Hum.(%RH):	26(°C)/60%RH
Mode:	Mode 4	Date:	09/09/2011
		Test By:	Gary Wu
Description:			

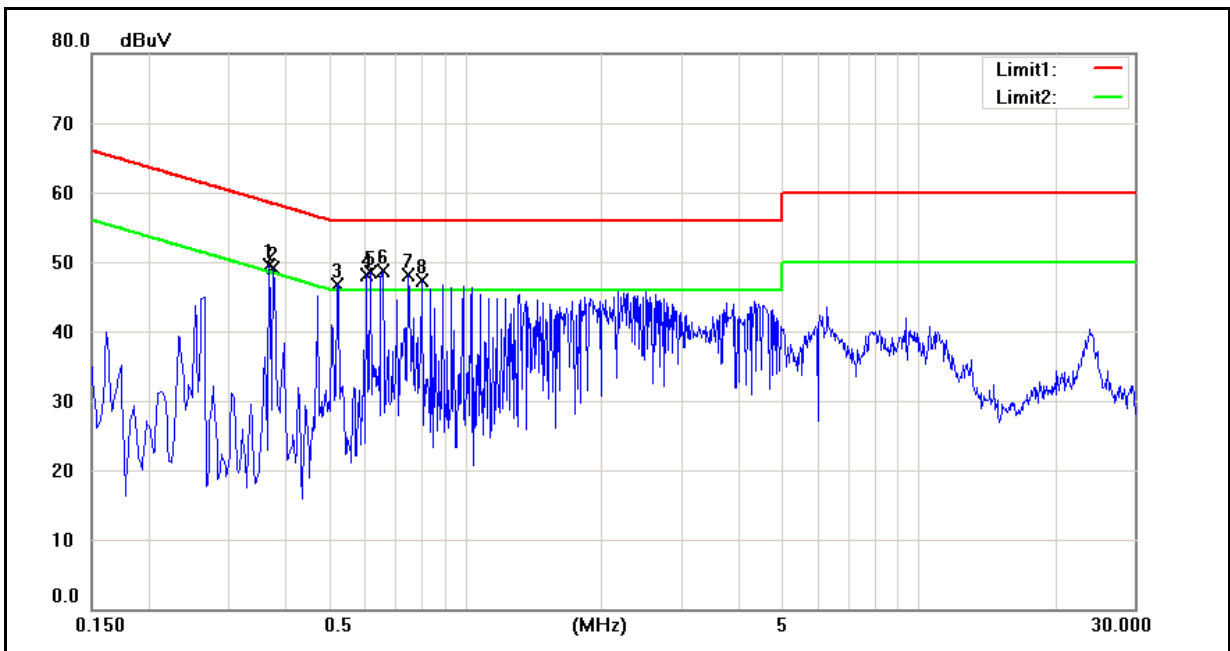

No.	Frequency (MHz)	QP reading (dBuV)	AVG reading (dBuV)	Correction factor (dB)	QP result (dBuV)	AVG result (dBuV)	QP limit (dBuV)	AVG limit (dBuV)	QP margin (dB)	AVG margin (dB)	Remark
1	0.3700	35.28	15.44	10.06	45.34	25.50	58.50	48.50	-13.16	-23.00	Pass
2	0.3780	35.39	13.22	10.06	45.45	23.28	58.32	48.32	-12.87	-25.04	Pass
3	0.5220	32.83	14.97	10.00	42.83	24.97	56.00	46.00	-13.17	-21.03	Pass
4	0.6060	33.72	11.50	9.97	43.69	21.47	56.00	46.00	-12.31	-24.53	Pass
5	0.6180	33.66	14.99	9.96	43.62	24.95	56.00	46.00	-12.38	-21.05	Pass
6	0.6580	32.79	16.32	9.94	42.73	26.26	56.00	46.00	-13.27	-19.74	Pass
7	0.7500	31.86	22.02	9.91	41.77	31.93	56.00	46.00	-14.23	-14.07	Pass
8	0.8060	31.28	12.87	9.88	41.16	22.75	56.00	46.00	-14.84	-23.25	Pass

Standard:	FCC Part 22H	Line:	N
Test item:	Conducted Emission	Power:	AC 120V/60Hz
Model:	PJ03120	Temp.(°C)/Hum.(%RH):	26(°C)/60%RH
Mode:	Mode 4	Date:	09/09/2011
		Test By:	Gary Wu
Description:			

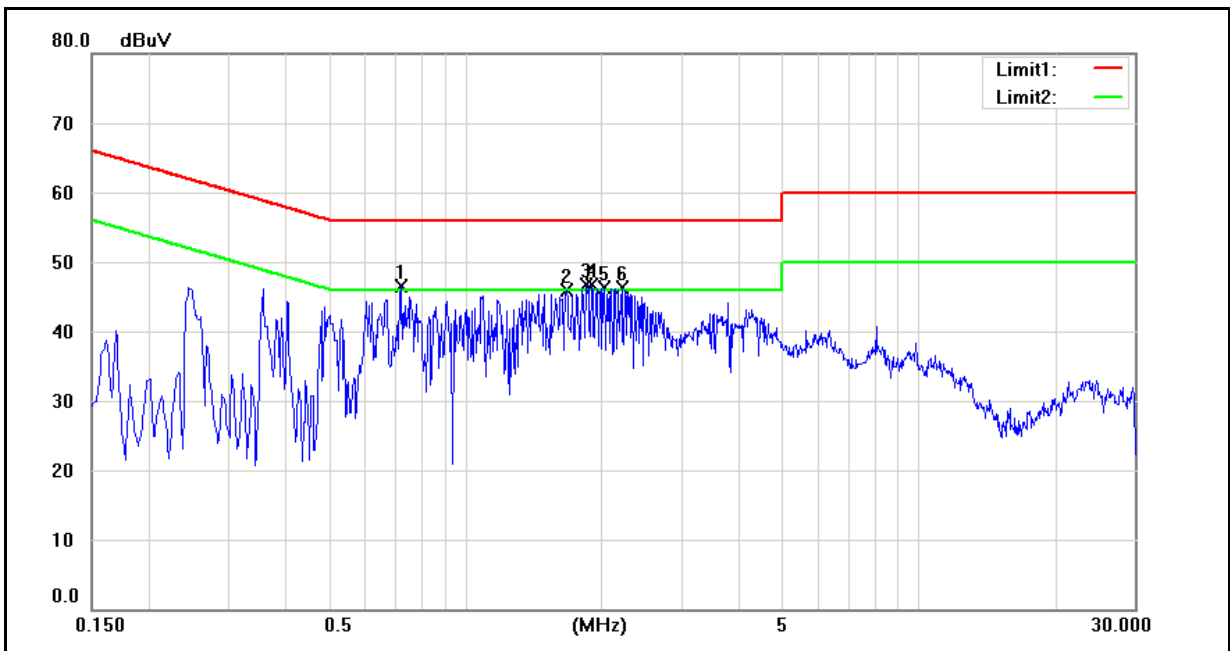

No.	Frequency (MHz)	QP reading (dBuV)	AVG reading (dBuV)	Correction factor (dB)	QP result (dBuV)	AVG result (dBuV)	QP limit (dBuV)	AVG limit (dBuV)	QP margin (dB)	AVG margin (dB)	Remark
1	0.7260	30.20	21.80	9.85	40.05	31.65	56.00	46.00	-15.95	-14.35	Pass
2	1.6740	29.88	15.41	9.69	39.57	25.10	56.00	46.00	-16.43	-20.90	Pass
3	1.8540	30.74	12.91	9.68	40.42	22.59	56.00	46.00	-15.58	-23.41	Pass
4	1.9020	31.13	11.34	9.68	40.81	21.02	56.00	46.00	-15.19	-24.98	Pass
5	2.0300	30.14	13.78	9.68	39.82	23.46	56.00	46.00	-16.18	-22.54	Pass