



FCC TEST REPORT

(Part 24)

REPORT NO.: RF110705C18-5

MODEL NO.: PH98100

FCC ID: NM8PH98100

RECEIVED: Jul. 05, 2011

TESTED: Jul. 08 ~ Jul. 28, 2011

ISSUED: Aug. 01, 2011

APPLICANT: HTC Corporation

ADDRESS: 6-3, Baoquang Rd., Xindian City, Taipei County, Taiwan

ISSUED BY: Bureau Veritas Consumer Products Services (H.K.) Ltd., Taoyuan Branch

LAB ADDRESS: No. 47, 14th Ling, Chia Pau Tsuen, Lin Kou Hsiang, Taipei Hsien 244, Taiwan, R.O.C.

TEST LOCATION: No. 19, Hwa Ya 2nd Rd, Wen Hwa Tsuen, Kwei Shan Hsiang, Taoyuan Hsien 333, Taiwan, R.O.C.

This test report consists of 61 pages in total. It may be duplicated completely for legal use with the approval of the applicant. It should not be reproduced except in full, without the written approval of our laboratory. The client should not use it to claim product endorsement by TAF or any government agencies. The test results in the report only apply to the tested sample.





TABLE OF CONTENTS

RELEASE CONTROL RECORD.....	4
1 CERTIFICATION	5
2 SUMMARY OF TEST RESULTS	6
2.1 MEASUREMENT UNCERTAINTY	6
3 GENERAL INFORMATION.....	7
3.1 GENERAL DESCRIPTION OF EUT	7
3.2 DESCRIPTION OF TEST MODES	8
3.2.1 CONFIGURATION OF SYSTEM UNDER TEST	9
3.2.2 TEST MODE APPLICABILITY AND TESTED CHANNEL DETAIL	10
3.3 GENERAL DESCRIPTION OF APPLIED STANDARDS	12
3.4 DESCRIPTION OF SUPPORT UNITS	12
4 TEST TYPES AND RESULTS	13
4.1 OUTPUT POWER MEASUREMENT	13
4.1.1 LIMITS OF OUTPUT POWER MEASUREMENT	13
4.1.2 TEST INSTRUMENTS.....	14
4.1.3 TEST PROCEDURES	15
4.1.4 TEST SETUP.....	16
4.1.5 EUT OPERATING CONDITIONS	16
4.1.6 TEST RESULTS	17
4.2 FREQUENCY STABILITY MEASUREMENT.....	19
4.2.1 LIMITS OF FREQUENCY STABILITY MEASUREMENT	19
4.2.2 TEST INSTRUMENTS.....	19
4.2.3 TEST PROCEDURE.....	20
4.2.4 TEST SETUP.....	20
4.2.5 TEST RESULTS	21
4.3 OCCUPIED BANDWIDTH MEASUREMENT	23
4.3.1 LIMITS OF OCCUPIED BANDWIDTH MEASUREMENT	23
4.3.2 TEST INSTRUMENTS.....	23
4.3.3 TEST SETUP.....	23
4.3.4 TEST PROCEDURES	24
4.3.5 EUT OPERATING CONDITION	24
4.3.6 TEST RESULTS	25
4.4 BAND EDGE MEASUREMENT.....	28
4.4.1 LIMITS OF BAND EDGE MEASUREMENT	28
4.4.2 TEST INSTRUMENTS.....	28
4.4.3 TEST SETUP.....	28
4.4.4 TEST PROCEDURES	29
4.4.5 EUT OPERATING CONDITION	29
4.4.6 TEST RESULTS	30
4.5 CONDUCTED SPURIOUS EMISSIONS	33
4.5.1 LIMITS OF CONDUCTED SPURIOUS EMISSIONS MEASUREMENT	33
4.5.2 TEST INSTRUMENTS.....	33
4.5.3 TEST PROCEDURE.....	34
4.5.4 TEST SETUP.....	34
4.5.5 EUT OPERATING CONDITIONS	34
4.5.6 TEST RESULTS	35
4.6 RADIATED EMISSION MEASUREMENT (BELOW 1GHz).....	45
4.6.1 LIMITS OF RADIATED EMISSION MEASUREMENT	45



4.6.2	TEST INSTRUMENTS.....	45
4.6.3	TEST PROCEDURES	46
4.6.4	DEVIATION FROM TEST STANDARD	46
4.6.5	TEST SETUP.....	47
4.6.6	EUT OPERATING CONDITIONS	47
4.6.7	TEST RESULTS	48
4.7	RADIATED EMISSION MEASUREMENT (ABOVE 1GHz)	50
4.7.1	LIMITS OF RADIATED EMISSION MEASUREMENT	50
4.7.2	TEST INSTRUMENTS.....	50
4.7.3	TEST PROCEDURES	51
4.7.4	DEVIATION FROM TEST STANDARD	51
4.7.5	TEST SETUP.....	52
4.7.6	EUT OPERATING CONDITIONS	52
4.7.7	TEST RESULTS	53
5	PHOTOGRAPHS OF THE TEST CONFIGURATION.....	59
6	INFORMATION ON THE TESTING LABORATORIES	60
7	APPENDIX A – MODIFICATIONS RECORDERS FOR ENGINEERING CHANGES TO THE EUT BY THE LAB	61



RELEASE CONTROL RECORD

ISSUE NO.	REASON FOR CHANGE	DATE ISSUED
Original release	N/A	Aug. 01, 2011



1 CERTIFICATION

PRODUCT: Smartphone

Model No.: PH98100

BRAND: HTC

APPLICANT: HTC Corporation

TEST SAMPLE: Production Unit

TESTED: Jul. 08 ~ Jul. 28, 2011

TEST STANDARDS: FCC Part 24, Subpart E
ANSI C63.4-2003

The above equipment (model: PH98100) has been tested by **Bureau Veritas Consumer Products Services (H.K.) Ltd., Taoyuan Branch**, and found compliance with the requirement of the above standards. The test record, data evaluation & Equipment Under Test (EUT) configurations represented herein are true and accurate accounts of the measurements of the sample's EMC characteristics under the conditions specified in this report.

PREPARED BY : Andrea Hsia , DATE : Aug. 01, 2011
Andrea Hsia / Specialist

APPROVED BY : Gary Chang , DATE : Aug. 01, 2011
Gary Chang / Assistant Manager



2 SUMMARY OF TEST RESULTS

The EUT has been tested according to the following specifications:

APPLIED STANDARD: FCC Part 24 & Part 2 / IC RSS-133			
STANDARD SECTION	TEST TYPE AND LIMIT	RESULT	REMARK
2.1046 24.232	Maximum Peak Output Power Limit: max. 2 watts e.i.r.p peak power	PASS	Meet the requirement of limit. Minimum passing margin is 25.1dBm at 1908.75MHz.
2.1055 24.235	Frequency Stability AFC Freq. Error vs. Voltage AFC Freq. Error vs. Temperature Limit: max. ± 2.5 ppm	PASS	Meet the requirement of limit.
2.1049 24.238(b)	Occupied Bandwidth	PASS	Meet the requirement of limit.
24.238(b)	Band Edge Measurements	PASS	Meet the requirement of limit.
2.1051 24.238	Conducted Spurious Emissions	PASS	Meet the requirement of limit.
2.1053 24.238	Radiated Spurious Emissions	PASS	Meet the requirement of limit. Minimum passing margin is -23.0 dB at 3702.5MHz.

2.1 MEASUREMENT UNCERTAINTY

Where relevant, the following measurement uncertainty levels have been estimated for tests performed on the EUT as specified in CISPR 16-4-2:

MEASUREMENT	FREQUENCY	UNCERTAINTY
Conducted emissions	9kHz~30MHz	2.44 dB
Radiated emissions	30MHz ~ 200MHz	3.34 dB
	200MHz ~1000MHz	3.35 dB
	1GHz ~ 18GHz	2.26 dB
	18GHz ~ 40GHz	1.94 dB

This uncertainty represents an expanded uncertainty expressed at approximately the 95% confidence level using a coverage factor of $k=2$.

3 GENERAL INFORMATION

3.1 GENERAL DESCRIPTION OF EUT

PRODUCT	Smartphone
MODEL NO.	PH98100
FCC ID	NM8PH98100
NOMINAL VOLTAGE	3.8Vdc (Li-Lon battery) 3.7Vdc (Li-Lon battery) 5Vdc (Adapter & host equipment)
OPERATION TEMPERATURE RANGE	-30°C ~ 50°C
MODULATION TYPE	QPSK, OQPSK, HPSK
FREQUENCY RANGE	1851.25MHz ~ 1908.75MHz
NUMBER OF CHANNEL	1151
MAX. EIRP POWER	EV-DO mode: 25.1dBm 1xRTT mode: 24.5dBm
ANTENNA TYPE	Fixed internal antenna with -1dBi gain
I/O PORTS	Refer to user's manual
DATA CABLE	Refer to note as below
ACCESSORY DEVICES	Refer to note as below

NOTE:

- The EUT's accessories list refers to Ext Pho_ NM8PH98100.pdf.
*Items 1, 3, 7, 8 were used for the test.
**After pretest of EIRP for standard (No.3) and extend battery (No.5) and found standard battery (No.3) has worse value than extend battery. Therefore, standard battery (No.3) is performed for all test items.
- The communicated functions of EUT listed as below:

		CDMA (850&1900MHz)	With 802.11a/b/g/n + Bluetooth + GPS functions
3G	CDMA	√	
	1*EVDO	√	

- MEID Code: 99000033xxxxxx.
- The above EUT information was declared by manufacturer and for more detailed features description, please refer to the manufacturer's specifications or User's Manual.

3.2 DESCRIPTION OF TEST MODES

The device includes CDMA and EV-DO transmitter. CDMA transmitter only supports 1x RTT without EV-DO mode. EV-DO transmitter only supports EV-DO without 1x RTT mode. 2 transmitters are tested separately for all test items.

For EV-DO, the low, middle and high channels are chosen for testing.

	CHANNEL	FREQUENCY	TX MODE
LOW	25	1851.25 MHz	1xEVDO Rev. 0
MIDDLE	600	1880.00 MHz	1xEVDO Rev. 0
HIGH	1175	1908.75 MHz	1xEVDO Rev. 0

NOTE:

1. Below 1 GHz, the channel 25, 600 and 1175 were pre-tested in chamber. The channel 1175 was the worst case and chosen for final test.
2. Above 1 GHz, the channel 25, 600 and 1175 were tested individually.
3. The channel space is 0.05MHz.
4. For EV-DO after pretest of output power and spurious emission under 1xEVDO Rev. 0 & 1xEVDO Rev. A mode, find the worst mode is 1xEVDO Rev. 0. Therefore, select 1xEVDO Rev. 0 mode to do final test

For 1xRTT the low, middle and high channels are chosen for testing.

	CHANNEL	FREQUENCY	TX MODE
LOW	25	1851.25 MHz	CDMA2000(SO55)
MIDDLE	600	1880.00 MHz	CDMA2000(SO55)
HIGH	1175	1908.75 MHz	CDMA2000(SO55)

NOTE:

1. Below 1 GHz, the channel 25, 600 and 1175 were pre-tested in chamber. The channel 600 was the worst case and chosen for final test.
2. Above 1 GHz, the channel 25, 600 and 1175 were tested individually.
3. The channel space is 0.05MHz.
4. After pretest of output power and spurious emission under CDMA2000(SO32), CDMA2000(SO2) & CDMA2000(SO55) mode, find the worst mode is CDMA2000(SO55). Therefore, select CDMA2000(SO55) mode to do final test

3.2.1 CONFIGURATION OF SYSTEM UNDER TEST

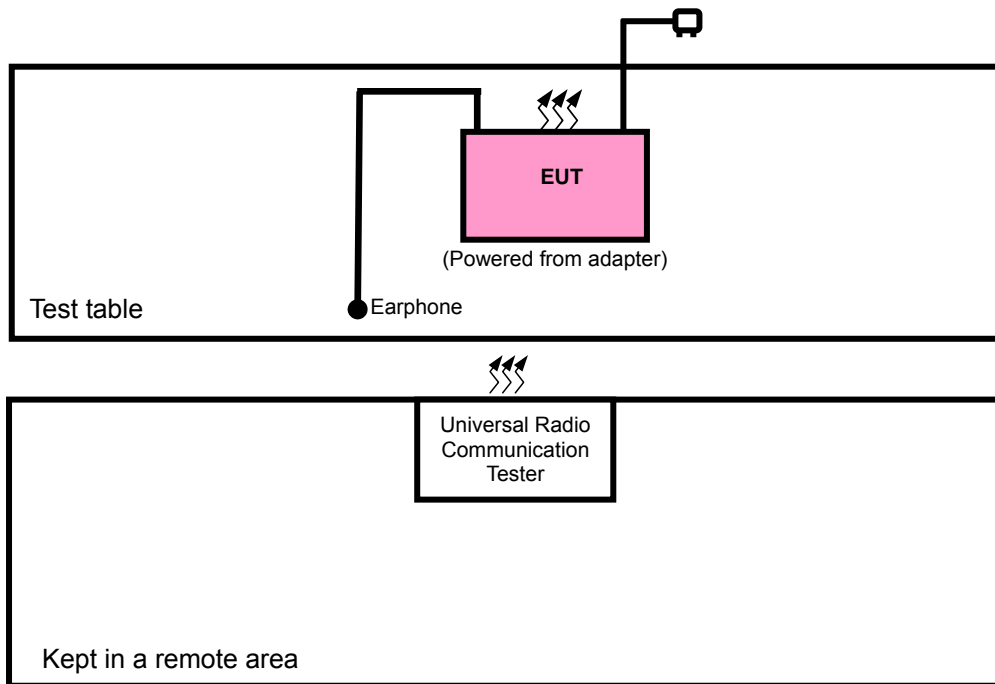



3.2.2 TEST MODE APPLICABILITY AND TESTED CHANNEL DETAIL

EUT CONFIGURE MODE	APPLICABLE TO							DESCRIPTION
	OP	FS	OB	BE	CE	RE<1G	RE≥1G	
A	√	√	√	√	√	√	√	For EVDO
B	√	√	√	√	√	√	√	For 1x RTT

Where **OP**: Output power
OB: Occupied bandwidth
CE: Conducted spurious emissions
RE≥1G: Radiated emission above 1GHz
FS: Frequency stability
BE: Band edge
RE<1G: Radiated emission below 1GHz

OUTPUT POWER MEASUREMENT:

- Pre-Scan has been conducted to determine the worst-case mode from all possible combinations between available modulations and antenna ports (if EUT with antenna diversity architecture).
- Following channel(s) was (were) selected for the final test as listed below.

EUT CONFIGURE MODE	AVAILABLE CHANNEL	TESTED CHANNEL
A & B	25 to 1175	25, 600, 1175

FREQUENCY STABILITY MEASUREMENT:

- Pre-Scan has been conducted to determine the worst-case mode from all possible combinations between available modulations and antenna ports (if EUT with antenna diversity architecture).
- Following channel(s) was (were) selected for the final test as listed below.

EUT CONFIGURE MODE	AVAILABLE CHANNEL	TESTED CHANNEL
A & B	25 to 1175	600

OCCUPIED BANDWIDTH MEASUREMENT:

- This item includes all test value of each mode, but only includes spectrum plot of worst value of each mode.
- Pre-Scan has been conducted to determine the worst-case mode from all possible combinations between available modulations and antenna ports (if EUT with antenna diversity architecture).
- Following channel(s) was (were) selected for the final test as listed below.

EUT CONFIGURE MODE	AVAILABLE CHANNEL	TESTED CHANNEL
A & B	25 to 1175	25, 600, 1175

BAND EDGE MEASUREMENT:

- Pre-Scan has been conducted to determine the worst-case mode from all possible combinations between available modulations and antenna ports (if EUT with antenna diversity architecture).
- Following channel(s) was (were) selected for the final test as listed below.

EUT CONFIGURE MODE	AVAILABLE CHANNEL	TESTED CHANNEL
A & B	25 to 1175	25, 1175



CONDUCTED SPURIOUS EMISSIONS MEASUREMENT:

- Pre-Scan has been conducted to determine the worst-case mode from all possible combinations between available modulations and antenna ports (if EUT with antenna diversity architecture).
- Following channel(s) was (were) selected for the final test as listed below.

EUT CONFIGURE MODE	AVAILABLE CHANNEL	TESTED CHANNEL
A & B	25 to 1175	25, 600, 1175

RADIATED EMISSION MEASUREMENT (BELOW 1 GHz):

- Pre-Scan has been conducted to determine the worst-case mode from all possible combinations between available modulations, XYZ axis and antenna ports (if EUT with antenna diversity architecture).
- Following channel(s) was (were) selected for the final test as listed below.

EUT CONFIGURE MODE	AVAILABLE CHANNEL	TESTED CHANNEL	AXIS
A	25 to 1175	1175	Y
B	25 to 1175	600	Y

RADIATED EMISSION MEASUREMENT (ABOVE 1 GHz):

- Pre-Scan has been conducted to determine the worst-case mode from all possible combinations between available modulations, XYZ axis and antenna ports (if EUT with antenna diversity architecture).
- Following channel(s) was (were) selected for the final test as listed below.

EUT CONFIGURE MODE	AVAILABLE CHANNEL	TESTED CHANNEL	AXIS
A & B	25 to 1175	25, 600, 1175	Y

TEST CONDITION:

APPLICABLE TO	ENVIRONMENTAL CONDITIONS	INPUT POWER (SYSTEM)	TESTED BY
OP	23deg. C, 63%RH	120Vac, 60Hz	Mark Liao
FS	23deg. C, 63%RH	120Vac, 60Hz	Mark Liao
OB	23deg. C, 63%RH	120Vac, 60Hz	Mark Liao
EM	23deg. C, 63%RH	120Vac, 60Hz	Mark Liao
BE	23deg. C, 63%RH	120Vac, 60Hz	Mark Liao
CE	23deg. C, 63%RH	120Vac, 60Hz	Mark Liao
RE < 1G	25deg. C, 65%RH	120Vac, 60Hz	David Huang
RE ≥ 1G	27deg. C, 65%RH	120Vac, 60Hz	Mark Liao



3.3 GENERAL DESCRIPTION OF APPLIED STANDARDS

The EUT is a RF product. According to the specifications of the manufacturer, it must comply with the requirements of the following standards:

FCC 47 CFR Part 2

FCC 47 CFR Part 24

IC RSS-133

ANSI C63.4-2003

ANSI/TIA/EIA-603-C 2004

NOTE: All test items have been performed and recorded as per the above standards.

3.4 DESCRIPTION OF SUPPORT UNITS

The EUT has been tested as an independent unit together with other necessary accessories or support units. The following support units or accessories were used to form a representative test configuration during the tests.

NO.	PRODUCT	BRAND	MODEL NO.	SERIAL NO.	FCC ID
1	UNIVERSAL RADIO COMMUNICATION TESTER	R&S	CMU200	104484	NA
2	NJZ-2000 (GPRS+WCDMA SIMULATOR)	JRC	NJZ-2000	ET00054	NA

NO.	SIGNAL CABLE DESCRIPTION OF THE ABOVE SUPPORT UNITS
1	NA
2	NA

NOTE 1: All power cords of the above support units are non shielded (1.8m).

NOTE 2: Item 1-2 acted as a communication partners to transfer data.



4 TEST TYPES AND RESULTS

4.1 OUTPUT POWER MEASUREMENT

4.1.1 LIMITS OF OUTPUT POWER MEASUREMENT

The radiated peak output power shall be according to the specific rule Part 24.232(b) that “Mobile / Portable station are limited to 2 watts e.i.r.p” and 24.232(c) specific that “Peak transmit power must be measure over any interval of continuous transmission using instrumentation calibration in terms of rms-equivalent voltage.”



4.1.2 TEST INSTRUMENTS

DESCRIPTION & MANUFACTURER	MODEL NO.	SERIAL NO.	DATE OF CALIBRATION	DUE DATE OF CALIBRATION
Test Receiver ROHDE & SCHWARZ	ESCI	100424	Aug. 04, 2010	Aug. 03, 2011
Spectrum Analyzer Agilent	E4446A	MY48250266	Aug. 11, 2010	Aug. 10, 2011
BILOG Antenna SCHWARZBECK	VULB9168	9168-160	Apr. 13, 2011	Apr. 12, 2012
HORN Antenna SCHWARZBECK	9120D	9120D-405	Feb. 08, 2011	Feb. 07, 2012
HORN Antenna SCHWARZBECK	BBHA 9170	BBHA9170243	Dec. 27, 2010	Dec. 26, 2011
Preamplifier Agilent	8447D	2944A10633	Nov. 02, 2010	Nov. 01, 2011
Preamplifier Agilent	8449B	3008A01964	Nov. 02, 2010	Nov. 01, 2011
RF signal cable HUBER+SUHNNER	SUCOFLEX 104	295014/4	Sep. 03, 2010	Sep. 02, 2011
RF signal cable HUBER+SUHNNER	SUCOFLEX 104	12738/6	Sep. 03, 2010	Sep. 02, 2011
Software ADT.	ADT_Radiated_ V7.6.15.9.2	NA	NA	NA
Antenna Tower inn-co GmbH	MA 4000	013303	NA	NA
Antenna Tower Controller inn-co GmbH	CO2000	017303	NA	NA
Turn Table ADT.	TT100.	TT93021703	NA	NA
Turn Table Controller ADT.	SC100.	SC93021703	NA	NA

- NOTE:**
1. The calibration interval of the above test instruments is 12 months and the calibrations are traceable to NML/ROC and NIST/USA.
 2. The test was performed in HwaYa Chamber 3.
 3. The horn antenna and HP preamplifier (model: 8449B) are used only for the measurement of emission frequency above 1GHz if tested.
 4. The FCC Site Registration No. is 988962.
 5. The IC Site Registration No. is IC 7450F-3.

4.1.3 TEST PROCEDURES

- a. The power was measured with R&S Spectrum Analyzer. All measurements were done at 3 channels 25, 600 and 1175 (low, middle and high operational frequency range.)
- b. The conducted peak output power used the power splitter via EUT RF power connector between simulation base station and spectrum analyzer. The path loss included the splitter loss, cable loss and 20dB pad loss. The spectrum set RB/VB 3MHz (CDMA) then read peak power value and record to the test. (All transmitted path loss shall be considered in the test report data.)
- c. Substitution method is used for E.I.R.P measurement. In the semi-anechoic chamber, EUT placed on the 0.8m height of Turn Table, rotated the table around 360 degrees to search the maximum radiation power and receiver antenna shall be rotated vertical and horizontal polarization and moved height from 1m to 4m to find the maximum polar radiated power. The " Read Value " is the spectrum reading the maximum power value.
- d. The substitution horn antenna is substituted for EUT at the same position and signals generator export the CW signal to the substitution antenna via a tx cable . Rotated the Turn Table and moved receiving antenna to find the maximum radiation power. Adjust output power level of S.G to get a Value of spectrum reading equal to " Read Value " of step c. Record the power level of S.G
- e. $EIRP = \text{Output power level of S.G} - \text{TX cable loss} + \text{Antenna gain of substitution horn.}$

4.1.4 TEST SETUP

EIRP POWER MEASUREMENT:

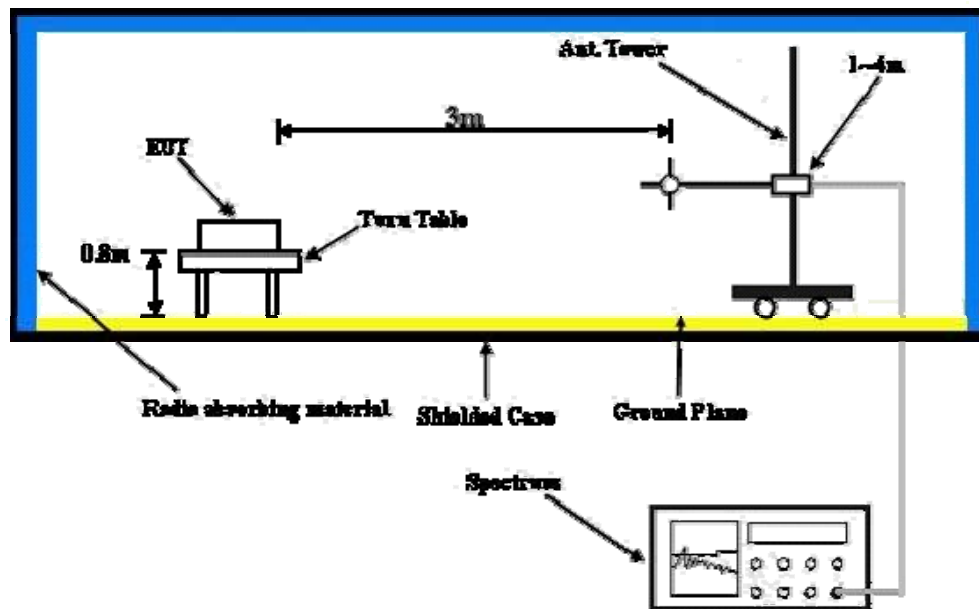

For the actual test configuration, please refer to the attached file (Test Setup Photo).

CONDUCTED POWER MEASUREMENT:

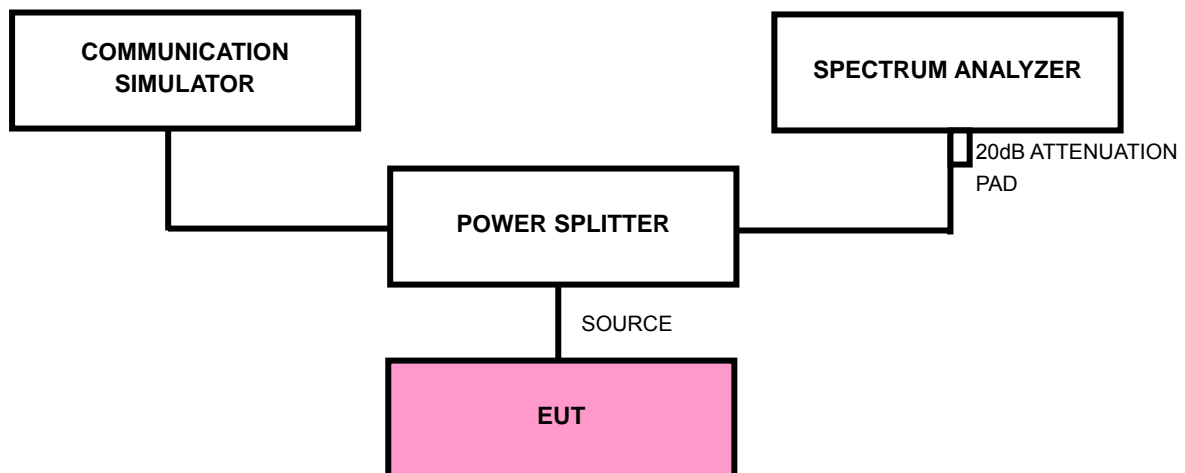

For the actual test configuration, please refer to the related item – Photographs of the Test Configuration.

4.1.5 EUT OPERATING CONDITIONS

- The EUT makes a call to the communication simulator.
- The communication simulator station system controlled an EUT to export maximum output power under transmission mode and specific channel frequency.

4.1.6 TEST RESULTS

TEST MODE A:

WORST CASE CONDUCTED POWER OF 1x EV-DO								
CHANNEL	FREQ. (MHz)	Revision A	Release 0	CORR. FACTOR (dB)	Revision A		Release 0	
		RAW VALUE (dBm)			OUTPUT POWER			
		dBm	Watt		dBm	Watt		
25	1851.25	18.54	18.65	4.80	23.34	0.2158	23.45	0.2213
600	1880.00	18.77	18.84	4.80	23.57	0.2275	23.64	0.2312
1175	1908.75	18.62	18.50	4.80	23.42	0.2198	23.30	0.2138

TEST MODE B:

CDMA 2000 CONDUCTED POWER													
CHAN.	FREQ. (MHz)	CDMA 2000	RAW VALUE (dBm)					CORR. FACTOR (dB)	OUTPUT POWER (dBm)				
		RC	SO2	SO55	TDSO SO32 (FCH)	TDSO SO32 (FCH+ SCH)	SO3		SO2	SO55	TDSO SO32 (FCH)	TDSO SO32 (FCH+ SCH)	SO3
		25	1851.25	RC1	18.77	18.75	-		-	18.70	4.80	23.57	23.55
		RC3	18.73	18.71	18.63	18.60	18.56	4.80	23.53	23.51	23.43	23.40	23.36
600	1880.00	RC1	18.95	18.92	-	-	18.87	4.80	23.75	23.72	-	-	23.67
		RC3	18.86	18.84	18.77	18.69	18.64	4.80	23.66	23.64	23.57	23.49	23.44
1175	1908.75	RC1	18.26	18.22	-	-	18.13	4.80	23.06	23.02	-	-	22.93
		RC3	18.16	18.13	18.07	18.04	18.00	4.80	22.96	22.93	22.87	22.84	22.80

REMARKS: 1. Peak Output Power (dBm) = Raw Value (dBm) + Correction Factor (dB).
 2. Correction Factor (dB) = Power Splitter Loss (dB) + Cable Loss (dB) + 20dB Pad.



TEST MODE A:

EIRP POWER (1x EV-DO)								
CHANNEL	FREQ. (MHz)	S.G. VALUE (dBm)		CORR. FACTOR (dB)	OUTPUT POWER			
		Revision A	Release 0		Revision A		Release 0	
					dBm	Watt	dBm	Watt
25	1851.25	15.3	15.7	8.4	23.7	0.2344	24.1	0.2570
60	1880.00	15.3	15.6	8.6	23.9	0.2455	24.2	0.2630
1175	1908.75	15.9	16.6	8.5	24.4	0.2754	25.1	0.3236

TEST MODE B:

EIRP POWER (SO55)					
CHANNEL NO.	FREQUENCY (MHz)	S.G. VALUE (dBm)	CORRECTION FACTOR (dB)	OUTPUT POWER	
				dBm	Watt
25	1851.25	15.8	8.4	24.2	0.2630
600	1880.00	15.9	8.6	24.5	0.2818
1175	1908.75	15.2	8.5	23.7	0.2344

- REMARKS:** 1. Peak Output Power (dBm) = S.G Value (dBm) + Correction Factor (dB).
 2. Correction Factor (dB) = Substitution Antenna Gain (dB) + Cable Loss (dB).



4.2 FREQUENCY STABILITY MEASUREMENT

4.2.1 LIMITS OF FREQUENCY STABILITY MEASUREMENT

According to the FCC part 24.235 shall be tested the frequency stability. The rule is defined that "The frequency stability shall be sufficient to ensure that the fundamental emission stays within the authorized frequency block." The frequency error rate is according to the JTC standard that the frequency error rate shall be accurate to within 2.5ppm of the received frequency from the base station. The test extreme voltage is according to the 2.1055(d)(1) Vary primary supply voltage from 85 to 115 percent of the nominal value for other than hand carried battery equipment and the extreme temperature rule is comply with the 2.1055(a)(1) $-30 \sim 50$.

4.2.2 TEST INSTRUMENTS

DESCRIPTION & MANUFACTURER	MODEL NO.	SERIAL NO.	CALIBRATED UNTIL	CALIBRATED UNTIL
Spectrum Analyzer Agilent	E4446A	MY48250266	Aug. 11, 2010	Aug. 10, 2011
Hewlett Packard RF cable	8120-6192	01428251	NA	NA
RF cable	SUCOFLEX 104	257029	Sep. 11, 2010	Sep. 10, 2011
WIT Standard Temperature & Humidity Chamber	MHU-225AU	920842	Jun. 15, 2011	Jun. 14, 2012

NOTE: The calibration interval of the above test instruments is 12 months. And the calibrations are traceable to NML/ROC and NIST/USA.

4.2.3 TEST PROCEDURE

- a. Because of the measure the carrier frequency under the condition of the AFC lock, it shall be used the mobile station in the CDMA link mode. This is accomplished with the use of the communication simulator station. The oven room could control the temperatures and humidity. The CDMA link channel is the 600.
- b. Power must be removed when changing from one temperature to another or one voltage to another voltage. Power warm up is at least 15 min and power applied should perform before recording frequency error.
- c. EUT is connected the external power supply to control the DC input power. The various Volts from the minimum 3.6Volts to 4.2Volts. Each step shall be record the frequency error rate.
- d. The temperature range step is 10 degrees in this test items. All temperature levels shall be hold the ± 0.5 during the measurement testing.
- e. The each temperature step shall be at least 0.5 hours, consider the EUT could be test under the stability condition.

NOTE: The frequency error was recorded frequency error from the GSM simulator.

4.2.4 TEST SETUP

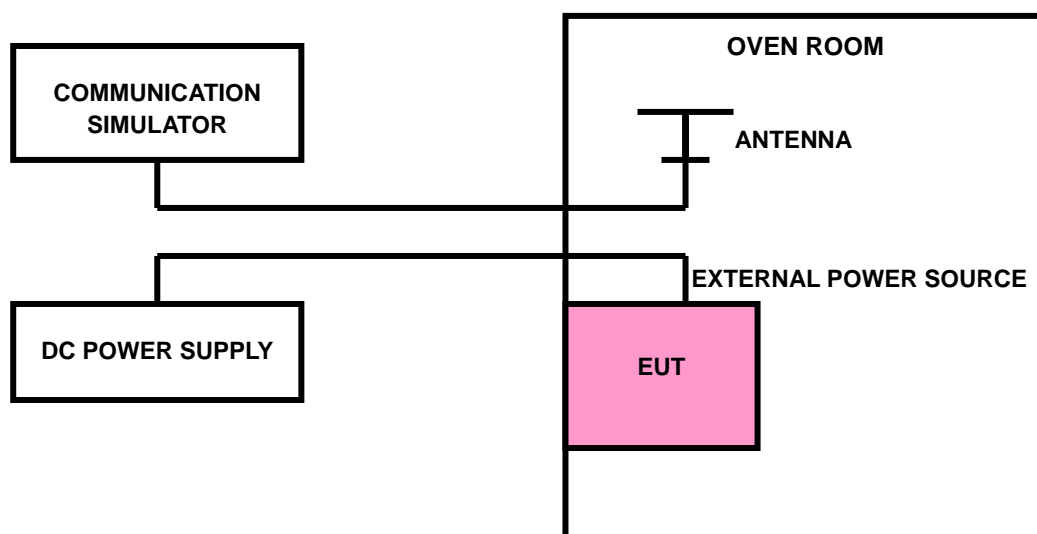



4.2.5 TEST RESULTS

TEST MODE A:

AFC FREQUENCY ERROR vs. VOLTAGE			
VOLTAGE (Volts)	FREQUENCY ERROR (Hz)	FREQUENCY ERROR (ppm)	LIMIT (ppm)
4.2	7	0.004	2.5
3.6	6	0.003	2.5

NOTE: The applicant defined the normal working voltage of the battery is from 3.6Vdc to 4.2Vdc.

AFC FREQUENCY ERROR vs. TEMP.			
TEMP. ()	FREQUENCY ERROR (Hz)	FREQUENCY ERROR (ppm)	LIMIT (ppm)
50	8	0.004	2.5
40	9	0.005	2.5
30	8	0.004	2.5
20	6	0.003	2.5
10	9	0.005	2.5
0	7	0.004	2.5
-10	8	0.004	2.5
-20	6	0.003	2.5
-30	8	0.004	2.5

TEST MODE B:

AFC FREQUENCY ERROR vs. VOLTAGE			
VOLTAGE (Volts)	FREQUENCY ERROR (Hz)	FREQUENCY ERROR (ppm)	LIMIT (ppm)
4.2	10	0.005	2.5
3.6	11	0.006	2.5

NOTE: The applicant defined the normal working voltage of the battery is from 3.6Vdc to 4.2Vdc.

AFC FREQUENCY ERROR vs. TEMP.			
TEMP. ()	FREQUENCY ERROR (Hz)	FREQUENCY ERROR (ppm)	LIMIT (ppm)
50	9	0.005	2.5
40	11	0.006	2.5
30	10	0.005	2.5
20	9	0.005	2.5
10	8	0.004	2.5
0	12	0.006	2.5
-10	11	0.006	2.5
-20	10	0.005	2.5
-30	13	0.007	2.5

4.3 OCCUPIED BANDWIDTH MEASUREMENT

4.3.1 LIMITS OF OCCUPIED BANDWIDTH MEASUREMENT

According to FCC 24.238(b) specified that emission bandwidth is defined as the width of the signal between two points, one below the carrier center frequency and one above the carrier center frequency, outside of which all emissions are attenuated at least 26 dB below the transmitter power.

4.3.2 TEST INSTRUMENTS

DESCRIPTION & MANUFACTURER	MODEL NO.	SERIAL NO.	DATE OF CALIBRATION	DUE DATE OF CALIBRATION
ROHDE & SCHWARZ Spectrum Analyzer	FSP40	100039	Feb. 23, 2011	Feb. 22, 2012
Mini-Circuits Power Splitter	ZN2PD-9G	NA	May 26, 2011	May 25, 2012
RF cable	SUCOFLEX 104	274403/4	Aug. 20, 2010	Aug. 19, 2011
RF cable	SUCOFLEX 104	250729/4	Aug. 19, 2010	Aug. 18, 2011
RF cable	SUCOFLEX 104	214377/4	Aug. 19, 2010	Aug. 18, 2011
JFW 20dB attenuation	50HF-020-SMA	NA	NA	NA

NOTE: The calibration interval of the above test instruments is 12 months. And the calibrations are traceable to NML/ROC and NIST/USA.

4.3.3 TEST SETUP

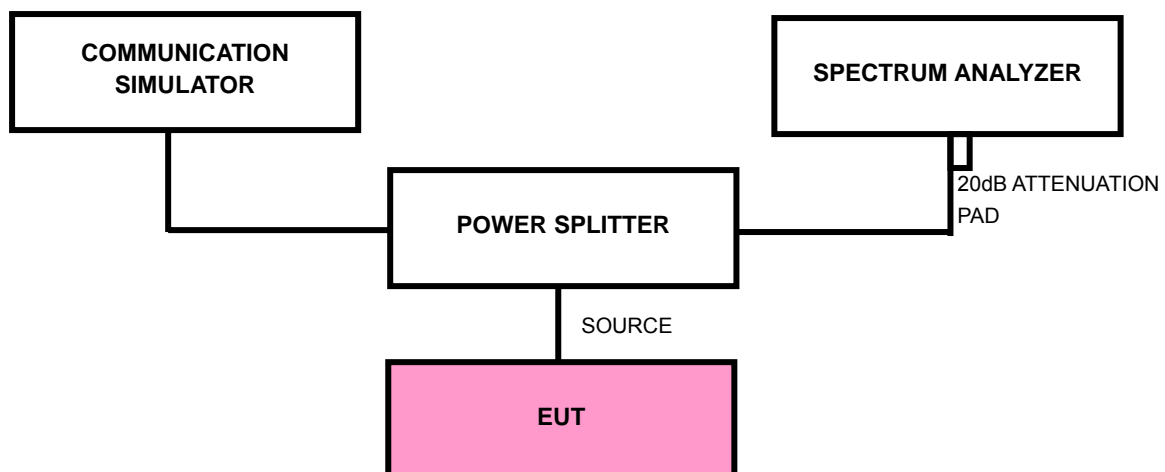



4.3.4 TEST PROCEDURES

- a. The EUT makes a call to the communication simulator. The power was measured with R&S Spectrum Analyzer. All measurements were done at 3 channels 25, 600 and 1175 (low, middle and high operational frequency range.)
- b. The conducted occupied bandwidth used the power splitter via EUT RF power connector between simulation base station and spectrum analyzer.
- c. The communication simulator station system controlled a EUT to export maximum output power under transmission mode and specific channel frequency. Use OBW measurement function of Spectrum analyzer to measure 99 % occupied bandwidth.

4.3.5 EUT OPERATING CONDITION

- a. The EUT makes a call to the communication simulator.
- b. The communication simulator station system controlled a EUT to export maximum and minimum output power under transmission mode and specific channel frequency.

4.3.6 TEST RESULTS

TEST MODE A:

EV-DO Rev. 0:

CHANNEL	FREQUENCY (MHz)	99% OCCUPIED BANDWIDTH (MHz)
25	1851.25	1.28
600	1880.00	1.28
1175	1908.75	1.28

CH 25

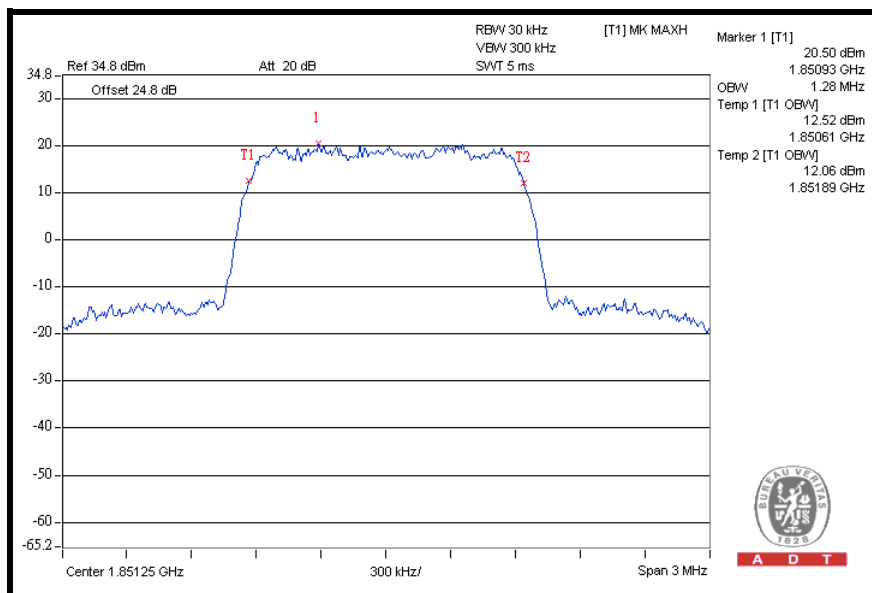

FOR EV-DO Rev. A:

CHANNEL	FREQUENCY (MHz)	99% OCCUPIED BANDWIDTH (MHz)
25	1851.25	1.28
600	1880.00	1.28
1175	1908.75	1.28

CH 25

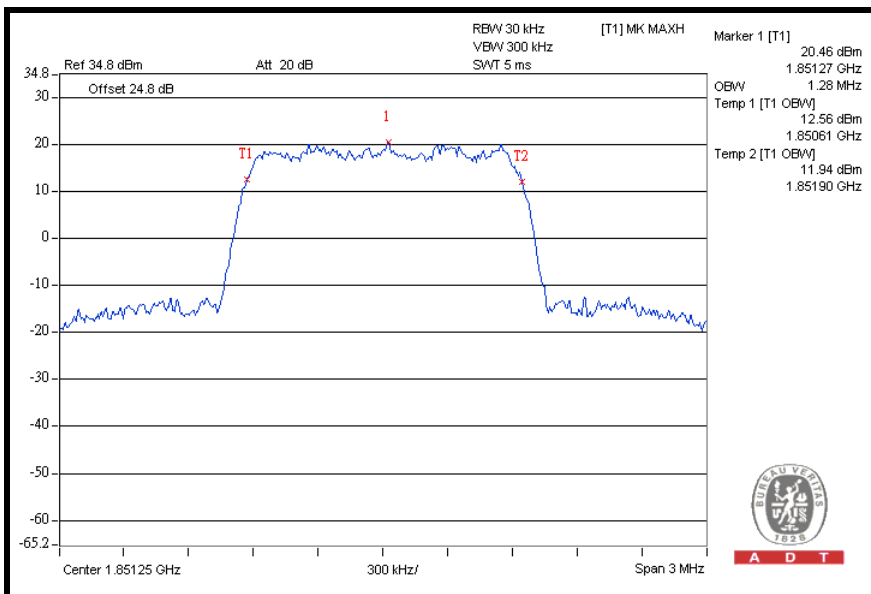



A D T

TEST MODE B:

CHANNEL	FREQUENCY (MHz)	99% OCCUPIED BANDWIDTH (MHz)
25	1851.25	1.28
600	1880.00	1.28
1175	1908.75	1.28

CH 25

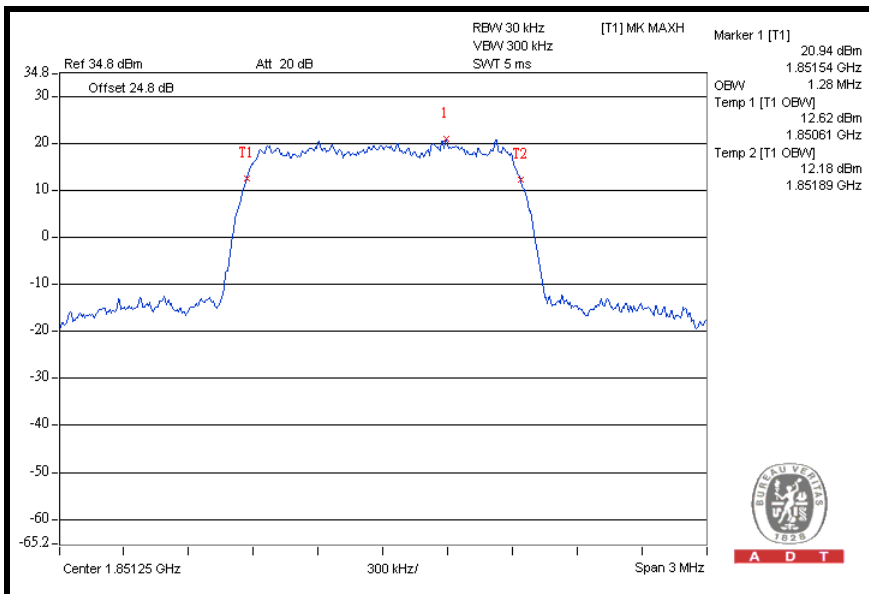

A D T

4.4 BAND EDGE MEASUREMENT

4.4.1 LIMITS OF BAND EDGE MEASUREMENT

According to FCC 24.238(a) specified that power of any emission outside of the authorized operating frequency ranges must be attenuated below the transmitting power (P) by a factor of at least $43 + 10 \log(P)$ dB. In the 1 MHz bands immediately outside and adjacent to the frequency block a resolution bandwidth of at least one percent of the emission bandwidth of the fundamental emission of the transmitter may be employed.

4.4.2 TEST INSTRUMENTS

DESCRIPTION & MANUFACTURER	MODEL NO.	SERIAL NO.	DATE OF CALIBRATION	DUE DATE OF CALIBRATION
ROHDE & SCHWARZ Spectrum Analyzer	FSP40	100039	Feb. 23, 2011	Feb. 22, 2012
Mini-Circuits Power Splitter	ZN2PD-9G	NA	May 26, 2011	May 25, 2012
RF cable	SUCOFLEX 104	274403/4	Aug. 20, 2010	Aug. 19, 2011
RF cable	SUCOFLEX 104	250729/4	Aug. 19, 2010	Aug. 18, 2011
RF cable	SUCOFLEX 104	214377/4	Aug. 19, 2010	Aug. 18, 2011
JFW 20dB attenuation	50HF-020-SMA	NA	NA	NA

NOTE: The calibration interval of the above test instruments is 12 months. And the calibrations are traceable to NML/ROC and NIST/USA.

4.4.3 TEST SETUP

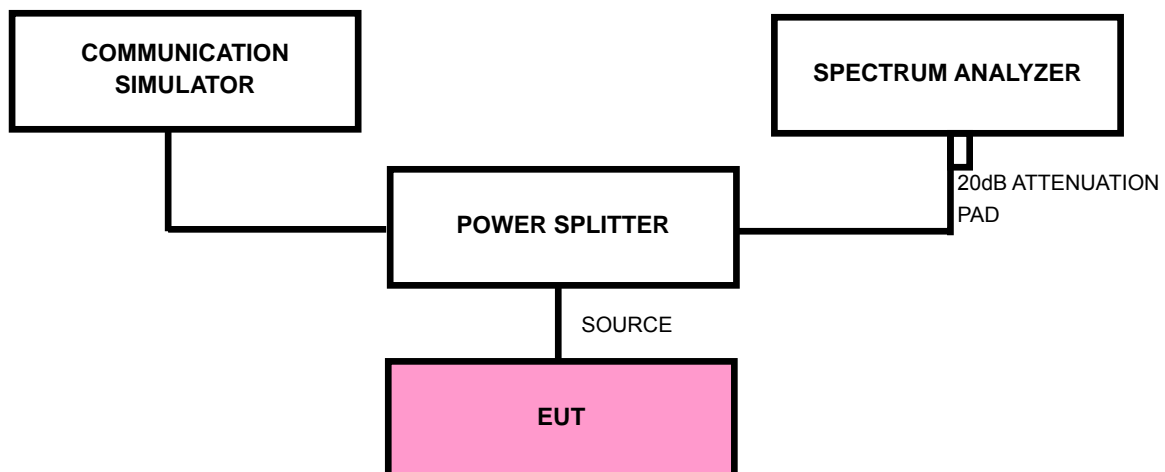



4.4.4 TEST PROCEDURES

- a. The EUT makes a call to the communication simulator. The power was measured with R&S Spectrum Analyzer. All measurements were done at 2 channels 25 and 1175 (CDMA) (low and high operational frequency range.)
- b. The band edge measurement used the power splitter via EUT RF power connector between simulation base station and spectrum analyzer.
- c. The center frequency of spectrum is the band edge frequency and span is 3 MHz. RB of the spectrum is 15kHz and VB of the spectrum is 15kHz.
- d. Record the max trace plot into the test report.

4.4.5 EUT OPERATING CONDITION

- a. The EUT makes a call to the communication simulator.
- b. The communication simulator station system controlled an EUT to export maximum output power under transmission mode and specific channel frequency.



A D T

4.4.6 TEST RESULTS

TEST MODE A:

FOR EV-DO Rev. 0:

LOWER BAND EDGE

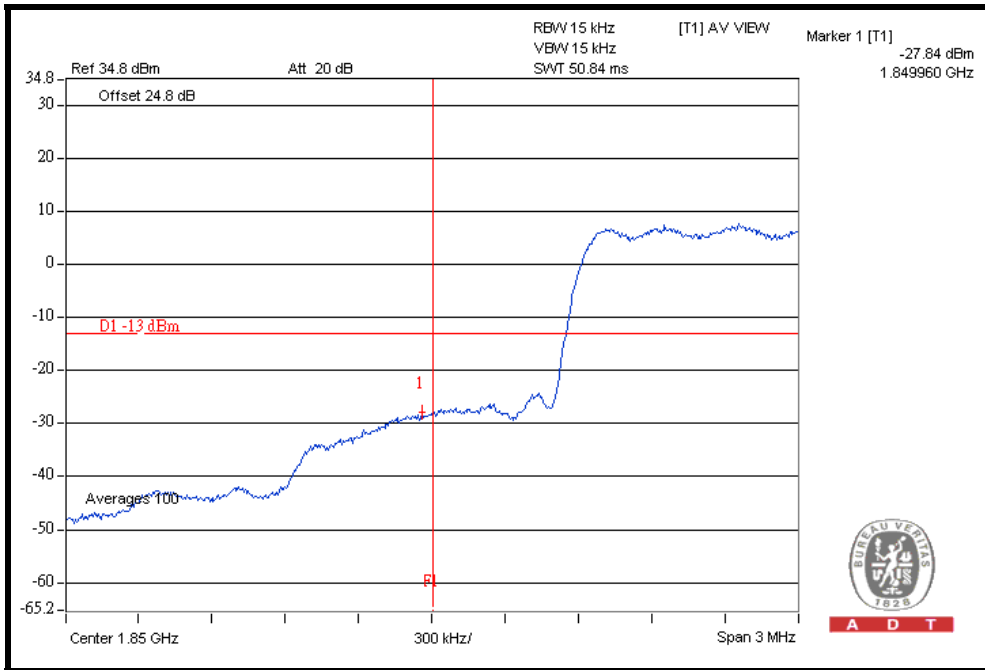

HIGHER BAND EDGE

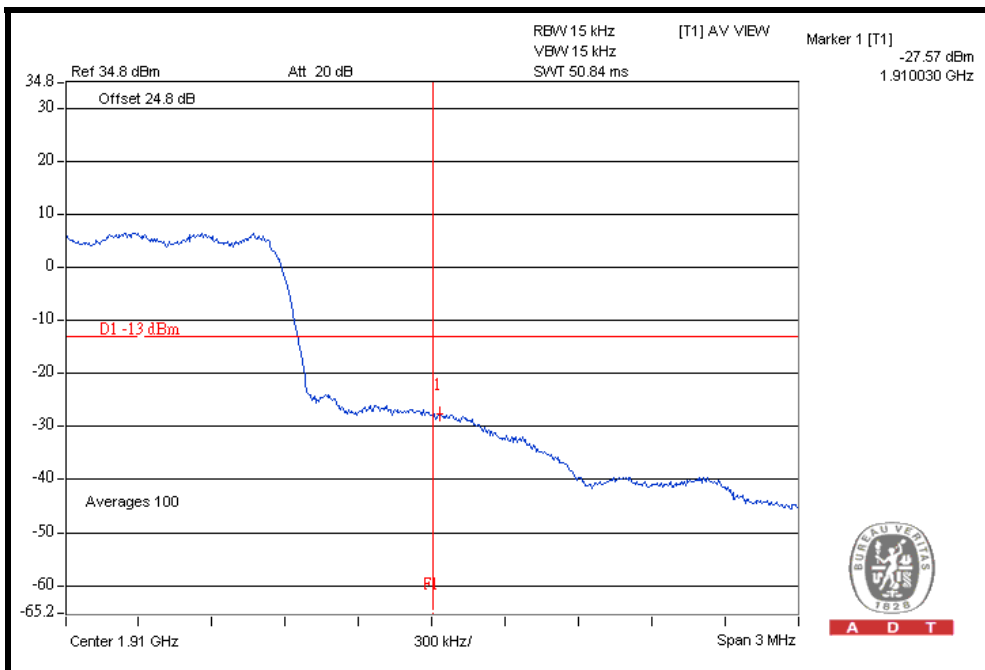



A D T

FOR EV-DO Rev. A: LOWER BAND EDGE

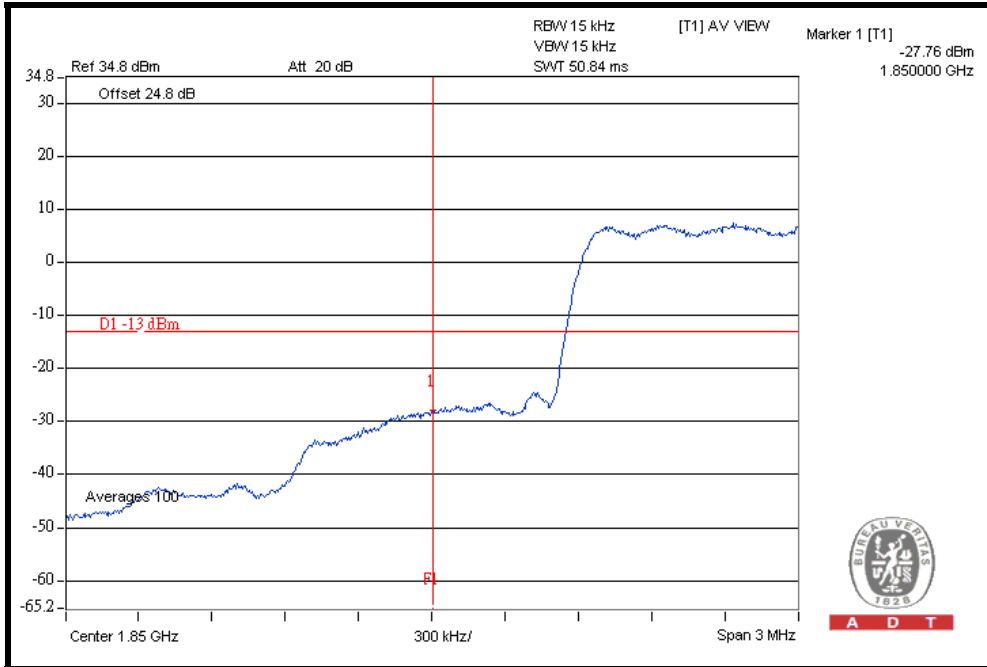

HIGHER BAND EDGE

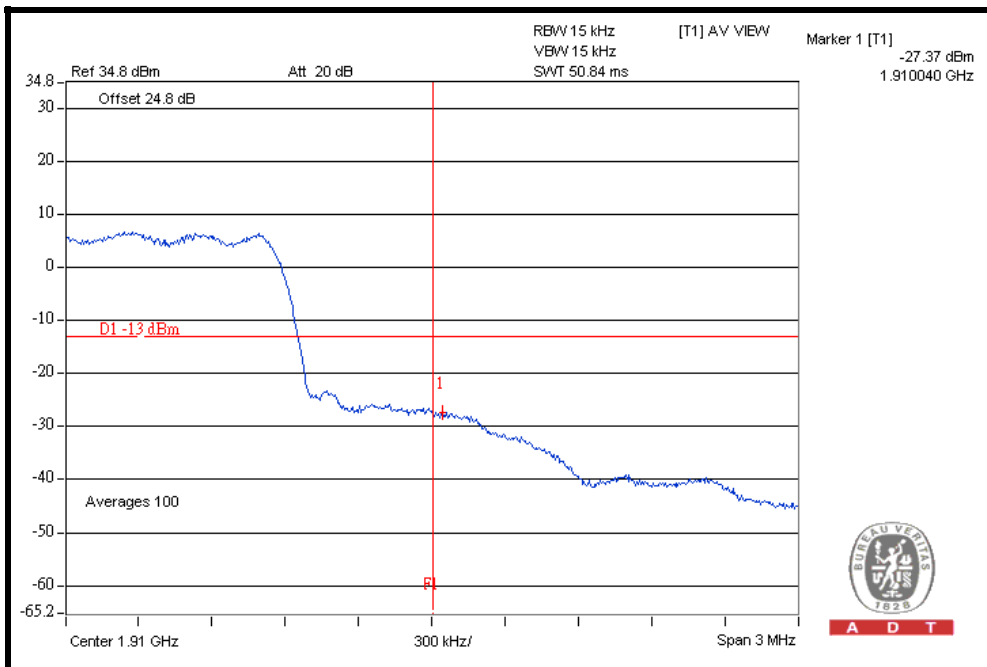



A D T

TEST MODE B: LOWER BAND EDGE

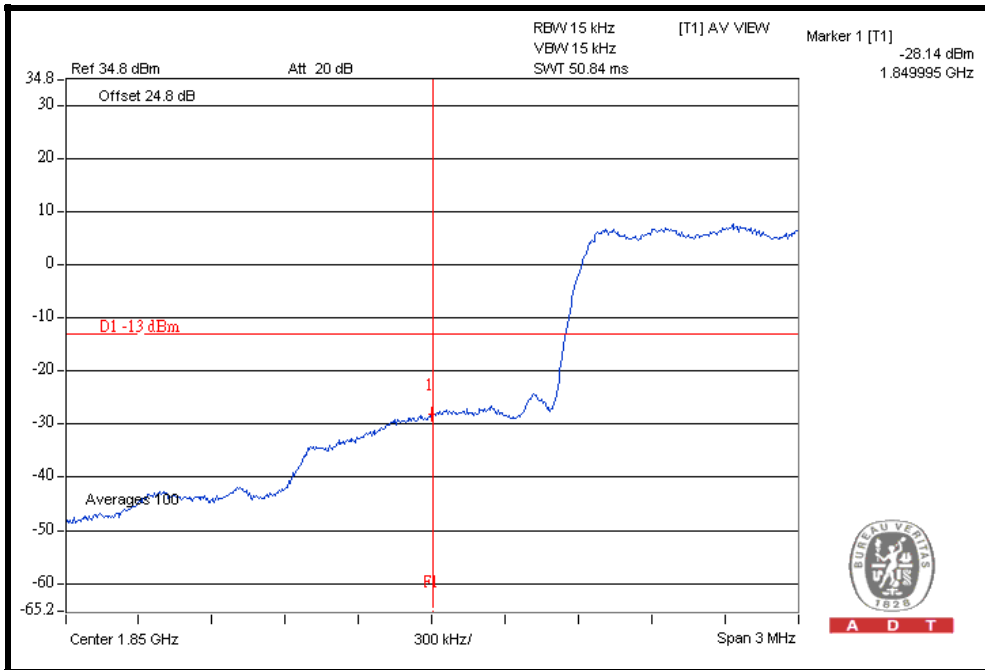

HIGHER BAND EDGE

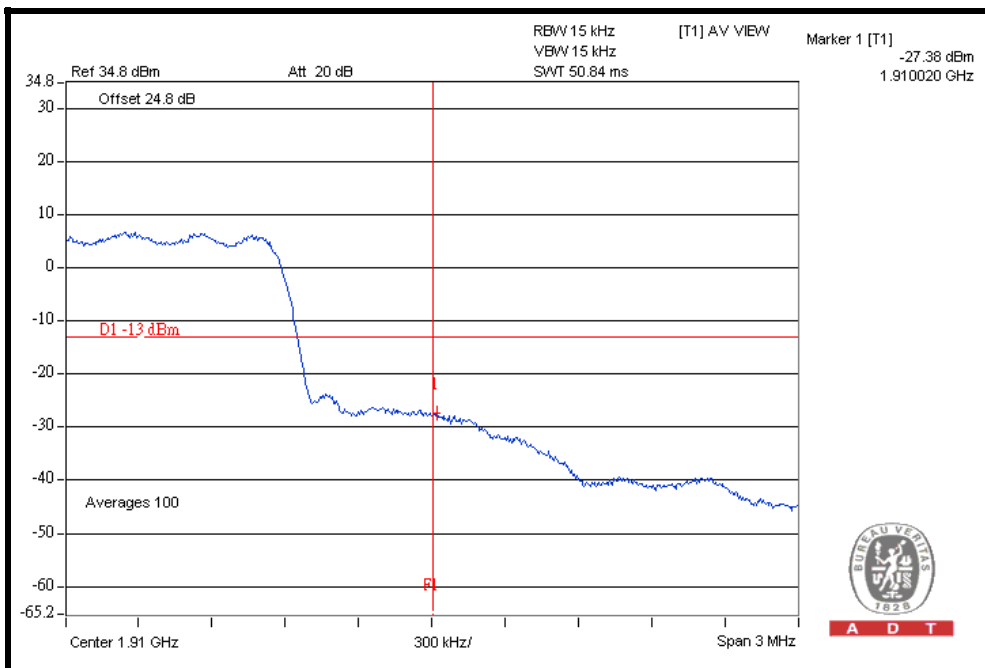



4.5 CONDUCTED SPURIOUS EMISSIONS

4.5.1 LIMITS OF CONDUCTED SPURIOUS EMISSIONS MEASUREMENT

In the FCC 24.238(a), On any frequency outside a licensee's frequency block within USPCS spectrum, the power of any emission shall be attenuated below the transmitter power (P) by at least $43 + 10 \log (P)$ dB. The specified minimum attenuation becomes 43dB and the limit of emission equal to -13dBm .

4.5.2 TEST INSTRUMENTS

DESCRIPTION & MANUFACTURER	MODEL NO.	SERIAL NO.	DATE OF CALIBRATION	DUE DATE OF CALIBRATION
ROHDE & SCHWARZ Spectrum Analyzer	FSP40	100039	Feb. 23, 2011	Feb. 22, 2012
Wainwright Instruments Band Reject Filter	WRCG 824/849-810/ 863-60/9SS	SN1	Mar. 24, 2011	Mar. 23, 2012
WI Highpass filter	WHK1.5/15G-10ST	SN1	Mar. 29, 2011	Mar. 28, 2012
Mini-Circuits Power Splitter	ZN2PD-9G	NA	May 26, 2011	May 25, 2012
RF cable	SUCOFLEX 104	274403/4	Aug. 20, 2010	Aug. 19, 2011
RF cable	SUCOFLEX 104	250729/4	Aug. 19, 2010	Aug. 18, 2011
RF cable	SUCOFLEX 104	214377/4	Aug. 19, 2010	Aug. 18, 2011
JFW 20dB attenuation	50HF-020-SMA	NA	NA	NA

NOTE: The calibration interval of the above test instruments is 12 months. And the calibrations are traceable to NML/ROC and NIST/USA.

4.5.3 TEST PROCEDURE

- a. The EUT makes a phone call to the communication simulator. The power was measured with R&S Spectrum Analyzer. All measurements were done at 3 channels 25, 600 and 1175 (low, middle and high operational frequency range.)
- b. The conducted spurious emission used the power splitter via EUT RF power connector between simulation base station and spectrum analyzer.
- c. When the spectrum scanned from 9 kHz to 3GHz, it shall be connected to the band reject filter attenuated the carried frequency. The spectrum set RB=1MHz, VB=3MHz.
- d. When the spectrum scanned from 3 kHz to 20GHz, it shall be connected to the high pass filter attenuated the carried frequency. The spectrum set RB=1MHz, VB=3MHz.

4.5.4 TEST SETUP

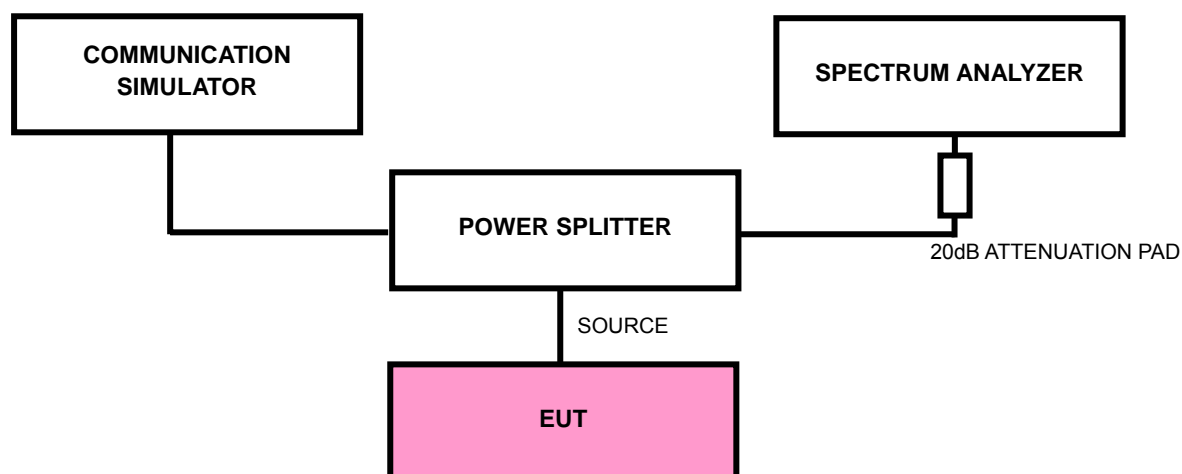

4.5.5 EUT OPERATING CONDITIONS

- a. The EUT makes a phone call to the communication simulator.
- b. The communication simulator station system controlled an EUT to export maximum output power under transmission mode and specific channel frequency.



A D T

4.5.6 TEST RESULTS

**TEST MODE A:
FOR EV-DO Rev. 0:**

CH 25: 9kHz ~ 3GHz

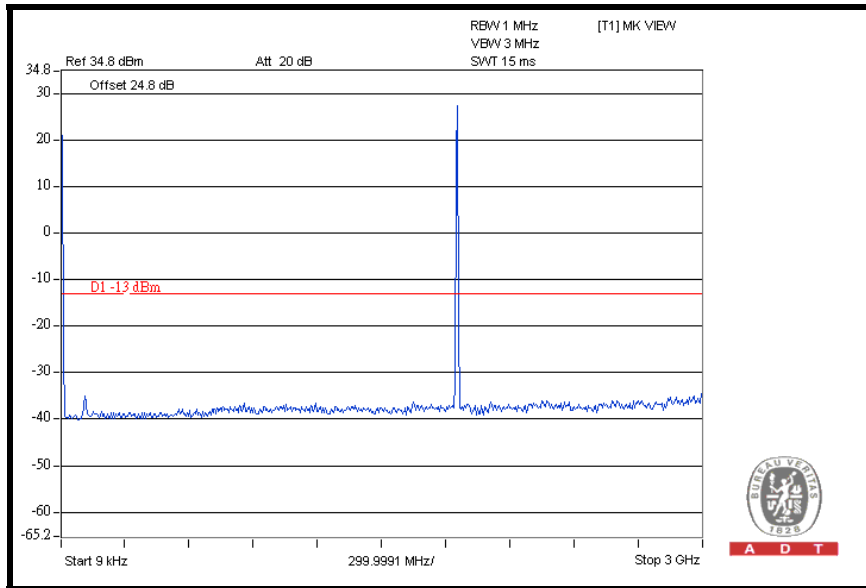

3GHz ~ 10GHz

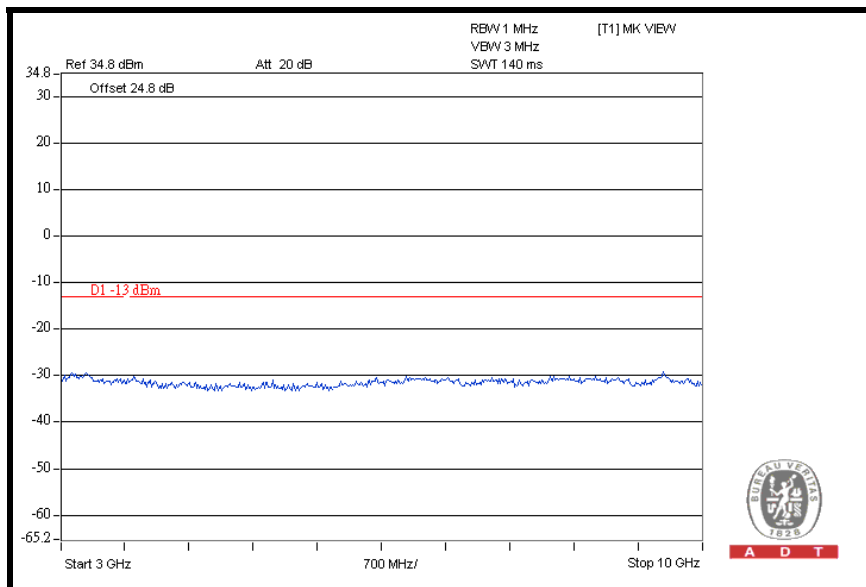



A D T

10GHz ~ 20GHz

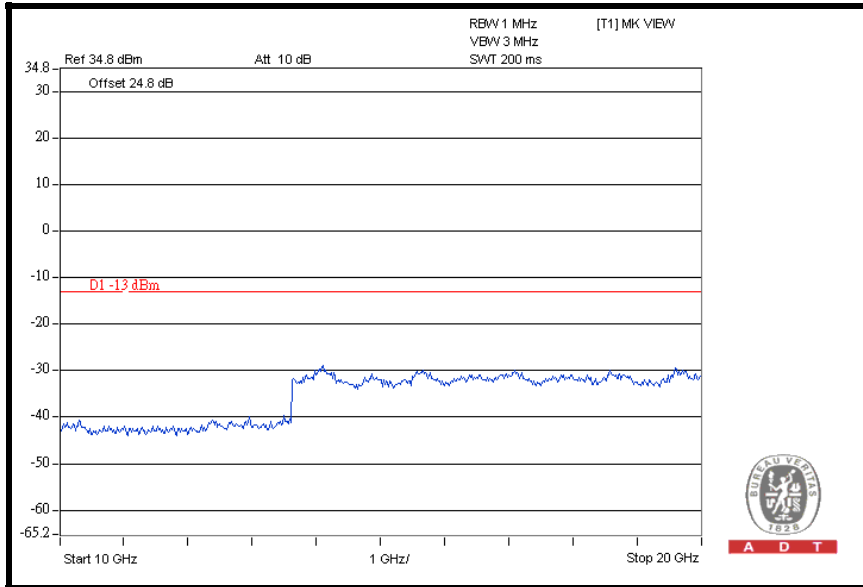

CH 600: 9kHz ~ 3GHz

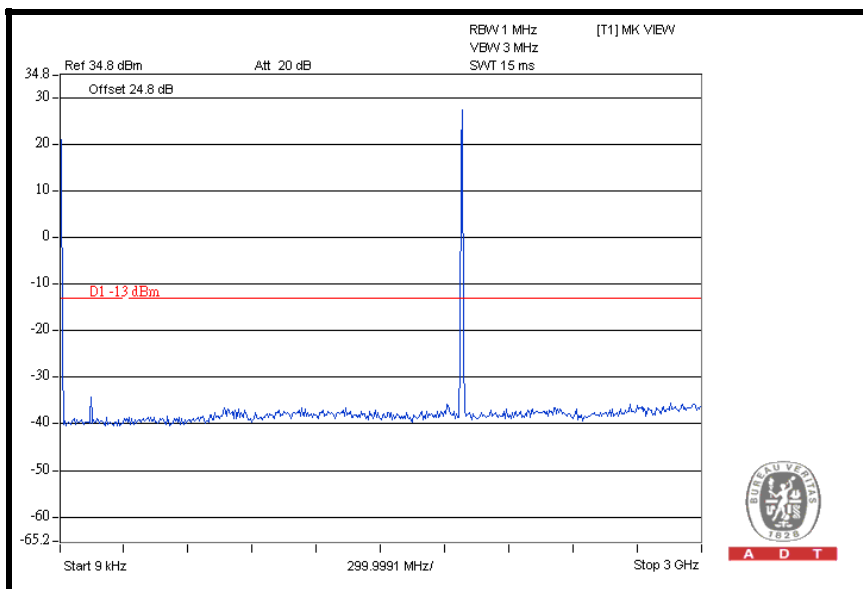



A D T

3GHz ~ 10GHz

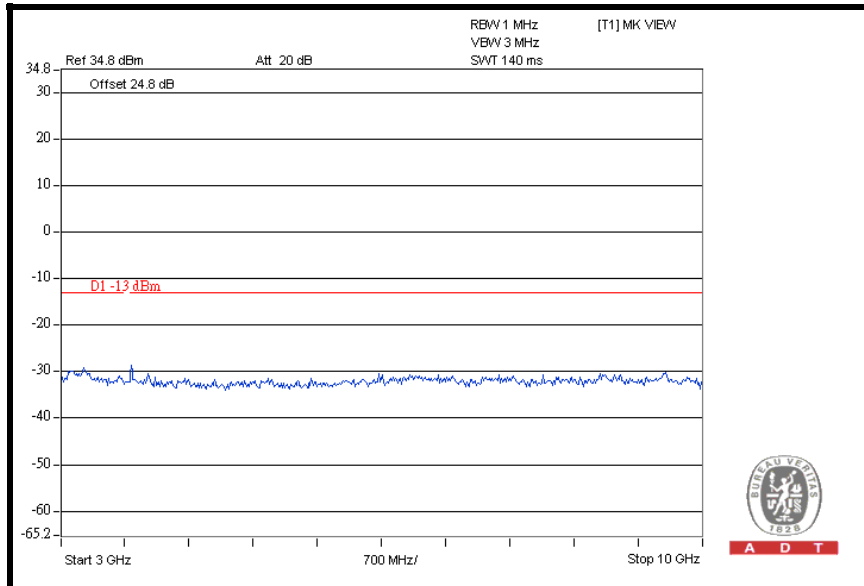

10GHz ~ 20GHz

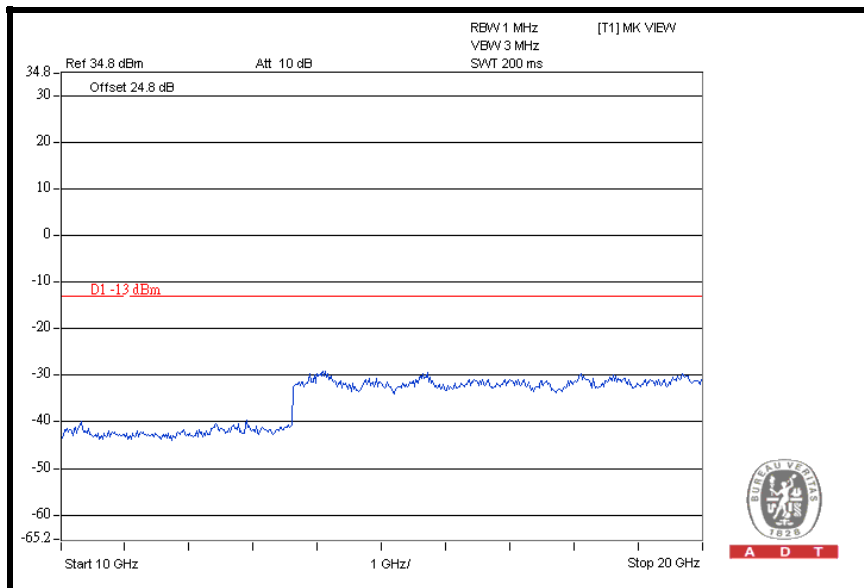



A D T

CH 1175: 9kHz ~ 3GHz

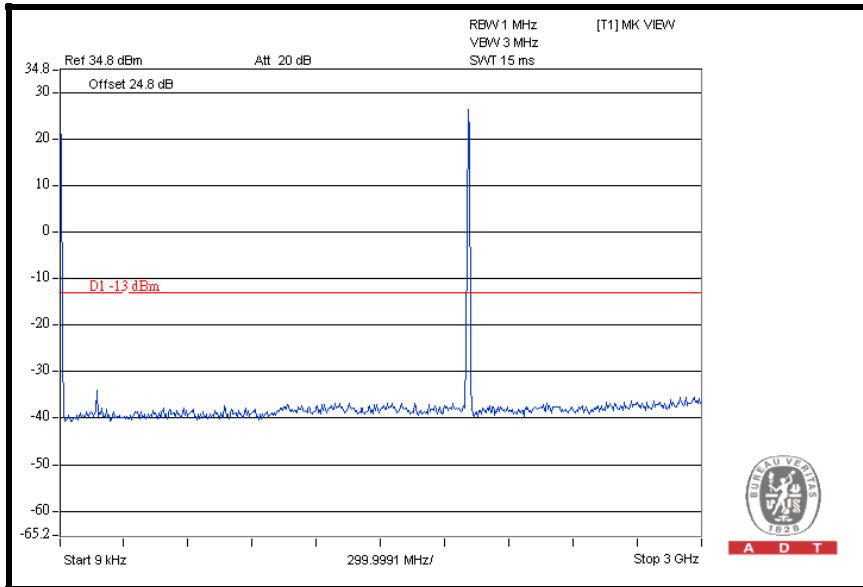

3GHz ~ 10GHz

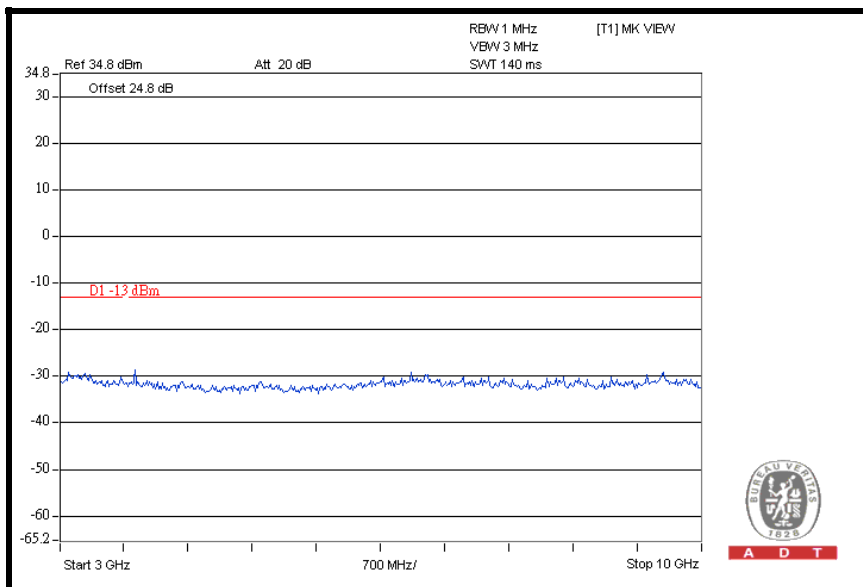



A D T

10GHz ~ 20GHz

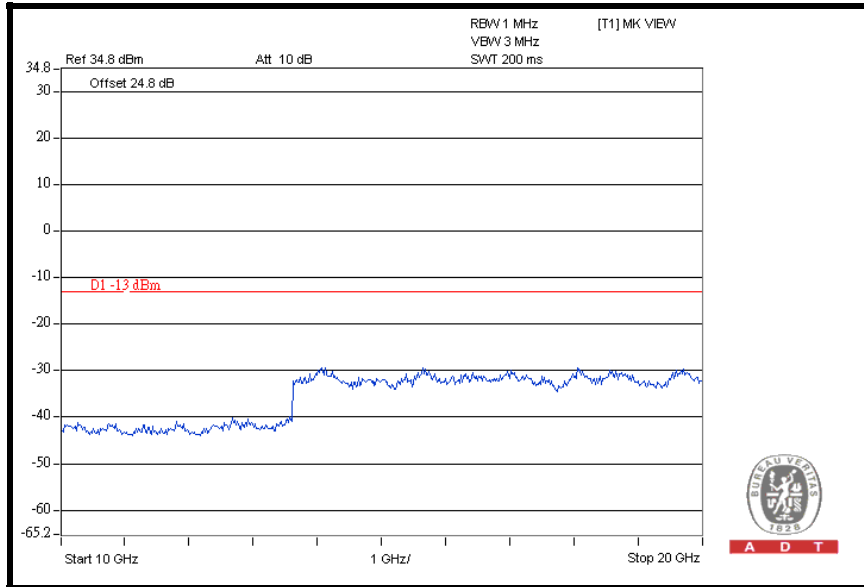



A D T

TEST MODE B:

CH 25: 9kHz ~ 3GHz

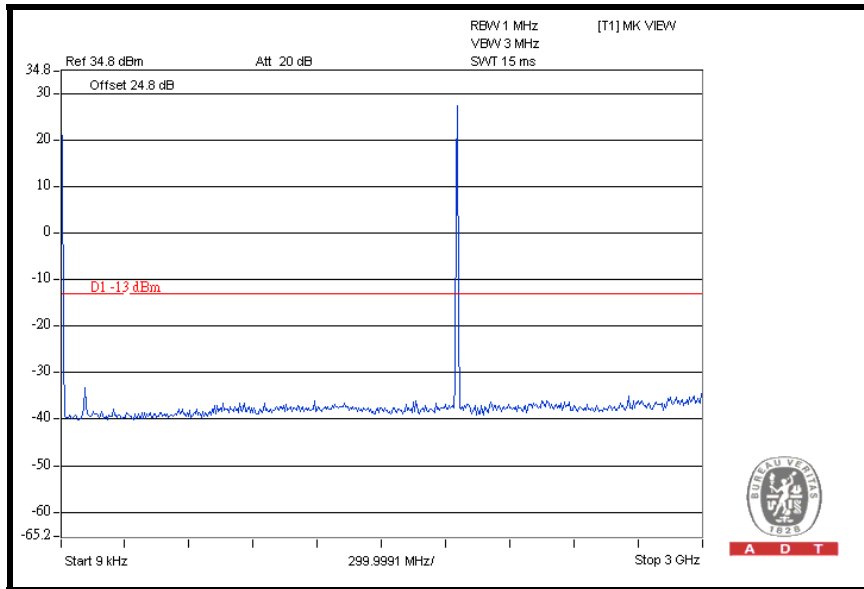

3GHz ~ 10GHz

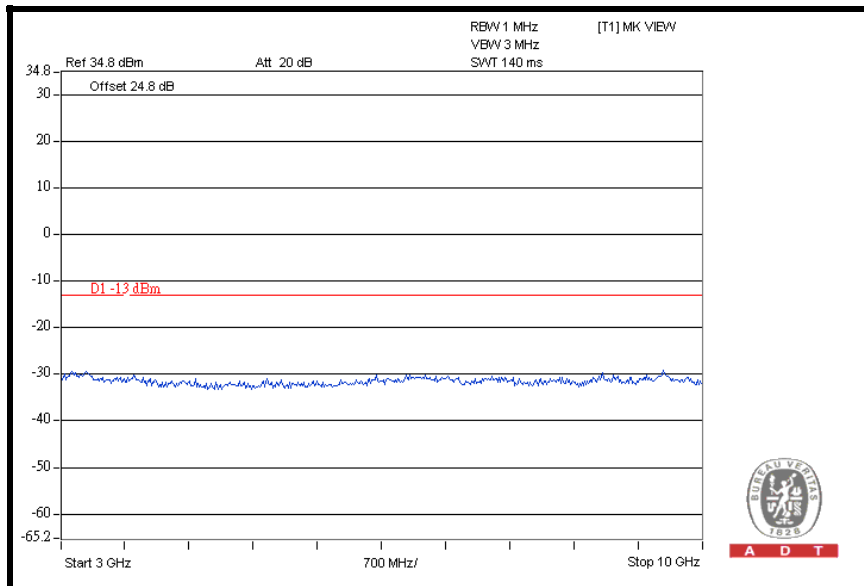



A D T

10GHz ~ 20GHz

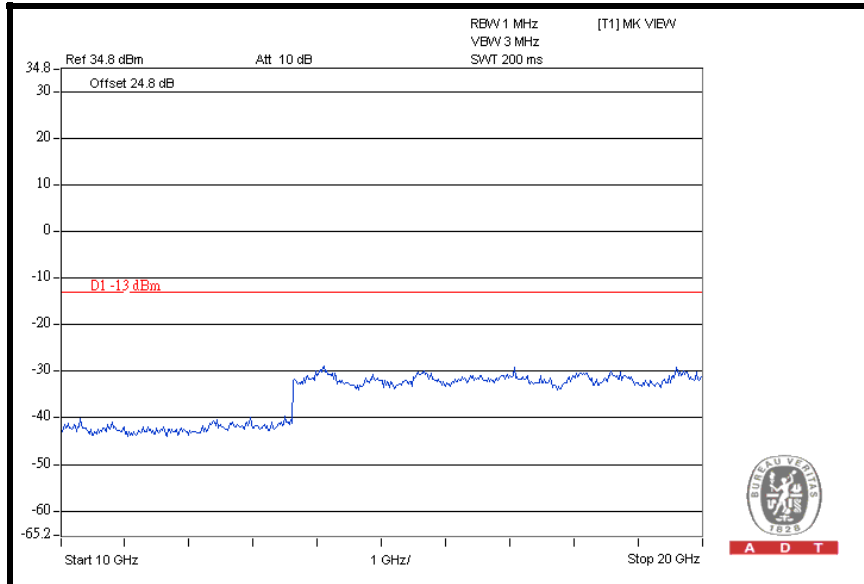

CH 600: 9kHz ~ 3GHz

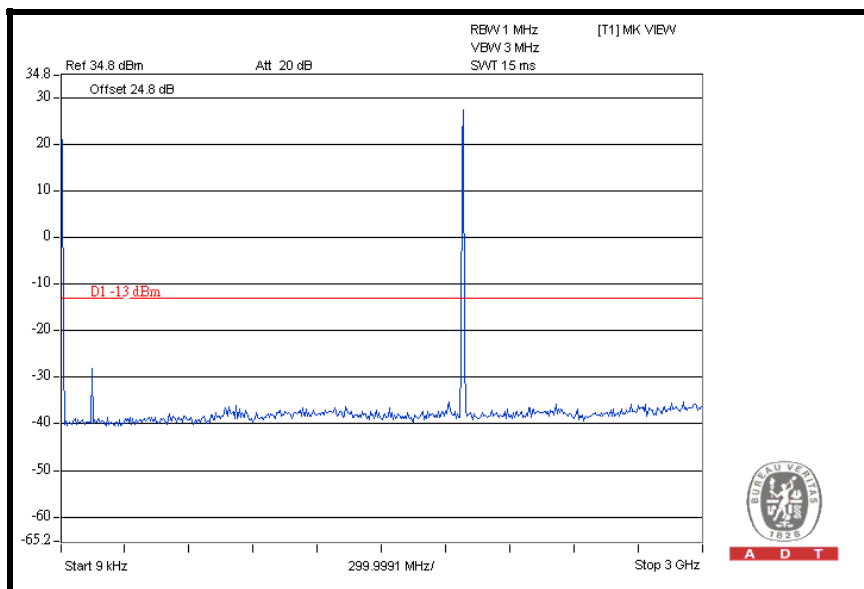



A D T

3GHz ~ 10GHz

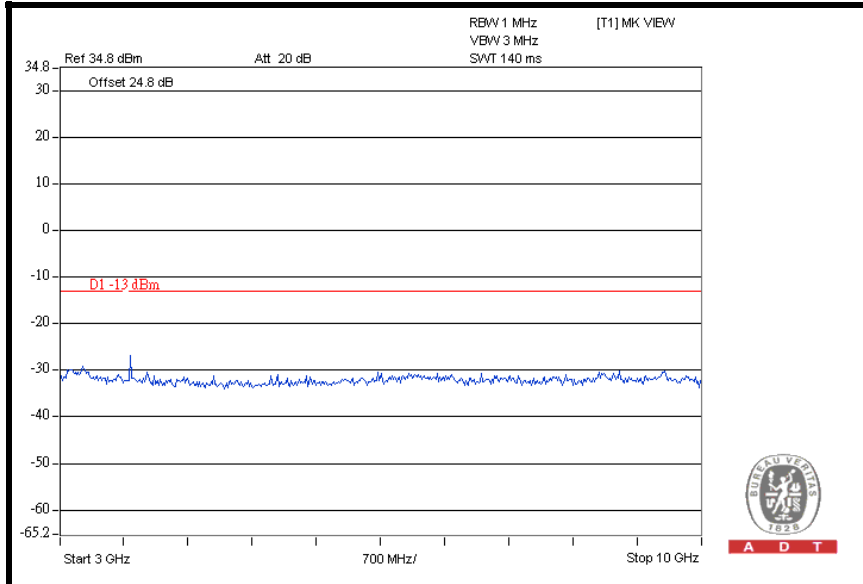

10GHz ~ 20GHz

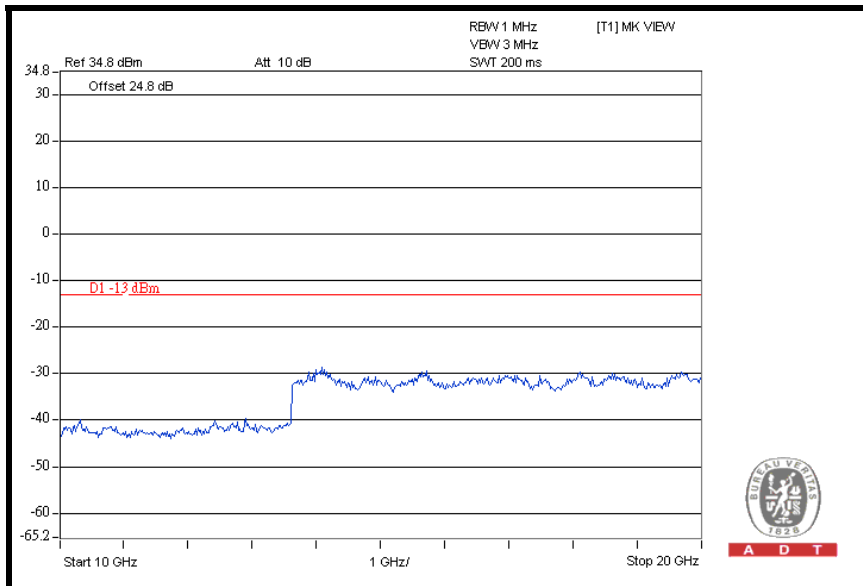



A D T

CH 1175: 9kHz ~ 3GHz

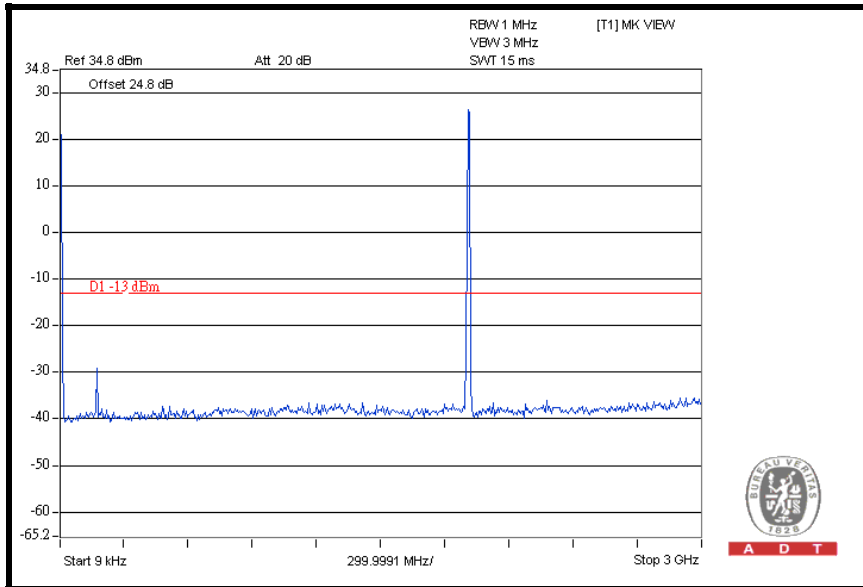

3GHz ~ 10GHz

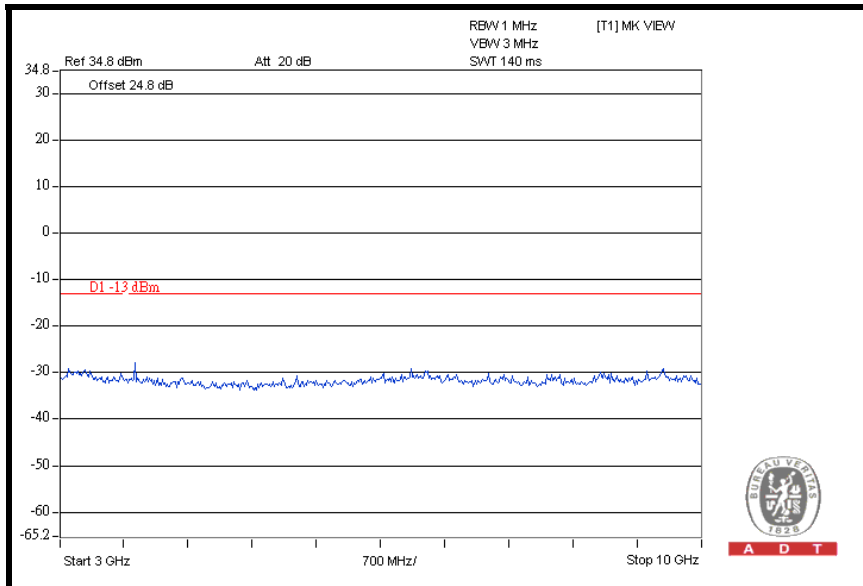



A D T

10GHz ~ 20GHz

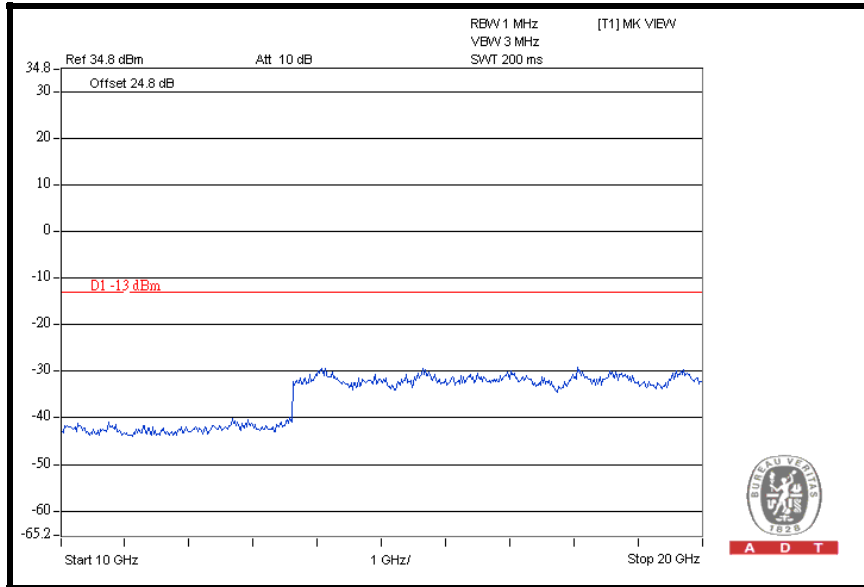



4.6 RADIATED EMISSION MEASUREMENT (BELOW 1GHz)

4.6.1 LIMITS OF RADIATED EMISSION MEASUREMENT

In the FCC 24.238(a), On any frequency outside a licensee's frequency block within USPCS spectrum, the power of any emission shall be attenuated below the transmitter power (P) by at least $43 + 10 \log (P)$ dB. The emission of limit equal to -13 dBm. So the limit of emission is the same absolute specified line.

LIMIT (dBm)	EQUIVALENT FIELD STRENGTH AT 3m (dBuV/m) (NOTE)
-13	82.2

NOTE: The following formula is used to convert the equipment radiated power to field strength.

$$E = [1000000\sqrt{(30P)}] / 3 \text{ uV/m, where P is Watts.}$$

4.6.2 TEST INSTRUMENTS

Same as 4.1.2.

4.6.3 TEST PROCEDURES

- a. The EUT was placed on the top of a rotating table 0.8 meters above the ground at a 3 meters semi-anechoic chamber. The table was rotated 360 degrees to determine the position of the highest radiation.
- b. The EUT was set 3 meters away from the interference-receiving antenna, which was mounted on the top of a variable-height antenna tower.
- c. The antenna is a broadband antenna, and its height is varied from one meter to four meters above the ground to determine the maximum value of the field strength. Both horizontal and vertical polarizations of the antenna are set to make the measurement.
- d. For each suspected emission, the EUT was arranged to its worst case and then the antenna was tuned to heights from 1 meter to 4 meters and the rotatable table was turned from 0 degrees to 360 degrees to find the maximum reading.
- e. The test-receiver system was set to Peak Detect Function and Specified Bandwidth with Maximum Hold Mode.
- f. If the emission level of the EUT in peak mode was lower than the limit specified, then testing could be stopped and the peak values of the EUT would be reported. Otherwise the emissions would be re-tested one by one using peak, quasi-peak or average method as specified and then reported in a data sheet.

NOTE: The resolution bandwidth of spectrum analyzer is 1 MHz and the video bandwidth is 3 MHz.

4.6.4 DEVIATION FROM TEST STANDARD

No deviation

4.6.5 TEST SETUP

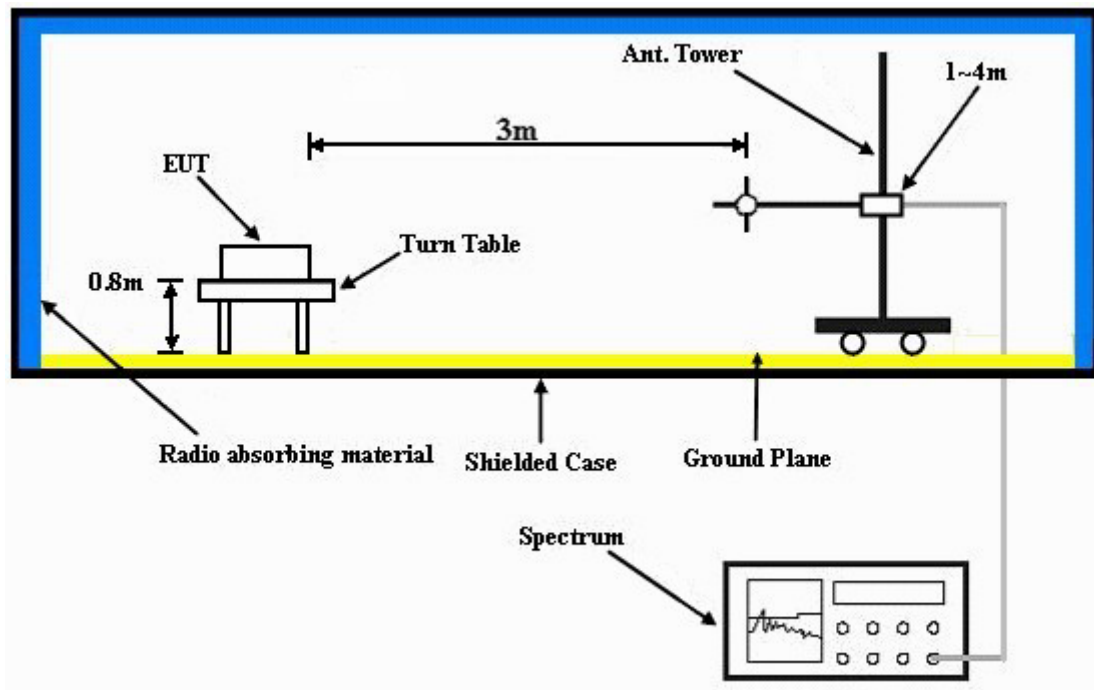

For the actual test configuration, please refer to the attached file (Test Setup Photo).

4.6.6 EUT OPERATING CONDITIONS

- a. The EUT makes a call to the communication simulator.
- b. The communication simulator station system controlled an EUT to export maximum output power under transmission mode and specific channel frequency.



4.6.7 TEST RESULTS

MODE	TX channel 1175	FREQUENCY RANGE	Below 1000MHz
ENVIRONMENTAL CONDITIONS	25deg. C, 65%RH	INPUT POWER	120Vac, 60 Hz
TEST MODE	A	TESTED BY	David Huang

ANTENNA POLARITY & TEST DISTANCE: HORIZONTAL AT 3 M								
No.	Freq. (MHz)	Emission Level (dBuV/m)	Limit (dBuV/m)	Margin (dB)	Antenna Height (m)	Table Angle (Degree)	Raw Value (dBuV)	Correction Factor (dB/m)
1	31.84	35.6	82.2	-46.6	1.50 H	355	23.1	12.5
2	78.51	44.6	82.2	-37.6	1.50 H	226	35.0	9.6
3	119.34	38.7	82.2	-43.5	1.50 H	10	26.2	12.5
4	558.75	43.2	82.2	-39.0	1.50 H	304	21.7	21.5
5	799.84	42.6	82.2	-39.6	1.00 H	133	17.4	25.2
6	883.44	41.1	82.2	-41.1	1.00 H	163	14.4	26.7
ANTENNA POLARITY & TEST DISTANCE: VERTICAL AT 3 M								
No.	Freq. (MHz)	Emission Level (dBuV/m)	Limit (dBuV/m)	Margin (dB)	Antenna Height (m)	Table Angle (Degree)	Raw Value (dBuV)	Correction Factor (dB/m)
1	55.18	46.8	82.2	-35.4	1.00 V	352	33.0	13.8
2	558.75	42.5	82.2	-39.7	1.50 V	259	21.0	21.5
3	720.12	43.2	82.2	-39.0	1.50 V	352	18.9	24.3
4	799.84	45.7	82.2	-36.5	1.50 V	280	20.5	25.2
5	883.44	48.1	82.2	-34.1	1.00 V	133	21.4	26.7
6	957.33	41.2	82.2	-41.0	1.00 V	334	13.6	27.6

NOTE:

1. Emission level (dBuV/m) = Raw Value (dBuV) + Correction Factor (dB).
2. Correction Factor (dB/m) = Antenna Factor (dB/m) + Cable Factor (dB).
3. The other emission levels were very low against the limit.
4. Margin value = Emission level – Limit value.
5. This is valid for all 3 channels.



MODE	TX channel 600	FREQUENCY RANGE	Below 1000MHz
ENVIRONMENTAL CONDITIONS	25deg. C, 65%RH	INPUT POWER	120Vac, 60 Hz
TEST MODE	B	TESTED BY	David Huang

ANTENNA POLARITY & TEST DISTANCE: HORIZONTAL AT 3 M								
No.	Freq. (MHz)	Emission Level (dBuV/m)	Limit (dBuV/m)	Margin (dB)	Antenna Height (m)	Table Angle (Degree)	Raw Value (dBuV)	Correction Factor (dB/m)
1	31.84	36.2	82.2	-46.0	2.00 H	322	23.7	12.5
2	78.51	37.6	82.2	-44.6	2.00 H	235	28.0	9.6
3	119.34	39.9	82.2	-42.3	2.00 H	10	27.4	12.5
4	360.43	41.2	82.2	-41.0	1.00 H	10	24.8	16.4
5	558.75	43.3	82.2	-38.9	2.00 H	313	21.8	21.5
6	877.61	42.1	82.2	-40.1	1.00 H	10	15.5	26.6
ANTENNA POLARITY & TEST DISTANCE: VERTICAL AT 3 M								
No.	Freq. (MHz)	Emission Level (dBuV/m)	Limit (dBuV/m)	Margin (dB)	Antenna Height (m)	Table Angle (Degree)	Raw Value (dBuV)	Correction Factor (dB/m)
1	53.23	46.6	82.2	-35.6	1.00 V	358	32.6	14.0
2	78.51	43.8	82.2	-38.4	2.00 V	145	34.2	9.6
3	560.69	41.1	82.2	-41.1	1.00 V	262	19.6	21.5
4	716.23	42.2	82.2	-40.0	2.00 V	271	17.9	24.3
5	799.84	46.7	82.2	-35.5	2.00 V	268	21.5	25.2
6	877.61	43.6	82.2	-38.6	1.00 V	322	17.0	26.6

NOTE:

1. Emission level (dBuV/m) = Raw Value (dBuV) + Correction Factor (dB).
2. Correction Factor (dB/m) = Antenna Factor (dB/m) + Cable Factor (dB).
3. The other emission levels were very low against the limit.
4. Margin value = Emission level – Limit value.
5. This is valid for all 3 channels.



4.7 RADIATED EMISSION MEASUREMENT (ABOVE 1GHz)

4.7.1 LIMITS OF RADIATED EMISSION MEASUREMENT

In the FCC 24.238(a), On any frequency outside a licensee's frequency block within USPCS spectrum, the power of any emission shall be attenuated below the transmitter power (P) by at least $43 + 10 \log (P)$ dB. The specified minimum attenuation becomes 43dB and the limit of emission equal to -13dBm .

4.7.2 TEST INSTRUMENTS

Same as 4.1.2.

4.7.3 TEST PROCEDURES

- a. Substitution method is used for E.I.R.P measurement. In the semi-anechoic chamber, EUT placed on the 0.8m height of Turn Table, rotated the table around 360 degrees to search the maximum radiation power and receiver antenna shall be rotated vertical and horizontal polarization and moved height from 1m to 4m to find the maximum polar radiated power. The “ Read Value ” is the spectrum reading the maximum power value.
- b. The substitution horn antenna is substituted for EUT at the same position and signals generator export the CW signal to the substitution antenna via a TX cable. Rotated the Turn Table and moved receiving antenna to find the maximum radiation power. Adjust output power level of S.G to get a Value of spectrum reading equal to “ Read Value “ of step a. Record the power level of S.G
- c. $EIRP = \text{Output power level of S.G} - \text{TX cable loss} + \text{Antenna gain of substitution horn.}$

NOTE: The resolution bandwidth and video bandwidth of test receiver/spectrum analyzer is 1MHz/3MHz.

4.7.4 DEVIATION FROM TEST STANDARD

No deviation

4.7.5 TEST SETUP

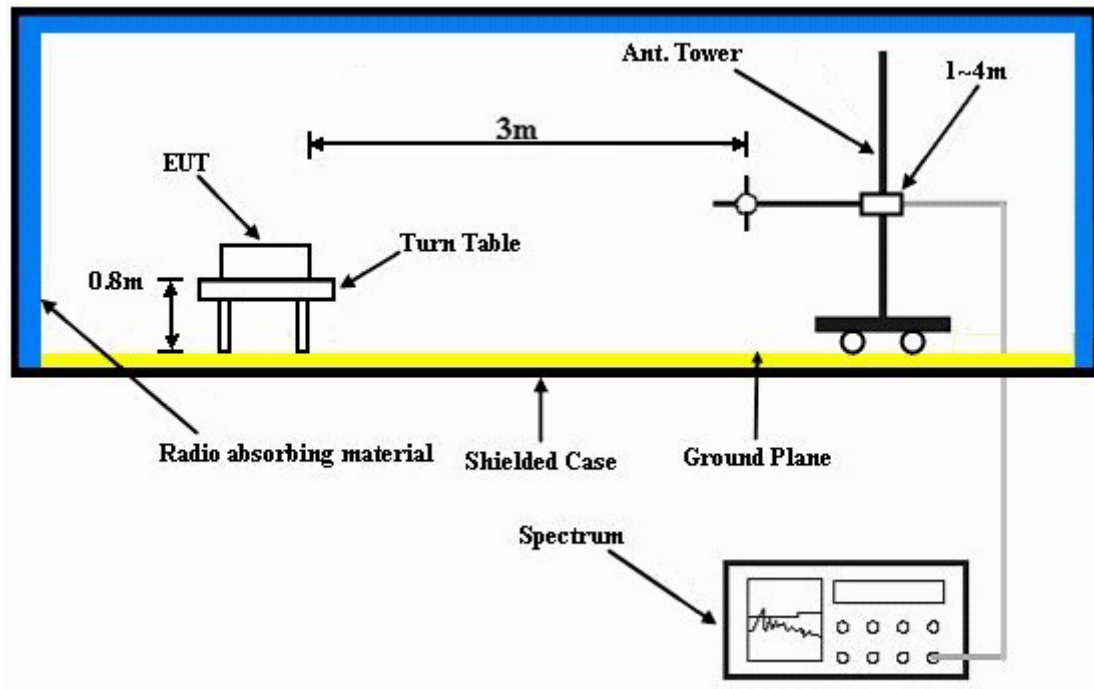

For the actual test configuration, please refer to the attached file (Test Setup Photo).

4.7.6 EUT OPERATING CONDITIONS

- a. The EUT makes a call to the communication simulator.
- b. The communication simulator station system controlled an EUT to export maximum output power under transmission mode and specific channel frequency.



4.7.7 TEST RESULTS

MODE	Channel 25	FREQUENCY RANGE	Above 1000MHz
INPUT POWER	120Vac, 60 Hz	ENVIRONMENTAL CONDITIONS	27deg. C, 65%RH
TEST MODE	A	TESTED BY	David Huang

ANTENNA POLARITY & TEST DISTANCE: HORIZONTAL AT 3 M						
NO.	FREQ. (MHz)	EMISSION LEVEL (dBuV)	LIMIT (dBm)	S.G POWER VALUE (dBm)	CORRECTION FACTOR (dB)	POWER VALUE (dBm)
1	3702.50	41.5	-13.0	-63.0	9.9	-53.1
2	5553.75	36.7	-13.0	-67.5	9.7	-57.8
3	7405.00	42.3	-13.0	-60.3	7.9	-52.4
ANTENNA POLARITY & TEST DISTANCE: VERTICAL AT 3 M						
NO.	FREQ. (MHz)	EMISSION LEVEL (dBuV)	LIMIT (dBm)	S.G POWER VALUE (dBm)	CORRECTION FACTOR (dB)	POWER VALUE (dBm)
1	3702.50	58.6	-13.0	-45.9	9.9	-36.0
2	5553.75	37.2	-13.0	-67.0	9.7	-57.3
3	7405.00	42.3	-13.0	-60.3	7.9	-52.4

NOTE: Power Value (dBum) = S.G Power Value (dBm) + Correction Factor (dB).



MODE	Channel 600	FREQUENCY RANGE	Above 1000MHz
INPUT POWER	120Vac, 60 Hz	ENVIRONMENTAL CONDITIONS	27deg. C, 65%RH
TEST MODE	A	TESTED BY	David Huang

ANTENNA POLARITY & TEST DISTANCE: HORIZONTAL AT 3 M						
NO.	FREQ. (MHz)	EMISSION LEVEL (dBuV)	LIMIT (dBm)	S.G POWER VALUE (dBm)	CORRECTION FACTOR (dB)	POWER VALUE (dBm)
1	3760.00	41.7	-13.0	-62.7	9.9	-52.8
2	5640.00	37.0	-13.0	-67.3	9.6	-57.7
3	7520.00	42.1	-13.0	-60.3	7.8	-52.5
ANTENNA POLARITY & TEST DISTANCE: VERTICAL AT 3 M						
NO.	FREQ. (MHz)	EMISSION LEVEL (dBuV)	LIMIT (dBm)	S.G POWER VALUE (dBm)	CORRECTION FACTOR (dB)	POWER VALUE (dBm)
1	3760.00	42.1	-13.0	-62.3	9.9	-52.4
2	5640.00	36.8	-13.0	-67.5	9.6	-57.9
3	7520.00	40.7	-13.0	-61.7	7.8	-53.9

NOTE: Power Value (dBum) = S.G Power Value (dBm) + Correction Factor (dB).



MODE	Channel 1175	FREQUENCY RANGE	Above 1000MHz
INPUT POWER	120Vac, 60 Hz	ENVIRONMENTAL CONDITIONS	27deg. C, 65%RH
TEST MODE	A	TESTED BY	David Huang

ANTENNA POLARITY & TEST DISTANCE: HORIZONTAL AT 3 M						
NO.	FREQ. (MHz)	EMISSION LEVEL (dBuV)	LIMIT (dBm)	S.G POWER VALUE (dBm)	CORRECTION FACTOR (dB)	POWER VALUE (dBm)
1	3817.50	40.8	-13.0	-63.6	9.9	-53.7
2	5726.25	37.4	-13.0	-66.6	9.6	-57.0
3	7635.00	42.0	-13.0	-60.5	7.8	-52.7
ANTENNA POLARITY & TEST DISTANCE: VERTICAL AT 3 M						
NO.	FREQ. (MHz)	EMISSION LEVEL (dBuV)	LIMIT (dBm)	S.G POWER VALUE (dBm)	CORRECTION FACTOR (dB)	POWER VALUE (dBm)
1	3817.50	44.5	-13.0	-59.9	9.9	-50.0
2	5726.25	37.3	-13.0	-66.7	9.6	-57.1
3	7635.00	41.8	-13.0	-60.7	7.8	-52.9

NOTE: Power Value (dBum) = S.G Power Value (dBm) + Correction Factor (dB).



MODE	Channel 25	FREQUENCY RANGE	Above 1000MHz
INPUT POWER	120Vac, 60 Hz	ENVIRONMENTAL CONDITIONS	27deg. C, 65%RH
TEST MODE	B	TESTED BY	David Huang

ANTENNA POLARITY & TEST DISTANCE: HORIZONTAL AT 3 M

NO.	FREQ. (MHz)	EMISSION LEVEL (dBuV)	LIMIT (dBm)	S.G POWER VALUE (dBm)	CORRECTION FACTOR (dB)	POWER VALUE (dBm)
1	3702.50	46.9	-13.0	-57.6	9.9	-47.7
2	5553.75	43.5	-13.0	-60.7	9.7	-51.0
3	7405.00	41.4	-13.0	-61.2	7.9	-53.3

ANTENNA POLARITY & TEST DISTANCE: VERTICAL AT 3 M

NO.	FREQ. (MHz)	EMISSION LEVEL (dBuV)	LIMIT (dBm)	S.G POWER VALUE (dBm)	CORRECTION FACTOR (dB)	POWER VALUE (dBm)
1	3702.50	46.5	-13.0	-58.0	9.9	-48.1
2	5553.75	41.5	-13.0	-62.7	9.7	-53.0
3	7405.00	41.9	-13.0	-60.7	7.9	-52.8

NOTE: Power Value (dBum) = S.G Power Value (dBm) + Correction Factor (dB).



MODE	Channel 600	FREQUENCY RANGE	Above 1000MHz
INPUT POWER	120Vac, 60 Hz	ENVIRONMENTAL CONDITIONS	27deg. C, 65%RH
TEST MODE	B	TESTED BY	David Huang

ANTENNA POLARITY & TEST DISTANCE: HORIZONTAL AT 3 M						
NO.	FREQ. (MHz)	EMISSION LEVEL (dBuV)	LIMIT (dBm)	S.G POWER VALUE (dBm)	CORRECTION FACTOR (dB)	POWER VALUE (dBm)
1	3760.00	53.4	-13.0	-51.0	9.9	-41.1
2	5640.00	37.3	-13.0	-67.0	9.6	-57.4
3	7520.00	42.0	-13.0	-60.4	7.8	-52.6
ANTENNA POLARITY & TEST DISTANCE: VERTICAL AT 3 M						
NO.	FREQ. (MHz)	EMISSION LEVEL (dBuV)	LIMIT (dBm)	S.G POWER VALUE (dBm)	CORRECTION FACTOR (dB)	POWER VALUE (dBm)
1	3760.00	51.6	-13.0	-52.8	9.9	-42.9
2	5640.00	42.5	-13.0	-61.8	9.6	-52.2
3	7520.00	41.8	-13.0	-60.6	7.8	-52.8

NOTE: Power Value (dBum) = S.G Power Value (dBm) + Correction Factor (dB).



MODE	Channel 1175	FREQUENCY RANGE	Above 1000MHz
INPUT POWER	120Vac, 60 Hz	ENVIRONMENTAL CONDITIONS	27deg. C, 65%RH
TEST MODE	B	TESTED BY	David Huang

ANTENNA POLARITY & TEST DISTANCE: HORIZONTAL AT 3 M						
NO.	FREQ. (MHz)	EMISSION LEVEL (dBuV)	LIMIT (dBm)	S.G POWER VALUE (dBm)	CORRECTION FACTOR (dB)	POWER VALUE (dBm)
1	3817.50	43.3	-13.0	-61.1	9.9	-51.2
2	5726.25	46.8	-13.0	-57.2	9.6	-47.6
3	7635.00	42.2	-13.0	-60.3	7.8	-52.5
ANTENNA POLARITY & TEST DISTANCE: VERTICAL AT 3 M						
NO.	FREQ. (MHz)	EMISSION LEVEL (dBuV)	LIMIT (dBm)	S.G POWER VALUE (dBm)	CORRECTION FACTOR (dB)	POWER VALUE (dBm)
1	3817.50	48.5	-13.0	-55.9	9.9	-46.0
2	5726.25	42.8	-13.0	-61.2	9.6	-51.6
3	7635.00	42.3	-13.0	-60.2	7.8	-52.4

NOTE: Power Value (dBum) = S.G Power Value (dBm) + Correction Factor (dB).



5 PHOTOGRAPHS OF THE TEST CONFIGURATION

Please refer to the attached file (Test Setup Photo).



6 INFORMATION ON THE TESTING LABORATORIES

We, Bureau Veritas Consumer Products Services (H.K.) Ltd., Taoyuan Branch, were founded in 1988 to provide our best service in EMC, Radio, Telecom and Safety consultation. Our laboratories are accredited and approved according to ISO/IEC 17025.

Copies of accreditation certificates of our laboratories obtained from approval agencies can be downloaded from our web site: www.adt.com.tw/index.5.phtml.
If you have any comments, please feel free to contact us at the following:

Linko EMC/RF Lab:

Tel: 886-2-26052180

Fax: 886-2-26051924

Hsin Chu EMC/RF Lab:

Tel: 886-3-5935343

Fax: 886-3-5935342

Hwa Ya EMC/RF/Safety/Telecom Lab:

Tel: 886-3-3183232

Fax: 886-3-3185050

Email: service.adt@tw.bureauveritas.com

Web Site: www.adt.com.tw

The address and road map of all our labs can be found in our web site also.



7 APPENDIX A – MODIFICATIONS RECORDERS FOR ENGINEERING CHANGES TO THE EUT BY THE LAB

No any modifications are made to the EUT by the lab during the test.

---END---