

# FCC RF Test Report

APPLICANT : HTC Corporation  
EQUIPMENT : Smart Phone  
MODEL NAME : PG86100  
FCC ID : NM8PG86100  
STANDARD : 47 CFR Part 2, 27(M)  
CLASSIFICATION : Licensed Non-Broadcast Station Transmitter  
Held to Ear (TNE)  
TX FREQUENCY RANGE : 2496 MHz ~ 2690 MHz  
Rx FREQUENCY RANGE : 2496 MHz ~ 2690 MHz  
MAX. EIRP POWER : 0.09 W (QPSK, BW 5MHz)  
0.07 W (QPSK, BW 10MHz)  
0.09 W (16QAM, BW 5MHz)  
0.07 W (16QAM, BW 10MHz)  
EMISSION DESIGNATOR : 4M48G7D (QPSK, BW 5MHz)  
9M12G7D (QPSK, BW 10MHz)  
4M48W7D (16QAM, BW 5MHz)  
9M12W7D (16QAM, BW 10MHz)

The product was received on Jan. 20, 2011 and completely tested on Mar. 28, 2011. We, SPORTON INTERNATIONAL INC., would like to declare that the tested sample has been evaluated in accordance with the procedures given in ANSI C63.4-2003 and 47 CFR FCC Part 27 Subpart M and shown compliance with the applicable technical standards.

The test results in this report apply exclusively to the tested model / sample. Without written approval of SPORTON INTERNATIONAL INC., the test report shall not be reproduced except in full.

Reviewed by:

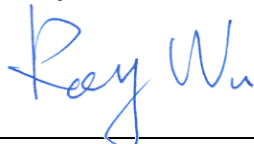

Roy Wu / Manager



## SPORTON INTERNATIONAL INC.

No. 52, Hwa Ya 1<sup>st</sup> Rd., Hwa Ya Technology Park, Kwei-Shan Hsiang, Tao Yuan Hsien, Taiwan, R.O.C.



# TABLE OF CONTENTS

**REVISION HISTORY..... 3**

**SUMMARY OF TEST RESULT ..... 4**

**1 GENERAL DESCRIPTION ..... 5**

    1.1 Applicant ..... 5

    1.2 Manufacturer ..... 5

    1.3 Feature of Equipment Under Test ..... 5

    1.4 Testing Site ..... 6

    1.5 Applied Standards ..... 6

    1.6 Ancillary Equipment List ..... 6

**2 TEST CONFIGURATION OF EQUIPMENT UNDER TEST ..... 7**

    2.1 Test Mode ..... 7

    2.2 Connection Diagram of Test System ..... 8

**3 TEST RESULT ..... 9**

    3.1 Maximum Output Power, Band Edge, and Effective Isotropic Radiated Power Measurement ..... 9

    3.2 Emission Bandwidth ..... 18

    3.3 Conducted Spurious Emission Measurement ..... 23

    3.4 Radiated Emissions Measurement ..... 36

    3.5 Frequency Stability Measurement ..... 46

**4 LIST OF MEASURING EQUIPMENTS..... 49**

**5 UNCERTAINTY OF EVALUATION ..... 50**

**APPENDIX A. SETUP PHOTOGRAPHS**



### REVISION HISTORY

REPORT NO.	VERSION	DESCRIPTION	ISSUED DATE
FG112033B	Rev. 01	Initial issue of report	Apr. 01, 2011



### SUMMARY OF TEST RESULT

Report Section	FCC Rule	Description	Limit	Result	Remark
3.1	§2.1033 §2.1046 §27.50	Maximum Output Power	< 2 Watts	PASS	-
3.1	§2.1033 §2.1046 §27.50	Band Edge Emissions	< 5.5MHz: -13 dBm ≥5.5MHz: -25 dBm	PASS	-
3.1	§27.50	Equivalent Isotropic Radiated Power	< 2 Watts	PASS	-
3.2	§2.1049 §27.53	Emissions Bandwidth	N/A	PASS	-
3.3	§2.1051 §27.53	Conducted Spurious Emissions	< 55+10log <sub>10</sub> (P[Watts])	PASS	-
3.4	§2.1053 §27.53	Field Strength of Spurious Radiation	< 55+10log <sub>10</sub> (P[Watts])	PASS	Under limit 0.93 dB at 7779 MHz
3.5	§2.1055 §27.54	Frequency Stability for Temperature & Voltage	2.5 ppm	PASS	-



# 1 General Description

## 1.1 Applicant

HTC Corporation

1F., No. 6-3, Baoqiang Rd., Xindian City, Taipei, Taiwan

## 1.2 Manufacturer

HTC Corporation

1F., No. 6-3, Baoqiang Rd., Xindian City, Taipei, Taiwan

## 1.3 Feature of Equipment Under Test

Product Feature & Specification	
Equipment	Smart Phone
Model Name	PG86100
FCC ID	NM8PG86100
Tx Frequency	2496 MHz ~ 2690 MHz
Rx Frequency	2496 MHz ~ 2690 MHz
Channel Bandwidth	5MHz / 10MHz
Maximum Output Power to Antenna	24.50 dBm (QPSK, BW 5MHz) 24.31 dBm (QPSK, BW 10MHz) 24.33 dBm (16QAM, BW 5MHz) 24.14 dBm (16QAM, BW 10MHz)
Maximum EIRP	0.09 W (19.34 dBm) (QPSK, BW 5MHz) 0.07 W (18.29 dBm) (QPSK, BW 10MHz) 0.09 W (19.30 dBm) (16QAM, BW 5MHz) 0.07 W (18.28 dBm) (16QAM, BW 10MHz)
Antenna Type	PIFA Antenna
Type of Modulation	Uplink : OFDMA (QPSK / 16QAM / 64QAM) Downlink : OFDMA (QPSK / 16QAM / 64QAM)
Type of Emission	4M48G7D (QPSK, BW 5MHz) 9M12G7D (QPSK, BW 10MHz) 4M48W7D (16QAM, BW 5MHz) 9M12W7D (16QAM, BW 10MHz)
EUT Stage	Production Unit

**Remark:**

1. For other wireless features of this EUT, the test report will be issued separately.
2. This test report recorded only product characteristics and test results of Licensed Non-Broadcast Station Transmitter Held to Ear (TNE).
3. The above EUT's information was declared by manufacturer. Please refer to the specifications or user's manual for more detailed description.

## 1.4 Testing Site

<b>Test Site</b>	SPORTON INTERNATIONAL INC.		
<b>Test Site Location</b>	No. 52, Hwa Ya 1 <sup>st</sup> Rd., Hwa Ya Technology Park, Kwei-Shan Hsiang, Tao Yuan Hsien, Taiwan, R.O.C. TEL: +886-3-327-3456 FAX: +886-3-328-4978		
<b>Test Site No.</b>	<b>Sporton Site No.</b>		<b>FCC / IC Registration No.</b>
	TH02-HY	03CH06-HY	722060/4086B-1

## 1.5 Applied Standards

According to the specifications of the manufacturer, the EUT must comply with the requirements of the following standards:

- ♦ 47 CFR Part 2, 27(M)
- ♦ ANSI C63.4-2003
- ♦ ANSI TIA-603-C-2004

**Remark:**

1. All test items were verified and recorded according to the standards and without any deviation during the test.
2. This EUT has also been tested and complied with the requirements of FCC Part 15, Subpart B (DoC), recorded in a separate test report.

## 1.6 Ancillary Equipment List

Item	Equipment	Trade Name	Model No.	FCC ID	Data Cable	Power Cord
1.	System Simulator	Agilent	E6651A	N/A	N/A	Unshielded, 1.8 m

## 2 Test Configuration of Equipment Under Test

### 2.1 Test Mode

Preliminary tests were performed in different data rate to find the worst radiated emission. The data rate shown in the table below is the worst-case rate with respect to the specific test item. Investigation has been done on all the possible configurations for searching the worst cases. The following table is a list of the test modes shown in this test report. The spurious emission measurements were carried out in semi-anechoic chamber with 3-meter test range.

Test Modes		
Band	Radiated TCs	Conducted TCs
802.16e (Modulation : OFDMA)	<ul style="list-style-type: none"> <li>■ QPSK, BW 5MHz Link</li> <li>■ QPSK, BW 10MHz Link</li> <li>■ 16QAM, BW 5MHz Link</li> <li>■ 16QAM, BW 10MHz Link</li> </ul>	<ul style="list-style-type: none"> <li>■ QPSK, BW 5MHz Link</li> <li>■ QPSK, BW 10MHz Link</li> <li>■ 16QAM, BW 5MHz Link</li> <li>■ 16QAM, BW 10MHz Link</li> </ul>

**Note:** The maximum average power levels are on zone type, PUSC and coding rate, 1/2 mode for QPSK, BW 5MHz, QPSK, BW 10MHz, 16QAM, BW 5MHz, and 16QAM, BW 10MHz Link ; only these modes were used for all tests.

The conducted power tables are as follows:

Average Conducted Power (*Unit: dBm)							
Channel	Modulation Type	Zone Type	Coding Rate	Main Antenna		Aux. Antenna	
				5MHz Bandwidth	10MHz Bandwidth	5MHz Bandwidth	10MHz Bandwidth
Low	QPSK	PUSC	1/2	23.34	23.00	23.07	22.78
			3/4	23.24	22.90	23.03	22.74
Middle	QPSK	PUSC	1/2	24.50	24.31	23.85	23.70
			3/4	24.45	24.23	23.83	23.68
High	QPSK	PUSC	1/2	23.93	23.71	23.47	23.23
			3/4	23.84	23.64	23.42	23.17
Low	16QAM	PUSC	1/2	23.09	22.80	22.95	22.67
			3/4	22.98	22.63	22.87	22.50
Middle	16QAM	PUSC	1/2	24.33	24.14	23.76	23.54
			3/4	24.32	24.04	23.75	23.33
High	16QAM	PUSC	1/2	23.77	23.35	23.36	23.09
			3/4	23.60	23.44	23.21	22.92

## 2.2 Connection Diagram of Test System

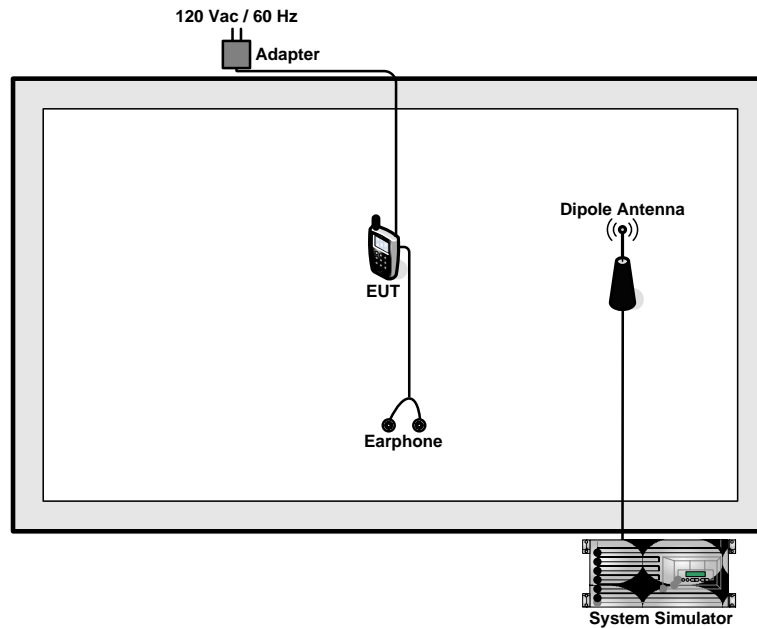



### 3 Test Result

#### 3.1 Maximum Output Power, Band Edge, and Effective Isotropic Radiated Power Measurement

##### 3.1.1 Limit

For mobile and other user stations, mobile stations are limited to 2.0 watts EIRP and all user stations are limited to 2.0 watts transmitter output power. The power of any emission outside of the authorized operating frequency ranges must be attenuated below the transmitting power ( $p$ ) by a factor of mobile digital stations, the attenuation factor shall be not less than  $43 + 10 \log (p)$  dB at the channel edge and  $55 + 10 \log (p)$  dB at 5.5 MHz from the channel edges.

##### 3.1.2 Measuring Instruments

See list of measuring instruments of this test report.

##### 3.1.3 Test Procedures

###### For Conducted Power and Band Edge Measurement:

The RF output of the transmitter was connected to the input of the spectrum analyzer through sufficient attenuation.

###### For Effective Isotropic Radiated Power Measurement:

1. The EUT was placed on an non-conductive rotating platform with 0.8 meter height in a semi-anechoic chamber. The radiated emission at the fundamental frequency was measured at 3 m.
2. During the measurement, the EUT was enforced in maximum power. The highest emission was recorded from analyzer power level (LVL) from the 360 degrees rotation of the turntable and the test antenna raised and lowered over a range from 1 to 4 meters in both horizontally and vertically polarized orientations.
3. Effective Isotropic Radiated Power (EIRP) was measured by substitution method according to TIA/EIA-603-C. The EUT was replaced by dipole antenna (substitution antenna) at same location, and then a known power from S.G. was applied into the dipole antenna through a Tx cable, and then recorded the maximum Analyzer reading through raised and lowered the test antenna. The correction factor (in dB) = S.G. - Tx Cable loss + Substitution antenna gain - Analyzer reading. Then the EUT's EIRP was calculated with the correction factor,  $EIRP = LVL + \text{Correction factor}$ .

### 3.1.4 Test Setup

#### <Conducted Power and Band Edge Measurement>

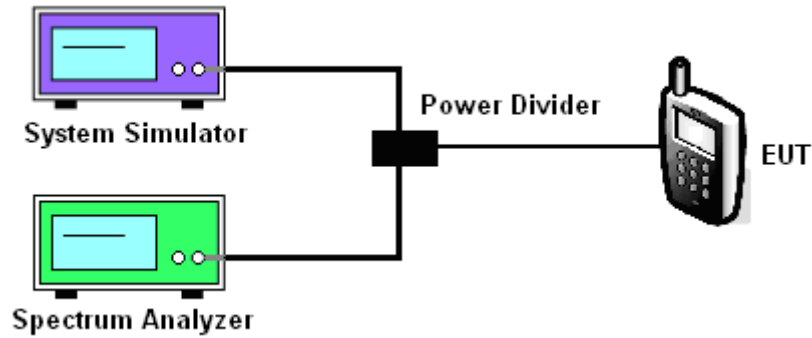

#### <Effective Isotropic Radiated Power Measurement>

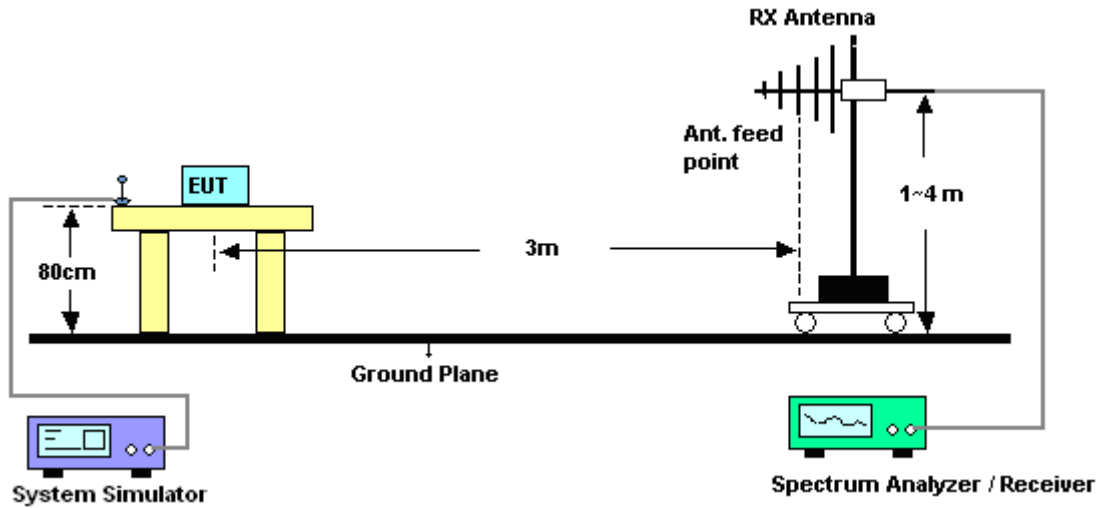



3.1.5 Test Result of Maximum Output Power

Channel	Modulation Type	Zone Type	Coding Rate	Average Power (Unit: dBm)	
				5MHz Bandwidth	10MHz Bandwidth
Low	QPSK	PUSC	1/2	23.34	23.00
Middle	QPSK	PUSC	1/2	24.50	24.31
High	QPSK	PUSC	1/2	23.93	23.71

Channel	Modulation Type	Zone Type	Coding Rate	Average Power (Unit: dBm)	
				5MHz Bandwidth	10MHz Bandwidth
Low	16QAM	PUSC	1/2	23.09	22.80
Middle	16QAM	PUSC	1/2	24.33	24.14
High	16QAM	PUSC	1/2	23.77	23.35



### 3.1.6 Test Result of Band Edge Measurement

<b>Band :</b>	802.16e	<b>Power Stage :</b>	High
<b>Test Mode :</b>	QPSK, BW 5MHz		

#### Band Edge Plot on Low Channel

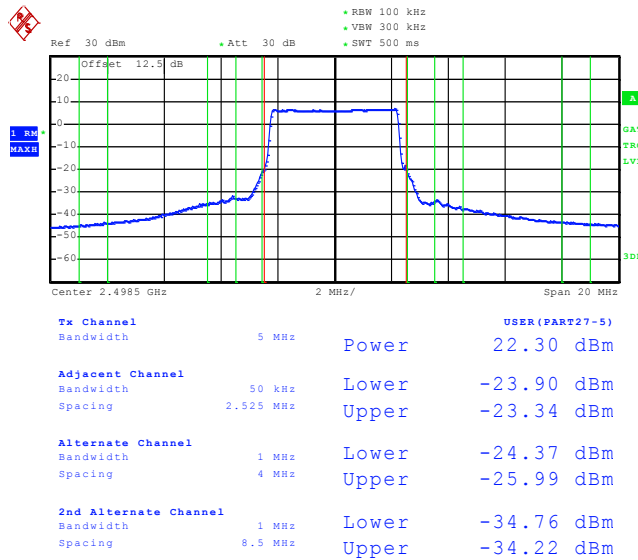

Date: 28.MAR.2011 18:13:27

#### Band Edge Plot on High Channel

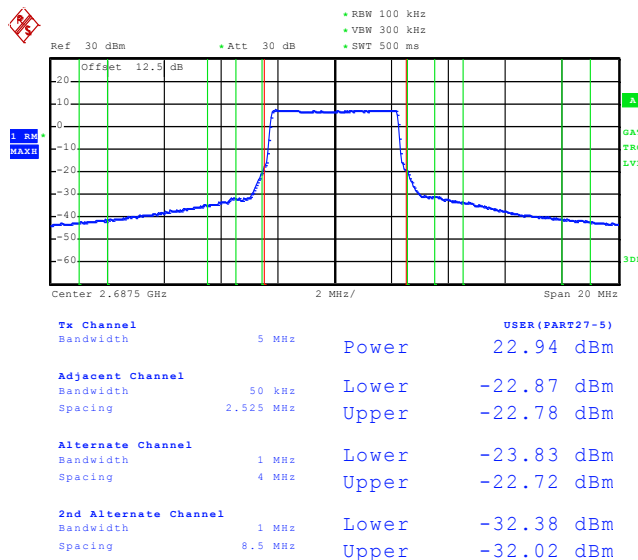

Date: 28.MAR.2011 18:15:35



<b>Band :</b>	802.16e	<b>Power Stage :</b>	High
<b>Test Mode :</b>	QPSK, BW 10MHz		

**Edge Plot on Low Channel**

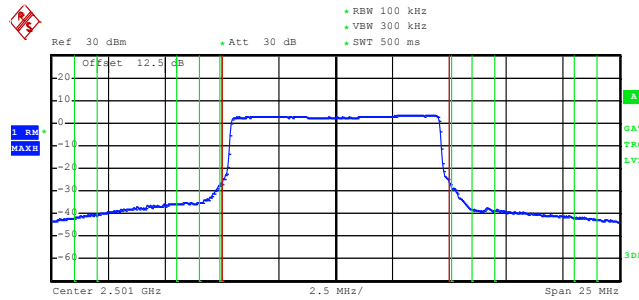

<b>Tx Channel</b>	Bandwidth	10 MHz	Power	22.13 dBm	USER (PART27-10)
<b>Adjacent Channel</b>	Bandwidth	100 kHz	Lower	-27.26 dBm	
	Spacing	5.05 MHz	Upper	-27.06 dBm	
<b>Alternate Channel</b>	Bandwidth	1 MHz	Lower	-25.80 dBm	
	Spacing	6.5 MHz	Upper	-28.72 dBm	
<b>2nd Alternate Channel</b>	Bandwidth	1 MHz	Lower	-31.28 dBm	
	Spacing	11 MHz	Upper	-32.53 dBm	

Bandedge limit: -13dBm

Bandedge limit: -13dBm

Bandedge limit: -25dBm

Date: 28.MAR.2011 17:18:21

**Band Edge Plot on High Channel**

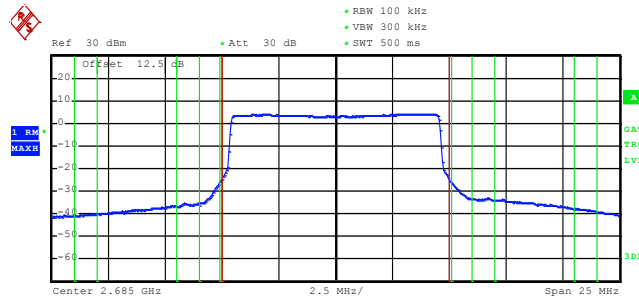

<b>Tx Channel</b>	Bandwidth	10 MHz	Power	22.84 dBm	USER (PART27-10)
<b>Adjacent Channel</b>	Bandwidth	100 kHz	Lower	-25.81 dBm	
	Spacing	5.05 MHz	Upper	-25.87 dBm	
<b>Alternate Channel</b>	Bandwidth	1 MHz	Lower	-26.33 dBm	
	Spacing	6.5 MHz	Upper	-23.86 dBm	
<b>2nd Alternate Channel</b>	Bandwidth	1 MHz	Lower	-30.81 dBm	
	Spacing	11 MHz	Upper	-28.62 dBm	

Bandedge limit: -13dBm

Bandedge limit: -13dBm

Bandedge limit: -25dBm

Date: 28.MAR.2011 17:13:33



<b>Band :</b>	802.16e	<b>Power Stage :</b>	High
<b>Test Mode :</b>	16QAM, BW 5MHz		

**Band Edge Plot on Low Channel**

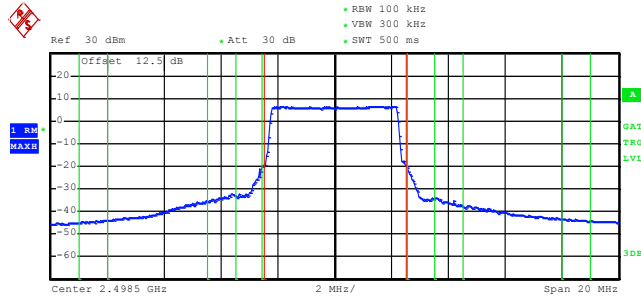

<b>Tx Channel</b>		<b>USER (PART27-5)</b>	
Bandwidth	5 MHz	Power	22.22 dBm
<b>Adjacent Channel</b>		Lower	-23.08 dBm
Bandwidth	50 kHz	Upper	-22.54 dBm
Spacing	2.525 MHz		
<b>Alternate Channel</b>		Lower	-24.35 dBm
Bandwidth	1 MHz	Upper	-26.03 dBm
Spacing	4 MHz		
<b>2nd Alternate Channel</b>		Lower	-34.82 dBm
Bandwidth	1 MHz	Upper	-34.16 dBm
Spacing	8.5 MHz		

Bandedge limit: -13dBm  
 Bandedge limit: -13dBm  
 Bandedge limit: -25dBm

Date: 28.MAR.2011 18:14:06

**Band Edge Plot on High Channel**

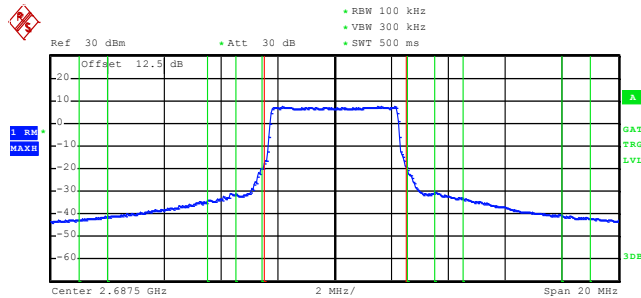

<b>Tx Channel</b>		<b>USER (PART27-5)</b>	
Bandwidth	5 MHz	Power	22.97 dBm
<b>Adjacent Channel</b>		Lower	-23.08 dBm
Bandwidth	50 kHz	Upper	-22.73 dBm
Spacing	2.525 MHz		
<b>Alternate Channel</b>		Lower	-23.42 dBm
Bandwidth	1 MHz	Upper	-22.48 dBm
Spacing	4 MHz		
<b>2nd Alternate Channel</b>		Lower	-32.37 dBm
Bandwidth	1 MHz	Upper	-31.99 dBm
Spacing	8.5 MHz		

Bandedge limit: -13dBm  
 Bandedge limit: -13dBm  
 Bandedge limit: -25dBm

Date: 28.MAR.2011 18:15:01



<b>Band :</b>	802.16e	<b>Power Stage :</b>	High
<b>Test Mode :</b>	16QAM, BW 10MHz		

**Band Edge Plot on Low Channel**

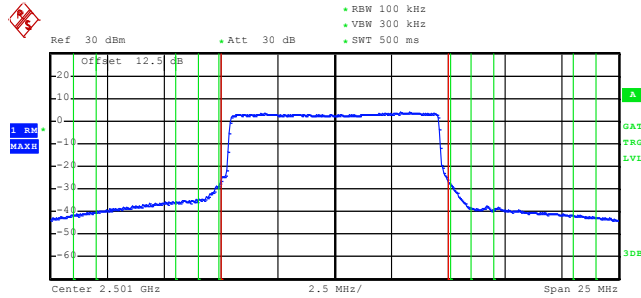

<b>Tx Channel</b>	Bandwidth	10 MHz	Power	22.14 dBm	USER (PART27-10)
<b>Adjacent Channel</b>	Bandwidth	100 kHz	Lower	-28.01 dBm	
	Spacing	5.05 MHz	Upper	-27.61 dBm	
<b>Alternate Channel</b>	Bandwidth	1 MHz	Lower	-25.89 dBm	
	Spacing	6.5 MHz	Upper	-28.93 dBm	
<b>2nd Alternate Channel</b>	Bandwidth	1 MHz	Lower	-31.33 dBm	
	Spacing	11 MHz	Upper	-32.62 dBm	

Bandedge limit: -13dBm

Bandedge limit: -13dBm

Bandedge limit: -25dBm

Date: 28.MAR.2011 17:17:31

**Band Edge Plot on High Channel**

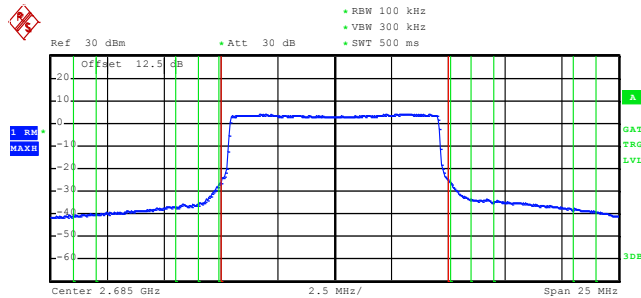

<b>Tx Channel</b>	Bandwidth	10 MHz	Power	22.68 dBm	USER (PART27-10)
<b>Adjacent Channel</b>	Bandwidth	100 kHz	Lower	-26.90 dBm	
	Spacing	5.05 MHz	Upper	-26.28 dBm	
<b>Alternate Channel</b>	Bandwidth	1 MHz	Lower	-26.76 dBm	
	Spacing	6.5 MHz	Upper	-24.40 dBm	
<b>2nd Alternate Channel</b>	Bandwidth	1 MHz	Lower	-30.87 dBm	
	Spacing	11 MHz	Upper	-28.95 dBm	

Bandedge limit: -13dBm

Bandedge limit: -13dBm

Bandedge limit: -25dBm

Date: 28.MAR.2011 17:12:42

3.1.7 Test Result of Effective Isotropic Radiated Power

802.16e (QPSK, BW 5MHz) Radiated Power (EIRP)				
Horizontal Polarization				
Channel	LVL (dBm)	Correction Factor (dB)	EIRP (dBm)	EIRP (W)
Low	-29.71	43.34242	13.63	0.02
Middle	-29.72	44.26775	14.55	0.03
High	-37.50	43.80508	6.31	0.00
Vertical Polarization				
Channel	LVL (dBm)	Correction Factor (dB)	EIRP (dBm)	EIRP (W)
Low	-26.61	43.12242	16.51	0.04
Middle	-25.24	44.57775	19.34	0.09
High	-31.73	44.03508	12.31	0.02

802.16e (QPSK, BW 10MHz) Radiated Power (EIRP)				
Horizontal Polarization				
Channel	LVL (dBm)	Correction Factor (dB)	EIRP (dBm)	EIRP (W)
Low	-30.05	43.34242	13.29	0.02
Middle	-32.45	44.26775	11.82	0.02
High	-38.65	43.80508	5.16	0.00
Vertical Polarization				
Channel	LVL (dBm)	Correction Factor (dB)	EIRP (dBm)	EIRP (W)
Low	-28.21	43.12242	14.91	0.03
Middle	-26.29	44.57775	18.29	0.07
High	-33.16	44.03508	10.88	0.01





802.16e (16QAM, BW 5MHz) Radiated Power (EIRP)				
Horizontal Polarization				
Channel	LVL (dBm)	Correction Factor (dB)	EIRP (dBm)	EIRP (W)
Low	-29.69	43.34242	13.65	0.02
Middle	-29.77	44.26775	14.50	0.03
High	-37.75	43.80508	6.06	0.00
Vertical Polarization				
Channel	LVL (dBm)	Correction Factor (dB)	EIRP (dBm)	EIRP (W)
Low	-26.66	43.12242	16.46	0.04
Middle	-25.28	44.57775	19.30	0.09
High	-31.71	44.03508	12.33	0.02

802.16e (16QAM, BW 10MHz) Radiated Power (EIRP)				
Horizontal Polarization				
Channel	LVL (dBm)	Correction Factor (dB)	EIRP (dBm)	EIRP (W)
Low	-30.05	43.34242	13.29	0.02
Middle	-32.48	44.26775	11.79	0.02
High	-38.56	43.80508	5.25	0.00
Vertical Polarization				
Channel	LVL (dBm)	Correction Factor (dB)	EIRP (dBm)	EIRP (W)
Low	-28.25	43.12242	14.87	0.03
Middle	-26.30	44.57775	18.28	0.07
High	-33.00	44.03508	11.04	0.01

## 3.2 Emission Bandwidth

### 3.2.1 Description of Emission Bandwidth Measurement

The emission bandwidth is defined as the width of the signal between two points, located at the 2 sides of the carrier frequency, outside of which all emissions are attenuated at least 26 dB below the transmitter power. The designated emission bandwidth using a resolution bandwidth of at least 1% of the emission bandwidth of the fundamental emission and a video bandwidth is more than resolution bandwidth.

### 3.2.2 Measuring Instruments

See list of measuring instruments of this test report.

### 3.2.3 Test Procedures

1. The EUT was connected to Spectrum Analyzer and System Simulator via power divider.
2. The 99% and 26 dB occupied bandwidth (BW) of the middle channel for the highest RF powers were measured.

### 3.2.4 Test Setup

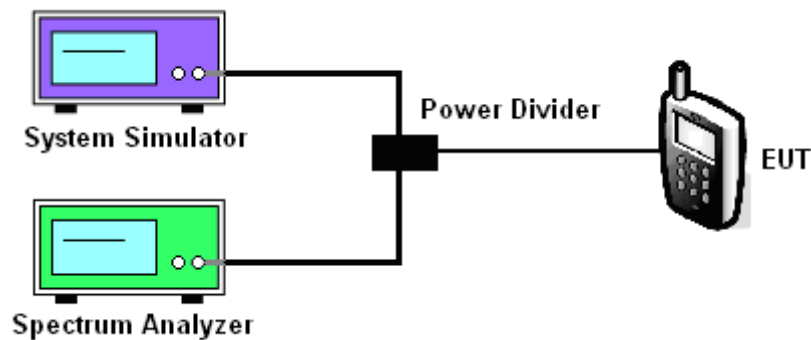



### 3.2.5 Test Result of Emission Bandwidth

<b>Band :</b>	802.16e	<b>Power Stage :</b>	High
<b>Test Mode :</b>	QPSK, BW 5MHz		

99% Occupied Bandwidth Plot on Middle Channel

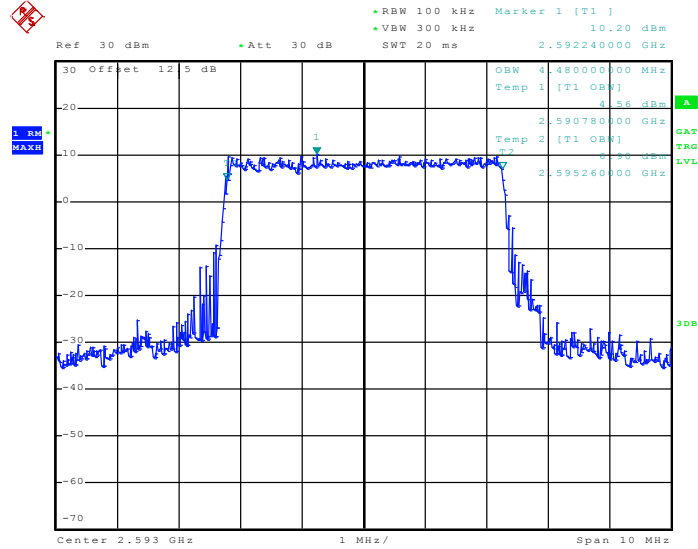

Date: 28.MAR.2011 17:33:34

26dB Bandwidth Plot on Middle Channel

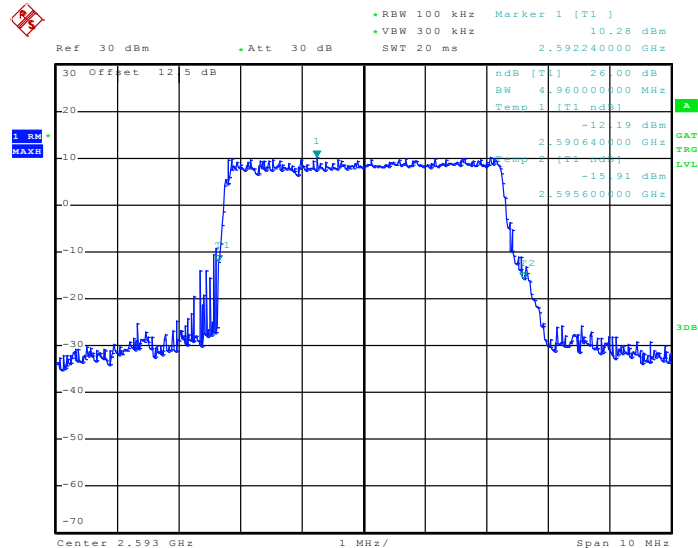

Date: 28.MAR.2011 17:34:26



Band :	802.16e	Power Stage :	High
Test Mode :	QPSK, BW 10MHz		

99% Occupied Bandwidth Plot on Middle Channel

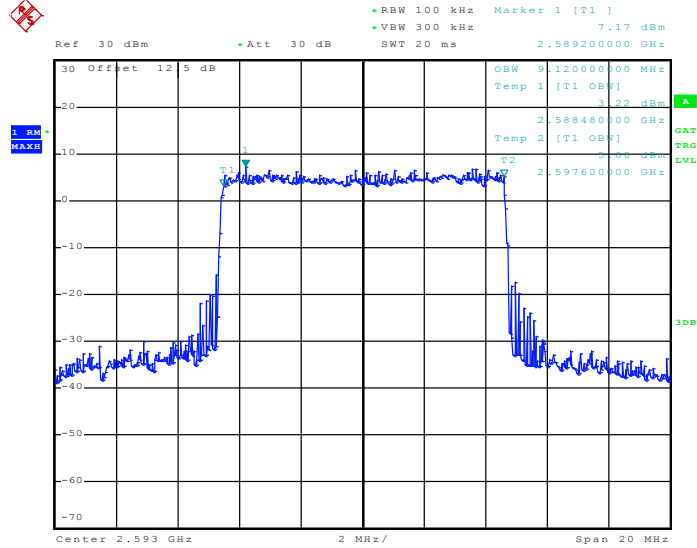

Date: 28.MAR.2011 16:44:09

26dB Bandwidth Plot on Middle Channel

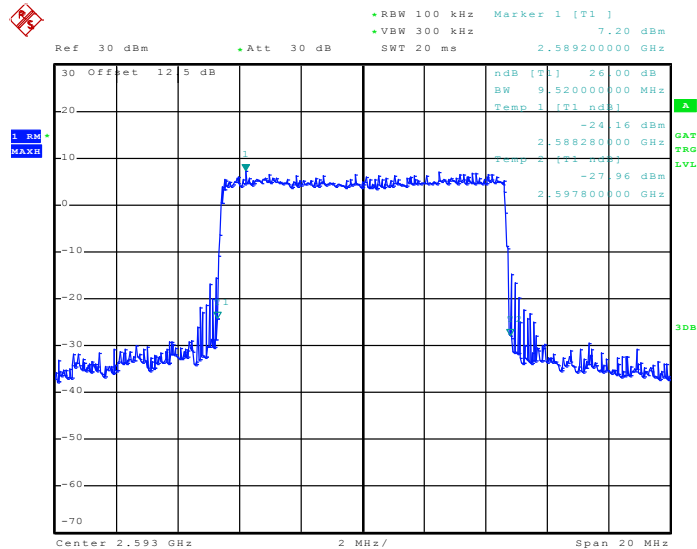

Date: 28.MAR.2011 16:38:52



<b>Band :</b>	802.16e	<b>Power Stage :</b>	High
<b>Test Mode :</b>	16QAM, BW 5MHz		

**99% Occupied Bandwidth Plot on Middle Channel**

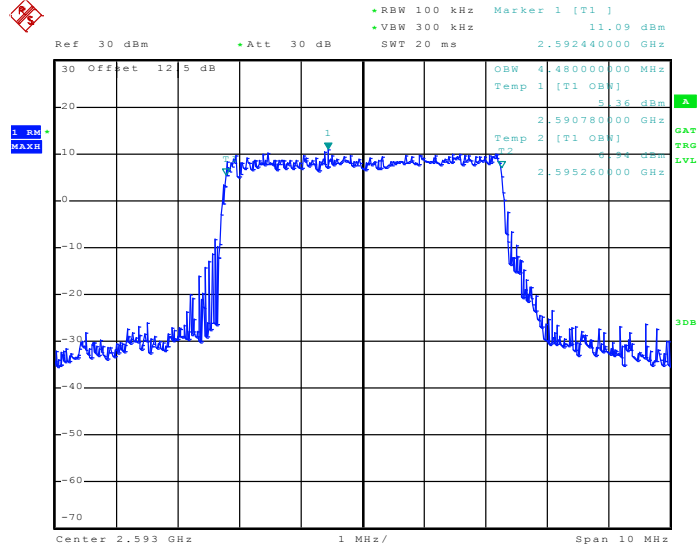

Date: 28.MAR.2011 17:32:35

**26dB Bandwidth Plot on Middle Channel**

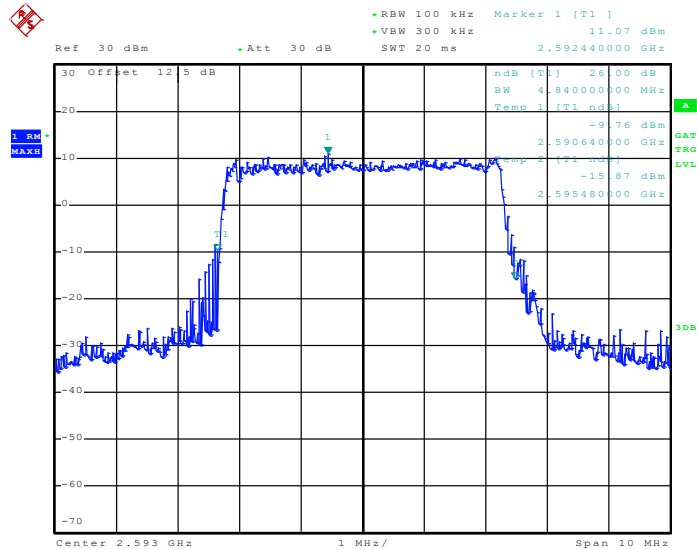

Date: 28.MAR.2011 17:35:46



Band :	802.16e	Power Stage :	High
Test Mode :	16QAM, BW 10MHz		

99% Occupied Bandwidth Plot on Middle Channel

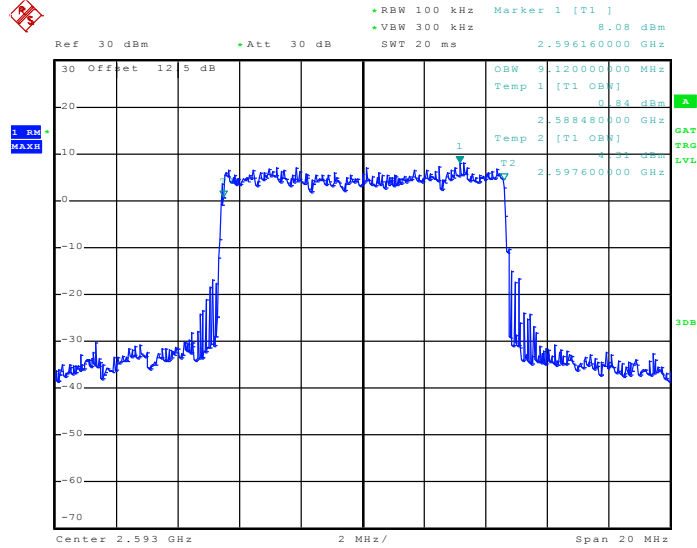

Date: 28.MAR.2011 16:44:36

26dB Bandwidth Plot on Middle Channel

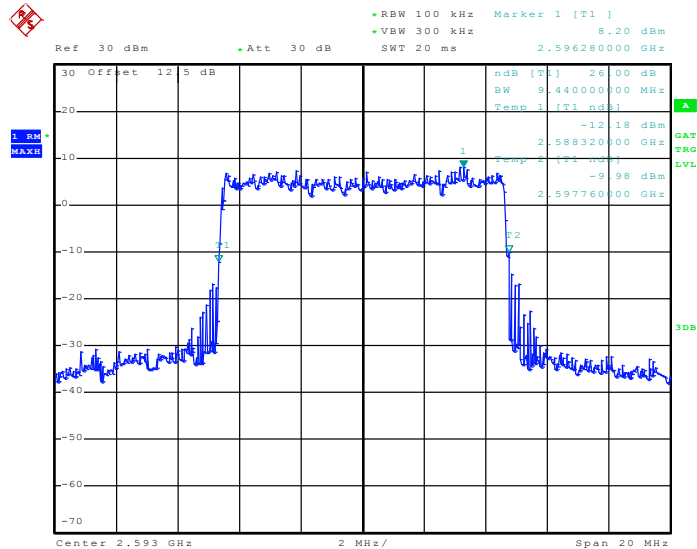

Date: 28.MAR.2011 16:41:39

### 3.3 Conducted Spurious Emission Measurement

#### 3.3.1 Description of Conducted Spurious Emission Measurement

The power of any emission outside of the authorized operating frequency ranges must be lower than the transmitter power (P) by a factor of mobile digital stations, the attenuation factor shall be not less than  $43 + 10 \log (P)$  dB at the channel edge and  $55 + 10 \log (P)$  dB at 5.5 MHz from the channel edges. It is measured by means of a calibrated spectrum analyzer and scanned from 30 MHz up to a frequency including its 10<sup>th</sup> harmonic.

#### 3.3.2 Measuring Instruments

See list of measuring instruments of this test report.

#### 3.3.3 Test Procedures

1. The EUT was connected to spectrum analyzer and System Simulator via power divider.
2. The conducted spurious emission for the whole frequency range was taken.

#### 3.3.4 Test Setup

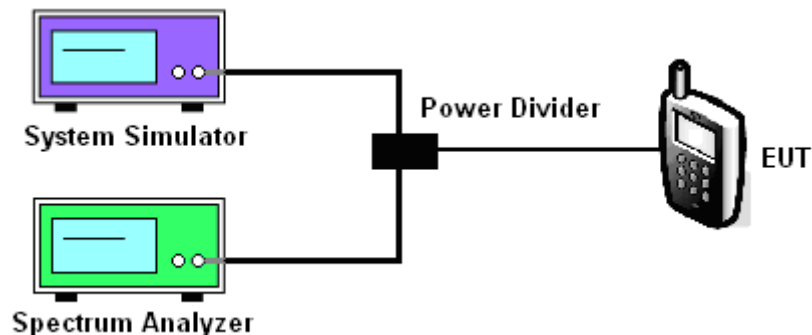



3.3.5 Test Plots of Spurious Emission

Band :	802.16e	Power Stage :	High
Test Mode :	QPSK, BW 5MHz	Channel :	Low

Conducted Spurious Emission Plot between 30MHz ~ 1GHz

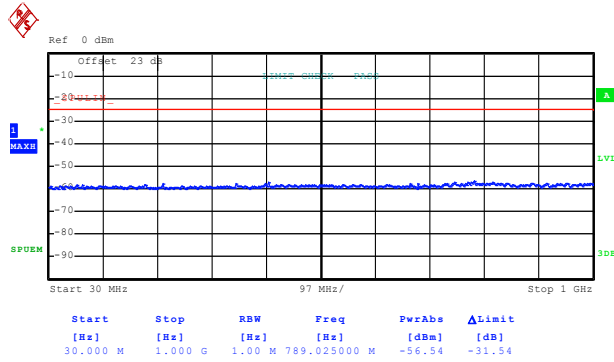

Date: 21.MAR.2011 17:50:41

Conducted Spurious Emission Plot between 1GHz ~ 27GHz

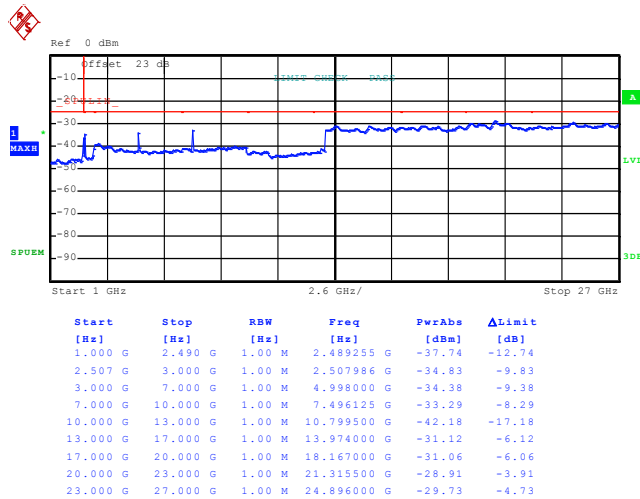

Date: 21.MAR.2011 17:38:21





<b>Band :</b>	802.16e	<b>Power Stage :</b>	High
<b>Test Mode :</b>	QPSK, BW 5MHz	<b>Channel :</b>	Middle

**Conducted Spurious Emission Plot between 30MHz ~ 1GHz**

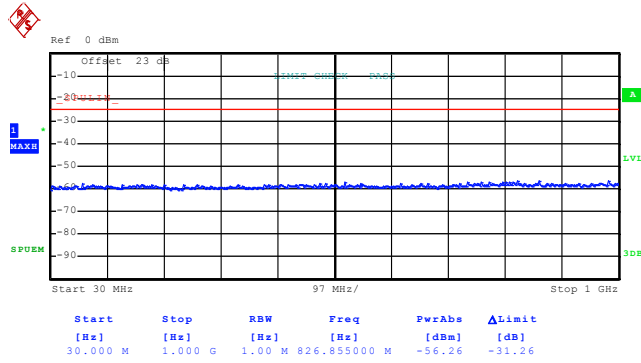

Date: 21.MAR.2011 17:53:04

**Conducted Spurious Emission Plot between 1GHz ~ 27GHz**

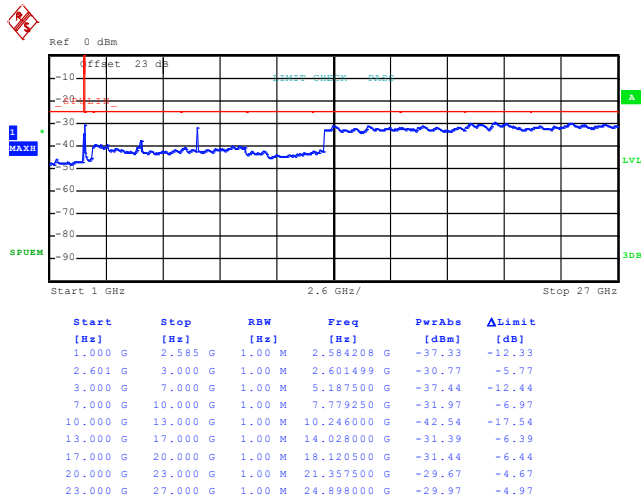

Date: 21.MAR.2011 17:35:40



<b>Band :</b>	802.16e	<b>Power Stage :</b>	High
<b>Test Mode :</b>	QPSK, BW 5MHz	<b>Channel :</b>	High

**Conducted Spurious Emission Plot between 30MHz ~ 1GHz**

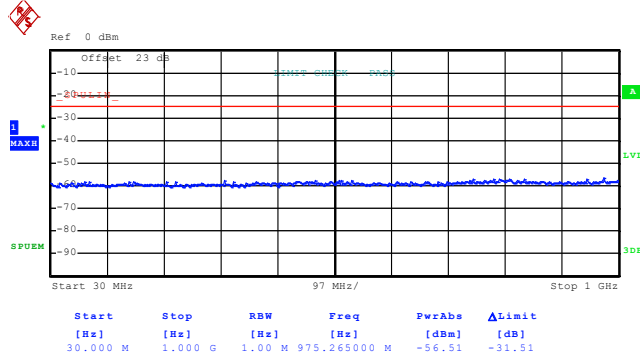

Date: 21.MAR.2011 17:54:52

**Conducted Spurious Emission Plot between 1GHz ~ 27GHz**

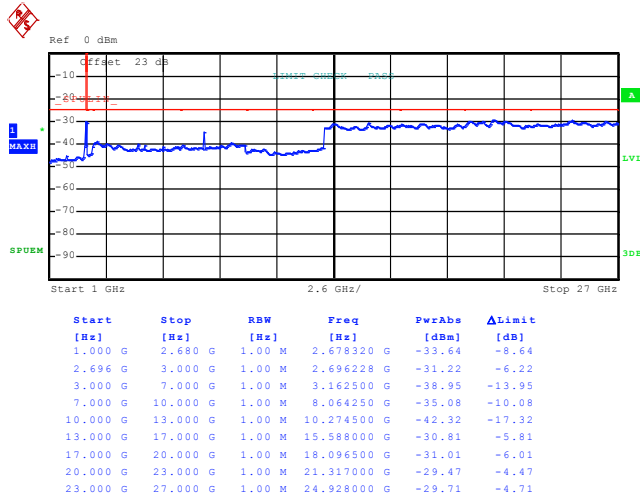

Date: 21.MAR.2011 17:23:23



<b>Band :</b>	802.16e	<b>Power Stage :</b>	High
<b>Test Mode :</b>	QPSK, BW 10MHz	<b>Channel :</b>	Low

**Conducted Spurious Emission Plot between 30MHz ~ 1GHz**

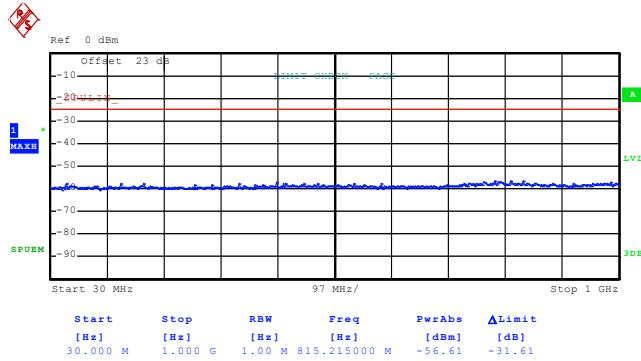

Date: 21.MAR.2011 17:51:07

**Conducted Spurious Emission Plot between 1GHz ~ 27GHz**

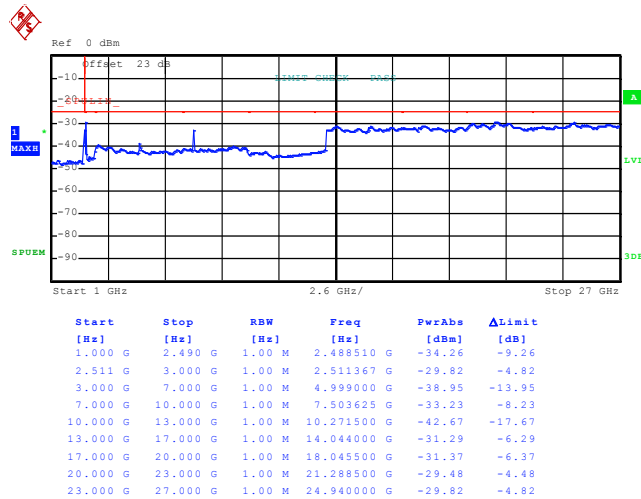

Date: 21.MAR.2011 17:00:34



<b>Band :</b>	802.16e	<b>Power Stage :</b>	High
<b>Test Mode :</b>	QPSK, BW 10MHz	<b>Channel :</b>	Middle

**Conducted Spurious Emission Plot between 30MHz ~ 1GHz**

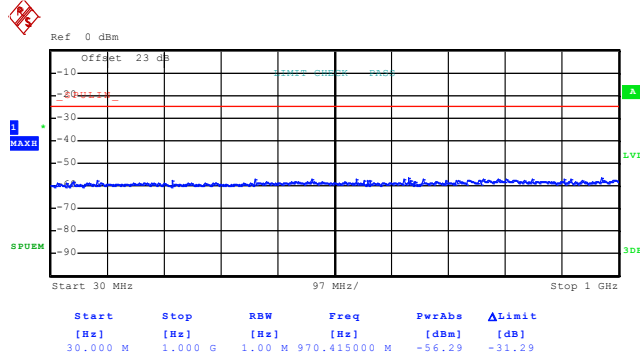

Date: 21.MAR.2011 17:53:29

**Conducted Spurious Emission Plot between 1GHz ~ 27GHz**

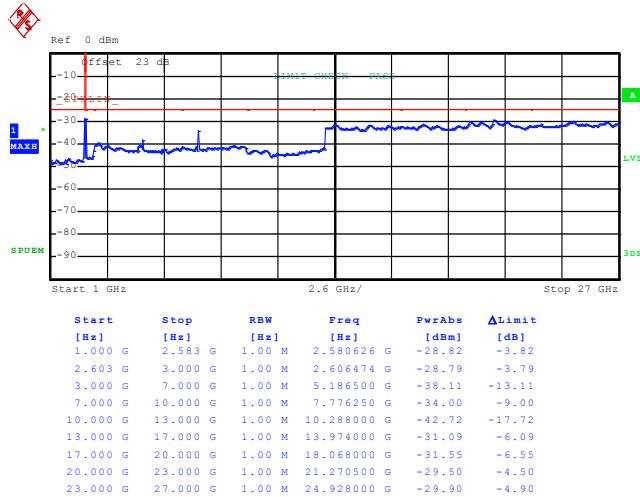

Date: 21.MAR.2011 17:11:38



<b>Band :</b>	802.16e	<b>Power Stage :</b>	High
<b>Test Mode :</b>	QPSK, BW 10MHz	<b>Channel :</b>	High

**Conducted Spurious Emission Plot between 30MHz ~ 1GHz**

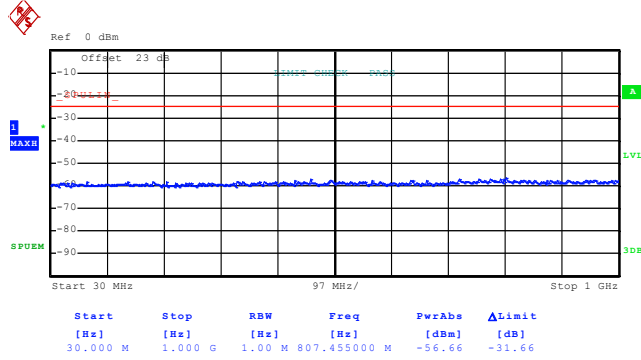

Date: 21.MAR.2011 17:54:33

**Conducted Spurious Emission Plot between 1GHz ~ 27GHz**

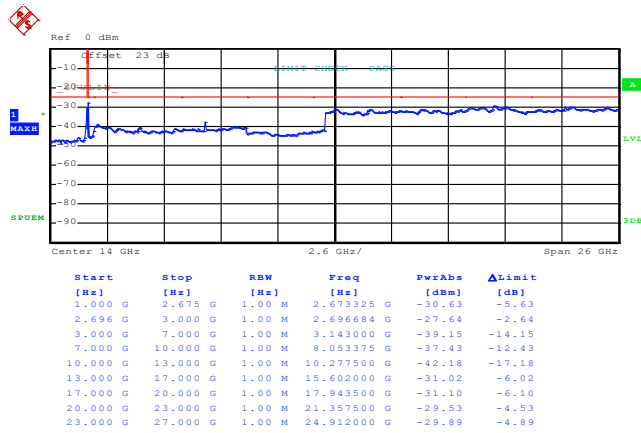

Date: 21.MAR.2011 17:18:42



<b>Band :</b>	802.16e	<b>Power Stage :</b>	High
<b>Test Mode :</b>	16QAM, BW 5MHz	<b>Channel :</b>	Low

**Conducted Spurious Emission Plot between 30MHz ~ 1GHz**

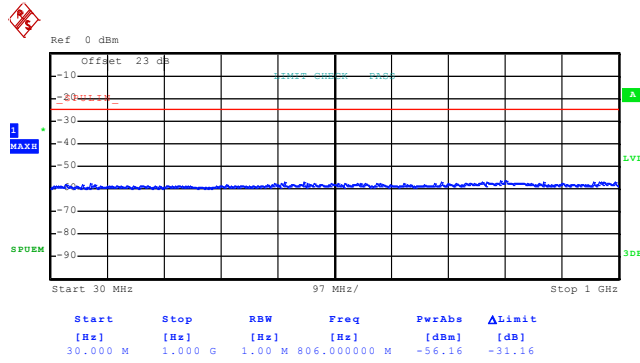

Date: 21.MAR.2011 17:50:13

**Conducted Spurious Emission Plot between 1GHz ~ 27GHz**

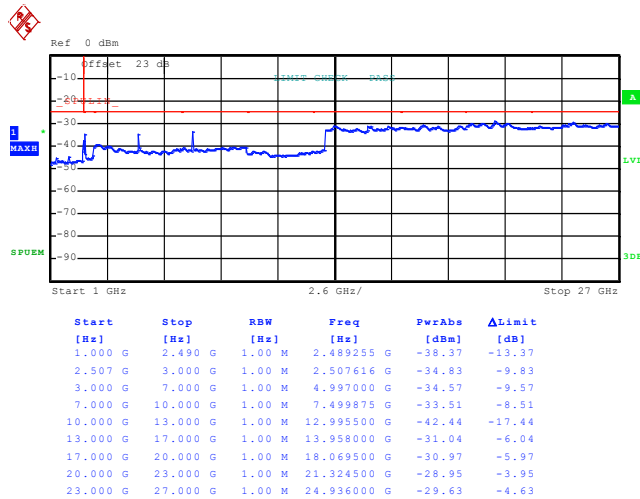

Date: 21.MAR.2011 17:40:05



<b>Band :</b>	802.16e	<b>Power Stage :</b>	High
<b>Test Mode :</b>	16QAM, BW 5MHz	<b>Channel :</b>	Middle

**Conducted Spurious Emission Plot between 30MHz ~ 1GHz**

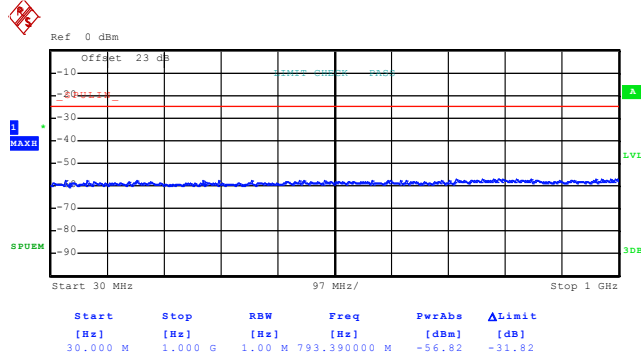

Date: 21.MAR.2011 17:52:39

**Conducted Spurious Emission Plot between 1GHz ~ 27GHz**

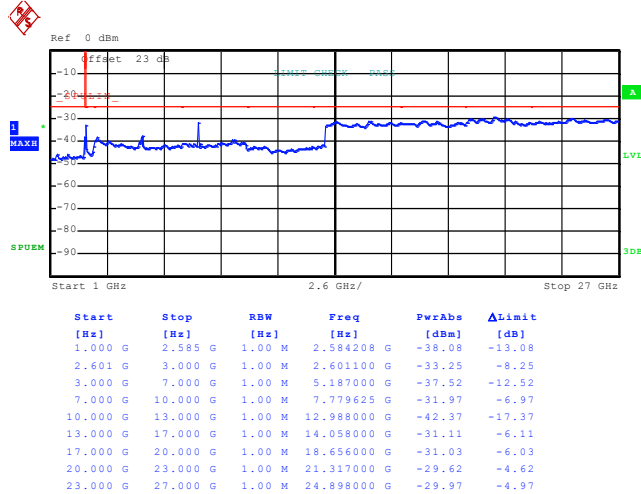

Date: 21.MAR.2011 17:33:04



<b>Band :</b>	802.16e	<b>Power Stage :</b>	High
<b>Test Mode :</b>	16QAM, BW 5MHz	<b>Channel :</b>	High

**Conducted Spurious Emission Plot between 30MHz ~ 1GHz**

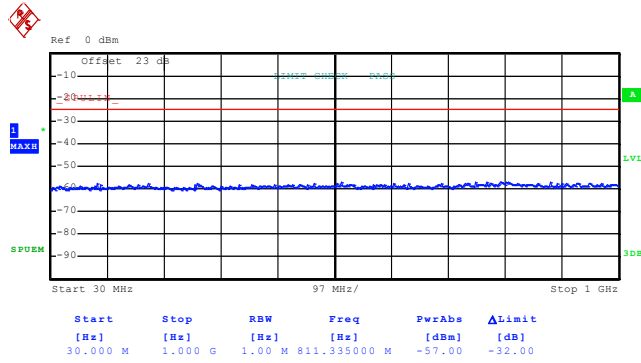

Date: 21.MAR.2011 17:55:13

**Conducted Spurious Emission Plot between 1GHz ~ 27GHz**

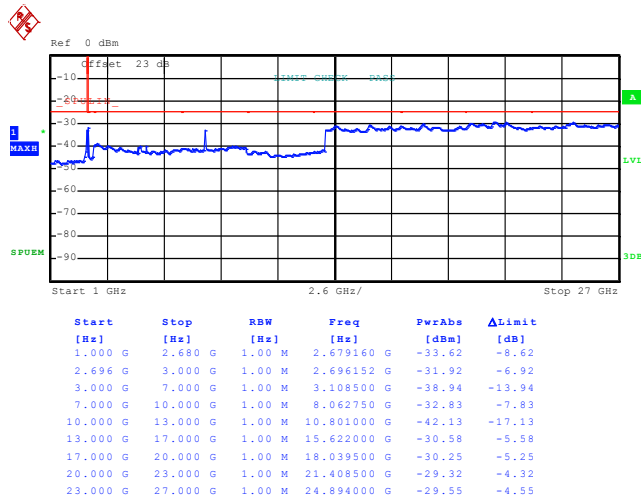

Date: 21.MAR.2011 17:30:07





Band :	802.16e	Power Stage :	High
Test Mode :	16QAM, BW 10MHz	Channel :	Low

Conducted Spurious Emission Plot between 30MHz ~ 1GHz

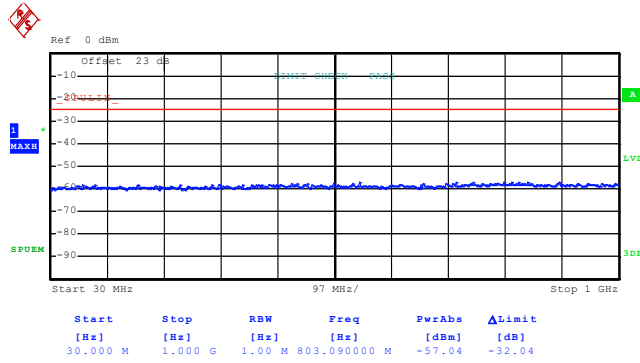

Date: 21.MAR.2011 17:51:32

Conducted Spurious Emission Plot between 1GHz ~ 27GHz

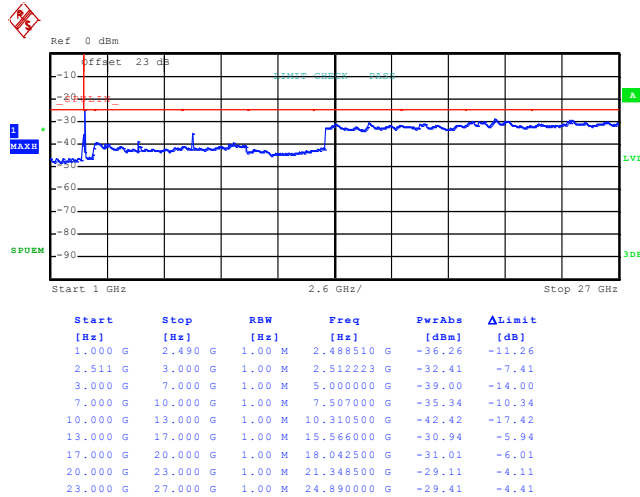

Date: 21.MAR.2011 17:04:41



<b>Band :</b>	802.16e	<b>Power Stage :</b>	High
<b>Test Mode :</b>	16QAM, BW 10MHz	<b>Channel :</b>	Middle

**Conducted Spurious Emission Plot between 30MHz ~ 1GHz**

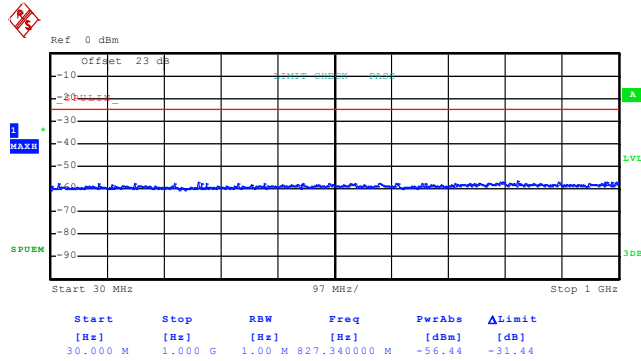

Date: 21.MAR.2011 17:53:49

**Conducted Spurious Emission Plot between 1GHz ~ 27GHz**

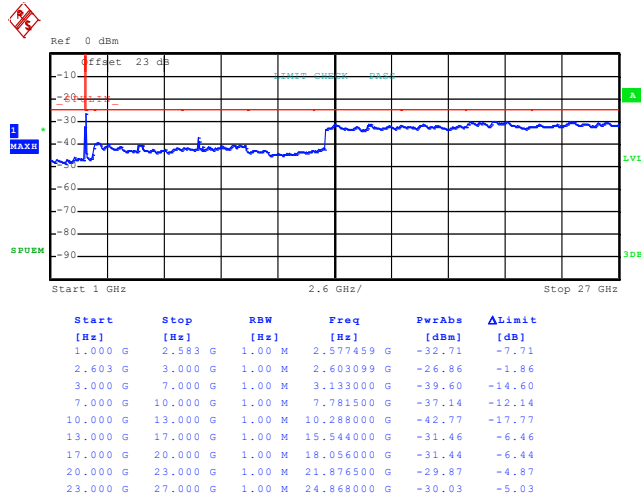

Date: 21.MAR.2011 17:10:16



<b>Band :</b>	802.16e	<b>Power Stage :</b>	High
<b>Test Mode :</b>	16QAM, BW 10MHz	<b>Channel :</b>	High

**Conducted Spurious Emission Plot between 30MHz ~ 1GHz**

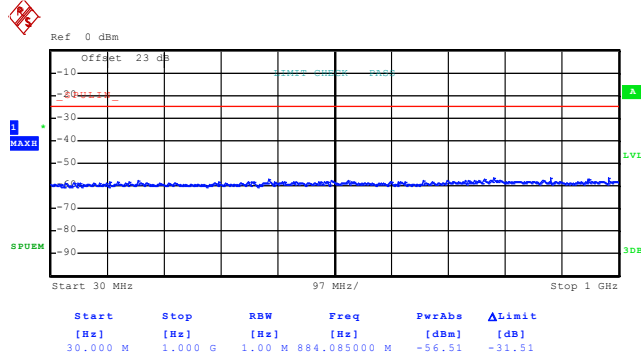

Date: 21.MAR.2011 17:54:10

**Conducted Spurious Emission Plot between 1GHz ~ 27GHz**

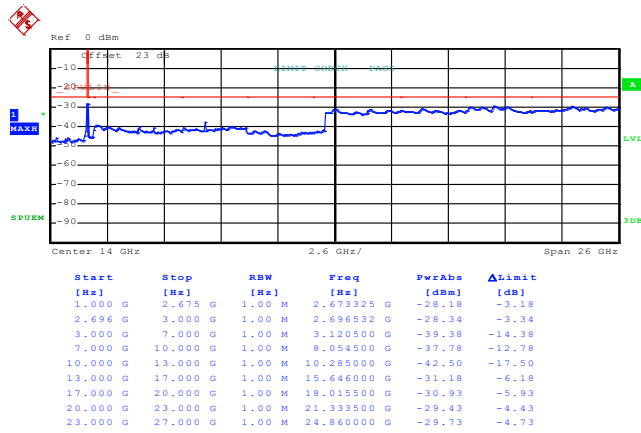

Date: 21.MAR.2011 17:17:46

## 3.4 Radiated Emissions Measurement

### 3.4.1 Description of Radiated Emissions Measurement

The power of any emission outside of the authorized operating frequency ranges must be lower than the transmitter power (P) by a factor of mobile digital stations, the attenuation factor shall be not less than  $43 + 10 \log (P)$  dB at the channel edge and  $55 + 10 \log (P)$  dB at 5.5 MHz from the channel edges. It is measured by means of a calibrated spectrum analyzer and scanned from 30 MHz up to a frequency including its 10<sup>th</sup> harmonic.

### 3.4.2 Measuring Instruments

See list of measuring instruments of this test report.

### 3.4.3 Test Procedures

1. The EUT was placed on a rotatable wooden table with 0.8 meter about ground.
2. The EUT was set 3 meters from the receiving antenna, which was mounted on the antenna tower.
3. The table was rotated 360 degrees to determine the position of the highest spurious emission.
4. The height of the receiving antenna is varied between one meter and four meters to search the maximum spurious emission for both horizontal and vertical polarizations.
5. Make the measurement with the spectrum analyzer's RBW = 1MHz, VBW = 1MHz, Sweep = 500ms, Taking the record of maximum spurious emission.
6. A horn antenna was substituted in place of the EUT and was driven by a signal generator.
7. Tune the output power of signal generator to the same emission level with EUT maximum spurious emission.
8. Taking the record of output power at antenna port.
9. Repeat step 7 to step 8 for another polarization.
10. Emission level (dBm) = output power + substitution Gain.

### 3.4.4 Test Setup

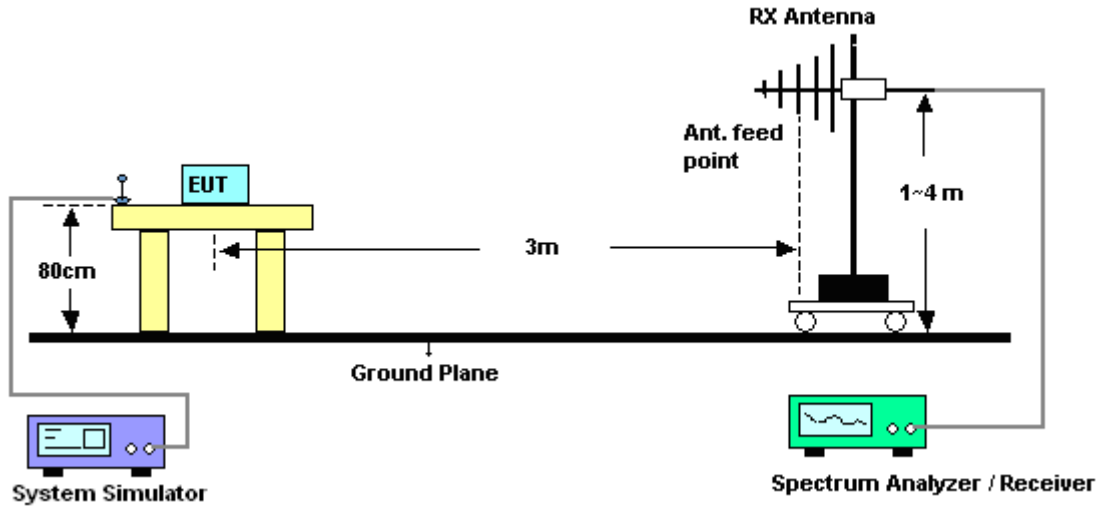



3.4.5 Test Result of Radiated Emissions

<b>Band :</b>	802.16e	<b>Temperature :</b>	21~22°C
<b>Test Mode :</b>	QPSK, BW 5MHz, Middle Ch (2593MHz)	<b>Relative Humidity :</b>	46~47%
<b>Test Engineer :</b>	Kai Wang	<b>Polarization :</b>	Horizontal
<b>Remark :</b>	Spurious emissions within 30-1000MHz were found more than 20dB below limit line.		

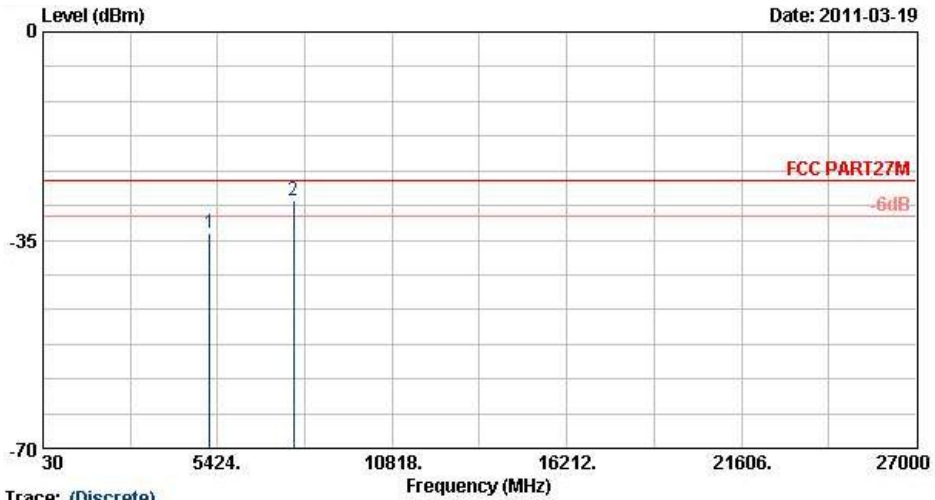

Trace: (Discrete)  
 Site : 08CH06-HY  
 Condition : FCC PART27M ETRP\_100524 HORIZONTAL  
 Project : FG 112033

Frequency ( MHz )	EIRP ( dBm )	Limit ( dBm )	Over Limit ( dB )	SPA Reading ( dBm )	S.G. Power ( dBm )	TX Cable loss ( dB )	TX Antenna Gain ( dBi )	Polarization ( H/V )	Result
5186	-33.87	-25	-8.87	-54.35	-42.75	1.29	10.17	H	Pass
7779	-28.33	-25	-3.33	-55.22	-38.82	1.63	12.12	H	Pass



<b>Band :</b>	802.16e	<b>Temperature :</b>	21~22°C
<b>Test Mode :</b>	QPSK, BW 5MHz, Middle Ch (2593MHz)	<b>Relative Humidity :</b>	46~47%
<b>Test Engineer :</b>	Kai Wang	<b>Polarization :</b>	Vertical
<b>Remark :</b>	Spurious emissions within 30-1000MHz were found more than 20dB below limit line.		

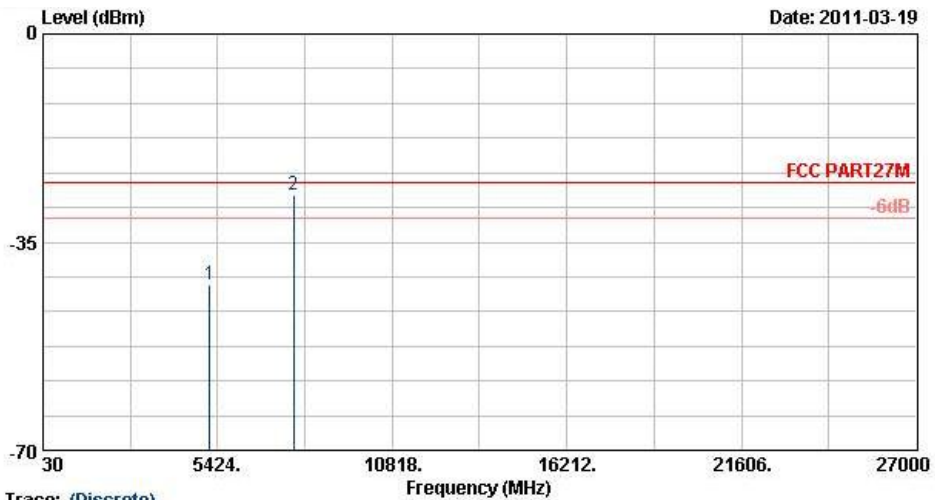

Trace: (Discrete)  
 Site : 03CH06-HY  
 Condition : FCC PART27M ETRP\_100524 VERTICAL  
 Project : FG 112033

Frequency (MHz)	EIRP (dBm)	Limit (dBm)	Over Limit (dB)	SPA Reading (dBm)	S.G. Power (dBm)	TX Cable loss (dB)	TX Antenna Gain (dBi)	Polarization (H/V)	Result
5186	-42.15	-25	-17.15	-63.57	-51.03	1.29	10.17	V	Pass
7779	-27.19	-25	-2.19	-53.92	-37.68	1.63	12.12	V	Pass



<b>Band :</b>	802.16e	<b>Temperature :</b>	21~22°C
<b>Test Mode :</b>	QPSK, BW 10MHz, Middle Ch (2593MHz)	<b>Relative Humidity :</b>	46~47%
<b>Test Engineer :</b>	Kai Wang	<b>Polarization :</b>	Horizontal
<b>Remark :</b>	Spurious emissions within 30-1000MHz were found more than 20dB below limit line.		

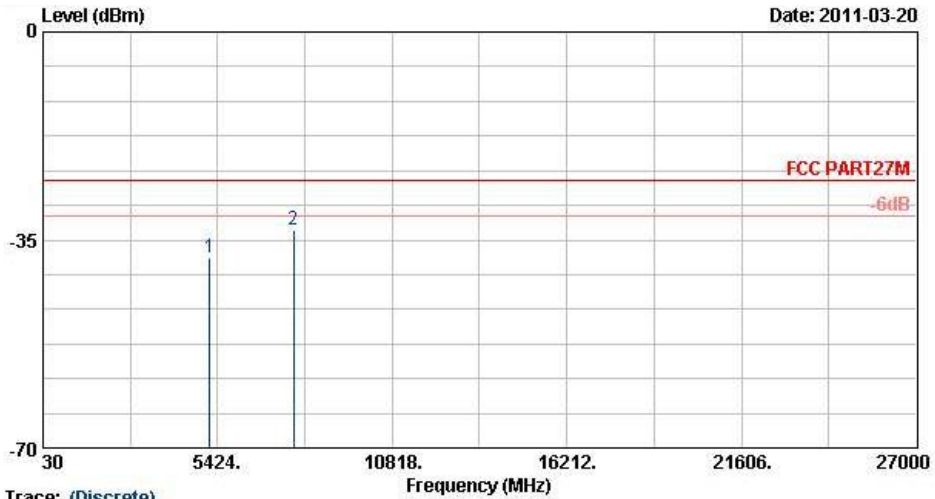

Trace: (Discrete)  
 Site : 08CH06-HY  
 Condition : FCC PART 27M ETRP\_100524 HORIZONTAL  
 Project : FG\_112033

Frequency ( MHz )	EIRP ( dBm )	Limit ( dBm )	Over Limit ( dB )	SPA Reading ( dBm )	S.G. Power ( dBm )	TX Cable loss ( dB )	TX Antenna Gain ( dBi )	Polarization ( H/V )	Result
5186	-37.98	-25	-12.98	-59.32	-46.86	1.29	10.17	H	Pass
7779	-33.22	-25	-8.22	-60.03	-43.71	1.63	12.12	H	Pass





<b>Band :</b>	802.16e	<b>Temperature :</b>	21~22°C
<b>Test Mode :</b>	QPSK, BW 10MHz, Middle Ch (2593MHz)	<b>Relative Humidity :</b>	46~47%
<b>Test Engineer :</b>	Kai Wang	<b>Polarization :</b>	Vertical
<b>Remark :</b>	Spurious emissions within 30-1000MHz were found more than 20dB below limit line.		

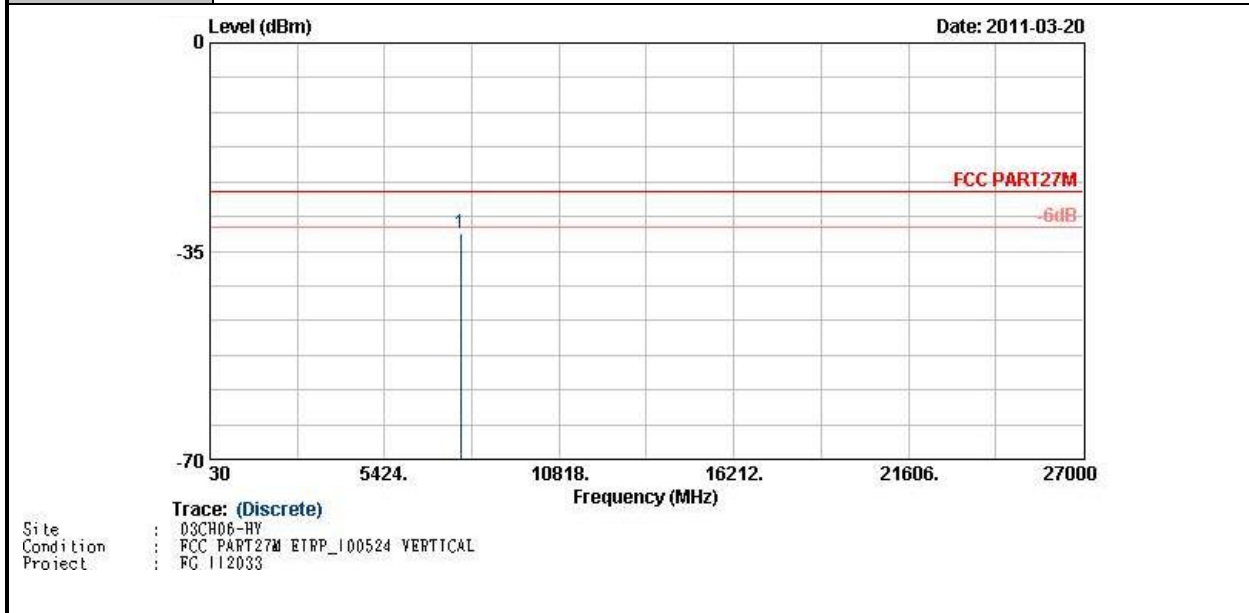

Frequency ( MHz )	EIRP ( dBm )	Limit ( dBm )	Over Limit ( dB )	SPA Reading ( dBm )	S.G. Power ( dBm )	TX Cable loss ( dB )	TX Antenna Gain ( dBi )	Polarization ( H/V )	Result
7779	-31.90	-25	-6.90	-58.77	-42.39	1.63	12.12	V	Pass



<b>Band :</b>	802.16e	<b>Temperature :</b>	21~22°C
<b>Test Mode :</b>	16QAM, BW 5MHz, Middle Ch (2593MHz)	<b>Relative Humidity :</b>	46~47%
<b>Test Engineer :</b>	Kai Wang	<b>Polarization :</b>	Horizontal
<b>Remark :</b>	Spurious emissions within 30-1000MHz were found more than 20dB below limit line.		

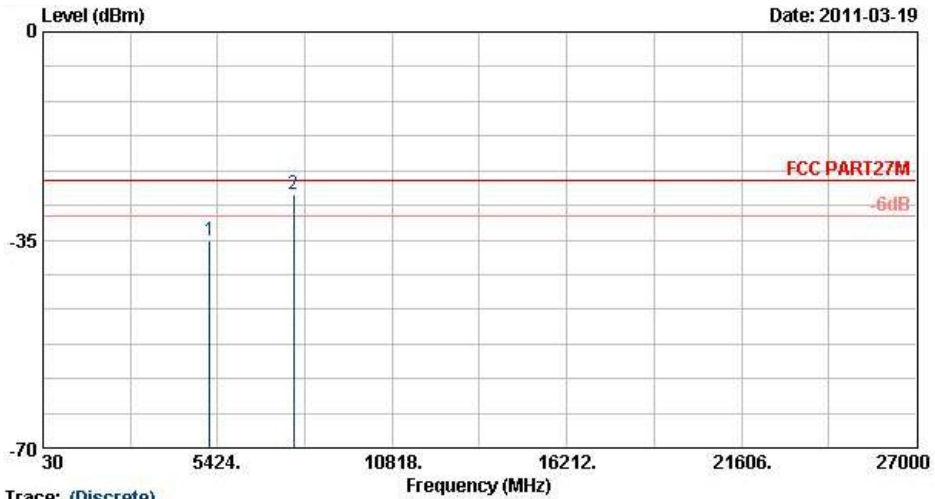

Trace: (Discrete)  
 Site : 08CH06-HY  
 Condition : FCC PART27M ETRP\_100524 HORIZONTAL  
 Project : FG\_112033

Frequency ( MHz )	EIRP ( dBm )	Limit ( dBm )	Over Limit ( dB )	SPA Reading ( dBm )	S.G. Power ( dBm )	TX Cable loss ( dB )	TX Antenna Gain ( dBi )	Polarization ( H/V )	Result
5186	-35.04	-25	-10.04	-56.57	-43.92	1.29	10.17	H	Pass
7779	-27.33	-25	-2.33	-54.21	-37.82	1.63	12.12	H	Pass



<b>Band :</b>	802.16e	<b>Temperature :</b>	21~22°C
<b>Test Mode :</b>	16QAM, BW 5MHz, Middle Ch (2593MHz)	<b>Relative Humidity :</b>	46~47%
<b>Test Engineer :</b>	Kai Wang	<b>Polarization :</b>	Vertical
<b>Remark :</b>	Spurious emissions within 30-1000MHz were found more than 20dB below limit line.		

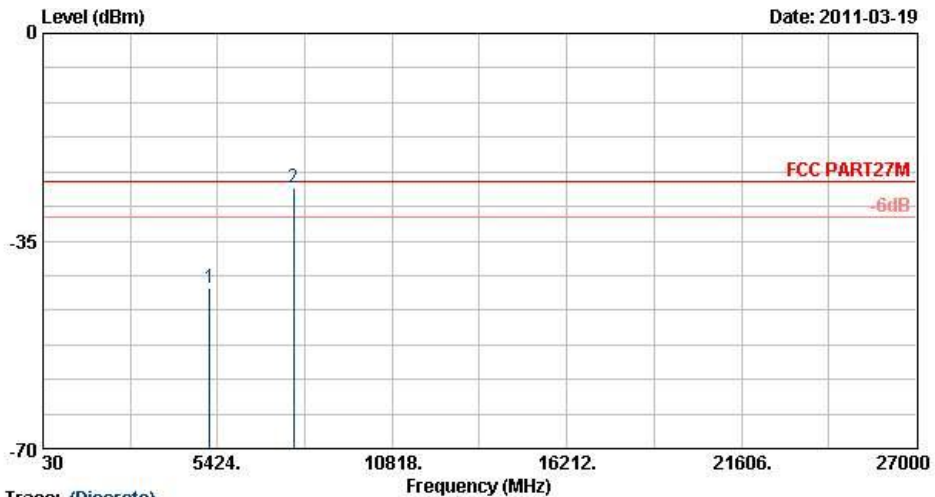

Trace: (Discrete)  
 Site : 03CH06-HY  
 Condition : FCC PART27M ETRP\_100524 VERTICAL  
 Project : FG 112033

Frequency ( MHz )	EIRP ( dBm )	Limit ( dBm )	Over Limit ( dB )	SPA Reading ( dBm )	S.G. Power ( dBm )	TX Cable loss ( dB )	TX Antenna Gain ( dBi )	Polarization ( H/V )	Result
5186	-42.84	-25	-17.84	-64.14	-51.72	1.29	10.17	V	Pass
7779	-25.93	-25	-0.93	-52.72	-36.42	1.63	12.12	V	Pass



<b>Band :</b>	802.16e	<b>Temperature :</b>	21~22°C
<b>Test Mode :</b>	16QAM, BW 10MHz, Middle Ch (2593MHz)	<b>Relative Humidity :</b>	46~47%
<b>Test Engineer :</b>	Kai Wang	<b>Polarization :</b>	Horizontal
<b>Remark :</b>	Spurious emissions within 30-1000MHz were found more than 20dB below limit line.		

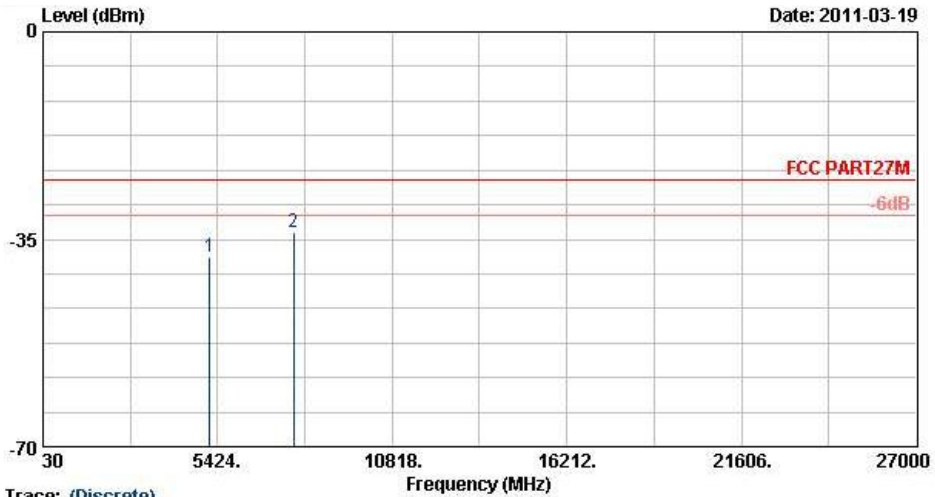

Trace: (Discrete)  
 Site : 03CH06-HY  
 Condition : FCC PART 27M ETRP\_100524 HORIZONTAL  
 Project : FG 112033

Frequency ( MHz )	EIRP ( dBm )	Limit ( dBm )	Over Limit ( dB )	SPA Reading ( dBm )	S.G. Power ( dBm )	TX Cable loss ( dB )	TX Antenna Gain ( dBi )	Polarization ( H/V )	Result
5186	-37.87	-25	-12.87	-59.12	-46.75	1.29	10.17	H	Pass
7779	-33.79	-25	-8.79	-60.46	-44.28	1.63	12.12	H	Pass



<b>Band :</b>	802.16e	<b>Temperature :</b>	21~22°C
<b>Test Mode :</b>	16QAM, BW 10MHz, Middle Ch (2593MHz)	<b>Relative Humidity :</b>	46~47%
<b>Test Engineer :</b>	Kai Wang	<b>Polarization :</b>	Vertical
<b>Remark :</b>	Spurious emissions within 30-1000MHz were found more than 20dB below limit line.		

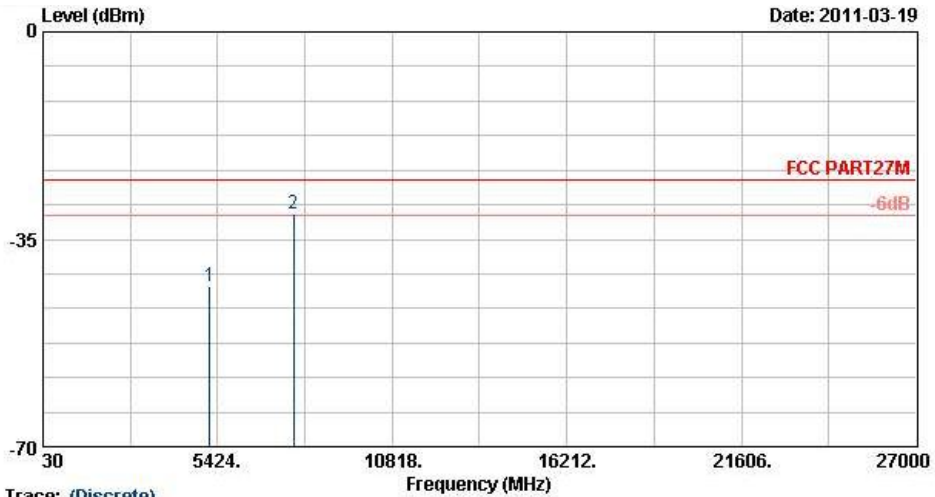

Trace: (Discrete)  
 Site : 03CH06-HY  
 Condition : FCC PART27M ETRP\_100524 VERTICAL  
 Project : FG 112033

Frequency ( MHz )	EIRP ( dBm )	Limit ( dBm )	Over Limit ( dB )	SPA Reading ( dBm )	S.G. Power ( dBm )	TX Cable loss ( dB )	TX Antenna Gain ( dBi )	Polarization ( H/V )	Result
5186	-42.93	-25	-17.93	-64.13	-51.81	1.29	10.17	V	Pass
7779	-30.80	-25	-5.80	-57.33	-41.29	1.63	12.12	V	Pass

## 3.5 Frequency Stability Measurement

### 3.5.1 Description of Frequency Stability Measurement

The frequency stability shall be sufficient to ensure that the fundamental emissions stay within the authorized frequency band. For equipment authorization purposes, this is a reporting requirement only.

### 3.5.2 Measuring Instruments

See list of measuring instruments of this test report.

### 3.5.3 Test Procedures for Temperature Variation

1. The EUT was set up in the thermal chamber and connected with the System Simulator.
2. With power OFF, the temperature was decreased to  $-30^{\circ}\text{C}$  and the EUT was stabilized for three hours. Power was applied and the maximum change in frequency was recorded within one minute.
3. With power OFF, the temperature was raised in  $10^{\circ}\text{C}$  step up to  $50^{\circ}\text{C}$ . The EUT was stabilized at each step for at least half an hour. Power was applied and the maximum frequency change was recorded within one minute.
4. If the EUT can not be turned on at  $-30^{\circ}\text{C}$ , the testing lowest temperature will be raised in  $10^{\circ}\text{C}$  step until the EUT can be turned on.

### 3.5.4 Test Procedures for Voltage Variation

1. The EUT was placed in a temperature chamber at  $25\pm 5^{\circ}\text{C}$  and connected with the System Simulator.
2. The power supply voltage to the EUT was varied from BEP to 115% of the nominal value measured at the input to the EUT.
3. The variation in frequency was measured for the worst case.

### 3.5.5 Test Setup

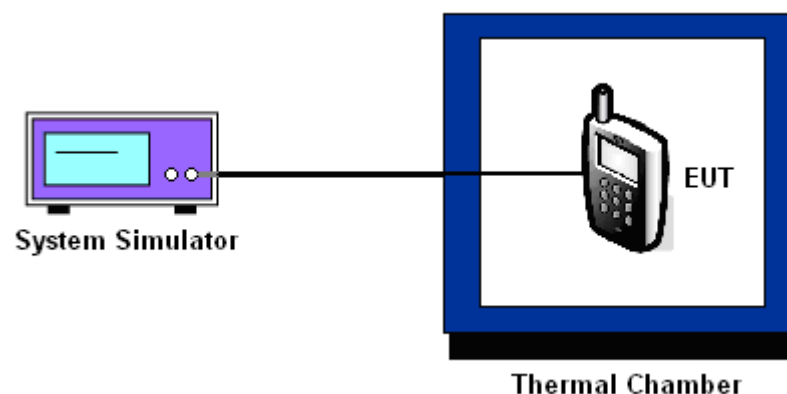



3.5.6 Test Result of Temperature Variation

<b>Band :</b>	802.16e	<b>Channel :</b>	Middle (2593MHz)
<b>Limit (ppm) :</b>	2.5		

Temperature (°C)	QPSK, BW 5MHz		QPSK, BW 10MHz		Result
	Freq. Dev. (Hz)	Deviation (ppm)	Freq. Dev. (Hz)	Deviation (ppm)	
-30	77.41	0.03	87.85	0.03	PASS
-20	82.35	0.03	80.53	0.03	
-10	64.23	0.02	86.93	0.03	
0	74.54	0.03	95.88	0.04	
10	76.29	0.03	81.49	0.03	
20	67.72	0.03	80.09	0.03	
30	77.16	0.03	83.02	0.03	
40	73.10	0.03	83.56	0.03	
50	82.40	0.03	78.22	0.03	

<b>Band :</b>	802.16e	<b>Channel :</b>	Middle (2593MHz)
<b>Limit (ppm) :</b>	2.5		

Temperature (°C)	16QAM, BW 5MHz		16QAM, BW 10MHz		Result
	Freq. Dev. (Hz)	Deviation (ppm)	Freq. Dev. (Hz)	Deviation (ppm)	
-30	79.45	0.03	80.63	0.03	PASS
-20	87.28	0.03	68.57	0.03	
-10	74.09	0.03	80.92	0.03	
0	69.50	0.03	77.36	0.03	
10	76.96	0.03	76.48	0.03	
20	93.46	0.04	67.76	0.03	
30	87.09	0.03	77.72	0.03	
40	90.35	0.03	85.08	0.03	
50	80.96	0.03	71.82	0.03	



3.5.7 Test Result of Voltage Variation

Band & Channel	Mode	Voltage (Volt)	Freq. Dev. (Hz)	Deviation (ppm)	Result
802.16e Middle (2593MHz)	QPSK, BW 5MHz	3.8	88.61	0.03	PASS
		BEP	90.00	0.03	
		4.2	79.01	0.03	
	QPSK, BW 10MHz	3.8	75.98	0.03	PASS
		BEP	83.22	0.03	
		4.2	68.44	0.03	
	16QAM, BW 5MHz	3.8	82.74	0.03	PASS
		BEP	80.89	0.03	
		4.2	78.80	0.03	
	16QAM, BW 10MHz	3.8	75.85	0.03	PASS
		BEP	85.15	0.03	
		4.2	78.92	0.03	

Note:

1. Normal Voltage = 3.8V.
2. Battery End Point (BEP) = 3.6 V.



## 4 List of Measuring Equipments

Instrument	Manufacturer	Model No.	Serial No.	Characteristics	Calibration Date	Due Date	Remark
System Simulator	R&S	CMU200	117995	N/A	Jun. 08, 2009	Jun. 07, 2011	Conducted (TH02-HY)
Spectrum Analyzer	R&S	FSP40	100055	9kHz~40GHz	Jun. 11, 2010	Jun. 10, 2011	Conducted (TH02-HY)
Power Meter	Anritsu	ML2495A	0932001	N/A	Sep. 13, 2010	Sep. 12, 2011	Conducted (TH02-HY)
Power Sensor	Anritsu	MA2411B	0846202	N/A	Sep. 14, 2010	Sep. 13, 2011	Conducted (TH02-HY)
Thermal Chamber	Ten Billion	TTH-D35P	TBN-930701	N/A	Jul. 30,2010	Jul. 29, 2011	Conducted (TH02-HY)
Spectrum Analyzer	R&S	FSP40	100057	9KHz-40GHz	Oct. 25, 2010	Oct. 24, 2011	Radiation (03CH06-HY)
EMI Test Receiver	R&S	ESVS10	834468/003	20MHz-1000MHz	Apr. 28, 2010	Apr. 27, 2011	Radiation (03CH06-HY)
Bilog Antenna	SCHAFFNER	CBL6112B	2885	30MHz -2GHz	Oct. 31, 2010	Oct. 31, 2011	Radiation (03CH06-HY)
Double Ridge Horn Antenna	EMCO	3117	00066583	1GHz~18GHz	Aug. 02, 2010	Aug. 01, 2011	Radiation (03CH06-HY)
Double Ridge Horn Antenna	Training Research	AH-0801	95119	8GHz~18GHz	Oct. 20, 2010	Oct. 19, 2011	Radiation (03CH06-HY)
SHF-EHF Horn Antenna	SCHWARZBECK	BBHA 9170	BBHA917025 1	15GHz- 40GHz	Oct. 18, 2010	Oct. 17, 2011	Radiation (03CH06-HY)
Pre Amplifier	Agilent	8449B	3008A01917	1GHz- 26.5GHz	Apr. 15, 2010	Apr. 14, 2011	Radiation (03CH06-HY)
Amplifier	Agilent	310N	186713	9KHz~1GHz	Apr. 15, 2010	Apr. 14, 2011	Radiation (03CH06-HY)
Loop Antenna	R&S	HFH2-Z2	860004/001	9 kHz~30 MHz	Jul. 29, 2010	Jul. 28, 2011	Radiation (03CH06-HY)
WiMAX Base Station (System Simulator)	Agilent	E6651A	N/A	N/A	N/A	N/A	Radiation (03CH06-HY)

## 5 Uncertainty of Evaluation

### Uncertainty of Radiated Emission Measurement (30 MHz ~ 1000 MHz)

Contribution	Uncertainty of $X_i$		$u(X_i)$
	dB	Probability Distribution	
Receiver Reading	0.41	Normal (k=2)	0.21
Antenna Factor Calibration	0.83	Normal (k=2)	0.42
Cable Loss Calibration	0.25	Normal (k=2)	0.13
Pre-Amplifier Gain Calibration	0.27	Normal (k=2)	0.14
RCV/SPA Specification	2.50	Rectangular	0.72
Antenna Factor Interpolation for Frequency	1.00	Rectangular	0.29
Site Imperfection	1.43	Rectangular	0.83
Mismatch	+0.39 / -0.41	U-Shape	0.28
<b>Combined Standard Uncertainty <math>U_c(y)</math></b>	<b>1.27</b>		
<b>Measuring Uncertainty for a Level of Confidence of 95% (<math>U = 2U_c(y)</math>)</b>	<b>2.54</b>		

### Uncertainty of Radiated Emission Measurement (1 GHz ~ 40 GHz)

Contribution	Uncertainty of $X_i$		$u(X_i)$	$C_i$	$C_i * u(X_i)$
	dB	Probability Distribution			
Receiver Reading	$\pm 0.10$	Normal (k=2)	0.10	1	0.10
Antenna Factor Calibration	$\pm 1.70$	Normal (k=2)	0.85	1	0.85
Cable Loss Calibration	$\pm 0.50$	Normal (k=2)	0.25	1	0.25
Receiver Correction	$\pm 2.00$	Rectangular	1.15	1	1.15
Antenna Factor Directional	$\pm 1.50$	Rectangular	0.87	1	0.87
Site Imperfection	$\pm 2.80$	Triangular	1.14	1	1.14
Mismatch Receiver VSWR $\Gamma_1 = 0.197$ Antenna VSWR $\Gamma_2 = 0.194$ Uncertainty = $20\text{Log}(1-\Gamma_1*\Gamma_2)$	+0.34 / -0.35	U-Shape	0.244	1	0.244
<b>Combined Standard Uncertainty <math>U_c(y)</math></b>	<b>2.36</b>				
<b>Measuring Uncertainty for a Level of Confidence of 95% (<math>U = 2U_c(y)</math>)</b>	<b>4.72</b>				