

FCC 47 CFR PART 27 SUBPART L

Product Type : Smartphone
Applicant : HTC Corporation
Address : No. 23, Xinghua Rd., Taoyuan City, Taoyuan County 330,
Taiwan
Trade name : HTC
Model No. : PG76210
Test Specification : FCC 47 CFR PART 27 SUBPART L: Oct. 2010
ANSI/TIA-603-C-2004
Issue Date : Jul. 14, 2011

Issue by

A Test Lab Techno Corp.
No. 140-1, Changan Street, Bade City,
Taoyuan County 334, Taiwan R.O.C.
Tel : +86-3-2710188 / Fax : +86-3-2710190



Taiwan Accreditation Foundation accreditation number: 1330

Note: This report shall not be reproduced except in full, without the written approval of A Test Lab Techno Corp. This document may be altered or revised by A Test Lab Techno Corp. personnel only, and shall be noted in the revision section of the document. The client should not use it to claim product endorsement by TAF, or any government agencies. The test results in the report only apply to the tested sample.

Revision History

Rev.	Issue Date	Revisions	Revised By
00	Jul. 14, 2011	Initial Issue	

Verification of Compliance

Issued Date: 07/14/2011

Product Type : Smartphone
Applicant : HTC Corporation
Address : No. 23, Xinghua Rd., Taoyuan City, Taoyuan County 330,
Taiwan
Trade Name : HTC
Model No. : PG76210
FCC ID : NM8PG76210
EUT Rated Voltage : DC 5.0V, 1.0A
Test Voltage : 120 Vac / 60 Hz
Applicable : FCC 47 CFR PART 27 SUBPART L: Oct. 2010
Standard : ANSI/TIA-603-C-2004
Test Result : Complied
Performing Lab. : A Test Lab Techno Corp.

No. 140-1, Changan Street, Bade City,
Taoyuan County 334, Taiwan R.O.C.

Tel : +886-3-2710188 / Fax : +886-3-2710190

Taiwan Accreditation Foundation accreditation number:
1330



<http://www.atl-lab.com.tw/e-index.htm>

The above equipment was tested by A Test Lab Techno Corp. The test data, data evaluation, test procedures, and equipment configurations shown in this report were made in accordance with the procedures given in ANSI C63.4: 2009 and the energy emitted by the sample tested as described in this report is in compliance with the requirements of FCC Rules Part 27L.

The test results of this report relate only to the tested sample identified in this report

Approved By : 
(Manager) (Miller Lee)

Reviewed By : 
(Testing Engineer) (Gary Wu)

TABLE OF CONTENTS

1	General Information.....	6
1.1.	EUT Description.....	6
1.2.	Mode of Operation.....	7
1.3.	EUT Exercise Software.....	7
1.4.	Configuration of Test System Details.....	7
1.5.	Test Site Environment.....	7
1.6.	Summary of Test Result.....	8
2	RF Output Power Test.....	9
2.1.	Limit.....	9
2.2.	Test Instruments.....	9
2.3.	Test Setup.....	9
2.4.	Test Procedure.....	9
2.5.	Uncertainty.....	10
2.6.	Test Result.....	10
3	Effective Radiated Power / Equivalent Isotropic Radiated Power Test.....	12
3.1.	Limit.....	12
3.2.	Test Instruments.....	12
3.3.	Test Setup.....	13
3.4.	Test Procedure.....	14
3.5.	Uncertainty.....	14
3.6.	Test Result.....	15
4	Occupied Bandwidth Test.....	16
4.1.	Limit.....	16
4.2.	Test Instruments.....	16
4.3.	Setup.....	16
4.4.	Test Procedure.....	17
4.5.	Uncertainty.....	17
4.6.	Test Result.....	17
5	Conducted Emission Test.....	20
5.1.	Limit.....	20
5.2.	Test Instruments.....	20
5.3.	Setup.....	20
5.4.	Test Procedure.....	21
5.5.	Uncertainty.....	21
5.6.	Test Result.....	21

6	Field Strength of Spurious Radiation Test	37
6.1.	Limit	37
6.2.	Test Instruments.....	37
6.3.	Setup.....	37
6.4.	Test Procedure.....	38
6.5.	Uncertainty.....	38
6.6.	Test Result	39
7	Frequency Stability (Temperature Variation) Test	42
7.1.	Limit	42
7.2.	Test Instruments.....	42
7.3.	Setup.....	42
7.4.	Test Procedure.....	42
7.5.	Uncertainty.....	43
7.6.	Test Result	43
8	Frequency Stability (Voltage Variation) Test	44
8.1.	Limit	44
8.2.	Test Instruments.....	44
8.3.	Setup.....	44
8.4.	Test Procedure.....	44
8.5.	Uncertainty.....	44
8.6.	Test Result	45
9	AC Power Conducted Emissions Test	46
9.1.	Limit	46
9.2.	Test Instruments.....	46
9.3.	Setup.....	46
9.4.	Test Procedure.....	47
9.5.	Uncertainty.....	47
9.6.	Test Result	48

1 General Information

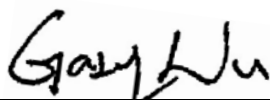
1.1. EUT Description

Applicant		HTC Corporation		
Applicant Address		No. 23, Xinghua Rd., Taoyuan City, Taoyuan County 330, Taiwan		
Manufacturer		HTC Corporation		
Manufacturer Address		No. 23, Xinghua Rd., Taoyuan City, Taoyuan County 330, Taiwan		
Product Type		Smartphone		
Trade Name		HTC		
Model Number		PG76210		
FCC ID		NM8PG76210		
Mode	AWS, 1xRTT, 1xEVDO Rev0, 1xEVDO RevA	UL Frequency (MHz)	DL Frequency (MHz)	Modulation
		1710 ~ 1755	2110 ~ 2155	QPSK
Type of Antenna		PIFA Type		
Antenna Gain (dBi)		1.7 dBi		
Max. RF Output Power		29.54 dBm / 0.899 W		
Max. EIRP		27.50 dBm / 0.562 W		
Emission Designator		1M29F9W		

1.2. Mode of Operation

ATL has verified the construction and function in typical operation. All the test modes were carried out with the EUT in normal operation, which was shown in this test report and defined as:

Test Mode
Mode 1: AWS Band Link
Mode 4: AWS 1xRTT Band Link
Mode 3: AWS 1xEVDO Rev0 Band Link
Mode 4: AWS 1xEVDO RevA Band Link

Note: Regards to the frequency band operation: the lowest, middle and highest frequency of channel were selected to perform the test, then shown on this report.

Tested System Details

The types for all equipments, plus descriptions of all cables used in the tested system (including inserted cards) are:

	Product	Manufacturer	Model No.	Serial No.	Power Cord
1.	Universal Radio Communication Tester	R&S	CMU200	109369	Non-shielded ,1.8m

1.3. EUT Exercise Software

1.	Setup the EUT and Base Station (CMU200) as shown on 1.4.
2.	Turn on the power of all equipment.

1.4. Configuration of Test System Details

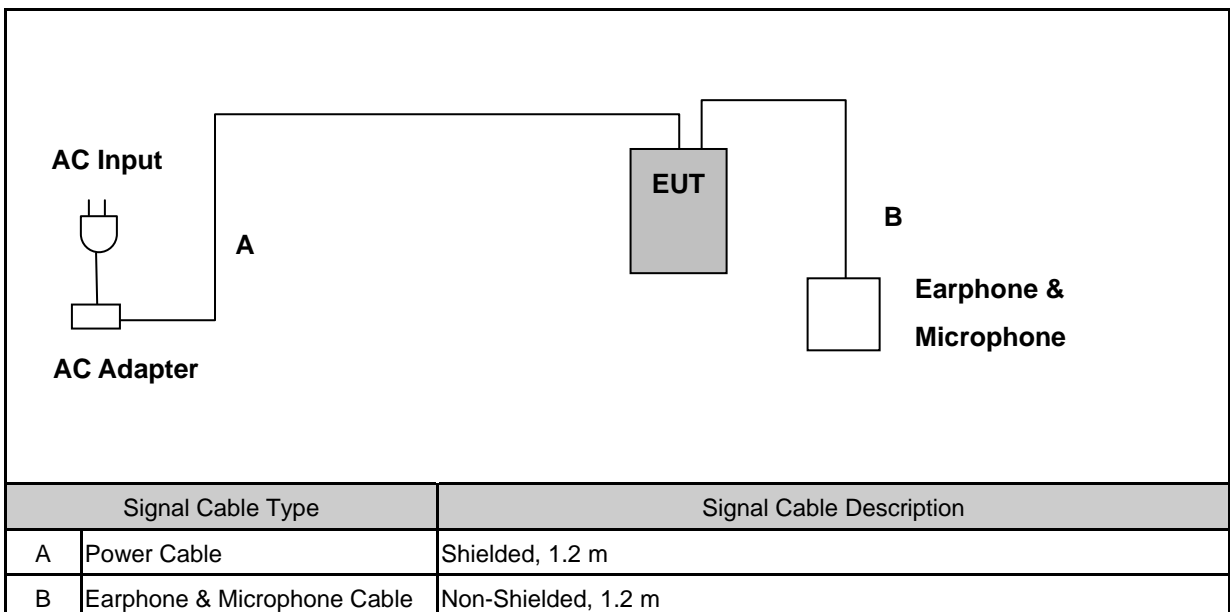

1.5. Test Site Environment

Items	Required (IEC 68-1)	Actual
Temperature (°C)	15-35	26
Humidity (%RH)	25-75	55
Barometric pressure (mbar)	860-1060	950

1.6. Summary of Test Result

Description	FCC Rule	IC Rule	Limit	Result
Conducted Output Power	§2.1046	N/A	N/A	Pass
Equivalent Isotropic Radiated Power	§27.50(d)(2)	RSS-139 (6.4) SRSP-513(5.1.2)	< 1 Watts	Pass
Occupied Bandwidth	§2.1049 §27.53(h)	N/A	N/A	Pass
Band Edge Measurement	§2.1051 §27.53(h)	RSS-139 (6.5)	< $43+10\log_{10}(P[\text{Watts}])$	Pass
Conducted Emission	§2.1051 §27.53(h)	RSS-139 (6.5)	< $43+10\log_{10}(P[\text{Watts}])$	Pass
Field Strength of Spurious Radiation	§2.1053 §27.53(h)	RSS-139 (6.5)	< $43+10\log_{10}(P[\text{Watts}])$	Pass
Frequency Stability for Temperature & Voltage	§2.1055 §27.54	RSS-139(6.3)	< 2.5 ppm	Pass

2 RF Output Power Test

2.1. Limit

N/A

2.2. Test Instruments

Describe	Manufacturer	Model No.	Serial No.	Cal. Date	Remark
Universal Radio Communication Tester	ROHDE & SCHWARZ	CMU200	109369	08/10/2010	(2)
Single Channel PK Power Sensor	Agilent	N1911A	MY45101619	07/19/2010	(2)
Wideband Power Meter	Agilent	N1921A	MY45241957	07/19/2010	(2)
Test Site	ATL	TE02	TE02	N.C.R.	-----

Remark: ⁽¹⁾ Calibration period 1 year. ⁽²⁾ Calibration period 2 years.

NOTE: N.C.R. = No Calibration Request.

2.3. Test Setup

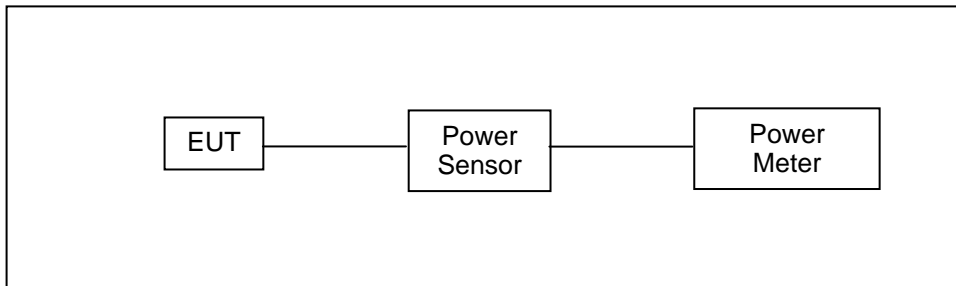

2.4. Test Procedure

The measurement is made according to ANSI/TIA-603-C-2004 as follows:

1. The transmitter output was connected to power meter and base station through power divider.
2. Set base station for EUT at AWS Band, power level was set to maximum.
3. Select lowest, middle, and highest channels for each band.

2.5. Uncertainty

The measurement uncertainty is defined as for RF output power measurement is 1.2 dB.

2.6. Test Result

Product	Smartphone						
Test Item	RF Output Power						
Mode	Mode 1						
Date of Test	06/23/2011			Test Site	TE05		
Band	RC/TAP (REV)	Frequency (MHz)	Average Power		Peak Power		
			(dBm)	(W)	(dBm)	(W)	
AWS Band	RC1/SO55	1711.25	23.66	0.232	24.02	0.252	
		1732.50	24.30	0.269	24.57	0.286	
		1753.75	23.77	0.238	24.12	0.258	
	RC3/SO55	1711.25	23.82	0.241	24.14	0.259	
		1732.50	24.35	0.272	24.59	0.288	
		1753.75	23.70	0.234	23.84	0.242	

Product	Smartphone						
Test Item	RF Output Power						
Mode	Mode 2						
Date of Test	06/23/2011			Test Site	TE05		
Band	RC/TAP (REV)	Frequency (MHz)	Average Power		Peak Power		
			(dBm)	(W)	(dBm)	(W)	
AWS 1xRTT Band	RC3/SO32	1711.25	23.78	0.239	24.08	0.256	
		1732.50	24.31	0.270	24.43	0.277	
		1753.75	23.93	0.247	24.41	0.276	

Product	Smartphone						
Test Item	RF Output Power						
Mode	Mode 3						
Date of Test	06/23/2011			Test Site	TE05		
Band	RTAP (kbps)	Frequency (MHz)	Average Power		Peak Power		
			(dBm)	(W)	(dBm)	(W)	
AWS 1xEVDO Rev0 Band	153.6	1711.25	23.38	0.218	29.40	0.871	
		1732.50	23.47	0.222	29.54	0.899	
		1753.75	23.29	0.213	29.38	0.867	

Note: The testing result was used peak detector.

Product	Smartphone						
Test Item	RF Output Power						
Mode	Mode 4						
Date of Test	06/23/2011			Test Site	TE05		
Band	RETAP Payload size	Frequency (MHz)	Average Power		Peak Power		
			(dBm)	(W)	(dBm)	(W)	
AWS 1xEVDO RevA Band	4096	1711.25	23.49	0.223	27.80	0.603	
		1732.50	23.64	0.231	28.30	0.676	
		1753.75	23.39	0.218	27.91	0.618	

Note: The testing result was used peak detector.

3 Effective Radiated Power / Equivalent Isotropic Radiated Power Test

3.1. Limit

For FCC Part 27.50(d)(2): The EIRP of mobile transmitters are limited to 1 watt for 1710~1755 MHz.

3.2. Test Instruments

3 Meter Chamber					
Equipment	Manufacturer	Model Number	Serial Number	Cal. Date	Remark
RF Pre-selector	Agilent	N9039A	MY46520256	01/18/2011	(2)
Spectrum Analyzer	Agilent	E4446A	MY46180578	01/18/2011	(1)
Pre Amplifier	Agilent	8449B	3008A02237	02/23/2011	(1)
Pre Amplifier	Agilent	8447D	2944A10961	02/23/2011	(1)
Bi-log Antenna	SCHWARZBECK MESS-ELEKTRONIK	VULB9163	9163-270	08/02/2010	(1)
Horn Antenna	SCHWARZBECK MESS-ELEKTRONIK	BBHA9120D	9120D-550	06/29/2010	(1)
Horn Antenna	SCHWARZBECK MESS-ELEKTRONIK	BBHA9170	9170-320	06/29/2010	(1)
Test Site	ATL	TE01	888001	07/30/2010	(1)

Remark: ⁽¹⁾ Calibration period 1 year. ⁽²⁾ Calibration period 2 years.

NOTE: N.C.R. = No Calibration Request.

3.3. Test Setup

Below 1 GHz

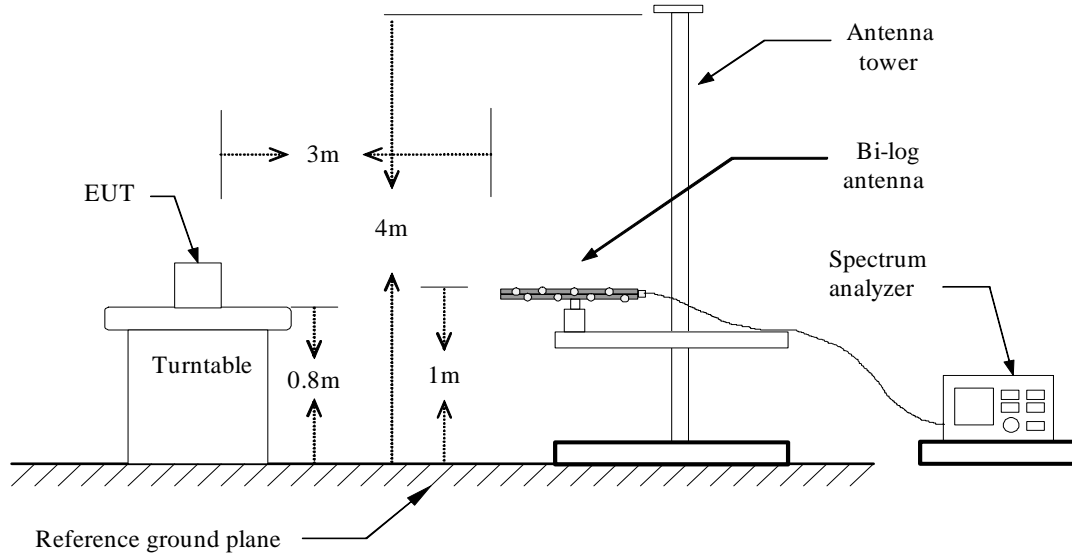

Above 1 GHz

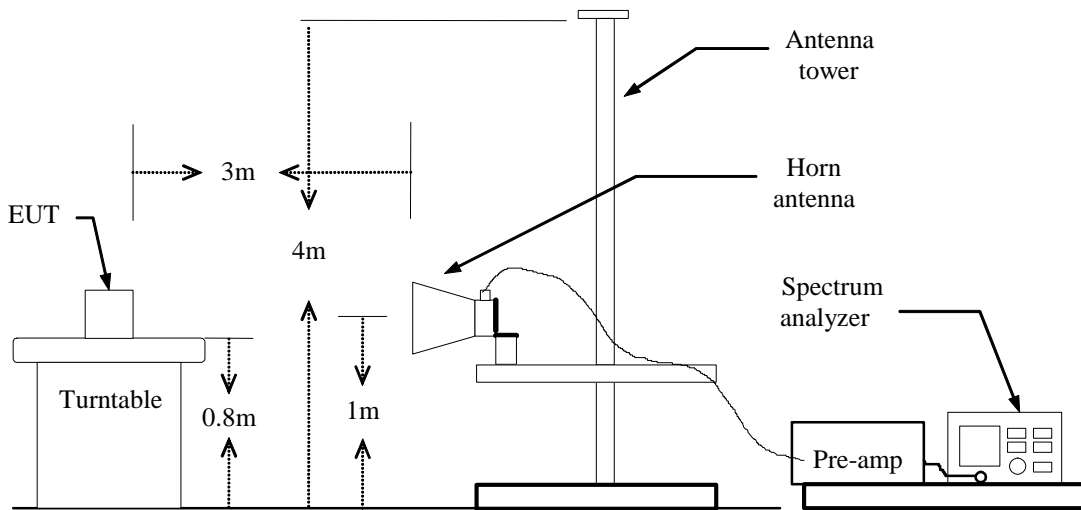

For Substituted Method Test Set-UP

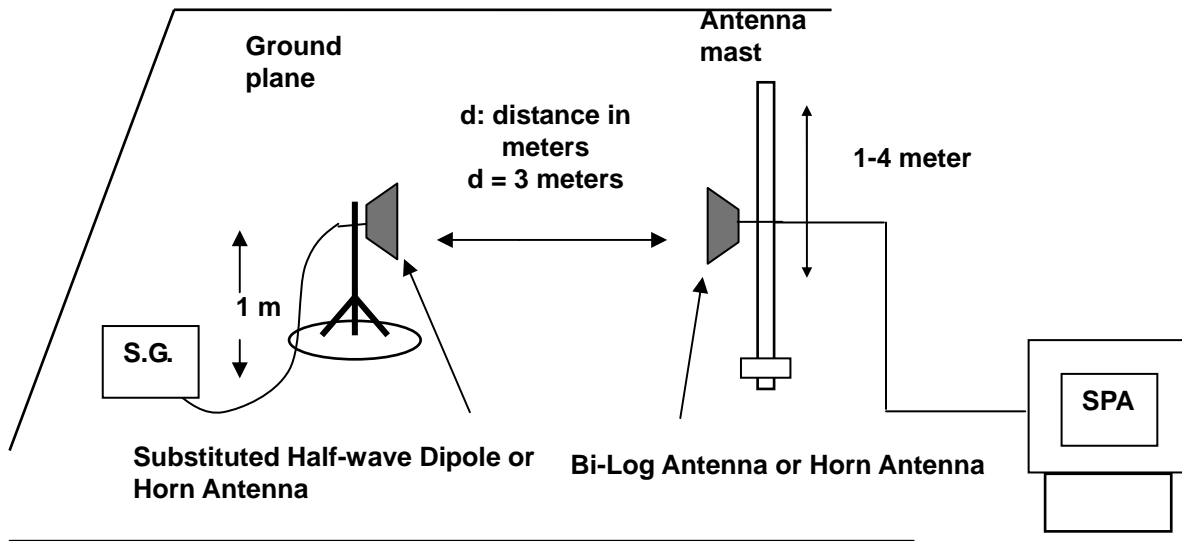

3.4. Test Procedure

The measurement is made according to ANSI/TIA-603-C-2004 as follows:

The EUT was placed on a non-conductive turntable using a non-conductive support. The radiated emission at the fundamental frequency was measured at 3 m with a test antenna and EMI spectrum analyzer.

During the measurement of the EUT, the resolution bandwidth was set to 5MHz and the average bandwidth was set to 5MHz. The highest emission was recorded with the rotation of the turntable and the lowering of the test antenna. The reading was recorded and the field strength (E in dBuV/m) was calculated.

EIRP in frequency band 1710 –1755MHz were measured using a substitution method. The EUT was replaced by horn antenna (1710-1755MHz) connected to a signal generator. The spectrum analyzer reading was recorded and ERP/EIRP was calculated as follows:

$$\text{EIRP} = \text{S.G. output (dBm)} + \text{Antenna Gain (dBi)} - \text{Cable (dB)}$$

3.5. Uncertainty

The measurement uncertainty is defined as for Field Strength of Spurious Radiation measurement is ± 3.072 dB.

3.6. Test Result

Model Number	PG76210						
Test Item	EIRP						
Date of Test	06/24/2011				Test Site		TC03
Mode	Frequency (MHz)	Ant. Polar.	Read Level (dBm)	Correction factor (dBm)	EIRP		Limit (W)
					(dBm)	(W)	
3	1711.25	H	16.00	10.40	26.40	0.437	< 1
		V	18.13	7.18	25.31	0.340	< 1
	1732.50	H	17.10	10.40	27.50	0.562	< 1
		V	18.24	7.34	25.58	0.361	< 1
	1753.75	H	16.72	10.40	27.12	0.515	< 1
		V	18.17	7.50	25.67	0.369	< 1

Note: 1. EIRP = Read Level + Correction factor.

2. For CDMA signals, a peak detector is used with RBW = VBW = 5MHz.

4 Occupied Bandwidth Test

4.1. Limit

The Occupied Bandwidth Limit:

N/A.

The Band Edge Limit:

The power of any emission outside of the authorized operating frequency ranges must be attenuated below the transmitting power (P) by a factor of at least $43 + 10\log(P)$ dB.

4.2. Test Instruments

Describe	Manufacturer	Model No.	Serial No.	Cal. Date	Remark
Spectrum Analyzer	Agilent	E4445A	MY46181986	05/16/2011	(2)
Universal Radio Communication Tester	ROHDE & SCHWARZ	CMU200	109369	08/10/2010	(2)
Attenuator	RADIALL	R41572000	0603033073	N.C.R.	-----
Power divider	Agilent	87302C	3239A00760	N.C.R.	-----
Test Site	ATL	TE05	TE05	N.C.R.	-----

Remark: ⁽¹⁾ Calibration period 1 year. ⁽²⁾ Calibration period 2 years.

NOTE: N.C.R. = No Calibration Request.

4.3. Setup

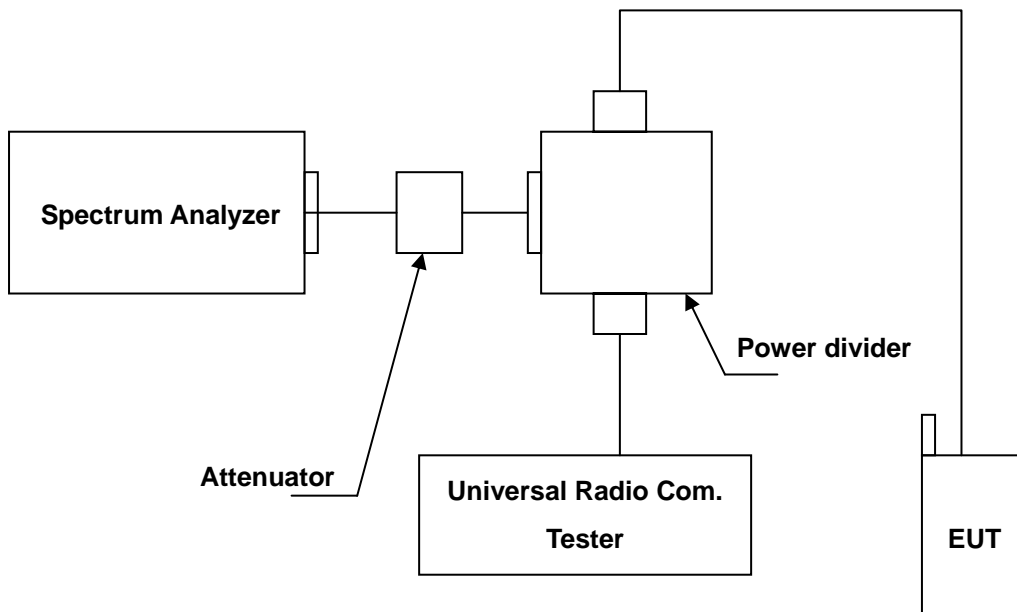

4.4. Test Procedure

The measurement is made according to FCC rules part 27:

1. The EUT was connected to Spectrum Analyzer and Base Station via power divider.
2. The occupied bandwidth of middle channel for the highest and lowest RF powers was measured.
3. The band edge of low and high channels for the highest RF powers within the transmitting frequency band were measured. Setting RBW as roughly BW/100.
4. The band edge setting:RB=47 kHz; VB=150 kHz for WCDMA Band IV.

4.5. Uncertainty

The measurement uncertainty is defined as $\pm 10\text{Hz}$

4.6. Test Result

99% Occupied Bandwidth

Product	Smartphone			
Test Item	Occupied Bandwidth			
Test Mode	Mode 3			
Date of Test	06/23/2011	Test Site	TE05	
Channel No.	Frequency (MHz)	99 % Bandwidth (MHz)	Limit	Note
25	1711.25	1.2792	N/A	RBW: 30kHz , VBW: 300kHz
450	1732.50	1.2924	N/A	RBW: 30kHz , VBW: 300kHz
875	1753.75	1.2792	N/A	RBW: 30kHz , VBW: 300kHz

99% Occupied Bandwidth

<p>CH 25</p>	
<p>CH 450</p>	
<p>CH 875</p>	

Band Edge

Product	Smartphone				
Test Item	Band Edge				
Test Mode	Mode 3				
Date of Test	06/23/2011		Test Site	TE02	
Band	Channel	Frequency (MHz)	Band Edge (dBm)	Limit (dBm)	Result
Lower	25	1711.25	-28.78	-13	Pass
Higher	875	1753.75	-29.98	-13	Pass

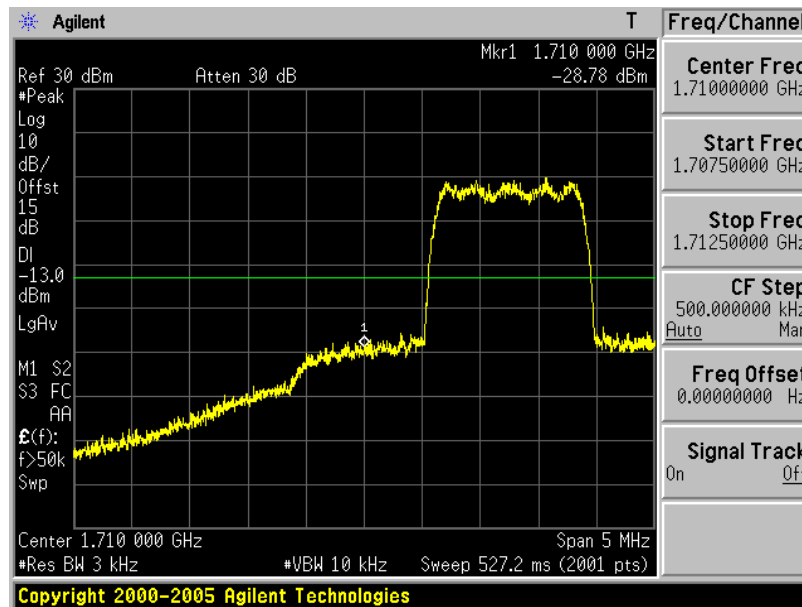
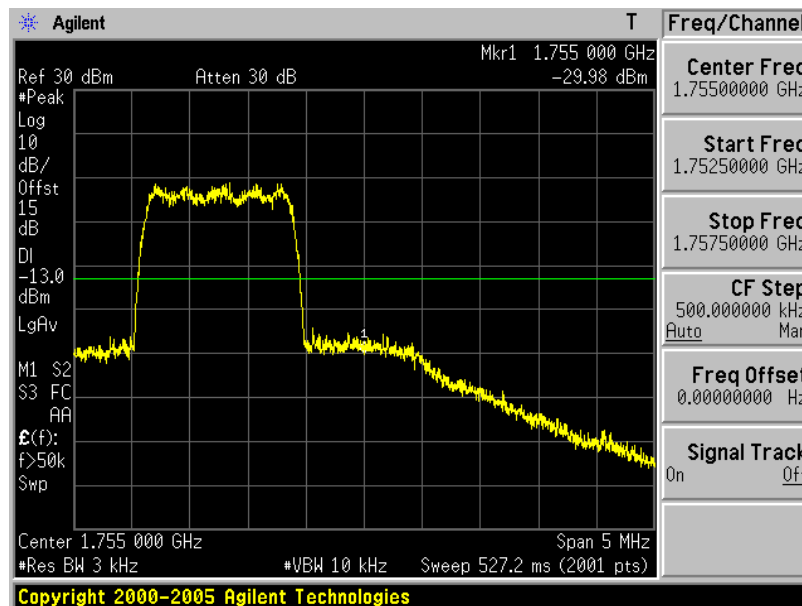
Lower Band

Higher Band

5 Conducted Emission Test

5.1. Limit

The power of any emission outside of the authorized operating frequency ranges must be attenuated below the transmitting power (P) by a factor of at least $43 + 10\log(P)$ dB.

5.2. Test Instruments

Describe	Manufacturer	Model No.	Serial No.	Cal. Date	Remark
Spectrum Analyzer	Agilent	E4445A	MY46181986	05/16/2011	(2)
Universal Radio Communication Tester	ROHDE & SCHWARZ	CMU200	109369	08/10/2010	(2)
Attenuator	RADIALL	R41572000	0603033073	N.C.R.	-----
Power divider	Agilent	87302C	3239A00760	N.C.R.	-----
Test Site	ATL	TE02	TE02	N.C.R.	-----

Remark: ⁽¹⁾ Calibration period 1 year. ⁽²⁾ Calibration period 2 years.

NOTE: N.C.R. = No Calibration Request.

5.3. Setup

Below 2.8GHz

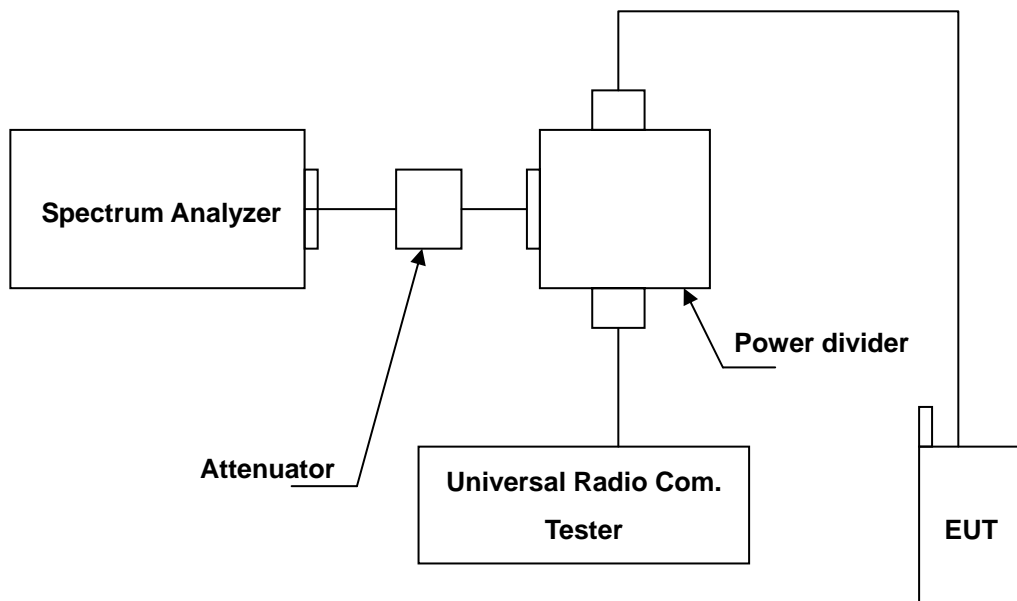

Above 2.8GHz

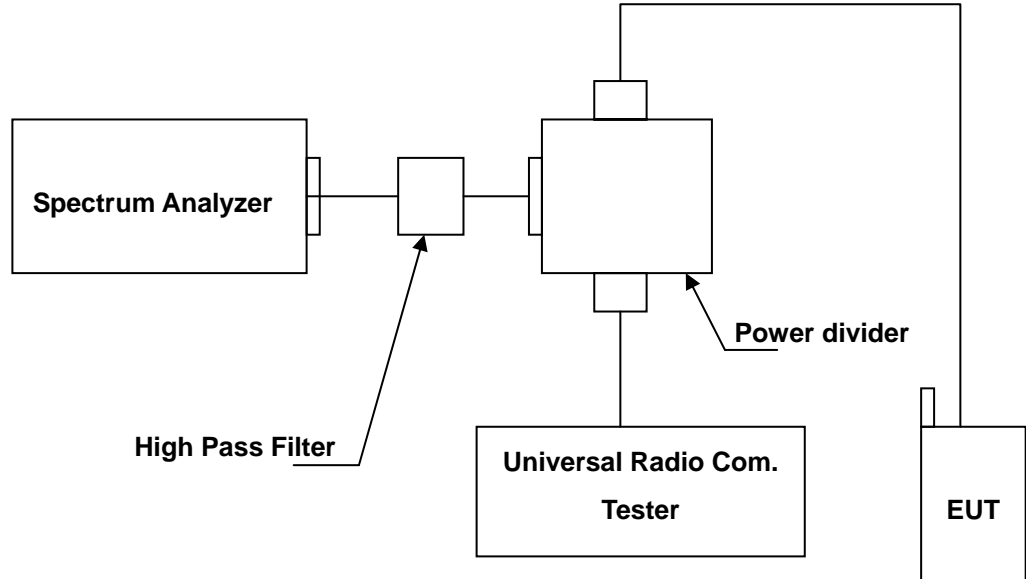

5.4. Test Procedure

1. The EUT was connected to Spectrum Analyzer and Base Station via power divider.
2. The middle channel for the highest RF power within the transmitting frequency was measured.
3. The conducted spurious emission for the whole frequency range was taken.
4. Test setting at WCDMA Band IV RB=1MHz, VB=3MHz.

5.5. Uncertainty

The measurement uncertainty is evaluated as ± 2.24 dB.

5.6. Test Result

Product	Smartphone		
Test Item	Conducted Emission		
Mode	Mode 3		
Date of Test	06/23/2011	Test Site	TE02
Note: The test results see next page.			

File: PG76210(CH25)

Data :#1

Date: 2011/6/23

Time: 下午 02:06:51

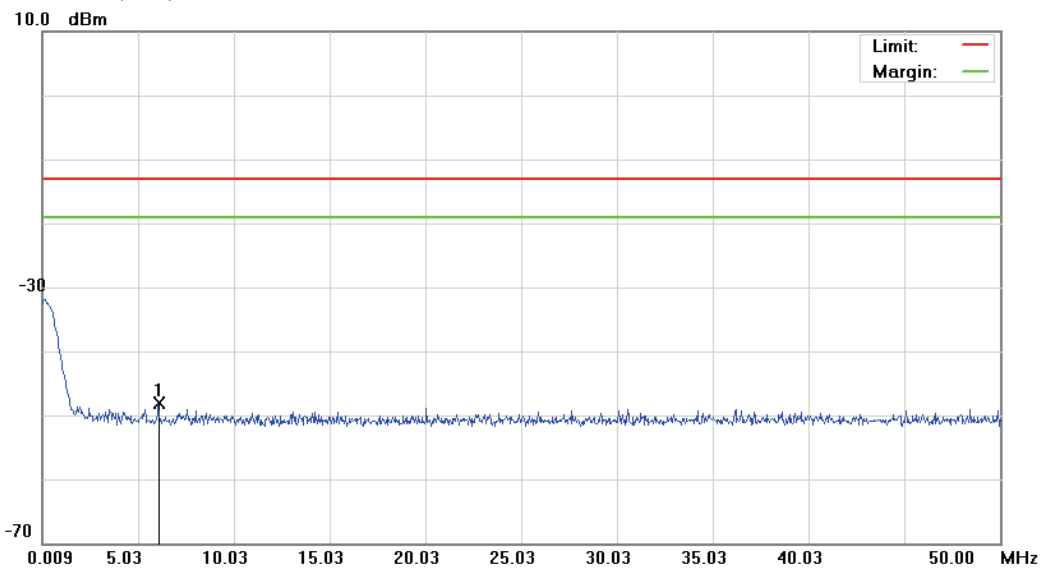

Site: : RF Conducted	Polarization: <i>Conducted po</i>	Temperature: 26 °C
Limit: FCC Part 24 conducted(9k-12.75G)	Power: AC 120V/60Hz	Humidity: 55 %
EUT: Smartphone	Distance:	RBW: 1000 KHz VBW: 1000 KHz
M/N: PG76210		
Mode: 3		
Note: CH25		

No.	Mk.	Freq.	Reading Level	Correct Factor	Measurement	Limit	Over	Antenna Height	Table Degree	Comment
		MHz	dBm	dB	dBm	dBm	dB	Detector	cm	degree
1	*	6.0580	-61.38	13.28	-48.10	-13.00	-35.10	peak		

*:Maximum data x:Over limit !:over margin

File: PG76210(CH25)

Data :#2

Date: 2011/6/23

Time: 下午 02:07:15

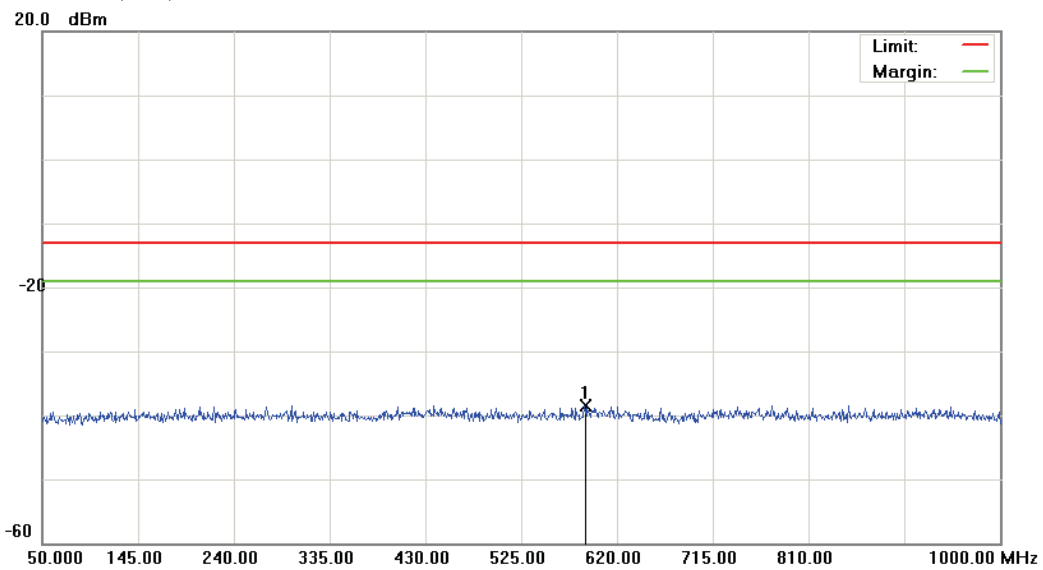

Site: RF Conducted	Polarization: <i>Conducted po</i>	Temperature: 26 °C
Limit: FCC Part 24 conducted(9k-12.75G)	Power: AC 120V/60Hz	Humidity: 55 %
EUT: Smartphone	Distance:	RBW: 1000 KHz VBW: 1000 KHz
M/N: PG76210		
Mode: 3		
Note: CH25		

No.	Mk.	Freq.	Reading Level	Correct Factor	Measurement	Limit	Over	Antenna Height	Table Degree	Detector	Comment
		MHz	dBm	dB	dBm	dBm	dB	cm	degree		
1	*	588.1750	-51.66	13.20	-38.46	-13.00	-25.46			peak	

*:Maximum data x:Over limit !:over margin

File: PG76210(CH25)

Data: #3

Date: 2011/6/23

Time: 下午 02:28:19

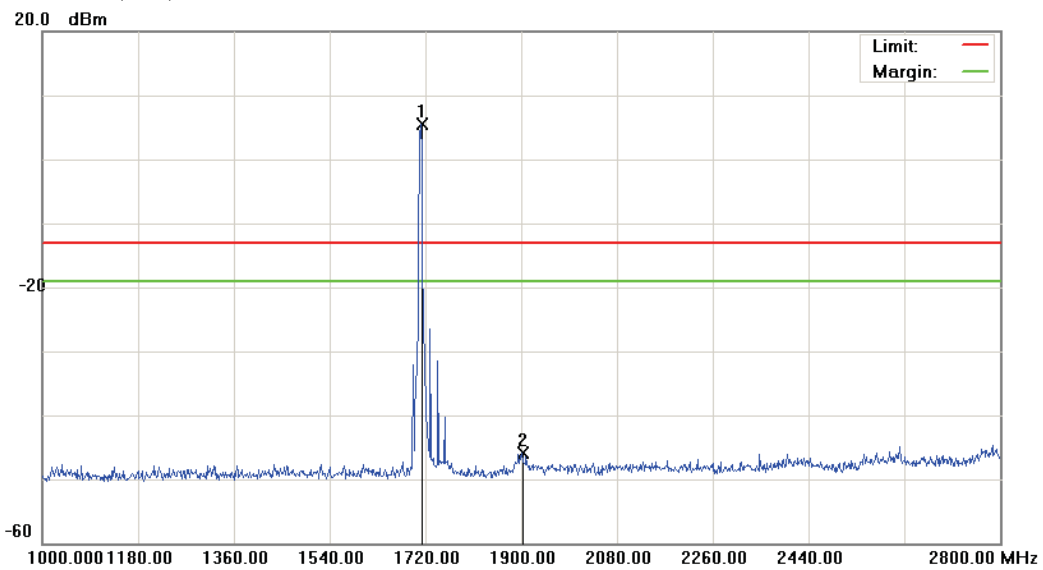

Site: : RF Conducted	Polarization: <i>Conducted po</i>	Temperature: 26 °C
Limit: FCC Part 24 conducted(9k-12.75G)	Power: AC 120V/60Hz	Humidity: 55 %
EUT: Smartphone	Distance:	RBW: 1000 KHz VBW: 1000 KHz
M/N: PG76210		
Mode: 3		
Note: CH25		

No.	Mk.	Freq. MHz	Reading Level dBm	Correct Factor dB	Measure- ment dBm	Limit dBm	Over dB	Detector	Antenna Height cm	Table Degree degree	Comment
1	*	1711.900	1.22	4.36	5.58	-13.00	18.58	peak			TX
2		1902.700	-52.24	6.38	-45.86	-13.00	-32.86	peak			

*:Maximum data x:Over limit !:over margin

File: PG76210(CH25)

Data :#4

Date: 2011/6/23

Time: 下午 03:02:11

20.0 dBm

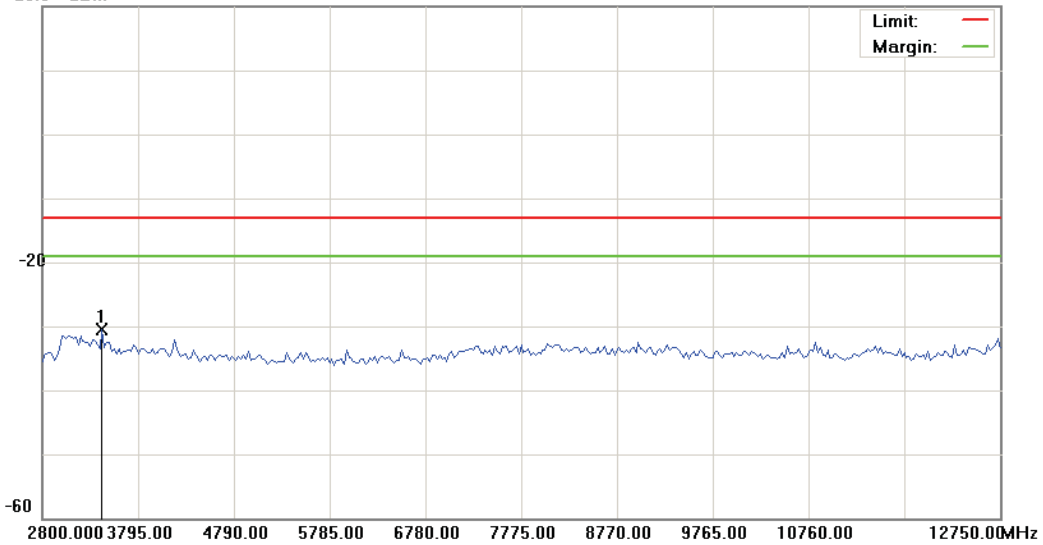

Site: : RF Conducted	Polarization: <i>Conducted po</i>	Temperature: 26 °C
Limit: FCC Part 24 conducted(9k-12.75G)	Power: AC 120V/60Hz	Humidity: 55 %
EUT: Smartphone	Distance:	RBW: 1000 KHz VBW: 1000 KHz
M/N: PG76210		
Mode: 3		
Note: CH25		

No.	Mk.	Freq.	Reading Level	Correct Factor	Measurement	Limit	Over	Antenna Height	Table Degree	Comment
		MHz	dBm	dB	dBm	dBm	dB	cm	degree	
1	*	3421.875	-35.49	5.06	-30.43	-13.00	-17.43	peak		

*:Maximum data x:Over limit !:over margin

File: PG76210(CH25)

Data :#5

Date: 2011/6/23

Time: 下午 03:02:36

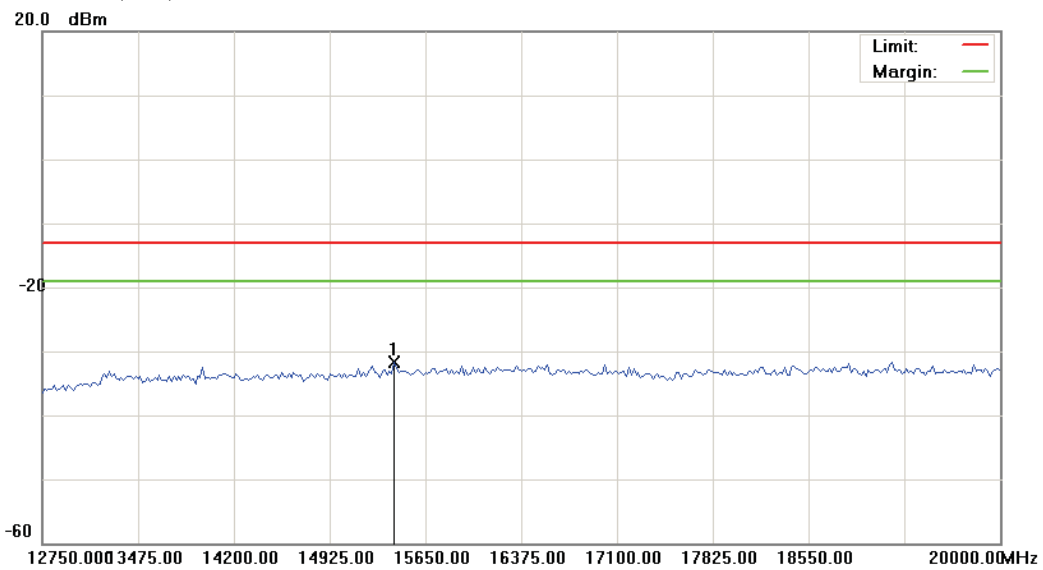

Site: : RF Conducted	Polarization: <i>Conducted po</i>	Temperature: 26 °C
Limit: FCC Part 24 conducted(9k-12.75G)	Power: AC 120V/60Hz	Humidity: 55 %
EUT: Smartphone	Distance:	RBW: 1000 KHz VBW: 1000 KHz
M/N: PG76210		
Mode: 3		
Note: CH25		

No.	Mk.	Freq.	Reading Level	Correct Factor	Measurement	Limit	Over	Antenna Height	Table Degree	Comment
		MHz	dBm	dB	dBm	dBm	dB	cm	degree	
1	*	15414.375	-37.73	6.13	-31.60	-13.00	-18.60	peak		

*:Maximum data x:Over limit !:over margin

File: PG76210(CH450) Data :#1 Date: 2011/6/23 Time: 下午 02:08:06

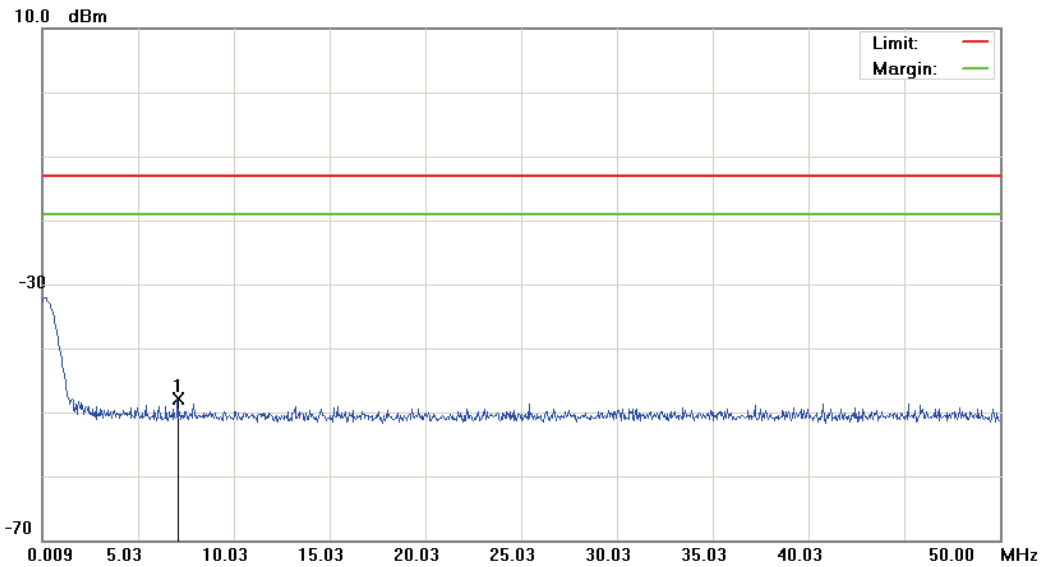

Site: RF Conducted	Polarization: <i>Conducted po</i>	Temperature: 26 °C
Limit: FCC Part 24 conducted(9k-12.75G)	Power: AC 120V/60Hz	Humidity: 55 %
EUT: Smartphone	Distance:	RBW: 1000 KHz VBW: 1000 KHz
M/N: PG76210		
Mode: 3		
Note: CH450		

No.	Mk.	Freq.	Reading Level	Correct Factor	Measurement	Limit	Over	Antenna Height	Table Degree	Comment
		MHz	dBm	dB	dBm	dBm	dB	cm	degree	
1	*	7.0827	-61.26	13.27	-47.99	-13.00	-34.99	peak		

*:Maximum data x:Over limit !:over margin

File:PG76210(CH450) Data :#2 Date:2011/6/23 Time: 下午 02:08:30

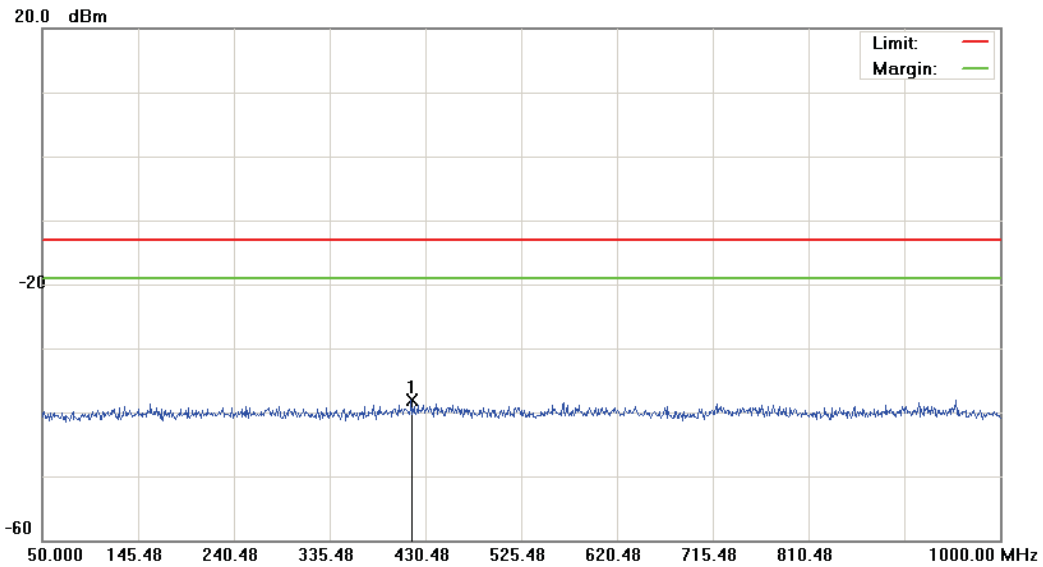

Site: : RF Conducted	Polarization: <i>Conducted po</i>	Temperature: 26 °C
Limit: FCC Part 24 conducted(9k-12.75G)	Power: AC 120V/60Hz	Humidity: 55 %
EUT: Smartphone	Distance:	RBW: 1000 KHz VBW: 1000 KHz
M/N: PG76210		
Mode: 3		
Note: CH450		

No.	Mk.	Freq.	Reading Level	Correct Factor	Measurement	Limit	Over	Antenna Height	Table Degree	Comment
		MHz	dBm	dB	dBm	dBm	dB	cm	degree	
1	*	416.2250	-51.24	13.22	-38.02	-13.00	-25.02	peak		

*:Maximum data x:Over limit !:over margin

File: PG76210(CH450) Data: #3 Date: 2011/6/23 Time: 下午 02:29:21

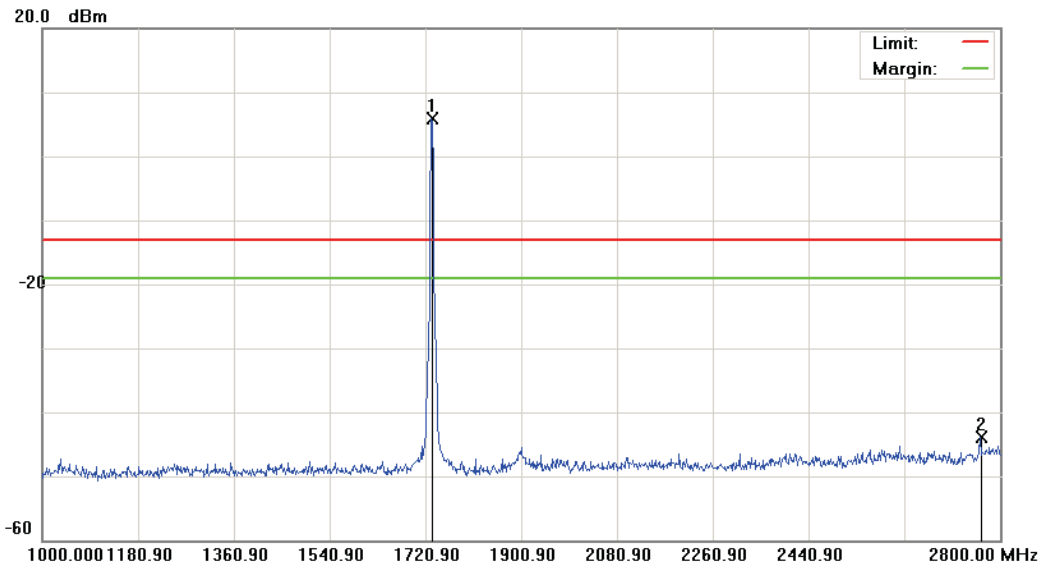

Site: : RF Conducted	Polarization: <i>Conducted po</i>	Temperature: 26 °C
Limit: FCC Part 24 conducted(9k-12.75G)	Power: AC 120V/60Hz	Humidity: 55 %
EUT: Smartphone	Distance:	RBW: 1000 KHz VBW: 1000 KHz
M/N: PG76210		
Mode: 3		
Note: CH450		

No.	Mk.	Freq. MHz	Reading Level dBm	Correct Factor dB	Measure- ment dBm	Limit dBm	Over dB	Detector	Antenna Height cm	Table Degree degree	Comment
1	*	1731.700	1.35	4.56	5.91	-13.00	18.91	peak			TX
2		2763.100	-49.59	5.64	-43.95	-13.00	-30.95	peak			

*:Maximum data x:Over limit !:over margin

File:PG76210(CH450) Data :#4 Date:2011/6/23 Time: 下午 03:03:26

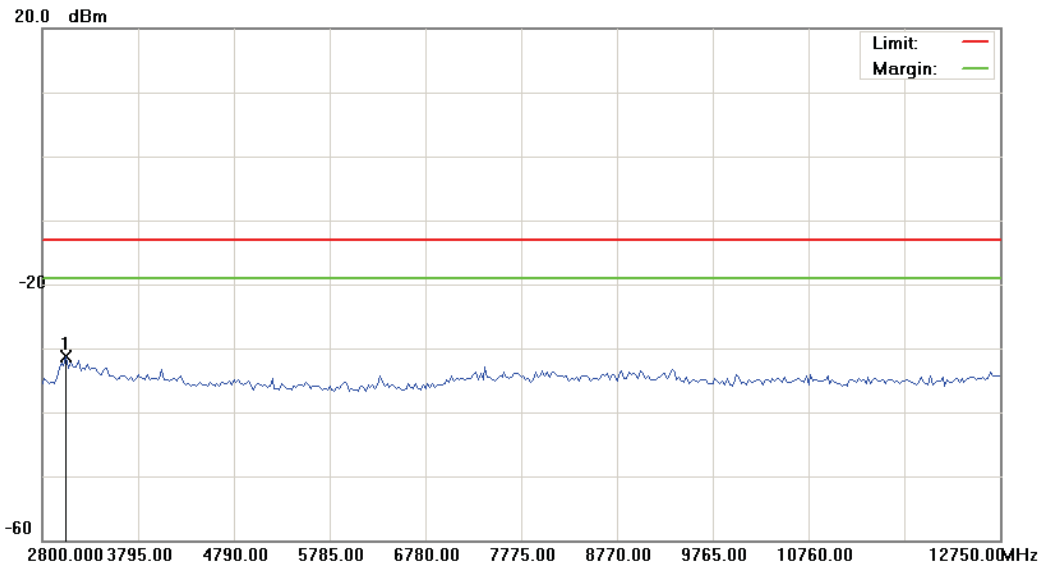

Site: : RF Conducted	Polarization: <i>Conducted po</i>	Temperature: 26 °C
Limit: FCC Part 24 conducted(9k-12.75G)	Power: AC 120V/60Hz	Humidity: 55 %
EUT: Smartphone	Distance:	RBW: 1000 KHz VBW: 1000 KHz
M/N: PG76210		
Mode: 3		
Note: CH450		

No.	Mk.	Freq.	Reading Level	Correct Factor	Measurement	Limit	Over	Antenna Height	Table Degree	Comment
		MHz	dBm	dB	dBm	dBm	dB	Detector	cm	degree
1	*	3048.750	-36.86	5.47	-31.39	-13.00	-18.39	peak		

*:Maximum data x:Over limit !:over margin

File: PG76210(CH450) Data :#5 Date: 2011/6/23 Time: 下午 03:03:51

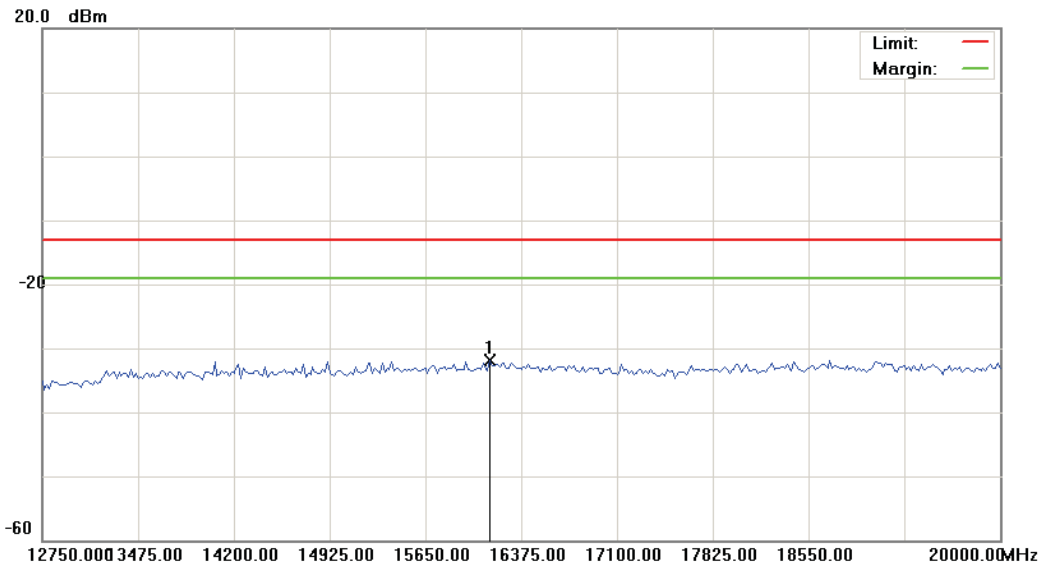

Site: : RF Conducted	Polarization: <i>Conducted po</i>	Temperature: 26 °C
Limit: FCC Part 24 conducted(9k-12.75G)	Power: AC 120V/60Hz	Humidity: 55 %
EUT: Smartphone	Distance:	RBW: 1000 KHz VBW: 1000 KHz
M/N: PG76210		
Mode: 3		
Note: CH450		

No.	Mk.	Freq.	Reading Level	Correct Factor	Measurement	Limit	Over	Antenna Height	Table Degree	Detector	Comment
		MHz	dBm	dB	dBm	dBm	dB	cm	degree		
1	*	16139.375	-38.16	6.34	-31.82	-13.00	-18.82			peak	

*:Maximum data x:Over limit !:over margin

File: PG76210(CH875)

Data :#1

Date: 2011/6/23

Time: 下午 02:10:02

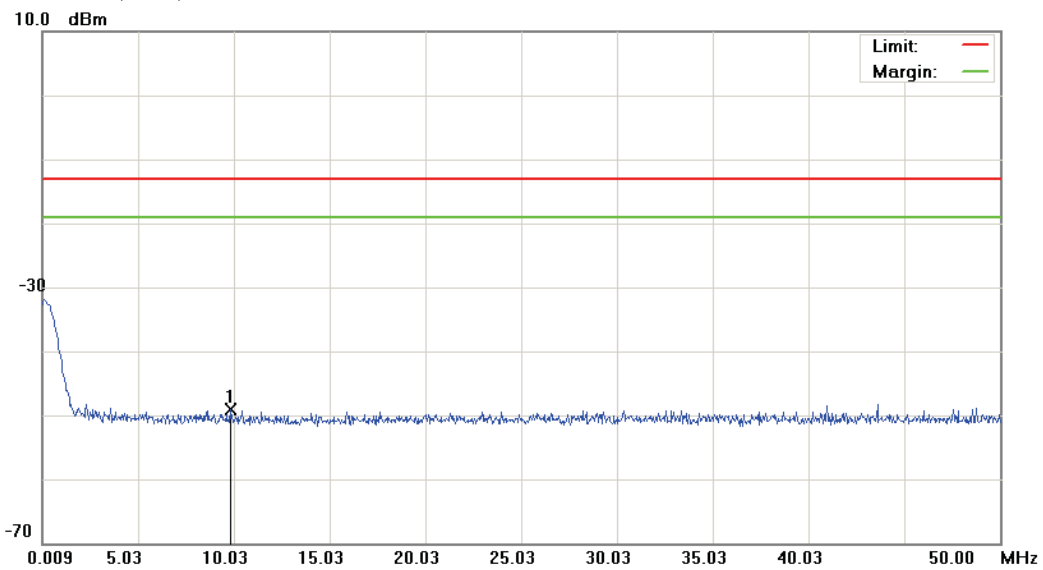

Site: RF Conducted	Polarization: <i>Conducted po</i>	Temperature: 26 °C
Limit: FCC Part 24 conducted(9k-12.75G)	Power: AC 120V/60Hz	Humidity: 55 %
EUT: Smartphone	Distance:	RBW: 1000 KHz VBW: 1000 KHz
M/N: PG76210		
Mode: 3		
Note: CH875		

No.	Mk.	Freq.	Reading Level	Correct Factor	Measurement	Limit	Over	Antenna Height	Table Degree	Comment
		MHz	dBm	dB	dBm	dBm	dB	Detector	cm	degree
1	*	9.8322	-62.38	13.29	-49.09	-13.00	-36.09	peak		

*:Maximum data x:Over limit !:over margin

File:PG76210(CH875) Data :#2 Date:2011/6/23 Time: 下午 02:10:26

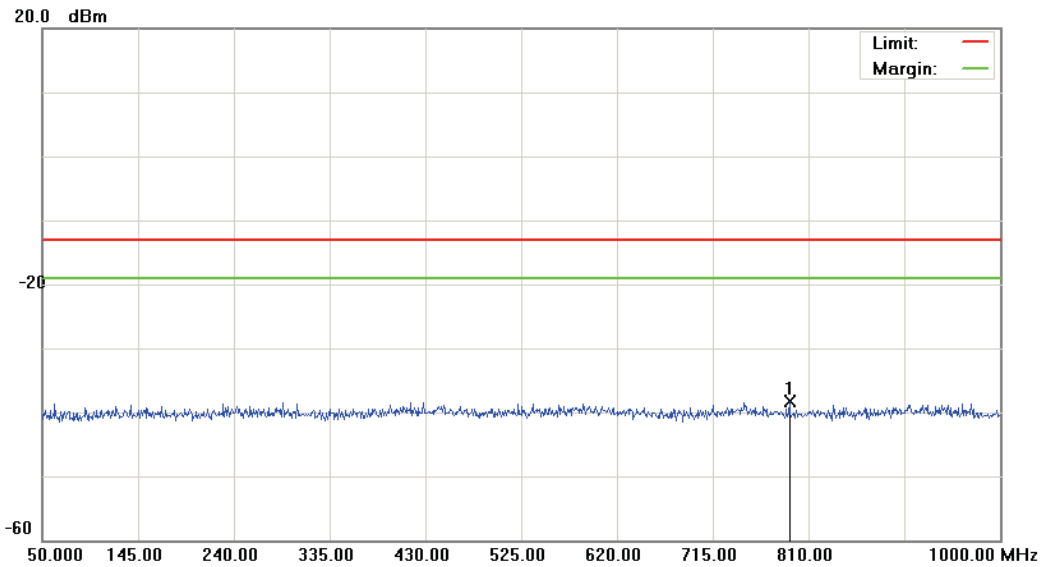

Site: : RF Conducted	Polarization: <i>Conducted po</i>	Temperature: 26 °C
Limit: FCC Part 24 conducted(9k-12.75G)	Power: AC 120V/60Hz	Humidity: 55 %
EUT: Smartphone	Distance:	RBW: 1000 KHz VBW: 1000 KHz
M/N: PG76210		
Mode: 3		
Note: CH875		

No.	Mk.	Freq.	Reading Level	Correct Factor	Measurement	Limit	Over	Antenna Height	Table Degree	
		MHz	dBm	dB	dBm	dBm	dB	Detector	cm	degree
1	*	791.4750	-51.35	13.15	-38.20	-13.00	-25.20	peak		Comment

*:Maximum data x:Over limit !:over margin

File: PG76210(CH875)

Data :#3

Date: 2011/6/23

Time: 下午 02:30:36

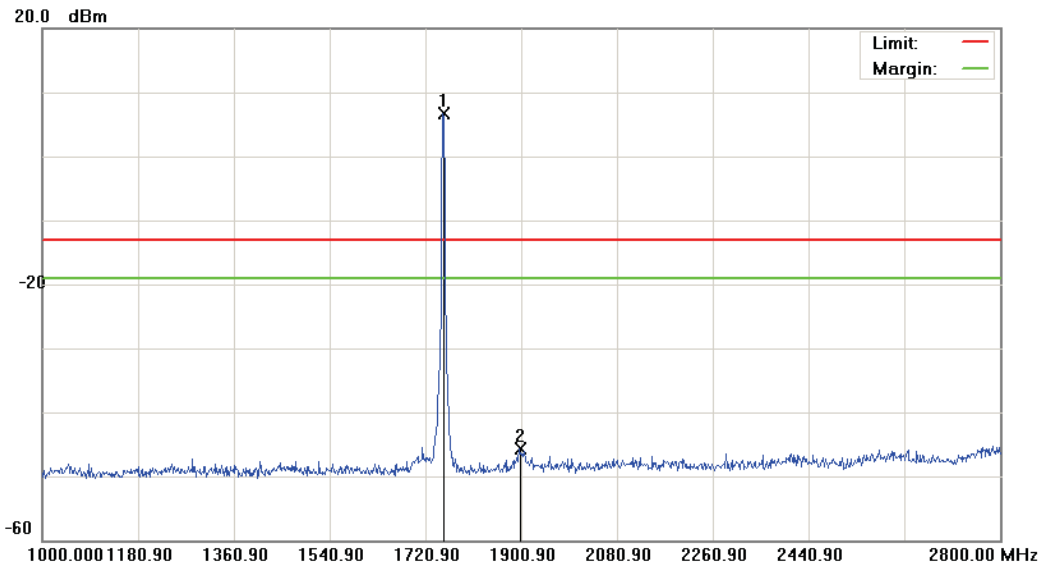

Site: : RF Conducted	Polarization: <i>Conducted po</i>	Temperature: 26 °C
Limit: FCC Part 24 conducted(9k-12.75G)	Power: AC 120V/60Hz	Humidity: 55 %
EUT: Smartphone	Distance:	RBW: 1000 KHz VBW: 1000 KHz
M/N: PG76210		
Mode: 3		
Note: CH875		

No.	Mk.	Freq. MHz	Reading Level dBm	Correct Factor dB	Measure- ment dBm	Limit dBm	Over dB	Detector	Antenna Height cm	Table Degree degree	Comment
1	*	1753.300	2.11	4.63	6.74	-13.00	19.74	peak			TX
2		1897.300	-52.06	6.36	-45.70	-13.00	-32.70	peak			

*:Maximum data x:Over limit !:over margin

File: PG76210(CH875) Data :#4 Date: 2011/6/23 Time: 下午 03:04:58

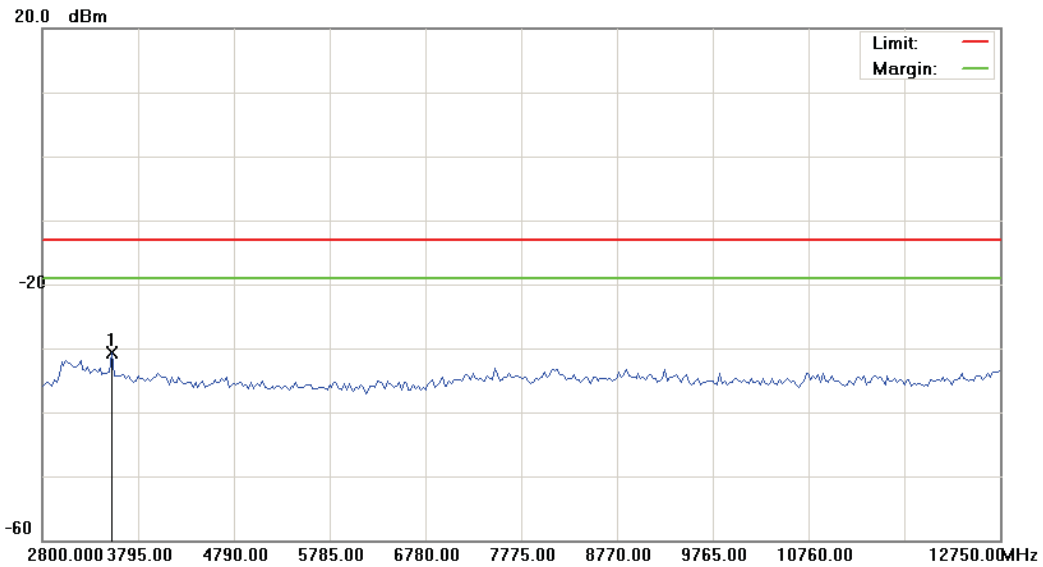

Site: RF Conducted	Polarization: <i>Conducted po</i>	Temperature: 26 °C
Limit: FCC Part 24 conducted(9k-12.75G)	Power: AC 120V/60Hz	Humidity: 55 %
EUT: Smartphone	Distance:	RBW: 1000 KHz VBW: 1000 KHz
M/N: PG76210		
Mode: 3		
Note: CH875		

No.	Mk.	Freq.	Reading Level	Correct Factor	Measurement	Limit	Over	Antenna Height	Table Degree	Comment
		MHz	dBm	dB	dBm	dBm	dB	Detector	cm	degree
1	*	3521.375	-35.70	4.95	-30.75	-13.00	-17.75	peak		

*:Maximum data x:Over limit !:over margin

File:PG76210(CH875) Data :#5 Date:2011/6/23 Time: 下午 03:05:23

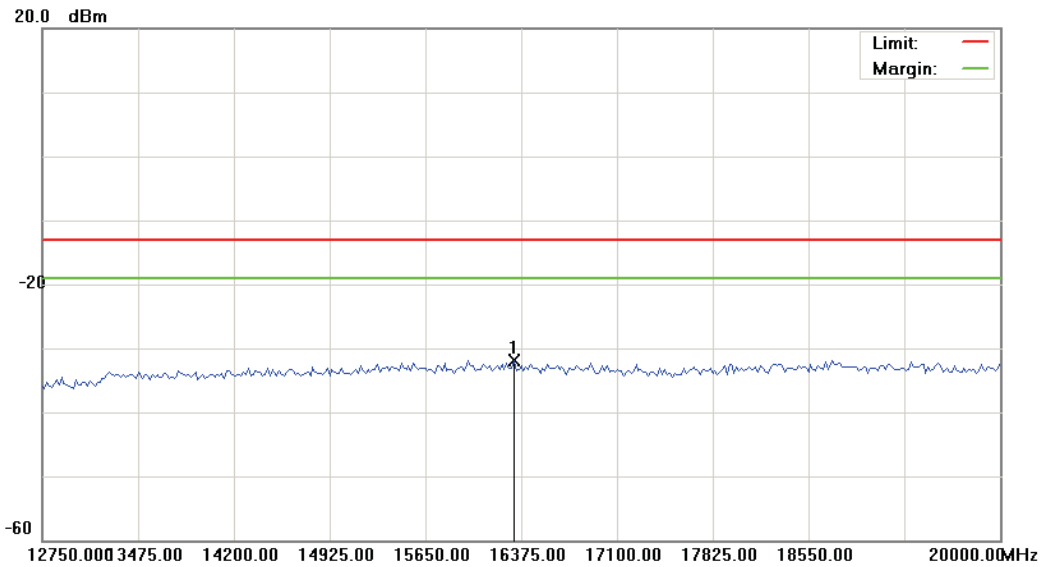

Site: : RF Conducted	Polarization: <i>Conducted po</i>	Temperature: 26 °C
Limit: FCC Part 24 conducted(9k-12.75G)	Power: AC 120V/60Hz	Humidity: 55 %
EUT: Smartphone	Distance:	RBW: 1000 KHz VBW: 1000 KHz
M/N: PG76210		
Mode: 3		
Note: CH875		

No.	Mk.	Freq.	Reading Level	Correct Factor	Measurement	Limit	Over	Antenna Height	Table Degree	Comment
		MHz	dBm	dB	dBm	dBm	dB	cm	degree	
1	*	16320.625	-38.32	6.39	-31.93	-13.00	-18.93	peak		

*:Maximum data x:Over limit !:over margin

6 Field Strength of Spurious Radiation Test

6.1. Limit

The power of any emission outside of the authorized operating frequency ranges must be attenuated below the transmitting power (P) by a factor of at least $43 + 10\log(P)$ dB.

It is measured by means of a calibrated spectrum analyzer and scanned from 30 MHz up to a frequency including its 10th harmonic.

6.2. Test Instruments

3 Meter Chamber					
Equipment	Manufacturer	Model No.	Serial No.	Cal. Date	Remark
RF Pre-selector	Agilent	N9039A	MY46520256	01/18/2011	(2)
Spectrum Analyzer	Agilent	E4446A	MY46180578	01/18/2011	(1)
Pre Amplifier	Agilent	8449B	3008A02237	02/23/2011	(1)
Pre Amplifier	Agilent	8447D	2944A10961	02/23/2011	(1)
Broadband Antenna (30MHz~1GHz)	SCHWARZBECK MESS-ELEKTRONIK	VULB9163	9163-270	08/02/2010	(1)
Horn Antenna (1~18GHz)	SCHWARZBECK MESS-ELEKTRONIK	BBHA9120D	9120D-550	06/29/2010	(1)
Horn Antenna (18~40GHz)	SCHWARZBECK MESS-ELEKTRONIK	BBHA9170	9170-320	06/29/2010	(1)
Test Site	ATL	TE01	888001	07/30/2010	(1)

Remark: ⁽¹⁾ Calibration period 1 year. ⁽²⁾ Calibration period 2 years.

NOTE: N.C.R. = No Calibration Request.

6.3. Setup

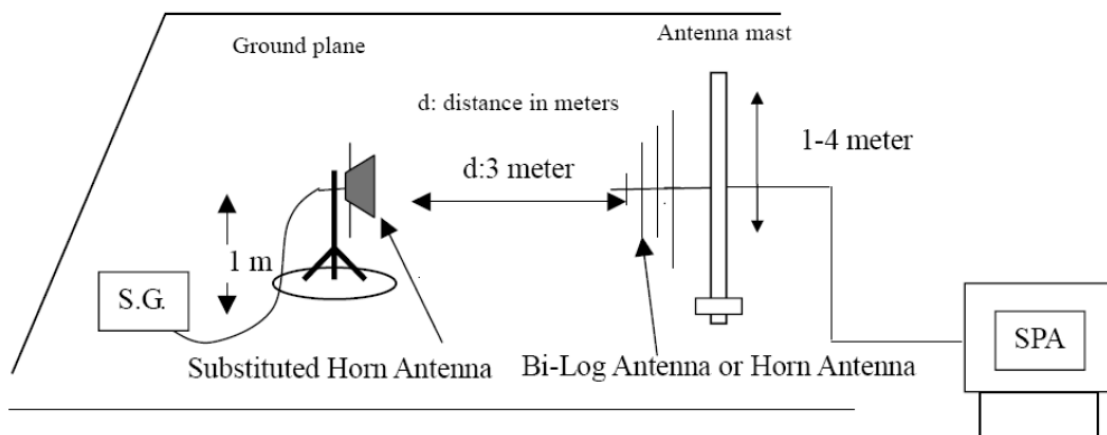

6.4. Test Procedure

The measurement is made according to ANSI/TIA-603-C-2004 as follows:

The equipment under test is placed inside the semi-anechoic chamber on a wooden table at the turntable center. For each spurious frequency, the antenna mast is raised and lowered from 1 to 4 meters and the turntable is rotated 360 degrees to obtain a maximum reading on the spectrum analyzer. This is repeated for both horizontal and vertical polarizations of the receive antenna.

The equipment under test is then replaced with a substitution antenna fed by a signal generator. With the signal generator tuned to a particular spurious frequency, the antenna mast is raised and lowered from 1 to 4 meters to obtain a maximum reading at the spectrum analyzer. The output of the signal generator is then adjusted until a reading identical to that obtained with the actual transmitter is achieved.

The power in dBm of each spurious emission is calculated by correcting the signal generator level for cable loss and gain of the substitution antenna referenced to a dipole. A fully charged battery was used for the supply voltage.

The settings of the receiver were as follows:

Units	dBm
Resolution Bandwidth	1 MHz
Video Bandwidth	Auto
Sweep Time	Auto

6.5. Uncertainty

The measurement uncertainty is defined as for Field Strength of Spurious Radiation measurement is ± 3.072 dB.

6.6. Test Result

Standard:	FCC Part 27	Test Distance:	3m
Test item:	Radiated Emission	Power:	AC 120V/60Hz
Model:	PG76210	Temp.(°C)/Hum.(%RH):	26(°C)/60%RH
Mode:	Mode 3	Date:	06/24/2011
Frequency:	1711.25 MHz	Test By:	Gary Wu

No.	Frequency (MHz)	Reading (dBm)	Correct Factor(dB)	Result (dBm)	Limit (dBm)	Margin (dB)	Remark	Ant.Polar. H / V
1	93.5000	-70.30	-0.61	-70.91	-13.00	-57.91	peak	H
2	247.0000	-66.72	-3.57	-70.29	-13.00	-57.29	peak	H
3	314.5000	-72.83	-1.31	-74.14	-13.00	-61.14	peak	H
4	546.5000	-81.29	8.11	-73.18	-13.00	-60.18	peak	H
5	634.0000	-77.80	7.08	-70.72	-13.00	-57.72	peak	H
6	773.5000	-81.98	9.83	-72.15	-13.00	-59.15	peak	H
7	3604.000	-67.96	15.53	-52.43	-13.00	-39.43	peak	H
8	6616.000	-72.26	26.36	-45.90	-13.00	-32.90	peak	H
9	7360.000	-71.41	28.70	-42.71	-13.00	-29.71	peak	H
1	123.0000	-70.82	7.42	-63.40	-13.00	-50.40	peak	V
2	165.0000	-73.19	7.96	-65.23	-13.00	-52.23	peak	V
3	240.0000	-68.24	0.38	-67.86	-13.00	-54.86	peak	V
4	303.5000	-75.37	2.42	-72.95	-13.00	-59.95	peak	V
5	621.5000	-79.23	8.88	-70.35	-13.00	-57.35	peak	V
6	869.0000	-80.64	11.28	-69.36	-13.00	-56.36	peak	V
7	5068.000	-71.40	23.29	-48.11	-13.00	-35.11	peak	V
8	7324.000	-70.09	26.11	-43.98	-13.00	-30.98	peak	V
9	9304.000	-70.86	26.82	-44.04	-13.00	-31.04	peak	V

Standard:	FCC Part 27	Test Distance:	3m
Test item:	Radiated Emission	Power:	AC 120V/60Hz
Model:	PG76210	Temp.(°C)/Hum.(%RH):	26(°C)/60%RH
Mode:	Mode 3	Date:	06/24/2011
Frequency:	1732.50 MHz	Test By:	Gary Wu

No.	Frequency (MHz)	Reading (dBm)	Correct Factor(dB)	Result (dBm)	Limit (dBm)	Margin (dB)	Remark	Ant.Polar. H / V
1	89.5000	-69.26	-0.14	-69.40	-13.00	-56.40	peak	H
2	248.5000	-66.78	-3.90	-70.68	-13.00	-57.68	peak	H
3	315.5000	-73.23	-1.24	-74.47	-13.00	-61.47	peak	H
4	464.5000	-81.03	4.87	-76.16	-13.00	-63.16	peak	H
5	553.0000	-80.32	7.97	-72.35	-13.00	-59.35	peak	H
6	680.0000	-78.41	7.02	-71.39	-13.00	-58.39	peak	H
7	3604.000	-69.93	15.53	-54.40	-13.00	-41.40	peak	H
8	7348.000	-72.82	28.67	-44.15	-13.00	-31.15	peak	H
9	9148.000	-72.83	27.48	-45.35	-13.00	-32.35	peak	H
1	136.5000	-73.98	10.84	-63.14	-13.00	-50.14	peak	V
2	164.5000	-73.30	8.44	-64.86	-13.00	-51.86	peak	V
3	237.0000	-67.84	0.93	-66.91	-13.00	-53.91	peak	V
4	305.5000	-76.10	2.25	-73.85	-13.00	-60.85	peak	V
5	490.5000	-79.18	2.58	-76.60	-13.00	-63.60	peak	V
6	612.5000	-77.33	8.36	-68.97	-13.00	-55.97	peak	V
7	3460.000	-68.20	19.06	-49.14	-13.00	-36.14	peak	V
8	5392.000	-72.65	23.43	-49.22	-13.00	-36.22	peak	V
9	8308.000	-71.60	26.20	-45.40	-13.00	-32.40	peak	V

Standard:	FCC Part 27	Test Distance:	3m
Test item:	Radiated Emission	Power:	AC 120V/60Hz
Model:	PG76210	Temp.(°C)/Hum.(%RH):	26(°C)/60%RH
Mode:	Mode 3	Date:	06/24/2011
Frequency:	1753.75 MHz	Test By:	Gary Wu

No.	Frequency (MHz)	Reading (dBm)	Correct Factor(dB)	Result (dBm)	Limit (dBm)	Margin (dB)	Remark	Ant.Polar. H / V
1	90.5000	-66.98	-0.07	-67.05	-13.00	-54.05	peak	H
2	247.5000	-66.82	-3.67	-70.49	-13.00	-57.49	peak	H
3	320.0000	-72.07	-0.92	-72.99	-13.00	-59.99	peak	H
4	582.5000	-77.93	7.64	-70.29	-13.00	-57.29	peak	H
5	624.5000	-76.91	7.51	-69.40	-13.00	-56.40	peak	H
6	847.0000	-81.60	12.41	-69.19	-13.00	-56.19	peak	H
7	3616.000	-69.45	15.56	-53.89	-13.00	-40.89	peak	H
8	7156.000	-71.62	28.12	-43.50	-13.00	-30.50	peak	H
9	8512.000	-72.37	28.62	-43.75	-13.00	-30.75	peak	H
1	130.5000	-78.54	14.09	-64.45	-13.00	-51.45	peak	V
2	164.5000	-72.30	8.44	-63.86	-13.00	-50.86	peak	V
3	241.0000	-67.32	0.24	-67.08	-13.00	-54.08	peak	V
4	301.5000	-76.51	2.59	-73.92	-13.00	-60.92	peak	V
5	489.0000	-79.24	2.54	-76.70	-13.00	-63.70	peak	V
6	692.0000	-81.30	9.94	-71.36	-13.00	-58.36	peak	V
7	5512.000	-71.95	23.48	-48.47	-13.00	-35.47	peak	V
8	7792.000	-72.09	26.50	-45.59	-13.00	-32.59	peak	V
9	11512.000	-73.83	38.10	-35.73	-13.00	-22.73	peak	V

7 Frequency Stability (Temperature Variation) Test

7.1. Limit

The frequency stability shall be measured by variation of ambient temperature and variation of primary supply voltage to ensure that the fundamental emission stays within the authorized frequency block. The frequency stability of the transmitter shall be maintained within $\pm 0.00025\%$ ($\pm 2.5\text{ppm}$) of the center frequency.

7.2. Test Instruments

Describe	Manufacturer	Model No.	Serial No.	Cal. Date	Remark
Universal Radio Communication Tester	ROHDE & SCHWARZ	CMU200	109369	08/10/2010	(2)
Temperature & Humidity Chamber	TAICHY	MHU-225LA	980729	08/26/2010	(2)
Test Site	ATL	TE02	TE02	N.C.R.	-----

Remark: ⁽¹⁾ Calibration period 1 year. ⁽²⁾ Calibration period 2 years.

NOTE: N.C.R. = No Calibration Request.

7.3. Setup

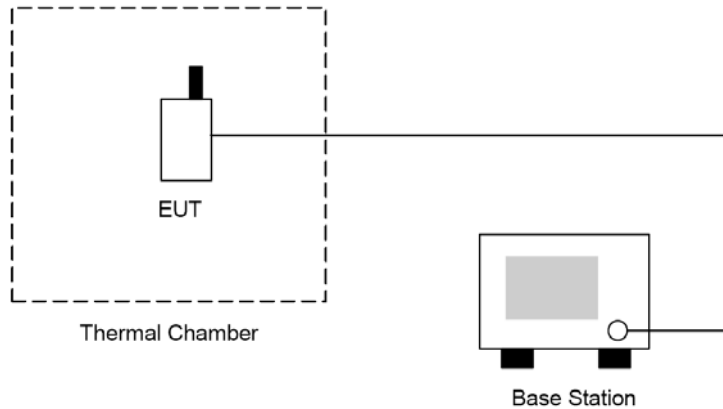

7.4. Test Procedure

The measurement is made according to FCC rules part 27:

1. The EUT and test equipment were set up as shown on the following section.
2. With all power removed, the temperature was decreased to -30°C and permitted to stabilize for three hours. Power was applied and the maximum change in frequency was noted within one minute.
3. With power OFF, the temperature was raised in 10°C steps. The sample was permitted to stabilize at each step for at least one-half hour. Power was applied and the maximum frequency change was noted within one minute.
4. The temperature tests were performed for the worst case.
5. Test data was recorded.

7.5. Uncertainty

The measurement uncertainty is defined as for Frequency Stability (Temperature Variation) measurement is $\pm 10\text{Hz}$.

7.6. Test Result

Product	Smartphone			
Test Item	Frequency Stability (Temperature Variation)			
Test Mode	Mode 3			
Date of Test	06/23/2011		Test Site	TE02
Temperature (°C)	Deviation (Hz)	Deviation (ppm)	Limit (ppm)	Result
-30	44	0.025	± 2.5	Pass
-20	-22	-0.013	± 2.5	Pass
-10	41	0.024	± 2.5	Pass
0	-33	-0.019	± 2.5	Pass
10	-39	-0.023	± 2.5	Pass
20	-45	-0.026	± 2.5	Pass
30	38	0.022	± 2.5	Pass
40	-36	-0.021	± 2.5	Pass
50	-35	-0.020	± 2.5	Pass

8 Frequency Stability (Voltage Variation) Test

8.1. Limit

The frequency stability shall be measured by variation of ambient temperature and variation of primary supply voltage to ensure that the fundamental emission stays within the authorized frequency block.

The frequency stability of the transmitter shall be maintained within $\pm 0.00025\%$ ($\pm 2.5\text{ppm}$) of the center frequency.

8.2. Test Instruments

Describe	Manufacturer	Model No.	Serial No.	Cal. Date	Remark
Universal Radio Communication Tester	ROHDE & SCHWARZ	CMU200	109369	08/10/2010	(2)
Temperature & Humidity Chamber	TAICHY	MHU-225LA	980729	08/26/2010	(2)
Test Site	ATL	TE02	TE02	N.C.R.	-----

Remark: ⁽¹⁾ Calibration period 1 year. ⁽²⁾ Calibration period 2 years.

NOTE: N.C.R. = No Calibration Request.

8.3. Setup

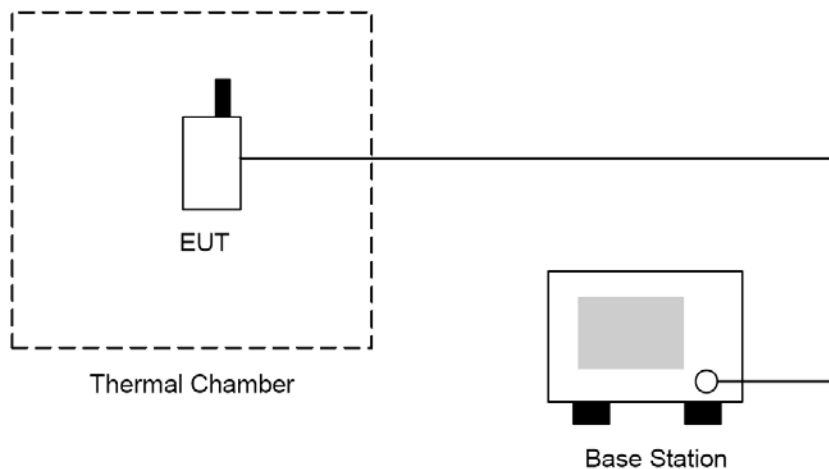

8.4. Test Procedure

1. The EUT was placed in a temperature chamber at $25 \pm 5^\circ\text{C}$ and connected as the following section.
2. The power supply voltage to the EUT was varied from BEP to 115% of the nominal value measured at the input to the EUT.
3. The variation in frequency was measured for the worst case.

8.5. Uncertainty

The measurement uncertainty is defined as for Frequency Stability (Voltage Variation) measurement is $\pm 10\text{Hz}$.

8.6. Test Result

Product	Smartphone				
Test Item	Frequency Stability (Voltage Variation)				
Test Mode	Mode 3				
Date of Test	06/23/2011		Test Site	TE02	
Level	Voltage [V]	Deviation [Hz]	Deviation [ppm]	Limit [ppm]	Result
Battery full point	4.07	33	0.019	±2.5	Pass
Normal	3.70	38	0.022	±2.5	Pass
Battery cut-off point	3.33	34	0.020	±2.5	Pass

9 AC Power Conducted Emissions Test

9.1. Limit

Frequency range (MHz)	Limits (dBuV)	
	Quasi-peak	Average
0.15 to 0.50	66 to 56	56 to 46
0.50 to 5.0	56	46
5.0 to 30	60	50

9.2. Test Instruments

Describe	Manufacturer	Model No.	Serial No.	Cal. Date	Remark
Test Receiver	R&S	ESCI	100367	07/01/2009	(1)
LISN	R&S	ENV216	101040	03/04/2011	(1)
LISN	R&S	ENV216	101041	03/04/2011	(1)
Test Site	ATL	TE02	TE02	N.C.R.	-----

Remark: ⁽¹⁾ Calibration period 1 year. ⁽²⁾ Calibration period 2 years.

NOTE: N.C.R. = No Calibration Request.

9.3. Setup

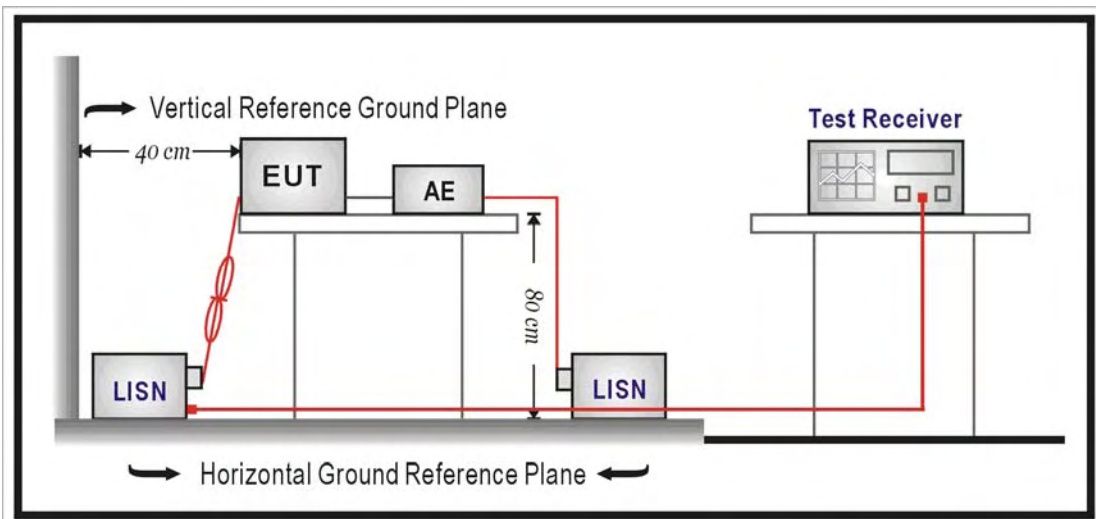

9.4. Test Procedure

The measurement is made according to FCC rules 15.207:

The power line conducted emission measurements were performed in a shielded enclosure. The EUT was assembled on a wooden table which is 80 centimeters high, was placed 40 centimeters from the back wall and at least 1 meter from the sidewall.

Power was fed to the EUT from the public utility power grid through a line filter and EMCO Model 3162/2 SH Line Impedance Stabilization Networks (LISN). The LISN housing, measuring instrumentation case, ground plane, etc., were electrically bonded together at the same RF potential. The Spectrum analyzer was connected to the AC line through an isolation transformer. The 50-ohm output of the LISN was connected to the spectrum analyzer directly. Conducted emission levels were in the CISPR quasi-peak detection mode. The analyzer's 6 dB bandwidth was set to 9 KHz. No post-detector video filter was used.

The spectrum was scanned from 150 KHz to 30 MHz. The physical arrangement of the test system and associated cabling was varied (within the scope of arrangements likely to be encountered in actual use) to determine the effect on the unit's emanations in amplitude and frequency. All spurious emission frequencies were observed. The highest emission amplitudes relative to the appropriate limit were measured and have been recorded in section 10.6.

9.5. Uncertainty

The measurement uncertainty is defined as for AC power conducted emission measurement is ± 2.24 dB.

9.6. Test Result

Standard:	FCC Part 27	Line:	L1
Test item:	Conducted Emission	Power:	AC 120V/60Hz
Model:	PG76210	Temp.(°C)/Hum.(%RH):	26(°C)/60%RH
Mode:	Mode 3	Date:	06/29/2011
		Test By:	Gary Wu
Description:			

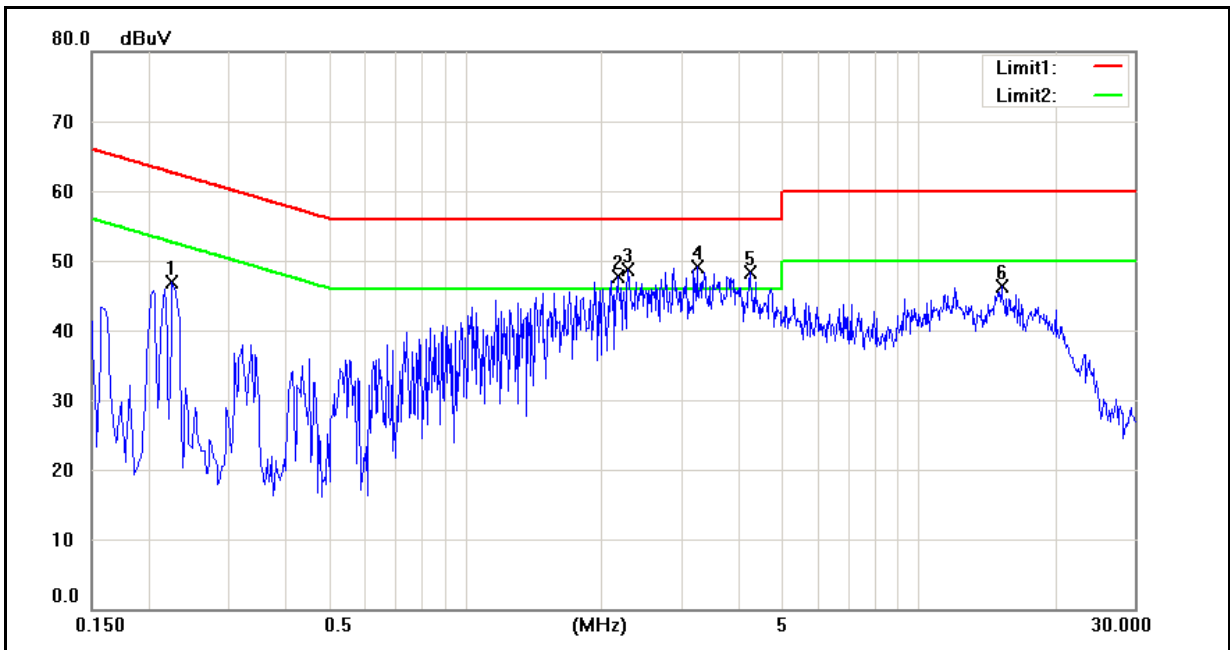

No.	Frequency (MHz)	QP reading (dBuV)	AVG reading (dBuV)	Correction factor (dB)	QP result (dBuV)	AVG result (dBuV)	QP limit (dBuV)	AVG limit (dBuV)	QP margin (dB)	AVG margin (dB)	Remark
1	0.2260	18.67	6.28	10.04	28.71	16.32	62.60	52.60	-33.89	-36.28	Pass
2	2.1700	30.47	18.83	9.70	40.17	28.53	56.00	46.00	-15.83	-17.47	Pass
3	2.2860	23.01	11.64	9.71	32.72	21.35	56.00	46.00	-23.28	-24.65	Pass
4	3.2540	22.85	13.09	9.80	32.65	22.89	56.00	46.00	-23.35	-23.11	Pass
5	4.2500	27.74	16.50	9.81	37.55	26.31	56.00	46.00	-18.45	-19.69	Pass
6	15.2300	26.65	16.87	10.19	36.84	27.06	60.00	50.00	-23.16	-22.94	Pass

Standard:	FCC Part 27	Line:	N
Test item:	Conducted Emission	Power:	AC 120V/60Hz
Model:	PG76210	Temp.(°C)/Hum.(%RH):	26(°C)/60%RH
Mode:	Mode 3	Date:	06/29/2011
		Test By:	Gary Wu
Description:			

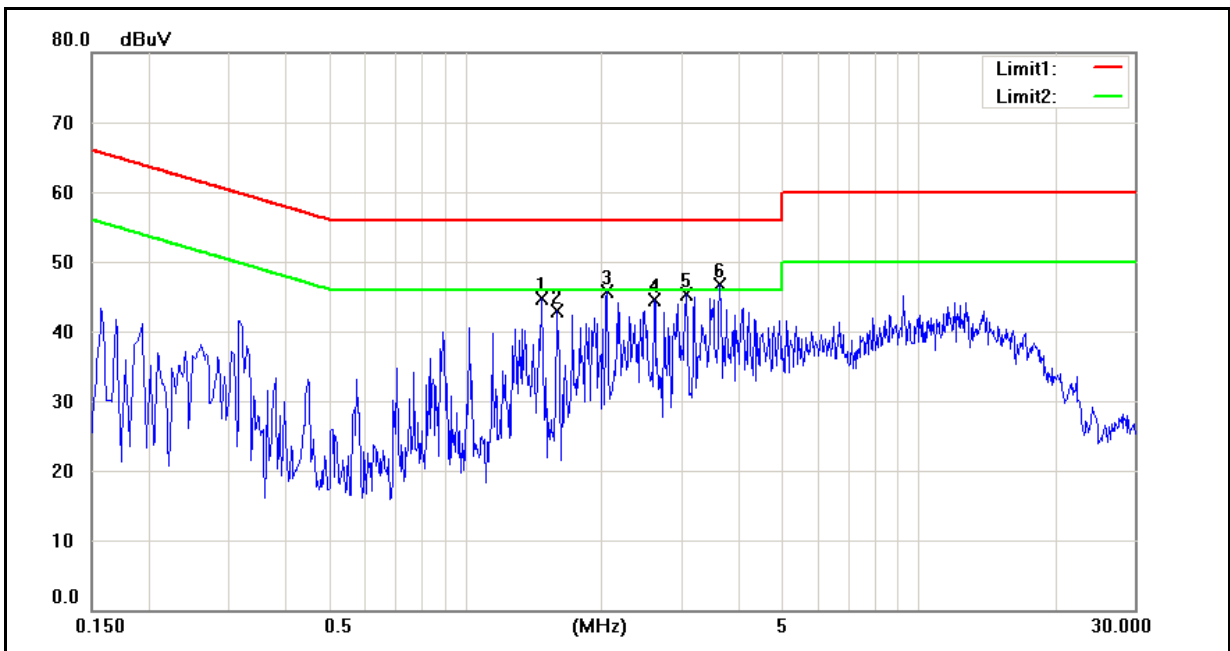

No.	Frequency (MHz)	QP reading (dBuV)	AVG reading (dBuV)	Correction factor (dB)	QP result (dBuV)	AVG result (dBuV)	QP limit (dBuV)	AVG limit (dBuV)	QP margin (dB)	AVG margin (dB)	Remark
1	1.4780	30.65	17.58	9.75	40.40	27.33	56.00	46.00	-15.60	-18.67	Pass
2	1.5980	29.47	18.22	9.75	39.22	27.97	56.00	46.00	-16.78	-18.03	Pass
3	2.0580	31.12	17.39	9.75	40.87	27.14	56.00	46.00	-15.13	-18.86	Pass
4	2.6220	29.08	18.52	9.82	38.90	28.34	56.00	46.00	-17.10	-17.66	Pass
5	3.0820	30.94	18.03	9.87	40.81	27.90	56.00	46.00	-15.19	-18.10	Pass
6	3.6540	31.20	19.18	9.87	41.07	29.05	56.00	46.00	-14.93	-16.95	Pass