

FCC 47 CFR PART 22H and 24E

Product Type : Smartphone
Applicant : HTC Corporation
Address : No. 23, Xinghua Rd., Taoyuan City, Taoyuan County 330,
Taiwan
Trade Name : HTC
Model Number : PG76210
Test Specification : FCC 47 CFR PART 22H: Oct, 2009
FCC 47 CFR PART 24E: Oct, 2009
ANSI/TIA-603-C-2004
Issue Date : Jul. 14, 2011

Issue by

A Test Lab Techno Corp.
No. 140-1, Changan Street, Bade City,
Taoyuan County 334, Taiwan R.O.C.
Tel : +886-3-2710188 / Fax : +886-3-2710190



Taiwan Accreditation Foundation accreditation number: 1330

Note: This report shall not be reproduced except in full, without the written approval of A Test Lab Techno Corp. This document may be altered or revised by A Test Lab Techno Corp. personnel only, and shall be noted in the revision section of the document. The client should not use it to claim product endorsement by TAF, or any government agencies. The test results in the report only apply to the tested sample.

Revision History

Rev.	Issue Date	Revisions	Revised By
00	Jul. 14, 2011	Initial Issue	

Verification of Compliance

Issued Date: 07/14/2011

Product Type : Smartphone
Applicant : HTC Corporation
Address : No. 23, Xinghua Rd., Taoyuan City, Taoyuan County 330,
Taiwan
Trade Name : HTC
Model Number : PG76210
FCC ID : NM8PG76210
EUT Rated Voltage : DC 5.0V, 1.0A
Test Voltage : 120 Vac / 60 Hz
Applicable : FCC 47 CFR PART 22H: Oct, 2009
Standard : FCC 47 CFR PART 24E: Oct, 2009
ANSI/TIA-603-C-2004

Test Result : Complied

Performing Lab. : A Test Lab Techno Corp.

No. 140-1, Changan Street, Bade City
Taoyuan County 334, Taiwan R.O.C.

Tel : +886-3-2710188 / Fax : +886-3-2710190

Taiwan Accreditation Foundation accreditation number:
1330



<http://www.atl-lab.com.tw/e-index.htm>

The above equipment was tested by A Test Lab Techno Corp. The test data, data evaluation, test procedures, and equipment configurations shown in this report were made in accordance with the procedures given in ANSI C63.4: 2003 and the energy emitted by the sample tested as described in this report is in compliance with the requirements of FCC Rules Part 22H, Part 24E.
The test results of this report relate only to the tested sample identified in this report.

Approved By :



(Manager)

(Miller Lee)

Reviewed By :

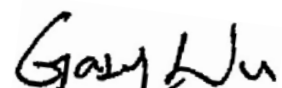

(Testing Engineer)

(Gary Wu)

TABLE OF CONTENTS

1	General Information	6
1.1.	EUT Description.....	6
1.2.	Mode of Operation.....	7
1.3.	EUT Exercise Software.....	7
1.4.	Configuration of Test System Details.....	8
1.5.	Test Site Environment.....	8
1.6.	Summary of Test Result	8
2	RF Output Power Test.....	9
2.1.	Limit	9
2.2.	Test Instruments	9
2.3.	Test Setup.....	9
2.4.	Test Procedure.....	9
2.5.	Uncertainty.....	10
2.6.	Test Result.....	10
3	Effective Radiated Power / Equivalent Isotropic Radiated Power Test	13
3.1.	Limit	13
3.2.	Test Instruments	13
3.3.	Test Setup.....	14
3.4.	Test Procedure.....	15
3.5.	Uncertainty.....	15
3.6.	Test Result.....	16
4	Occupied Bandwidth Test	17
4.1.	Limit	17
4.2.	Test Instruments	17
4.3.	Setup	17
4.4.	Test Procedure.....	18
4.5.	Uncertainty.....	18
4.6.	Test Result.....	19
5	Conducted Spurious Emission Test	25
5.1.	Limit	25
5.2.	Test Instruments	25
5.3.	Setup	25
5.4.	Test Procedure.....	26
5.5.	Uncertainty.....	26
5.6.	Test Result.....	26

6	Field Strength of Spurious Radiation Test	56
6.1.	Limit	56
6.2.	Test Instruments	56
6.3.	Setup	56
6.4.	Test Procedure.....	57
6.5.	Uncertainty.....	57
6.6.	Test Result.....	58
7	Frequency Stability (Temperature Variation) Test.....	62
7.1.	Limit	62
7.2.	Test Instruments	62
7.3.	Setup	62
7.4.	Test Procedure.....	63
7.5.	Uncertainty.....	63
7.6.	Test Result.....	64
8	Frequency Stability (Voltage Variation) Test.....	65
8.1.	Limit	65
8.2.	Test Instruments	65
8.3.	Setup	56
8.4.	Test Procedure.....	65
8.5.	Uncertainty.....	66
8.6.	Test Result.....	66
9	AC Power Conducted Emissions Test.....	67
9.1.	Limit	67
9.2.	Test Instruments	67
9.3.	Setup	67
9.4.	Test Procedure.....	68
9.5.	Uncertainty.....	68
9.6.	Test Result.....	69

1 General Information

1.1. EUT Description

Applicant		HTC Corporation			
Applicant Address		No. 23, Xinghua Rd., Taoyuan City, Taoyuan County 330, Taiwan			
Manufacturer		HTC Corporation			
Manufacturer Address		No. 23, Xinghua Rd., Taoyuan City, Taoyuan County 330, Taiwan			
Product Type		Smartphone			
Trade Name		HTC			
Model Number		PG76210			
FCC ID		NM8PG76210			
Mode	CDMA 2000, 1xRTT, 1xEVDO Rev0, 1xEVDO RevA	Band	UL Frequency (MHz)	DL Frequency (MHz)	Modulation
		Cellular	824.0 ~ 849.0	869.0 ~ 893.0	QPSK
		PCS	1850.0 ~ 1910.0	1930.0 ~ 1990.0	QPSK
Channel Control		Auto			
Type of Antenna		PIFA Antenna			
Antenna Gain (dBi)		Cellular Band: -0.5 dBi PCS Band: 1.2 dBi			
Max. RF Output power		Cellular Band: 29.78 dBm / 0.951 W PCS Band: 29.37 dBm / 0.865 W			
Max. ERP/EIRP		Cellular Band: 29.23 dBm / 0.838 W PCS Band: 27.41 dBm / 0.551 W			
Emission Designator		Cellular Band: 1M29F9W PCS Band: 1M29F9W			

1.2. Mode of Operation

ATL has verified the construction and function in typical operation. All the test modes were carried out with the EUT in normal operation, which was shown in this test report and defined as:

Test Mode
Mode 1: CDMA 2000 Cellular Band Link
Mode 2: CDMA 2000 PCS Band Link
Mode 3: CDMA 2000 1xRTT Cellular Band Link
Mode 4: CDMA 2000 1xRTT PCS Band Link
Mode 5: CDMA 2000 1xEVDO Rev0 Cellular Band Link
Mode 6: CDMA 2000 1xEVDO Rev0 PCS Band Link
Mode 7: CDMA 2000 1xEVDO RevA Cellular Band Link
Mode 8: CDMA 2000 1xEVDO RevA PCS Ban Link

Note: Regards to the frequency band operation: the lowest, middle and highest frequency of channel were selected to perform the test, then shown on this report.

Tested System Details

The types for all equipments, plus descriptions of all cables used in the tested system (including inserted cards) are:

	Product	Manufacturer	Model Number	Serial Number	Power Cord
1.	Universal Radio Communication Tester	R&S	CMU200	109369	N/A

1.3. EUT Exercise Software

1.	Setup the EUT and Base Station (CMU200) as shown on 1.4.
2.	Turn on the power of all equipment.

1.4. Configuration of Test System Details

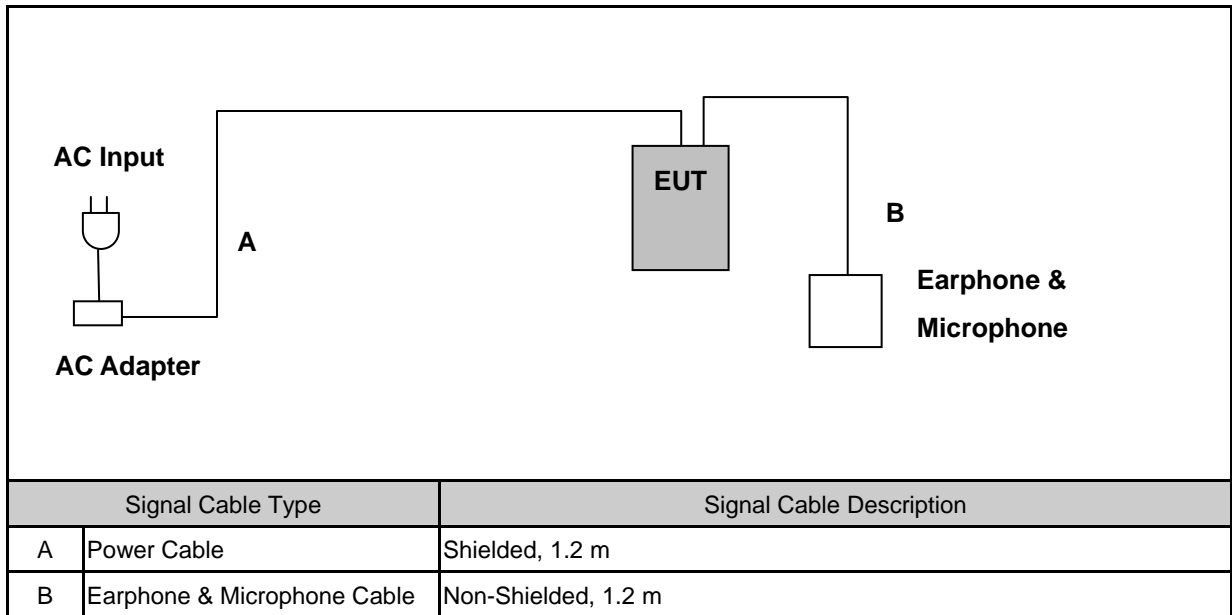

1.5. Test Site Environment

Items	Required (IEC 68-1)	Actual
Temperature (°C)	15-35	26
Humidity (%RH)	25-75	55
Barometric pressure (mbar)	860-1060	950

1.6. Summary of Test Result

Description	FCC Rule	IC Rule	Limit	Result
Conducted Output Power	§2.1046	N/A	N/A	Pass
Effective Radiated Power	§22.913(a)(2)	RSS-132(4.4) SRSP-503(5.1.3)	< 7 Watts for FCC (<6.3 Watts for IC)	Pass
Equivalent Isotropic Radiated Power	§24.232(c)	RSS-133 (6.4) SRSP-510(5.1.2)	< 2 Watts	Pass
Occupied Bandwidth	§2.1049 §22.917(a) §24.238(a)	N/A	N/A	Pass
Band Edge Measurement	§2.1051 §22.917(a) §24.238(a)	RSS-132 (4.5.1)RSS-133 (6.5.1)	< 43+10log ₁₀ (P[Watts])	Pass
Conducted Emission	§2.1051 §22.917(a) §24.238(a)	RSS-132 (4.5.1) RSS-133 (6.5.1)	< 43+10log ₁₀ (P[Watts])	Pass
Field Strength of Spurious Radiation	§2.1053 §22.917(a) §24.238(a)	RSS-132 (4.5.1) RSS-133 (6.5.1)	< 43+10log ₁₀ (P[Watts])	Pass
Frequency Stability for Temperature & Voltage	§2.1055 §22.355 §24.235	RSS-132(4.3) RSS-133(6.3)	< 2.5 ppm	Pass

2 RF Output Power Test

2.1. Limit

N/A

2.2. Test Instruments

Describe	Manufacturer	Model No.	Serial No.	Cal. Date	Remark
Universal Radio Communication Tester	ROHDE & SCHWARZ	CMU200	109369	08/10/2010	(2)
Single Channel PK Power Sensor	Agilent	N1911A	MY45101619	07/19/2010	(1)
Wideband Power Meter	Agilent	N1921A	MY45241957	07/19/2010	(1)
Test Site	ATL	TE05	TE05	N.C.R.	-----

Remark: ⁽¹⁾ Calibration period 1 year. ⁽²⁾ Calibration period 2 years.

NOTE: N.C.R. = No Calibration Request.

2.3. Test Setup

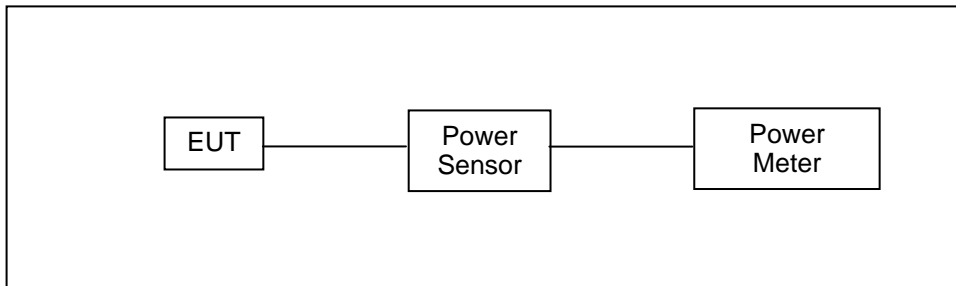

2.4. Test Procedure

The measurement is made according to ANSI/TIA-603-C-2004 as follows:

1. The transmitter output was connected to power meter and base station through power divider.
2. Set base station for EUT at GSM 850: PCL=5 and PCS 1900: PCL=0.
3. Set base station for EUT at WCDMA Band V and WCDMA Band II, power level was set to maximum.
4. Select lowest, middle, and highest channels for each band.

2.5. Uncertainty

The measurement uncertainty is defined as for RF output power measurement is 1.2 dB.

2.6. Test Result

Model Number	PG76210					
Test Item	RF Output Power					
Mode	Mode 1					
Date of Test	06/23/2011				Test Site	TE05
Band	RC/TAP (REV)	Frequency	Average Power		Peak Power	
			(dBm)	(W)	(dBm)	(W)
CDMA 2000 Cellular Band	RC1/SO55	824.70	23.66	0.232	24.05	0.254
		836.52	24.08	0.256	24.42	0.277
		848.31	23.75	0.237	23.95	0.248
	RC3/SO55	824.70	23.61	0.230	23.76	0.238
		836.52	24.00	0.251	24.14	0.259
		848.31	23.77	0.238	23.97	0.249

Model Number	PG76210					
Test Item	RF Output Power					
Mode	Mode 2					
Date of Test	06/23/2011				Test Site	TE05
Band	RC/TAP (REV)	Frequency	Average Power		Peak Power	
			(dBm)	(W)	(dBm)	(W)
CDMA 2000 PCS Band	RC1/SO55	1851.25	23.86	0.243	24.06	0.255
		1880.00	23.78	0.239	24.06	0.255
		1908.75	24.19	0.262	24.43	0.277
	RC3/SO55	1851.25	23.77	0.238	23.93	0.247
		1880.00	23.67	0.233	23.87	0.244
		1908.75	24.19	0.262	24.50	0.282

Note: The peak power testing result was used peak detector.

Model Number	PG76210					
Test Item	RF Output Power					
Mode	Mode 3					
Date of Test	06/23/2011				Test Site	TE05
Band	RC/TAP (REV)	Frequency	Average Power		Peak Power	
			(dBm)	(W)	(dBm)	(W)
CDMA 2000 1xRTT Cellular Band	RC3/SO32	824.70	23.62	0.230	23.80	0.240
		836.52	23.99	0.251	24.27	0.267
		848.31	23.69	0.234	23.82	0.241

Model Number	PG76210					
Test Item	RF Output Power					
Mode	Mode 4					
Date of Test	06/23/2011				Test Site	TE05
Band	RC/TAP (REV)	Frequency	Average Power		Peak Power	
			(dBm)	(W)	(dBm)	(W)
CDMA 2000 1xRTT PCS Band	RC3/SO32	1851.25	23.85	0.243	24.05	0.254
		1880.00	23.67	0.233	23.86	0.243
		1908.75	24.13	0.259	24.42	0.277

Model Number	PG76210					
Test Item	RF Output Power					
Mode	Mode 5					
Date of Test	06/23/2011				Test Site	TE05
Band	RTAP (kbps)	Frequency	Average Power		Peak Power	
			(dBm)	(W)	(dBm)	(W)
CDMA 2000 1xEVDO Rev0 Cellular Band	153.6	824.70	23.22	0.210	29.40	0.871
		836.52	23.32	0.215	29.78	0.951
		848.31	23.29	0.213	29.55	0.902

Note: The peak power testing result was used peak detector.

Model Number	PG76210					
Test Item	RF Output Power					
Mode	Mode 6					
Date of Test	06/23/2011				Test Site	TE05
Band	RC/TAP (REV)	Frequency	Average Power		Peak Power	
			(dBm)	(W)	(dBm)	(W)
CDMA 2000 1xEVDO Rev0 PCS Band	153.6	1851.25	23.61	0.230	29.37	0.865
		1880.00	23.59	0.229	29.33	0.857
		1908.75	23.59	0.229	29.29	0.849

Model Number	PG76210					
Test Item	RF Output Power					
Mode	Mode 7					
Date of Test	06/23/2011				Test Site	TE05
Band	RETAP Payload size	Frequency	Average Power		Peak Power	
			(dBm)	(W)	(dBm)	(W)
CDMA 2000 1xEVDO RevA Cellular Band	4096	824.70	23.46	0.222	28.75	0.750
		836.52	23.56	0.227	29.32	0.855
		848.31	23.27	0.212	29.68	0.929

Model Number	PG76210					
Test Item	RF Output Power					
Mode	Mode 8					
Date of Test	06/23/2011				Test Site	TE05
Band	RETAP Payload size	Frequency	Average Power		Peak Power	
			(dBm)	(W)	(dBm)	(W)
CDMA 2000 1xEVDO RevA PCS Band	4096	1851.25	23.01	0.200	27.68	0.586
		1880.00	23.02	0.200	28.01	0.632
		1908.75	23.01	0.200	28.19	0.659

Note: The peak power testing result was used peak detector.

3 Effective Radiated Power / Equivalent Isotropic Radiated Power Test

3.1. Limit

For FCC Part 22.913(a)(2): The ERP of mobile transmitters and auxiliary test transmitters must not exceed 7 Watts.

For FCC Part 24.232(b): The EIRP of mobile transmitters and auxiliary test transmitters must not exceed 2 Watts.

3.2. Test Instruments

3 Meter Chamber					
Equipment	Manufacturer	Model Number	Serial Number	Cal. Date	Remark
RF Pre-selector	Agilent	N9039A	MY46520256	01/18/2011	(2)
Spectrum Analyzer	Agilent	E4446A	MY46180578	01/18/2011	(1)
Pre Amplifier	Agilent	8449B	3008A02237	02/23/2011	(1)
Pre Amplifier	Agilent	8447D	2944A10961	02/23/2011	(1)
Bi-log Antenna	SCHWARZBECK MESS-ELEKTRONIK	VULB9163	9163-270	08/02/2010	(1)
Horn Antenna	SCHWARZBECK MESS-ELEKTRONIK	BBHA9120D	9120D-550	06/29/2010	(1)
Horn Antenna	SCHWARZBECK MESS-ELEKTRONIK	BBHA9170	9170-320	06/29/2010	(1)
Test Site	ATL	TE01	888001	07/30/2010	(1)

Remark: ⁽¹⁾ Calibration period 1 year. ⁽²⁾ Calibration period 2 years.

NOTE: N.C.R. = No Calibration Request.

3.3. Test Setup

Below 1 GHz

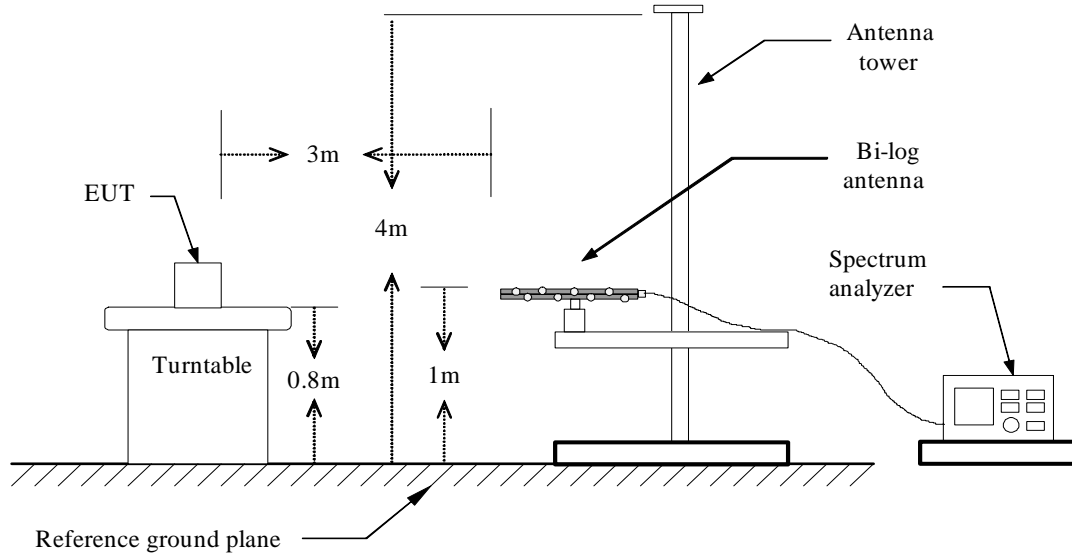

Above 1 GHz

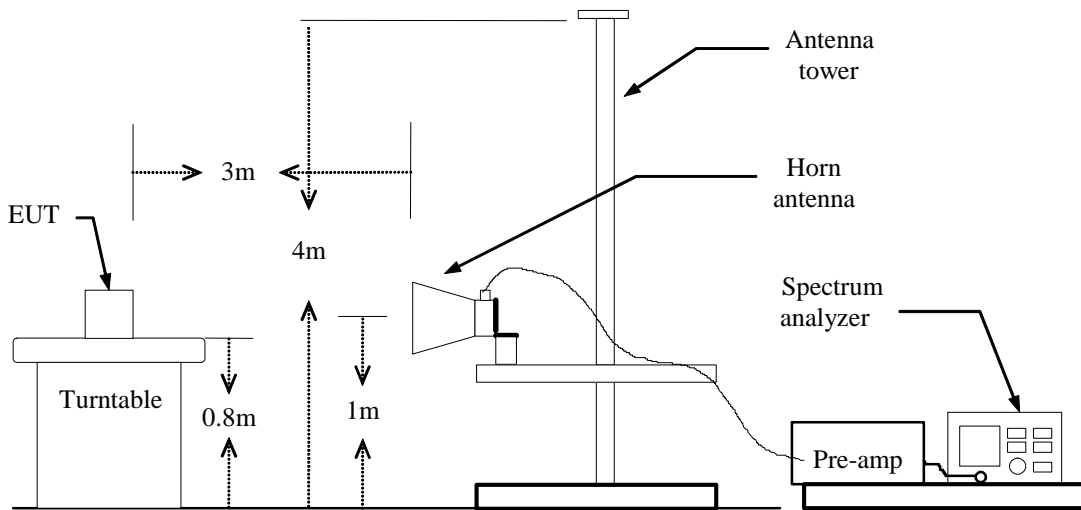

For Substituted Method Test Set-UP

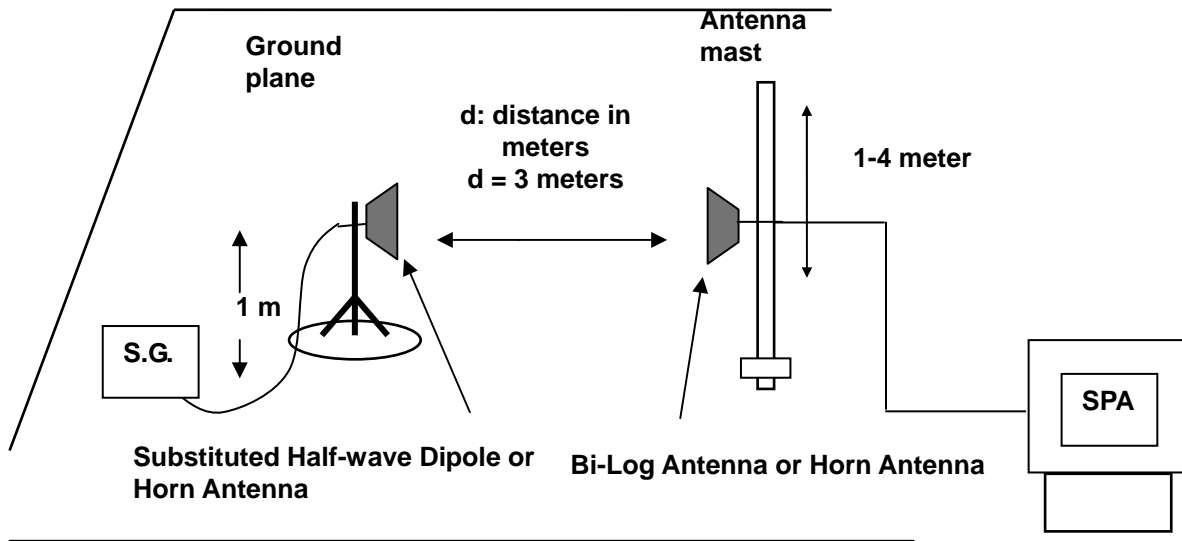

3.4. Test Procedure

The measurement is made according to ANSI/TIA-603-C-2004 as follows:

The EUT was placed on a non-conductive turntable using a non-conductive support. The radiated emission at the fundamental frequency was measured at 3 m with a test antenna and EMI spectrum analyzer.

During the measurement of the EUT, the resolution bandwidth was set to 3MHz and the average bandwidth was set to 3MHz. The highest emission was recorded with the rotation of the turntable and the lowering of the test antenna. The reading was recorded and the field strength (E in dBuV/m) was calculated.

ERP in frequency band 824-849MHz, and EIRP in frequency band 1851.25 –1910MHz were measured using a substitution method. The EUT was replaced by half-wave dipole (824-849MHz) or horn antenna (1851.25-1910MHz) connected to a signal generator. The spectrum analyzer reading was recorded and ERP/EIRP was calculated as follows:

$$\text{ERP} = \text{S.G. output (dBm)} + \text{Antenna Gain (dBd)} - \text{Cable (dB)}$$

$$\text{EIRP} = \text{S.G. output (dBm)} + \text{Antenna Gain (dBi)} - \text{Cable (dB)}$$

3.5. Uncertainty

The measurement uncertainty is defined as for Field Strength of Spurious Radiation measurement is ± 3.072 dB.

3.6. Test Result

Model Number	PG76210						
Test Item	ERP/EIRP						
Date of Test	06/23/2011				Test Site		TC03
Mode	Frequency (MHz)	Ant. Polar.	Read Level (dBm)	Correction factor (dBm)	ERP		Limit
					(dBm)	(W)	
5	824.7	H	-10.96	40.19	29.23	0.838	< 7W
		V	-12.43	40.00	27.57	0.571	< 7W
	837.0	H	-12.57	39.65	27.08	0.511	< 7W
		V	-12.56	41.08	28.52	0.711	< 7W
	848.3	H	-12.64	41.77	29.13	0.818	< 7W
		V	-12.67	39.32	26.65	0.462	< 7W

Model Number	PG76210						
Test Item	ERP/EIRP						
Date of Test	06/23/2011				Test Site		TC03
Mode	Frequency (MHz)	Ant. Polar.	Read Level (dBm)	Correction factor (dBm)	EIRP		Limit
					(dBm)	(W)	
6	1851.25	H	15.49	10.43	25.92	0.391	< 2W
		V	17.98	8.27	26.25	0.422	< 2W
	1880.00	H	16.97	10.44	27.41	0.551	< 2W
		V	17.94	8.50	26.44	0.441	< 2W
	1908.75	H	16.72	10.44	27.16	0.520	< 2W
		V	17.87	8.72	26.59	0.456	< 2W

Note: 1. ERP/EIRP = Read Level + Correction factor.

2. For WCDMA signals, a peak detector is used with RBW = VBW = 5MHz.

3. For AMPS, GSM, and NADC TDMA signals, a peak detector is used, with RBW = VBW= 3 MHz.

4 Occupied Bandwidth Test

4.1. Limit

The Occupied Bandwidth Limit:

N/A.

The Band Edge Limit:

The power of any emission outside of the authorized operating frequency ranges must be attenuated below the transmitting power (P) by a factor of at least $43 + 10\log(P)$ dB.

4.2. Test Instruments

Describe	Manufacturer	Model No.	Serial No.	Cal. Date	Remark
Spectrum Analyzer	Agilent	E4445A	MY46181986	05/16/2011	(2)
Universal Radio Communication Tester	ROHDE & SCHWARZ	CMU200	109369	08/10/2010	(2)
Attenuator	RADIALL	R41572000	0603033073	N.C.R.	-----
Power divider	Agilent	87302C	3239A00760	N.C.R.	-----
Test Site	ATL	TE05	TE05	N.C.R.	-----

Remark: ⁽¹⁾ Calibration period 1 year. ⁽²⁾ Calibration period 2 years.

NOTE: N.C.R. = No Calibration Request.

4.3. Setup

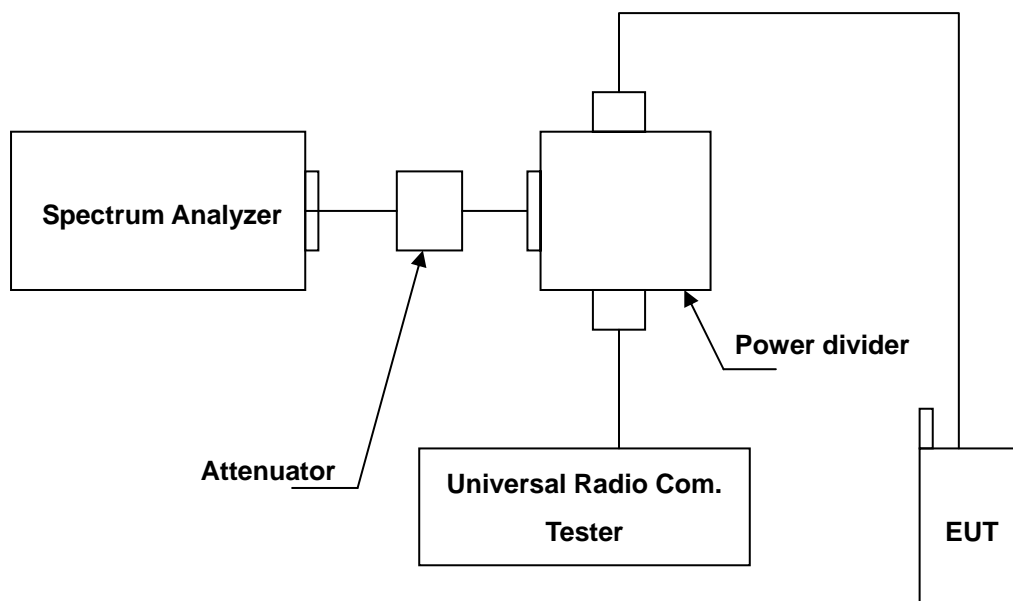

4.4. Test Procedure

The measurement is made according to FCC rules part 22 and 24:

1. The EUT was connected to Spectrum Analyzer and Base Station via power divider.
2. The occupied bandwidth of middle channel for the highest and lowest RF powers was measured.
3. The band edge of low and high channels for the highest RF powers within the transmitting frequency band were measured. Setting RBW as roughly BW/100.
4. The band edge setting:
 - a. RB=3 kHz; VB=3 kHz for GSM 850 and PCS 1900.
 - b. RB=100 kHz; VB=100 kHz for WCDMA Band V and WCDMA Band II.
 - c. RB=30 kHz; VB=300 kHz for CDMA Cellular Band and PCS Band.

4.5. Uncertainty

The measurement uncertainty is defined as $\pm 10\text{Hz}$

4.6. Test Result

99% Occupied Bandwidth

Model Number	PG76210		
Test Item	Occupied Bandwidth		
Test Mode	Mode 5		
Date of Test	06/23/2011	Test Site	TE05
Channel No.	Frequency (MHz)	99% Bandwidth (MHz)	Note
1013	824.7	1.2866	RBW:30KHz , VBW:300KHz
384	836.6	1.2796	RBW:30KHz , VBW:300KHz
777	848.3	1.2849	RBW:30KHz , VBW:300KHz

Figure Channel 1013

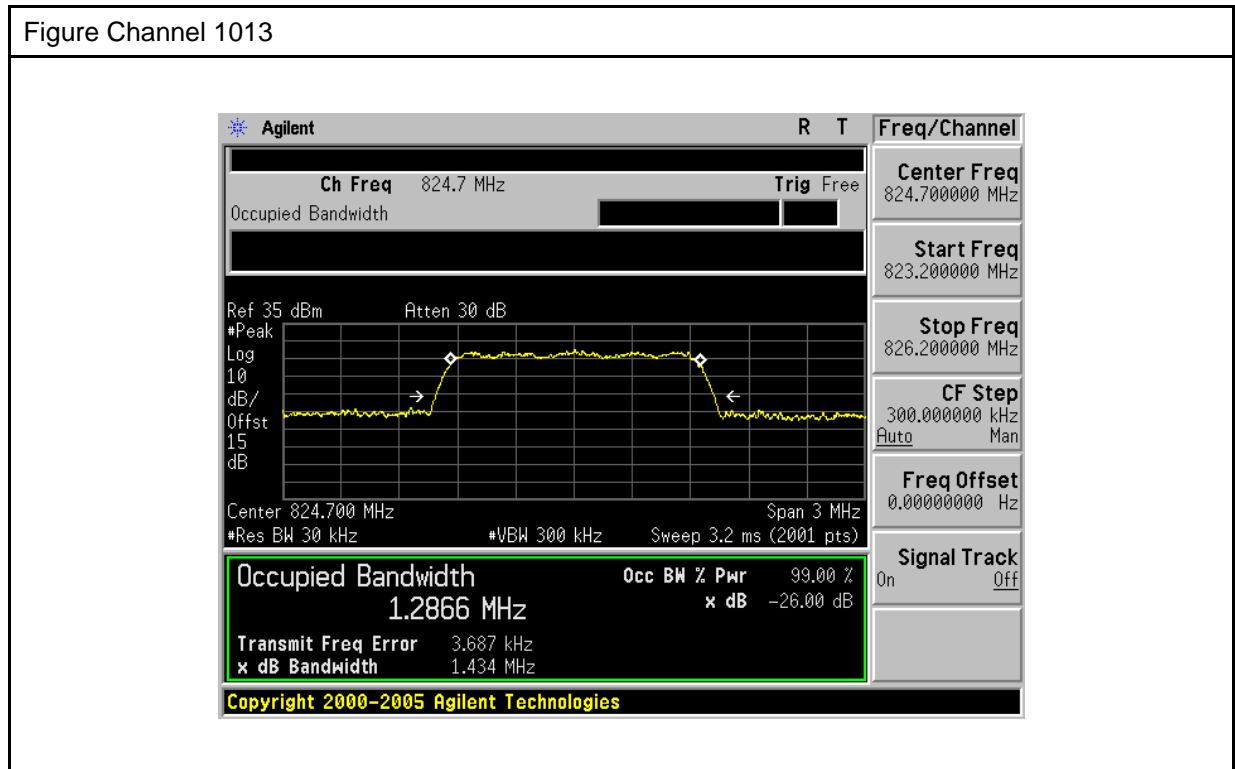

Figure Channel 384

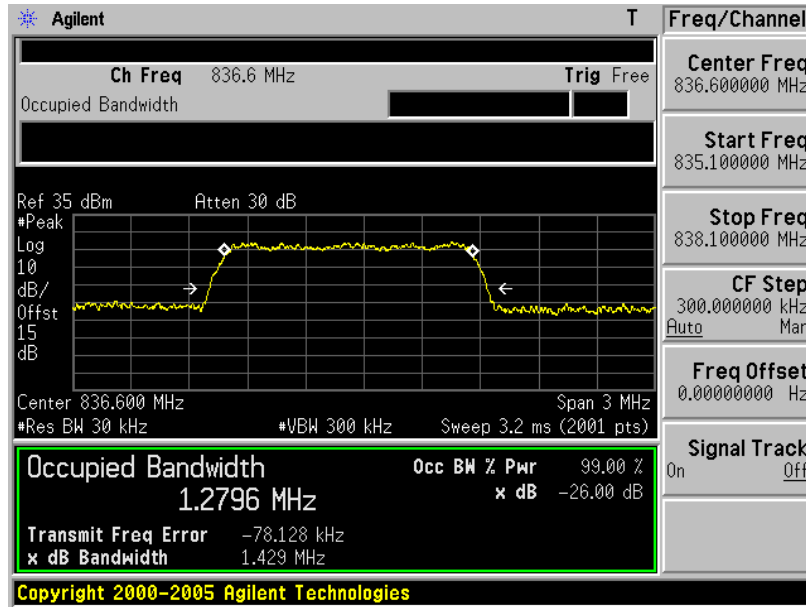
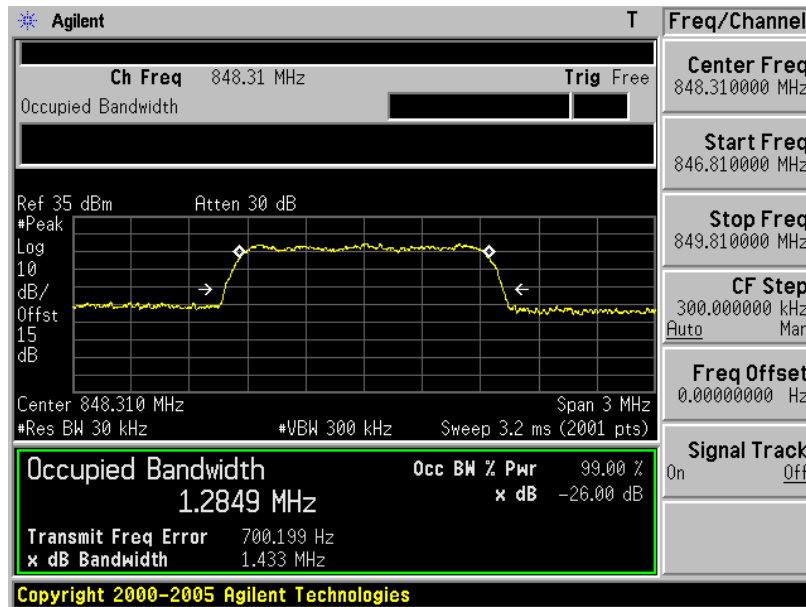

Figure Channel 777



Model Number	PG76210		
Test Item	Occupied Bandwidth		
Test Mode	Mode 6		
Date of Test	06/23/2011	Test Site	TE05
Channel No.	Frequency (MHz)	99% Bandwidth (kHz)	Note
25	1851.25	1.2908	RBW:30KHz , VBW:300KHz
600	1880.00	1.2904	RBW:30KHz , VBW:300KHz
1175	1908.75	1.2805	RBW:30KHz , VBW:300KHz

Figure Channel 25

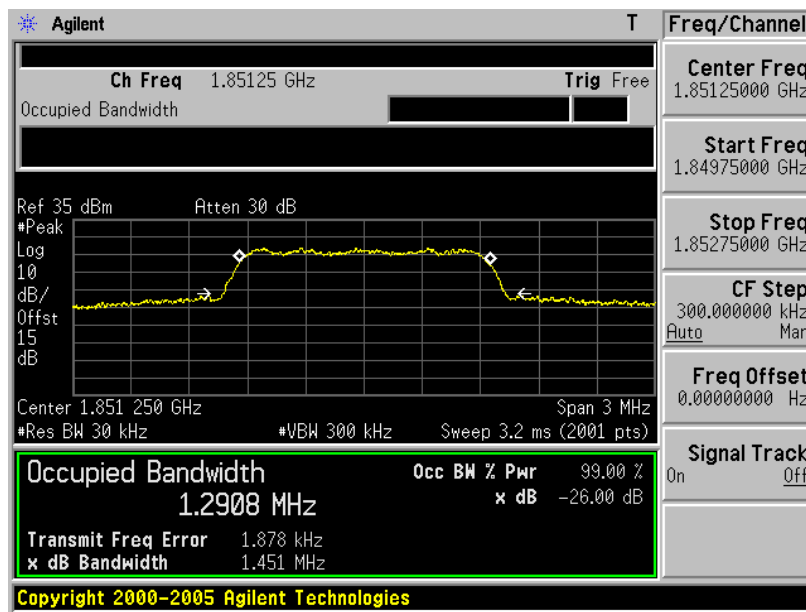

Figure Channel 600

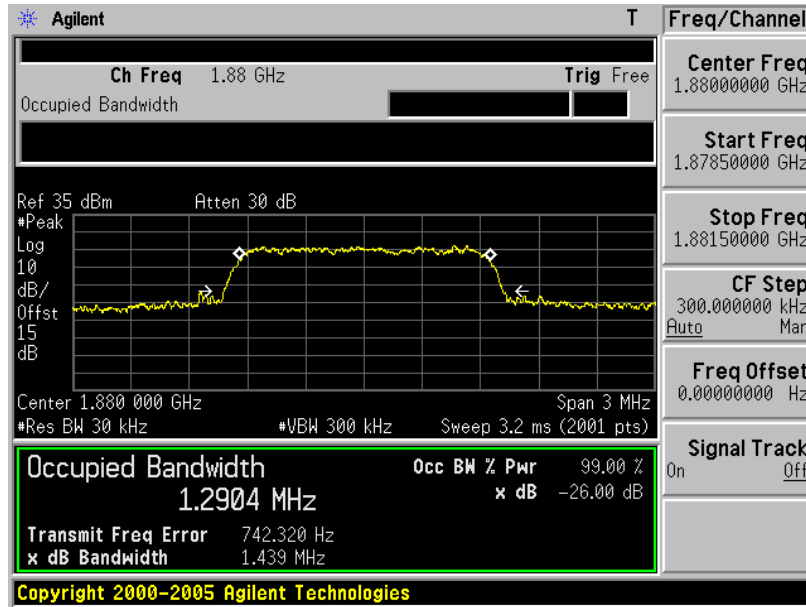
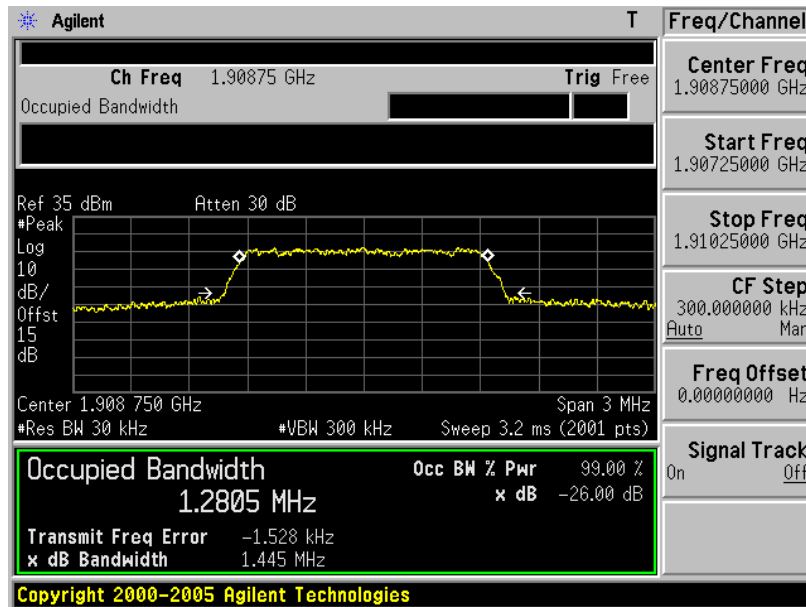
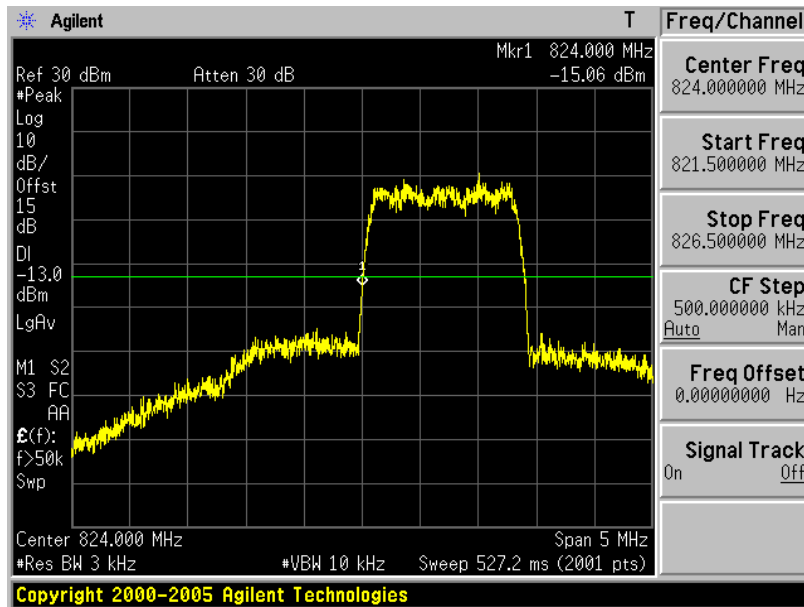
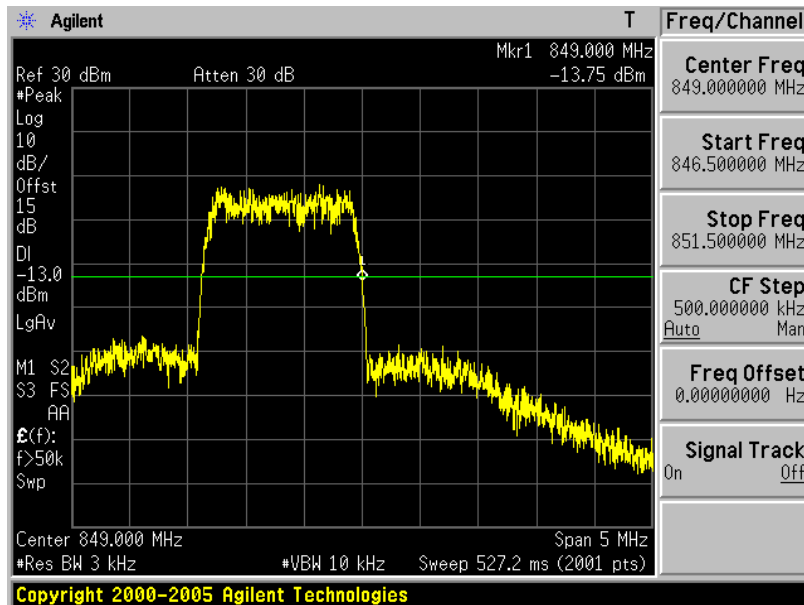

Figure Channel 1175



Band Edge

Model Number	PG76210				
Test Item	Band Edge				
Test Mode	Mode 5				
Date of Test	06/23/2011		Test Site	TE05	
Band	Channel	Frequency (MHz)	Bandwidth (dBm)	Limit (dBm)	Result
Lower	1013	824.0000	-15.06	-13	Pass
Higher	777	849.0000	-13.75	-13	Pass

Lower Band

Higher Band

Model Number	PG76210				
Test Item	Band Edge				
Test Mode	Mode 6				
Date of Test	06/23/2011		Test Site	TE05	
Band	Channel	Frequency (MHz)	Bandwidth (dBm)	Limit (dBm)	Result
Lower	25	1850.000	-25.14	-13	Pass
Higher	1175	1910.000	-29.02	-13	Pass

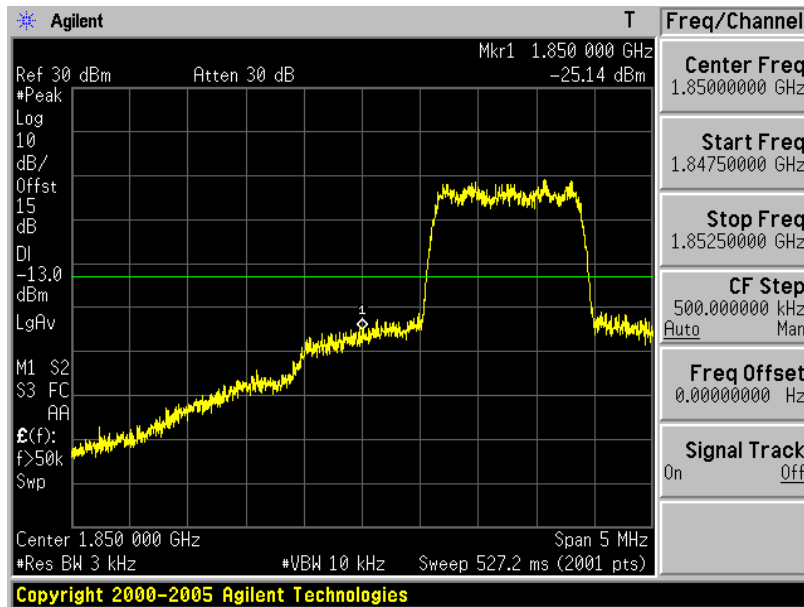
Lower Band

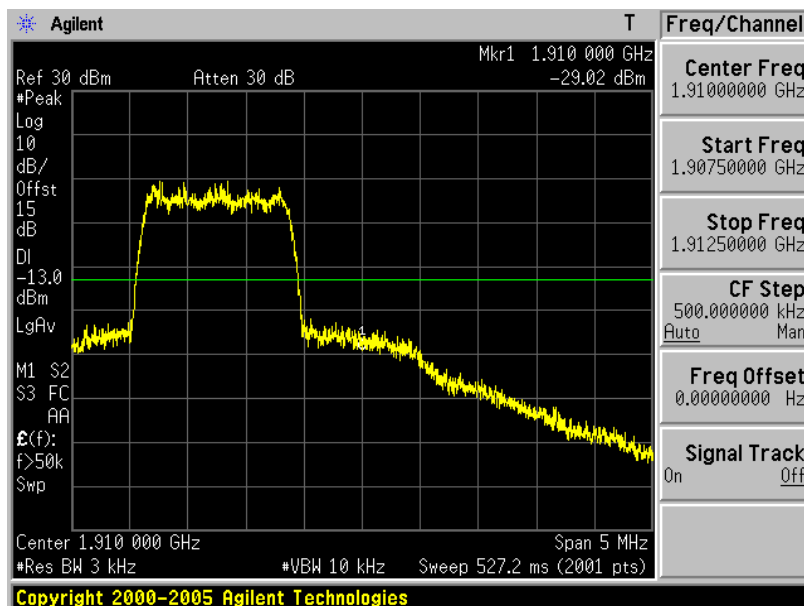

Higher Band



5 Conducted Spurious Emission Test

5.1. Limit

The power of any emission outside of the authorized operating frequency ranges must be attenuated below the transmitting power (P) by a factor of at least $43 + 10\log(P)$ dB.

5.2. Test Instruments

Describe	Manufacturer	Model No.	Serial No.	Cal. Date	Remark
Spectrum Analyzer	Agilent	E4445A	MY46181986	05/16/2011	(²)
Universal Radio Communication Tester	ROHDE & SCHWARZ	CMU200	109369	08/10/2010	(²)
Attenuator	RADIALL	R41572000	0603033073	N.C.R.	-----
Power divider	Agilent	87302C	3239A00760	N.C.R.	-----
Test Site	ATL	TE02	TE02	N.C.R.	-----

Remark: (¹) Calibration period 1 year. (²) Calibration period 2 years.

NOTE: N.C.R. = No Calibration Request.

5.3. Setup

Below 2.8GHz

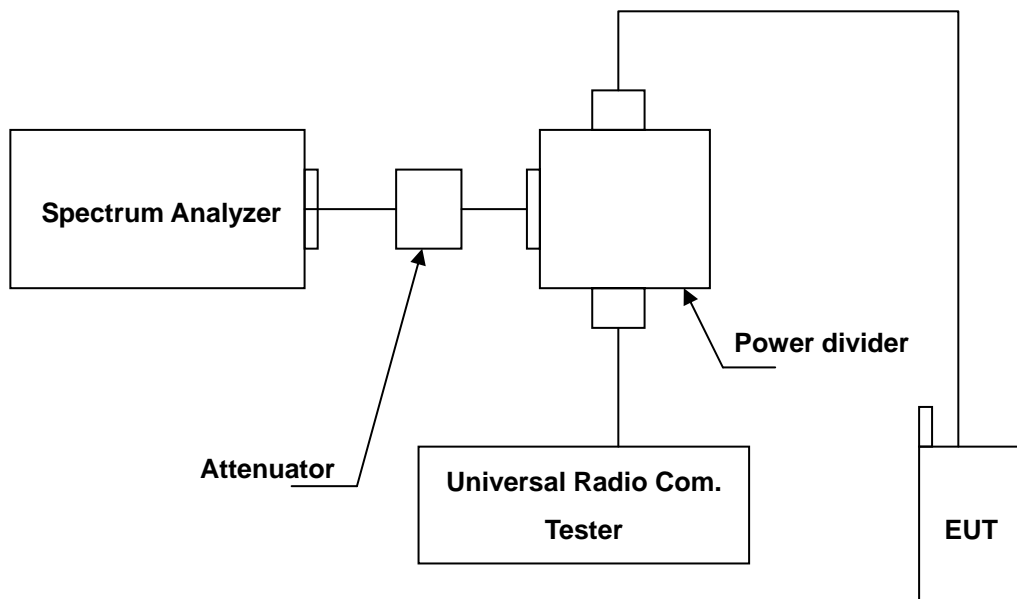

Above 2.8GHz

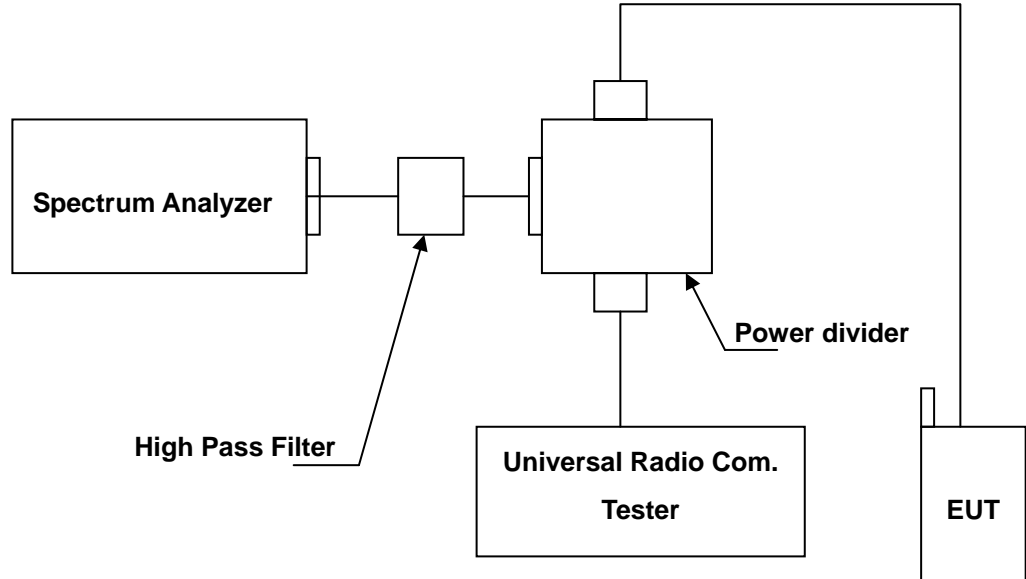

5.4. Test Procedure

1. The EUT was connected to Spectrum Analyzer and Base Station via power divider.
2. The middle channel for the highest RF power within the transmitting frequency was measured.
3. The conducted spurious emission for the whole frequency range was taken.
4. Test setting at GSM 850 RB>100 kHz, VB>100 kHz; PCS 1900 RB>1MHz, VB>1MHz.

5.5. Uncertainty

The measurement uncertainty is evaluated as ± 2.24 dB.

5.6. Test Result

Model Number	PG76210		
Test Item	Conducted Spurious Emission		
Mode	Mode 5 / Mode 6		
Date of Test	06/23/2011	Test Site	TE02

File: PG76210(CH1013)

Data :#1

Date: 2011/6/23

Time: 下午 02:14:41

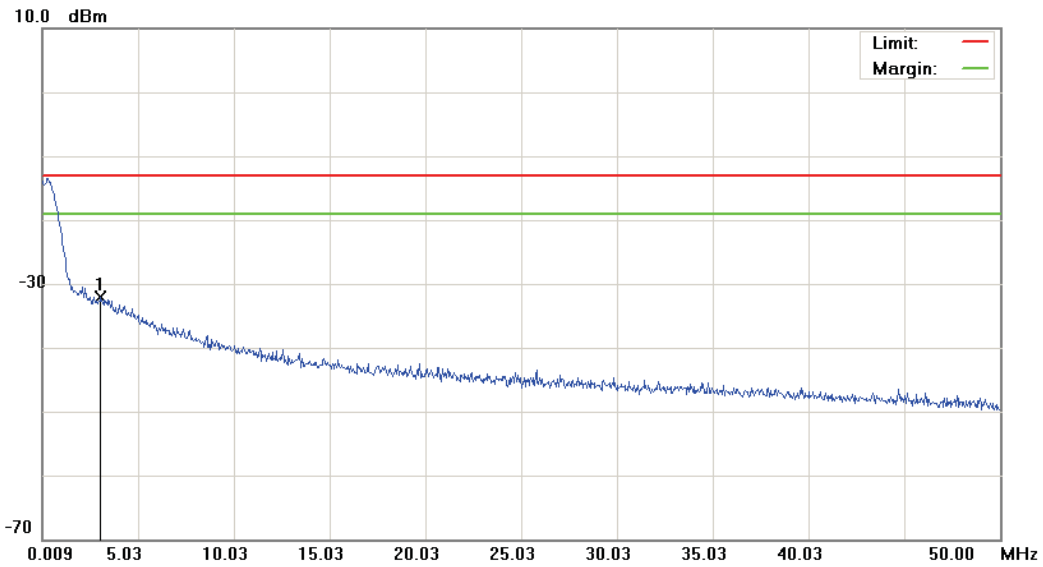

Site: : RF Conducted	Polarization: <i>Conducted po</i>	Temperature: 26 °C
Limit: FCC Part 22 conducted(9k-12.75G)	Power: AC 120V/60Hz	Humidity: 55 %
EUT: Smartphone	Distance:	RBW: 1000 KHz VBW: 1000 KHz
M/N: PG76210		
Mode: 5		
Note: CH1013		

No.	Mk.	Freq. MHz	Reading Level dBm	Correct Factor dB	Measure- ment dBm	Limit dBm	Over dB	Antenna Height cm	Table Degree degree	Comment
1	*	3.0585	-62.55	30.42	-32.13	-13.00	-19.13	peak		

*:Maximum data x:Over limit !:over margin

File: PG76210(CH1013)

Data :#2

Date: 2011/6/23

Time: 下午 02:15:05

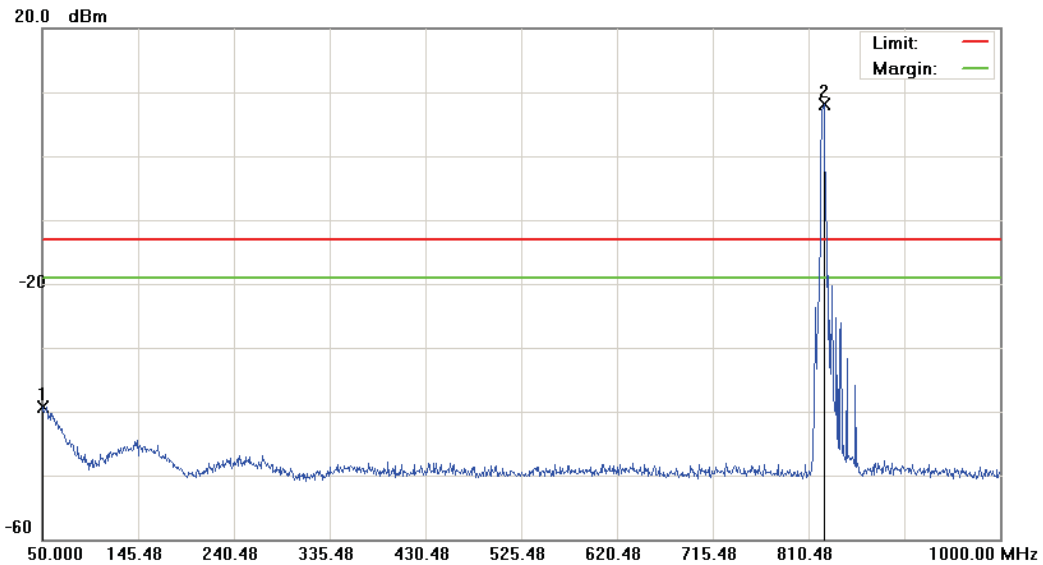

Site: : RF Conducted	Polarization: <i>Conducted po</i>	Temperature: 26 °C
Limit: FCC Part 22 conducted(9k-12.75G)	Power: AC 120V/60Hz	Humidity: 55 %
EUT: Smartphone	Distance:	RBW: 1000 KHz VBW: 1000 KHz
M/N: PG76210		
Mode: 5		
Note: CH1013		

No.	Mk.	Freq. MHz	Reading Level dBm	Correct Factor dB	Measure- ment dBm	Limit dBm	Over dB	Antenna Height cm	Table Degree degree	Comment
1		50.4750	-53.89	14.61	-39.28	-13.00	-26.28	peak		
2	*	825.2000	4.29	3.84	8.13	-13.00	21.13	peak		TX

*:Maximum data x:Over limit !:over margin

File: PG76210(CH1013)

Data :#3

Date: 2011/6/23

Time: 下午 02:34:24

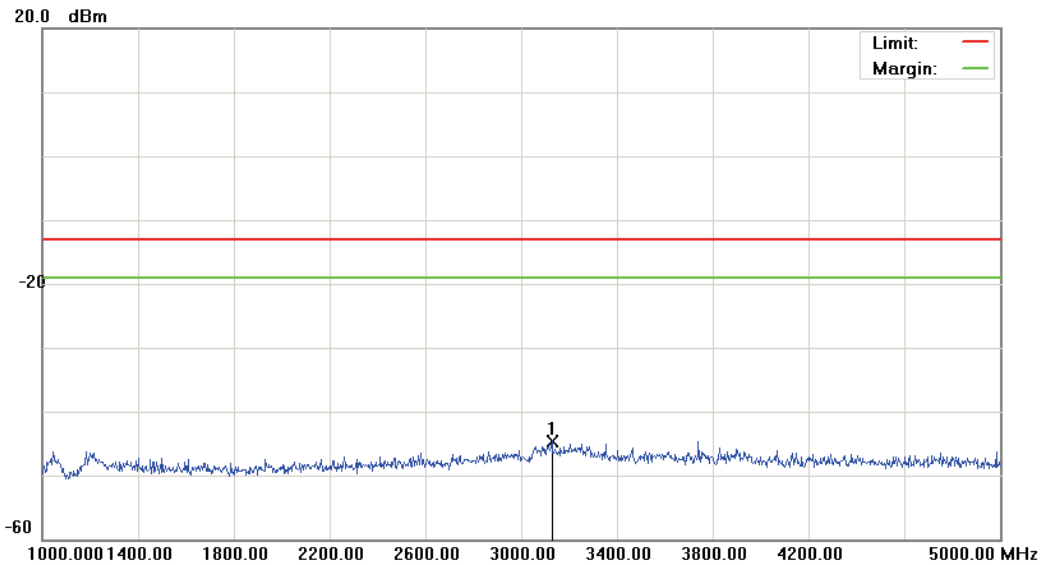

Site: RF Conducted	Polarization: <i>Conducted po</i>	Temperature: 26 °C
Limit: FCC Part 22 conducted(9k-12.75G)	Power: AC 120V/60Hz	Humidity: 55 %
EUT: Smartphone	Distance:	RBW: 1000 KHz VBW: 1000 KHz
M/N: PG76210		
Mode: 5		
Note: CH1013		

No.	Mk.	Freq. MHz	Reading Level dBm	Correct Factor dB	Measure- ment dBm	Limit dBm	Over dB	Antenna Height cm	Table Degree degree	Comment
1	*	3130.000	-49.16	4.56	-44.60	-13.00	-31.60	peak		

*:Maximum data x:Over limit !:over margin

File: PG76210(CH1013)

Data :#4

Date: 2011/6/23

Time: 下午 02:34:47

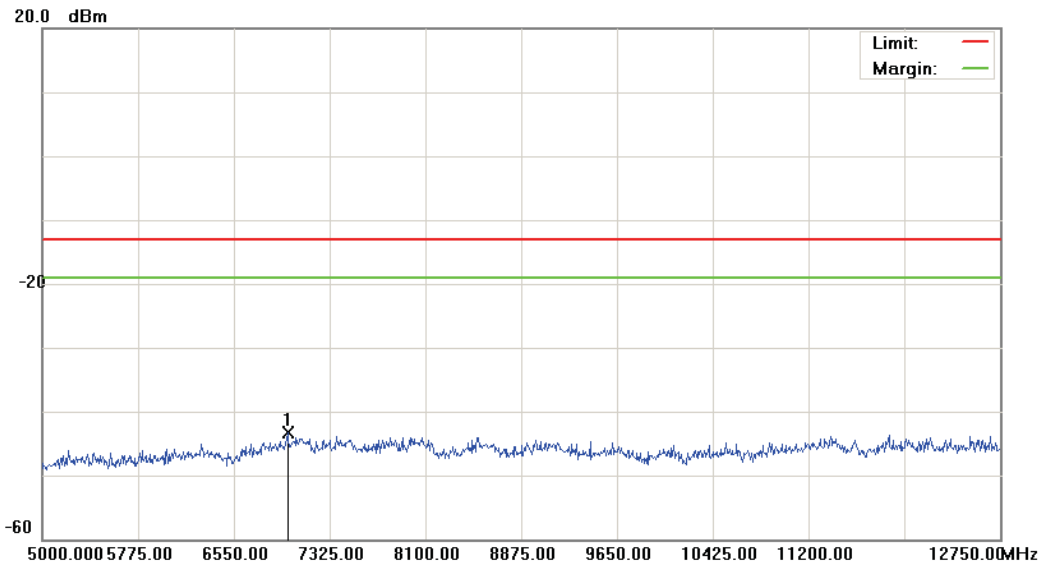

Site: : RF Conducted	Polarization: <i>Conducted po</i>	Temperature: 26 °C
Limit: FCC Part 22 conducted(9k-12.75G)	Power: AC 120V/60Hz	Humidity: 55 %
EUT: Smartphone	Distance:	RBW: 1000 KHz VBW: 1000 KHz
M/N: PG76210		
Mode: 5		
Note: CH1013		

No.	Mk.	Freq. MHz	Reading Level dBm	Correct Factor dB	Measure- ment dBm	Limit dBm	Over dB	Antenna Height cm	Table Degree degree	Comment
1	*	6987.875	-48.29	4.95	-43.34	-13.00	-30.34	peak		

*:Maximum data x:Over limit !:over margin

File: PG76210(CH384)

Data :#1

Date: 2011/6/23

Time: 下午 02:17:24

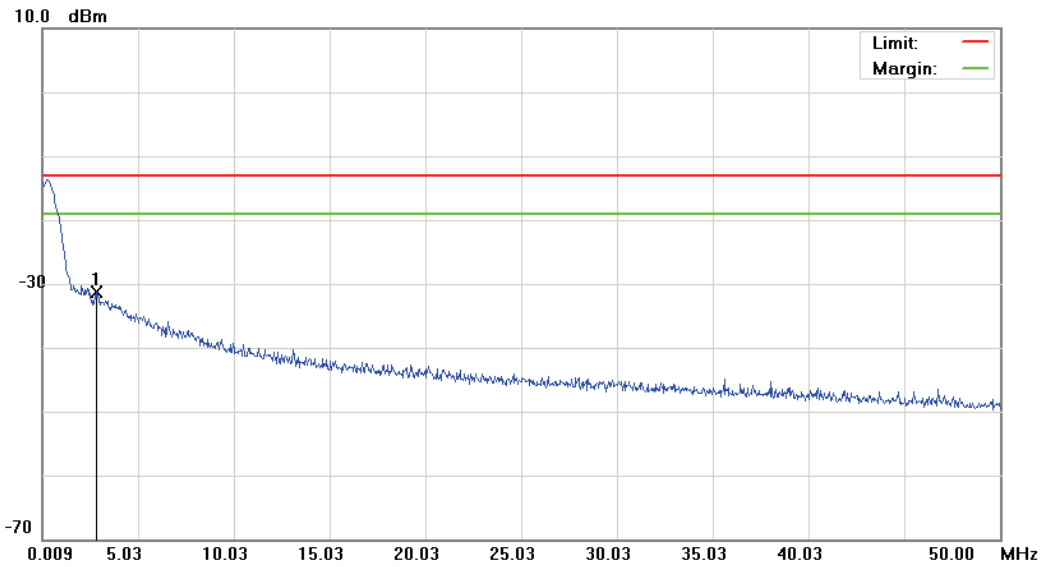

Site: : RF Conducted	Polarization: <i>Conducted po</i>	Temperature: 26 °C
Limit: FCC Part 22 conducted(9k-12.75G)	Power: AC 120V/60Hz	Humidity: 55 %
EUT: Smartphone	Distance:	RBW: 1000 KHz VBW: 1000 KHz
M/N: PG76210		
Mode: 5		
Note: CH384		

No.	Mk.	Freq. MHz	Reading Level dBm	Correct Factor dB	Measure- ment dBm	Limit dBm	Over dB	Antenna Height cm	Table Degree degree	Comment
1	*	2.8085	-61.93	30.59	-31.34	-13.00	-18.34	peak		

*:Maximum data x:Over limit !:over margin

File: PG76210(CH384)

Data :#2

Date: 2011/6/23

Time: 下午 02:17:48

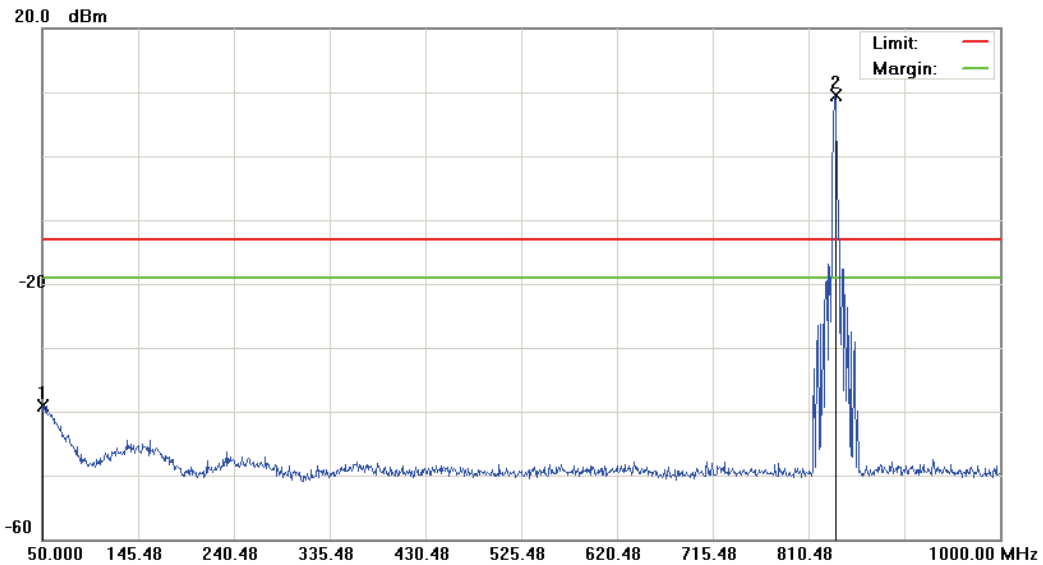

Site: : RF Conducted	Polarization: <i>Conducted po</i>	Temperature: 26 °C
Limit: FCC Part 22 conducted(9k-12.75G)	Power: AC 120V/60Hz	Humidity: 55 %
EUT: Smartphone	Distance:	RBW: 1000 KHz VBW: 1000 KHz
M/N: PG76210		
Mode: 5		
Note: CH384		

No.	Mk.	Freq. MHz	Reading Level dBm	Correct Factor dB	Measure- ment dBm	Limit dBm	Over dB	Antenna Height cm	Table Degree degree	Comment
1		50.4750	-53.63	14.61	-39.02	-13.00	-26.02	peak		
2	*	836.1250	5.46	3.96	9.42	-13.00	22.42	peak		TX

*:Maximum data x:Over limit !:over margin

File: PG76210(CH384)

Data :#3

Date: 2011/6/23

Time: 下午 02:40:12

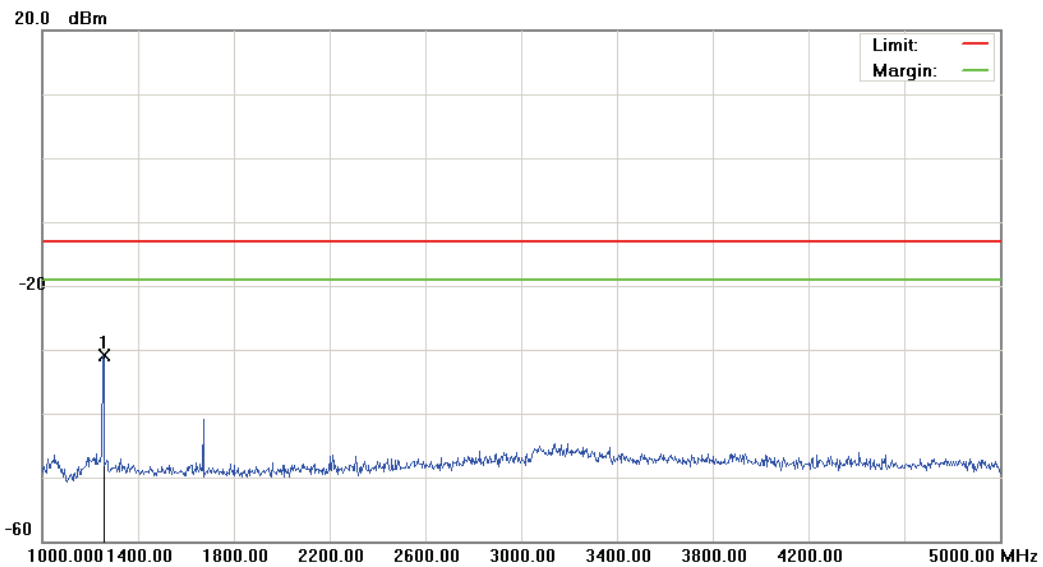

Site: : RF Conducted	Polarization: <i>Conducted po</i>	Temperature: 26 °C
Limit: FCC Part 22 conducted(9k-12.75G)	Power: AC 120V/60Hz	Humidity: 55 %
EUT: Smartphone	Distance:	RBW: 1000 KHz VBW: 1000 KHz
M/N: PG76210		
Mode: 5		
Note: CH384		

No.	Mk.	Freq. MHz	Reading Level dBm	Correct Factor dB	Measure- ment dBm	Limit dBm	Over dB	Antenna Height cm	Table Degree degree	Comment
1	*	1254.000	-36.44	5.46	-30.98	-13.00	-17.98	peak		

*:Maximum data x:Over limit !:over margin

File: PG76210(CH384)

Data :#4

Date: 2011/6/23

Time: 下午 02:40:35

20.0 dBm

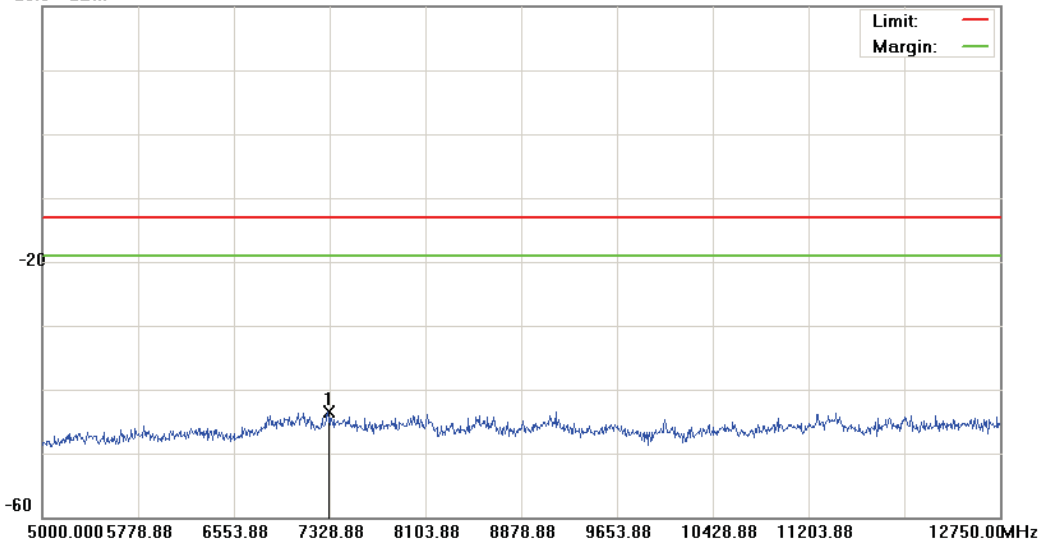

Site: : RF Conducted	Polarization: <i>Conducted po</i>	Temperature: 26 °C
Limit: FCC Part 22 conducted(9k-12.75G)	Power: AC 120V/60Hz	Humidity: 55 %
EUT: Smartphone	Distance:	RBW: 1000 KHz VBW: 1000 KHz
M/N: PG76210		
Mode: 5		
Note: CH384		

No.	Mk.	Freq. MHz	Reading Level dBm	Correct Factor dB	Measure- ment dBm	Limit dBm	Over dB	Antenna Height cm	Table Degree degree	Comment
1	*	7313.375	-48.62	5.13	-43.49	-13.00	-30.49	peak		

*:Maximum data x:Over limit !:over margin

File: PG76210(CH777)

Data :#1

Date: 2011/6/23

Time: 下午 02:20:04

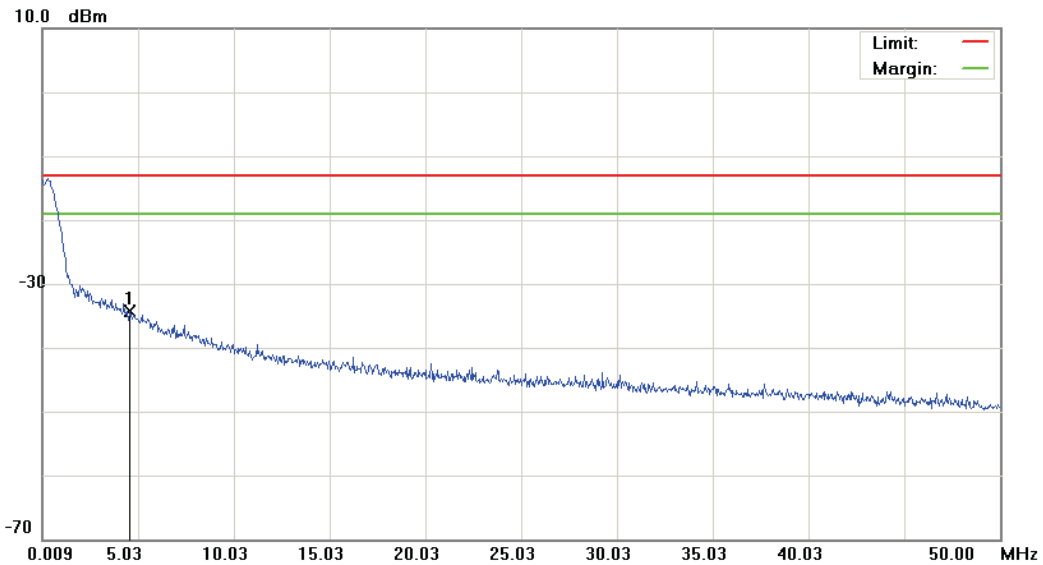

Site: : RF Conducted	Polarization: <i>Conducted po</i>	Temperature: 26 °C
Limit: FCC Part 22 conducted(9k-12.75G)	Power: AC 120V/60Hz	Humidity: 55 %
EUT: Smartphone	Distance:	RBW: 1000 KHz VBW: 1000 KHz
M/N: PG76210		
Mode: 5		
Note: CH777		

No.	Mk.	Freq. MHz	Reading Level dBm	Correct Factor dB	Measure- ment dBm	Limit dBm	Over dB	Antenna Height cm	Table Degree degree	Comment
1	*	4.5582	-63.20	28.82	-34.38	-13.00	-21.38	peak		

*:Maximum data x:Over limit !:over margin

File: PG76210(CH777)

Data :#2

Date: 2011/6/23

Time: 下午 02:20:28

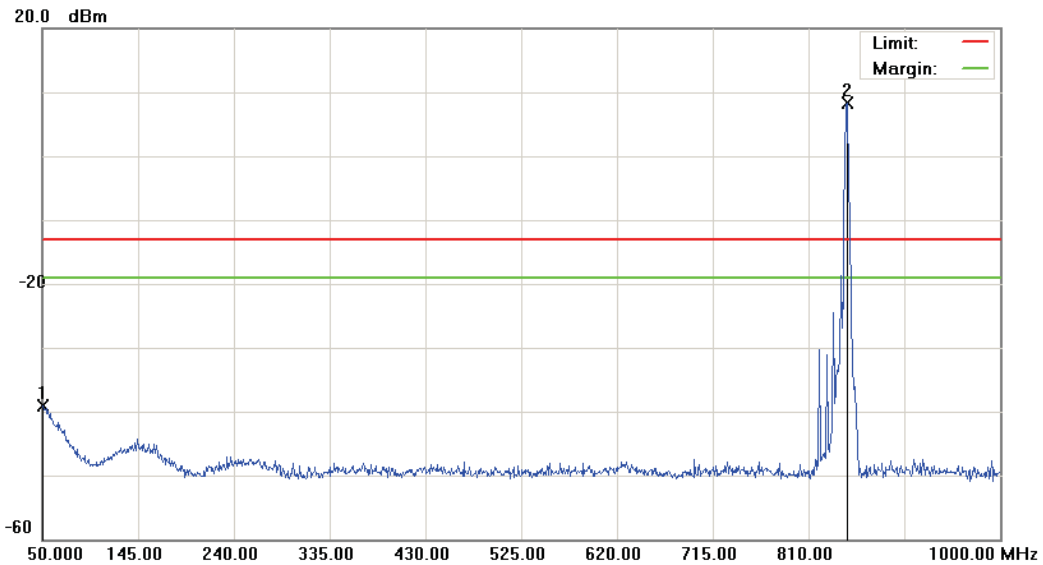

Site: : RF Conducted	Polarization: <i>Conducted po</i>	Temperature: 26 °C
Limit: FCC Part 22 conducted(9k-12.75G)	Power: AC 120V/60Hz	Humidity: 55 %
EUT: Smartphone	Distance:	RBW: 1000 KHz VBW: 1000 KHz
M/N: PG76210		
Mode: 5		
Note: CH777		

No.	Mk.	Freq. MHz	Reading Level dBm	Correct Factor dB	Measure- ment dBm	Limit dBm	Over dB	Detector	Antenna Height cm	Table Degree degree	Comment
1		50.0000	-53.79	14.69	-39.10	-13.00	-26.10	peak			
2	*	848.0000	4.26	3.98	8.24	-13.00	21.24	peak			TX

*:Maximum data x:Over limit !:over margin

File: PG76210(CH777)

Data :#3

Date: 2011/6/23

Time: 下午 02:41:51

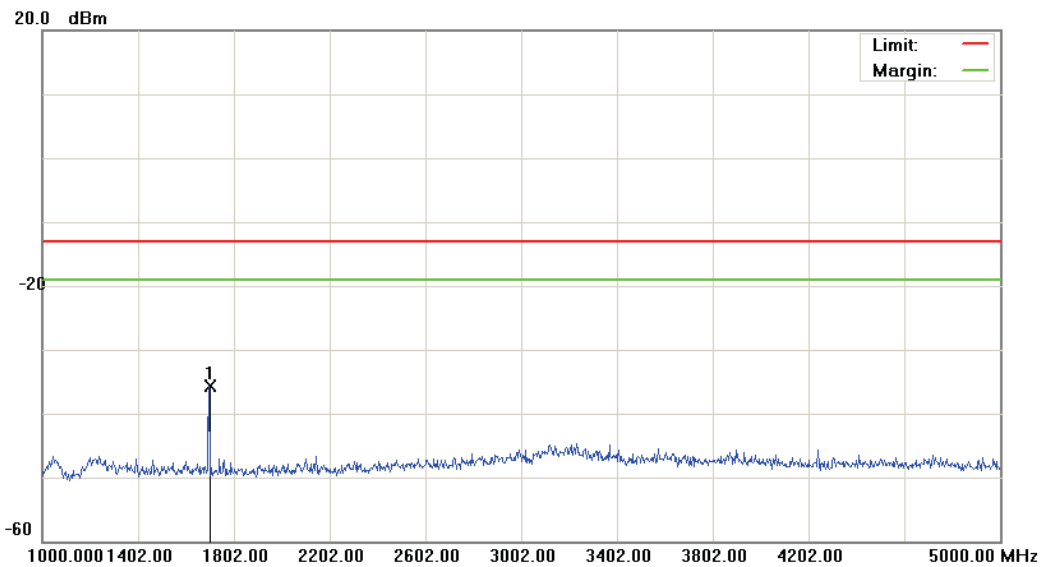

Site: : RF Conducted	Polarization: <i>Conducted po</i>	Temperature: 26 °C
Limit: FCC Part 22 conducted(9k-12.75G)	Power: AC 120V/60Hz	Humidity: 55 %
EUT: Smartphone	Distance:	RBW: 1000 KHz VBW: 1000 KHz
M/N: PG76210		
Mode: 5		
Note: CH777		

No.	Mk.	Freq. MHz	Reading Level dBm	Correct Factor dB	Measure- ment dBm	Limit dBm	Over dB	Antenna Height cm	Table Degree degree	Comment
1	*	1698.000	-40.10	4.48	-35.62	-13.00	-22.62	peak		

*:Maximum data x:Over limit !:over margin

File: PG76210(CH777)

Data :#4

Date: 2011/6/23

Time: 下午 02:42:15

20.0 dBm

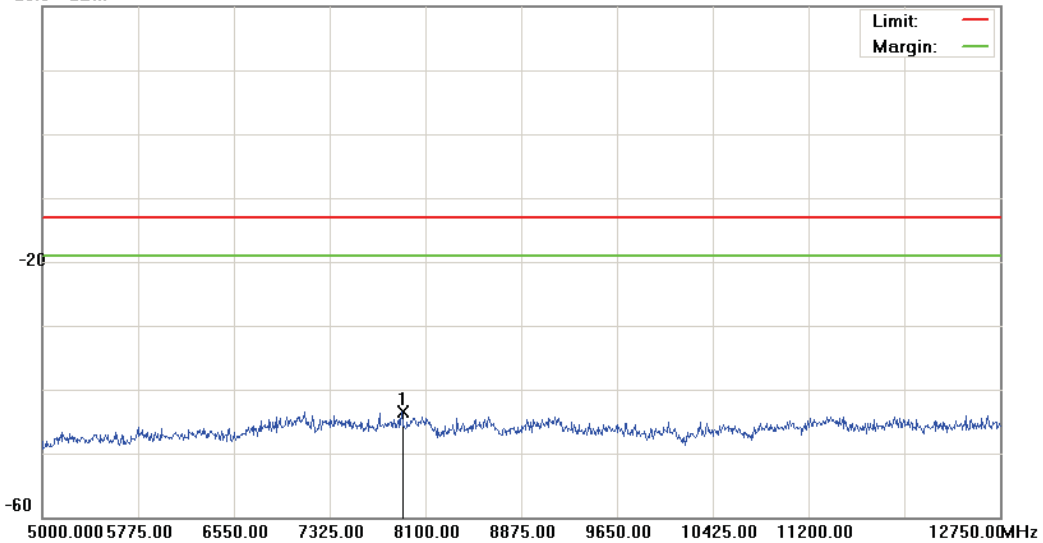

Site: : RF Conducted	Polarization: <i>Conducted po</i>	Temperature: 26 °C
Limit: FCC Part 22 conducted(9k-12.75G)	Power: AC 120V/60Hz	Humidity: 55 %
EUT: Smartphone	Distance:	RBW: 1000 KHz VBW: 1000 KHz
M/N: PG76210		
Mode: 5		
Note: CH777		

No.	Mk.	Freq. MHz	Reading Level dBm	Correct Factor dB	Measure- ment dBm	Limit dBm	Over dB	Antenna Height cm	Table Degree degree	Comment
1	*	7910.125	-48.98	5.41	-43.57	-13.00	-30.57	peak		

*:Maximum data x:Over limit !:over margin

File: PG76210(CH25)

Data :#1

Date: 2011/6/23

Time: 下午 02:01:03

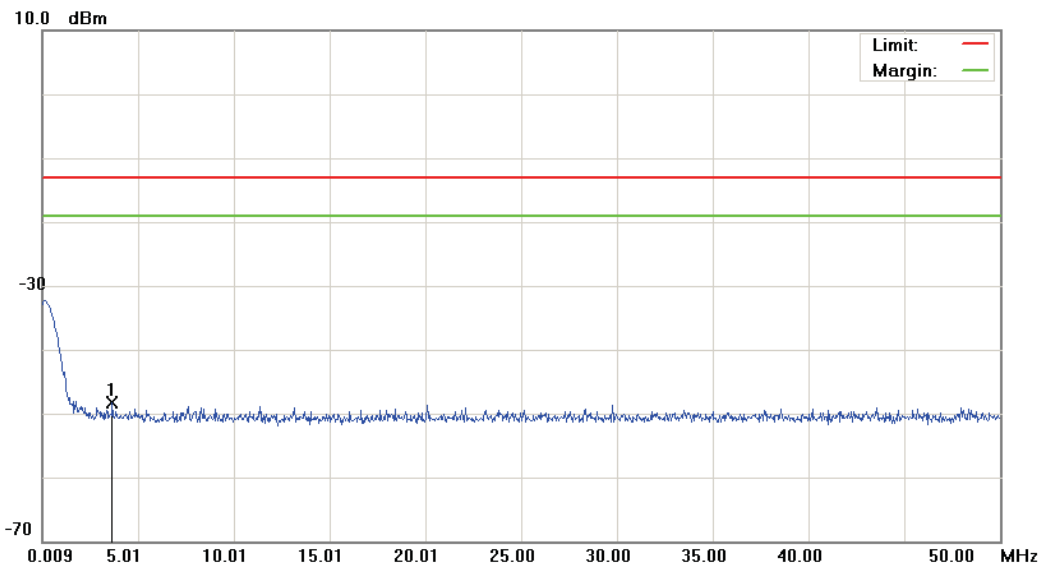

Site: : RF Conducted	Polarization: <i>Conducted po</i>	Temperature: 26 °C
Limit: FCC Part 24 conducted(9k-12.75G)	Power: AC 120V/60Hz	Humidity: 55 %
EUT: Smartphone	Distance:	RBW: 1000 KHz VBW: 1000 KHz
M/N: PG76210		
Mode: 6		
Note: CH25		

No.	Mk.	Freq. MHz	Reading Level dBm	Correct Factor dB	Measure- ment dBm	Limit dBm	Over dB	Antenna Height cm	Table Degree degree	Comment
1	*	3.6583	-61.51	13.16	-48.35	-13.00	-35.35	peak		

*:Maximum data x:Over limit !:over margin

File: PG76210(CH25)

Data :#2

Date: 2011/6/23

Time: 下午 02:01:28

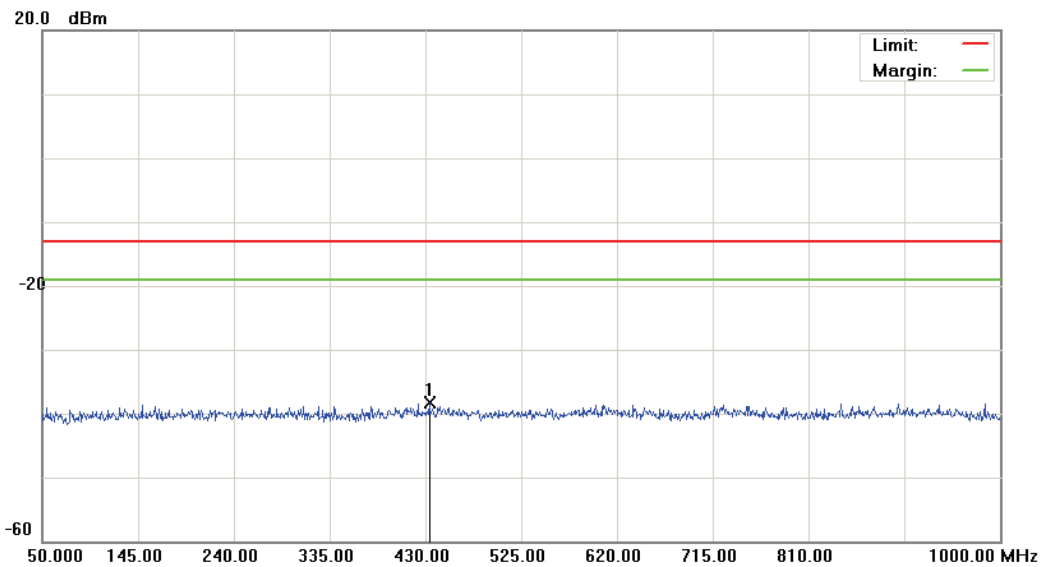

Site: : RF Conducted	Polarization: <i>Conducted po</i>	Temperature: 26 °C
Limit: FCC Part 24 conducted(9k-12.75G)	Power: AC 120V/60Hz	Humidity: 55 %
EUT: Smartphone	Distance:	RBW: 1000 KHz VBW: 1000 KHz
M/N: PG76210		
Mode: 6		
Note: CH25		

No.	Mk.	Freq.	Reading Level	Correct Factor	Measurement	Limit	Over	Antenna Height	Table Degree	
		MHz	dBm	dB	dBm	dBm	dB	cm	degree	Comment
1	*	433.8000	-51.63	13.25	-38.38	-13.00	-25.38	peak		

*:Maximum data x:Over limit !:over margin

File: PG76210(CH25)

Data :#3

Date: 2011/6/23

Time: 下午 02:24:00

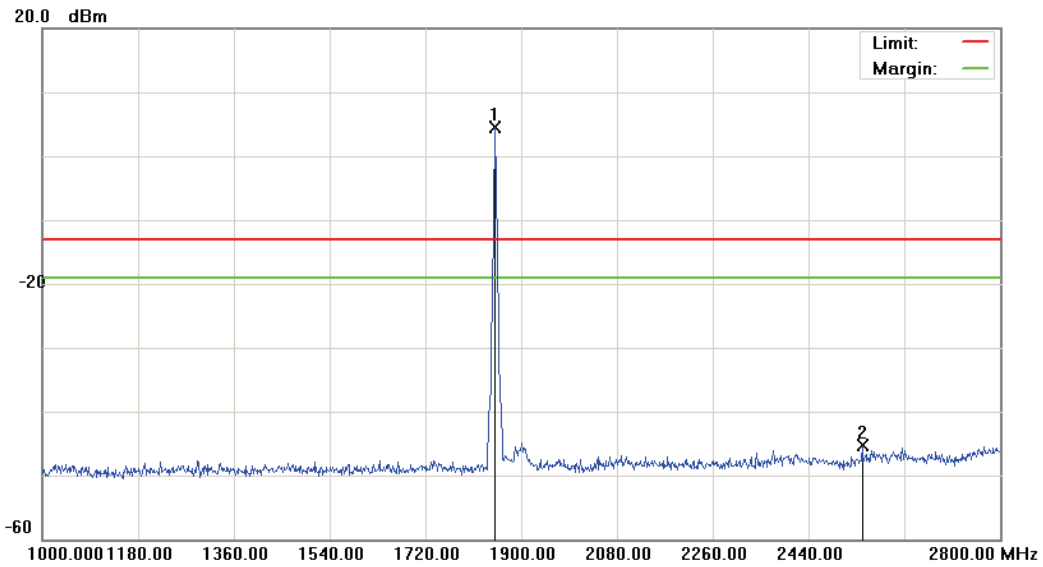

Site: : RF Conducted	Polarization: <i>Conducted po</i>	Temperature: 26 °C
Limit: FCC Part 24 conducted(9k-12.75G)	Power: AC 120V/60Hz	Humidity: 55 %
EUT: Smartphone	Distance:	RBW: 1000 KHz VBW: 1000 KHz
M/N: PG76210		
Mode: 6		
Note: CH25		

No.	Mk.	Freq. MHz	Reading Level dBm	Correct Factor dB	Measure- ment dBm	Limit dBm	Over dB	Detector	Antenna Height cm	Table Degree degree	Comment
1	*	1850.500	0.29	4.26	4.55	-13.00	17.55	peak			TX
2		2541.700	-50.44	5.05	-45.39	-13.00	-32.39	peak			

*:Maximum data x:Over limit !:over margin

File: PG76210(CH25)

Data :#4

Date: 2011/6/23

Time: 下午 02:57:00

20.0 dBm

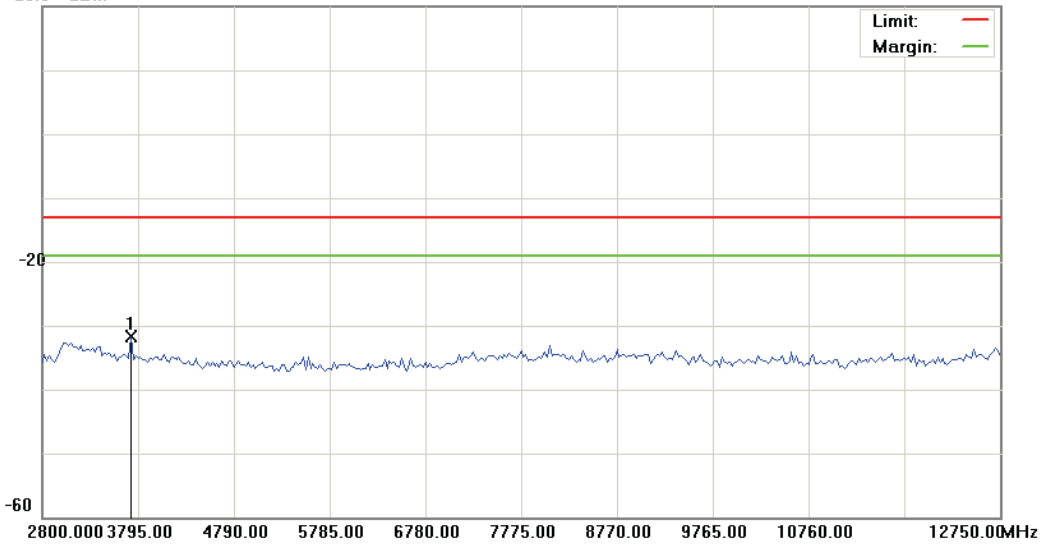

Site: : RF Conducted	Polarization: <i>Conducted po</i>	Temperature: 26 °C
Limit: FCC Part 24 conducted(9k-12.75G)	Power: AC 120V/60Hz	Humidity: 55 %
EUT: Smartphone	Distance:	RBW: 1000 KHz VBW: 1000 KHz
M/N: PG76210		
Mode: 6		
Note: CH25		

No.	Mk.	Freq. MHz	Reading Level dBm	Correct Factor dB	Measure- ment dBm	Limit dBm	Over dB	Detector	Antenna Height cm	Table Degree degree	Comment
1	*	3720.375	-36.54	4.88	-31.66	-13.00	-18.66	peak			

*:Maximum data x:Over limit !:over margin

File: PG76210(CH25)

Data :#5

Date: 2011/6/23

Time: 下午 02:57:25

20.0 dBm

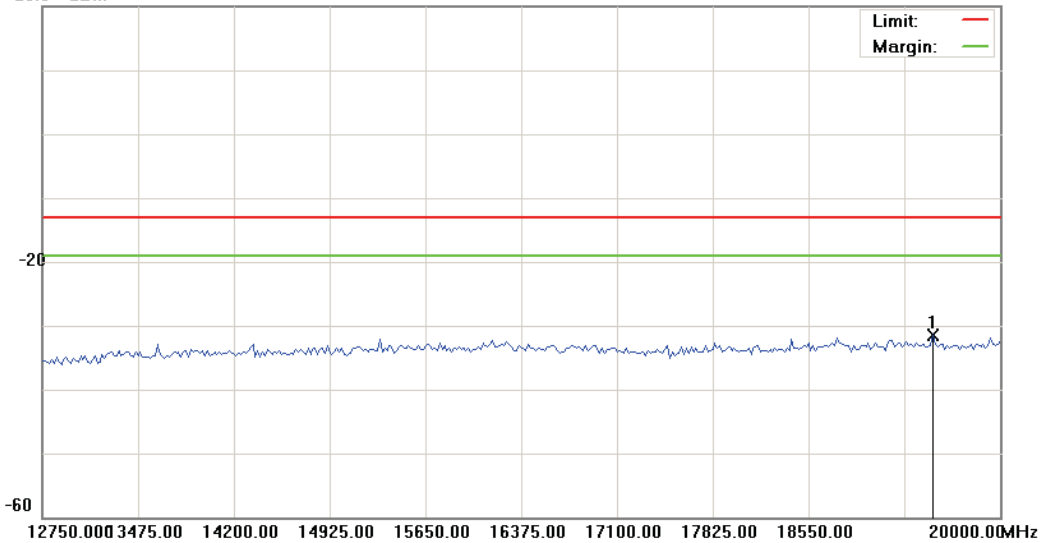

Site: : RF Conducted	Polarization: <i>Conducted po</i>	Temperature: 26 °C
Limit: FCC Part 24 conducted(9k-12.75G)	Power: AC 120V/60Hz	Humidity: 55 %
EUT: Smartphone	Distance:	RBW: 1000 KHz VBW: 1000 KHz
M/N: PG76210		
Mode: 6		
Note: CH25		

No.	Mk.	Freq. MHz	Reading Level dBm	Correct Factor dB	Measure- ment dBm	Limit dBm	Over dB	Antenna Height cm	Table Degree degree	Comment
1	*	19492.500	-38.76	7.30	-31.46	-13.00	-18.46	peak		

*:Maximum data x:Over limit !:over margin

File: PG76210(CH600) Data :#1 Date: 2011/6/23 Time: 下午 02:02:50

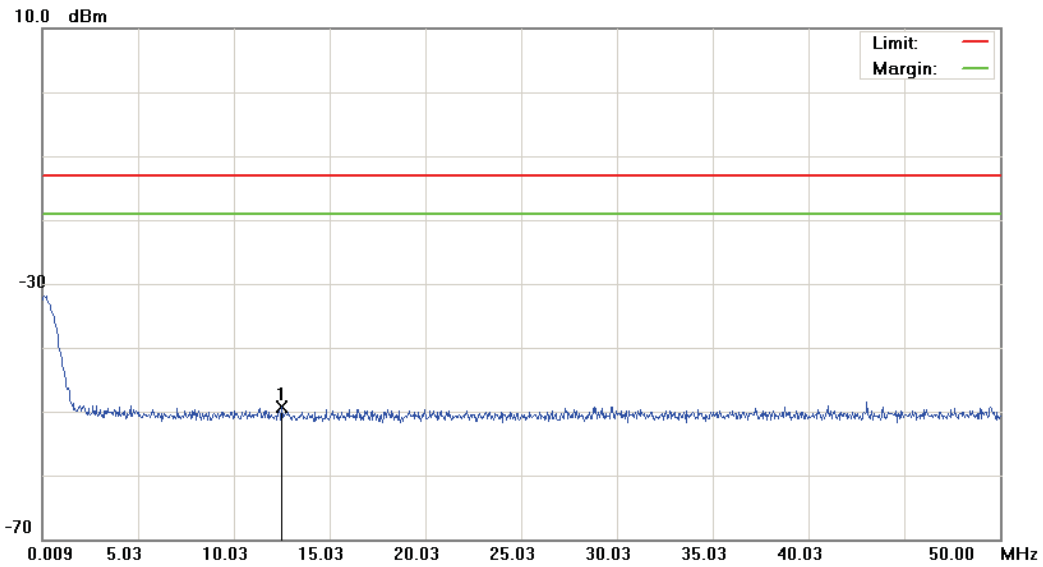

Site: RF Conducted	Polarization: <i>Conducted po</i>	Temperature: 26 °C
Limit: FCC Part 24 conducted(9k-12.75G)	Power: AC 120V/60Hz	Humidity: 55 %
EUT: Smartphone	Distance:	RBW: 1000 KHz VBW: 1000 KHz
M/N: PG76210		
Mode: 6		
Note: CH600		

No.	Mk.	Freq.	Reading Level	Correct Factor	Measurement	Limit	Over	Antenna Height	Table Degree	Detector	Comment
		MHz	dBm	dB	dBm	dBm	dB	cm	degree		
1	*	12.5068	-62.63	13.27	-49.36	-13.00	-36.36			peak	

*:Maximum data x:Over limit !:over margin

File: PG76210(CH600) Data :#2 Date: 2011/6/23 Time: 下午 02:03:14

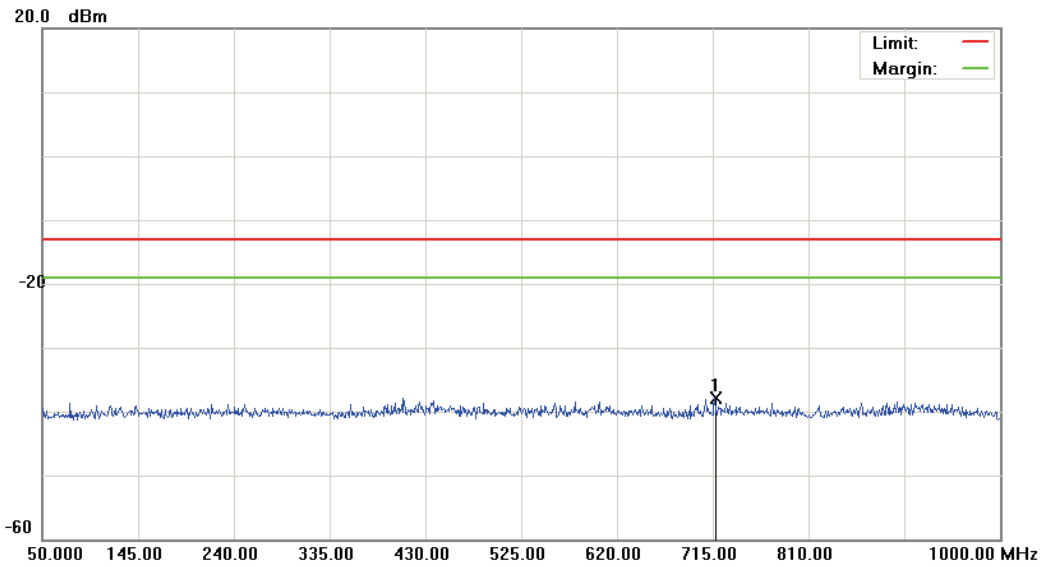

Site: : RF Conducted	Polarization: <i>Conducted po</i>	Temperature: 26 °C
Limit: FCC Part 24 conducted(9k-12.75G)	Power: AC 120V/60Hz	Humidity: 55 %
EUT: Smartphone	Distance:	RBW: 1000 KHz VBW: 1000 KHz
M/N: PG76210		
Mode: 6		
Note: CH600		

No.	Mk.	Freq. MHz	Reading Level dBm	Correct Factor dB	Measure- ment dBm	Limit dBm	Over dB	Antenna Height cm	Table Degree degree	Comment
1	*	717.3750	-50.99	13.14	-37.85	-13.00	-24.85	peak		

*:Maximum data x:Over limit !:over margin

File: PG76210(CH600) Data :#3 Date: 2011/6/23 Time: 下午 02:25:07

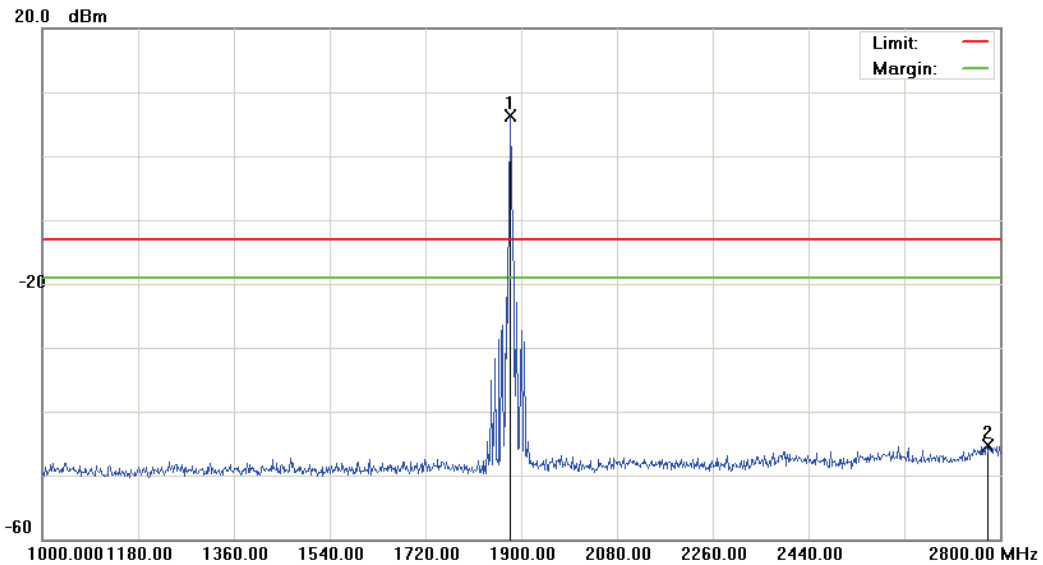

Site: : RF Conducted	Polarization: <i>Conducted po</i>	Temperature: 26 °C
Limit: FCC Part 24 conducted(9k-12.75G)	Power: AC 120V/60Hz	Humidity: 55 %
EUT: Smartphone	Distance:	RBW: 1000 KHz VBW: 1000 KHz
M/N: PG76210		
Mode: 6		
Note: CH600		

No.	Mk.	Freq. MHz	Reading Level dBm	Correct Factor dB	Measure- ment dBm	Limit dBm	Over dB	Antenna Height cm	Table Degree degree	Comment
1	*	1879.300	1.78	4.62	6.40	-13.00	19.40	peak		TX
2		2775.700	-51.12	5.82	-45.30	-13.00	-32.30	peak		

*:Maximum data x:Over limit !:over margin

File: PG76210(CH600) Data :#4 Date: 2011/6/23 Time: 下午 02:58:11

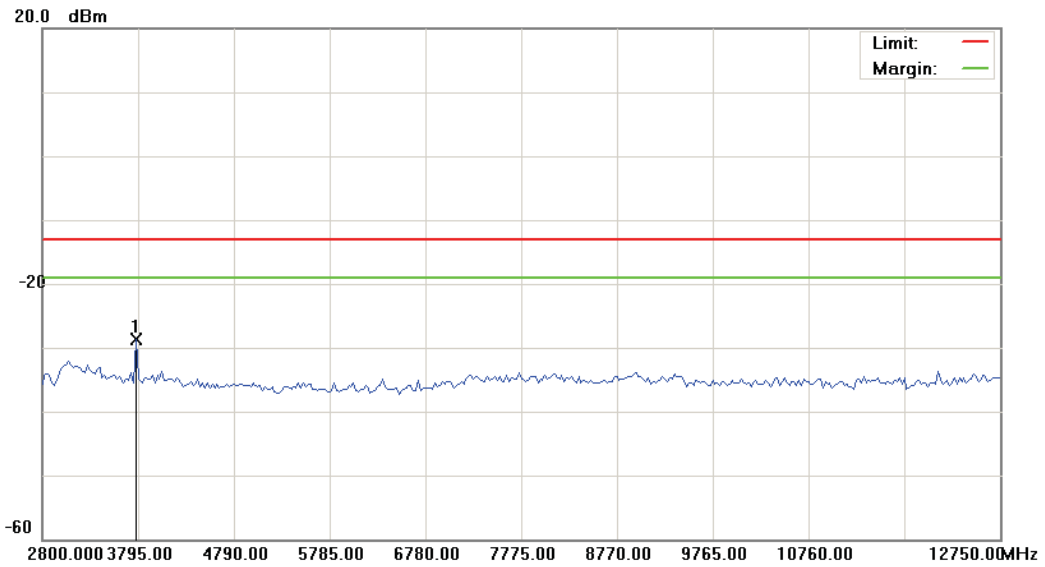

Site: : RF Conducted	Polarization: <i>Conducted po</i>	Temperature: 26 °C
Limit: FCC Part 24 conducted(9k-12.75G)	Power: AC 120V/60Hz	Humidity: 55 %
EUT: Smartphone	Distance:	RBW: 1000 KHz VBW: 1000 KHz
M/N: PG76210		
Mode: 6		
Note: CH600		

No.	Mk.	Freq.	Reading Level	Correct Factor	Measurement	Limit	Over	Antenna Height	Table Degree	
		MHz	dBm	dB	dBm	dBm	dB	cm	degree	Comment
1	*	3770.125	-33.62	4.93	-28.69	-13.00	-15.69			peak

*:Maximum data x:Over limit !:over margin

File: PG76210(CH600) Data :#5 Date: 2011/6/23 Time: 下午 02:58:36

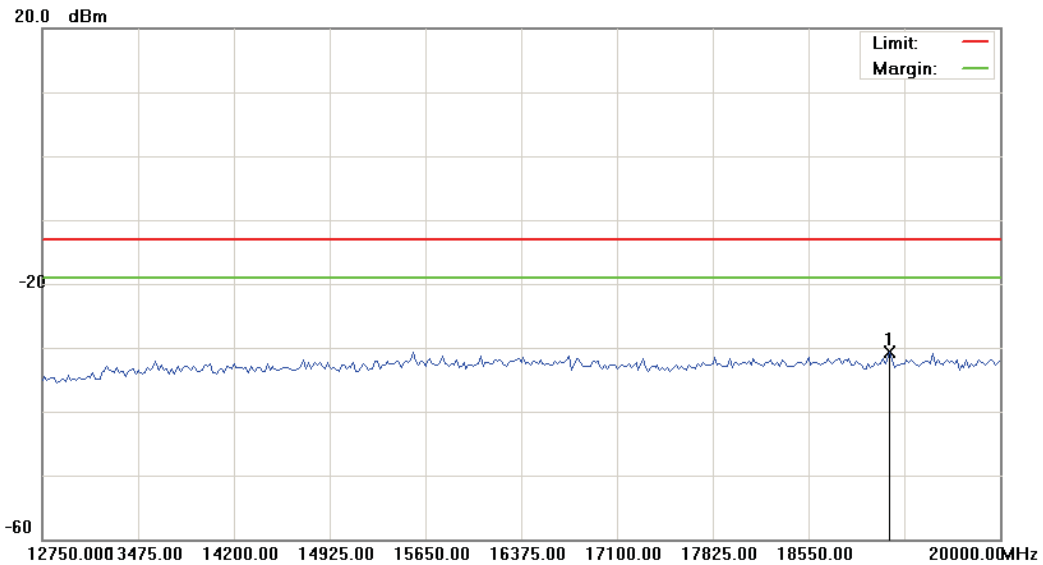

Site: : RF Conducted	Polarization: <i>Conducted po</i>	Temperature: 26 °C
Limit: FCC Part 24 conducted(9k-12.75G)	Power: AC 120V/60Hz	Humidity: 55 %
EUT: Smartphone	Distance:	RBW: 1000 KHz VBW: 1000 KHz
M/N: PG76210		
Mode: 6		
Note: CH600		

No.	Mk.	Freq. MHz	Reading Level dBm	Correct Factor dB	Measure- ment dBm	Limit dBm	Over dB	Antenna Height cm	Table Degree degree	Comment
1	*	19166.250	-37.89	7.20	-30.69	-13.00	-17.69	peak		

*:Maximum data x:Over limit !:over margin

File: PG76210(CH1175)

Data :#1

Date: 2011/6/23

Time: 下午 02:04:43

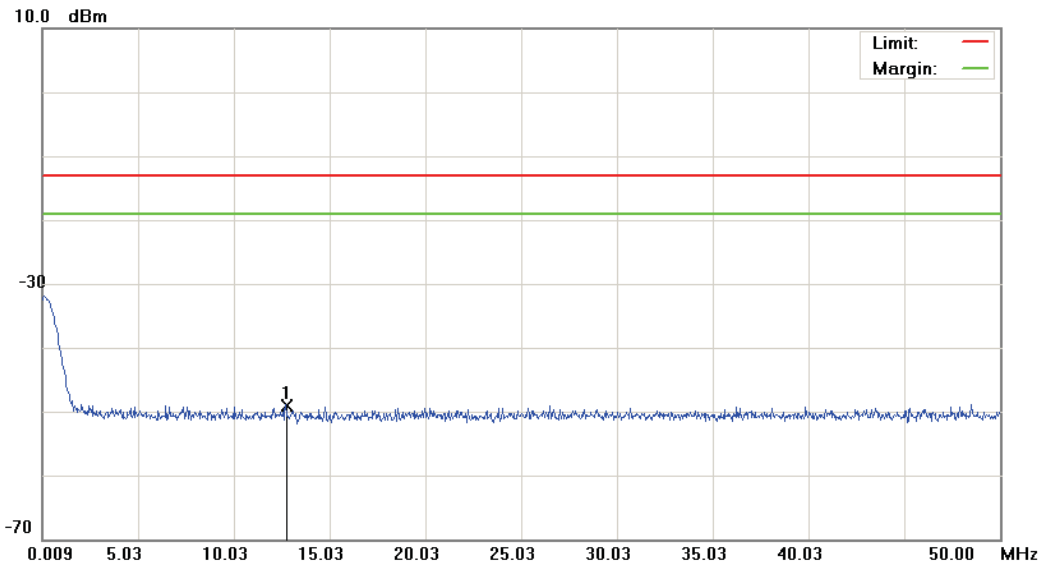

Site: : RF Conducted	Polarization: <i>Conducted po</i>	Temperature: 26 °C
Limit: FCC Part 24 conducted(9k-12.75G)	Power: AC 120V/60Hz	Humidity: 55 %
EUT: Smartphone	Distance:	RBW: 1000 KHz VBW: 1000 KHz
M/N: PG76210		
Mode: 6		
Note: CH1175		

No.	Mk.	Freq.	Reading Level	Correct Factor	Measurement	Limit	Over	Antenna Height	Table Degree	
		MHz	dBm	dB	dBm	dBm	dB	cm	degree	Comment
1	*	12.7317	-62.29	13.29	-49.00	-13.00	-36.00			peak

*:Maximum data x:Over limit !:over margin

File: PG76210(CH1175)

Data :#2

Date: 2011/6/23

Time: 下午 02:05:08

20.0 dBm

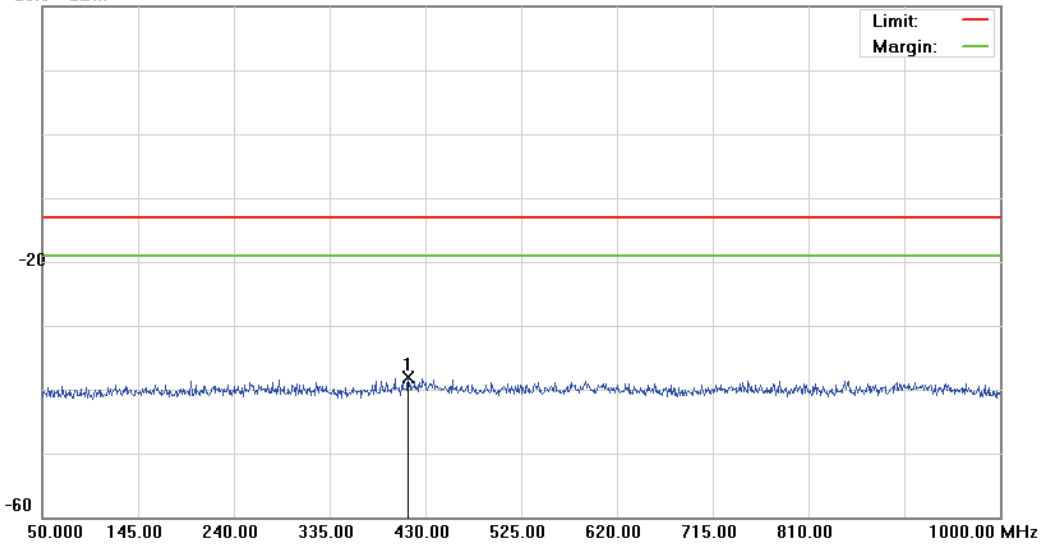

Site: : RF Conducted	Polarization: <i>Conducted po</i>	Temperature: 26 °C
Limit: FCC Part 24 conducted(9k-12.75G)	Power: AC 120V/60Hz	Humidity: 55 %
EUT: Smartphone	Distance:	RBW: 1000 KHz VBW: 1000 KHz
M/N: PG76210		
Mode: 6		
Note: CH1175		

No.	Mk.	Freq. MHz	Reading Level dBm	Correct Factor dB	Measure- ment dBm	Limit dBm	Over dB	Antenna Height cm	Table Degree degree	Comment
1	*	412.9000	-51.31	13.23	-38.08	-13.00	-25.08	peak		

*:Maximum data x:Over limit !:over margin

File: PG76210(CH1175)

Data :#3

Date: 2011/6/23

Time: 下午 02:26:27

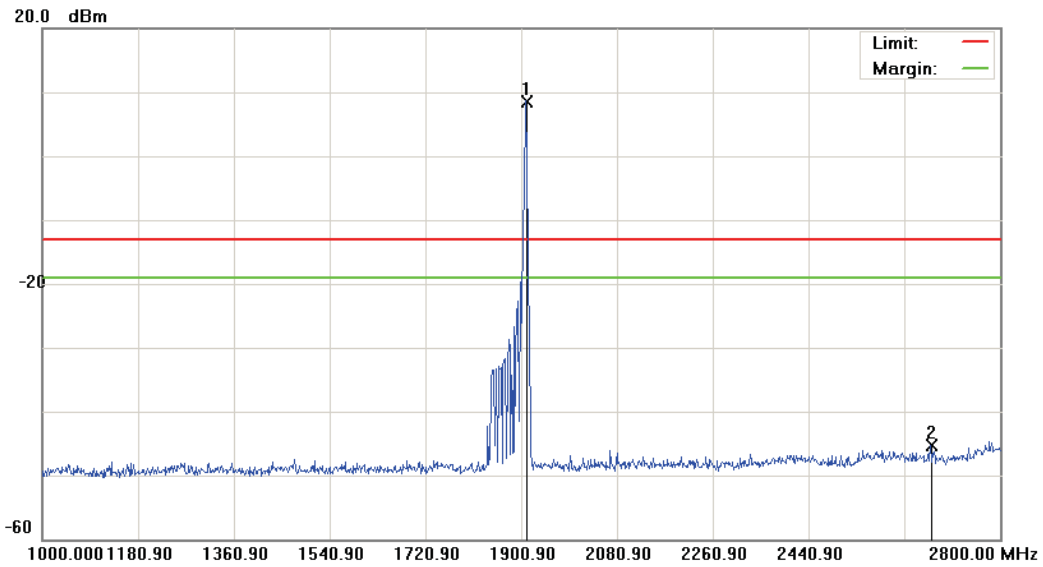

Site: : RF Conducted	Polarization: <i>Conducted po</i>	Temperature: 26 °C
Limit: FCC Part 24 conducted(9k-12.75G)	Power: AC 120V/60Hz	Humidity: 55 %
EUT: Smartphone	Distance:	RBW: 1000 KHz VBW: 1000 KHz
M/N: PG76210		
Mode: 6		
Note: CH1175		

No.	Mk.	Freq. MHz	Reading Level dBm	Correct Factor dB	Measure- ment dBm	Limit dBm	Over dB	Detector	Antenna Height cm	Table Degree degree	Comment
1	*	1909.900	2.89	5.71	8.60	-13.00	21.60	peak			TX
2		2669.500	-50.16	4.89	-45.27	-13.00	-32.27	peak			

*:Maximum data x:Over limit !:over margin

File: PG76210(CH1175)

Data :#4

Date: 2011/6/23

Time: 下午 02:59:17

20.0 dBm

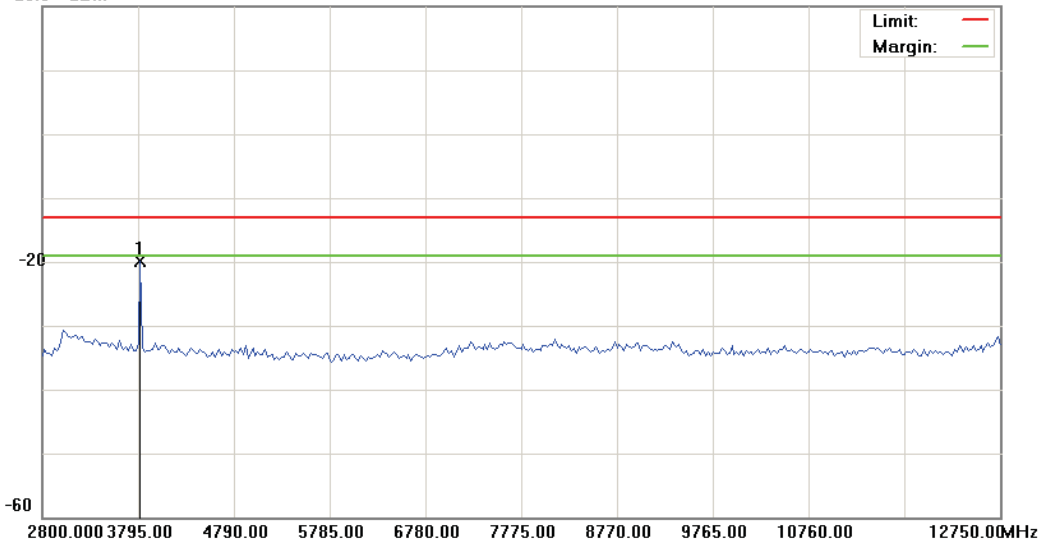

Site: : RF Conducted	Polarization: <i>Conducted po</i>	Temperature: 26 °C
Limit: FCC Part 24 conducted(9k-12.75G)	Power: AC 120V/60Hz	Humidity: 55 %
EUT: Smartphone	Distance:	RBW: 1000 KHz VBW: 1000 KHz
M/N: PG76210		
Mode: 6		
Note: CH1175		

No.	Mk.	Freq. MHz	Reading Level dBm	Correct Factor dB	Measure- ment dBm	Limit dBm	Over dB	Antenna Height cm	Table Degree degree	Comment
1	*	3819.875	-24.81	4.91	-19.90	-13.00	-6.90	peak		

*:Maximum data x:Over limit !:over margin

File: PG76210(CH1175)

Data :#5

Date: 2011/6/23

Time: 下午 02:59:42

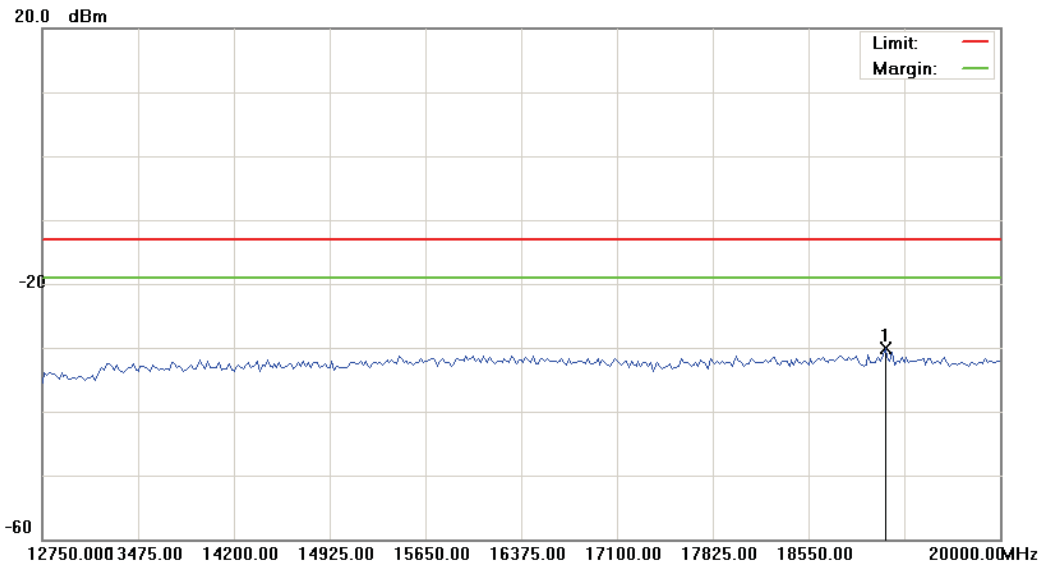

Site: : RF Conducted	Polarization: <i>Conducted po</i>	Temperature: 26 °C
Limit: FCC Part 24 conducted(9k-12.75G)	Power: AC 120V/60Hz	Humidity: 55 %
EUT: Smartphone	Distance:	RBW: 1000 KHz VBW: 1000 KHz
M/N: PG76210		
Mode: 6		
Note: CH1175		

No.	Mk.	Freq. MHz	Reading Level dBm	Correct Factor dB	Measure- ment dBm	Limit dBm	Over dB	Antenna Height cm	Table Degree degree	Comment
1	*	19130.000	-37.34	7.19	-30.15	-13.00	-17.15	peak		

*:Maximum data x:Over limit !:over margin

6 Field Strength of Spurious Radiation Test

6.1. Limit

The power of any emission outside of the authorized operating frequency ranges must be attenuated below the transmitting power (P) by a factor of at least $43 + 10\log(P)$ dB.

It is measured by means of a calibrated spectrum analyzer and scanned from 30 MHz up to a frequency including its 10th harmonic.

6.2. Test Instruments

3 Meter Chamber					
Equipment	Manufacturer	Model No.	Serial No.	Cal. Date	Remark
RF Pre-selector	Agilent	N9039A	MY46520256	01/18/2011	(2)
Spectrum Analyzer	Agilent	E4446A	MY46180578	01/18/2011	(1)
Pre Amplifier	Agilent	8449B	3008A02237	02/23/2011	(1)
Pre Amplifier	Agilent	8447D	2944A10961	02/23/2011	(1)
Broadband Antenna (30MHz~1GHz)	SCHWARZBECK MESS-ELEKTRONIK	VULB9163	9163-270	08/02/2010	(1)
Horn Antenna (1~18GHz)	SCHWARZBECK MESS-ELEKTRONIK	BBHA9120D	9120D-550	06/29/2010	(1)
Horn Antenna (18~40GHz)	SCHWARZBECK MESS-ELEKTRONIK	BBHA9170	9170-320	06/29/2010	(1)
Test Site	ATL	TE01	888001	07/30/2010	(1)

Remark: ⁽¹⁾ Calibration period 1 year. ⁽²⁾ Calibration period 2 years.

NOTE: N.C.R. = No Calibration Request.

6.3. Setup

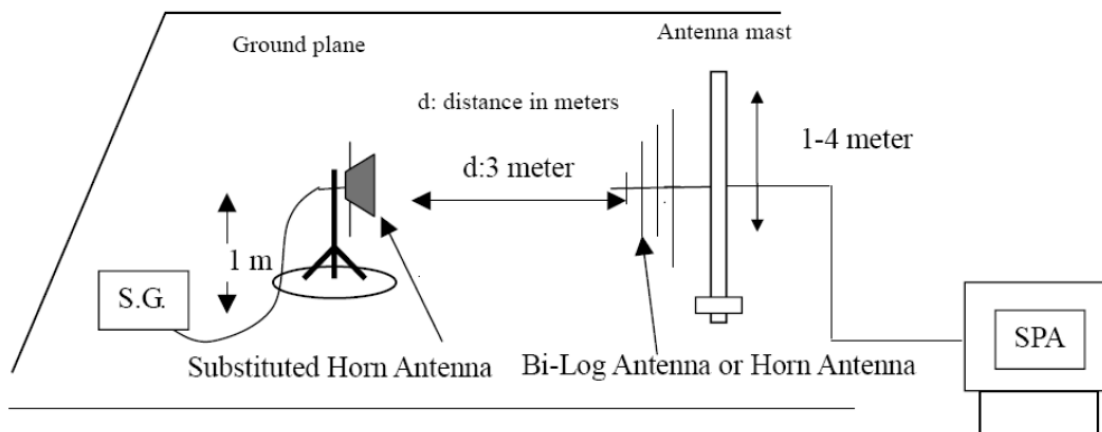

6.4. Test Procedure

The measurement is made according to ANSI/TIA-603-C-2004 as follows:

The equipment under test is placed inside the semi-anechoic chamber on a wooden table at the turntable center. For each spurious frequency, the antenna mast is raised and lowered from 1 to 4 meters and the turntable is rotated 360 degrees to obtain a maximum reading on the spectrum analyzer. This is repeated for both horizontal and vertical polarizations of the receive antenna.

The equipment under test is then replaced with a substitution antenna fed by a signal generator. With the signal generator tuned to a particular spurious frequency, the antenna mast is raised and lowered from 1 to 4 meters to obtain a maximum reading at the spectrum analyzer. The output of the signal generator is then adjusted until a reading identical to that obtained with the actual transmitter is achieved.

The power in dBm of each spurious emission is calculated by correcting the signal generator level for cable loss and gain of the substitution antenna referenced to a dipole. A fully charged battery was used for the supply voltage.

The settings of the receiver were as follows:

Units	dBm
Resolution Bandwidth	1 MHz
Video Bandwidth	Auto
Sweep Time	Auto

The field strength of spurious emission was measured in the following position: EUT stand-up position (Z axis), lie-down position (X, Y axis). The worst emission was found in **lie-down position (X axis)** and the worst case was recorded.

6.5. Uncertainty

The measurement uncertainty is defined as for Field Strength of Spurious Radiation measurement is ± 3.072 dB.

6.6. Test Result

Standard:	FCC Part 22	Test Distance:	3m
Test item:	Radiated Emission	Power:	AC 120V/60Hz
Model:	PG76210	Temp.(°C)/Hum.(%RH):	26(°C)/60%RH
Mode:	Mode 5	Date:	06/24/2011
Frequency:	824.7 MHz	Test By:	Gary Wu

No.	Frequency (MHz)	Reading (dBm)	Correct Factor(dB)	Result (dBm)	Limit (dBm)	Margin (dB)	Remark	Ant.Polar. H / V
1	45.500	-67.53	8.67	-58.86	-13.00	-45.86	peak	H
2	93.500	-67.41	-0.61	-68.02	-13.00	-55.02	peak	H
3	240.500	-63.13	-2.20	-65.33	-13.00	-52.33	peak	H
4	465.500	-78.16	4.93	-73.23	-13.00	-60.23	peak	H
5	583.500	-80.33	7.65	-72.68	-13.00	-59.68	peak	H
6	676.500	-80.58	7.04	-73.54	-13.00	-60.54	peak	H
7	5344.000	-71.79	21.13	-50.66	-13.00	-37.66	peak	H
8	7516.000	-71.16	29.13	-42.03	-13.00	-29.03	peak	H
9	10252.000	-72.96	33.39	-39.57	-13.00	-26.57	peak	H
1	135.500	-73.68	11.39	-62.29	-13.00	-49.29	peak	V
2	172.000	-69.92	2.99	-66.93	-13.00	-53.93	peak	V
3	234.500	-70.90	1.38	-69.52	-13.00	-56.52	peak	V
4	305.500	-75.53	2.25	-73.28	-13.00	-60.28	peak	V
5	440.000	-79.59	1.45	-78.14	-13.00	-65.14	peak	V
6	736.000	-77.49	10.57	-66.92	-13.00	-53.92	peak	V
7	3544.000	-69.49	19.42	-50.07	-13.00	-37.07	peak	V
8	4252.000	-69.66	21.34	-48.32	-13.00	-35.32	peak	V
9	5440.000	-71.55	23.47	-48.08	-13.00	-35.08	peak	V

Standard:	FCC Part 22	Test Distance:	3m
Test item:	Radiated Emission	Power:	AC 120V/60Hz
Model:	PG76210	Temp.(°C)/Hum.(%RH):	26(°C)/60%RH
Mode:	Mode 5	Date:	06/24/2011
Frequency:	837.0 MHz	Test By:	Gary Wu

No.	Frequency (MHz)	Reading (dBm)	Correct Factor(dB)	Result (dBm)	Limit (dBm)	Margin (dB)	Remark	Ant.Polar. H / V
1	36.500	-75.71	8.59	-67.12	-13.00	-54.12	peak	H
2	95.000	-71.01	-0.88	-71.89	-13.00	-58.89	peak	H
3	242.500	-62.33	-2.62	-64.95	-13.00	-51.95	peak	H
4	312.500	-68.85	-1.46	-70.31	-13.00	-57.31	peak	H
5	472.000	-77.54	5.28	-72.26	-13.00	-59.26	peak	H
6	718.500	-80.25	7.45	-72.80	-13.00	-59.80	peak	H
7	6496.000	-73.62	25.92	-47.70	-13.00	-34.70	peak	H
8	8116.000	-72.29	29.55	-42.74	-13.00	-29.74	peak	H
9	10720.000	-72.64	35.22	-37.42	-13.00	-24.42	peak	H
1	131.500	-78.21	13.56	-64.65	-13.00	-51.65	peak	V
2	162.000	-77.12	10.79	-66.33	-13.00	-53.33	peak	V
3	192.000	-69.75	2.63	-67.12	-13.00	-54.12	peak	V
4	237.500	-69.76	0.83	-68.93	-13.00	-55.93	peak	V
5	303.500	-75.10	2.42	-72.68	-13.00	-59.68	peak	V
6	597.500	-77.81	7.26	-70.55	-13.00	-57.55	peak	V
7	5332.000	-71.98	23.41	-48.57	-13.00	-35.57	peak	V
8	8320.000	-71.78	26.18	-45.60	-13.00	-32.60	peak	V
9	9952.000	-73.16	30.39	-42.77	-13.00	-29.77	peak	V

Standard:	FCC Part 22	Test Distance:	3m
Test item:	Radiated Emission	Power:	AC 120V/60Hz
Model:	PG76210	Temp.(°C)/Hum.(%RH):	26(°C)/60%RH
Mode:	Mode 5	Date:	06/24/2011
Frequency:	848.3 MHz	Test By:	Gary Wu

No.	Frequency (MHz)	Reading (dBm)	Correct Factor(dB)	Result (dBm)	Limit (dBm)	Margin (dB)	Remark	Ant.Polar. H / V
1	37.000	-76.93	8.74	-68.19	-13.00	-55.19	peak	H
2	94.000	-68.40	-0.71	-69.11	-13.00	-56.11	peak	H
3	247.000	-61.51	-3.57	-65.08	-13.00	-52.08	peak	H
4	377.500	-74.17	0.69	-73.48	-13.00	-60.48	peak	H
5	465.500	-77.33	4.93	-72.40	-13.00	-59.40	peak	H
6	561.500	-80.46	7.80	-72.66	-13.00	-59.66	peak	H
7	3976.000	-67.73	16.39	-51.34	-13.00	-38.34	peak	H
8	6796.000	-71.42	26.97	-44.45	-13.00	-31.45	peak	H
9	8260.000	-71.35	29.22	-42.13	-13.00	-29.13	peak	H
1	130.500	-77.13	14.09	-63.04	-13.00	-50.04	peak	V
2	165.000	-74.37	7.96	-66.41	-13.00	-53.41	peak	V
3	236.500	-69.82	1.03	-68.79	-13.00	-55.79	peak	V
4	306.000	-74.48	2.22	-72.26	-13.00	-59.26	peak	V
5	604.500	-78.22	7.78	-70.44	-13.00	-57.44	peak	V
6	665.500	-78.29	9.44	-68.85	-13.00	-55.85	peak	V
7	4012.000	-68.65	20.63	-48.02	-13.00	-35.02	peak	V
8	7552.000	-71.75	26.42	-45.33	-13.00	-32.33	peak	V
9	9568.000	-72.40	28.69	-43.71	-13.00	-30.71	peak	V

Standard:	FCC Part 24	Test Distance:	3m
Test item:	Radiated Emission	Power:	AC 120V/60Hz
Model:	PG76210	Temp.(°C)/Hum.(%RH):	26(°C)/60%RH
Mode:	Mode 6	Date:	06/24/2011
Frequency:	1851.25 MHz	Test By:	Gary Wu

No.	Frequency (MHz)	Reading (dBm)	Correct Factor(dB)	Result (dBm)	Limit (dBm)	Margin (dB)	Remark	Ant.Polar. H / V
1	91.000	-65.87	-0.16	-66.03	-13.00	-53.03	peak	H
2	258.500	-65.90	-4.32	-70.22	-13.00	-57.22	peak	H
3	496.500	-81.13	6.75	-74.38	-13.00	-61.38	peak	H
4	619.000	-77.42	7.72	-69.70	-13.00	-56.70	peak	H
5	764.500	-81.31	9.34	-71.97	-13.00	-58.97	peak	H
6	855.000	-80.66	12.79	-67.87	-13.00	-54.87	peak	H
7	3700.000	-65.99	15.75	-50.24	-13.00	-37.24	peak	H
8	7876.000	-71.90	29.64	-42.26	-13.00	-29.26	peak	H
9	10912.000	-73.44	36.07	-37.37	-13.00	-24.37	peak	H
1	132.500	-76.37	13.01	-63.36	-13.00	-50.36	peak	V
2	164.000	-73.02	8.89	-64.13	-13.00	-51.13	peak	V
3	244.000	-67.38	-0.14	-67.52	-13.00	-54.52	peak	V
4	307.000	-75.41	2.13	-73.28	-13.00	-60.28	peak	V
5	535.500	-79.00	4.00	-75.00	-13.00	-62.00	peak	V
6	721.500	-81.23	10.83	-70.40	-13.00	-57.40	peak	V
7	3700.000	-55.19	19.81	-35.38	-13.00	-22.38	peak	V
8	6532.000	-71.19	24.75	-46.44	-13.00	-33.44	peak	V
9	9928.000	-73.00	30.29	-42.71	-13.00	-29.71	peak	V

Standard:	FCC Part 24	Test Distance:	3m
Test item:	Radiated Emission	Power:	AC 120V/60Hz
Model:	PG76210	Temp.(°C)/Hum.(%RH):	26(°C)/60%RH
Mode:	Mode 6	Date:	06/24/2011
Frequency:	1880.0 MHz	Test By:	Gary Wu

No.	Frequency (MHz)	Reading (dBm)	Correct Factor(dB)	Result (dBm)	Limit (dBm)	Margin (dB)	Remark	Ant.Polar. H / V
1	90.500	-66.33	-0.07	-66.40	-13.00	-53.40	peak	H
2	257.500	-65.82	-4.31	-70.13	-13.00	-57.13	peak	H
3	275.500	-67.69	-4.34	-72.03	-13.00	-59.03	peak	H
4	317.500	-72.89	-1.10	-73.99	-13.00	-60.99	peak	H
5	508.000	-79.83	7.24	-72.59	-13.00	-59.59	peak	H
6	628.000	-77.38	7.36	-70.02	-13.00	-57.02	peak	H
7	3760.000	-61.12	15.89	-45.23	-13.00	-32.23	peak	H
8	7876.000	-71.57	29.64	-41.93	-13.00	-28.93	peak	H
9	10480.000	-72.70	34.20	-38.50	-13.00	-25.50	peak	H
1	135.000	-74.51	11.66	-62.85	-13.00	-49.85	peak	V
2	173.000	-68.37	2.89	-65.48	-13.00	-52.48	peak	V
3	195.000	-73.43	5.46	-67.97	-13.00	-54.97	peak	V
4	247.000	-66.54	-0.53	-67.07	-13.00	-54.07	peak	V
5	612.500	-77.11	8.36	-68.75	-13.00	-55.75	peak	V
6	699.000	-79.46	10.17	-69.29	-13.00	-56.29	peak	V
7	3760.000	-53.32	19.98	-33.34	-13.00	-20.34	peak	V
8	6916.000	-71.81	25.44	-46.37	-13.00	-33.37	peak	V
9	9724.000	-72.41	29.39	-43.02	-13.00	-30.02	peak	V

Standard:	FCC Part 24	Test Distance:	3m
Test item:	Radiated Emission	Power:	AC 120V/60Hz
Model:	PG76210	Temp.(°C)/Hum.(%RH):	26(°C)/60%RH
Mode:	Mode 6	Date:	06/24/2011
Frequency:	1908.75 MHz	Test By:	Gary Wu

No.	Frequency (MHz)	Reading (dBm)	Correct Factor(dB)	Result (dBm)	Limit (dBm)	Margin (dB)	Remark	Ant.Polar. H / V
1	92.000	-70.38	-0.34	-70.72	-13.00	-57.72	peak	H
2	255.500	-66.07	-4.28	-70.35	-13.00	-57.35	peak	H
3	487.000	-80.68	6.16	-74.52	-13.00	-61.52	peak	H
4	552.500	-80.23	7.97	-72.26	-13.00	-59.26	peak	H
5	628.000	-78.57	7.36	-71.21	-13.00	-58.21	peak	H
6	937.000	-81.49	14.84	-66.65	-13.00	-53.65	peak	H
7	3820.000	-55.68	16.03	-39.65	-13.00	-26.65	peak	H
8	7408.000	-70.83	28.83	-42.00	-13.00	-29.00	peak	H
9	10996.000	-73.92	36.43	-37.49	-13.00	-24.49	peak	H
1	123.500	-71.63	7.92	-63.71	-13.00	-50.71	peak	V
2	160.500	-77.95	12.20	-65.75	-13.00	-52.75	peak	V
3	236.000	-68.21	1.10	-67.11	-13.00	-54.11	peak	V
4	300.500	-76.22	2.67	-73.55	-13.00	-60.55	peak	V
5	618.500	-78.45	8.77	-69.68	-13.00	-56.68	peak	V
6	783.500	-80.28	11.38	-68.90	-13.00	-55.90	peak	V
7	3820.000	-46.73	20.13	-26.60	-13.00	-13.60	peak	V
8	7768.000	-70.87	26.48	-44.39	-13.00	-31.39	peak	V
9	10456.000	-73.15	33.18	-39.97	-13.00	-26.97	peak	V

7 Frequency Stability (Temperature Variation) Test

7.1. Limit

The frequency stability shall be measured by variation of ambient temperature and variation of primary supply voltage to ensure that the fundamental emission stays within the authorized frequency block. The frequency stability of the transmitter shall be maintained within $\pm 0.00025\%$ ($\pm 2.5\text{ppm}$) of the center frequency.

7.2. Test Instruments

Describe	Manufacturer	Model No.	Serial No.	Cal. Date	Remark
Universal Radio Communication Tester	ROHDE & SCHWARZ	CMU200	109369	08/10/2010	(2)
Temperature & Humidity Chamber	TAICHY	MHU-225LA	980729	08/26/2010	(2)
Test Site	ATL	TE02	TE02	N.C.R.	-----

Remark: ⁽¹⁾ Calibration period 1 year. ⁽²⁾ Calibration period 2 years.

NOTE: N.C.R. = No Calibration Request.

7.3. Setup

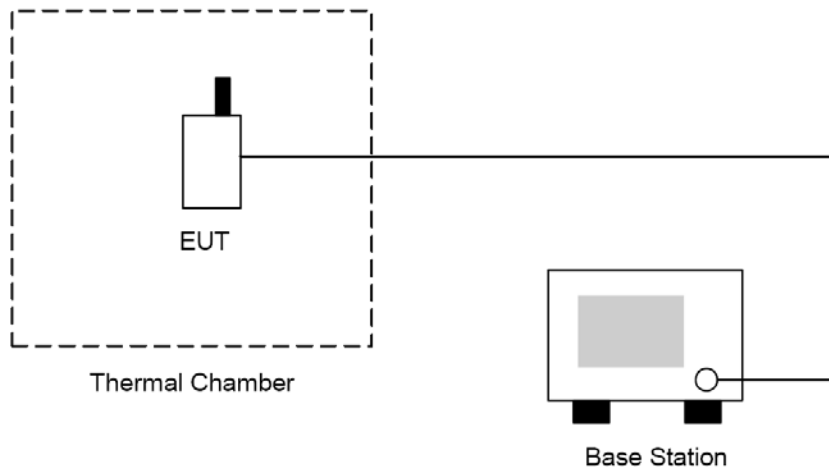

7.4. Test Procedure

The measurement is made according to FCC rules part 22 and 24:

1. The EUT and test equipment were set up as shown on the following section.
2. With all power removed, the temperature was decreased to -30°C and permitted to stabilize for three hours. Power was applied and the maximum change in frequency was note within one minute.
3. With power OFF, the temperature was raised in 10°C steps. The sample was permitted to stabilize at each step for at least one-half hour. Power was applied and the maximum frequency change was noted within one minute.
4. The temperature tests were performed for the worst case.
5. Test data was recorded.

7.5. Uncertainty

The measurement uncertainty is defined as for Frequency Stability (Temperature Variation) measurement is $\pm 10\text{Hz}$.

7.6. Test Result

Model Number	PG76210			
Test Item	Frequency Stability (Temperature Variation)			
Test Mode	Mode 5			
Date of Test	06/23/2011		Test Site	TE02
Temperature (°C)	Deviation (Hz)	Deviation (ppm)	Limit (ppm)	Result
-30	7	0.008	±2.5	Pass
-20	8	0.010	±2.5	Pass
-10	-4	-0.005	±2.5	Pass
0	-3	-0.004	±2.5	Pass
10	-3	-0.004	±2.5	Pass
20	-4	-0.005	±2.5	Pass
30	-6	-0.007	±2.5	Pass
40	7	0.008	±2.5	Pass
50	9	0.011	±2.5	Pass

Model Number	PG76210			
Test Item	Frequency Stability (Temperature Variation)			
Test Mode	Mode 6			
Date of Test	06/23/2011		Test Site	TE02
Temperature (°C)	Deviation (Hz)	Deviation (ppm)	Limit (ppm)	Result
-30	37	0.020	±2.5	Pass
-20	-30	-0.016	±2.5	Pass
-10	20	0.011	±2.5	Pass
0	24	0.013	±2.5	Pass
10	-18	-0.010	±2.5	Pass
20	24	0.013	±2.5	Pass
30	22	0.012	±2.5	Pass
40	-35	-0.019	±2.5	Pass
50	-47	-0.025	±2.5	Pass

8 Frequency Stability (Voltage Variation) Test

8.1. Limit

The frequency stability shall be measured by variation of ambient temperature and variation of primary supply voltage to ensure that the fundamental emission stays within the authorized frequency block. The frequency stability of the transmitter shall be maintained within $\pm 0.00025\%$ ($\pm 2.5\text{ppm}$) of the center frequency.

8.2. Test Instruments

Describe	Manufacturer	Model No.	Serial No.	Cal. Date	Remark
Universal Radio Communication Tester	ROHDE & SCHWARZ	CMU200	109369	08/10/2010	(2)
Temperature & Humidity Chamber	TAICHY	MHU-225LA	980729	08/26/2010	(2)
Test Site	ATL	TE02	TE02	N.C.R.	-----

Remark: ⁽¹⁾ Calibration period 1 year. ⁽²⁾ Calibration period 2 years.

NOTE: N.C.R. = No Calibration Request.

8.3. Setup

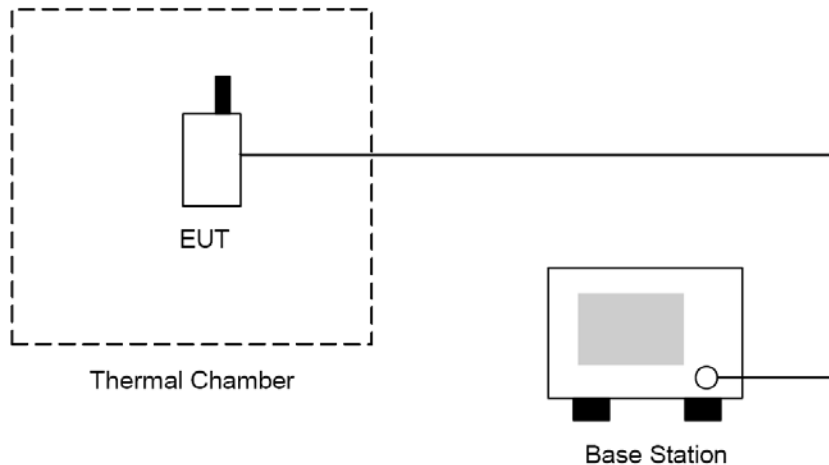

8.4. Test Procedure

1. The EUT was placed in a temperature chamber at $25 \pm 5 \text{ }^\circ\text{C}$ and connected as the following section.
2. The power supply voltage to the EUT was varied from BEP to 115% of the nominal value measured at the input to the EUT.
3. The variation in frequency was measured for the worst case.

8.5. Uncertainty

The measurement uncertainty is defined as for Frequency Stability (Voltage Variation) measurement is $\pm 10\text{Hz}$.

8.6. Test Result

Model Number	PG76210				
Test Item	Frequency Stability (Voltage Variation)				
Test Mode	Mode 5				
Date of Test	06/23/2011		Test Site	TE02	
Level	Voltage [V]	Deviation [Hz]	Deviation [ppm]	Limit [ppm]	Result
Battery full point	4.07	10	0.012	± 2.5	Pass
Normal	3.70	8	0.010	± 2.5	Pass
Battery cut-off point	3.33	10	0.012	± 2.5	Pass

Model Number	PG76210				
Test Item	Frequency Stability (Voltage Variation)				
Test Mode	Mode 6				
Date of Test	06/23/2011		Test Site	TE02	
Level	Voltage [V]	Deviation [Hz]	Deviation [ppm]	Limit [ppm]	Result
Battery full point	4.07	16	0.009	± 2.5	Pass
Normal	3.70	15	0.008	± 2.5	Pass
Battery cut-off point	3.33	18	0.010	± 2.5	Pass

9 AC Power Conducted Emissions Test

9.1. Limit

Frequency range (MHz)	Limits (dBuV)	
	Quasi-peak	Average
0.15 to 0.50	66 to 56	56 to 46
0.50 to 5.0	56	46
5.0 to 30	60	50

9.2. Test Instruments

Describe	Manufacturer	Model No.	Serial No.	Cal. Date	Remark
Test Receiver	R&S	ESCI	100367	07/01/2009	(1)
LISN	R&S	ENV216	101040	03/04/2011	(1)
LISN	R&S	ENV216	101041	03/04/2011	(1)
Test Site	ATL	TE02	TE02	N.C.R.	-----

Remark: ⁽¹⁾ Calibration period 1 year. ⁽²⁾ Calibration period 2 years.

NOTE: N.C.R. = No Calibration Request.

9.3. Setup

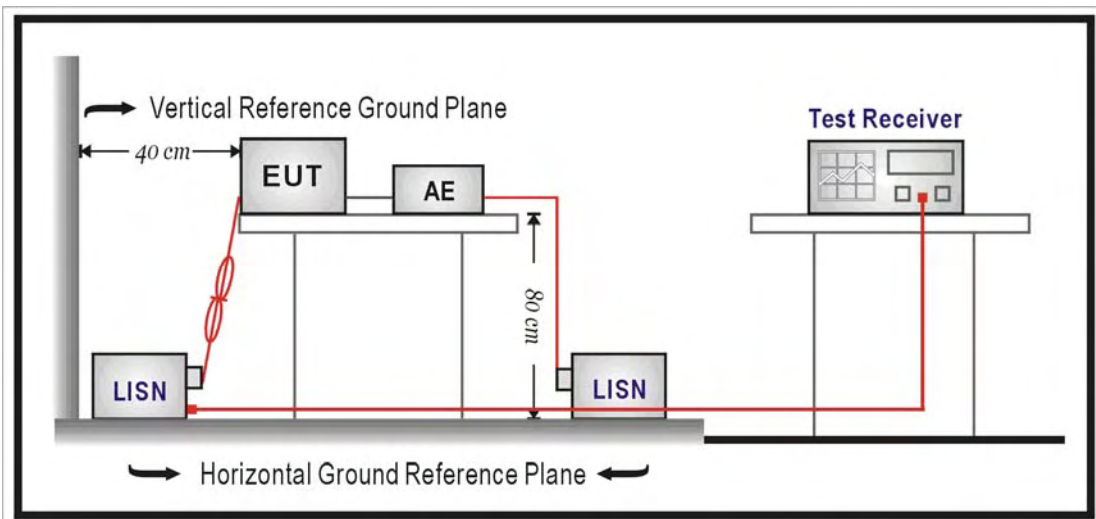

9.4. Test Procedure

The measurement is made according to FCC rules 15.207:

The power line conducted emission measurements were performed in a shielded enclosure. The EUT was assembled on a wooden table which is 80 centimeters high, was placed 40 centimeters from the back wall and at least 1 meter from the sidewall.

Power was fed to the EUT from the public utility power grid through a line filter and EMCO Model 3162/2 SH Line Impedance Stabilization Networks (LISN). The LISN housing, measuring instrumentation case, ground plane, etc., were electrically bonded together at the same RF potential. The Spectrum analyzer was connected to the AC line through an isolation transformer. The 50-ohm output of the LISN was connected to the spectrum analyzer directly. Conducted emission levels were in the CISPR quasi-peak detection mode. The analyzer's 6 dB bandwidth was set to 9 KHz. No post-detector video filter was used.

The spectrum was scanned from 150 KHz to 30 MHz. The physical arrangement of the test system and associated cabling was varied (within the scope of arrangements likely to be encountered in actual use) to determine the effect on the unit's emanations in amplitude and frequency. All spurious emission frequencies were observed. The highest emission amplitudes relative to the appropriate limit were measured and have been recorded in section 10.6.

9.5. Uncertainty

The measurement uncertainty is defined as for AC power conducted emission measurement is ± 2.24 dB.

9.6. Test Result

Standard:	FCC Part 22	Line:	L1
Test item:	Conducted Emission	Power:	AC 120V/60Hz
Model:	PG76210	Temp.(°C)/Hum.(%RH):	26(°C)/60%RH
Mode:	Mode 5	Date:	06/29/2011
		Test By:	Gary Wu
Description:			

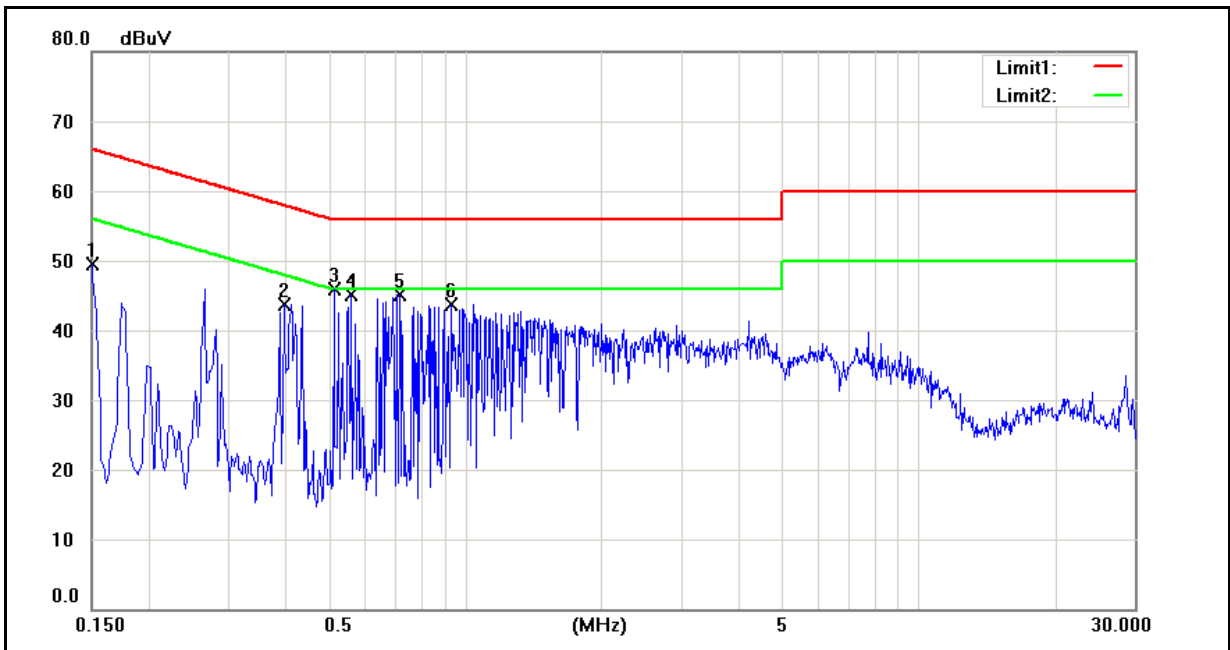

No.	Frequency (MHz)	QP reading (dBuV)	AVG reading (dBuV)	Correction factor (dB)	QP result (dBuV)	AVG result (dBuV)	QP limit (dBuV)	AVG limit (dBuV)	QP margin (dB)	AVG margin (dB)	Remark
1	0.1500	35.60	14.56	10.07	45.67	24.63	66.00	56.00	-20.33	-31.37	Pass
2	0.3980	30.31	13.97	9.97	40.28	23.94	57.90	47.90	-17.62	-23.96	Pass
3	0.5140	31.07	8.28	9.92	40.99	18.20	56.00	46.00	-15.01	-27.80	Pass
4	0.5620	30.93	8.99	9.90	40.83	18.89	56.00	46.00	-15.17	-27.11	Pass
5	0.7180	30.20	11.05	9.85	40.05	20.90	56.00	46.00	-15.95	-25.10	Pass
6	0.9380	28.93	10.06	9.76	38.69	19.82	56.00	46.00	-17.31	-26.18	Pass
7	0.9580	31.14	12.45	9.75	40.89	22.20	56.00	46.00	-15.11	-23.80	Pass

Standard:	FCC Part 22	Line:	N
Test item:	Conducted Emission	Power:	AC 120V/60Hz
Model:	PG76210	Temp.(°C)/Hum.(%RH):	26(°C)/60%RH
Mode:	Mode 5	Date:	06/29/2011
		Test By:	Gary Wu
Description:			

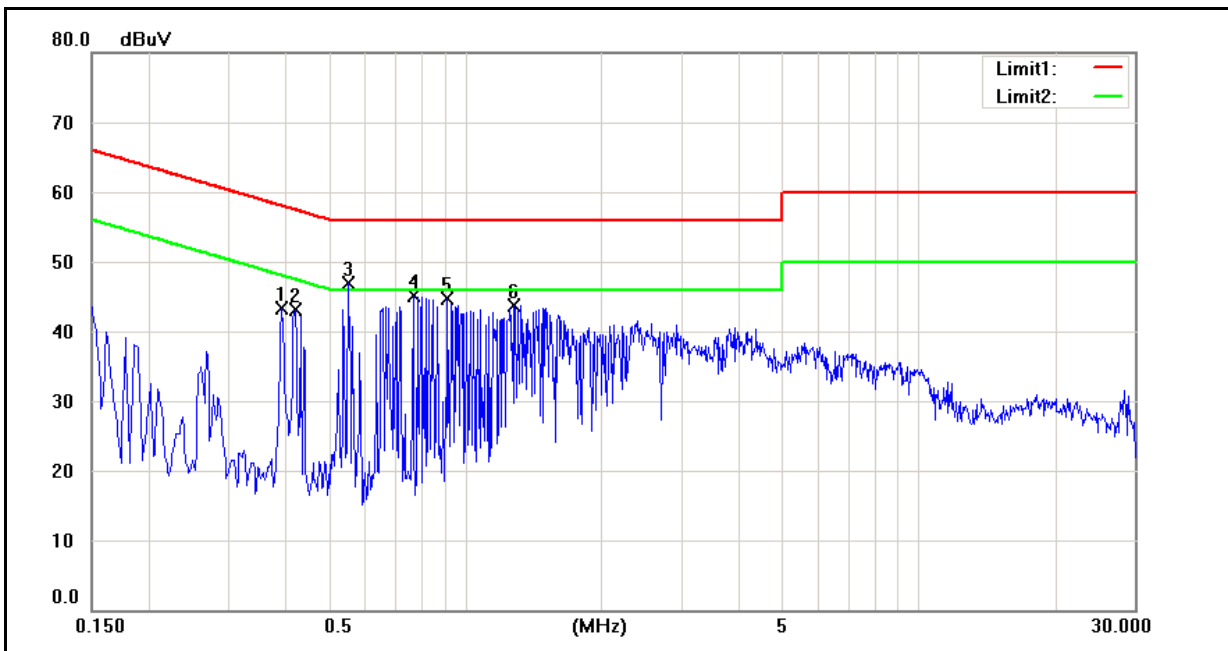

No.	Frequency (MHz)	QP reading (dBuV)	AVG reading (dBuV)	Correction factor (dB)	QP result (dBuV)	AVG result (dBuV)	QP limit (dBuV)	AVG limit (dBuV)	QP margin (dB)	AVG margin (dB)	Remark
1	0.3940	29.23	9.91	10.05	39.28	19.96	57.98	47.98	-18.70	-28.02	Pass
2	0.4220	29.45	9.26	10.04	39.49	19.30	57.41	47.41	-17.92	-28.11	Pass
3	0.5540	32.01	8.61	9.99	42.00	18.60	56.00	46.00	-14.00	-27.40	Pass
4	0.7700	29.35	7.06	9.90	39.25	16.96	56.00	46.00	-16.75	-29.04	Pass
5	0.9180	29.26	7.36	9.83	39.09	17.19	56.00	46.00	-16.91	-28.81	Pass
6	1.2820	28.69	10.18	9.77	38.46	19.95	56.00	46.00	-17.54	-26.05	Pass

Standard:	FCC Part 24	Line:	L1
Test item:	Conducted Emission	Power:	AC 120V/60Hz
Model:	PG76210	Temp.(°C)/Hum.(%RH):	26(°C)/60%RH
Mode:	Mode 6	Date:	06/29/2011
		Test By:	Gary Wu
Description:			

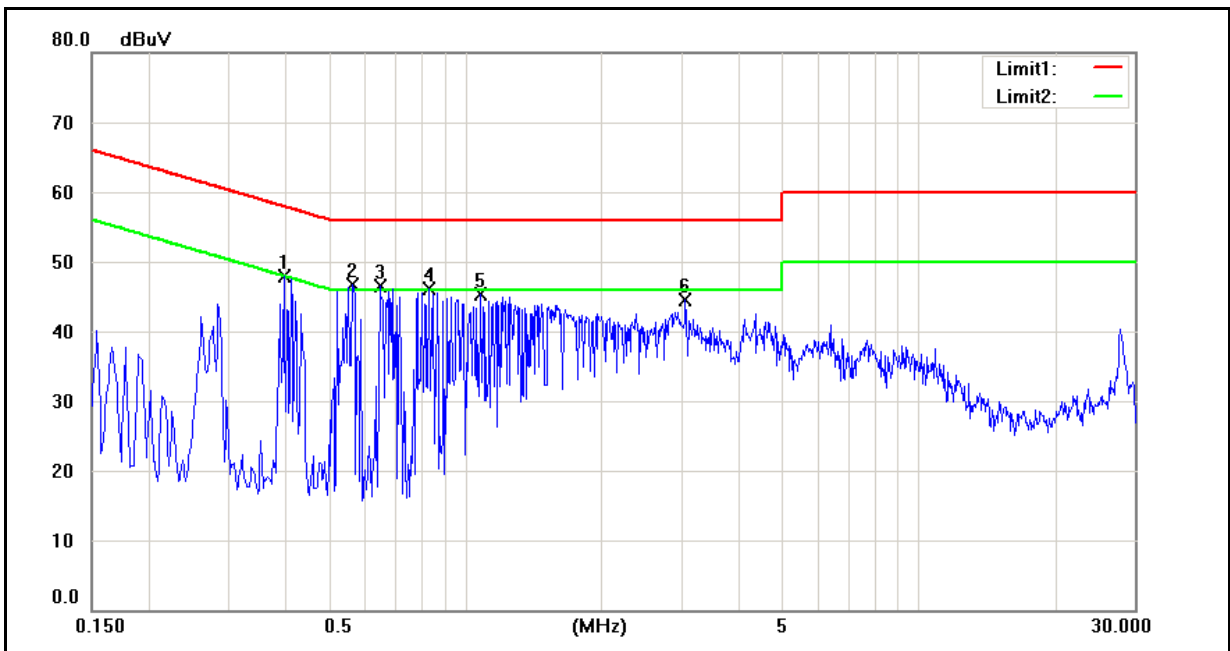

No.	Frequency (MHz)	QP reading (dBuV)	AVG reading (dBuV)	Correction factor (dB)	QP result (dBuV)	AVG result (dBuV)	QP limit (dBuV)	AVG limit (dBuV)	QP margin (dB)	AVG margin (dB)	Remark
1	0.3980	34.05	14.56	9.97	44.02	24.53	57.90	47.90	-13.88	-23.37	Pass
2	0.5660	32.13	12.91	9.90	42.03	22.81	56.00	46.00	-13.97	-23.19	Pass
3	0.6500	32.57	12.13	9.87	42.44	22.00	56.00	46.00	-13.56	-24.00	Pass
4	0.8340	31.06	9.94	9.80	40.86	19.74	56.00	46.00	-15.14	-26.26	Pass
5	1.0860	30.04	10.17	9.72	39.76	19.89	56.00	46.00	-16.24	-26.11	Pass
6	3.0700	26.30	11.54	9.81	36.11	21.35	56.00	46.00	-19.89	-24.65	Pass

Standard:	FCC Part 24	Line:	N
Test item:	Conducted Emission	Power:	AC 120V/60Hz
Model:	PG76210	Temp.(°C)/Hum.(%RH):	26(°C)/60%RH
Mode:	Mode 6	Date:	06/29/2011
		Test By:	Gary Wu
Description:			

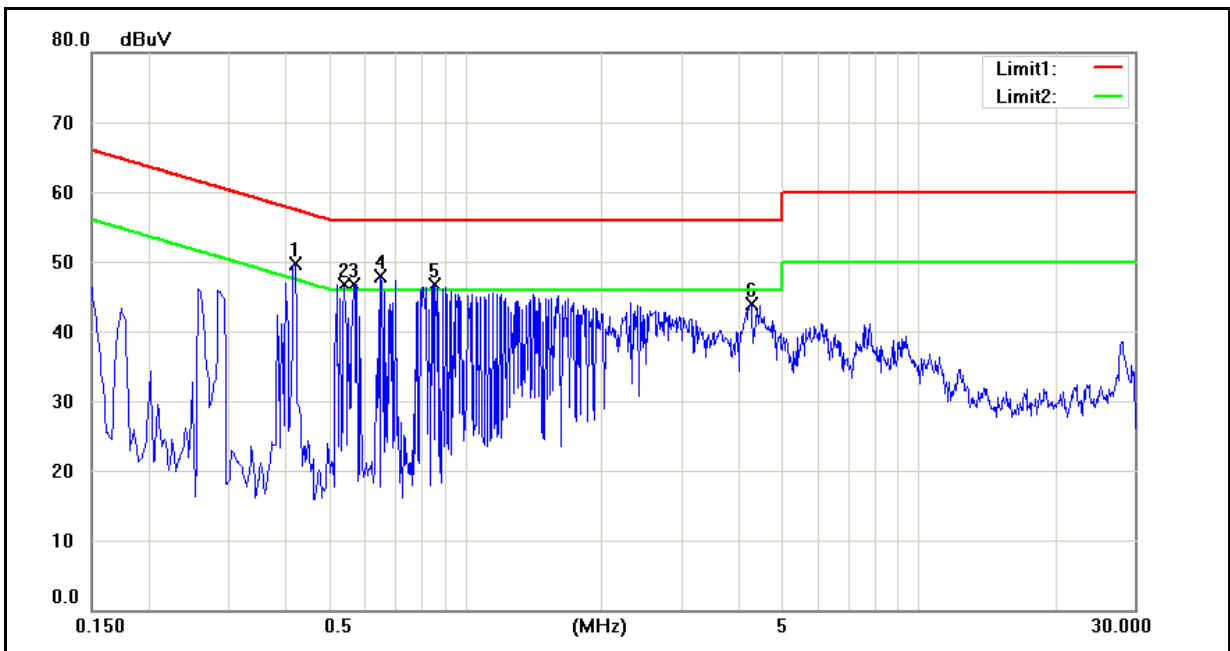

No.	Frequency (MHz)	QP reading (dBuV)	AVG reading (dBuV)	Correction factor (dB)	QP result (dBuV)	AVG result (dBuV)	QP limit (dBuV)	AVG limit (dBuV)	QP margin (dB)	AVG margin (dB)	Remark
1	0.4220	35.51	11.95	10.04	45.55	21.99	57.41	47.41	-11.86	-25.42	Pass
2	0.5420	32.21	10.26	9.99	42.20	20.25	56.00	46.00	-13.80	-25.75	Pass
3	0.5700	32.00	10.14	9.98	41.98	20.12	56.00	46.00	-14.02	-25.88	Pass
4	0.6540	33.03	9.90	9.95	42.98	19.85	56.00	46.00	-13.02	-26.15	Pass
5	0.8580	31.10	8.83	9.86	40.96	18.69	56.00	46.00	-15.04	-27.31	Pass
6	4.2860	27.10	9.74	9.88	36.98	19.62	56.00	46.00	-19.02	-26.38	Pass