

FCC 47 CFR PART 15 SUBPART C

Product Type : Smartphone

Applicant : HTC Corporation

Address : No. 23, Xinghua Rd., Taoyuan City, Taoyuan County 330,
Taiwan

Trade Name : HTC

Model Number : PG76200

Test Specification : FCC 47 CFR PART 15 SUBPART C: Oct., 2010
ANSI C63.4-2009

Issue Date : Jul. 06, 2011

Issue by

A Test Lab Techno Corp.
No. 140-1, Changan Street, Bade City,
Taoyuan County 334, Taiwan R.O.C.
Tel : +886-3-2710188 / Fax : +886-3-2710190



Taiwan Accreditation Foundation accreditation number: 1330

Note: This report shall not be reproduced except in full, without the written approval of A Test Lab Techno Corp. This document may be altered or revised by A Test Lab Techno Corp. personnel only, and shall be noted in the revision section of the document. The client should not use it to claim product endorsement by TAF, or any government agencies. The test results in the report only apply to the tested sample.

Revision History

Rev.	Issue Date	Revisions	Revised By
00	Jul. 06, 2011	Initial Issue	

Verification of Compliance

Issued Date: 07/06/2011

Product Type : Smartphone
Applicant : HTC Corporation
Address : No. 23, Xinghua Rd., Taoyuan City, Taoyuan County 330,
Taiwan
Trade Name : HTC
Model Number : PG76200
FCC ID : NM8PG76200
EUT Rated Voltage : DC 5.0V, 1.0A
Test Voltage : 120 Vac / 60 Hz
Applicable Standard : FCC 47 CFR PART 15 SUBPART C: Oct., 2010
ANSI C63.4-2009
Test Result : Complied
Performing Lab. : A Test Lab Techno Corp.

No. 140-1, Changan Street, Bade City,
Taoyuan County 334, Taiwan R.O.C.

Tel : +886-3-2710188 / Fax : +886-3-2710190

Taiwan Accreditation Foundation accreditation number:
1330



<http://www.atl-lab.com.tw/e-index.htm>

The above equipment was tested by A Test Lab Techno Corp. The test data, data evaluation, test procedures, and equipment configurations shown in this report were made in accordance with the procedures given in ANSI C63.4: 2009 and the energy emitted by the sample tested as described in this report is in compliance with the requirements of FCC Rules Part 15.207, 15.209, 15.247 .
The test results of this report relate only to the tested sample identified in this report.

Approved By
(Manager)

(Miller Lee)

Reviewed By
(Testing Engineer)



(Gary Wu)

TABLE OF CONTENTS

1	General Information	6
2	EUT Description	7
3	Test Methodology.....	8
	3.1. Mode of Operation	8
	3.2. EUT Exercise Software.....	9
	3.3. Configuration of Test System Details.....	9
	3.4. Test Site Environment.....	9
4	Conducted Emission Measurement	10
	4.1. Limit	10
	4.2. Test Instruments	10
	4.3. Test Setup.....	10
	4.4. Test Procedure.....	11
	4.5. Test Result.....	12
5	Radiated Interference Measurement	16
	5.1. Limit	16
	5.2. Test Instruments	16
	5.3. Setup	17
	5.4. Test Procedure.....	18
	5.5. Test Result.....	20
6	Maximum Conducted Output Power Measurement.....	26
	6.1. Limit	26
	6.2. Test Setup.....	26
	6.3. Test Instruments	26
	6.4. Test Procedure.....	26
	6.5. Test Result.....	27
7	Minimum 20dB RF Bandwidth Measurement	29
	7.1. Limit	29
	7.2. Test Setup.....	29
	7.3. Test Instruments	29
	7.4. Test Procedure.....	29
	7.5. Test Result.....	30
	7.6. Test Graphs	31
8	Carrier Frequency Separation Measurement	33
	8.1. Limit	33
	8.2. Test Setup.....	33
	8.3. Test Instruments	33
	8.4. Test Procedure.....	34
	8.5. Test Result.....	35
	8.6. Test Graphs	36

9	Number of Hopping Measurement	37
9.1.	Limit	37
9.2.	Test Setup.....	37
9.3.	Test Instruments	37
9.4.	Test Procedure.....	37
9.5.	Test Result.....	38
9.6.	Test Graphs	39
10	Time of Occupancy (Dwell Time) Measurement.....	41
10.1.	Limit	41
10.2.	Test Setup.....	41
10.3.	Test Instruments	41
10.4.	Test Procedure.....	41
10.5.	Test Result.....	42
10.6.	Test Graphs	44
11	Out of Band Conducted Emissions Measurement	46
11.1.	Limit	46
11.2.	Test Setup.....	46
11.3.	Test Instruments	46
11.4.	Test Procedure.....	46
11.5.	Test Graphs	47
12	Band Edges Measurement	49
12.1.	Limit	49
12.2.	Test Setup.....	49
12.3.	Test Instruments	49
12.4.	Test Procedure.....	50
12.5.	Test Result.....	51
13	99 % Occupied Bandwidth Measurement	59
13.1.	Limit	59
13.2.	Test Setup.....	59
13.3.	Test Instruments	59
13.4.	Test Procedure.....	59
13.5.	Test Result.....	60
13.6.	Test Graphs	61
14	Antenna Measurement.....	63
14.1.	Limit	63
14.2.	Antenna Connector Construction	63

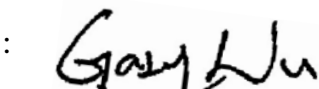
1 General Information

1.1 Summary of Test Result

Standard		Item	Result	Remark
15.247	RSS-GEN			
15.207	7.2.2	AC Power Conducted Emission	PASS	----
----	6	Receiver Radiated Emissions	PASS	----
Standard		Item	Result	Remark
15.247	RSS-210			
15.247(c)	A8.5	Transmitter Radiated Emissions	PASS	----
15.247(b)(1)	A8.4 (2)	Max. Output Power	PASS	----
15.247(a)(1)	A8.1 (1)	20dB RF Bandwidth	PASS	----
15.247(a)(1)(iii)	A8.1 (2)	Carrier Frequency Separation	PASS	----
15.247(a)(1)(iii)	A8.1 (4)	Number of Hopping	PASS	----
15.247(a)(1)(iii)	A8.1 (4)	Time of Occupancy (Dwell Time)	PASS	----
15.247(c)	A8.5	Out of Band Conducted Spurious Emission	PASS	----
15.247(c)	A8.5	Band Edge Measurement	PASS	----
15.203	-	Antenna Requirement	PASS	----

The test results of this report relate only to the tested sample(s) identified in this report. Manufacturer or whom it may concern should recognize the pass or fail of the test result.

1.2 Measurement Uncertainty

Conducted Emission

The measurement uncertainty is evaluated as ± 2.24 dB.

Radiated Emission

The measurement uncertainty of 30 MHz - 1GHz is evaluated as ± 3.072 dB.

2 EUT Description

Product	:	Smartphone		
Trade Name	:	HTC		
Model Number	:	PG76200		
Applicant	:	HTC Corporation No. 23, Xinghua Rd., Taoyuan City, Taoyuan County 330, Taiwan		
Manufacturer	:	HTC Corporation No. 23, Xinghua Rd., Taoyuan City, Taoyuan County 330, Taiwan		
FCC ID	:	NM8PG76200		
Frequency Range	:	2402 ~ 2480 MHz		
Modulation Type	:	GFSK for 1Mbps		
		$\pi/4$ -DQPSK for 2Mbps		
		8DPSK for 3Mbps		
Antenna Type	:	PIFA Type		
Antenna Gain	:	1.5 dBi		
RF Output Power (Conducted)	:	GFSK for 1Mbps	1.20 dBm /	0.00132 W
		$\pi/4$ -DQPSK for 2Mbps	3.96 dBm /	0.00249 W
		8DPSK for 3Mbps	1.91 dBm /	0.00155 W

3 Test Methodology

3.1. Mode of Operation

Decision of Test ATL has verified the construction and function in typical operation. All the test modes were carried out with the EUT in normal operation, which was shown in this test report and defined as:

Test Mode
Mode 1: IDLE Mode
Mode 2: Normal Operation Mode
Mode 3: GFSK Link Mode
Mode 4: $\pi/4$ -DQPSK Link Mode
Mode 5: 8DPSK Link Mode
Mode 6: Receiver Mode

Description of Test Modes

Preliminary tests were performed in different modulation to find the worst case. The modulation shown in the table below is the worst-case. Investigation has been done on all the possible configurations for searching the worst cases. The following table is a list of the test modes shown in this test report.

Modulation Type	Channel	Frequency (MHz)	Packet Type	Peak Conducted Power		Worst Case
				(dBm)	(W)	
GFSK	Low	2402	DH1	0.38	0.00109	<input type="checkbox"/>
	Low	2402	DH3	0.42	0.00110	<input type="checkbox"/>
	Low	2402	DH5	0.43	0.00110	<input type="checkbox"/>
	Middle	2441	DH1	1.15	0.00130	<input type="checkbox"/>
	Middle	2441	DH3	1.19	0.00132	<input type="checkbox"/>
	Middle	2441	DH5	1.20	0.00132	<input type="checkbox"/>
	High	2480	DH1	0.55	0.00114	<input type="checkbox"/>
	High	2480	DH3	0.57	0.00114	<input type="checkbox"/>
	High	2480	DH5	0.59	0.00115	<input type="checkbox"/>
$\pi/4$ -DQPSK	Low	2402	2DH1	2.95	0.00197	<input type="checkbox"/>
	Low	2402	2DH3	3.13	0.00206	<input type="checkbox"/>
	Low	2402	2DH5	3.20	0.00209	<input type="checkbox"/>
	Middle	2441	2DH1	3.81	0.00240	<input type="checkbox"/>
	Middle	2441	2DH3	3.91	0.00246	<input type="checkbox"/>
	Middle	2441	2DH5	3.96	0.00249	<input checked="" type="checkbox"/>
	High	2480	2DH1	3.41	0.00219	<input type="checkbox"/>
	High	2480	2DH3	3.42	0.00220	<input type="checkbox"/>
	High	2480	2DH5	3.44	0.00221	<input type="checkbox"/>
8DPSK	Low	2402	3DH1	1.10	0.00129	<input type="checkbox"/>
	Low	2402	3DH3	1.04	0.00127	<input type="checkbox"/>
	Low	2402	3DH5	1.09	0.00129	<input type="checkbox"/>
	Middle	2441	3DH1	1.91	0.00155	<input type="checkbox"/>
	Middle	2441	3DH3	1.72	0.00149	<input type="checkbox"/>
	Middle	2441	3DH5	1.85	0.00153	<input type="checkbox"/>
	High	2480	3DH1	1.35	0.00136	<input type="checkbox"/>
	High	2480	3DH3	1.30	0.00135	<input type="checkbox"/>
	High	2480	3DH5	1.23	0.00133	<input type="checkbox"/>

Tested System Details

The types for all equipments, plus descriptions of all cables used in the tested system (including inserted cards) are:

	Product	Manufacturer	Model Number	Serial Number	Power Cord
1.	Bluetooth Tester	R & S	CBT	100350	NA

3.2. EUT Exercise Software

1.	Setup the EUT and Bluetooth Tester (CBT) as shown on 3.3.
2.	Turn on the power of all equipment.
3.	EUT run test program.
4.	Open Bluetooth function link to CBT.

3.3. Configuration of Test System Details

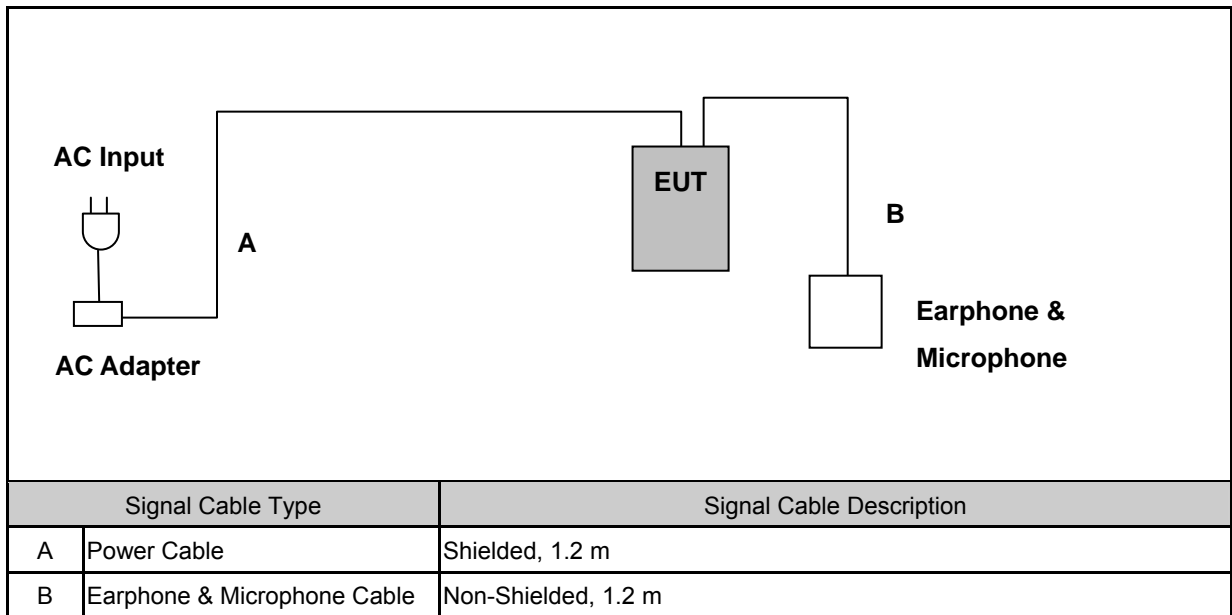

3.4. Test Site Environment

Items	Required (IEC 68-1)	Actual
Temperature (°C)	15-35	26
Humidity (%RH)	25-75	60
Barometric pressure (mbar)	860-1060	950

4 Conducted Emission Measurement

4.1. Limit

Frequency (MHz)	Quasi-peak	Average
0.15 - 0.5	66 to 56	56 to 46
0.50 - 5.0	56	46
5.0 - 30.0	60	50

4.2. Test Instruments

Describe	Manufacturer	Model Number	Serial Number	Cal. Date	Remark
Test Receiver	R&S	ESCI	100367	07/01/2010	(1)
LISN	R&S	ENV216	101040	03/04/2011	(1)
LISN	R&S	ENV216	101041	03/04/2011	(1)
Test Site	ATL	TE05	TE05	N.C.R.	-----

Remark: (1) Calibration period 1 year. (2) Calibration period 2 years.

NOTE: N.C.R. = No Calibration Request.

4.3. Test Setup

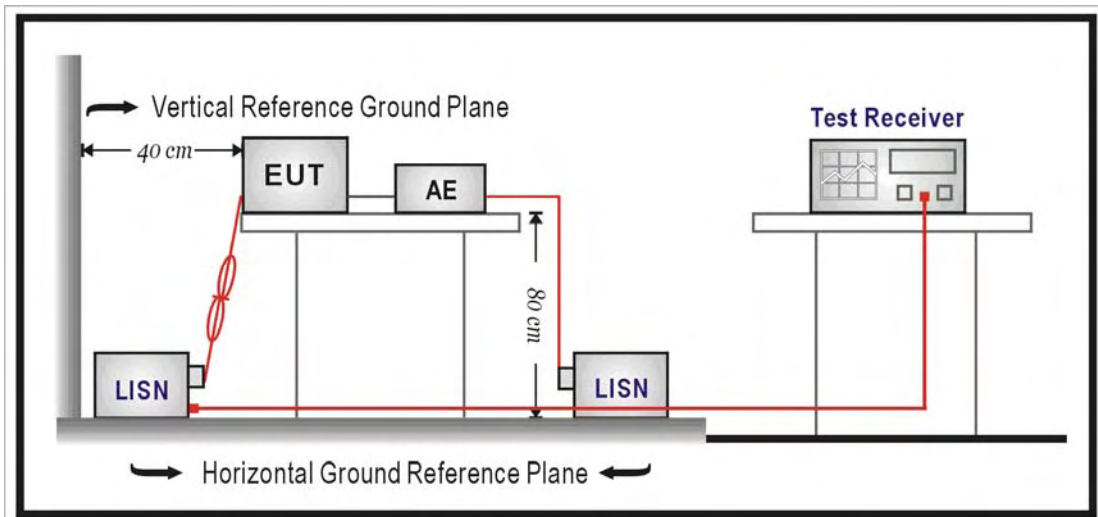

4.4. Test Procedure

The power line conducted emission measurements were performed in a shielded enclosure. The EUT was assembled on a wooden table which is 80 centimeters high, was placed 40 centimeters from the back wall and at least 1 meter from the sidewall.

Power was fed to the EUT from the public utility power grid through a line filter and EMCO Model 3162/2 SH Line Impedance Stabilization Networks (LISN). The LISN housing, measuring instrumentation case, ground plane, etc., were electrically bonded together at the same RF potential. The Spectrum analyzer was connected to the AC line through an isolation transformer. The 50-ohm output of the LISN was connected to the spectrum analyzer directly. Conducted emission levels were in the CISPR quasi-peak detection mode. The analyzer's 6 dB bandwidth was set to 9 KHz. No post-detector video filter was used.

The spectrum was scanned from 150 KHz to 30 MHz. The physical arrangement of the test system and associated cabling was varied (within the scope of arrangements likely to be encountered in actual use) to determine the effect on the unit's emanations in amplitude and frequency. All spurious emission frequencies were observed. The highest emission amplitudes relative to the appropriate limit were measured and have been recorded in paragraph 4.1.

4.5. Test Result

Standard:	FCC Part 15C	Line:	L1
Test item:	Conducted Emission	Power:	AC 120V/60Hz
Model Number:	PG76200	Temp.(°C)/Hum.(%RH):	26(°C)/60%RH
Mode:	Mode 1	Date:	06/21/2011
		Test By:	Gary Wu
Description:			

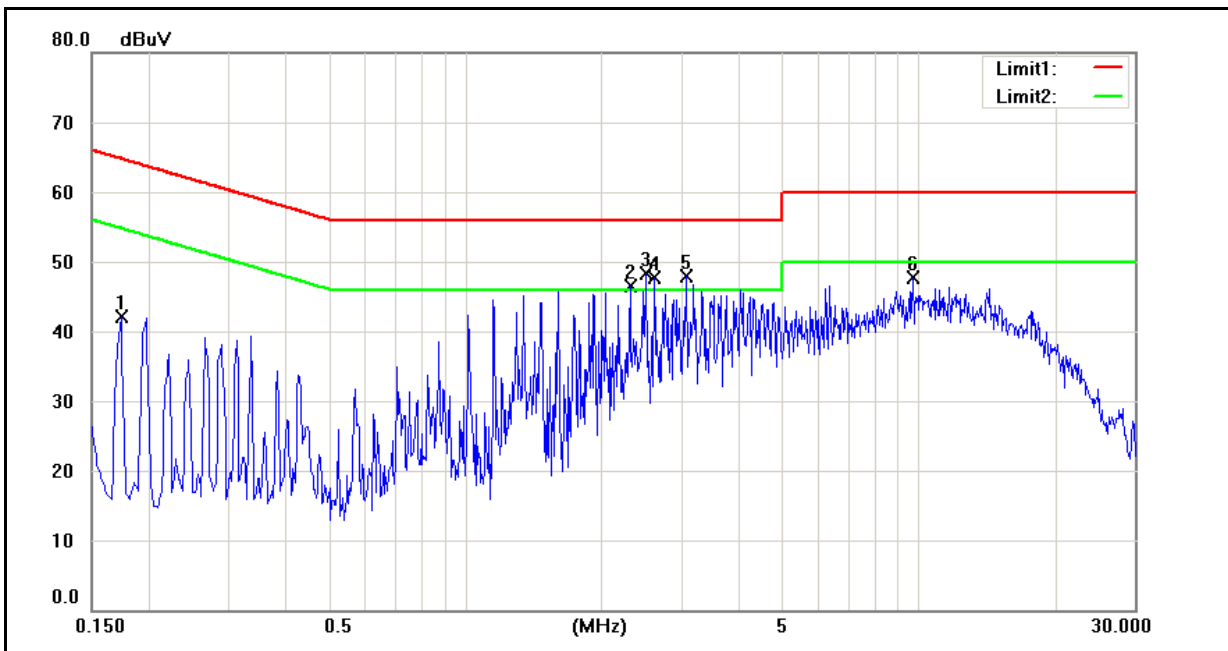

No.	Frequency (MHz)	QP reading (dBuV)	AVG reading (dBuV)	Correction factor (dB)	QP result (dBuV)	AVG result (dBuV)	QP limit (dBuV)	AVG limit (dBuV)	QP margin (dB)	AVG margin (dB)	Remark
1	0.1740	27.54	10.00	10.06	37.60	20.06	64.77	54.77	-27.17	-34.71	Pass
2	2.3100	33.04	23.54	9.72	42.76	33.26	56.00	46.00	-13.24	-12.74	Pass
3	2.5020	31.98	20.05	9.74	41.72	29.79	56.00	46.00	-14.28	-16.21	Pass
4	2.6180	31.45	21.23	9.75	41.20	30.98	56.00	46.00	-14.80	-15.02	Pass
5	3.0780	32.14	20.58	9.81	41.95	30.39	56.00	46.00	-14.05	-15.61	Pass
6	9.7220	29.00	20.76	10.15	39.15	30.91	60.00	50.00	-20.85	-19.09	Pass

Standard:	FCC Part 15C	Line:	N
Test item:	Conducted Emission	Power:	AC 120V/60Hz
Model Number:	PG76200	Temp.(°C)/Hum.(%RH):	26(°C)/60%RH
Mode:	Mode 1	Date:	06/21/2011
		Test By:	Gary Wu
Description:			

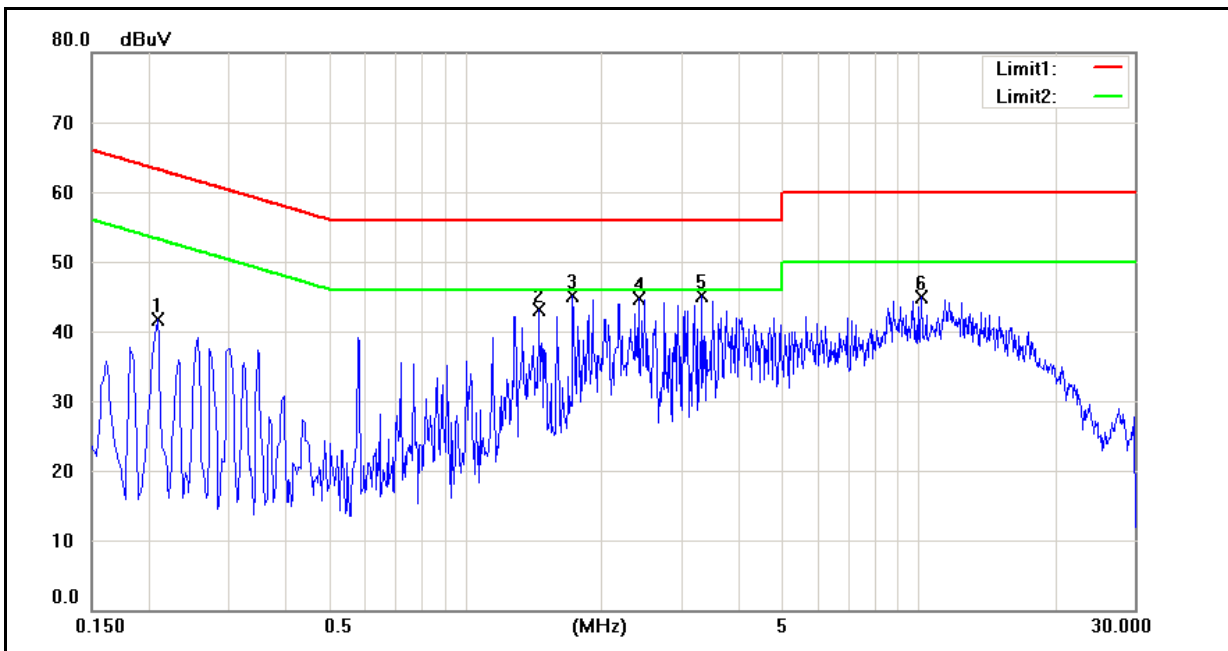

No.	Frequency (MHz)	QP reading (dBuV)	AVG reading (dBuV)	Correction factor (dB)	QP result (dBuV)	AVG result (dBuV)	QP limit (dBuV)	AVG limit (dBuV)	QP margin (dB)	AVG margin (dB)	Remark
1	0.2100	21.78	7.11	10.13	31.91	17.24	63.21	53.21	-31.30	-35.97	Pass
2	1.4580	25.33	14.26	9.75	35.08	24.01	56.00	46.00	-20.92	-21.99	Pass
3	1.7340	31.74	21.48	9.75	41.49	31.23	56.00	46.00	-14.51	-14.77	Pass
4	2.4180	24.57	17.03	9.79	34.36	26.82	56.00	46.00	-21.64	-19.18	Pass
5	3.3340	30.00	19.12	9.86	39.86	28.98	56.00	46.00	-16.14	-17.02	Pass
6	10.1740	24.25	16.94	10.26	34.51	27.20	60.00	50.00	-25.49	-22.80	Pass

Standard:	FCC Part 15C	Line:	L1
Test item:	Conducted Emission	Power:	AC 120V/60Hz
Model Number:	PG76200	Temp.(°C)/Hum.(%RH):	26(°C)/60%RH
Mode:	Mode 2	Date:	06/29/2011
		Test By:	Gary Wu
Description:			

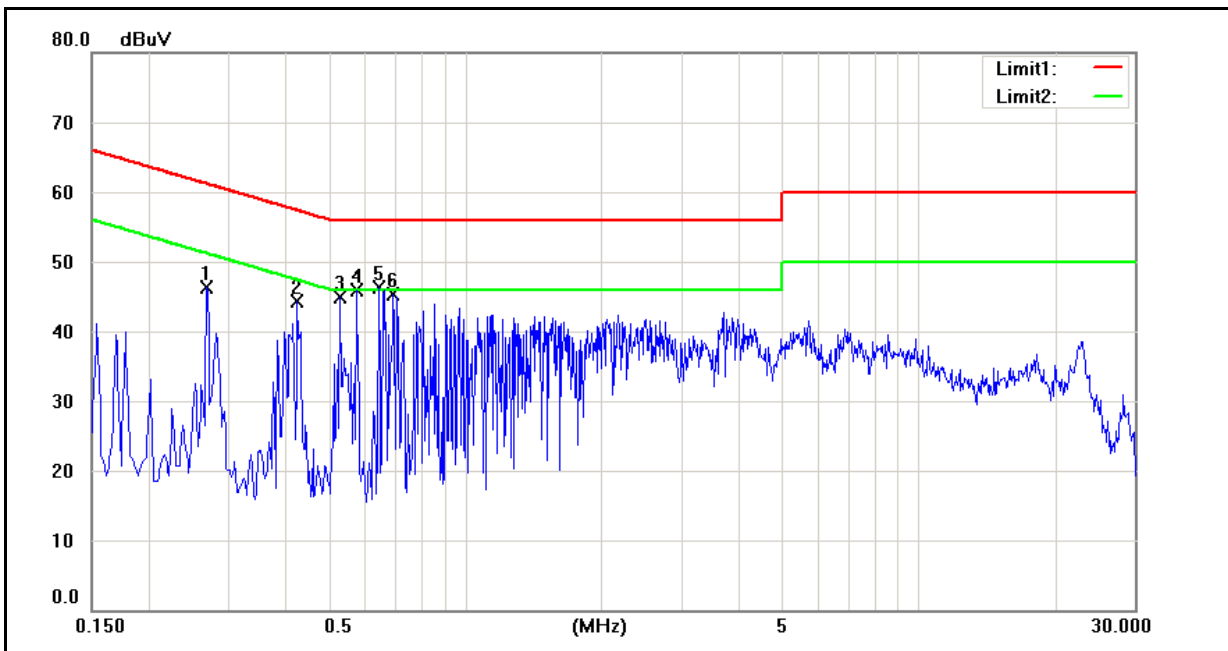

No.	Frequency (MHz)	QP reading (dBuV)	AVG reading (dBuV)	Correction factor (dB)	QP result (dBuV)	AVG result (dBuV)	QP limit (dBuV)	AVG limit (dBuV)	QP margin (dB)	AVG margin (dB)	Remark
1	0.2700	32.40	13.88	10.02	42.42	23.90	61.12	51.12	-18.70	-27.22	Pass
2	0.4260	30.38	13.96	9.96	40.34	23.92	57.33	47.33	-16.99	-23.41	Pass
3	0.5300	33.22	12.70	9.92	43.14	22.62	56.00	46.00	-12.86	-23.38	Pass
4	0.5780	32.15	11.25	9.90	42.05	21.15	56.00	46.00	-13.95	-24.85	Pass
5	0.6460	33.38	12.21	9.87	43.25	22.08	56.00	46.00	-12.75	-23.92	Pass
6	0.6940	32.97	13.28	9.85	42.82	23.13	56.00	46.00	-13.18	-22.87	Pass

Standard:	FCC Part 15C	Line:	N
Test item:	Conducted Emission	Power:	AC 120V/60Hz
Model Number:	PG76200	Temp.(°C)/Hum.(%RH):	26(°C)/60%RH
Mode:	Mode 2	Date:	06/29/2011
		Test By:	Gary Wu
Description:			

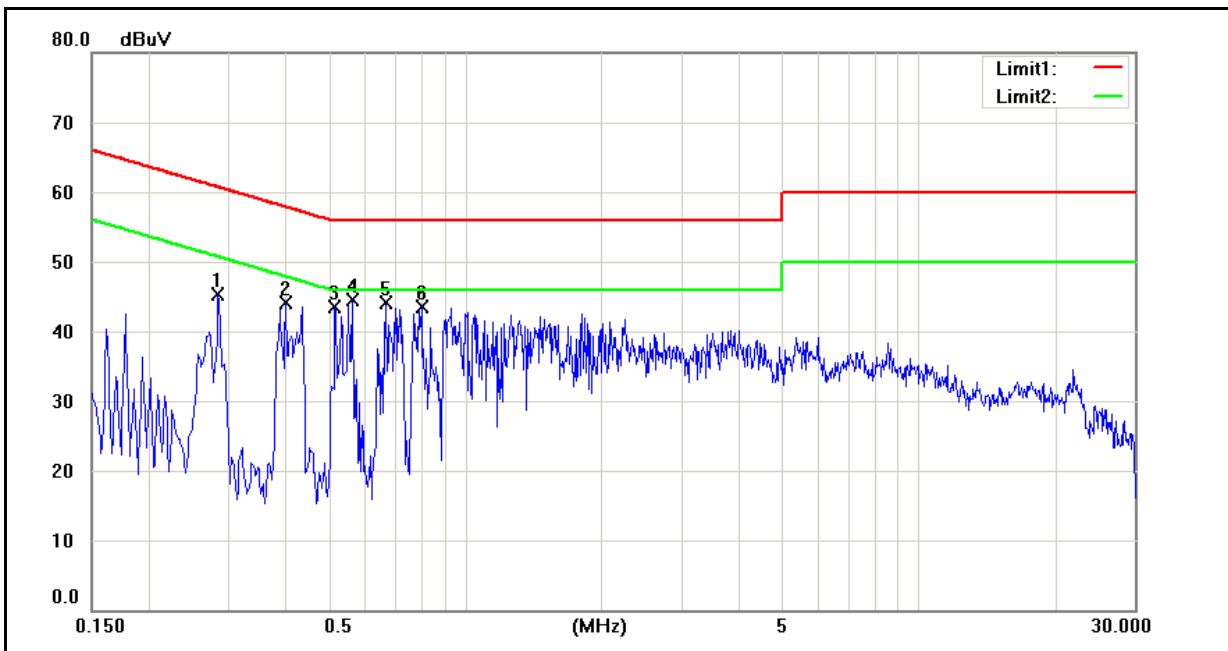

No.	Frequency (MHz)	QP reading (dBuV)	AVG reading (dBuV)	Correction factor (dB)	QP result (dBuV)	AVG result (dBuV)	QP limit (dBuV)	AVG limit (dBuV)	QP margin (dB)	AVG margin (dB)	Remark
1	0.2860	31.51	15.49	10.10	41.61	25.59	60.64	50.64	-19.03	-25.05	Pass
2	0.4020	29.93	14.75	10.05	39.98	24.80	57.81	47.81	-17.83	-23.01	Pass
3	0.5180	31.76	14.41	10.00	41.76	24.41	56.00	46.00	-14.24	-21.59	Pass
4	0.5660	31.62	14.73	9.98	41.60	24.71	56.00	46.00	-14.40	-21.29	Pass
5	0.6700	32.10	12.66	9.94	42.04	22.60	56.00	46.00	-13.96	-23.40	Pass
6	0.8020	30.99	13.17	9.88	40.87	23.05	56.00	46.00	-15.13	-22.95	Pass

5 Radiated Interference Measurement

5.1. Limit

Frequency Range (MHz)	Peak (dBuV)
30 to 88	39
88 to 216	43.5
216 to 960	46.4
Above 960	49.5

5.2. Test Instruments

3 Meter Chamber					
Equipment	Manufacturer	Model Number	Serial Number	Cal. Date	Remark
Spectrum Analyzer	Agilent	E4445A	MY46181986	06/16/2011	(1)
Amplifier	Mini-Circuits	ZKL-1R5+	N/A	05/30/2011	(1)
Amplifier	Mini-Circuits	ZVA-213-S+	N/A	05/30/2011	(1)
RF Pre-selector	Agilent	N9039A	MY46520255	05/16/2011	(1)
Double-Ridged Waveguide Horn	ETS-Lindgren	3117	00128055	08/24/2010	(1)
Trilog-Broadband Antenna	Schwarzbeck Mess-Elektronik	SB AC VULB	9168-419	05/10/2011	(1)
Test Site	ATL	TE09	TE09	05/13/2011	(1)

Remark: (1) Calibration period 1 year. (2) Calibration period 2 years.

NOTE: N.C.R. = No Calibration Request.

5.3. Setup

Below 1GHz

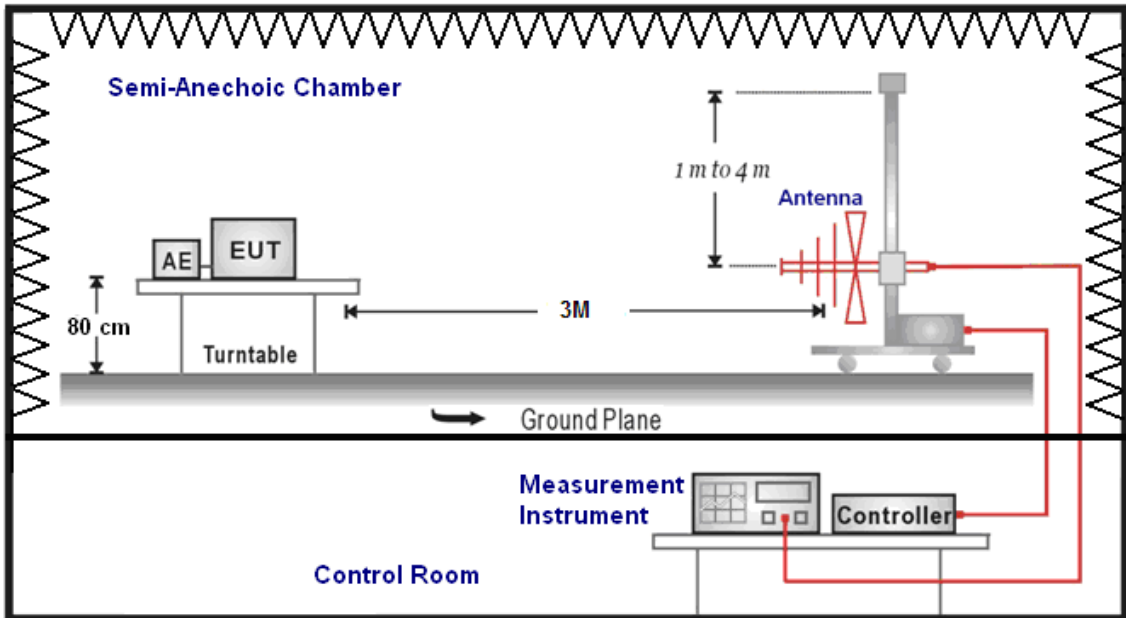

Above 1GHz

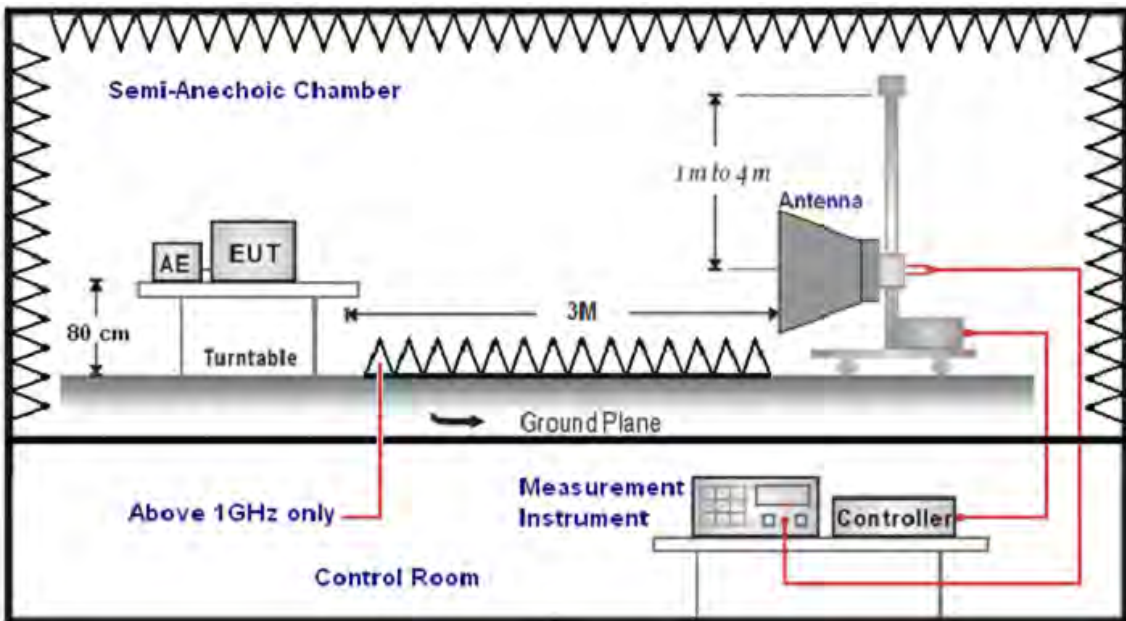

5.4. Test Procedure

Final radiation measurements were made on a three-meter, Semi Anechoic Chamber. The EUT system was placed on a nonconductive turntable which is 0.8 meters height, top surface 1.0 x 1.5 meter. The spectrum was examined from 250 MHz to 2.5 GHz in order to cover the whole spectrum below 10th harmonic which could generate from the EUT. During the test, EUT was set to transmit continuously & Measurements spectrum range from 30 MHz to 26.5 GHz is investigated.

For measurements below 1 GHz the resolution bandwidth is set to 100 kHz for peak detection measurements or 120 kHz for quasi-peak detection measurements. Peak detection is used unless otherwise noted as quasi-peak.

For measurements above 1 GHz the resolution bandwidth is set to 1 MHz, and then the video bandwidth is set to 1 MHz for peak measurements and 10 Hz for average measurements.

A nonconductive material surrounded the EUT to supporting the EUT for standing on three orthogonal planes. At each condition, the EUT was rotated 360 degrees, and the antenna was raised and lowered from one to four meters to find the maximum emission levels. Measurements were taken using both horizontal and vertical antenna polarization.

SCHWARZBECK MESS-ELEKTRONIK Biconilog Antenna (mode VULB9163) at 3 Meter and the SCHWARZBECK Double Ridged Guide Antenna (model BBHA9120D&9170) was used in frequencies 1 – 26.5 GHz at a distance of 1 meter. All test results were extrapolated to equivalent signal at 3 meters utilizing an inverse linear distance extrapolation Factor (20dB/decade).

For testing above 1GHz, the emission level of the EUT in peak mode was 20dB lower than average limit (that means the emission level in peak mode also complies with the limit in average mode), then testing will be stopped and peak values of EUT will be reported, otherwise, the emissions will be measured in average mode again and reported.

Appropriate preamplifiers were used for improving sensitivity and precautions were taken to avoid overloading or desensitizing the spectrum analyzer. No post – detector video filters were used in the test.

The spectrum analyzer's 6 dB bandwidth was set to 1 MHz, and the analyzer was operated in the peak detection mode, for frequencies both below and up 1 GHz. The average levels were obtained by subtracting the duty cycle correction factor from the peak readings.

The following procedures were used to convert the emission levels measured in decibels referenced to 1 microvolt (dBuV) into field intensity in micro volts pre meter ($\mu\text{V}/\text{m}$).

The actual field intensity in decibels referenced to 1 microvolt in to field intensity in micro volts per meter (dBuV/m).

The actual field intensity in referenced to 1 microvolt per meter (dBuV/m) is determined by algebraically adding the measured reading in dBuV, the antenna factor (dB), and cable loss (dB) and Subtracting the gain of preamplifier (dB) is auto calculate in spectrum analyzer.

(1) $\text{Amplitude (dBuV/m)} = \text{FI (dBuV)} + \text{AF (dBuV)} + \text{CL (dBuV)} - \text{Gain (dB)}$

FI= Reading of the field intensity.

AF= Antenna factor.

CL= Cable loss.

P.S Amplitude is auto calculate in spectrum analyzer.

(2) $\text{Actual Amplitude (dBuV/m)} = \text{Amplitude (dBuV)} - \text{Dis(dB)}$

The FCC specified emission limits were calculated according the EUT operating frequency and by following linear interpolation equations:

(a) For fundamental frequency : Transmitter Output < +30dBm

(b) For spurious frequency : Spurious emission limits = fundamental emission limit /10

5.5. Test Result

Below 1GHz

Standard:	FCC Part 15C	Test Distance:	3m
Test item:	Radiated Emission	Power:	AC 120V/60Hz
Model Number:	PG76200	Temp.(°C)/Hum.(%RH):	26(°C)/60%RH
Mode:	Mode 2	Date:	06/20/2011
Ant.Polar.:	Horizontal	Test By:	Gary Wu

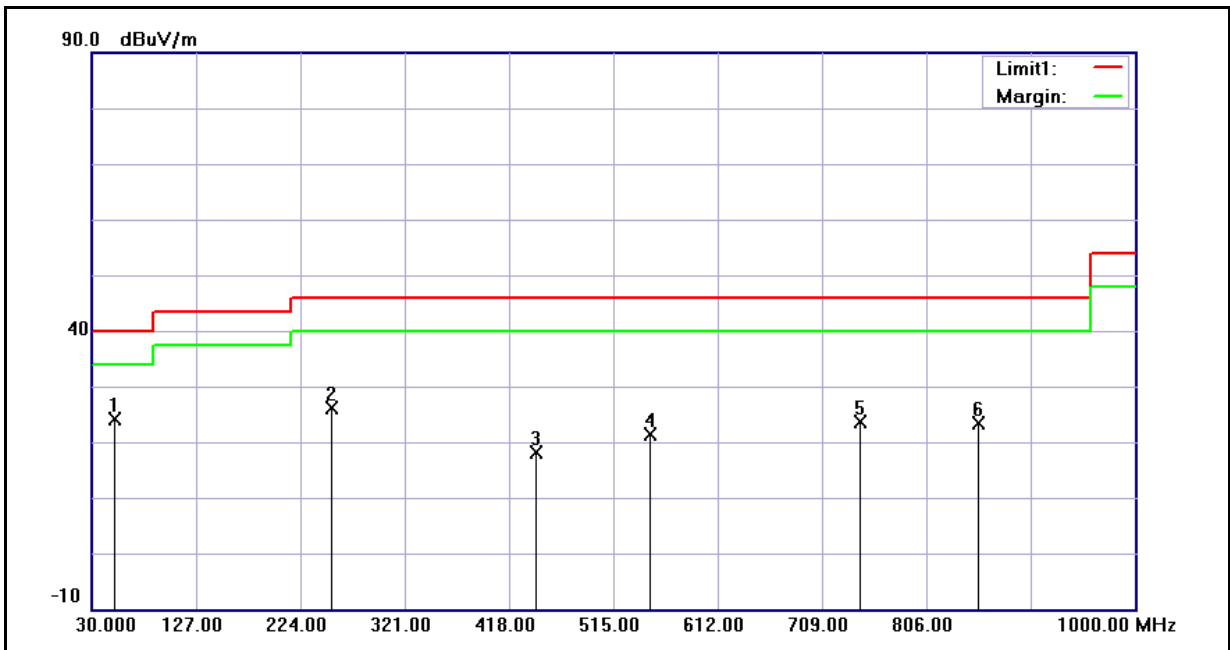

No.	Frequency (MHz)	Reading (dBuV)	Correct Factor(dB/m)	Result (dBuV/m)	Limit (dBuV/m)	Margin (dB)	Remark
1	51.5000	48.91	-24.90	24.01	40.00	-15.99	QP
2	253.5000	50.89	-24.68	26.21	46.00	-19.79	QP
3	443.5000	37.17	-18.92	18.25	46.00	-27.75	QP
4	549.0000	38.21	-16.85	21.36	46.00	-24.64	QP
5	745.5000	36.46	-12.85	23.61	46.00	-22.39	QP
6	854.5000	35.43	-12.00	23.43	46.00	-22.57	QP

Standard:	FCC Part 15C	Test Distance:	3m
Test item:	Radiated Emission	Power:	AC 120V/60Hz
Model Number:	PG76200	Temp.(°C)/Hum.(%RH):	26(°C)/60%RH
Mode:	Mode 2	Date:	06/20/2011
Ant.Polar.:	Vertical	Test By:	Gary Wu

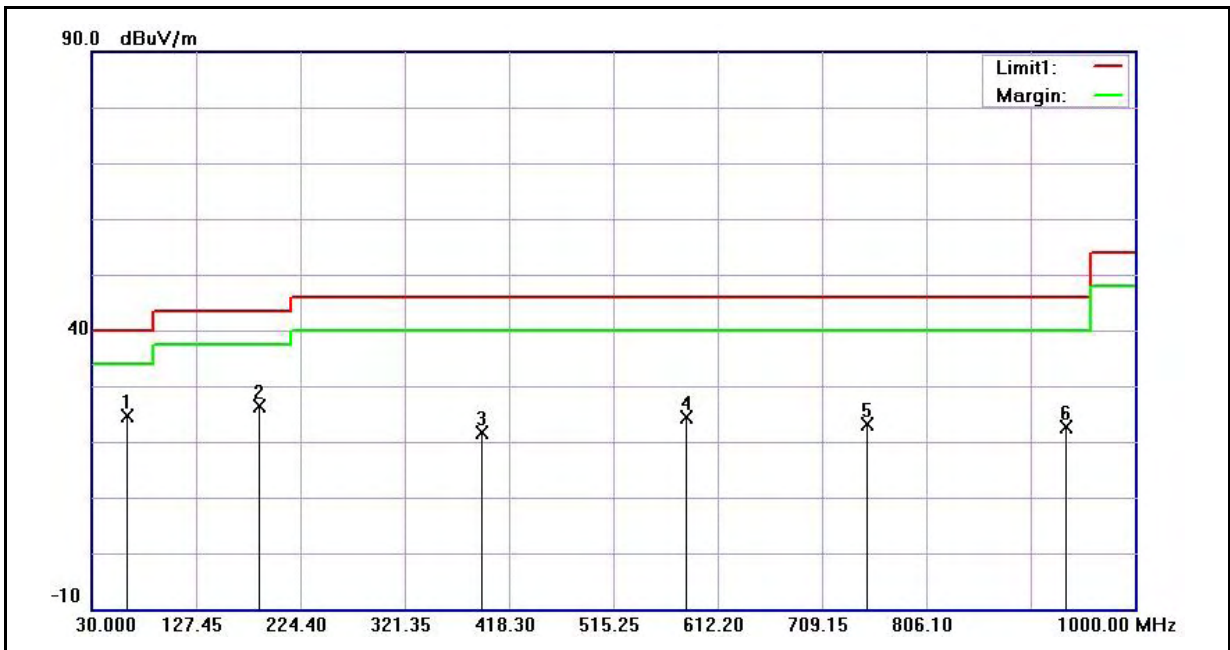

No.	Frequency (MHz)	Reading (dBuV)	Correct Factor(dB/m)	Result (dBuV/m)	Limit (dBuV/m)	Margin (dB)	Remark
1	63.5000	50.59	-26.07	24.52	40.00	-15.48	QP
2	187.0000	52.74	-26.29	26.45	43.50	-17.05	QP
3	393.5000	41.98	-20.35	21.63	46.00	-24.37	QP
4	583.0000	40.20	-15.90	24.30	46.00	-21.70	QP
5	751.0000	35.90	-12.72	23.18	46.00	-22.82	QP
6	936.0000	33.27	-10.76	22.51	46.00	-23.49	QP

Above 1GHz

Standard:	FCC Part 15C			Test Distance:	3m		
Test item:	Radiated Emission			Power:	AC 120V/60Hz		
Model Number:	PG76200			Temp.(°C)/Hum.(%RH):	26(°C)/60%RH		
Mode:	Mode 3			Date:	06/20/2011		
Frequency:	2402 MHz			Test By:	Gary Wu		
Frequency (MHz)	Reading (dBuV)	Correct Factor(dB/m)	Result (dBuV/m)	Limit (dBuV/m)	Margin (dB)	Remark	Ant.Polar. H / V
3114.000	61.91	-15.88	46.03	74.00	-27.97	peak	H
5011.000	59.77	-10.90	48.87	74.00	-25.13	peak	H
6474.000	58.55	-7.41	51.14	74.00	-22.86	peak	H
2554.000	63.48	-17.46	46.02	74.00	-27.98	peak	V
4745.000	59.78	-11.44	48.34	74.00	-25.66	peak	V
6740.000	58.38	-6.94	51.44	74.00	-22.56	peak	V

Standard:	FCC Part 15C			Test Distance:	3m		
Test item:	Radiated Emission			Power:	AC 120V/60Hz		
Model Number:	PG76200			Temp.(°C)/Hum.(%RH):	26(°C)/60%RH		
Mode:	Mode 3			Date:	06/20/2011		
Frequency:	2441 MHz			Test By:	Gary Wu		
Frequency (MHz)	Reading (dBuV)	Correct Factor(dB/m)	Result (dBuV/m)	Limit (dBuV/m)	Margin (dB)	Remark	Ant.Polar. H / V
2652.000	62.84	-17.16	45.68	74.00	-28.32	peak	H
5116.000	59.16	-10.64	48.52	74.00	-25.48	peak	H
6670.000	58.97	-7.07	51.90	74.00	-22.10	peak	H
3051.000	62.26	-15.99	46.27	74.00	-27.73	peak	V
4815.000	59.35	-11.30	48.05	74.00	-25.95	peak	V
6411.000	58.00	-7.52	50.48	74.00	-23.52	peak	V

Standard:	FCC Part 15C			Test Distance:	3m		
Test item:	Radiated Emission			Power:	AC 120V/60Hz		
Model Number:	PG76200			Temp.(°C)/Hum.(%RH):	26(°C)/60%RH		
Mode:	Mode 3			Date:	06/20/2011		
Frequency:	2480 MHz			Test By:	Gary Wu		
Frequency (MHz)	Reading (dBuV)	Correct Factor(dB/m)	Result (dBuV/m)	Limit (dBuV/m)	Margin (dB)	Remark	Ant.Polar. H / V
3254.000	61.64	-15.65	45.99	74.00	-28.01	peak	H
4752.000	60.20	-11.43	48.77	74.00	-25.23	peak	H
6453.000	57.46	-7.45	50.01	74.00	-23.99	peak	H
2757.000	63.48	-16.83	46.65	74.00	-27.35	peak	V
5095.000	59.13	-10.70	48.43	74.00	-25.57	peak	V
6565.000	58.82	-7.25	51.57	74.00	-22.43	peak	V

Standard:	FCC Part 15C			Test Distance:	3m		
Test item:	Radiated Emission			Power:	AC 120V/60Hz		
Model Number:	PG76200			Temp.(°C)/Hum.(%RH):	26(°C)/60%RH		
Mode:	Mode 4			Date:	06/20/2011		
Frequency:	2402 MHz			Test By:	Gary Wu		
Frequency (MHz)	Reading (dBuV)	Correct Factor(dB/m)	Result (dBuV/m)	Limit (dBuV/m)	Margin (dB)	Remark	Ant.Polar. H / V
2792.000	62.48	-16.71	45.77	74.00	-28.23	peak	H
5186.000	59.29	-10.48	48.81	74.00	-25.19	peak	H
6985.000	58.48	-6.53	51.95	74.00	-22.05	peak	H
2757.000	62.75	-16.83	45.92	74.00	-28.08	peak	V
4227.000	61.19	-12.91	48.28	74.00	-25.72	peak	V
6152.000	59.22	-8.00	51.22	74.00	-22.78	peak	V

Standard:	FCC Part 15C			Test Distance:	3m		
Test item:	Radiated Emission			Power:	AC 120V/60Hz		
Model Number:	PG76200			Temp.(°C)/Hum.(%RH):	26(°C)/60%RH		
Mode:	Mode 4			Date:	06/20/2011		
Frequency:	2441 MHz			Test By:	Gary Wu		
Frequency (MHz)	Reading (dBuV)	Correct Factor(dB/m)	Result (dBuV/m)	Limit (dBuV/m)	Margin (dB)	Remark	Ant.Polar. H / V
2792.000	62.75	-16.71	46.04	74.00	-27.96	peak	H
4108.000	61.09	-13.33	47.76	74.00	-26.24	peak	H
6040.000	58.50	-8.20	50.30	74.00	-23.70	peak	H
2932.000	62.43	-16.28	46.15	74.00	-27.85	peak	V
4640.000	59.74	-11.67	48.07	74.00	-25.93	peak	V
6320.000	57.34	-7.69	49.65	74.00	-24.35	peak	V

Standard:	FCC Part 15C			Test Distance:	3m		
Test item:	Radiated Emission			Power:	AC 120V/60Hz		
Model Number:	PG76200			Temp.(°C)/Hum.(%RH):	26(°C)/60%RH		
Mode:	Mode 4			Date:	06/20/2011		
Frequency:	2480 MHz			Test By:	Gary Wu		
Frequency (MHz)	Reading (dBuV)	Correct Factor(dB/m)	Result (dBuV/m)	Limit (dBuV/m)	Margin (dB)	Remark	Ant.Polar. H / V
3044.000	62.03	-16.00	46.03	74.00	-27.97	peak	H
4955.000	60.01	-11.02	48.99	74.00	-25.01	peak	H
6670.000	58.26	-7.07	51.19	74.00	-22.81	peak	H
2470.000	63.75	-17.66	46.09	74.00	-27.91	peak	V
4794.000	60.13	-11.34	48.79	74.00	-25.21	peak	V
6173.000	58.51	-7.96	50.55	74.00	-23.45	peak	V

Standard:	FCC Part 15C			Test Distance:	3m			
Test item:	Radiated Emission			Power:	AC 120V/60Hz			
Model Number:	PG76200			Temp.(°C)/Hum.(%RH):	26(°C)/60%RH			
Mode:	Mode 6			Date:	06/20/2011			
Frequency:	2441 MHz			Test By:	Gary Wu			
Frequency (MHz)	Reading (dBuV)	Correct Factor(dB/m)	Result (dBuV/m)	Peak Limit (dBuV/m)	AVG. Limit (dBuV/m)	Margin (dB)	Remark	Ant.Polar. H / V
2183.000	62.96	-18.06	44.90	74.00	54.00	-29.10	peak	H
4738.000	62.02	-11.46	50.56	74.00	54.00	-23.44	peak	H
6558.000	58.16	-7.26	50.90	74.00	54.00	-23.10	peak	H
2323.000	62.65	-17.86	44.79	74.00	54.00	-29.21	peak	V
3905.000	60.44	-13.99	46.45	74.00	54.00	-27.55	peak	V
6236.000	57.07	-7.84	49.23	74.00	54.00	-24.77	peak	V

6 Maximum Conducted Output Power Measurement

6.1. Limit

For frequency hopping systems operating in the 2400–2483.5 MHz band employing at least 75 non-overlapping hopping channels < 1 watt.

6.2. Test Setup

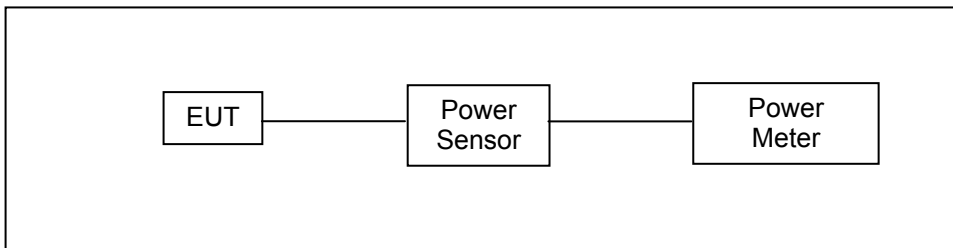

6.3. Test Instruments

Equipment	Manufacturer	Model Number	Serial Number	Cal. Date	Remark
Single Channel PK Power Sensor	Agilent	N1911A	MY45101619	07/19/2010	(1)
Wideband Power Meter	Agilent	N1921A	MY45241957	07/19/2010	(1)
Test Site	ATL	TE02	TE02	N.C.R.	----

Remark: (1) Calibration period 1 year. (2) Calibration period 2 years.

NOTE: N.C.R. = No Calibration Request.

6.4. Test Procedure

The tests below are run with the EUT's transmitter set at high power in TX mode. The EUT is needed to force selection of output power level and channel number. While testing, EUT was set to transmit continuously. Remove the Subjective device's antenna and connect the RF output port to power sensor. The maximum peak output power shall not exceed 1 watt.

Use a direct connection between the antenna port of transmitter and the power sensor, for prevent the power sensor input attenuation 40-50 dB. Set the RBW Bandwidth of the emission or use a channel power meter mode.

For antennas with gains of 6 dBi or less, maximum allowed transmitter output is 1 watt (+30 dBm). For antennas with gains greater than 6 dBi, transmitter output level must be decreased by an amount equal to (GAIN - 6)/3 dBm.

The antenna port of the EUT was connected to the input of a power sensor. Power was read directly and cable loss correction was added to the reading to obtain power at the EUT antenna terminals.

6.5. Test Result

Model Number	PG76200					
Test Item	Maximum Conducted Output Power					
Test Mode	Mode 3: GFSK Link Mode					
Date of Test	06/20/2011			Test Site	TE02	
Frequency (MHz)	Packet Type	Average Power		Peak Power		Limit (W)
		(dBm)	(W)	(dBm)	(W)	
2402	DH1	-8.27	0.00015	0.38	0.00109	< 1
	DH3	-4.89	0.00032	0.42	0.00110	< 1
	DH5	-4.43	0.00036	0.43	0.00110	< 1
2441	DH1	-7.45	0.00018	1.15	0.00130	< 1
	DH3	-4.13	0.00039	1.19	0.00132	< 1
	DH5	-3.52	0.00044	1.20	0.00132	< 1
2480	DH1	-8.08	0.00016	0.55	0.00114	< 1
	DH3	-4.66	0.00034	0.57	0.00114	< 1
	DH5	-4.15	0.00038	0.59	0.00115	< 1

Model Number	PG76200					
Test Item	Maximum Conducted Output Power					
Test Mode	Mode 4: $\pi/4$ -DQPSK Mode					
Date of Test	06/20/2011			Test Site	TE02	
Frequency (MHz)	Packet Type	Average Power		Peak Power		Limit (W)
		(dBm)	(W)	(dBm)	(W)	
2402	DH1	-8.13	0.00015	2.95	0.00197	< 1
	DH3	-4.76	0.00033	3.13	0.00206	< 1
	DH5	-4.21	0.00038	3.20	0.00209	< 1
2441	DH1	-7.29	0.00019	3.81	0.00240	< 1
	DH3	-3.89	0.00041	3.91	0.00246	< 1
	DH5	-3.31	0.00047	3.96	0.00249	< 1
2480	DH1	-7.92	0.00016	3.41	0.00219	< 1
	DH3	-4.57	0.00035	3.42	0.00220	< 1
	DH5	-3.87	0.00041	3.44	0.00221	< 1

Model Number	PG76200					
Test Item	Maximum Conducted Output Power					
Test Mode	Mode 5: 8DPSK Link Mode					
Date of Test	06/20/2011			Test Site	TE02	
Frequency (MHz)	Packet Type	Average Power		Peak Power		Limit (W)
		(dBm)	(W)	(dBm)	(W)	
2402	DH1	-10.77	0.00008	1.10	0.00129	< 1
	DH3	-7.43	0.00018	1.04	0.00127	< 1
	DH5	-6.91	0.00020	1.09	0.00129	< 1
2441	DH1	-10.18	0.00010	1.91	0.00155	< 1
	DH3	-6.65	0.00022	1.72	0.00149	< 1
	DH5	-6.11	0.00024	1.85	0.00153	< 1
2480	DH1	-10.69	0.00009	1.35	0.00136	< 1
	DH3	-7.25	0.00019	1.30	0.00135	< 1
	DH5	-6.74	0.00021	1.23	0.00133	< 1

7 Minimum 20dB RF Bandwidth Measurement

7.1. Limit

N/A

7.2. Test Setup

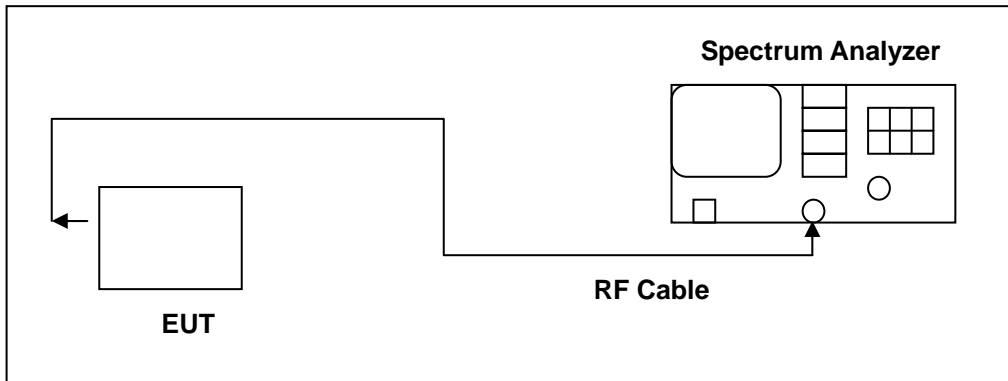

7.3. Test Instruments

Equipment	Manufacturer	Model Number	Serial Number	Cal. Date	Remark
Spectrum Analyzer	Agilent	E4445A	MY46181986	05/16/2011	(2)
Test Site	ATL	TE02	TE02	N.C.R.	-----

Remark: (1) Calibration period 1 year. (2) Calibration period 2 years.

NOTE: N.C.R. = No Calibration Request.

7.4. Test Procedure

The RF output port of the Equipment-Under-Test is directly coupled to the input of the EMC analyzer through a specialized RF connector and a 10dB passive attenuator. A fully charged battery was used for the supply voltage. The Bluetooth frequency hopping function of the EUT was enabled. The spectrum analyzer used the following settings:

1. Span = approx. 2 to 3 times the 20dB bandwidth, centered on a hopping frequency
2. RBW \geq 1% of the 20dB span
3. VBW \geq RBW
4. Sweep = auto
5. Detector function = peak
6. Trace = max hold

The trace was allowed to stabilize. The EUT was transmitting at its maximum data rate. The marker-to-peak function was used to set the marker to the peak of the emission. The marker-delta function was used to measure 20dB down one side of the emission. The marker-delta function and marker was moved to the other side of the emission until it was even with the reference marker. The marker-delta reading at this point was the 20dB bandwidth of the emission.

7.5. Test Result

Model Number	PG76200		
Test Item	Minimum 20dB RF Bandwidth		
Test Mode	Mode 3: GFSK Link Mode		
Date of Test	06/21/2011	Test Site	TE02
Frequency (MHz)	Measurement (MHz)	Limit (MHz)	
2402	0.944	----	
2441	0.943	----	
2480	0.937	----	

Model Number	PG76200		
Test Item	Minimum 20dB RF Bandwidth		
Test Mode	Mode 4: $\pi/4$ -DQPSK Link Mode		
Date of Test	06/21/2011	Test Site	TE02
Frequency (MHz)	20dB Bandwidth (MHz)	Limit (MHz)	
2402	1.351	----	
2441	1.339	----	
2480	1.339	----	

7.6. Test Graphs

Mode 3: GFSK Link Mode																					
2402	<p>Agilent T Freq/Channel</p> <p>Ref 15.86 dBm Atten 20 dB Mkr2 944 kHz 0.34 dB</p> <p>Center 2.402 000 GHz Span 1.5 MHz</p> <table border="1"> <thead> <tr> <th>Marker</th> <th>Trace</th> <th>Type</th> <th>X Axis</th> <th>Amplitude</th> </tr> </thead> <tbody> <tr> <td>1</td> <td>(1)</td> <td>Freq</td> <td>2.402 031 GHz</td> <td>-7.29 dBm</td> </tr> <tr> <td>2R</td> <td>(1)</td> <td>Freq</td> <td>2.401 502 GHz</td> <td>-27.97 dBm</td> </tr> <tr> <td>2a</td> <td>(1)</td> <td>Freq</td> <td>944 kHz</td> <td>0.34 dB</td> </tr> </tbody> </table> <p>Copyright 2000-2005 Agilent Technologies</p>	Marker	Trace	Type	X Axis	Amplitude	1	(1)	Freq	2.402 031 GHz	-7.29 dBm	2R	(1)	Freq	2.401 502 GHz	-27.97 dBm	2a	(1)	Freq	944 kHz	0.34 dB
Marker	Trace	Type	X Axis	Amplitude																	
1	(1)	Freq	2.402 031 GHz	-7.29 dBm																	
2R	(1)	Freq	2.401 502 GHz	-27.97 dBm																	
2a	(1)	Freq	944 kHz	0.34 dB																	
2441	<p>Agilent T Freq/Channel</p> <p>Ref 15.86 dBm Atten 20 dB Mkr2 943 kHz -0.17 dB</p> <p>Center 2.441 000 GHz Span 1.5 MHz</p> <table border="1"> <thead> <tr> <th>Marker</th> <th>Trace</th> <th>Type</th> <th>X Axis</th> <th>Amplitude</th> </tr> </thead> <tbody> <tr> <td>1</td> <td>(1)</td> <td>Freq</td> <td>2.441 033 GHz</td> <td>-6.26 dBm</td> </tr> <tr> <td>2R</td> <td>(1)</td> <td>Freq</td> <td>2.440 507 GHz</td> <td>-27.03 dBm</td> </tr> <tr> <td>2a</td> <td>(1)</td> <td>Freq</td> <td>943 kHz</td> <td>-0.17 dB</td> </tr> </tbody> </table> <p>Copyright 2000-2005 Agilent Technologies</p>	Marker	Trace	Type	X Axis	Amplitude	1	(1)	Freq	2.441 033 GHz	-6.26 dBm	2R	(1)	Freq	2.440 507 GHz	-27.03 dBm	2a	(1)	Freq	943 kHz	-0.17 dB
Marker	Trace	Type	X Axis	Amplitude																	
1	(1)	Freq	2.441 033 GHz	-6.26 dBm																	
2R	(1)	Freq	2.440 507 GHz	-27.03 dBm																	
2a	(1)	Freq	943 kHz	-0.17 dB																	
2480	<p>Agilent T Freq/Channel</p> <p>Ref 15.86 dBm Atten 20 dB Mkr2 937 kHz -0.19 dB</p> <p>Center 2.480 000 GHz Span 1.5 MHz</p> <table border="1"> <thead> <tr> <th>Marker</th> <th>Trace</th> <th>Type</th> <th>X Axis</th> <th>Amplitude</th> </tr> </thead> <tbody> <tr> <td>1</td> <td>(1)</td> <td>Freq</td> <td>2.480 033 GHz</td> <td>-6.86 dBm</td> </tr> <tr> <td>2R</td> <td>(1)</td> <td>Freq</td> <td>2.479 516 GHz</td> <td>-28.25 dBm</td> </tr> <tr> <td>2a</td> <td>(1)</td> <td>Freq</td> <td>937 kHz</td> <td>-0.19 dB</td> </tr> </tbody> </table> <p>Copyright 2000-2005 Agilent Technologies</p>	Marker	Trace	Type	X Axis	Amplitude	1	(1)	Freq	2.480 033 GHz	-6.86 dBm	2R	(1)	Freq	2.479 516 GHz	-28.25 dBm	2a	(1)	Freq	937 kHz	-0.19 dB
Marker	Trace	Type	X Axis	Amplitude																	
1	(1)	Freq	2.480 033 GHz	-6.86 dBm																	
2R	(1)	Freq	2.479 516 GHz	-28.25 dBm																	
2a	(1)	Freq	937 kHz	-0.19 dB																	

Mode 4: $\pi/4$ -DQPSK Link Mode

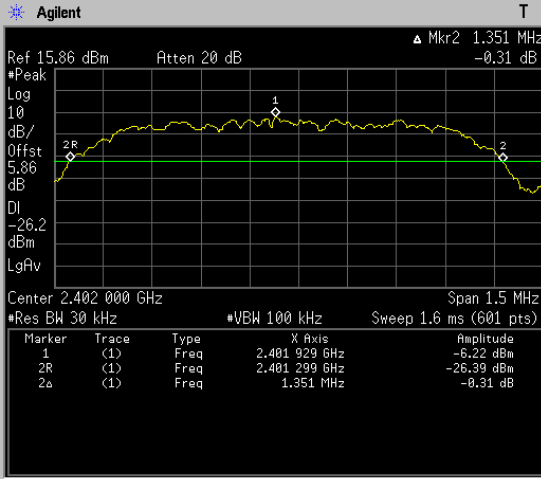
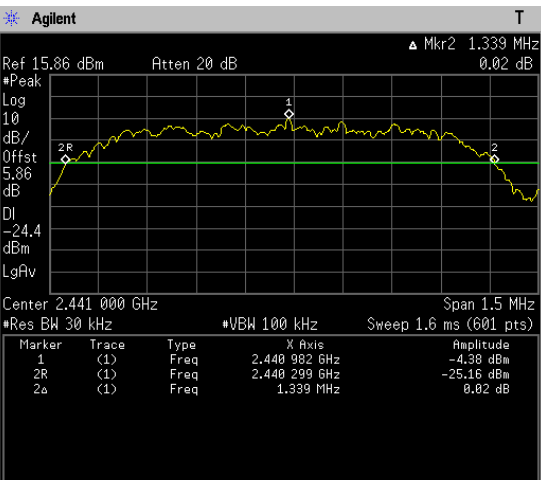
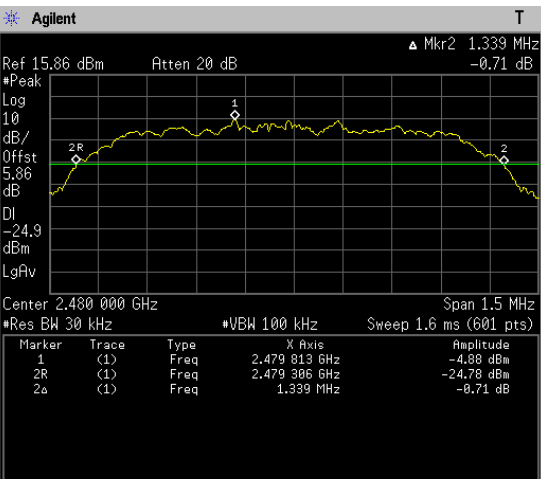
2402	 <p>Agilent T Freq/Channel</p> <p>Ref 15.86 dBm Atten 20 dB Mkr2 1.351 MHz -0.31 dB</p> <p>#Peak</p> <p>Log</p> <p>10 dB/Offst 5.86 dB</p> <p>DI -26.2 dBm</p> <p>LgAv</p> <p>Center 2.402 000 GHz Span 1.5 MHz</p> <p>#Res BW 30 kHz #VBW 100 kHz Sweep 1.6 ms (601 pts)</p> <table border="1"> <thead> <tr> <th>Marker</th> <th>Trace</th> <th>Type</th> <th>X Axis</th> <th>Amplitude</th> </tr> </thead> <tbody> <tr> <td>1</td> <td>(1)</td> <td>Freq</td> <td>2.401 929 GHz</td> <td>-6.22 dBm</td> </tr> <tr> <td>2R</td> <td>(1)</td> <td>Freq</td> <td>2.401 299 GHz</td> <td>-26.39 dBm</td> </tr> <tr> <td>2a</td> <td>(1)</td> <td>Freq</td> <td>1.351 MHz</td> <td>-0.31 dB</td> </tr> </tbody> </table> <p>Copyright 2000-2005 Agilent Technologies</p>	Marker	Trace	Type	X Axis	Amplitude	1	(1)	Freq	2.401 929 GHz	-6.22 dBm	2R	(1)	Freq	2.401 299 GHz	-26.39 dBm	2a	(1)	Freq	1.351 MHz	-0.31 dB
Marker	Trace	Type	X Axis	Amplitude																	
1	(1)	Freq	2.401 929 GHz	-6.22 dBm																	
2R	(1)	Freq	2.401 299 GHz	-26.39 dBm																	
2a	(1)	Freq	1.351 MHz	-0.31 dB																	
2441	 <p>Agilent T Freq/Channel</p> <p>Ref 15.86 dBm Atten 20 dB Mkr2 1.339 MHz 0.02 dB</p> <p>#Peak</p> <p>Log</p> <p>10 dB/Offst 5.86 dB</p> <p>DI -24.4 dBm</p> <p>LgAv</p> <p>Center 2.441 000 GHz Span 1.5 MHz</p> <p>#Res BW 30 kHz #VBW 100 kHz Sweep 1.6 ms (601 pts)</p> <table border="1"> <thead> <tr> <th>Marker</th> <th>Trace</th> <th>Type</th> <th>X Axis</th> <th>Amplitude</th> </tr> </thead> <tbody> <tr> <td>1</td> <td>(1)</td> <td>Freq</td> <td>2.440 982 GHz</td> <td>-4.38 dBm</td> </tr> <tr> <td>2R</td> <td>(1)</td> <td>Freq</td> <td>2.440 299 GHz</td> <td>-25.16 dBm</td> </tr> <tr> <td>2a</td> <td>(1)</td> <td>Freq</td> <td>1.339 MHz</td> <td>0.02 dB</td> </tr> </tbody> </table> <p>Copyright 2000-2005 Agilent Technologies</p>	Marker	Trace	Type	X Axis	Amplitude	1	(1)	Freq	2.440 982 GHz	-4.38 dBm	2R	(1)	Freq	2.440 299 GHz	-25.16 dBm	2a	(1)	Freq	1.339 MHz	0.02 dB
Marker	Trace	Type	X Axis	Amplitude																	
1	(1)	Freq	2.440 982 GHz	-4.38 dBm																	
2R	(1)	Freq	2.440 299 GHz	-25.16 dBm																	
2a	(1)	Freq	1.339 MHz	0.02 dB																	
2480	 <p>Agilent T Freq/Channel</p> <p>Ref 15.86 dBm Atten 20 dB Mkr2 1.339 MHz -0.71 dB</p> <p>#Peak</p> <p>Log</p> <p>10 dB/Offst 5.86 dB</p> <p>DI -24.9 dBm</p> <p>LgAv</p> <p>Center 2.480 000 GHz Span 1.5 MHz</p> <p>#Res BW 30 kHz #VBW 100 kHz Sweep 1.6 ms (601 pts)</p> <table border="1"> <thead> <tr> <th>Marker</th> <th>Trace</th> <th>Type</th> <th>X Axis</th> <th>Amplitude</th> </tr> </thead> <tbody> <tr> <td>1</td> <td>(1)</td> <td>Freq</td> <td>2.479 813 GHz</td> <td>-4.88 dBm</td> </tr> <tr> <td>2R</td> <td>(1)</td> <td>Freq</td> <td>2.479 306 GHz</td> <td>-24.78 dBm</td> </tr> <tr> <td>2a</td> <td>(1)</td> <td>Freq</td> <td>1.339 MHz</td> <td>-0.71 dB</td> </tr> </tbody> </table> <p>Copyright 2000-2005 Agilent Technologies</p>	Marker	Trace	Type	X Axis	Amplitude	1	(1)	Freq	2.479 813 GHz	-4.88 dBm	2R	(1)	Freq	2.479 306 GHz	-24.78 dBm	2a	(1)	Freq	1.339 MHz	-0.71 dB
Marker	Trace	Type	X Axis	Amplitude																	
1	(1)	Freq	2.479 813 GHz	-4.88 dBm																	
2R	(1)	Freq	2.479 306 GHz	-24.78 dBm																	
2a	(1)	Freq	1.339 MHz	-0.71 dB																	

8 Carrier Frequency Separation Measurement

8.1. Limit

Title 47 of the CFR, Part 15 Subpart (c) 15.247(a)(1)(i) requires the measurement of the bandwidth of the transmission between the -20 dB points on the transmitted spectrum. The results of this test determine the limits for channel spacing. The channel spacing shall be a minimum of 25 kHz or the 20 dB bandwidth.

8.2. Test Setup

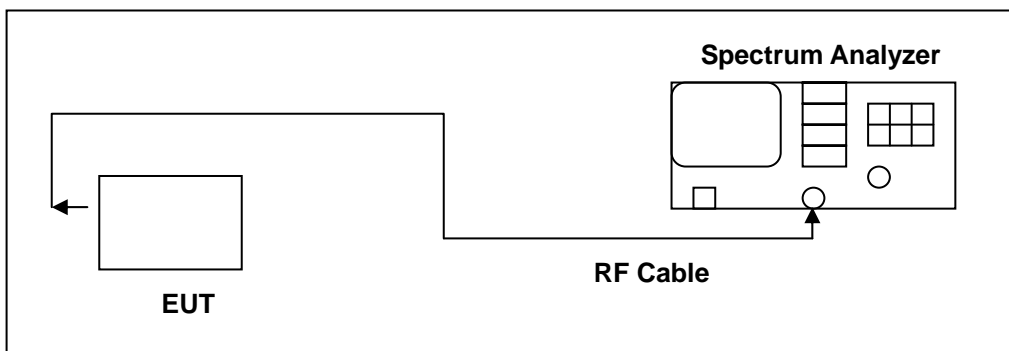

8.3. Test Instruments

Equipment	Manufacturer	Model Number	Serial Number	Cal. Date	Remark
Spectrum Analyzer	Agilent	E4445A	MY46181986	05/16/2011	(2)
Test Site	ATL	TE02	TE02	N.C.R.	-----

Remark: (1) Calibration period 1 year. (2) Calibration period 2 years.

NOTE: N.C.R. = No Calibration Request.

8.4. Test Procedure

The RF output port of the Equipment-Under-Test is directly coupled to the input of the EMC analyzer through a specialized RF connector and a 10dB passive attenuator. A fully charged battery was used for the supply voltage. The Bluetooth transmitter of the V6 had its hopping function enabled. The following spectrum analyzer settings were used:

1. Span = wide enough to capture the peaks of two adjacent channels
2. Resolution (or IF) Bandwidth (RBW) \geq 1% of the span
3. Video (or Average) Bandwidth (VBW) \geq RBW
4. Sweep = auto
5. Detector function = peak
6. Trace = max hold

The trace was allowed to stabilize. The marker-delta function was used to determine the separation between the peaks of the adjacent channels.

8.5. Test Result

Model Number	PG76200		
Test Item	Carrier Frequency Separation		
Test Mode	Mode 3: GFSK Link Mode		
Date of Test	06/21/2011	Test Site	TE02
Frequency (MHz)	Measurement (MHz)	Limit (MHz)	
2441	1	> 0.629	

Model Number	PG76200		
Test Item	Carrier Frequency Separation		
Test Mode	Mode 4: $\pi/4$ -DQPSK Link Mode		
Date of Test	06/21/2011	Test Site	TE02
Frequency (MHz)	Measurement (MHz)	Limit (MHz)	
2441	1	> 0.901	

8.6. Test Graphs

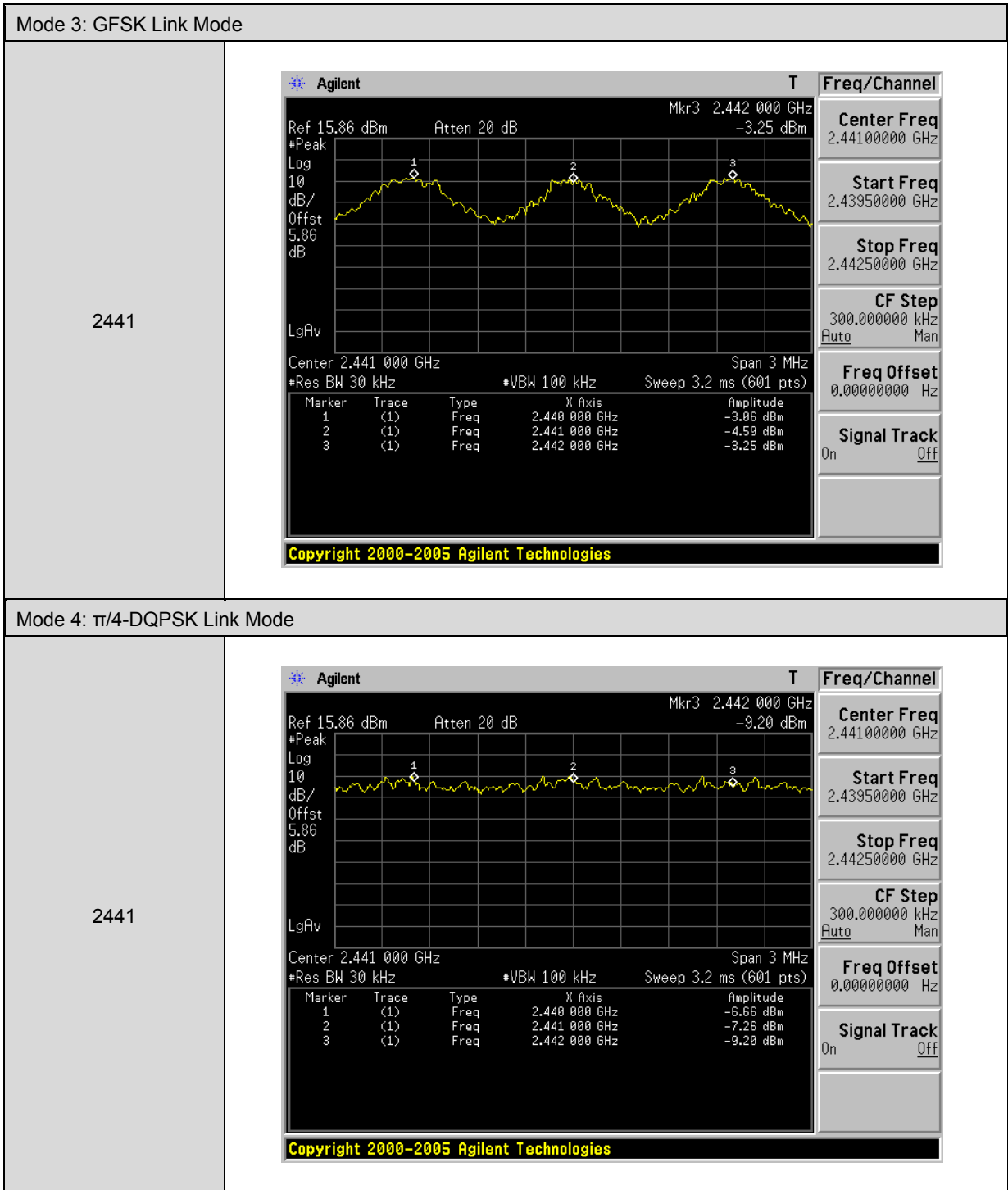

9 Number of Hopping Measurement

9.1. Limit

Frequency hopping systems in the 2400–2483.5 MHz band shall use at least 15 channels.

9.2. Test Setup

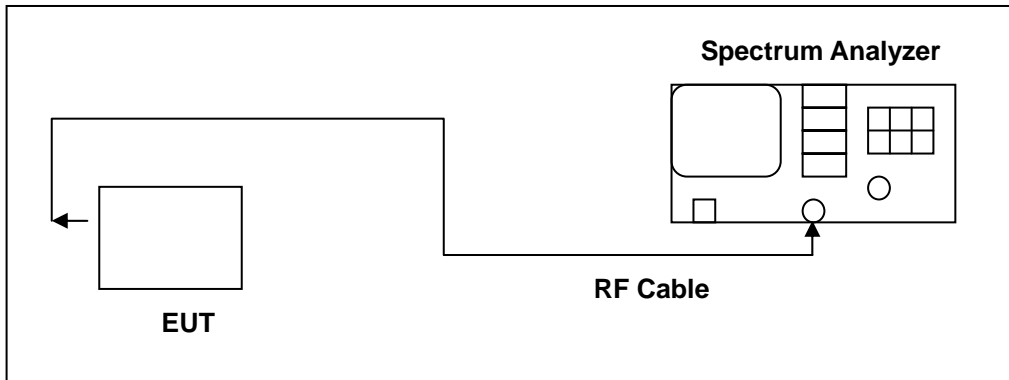

9.3. Test Instruments

Equipment	Manufacturer	Model Number	Serial Number	Cal. Date	Remark
Spectrum Analyzer	Agilent	E4445A	MY46181986	05/16/2011	(2)
Test Site	ATL	TE02	TE02	N.C.R.	-----

Remark: (1) Calibration period 1 year. (2) Calibration period 2 years.

NOTE: N.C.R. = No Calibration Request.

9.4. Test Procedure

The RF output port of the Equipment-Under-Test is directly coupled to the input of the EMC analyzer through a specialized RF connector and a 10dB passive attenuator. A fully charged battery was used for the supply voltage. The Bluetooth frequency hopping function of the EUT was enabled. The spectrum analyzer used the following settings:

1. Span = the frequency band of operation
2. RBW \geq 1% of the span
3. VBW \geq RBW
4. Sweep = auto
5. Detector function = peak
6. Trace = max hold

The trace was allowed to stabilize.

9.5. Test Result

Model Number	PG76200		
Test Item	Number of Hopping		
Test Mode	Mode 3: GFSK Link Mode		
Date of Test	06/21/2011	Test Site	TE02
Frequency Range (MHz)	Measurement (ch)		Limit (ch)
2402 - 2480	79		> 15

Model Number	PG76200		
Test Item	Number of Hopping		
Test Mode	Mode 4: $\pi/4$ -DQPSK Link Mode		
Date of Test	06/21/2011	Test Site	TE02
Frequency Range (MHz)	Measurement (ch)		Limit (ch)
2402 - 2480	79		> 15

9.6. Test Graphs

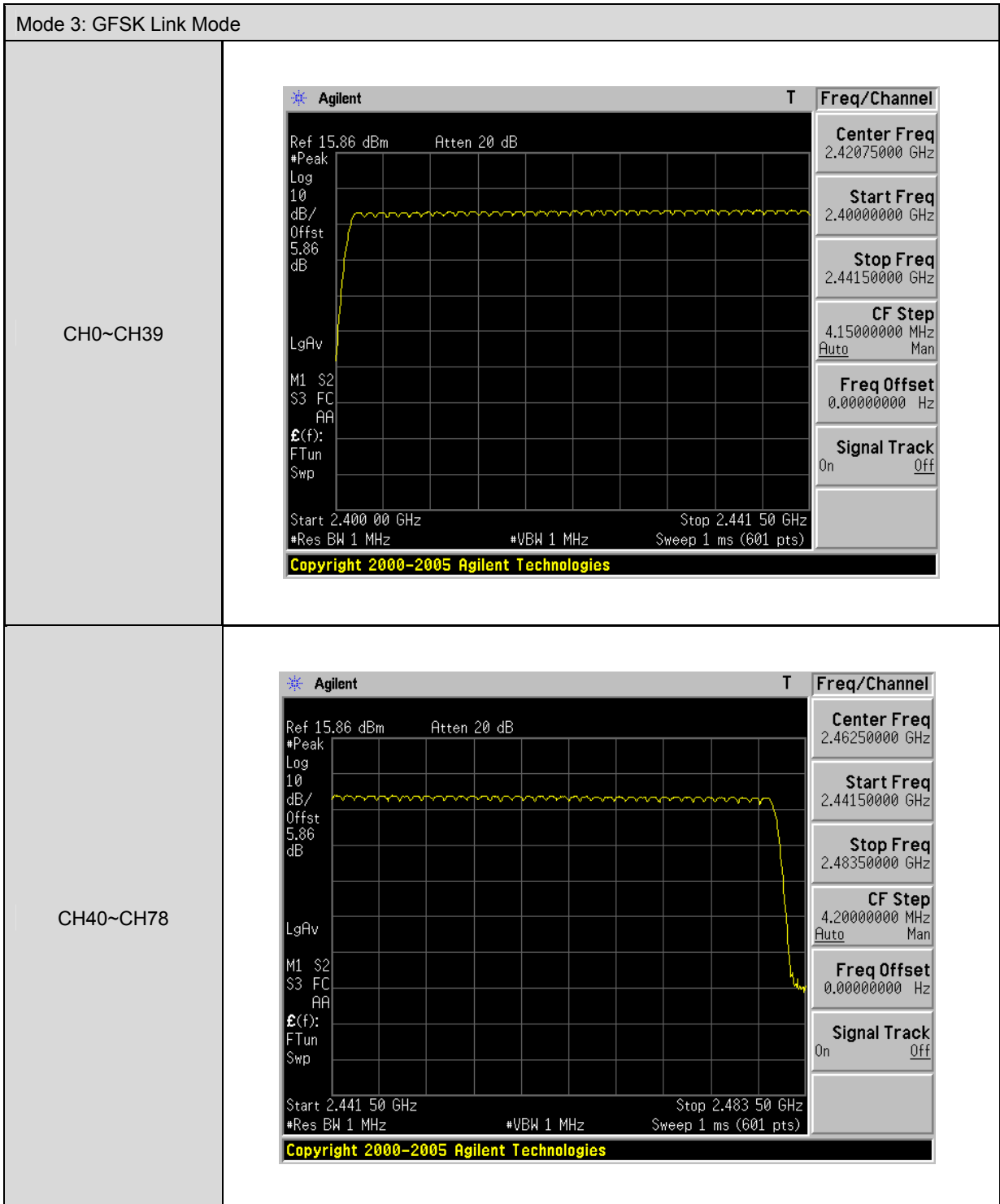

Mode 4: $\pi/4$ -DQPSK Link Mode

CH0~CH39

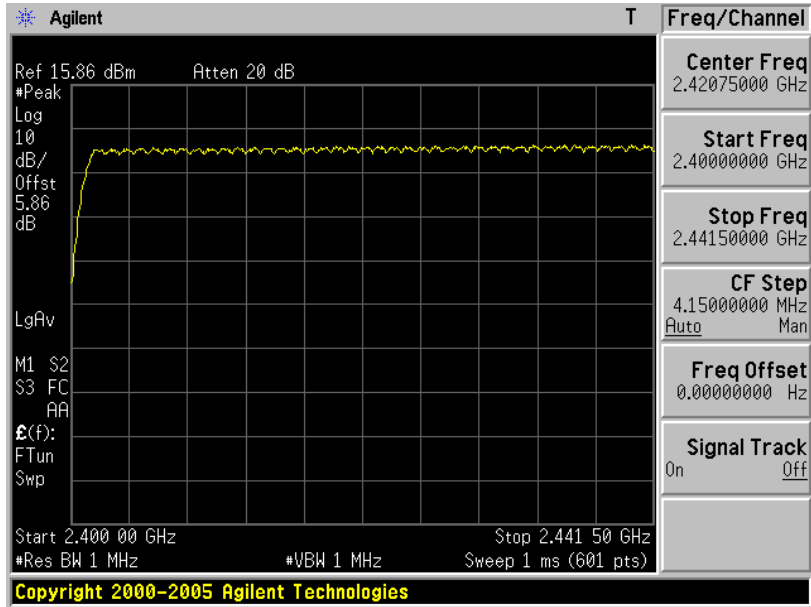

CH40~CH78

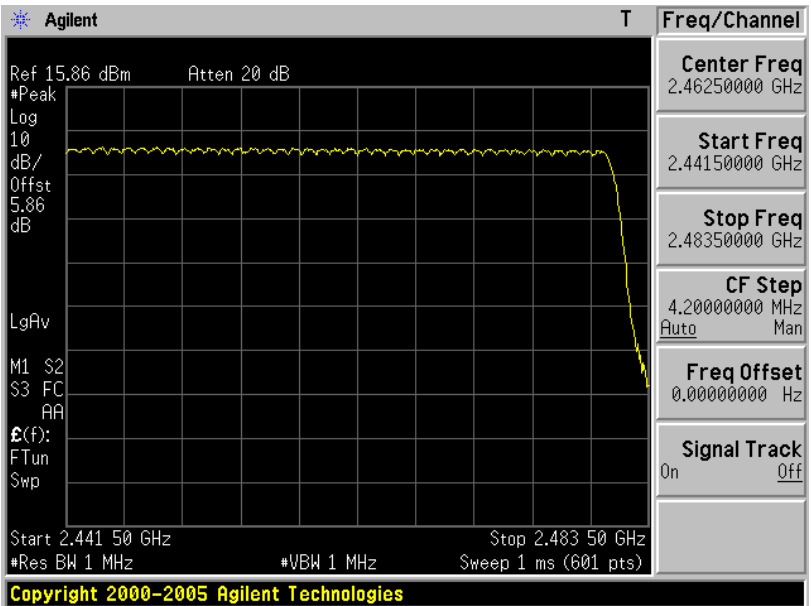

10 Time of Occupancy (Dwell Time) Measurement

10.1.Limit

The average time of occupancy on any channel shall not be greater than 0.4 seconds within a period of 0.4 seconds multiplied by the number of hopping channels employed.

10.2.Test Setup

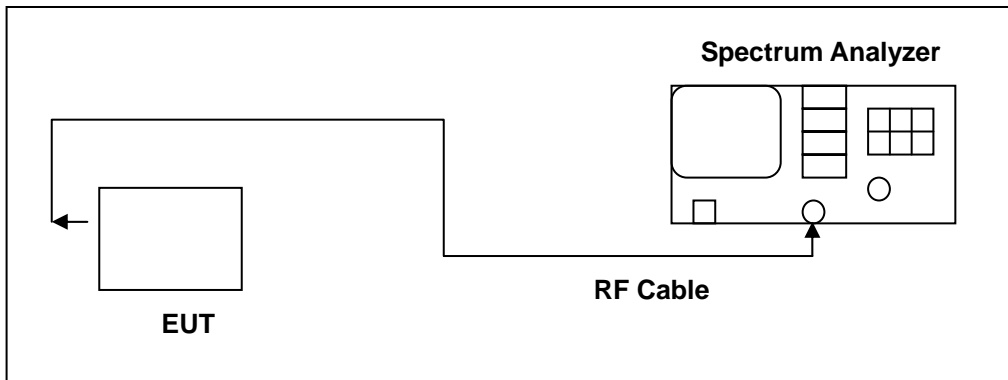

10.3.Test Instruments

Equipment	Manufacturer	Model Number	Serial Number	Cal. Date	Remark
Spectrum Analyzer	Agilent	E4445A	MY46181986	05/16/2011	(2)
Test Site	ATL	TE02	TE02	N.C.R.	-----

Remark: (1) Calibration period 1 year. (2) Calibration period 2 years.

NOTE: N.C.R. = No Calibration Request.

10.4.Test Procedure

The RF output port of the Equipment-Under-Test is directly coupled to the input of the EMC analyzer through a specialized RF connector and a 10dB passive attenuator. A fully charged battery was used for the supply voltage. The Bluetooth hopping function of the EUT was enabled. The following spectrum analyzer settings were used:

1. Span = zero span, centered on a hopping channel
2. RBW = 1 MHz
3. VBW \geq RBW
4. Sweep = as necessary to capture the entire dwell time per hopping channel
5. Detector function = peak
6. Trace = max hold

The marker-delta function was used to determine the dwell time.

10.5.Test Result

Model Number	PG76200		
Test Item	Time of Occupancy (Dwell Time)		
Test Mode	Mode 3: GFSK Link Mode		
Date of Test	06/21/2011	Test Site	TE02
DH1			
Cycle Calculate	79CH * 0.4 = 31.6 (sec)		
The EUT Hopping Number per Sec	1600 times/sec		
Each Channel Dwell Times per Sec	800/79CH = 10.13(times/sec)		
Each Channel Dwell Times (1)	0.550	ms (sec)	
Each Channel Dwell Times on Cycle(2)	31.6 * 10.13 = 320.108(times)		
Dwell Times on Cycle (1) * (2)	176.0594	ms (sec)	
LIMIT(msec)	< = 400		
DH3			
Cycle Calculate	79CH * 0.4 = 31.6 (sec)		
The EUT Hopping Number per Sec	1600 times/sec		
Each Channel Dwell Times per Sec	400/79CH = 5.1(times/sec)		
Each Channel Dwell Times (1)	1.817	ms (sec)	
Each Channel Dwell Times on Cycle(2)	31.6 * 5.1 = 161.16(times)		
Dwell Times on Cycle (1) * (2)	292.8277	ms (sec)	
LIMIT(msec)	< = 400		
DH5			
Cycle Calculate	79CH * 0.4 = 31.6 (sec)		
The EUT Hopping Number per Sec	1600 times/sec		
Each Channel Dwell Times per Sec	266.7/79CH = 3.37(times/sec)		
Each Channel Dwell Times (1)	3.083	ms (sec)	
Each Channel Dwell Times on Cycle(2)	31.6 * 3.37 = 106.492(times)		
Dwell Times on Cycle (1) * (2)	328.3148	ms (sec)	
LIMIT(msec)	< = 400		

Model Number	PG76200		
Test Item	Time of Occupancy (Dwell Time)		
Test Mode	Mode 4: $\pi/4$ -DQPSK Link Mode		
Date of Test	06/21/2011	Test Site	TE02
2DH1			
Cycle Calculate	$79\text{CH} * 0.4 = 31.6 \text{ (sec)}$		
The EUT Hopping Number per Sec	1600 times/sec		
Each Channel Dwell Times per Sec	$800/79\text{CH} = 10.13(\text{times/sec})$		
Each Channel Dwell Times (1)	0.5833	ms (sec)	
Each Channel Dwell Times on Cycle(2)	$31.6 * 10.13 = 320.108(\text{times})$		
Dwell Times on Cycle (1) * (2)	186.7190	ms (sec)	
LIMIT(msec)	< = 400		
2DH3			
Cycle Calculate	$79\text{CH} * 0.4 = 31.6 \text{ (sec)}$		
The EUT Hopping Number per Sec	1600 times/sec		
Each Channel Dwell Times per Sec	$400/79\text{CH} = 5.1(\text{times/sec})$		
Each Channel Dwell Times (1)	1.833	ms (sec)	
Each Channel Dwell Times on Cycle(2)	$31.6 * 5.1 = 161.16(\text{times})$		
Dwell Times on Cycle (1) * (2)	295.4063	ms (sec)	
LIMIT(msec)	< = 400		
2DH5			
Cycle Calculate	$79\text{CH} * 0.4 = 31.6 \text{ (sec)}$		
The EUT Hopping Number per Sec	1600 times/sec		
Each Channel Dwell Times per Sec	$266.7/79\text{CH} = 3.37(\text{times/sec})$		
Each Channel Dwell Times (1)	3.033	ms (sec)	
Each Channel Dwell Times on Cycle(2)	$31.6 * 3.37 = 106.492(\text{times})$		
Dwell Times on Cycle (1) * (2)	322.9902	ms (sec)	
LIMIT(msec)	< = 400		

10.6. Test Graphs

Mode 3: GFSK Link Mode	
DH1	<p>Agilent R T Freq/Channel Ref 15.86 dBm Atten 20 dB Δ Mkr1 550 µs -1.34 dB #Peak Log 10 dB/ Offst 5.86 dB LgAv W1 S2 S3 FS AA E(f): FTun Center 2.402 000 GHz Span 0 Hz Res BW 1 MHz VBW 1 MHz Sweep 10 ms (601 pts) Copyright 2000-2005 Agilent Technologies</p>
DH3	<p>Agilent T Freq/Channel Ref 15.86 dBm Atten 20 dB Δ Mkr1 1.817 ms -1.48 dB #Peak Log 10 dB/ Offst 5.86 dB LgAv W1 S2 S3 FS AA E(f): FTun Center 2.402 000 GHz Span 0 Hz Res BW 1 MHz VBW 1 MHz Sweep 10 ms (601 pts) Copyright 2000-2005 Agilent Technologies</p>
DH5	<p>Agilent T Freq/Channel Ref 15.86 dBm Atten 20 dB Δ Mkr1 3.083 ms 2.39 dB #Peak Log 10 dB/ Offst 5.86 dB LgAv W1 S2 S3 FS AA E(f): FTun Center 2.402 000 GHz Span 0 Hz Res BW 1 MHz VBW 1 MHz Sweep 10 ms (601 pts) Copyright 2000-2005 Agilent Technologies</p>

Mode 4: $\pi/4$ -DQPSK Link Mode

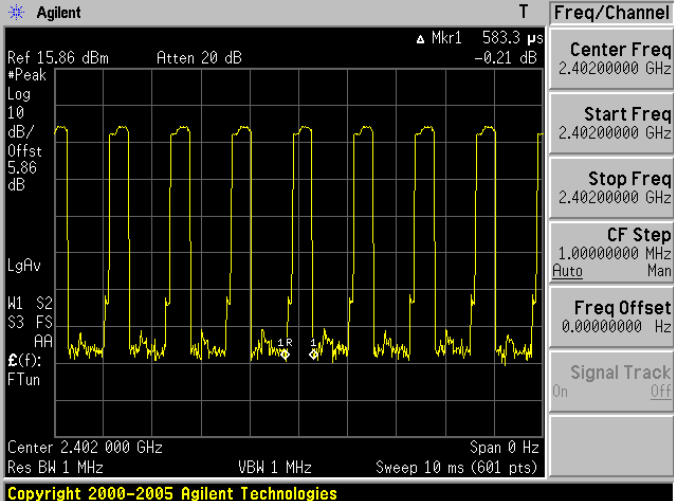
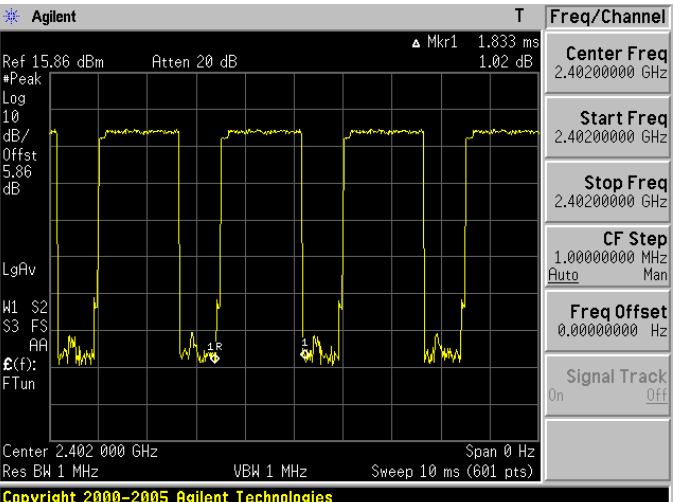
<p>2DH1</p>	 <p>Agilent T Freq/Channel Ref 15.86 dBm Atten 20 dB Δ Mkr1 583.3 μs -0.21 dB #Peak Log 10 dB/ Offst 5.86 dB LgAv W1 S2 S3 FS AA $\mathcal{E}(f)$: FTun Center 2.402 000 GHz Span 0 Hz Res BW 1 MHz VBW 1 MHz Sweep 10 ms (601 pts) Copyright 2000-2005 Agilent Technologies</p> <p>Center Freq 2.40200000 GHz Start Freq 2.40200000 GHz Stop Freq 2.40200000 GHz CF Step 1.00000000 MHz Auto Man Freq Offset 0.00000000 Hz Signal Track On Off</p>
<p>2DH3</p>	 <p>Agilent T Freq/Channel Ref 15.86 dBm Atten 20 dB Δ Mkr1 1.833 ms 1.02 dB #Peak Log 10 dB/ Offst 5.86 dB LgAv W1 S2 S3 FS AA $\mathcal{E}(f)$: FTun Center 2.402 000 GHz Span 0 Hz Res BW 1 MHz VBW 1 MHz Sweep 10 ms (601 pts) Copyright 2000-2005 Agilent Technologies</p> <p>Center Freq 2.40200000 GHz Start Freq 2.40200000 GHz Stop Freq 2.40200000 GHz CF Step 1.00000000 MHz Auto Man Freq Offset 0.00000000 Hz Signal Track On Off</p>
<p>2DH5</p>	 <p>Agilent T Freq/Channel Ref 15.86 dBm Atten 20 dB Δ Mkr1 3.033 ms -0.39 dB #Peak Log 10 dB/ Offst 5.86 dB LgAv W1 S2 S3 FS AA $\mathcal{E}(f)$: FTun Center 2.402 000 GHz Span 0 Hz Res BW 1 MHz VBW 1 MHz Sweep 10 ms (601 pts) Copyright 2000-2005 Agilent Technologies</p> <p>Center Freq 2.40200000 GHz Start Freq 2.40200000 GHz Stop Freq 2.40200000 GHz CF Step 1.00000000 MHz Auto Man Freq Offset 0.00000000 Hz Signal Track On Off</p>

11 Out of Band Conducted Emissions Measurement

11.1.Limit

In any 100 kHz bandwidth outside the frequency band in which the spread spectrum or digitally modulated intentional radiator is operating, the radio frequency power that is produced by the intentional radiator shall be at least 20 dB below that in the 100 kHz bandwidth within the band that contains the highest level of the desired power

11.2.Test Setup

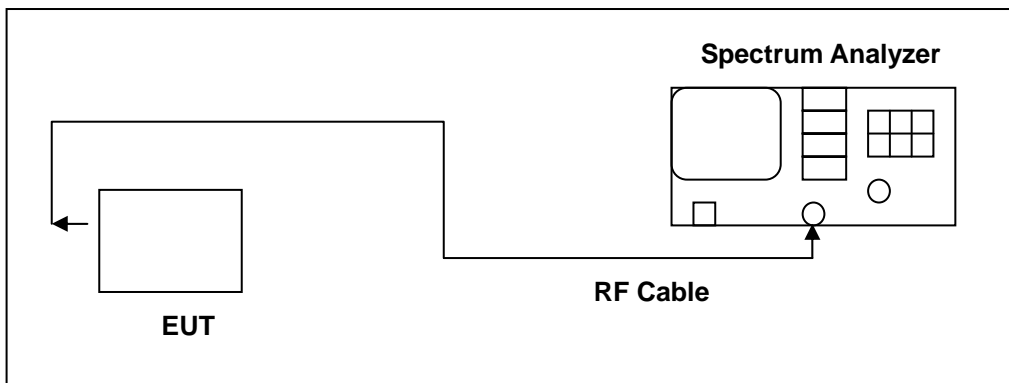

11.3.Test Instruments

Equipment	Manufacturer	Model Number	Serial Number	Cal. Date	Remark
Spectrum Analyzer	Agilent	E4445A	MY46181986	05/16/2011	(2)
Test Site	ATL	TE02	TE02	N.C.R.	-----

Remark: (1) Calibration period 1 year. (2) Calibration period 2 years.

NOTE: N.C.R. = No Calibration Request.

11.4.Test Procedure

In any 100 kHz bandwidth outside the EUT pass band, the RF power produced by the modulation products of the spreading sequence, the information sequence, and the carrier frequency shall be at least 20 dB below that of the maximum in-band 100 kHz emission, antenna output of the EUT was coupled directly to spectrum analyzer; if an external attenuator and/or cable was used, these losses are compensated for with the analyzer OFFSET function.

All other types of emissions from the EUT shall meet the general limits for radiated frequencies outside the pass band. The test was performed at 3 channels (Channel 0, 39, 78)

11.5. Test Graphs

Mode 3: GFSK Link Mode	
2402	<p>Agilent 11:53:00 Jun 21, 2011 R T</p> <p>Ref 15.86 dBm Atten 20 dB Mkr1 2.40 GHz -1.942 dBm</p> <p>Peak Log 10 dB/ Offset 5.86 dB DI -21.9 dBm</p> <p>V1 S2 S3 FC AA</p> <p>Center 13.27 GHz Span 26.47 GHz #Res BW 100 kHz #VBW 100 kHz Sweep 3.41 s (401 pts)</p> <p>Freq/Channel: Center Freq 13.2650000 GHz, Start Freq 30.0000000 MHz, Stop Freq 26.5000000 GHz, CF Step 2.64700000 GHz Auto Man, Freq Offset 0.00000000 Hz, Signal Track On Off</p>
2441	<p>Agilent 11:53:42 Jun 21, 2011 R T</p> <p>Ref 15.86 dBm Atten 20 dB Mkr1 2.44 GHz 0.414 dBm</p> <p>Peak Log 10 dB/ Offset 5.86 dB DI -20.4 dBm</p> <p>V1 S2 S3 FC AA</p> <p>Center 13.27 GHz Span 26.47 GHz #Res BW 100 kHz #VBW 100 kHz Sweep 3.41 s (401 pts)</p> <p>Freq/Channel: Center Freq 13.2650000 GHz, Start Freq 30.0000000 MHz, Stop Freq 26.5000000 GHz, CF Step 2.64700000 GHz Auto Man, Freq Offset 0.00000000 Hz, Signal Track On Off</p>
2480	<p>Agilent 11:54:18 Jun 21, 2011 R T</p> <p>Ref 15.86 dBm Atten 20 dB Mkr1 2.48 GHz -0.883 dBm</p> <p>Peak Log 10 dB/ Offset 5.86 dB DI -20.9 dBm</p> <p>V1 S2 S3 FC AA</p> <p>Center 13.27 GHz Span 26.47 GHz #Res BW 100 kHz #VBW 100 kHz Sweep 3.41 s (401 pts)</p> <p>Freq/Channel: Center Freq 13.2650000 GHz, Start Freq 30.0000000 MHz, Stop Freq 26.5000000 GHz, CF Step 2.64700000 GHz Auto Man, Freq Offset 0.00000000 Hz, Signal Track On Off</p>

Mode 4: $\pi/4$ -DQPSK Link Mode

<p>2402</p>	<p>Agilent 11:55:36 Jun 21, 2011 R T</p> <p>Ref 15.86 dBm Atten 20 dB Mkr1 2.40 GHz -2.182 dBm</p> <p>Peak Log 10 dB/Offset 5.86 dB DI -22.2 dBm</p> <p>V1 S2 S3 FC AA</p> <p>Center 13.27 GHz Span 26.47 GHz #Res BW 100 kHz #VBW 100 kHz Sweep 3.41 s (401 pts)</p> <p>Freq/Channel: Center Freq 13.2650000 GHz, Start Freq 30.0000000 MHz, Stop Freq 26.5000000 GHz, CF Step 2.64700000 GHz, Freq Offset 0.00000000 Hz, Signal Track Off</p>
<p>2441</p>	<p>Agilent 11:56:12 Jun 21, 2011 R T</p> <p>Ref 15.86 dBm Atten 20 dB Mkr1 2.44 GHz -0.878 dBm</p> <p>Peak Log 10 dB/Offset 5.86 dB DI -20.9 dBm</p> <p>V1 S2 S3 FC AA</p> <p>Start 30 MHz Stop 26.5 GHz #Res BW 100 kHz #VBW 100 kHz Sweep 3.41 s (401 pts)</p> <p>Freq/Channel: Center Freq 13.2650000 GHz, Start Freq 30.0000000 MHz, Stop Freq 26.5000000 GHz, CF Step 2.64700000 GHz, Freq Offset 0.00000000 Hz, Signal Track Off</p>
<p>2480</p>	<p>Agilent 11:57:51 Jun 21, 2011 R T</p> <p>Ref 15.86 dBm Atten 20 dB Mkr1 2.48 GHz -1.153 dBm</p> <p>Peak Log 10 dB/Offset 5.86 dB DI -21.2 dBm</p> <p>V1 S2 S3 FC AA</p> <p>Start 30 MHz Stop 26.5 GHz #Res BW 100 kHz #VBW 100 kHz Sweep 3.41 s (401 pts)</p> <p>Freq/Channel: Center Freq 13.2650000 GHz, Start Freq 30.0000000 MHz, Stop Freq 26.5000000 GHz, CF Step 2.64700000 GHz, Freq Offset 0.00000000 Hz, Signal Track Off</p>

12 Band Edges Measurement

12.1.Limit

In any 100 kHz bandwidth outside the frequency band in which the spread spectrum or digitally modulated intentional radiator is operating, the radio frequency power that is produced by the intentional radiator shall be at least 20 dB below that in the 100 kHz bandwidth within the band that contains the highest level of the desired power

12.2.Test Setup

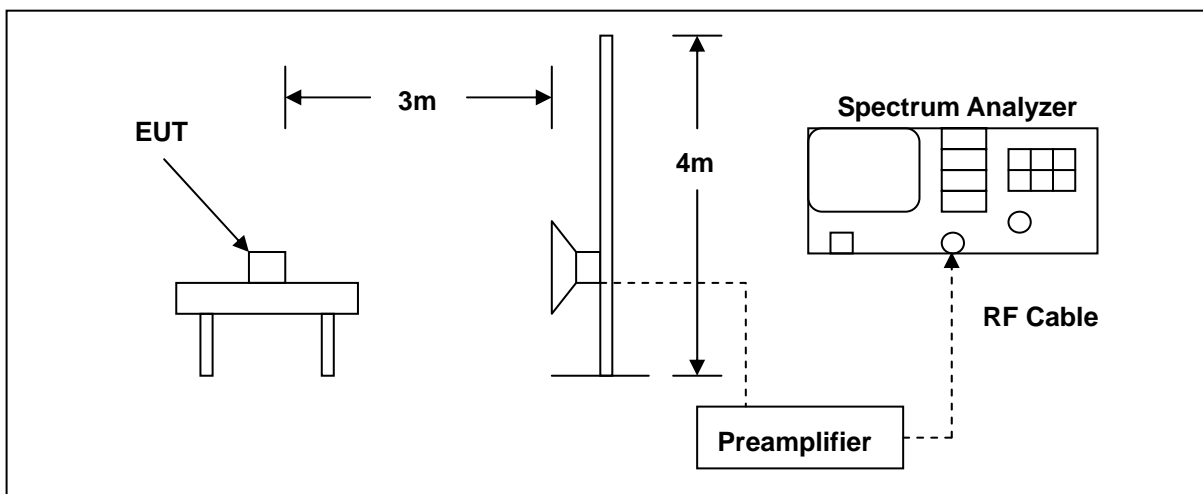

12.3.Test Instruments

Equipment	Manufacturer	Model Number	Serial Number	Cal. Date	Remark
Spectrum Analyzer	Agilent	E4408B	MY45107753	06/24/2010	(1)
Pre Amplifier	Agilent	8449B	3008A02237	02/23/2011	(1)
Horn Antenna	SCHWARZBECK MESS-ELEKTRONIK	9120D	9120D-550	06/29/2010	(1)
Test Site	ATL	TE01	888001	07/30/2010	-----

Remark: (1) Calibration period 1 year. (2) Calibration period 2 years.

NOTE: N.C.R. = No Calibration Request.

12.4. Test Procedure

The emissions on the harmonics frequencies, the limits, and the margin of compliance are presented. These tests were made when the transmitter was in full radiated power. The additional test was performed to show compliance with the requirement at the band-edge frequency 2483.5 MHz and up to 2500 MHz and at 2390.0 MHz.

The transmitter was configured with the worst case antenna and setup to transmit at the highest channel. Then the field strength was measured at 2483.5 MHz.

The transmitter was then configured with the worst case antenna and setup to transmit at the lowest channel. Then the field strength was measured at 2390.0 MHz. These tests were performed at 4 different bit rates.

For measurements the resolution bandwidth is set to 1 MHz, and then the video bandwidth is set to 1 MHz for peak measurements and 10 Hz for average measurements.

12.5.Test Result

Standard:	FCC Part 15C	Test Distance:	3m
Test item:	Radiated Emission	Power:	AC 120V/60Hz
Model Number:	PG76200	Temp.(°C)/Hum.(%RH):	26(°C)/60%RH
Mode:	Mode 3	Date:	06/20/2011
Frequency:	2402 MHz	Test By:	Gary Wu
Ant.Polar.:	Horizontal		

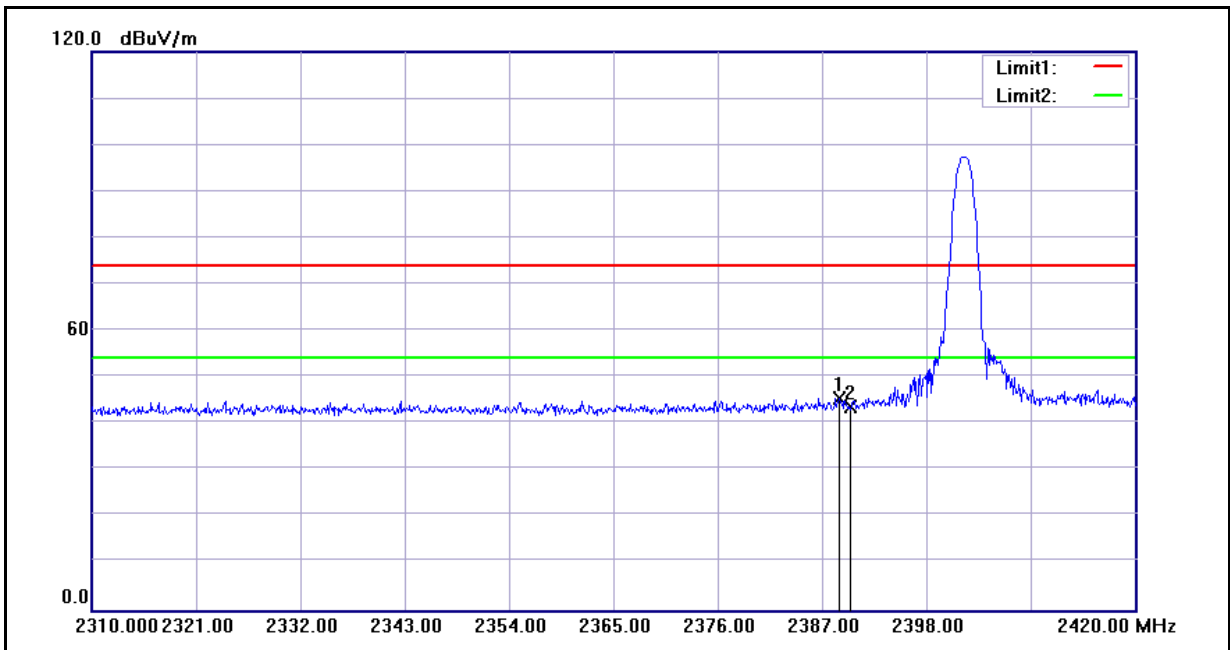

No.	Frequency (MHz)	Reading (dBuV)	Correct Factor(dB/m)	Result (dBuV/m)	Limit (dBuV/m)	Margin (dB)	Remark
1	2388.870	63.37	-17.78	45.59	74.00	-28.41	peak
2	2390.000	61.35	-17.78	43.57	74.00	-30.43	peak

Standard:	FCC Part 15C	Test Distance:	3m
Test item:	Radiated Emission	Power:	AC 120V/60Hz
Model Number:	PG76200	Temp.(°C)/Hum.(%RH):	26(°C)/60%RH
Mode:	Mode 3	Date:	06/20/2011
Frequency:	2402 MHz	Test By:	Gary Wu
Ant.Polar.:	Vertical		

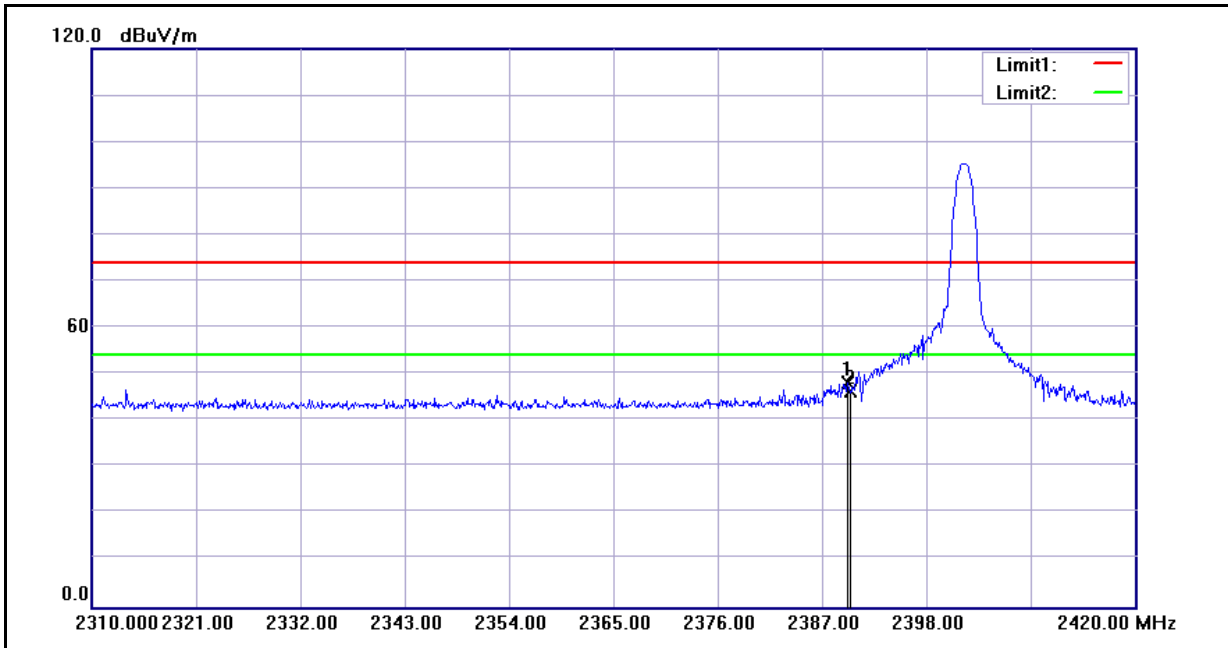

No.	Frequency (MHz)	Reading (dBuV)	Correct Factor(dB/m)	Result (dBuV/m)	Limit (dBuV/m)	Margin (dB)	Remark
1	2389.640	65.82	-17.78	48.04	74.00	-25.96	peak
2	2390.000	64.20	-17.78	46.42	74.00	-27.58	peak

Standard:	FCC Part 15C	Test Distance:	3m
Test item:	Radiated Emission	Power:	AC 120V/60Hz
Model Number:	PG76200	Temp.(°C)/Hum.(%RH):	26(°C)/60%RH
Mode:	Mode 3	Date:	06/20/2011
Frequency:	2480 MHz	Test By:	Gary Wu
Ant.Polar.:	Horizontal		

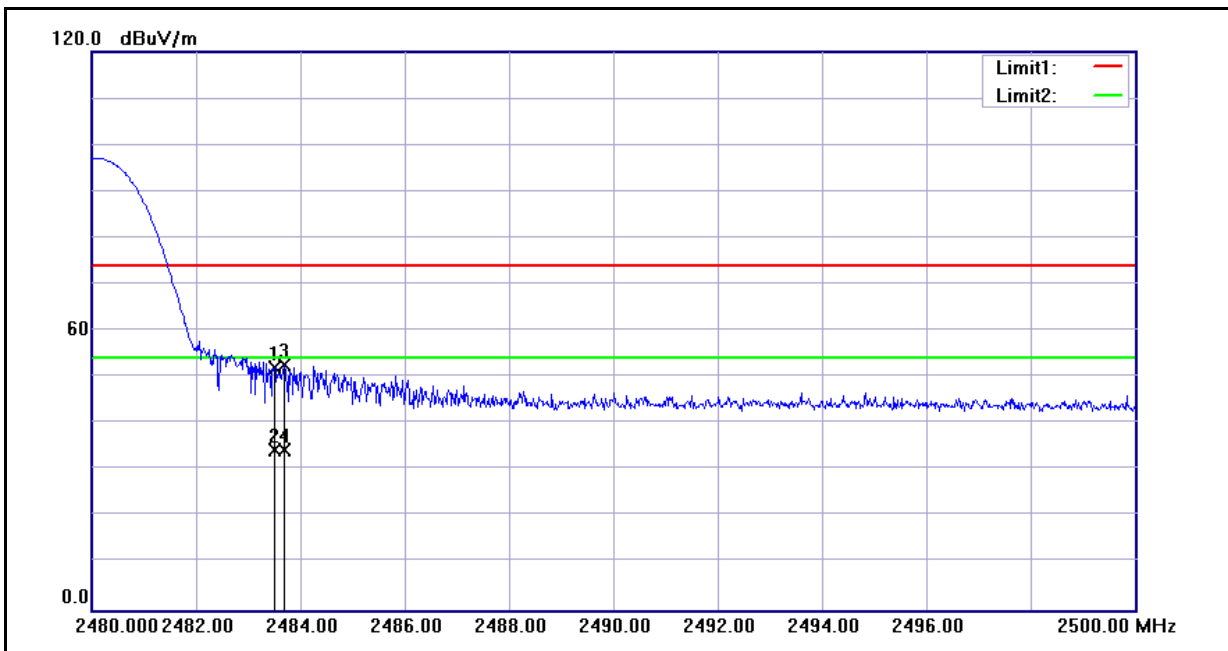

No.	Frequency (MHz)	Reading (dBuV)	Correct Factor(dB/m)	Result (dBuV/m)	Limit (dBuV/m)	Margin (dB)	Remark
1	2483.500	69.78	-17.65	52.13	74.00	-21.87	peak
2	2483.500	51.93	-17.65	34.28	54.00	-19.72	AVG
3	2483.700	70.22	-17.65	52.57	74.00	-21.43	peak
4	2483.700	51.86	-17.65	34.21	54.00	-19.79	AVG

Standard:	FCC Part 15C	Test Distance:	3m
Test item:	Radiated Emission	Power:	AC 120V/60Hz
Model Number:	PG76200	Temp.(°C)/Hum.(%RH):	26(°C)/60%RH
Mode:	Mode 3	Date:	06/20/2011
Frequency:	2480 MHz	Test By:	Gary Wu
Ant.Polar.:	Vertical		

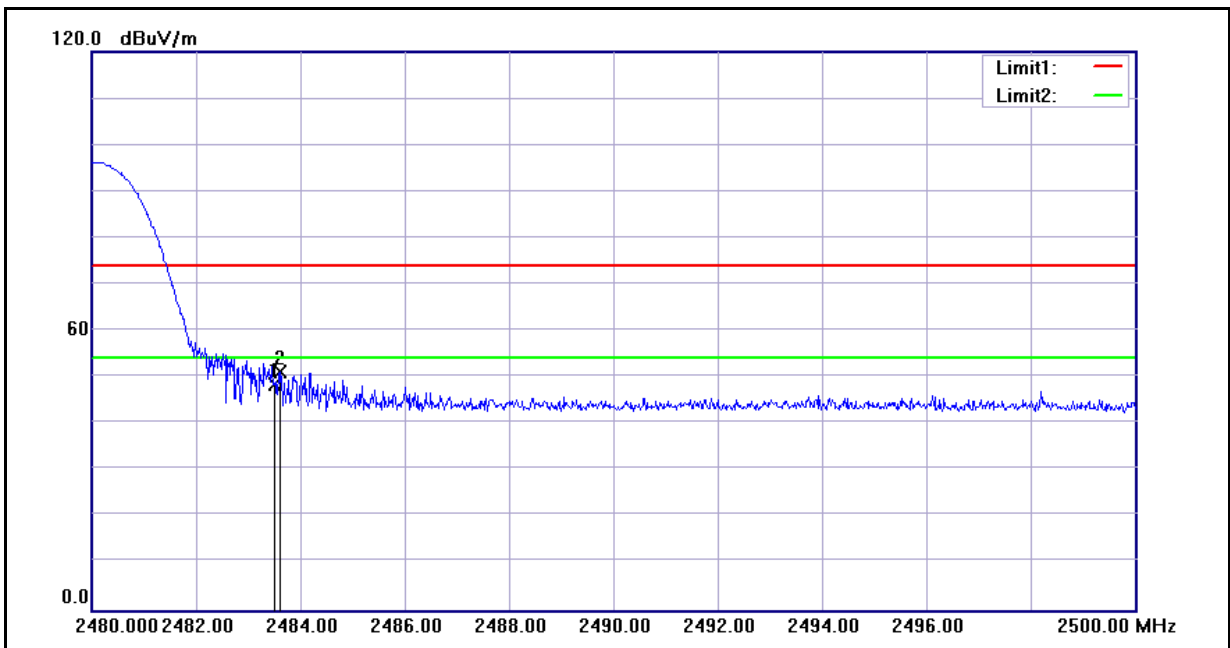

No.	Frequency (MHz)	Reading (dBuV)	Correct Factor(dB/m)	Result (dBuV/m)	Limit (dBuV/m)	Margin (dB)	Remark
1	2483.500	66.12	-17.65	48.47	74.00	-25.53	peak
2	2483.600	68.85	-17.65	51.20	74.00	-22.80	peak

Standard:	FCC Part 15C	Test Distance:	3m
Test item:	Radiated Emission	Power:	AC 120V/60Hz
Model Number:	PG76200	Temp.(°C)/Hum.(%RH):	26(°C)/60%RH
Mode:	Mode 4	Date:	06/20/2011
Frequency:	2402 MHz	Test By:	Gary Wu
Ant.Polar.:	Horizontal		

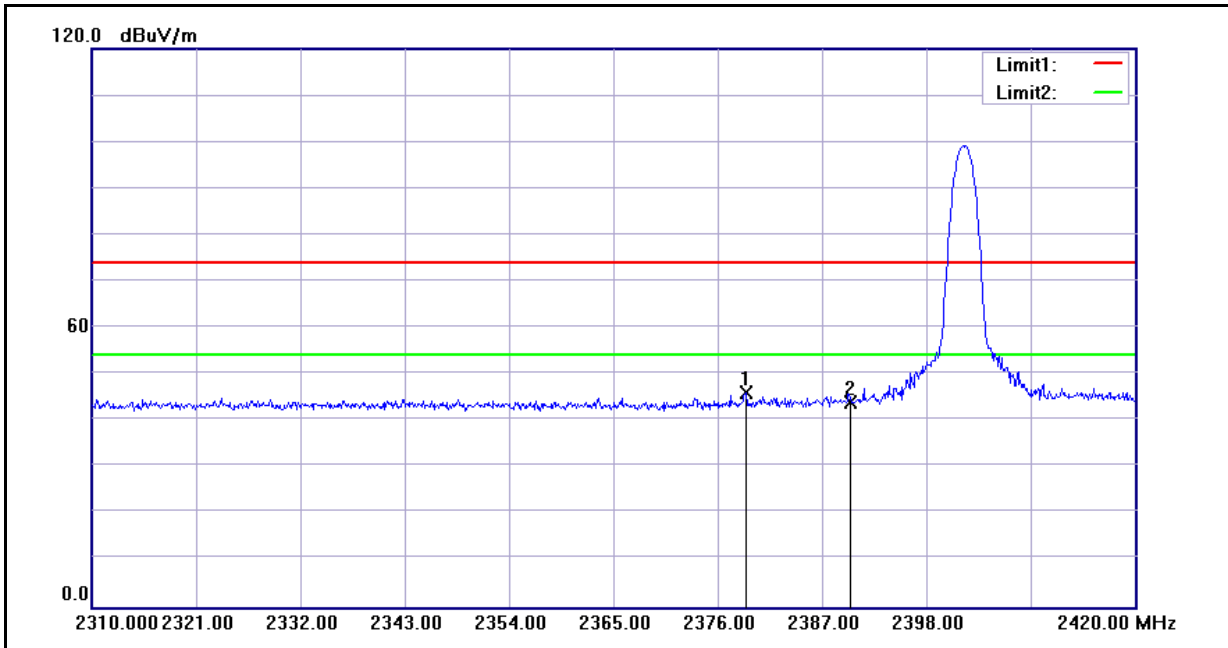

No.	Frequency (MHz)	Reading (dBuV)	Correct Factor(dB/m)	Result (dBuV/m)	Limit (dBuV/m)	Margin (dB)	Remark
1	2378.970	63.94	-17.79	46.15	74.00	-27.85	peak
2	2390.000	61.80	-17.78	44.02	74.00	-29.98	peak

Standard:	FCC Part 15C	Test Distance:	3m
Test item:	Radiated Emission	Power:	AC 120V/60Hz
Model Number:	PG76200	Temp.(°C)/Hum.(%RH):	26(°C)/60%RH
Mode:	Mode 4	Date:	06/20/2011
Frequency:	2402 MHz	Test By:	Gary Wu
Ant.Polar.:	Vertical		

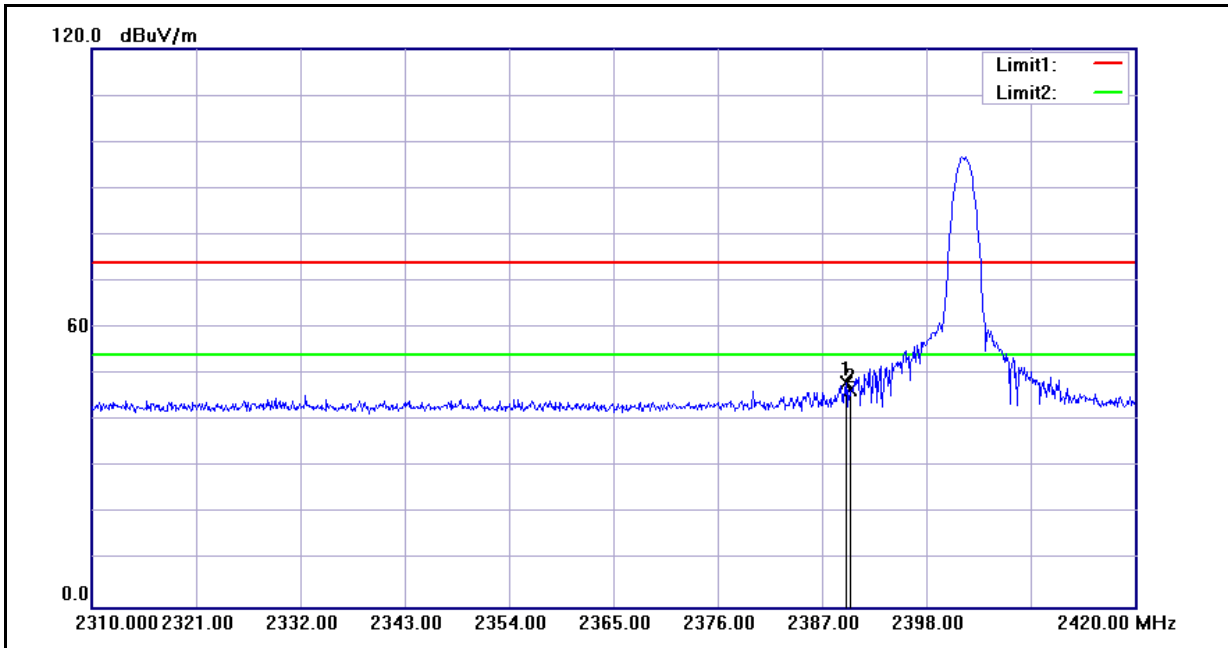

No.	Frequency (MHz)	Reading (dBuV)	Correct Factor(dB/m)	Result (dBuV/m)	Limit (dBuV/m)	Margin (dB)	Remark
1	2389.530	65.90	-17.78	48.12	74.00	-25.88	peak
2	2390.000	64.37	-17.78	46.59	74.00	-27.41	peak

Standard:	FCC Part 15C	Test Distance:	3m
Test item:	Radiated Emission	Power:	AC 120V/60Hz
Model Number:	PG76200	Temp.(°C)/Hum.(%RH):	26(°C)/60%RH
Mode:	Mode 4	Date:	06/20/2011
Frequency:	2480 MHz	Test By:	Gary Wu
Ant.Polar.:	Horizontal		

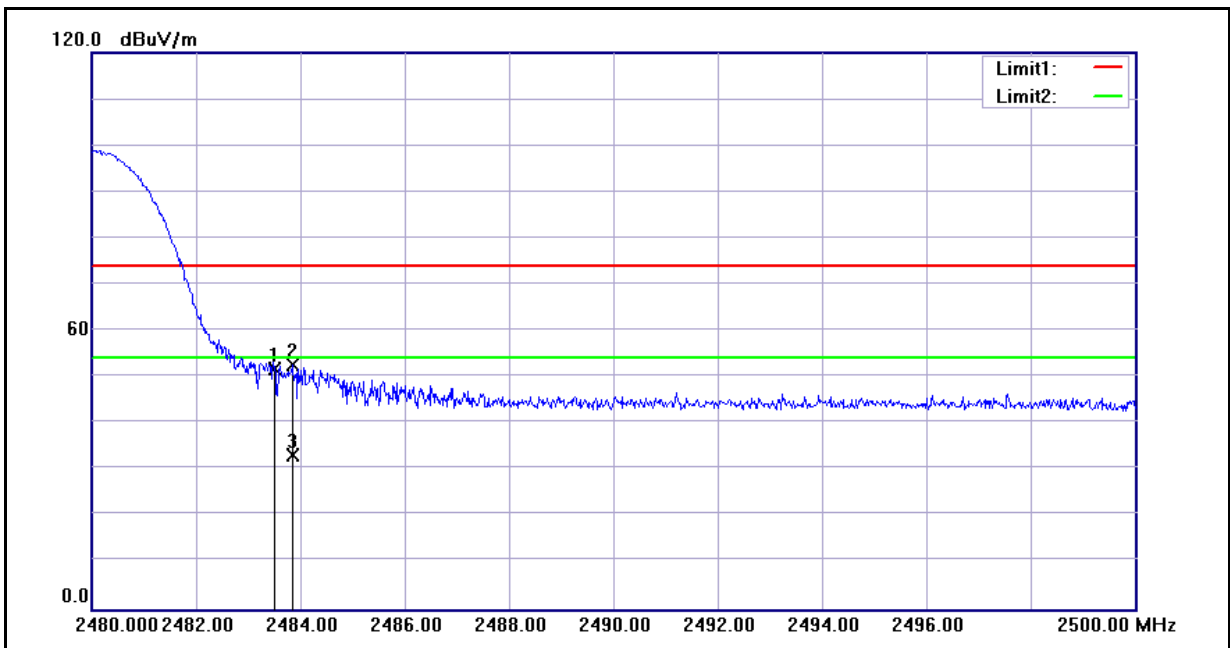

No.	Frequency (MHz)	Reading (dBuV)	Correct Factor(dB/m)	Result (dBuV/m)	Limit (dBuV/m)	Margin (dB)	Remark
1	2483.500	69.30	-17.65	51.65	74.00	-22.35	peak
2	2483.840	70.30	-17.65	52.65	74.00	-21.35	peak
3	2483.840	50.78	-17.65	33.13	54.00	-20.87	AVG

Standard:	FCC Part 15C	Test Distance:	3m
Test item:	Radiated Emission	Power:	AC 120V/60Hz
Model Number:	PG76200	Temp.(°C)/Hum.(%RH):	26(°C)/60%RH
Mode:	Mode 4	Date:	06/20/2011
Frequency:	2480 MHz	Test By:	Gary Wu
Ant.Polar.:	Vertical		

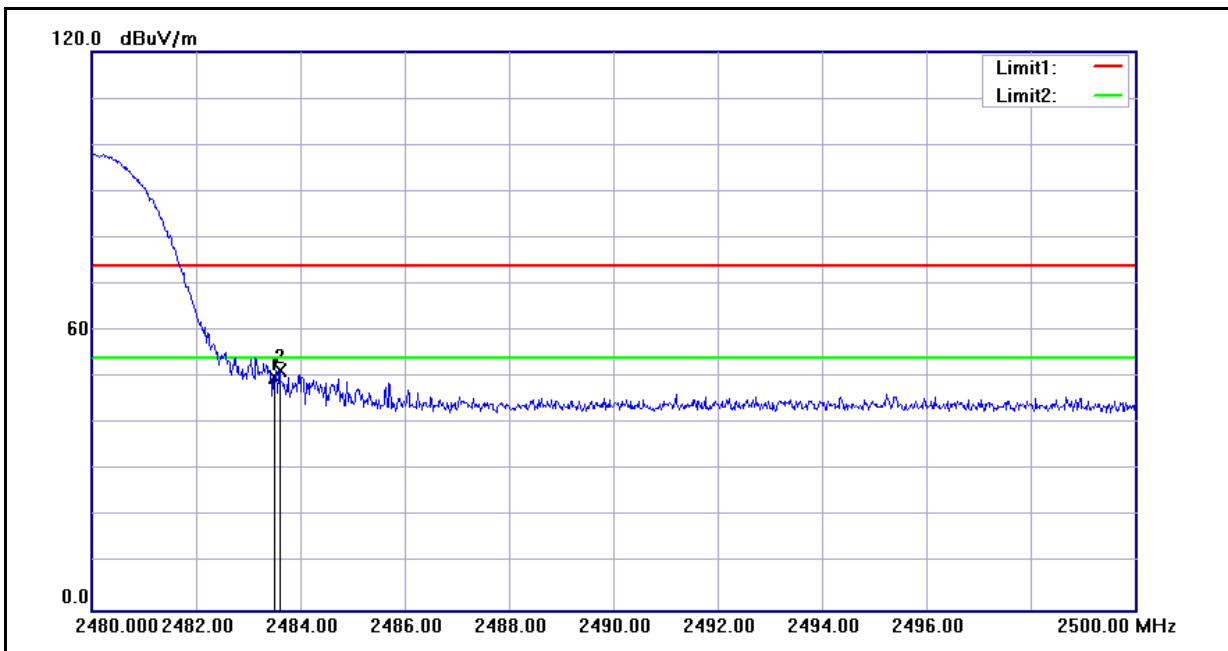

No.	Frequency (MHz)	Reading (dBuV)	Correct Factor(dB/m)	Result (dBuV/m)	Limit (dBuV/m)	Margin (dB)	Remark
1	2483.500	67.46	-17.65	49.81	74.00	-24.19	peak
2	2483.600	69.08	-17.65	51.43	74.00	-22.57	peak

13 99 % Occupied Bandwidth Measurement

13.1.Limit

N/A

13.2.Test Setup

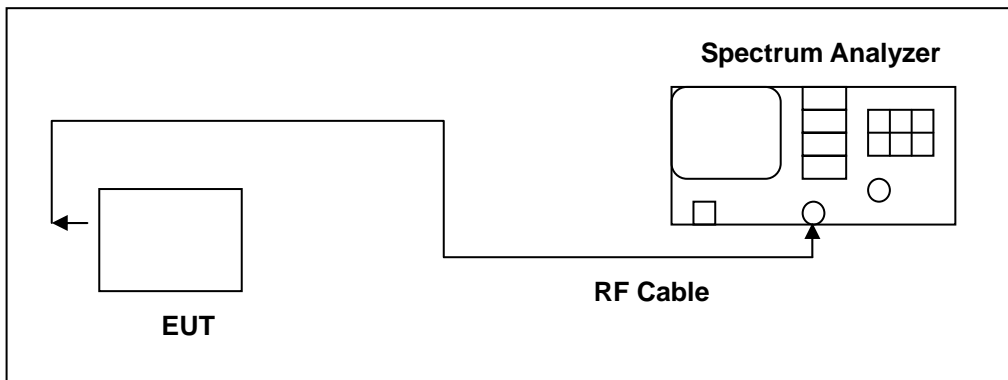

13.3.Test Instruments

Equipment	Manufacturer	Model Number	Serial Number	Cal. Date	Remark
Spectrum Analyzer	Agilent	E4445A	MY46181986	05/16/2011	(2)
Test Site	ATL	TE02	TE02	N.C.R.	-----

Remark: (1) Calibration period 1 year. (2) Calibration period 2 years.

NOTE: N.C.R. = No Calibration Request.

13.4.Test Procedure

The transmitter shall be operated at its maximum carrier power measured under normal test conditions. The span of the analyzer shall be set to capture all products of the modulation process, including the emission skirts. The resolution bandwidth shall be set to as close to 1% of the selected span as is possible without being below 1%. The video bandwidth shall be set to 3 times the resolution bandwidth. Video averaging is not permitted. Where practical, a sampling detector shall be used since a peak or, peak hold, may produce a wider bandwidth than actual.

The trace data points are recovered and are directly summed in linear terms. The recovered amplitude data points, beginning at the lowest frequency, are placed in a running sum until 0.5% of the total is reached and that frequency recorded. The process is repeated for the highest frequency data points. This frequency is recorded.

13.5. Test Result

Model Number	PG76200		
Test Item	99 % Occupied Bandwidth		
Test Mode	Mode 3: GFSK Link Mode		
Date of Test	06/21/2011	Test Site	TE02
	Frequency (MHz)	Measurement (MHz)	Limit (MHz)
	2402	0.9022	-----
	2441	0.8939	-----
	2480	0.8947	-----

Model Number	PG76200		
Test Item	99 % Occupied Bandwidth		
Test Mode	Mode 4: $\pi/4$ -DQPSK Link Mode		
Date of Test	06/21/2011	Test Site	TE02
	Frequency (MHz)	Measurement (MHz)	Limit (MHz)
	2402	1.1910	-----
	2441	1.1892	-----
	2480	1.1943	-----

13.6. Test Graphs

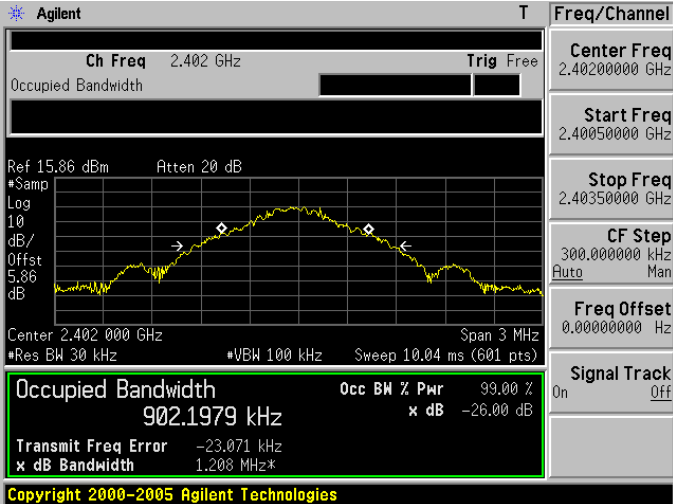
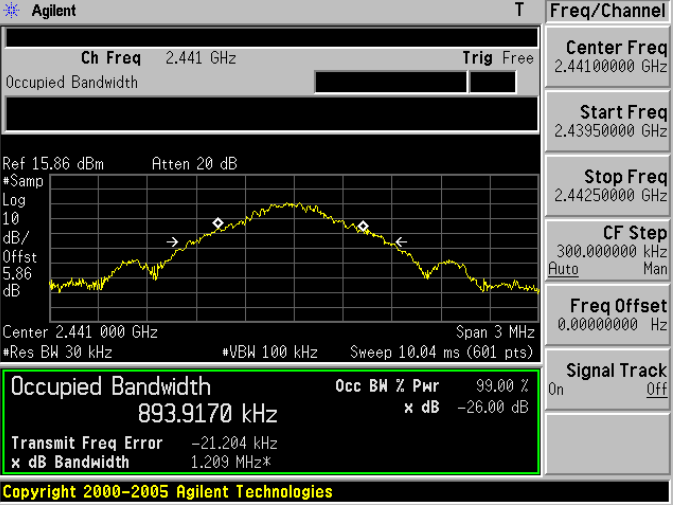
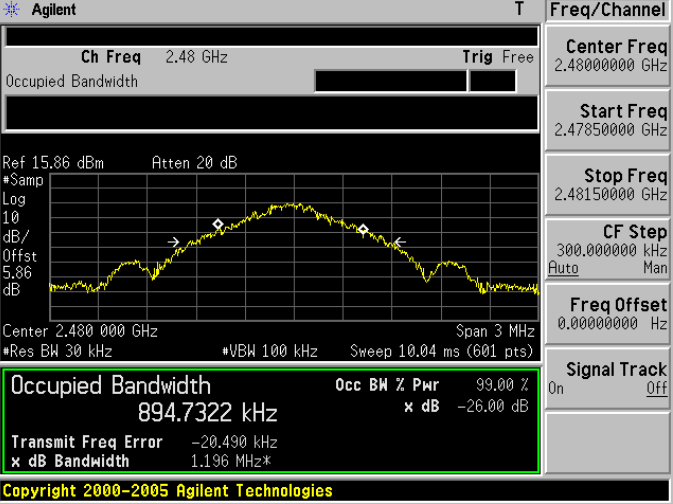
Mode 3: GFSK Link Mode	
2402	 <p>Agilent T</p> <p>Ch Freq 2.402 GHz Trig Free</p> <p>Center Freq 2.40200000 GHz</p> <p>Start Freq 2.40050000 GHz</p> <p>Stop Freq 2.40350000 GHz</p> <p>CF Step 300.000000 kHz Auto Man</p> <p>Freq Offset 0.00000000 Hz</p> <p>Signal Track On Off</p> <p>Ref 15.86 dBm Atten 20 dB</p> <p>#Samp 10</p> <p>Log dB/</p> <p>Offst 5.86 dB</p> <p>Center 2.402 000 GHz Span 3 MHz</p> <p>#Res BW 30 kHz #VBW 100 kHz Sweep 10.04 ms (601 pts)</p> <p>Occupied Bandwidth 902.1979 kHz</p> <p>Occ BW % Pwr 99.00 % x dB -26.00 dB</p> <p>Transmit Freq Error -23.071 kHz</p> <p>x dB Bandwidth 1.208 MHz*</p> <p>Copyright 2000-2005 Agilent Technologies</p>
2441	 <p>Agilent T</p> <p>Ch Freq 2.441 GHz Trig Free</p> <p>Center Freq 2.44100000 GHz</p> <p>Start Freq 2.43950000 GHz</p> <p>Stop Freq 2.44250000 GHz</p> <p>CF Step 300.000000 kHz Auto Man</p> <p>Freq Offset 0.00000000 Hz</p> <p>Signal Track On Off</p> <p>Ref 15.86 dBm Atten 20 dB</p> <p>#Samp 10</p> <p>Log dB/</p> <p>Offst 5.86 dB</p> <p>Center 2.441 000 GHz Span 3 MHz</p> <p>#Res BW 30 kHz #VBW 100 kHz Sweep 10.04 ms (601 pts)</p> <p>Occupied Bandwidth 893.9170 kHz</p> <p>Occ BW % Pwr 99.00 % x dB -26.00 dB</p> <p>Transmit Freq Error -21.204 kHz</p> <p>x dB Bandwidth 1.209 MHz*</p> <p>Copyright 2000-2005 Agilent Technologies</p>
2480	 <p>Agilent T</p> <p>Ch Freq 2.48 GHz Trig Free</p> <p>Center Freq 2.48000000 GHz</p> <p>Start Freq 2.47850000 GHz</p> <p>Stop Freq 2.48150000 GHz</p> <p>CF Step 300.000000 kHz Auto Man</p> <p>Freq Offset 0.00000000 Hz</p> <p>Signal Track On Off</p> <p>Ref 15.86 dBm Atten 20 dB</p> <p>#Samp 10</p> <p>Log dB/</p> <p>Offst 5.86 dB</p> <p>Center 2.480 000 GHz Span 3 MHz</p> <p>#Res BW 30 kHz #VBW 100 kHz Sweep 10.04 ms (601 pts)</p> <p>Occupied Bandwidth 894.7322 kHz</p> <p>Occ BW % Pwr 99.00 % x dB -26.00 dB</p> <p>Transmit Freq Error -20.490 kHz</p> <p>x dB Bandwidth 1.196 MHz*</p> <p>Copyright 2000-2005 Agilent Technologies</p>

Mode 4: $\pi/4$ -DQPSK Link Mode	
2402	<p>Agilent T Freq/Channel</p> <p>Ch Freq 2.402 GHz Trig Free</p> <p>Center Freq 2.40200000 GHz</p> <p>Start Freq 2.40050000 GHz</p> <p>Stop Freq 2.40350000 GHz</p> <p>CF Step 300.000000 kHz Auto Man</p> <p>Freq Offset 0.00000000 Hz</p> <p>Signal Track On Off</p> <p>Ref 15.86 dBm Atten 20 dB</p> <p>Occupied Bandwidth 1.1910 MHz Occ BW % Pwr 99.00 % x dB -26.00 dB</p> <p>Transmit Freq Error -25.576 kHz x dB Bandwidth 1.385 MHz*</p> <p>Copyright 2000-2005 Agilent Technologies</p>
2441	<p>Agilent T Freq/Channel</p> <p>Ch Freq 2.441 GHz Trig Free</p> <p>Center Freq 2.44100000 GHz</p> <p>Start Freq 2.43950000 GHz</p> <p>Stop Freq 2.44250000 GHz</p> <p>CF Step 300.000000 kHz Auto Man</p> <p>Freq Offset 0.00000000 Hz</p> <p>Signal Track On Off</p> <p>Ref 15.86 dBm Atten 20 dB</p> <p>Occupied Bandwidth 1.1892 MHz Occ BW % Pwr 99.00 % x dB -26.00 dB</p> <p>Transmit Freq Error -24.077 kHz x dB Bandwidth 1.380 MHz*</p> <p>Copyright 2000-2005 Agilent Technologies</p>
2480	<p>Agilent T Freq/Channel</p> <p>Ch Freq 2.480 GHz Trig Free</p> <p>Center Freq 2.48000000 GHz</p> <p>Start Freq 2.47850000 GHz</p> <p>Stop Freq 2.48150000 GHz</p> <p>CF Step 300.000000 kHz Auto Man</p> <p>Freq Offset 0.00000000 Hz</p> <p>Signal Track On Off</p> <p>Ref 15.86 dBm Atten 20 dB</p> <p>Occupied Bandwidth 1.1943 MHz Occ BW % Pwr 99.00 % x dB -26.00 dB</p> <p>Transmit Freq Error -23.340 kHz x dB Bandwidth 1.379 MHz*</p> <p>Copyright 2000-2005 Agilent Technologies</p>

14 Antenna Measurement

14.1.Limit

For intentional device, according to 15.203, an intentional radiator shall be designed to ensure that no antenna other than that furnished by the responsible party shall be used with the device.

And According to 15.247 (b), if transmitting antennas of directional gain greater than 6 dBi are used, the power shall be reduced by the amount in dB that the directional gain of the antenna exceeds 6dBi.

14.2.Antenna Connector Construction

The antenna used in this product is **PIFA antenna**. And the maximum Gain of this antenna is only **1.5 dBi**.