

FCC RF Test Report

APPLICANT : HTC Corporation
EQUIPMENT : Tablet PC
MODEL NAME : PG41120
FCC ID : NM8PG41120
STANDARD : FCC Part 15 Subpart C §15.247
CLASSIFICATION : Digital Transmission System (DTS)

The product was received on Jan. 21, 2011 and completely tested on May. 31, 2011. We, SPORTON INTERNATIONAL INC., would like to declare that the tested sample has been evaluated in accordance with the procedures given in ANSI C63.4-2003 and shown the compliance with the applicable technical standards.

The test results in this report apply exclusively to the tested model / sample. Without written approval of SPORTON INTERNATIONAL INC., the test report shall not be reproduced except in full.

Review:



Roy Wu / manager



SPORTON INTERNATIONAL INC.

No. 52, Hwa Ya 1st Rd., Hwa Ya Technology Park, Kwei-Shan Hsiang, Tao Yuan Hsien, Taiwan, R.O.C.



TABLE OF CONTENTS

REVISION HISTORY 3

SUMMARY OF TEST RESULT 4

1 GENERAL DESCRIPTION 5

 1.1 Applicant 5

 1.2 Manufacturer 5

 1.3 Feature of Equipment Under Test 5

 1.4 Testing Site 6

 1.5 Applied Standards 6

 1.6 Ancillary Equipment List 6

2 TEST CONFIGURATION OF EQUIPMENT UNDER TEST 7

 2.1 RF Power 7

 2.2 Test Mode 8

 2.3 Connection Diagram of Test System 9

 2.4 RF Utility 9

3 TEST RESULT 10

 3.1 6dB Bandwidth Measurement 10

 3.2 Output Power Measurement 17

 3.3 Band Edges Measurement 19

 3.4 Spurious Emission Measurement 27

 3.5 Power Spectral Density Measurement 37

 3.6 AC Conducted Emission Measurement 44

 3.7 Radiated Emission Measurement 48

 3.8 Antenna Requirements 69

4 LIST OF MEASURING EQUIPMENT 70

5 UNCERTAINTY OF EVALUATION 71

APPENDIX A. SETUP PHOTOGRAPHS

**SUMMARY OF TEST RESULT**

Report Section	FCC Rule	IC Rule	Description	Limit	Result	Remark
3.1	15.247(a)(2)	A8.2(a)	6dB Bandwidth	$\geq 0.5\text{MHz}$	Pass	-
3.2	15.247(b)	A8.4	Power Output	$\leq 30\text{dBm}$	Pass	-
3.3	15.247(d)	A8.5	Frequency Band Edges	$\leq 20\text{dBc}$	Pass	-
3.4	15.247(d)	A8.5	Spurious Emission	$< 20\text{ dBc}$	Pass	-
3.5	15.247(e)	A8.2(b)	Power Spectral Density	$\leq 8\text{dBm}$	Pass	-
3.6	15.207	Gen 7.2.2	AC Conducted Emission	15.207(a)	Pass	Under limit 17.1 dB at 0.278 MHz
3.7	15.247(d)	A8.5	Transmitter Radiated Emission	15.209(a) & 15.247(d)	Pass	Under limit 3.91 dB at 2389.99 MHz
3.8	15.203 & 15.247(b)	A8.4	Antenna Requirement	N/A	Pass	-

1 General Description

1.1 Applicant

HTC Corporation

No. 23, Xinghua Road, Taoyuan City, Taoyuan County 330, Taiwan

1.2 Manufacturer

HTC Corporation

No. 23, Xinghua Road, Taoyuan City, Taoyuan County 330, Taiwan

1.3 Feature of Equipment Under Test

Product Feature & Specification	
Equipment	Tablet PC
Model Name	PG41120
FCC ID	NM8PG41120
Tx/Rx Frequency Range	2400 MHz ~ 2483.5 MHz
Number of Channels	11
Carrier Frequency of Each Channel	2412+(n-1)*5 MHz; n=1~11
Channel Spacing	5 MHz
Maximum Output Power to Antenna	802.11b : 20.98 dBm (0.13 W) 802.11g : 22.02 dBm (0.16 W) 802.11n (BW 20MHz) : 21.71 dBm (0.15 W)
Antenna Type	PIFA Antenna with gain -3.95 dBi
Type of Modulation	802.11b : DSSS (BPSK / QPSK / CCK) 802.11g/n : OFDM (BPSK / QPSK / 16QAM / 64QAM)
EUT Stage	Identical Prototype

Remark:

1. For other wireless features of this EUT, test report will be issued separately.
2. This test report recorded only product characteristics and test results of Digital Transmission System (DTS).
3. The above EUT's information was declared by manufacturer. Please refer to the specifications or user's manual for more detailed description.

1.4 Testing Site

Test Site	SPORTON INTERNATIONAL INC.		
Test Site Location	No. 52, Hwa Ya 1 st Rd., Hwa Ya Technology Park, Kwei-Shan Hsiang, Tao Yuan Hsien, Taiwan, R.O.C. TEL: +886-3-3273456 / FAX: +886-3-3284978		
Test Site No.	Sporton Site No.		FCC/IC Registration No.
	CO05-HY	03CH07-HY	722060/4086B-1

1.5 Applied Standards

According to the specifications of the manufacturer, the EUT must comply with the requirements of the following standards:

- ♦ FCC Part 15 Subpart C §15.247
- ♦ FCC KDB Publication No. 558074 (Measurement Guidelines of DTS)
- ♦ ANSI C63.4-2003
- ♦ IC RSS-210 Issue 8

Remark:

1. All test items were verified and recorded according to the standards and without any deviation during the test.
2. This EUT has also been tested and complied with the requirements of FCC Part 15, Subpart B (DoC), recorded in a separate test report.

1.6 Ancillary Equipment List

Item	Equipment	Trade Name	Model Name	FCC ID	Data Cable	Power Cord
1.	System Simulator	R&S	CMU 200	N/A	N/A	Unshielded, 1.8 m
2.	GPS Station	T&E	GS-50	N/A	N/A	Unshielded, 1.8 m
3.	WLAN AP	D-Link	DIR-628	KA2DIR628A2	N/A	Unshielded, 1.8 m
4.	Notebook	DELL	Vostro 1510	FCC DoC	N/A	AC I/P: Unshielded, 1.2 m DC O/P: Shielded, 1.8 m
5.	Bluetooth Earphone	Nokia	BH-102	PYAHS-107W	N/A	N/A

2 Test Configuration of Equipment Under Test

2.1 RF Power

Preliminary tests were performed in different data rate and recorded the RF peak power output in the following table:

Channel	Frequency	2.4GHz 802.11b RF Power (dBm)			
		DSSS Data Rate			
		1 Mbps	2 Mbps	5.5 Mbps	11 Mbps
CH 01	2412 MHz	19.64	-	-	-
CH 06	2437 MHz	20.25	-	-	-
CH 11	2462 MHz	20.98	20.95	20.78	20.95

Channel	Frequency	2.4GHz 802.11g RF Power (dBm)							
		OFDM Data Rate							
		6 Mbps	9 Mbps	12 Mbps	18 Mbps	24 Mbps	36 Mbps	48 Mbps	54 Mbps
CH 01	2412 MHz	21.45	-	-	-	-	-	-	-
CH 06	2437 MHz	21.69	-	-	-	-	-	-	-
CH 11	2462 MHz	22.02	21.96	21.86	21.80	21.79	21.75	21.74	21.82

Channel	Frequency	2.4GHz 802.11n (BW 20MHz) RF Power (dBm)							
		OFDM Data Rate							
		M0	M1	M2	M3	M4	M5	M6	M7
CH 01	2412 MHz	20.95	-	-	-	-	-	-	-
CH 06	2437 MHz	21.18	-	-	-	-	-	-	-
CH 11	2462 MHz	21.71	21.33	21.24	21.18	21.17	21.09	21.25	21.11

Remark:

1. The data rates of WLAN 802.11b/g/n were set in 1Mbps for 802.11b, 6Mbps for 802.11g, and M0 for 802.11n (BW 20MHz) for all the test cases due to the highest RF peak output power.
2. The EUT is programmed to transmit signals continuously for all testing.

2.2 Test Mode

The EUT has been associated with peripherals pursuant to ANSI C63.4-2003 and configuration operated in a manner tended to maximize its emission characteristics in a typical application. Frequency range investigated: conducted emission (150 kHz to 30 MHz), radiated emission (30 MHz to the 10th harmonic of the highest fundamental frequency or to 40 GHz, whichever is lower).

Pre-scanned tests were conducted to determine the final configuration from all possible combinations.

The following tables are showing the test modes as the worst cases and recorded in this report.

Test Cases	
Test Item	802.11b (Modulation : DSSS) 802.11g/n (Modulation : OFDM)
Conducted TCs	Mode 1 : 802.11b CH01_2412 MHz Mode 2 : 802.11b CH06_2437 MHz Mode 3 : 802.11b CH11_2462 MHz Mode 4: 802.11g_CH01_2412 MHz Mode 5: 802.11g_CH06_2437 MHz Mode 6: 802.11g_CH11_2462 MHz Mode 7: 802.11n (BW 20M)_CH01_2412 MHz Mode 8: 802.11n (BW 20M)_CH06_2437 MHz Mode 9: 802.11n (BW 20M)_CH11_2462 MHz
Radiated TCs	Mode 1 : 802.11b CH01_2412 MHz + TC Mode 2 : 802.11b CH06_2437 MHz + TC Mode 3 : 802.11b CH11_2462 MHz + TC Mode 4: 802.11g_CH01_2412 MHz + TC Mode 5: 802.11g_CH06_2437 MHz + TC Mode 6: 802.11g_CH11_2462 MHz + TC Mode 7: 802.11n (BW 20M)_CH01_2412 MHz + TC Mode 8: 802.11n (BW 20M)_CH06_2437 MHz + TC Mode 9: 802.11n (BW 20M)_CH11_2462 MHz + TC
AC Conducted Emission	Mode 1 : GSM850 Idle + Bluetooth Link + WLAN Link + GPS Rx + Earphone 1 + Adapter
Remark:	
1. TC stands for Test Configuration, and consists of earphone 1 and adapter.	

2.3 Connection Diagram of Test System

<WLAN Tx Mode>

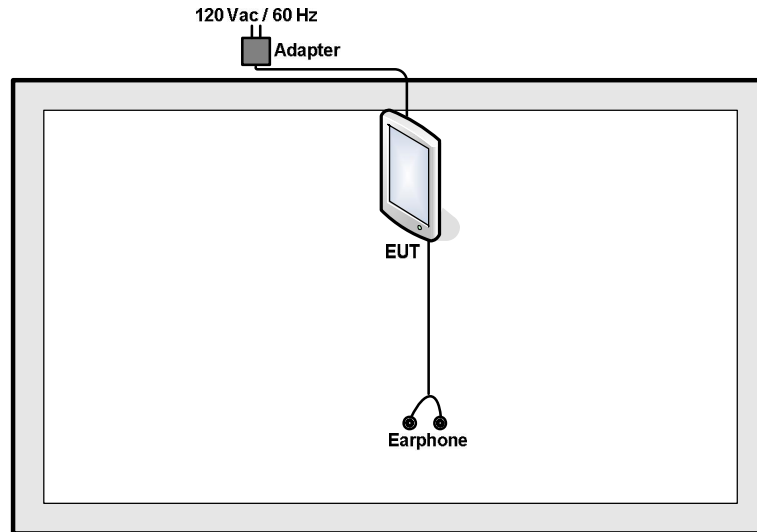

<AC Conducted Emission Mode>

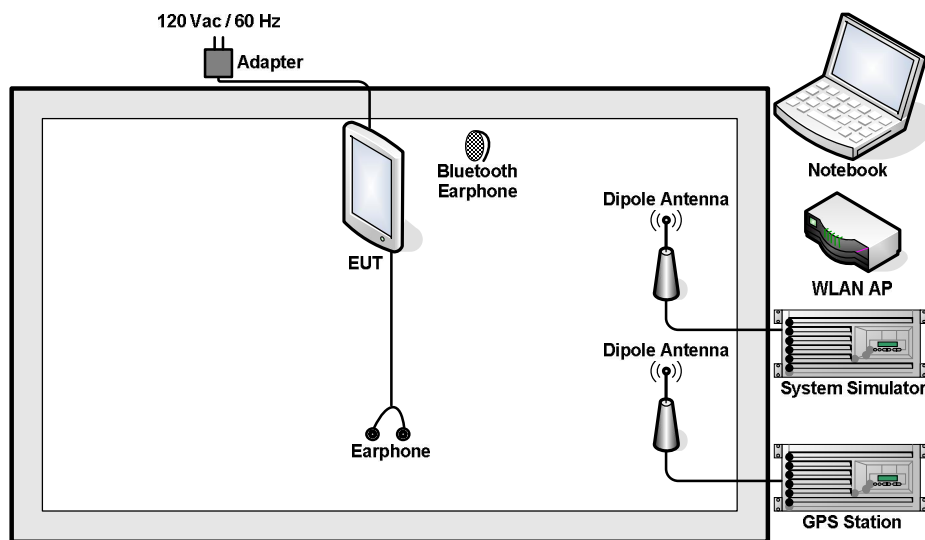

2.4 RF Utility

The programmed RF utility "shortcut to WiFiTool.exe" is installed in EUT to provide channel selection, power level, data rate and the application type. RF utility can send transmitting signal for all testing. The RF output power selection is for the setting of RF output power expected by the customer and is going to be fixed on the firmware of the final end product.

3 Test Result

3.1 6dB Bandwidth Measurement

3.1.1 Limit of 6dB Bandwidth

The minimum 6 dB bandwidth shall be at least 500 kHz.

3.1.2 Measuring Instruments

See list of measuring instruments of this test report.

3.1.3 Test Procedures

1. The testing follows FCC KDB Publication No. 558074 (Measurement Guidelines of DTS).
2. The RF output of EUT was connected to the spectrum analyzer by a low loss cable.
3. Make the measurement with the spectrum analyzer's resolution bandwidth (RBW) = 100 kHz.
In order to make an accurate measurement, set the span greater than RBW. The 6 dB bandwidth must be greater than 500 kHz.
4. The marker-delta reading at this point is the 6 dB bandwidth of the emission.

3.1.4 Test Setup

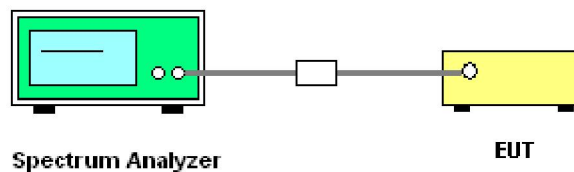



3.1.5 Test Result of 6dB Bandwidth

Test Mode :	Mode 1, 2, 3	Temperature :	25~27°C
Test Engineer :	Alan Liu	Relative Humidity :	45~48%

Channel	Frequency (MHz)	802.11b 6dB Bandwidth (MHz)	6dB Bandwidth Min. Limit (MHz)	Pass/Fail
01	2412	7.06	0.5	Pass
06	2437	7.06	0.5	Pass
11	2462	7.52	0.5	Pass

Mode 1 : 6 dB Bandwidth Plot on 802.11b Channel 01

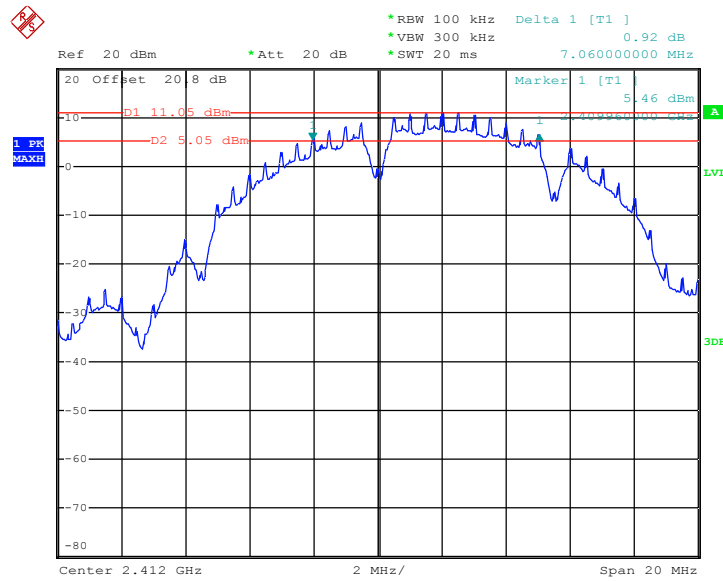

Date: 28.JAN.2011 23:05:15



Mode 2 : 6 dB Bandwidth Plot on 802.11b Channel 06

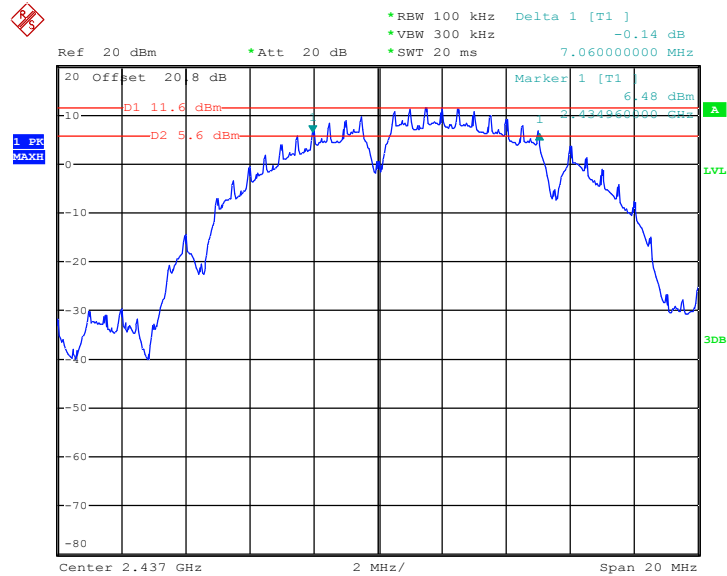

Date: 28.JAN.2011 23:22:35

Mode 3 : 6 dB Bandwidth Plot on 802.11b Channel 11

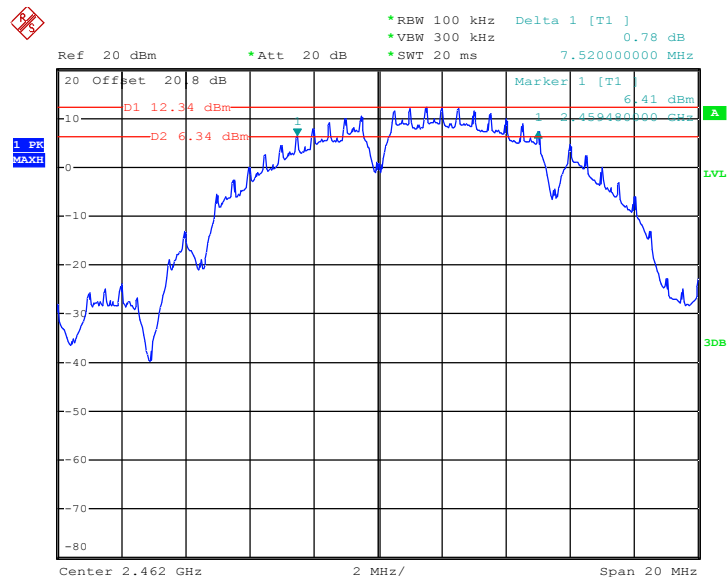

Date: 28.JAN.2011 23:34:17



Test Mode :	Mode 4, 5, 6	Temperature :	25~27°C
Test Engineer :	Alan Liu	Relative Humidity :	45~48%

Channel	Frequency (MHz)	802.11g 6dB Bandwidth (MHz)	6dB Bandwidth Min. Limit (MHz)	Pass/Fail
01	2412	15.12	0.5	Pass
06	2437	15.12	0.5	Pass
11	2462	15.12	0.5	Pass

Mode 4 : 6 dB Bandwidth Plot on 802.11g Channel 01

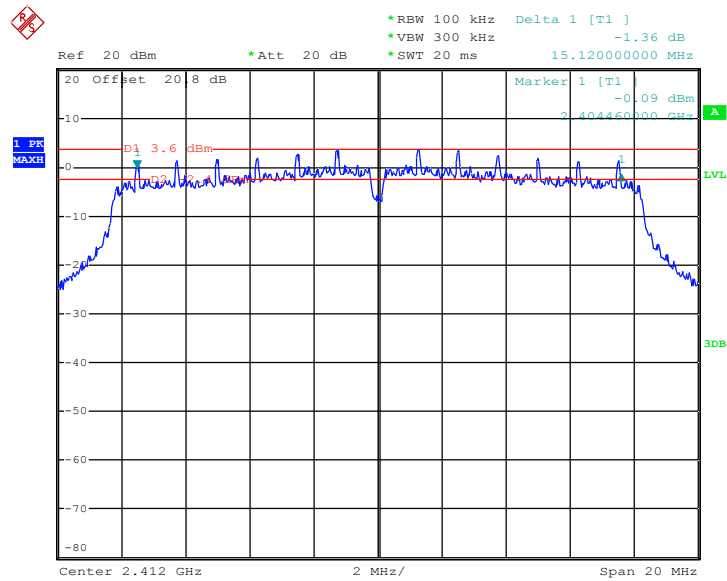

Date: 28.JAN.2011 23:48:02



Mode 5 : 6 dB Bandwidth Plot on 802.11g Channel 06

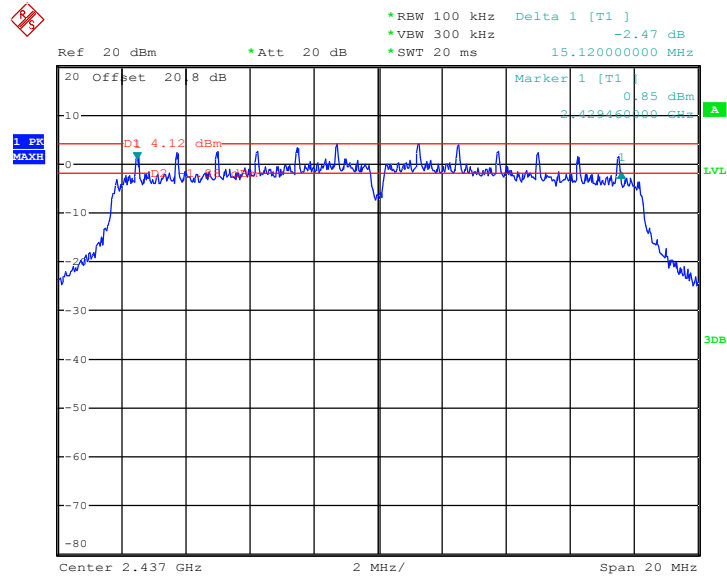

Date: 29.JAN.2011 00:00:50

Mode 6 : 6 dB Bandwidth Plot on 802.11g Channel 11

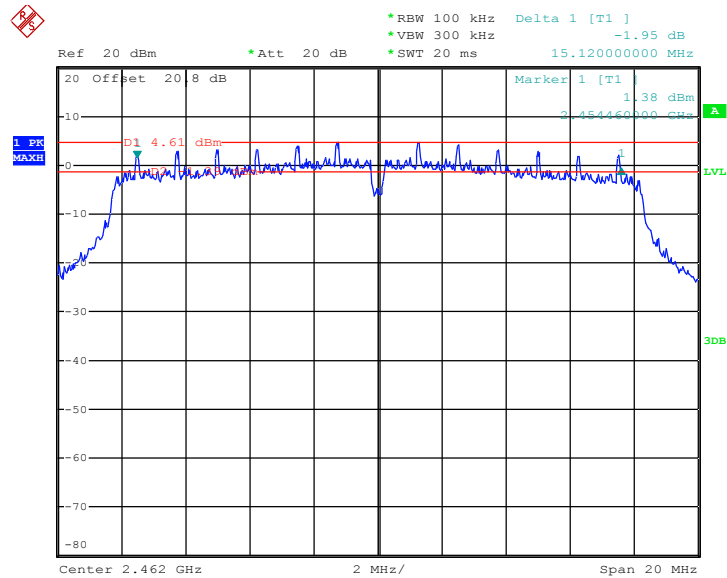

Date: 29.JAN.2011 00:12:39



Test Mode :	Mode 7, 8, 9	Temperature :	25~27°C
Test Engineer :	Alan Liu	Relative Humidity :	45~48%

Channel	Frequency (MHz)	802.11n (BW 20MHz) 6dB Bandwidth (MHz)	6dB Bandwidth Min. Limit (MHz)	Pass/Fail
01	2412	15.12	0.5	Pass
06	2437	15.08	0.5	Pass
11	2462	15.14	0.5	Pass

Mode 7 : 6 dB Bandwidth Plot on 802.11n(BW 20MHz) Channel 01

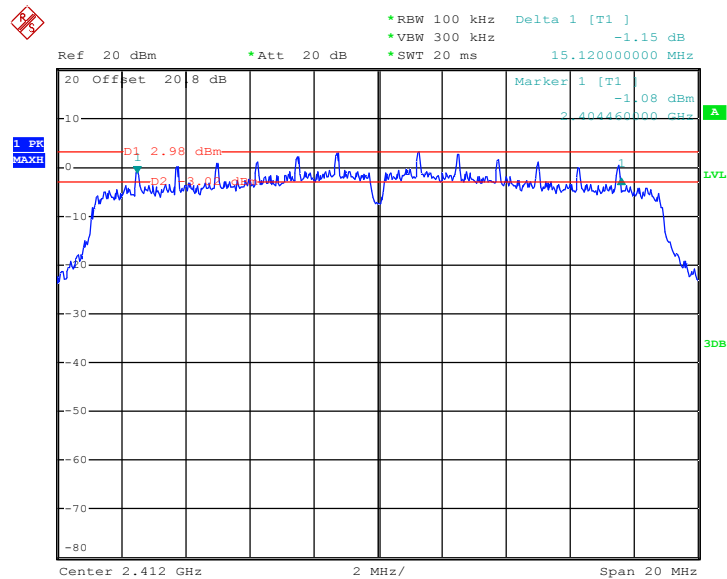

Date: 29.JAN.2011 00:26:58



Mode 8 : 6 dB Bandwidth Plot on 802.11n(BW 20MHz) Channel 06

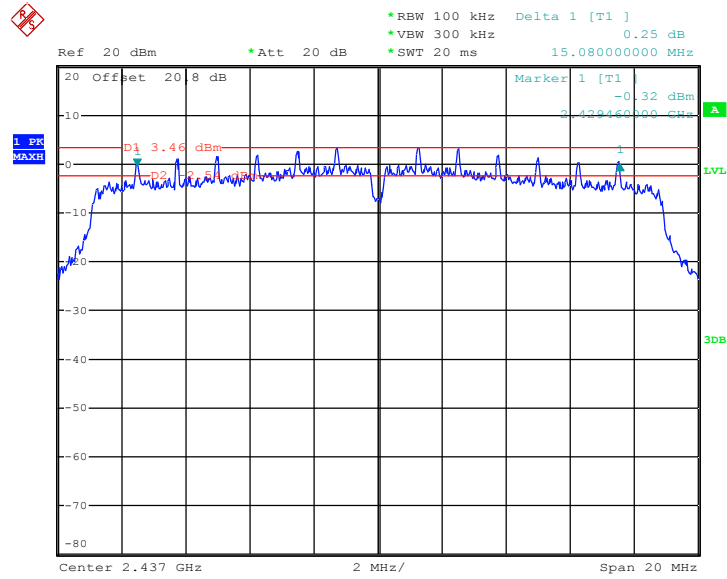

Date: 29.JAN.2011 00:40:14

Mode 9 : 6 dB Bandwidth Plot on 802.11n(BW 20MHz) Channel 11

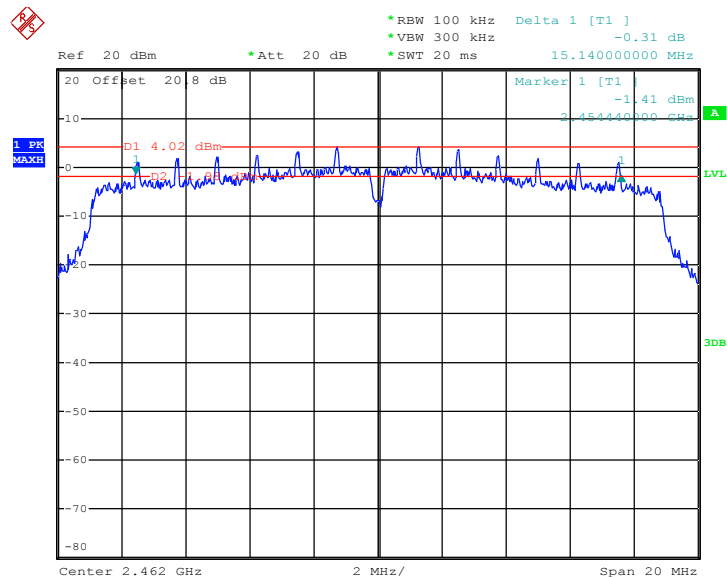

Date: 29.JAN.2011 00:51:11

3.2 Output Power Measurement

3.2.1 Limit of Output Power

For systems using digital modulation in the 2400-2483.5MHz, the limit for peak output power is 30dBm. If transmitting antenna of directional gain greater than 6dBi are used the peak output power from the intentional radiator shall be reduced below the above stated value by the amount in dB that the directional gain of the antenna exceeds 6 dBi. In case of point-to-point operation, the limit has to be reduced by 1dB for every 3dB that the directional gain of the antenna exceeds 6dBi.

3.2.2 Measuring Instruments

See list of measuring instruments of this test report.

3.2.3 Test Procedures

1. The testing follows FCC KDB Publication No. 558074 (Measurement Guidelines of DTS).
2. The RF output of EUT was connected to the power meter by a low loss cable.
3. Measure the power by power meter.

3.2.4 Test Setup

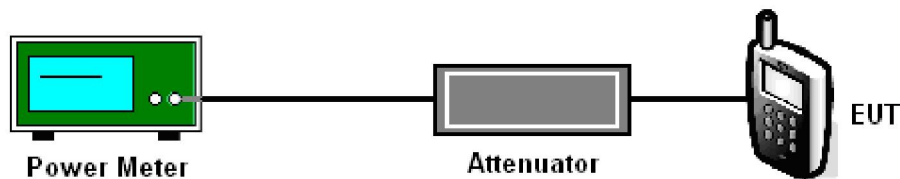



3.2.5 Test Result of Output Power

Test Mode :	Mode 1, 2, 3	Temperature :	25~27°C
Test Engineer :	Alan Liu	Relative Humidity :	45~48%

Channel	Frequency (MHz)	802.11b Measured Output Power (dBm)	Max. Limits (dBm)	Pass/Fail
01	2412	19.64	30	Pass
06	2437	20.25	30	Pass
11	2462	20.98	30	Pass

Test Mode :	Mode 4, 5, 6	Temperature :	25~27°C
Test Engineer :	Alan Liu	Relative Humidity :	45~48%

Channel	Frequency (MHz)	802.11g Measured Output Power (dBm)	Max. Limits (dBm)	Pass/Fail
01	2412	21.45	30	Pass
06	2437	21.69	30	Pass
11	2462	22.02	30	Pass

Test Mode :	Mode 7, 8, 9	Temperature :	25~27°C
Test Engineer :	Alan Liu	Relative Humidity :	45~48%

Channel	Frequency (MHz)	802.11n (BW 20MHz) Measured Output Power (dBm)	Max. Limits (dBm)	Pass/Fail
01	2412	20.95	30	Pass
06	2437	21.18	30	Pass
11	2462	21.71	30	Pass



3.3 Band Edges Measurement

3.3.1 Limit of Band Edges

In any 100 kHz bandwidth outside the intentional radiation frequency band, the radio frequency power shall be at least 20 dB below the highest level of the radiated power. If the output power of this device was measured by spectrum analyzer, the attenuation under this paragraph shall be 30 dB instead of 20 dB.

3.3.2 Measuring Instruments

See list of measuring instruments of this test report.

3.3.3 Test Procedures

1. The testing follows the guidelines in ANSI C63.4-2003 and FCC KDB Publication No. 558074 (Measurement Guidelines of DTS).
2. Conducted emission test: Set RBW = 100 kHz, Video bandwidth (VBW) \geq RBW. Band edge emissions must be at least 20 dB down from the highest emission level within the authorized band as measured with a 100 kHz RBW. Note: If the device complies with the use of power option 2 the attenuation under this paragraph shall be 30 dB instead of 20 dB.
3. Radiated emission test: Apply to band edge emissions that fall in the restricted bands listed in FCC Section 15.205. The maximum permitted average field strength is listed in FCC Section 15.209. A pre-amp is necessary for this measurement. For measurements above 1 GHz, set RBW = 1MHz, VBW = 10 Hz, Sweep=Auto. If the emission is pulsed, modify the unit for continuous operation; use the settings shown above, then correct the reading by subtracting the peak-average correction factor, derived from the appropriate duty cycle calculation as in FCC Section 15.35(b) and (c).

3.3.4 Test Setup

<Radiated Band Edges>

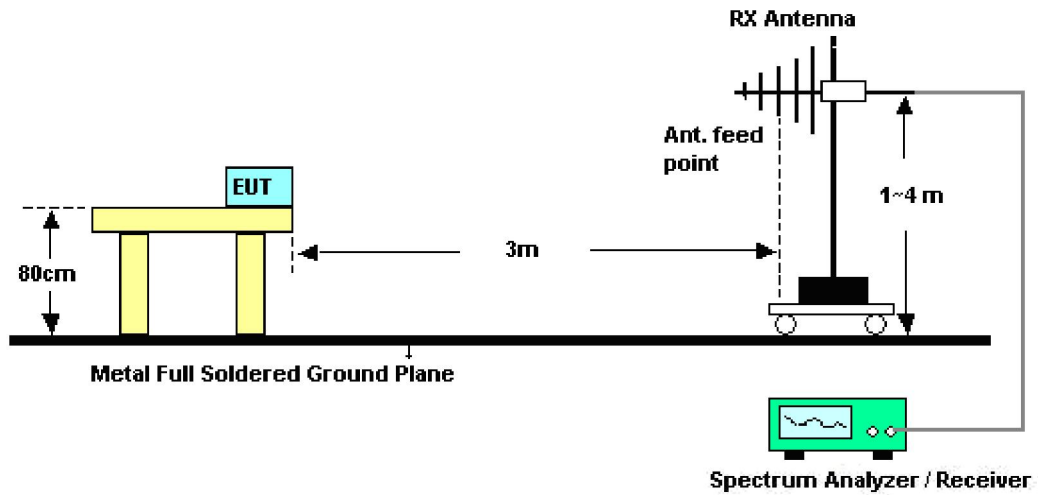

<Conducted Band Edges>

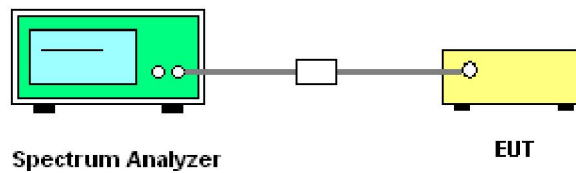



3.3.5 Test Result of Radiated Band Edges

Test Mode :	Mode 1	Temperature :	21~22°C
Test Band :	802.11b	Relative Humidity :	47~49%
Test Channel :	01	Test Engineer :	David Yang

ANTENNA POLARITY : HORIZONTAL										
Frequency (MHz)	Level (dBuV/m)	Over Limit (dB)	Limit Line (dBuV/m)	Read Level (dBuV)	Antenna Factor (dB)	Cable Loss (dB)	Preamp Factor (dB)	Ant Pos (cm)	Table Pos (deg)	Remark
2389.99	56.89	-17.11	74	52.53	32.18	6.03	33.85	141	360	Peak
2389.99	44.87	-9.13	54	40.51	32.18	6.03	33.85	141	360	Average

ANTENNA POLARITY : VERTICAL										
Frequency (MHz)	Level (dBuV/m)	Over Limit (dB)	Limit Line (dBuV/m)	Read Level (dBuV)	Antenna Factor (dB)	Cable Loss (dB)	Preamp Factor (dB)	Ant Pos (cm)	Table Pos (deg)	Remark
2389.42	56.45	-17.55	74	52.09	32.18	6.03	33.85	100	170	Peak
2389.42	44.23	-9.77	54	39.87	32.18	6.03	33.85	100	170	Average

Test Mode :	Mode 3	Temperature :	21~22°C
Test Band :	802.11b	Relative Humidity :	47~49%
Test Channel :	11	Test Engineer :	David Yang

ANTENNA POLARITY : HORIZONTAL										
Frequency (MHz)	Level (dBuV/m)	Over Limit (dB)	Limit Line (dBuV/m)	Read Level (dBuV)	Antenna Factor (dB)	Cable Loss (dB)	Preamp Factor (dB)	Ant Pos (cm)	Table Pos (deg)	Remark
2483.5	55.98	-18.02	74	51.42	32.28	6.18	33.9	137	360	Peak
2483.5	45.36	-8.64	54	40.8	32.28	6.18	33.9	137	360	Average

ANTENNA POLARITY : VERTICAL										
Frequency (MHz)	Level (dBuV/m)	Over Limit (dB)	Limit Line (dBuV/m)	Read Level (dBuV)	Antenna Factor (dB)	Cable Loss (dB)	Preamp Factor (dB)	Ant Pos (cm)	Table Pos (deg)	Remark
2483.5	56.72	-17.28	74	52.16	32.28	6.18	33.9	100	191	Peak
2483.5	46.18	-7.82	54	41.62	32.28	6.18	33.9	100	191	Average



Test Mode :	Mode 4	Temperature :	21~22°C
Test Band :	802.11g	Relative Humidity :	47~49%
Test Channel :	01	Test Engineer :	David Yang

ANTENNA POLARITY : HORIZONTAL										
Frequency (MHz)	Level (dBuV/m)	Over Limit (dB)	Limit Line (dBuV/m)	Read Level (dBuV)	Antenna Factor (dB)	Cable Loss (dB)	Preamp Factor (dB)	Ant Pos (cm)	Table Pos (deg)	Remark
2389.61	68.89	-5.11	74	64.53	32.18	6.03	33.85	148	360	Peak
2389.61	48.51	-5.49	54	44.15	32.18	6.03	33.85	148	360	Average

ANTENNA POLARITY : VERTICAL										
Frequency (MHz)	Level (dBuV/m)	Over Limit (dB)	Limit Line (dBuV/m)	Read Level (dBuV)	Antenna Factor (dB)	Cable Loss (dB)	Preamp Factor (dB)	Ant Pos (cm)	Table Pos (deg)	Remark
2389.99	68.65	-5.35	74	64.29	32.18	6.03	33.85	100	23	Peak
2389.99	47.13	-6.87	54	42.77	32.18	6.03	33.85	100	23	Average

Test Mode :	Mode 6	Temperature :	21~22°C
Test Band :	802.11g	Relative Humidity :	47~49%
Test Channel :	11	Test Engineer :	David Yang

ANTENNA POLARITY : HORIZONTAL										
Frequency (MHz)	Level (dBuV/m)	Over Limit (dB)	Limit Line (dBuV/m)	Read Level (dBuV)	Antenna Factor (dB)	Cable Loss (dB)	Preamp Factor (dB)	Ant Pos (cm)	Table Pos (deg)	Remark
2483.5	66.48	-7.52	74	61.92	32.28	6.18	33.9	118	28	Peak
2483.5	44.47	-9.53	54	39.91	32.28	6.18	33.9	118	28	Average

ANTENNA POLARITY : VERTICAL										
Frequency (MHz)	Level (dBuV/m)	Over Limit (dB)	Limit Line (dBuV/m)	Read Level (dBuV)	Antenna Factor (dB)	Cable Loss (dB)	Preamp Factor (dB)	Ant Pos (cm)	Table Pos (deg)	Remark
2483.5	65.61	-8.39	74	61.05	32.28	6.18	33.9	124	4	Peak
2483.5	43.89	-10.11	54	39.33	32.28	6.18	33.9	124	4	Average



Test Mode :	Mode 7	Temperature :	21~22°C
Test Band :	802.11n (BW 20MHz)	Relative Humidity :	47~49%
Test Channel :	01	Test Engineer :	David Yang

ANTENNA POLARITY : HORIZONTAL										
Frequency (MHz)	Level (dBuV/m)	Over Limit (dB)	Limit Line (dBuV/m)	Read Level (dBuV)	Antenna Factor (dB)	Cable Loss (dB)	Preamp Factor (dB)	Ant Pos (cm)	Table Pos (deg)	Remark
2389.99	70.09	-3.91	74	65.73	32.18	6.03	33.85	147	313	Peak
2389.99	50.02	-3.98	54	45.66	32.18	6.03	33.85	147	313	Average

ANTENNA POLARITY : VERTICAL										
Frequency (MHz)	Level (dBuV/m)	Over Limit (dB)	Limit Line (dBuV/m)	Read Level (dBuV)	Antenna Factor (dB)	Cable Loss (dB)	Preamp Factor (dB)	Ant Pos (cm)	Table Pos (deg)	Remark
2388.85	67.07	-6.93	74	62.71	32.18	6.03	33.85	102	165	Peak
2388.85	46.39	-7.61	54	42.03	32.18	6.03	33.85	102	165	Average

Test Mode :	Mode 9	Temperature :	21~22°C
Test Band :	802.11n (BW 20MHz)	Relative Humidity :	47~49%
Test Channel :	11	Test Engineer :	David Yang

ANTENNA POLARITY : HORIZONTAL										
Frequency (MHz)	Level (dBuV/m)	Over Limit (dB)	Limit Line (dBuV/m)	Read Level (dBuV)	Antenna Factor (dB)	Cable Loss (dB)	Preamp Factor (dB)	Ant Pos (cm)	Table Pos (deg)	Remark
2483.5	64.11	-9.89	74	59.55	32.28	6.18	33.9	120	27	Peak
2483.5	44.38	-9.62	54	39.82	32.28	6.18	33.9	120	27	Average

ANTENNA POLARITY : VERTICAL										
Frequency (MHz)	Level (dBuV/m)	Over Limit (dB)	Limit Line (dBuV/m)	Read Level (dBuV)	Antenna Factor (dB)	Cable Loss (dB)	Preamp Factor (dB)	Ant Pos (cm)	Table Pos (deg)	Remark
2483.85	58.99	-15.01	74	54.43	32.28	6.18	33.9	103	189	Peak
2483.85	40.85	-13.15	54	36.29	32.28	6.18	33.9	103	189	Average



3.3.6 Test Plots of Conducted Band Edges

Test Mode :	Mode 1 and 3	Temperature :	25~27°C
Test Band :	802.11b	Relative Humidity :	45~48%
Test Channel :	01 and 11	Test Engineer :	Alan Liu

Low Band Edge Plot on 802.11b Channel 01

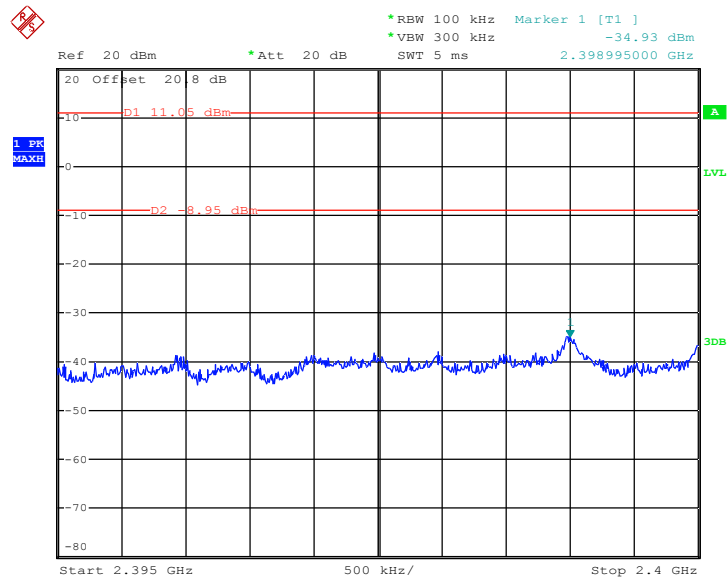

Date: 28.JAN.2011 23:09:10

High Band Edge Plot on 802.11b Channel 11

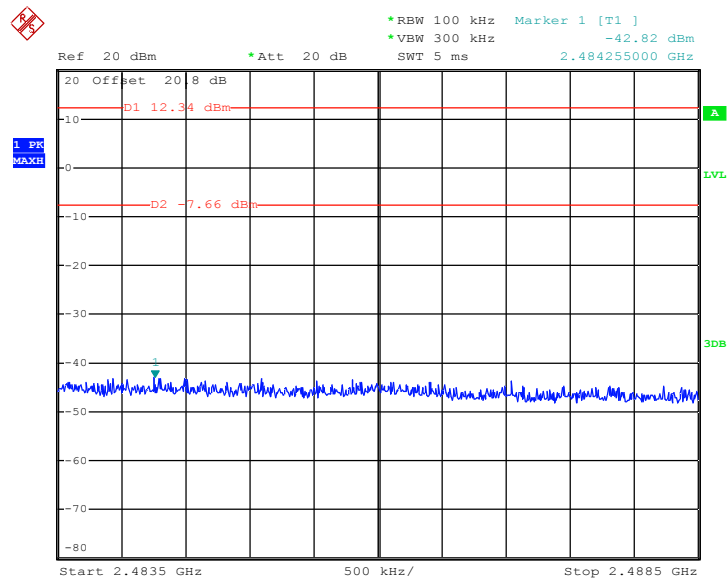

Date: 28.JAN.2011 23:35:04



Test Mode :	Mode 4 and 6	Temperature :	25~27°C
Test Band :	802.11g	Relative Humidity :	45~48%
Test Channel :	01 and 11	Test Engineer :	Alan Liu

Low Band Edge Plot on 802.11g Channel 01

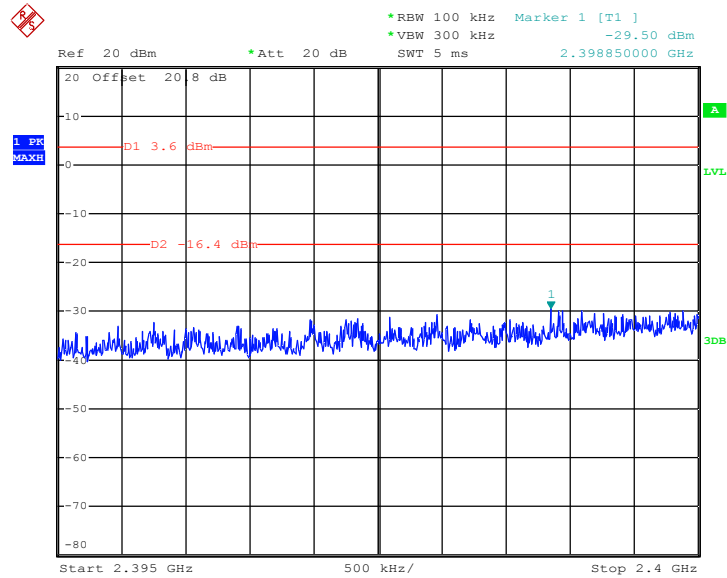

Date: 28.JAN.2011 23:49:10

High Band Edge Plot on 802.11g Channel 11

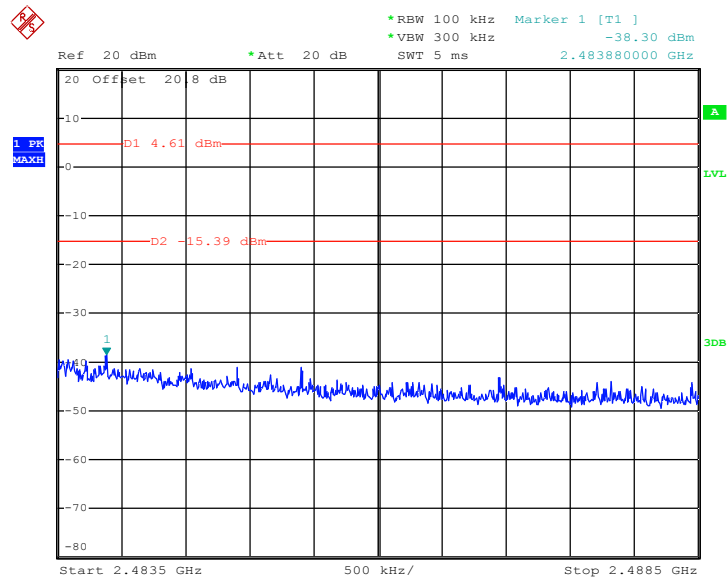

Date: 29.JAN.2011 00:13:26



Test Mode :	Mode 7 and 9	Temperature :	25~27°C
Test Band :	802.11n (BW 20MHz)	Relative Humidity :	45~48%
Test Channel :	01 and 11	Test Engineer :	Alan Liu

Low Band Edge Plot on 802.11n (BW 20MHz) Channel 01

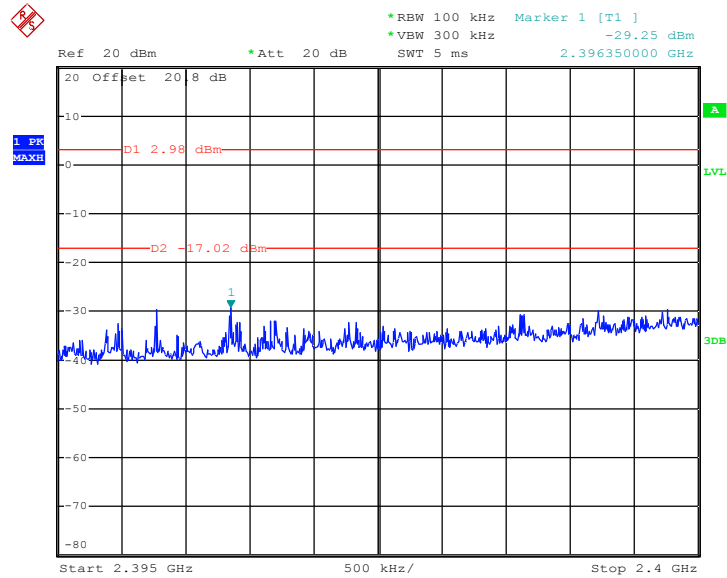

Date: 29.JAN.2011 00:28:07

High Band Edge Plot on 802.11n (BW 20MHz) Channel 11

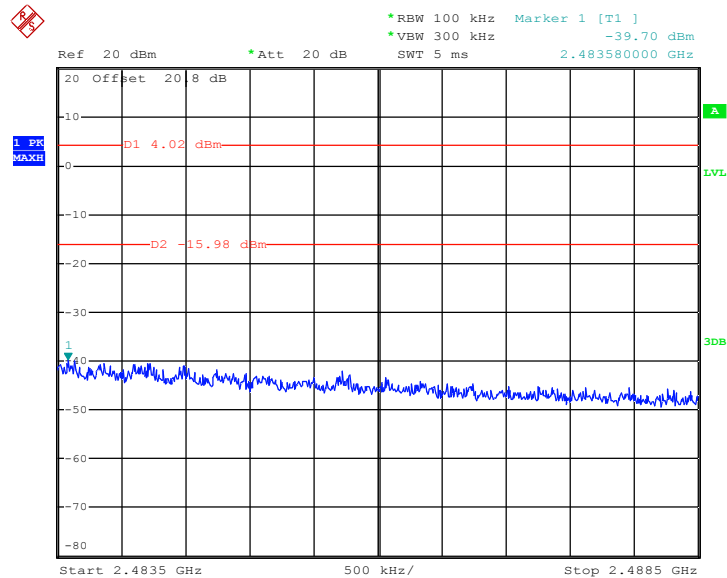

Date: 29.JAN.2011 00:51:58

3.4 Spurious Emission Measurement

3.4.1 Limit of Spurious Emission Measurement

All harmonics/spurious must be at least 20 dB down from the highest emission level within the authorized band.

3.4.2 Measuring Instruments

See list of measuring instruments of this test report.

3.4.3 Test Procedure

1. The transmitter output was connected to the spectrum analyzer via a low lose cable.
2. Set RBW = 100 kHz, Video bandwidth (VBW) \geq RBW, scan up through 10th harmonic. All harmonics/spurs must be at least 20 dB down from the highest emission level within the authorized band as measured with a 100 kHz RBW.

3.4.4 Test Setup

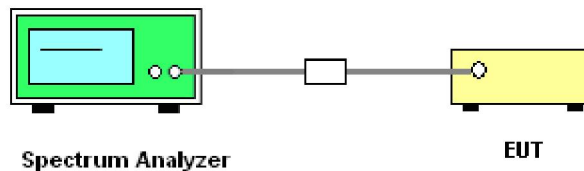

3.4.5 Test Plots of Spurious Emission

Test Mode :	Mode 1	Temperature :	25~27°C
Test Band :	802.11b	Relative Humidity :	45~48%
Test Channel :	01	Test Engineer :	Alan Liu

Conducted Spurious Emission Plot between 30MHz ~ 3 GHz

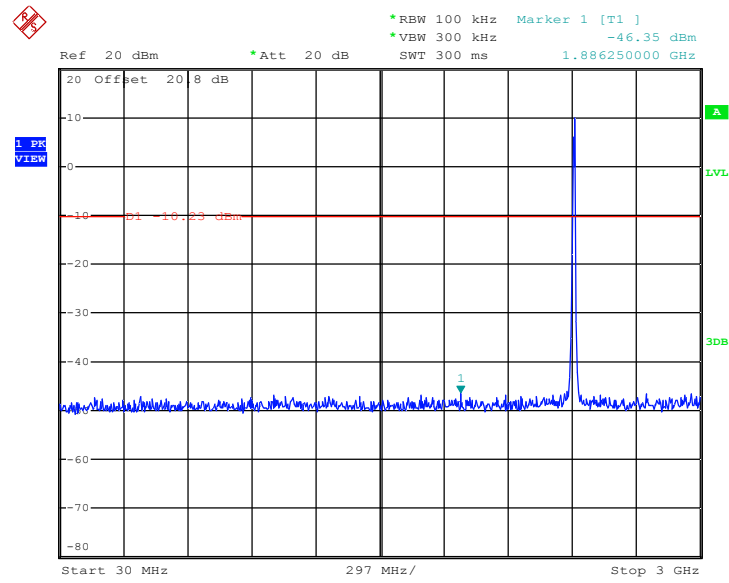

Date: 28.JAN.2011 23:10:39

Conducted Spurious Emission Plot between 3 GHz ~ 25 GHz

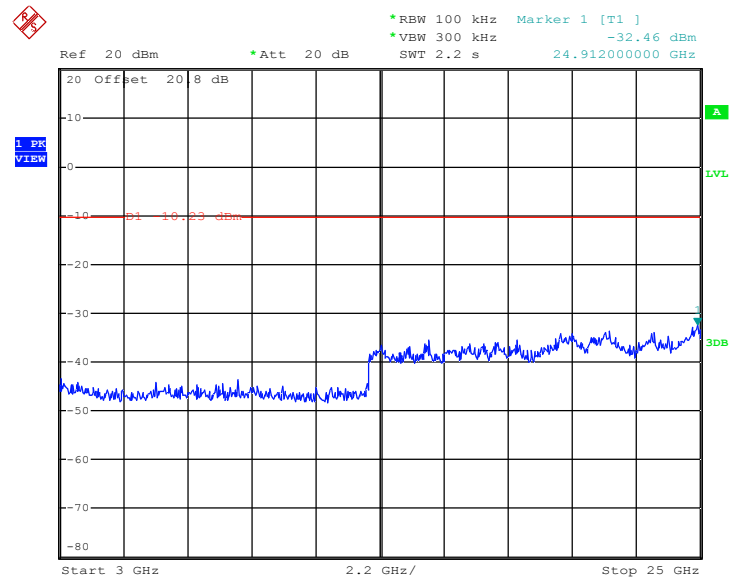

Date: 28.JAN.2011 23:10:56



Test Mode :	Mode 2	Temperature :	25~27°C
Test Band :	802.11b	Relative Humidity :	45~48%
Test Channel :	06	Test Engineer :	Alan Liu

Conducted Spurious Emission Plot between 30MHz ~ 3 GHz

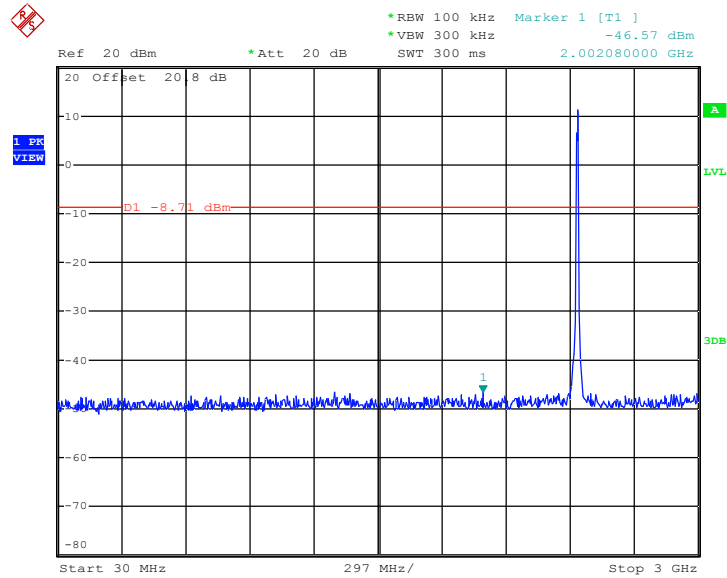

Date: 28.JAN.2011 23:32:03

Conducted Spurious Emission Plot between 3 GHz ~ 25 GHz

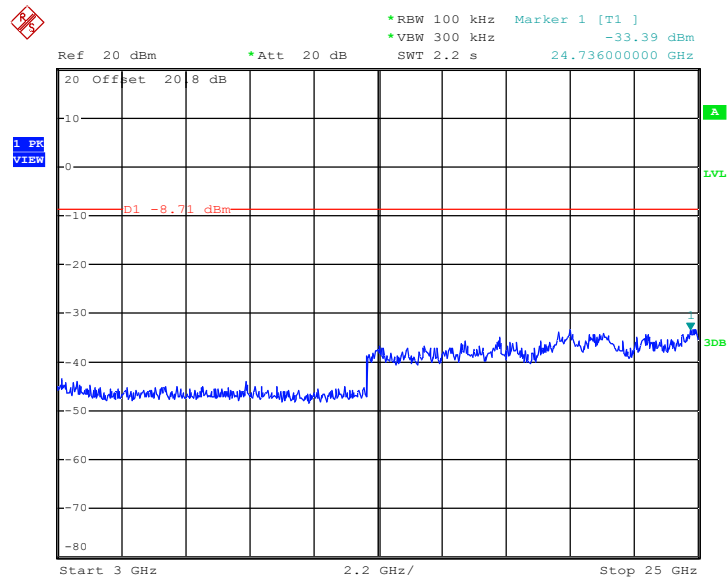

Date: 28.JAN.2011 23:32:20



Test Mode :	Mode 3	Temperature :	25~27°C
Test Band :	802.11b	Relative Humidity :	45~48%
Test Channel :	11	Test Engineer :	Alan Liu

Conducted Spurious Emission Plot between 30MHz ~ 3 GHz

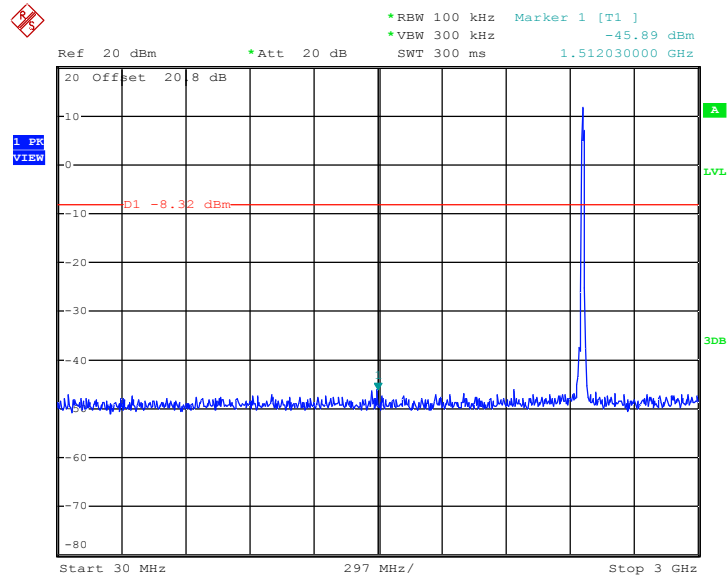

Date: 28.JAN.2011 23:44:32

Conducted Spurious Emission Plot between 3 GHz ~ 25 GHz

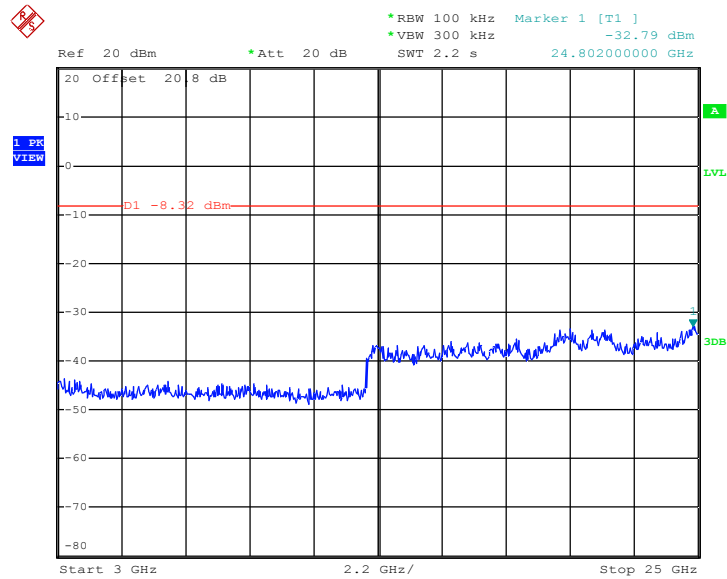

Date: 28.JAN.2011 23:44:49



Test Mode :	Mode 4	Temperature :	25~27°C
Test Band :	802.11g	Relative Humidity :	45~48%
Test Channel :	01	Test Engineer :	Alan Liu

Conducted Spurious Emission Plot between 30MHz ~ 3 GHz

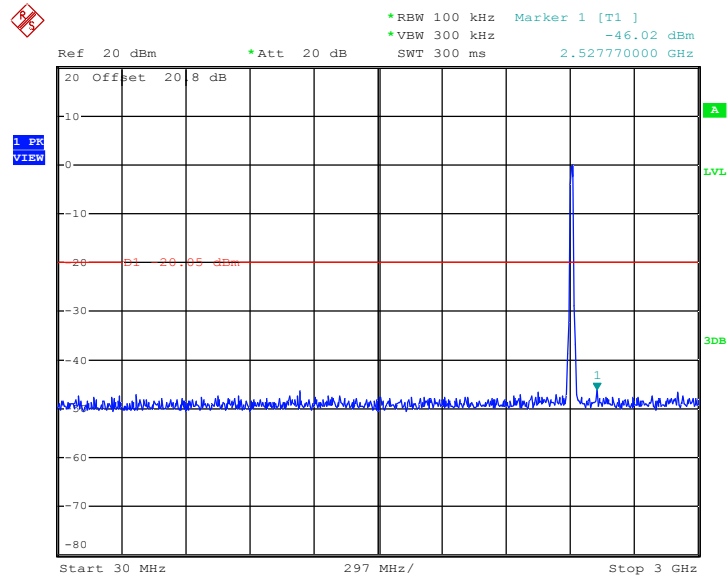

Date: 28.JAN.2011 23:58:32

Conducted Spurious Emission Plot between 3 GHz ~ 25 GHz

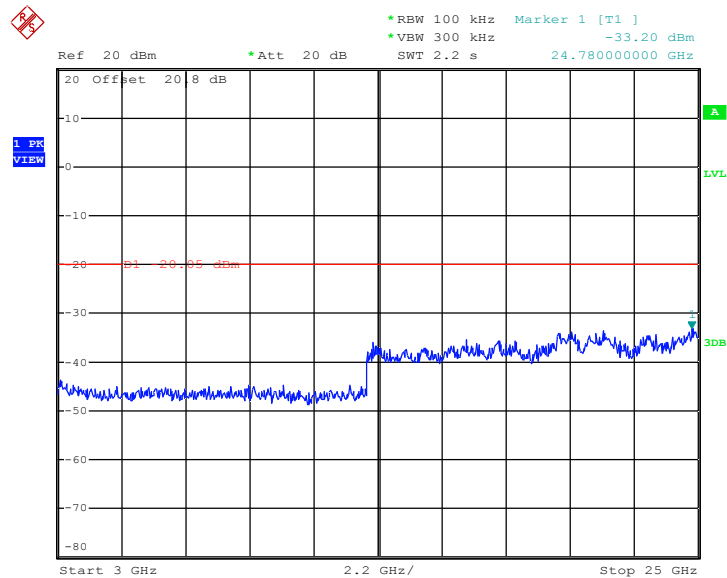

Date: 28.JAN.2011 23:58:49



Test Mode :	Mode 5	Temperature :	25~27
Test Band :	802.11g	Relative Humidity :	45~48
Test Channel :	06	Test Engineer :	Alan Liu

Conducted Spurious Emission Plot between 30MHz ~ 3 GHz

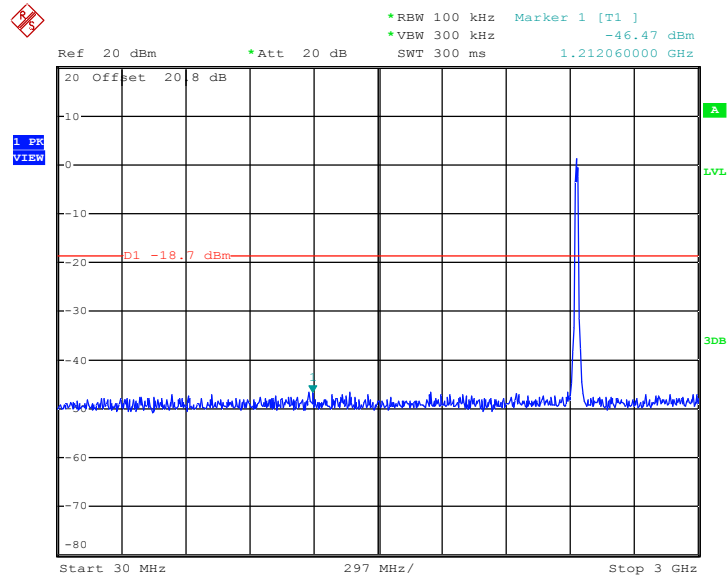

Date: 29.JAN.2011 00:10:10

Conducted Spurious Emission Plot between 3 GHz ~ 25 GHz

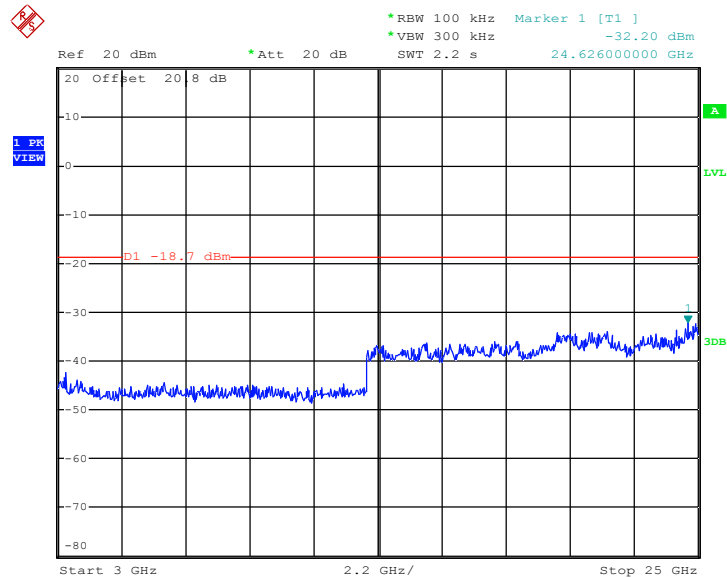

Date: 29.JAN.2011 00:10:27



Test Mode :	Mode 6	Temperature :	25~27°C
Test Band :	802.11g	Relative Humidity :	45~48%
Test Channel :	11	Test Engineer :	Alan Liu

Conducted Spurious Emission Plot between 30MHz ~ 3 GHz

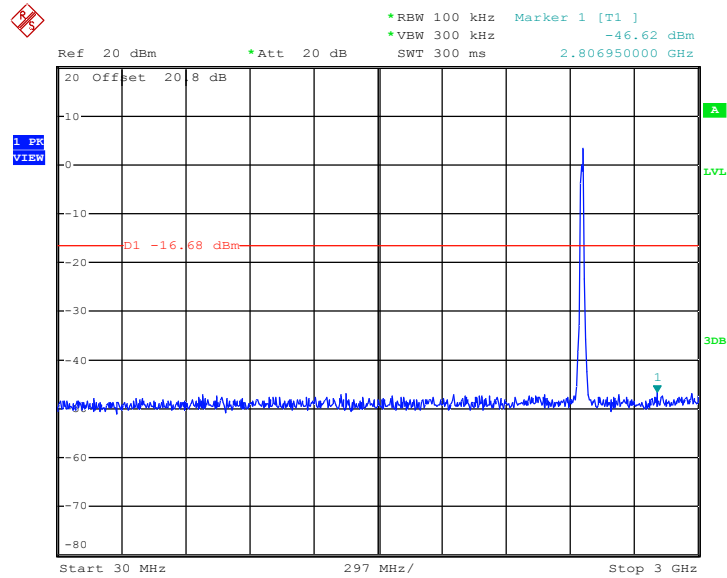

Date: 29.JAN.2011 00:22:50

Conducted Spurious Emission Plot between 3 GHz ~ 25 GHz

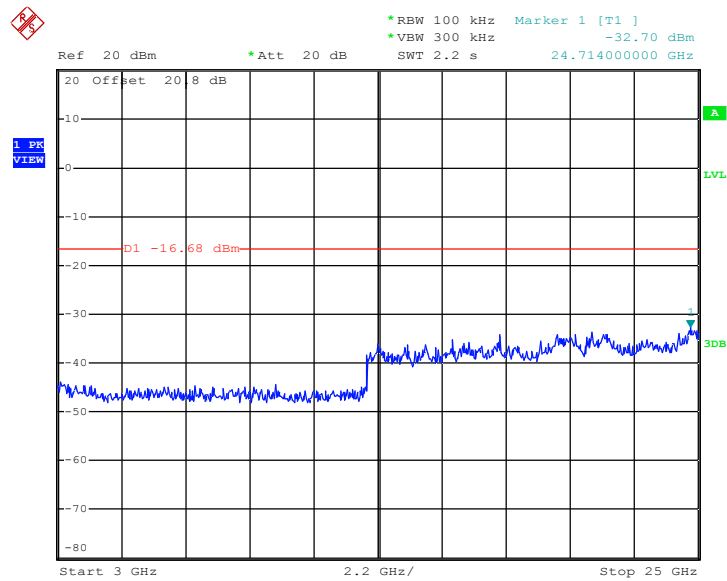

Date: 29.JAN.2011 00:23:07



Test Mode :	Mode 7	Temperature :	25~27°C
Test Band :	802.11n (BW 20MHz)	Relative Humidity :	45~48%
Test Channel :	01	Test Engineer :	Alan Liu

Conducted Spurious Emission Plot between 30MHz ~ 3 GHz

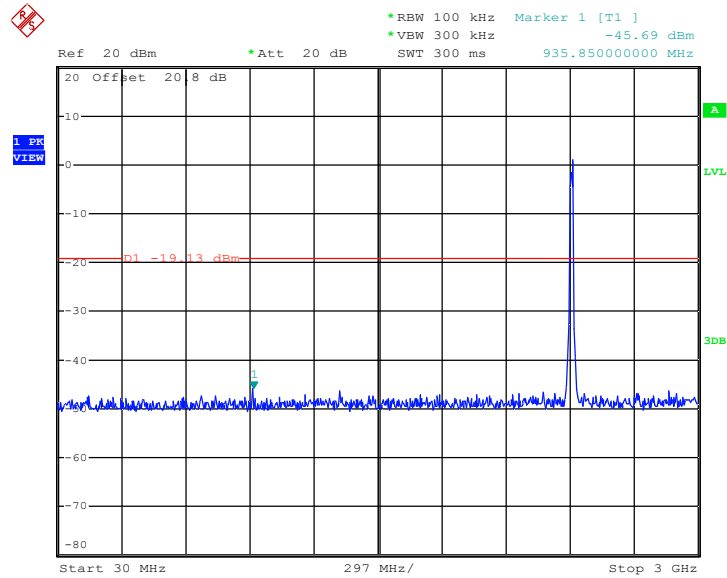

Date: 29.JAN.2011 00:37:33

Conducted Spurious Emission Plot between 3 GHz ~ 25 GHz

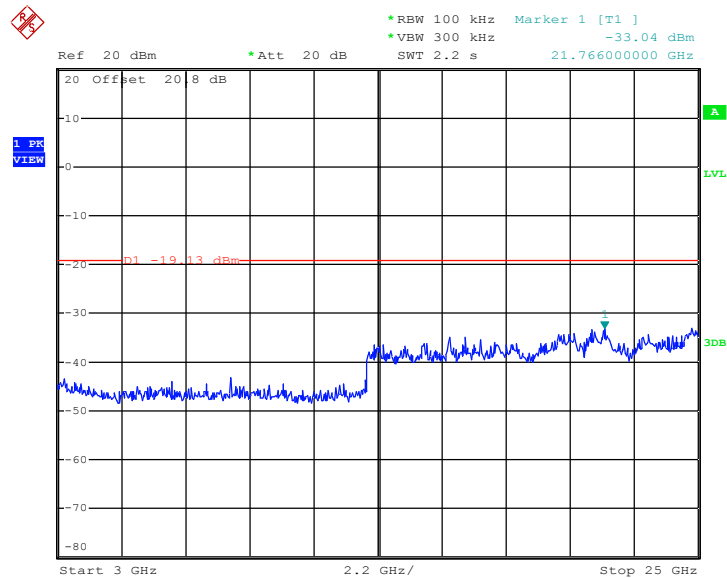

Date: 29.JAN.2011 00:37:51



Test Mode :	Mode 8	Temperature :	25~27°C
Test Band :	802.11n (BW 20MHz)	Relative Humidity :	45~48%
Test Channel :	06	Test Engineer :	Alan Liu

Conducted Spurious Emission Plot between 30MHz ~ 3 GHz

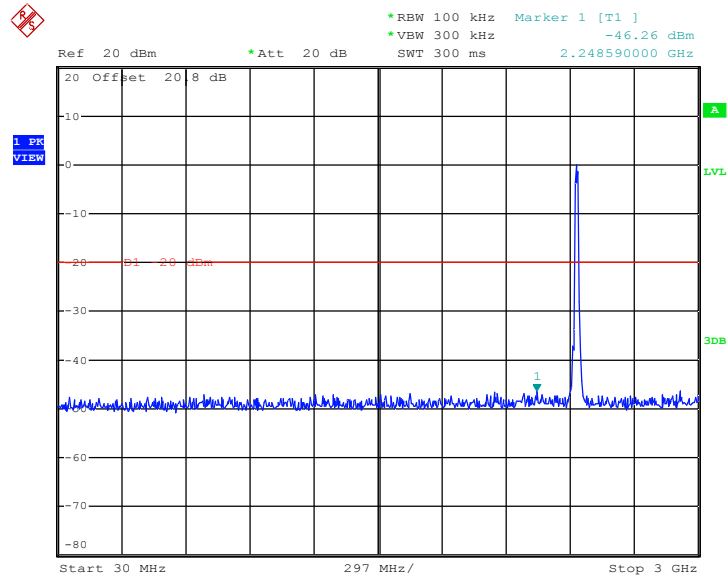

Date: 29.JAN.2011 00:49:36

Conducted Spurious Emission Plot between 3 GHz ~ 25 GHz

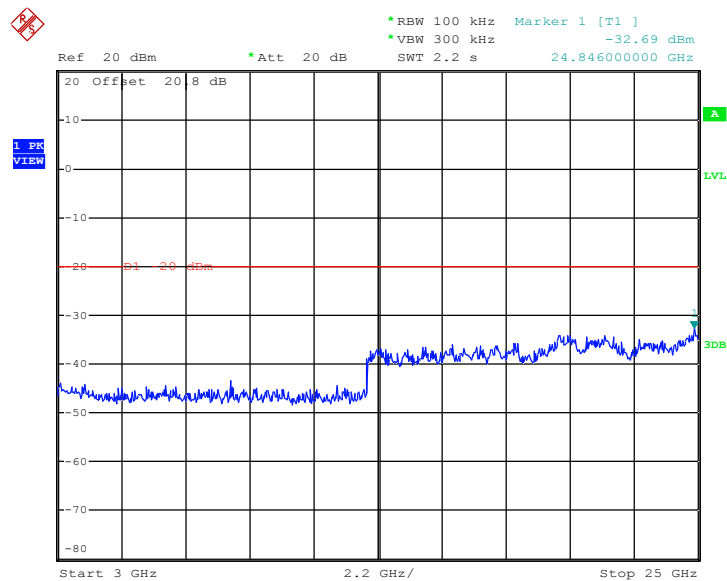

Date: 29.JAN.2011 00:49:53



Test Mode :	Mode 9	Temperature :	25~27°C
Test Band :	802.11n (BW 20MHz)	Relative Humidity :	45~48%
Test Channel :	11	Test Engineer :	Alan Liu

Conducted Spurious Emission Plot between 30MHz ~ 3 GHz

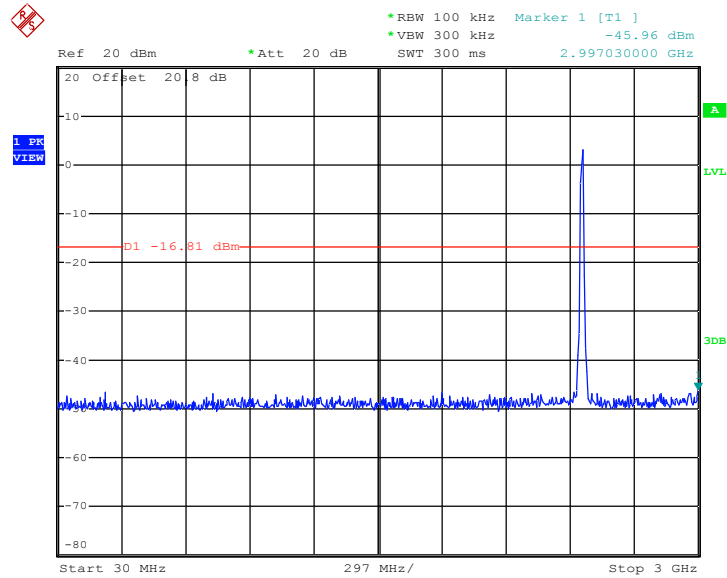

Date: 29.JAN.2011 01:01:24

Conducted Spurious Emission Plot between 3 GHz ~ 25 GHz

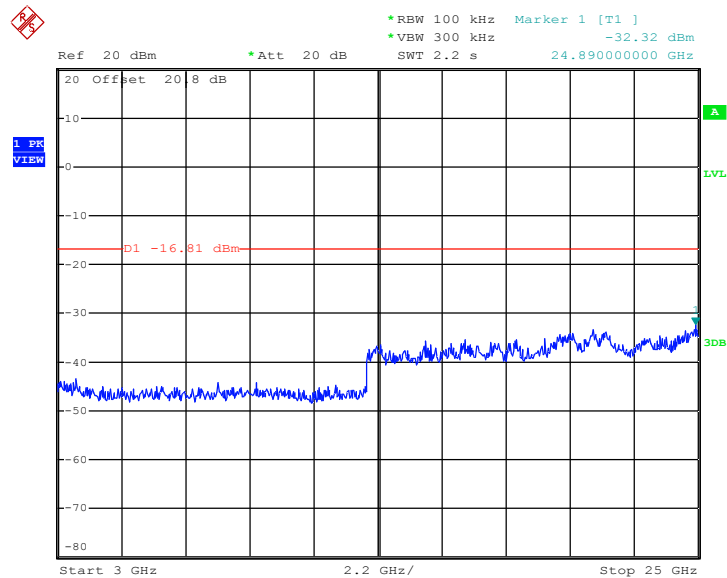

Date: 29.JAN.2011 01:01:41

3.5 Power Spectral Density Measurement

3.5.1 Limit of Power Spectral Density

The peak power spectral density shall not be greater than 8dBm in any 3kHz band at any time interval of continuous transmission.

3.5.2 Measuring Instruments

See list of measuring instruments of this test report.

3.5.3 Test Procedures

1. The test follows FCC KDB Publication No. 558074 (Measurement Guidelines of DTS).
2. The RF output of EUT was connected to the spectrum analyzer by a low loss cable.
3. Take the measured data from spectrum analyzer.

3.5.4 Test Setup

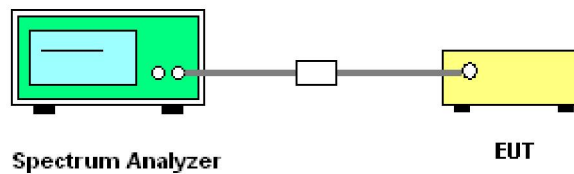



3.5.5 Test Result of Power Spectral Density

Test Mode :	Mode 1, 2, 3	Temperature :	25~27°C
Test Engineer :	Alan Liu	Relative Humidity :	45~48%

Channel	Frequency (MHz)	802.11b Measured PSD (dBm)	Max. Limits (dBm)	Pass/Fail
01	2412	-2.72	8	Pass
06	2437	-2.01	8	Pass
11	2462	-1.33	8	Pass

Mode 1 : PSD Plot on 802.11b Channel 01

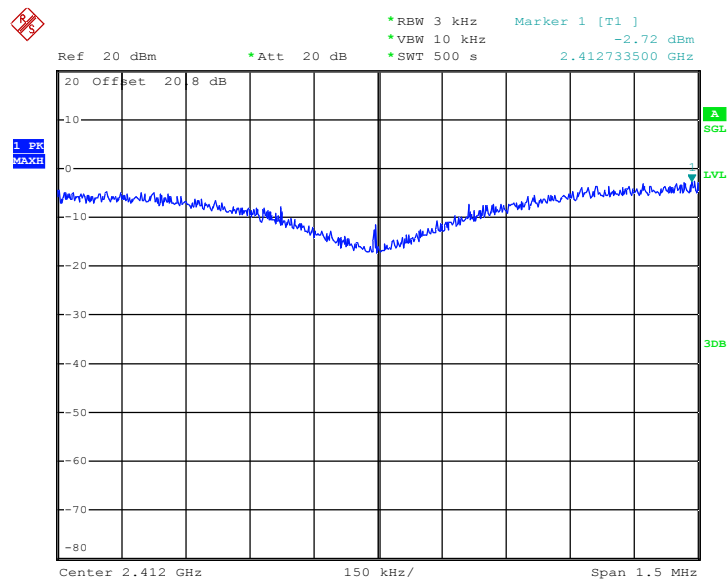

Date: 28.JAN.2011 23:20:20



Mode 2 : PSD Plot on 802.11b Channel 06

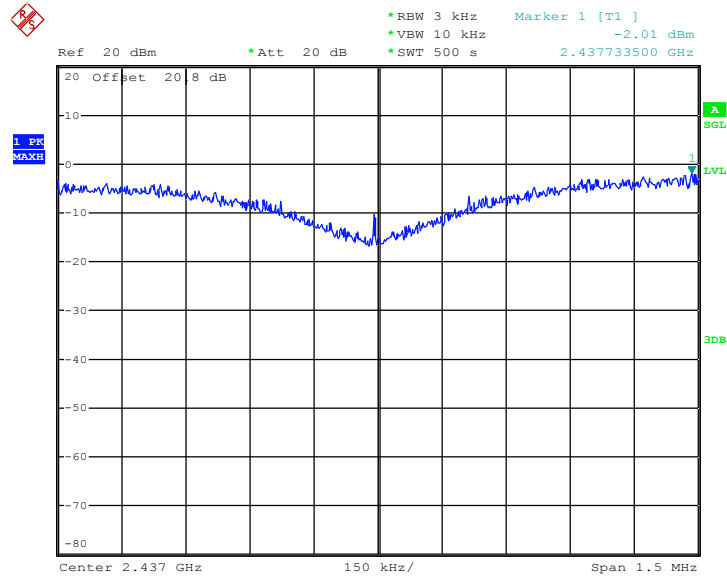

Date: 28.JAN.2011 23:31:42

Mode 3 : PSD Plot on 802.11b Channel 11

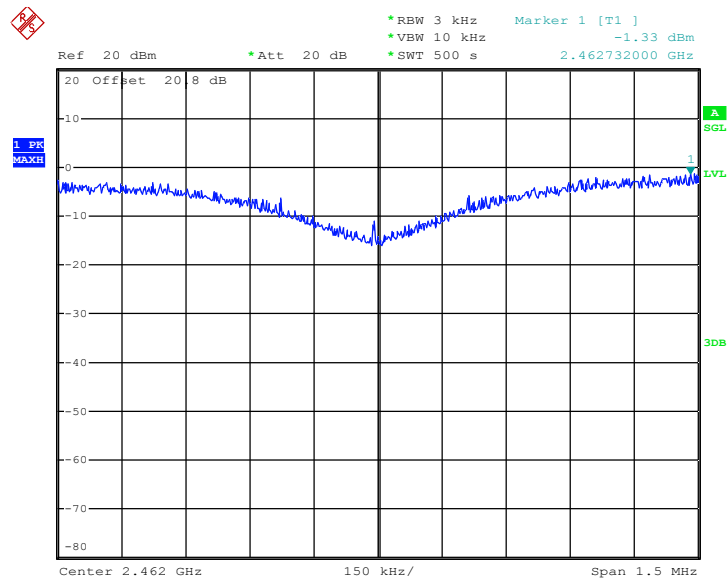

Date: 28.JAN.2011 23:44:11



Test Mode :	Mode 4, 5, 6	Temperature :	25~27°C
Test Engineer :	Alan Liu	Relative Humidity :	45~48%

Channel	Frequency (MHz)	802.11g Measured PSD (dBm)	Max. Limits (dBm)	Pass/Fail
01	2412	-10.84	8	Pass
06	2437	-10.74	8	Pass
11	2462	-9.70	8	Pass

Mode 4 : PSD Plot on 802.11g Channel 01

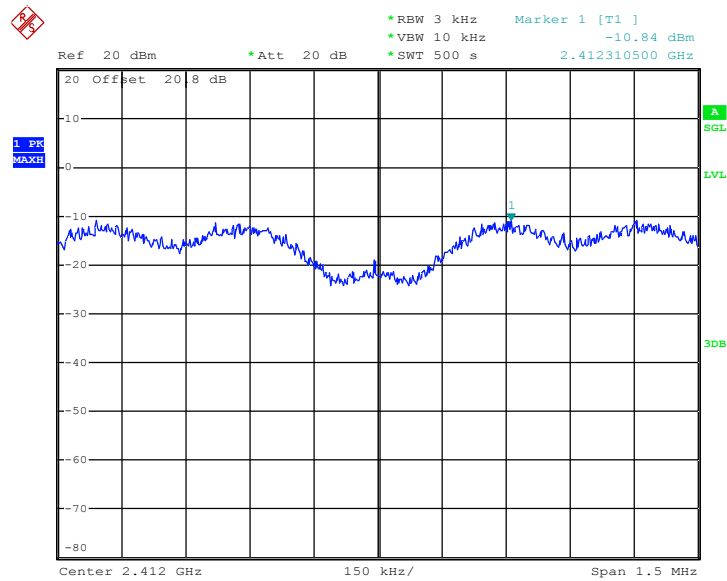

Date: 28.JAN.2011 23:58:11



Mode 5 : PSD Plot on 802.11g Channel 06

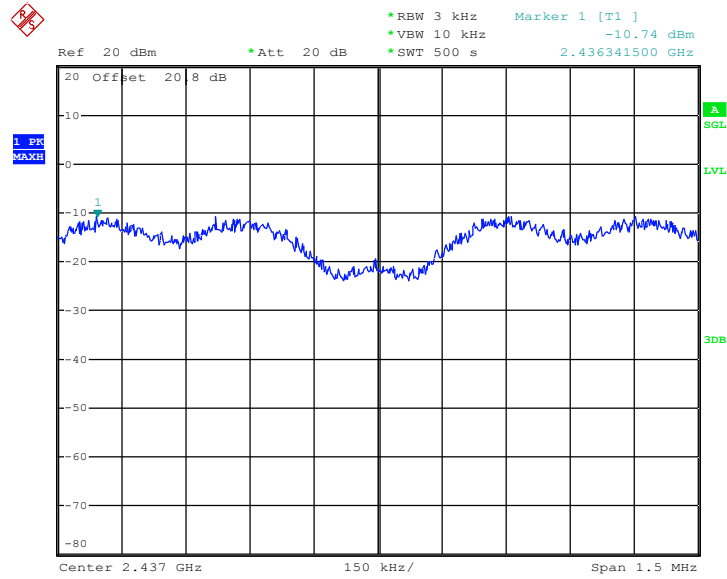

Date: 29.JAN.2011 00:09:49

Mode 6 : PSD Plot on 802.11g Channel 11

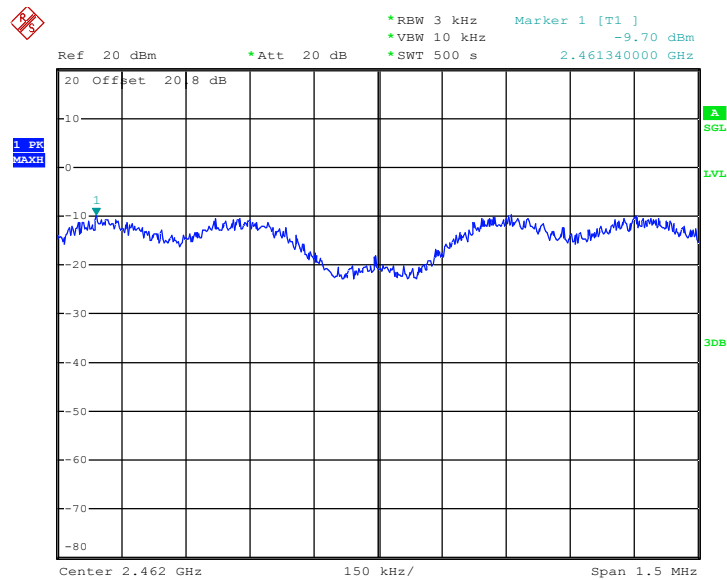

Date: 29.JAN.2011 00:22:29



Test Mode :	Mode 7, 8, 9	Temperature :	25~27°C
Test Engineer :	Alan Liu	Relative Humidity :	45~48%

Channel	Frequency (MHz)	802.11n (BW 20MHz) Measured PSD (dBm)	Max. Limits (dBm)	Pass/Fail
01	2412	-10.47	8	Pass
06	2437	-10.38	8	Pass
11	2462	-9.43	8	Pass

Mode 7 : PSD Plot on 802.11n (BW 20MHz) Channel 01

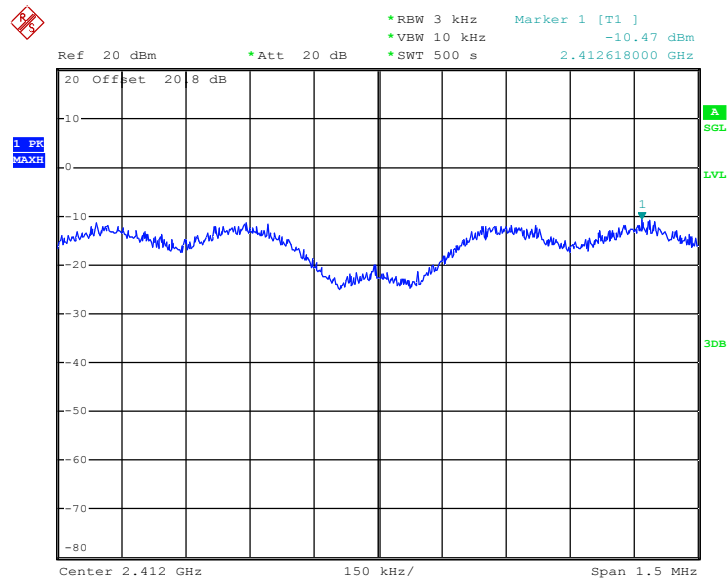

Date: 29.JAN.2011 00:37:12



Mode 8 : PSD Plot on 802.11n (BW 20MHz) Channel 06

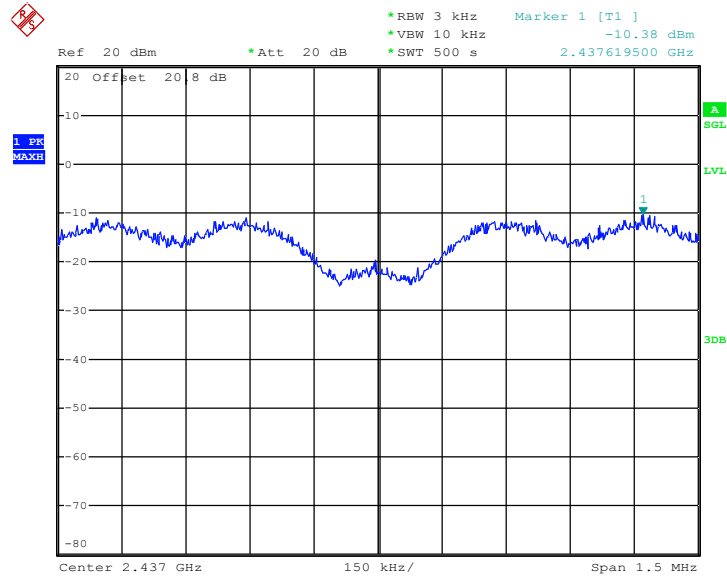

Date: 29.JAN.2011 00:49:15

Mode 9 : PSD Plot on 802.11n (BW 20MHz) Channel 11

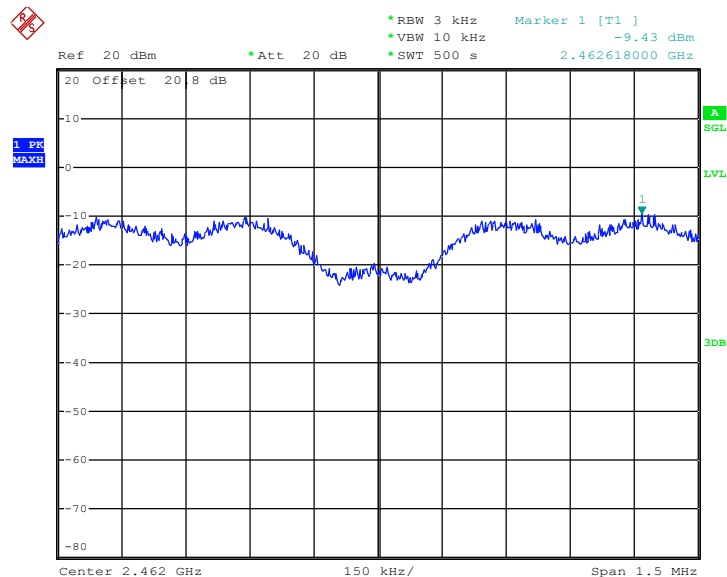

Date: 29.JAN.2011 01:01:03

3.6 AC Conducted Emission Measurement

3.6.1 Limit of AC Conducted Emission

For equipment that is designed to be connected to the public utility (AC) power line, the radio frequency voltage that is conducted back onto the AC power line on any frequency or frequencies within the band 150 kHz to 30 MHz shall not exceed the limits in the following table.

Frequency of Emission (MHz)	Conducted Limit (dBuV)	
	Quasi-Peak	Average
0.15-0.5	66 to 56*	56 to 46*
0.5-5	56	46
5-30	60	50

*Decreases with the logarithm of the frequency.

3.6.2 Measuring Instruments

See list of measuring instruments of this test report.

3.6.3 Test Procedures

1. The testing follows the guidelines in ANSI C63.4-2003.
2. The EUT was placed 0.4 meter from the conducting wall of the shielding room, and it was kept at least 80 centimeters from any other grounded conducting surface.
3. Connect EUT to the power mains through a line impedance stabilization network (LISN).
4. All the support units are connecting to the other LISN.
5. The LISN provides 50 ohm coupling impedance for the measuring instrument.
6. The FCC states that a 50 ohm, 50 microhenry LISN should be used.
7. Both sides of AC line were checked for maximum conducted interference.
8. The frequency range from 150 kHz to 30 MHz was searched.
9. Set the test-receiver system to Peak Detect Function and specified bandwidth with Maximum Hold Mode.

3.6.4 Test Setup

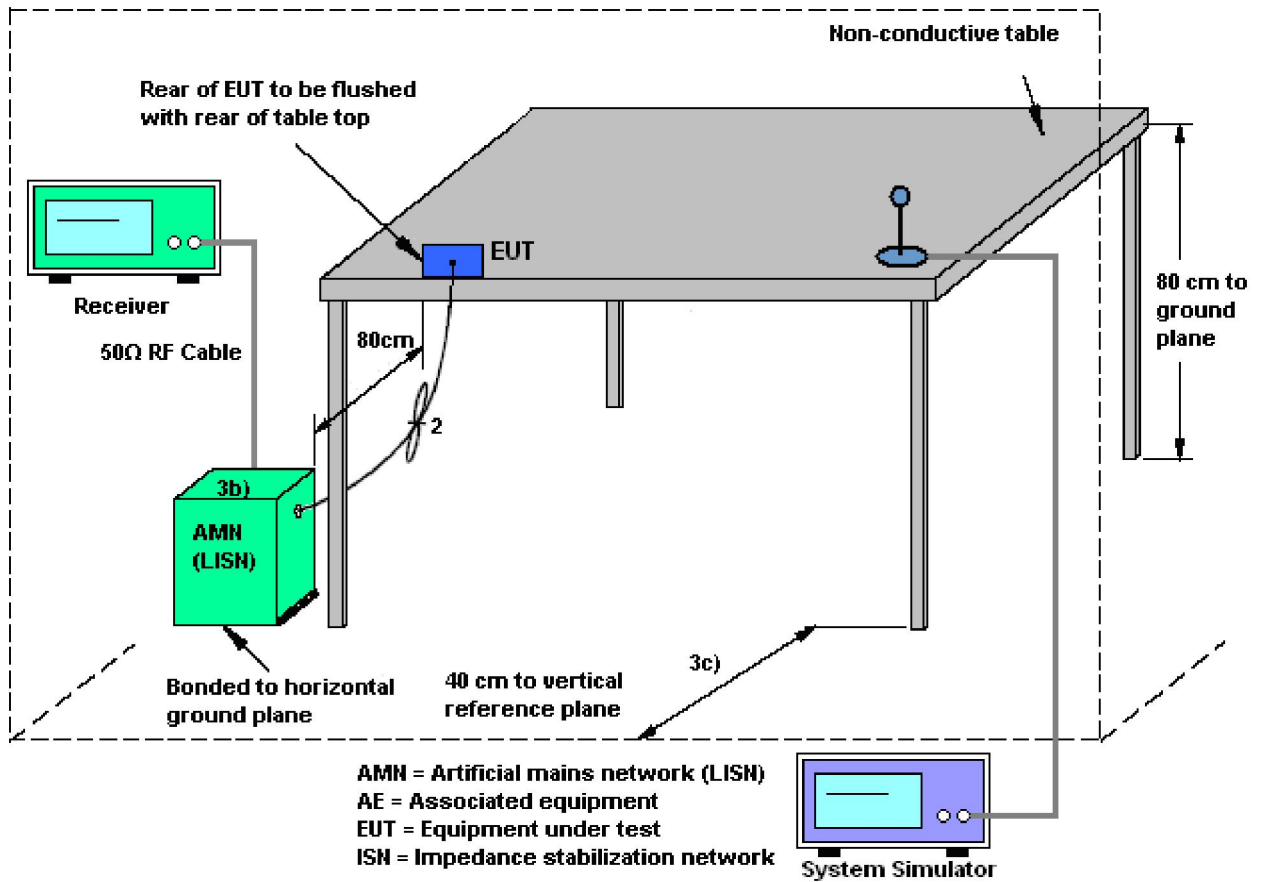

3.6.5 Test Result of AC Conducted Emission

Test Mode :	Mode 1	Temperature :	20~22°C
Test Engineer :	Novic Chiang	Relative Humidity :	40~42%
Test Voltage :	120Vac / 60Hz	Phase :	Line
Function Type :	GSM850 Idle + Bluetooth Link + WLAN Link + GPS Rx + Earphone 1 + Adapter		
Remark :	All emissions not reported here are more than 10 dB below the prescribed limit.		

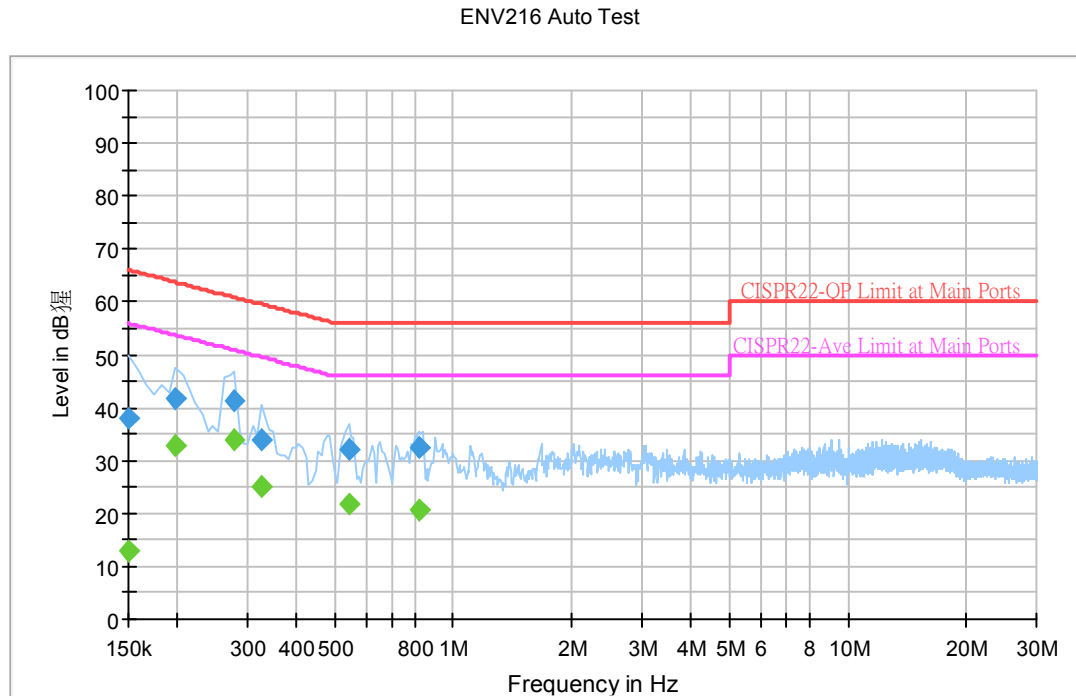

Final Result 1

Frequency	QuasiPe	Filter	Line	Corr.	Margin	Limit
0.150000	38.0	Off	L1	19.4	28.0	66.0
0.198000	41.6	Off	L1	19.3	22.1	63.7
0.278000	41.4	Off	L1	19.3	19.5	60.9
0.326000	34.0	Off	L1	19.3	25.6	59.6
0.542000	32.0	Off	L1	19.3	24.0	56.0
0.822000	32.3	Off	L1	19.5	23.7	56.0

Final Result 2

Frequency	Average	Filter	Line	Corr.	Margin	Limit
0.150000	13.0	Off	L1	19.4	43.0	56.0
0.198000	32.8	Off	L1	19.3	20.9	53.7
0.278000	33.8	Off	L1	19.3	17.1	50.9
0.326000	25.3	Off	L1	19.3	24.3	49.6
0.542000	21.9	Off	L1	19.3	24.1	46.0
0.822000	20.7	Off	L1	19.5	25.3	46.0



Test Mode :	Mode 1	Temperature :	20~22°C
Test Engineer :	Novic Chiang	Relative Humidity :	40~42%
Test Voltage :	120Vac / 60Hz	Phase :	Neutral
Function Type :	GSM850 Idle + Bluetooth Link + WLAN Link + GPS Rx + Earphone 1 + Adapter		
Remark :	All emissions not reported here are more than 10 dB below the prescribed limit.		

ENV216 Auto Test

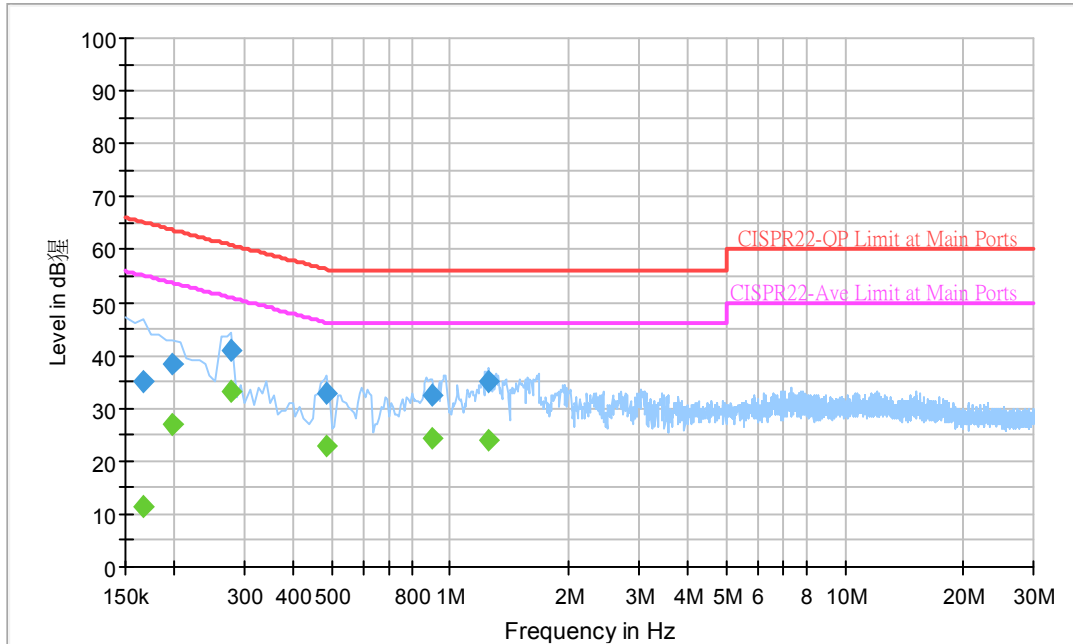

Final Result 1

Frequency	QuasiPe	Filter	Line	Corr.	Margin	Limit
0.166000	34.9	Off	N	19.3	30.3	65.2
0.198000	38.4	Off	N	19.3	25.3	63.7
0.278000	40.9	Off	N	19.3	20.0	60.9
0.486000	33.0	Off	N	19.4	23.2	56.2
0.894000	32.4	Off	N	19.4	23.6	56.0
1.254000	34.9	Off	N	19.5	21.1	56.0

Final Result 2

Frequency	Average	Filter	Line	Corr.	Margin	Limit
0.166000	11.4	Off	N	19.3	43.8	55.2
0.198000	26.8	Off	N	19.3	26.9	53.7
0.278000	33.2	Off	N	19.3	17.7	50.9
0.486000	22.9	Off	N	19.4	23.3	46.2
0.894000	24.5	Off	N	19.4	21.5	46.0
1.254000	24.0	Off	N	19.5	22.0	46.0

3.7 Radiated Emission Measurement

3.7.1 Limit of Radiated Emission

In any 100 kHz bandwidth outside the intentional radiator frequency band, all harmonics/spurious must be at least 20 dB below the highest emission level within the authorized band. If the output power of this device was measured by spectrum analyzer, the attenuation under this paragraph shall be 30 dB instead of 20 dB. In addition, radiated emissions which fall in the restricted bands must also comply with the FCC section 15.209 limits as below.

Frequency (MHz)	Field Strength (microvolts/meter)	Measurement Distance (meters)
0.009 – 0.490	2400/F(kHz)	300
0.490 – 1.705	24000/F(kHz)	30
1.705 – 30.0	30	30
30 – 88	100	3
88 – 216	150	3
216 - 960	200	3
Above 960	500	3

3.7.2 Measuring Instruments

See list of measuring instruments of this test report.

3.7.3 Test Procedures

- The testing follows the guidelines in FCC KDB Publication No. 558074 (Measurement Guidelines of DTS).
- Use the following spectrum analyzer settings:
 - Span = wide enough to fully capture the emission being measured; RBW = 1 MHz for $f \geq 1$ GHz, 100 kHz for $f < 1$ GHz; VBW \geq RBW; Sweep = auto; Detector function = peak; Trace = max hold.
 - Above 18 GHz shall be extrapolated to the specified distance using an extrapolation factor of 20 dB/decade from 3m to 1m.
Distance extrapolation factor = $20 \log(\text{specific distance [3m]} / \text{test distance [1m]})$ (dB)
- Follow the guidelines in ANSI C63.4-2003 with respect to maximizing the emission by rotating the EUT, measuring the emission for three EUT orthogonal planes, and adjusting the measurement antenna height and polarization. A pre-amp and a high pass filter are used for this test in order to get the good signal level.

3.7.4 Test Setup

For radiated emissions below 30MHz

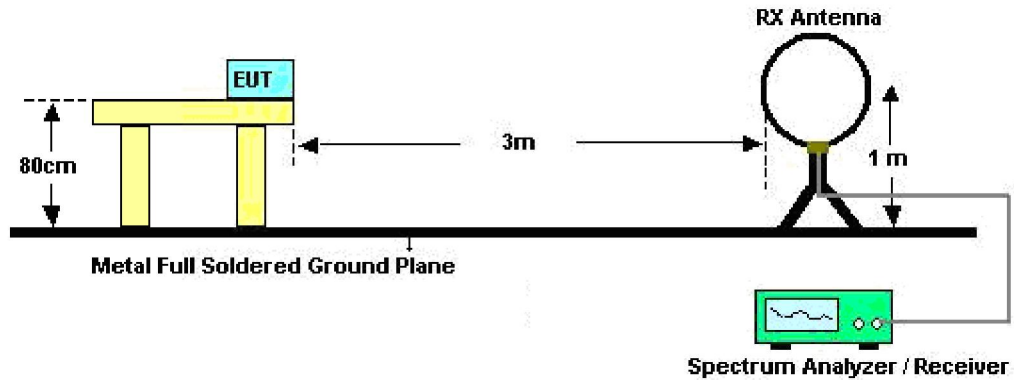

For radiated emissions above 30MHz

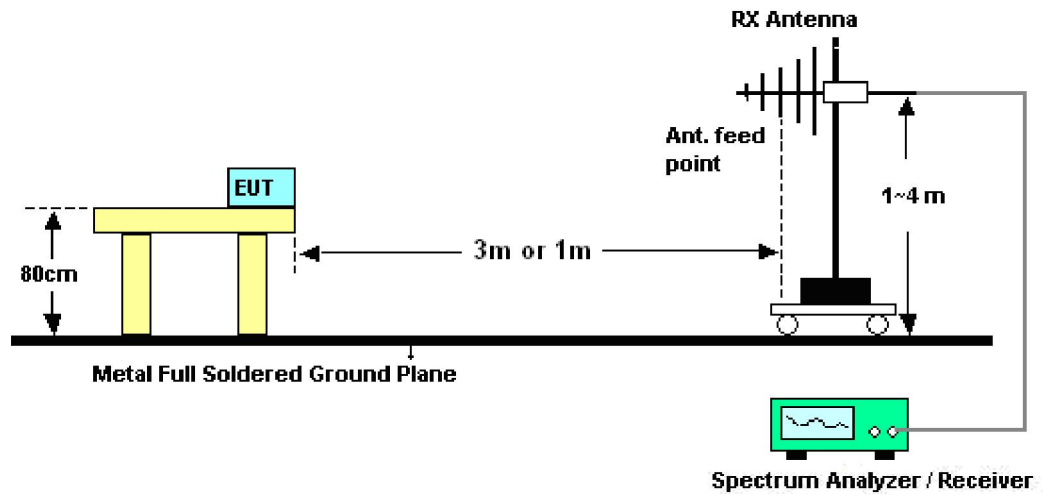



3.7.5 Test Results of Radiated Emissions (9 kHz ~ 30 MHz)

Test Engineer :	David Yang	Temperature :	21~22°C	
		Relative Humidity :	47~49%	
Frequency (MHz)	Level (dBuV)	Over Limit (dB)	Limit Line (dBuV)	Remark
-	-	-	-	See Note

Note:

The amplitude of spurious emissions that are attenuated by more than 20dB below the permissible value has no need to be reported.

Distance extrapolation factor = $40 \log(\text{specific distance} / \text{test distance})$ (dB);

Limit line = specific limits (dBuV) + distance extrapolation factor.



3.7.6 Test Result of Radiated Emission (30 MHz ~ 10th Harmonic)

Test Mode :	Mode 1	Temperature :	21~22°C
Test Channel :	01	Relative Humidity :	47~49%
Test Engineer :	David Yang	Polarization :	Horizontal
Remark :	2412 MHz is Fundamental Signals which can be ignored.		

Frequency (MHz)	Level (dBuV/m)	Over Limit (dB)	Limit Line (dBuV/m)	Read Level (dBuV)	Antenna Factor (dB)	Cable Loss (dB)	Preamp Factor (dB)	Ant Pos (cm)	Table Pos (deg)	Remark
32.7	18.89	-21.11	40	34	15.8	0.56	31.47	-	-	Peak
144.21	29.65	-13.85	43.5	48.63	11.37	1.2	31.55	-	-	Peak
288.66	24.45	-21.55	46	40.79	13.29	1.69	31.32	-	-	Peak
335.7	31.38	-14.62	46	46.24	14.57	1.87	31.3	-	-	Peak
416.2	27.5	-18.5	46	39.63	16.83	2.2	31.16	-	-	Peak
897.8	32.75	-13.25	46	36.5	23.61	3.34	30.7	133	187	Peak
2389.99	56.89	-17.11	74	52.53	32.18	6.03	33.85	141	360	Peak
2389.99	44.87	-9.13	54	40.51	32.18	6.03	33.85	141	360	Average
2412	111.1	-	-	106.7	32.2	6.07	33.87	141	360	Peak
2412	107.18	-	-	102.78	32.2	6.07	33.87	141	360	Average
2484	37.68	-16.32	54	33.12	32.28	6.18	33.9	141	360	Average
2484	50.21	-23.79	74	45.65	32.28	6.18	33.9	141	360	Peak
7236	49.11	-24.89	74	60.58	35.51	10.03	57.01	100	0	Peak



Test Mode :	Mode 1	Temperature :	21~22°C
Test Channel :	01	Relative Humidity :	47~49%
Test Engineer :	David Yang	Polarization :	Vertical
Remark :	2412 MHz is Fundamental Signals which can be ignored.		

Frequency (MHz)	Level (dBuV/m)	Over Limit (dB)	Limit Line (dBuV/m)	Read Level (dBuV)	Antenna Factor (dB)	Cable Loss (dB)	Preamp Factor (dB)	Ant Pos (cm)	Table Pos (deg)	Remark
50.25	27.3	-12.7	40	49.86	8.28	0.7	31.54	-	-	Peak
139.62	27.99	-15.51	43.5	46.74	11.6	1.2	31.55	-	-	Peak
272.73	26.3	-19.7	46	42.99	13.03	1.64	31.36	-	-	Peak
383.3	24.67	-21.33	46	37.74	16.05	2.11	31.23	-	-	Peak
576.5	22.91	-23.09	46	31.84	19.4	2.62	30.95	-	-	Peak
897.8	35.19	-10.81	46	38.94	23.61	3.34	30.7	115	187	Peak
2389.42	56.45	-17.55	74	52.09	32.18	6.03	33.85	100	170	Peak
2389.42	44.23	-9.77	54	39.87	32.18	6.03	33.85	100	170	Average
2412	110.49	-	-	106.09	32.2	6.07	33.87	100	170	Peak
2412	106.08	-	-	101.68	32.2	6.07	33.87	100	170	Average
2486	35.29	-18.71	54	30.73	32.28	6.18	33.9	100	170	Average
2486	47.1	-26.9	74	42.54	32.28	6.18	33.9	100	170	Peak
7236	50.63	-23.37	74	62.1	35.51	10.03	57.01	100	0	Peak



Test Mode :	Mode 2	Temperature :	21~22°C
Test Channel :	06	Relative Humidity :	47~49%
Test Engineer :	David Yang	Polarization :	Horizontal
Remark :	2437 MHz is Fundamental Signals which can be ignored.		

Frequency (MHz)	Level (dBuV/m)	Over Limit (dB)	Limit Line (dBuV/m)	Read Level (dBuV)	Antenna Factor (dB)	Cable Loss (dB)	Preamp Factor (dB)	Ant Pos (cm)	Table Pos (deg)	Remark
31.89	18.33	-21.67	40	33.2	16.04	0.55	31.46	-	-	Peak
143.94	28.92	-14.58	43.5	47.85	11.42	1.2	31.55	124	188	Peak
288.66	26.38	-19.62	46	42.72	13.29	1.69	31.32	-	-	Peak
335.7	30.96	-15.04	46	45.82	14.57	1.87	31.3	-	-	Peak
383.3	29.02	-16.98	46	42.09	16.05	2.11	31.23	-	-	Peak
480.6	27.32	-18.68	46	38.09	17.91	2.38	31.06	-	-	Peak
2388	47.9	-26.1	74	43.54	32.18	6.03	33.85	139	0	Peak
2388	36.54	-17.46	54	32.18	32.18	6.03	33.85	139	0	Average
2437	110.65	-	-	106.18	32.24	6.11	33.88	139	0	Peak
2437	106.48	-	-	102.01	32.24	6.11	33.88	139	0	Average
2486	49.05	-24.95	74	44.49	32.28	6.18	33.9	139	0	Peak
2486	37.17	-16.83	54	32.61	32.28	6.18	33.9	139	0	Average
7311	52.26	-21.74	74	63.73	35.45	10.06	56.98	140	268	Peak
7311	48.62	-5.38	54	60.09	35.45	10.06	56.98	140	268	Average



Test Mode :	Mode 2	Temperature :	21~22°C
Test Channel :	06	Relative Humidity :	47~49%
Test Engineer :	David Yang	Polarization :	Vertical
Remark :	2437 MHz is Fundamental Signals which can be ignored.		

Frequency (MHz)	Level (dBuV/m)	Over Limit (dB)	Limit Line (dBuV/m)	Read Level (dBuV)	Antenna Factor (dB)	Cable Loss (dB)	Preamp Factor (dB)	Ant Pos (cm)	Table Pos (deg)	Remark
49.98	27.15	-12.85	40	49.71	8.28	0.7	31.54	-	-	Peak
143.94	24.16	-19.34	43.5	43.09	11.42	1.2	31.55	-	-	Peak
233.85	28.53	-17.47	46	46.96	11.5	1.5	31.43	-	-	Peak
383.3	25.06	-20.94	46	38.13	16.05	2.11	31.23	-	-	Peak
576.5	24.01	-21.99	46	32.94	19.4	2.62	30.95	-	-	Peak
897.8	34.56	-11.44	46	38.31	23.61	3.34	30.7	132	174	Peak
2390	49.36	-24.64	74	45	32.18	6.03	33.85	100	190	Peak
2390	37.31	-16.69	54	32.95	32.18	6.03	33.85	100	190	Average
2437	109.75	-	-	105.28	32.24	6.11	33.88	100	190	Peak
2437	105.77	-	-	101.3	32.24	6.11	33.88	100	190	Average
2484	49.54	-24.46	74	44.98	32.28	6.18	33.9	100	190	Peak
2484	36.6	-17.4	54	32.04	32.28	6.18	33.9	100	190	Average
7311	52.84	-21.16	74	64.31	35.45	10.06	56.98	110	322	Peak
7311	44.94	-9.06	54	56.41	35.45	10.06	56.98	110	322	Average



Test Mode :	Mode 3	Temperature :	21~22°C
Test Channel :	11	Relative Humidity :	47~49%
Test Engineer :	David Yang	Polarization :	Horizontal
Remark :	2462 MHz is Fundamental Signals which can be ignored.		

Frequency (MHz)	Level (dBuV/m)	Over Limit (dB)	Limit Line (dBuV/m)	Read Level (dBuV)	Antenna Factor (dB)	Cable Loss (dB)	Preamp Factor (dB)	Ant Pos (cm)	Table Pos (deg)	Remark
31.89	18.44	-21.56	40	33.31	16.04	0.55	31.46	-	-	Peak
143.94	28.97	-14.53	43.5	47.9	11.42	1.2	31.55	115	49	Peak
240.33	24.22	-21.78	46	42.13	11.98	1.53	31.42	-	-	Peak
335.7	31.24	-14.76	46	46.1	14.57	1.87	31.3	-	-	Peak
383.3	28.36	-17.64	46	41.43	16.05	2.11	31.23	-	-	Peak
480.6	26.64	-19.36	46	37.41	17.91	2.38	31.06	-	-	Peak
2380	47.65	-26.35	74	43.31	32.16	6.03	33.85	137	360	Peak
2380	35.23	-18.77	54	30.89	32.16	6.03	33.85	137	360	Average
2462	106.53	-	-	102.02	32.26	6.14	33.89	137	360	Average
2462	110.53	-	-	106.02	32.26	6.14	33.89	137	360	Peak
2483.5	55.98	-18.02	74	51.42	32.28	6.18	33.9	137	360	Peak
2483.5	45.36	-8.64	54	40.8	32.28	6.18	33.9	137	360	Average
7386	52.87	-21.13	74	64.32	35.38	10.1	56.93	146	269	Peak
7386	48.54	-5.46	54	59.99	35.38	10.1	56.93	146	269	Average



Test Mode :	Mode 3	Temperature :	21~22°C
Test Channel :	11	Relative Humidity :	47~49%
Test Engineer :	David Yang	Polarization :	Vertical
Remark :	2462 MHz is Fundamental Signals which can be ignored.		

Frequency (MHz)	Level (dBuV/m)	Over Limit (dB)	Limit Line (dBuV/m)	Read Level (dBuV)	Antenna Factor (dB)	Cable Loss (dB)	Preamp Factor (dB)	Ant Pos (cm)	Table Pos (deg)	Remark
49.17	26.79	-13.21	40	48.95	8.68	0.69	31.53	100	255	Peak
226.02	25.87	-20.13	46	44.91	10.95	1.46	31.45	-	-	Peak
291.9	26	-20	46	42.27	13.34	1.71	31.32	-	-	Peak
383.3	24.92	-21.08	46	37.99	16.05	2.11	31.23	-	-	Peak
576.5	22.95	-23.05	46	31.88	19.4	2.62	30.95	-	-	Peak
691.3	22.6	-23.4	46	29.72	20.79	2.92	30.83	-	-	Peak
2390	48.71	-25.29	74	44.35	32.18	6.03	33.85	100	191	Peak
2390	36.39	-17.61	54	32.03	32.18	6.03	33.85	100	191	Average
2462	104.85	-	-	100.34	32.26	6.14	33.89	100	191	Average
2462	108.87	-	-	104.36	32.26	6.14	33.89	100	191	Peak
2483.5	56.72	-17.28	74	52.16	32.28	6.18	33.9	100	191	Peak
2483.5	46.18	-7.82	54	41.62	32.28	6.18	33.9	100	191	Average
7386	51.34	-22.66	74	62.79	35.38	10.1	56.93	168	339	Peak
7386	45.41	-8.59	54	56.86	35.38	10.1	56.93	168	339	Average



Test Mode :	Mode 4	Temperature :	21~22°C
Test Channel :	01	Relative Humidity :	47~49%
Test Engineer :	David Yang	Polarization :	Horizontal
Remark :	2412 MHz is Fundamental Signals which can be ignored.		

Frequency (MHz)	Level (dBuV/m)	Over Limit (dB)	Limit Line (dBuV/m)	Read Level (dBuV)	Antenna Factor (dB)	Cable Loss (dB)	Preamp Factor (dB)	Ant Pos (cm)	Table Pos (deg)	Remark
48.9	22.68	-17.32	40	44.45	9.08	0.68	31.53	-	-	Peak
143.94	28.95	-14.55	43.5	47.88	11.42	1.2	31.55	105	122	Peak
288.66	24.64	-21.36	46	40.98	13.29	1.69	31.32	-	-	Peak
335.7	31.39	-14.61	46	46.25	14.57	1.87	31.3	-	-	Peak
383.3	28.46	-17.54	46	41.53	16.05	2.11	31.23	-	-	Peak
480.6	26.48	-19.52	46	37.25	17.91	2.38	31.06	-	-	Peak
2389.61	68.89	-5.11	74	64.53	32.18	6.03	33.85	148	360	Peak
2389.61	48.51	-5.49	54	44.15	32.18	6.03	33.85	148	360	Average
2412	108.76	-	-	104.36	32.2	6.07	33.87	148	360	Peak
2412	94.77	-	-	90.37	32.2	6.07	33.87	148	360	Average
2500	33.56	-20.44	54	28.98	32.3	6.18	33.9	148	360	Average
2500	45.37	-28.63	74	40.79	32.3	6.18	33.9	148	360	Peak



Test Mode :	Mode 4	Temperature :	21~22°C
Test Channel :	01	Relative Humidity :	47~49%
Test Engineer :	David Yang	Polarization :	Vertical
Remark :	2412 MHz is Fundamental Signals which can be ignored.		

Frequency (MHz)	Level (dBuV/m)	Over Limit (dB)	Limit Line (dBuV/m)	Read Level (dBuV)	Antenna Factor (dB)	Cable Loss (dB)	Preamp Factor (dB)	Ant Pos (cm)	Table Pos (deg)	Remark
49.98	27.26	-12.74	40	49.82	8.28	0.7	31.54	130	358	Peak
138.54	26.05	-17.45	43.5	44.8	11.6	1.2	31.55	-	-	Peak
264.9	28.14	-17.86	46	45.02	12.9	1.62	31.4	-	-	Peak
383.3	24.47	-21.53	46	37.54	16.05	2.11	31.23	-	-	Peak
480.6	22.65	-23.35	46	33.42	17.91	2.38	31.06	-	-	Peak
673.8	23.6	-22.4	46	30.96	20.6	2.89	30.85	-	-	Peak
2389.99	68.65	-5.35	74	64.29	32.18	6.03	33.85	100	23	Peak
2389.99	47.13	-6.87	54	42.77	32.18	6.03	33.85	100	23	Average
2412	106.35	-	-	101.95	32.2	6.07	33.87	100	23	Peak
2412	93.11	-	-	88.71	32.2	6.07	33.87	100	23	Average
2494	33.59	-20.41	54	29.01	32.3	6.18	33.9	100	23	Average
2494	46.08	-27.92	74	41.5	32.3	6.18	33.9	100	23	Peak



Test Mode :	Mode 5	Temperature :	21~22°C
Test Channel :	06	Relative Humidity :	47~49%
Test Engineer :	David Yang	Polarization :	Horizontal
Remark :	2437 MHz is Fundamental Signals which can be ignored.		

Frequency (MHz)	Level (dBuV/m)	Over Limit (dB)	Limit Line (dBuV/m)	Read Level (dBuV)	Antenna Factor (dB)	Cable Loss (dB)	Preamp Factor (dB)	Ant Pos (cm)	Table Pos (deg)	Remark
32.7	19.08	-20.92	40	34.19	15.8	0.56	31.47	-	-	Peak
144.21	29.72	-13.78	43.5	48.7	11.37	1.2	31.55	131	110	Peak
288.66	24.93	-21.07	46	41.27	13.29	1.69	31.32	-	-	Peak
335.7	31.58	-14.42	46	46.44	14.57	1.87	31.3	-	-	Peak
383.3	29.78	-16.22	46	42.85	16.05	2.11	31.23	-	-	Peak
480.6	26.47	-19.53	46	37.24	17.91	2.38	31.06	-	-	Peak
2390	52.42	-21.58	74	48.06	32.18	6.03	33.85	113	358	Peak
2390	36.48	-17.52	54	32.12	32.18	6.03	33.85	113	358	Average
2437	108.12	-	-	103.65	32.24	6.11	33.88	113	358	Peak
2437	94.37	-	-	89.9	32.24	6.11	33.88	113	358	Average
2484	51.72	-22.28	74	47.16	32.28	6.18	33.9	113	358	Peak
2484	35.15	-18.85	54	30.59	32.28	6.18	33.9	113	358	Average



Test Mode :	Mode 5	Temperature :	21~22°C
Test Channel :	06	Relative Humidity :	47~49%
Test Engineer :	David Yang	Polarization :	Vertical
Remark :	2437 MHz is Fundamental Signals which can be ignored.		

Frequency (MHz)	Level (dBuV/m)	Over Limit (dB)	Limit Line (dBuV/m)	Read Level (dBuV)	Antenna Factor (dB)	Cable Loss (dB)	Preamp Factor (dB)	Ant Pos (cm)	Table Pos (deg)	Remark
51.06	27.29	-12.71	40	50.1	8.02	0.71	31.54	121	54	Peak
144.21	24.32	-19.18	43.5	43.3	11.37	1.2	31.55	-	-	Peak
227.37	26.99	-19.01	46	45.96	11.02	1.46	31.45	-	-	Peak
383.3	24.62	-21.38	46	37.69	16.05	2.11	31.23	-	-	Peak
576.5	22.99	-23.01	46	31.92	19.4	2.62	30.95	-	-	Peak
709.5	21.62	-24.38	46	28.42	21.04	2.96	30.8	-	-	Peak
2390	51.97	-22.03	74	47.61	32.18	6.03	33.85	100	165	Peak
2390	36.47	-17.53	54	32.11	32.18	6.03	33.85	100	165	Average
2437	107.22	-	-	102.75	32.24	6.11	33.88	100	165	Peak
2437	94.23	-	-	89.76	32.24	6.11	33.88	100	165	Average
2484	50.65	-23.35	74	46.09	32.28	6.18	33.9	100	165	Peak
2484	36.01	-17.99	54	31.45	32.28	6.18	33.9	100	165	Average



Test Mode :	Mode 6	Temperature :	21~22°C
Test Channel :	11	Relative Humidity :	47~49%
Test Engineer :	David Yang	Polarization :	Horizontal
Remark :	2462 MHz is Fundamental Signals which can be ignored.		

Frequency (MHz)	Level (dBuV/m)	Over Limit (dB)	Limit Line (dBuV/m)	Read Level (dBuV)	Antenna Factor (dB)	Cable Loss (dB)	Preamp Factor (dB)	Ant Pos (cm)	Table Pos (deg)	Remark
50.25	27.22	-12.78	40	49.78	8.28	0.7	31.54	135	241	Peak
143.94	23.7	-19.8	43.5	42.63	11.42	1.2	31.55	-	-	Peak
224.94	24.4	-21.6	46	43.51	10.89	1.45	31.45	-	-	Peak
383.3	24.89	-21.11	46	37.96	16.05	2.11	31.23	-	-	Peak
480.6	21.56	-24.44	46	32.33	17.91	2.38	31.06	-	-	Peak
743.8	23.11	-22.89	46	29.19	21.58	3.05	30.71	-	-	Peak
2366	46.26	-27.74	74	41.98	32.13	5.99	33.84	118	28	Peak
2366	34.47	-19.53	54	30.19	32.13	5.99	33.84	118	28	Average
2462	94.85	-	-	90.34	32.26	6.14	33.89	118	28	Average
2462	107.8	-	-	103.29	32.26	6.14	33.89	118	28	Peak
2483.5	66.48	-7.52	74	61.92	32.28	6.18	33.9	118	28	Peak
2483.5	44.47	-9.53	54	39.91	32.28	6.18	33.9	118	28	Average



Test Mode :	Mode 6	Temperature :	21~22°C
Test Channel :	11	Relative Humidity :	47~49%
Test Engineer :	David Yang	Polarization :	Vertical
Remark :	2462 MHz is Fundamental Signals which can be ignored.		

Frequency (MHz)	Level (dBuV/m)	Over Limit (dB)	Limit Line (dBuV/m)	Read Level (dBuV)	Antenna Factor (dB)	Cable Loss (dB)	Preamp Factor (dB)	Ant Pos (cm)	Table Pos (deg)	Remark
50.25	27.55	-12.45	40	50.11	8.28	0.7	31.54	156	66	Peak
144.21	23.85	-19.65	43.5	42.83	11.37	1.2	31.55	-	-	Peak
240.33	27.99	-18.01	46	45.9	11.98	1.53	31.42	-	-	Peak
383.3	26.1	-19.9	46	39.17	16.05	2.11	31.23	-	-	Peak
576.5	23.73	-22.27	46	32.66	19.4	2.62	30.95	-	-	Peak
736.1	22.23	-23.77	46	28.47	21.46	3.03	30.73	-	-	Peak
2388	48.11	-25.89	74	43.75	32.18	6.03	33.85	124	4	Peak
2388	34.39	-19.61	54	30.03	32.18	6.03	33.85	124	4	Average
2462	93.63	-	-	89.12	32.26	6.14	33.89	124	4	Average
2462	106.38	-	-	101.87	32.26	6.14	33.89	124	4	Peak
2483.5	65.61	-8.39	74	61.05	32.28	6.18	33.9	124	4	Peak
2483.5	43.89	-10.11	54	39.33	32.28	6.18	33.9	124	4	Average



Test Mode :	Mode 7	Temperature :	21~22°C
Test Channel :	01	Relative Humidity :	47~49%
Test Engineer :	David Yang	Polarization :	Horizontal
Remark :	2412 MHz is Fundamental Signals which can be ignored.		

Frequency (MHz)	Level (dBuV/m)	Over Limit (dB)	Limit Line (dBuV/m)	Read Level (dBuV)	Antenna Factor (dB)	Cable Loss (dB)	Preamp Factor (dB)	Ant Pos (cm)	Table Pos (deg)	Remark
30.54	18.47	-21.53	40	33.12	16.27	0.54	31.46	-	-	Peak
144.21	29.88	-13.62	43.5	48.86	11.37	1.2	31.55	131	187	Peak
288.66	25.18	-20.82	46	41.52	13.29	1.69	31.32	-	-	Peak
335.7	32.05	-13.95	46	46.91	14.57	1.87	31.3	-	-	Peak
383.3	28.79	-17.21	46	41.86	16.05	2.11	31.23	-	-	Peak
576.5	24.82	-21.18	46	33.75	19.4	2.62	30.95	-	-	Peak
2389.99	70.09	-3.91	74	65.73	32.18	6.03	33.85	147	313	Peak
2389.99	50.02	-3.98	54	45.66	32.18	6.03	33.85	147	313	Average
2412	107.59	-	-	103.19	32.2	6.07	33.87	147	313	Peak
2412	94.33	-	-	89.93	32.2	6.07	33.87	147	313	Average
2484	34.92	-19.08	54	30.36	32.28	6.18	33.9	147	313	Average
2484	47.27	-26.73	74	42.71	32.28	6.18	33.9	147	313	Peak



Test Mode :	Mode 7	Temperature :	21~22°C
Test Channel :	01	Relative Humidity :	47~49%
Test Engineer :	David Yang	Polarization :	Vertical
Remark :	2412 MHz is Fundamental Signals which can be ignored.		

Frequency (MHz)	Level (dBuV/m)	Over Limit (dB)	Limit Line (dBuV/m)	Read Level (dBuV)	Antenna Factor (dB)	Cable Loss (dB)	Preamp Factor (dB)	Ant Pos (cm)	Table Pos (deg)	Remark
49.98	26.96	-13.04	40	49.52	8.28	0.7	31.54	100	311	Peak
144.21	24.53	-18.97	43.5	43.51	11.37	1.2	31.55	-	-	Peak
244.38	23.79	-22.21	46	41.42	12.26	1.53	31.42	-	-	Peak
383.3	25.66	-20.34	46	38.73	16.05	2.11	31.23	-	-	Peak
405	24.18	-21.82	46	36.53	16.66	2.16	31.17	-	-	Peak
576.5	22.98	-23.02	46	31.91	19.4	2.62	30.95	-	-	Peak
2388.85	67.07	-6.93	74	62.71	32.18	6.03	33.85	102	165	Peak
2388.85	46.39	-7.61	54	42.03	32.18	6.03	33.85	102	165	Average
2412	104.57	-	-	100.17	32.2	6.07	33.87	102	165	Peak
2412	91.61	-	-	87.21	32.2	6.07	33.87	102	165	Average
2484	34.58	-19.42	54	30.02	32.28	6.18	33.9	102	165	Average
2484	46.77	-27.23	74	42.21	32.28	6.18	33.9	102	165	Peak



Test Mode :	Mode 8	Temperature :	21~22°C
Test Channel :	06	Relative Humidity :	47~49%
Test Engineer :	David Yang	Polarization :	Horizontal
Remark :	2437 MHz is Fundamental Signals which can be ignored.		

Frequency (MHz)	Level (dBuV/m)	Over Limit (dB)	Limit Line (dBuV/m)	Read Level (dBuV)	Antenna Factor (dB)	Cable Loss (dB)	Preamp Factor (dB)	Ant Pos (cm)	Table Pos (deg)	Remark
48.9	21.59	-18.41	40	43.36	9.08	0.68	31.53	-	-	Peak
144.21	30.31	-13.19	43.5	49.29	11.37	1.2	31.55	126	47	Peak
240.33	24.11	-21.89	46	42.02	11.98	1.53	31.42	-	-	Peak
335.7	30.97	-15.03	46	45.83	14.57	1.87	31.3	-	-	Peak
416.2	27.95	-18.05	46	40.08	16.83	2.2	31.16	-	-	Peak
480.6	26.06	-19.94	46	36.83	17.91	2.38	31.06	-	-	Peak
2390	49.53	-24.47	74	45.17	32.18	6.03	33.85	151	312	Peak
2390	36.96	-17.04	54	32.6	32.18	6.03	33.85	151	312	Average
2437	106.77	-	-	102.32	32.22	6.11	33.88	151	312	Peak
2437	94.11	-	-	89.64	32.24	6.11	33.88	151	312	Average
2484	50.17	-23.83	74	45.61	32.28	6.18	33.9	151	312	Peak
2484	34.53	-19.47	54	29.97	32.28	6.18	33.9	151	312	Average



Test Mode :	Mode 8	Temperature :	21~22°C
Test Channel :	06	Relative Humidity :	47~49%
Test Engineer :	David Yang	Polarization :	Vertical
Remark :	2437 MHz is Fundamental Signals which can be ignored.		

Frequency (MHz)	Level (dBuV/m)	Over Limit (dB)	Limit Line (dBuV/m)	Read Level (dBuV)	Antenna Factor (dB)	Cable Loss (dB)	Preamp Factor (dB)	Ant Pos (cm)	Table Pos (deg)	Remark
49.17	26.8	-13.2	40	48.96	8.68	0.69	31.53	141	155	Peak
197.94	25.5	-18	43.5	46.59	9.09	1.31	31.49	-	-	Peak
241.41	25.8	-20.2	46	43.64	12.05	1.53	31.42	-	-	Peak
383.3	25.47	-20.53	46	38.54	16.05	2.11	31.23	-	-	Peak
394.5	24.11	-21.89	46	36.76	16.41	2.13	31.19	-	-	Peak
576.5	23.39	-22.61	46	32.32	19.4	2.62	30.95	-	-	Peak
2390	48.57	-25.43	74	44.21	32.18	6.03	33.85	100	165	Peak
2390	35.08	-18.92	54	30.72	32.18	6.03	33.85	100	165	Average
2437	104.86	-	-	100.41	32.22	6.11	33.88	100	165	Peak
2437	92.42	-	-	87.95	32.24	6.11	33.88	100	165	Average
2484	50.04	-23.96	74	45.48	32.28	6.18	33.9	100	165	Peak
2484	35.5	-18.5	54	30.94	32.28	6.18	33.9	100	165	Average



Test Mode :	Mode 9	Temperature :	21~22°C
Test Channel :	11	Relative Humidity :	47~49%
Test Engineer :	David Yang	Polarization :	Horizontal
Remark :	2462 MHz is Fundamental Signals which can be ignored.		

Frequency (MHz)	Level (dBuV/m)	Over Limit (dB)	Limit Line (dBuV/m)	Read Level (dBuV)	Antenna Factor (dB)	Cable Loss (dB)	Preamp Factor (dB)	Ant Pos (cm)	Table Pos (deg)	Remark
48.9	22.08	-17.92	40	43.85	9.08	0.68	31.53	-	-	Peak
143.94	30.08	-13.42	43.5	49.01	11.42	1.2	31.55	122	147	Peak
240.33	24.44	-21.56	46	42.35	11.98	1.53	31.42	-	-	Peak
335.7	30.82	-15.18	46	45.68	14.57	1.87	31.3	-	-	Peak
383.3	28.57	-17.43	46	41.64	16.05	2.11	31.23	-	-	Peak
480.6	26.38	-19.62	46	37.15	17.91	2.38	31.06	-	-	Peak
2382	48.33	-25.67	74	43.99	32.16	6.03	33.85	120	27	Peak
2382	35.06	-18.94	54	30.72	32.16	6.03	33.85	120	27	Average
2462	93.96	-	-	89.45	32.26	6.14	33.89	120	27	Average
2462	107.23	-	-	102.72	32.26	6.14	33.89	120	27	Peak
2483.5	64.11	-9.89	74	59.55	32.28	6.18	33.9	120	27	Peak
2483.5	44.38	-9.62	54	39.82	32.28	6.18	33.9	120	27	Average



Test Mode :	Mode 9	Temperature :	21~22°C
Test Channel :	11	Relative Humidity :	47~49%
Test Engineer :	David Yang	Polarization :	Vertical
Remark :	2462 MHz is Fundamental Signals which can be ignored.		

Frequency (MHz)	Level (dBuV/m)	Over Limit (dB)	Limit Line (dBuV/m)	Read Level (dBuV)	Antenna Factor (dB)	Cable Loss (dB)	Preamp Factor (dB)	Ant Pos (cm)	Table Pos (deg)	Remark
49.17	26.98	-13.02	40	49.14	8.68	0.69	31.53	109	100	Peak
143.94	24.28	-19.22	43.5	43.21	11.42	1.2	31.55	-	-	Peak
240.33	27.32	-18.68	46	45.23	11.98	1.53	31.42	-	-	Peak
383.3	25.17	-20.83	46	38.24	16.05	2.11	31.23	-	-	Peak
405	23.18	-22.82	46	35.53	16.66	2.16	31.17	-	-	Peak
576.5	23.51	-22.49	46	32.44	19.4	2.62	30.95	-	-	Peak
2390	46.42	-27.58	74	42.06	32.18	6.03	33.85	103	189	Peak
2390	34.79	-19.21	54	30.43	32.18	6.03	33.85	103	189	Average
2462	89.57	-	-	85.06	32.26	6.14	33.89	103	189	Average
2462	102.14	-	-	97.63	32.26	6.14	33.89	103	189	Peak
2483.85	58.99	-15.01	74	54.43	32.28	6.18	33.9	103	189	Peak
2483.85	40.85	-13.15	54	36.29	32.28	6.18	33.9	103	189	Average



3.8 Antenna Requirements

3.8.1 Standard Applicable

If directional gain of transmitting antennas is greater than 6dBi, the power shall be reduced by the same level in dB comparing to gain minus 6dBi. For the fixed point-to-point operation, the power shall be reduced by one dB for every 3 dB that the directional gain of the antenna exceeds 6 dBi. The use of a permanently attached antenna or of an antenna that uses a unique coupling to the intentional radiator shall be considered sufficient to comply with the FCC rule.

3.8.2 Antenna Connected Construction

The antennas type used in this product is PIFA Antenna without connector and it is considered to meet antenna requirement.

3.8.3 Antenna Gain

The antenna peak gain of EUT is less than 6 dBi. Therefore, it is not necessary to reduce maximum peak output power limit.

4 List of Measuring Equipment

Instrument	Manufacturer	Model No.	Serial No.	Characteristics	Calibration Date	Due Date	Remark
System Simulator	R&S	CMU200	117995	N/A	Mar. 19, 2009	Mar. 18, 2011	Conducted (TH02-HY)
Spectrum Analyzer	R&S	FSP40	100055	9kHz~40GHz	Jun. 11, 2010	Jun. 10, 2011	Conducted (TH02-HY)
Power Meter	Anritsu	ML2495A	0932001	N/A	Sep. 13, 2010	Sep. 12, 2011	Conducted (TH02-HY)
Power Sensor	Anritsu	MA2411B	0846202	N/A	Sep. 14, 2010	Sep. 13, 2011	Conducted (TH02-HY)
Thermal Chamber	Ten Billion	TTH-D35P	TBN-930701	N/A	Jul. 30,2010	Jul. 29, 2011	Conducted (TH02-HY)
EMI Test Receive	R&S	ESCS 30	100356	9KHz – 2.75GHz	Aug. 16, 2010	Aug. 15, 2011	Conduction (CO05-HY)
Two-LISN	R&S	ENV216	11-100081	9KHz – 30MHz	Dec. 03, 2010	Dec. 02, 2011	Conduction (CO05-HY)
Two-LISN	R&S	ENV216	11-100080	9KHz – 30MHz	Dec. 01, 2010	Nov. 30, 2011	Conduction (CO05-HY)
AC Power Source	APC	APC-1000W	N/A	N/A	N/A	N/A	Conduction (CO05-HY)
System Simulator	R&S	CMU200	117995	N/A	Mar. 19, 2009	Mar. 18, 2011	Conduction (CO05-HY)
GPS Station	T&E	GS-50	N/A	N/A	N/A	N/A	Conduction (CO05-HY)
Bilog Antenna	SCHAFFNER	CBL6111C	2726	30MHz ~ 1GHz	Oct. 31, 2010	Oct. 30, 2011	Radiation (03CH07-HY)
Spectrum Analyzer	R&S	FSP	101067	9KHz ~ 30GHz	Dec. 03, 2010	Dec. 02, 2011	Radiation (03CH07-HY)
Double Ridge Horn Antenna	ESCO	3117	00075962	1GHz ~ 18GHz	Aug. 19, 2010	Aug. 18, 2011	Radiation (03CH07-HY)
SHF-EHF Horn Antenna	SCHWARZBECK	BBHA 9170	BBHA9170251	15GHz- 40GHz	Oct. 18, 2010	Oct. 17, 2011	Radiation (03CH07-HY)
Pre Amplifier	Agilent	8449B	3008A02362	1GHz~ 26.5GHz	Dec. 06, 2010	Dec. 05, 2011	Radiation (03CH07-HY)
Pre Amplifier	COM-POWER	PA-103A	161241	10-1000MHz.32 dB.GAIN	Mar. 27, 2010	Mar. 26, 2011	Radiation (03CH07-HY)
Loop Antenna	R&S	HFH2-Z2	860004/001	9 kHz~30 MHz	Jul. 29, 2010	Jul. 28, 2011	Radiation (03CH07-HY)
Bluetooth Base Station	R&S	CBT32	100519	N/A	May 12, 2009	May 11, 2011	Radiation (03CH07-HY)

5 Uncertainty of Evaluation

Uncertainty of Conducted Emission Measurement (150 kHz ~ 30 MHz)

Contribution	Uncertainty of X_i		$u(X_i)$
	dB	Probability Distribution	
Receiver Reading	0.10	Normal (k=2)	0.05
Cable Loss	0.10	Normal (k=2)	0.05
AMN Insertion Loss	2.50	Rectangular	0.63
Receiver Specification	1.50	Rectangular	0.43
Site Imperfection	1.39	Rectangular	0.80
Mismatch	+0.34 / -0.35	U-Shape	0.24
Combined Standard Uncertainty $U_c(y)$	1.13		
Measuring Uncertainty for a Level of Confidence of 95% ($U = 2U_c(y)$)	2.26		

Uncertainty of Radiated Emission Measurement (30 MHz ~ 1000 MHz)

Contribution	Uncertainty of X_i		$u(X_i)$
	dB	Probability Distribution	
Receiver Reading	0.41	Normal (k=2)	0.21
Antenna Factor Calibration	0.83	Normal (k=2)	0.42
Cable Loss Calibration	0.25	Normal (k=2)	0.13
Pre-Amplifier Gain Calibration	0.27	Normal (k=2)	0.14
RCV/SPA Specification	2.50	Rectangular	0.72
Antenna Factor Interpolation for Frequency	1.00	Rectangular	0.29
Site Imperfection	1.43	Rectangular	0.83
Mismatch	+0.39 / -0.41	U-Shape	0.28
Combined Standard Uncertainty $U_c(y)$	1.27		
Measuring Uncertainty for a Level of Confidence of 95% ($U = 2U_c(y)$)	2.54		



Uncertainty of Radiated Emission Measurement (1 GHz ~ 40 GHz)

Contribution	Uncertainty of X_i		$u(X_i)$	C_i	$C_i * u(X_i)$
	dB	Probability Distribution			
Receiver Reading	±0.10	Normal (k=2)	0.10	1	0.10
Antenna Factor Calibration	±1.70	Normal (k=2)	0.85	1	0.85
Cable Loss Calibration	±0.50	Normal (k=2)	0.25	1	0.25
Receiver Correction	±2.00	Rectangular	1.15	1	1.15
Antenna Factor Directional	±1.50	Rectangular	0.87	1	0.87
Site Imperfection	±2.80	Triangular	1.14	1	1.14
Mismatch Receiver VSWR $\Gamma_1 = 0.197$ Antenna VSWR $\Gamma_2 = 0.194$ Uncertainty = $20\text{Log}(1-\Gamma_1*\Gamma_2)$	+0.34 / -0.35	U-Shape	0.244	1	0.244
Combined Standard Uncertainty Uc(y)	2.36				
Measuring Uncertainty for a Level of Confidence of 95% (U = 2Uc(y))	4.72				