



FCC RF Test Report

APPLICANT : HTC Coporation
EQUIPMENT : Tablent computer
MODEL NAME : PG09410
FCC ID : NM8PG09410
STANDARD : 47 CFR Part 2, 27
CLASSIFICATION : PCS Licensed Transmitter (PCB)
TX FREQUENCY RANGE : 1710 MHz ~ 1755 MHz (LTE – Band 4)
: 704 MHz ~ 716 MHz (LTE – Band 17)
RX FREQUENCY RANGE : 2110 MHz ~ 2155 MHz (LTE – Band 4)
: 734 MHz ~ 746 MHz (LTE – Band 17)
MAX. ERP POWER : 0.29 W (LTE Band 4 QPSK, BW 5MHz)
: 0.23 W (LTE Band 4 16 QAM, BW 5MHz)
: 0.28 W (LTE Band 4 QPSK, BW 10MHz)
: 0.24 W (LTE Band 4 16 QAM, BW 10MHz)
: 0.11 W (LTE Band 17 QPSK, BW 5MHz)
: 0.08 W (LTE Band 17 16 QAM, BW 5MHz)
: 0.07 W (LTE Band 17 QPSK, BW 10MHz)
: 0.06 W (LTE Band 17 16 QAM, BW 10MHz)
Emission Designator : 4M50G7D (QPSK, BW 5MHz)
: 4M52D7W (16QAM, BW 5MHz)
: 9M12G7D (QPSK, BW 10MHz)
: 9M08D7W (16QAM, BW 10MHz)



The product was received on May 29, 2011 and completely tested on Jun. 23, 2011. We, SPORTON INTERNATIONAL INC., would like to declare that the tested sample has been evaluated in accordance with the procedures given in ANSI / TIA / EIA-603-C-2004 and shown compliance with the applicable technical standards.

The test results in this report apply exclusively to the tested model / sample. Without written approval of SPORTON INTERNATIONAL INC., the test report shall not be reproduced except in full.

Reviewed by:

Jones Tsai / Manager



SPORTON INTERNATIONAL INC.

No. 52, Hwa Ya 1st Rd., Hwa Ya Technology Park, Kwei-Shan Hsiang, Tao Yuan Hsien, Taiwan, R.O.C.



TABLE OF CONTENTS

REVISION HISTORY..... 4

SUMMARY OF TEST RESULT 5

1 GENERAL DESCRIPTION 6

 1.1 Applicant 6

 1.2 Manufacturer 6

 1.3 Feature of Equipment Under Test 6

 1.4 Testing Site 7

 1.5 Applied Standards 7

 1.6 Ancillary Equipment List 7

2 TEST CONFIGURATION OF EQUIPMENT UNDER TEST 8

 2.1 Test Mode 8

 2.2 Connection Diagram of Test System 9

3 TEST RESULT 10

 3.1 Conducted Output Power Measurement 10

 3.2 Effective Radiated Power and Effective Isotropic Radiated Power Measurement 12

 3.3 Occupied Bandwidth 16

 3.4 Emission Mask Measurement 21

 3.5 Conducted Emission Measurement 30

 3.6 Field Strength of Spurious Radiation Measurement 55

 3.7 Frequency Stability Measurement 73

4 LIST OF MEASURING EQUIPMENTS 76

5 UNCERTAINTY OF EVALUATION 77

APPENDIX A. SETUP PHOTOGRAPHS



REVISION HISTORY

REPORT NO.	VERSION	DESCRIPTION	ISSUED DATE
FG132945B	Rev. 01	Initial issue of report	Jun. 24, 2011



SUMMARY OF TEST RESULT

Report Section	FCC Rule	Description	Limit	Result	Remark
3.1	§2.1046	Conducted Output Power	NA	PASS	
3.2	§27.50(c)(10) §27.50(d)(4)	Effective Radiated Power and Effective Isotropic Radiated Power Measurement	< 3 Watts (ERP) < 1 Watt (EIRP)	PASS	-
3.3	§2.1049	Occupied Bandwidth	NA	PASS	-
3.4	§2.1049 §27.53(h)(g)	Emission Mask Measurement	< $43+10\log_{10}(P[\text{Watts}])$	PASS	-
3.5	§2.1051 §27.53(h)(g)	Conducted Emission	< $43+10\log_{10}(P[\text{Watts}])$	PASS	-
3.6	§2.1053 §27.53(h)(g)	Undesirable Out of Band Emissions	< $43+10\log_{10}(P[\text{Watts}])$	PASS	Under limit 22.69 dB at 1420 MHz -
3.7	§2.1055 §27.54	Frequency Stability Temperature & Voltage	< 2.5 ppm	PASS	



1 General Description

1.1 Applicant

HTC Coporation

No. 6-3, Baoquang Rd., Xindian City, Taipei County, Taiwan

1.2 Manufacturer

HTC Coporation

No. 6-3, Baoquang Rd., Xindian City, Taipei County, Taiwan

1.3 Feature of Equipment Under Test

Product Feature & Specification	
Equipment	Tablet computer
Model Name	PG09410
FCC ID	NM8PG09410
Tx Frequency	LTE Band 4 : 1710 MHz ~ 1755 MHz LTE Band 17 : 704 MHz ~ 716 MHz
Rx Frequency	LTE Band 4 : 2110 MHz ~ 2155 MHz LTE Band 17 : 734 MHz ~ 746 MHz
Maximum Output Power to Antenna	LTE Band 4 : 23.25 dBm LTE Band 17 : 23.08 dBm
Maximum ERP/EIRP	0.29 W (24.57 dBm) (LTE Band 4 QPSK, BW 5MHz) 0.23 W (23.67 dBm) (LTE Band 4 16QAM, BW 5MHz) 0.28 W (24.49 dBm) (LTE Band 4 QPSK, BW 10MHz) 0.24 W (23.71 dBm) (LTE Band 4 16QAM, BW 10MHz) 0.11 W (18.15 dBm) (LTE Band 17 QPSK, BW 5MHz) 0.08 W (16.96 dBm) (LTE Band 17 16QAM, BW 5MHz) 0.07 W (18.55 dBm) (LTE Band 17 QPSK, BW 10MHz) 0.06 W (17.96 dBm) (LTE Band 17 16QAM, BW 10MHz)
Antenna Type	Fixed Internal Antenna
Type of Modulation	4M50G7D (QPSK, BW 5MHz) 4M52D7W (16QAM, BW 5MHz) 9M12G7D (QPSK, BW 10MHz) 9M08D7W (16QAM, BW 10MHz)
EUT Stage	Production Unit

Remark:

1. For other wireless features of this EUT, the test report will be issued separately.
2. This test report recorded only product characteristics and test results of PCS Licensed Transmitter (PCB).

1.4 Testing Site

Test Site	SPORTON INTERNATIONAL INC.		
Test Site Location	No. 52, Hwa Ya 1 st Rd., Hwa Ya Technology Park, Kwei-Shan Hsiang, Tao Yuan Hsien, Taiwan, R.O.C. TEL: +886-3-327-3456 FAX: +886-3-328-4978		
Test Site No.	Sporton Site No.		FCC/IC Registration No.
	TH02-HY	03CH07-HY	TW1022/4086B-1

1.5 Applied Standards

According to the specifications of the manufacturer, the EUT must comply with the requirements of the following standards:

- ♦ 47 CFR Part 2, 27
- ♦ ANSI / TIA / EIA-603-C-2004

Remark:

1. All test items were verified and recorded according to the standards and without any deviation during the test.
2. This EUT has also been tested and complied with the requirements of FCC Part 15, Subpart B (DoC), recorded in a separate test report.

1.6 Ancillary Equipment List

Item	Equipment	Trade Name	Model No.	FCC ID	Data Cable	Power Cord
1.	System Simulator	Anritsu	MT8820C	N/A	N/A	Unshielded, 1.8 m

2 Test Configuration of Equipment Under Test

2.1 Test Mode

During all testing, EUT is in link mode with base station emulator at maximum power level. The spurious emission measurements were carried out in semi-anechoic chamber with 3-meter test range.

Frequency range investigated for radiated emission: 30MHz to 10th harmonic.

Test Modes			
Band		Radiated TCs	Conducted TCs
LTE Band 4	BW 5MHz	<ul style="list-style-type: none"> ■ LTE (RB Size 1, RB Offset 0) Link + TC ■ LTE (RB Size 1, RB Offset 24) Link + TC 	<ul style="list-style-type: none"> ■ LTE (RB Size 1, RB Offset 0) Link ■ LTE (RB Size 1, RB Offset 24) Link ■ LTE (RB Size 12, RB Offset 6) Link ■ LTE (RB Size 25, RB Offset 0) Link
	BW 10MHz	<ul style="list-style-type: none"> ■ LTE (RB Size 1, RB Offset 0) Link + TC ■ LTE (RB Size 1, RB Offset 49) Link + TC 	<ul style="list-style-type: none"> ■ LTE (RB Size 1, RB Offset 0)Link ■ LTE (RB Size 1, RB Offset 49)Link ■ LTE (RB Size 25, RB Offset 13)Link ■ LTE (RB Size 50, RB Offset 0)Link
LTE Band 17	BW 5MHz	<ul style="list-style-type: none"> ■ LTE (RB Size 1, RB Offset 0) Link + TC ■ LTE (RB Size 1, RB Offset 24) Link + TC 	<ul style="list-style-type: none"> ■ LTE (RB Size 1, RB Offset 0) Link ■ LTE (RB Size 1, RB Offset 24) Link ■ LTE (RB Size 12, RB Offset 6) Link ■ LTE (RB Size 25, RB Offset 0) Link
	BW 10MHz	<ul style="list-style-type: none"> ■ LTE (RB Size 1, RB Offset 0) Link + TC ■ LTE (RB Size 1, RB Offset 49) Link + TC 	<ul style="list-style-type: none"> ■ LTE (RB Size 1, RB Offset 0)Link ■ LTE (RB Size 1, RB Offset 49)Link ■ LTE (RB Size 25, RB Offset 13)Link ■ LTE (RB Size 50, RB Offset 0)Link
<p>Remark: TC stands for Test Configuration, and consists of Adapter, Battery and USB Cable.</p>			

2.2 Connection Diagram of Test System

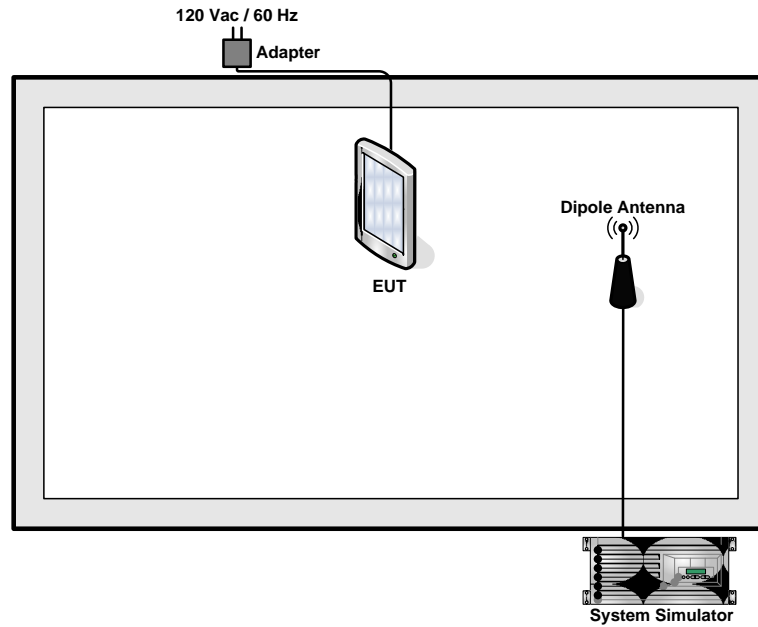

3 Test Result

3.1 Conducted Output Power Measurement

3.1.1 Description of the Conducted Output Power Measurement

A base station simulator was used to establish communication with the EUT. Its parameters were set to transmit the maximum power on the EUT. The measured power in the radio frequency on the transmitter output terminals shall be reported.

3.1.2 Measuring Instruments

See list of measuring instruments of this test report.

3.1.3 Test Procedures

1. The transmitter output port was connected to base station.
2. Set EUT at maximum power through base station.
3. Select lowest, middle, and highest channels for each band and different modulation.

3.1.4 Test Setup

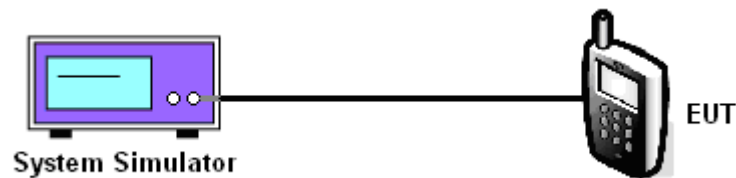



3.1.5 Test Result of Conducted Output Power

Mode	Band Width	Channel	Frequency (MHz)	Conducted Power (dBm)	Conducted Power (Watts)	PAPR (dB)
LTE Band 4	5MHz	19975	1712.5	23.25	0.2113	5.56
		20175	1732.5	23.24	0.2109	5.56
		20375	1752.5	23.25	0.2113	5.28
	10MHz	20000	1715	23.19	0.2084	5.64
		20175	1732.5	23.20	0.2089	5.6
		20350	1750	23.25	0.2113	5.44
LTE Band 17	5MHz	23755	706.5	23.06	0.2023	5.84
		23790	710	23.08	0.2032	5.76
		23825	713.5	22.90	0.1950	6.08
	10MHz	23780	709	23.05	0.2018	5.44
		23790	710	23.02	0.2004	5.44
		23800	711	22.61	0.1824	5.56



3.2 Effective Radiated Power and Effective Isotropic Radiated Power Measurement

3.2.1 Description of the ERP/EIRP Measurement

ERP/EIRP is measured by substitution method according to ANSI / TIA / EIA-603-C-2004. The ERP of mobile transmitters must not exceed 3 Watts and the EIRP of mobile transmitters are limited to 1 Watts.

3.2.2 Measuring Instruments

See list of measuring instruments of this test report.

3.2.3 Test Procedures

1. The EUT was placed on a non-conductive rotating platform with 0.8 meter height in a semi-anechoic chamber. The radiated emission at the fundamental frequency was measured at 3 m with a test antenna and a spectrum analyzer with RBW= 300kHz, VBW= 1MHz, RMS detector, and used Channel Power function with measurement bandwidth = 5MHz/10MHz.
2. During the measurement, the EUT was enforced in maximum power and linked with a base station. The highest emission was recorded from analyzer power level (LVL) from the 360 degrees rotation of the turntable and the test antenna raised and lowered over a range from 1 to 4 meters in both horizontally and vertically polarized orientations.
3. Effective Radiated Power (ERP)/ Effective Isotropic Radiated Power (EIRP) was measured by substitution method according to TIA/EIA-603-C. The EUT was replaced by dipole antenna (substitution antenna) at same location, and then a known power from S.G. was applied into the dipole antenna through a Tx cable, and then recorded the maximum Analyzer reading through raised and lowered the test antenna. The correction factor (in dB) = S.G. - Tx Cable loss + Substitution antenna gain - Analyzer reading. Then the EUT's ERP/EIRP was calculated with the correction factor, $ERP/EIRP = LVL + \text{Correction factor}$.

3.2.4 Test Setup

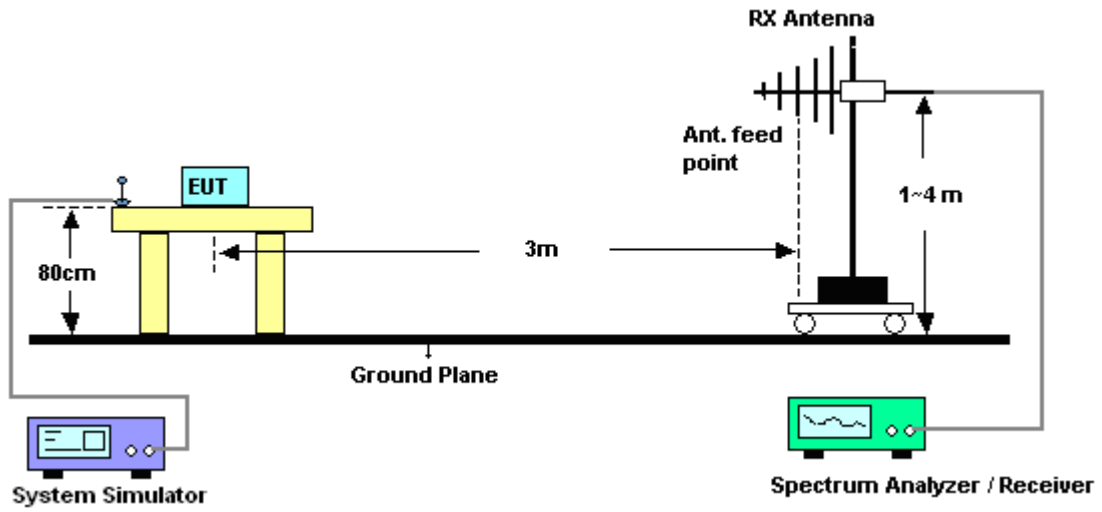

3.2.5 Test Result of ERP

LTE Band 17 Radiated Power ERP for BW 5MHz					
Ch.	Mod.	LVL (dBm)	Correction Factor (dB)	ERP (dBm)	ERP (W)
23755	QPSK	-10.40	27.7	17.30	0.05
	16QAM	-10.97	27.7	16.73	0.05
23790	QPSK	-9.55	27.7	18.15	0.11
	16QAM	-10.75	27.7	16.95	0.08
23825	QPSK	-9.93	27.7	17.77	0.10
	16QAM	-10.74	27.7	16.96	0.08

* ERP = LVL (dBm) + Correction Factor (dB)

LTE Band 17 Radiated Power ERP for BW 10MHz					
Ch.	Mod.	LVL (dBm)	Correction Factor (dB)	ERP (dBm)	ERP (W)
23780	QPSK	-9.15	27.7	18.55	0.07
	16QAM	-9.74	27.7	17.96	0.06
23790	QPSK	-10.57	27.7	17.13	0.05
	16QAM	-11.32	27.7	16.38	0.04
23800	QPSK	-9.36	27.7	18.34	0.07
	16QAM	-10.16	27.7	17.54	0.06

* ERP = LVL (dBm) + Correction Factor (dB)

3.2.6 Test Result of EIRP

LTE Band 4 Radiated Power EIRP for BW 5MHz					
Ch.	Mod.	LVL (dBm)	Correction Factor (dB)	EIRP (dBm)	EIRP (W)
19975	QPSK	-15.59	39.24	23.65	0.23
	16QAM	-16.41	39.24	22.83	0.19
20175	QPSK	-15.68	40.25	24.57	0.29
	16QAM	-16.58	40.25	23.67	0.23
20375	QPSK	-16.22	40.31	24.09	0.26
	16QAM	-17.01	40.31	23.30	0.21

* EIRP = LVL (dBm) + Correction Factor (dB)

LTE Band 4 Radiated Power EIRP for BW 10MHz					
Ch.	Mod.	LVL (dBm)	Correction Factor (dB)	EIRP (dBm)	EIRP (W)
20000	QPSK	-15.53	39.24	23.71	0.23
	16QAM	-16.47	39.24	22.77	0.19
20175	QPSK	-15.76	40.25	24.49	0.28
	16QAM	-16.54	40.25	23.71	0.24
20350	QPSK	-16.24	40.31	24.07	0.26
	16QAM	-16.91	40.31	23.40	0.22

* EIRP = LVL (dBm) + Correction Factor (dB)

3.3 Occupied Bandwidth

3.3.1 Description of Occupied Bandwidth Measurement

The occupied bandwidth is the width of a frequency band such that, below the lower and above the upper frequency limits, the mean powers emitted are each equal to a specified percentage 0.5% of the total mean transmitted power.

3.3.2 Measuring Instruments

See list of measuring instruments of this test report.

3.3.3 Test Procedures

4. The EUT was connected to Spectrum Analyzer and Base Station via power divider.
5. The 99% occupied bandwidth (BW) of the middle channel for the highest RF powers were measured.

3.3.4 Test Setup

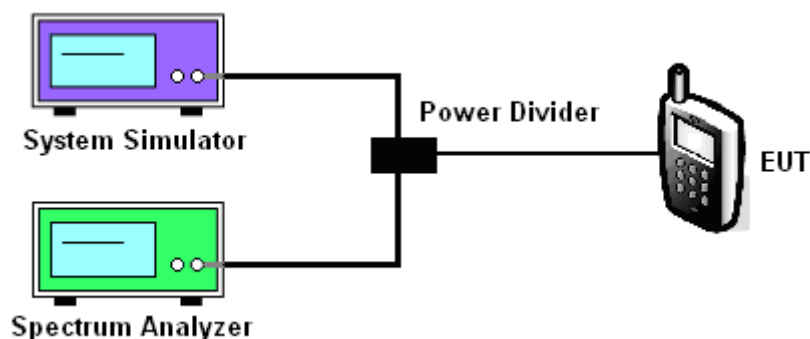



3.3.5 Test Result (Plots) of Occupied Bandwidth

Band :	LTE Band 4	BW / Mod. :	5MHz / QPSK
--------	------------	-------------	-------------

99% Occupied Bandwidth Plot on Channel 20175

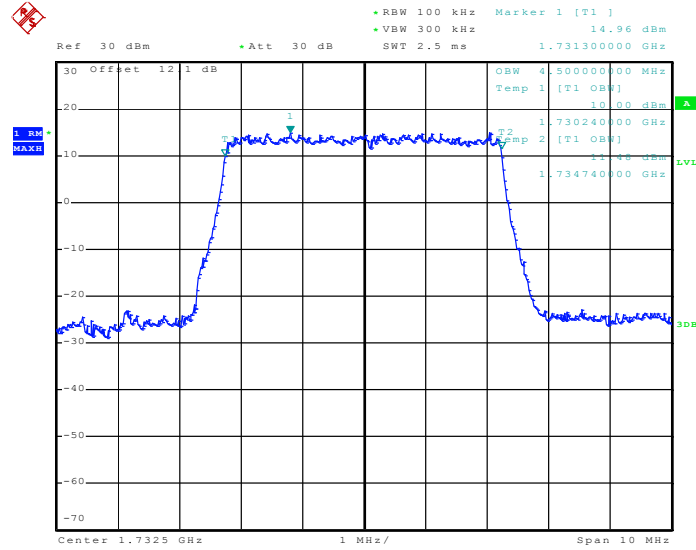

Date: 8.JUN.2011 17:54:39

Band :	LTE Band 4	BW / Mod. :	5MHz / 16QAM
--------	------------	-------------	--------------

99% Occupied Bandwidth Plot on Channel 20175

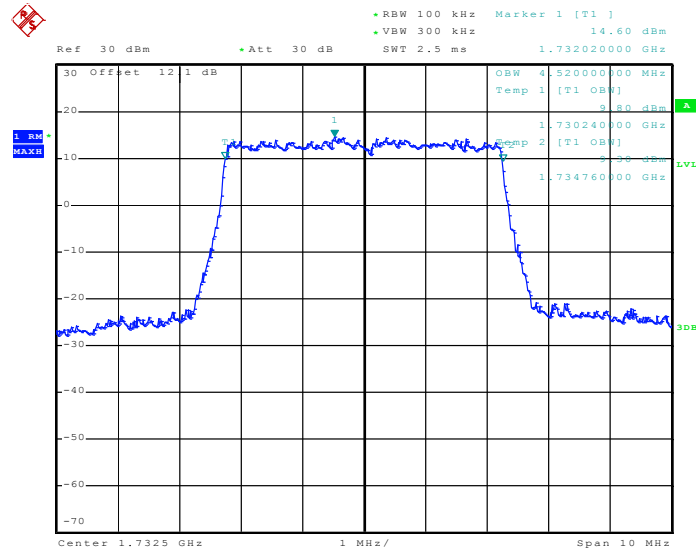

Date: 8.JUN.2011 17:53:18



Band :	LTE Band 4	BW / Mod. :	10MHz / QPSK
---------------	------------	--------------------	--------------

99% Occupied Bandwidth Plot on Channel 20175

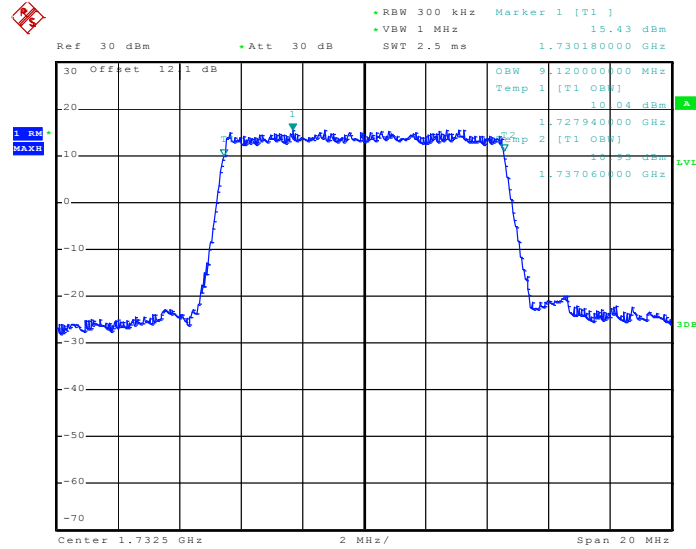

Date: 8.JUN.2011 17:40:31

Band :	LTE Band 4	BW / Mod. :	10MHz / 16QAM
---------------	------------	--------------------	---------------

99% Occupied Bandwidth Plot on Channel 20175

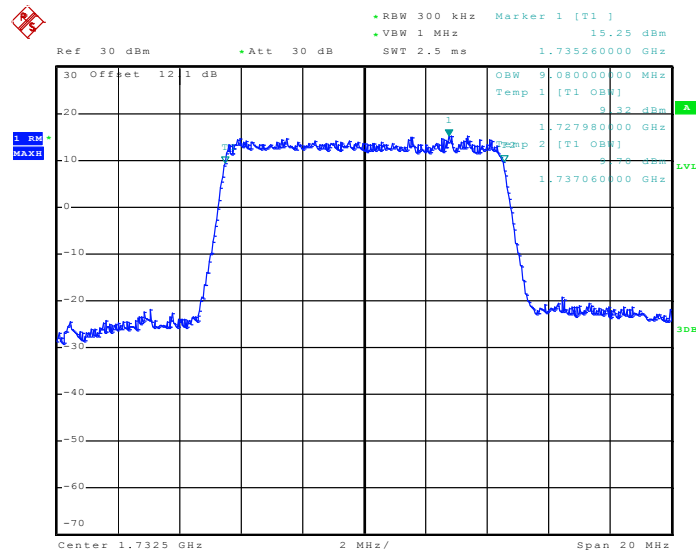

Date: 8.JUN.2011 18:10:13



Band :	LTE Band 17	BW / Mod. :	5MHz / QPSK
---------------	-------------	--------------------	-------------

99% Occupied Bandwidth Plot on Channel 23790

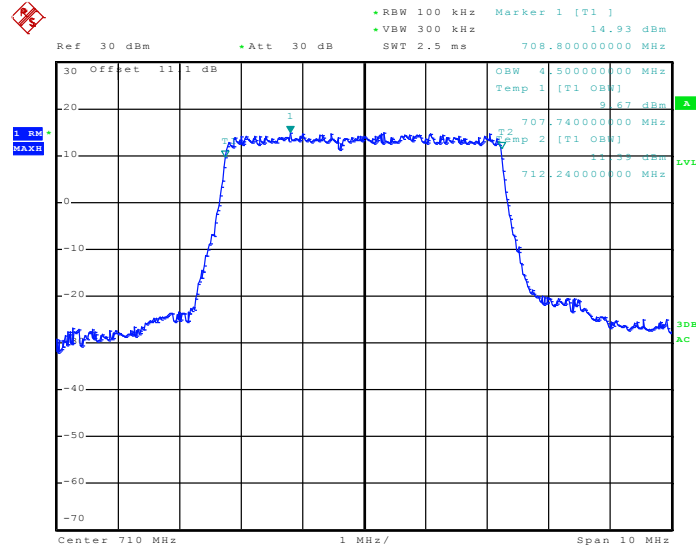

Date: 9.JUN.2011 23:19:42

Band :	LTE Band 17	BW / Mod. :	5MHz / 16QAM
---------------	-------------	--------------------	--------------

99% Occupied Bandwidth Plot on Channel 23790

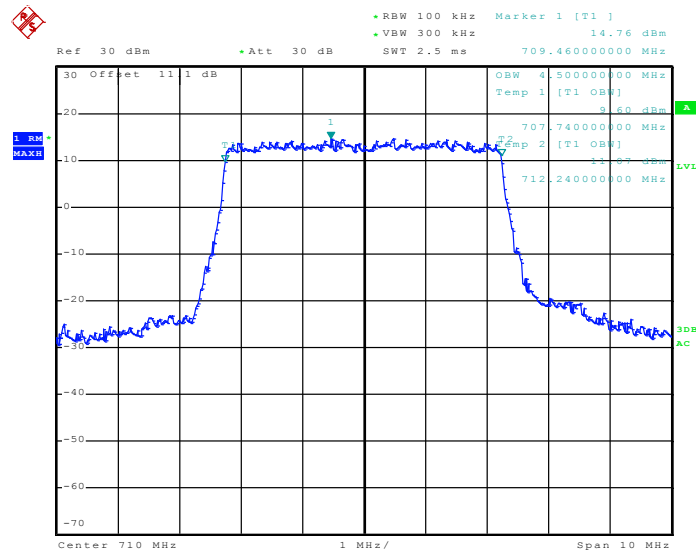

Date: 9.JUN.2011 23:18:36



Band :	LTE Band 17	BW / Mod. :	10MHz / QPSK
--------	-------------	-------------	--------------

99% Occupied Bandwidth Plot on Channel 23790

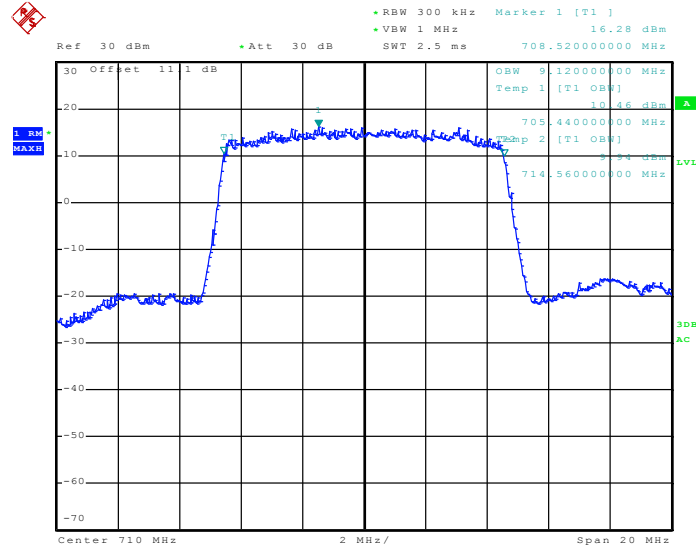

Date: 9.JUN.2011 23:03:56

Band :	LTE Band 17	BW / Mod. :	10MHz / 16QAM
--------	-------------	-------------	---------------

99% Occupied Bandwidth Plot on Channel 23790

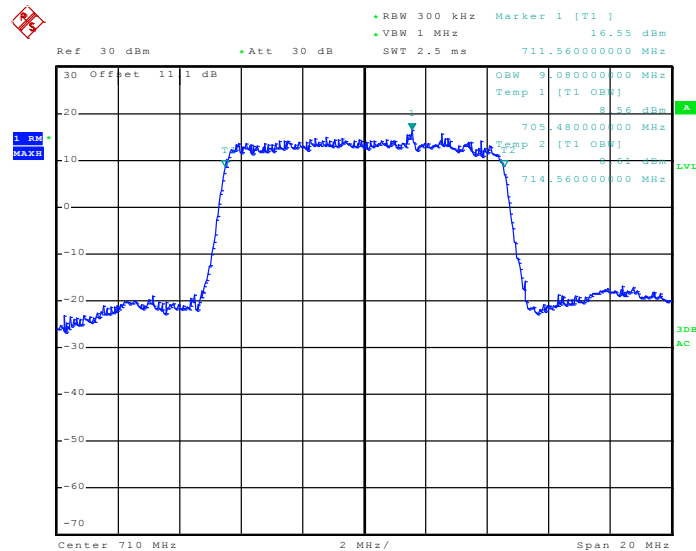

Date: 9.JUN.2011 23:04:55

3.4 Emission Mask Measurement

3.4.1 Limit

The emissions be operated in the 698 -746 MHz band, the FCC limit is $43 + 10\log_{10}(P[\text{Watts}]) \text{ dB} = -13 \text{ dBm}$ in a 100 kHz bandwidth.

For operations in the 1710 – 1755 MHz and 2110 – 2155 MHz bands , the FCC limit is $43 + 10\log_{10}(P[\text{Watts}]) \text{ dB} = -13 \text{ dBm}$ in a 1 MHz bandwidth.

3.4.2 Measuring Instruments

See list of measuring instruments of this test report.

3.4.3 Test Procedures

1. The EUT was connected to Spectrum Analyzer and Base Station via power divider.
2. The band edges of low and high channels for the highest RF powers were measured. Setting RBW as specify.

3.4.4 Test Setup

<Conducted Band Edge >

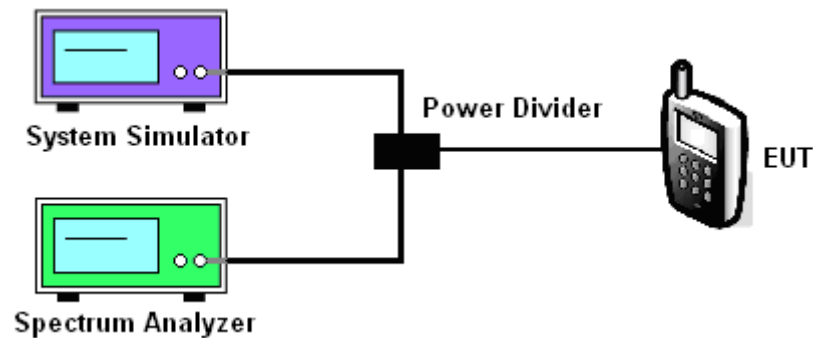



3.4.5 Test Result (Plots) of Conducted Band Edge

Band :	LTE Band 4	Band Width	5MHz
---------------	------------	-------------------	------

Lower Band Edge Plot for QPSK-RB Size 1, RB Offset 0

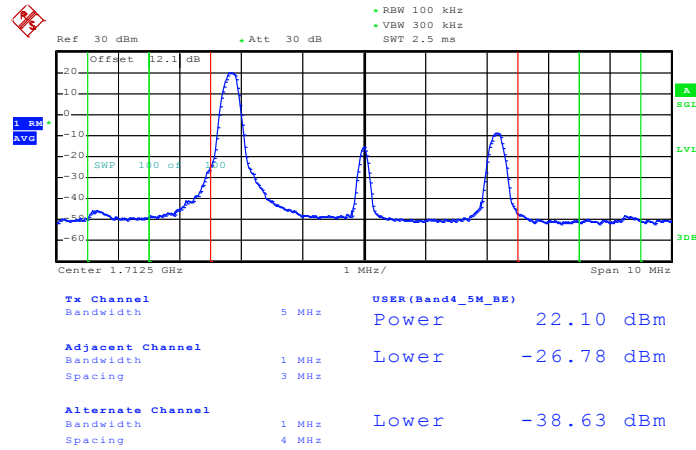

Date: 8.JUN.2011 20:54:16

Lower Band Edge Plot for QPSK-RB Size 25, RB Offset 0

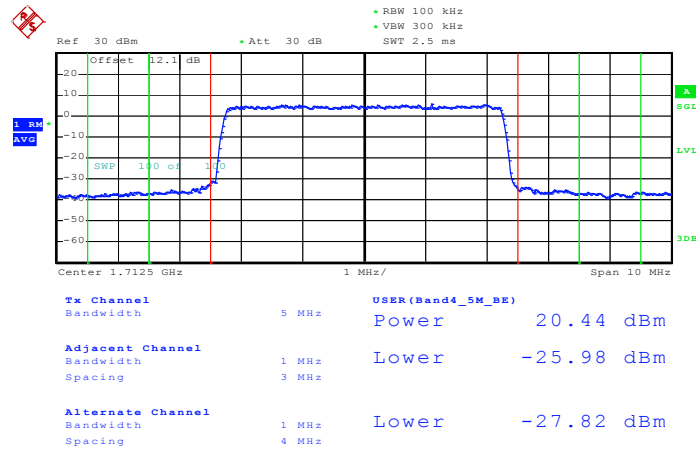

Date: 8.JUN.2011 20:53:18



Higher Band Edge Plot for QPSK-RB Size 1, RB Offset 24

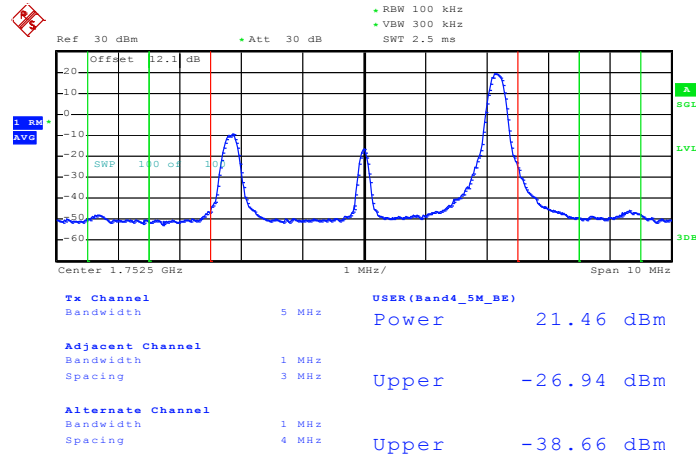

Date: 8.JUN.2011 20:57:22

Higher Band Edge Plot for QPSK-RB Size 25, RB Offset 0

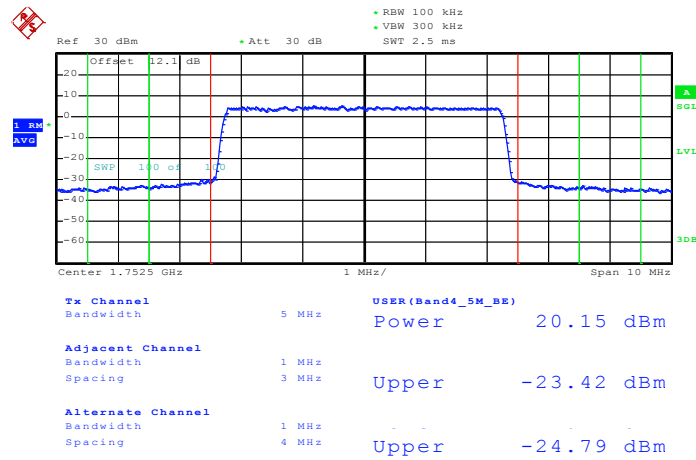

Date: 8.JUN.2011 20:56:24



Band :	LTE Band 4	Band Width	10MHz
---------------	------------	-------------------	-------

Lower Band Edge Plot for QPSK-RB Size 1, RB Offset 0

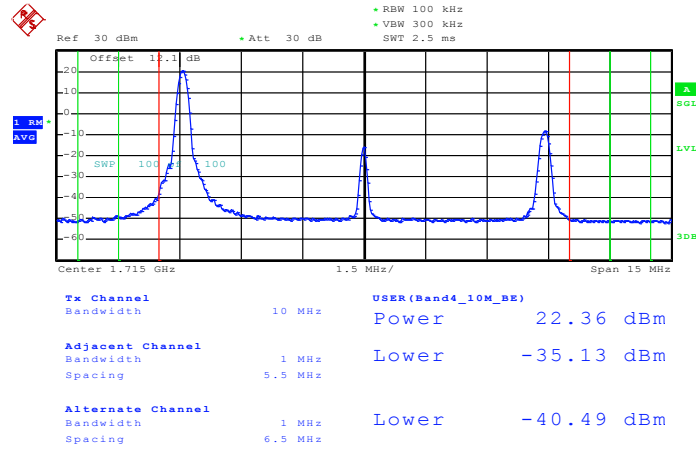

Date: 8.JUN.2011 20:46:06

Lower Band Edge Plot for QPSK-RB Size 50, RB Offset 0

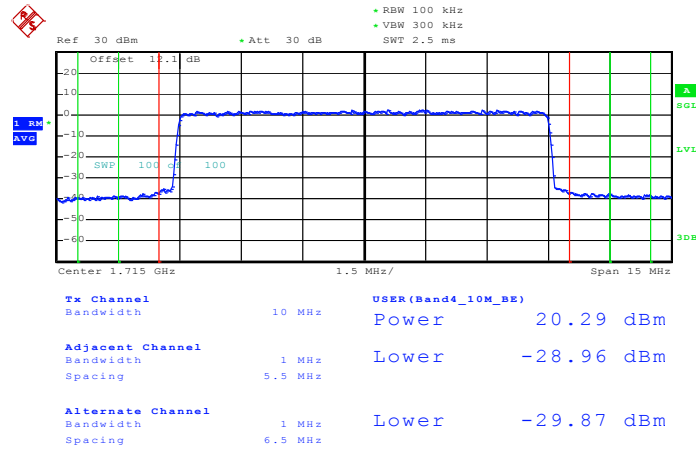

Date: 8.JUN.2011 20:44:57



Higher Band Edge Plot for QPSK-RB Size 1, RB Offset 49

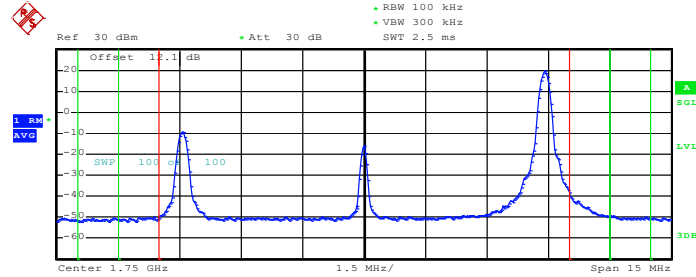

Tx Channel		USER (Band4_10M_BE)	
Bandwidth	10 MHz	Power	21.36 dBm
Adjacent Channel		Upper	-34.99 dBm
Bandwidth	1 MHz		
Spacing	5.5 MHz		
Alternate Channel		Upper	-40.57 dBm
Bandwidth	1 MHz		
Spacing	6.5 MHz		

Date: 8.JUN.2011 20:48:42

Higher Band Edge Plot for QPSK-RB Size 50, RB Offset 0

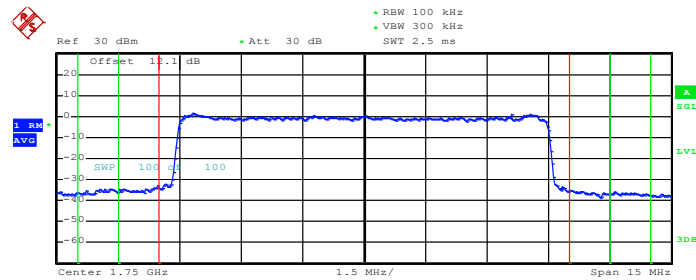

Tx Channel		USER (Band4_10M_BE)	
Bandwidth	10 MHz	Power	18.52 dBm
Adjacent Channel		Upper	-26.72 dBm
Bandwidth	1 MHz		
Spacing	5.5 MHz		
Alternate Channel		Upper	-27.25 dBm
Bandwidth	1 MHz		
Spacing	6.5 MHz		

Date: 8.JUN.2011 20:47:55



Band :	LTE Band 17	Band Width	5MHz
---------------	-------------	-------------------	------

Lower Band Edge Plot for QPSK-RB Size 1, RB Offset 0

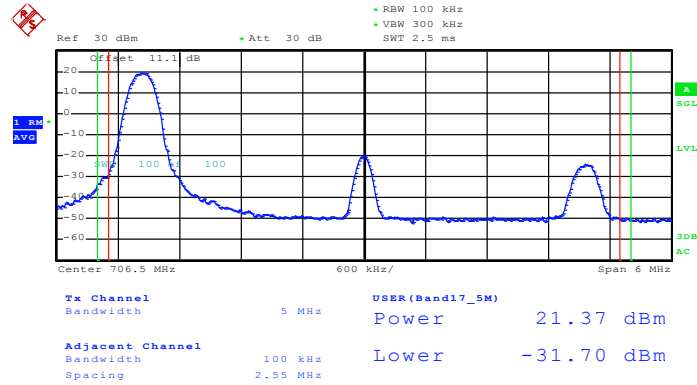

Date: 10.JUN.2011 00:29:42

Lower Band Edge Plot for QPSK-RB Size 25, RB Offset 0

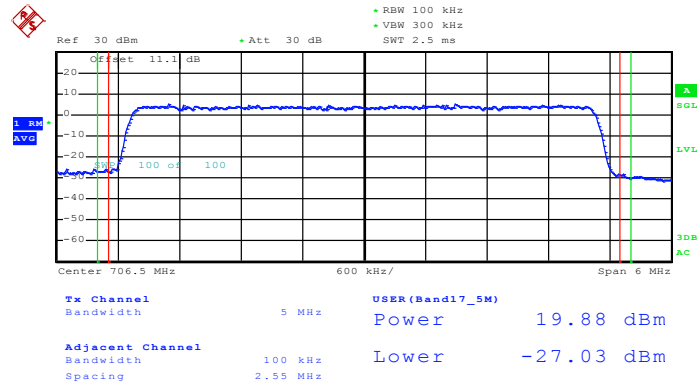

Date: 10.JUN.2011 00:30:24



Higher Band Edge Plot for QPSK-RB Size 1, RB Offset 24

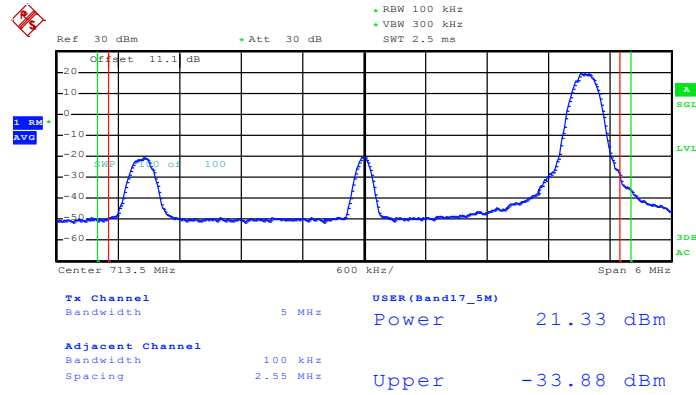

Date: 10.JUN.2011 00:56:47

Higher Band Edge Plot for QPSK-RB Size 25, RB Offset 0

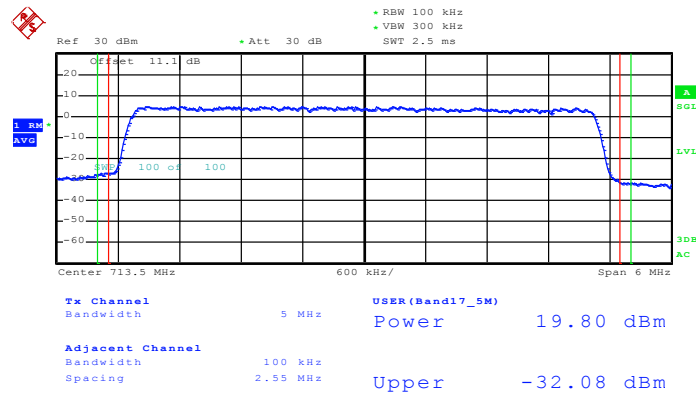

Date: 10.JUN.2011 00:54:15



Band :	LTE Band 17	Band Width	10MHz
---------------	-------------	-------------------	-------

Lower Band Edge Plot for QPSK-RB Size 1, RB Offset 0

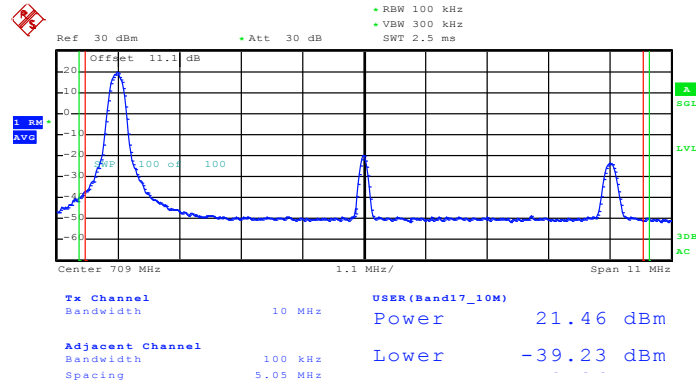

Date: 10.JUN.2011 01:07:22

Lower Band Edge Plot for QPSK-RB Size 50, RB Offset 0

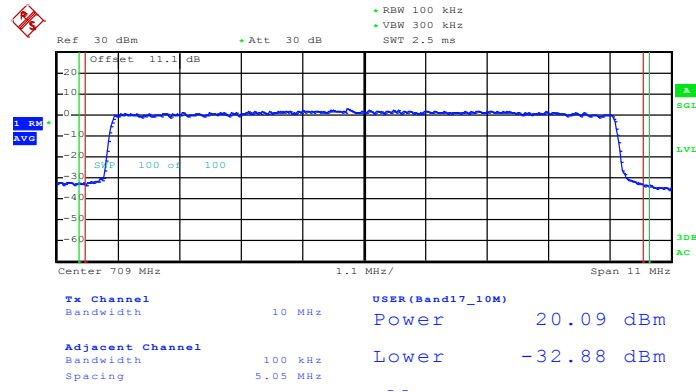

Date: 10.JUN.2011 00:44:46



Higher Band Edge Plot for QPSK-RB Size 1, RB Offset 49

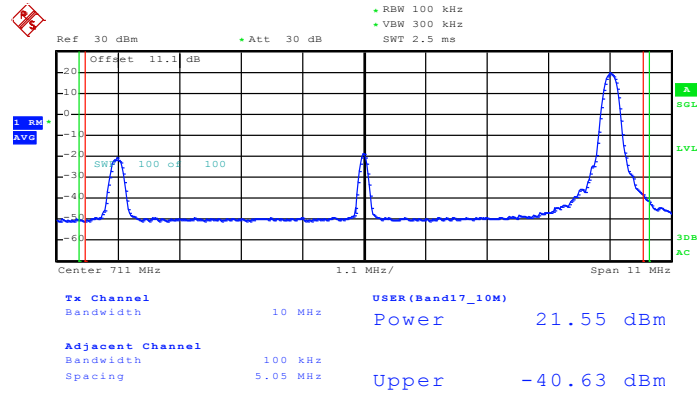

Date: 10.JUN.2011 01:25:47

Higher Band Edge Plot for QPSK-RB Size 50, RB Offset 0

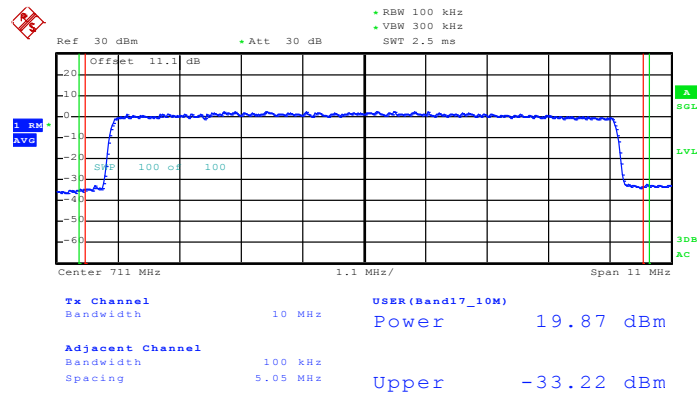

Date: 10.JUN.2011 00:47:23

3.5 Conducted Emission Measurement

3.5.1 Description of Conducted Emission Measurement

The power of any emission outside of the authorized operating frequency ranges must be lower than the transmitter power (P) by a factor of at least $43 + 10 \log (P)$ dB.

It is measured by means of a calibrated spectrum analyzer and scanned from 9 kHz up to a frequency including its 10th harmonic.

3.5.2 Measuring Instruments

See list of measuring instruments of this test report.

3.5.3 Test Procedures

1. The EUT was connected to spectrum analyzer and base station via power divider.
2. The middle channel for the highest RF power within the transmitting frequency was measured.
3. The conducted spurious emission for the whole frequency range was taken.

3.5.4 Test Setup

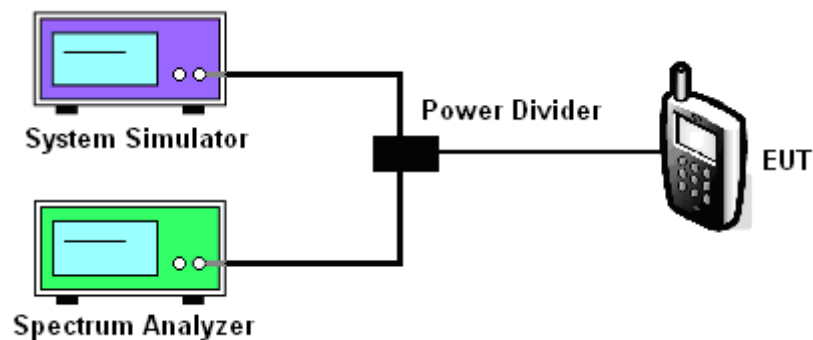

3.5.5 Test Result (Plots) of Conducted Emission

Band :	LTE Band 4	Channel :	CH19975
Band Width	5MHz		

Conducted Emission Plot (9kHz ~ 1GHz) for QPSK (RB Size 1, RB Offset 0)

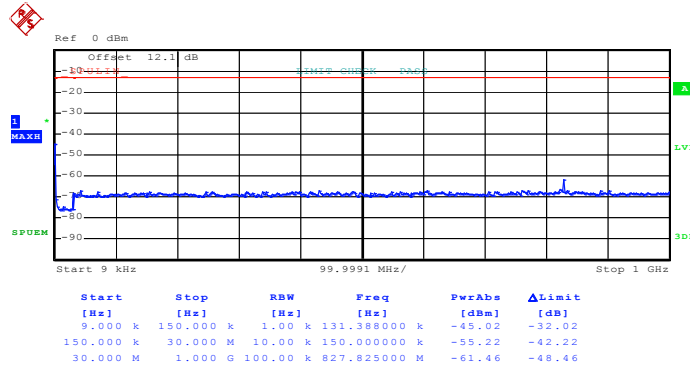

Date: 8.JUN.2011 22:20:01

Conducted Emission Plot (1GHz ~ 18GHz) for QPSK (RB Size 1, RB Offset 0)

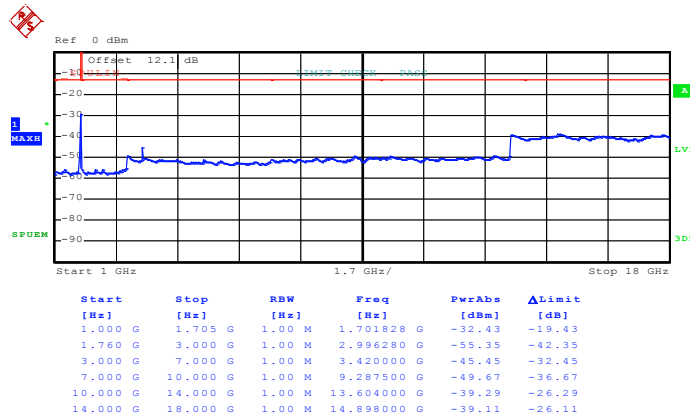

Date: 8.JUN.2011 22:16:58



Conducted Emission Plot (9kHz ~ 1GHz) for QPSK (RB Size 1, RB Offset 24)

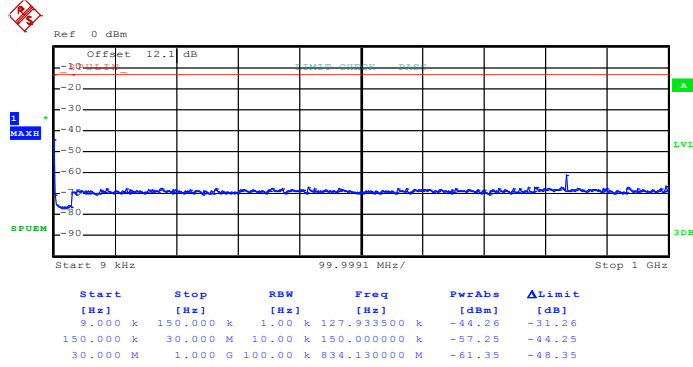

Date: 8.JUN.2011 22:19:10

Conducted Emission Plot (1GHz ~ 18GHz) for QPSK (RB Size 1, RB Offset 24)

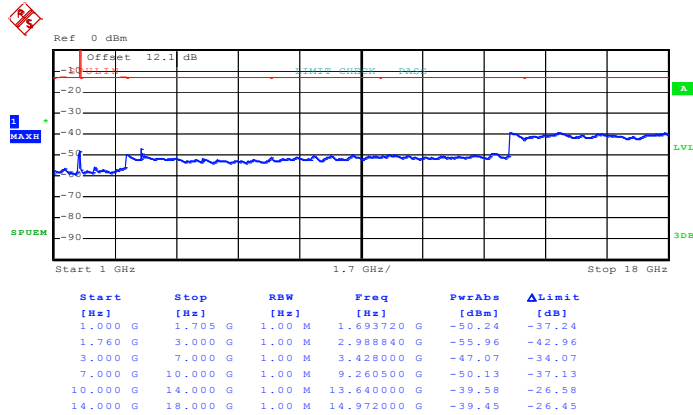

Date: 8.JUN.2011 22:17:52



Band :	LTE Band 4	Channel :	CH20175
Band Width	5MHz		

Conducted Emission Plot (9kHz ~ 1GHz) for QPSK (RB Size 1, RB Offset 0)

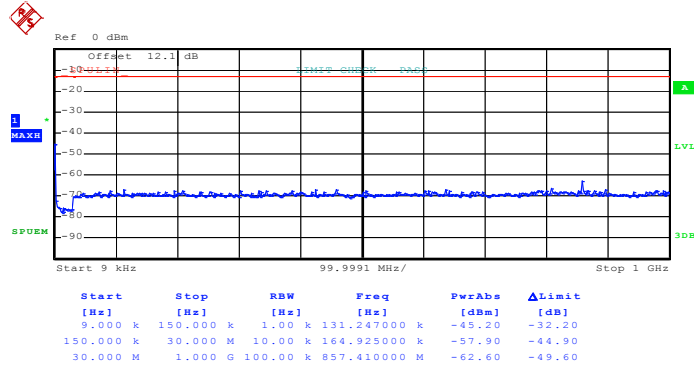

Date: 8.JUN.2011 22:21:40

Conducted Emission Plot (1GHz ~ 18GHz) for QPSK (RB Size 1, RB Offset 0)

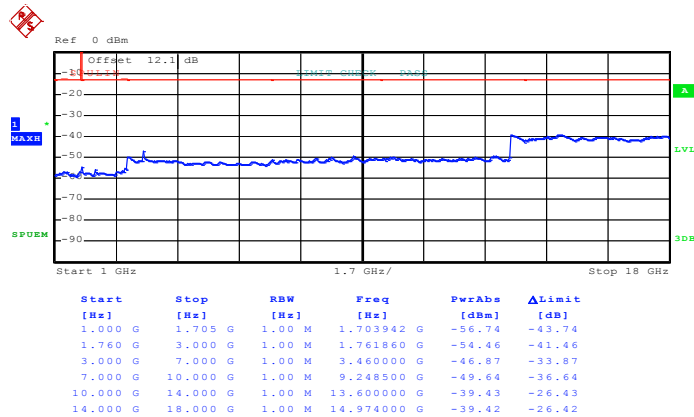

Date: 8.JUN.2011 22:24:11



Conducted Emission Plot (9kHz ~ 1GHz) for QPSK (RB Size 1, RB Offset 24)

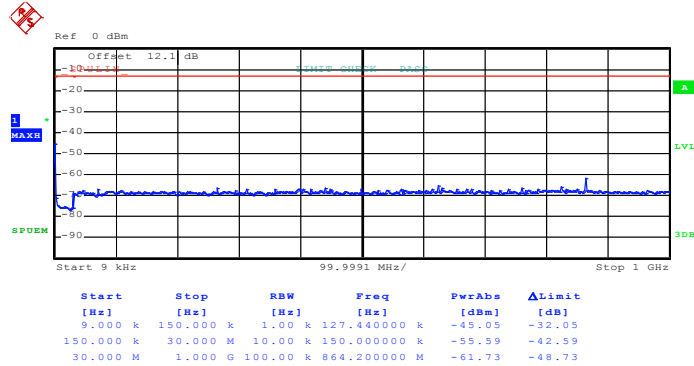

Date: 8.JUN.2011 22:22:38

Conducted Emission Plot (1GHz ~ 18GHz) for QPSK (RB Size 1, RB Offset 24)

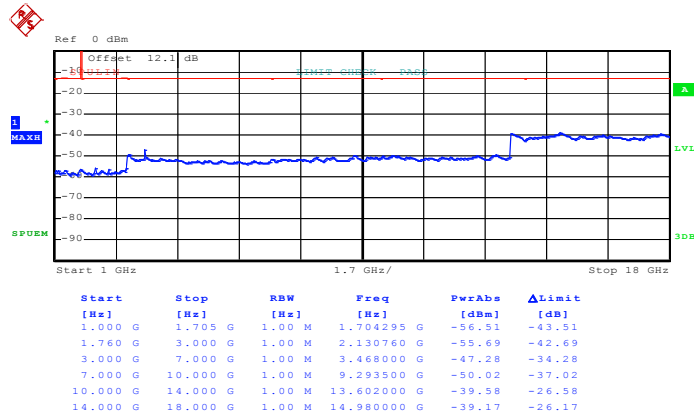

Date: 8.JUN.2011 22:23:29



Band :	LTE Band 4	Channel :	CH20375
Band Width	5MHz		

Conducted Emission Plot (9kHz ~ 1GHz) for QPSK (RB Size 1, RB Offset 0)

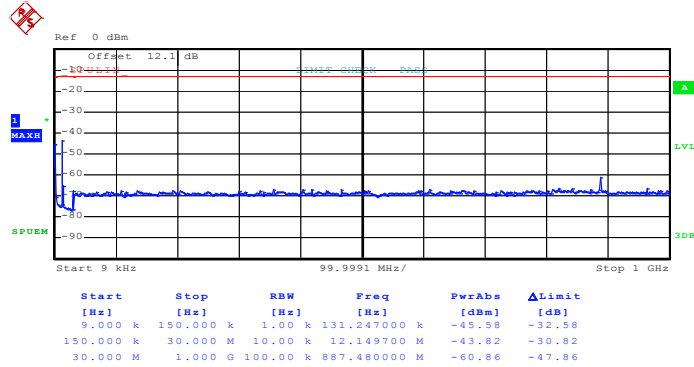

Date: 8.JUN.2011 22:28:21

Conducted Emission Plot (1GHz ~ 18GHz) for QPSK (RB Size 1, RB Offset 0)

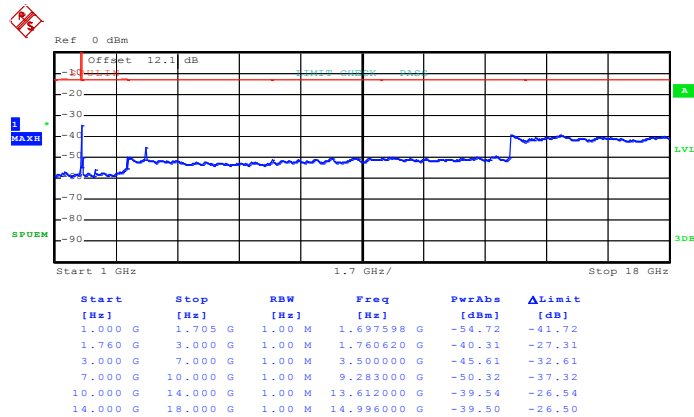

Date: 8.JUN.2011 22:25:46



Conducted Emission Plot (9kHz ~ 1GHz) for QPSK (RB Size 1, RB Offset 24)

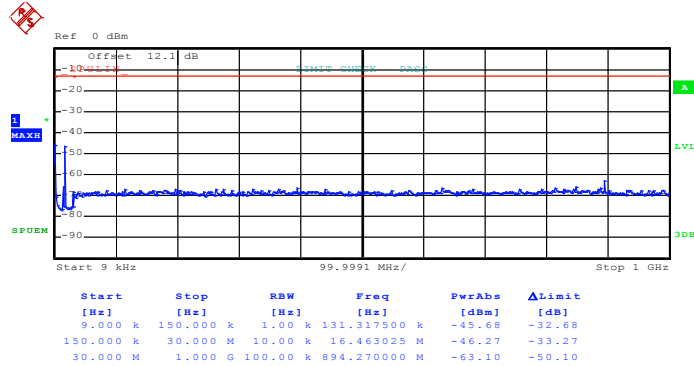

Date: 8.JUN.2011 22:27:38

Conducted Emission Plot (1GHz ~ 18GHz) for QPSK (RB Size 1, RB Offset 24)

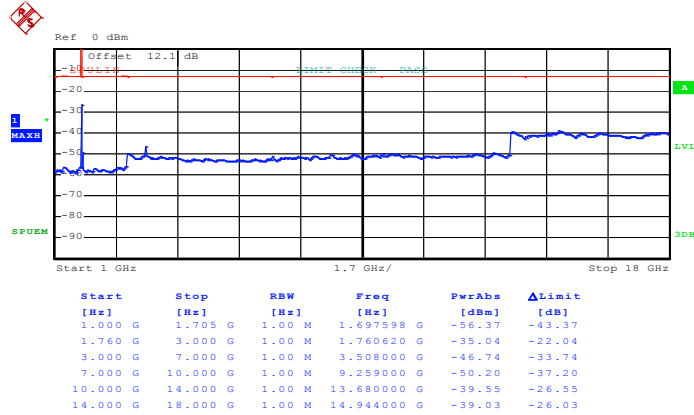

Date: 8.JUN.2011 22:26:34



Band :	LTE Band 4	Channel :	CH20000
Band Width	10MHz		

Conducted Emission Plot (9kHz ~ 1GHz) for QPSK (RB Size 1, RB Offset 0)

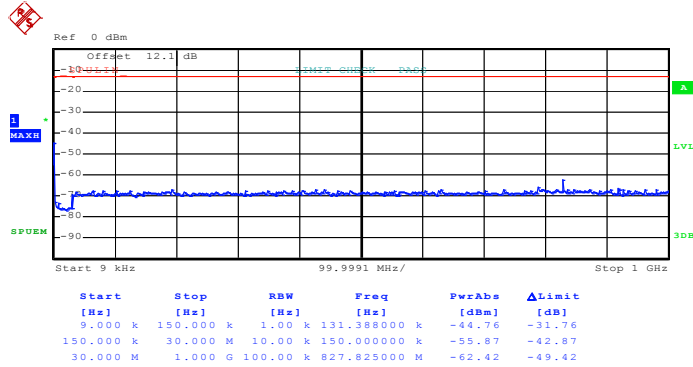

Date: 8.JUN.2011 22:54:51

Conducted Emission Plot (1GHz ~ 18GHz) for QPSK (RB Size 1, RB Offset 0)

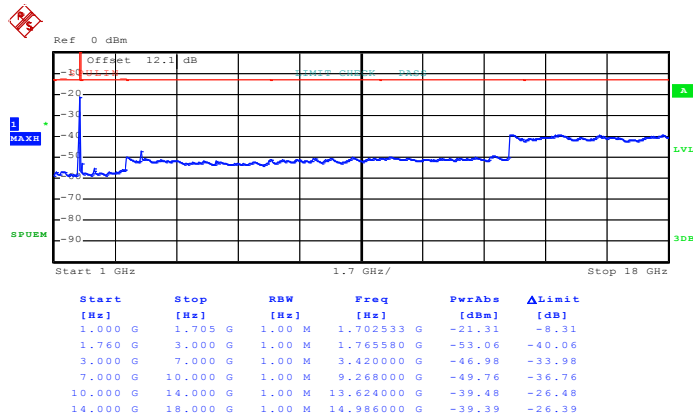

Date: 8.JUN.2011 22:47:36



Conducted Emission Plot (9kHz ~ 1GHz) for QPSK (RB Size 1, RB Offset 49)

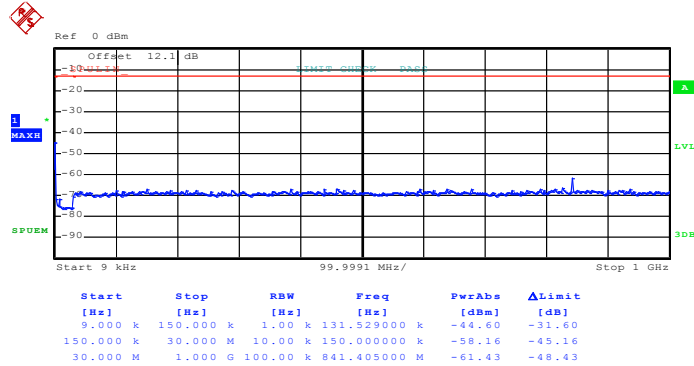

Date: 8.JUN.2011 22:54:13

Conducted Emission Plot (1GHz ~ 18GHz) for QPSK (RB Size 1, RB Offset 49)

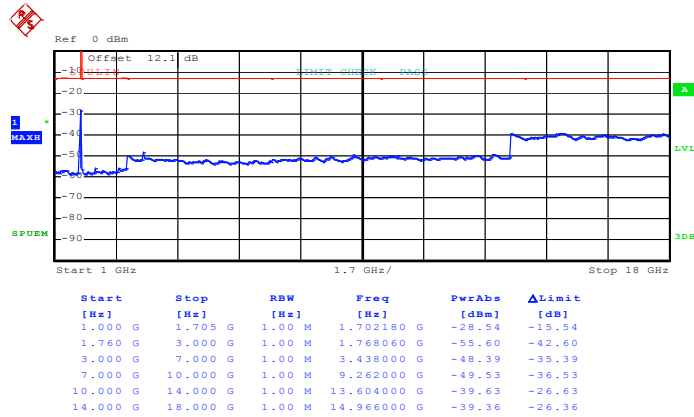

Date: 8.JUN.2011 22:48:13



Band :	LTE Band 4	Channel :	CH20175
Band Width	10MHz		

Conducted Emission Plot (9kHz ~ 1GHz) for QPSK (RB Size 1, RB Offset 0)

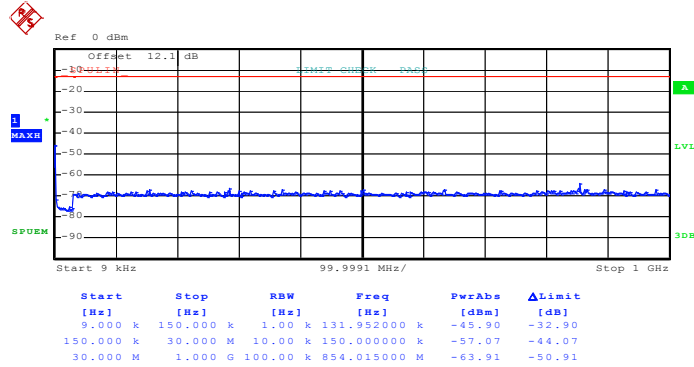

Date: 8.JUN.2011 22:52:47

Conducted Emission Plot (1GHz ~ 18GHz) for QPSK (RB Size 1, RB Offset 0)

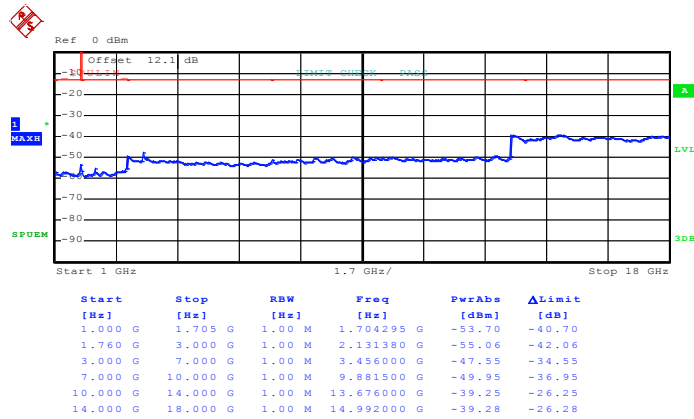

Date: 8.JUN.2011 22:49:39



Conducted Emission Plot (9kHz ~ 1GHz) for QPSK (RB Size 1, RB Offset 49)

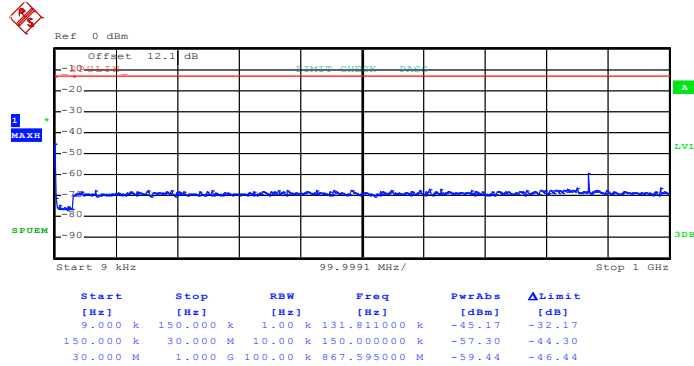

Date: 8.JUN.2011 22:53:17

Conducted Emission Plot (1GHz ~ 18GHz) for QPSK (RB Size 1, RB Offset 49)

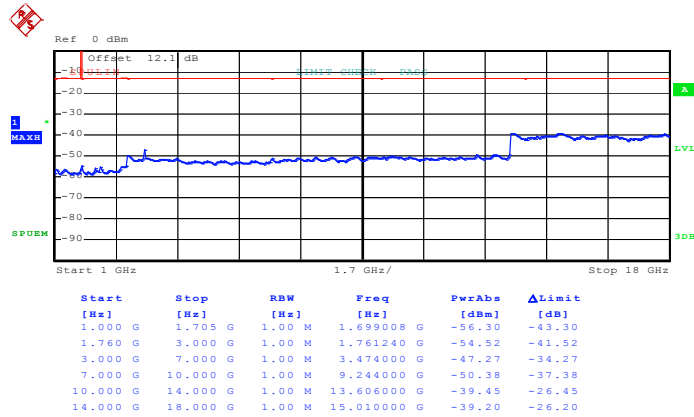

Date: 8.JUN.2011 22:49:05



Band :	LTE Band 4	Channel :	CH20350
Band Width	10MHz		

Conducted Emission Plot (9kHz ~ 1GHz) for QPSK (RB Size 1, RB Offset 0)

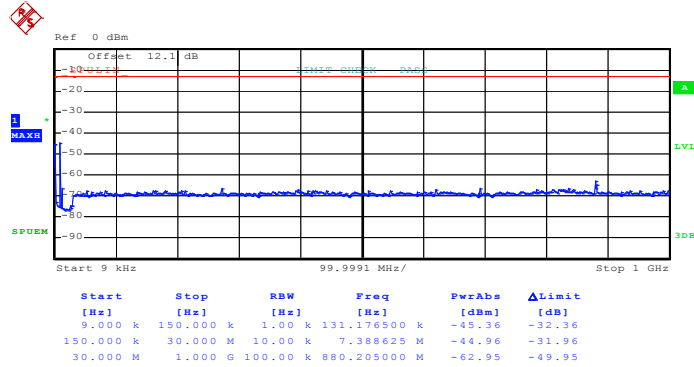

Date: 8.JUN.2011 22:52:05

Conducted Emission Plot (1GHz ~ 18GHz) for QPSK (RB Size 1, RB Offset 0)

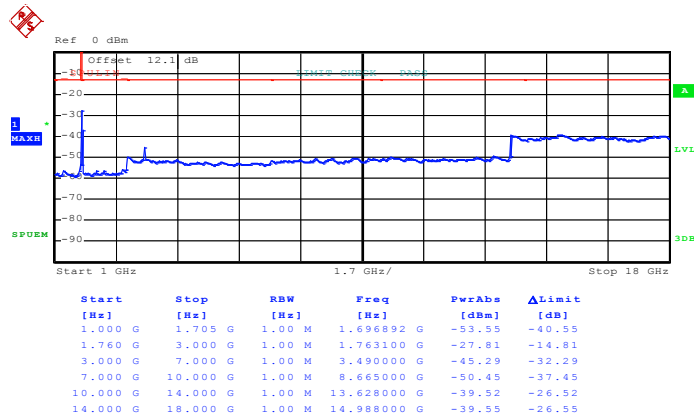

Date: 8.JUN.2011 22:50:29



Conducted Emission Plot (9kHz ~ 1GHz) for QPSK (RB Size 1, RB Offset 49)

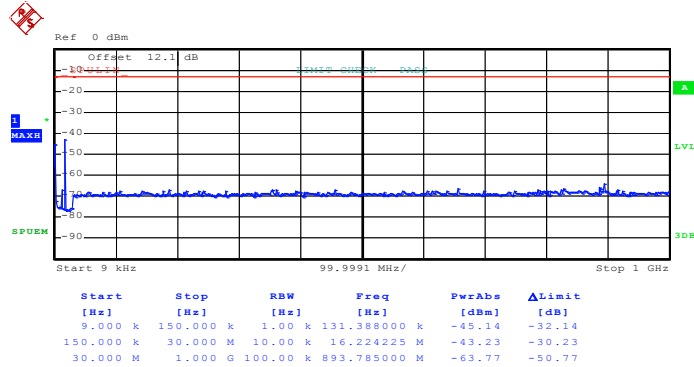

Date: 8.JUN.2011 22:51:34

Conducted Emission Plot (1GHz ~ 18GHz) for QPSK (RB Size 1, RB Offset 49)

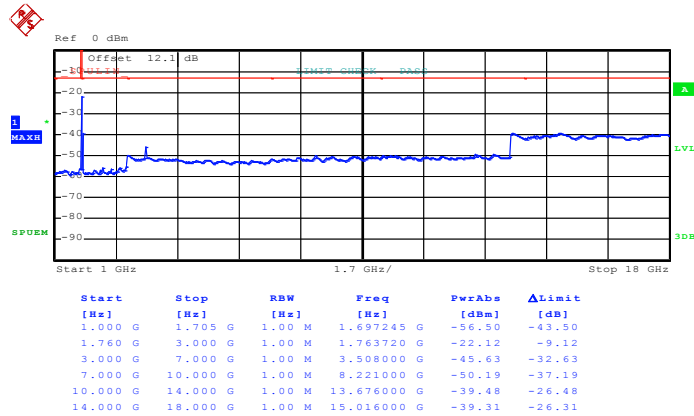

Date: 8.JUN.2011 22:51:01



Band :	LTE Band 17	Channel :	CH23755
Band Width	5MHz		

Conducted Emission Plot (9kHz ~ 1GHz) for QPSK (RB Size 1, RB Offset 0)

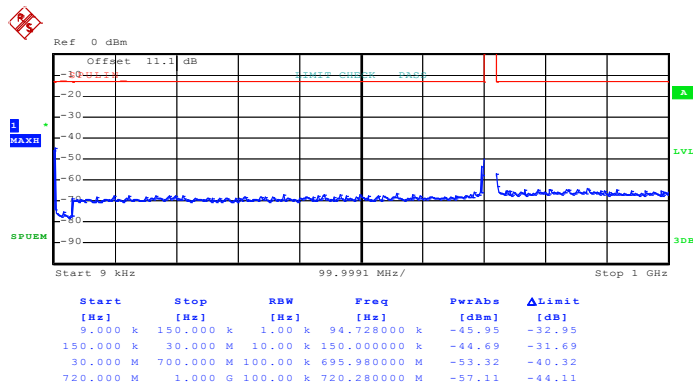

Date: 9.JUN.2011 00:19:16

Conducted Emission Plot (1GHz ~ 8GHz) for QPSK (RB Size 1, RB Offset 0)

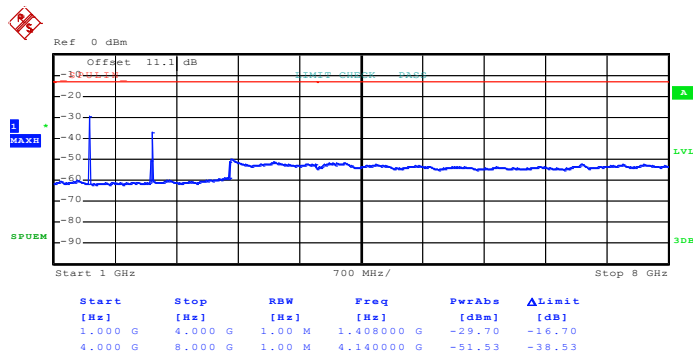

Date: 9.JUN.2011 00:25:50



Conducted Emission Plot (9kHz ~ 1GHz) for QPSK (RB Size 1, RB Offset 24)

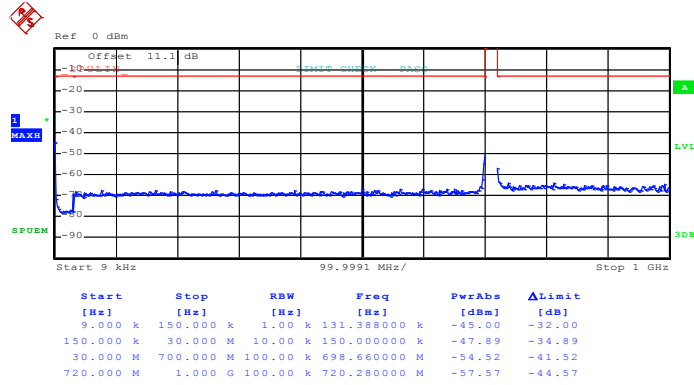

Date: 9.JUN.2011 00:19:48

Conducted Emission Plot (1GHz ~ 8GHz) for QPSK (RB Size 1, RB Offset 24)

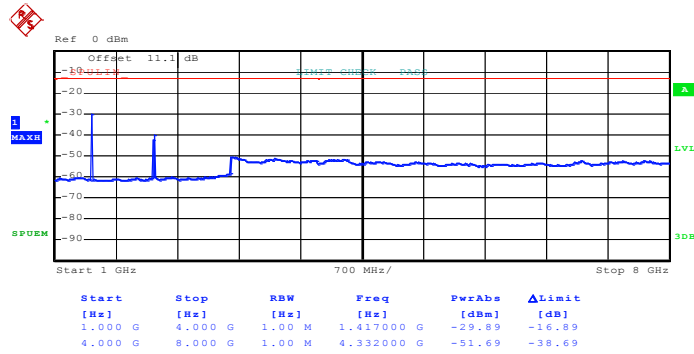

Date: 9.JUN.2011 00:25:24



Band :	LTE Band 17	Channel :	CH23790
Band Width	5MHz		

Conducted Emission Plot (9kHz ~ 1GHz) for QPSK (RB Size 1, RB Offset 0)

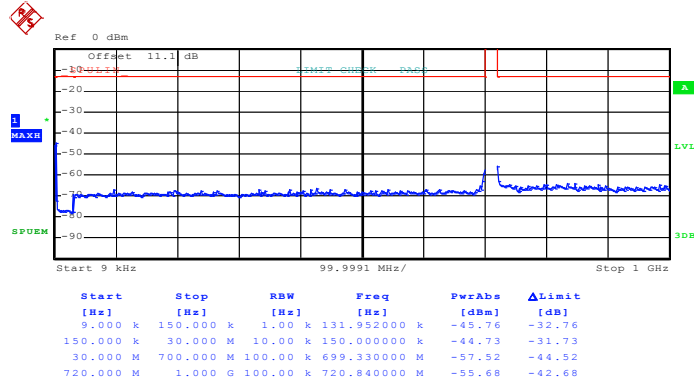

Date: 9.JUN.2011 00:21:01

Conducted Emission Plot (1GHz ~ 8GHz) for QPSK (RB Size 1, RB Offset 0)

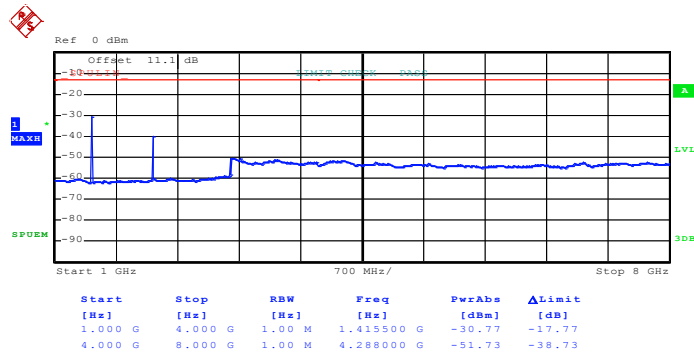

Date: 9.JUN.2011 00:23:58



Conducted Emission Plot (9kHz ~ 1GHz) for QPSK (RB Size 1, RB Offset 24)

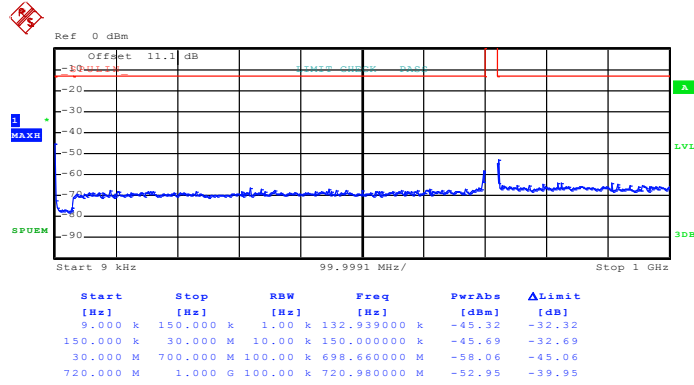

Date: 9.JUN.2011 00:20:27

Conducted Emission Plot (1GHz ~ 8GHz) for QPSK (RB Size 1, RB Offset 24)

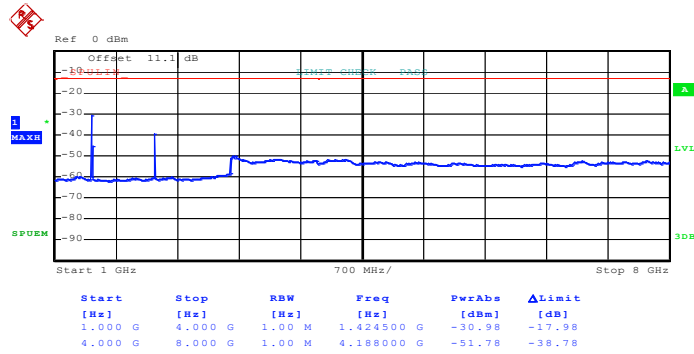

Date: 9.JUN.2011 00:24:28



Band :	LTE Band 17	Channel :	CH23825
Band Width	5MHz		

Conducted Emission Plot (9kHz ~ 1GHz) for QPSK (RB Size 1, RB Offset 0)

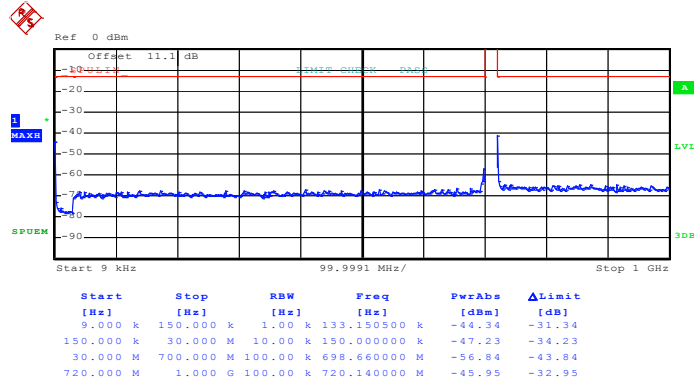

Date: 9.JUN.2011 00:21:43

Conducted Emission Plot (1GHz ~ 8GHz) for QPSK (RB Size 1, RB Offset 0)

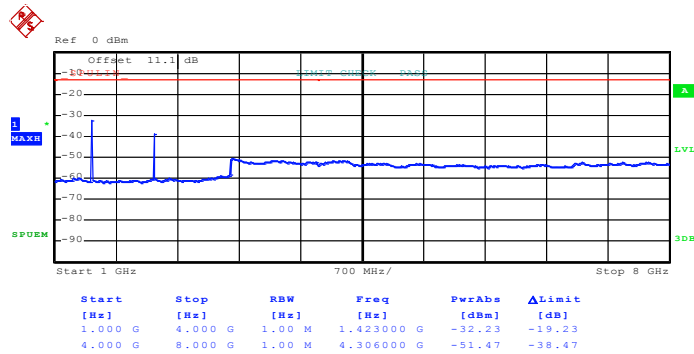

Date: 9.JUN.2011 00:23:18



Conducted Emission Plot (9kHz ~ 1GHz) for QPSK (RB Size 1, RB Offset 24)

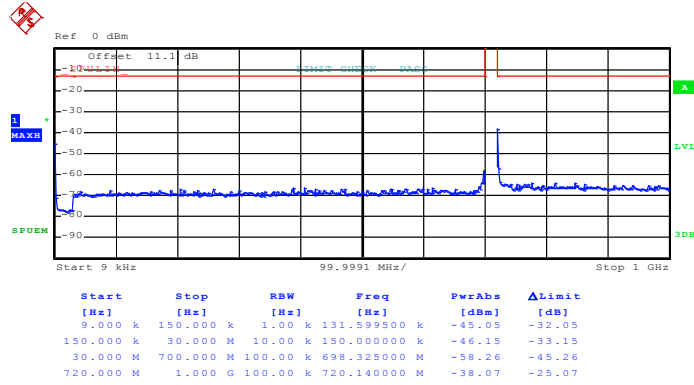

Date: 9.JUN.2011 00:22:18

Conducted Emission Plot (1GHz ~ 8GHz) for QPSK (RB Size 1, RB Offset 24)

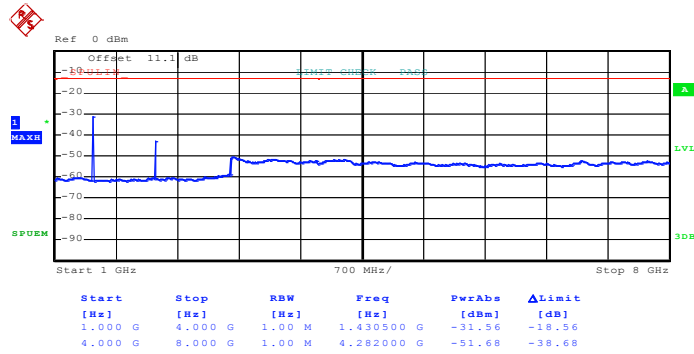

Date: 9.JUN.2011 00:22:50



Band :	LTE Band 17	Channel :	CH23780
Band Width	10MHz		

Conducted Emission Plot (9kHz ~ 1GHz) for QPSK (RB Size 1, RB Offset 0)

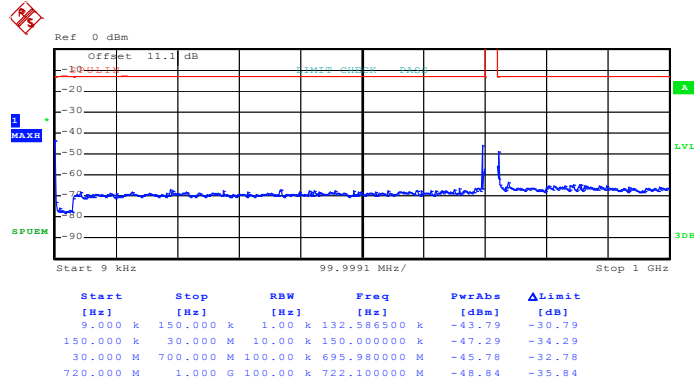

Date: 9.JUN.2011 00:17:57

Conducted Emission Plot (1GHz ~ 8GHz) for QPSK (RB Size 1, RB Offset 0)

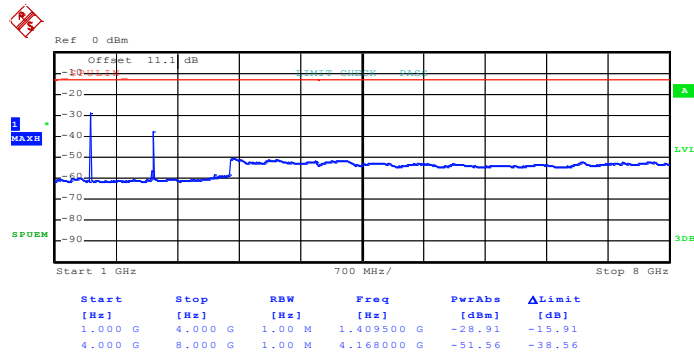

Date: 9.JUN.2011 00:11:03



Conducted Emission Plot (9kHz ~ 1GHz) for QPSK (RB Size 1, RB Offset 49)

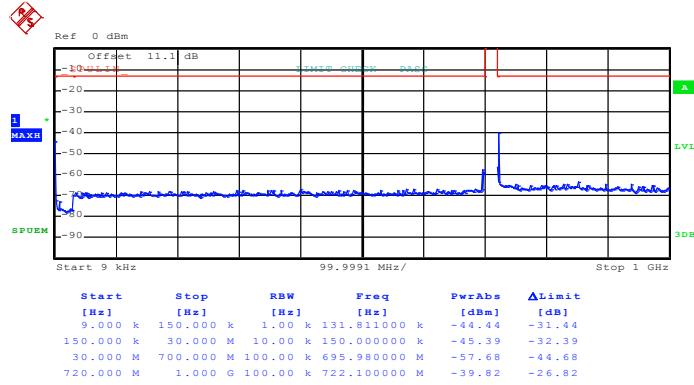

Date: 9.JUN.2011 00:17:30

Conducted Emission Plot (1GHz ~ 8GHz) for QPSK (RB Size 1, RB Offset 49)

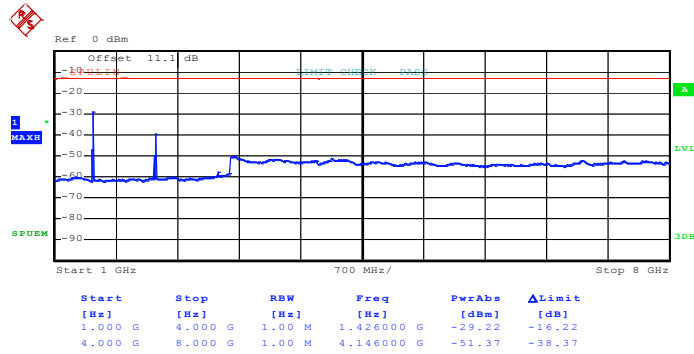

Date: 9.JUN.2011 00:11:34



Band :	LTE Band 17	Channel :	CH23790
Band Width	10MHz		

Conducted Emission Plot (9kHz ~ 1GHz) for QPSK (RB Size 1, RB Offset 0)

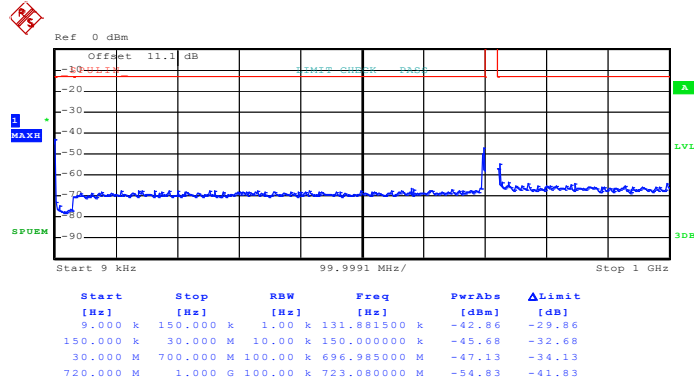

Date: 9.JUN.2011 00:16:18

Conducted Emission Plot (1GHz ~ 8GHz) for QPSK (RB Size 1, RB Offset 0)

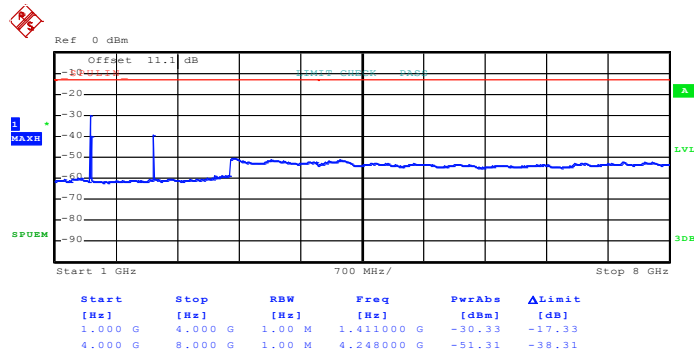

Date: 9.JUN.2011 00:13:21



Conducted Emission Plot (9kHz ~ 1GHz) for QPSK (RB Size 1, RB Offset 49)

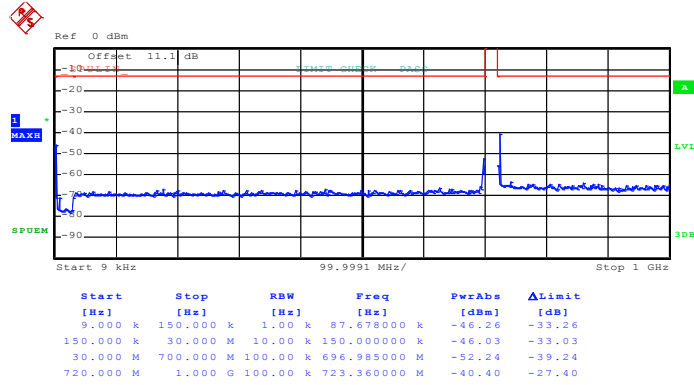

Date: 9.JUN.2011 00:16:51

Conducted Emission Plot (1GHz ~ 8GHz) for QPSK (RB Size 1, RB Offset 49)

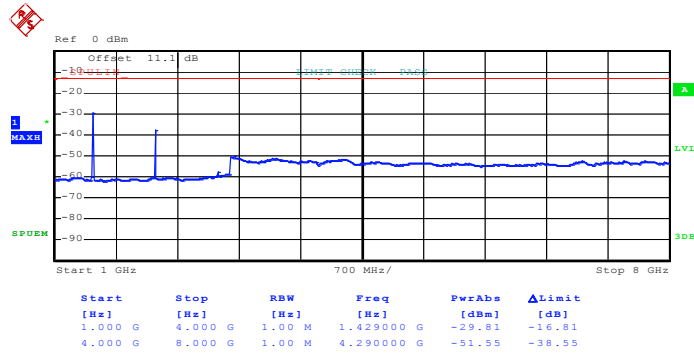

Date: 9.JUN.2011 00:12:51



Band :	LTE Band 17	Channel :	CH23800
Band Width	10MHz		

Conducted Emission Plot (9kHz ~ 1GHz) for QPSK (RB Size 1, RB Offset 0)

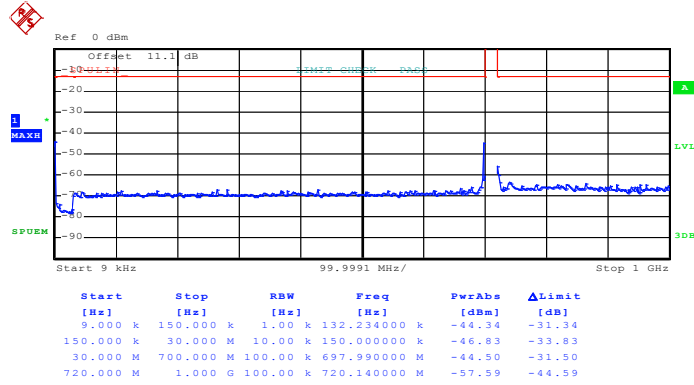

Date: 9.JUN.2011 00:15:34

Conducted Emission Plot (1GHz ~ 8GHz) for QPSK (RB Size 1, RB Offset 0)

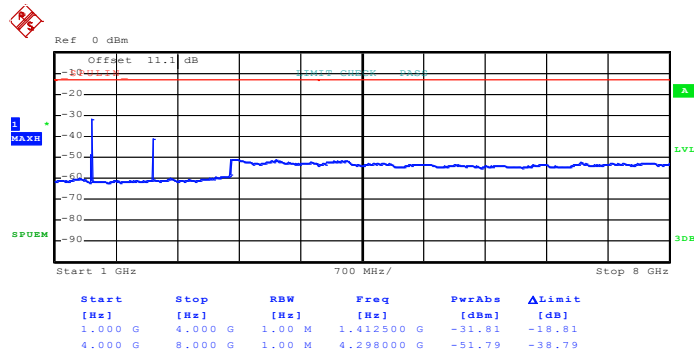

Date: 9.JUN.2011 00:14:03



Conducted Emission Plot (9kHz ~ 1GHz) for QPSK (RB Size 1, RB Offset 49)

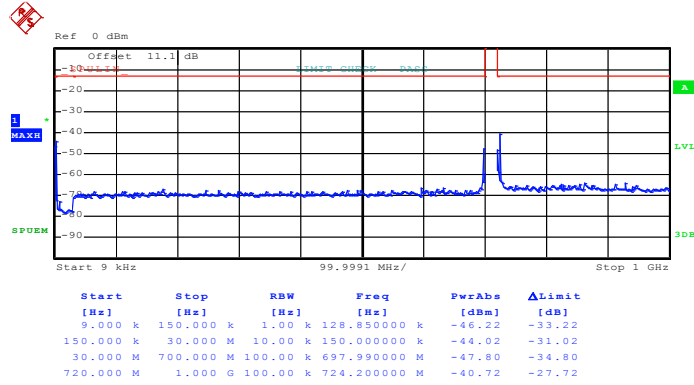

Date: 9.JUN.2011 00:15:04

Conducted Emission Plot (1GHz ~ 8GHz) for QPSK (RB Size 1, RB Offset 49)

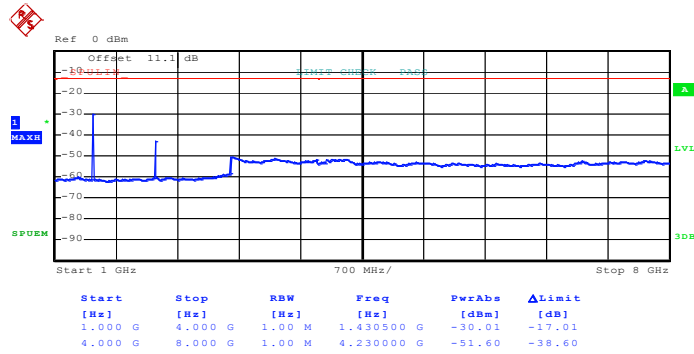

Date: 9.JUN.2011 00:14:33



3.6 Field Strength of Spurious Radiation Measurement

3.6.1 Description of Field Strength of Spurious Radiated Measurement

The radiated spurious emission was measured by substitution method according to ANSI / TIA / EIA-603-C-2004. The power of any emission outside of the authorized operating frequency ranges must be attenuated below the transmitter power (P) by a factor of at least $43 + 10 \log (P)$ dB. The spectrum is scanned from 30 MHz up to a frequency including its 10th harmonic.

3.6.2 Measuring Instruments

See list of measuring instruments of this test report.

3.6.3 Test Procedures

1. The EUT was placed on a rotatable wooden table with 0.8 meter about ground.
2. The EUT was set 3 meters from the receiving antenna, which was mounted on the antenna tower.
3. The table was rotated 360 degrees to determine the position of the highest spurious emission.
4. The height of the receiving antenna is varied between one meter and four meters to search the maximum spurious emission for both horizontal and vertical polarizations.
5. Make the measurement with the spectrum analyzer's RBW = 1MHz, VBW = 3MHz, Sweep = 500ms, Taking the record of maximum spurious emission.
6. A horn antenna was substituted in place of the EUT and was driven by a signal generator.
7. Tune the output power of signal generator to the same emission level with EUT maximum spurious emission.
8. Taking the record of output power at antenna port.
9. Repeat step 7 to step 8 for another polarization.
10. Emission level (dBm) = output power + substitution Gain.

3.6.4 Test Setup

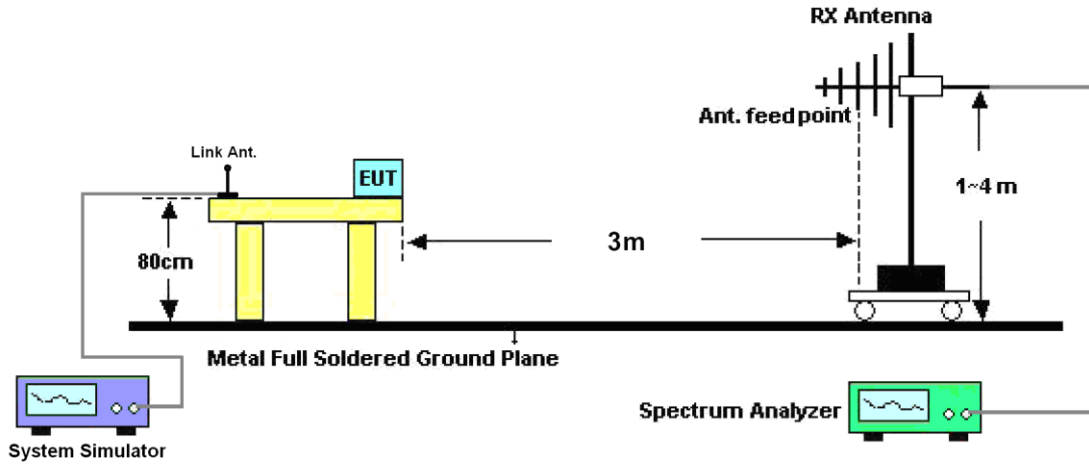



3.6.5 Test Result of Field Strength of Spurious Radiated

Band :	LTE Band 4	Temperature :	20~25°C
Test Mode :	5MHZ QPSK RB Size 1	Relative Humidity :	45~53%
Test Engineer :	David Yang	Polarization :	Horizontal
Remark :	Spurious emissions within 30-10th harmonic were found more than 20dB below limit line.		

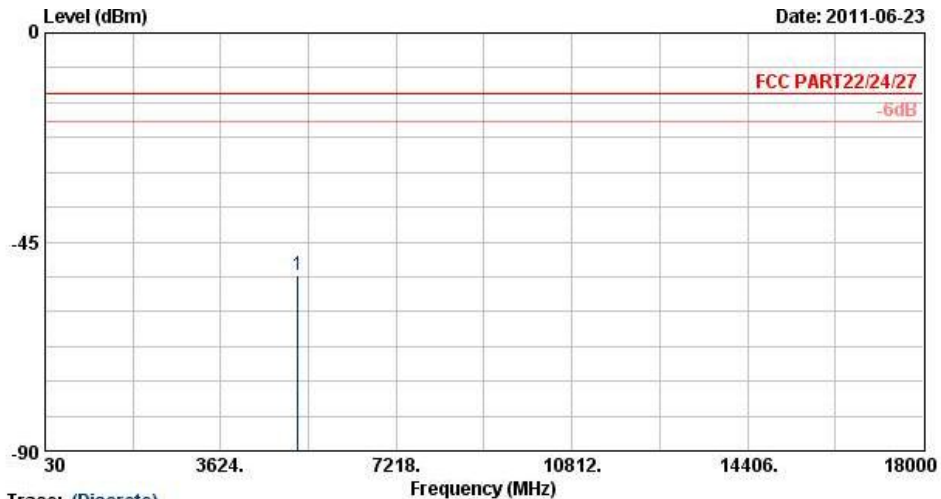

Trace: (Discrete)
 Site : 03CH07-HY
 Condition : FCC PART22/24/27 HF-ETRP(060306) HORIZONTAL
 Project : FG 132945

Frequency (MHz)	EIRP (dBm)	Limit (dBm)	Over Limit (dB)	SPA Reading (dBm)	S.G. Power (dBm)	TX Cable loss (dB)	TX Antenna Gain (dBi)	Polarization (H/V)	Result
5197	-52.34	-13	-39.34	-70.92	-54.83	5.332	9.98	H	Pass



Band :	LTE Band 4	Temperature :	22~25°C
Test Mode :	5MHZ QPSK RB Size 1	Relative Humidity :	45~50%
Test Engineer :	David Yang	Polarization :	Vertical
Remark :	Spurious emissions within 30MHz ~ 10th harmonic were not found any signals.		

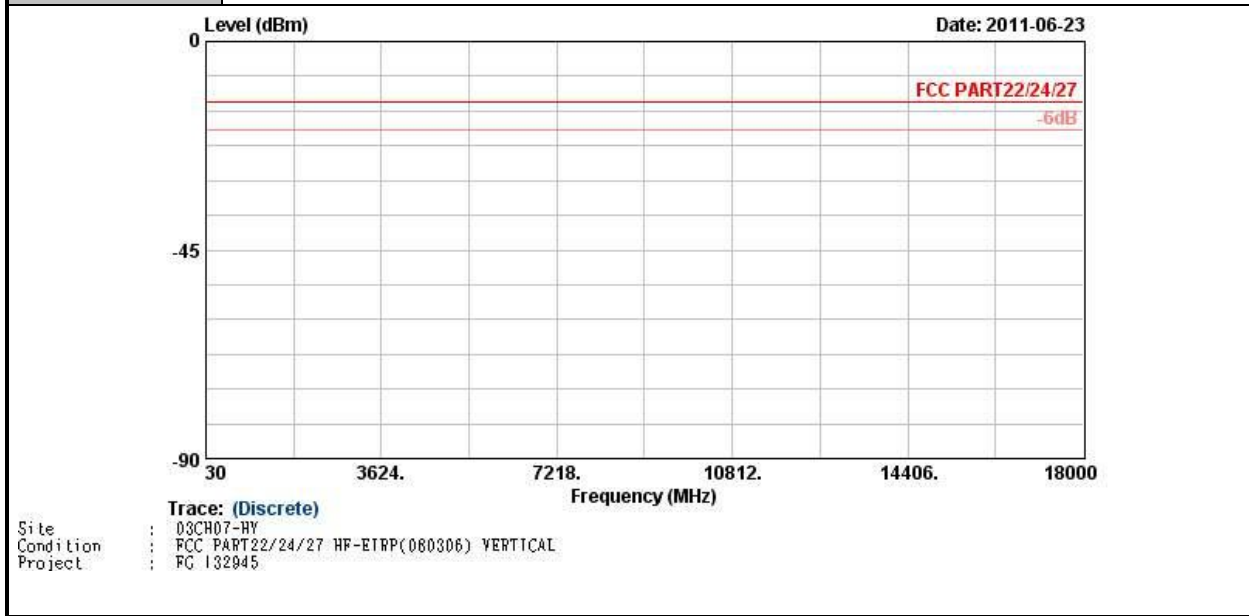



Band :	LTE Band 4	Temperature :	22~25°C
Test Mode :	5MHZ 16QAM RB Size 1	Relative Humidity :	45~50%
Test Engineer :	David Yang	Polarization :	Horizontal
Remark :	Spurious emissions within 30MHz ~ 10th harmonic were not found any signals.		

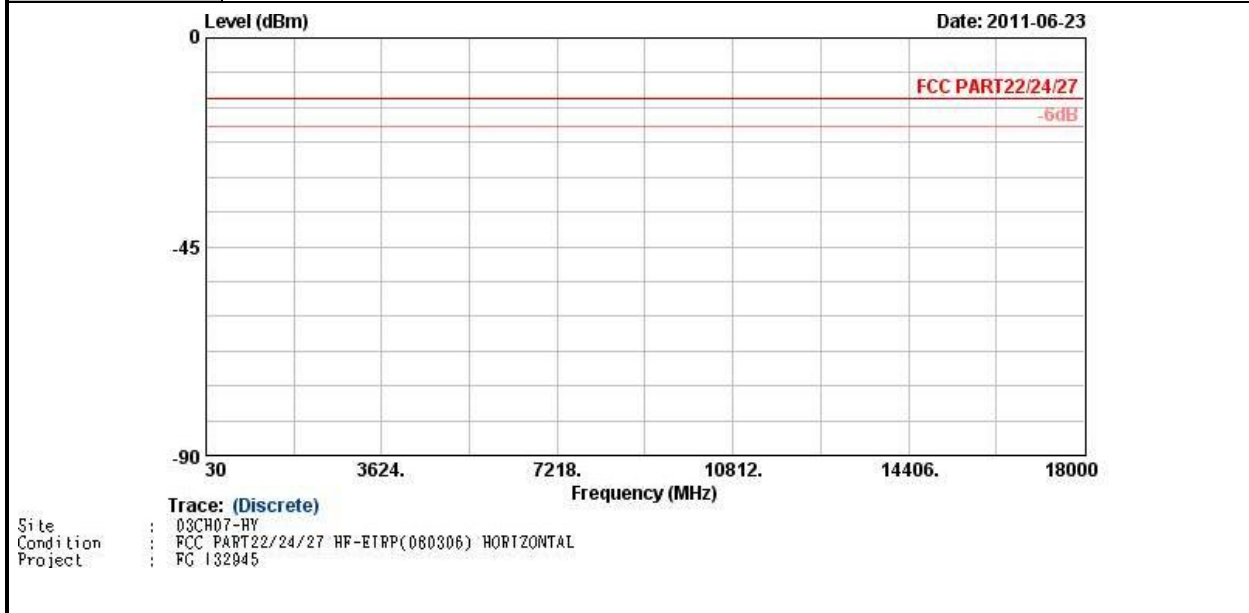



Band :	LTE Band 4	Temperature :	22~25°C
Test Mode :	5MHZ 16QAM RB Size 1	Relative Humidity :	45~50%
Test Engineer :	David Yang	Polarization :	Vertical
Remark :	Spurious emissions within 30-10th harmonic were found more than 20dB below limit line.		

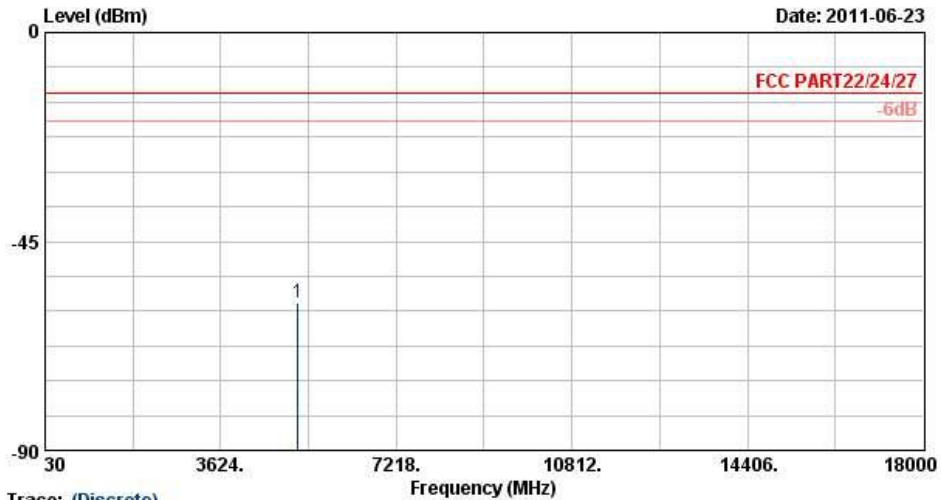

Trace: (Discrete)
 Site : 03CH07-HY
 Condition : FCC PART22/24/27 HF-ETRP(060306) VERTICAL
 Project : FG 132945

Frequency (MHz)	EIRP (dBm)	Limit (dBm)	Over Limit (dB)	SPA Reading (dBm)	S.G. Power (dBm)	TX Cable loss (dB)	TX Antenna Gain (dBi)	Polarization (H/V)	Result
5197	-58.25	-13	-45.25	-77.06	-60.74	5.332	9.98	V	Pass



Band :	LTE Band 4	Temperature :	22~25°C
Test Mode :	10MHZ QPSK RB Size 1	Relative Humidity :	45~50%
Test Engineer :	David Yang	Polarization :	Horizontal
Remark :	Spurious emissions within 30-10th harmonic were found more than 20dB below limit line.		

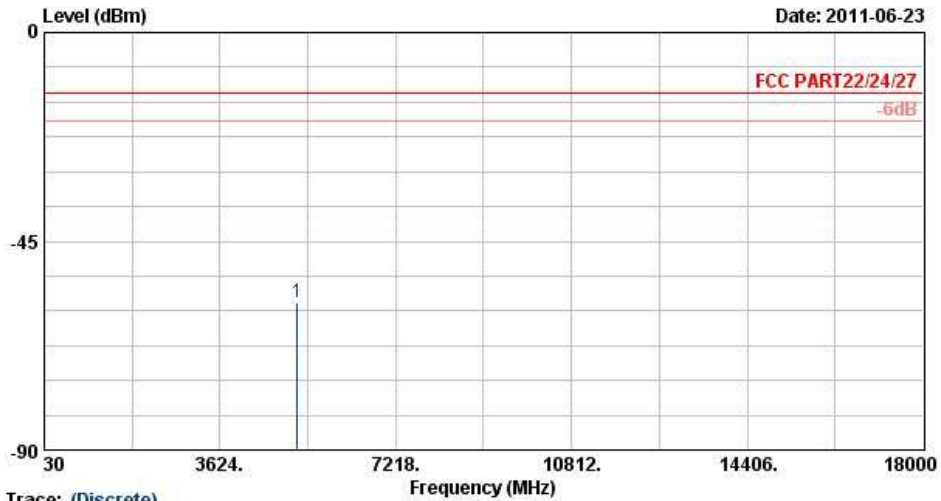

Trace: (Discrete)
 Site : 03CH07-HY
 Condition : FCC PART22/24/27 HF-ETRP(060306) HORIZONTAL
 Project : FG 132945

Frequency (MHz)	EIRP (dBm)	Limit (dBm)	Over Limit (dB)	SPA Reading (dBm)	S.G. Power (dBm)	TX Cable loss (dB)	TX Antenna Gain (dBi)	Polarization (H/V)	Result
5197	-58.08	-13	-45.08	-78.21	-60.57	5.332	9.98	H	Pass



Band :	LTE Band 4	Temperature :	22~25°C
Test Mode :	10MHZ QPSK RB Size 1	Relative Humidity :	45~50%
Test Engineer :	David Yang	Polarization :	Vertical
Remark :	Spurious emissions within 30-10th harmonic were found more than 20dB below limit line.		

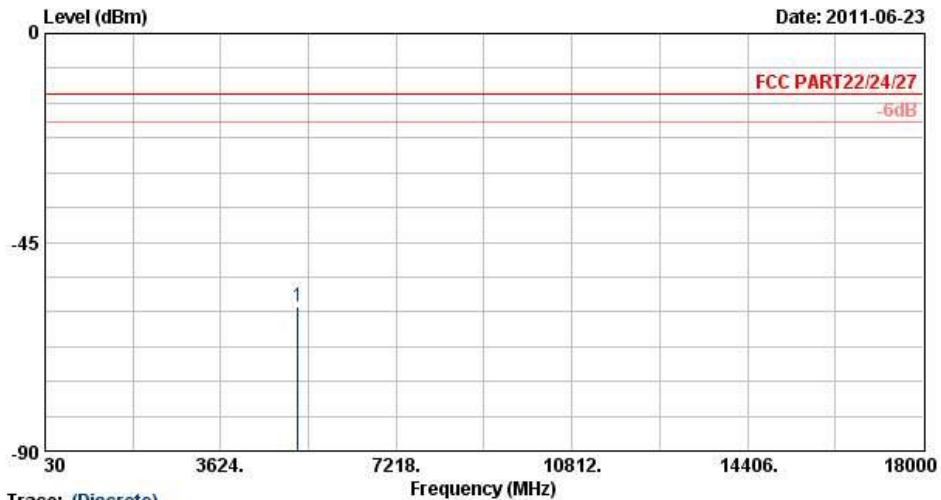

Trace: (Discrete)
 Site : 03CH07-HY
 Condition : FCC PART22/24/27 HF-ETRP(080306) VERTICAL
 Project : FG 132945

Frequency (MHz)	EIRP (dBm)	Limit (dBm)	Over Limit (dB)	SPA Reading (dBm)	S.G. Power (dBm)	TX Cable loss (dB)	TX Antenna Gain (dBi)	Polarization (H/V)	Result
5197	-58.99	-13	-45.99	-78.05	-61.48	5.332	9.98	V	Pass



Band :	LTE Band 4	Temperature :	22~25°C
Test Mode :	10MHZ 16QAM RB Size 1	Relative Humidity :	45~50%
Test Engineer :	David Yang	Polarization :	Horizontal
Remark :	Spurious emissions within 30-10th harmonic were found more than 20dB below limit line.		

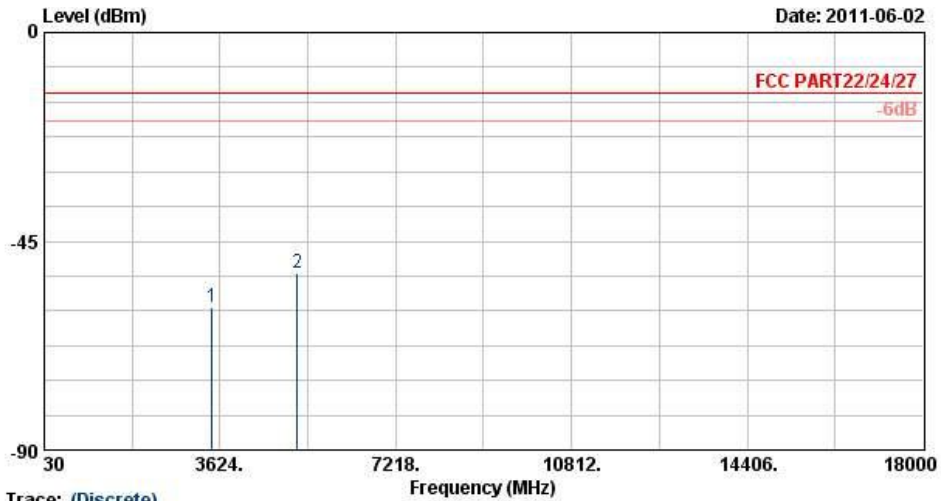

Trace: (Discrete)
 Site : 03CH07-HY
 Condition : FCC PART22/24/27 HF-ETRP(060306) HORIZONTAL
 Project : FG 132945

Frequency (MHz)	EIRP (dBm)	Limit (dBm)	Over Limit (dB)	SPA Reading (dBm)	S.G. Power (dBm)	TX Cable loss (dB)	TX Antenna Gain (dBi)	Polarization (H/V)	Result
3465	-59.19	-13	-46.19	-74.82	-60.87	4.48	8.31	H	Pass
5197	-51.74	-13	-38.74	-71.05	-54.23	5.332	9.98	H	Pass



Band :	LTE Band 4	Temperature :	22~25°C
Test Mode :	10MHZ 16QAM RB Size 1	Relative Humidity :	45~50%
Test Engineer :	David Yang	Polarization :	Vertical
Remark :	Spurious emissions within 30-10th harmonic were found more than 20dB below limit line.		

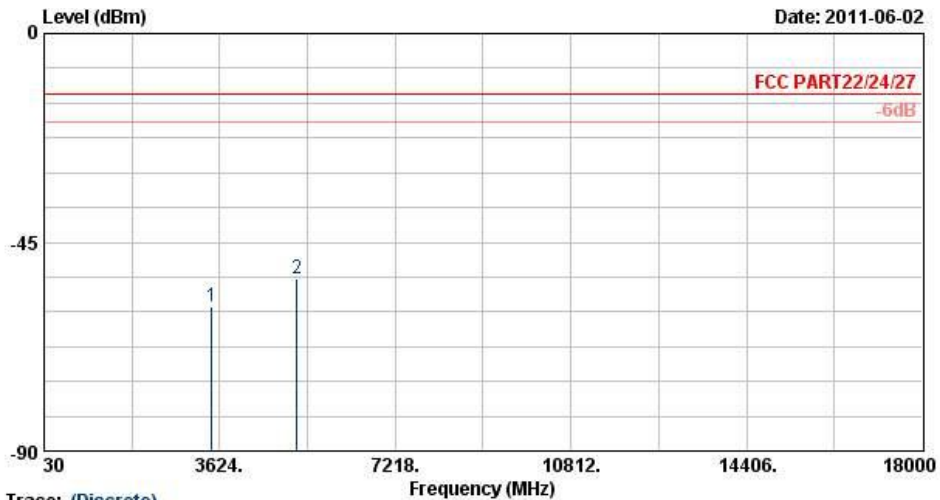

Trace: (Discrete)
 Site : 03CH07-HY
 Condition : FCC PART22/24/27 HF-ETRP(080306) VERTICAL
 Project : FG 132945

Frequency (MHz)	EIRP (dBm)	Limit (dBm)	Over Limit (dB)	SPA Reading (dBm)	S.G. Power (dBm)	TX Cable loss (dB)	TX Antenna Gain (dBi)	Polarization (H/V)	Result
3465	-59.04	-13	-46.04	-75.46	-60.72	4.48	8.31	V	Pass
5197	-52.80	-13	-39.80	-72.2	-55.29	5.332	9.98	V	Pass



Band :	LTE Band 17	Temperature :	22~25°C
Test Mode :	5MHZ QPSK RB Size 1	Relative Humidity :	45~50%
Test Engineer :	David Yang	Polarization :	Horizontal
Remark :	Spurious emissions within 30-10th harmonic were found more than 20dB below limit line.		

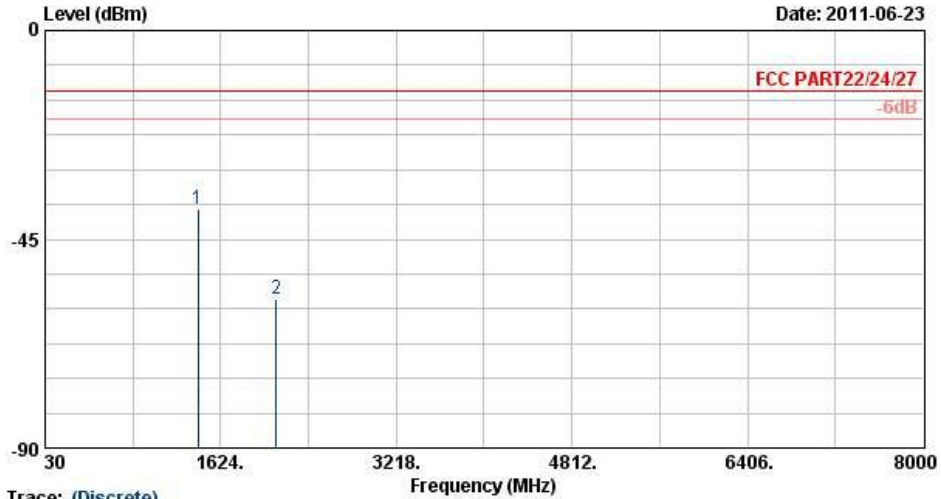

Trace: (Discrete)
 Site : D3CH07-HY
 Condition : FCC PART22/24/27 HF-ETRP(060306) HORIZONTAL
 Project : FG 132945

Frequency (MHz)	EIRP (dBm)	Limit (dBm)	Over Limit (dB)	SPA Reading (dBm)	S.G. Power (dBm)	TX Cable loss (dB)	TX Antenna Gain (dBi)	Polarization (H/V)	Result
1420	-38.59	-13	-25.59	-47.74	-40.52	1.53	5.61	H	Pass
2130	-57.79	-13	-44.79	-68.48	-59.81	1.85	6.02	H	Pass



Band :	LTE Band 17	Temperature :	22~25°C
Test Mode :	5MHZ QPSK RB Size 1	Relative Humidity :	45~50%
Test Engineer :	David Yang	Polarization :	Vertical
Remark :	Spurious emissions within 30-10th harmonic were found more than 20dB below limit line.		

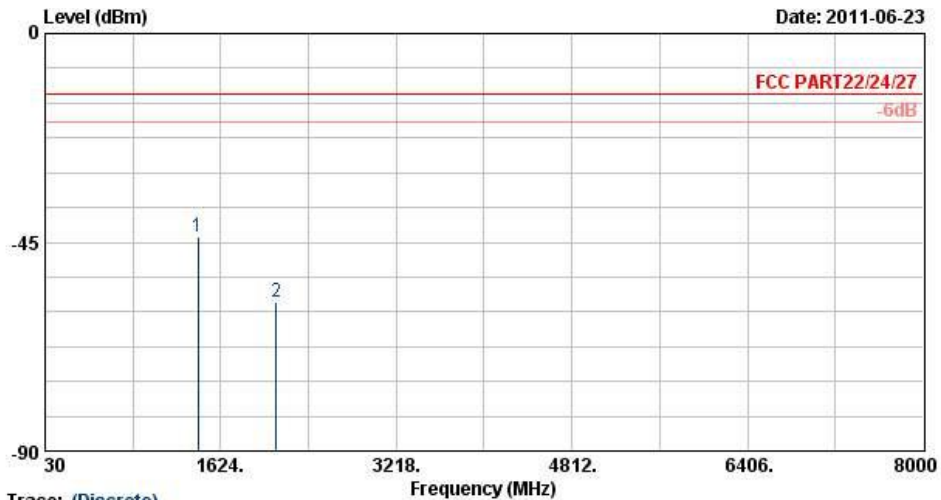

Trace: (Discrete)
 Site : 03CH07-HY
 Condition : FCC PART22/24/27 HF-ETRP(080306) VERTICAL
 Project : FG 132945

Frequency (MHz)	EIRP (dBm)	Limit (dBm)	Over Limit (dB)	SPA Reading (dBm)	S.G. Power (dBm)	TX Cable loss (dB)	TX Antenna Gain (dBi)	Polarization (H/V)	Result
1420	-43.74	-13	-30.74	-54.39	-45.67	1.53	5.61	V	Pass
2130	-57.96	-13	-44.96	-72.37	-59.88	1.98	6.05	V	Pass



Band :	LTE Band 17	Temperature :	22~25°C
Test Mode :	5MHZ 16QAM RB Size 1	Relative Humidity :	45~50%
Test Engineer :	David Yang	Polarization :	Horizontal
Remark :	Spurious emissions within 30-10th harmonic were found more than 20dB below limit line.		

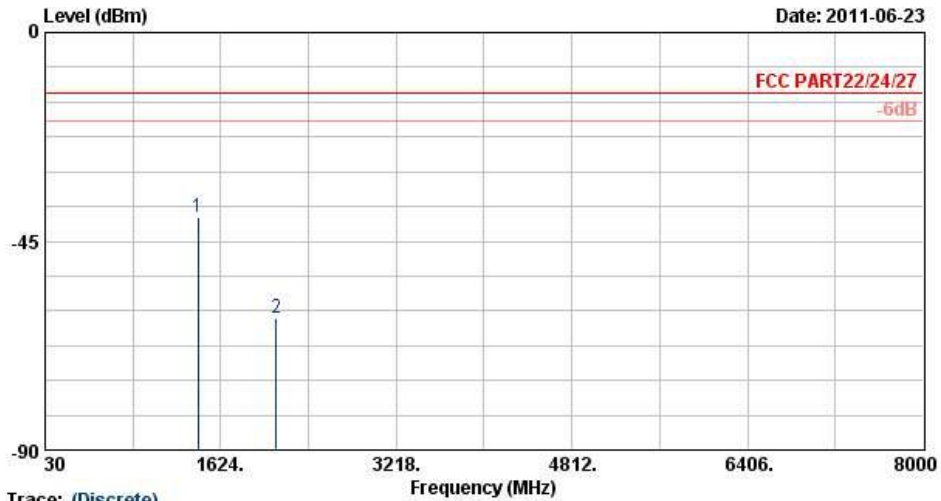

Trace: (Discrete)
 Site : D3CH07-HY
 Condition : FCC PART22/24/27 HF-ETRP(060306) HORIZONTAL
 Project : FG 132945

Frequency (MHz)	EIRP (dBm)	Limit (dBm)	Over Limit (dB)	SPA Reading (dBm)	S.G. Power (dBm)	TX Cable loss (dB)	TX Antenna Gain (dBi)	Polarization (H/V)	Result
1420	-39.83	-13	-26.83	-48.45	-41.76	1.53	5.61	H	Pass
2130	-61.40	-13	-48.40	-74.12	-63.42	1.85	6.02	H	Pass



Band :	LTE Band 17	Temperature :	22~25°C
Test Mode :	5MHZ 16QAM RB Size 1	Relative Humidity :	45~50%
Test Engineer :	David Yang	Polarization :	Vertical
Remark :	Spurious emissions within 30-10th harmonic were found more than 20dB below limit line.		

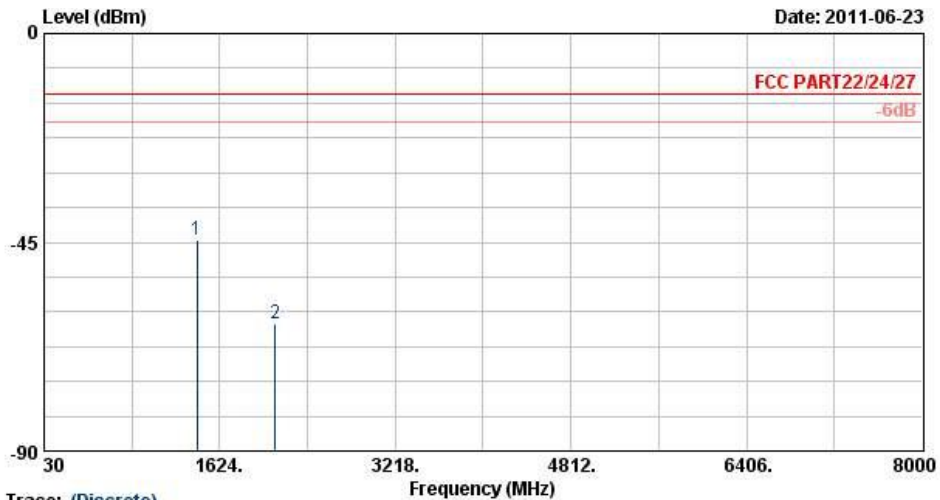

Trace: (Discrete)
 Site : 03CH07-HY
 Condition : FCC PART22/24/27 HF-ETRP(080306) VERTICAL
 Project : FG 132945

Frequency (MHz)	EIRP (dBm)	Limit (dBm)	Over Limit (dB)	SPA Reading (dBm)	S.G. Power (dBm)	TX Cable loss (dB)	TX Antenna Gain (dBi)	Polarization (H/V)	Result
1420	-44.62	-13	-31.62	-56.16	-46.55	1.53	5.61	V	Pass
2130	-62.51	-13	-49.51	-77.27	-64.43	1.98	6.05	V	Pass



Band :	LTE Band 17	Temperature :	22~25°C
Test Mode :	10MHZ QPSK RB Size 1	Relative Humidity :	45~50%
Test Engineer :	David Yang	Polarization :	Horizontal
Remark :	Spurious emissions within 30-10th harmonic were found more than 20dB below limit line.		

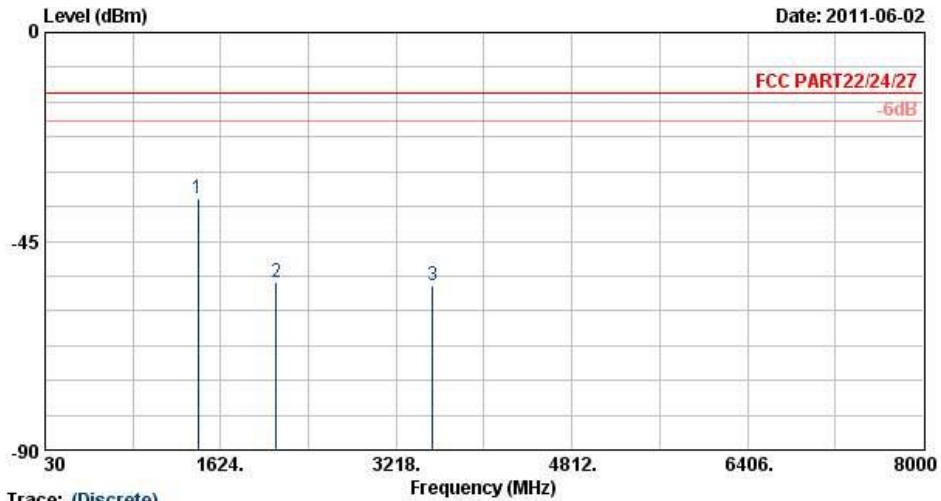

Trace: (Discrete)
 Site : D3CH07-HY
 Condition : FCC PART22/24/27 HF-ETRP(060306) HORIZONTAL
 Project : FG 132945

Frequency (MHz)	EIRP (dBm)	Limit (dBm)	Over Limit (dB)	SPA Reading (dBm)	S.G. Power (dBm)	TX Cable loss (dB)	TX Antenna Gain (dBi)	Polarization (H/V)	Result
1420	-35.69	-13	-22.69	-44.6	-37.62	1.53	5.61	H	Pass
2130	-53.76	-13	-40.76	-64.71	-55.78	1.85	6.02	H	Pass
3550	-54.66	-13	-41.66	-70.47	-58.31	2.46	8.26	H	Pass



Band :	LTE Band 17	Temperature :	22~25°C
Test Mode :	10MHZ QPSK RB Size 1	Relative Humidity :	45~50%
Test Engineer :	David Yang	Polarization :	Vertical
Remark :	Spurious emissions within 30-10th harmonic were found more than 20dB below limit line.		

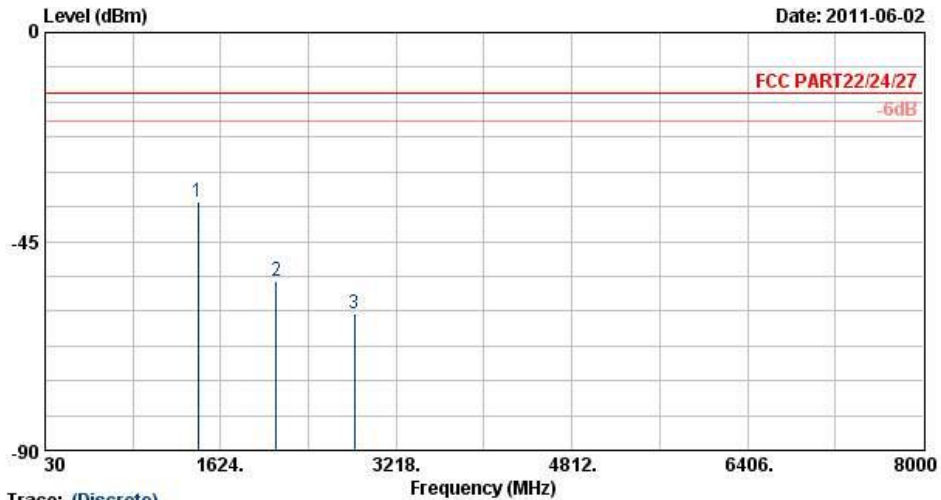

Trace: (Discrete)
 Site : 03CH07-HY
 Condition : FCC PART22/24/27 HF-ETRP(060306) VERTICAL
 Project : FG 132945

Frequency (MHz)	EIRP (dBm)	Limit (dBm)	Over Limit (dB)	SPA Reading (dBm)	S.G. Power (dBm)	TX Cable loss (dB)	TX Antenna Gain (dBi)	Polarization (H/V)	Result
1420	-36.59	-13	-23.59	-48	-38.52	1.53	5.61	V	Pass
2130	-53.44	-13	-40.44	-67.2	-55.36	1.98	6.05	V	Pass
2840	-60.43	-13	-47.43	-76.12	-63.45	2.39	7.56	V	Pass



Band :	LTE Band 17	Temperature :	22~25°C
Test Mode :	10MHZ 16QAM RB Size 1	Relative Humidity :	45~50%
Test Engineer :	David Yang	Polarization :	Horizontal
Remark :	Spurious emissions within 30-10th harmonic were found more than 20dB below limit line.		

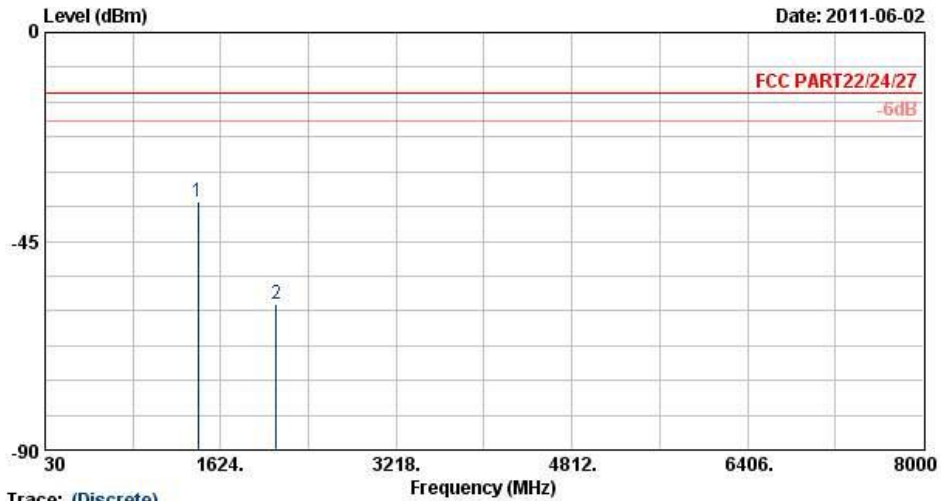

Trace: (Discrete)
 Site : D3CH07-HY
 Condition : FCC PART22/24/27 HF-ETRP(060306) HORIZONTAL
 Project : FG 132945

Frequency (MHz)	EIRP (dBm)	Limit (dBm)	Over Limit (dB)	SPA Reading (dBm)	S.G. Power (dBm)	TX Cable loss (dB)	TX Antenna Gain (dBi)	Polarization (H/V)	Result
1420	-36.33	-13	-23.33	-45.16	-38.26	1.53	5.61	H	Pass
2130	-58.51	-13	-45.51	-70.72	-60.53	1.85	6.02	H	Pass



Band :	LTE Band 17	Temperature :	22~25°C
Test Mode :	10MHZ 16QAM RB Size 1	Relative Humidity :	45~50%
Test Engineer :	David Yang	Polarization :	Vertical
Remark :	Spurious emissions within 30-10th harmonic were found more than 20dB below limit line.		

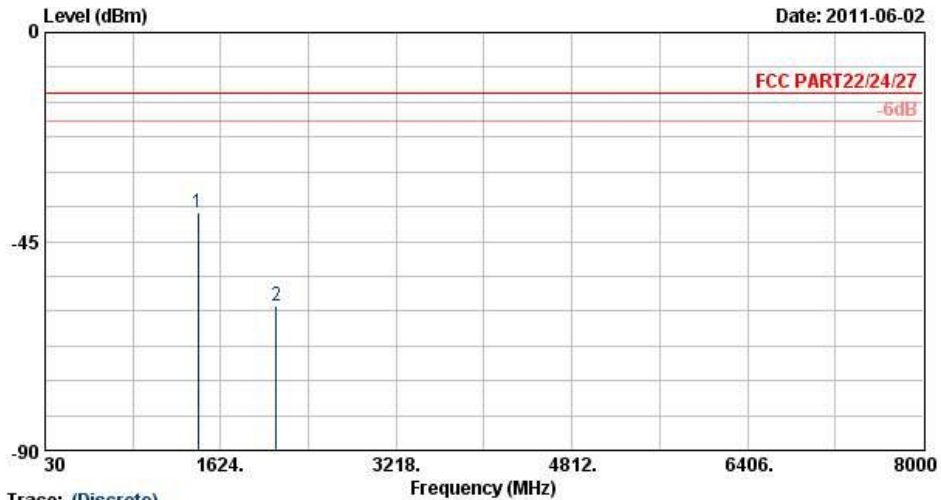

Trace: (Discrete)
 Site : 03CH07-HY
 Condition : FCC PART22/24/27 HF-ETRP(060306) VERTICAL
 Project : FG 132945

Frequency (MHz)	EIRP (dBm)	Limit (dBm)	Over Limit (dB)	SPA Reading (dBm)	S.G. Power (dBm)	TX Cable loss (dB)	TX Antenna Gain (dBi)	Polarization (H/V)	Result
1420	-38.68	-13	-25.68	-50.38	-40.61	1.53	5.61	V	Pass
2130	-58.82	-13	-45.82	-73.27	-60.74	1.98	6.05	V	Pass

3.7 Frequency Stability Measurement

3.7.1 Description of Frequency Stability Measurement

The frequency stability shall be measured by variation of ambient temperature and variation of primary supply voltage to ensure that the fundamental emission stays within the authorized frequency block. The frequency stability of the transmitter shall be maintained within $\pm 0.00025\%$ ($\pm 2.5\text{ppm}$) of the center frequency.

3.7.2 Measuring Instruments

See list of measuring instruments of this test report.

3.7.3 Test Procedures for Temperature Variation

1. The EUT was set up in the thermal chamber and connected with the base station.
2. With power OFF, the temperature was decreased to -30°C and the EUT was stabilized for three hours. Power was applied and the maximum change in frequency was recorded within one minute.
3. With power OFF, the temperature was raised in 10°C step up to 50°C . The EUT was stabilized at each step for at least half an hour. Power was applied and the maximum frequency change was recorded within one minute.
4. If the EUT can not be turned on at -30°C , the testing lowest temperature will be raised in 10°C step until the EUT can be turned on.

3.7.4 Test Procedures for Voltage Variation

1. The EUT was placed in a temperature chamber at $25\pm 5^{\circ}\text{C}$ and connected with the base station.
2. The power supply voltage to the EUT was varied from BEP to 115% of the nominal value measured at the input to the EUT.
3. The variation in frequency was measured for the worst case.

3.7.5 Test Setup

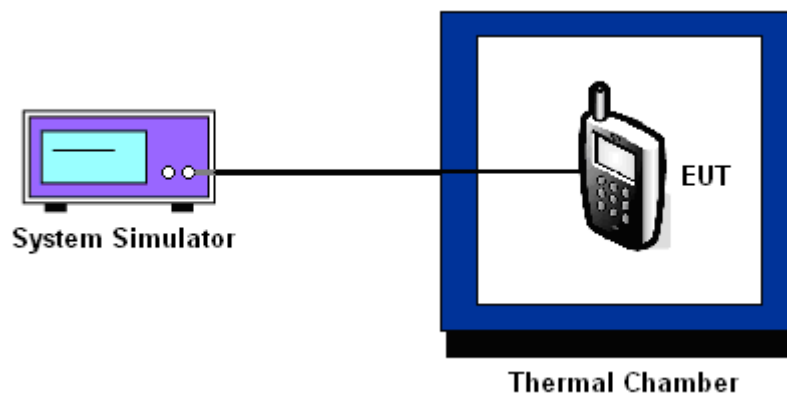



3.7.6 Test Result of Temperature Variation

Band :	LTE Band 4			Limit (ppm) :	2.5
Temperature (°C)	BW 5MHz		BW 10MHz		Result
	Freq. Dev. (Hz)	Deviation (ppm)	Freq. Dev. (Hz)	Deviation (ppm)	
-30	-8.9	-0.005	-9.2	-0.005	PASS
-20	-12.4	-0.007	-11.7	-0.007	
-10	9.3	0.005	-9.9	-0.006	
0	-9.2	-0.005	-10.3	-0.006	
10	-8.7	-0.005	-11.8	-0.007	
20	-8.2	-0.005	-7.3	-0.004	
30	-9.0	-0.005	-7.7	-0.004	
40	-8.3	-0.005	-8.0	-0.005	
50	-7.6	-0.004	-7.5	-0.004	
60	7.3	0.004	-7.0	-0.004	

Band :	LTE Band 17			Limit (ppm) :	2.5
Temperature (°C)	BW 5MHz		BW 10MHz		Result
	Freq. Dev. (Hz)	Deviation (ppm)	Freq. Dev. (Hz)	Deviation (ppm)	
-30	-4.6	-0.006	-4.7	-0.007	PASS
-20	4.0	0.006	-5.1	-0.007	
-10	-4.8	-0.007	-3.9	-0.005	
0	-4.6	-0.006	-4.2	-0.006	
10	4.4	0.006	4.8	0.007	
20	4.9	0.007	4.6	0.006	
30	4.6	0.006	4.3	0.006	
40	4.6	0.006	4.8	0.007	
50	4.0	0.006	5.0	0.007	
60	4.2	0.006	4.1	0.006	



3.7.7 Test Result of Voltage Variation

Band & Channel	Mode	Voltage (Volt)	Freq. Dev. (Hz)	Deviation (ppm)	Limit (ppm)	Result
LTE Band 4	5M	3.9	6.9	0.004	2.5	PASS
		BEP	-9.9	-0.006		
		4.2	14.0	0.008		
	10M	3.9	7.3	0.004		
		BEP	-7.6	-0.004		
		4.2	-9.6	-0.006		
LTE Band 17	5M	3.9	4.5	0.006	2.5	PASS
		BEP	4.1	0.006		
		4.2	3.9	0.005		
	10M	3.9	5.5	0.008		
		BEP	5.4	0.008		
		4.2	4.5	0.006		

Remark:

1. Normal Voltage = 3.9V.
2. Battery End Point (BEP) = 3.6 V.



4 List of Measuring Equipments

Instrument	Manufacturer	Model No.	Serial No.	Characteristics	Calibration Date	Due Date	Remark
Spectrum Analyzer	R&S	FSP30	101329	9kHz~30GHz	May. 03, 2011	May. 02, 2012	Conducted (TH02-HY)
Power Sensor	Agilent	E9327A	US40441548	N/A	Feb. 18, 2011	Feb. 17, 2012	Conducted (TH02-HY)
Bilog Antenna	SCHAFFNER	CBL6111C	2726	30MHz ~ 1GHz	Oct. 31, 2010	Oct. 30, 2011	Radiation (03CH07-HY)
Spectrum Analyzer	R&S	FSP	101067	9KHz ~ 30GHz	Dec. 03, 2010	Dec. 02, 2011	Radiation (03CH07-HY)
Double Ridge Horn Antenna	ESCO	3117	00075962	1GHz ~ 18GHz	Aug. 19, 2010	Aug. 18, 2011	Radiation (03CH07-HY)
SHF-EHF Horn Antenna	SCHWARZBECK	BBHA 9170	BBHA917025 1	15GHz- 40GHz	Oct. 18, 2010	Oct. 17, 2011	Radiation (03CH07-HY)
Pre Amplifier	Agilent	8449B	3008A02362	1GHz~ 26.5GHz	Dec. 06, 2010	Dec. 05, 2011	Radiation (03CH07-HY)
Pre Amplifier	COM-POWER	PA-103A	161241	10-1000MHz.32dB. GAIN	Mar. 29, 2011	Mar. 28, 2012	Radiation (03CH07-HY)
Loop Antenna	R&S	HFH2-Z2	860004/001	9 kHz~30 MHz	Jul. 29, 2010	Jul. 28, 2011	Radiation (03CH07-HY)
LTE Base Station	Anritsu	MT8820C	6200930978	N/A	Dec. 28, 2010	Dec. 27, 2011	Radiation (03CH07-HY)

5 Uncertainty of Evaluation

Uncertainty of Radiated Emission Measurement (30 MHz ~ 1000 MHz)

Contribution	Uncertainty of X_i		$u(X_i)$
	dB	Probability Distribution	
Receiver Reading	0.41	Normal (k=2)	0.21
Antenna Factor Calibration	0.83	Normal (k=2)	0.42
Cable Loss Calibration	0.25	Normal (k=2)	0.13
Pre-Amplifier Gain Calibration	0.27	Normal (k=2)	0.14
RCV/SPA Specification	2.50	Rectangular	0.72
Antenna Factor Interpolation for Frequency	1.00	Rectangular	0.29
Site Imperfection	1.43	Rectangular	0.83
Mismatch	+0.39 / -0.41	U-Shape	0.28
Combined Standard Uncertainty $U_c(y)$	1.27		
Measuring Uncertainty for a Level of Confidence of 95% ($U = 2U_c(y)$)	2.54		

Uncertainty of Radiated Emission Measurement (1 GHz ~ 40 GHz)

Contribution	Uncertainty of X_i		$u(X_i)$	C_i	$C_i * u(X_i)$
	dB	Probability Distribution			
Receiver Reading	± 0.10	Normal (k=2)	0.10	1	0.10
Antenna Factor Calibration	± 1.70	Normal (k=2)	0.85	1	0.85
Cable Loss Calibration	± 0.50	Normal (k=2)	0.25	1	0.25
Receiver Correction	± 2.00	Rectangular	1.15	1	1.15
Antenna Factor Directional	± 1.50	Rectangular	0.87	1	0.87
Site Imperfection	± 2.80	Triangular	1.14	1	1.14
Mismatch Receiver VSWR $\Gamma_1 = 0.197$ Antenna VSWR $\Gamma_2 = 0.194$ Uncertainty = $20\text{Log}(1-\Gamma_1*\Gamma_2)$	+0.34 / -0.35	U-Shape	0.244	1	0.244
Combined Standard Uncertainty $U_c(y)$	2.36				
Measuring Uncertainty for a Level of Confidence of 95% ($U = 2U_c(y)$)	4.72				