



A Test Lab Techno Corp.

Changan Lab : No. 140 -1, Changan Street, Bade City, Taoyuan County, Taiwan R.O.C.
Tel : 886-3-271-0188 / Fax : 886-3-271-0190

HAC EVALUATION REPORT



Test Report No.	: 1008FS18
Applicant	: HTC Corporation
Trade Name	: HTC
Model Number	: PD98120
EUT Type	: Smartphone
FCC ID	: NM8PD98120
Dates of Test	: Aug. 26, 2010 ~ Oct. 12, 2010
Issued Date	: Mar. 11, 2011
Test Environment	: Ambient Temperature : 22 ± 2 °C Relative Humidity : 40 - 70 %
FCC Rule Part(s)	: FCC 47 CFR § 20.19.
HAC Standard	: ANSI C63.19-2007
C63.19 HAC Rated Category	: M3 (RF EMISSIONS)
Test Lab.	: Chang-An Lab

1. The test operations have to be performed with cautious behavior, the test results are as attached.
2. The test results are under chamber environment of A Test Lab Techno Corp. A Test Lab Techno Corp. does not assume responsibility for any conclusions and generalizations drawn from the test results with regard to other specimens or samples.
3. The measurement report has to be written approval of A Test Lab Techno Corp. It may only be reproduced or published in full. This report shall not be reproduced except in full, without the written approval of A Test Lab Techno Corp.

This document may be altered or revised by A Test Lab Techno. Corp. personnel only, and shall be noted

Approved By : Sam Chuang
(Sam Chuang)

Tested By : Alex Wu
(Alex Wu)



Contents

1. Description of Equipment under Test (EUT)	3
2. Introduction	4
3. Test Equipment List.....	5
4. Test Procedure	6
5. System Check.....	7
5.1 System check parameters.....	7
5.2 Validation Procedure	7
5.3 Illustrative dipole calculated and measured values.....	8
5.4 Validation Results	9
6. Probe Modulation Factor.....	10
7. HAC Testing with RF Transmitters	13
8. Test Results.....	14
8.1 HAC E-Field measurement results.....	14
8.2 HAC H-Field measurement results.....	16
8.3 Description of the Device under Test (DUT).....	18
Appendix A - Details of WD signal.....	19
Appendix B - Validation	21
Appendix C - HAC distribution plots for E-Field and H-Field.....	29
Appendix D - Calibration.....	57
Appendix E - Uncertainty.....	95



1. Description of Equipment under Test (EUT)

Applicant	:	HTC Corporation		
Applicant Address	:	No. 23, Xinghua Rd., Taoyuan City, Taoyuan County 330, Taiwan		
Manufacturer	:	HTC Corporation		
Manufacturer Address	:	No. 23, Xinghua Rd., Taoyuan City, Taoyuan County 330, Taiwan		
EUT Type	:	Smartphone		
Trade Name	:	HTC		
Model Number	:	PD98120		
FCC ID	:	NM8PD98120		
IMIE No	:	354455040010165		
RF Output Power	:	0.258 W	(24.12 dBm)	GSM 850
		0.121 W	(20.81 dBm)	PCS 1900
		0.269 W	(24.30 dBm)	WCDMA Band II
		0.254 W	(24.05 dBm)	WCDMA Band V
Tx Frequency	:	824.2 - 848.8	MHz (GSM 850)	
		1850.2 - 1909.8	MHz (PCS 1900)	
		1852.6 - 1907.4	MHz (WCDMA Band II)	
		826.6 - 846.4	MHz (WCDMA Band V)	
Antenna Type	:	PIFA Type		
Test Device	:	Production Unit		
Device Category	:	Portable		

This wireless portable device has performed Hearing Aid Compatibility (HAC) measurements for the portable cellular phone. The measurements were performed to ensure compliance to the ANSI C63.19-2007 standards.



2. Introduction

The A Test Lab Techno Corp. has performed measurements of the maximum potential exposure to the user of **HTC Corporation Trade Name: HTC Model(s) : PD98120**. The test procedures, as described in ANSI C63.19-2007 standard were employed. A description of the product and operating configuration, detailed summary of the test results, methodology and procedures used in the equipment are included within this test report.

Difference Description of EUT

The model (HTC_PD98120) have different components source. The other circuit designed is the same. Sample 1st & Sample 2nd is use difference components (list below).

Component Name	Component Model No.			
	Sample 1 st		Sample 2 nd	
Camera	#1	Lite-On Technology Corporation Liteon, 10P1BA801	#2	Foxconn Electronics Inc. Foxconn, CMHT-8AA01D
LCM	#1	Sharp Corporation Sharp, LQ043Y1DX02	#2	AU Optronics Corp. AUO, H430VL02 V4
GSM Power Amplifier	#1	TriQuint Semiconductor TriQuint, TQM7M5013	#2	Avago Technologies Avago, ACPM-7868

- ※ We assume the second source of amplifier, May influence the RF emission. Therefore it was tested with worse case of main source.
- ※ According to our experience, it will not influence RF Emission to change Camera and LCM .When it is the same of the specification.



3. Test Equipment List

Manufacturer	Name of Equipment	Type/Model	Serial Number	Calibration	
				Last Cal.	Due Date
SPEAG	Dosimetric E-Filed Probe	ER3DV6	2302	Jun. 15, 2010	Jun. 15, 2011
SPEAG	Dosimetric H-Filed Probe	H3DV6	6187	Jun. 15, 2010	Jun. 15, 2011
SPEAG	835 MHz System Validation Kit	CD835V3	1017	Jul. 13, 2010	Jul. 13, 2011
SPEAG	1880 MHz System Validation Kit	CD1880V3	1036	Jul. 13, 2010	Jul. 13, 2011
SPEAG	Data Acquisition Electronics	DAE4	779	Jan. 21, 2010	Jan. 21, 2011
SPEAG	Device Holder	N/A	N/A	NCR	
SPEAG	Phantom	SAM V4.0	TP-1150	NCR	
SPEAG	Robot	Staubli TX90XL	F07/564ZA1/C/01	NCR	
SPEAG	Software	DASY5 V5.0 Build 91	N/A	NCR	
SPEAG	Software	SEMCAD X V12.4 Build 52	N/A	NCR	
SPEAG	Measurement Server	SE UMS 011 AA	1025	NCR	
Agilent	Wireless Communication Test Set	CMU200	109369	Jul. 29, 2009	Jul. 29, 2011
Agilent	Spectrum Analyzer(ESA-L)	E4408B	MY45107753	Jun. 23, 2009	Jun. 23, 2011
R&S	Spectrum Analyzer(FSL)	FSL6	100410	Mar. 25, 2009	Mar. 25, 2011
Agilent	Power Meter	E4418B	GB40206143	Jun. 19, 20010	Jun. 19, 2011
Agilent	Signal Generator	E8257D	MY44320425	NCR	
R&S	Power Sensor	8481H	3318A20779	Jun. 19, 20010	Jun. 19, 2011
Agilent	Dual Directional Coupler	778D	50334	NCR	
Mini-Circuits	Power Amplifier	ZVE-8G	D042005 671800514	NCR	
Mini-Circuits	Power Amplifier	ZHL-42W-SMA	D111103#5	NCR	

Table 1. Test Equipment List

4. Test Procedure

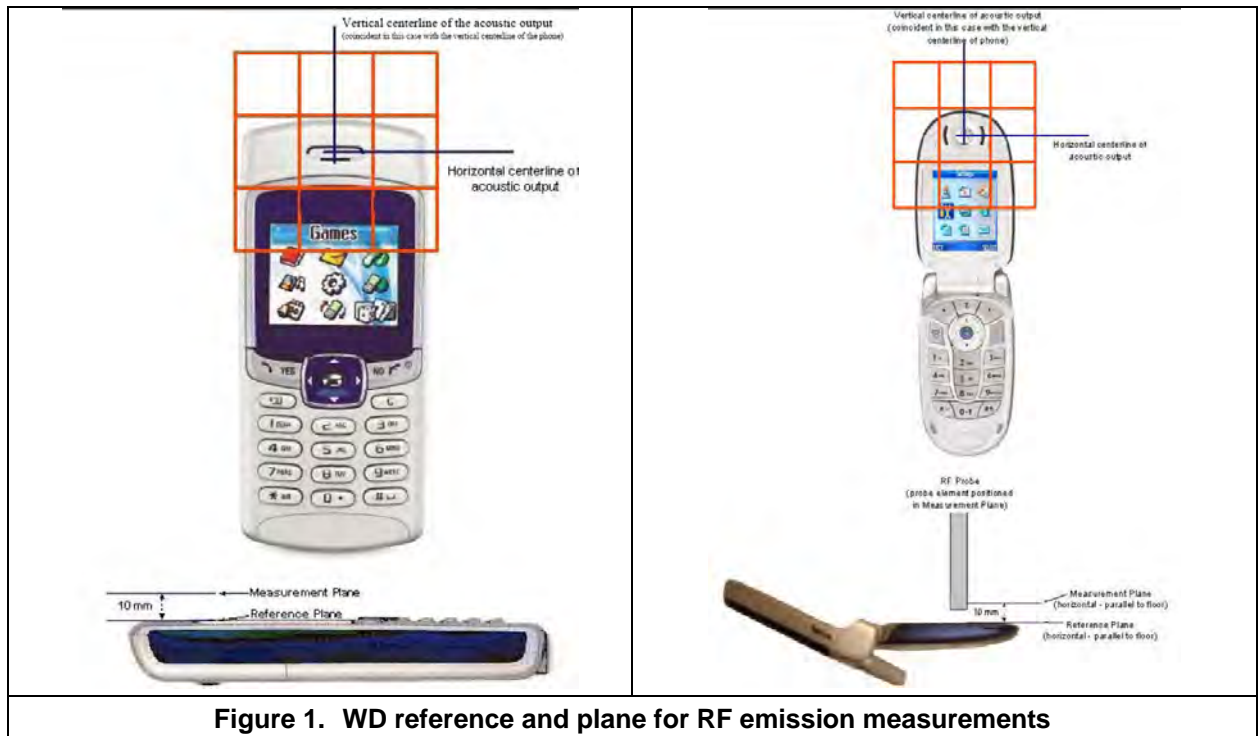

The following illustrate a typical RF emissions test scan over a wireless communications device:

1. Proper operation of the field probe, probe measurement system, other instrumentation, and the positioning system was confirmed.
2. WD is positioned in its intended test position, acoustic output point of the device perpendicular to the field probe.
3. The WD operation for maximum rated RF output power was configured and confirmed with the base station simulator, at the test channel and other normal operating parameters as intended for the test. The battery was ensured to be fully charged before each test.
4. The center sub-grid was centered over the center of the acoustic output (also audio band magnetic output, if applicable). The WD audio output was positioned tangent (as physically possible) to the measurement plane.
5. A surface calibration was performed before each setup change to ensure repeatable spacing and proper maintenance of the measurement plane using the HAC Phantom.
6. The measurement system measured the field strength at the reference location.
7. Measurements at 2mm or 5mm increments in the 5 x 5 cm region were performed at a distance 15 mm from the center point of the probe measurement element to the WD. A 360o rotation about the azimuth axis at the maximum interpolated position was measured. For the worst-case condition, the peak reading from this rotation was used in re-evaluating the HAC category.
8. The system performed a drift evaluation by measuring the field at the reference location.
9. Steps 1-8 were done for both the E and H-Field measurements.

5. System Check

5.1 System check parameters

The input signal was an un-modulated continuous wave. The following points were taken into consideration in performing this check:

- Average Input Power $P = 100\text{mW RMS}$ (20dBm RMS) after adjustment for return loss.
- The test fixture must meet the 2 wavelength separation criterion.
- The proper measurement of the 1 cm probe to dipole separation, which is measured from top surface of the dipole to the calibration reference point of the sensor, defined by the probe manufacturer is shown in the following diagram:

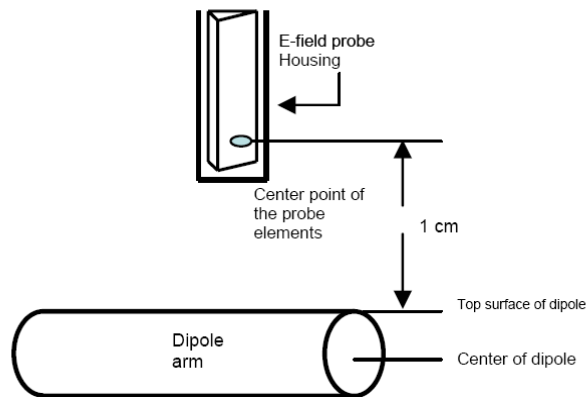

5.2 Validation Procedure

Place a dipole antenna meeting the requirements given in ANSI-PC63.19 in the position normally occupied by the WD. The dipole antenna serves as a known source for an electrical and magnetic output. Position the E-field and H-field probes so that:

- the probes and their cables are parallel to the coaxial feed of the dipole antenna
- the probe cables and the coaxial feed of the dipole antenna approach the measurement area from opposite directions; and
- the probes are 10 mm from the surface of the dipole elements.

Scan the length of the dipole with both E-field and H-field probes and record the maximum values for each. Compare the readings to expected values.

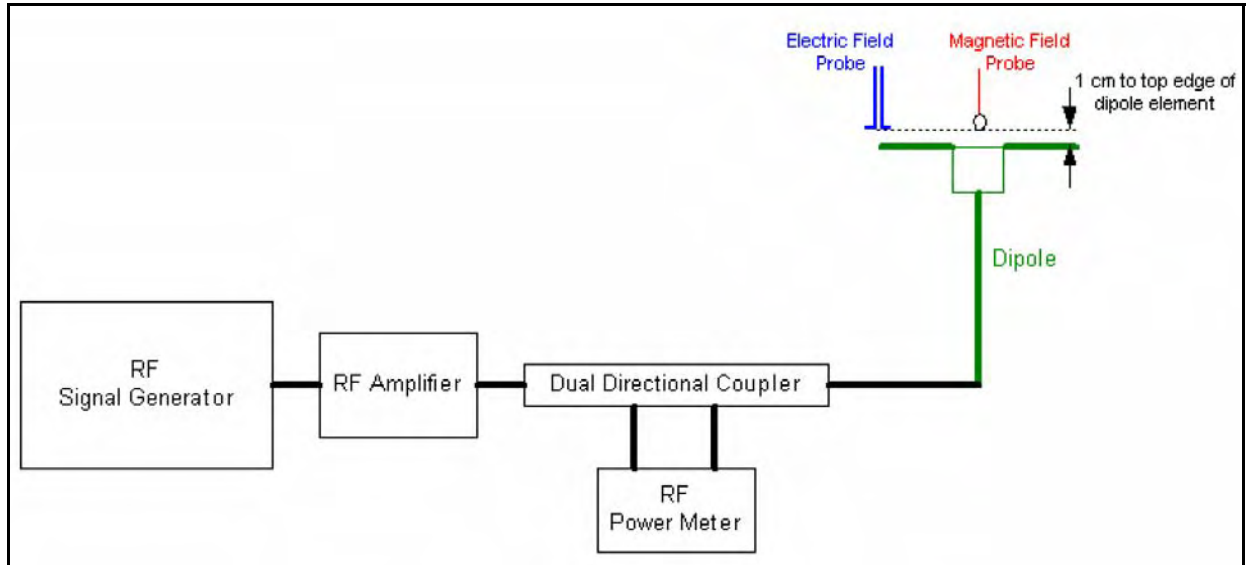

Figure 2. WD dipole calibration procedure

5.3 Illustrative dipole calculated and measured values

Baseband frequencies (MHz)	Frequency (MHz)	E-field calculated values (V/m)	E-field measured values (V/m)	E-field delta (calculated to measured) (V/m) & %	H-field calculated values (A/m)	H-field measured values (A/m)	H-field delta (calculated to measured) (A/m) & %
790–850	835	187			0.476		
806–821	813.5	190			0.481		
896–901	898.5	185			0.477		
1880–2000	1880	149			0.456		
		224.6–236.4			0.5139–0.5226		
		214.9–232.2			0.4954–0.5164		
		213.2–220.9			0.5032–0.5005		
		153.6–149.3			0.4478–0.4035		

NOTE 1— Numeric modeling results will vary based on several factors, including the size of the computational area, boundary conditions selected, grid resolution, accuracy of models for material properties, and other factors. Further, the results obtained by numeric modeling will vary from measured results based on many additional factors, including the degree to which the probe perturbs the field, the degree to which the probe averages the field strength over its dimensions, the linearity of the probe, the differences between the physical dipole and its modeled representation, and many other factors. Numeric computations provided to the committee showed significant variability between different results. Accordingly the values provided should be used judiciously and not interpreted to be absolutely correct. The calculated values provided for dipoles were developed using theoretical numerical computation.

NOTE 2— Delta % = $100 \times (\text{measured peak} - \text{calculated}) / \text{calculated}$. Values within $\pm 25\%$ are acceptable, of which 12% is deviation and 13% is measurement uncertainty. Values independently validated for the dipole actually used in the measurements should be used, when available.



5.4 Validation Results

Dipole	Freq. (MHz)	Protocol	Input Power (mW)	Target for Dipole (V/m)	E-Field Results (V/m)	Deviation	Date
SN:1017	835	CW	100	168.6	167.2	-0.8%	Aug. 26, 2010
SN:1017	835	CW	100	168.6	170.6	1.2%	Oct. 12, 2010
SN:1036	1880	CW	100	139.2	137.1	-1.5%	Aug. 26, 2010
SN:1036	1880	CW	100	139.2	148.2	6.5%	Oct. 12, 2010

Table 2. Dipole E-Field Measurement Summary

Dipole	Freq. (MHz)	Protocol	Input Power (mW)	Target for Dipole (A/m)	H-Field Results (A/m)	Deviation	Date
SN:1017	835	CW	100	0.457	0.459	-1.9%	Aug. 26, 2010
SN:1017	835	CW	100	0.457	0.465	1.8%	Oct. 12, 2010
SN:1036	1880	CW	100	0.468	0.459	0.4%	Aug. 26, 2010
SN:1036	1880	CW	100	0.468	0.465	-0.6%	Oct. 12, 2010

Table 3. Dipole H-Field Measurement Summary

6. Probe Modulation Factor

After every probe calibration, the response of the probe to each applicable modulated signal (CDMA, GSM, WCDMA (UMTS), etc) must be assessed at both 835 MHz, 1880 MHz. The response of the probe system to a CW field at the frequency(s) of interest is compared to its response to a modulated signal with equal peak amplitude. For each PMF assessment, a Signal Generator was used to replace the original CW signal with the desired modulated signal. The PMF results are shown in Table 4. RF Field Probe Modulation Response was measured with the field probe and associated measurement equipment. The PMF was measured per ANSI C63.19-2007 using a signal generator as follows:

1. Illuminate a dipole with a CW signal at the intended measured frequency.
2. Fix the probe at a set location relative to the dipole; typically located at the field reference point.
3. Record the reading of the probe measurement system of the CW signal.
4. Substitute a modulated signal of the same amplitude, using the same modulation as that used by the intended WD for the CW signal.
5. Record the reading of the probe measurement system of the modulated signal.
6. The ratio of the CW to modulated signal reading is the probe modulation factor.
7. Spectrum analyzer settings:
 - Center Frequency: nominal center frequency of channel
 - Span: zero
 - Resolution bandwidth \geq emission bandwidth
 - Video bandwidth \geq 20 kHz.
 - Detection: RMS detection.
 - Trigger: Video or IF trigger, adjusted to give a stable display of the transmission.
 - Sweep rate: Set to show a complete transmission cycle.
 - Line max hold may be used temporarily to ease the peak reading.
8. Calculate the Probe Modulation Factor as the ratio between the CW multimeter field reading and the reading for the applicable modulation. I.e., $PMF = \frac{E_{CW}}{E_{mod}}$ and similar for H.

gfortheapplicablemodulation.I.e., $PMF = \frac{E_{CW}}{E_{mod}}$ and similar for H.

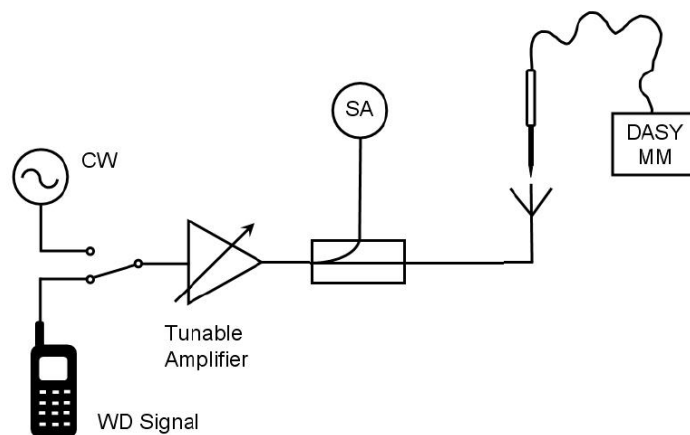

Figure 3. Probe Modulation Factor Measurement Diagram



Formula between PMF and test results

1. HAC test of device and determine the maximum value (M) of grids.
2. Determine the value (P) of PMF according to (M).
3. Find the maximum value (F) from the other data.

$$R = P * F$$

Example:

E-Field Maximum value (M) = 52, Maximum value (F) = 51.8, PMF (P) = 2.82

R = 51.8 * 2.82 = 146.076 V/m

Frequency (MHz)	Protocol	E-Field Probe SN:2302		H-Field Probe SN:6187	
		E-Field (V/m)	E-Field Modulation Factor	H-Field (A/m)	H-Field Modulation Factor
835.0	GSM	< 47	2.53	< 0.14	1.81
		47 - 63	2.54	0.14 - 0.19	2.12
		63 - 84	2.54	0.19 - 0.25	2.37
		84 - 112	2.55	0.25 - 0.34	2.57
		112 - 150	2.56	0.34 - 0.45	2.68
		150 - 200	2.56	0.45 - 0.60	2.71
		200 - 266	2.57	0.60 - 0.80	2.64
		266 - 355	2.57	0.80 - 1.07	2.49
		355 - 473	2.58	1.07 - 1.43	2.26
		473 - 631	2.58	1.43 - 1.91	1.98
		631 - 841	2.59	1.91 - 2.54	1.67
841 - 1122	2.60	2.54 - 3.39	1.36		
1880.0	GSM	< 47	2.53	< 0.14	2.63
		47 - 63	2.52	0.14 - 0.19	2.59
		63 - 84	2.51	0.19 - 0.25	2.54
		84 - 112	2.50	0.25 - 0.34	2.44
		112 - 150	2.49	0.34 - 0.45	2.32
		150 - 200	2.48	0.45 - 0.60	2.18
		200 - 266	2.47	0.60 - 0.80	2.02
		266 - 355	2.46	0.80 - 1.07	1.92
		355 - 473	2.45	1.07 - 1.43	1.73
		473 - 631	2.44	1.43 - 1.91	1.54
		631 - 841	2.43	1.91 - 2.54	1.36
841 - 1122	2.42	2.54 - 3.39	1.17		



Frequency (MHz)	Protocol	E-Field Probe SN:2302		H-Field Probe SN:6187	
		E-Field (V/m)	E-Field Modulation Factor	H-Field (A/m)	H-Field Modulation Factor
835.0	WCDMA(UMTS)	< 47	1.07	< 0.14	0.86
		47 - 63	1.04	0.14 - 0.19	0.86
		63 - 84	1.01	0.19 - 0.25	0.85
		84 - 112	0.98	0.25 - 0.34	0.83
		112 - 150	0.95	0.34 - 0.45	0.81
		150 - 200	0.92	0.45 - 0.60	0.78
		200- 266	0.89	0.60 - 0.80	0.75
		266 - 355	0.87	0.80 - 1.07	0.72
		355 - 473	0.84	1.07 - 1.43	0.68
		473 - 631	0.82	1.43 - 1.91	0.64
		631 - 841	0.79	1.91 - 2.54	0.61
841 - 1122	0.77	2.54 - 3.39	0.56		
1880.0	WCDMA(UMTS)	< 47	0.90	< 0.14	0.81
		47 - 63	0.89	0.14 - 0.19	0.76
		63 - 84	0.89	0.19 - 0.25	0.71
		84 - 112	0.89	0.25 - 0.34	0.65
		112 - 150	0.89	0.34 - 0.45	0.59
		150 - 200	0.89	0.45 - 0.60	0.52
		200- 266	0.89	0.60 - 0.80	0.46
		266 - 355	0.89	0.80 - 1.07	0.39
		355 - 473	0.89	1.07 - 1.43	0.33
		473 - 631	0.88	1.43 - 1.91	0.28
		631 - 841	0.88	1.91 - 2.54	0.23
841 - 1122	0.88	2.54 - 3.39	0.19		

Table 4. PMF Measurement Summary

Note: PMF measurements were verified at WD's power as an input to the dipole.



7. HAC Testing with RF Transmitters

The phone was tested in all normal configurations for the ear use. A DUT is mounted in the device holder equivalent as for classic dosimetric measurements. The acoustic output of the DUT shall coincide with the center point of the area formed by the dielectric wire and the middle bar of the arch's top frame. The DUT shall be moved vertically upwards until it touches the frame. The fine adjustment is possible by sliding the complete DUT holder on the yellow base plate of the Test Arch phantom. These test configurations are tested at the high, middle and low frequency channels of each applicable operating mode; for example, GSM, WCDMA (UMTS), CDMA and TDMA.

CDMA Devices setup for HAC Measurement.

The signal was setup by creating and maintaining an over the coaxial connection between the DUT and an R&S CMU200 Wireless Communications Test Set. The CDMA radio is available on CDMA 2000(1X) and IS-95. The test equipment was configured to use "all up bits" for RC1 / SO2 on J-STD-008 for CDMA 1900 and TSB-84 for CDMA 800 MHz. The 5cm x 5cm area measurement grid is centered on the acoustic output of the device. The Test Arch provided by SPEAG is used to position the DUT. The WD reference plane is parallel to the device and contains the highest point on its contour in the area of the phone that normally rests against the user's ear. The measurement plane contains the nearest point on the probe sensor(s) relative to the WD. The pictures of the setup are included in 7.3.

WCDMA Devices setup for HAC Measurement.

The following procedures are applicable to WCDMA handsets operating under 3GPP Release 99 and Release 5. The default test configuration is to measure HAC with an established radio link between the DUT and a communication test set using a 12.2 kbps RMC (reference measurement channel) configured in Test Loop Mode 1. HAC is selectively confirmed for other physical channel configurations (DPCCH & DPDCH_n) according to output power, exposure conditions and device operating capabilities. Both uplink and downlink should be configured with the same RMC or AMR, when required. Maximum output power is verified according to 3GPP TS 34.121 and HAC must be measured according to these maximum output conditions.



8. Test Results

8.1 HAC E-Field measurement results

Band	Rating	E-Field
GSM 850	M3	149.6 to 266.1 V/m
	M4	< 149.6 V/m
PCS 1900	M3	47.3 to 84.1 V/m
	M4	< 47.3 V/m
WCDMA Band V	M3	199.5 to 354.8
	M4	< 199.5
WCDMA Band II	M3	63.1 to 112.2
	M4	< 63.1

Table 5. Emissions Limits

Band	Channel	Conducted Power (dBm)	Measured PMF	Drift (dB)	Excluded Cells	Peak Field (V/m)	Rating	Note
GSM 850	128	24.12	2.56	0.046	6.8.9	132.8	M4	1 st
	190	24.11	2.56	-0.00829	6.8.9	134.3	M4	1 st
	251	24.01	2.56	-0.089	6.8.9	148.5	M4	1 st
	251	24.01	2.56	-0.00298	6.8.9	153.6	M3	2 nd
PCS 1900	512	19.61	2.50	-0.103	6.8.9	59.2	M3	1 st
	661	20.51	2.50	0.074	6.8.9	67.7	M3	1 st
	661	20.51	2.50	0.088	6.8.9	72.9	M3	2 nd
	810	20.81	2.50	0.046	6.8.9	64.2	M3	1 st
WCDMA Band II	9262	24.01	0.90	0.019	6.8.9	37.1	M4	1 st
	9400	24.05	0.90	0.108	6.8.9	38.3	M4	1 st
	9537	24.30	0.90	0.017	6.8.9	35.7	M4	1 st
WCDMA Band V	4132	23.97	1.04	0.136	6.8.9	58.6	M4	1 st
	4180	24.05	1.01	0.164	6.8.9	63.5	M4	1 st
	4233	23.91	1.01	-0.00697	6.8.9	66.0	M4	1 st

Note: HAC E-Field measurement results for the portable cellular telephone at highest possible output power.



Turn on Wi-Fi and Bluetooth Function

Band	Channel	Wireless Mode	Peak Field (V/m)
GSM 850	251	-----	148.5
		Wi-Fi	148.1
		Bluetooth	148.3
PCS 1900	661	-----	67.7
		Wi-Fi	67.3
		Bluetooth	67.4
WCDMA Band II	9400	-----	38.3
		Wi-Fi	38.1
		Bluetooth	38.2
WCDMA Band V	4233	-----	66.0
		Wi-Fi	65.8
		Bluetooth	65.5



8.2 HAC H-Field measurement results

Band	Rating	H-Field
GSM 850	M3	0.45 to 0.80 A/m
	M4	< 0.45 A/m
PCS 1900	M3	0.14 to 0.25 A/m
	M4	<0.14 A/m
WCDMA Band V	M3	0.60 to 1.07
	M4	< 0.60
WCDMA Band II	M3	0.19 to 0.34
	M4	< 0.19

Table 6. Emissions Limits

Band	Channel	Conducted Power (dBm)	Measured PMF	Drift (dB)	Excluded Cells	Peak Field (A/m)	Rating	Note
GSM 850	128	24.12	2.37	0.071	1.4.7	0.173	M4	1 st
	190	24.11	2.57	0.080	1.4.7	0.189	M4	1 st
	251	24.01	2.57	0.010	1.4.7	0.215	M4	1 st
	251	24.01	2.68	-0.125	1.4.7	0.242	M4	2 nd
PCS 1900	512	19.61	2.54	0.017	1.2.3	0.192	M3	1 st
	661	20.51	2.54	0.00979	1.2.3	0.201	M3	1 st
	661	20.51	2.44	-0.00784	1.2.3	0.229	M3	2 nd
	810	20.81	2.54	-0.011	1.2.3	0.192	M3	1 st
WCDMA Band II	9262	24.01	0.81	-0.070	1.2.3	0.101	M4	1 st
	9400	24.05	0.81	-0.0285	1.2.3	0.099	M4	1 st
	9538	24.30	0.81	0.128	1.2.3	0.092	M4	1 st
WCDMA Band V	4132	23.97	0.86	-0.066	1.4.7	0.070	M4	1 st
	4180	24.05	0.86	0.149	1.4.7	0.078	M4	1 st
	4233	23.91	0.86	0.031	1.4.7	0.083	M4	1 st

Note: HAC H-Field measurement results for the portable cellular telephone at highest possible output power.



Turn on Wi-Fi and Bluetooth Function

Band	Channel	Wireless Mode	Peak Field (V/m)
GSM 850	251	-----	0.215
		Wi-Fi	0.211
		Bluetooth	0.212
PCS 1900	661	-----	0.201
		Wi-Fi	0.198
		Bluetooth	0.196
WCDMA Band II	9262	-----	0.101
		Wi-Fi	0.097
		Bluetooth	0.096
WCDMA Band V	4233	-----	0.083
		Wi-Fi	0.080
		Bluetooth	0.081



8.3 Description of the Device under Test (DUT)

Modes and Bands of Operation	GSM 850	PCS 1900	WCDMA Band V	WCDMA Band II
Modulation Mode	GMSK	GMSK	QPSK	QPSK
Duty Cycle	1/8.3	1/8.3	1/1	1/1
Transmitter Frequency Range (MHz)	824.2 - 848.8	1850.2 - 1909.8	826.6 - 846.4	1852.6 - 1907.4



Appendix A - Details of WD signal

GSM 835 MHz

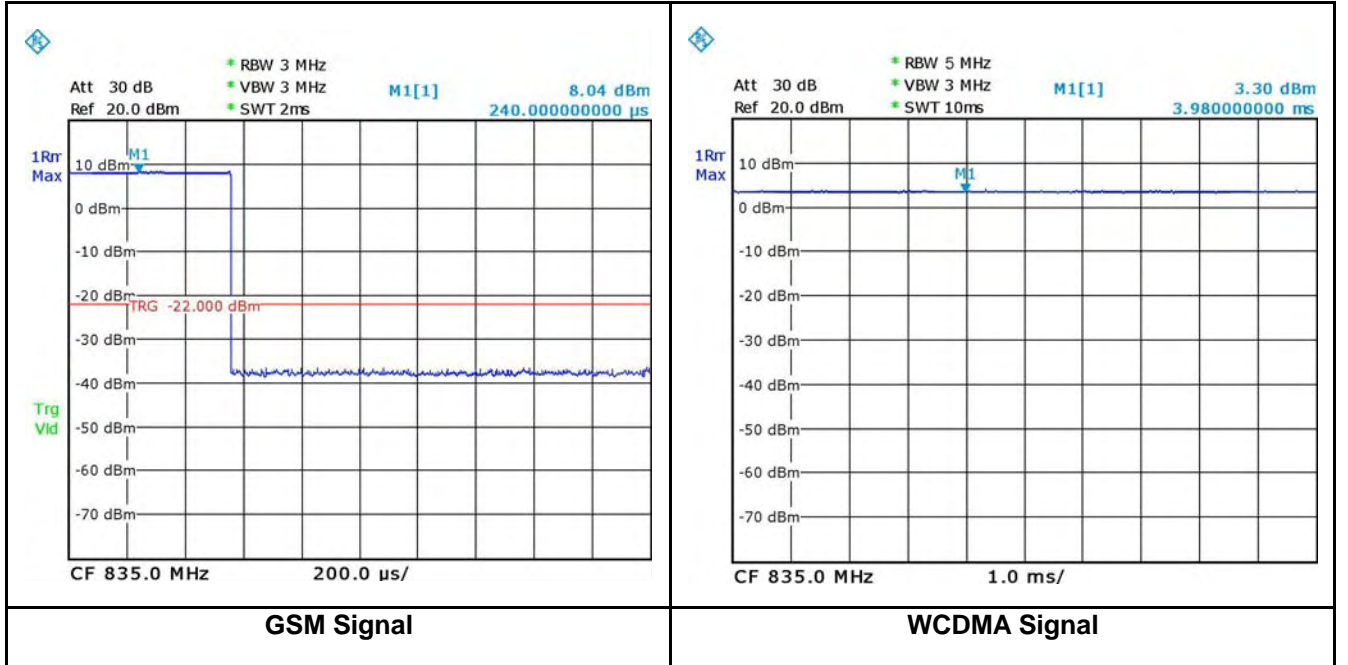
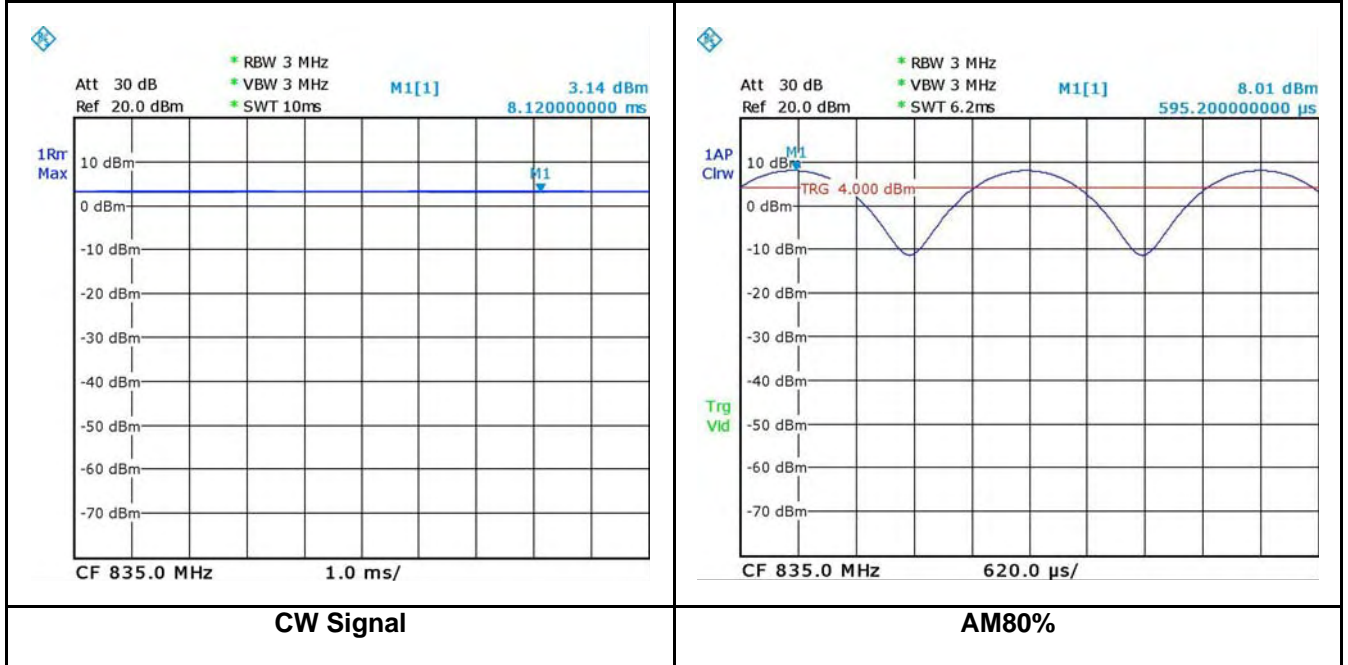



1880 MHz

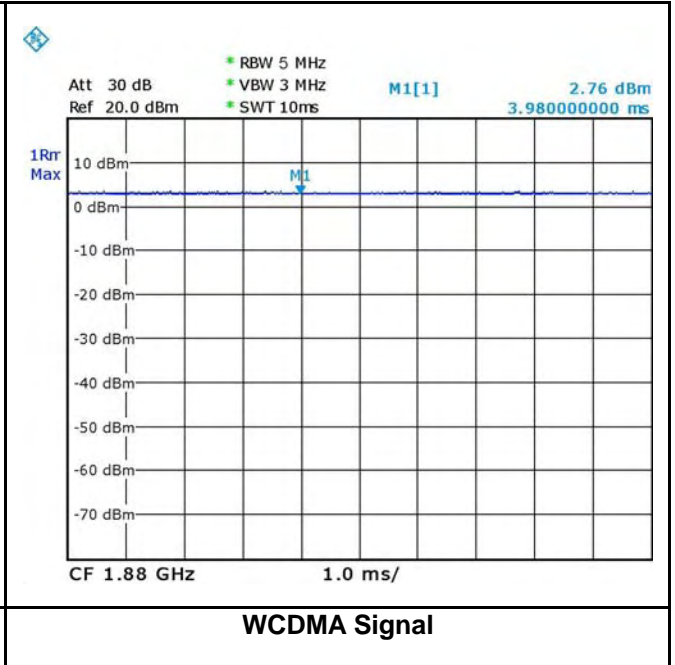
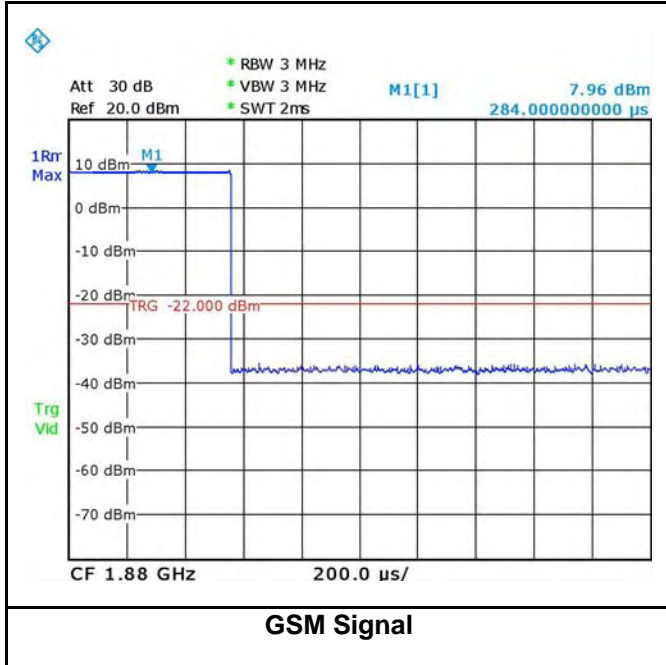
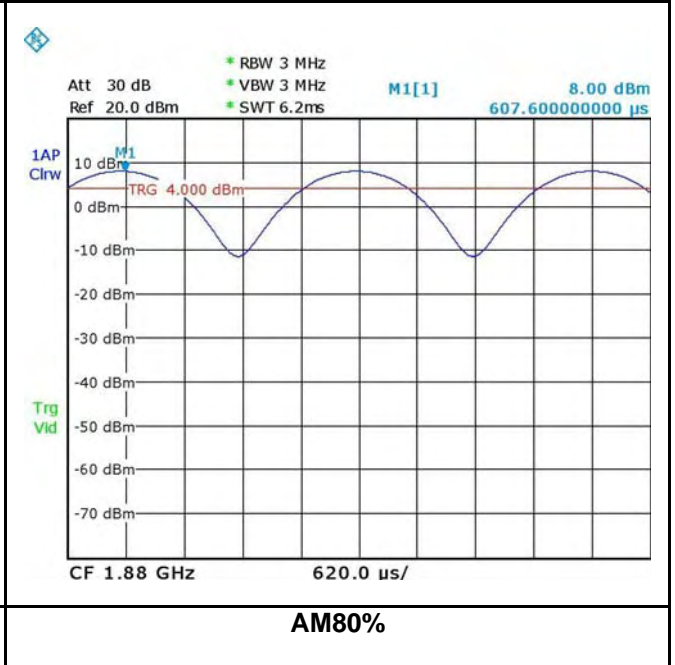
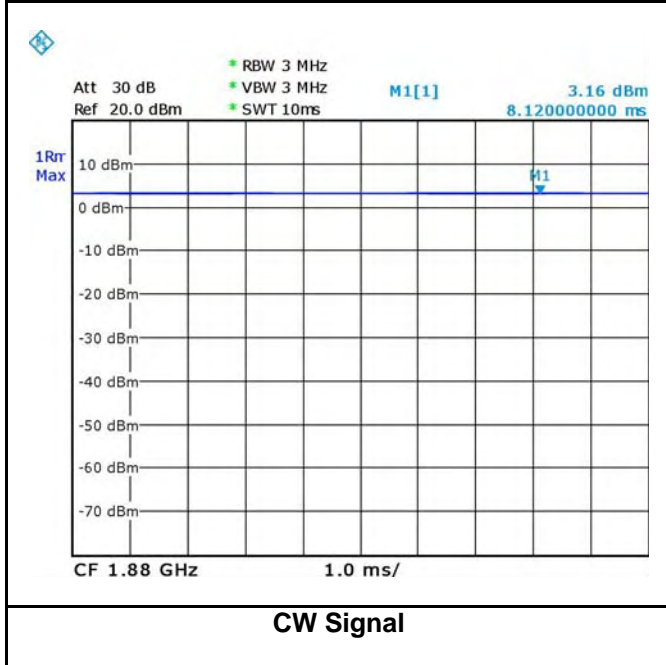



Appendix B - Validation

Test Laboratory: A Test Lab Techno Corp.

Date/Time: 8/26/2010 9:32:03 AM

HAC_System Performance Check at 835MHz_20100826_E

DUT: Dipole 835 MHz; Type: CD835V3; Serial: CD835V3 - SN:1017

Communication System: CW; Frequency: 835 MHz; Duty Cycle: 1:1

Medium parameters used: $\sigma = 0$ mho/m, $\epsilon_r = 1$; $\rho = 1000$ kg/m³

Phantom section: E Dipole Section

Measurement Standard: DASYS (IEEE/IEC)

DASY5 Configuration:

- Probe: ER3DV6 - SN2302; ConvF(1, 1, 1); Calibrated: 6/15/2010
- Sensor-Surface: (Fix Surface)
- Electronics: DAE4 Sn779; Calibrated: 1/21/2010
- Phantom: HAC Test Arch 4.6; Type: SD HAC P01 BA; Serial: 1038
- Measurement SW: DASYS, V5.0 Build 125; SEMCAD X Version 13.4 Build 125

E Scan - ER3DV6 - measurement distance from the probe sensor center to CD835

Dipole = 10mm/Hearing Aid Compatibility Test (41x361x1): Measurement grid:

dx=5mm, dy=5mm

Maximum value of peak Total field = 167.2 V/m

Probe Modulation Factor = 1

Device Reference Point: 0, 0, 354.7 mm

Reference Value = 119.9 V/m; Power Drift = -0.010 dB

Hearing Aid Near-Field Category: M4 (AWF 0 dB)

Peak E-field in V/m

Grid 1	Grid 2	Grid 3
161.6 M4	167.2 M4	161.6 M4
Grid 4	Grid 5	Grid 6
83 M4	87.2 M4	85.8 M4
Grid 7	Grid 8	Grid 9
150.3 M4	158.6 M4	157.0 M4

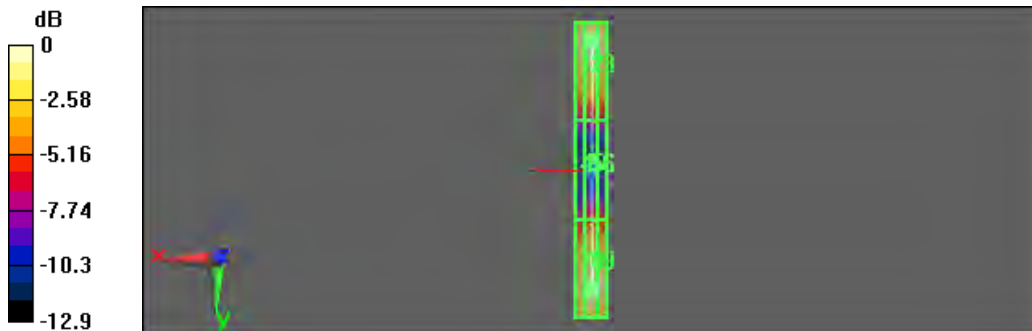



Test Laboratory: A Test Lab Techno Corp.

Date/Time: 10/12/2010 1:53:57 PM

HAC_System Performance Check at 835MHz_20101012_E

DUT: Dipole 835 MHz; Type: CD835V3; Serial: CD835V3 - SN:1017

Communication System: CW; Frequency: 835 MHz; Duty Cycle: 1:1

Medium parameters used: $\sigma = 0$ mho/m, $\epsilon_r = 1$; $\rho = 1000$ kg/m³

Phantom section: E Dipole Section

Measurement Standard: DASYS (IEEE/IEC)

DASY5 Configuration:

- Probe: ER3DV6R - SN2256; ConvF(1, 1, 1); Calibrated: 8/23/2010
- Sensor-Surface: (Fix Surface)
- Electronics: DAE4 Sn779; Calibrated: 1/21/2010
- Phantom: HAC Test Arch 4.6; Type: SD HAC P01 BA; Serial: 1038
- Measurement SW: DASYS, V5.0 Build 125; SEMCAD X Version 13.4 Build 125

E Scan - ER3DV6 - measurement distance from the probe sensor center to CD835

Dipole = 10mm/Hearing Aid Compatibility Test (41x361x1): Measurement grid:

dx=5mm, dy=5mm

Maximum value of peak Total field = 170.6 V/m

Probe Modulation Factor = 1

Device Reference Point: 0, 0, 354.7 mm

Reference Value = 130.3 V/m; Power Drift = -0.031 dB

Hearing Aid Near-Field Category: M4 (AWF 0 dB)

Peak E-field in V/m

Grid 1 165.7 M4	Grid 2 169.1 M4	Grid 3 159.0 M4
Grid 4 90.9 M4	Grid 5 93.4 M4	Grid 6 89.7 M4
Grid 7 165.0 M4	Grid 8 170.6 M4	Grid 9 163.8 M4

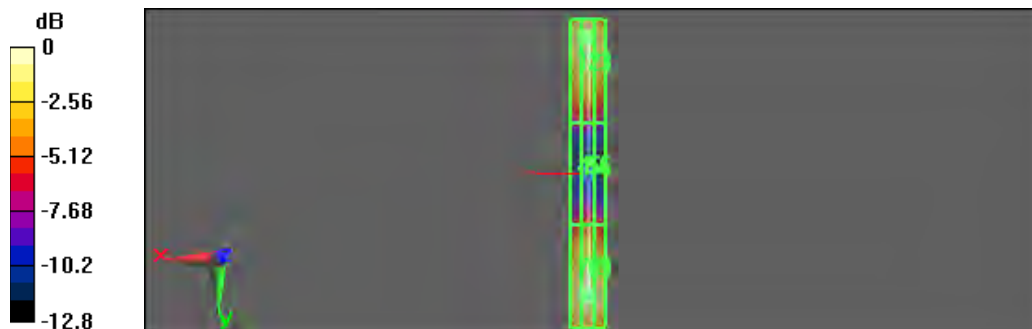

0 dB = 170.6V/m



Test Laboratory: A Test Lab Techno Corp.

Date/Time: 8/26/2010 10:23:05 AM

HAC_System Performance Check at 1880MHz_20100826_E

DUT: Dipole 1880 MHz; Type: CD1880V3; Serial: CD1880V3 - SN:1036

Communication System: CW; Frequency: 1880 MHz; Duty Cycle: 1:1

Medium parameters used: $\sigma = 0$ mho/m, $\epsilon_r = 1$; $\rho = 1000$ kg/m³

Phantom section: E Dipole Section

Measurement Standard: DASYS (IEEE/IEC)

DASY5 Configuration:

- Probe: ER3DV6 - SN2302; ConvF(1, 1, 1); Calibrated: 6/15/2010
- Sensor-Surface: (Fix Surface)
- Electronics: DAE4 Sn779; Calibrated: 1/21/2010
- Phantom: HAC Test Arch 4.6; Type: SD HAC P01 BA; Serial: 1038
- Measurement SW: DASYS, V5.0 Build 125; SEMCAD X Version 13.4 Build 125

E Scan - ER3DV6 - measurement distance from the probe sensor center to CD1880

Dipole = 10mm/Hearing Aid Compatibility Test (41x181x1): Measurement grid:

dx=5mm, dy=5mm

Maximum value of peak Total field = 137.1 V/m

Probe Modulation Factor = 1

Device Reference Point: 0, 0, 354.7 mm

Reference Value = 136.1 V/m; Power Drift = 0.031 dB

Hearing Aid Near-Field Category: M2 (AWF 0 dB)

Peak E-field in V/m

Grid 1 134.2 M2	Grid 2 137.1 M2	Grid 3 130.6 M2
Grid 4 86.1 M3	Grid 5 90 M3	Grid 6 88.2 M3
Grid 7 128.7 M2	Grid 8 133.1 M2	Grid 9 130.0 M2

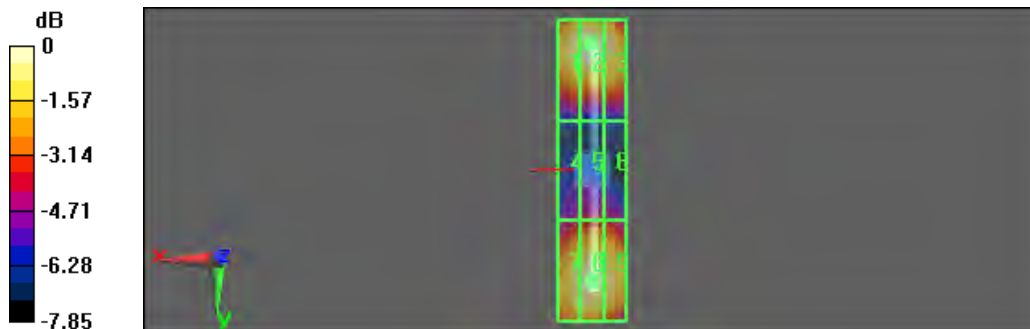

0 dB = 137.1V/m



Test Laboratory: A Test Lab Techno Corp.

Date/Time: 10/12/2010 3:12:47 PM

HAC_System Performance Check at 1880MHz_20101012_E

DUT: Dipole 1880 MHz; Type: CD1880V3; Serial: CD1880V3 - SN:1036

Communication System: CW; Frequency: 1880 MHz; Duty Cycle: 1:1

Medium parameters used: $\sigma = 0$ mho/m, $\epsilon_r = 1$; $\rho = 1000$ kg/m³

Phantom section: E Dipole Section

Measurement Standard: DASYS (IEEE/IEC)

DASY5 Configuration:

- Probe: ER3DV6R - SN2256; ConvF(1, 1, 1); Calibrated: 8/23/2010
- Sensor-Surface: (Fix Surface)
- Electronics: DAE4 Sn779; Calibrated: 1/21/2010
- Phantom: HAC Test Arch 4.6; Type: SD HAC P01 BA; Serial: 1038
- Measurement SW: DASYS, V5.0 Build 125; SEMCAD X Version 13.4 Build 125

E Scan - ER3DV6 - measurement distance from the probe sensor center to CD1880

Dipole = 10mm/Hearing Aid Compatibility Test (41x181x1): Measurement grid:

dx=5mm, dy=5mm

Maximum value of peak Total field = 148.2 V/m

Probe Modulation Factor = 1

Device Reference Point: 0, 0, 354.7 mm

Reference Value = 141.4 V/m; Power Drift = 0.020 dB

Hearing Aid Near-Field Category: M2 (AWF 0 dB)

Peak E-field in V/m

Grid 1 144.2 M2	Grid 2 148.2 M2	Grid 3 137.3 M2
Grid 4 92.2 M3	Grid 5 95.6 M3	Grid 6 92.1 M3
Grid 7 137.0 M2	Grid 8 139.5 M2	Grid 9 132.7 M2

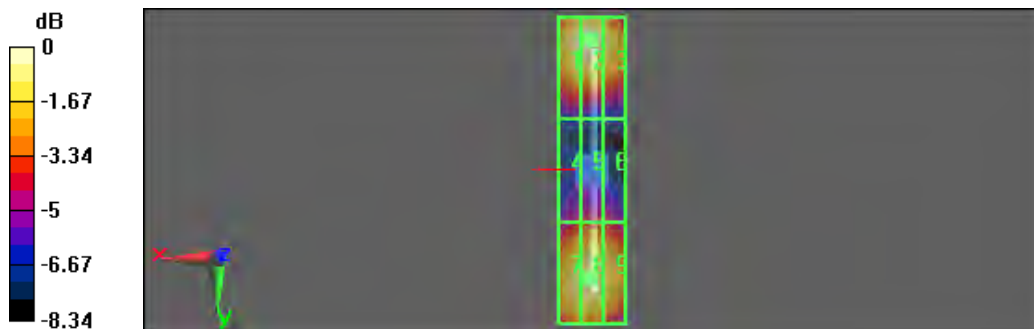

0 dB = 148.2V/m



Test Laboratory: A Test Lab Techno Corp.

Date/Time: 8/26/2010 9:54:28 AM

HAC_System Performance Check at 835MHz_20100826_H

DUT: Dipole 835 MHz; Type: CD835V3; Serial: CD835V3 - SN:1017

Communication System: CW; Frequency: 835 MHz; Duty Cycle: 1:1

Medium parameters used: $\sigma = 0$ mho/m, $\epsilon_r = 1$; $\rho = 1$ kg/m³

Phantom section: H Dipole Section

Measurement Standard: DASYS (IEEE/IEC)

DASY5 Configuration:

- Probe: H3DV6 - SN6187; ; Calibrated: 6/15/2010
- Sensor-Surface: (Fix Surface)
- Electronics: DAE4 Sn779; Calibrated: 1/21/2010
- Phantom: HAC Test Arch 4.6; Type: SD HAC P01 BA; Serial: 1038
- Measurement SW: DASYS, V5.0 Build 125; SEMCAD X Version 13.4 Build 125

H Scan - H3DV6 - measurement distance from the probe sensor center to CD835

Dipole = 10mm/Hearing Aid Compatibility Test (41x361x1): Measurement grid:

dx=5mm, dy=5mm

Maximum value of peak Total field = 0.459 A/m

Probe Modulation Factor = 1

Device Reference Point: 0, 0, 354.7 mm

Reference Value = 0.486 A/m; Power Drift = 0.015 dB

Hearing Aid Near-Field Category: M4 (AWF 0 dB)

Peak H-field in A/m

Grid 1 0.392 M4	Grid 2 0.409 M4	Grid 3 0.388 M4
Grid 4 0.439 M4	Grid 5 0.459 M4	Grid 6 0.439 M4
Grid 7 0.384 M4	Grid 8 0.406 M4	Grid 9 0.389 M4

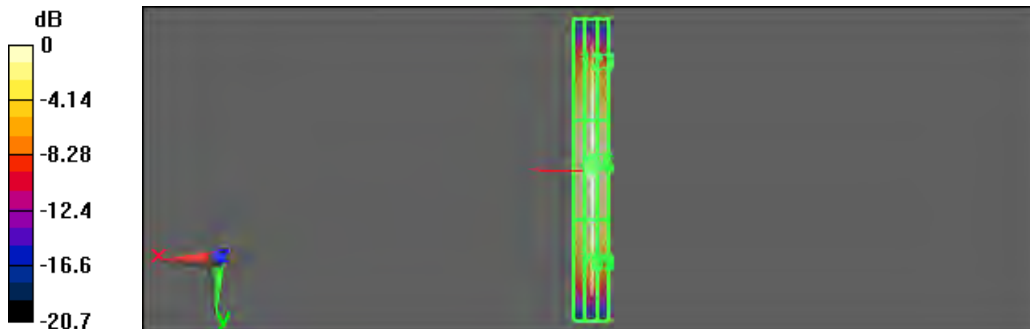

0 dB = 0.459A/m



Test Laboratory: A Test Lab Techno Corp.

Date/Time: 10/12/2010 2:14:41 PM

HAC_System Performance Check at 835MHz_20101012_H

DUT: Dipole 835 MHz; Type: CD835V3; Serial: CD835V3 - SN:1017

Communication System: CW; Frequency: 835 MHz; Duty Cycle: 1:1

Medium parameters used: $\sigma = 0$ mho/m, $\epsilon_r = 1$; $\rho = 1$ kg/m³

Phantom section: H Dipole Section

Measurement Standard: DASYS (IEEE/IEC)

DASY5 Configuration:

- Probe: H3DV6 - SN6076; ; Calibrated: 8/23/2010
- Sensor-Surface: (Fix Surface)
- Electronics: DAE4 Sn779; Calibrated: 1/21/2010
- Phantom: HAC Test Arch 4.6; Type: SD HAC P01 BA; Serial: 1038
- Measurement SW: DASYS, V5.0 Build 125; SEMCAD X Version 13.4 Build 125

H Scan - H3DV6 - measurement distance from the probe sensor center to CD835

Dipole = 10mm/Hearing Aid Compatibility Test (41x361x1): Measurement grid:

dx=5mm, dy=5mm

Maximum value of peak Total field = 0.465 A/m

Probe Modulation Factor = 1

Device Reference Point: 0, 0, 354.7 mm

Reference Value = 0.491 A/m; Power Drift = -0.021 dB

Hearing Aid Near-Field Category: M4 (AWF 0 dB)

Peak H-field in A/m

Grid 1 0.381 M4	Grid 2 0.416 M4	Grid 3 0.405 M4
Grid 4 0.428 M4	Grid 5 0.465 M4	Grid 6 0.454 M4
Grid 7 0.370 M4	Grid 8 0.408 M4	Grid 9 0.402 M4

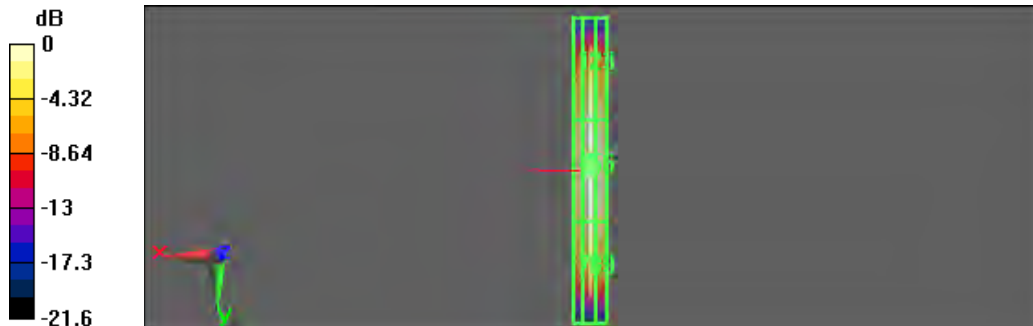

0 dB = 0.465A/m



Test Laboratory: A Test Lab Techno Corp.

Date/Time: 8/26/2010 10:09:12 AM

HAC_System Performance Check at 1880MHz_20100826_H

DUT: Dipole 1880 MHz; Type: CD1880V3; Serial: CD1880V3 - SN:1036

Communication System: CW; Frequency: 1880 MHz; Duty Cycle: 1:1

Medium parameters used: $\sigma = 0$ mho/m, $\epsilon_r = 1$; $\rho = 1$ kg/m³

Phantom section: H Dipole Section

Measurement Standard: DASYS5 (IEEE/IEC)

DASY5 Configuration:

- Probe: H3DV6 - SN6187; ; Calibrated: 6/15/2010
- Sensor-Surface: (Fix Surface)
- Electronics: DAE4 Sn779; Calibrated: 1/21/2010
- Phantom: HAC Test Arch 4.6; Type: SD HAC P01 BA; Serial: 1038
- Measurement SW: DASYS5, V5.0 Build 125; SEMCAD X Version 13.4 Build 125

H Scan - H3DV6 - measurement distance from the probe sensor center to CD1880

Dipole = 10mm/Hearing Aid Compatibility Test (41x181x1): Measurement grid:

dx=5mm, dy=5mm

Maximum value of peak Total field = 0.459 A/m

Probe Modulation Factor = 1

Device Reference Point: 0, 0, 354.7 mm

Reference Value = 0.487 A/m; Power Drift = -0.066 dB

Hearing Aid Near-Field Category: M2 (AWF 0 dB)

Peak H-field in A/m

Grid 1 0.400 M2	Grid 2 0.414 M2	Grid 3 0.391 M2
Grid 4 0.442 M2	Grid 5 0.459 M2	Grid 6 0.436 M2
Grid 7 0.406 M2	Grid 8 0.423 M2	Grid 9 0.402 M2

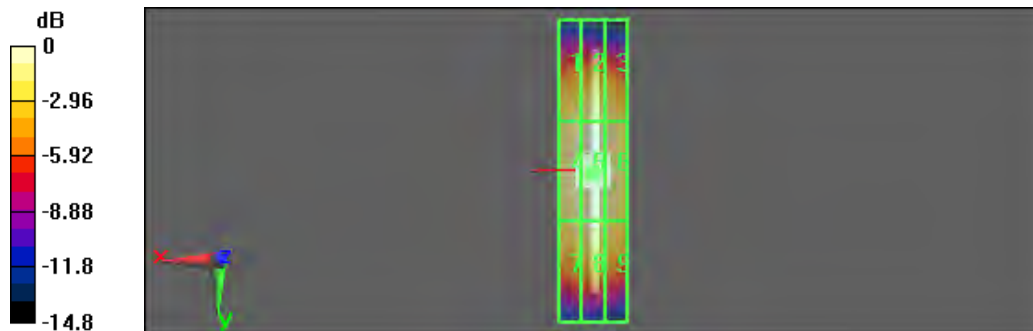

0 dB = 0.459A/m



Test Laboratory: A Test Lab Techno Corp.

Date/Time: 10/12/2010 2:53:53 PM

HAC_System Performance Check at 1880MHz_20101012_H

DUT: Dipole 1880 MHz; Type: CD1880V3; Serial: CD1880V3 - SN:1036

Communication System: CW; Frequency: 1880 MHz; Duty Cycle: 1:1

Medium parameters used: $\sigma = 0$ mho/m, $\epsilon_r = 1$; $\rho = 1$ kg/m³

Phantom section: H Dipole Section

Measurement Standard: DASYS5 (IEEE/IEC)

DASY5 Configuration:

- Probe: H3DV6 - SN6076; ; Calibrated: 8/23/2010
- Sensor-Surface: (Fix Surface)
- Electronics: DAE4 Sn779; Calibrated: 1/21/2010
- Phantom: HAC Test Arch 4.6; Type: SD HAC P01 BA; Serial: 1038
- Measurement SW: DASYS5, V5.0 Build 125; SEMCAD X Version 13.4 Build 125

H Scan - H3DV6 - measurement distance from the probe sensor center to CD1880

Dipole = 10mm/Hearing Aid Compatibility Test (41x181x1): Measurement grid:

dx=5mm, dy=5mm

Maximum value of peak Total field = 0.465 A/m

Probe Modulation Factor = 1

Device Reference Point: 0, 0, 354.7 mm

Reference Value = 0.487 A/m; Power Drift = 0.00438 dB

Hearing Aid Near-Field Category: M2 (AWF 0 dB)

Peak H-field in A/m

Grid 1 0.399 M2	Grid 2 0.432 M2	Grid 3 0.420 M2
Grid 4 0.432 M2	Grid 5 0.465 M2	Grid 6 0.453 M2
Grid 7 0.385 M2	Grid 8 0.416 M2	Grid 9 0.408 M2

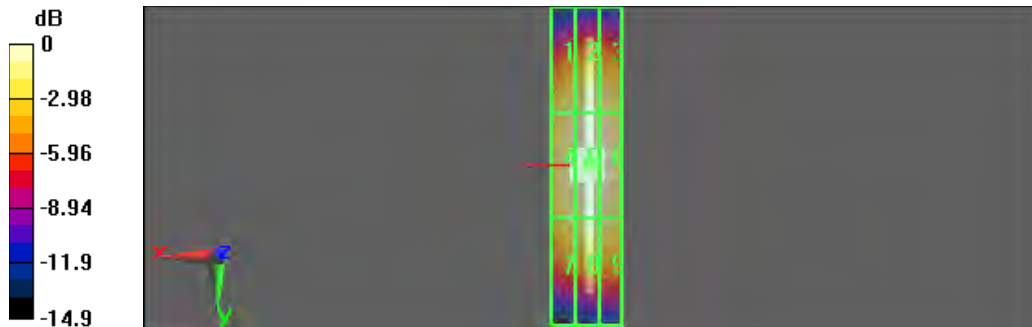

0 dB = 0.465A/m



Appendix C - HAC distribution plots for E-Field and H-Field

Test Laboratory: A Test Lab Techno Corp.

Date/Time: 8/26/2010 11:30:32 AM

HAC_GSM850 CH128_E

DUT: PD98120; Type: Mobile Phone; FCC ID: NM8PD98120

Communication System: GSM850; Frequency: 824.2 MHz; Duty Cycle: 1:8.3

Medium parameters used: $\sigma = 0$ mho/m, $\epsilon_r = 1$; $\rho = 1000$ kg/m³

Phantom section: E Device Section

Measurement Standard: DASYS (IEEE/IEC)

DASY5 Configuration:

- Probe: ER3DV6 - SN2302; ConvF(1, 1, 1); Calibrated: 6/15/2010
- Sensor-Surface: (Fix Surface)
- Electronics: DAE4 Sn779; Calibrated: 1/21/2010
- Phantom: HAC Test Arch 4.6; Type: SD HAC P01 BA; Serial: 1038
- Measurement SW: DASYS, V5.0 Build 125; SEMCAD X Version 13.4 Build 125

E Scan - ER3DV6 - measurement distance from the probe sensor center to the Device = 15mm/Hearing Aid Compatibility Test (101x101x1): Measurement grid: dx=5mm, dy=5mm

Maximum value of peak Total field = 132.8 V/m

Probe Modulation Factor = 2.56

Device Reference Point: 0, 0, 353.7 mm

Reference Value = 64.7 V/m; Power Drift = 0.046 dB

Hearing Aid Near-Field Category: M4 (AWF -5 dB)

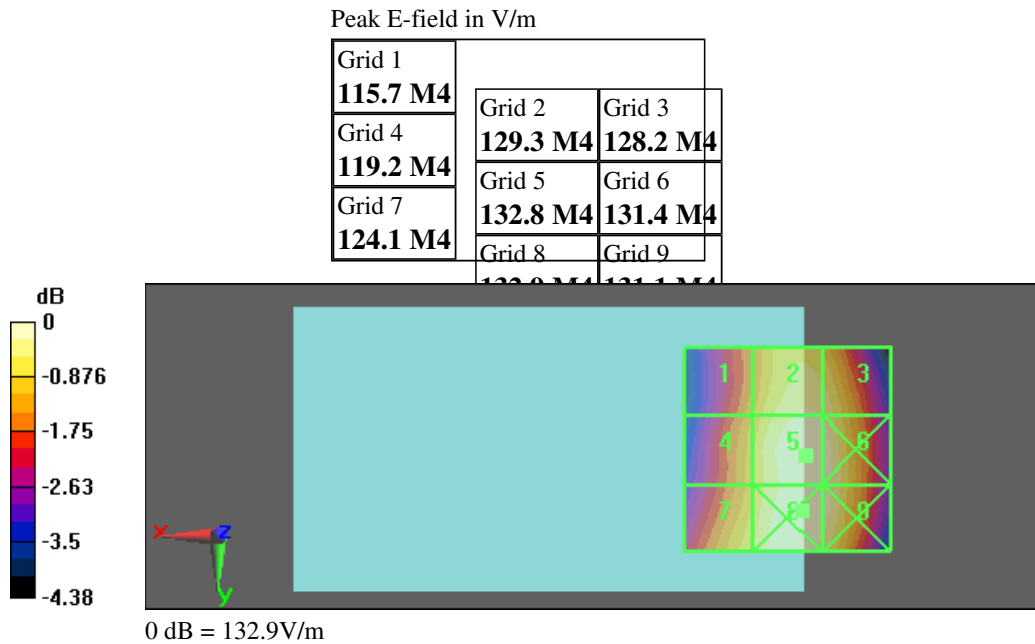



Test Laboratory: A Test Lab Techno Corp.

Date/Time: 8/26/2010 11:40:59 AM

HAC_GSM850 CH190_E

DUT: PD98120; Type: Mobile Phone; FCC ID: NM8PD98120

Communication System: GSM850; Frequency: 836.6 MHz; Duty Cycle: 1:8.3

Medium parameters used: $\sigma = 0$ mho/m, $\epsilon_r = 1$; $\rho = 1000$ kg/m³

Phantom section: E Device Section

Measurement Standard: DASYS (IEEE/IEC)

DASY5 Configuration:

- Probe: ER3DV6 - SN2302; ConvF(1, 1, 1); Calibrated: 6/15/2010
- Sensor-Surface: (Fix Surface)
- Electronics: DAE4 Sn779; Calibrated: 1/21/2010
- Phantom: HAC Test Arch 4.6; Type: SD HAC P01 BA; Serial: 1038
- Measurement SW: DASYS, V5.0 Build 125; SEMCAD X Version 13.4 Build 125

E Scan - ER3DV6 - measurement distance from the probe sensor center to the Device = 15mm/Hearing Aid Compatibility Test (101x101x1): Measurement grid: dx=5mm, dy=5mm

Maximum value of peak Total field = 134.3 V/m

Probe Modulation Factor = 2.56

Device Reference Point: 0, 0, 353.7 mm

Reference Value = 65.7 V/m; Power Drift = -0.00829 dB

Hearing Aid Near-Field Category: M4 (AWF -5 dB)

Peak E-field in V/m

Grid 1 116.4 M4	Grid 2 129.9 M4	Grid 3 128.5 M4
Grid 4 120.6 M4	Grid 5 134.3 M4	Grid 6 132.4 M4
Grid 7 125.9 M4	Grid 8 135.0 M4	Grid 9 132.5 M4

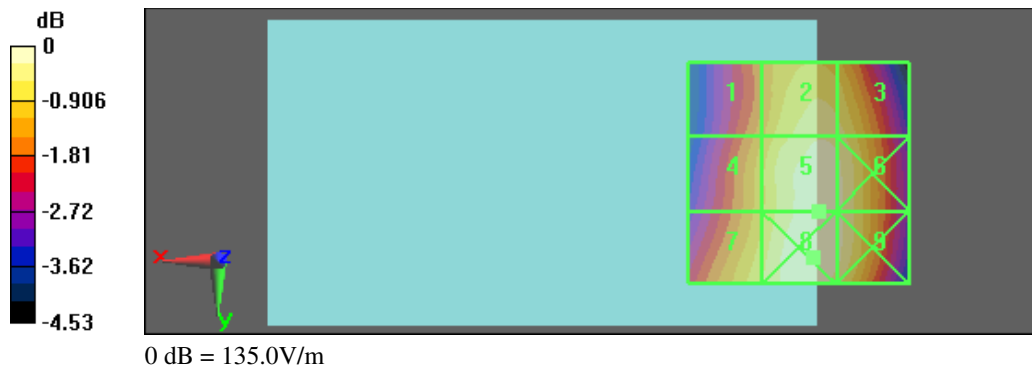



Test Laboratory: A Test Lab Techno Corp.

Date/Time: 8/26/2010 11:48:38 AM

HAC_GSM850 CH251_E

DUT: PD98120; Type: Mobile Phone; FCC ID: NM8PD98120

Communication System: GSM850; Frequency: 848.8 MHz; Duty Cycle: 1:8.3

Medium parameters used: $\sigma = 0$ mho/m, $\epsilon_r = 1$; $\rho = 1000$ kg/m³

Phantom section: E Device Section

Measurement Standard: DASYS (IEEE/IEC)

DASY5 Configuration:

- Probe: ER3DV6 - SN2302; ConvF(1, 1, 1); Calibrated: 6/15/2010
- Sensor-Surface: (Fix Surface)
- Electronics: DAE4 Sn779; Calibrated: 1/21/2010
- Phantom: HAC Test Arch 4.6; Type: SD HAC P01 BA; Serial: 1038
- Measurement SW: DASYS, V5.0 Build 125; SEMCAD X Version 13.4 Build 125

E Scan - ER3DV6 - measurement distance from the probe sensor center to the Device = 15mm/Hearing Aid Compatibility Test (101x101x1): Measurement grid: dx=5mm, dy=5mm

Maximum value of peak Total field = 148.5 V/m

Probe Modulation Factor = 2.56

Device Reference Point: 0, 0, 353.7 mm

Reference Value = 72.4 V/m; Power Drift = -0.089 dB

Hearing Aid Near-Field Category: M4 (AWF -5 dB)

Peak E-field in V/m

Grid 1 126.5 M4	Grid 2 144.3 M4	Grid 3 142.9 M4
Grid 4 132.2 M4	Grid 5 148.5 M4	Grid 6 147.0 M4
Grid 7 138.3 M4	Grid 8 149.0 M4	Grid 9 146.9 M4

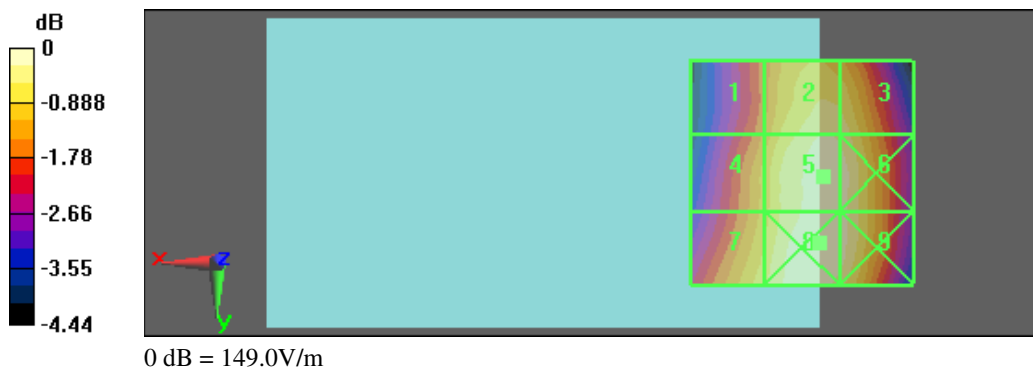



Test Laboratory: A Test Lab Techno Corp.

Date/Time: 10/12/2010 3:57:53 PM

HAC_GSM850_CH251_E _ #2 GSM Power Amplifier

DUT: PD98120; Type: Mobile Phone; FCC ID: NM8PD98120

Communication System: GSM850; Frequency: 848.8 MHz; Duty Cycle: 1:8.3

Medium parameters used: $\sigma = 0$ mho/m, $\epsilon_r = 1$; $\rho = 1000$ kg/m³

Phantom section: E Device Section

Measurement Standard: DASYS (IEEE/IEC)

DASY5 Configuration:

- Probe: ER3DV6R - SN2256; ConvF(1, 1, 1); Calibrated: 8/23/2010
- Sensor-Surface: (Fix Surface)
- Electronics: DAE4 Sn779; Calibrated: 1/21/2010
- Phantom: HAC Test Arch 4.6; Type: SD HAC P01 BA; Serial: 1038
- Measurement SW: DASYS, V5.0 Build 125; SEMCAD X Version 13.4 Build 125

E Scan - ER3DV6 - measurement distance from the probe sensor center to the Device = 15mm/Hearing Aid Compatibility Test (101x101x1): Measurement grid: dx=5mm, dy=5mm

Maximum value of peak Total field = 153.6 V/m

Probe Modulation Factor = 2.56

Device Reference Point: 0, 0, 353.7 mm

Reference Value = 74.1 V/m; Power Drift = -0.00298 dB

Hearing Aid Near-Field Category: M3 (AWF -5 dB)

Peak E-field in V/m

Grid 1 130.4 M4	Grid 2 147.9 M4	Grid 3 146.2 M4
Grid 4 137.1 M4	Grid 5 153.6 M3	Grid 6 151.5 M3
Grid 7 147.4 M4	Grid 8 156.0 M3	Grid 9 152.6 M3





Test Laboratory: A Test Lab Techno Corp.

Date/Time: 8/26/2010 12:20:35 PM

HAC_PCS CH512_E

DUT: PD98120; Type: Mobile Phone; FCC ID: NM8PD98120

Communication System: PCS; Frequency: 1850.2 MHz; Duty Cycle: 1:8.3

Medium parameters used: $\sigma = 0$ mho/m, $\epsilon_r = 1$; $\rho = 1000$ kg/m³

Phantom section: E Device Section

Measurement Standard: DASYS (IEEE/IEC)

DASY5 Configuration:

- Probe: ER3DV6 - SN2302; ConvF(1, 1, 1); Calibrated: 6/15/2010
- Sensor-Surface: (Fix Surface)
- Electronics: DAE4 Sn779; Calibrated: 1/21/2010
- Phantom: HAC Test Arch 4.6; Type: SD HAC P01 BA; Serial: 1038
- Measurement SW: DASYS, V5.0 Build 125; SEMCAD X Version 13.4 Build 125

E Scan - ER3DV6 - measurement distance from the probe sensor center to the Device = 15mm/Hearing Aid Compatibility Test (101x101x1): Measurement grid: dx=5mm, dy=5mm

Maximum value of peak Total field = 59.2 V/m

Probe Modulation Factor = 2.5

Device Reference Point: 0, 0, 353.7 mm

Reference Value = 20.9 V/m; Power Drift = -0.103 dB

Hearing Aid Near-Field Category: M3 (AWF -5 dB)

Peak E-field in V/m

Grid 1	Grid 2	Grid 3
59.2 M3	58.8 M3	56.1 M3
Grid 4	Grid 5	Grid 6
36.5 M4	58.9 M3	60 M3
Grid 7	Grid 8	Grid 9
50.2 M3	72.1 M3	72.1 M3

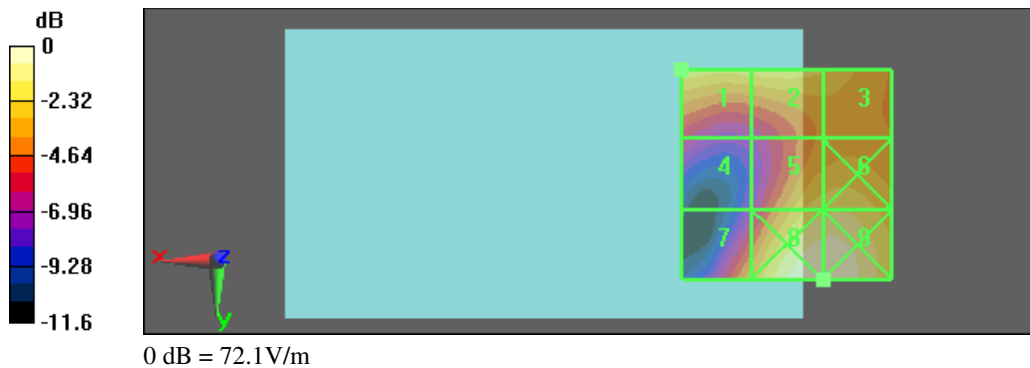



Test Laboratory: A Test Lab Techno Corp.

Date/Time: 8/26/2010 12:57:53 PM

HAC_PCS CH661_E

DUT: PD98120; Type: Mobile Phone; FCC ID: NM8PD98120

Communication System: PCS; Frequency: 1880 MHz; Duty Cycle: 1:8.3

Medium parameters used: $\sigma = 0$ mho/m, $\epsilon_r = 1$; $\rho = 1000$ kg/m³

Phantom section: E Device Section

Measurement Standard: DASYS (IEEE/IEC)

DASY5 Configuration:

- Probe: ER3DV6 - SN2302; ConvF(1, 1, 1); Calibrated: 6/15/2010
- Sensor-Surface: (Fix Surface)
- Electronics: DAE4 Sn779; Calibrated: 1/21/2010
- Phantom: HAC Test Arch 4.6; Type: SD HAC P01 BA; Serial: 1038
- Measurement SW: DASYS, V5.0 Build 125; SEMCAD X Version 13.4 Build 125

E Scan - ER3DV6 - measurement distance from the probe sensor center to the Device = 15mm/Hearing Aid Compatibility Test (101x101x1): Measurement grid: dx=5mm, dy=5mm

Maximum value of peak Total field = 67.7 V/m

Probe Modulation Factor = 2.5

Device Reference Point: 0, 0, 353.7 mm

Reference Value = 22.6 V/m; Power Drift = 0.074 dB

Hearing Aid Near-Field Category: M3 (AWF -5 dB)

Peak E-field in V/m

Grid 1	Grid 2	Grid 3
66.1 M3	67.7 M3	64.6 M3
Grid 4	Grid 5	Grid 6
40.2 M4	64.5 M3	65.7 M3
Grid 7	Grid 8	Grid 9
54.3 M3	79.1 M3	79.1 M3

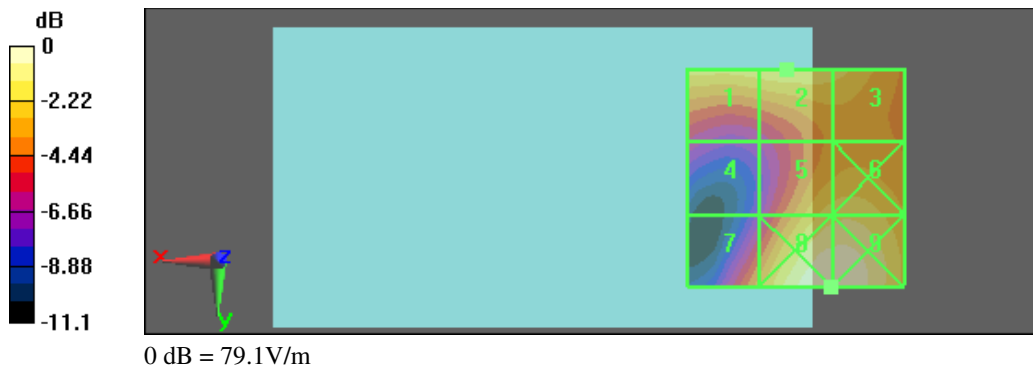



Test Laboratory: A Test Lab Techno Corp.

Date/Time: 10/12/2010 4:06:59 PM

HAC_PCS CH661_E _#2 GSM Power Amplifier

DUT: PD98120; Type: Mobile Phone; FCC ID: NM8PD98120

Communication System: PCS; Frequency: 1880 MHz; Duty Cycle: 1:8.3

Medium parameters used: $\sigma = 0$ mho/m, $\epsilon_r = 1$; $\rho = 1000$ kg/m³

Phantom section: E Device Section

Measurement Standard: DASYS (IEEE/IEC)

DASY5 Configuration:

- Probe: ER3DV6R - SN2256; ConvF(1, 1, 1); Calibrated: 8/23/2010
- Sensor-Surface: (Fix Surface)
- Electronics: DAE4 Sn779; Calibrated: 1/21/2010
- Phantom: HAC Test Arch 4.6; Type: SD HAC P01 BA; Serial: 1038
- Measurement SW: DASYS, V5.0 Build 125; SEMCAD X Version 13.4 Build 125

E Scan - ER3DV6 - measurement distance from the probe sensor center to the Device = 15mm/Hearing Aid Compatibility Test (101x101x1): Measurement grid: dx=5mm, dy=5mm

Maximum value of peak Total field = 72.9 V/m

Probe Modulation Factor = 2.5

Device Reference Point: 0, 0, 353.7 mm

Reference Value = 23.4 V/m; Power Drift = 0.088 dB

Hearing Aid Near-Field Category: M3 (AWF -5 dB)

Peak E-field in V/m

Grid 1	Grid 2	Grid 3
72.5 M3	72.9 M3	68.5 M3
Grid 4	Grid 5	Grid 6
45.8 M4	66.9 M3	68.6 M3
Grid 7	Grid 8	Grid 9
56.7 M3	83.4 M3	83.4 M3





Test Laboratory: A Test Lab Techno Corp.

Date/Time: 8/26/2010 1:05:14 PM

HAC_PCS CH810_E

DUT: PD98120; Type: Mobile Phone; FCC ID: NM8PD98120

Communication System: PCS; Frequency: 1909.8 MHz; Duty Cycle: 1:8.3

Medium parameters used: $\sigma = 0$ mho/m, $\epsilon_r = 1$; $\rho = 1000$ kg/m³

Phantom section: E Device Section

Measurement Standard: DASYS (IEEE/IEC)

DASY5 Configuration:

- Probe: ER3DV6 - SN2302; ConvF(1, 1, 1); Calibrated: 6/15/2010
- Sensor-Surface: (Fix Surface)
- Electronics: DAE4 Sn779; Calibrated: 1/21/2010
- Phantom: HAC Test Arch 4.6; Type: SD HAC P01 BA; Serial: 1038
- Measurement SW: DASYS, V5.0 Build 125; SEMCAD X Version 13.4 Build 125

E Scan - ER3DV6 - measurement distance from the probe sensor center to the Device = 15mm/Hearing Aid Compatibility Test (101x101x1): Measurement grid: dx=5mm, dy=5mm

Maximum value of peak Total field = 64.2 V/m

Probe Modulation Factor = 2.5

Device Reference Point: 0, 0, 353.7 mm

Reference Value = 20.5 V/m; Power Drift = 0.046 dB

Hearing Aid Near-Field Category: M3 (AWF -5 dB)

Peak E-field in V/m

Grid 1	Grid 2	Grid 3
62.4 M3	64.2 M3	63.1 M3
Grid 4	Grid 5	Grid 6
38 M4	59.5 M3	60.8 M3
Grid 7	Grid 8	Grid 9
50.1 M3	73.5 M3	73.5 M3

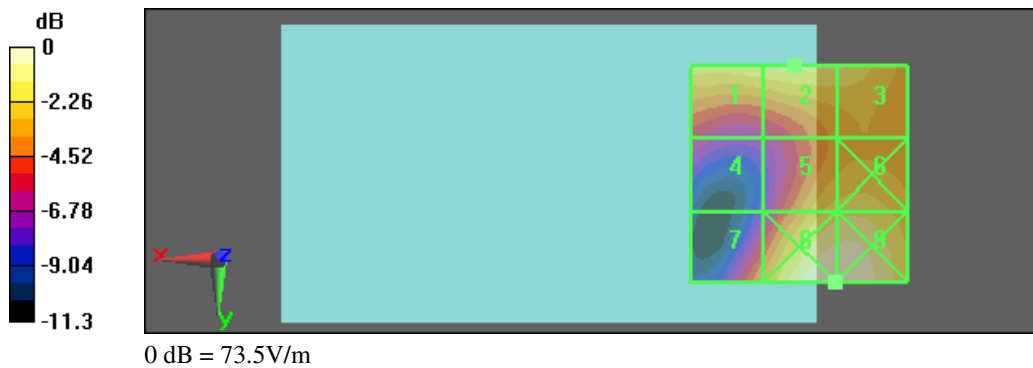



Test Laboratory: A Test Lab Techno Corp.

Date/Time: 8/26/2010 1:43:09 PM

HAC_WCDMA Band II CH9262_E

DUT: PD98120; Type: Mobile Phone; FCC ID: NM8PD98120

Communication System: WCDMA Band II; Frequency: 1852.4 MHz; Duty Cycle: 1:1

Medium parameters used: $\sigma = 0$ mho/m, $\epsilon_r = 1$; $\rho = 1000$ kg/m³

Phantom section: E Device Section

Measurement Standard: DASYS (IEEE/IEC)

DASY5 Configuration:

- Probe: ER3DV6 - SN2302; ConvF(1, 1, 1); Calibrated: 6/15/2010
- Sensor-Surface: (Fix Surface)
- Electronics: DAE4 Sn779; Calibrated: 1/21/2010
- Phantom: HAC Test Arch 4.6; Type: SD HAC P01 BA; Serial: 1038
- Measurement SW: DASYS, V5.0 Build 125; SEMCAD X Version 13.4 Build 125

E Scan - ER3DV6 - measurement distance from the probe sensor center to the Device = 15mm/Hearing Aid Compatibility Test (101x101x1): Measurement grid: dx=5mm, dy=5mm

Maximum value of peak Total field = 37.1 V/m

Probe Modulation Factor = 0.900

Device Reference Point: 0, 0, 353.7 mm

Reference Value = 35.2 V/m; Power Drift = 0.019 dB

Hearing Aid Near-Field Category: M4 (AWF 0 dB)

Peak E-field in V/m

Grid 1	Grid 2	Grid 3
36.9 M4	37.1 M4	35.2 M4
Grid 4	Grid 5	Grid 6
23 M4	36.7 M4	37.3 M4
Grid 7	Grid 8	Grid 9
30.9 M4	44.9 M4	44.9 M4





Test Laboratory: A Test Lab Techno Corp.

Date/Time: 8/26/2010 1:52:03 PM

HAC_WCDMA Band II CH9400_E

DUT: PD98120; Type: Mobile Phone; FCC ID: NM8PD98120

Communication System: WCDMA Band II; Frequency: 1880 MHz; Duty Cycle: 1:1

Medium parameters used: $\sigma = 0$ mho/m, $\epsilon_r = 1$; $\rho = 1000$ kg/m³

Phantom section: E Device Section

Measurement Standard: DASYS5 (IEEE/IEC)

DASY5 Configuration:

- Probe: ER3DV6 - SN2302; ConvF(1, 1, 1); Calibrated: 6/15/2010
- Sensor-Surface: (Fix Surface)
- Electronics: DAE4 Sn779; Calibrated: 1/21/2010
- Phantom: HAC Test Arch 4.6; Type: SD HAC P01 BA; Serial: 1038
- Measurement SW: DASYS5, V5.0 Build 125; SEMCAD X Version 13.4 Build 125

E Scan - ER3DV6 - measurement distance from the probe sensor center to the Device = 15mm/Hearing Aid Compatibility Test (101x101x1): Measurement grid: dx=5mm, dy=5mm

Maximum value of peak Total field = 38.3 V/m

Probe Modulation Factor = 0.900

Device Reference Point: 0, 0, 353.7 mm

Reference Value = 34.8 V/m; Power Drift = 0.108 dB

Hearing Aid Near-Field Category: M4 (AWF 0 dB)

Peak E-field in V/m

Grid 1	Grid 2	Grid 3
36.9 M4	38.3 M4	36.4 M4
Grid 4	Grid 5	Grid 6
22.6 M4	36.1 M4	36.7 M4
Grid 7	Grid 8	Grid 9
30.2 M4	44.3 M4	44.3 M4

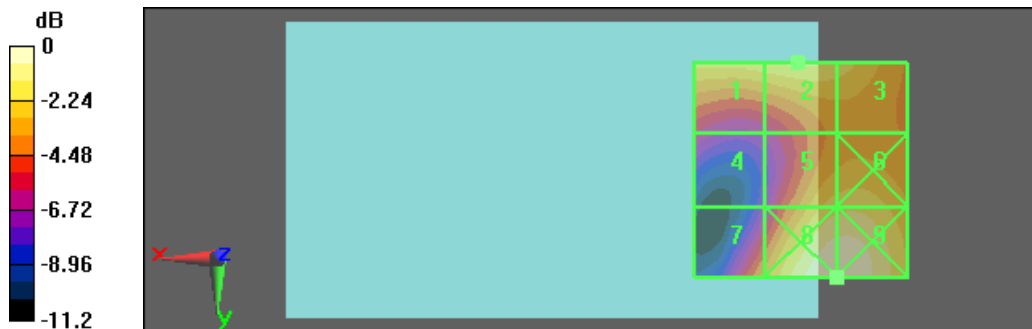

0 dB = 44.3V/m



Test Laboratory: A Test Lab Techno Corp.

Date/Time: 8/26/2010 2:02:06 PM

HAC_WCDMA Band II CH9538_E

DUT: PD98120; Type: Mobile Phone; FCC ID: NM8PD98120

Communication System: WCDMA Band II; Frequency: 1907.6 MHz; Duty Cycle: 1:1

Medium parameters used: $\sigma = 0$ mho/m, $\epsilon_r = 1$; $\rho = 1000$ kg/m³

Phantom section: E Device Section

Measurement Standard: DASYS (IEEE/IEC)

DASY5 Configuration:

- Probe: ER3DV6 - SN2302; ConvF(1, 1, 1); Calibrated: 6/15/2010
- Sensor-Surface: (Fix Surface)
- Electronics: DAE4 Sn779; Calibrated: 1/21/2010
- Phantom: HAC Test Arch 4.6; Type: SD HAC P01 BA; Serial: 1038
- Measurement SW: DASYS, V5.0 Build 125; SEMCAD X Version 13.4 Build 125

E Scan - ER3DV6 - measurement distance from the probe sensor center to the Device = 15mm/Hearing Aid Compatibility Test (101x101x1): Measurement grid: dx=5mm, dy=5mm

Maximum value of peak Total field = 35.7 V/m

Probe Modulation Factor = 0.900

Device Reference Point: 0, 0, 353.7 mm

Reference Value = 31.3 V/m; Power Drift = 0.017 dB

Hearing Aid Near-Field Category: M4 (AWF 0 dB)

Peak E-field in V/m

Grid 1	Grid 2	Grid 3
34.5 M4	35.7 M4	34.4 M4
Grid 4	Grid 5	Grid 6
20.9 M4	32.8 M4	33.5 M4
Grid 7	Grid 8	Grid 9
27.6 M4	40.5 M4	40.5 M4

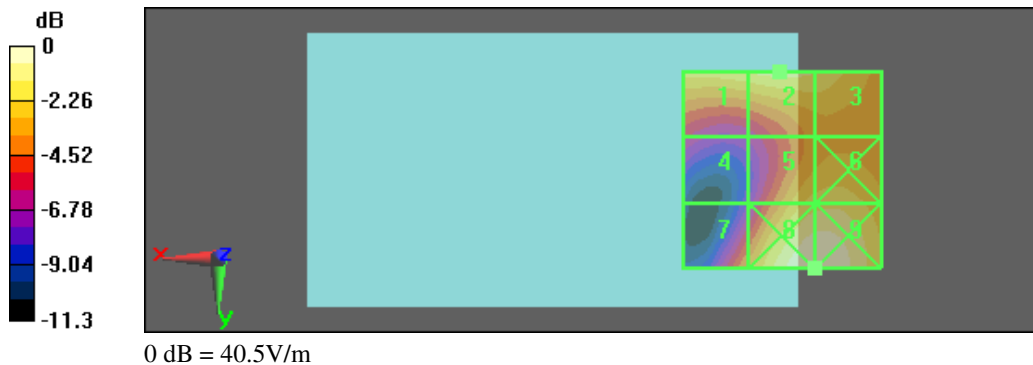



Test Laboratory: A Test Lab Techno Corp.

Date/Time: 8/26/2010 1:14:59 PM

HAC_WCDMA Band V CH4132_E

DUT: PD98120; Type: Mobile Phone; FCC ID: NM8PD98120

Communication System: WCDMA Band V; Frequency: 826.4 MHz; Duty Cycle: 1:1

Medium parameters used: $\sigma = 0$ mho/m, $\epsilon_r = 1$; $\rho = 1000$ kg/m³

Phantom section: E Device Section

Measurement Standard: DASYS (IEEE/IEC)

DASY5 Configuration:

- Probe: ER3DV6 - SN2302; ConvF(1, 1, 1); Calibrated: 6/15/2010
- Sensor-Surface: (Fix Surface)
- Electronics: DAE4 Sn779; Calibrated: 1/21/2010
- Phantom: HAC Test Arch 4.6; Type: SD HAC P01 BA; Serial: 1038
- Measurement SW: DASYS, V5.0 Build 125; SEMCAD X Version 13.4 Build 125

E Scan - ER3DV6 - measurement distance from the probe sensor center to the Device = 15mm/Hearing Aid Compatibility Test (101x101x1): Measurement grid: dx=5mm, dy=5mm

Maximum value of peak Total field = 58.6 V/m

Probe Modulation Factor = 1.04

Device Reference Point: 0, 0, 353.7 mm

Reference Value = 72 V/m; Power Drift = 0.136 dB

Hearing Aid Near-Field Category: M4 (AWF 0 dB)

Peak E-field in V/m

Grid 1	Grid 2	Grid 3
51.2 M4	57 M4	56.2 M4
Grid 4	Grid 5	Grid 6
53 M4	58.6 M4	57.7 M4
Grid 7	Grid 8	Grid 9
55.1 M4	58.6 M4	57.6 M4

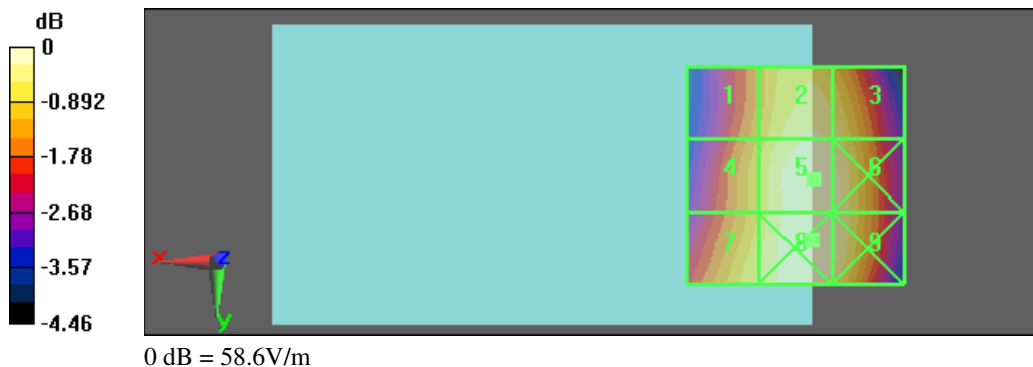



Test Laboratory: A Test Lab Techno Corp.

Date/Time: 8/26/2010 1:28:33 PM

HAC_WCDMA Band V CH4183_E

DUT: PD98120; Type: Mobile Phone; FCC ID: NM8PD98120

Communication System: WCDMA Band V; Frequency: 836.6 MHz; Duty Cycle: 1:1

Medium parameters used: $\sigma = 0$ mho/m, $\epsilon_r = 1$; $\rho = 1000$ kg/m³

Phantom section: E Device Section

Measurement Standard: DASYS (IEEE/IEC)

DASY5 Configuration:

- Probe: ER3DV6 - SN2302; ConvF(1, 1, 1); Calibrated: 6/15/2010
- Sensor-Surface: (Fix Surface)
- Electronics: DAE4 Sn779; Calibrated: 1/21/2010
- Phantom: HAC Test Arch 4.6; Type: SD HAC P01 BA; Serial: 1038
- Measurement SW: DASYS, V5.0 Build 125; SEMCAD X Version 13.4 Build 125

E Scan - ER3DV6 - measurement distance from the probe sensor center to the Device = 15mm/Hearing Aid Compatibility Test (101x101x1): Measurement grid: dx=5mm, dy=5mm

Maximum value of peak Total field = 63.5 V/m

Probe Modulation Factor = 1.01

Device Reference Point: 0, 0, 353.7 mm

Reference Value = 76.7 V/m; Power Drift = 0.164 dB

Hearing Aid Near-Field Category: M4 (AWF 0 dB)

Peak E-field in V/m

Grid 1	Grid 2	Grid 3
54.1 M4	61.7 M4	60.8 M4
Grid 4	Grid 5	Grid 6
56.3 M4	63.5 M4	62.5 M4
Grid 7	Grid 8	Grid 9
58.8 M4	63.6 M4	62.6 M4

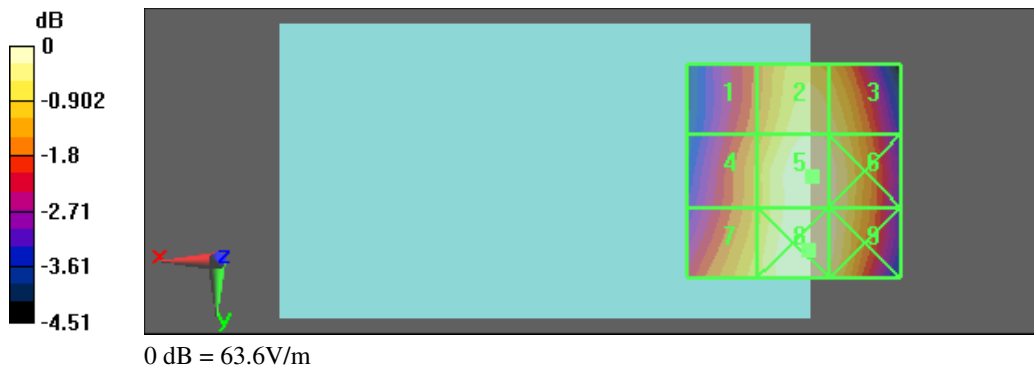



Test Laboratory: A Test Lab Techno Corp.

Date/Time: 8/26/2010 1:34:37 PM

HAC_WCDMA Band V CH4233_E

DUT: PD98120; Type: Mobile Phone; FCC ID: NM8PD98120

Communication System: WCDMA Band V; Frequency: 846.6 MHz; Duty Cycle: 1:1

Medium parameters used: $\sigma = 0$ mho/m, $\epsilon_r = 1$; $\rho = 1000$ kg/m³

Phantom section: E Device Section

Measurement Standard: DASYS (IEEE/IEC)

DASY5 Configuration:

- Probe: ER3DV6 - SN2302; ConvF(1, 1, 1); Calibrated: 6/15/2010
- Sensor-Surface: (Fix Surface)
- Electronics: DAE4 Sn779; Calibrated: 1/21/2010
- Phantom: HAC Test Arch 4.6; Type: SD HAC P01 BA; Serial: 1038
- Measurement SW: DASYS, V5.0 Build 125; SEMCAD X Version 13.4 Build 125

E Scan - ER3DV6 - measurement distance from the probe sensor center to the Device = 15mm/Hearing Aid Compatibility Test (101x101x1): Measurement grid: dx=5mm, dy=5mm

Maximum value of peak Total field = 66 V/m

Probe Modulation Factor = 1.01

Device Reference Point: 0, 0, 353.7 mm

Reference Value = 81.2 V/m; Power Drift = -0.00697 dB

Hearing Aid Near-Field Category: M4 (AWF 0 dB)

Peak E-field in V/m

Grid 1	Grid 2	Grid 3
56.5 M4	64.9 M4	63.2 M4
Grid 4	Grid 5	Grid 6
58.4 M4	66 M4	65.2 M4
Grid 7	Grid 8	Grid 9
61.3 M4	66.3 M4	65.2 M4





Test Laboratory: A Test Lab Techno Corp.

Date/Time: 8/26/2010 4:25:01 PM

HAC_GSM850 CH128_H

DUT: PD98120; Type: Mobile Phone; FCC ID: NM8PD98120

Communication System: GSM850; Frequency: 824.2 MHz; Duty Cycle: 1:8.3

Medium parameters used: $\sigma = 0$ mho/m, $\epsilon_r = 1$; $\rho = 1$ kg/m³

Phantom section: H Device Section

Measurement Standard: DASY5 (IEEE/IEC)

DASY5 Configuration:

- Probe: H3DV6 - SN6187; ; Calibrated: 6/15/2010
- Sensor-Surface: (Fix Surface)
- Electronics: DAE4 Sn779; Calibrated: 1/21/2010
- Phantom: HAC Test Arch 4.6; Type: SD HAC P01 BA; Serial: 1038
- Measurement SW: DASY5, V5.0 Build 125; SEMCAD X Version 13.4 Build 125

H Scan - H3DV6 - measurement distance from the probe sensor center to the Device = 15mm/Hearing Aid Compatibility Test (101x101x1): Measurement grid: dx=5mm, dy=5mm

Maximum value of peak Total field = 0.173 A/m

Probe Modulation Factor = 2.37

Device Reference Point: 0, 0, 353.7 mm

Reference Value = 0.052 A/m; Power Drift = 0.071 dB

Hearing Aid Near-Field Category: M4 (AWF -5 dB)

Peak H-field in A/m

Grid 1 0.245 M4	Grid 2 0.172 M4	Grid 3 0.108 M4
Grid 4 0.224 M4	Grid 5 0.159 M4	Grid 6 0.100 M4
Grid 7 0.246 M4	Grid 8 0.173 M4	Grid 9 0.112 M4





Test Laboratory: A Test Lab Techno Corp.

Date/Time: 8/26/2010 4:32:15 PM

HAC_GSM850 CH190_H

DUT: PD98120; Type: Mobile Phone; FCC ID: NM8PD98120

Communication System: GSM850; Frequency: 836.6 MHz; Duty Cycle: 1:8.3

Medium parameters used: $\sigma = 0$ mho/m, $\epsilon_r = 1$; $\rho = 1$ kg/m³

Phantom section: H Device Section

Measurement Standard: DASYS (IEEE/IEC)

DASY5 Configuration:

- Probe: H3DV6 - SN6187; ; Calibrated: 6/15/2010
- Sensor-Surface: (Fix Surface)
- Electronics: DAE4 Sn779; Calibrated: 1/21/2010
- Phantom: HAC Test Arch 4.6; Type: SD HAC P01 BA; Serial: 1038
- Measurement SW: DASYS, V5.0 Build 125; SEMCAD X Version 13.4 Build 125

H Scan - H3DV6 - measurement distance from the probe sensor center to the Device = 15mm/Hearing Aid Compatibility Test (101x101x1): Measurement grid: dx=5mm, dy=5mm

Maximum value of peak Total field = 0.189 A/m

Probe Modulation Factor = 2.57

Device Reference Point: 0, 0, 353.7 mm

Reference Value = 0.052 A/m; Power Drift = 0.080 dB

Hearing Aid Near-Field Category: M4 (AWF -5 dB)

Peak H-field in A/m

Grid 1 0.271 M4	Grid 2 0.189 M4	Grid 3 0.118 M4
Grid 4 0.246 M4	Grid 5 0.174 M4	Grid 6 0.108 M4
Grid 7 0.272 M4	Grid 8 0.189 M4	Grid 9 0.122 M4





Test Laboratory: A Test Lab Techno Corp.

Date/Time: 8/26/2010 4:38:26 PM

HAC_GSM850 CH251_H

DUT: PD98120; Type: Mobile Phone; FCC ID: NM8PD98120

Communication System: GSM850; Frequency: 848.8 MHz; Duty Cycle: 1:8.3

Medium parameters used: $\sigma = 0$ mho/m, $\epsilon_r = 1$; $\rho = 1$ kg/m³

Phantom section: H Device Section

Measurement Standard: DASYS (IEEE/IEC)

DASY5 Configuration:

- Probe: H3DV6 - SN6187; ; Calibrated: 6/15/2010
- Sensor-Surface: (Fix Surface)
- Electronics: DAE4 Sn779; Calibrated: 1/21/2010
- Phantom: HAC Test Arch 4.6; Type: SD HAC P01 BA; Serial: 1038
- Measurement SW: DASYS, V5.0 Build 125; SEMCAD X Version 13.4 Build 125

H Scan - H3DV6 - measurement distance from the probe sensor center to the Device = 15mm/Hearing Aid Compatibility Test (101x101x1): Measurement grid: dx=5mm, dy=5mm

Maximum value of peak Total field = 0.215 A/m

Probe Modulation Factor = 2.57

Device Reference Point: 0, 0, 353.7 mm

Reference Value = 0.060 A/m; Power Drift = 0.010 dB

Hearing Aid Near-Field Category: M4 (AWF -5 dB)

Peak H-field in A/m

Grid 1 0.305 M4	Grid 2 0.214 M4	Grid 3 0.134 M4
Grid 4 0.279 M4	Grid 5 0.197 M4	Grid 6 0.125 M4
Grid 7 0.307 M4	Grid 8 0.215 M4	Grid 9 0.138 M4

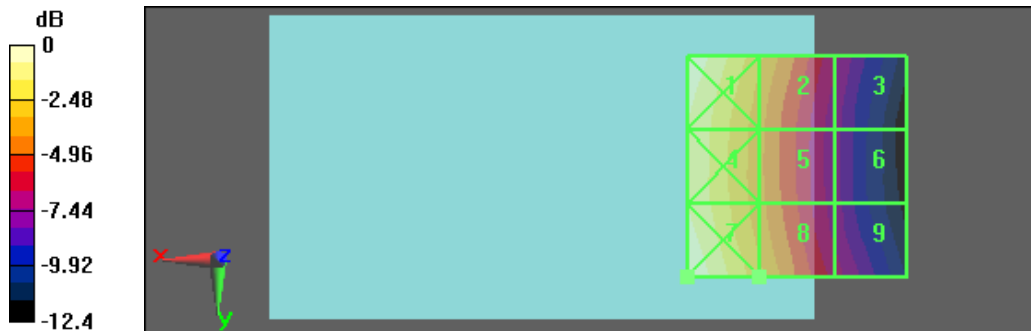

0 dB = 0.307A/m



Test Laboratory: A Test Lab Techno Corp.

Date/Time: 10/12/2010 4:25:59 PM

HAC_GSM850 CH251_H _#2 GSM Power Amplifier

DUT: PD98120; Type: Mobile Phone; FCC ID: NM8PD98120

Communication System: GSM850; Frequency: 848.8 MHz; Duty Cycle: 1:8.3

Medium parameters used: $\sigma = 0$ mho/m, $\epsilon_r = 1$; $\rho = 1$ kg/m³

Phantom section: H Device Section

Measurement Standard: DASYS (IEEE/IEC)

DASY5 Configuration:

- Probe: H3DV6 - SN6076; ; Calibrated: 8/23/2010
- Sensor-Surface: (Fix Surface)
- Electronics: DAE4 Sn779; Calibrated: 1/21/2010
- Phantom: HAC Test Arch 4.6; Type: SD HAC P01 BA; Serial: 1038
- Measurement SW: DASYS, V5.0 Build 125; SEMCAD X Version 13.4 Build 125

H Scan - H3DV6 - measurement distance from the probe sensor center to the Device = 15mm/Hearing Aid Compatibility Test (101x101x1): Measurement grid: dx=5mm, dy=5mm

Maximum value of peak Total field = 0.242 A/m

Probe Modulation Factor = 2.68

Device Reference Point: 0, 0, 353.7 mm

Reference Value = 0.067 A/m; Power Drift = -0.125 dB

Hearing Aid Near-Field Category: M4 (AWF -5 dB)

Peak H-field in A/m

Grid 1 0.346 M4	Grid 2 0.242 M4	Grid 3 0.158 M4
Grid 4 0.315 M4	Grid 5 0.224 M4	Grid 6 0.146 M4
Grid 7 0.348 M4	Grid 8 0.242 M4	Grid 9 0.148 M4

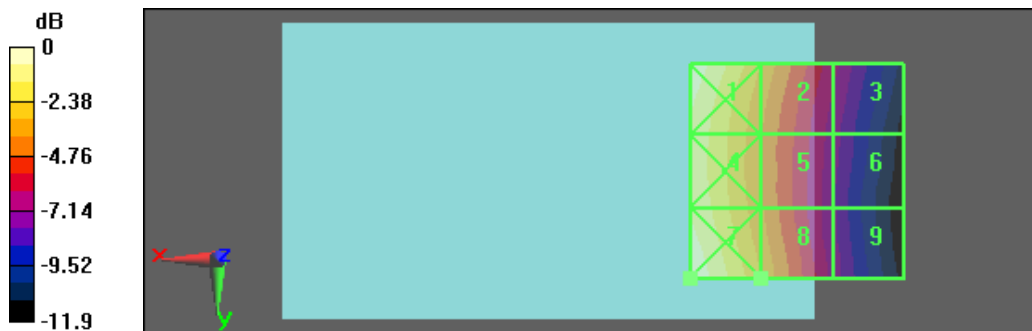

0 dB = 0.348A/m



Test Laboratory: A Test Lab Techno Corp.

Date/Time: 8/26/2010 4:45:26 PM

HAC_PCS CH512_H

DUT: PD98120; Type: Mobile Phone; FCC ID: NM8PD98120

Communication System: PCS; Frequency: 1850.2 MHz; Duty Cycle: 1:8.3

Medium parameters used: $\sigma = 0$ mho/m, $\epsilon_r = 1$; $\rho = 1$ kg/m³

Phantom section: H Device Section

Measurement Standard: DASYS (IEEE/IEC)

DASY5 Configuration:

- Probe: H3DV6 - SN6187; ; Calibrated: 6/15/2010
- Sensor-Surface: (Fix Surface)
- Electronics: DAE4 Sn779; Calibrated: 1/21/2010
- Phantom: HAC Test Arch 4.6; Type: SD HAC P01 BA; Serial: 1038
- Measurement SW: DASYS, V5.0 Build 125; SEMCAD X Version 13.4 Build 125

H Scan - H3DV6 - measurement distance from the probe sensor center to the Device = 15mm/Hearing Aid Compatibility Test (101x101x1): Measurement grid: dx=5mm, dy=5mm

Maximum value of peak Total field = 0.192 A/m

Probe Modulation Factor = 2.54

Device Reference Point: 0, 0, 353.7 mm

Reference Value = 0.083 A/m; Power Drift = 0.017 dB

Hearing Aid Near-Field Category: M3 (AWF -5 dB)

Peak H-field in A/m

Grid 1 0.196 M3	Grid 2 0.193 M3	Grid 3 0.185 M3
Grid 4 0.168 M3	Grid 5 0.192 M3	Grid 6 0.183 M3
Grid 7 0.184 M3	Grid 8 0.170 M3	Grid 9 0.164 M3

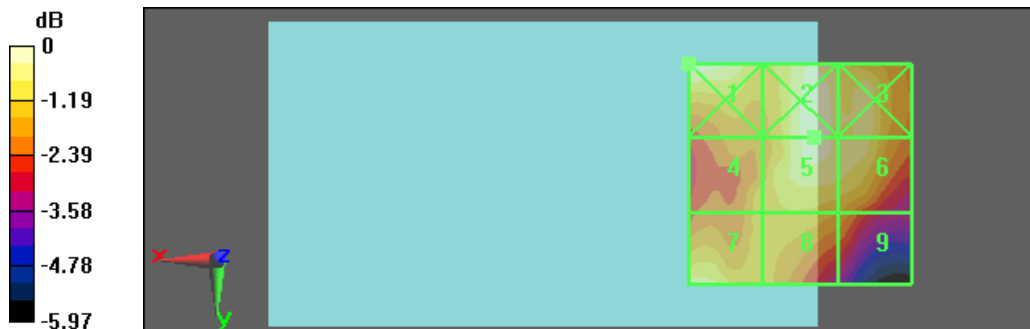

0 dB = 0.196A/m



Test Laboratory: A Test Lab Techno Corp.

Date/Time: 8/26/2010 4:52:49 PM

HAC_PCS CH661_H

DUT: PD98120; Type: Mobile Phone; FCC ID: NM8PD98120

Communication System: PCS; Frequency: 1880 MHz; Duty Cycle: 1:8.3

Medium parameters used: $\sigma = 0$ mho/m, $\epsilon_r = 1$; $\rho = 1$ kg/m³

Phantom section: H Device Section

Measurement Standard: DASYS (IEEE/IEC)

DASY5 Configuration:

- Probe: H3DV6 - SN6187; ; Calibrated: 6/15/2010
- Sensor-Surface: (Fix Surface)
- Electronics: DAE4 Sn779; Calibrated: 1/21/2010
- Phantom: HAC Test Arch 4.6; Type: SD HAC P01 BA; Serial: 1038
- Measurement SW: DASYS, V5.0 Build 125; SEMCAD X Version 13.4 Build 125

H Scan - H3DV6 - measurement distance from the probe sensor center to the Device = 15mm/Hearing Aid Compatibility Test (101x101x1): Measurement grid: dx=5mm, dy=5mm

Maximum value of peak Total field = 0.201 A/m

Probe Modulation Factor = 2.54

Device Reference Point: 0, 0, 353.7 mm

Reference Value = 0.087 A/m; Power Drift = 0.00979 dB

Hearing Aid Near-Field Category: M3 (AWF -5 dB)

Peak H-field in A/m

Grid 1 0.225 M3	Grid 2 0.202 M3	Grid 3 0.200 M3
Grid 4 0.181 M3	Grid 5 0.201 M3	Grid 6 0.200 M3
Grid 7 0.200 M3	Grid 8 0.183 M3	Grid 9 0.174 M3





Test Laboratory: A Test Lab Techno Corp.

Date/Time: 10/12/2010 4:19:25 PM

HAC_PCS CH661_H _#2 GSM Power Amplifier

DUT: PD98120; Type: Mobile Phone; FCC ID: NM8PD98120

Communication System: PCS; Frequency: 1880 MHz; Duty Cycle: 1:8.3

Medium parameters used: $\sigma = 0$ mho/m, $\epsilon_r = 1$; $\rho = 1$ kg/m³

Phantom section: H Device Section

Measurement Standard: DASYS (IEEE/IEC)

DASY5 Configuration:

- Probe: H3DV6 - SN6076; ; Calibrated: 8/23/2010
- Sensor-Surface: (Fix Surface)
- Electronics: DAE4 Sn779; Calibrated: 1/21/2010
- Phantom: HAC Test Arch 4.6; Type: SD HAC P01 BA; Serial: 1038
- Measurement SW: DASYS, V5.0 Build 125; SEMCAD X Version 13.4 Build 125

H Scan - H3DV6 - measurement distance from the probe sensor center to the Device = 15mm/Hearing Aid Compatibility Test (101x101x1): Measurement grid: dx=5mm, dy=5mm

Maximum value of peak Total field = 0.229 A/m

Probe Modulation Factor = 2.44

Device Reference Point: 0, 0, 353.7 mm

Reference Value = 0.097 A/m; Power Drift = -0.00784 dB

Hearing Aid Near-Field Category: M3 (AWF -5 dB)

Peak H-field in A/m

Grid 1 0.235 M3	Grid 2 0.230 M3	Grid 3 0.230 M3
Grid 4 0.187 M3	Grid 5 0.229 M3	Grid 6 0.229 M3
Grid 7 0.205 M3	Grid 8 0.198 M3	Grid 9 0.198 M3

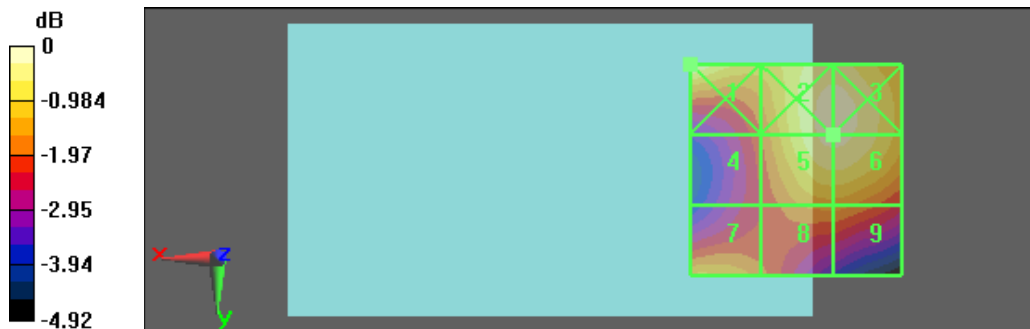

0 dB = 0.235A/m



Test Laboratory: A Test Lab Techno Corp.

Date/Time: 8/26/2010 4:59:25 PM

HAC_PCS CH810_H

DUT: PD98120; Type: Mobile Phone; FCC ID: NM8PD98120

Communication System: PCS; Frequency: 1909.8 MHz; Duty Cycle: 1:8.3

Medium parameters used: $\sigma = 0$ mho/m, $\epsilon_r = 1$; $\rho = 1$ kg/m³

Phantom section: H Device Section

Measurement Standard: DASYS (IEEE/IEC)

DASY5 Configuration:

- Probe: H3DV6 - SN6187; ; Calibrated: 6/15/2010
- Sensor-Surface: (Fix Surface)
- Electronics: DAE4 Sn779; Calibrated: 1/21/2010
- Phantom: HAC Test Arch 4.6; Type: SD HAC P01 BA; Serial: 1038
- Measurement SW: DASYS, V5.0 Build 125; SEMCAD X Version 13.4 Build 125

H Scan - H3DV6 - measurement distance from the probe sensor center to the Device = 15mm/Hearing Aid Compatibility Test (101x101x1): Measurement grid: dx=5mm, dy=5mm

Maximum value of peak Total field = 0.192 A/m

Probe Modulation Factor = 2.54

Device Reference Point: 0, 0, 353.7 mm

Reference Value = 0.082 A/m; Power Drift = -0.011 dB

Hearing Aid Near-Field Category: M3 (AWF -5 dB)

Peak H-field in A/m

Grid 1 0.219 M3	Grid 2 0.193 M3	Grid 3 0.193 M3
Grid 4 0.172 M3	Grid 5 0.192 M3	Grid 6 0.191 M3
Grid 7 0.189 M3	Grid 8 0.172 M3	Grid 9 0.163 M3

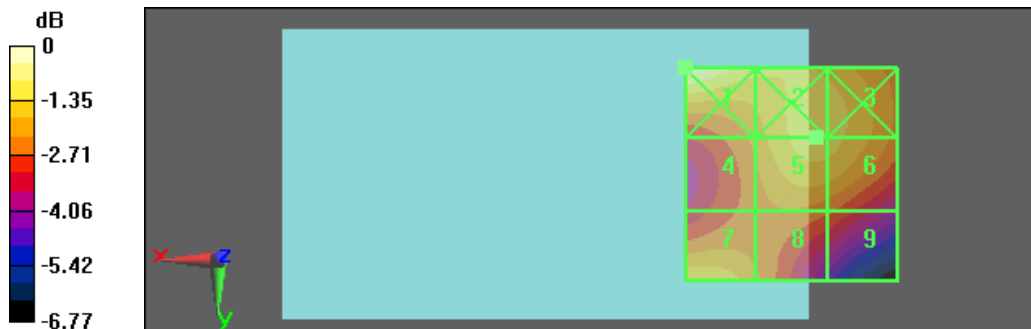

0 dB = 0.219A/m



Test Laboratory: A Test Lab Techno Corp.

Date/Time: 8/26/2010 5:35:49 PM

HAC_WCDMA Band II CH9262_H

DUT: PD98120; Type: Mobile Phone; FCC ID: NM8PD98120

Communication System: WCDMA Band II; Frequency: 1852.4 MHz; Duty Cycle: 1:1

Medium parameters used: $\sigma = 0$ mho/m, $\epsilon_r = 1$; $\rho = 1$ kg/m³

Phantom section: H Device Section

Measurement Standard: DASYS (IEEE/IEC)

DASY5 Configuration:

- Probe: H3DV6 - SN6187; ; Calibrated: 6/15/2010
- Sensor-Surface: (Fix Surface)
- Electronics: DAE4 Sn779; Calibrated: 1/21/2010
- Phantom: HAC Test Arch 4.6; Type: SD HAC P01 BA; Serial: 1038
- Measurement SW: DASYS, V5.0 Build 125; SEMCAD X Version 13.4 Build 125

H Scan - H3DV6 - measurement distance from the probe sensor center to the Device = 15mm/Hearing Aid Compatibility Test (101x101x1): Measurement grid: dx=5mm, dy=5mm

Maximum value of peak Total field = 0.101 A/m

Probe Modulation Factor = 0.810

Device Reference Point: 0, 0, 353.7 mm

Reference Value = 0.137 A/m; Power Drift = -0.070 dB

Hearing Aid Near-Field Category: M4 (AWF 0 dB)

Peak H-field in A/m

Grid 1 0.103 M4	Grid 2 0.101 M4	Grid 3 0.100 M4
Grid 4 0.090 M4	Grid 5 0.101 M4	Grid 6 0.100 M4
Grid 7 0.097 M4	Grid 8 0.090 M4	Grid 9 0.087 M4





Test Laboratory: A Test Lab Techno Corp.

Date/Time: 8/26/2010 5:42:44 PM

HAC_WCDMA Band II CH9400_H

DUT: PD98120; Type: Mobile Phone; FCC ID: NM8PD98120

Communication System: WCDMA Band II; Frequency: 1880 MHz; Duty Cycle: 1:1

Medium parameters used: $\sigma = 0$ mho/m, $\epsilon_r = 1$; $\rho = 1$ kg/m³

Phantom section: H Device Section

Measurement Standard: DASY5 (IEEE/IEC)

DASY5 Configuration:

- Probe: H3DV6 - SN6187; ; Calibrated: 6/15/2010
- Sensor-Surface: (Fix Surface)
- Electronics: DAE4 Sn779; Calibrated: 1/21/2010
- Phantom: HAC Test Arch 4.6; Type: SD HAC P01 BA; Serial: 1038
- Measurement SW: DASY5, V5.0 Build 125; SEMCAD X Version 13.4 Build 125

H Scan - H3DV6 - measurement distance from the probe sensor center to the Device = 15mm/Hearing Aid Compatibility Test (101x101x1): Measurement grid: dx=5mm, dy=5mm

Maximum value of peak Total field = 0.099 A/m

Probe Modulation Factor = 0.810

Device Reference Point: 0, 0, 353.7 mm

Reference Value = 0.133 A/m; Power Drift = -0.000285 dB

Hearing Aid Near-Field Category: M4 (AWF 0 dB)

Peak H-field in A/m

Grid 1 0.108 M4	Grid 2 0.100 M4	Grid 3 0.100 M4
Grid 4 0.089 M4	Grid 5 0.099 M4	Grid 6 0.099 M4
Grid 7 0.096 M4	Grid 8 0.089 M4	Grid 9 0.086 M4

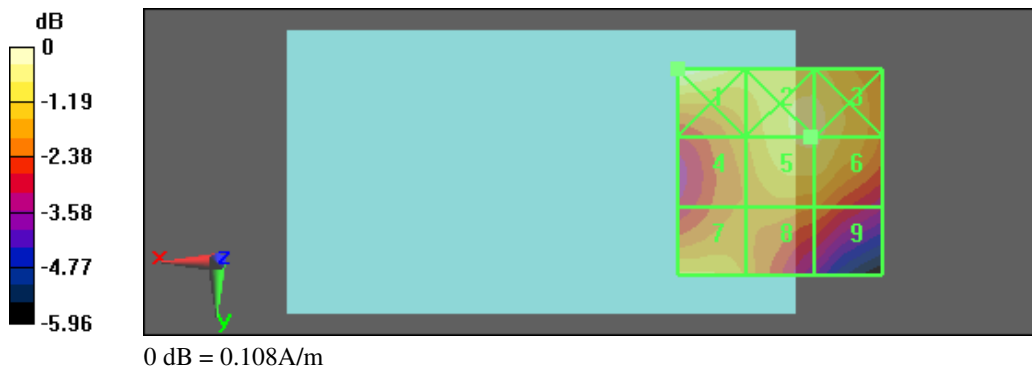



Test Laboratory: A Test Lab Techno Corp.

Date/Time: 8/26/2010 5:48:51 PM

HAC_WCDMA Band II CH9538_H

DUT: PD98120; Type: Mobile Phone; FCC ID: NM8PD98120

Communication System: WCDMA Band II; Frequency: 1907.6 MHz; Duty Cycle: 1:1

Medium parameters used: $\sigma = 0$ mho/m, $\epsilon_r = 1$; $\rho = 1$ kg/m³

Phantom section: H Device Section

Measurement Standard: DASYS (IEEE/IEC)

DASY5 Configuration:

- Probe: H3DV6 - SN6187; ; Calibrated: 6/15/2010
- Sensor-Surface: (Fix Surface)
- Electronics: DAE4 Sn779; Calibrated: 1/21/2010
- Phantom: HAC Test Arch 4.6; Type: SD HAC P01 BA; Serial: 1038
- Measurement SW: DASYS, V5.0 Build 125; SEMCAD X Version 13.4 Build 125

H Scan - H3DV6 - measurement distance from the probe sensor center to the Device = 15mm/Hearing Aid Compatibility Test (101x101x1): Measurement grid: dx=5mm, dy=5mm

Maximum value of peak Total field = 0.092 A/m

Probe Modulation Factor = 0.810

Device Reference Point: 0, 0, 353.7 mm

Reference Value = 0.121 A/m; Power Drift = 0.128 dB

Hearing Aid Near-Field Category: M4 (AWF 0 dB)

Peak H-field in A/m

Grid 1 0.103 M4	Grid 2 0.093 M4	Grid 3 0.092 M4
Grid 4 0.083 M4	Grid 5 0.092 M4	Grid 6 0.092 M4
Grid 7 0.088 M4	Grid 8 0.081 M4	Grid 9 0.079 M4





Test Laboratory: A Test Lab Techno Corp.

Date/Time: 8/26/2010 5:12:57 PM

HAC_WCDMA Band V CH4132_H

DUT: PD98120; Type: Mobile Phone; FCC ID: NM8PD98120

Communication System: WCDMA Band V; Frequency: 826.4 MHz;Duty Cycle: 1:1

Medium parameters used: $\sigma = 0$ mho/m, $\epsilon_r = 1$; $\rho = 1$ kg/m³

Phantom section: H Device Section

Measurement Standard: DASYS (IEEE/IEC)

DASY5 Configuration:

- Probe: H3DV6 - SN6187; ; Calibrated: 6/15/2010
- Sensor-Surface: (Fix Surface)
- Electronics: DAE4 Sn779; Calibrated: 1/21/2010
- Phantom: HAC Test Arch 4.6; Type: SD HAC P01 BA; Serial: 1038
- Measurement SW: DASYS, V5.0 Build 125;SEMCAD X Version 13.4 Build 125

H Scan - H3DV6 - measurement distance from the probe sensor center to the Device = 15mm/Hearing Aid Compatibility Test (101x101x1): Measurement grid: dx=5mm, dy=5mm

Maximum value of peak Total field = 0.070 A/m

Probe Modulation Factor = 0.860

Device Reference Point: 0, 0, 353.7 mm

Reference Value = 0.059 A/m; Power Drift = -0.066 dB

Hearing Aid Near-Field Category: M4 (AWF 0 dB)

Peak H-field in A/m

Grid 1 0.099 M4	Grid 2 0.069 M4	Grid 3 0.043 M4
Grid 4 0.090 M4	Grid 5 0.064 M4	Grid 6 0.040 M4
Grid 7 0.099 M4	Grid 8 0.070 M4	Grid 9 0.045 M4

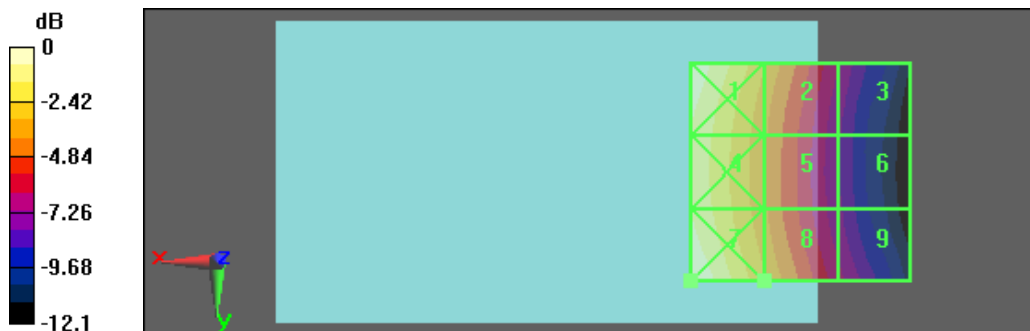

0 dB = 0.099A/m



Test Laboratory: A Test Lab Techno Corp.

Date/Time: 8/26/2010 5:20:41 PM

HAC_WCDMA Band V CH4183_H

DUT: PD98120; Type: Mobile Phone; FCC ID: NM8PD98120

Communication System: WCDMA Band V; Frequency: 836.6 MHz; Duty Cycle: 1:1

Medium parameters used: $\sigma = 0$ mho/m, $\epsilon_r = 1$; $\rho = 1$ kg/m³

Phantom section: H Device Section

Measurement Standard: DASYS (IEEE/IEC)

DASY5 Configuration:

- Probe: H3DV6 - SN6187; ; Calibrated: 6/15/2010
- Sensor-Surface: (Fix Surface)
- Electronics: DAE4 Sn779; Calibrated: 1/21/2010
- Phantom: HAC Test Arch 4.6; Type: SD HAC P01 BA; Serial: 1038
- Measurement SW: DASYS, V5.0 Build 125; SEMCAD X Version 13.4 Build 125

H Scan - H3DV6 - measurement distance from the probe sensor center to the Device = 15mm/Hearing Aid Compatibility Test (101x101x1): Measurement grid: dx=5mm, dy=5mm

Maximum value of peak Total field = 0.078 A/m

Probe Modulation Factor = 0.860

Device Reference Point: 0, 0, 353.7 mm

Reference Value = 0.064 A/m; Power Drift = 0.149 dB

Hearing Aid Near-Field Category: M4 (AWF 0 dB)

Peak H-field in A/m

Grid 1 0.111 M4	Grid 2 0.077 M4	Grid 3 0.049 M4
Grid 4 0.101 M4	Grid 5 0.072 M4	Grid 6 0.045 M4
Grid 7 0.111 M4	Grid 8 0.078 M4	Grid 9 0.050 M4

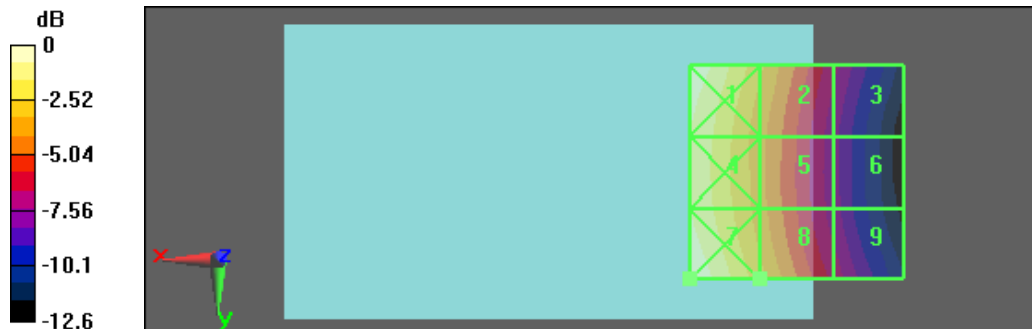



Test Laboratory: A Test Lab Techno Corp.

Date/Time: 8/26/2010 5:26:56 PM

HAC_WCDMA Band V CH4233_H

DUT: PD98120; Type: Mobile Phone; FCC ID: NM8PD98120

Communication System: WCDMA Band V; Frequency: 846.6 MHz;Duty Cycle: 1:1

Medium parameters used: $\sigma = 0$ mho/m, $\epsilon_r = 1$; $\rho = 1$ kg/m³

Phantom section: H Device Section

Measurement Standard: DASYS (IEEE/IEC)

DASY5 Configuration:

- Probe: H3DV6 - SN6187; ; Calibrated: 6/15/2010
- Sensor-Surface: (Fix Surface)
- Electronics: DAE4 Sn779; Calibrated: 1/21/2010
- Phantom: HAC Test Arch 4.6; Type: SD HAC P01 BA; Serial: 1038
- Measurement SW: DASYS, V5.0 Build 125;SEMCAD X Version 13.4 Build 125

H Scan - H3DV6 - measurement distance from the probe sensor center to the Device = 15mm/Hearing Aid Compatibility Test (101x101x1): Measurement grid: dx=5mm, dy=5mm

Maximum value of peak Total field = 0.083 A/m

Probe Modulation Factor = 0.860

Device Reference Point: 0, 0, 353.7 mm

Reference Value = 0.069 A/m; Power Drift = 0.031 dB

Hearing Aid Near-Field Category: M4 (AWF 0 dB)

Peak H-field in A/m

Grid 1 0.116 M4	Grid 2 0.082 M4	Grid 3 0.052 M4
Grid 4 0.106 M4	Grid 5 0.076 M4	Grid 6 0.048 M4
Grid 7 0.117 M4	Grid 8 0.083 M4	Grid 9 0.054 M4





Appendix D - Calibration

All of the instruments Calibration information are listed below.

- Dipole _ CD835V3 SN:1017 Calibration No.CD835V3-1017_Jul10
- Dipole _ CD1880V3 SN:1036 Calibration No.CD1880V3-1036_Jul10
- Probe _ ER3DV6 SN: 2302 Calibration No. ER3-2302_Jun10
- Probe _ H3DV6 SN: 6187 Calibration No. H3-6187_Jun10
- DAE _ DAE4 SN:779 Calibration No.DAE4-779_ Jan10



Calibration Laboratory of
 Schmid & Partner
 Engineering AG
 Zeughausstrasse 43, 8004 Zurich, Switzerland



S Schweizerischer Kalibrierdienst
S Service suisse d'étalonnage
C Servizio svizzero di taratura
S Swiss Calibration Service

Accredited by the Swiss Accreditation Service (SAS)
 The Swiss Accreditation Service is one of the signatories to the EA
 Multilateral Agreement for the recognition of calibration certificates

Accreditation No.: **SCS 108**

Client **ATL (Auden)**

Certificate No: **CD835V3-1017_Jul10**

CALIBRATION CERTIFICATE

Object **CD835V3 - SN: 1017**

Calibration procedure(s) **QA CAL-20.v5
 Calibration procedure for dipoles in air**

Calibration date: **July 13, 2010**

This calibration certificate documents the traceability to national standards, which realize the physical units of measurements (SI).
 All calibrations have been conducted in the closed laboratory facility: environment temperature (22 ± 3)°C and humidity < 70%.

Calibration Equipment used (M&TE critical for calibration)

Primary Standards	ID #	Cal Date (Certificate No.)	Scheduled Calibration
Power meter EPM-442A	GB37480704	06-Oct-09 (No. 217-01086)	Oct-10
Power sensor HP 8481A	US37292783	06-Oct-09 (No. 217-01086)	Oct-10
Probe ER3DV6	SN: 2336	30-Dec-09 (No. ER3-2336_Dec09)	Dec-10
Probe H3DV6	SN: 6065	30-Dec-09 (No. H3-6065_Dec09)	Dec-10
DAE4	SN: 781	22-Jan-10 (No. DAE4-781_Jan10)	Jan-11
Secondary Standards	ID #	Check Date (in house)	Scheduled Check
Power meter Agilent 4419B	SN: GB42420191	09-Oct-09 (in house check Oct-09)	In house check: Oct-10
Power sensor HP 8482H	SN: 3318A09450	09-Oct-09 (in house check Oct-09)	In house check: Oct-10
Power sensor HP 8482A	SN: US37295597	09-Oct-09 (in house check Oct-09)	In house check: Oct-10
Network Analyzer HP 8753E	US37390585	18-Oct-01 (in house check Oct-09)	In house check: Oct-10
RF generator E4433B	MY 41000675	03-Nov-04 (in house check Oct-09)	In house check: Oct-11

	Name	Function	Signature
Calibrated by:	Mike Meili	Laboratory Technician	
Approved by:	Fin Bomholt	Technical Director	

Issued: July 15, 2010

This calibration certificate shall not be reproduced except in full without written approval of the laboratory.

Calibration Laboratory of

Schmid & Partner

Engineering AG

Zeughausstrasse 43, 8004 Zurich, Switzerland



S Schweizerischer Kalibrierdienst
 C Service suisse d'étalonnage
 S Servizio svizzero di taratura
 S Swiss Calibration Service

Accredited by the Swiss Accreditation Service (SAS)

The Swiss Accreditation Service is one of the signatories to the EA

Multilateral Agreement for the recognition of calibration certificates

Accreditation No.: **SCS 108**

References

- [1] ANSI-C63.19-2006
 American National Standard for Methods of Measurement of Compatibility between Wireless Communications Devices and Hearing Aids.
- [2] ANSI-C63.19-2007
 American National Standard for Methods of Measurement of Compatibility between Wireless Communications Devices and Hearing Aids.

Methods Applied and Interpretation of Parameters:

- *Coordinate System:* y-axis is in the direction of the dipole arms. z-axis is from the basis of the antenna (mounted on the table) towards its feed point between the two dipole arms. x-axis is normal to the other axes. In coincidence with the standards [1, 2], the measurement planes (probe sensor center) are selected to be at a distance of 10 mm above the top edge of the dipole arms.
- *Measurement Conditions:* Further details are available from the hardcopies at the end of the certificate. All figures stated in the certificate are valid at the frequency indicated. The forward power to the dipole connector is set with a calibrated power meter connected and monitored with an auxiliary power meter connected to a directional coupler. While the dipole under test is connected, the forward power is adjusted to the same level.
- *Antenna Positioning:* The dipole is mounted on a HAC Test Arch phantom using the matching dipole positioner with the arms horizontal and the feeding cable coming from the floor. The measurements are performed in a shielded room with absorbers around the setup to reduce the reflections. It is verified before the mounting of the dipole under the Test Arch phantom, that its arms are perfectly in a line. It is installed on the HAC dipole positioner with its arms parallel below the dielectric reference wire and able to move elastically in vertical direction without changing its relative position to the top center of the Test Arch phantom. The vertical distance to the probe is adjusted after dipole mounting with a DASY5 Surface Check job. Before the measurement, the distance between phantom surface and probe tip is verified. The proper measurement distance is selected by choosing the matching section of the HAC Test Arch phantom with the proper device reference point (upper surface of the dipole) and the matching grid reference point (tip of the probe) considering the probe sensor offset. The vertical distance to the probe is essential for the accuracy.
- *Feed Point Impedance and Return Loss:* These parameters are measured using a HP 8753E Vector Network Analyzer. The impedance is specified at the SMA connector of the dipole. The influence of reflections was eliminated by applying the averaging function while moving the dipole in the air, at least 70cm away from any obstacles.
- *E-field distribution:* E field is measured in the x-y-plane with an isotropic ER3D-field probe with 100 mW forward power to the antenna feed point. In accordance with [1, 2], the scan area is 20mm wide, its length exceeds the dipole arm length (180 or 90mm). The sensor center is 10 mm (in z) above the top of the dipole arms. Two 3D maxima are available near the end of the dipole arms. Assuming the dipole arms are perfectly in one line, the average of these two maxima (in subgrid 2 and subgrid 8) is determined to compensate for any non-parallelity to the measurement plane as well as the sensor displacement. The E-field value stated as calibration value represents the maximum of the interpolated 3D-E-field, 10mm above the dipole surface.
- *H-field distribution:* H-field is measured with an isotropic H-field probe with 100mW forward power to the antenna feed point, in the x-y-plane. The scan area and sensor distance is equivalent to the E-field scan. The maximum of the field is available at the center (subgrid 5) above the feed point. The H-field value stated as calibration value represents the maximum of the interpolated H-field, 10mm above the dipole surface at the feed point.



1 Measurement Conditions

DASY system configuration, as far as not given on page 1.

DASY Version	DASY5	V52.2 B0
DASY PP Version	SEMCAD X	V14.2 B2
Phantom	HAC Test Arch	SD HAC P01 BA, #1070
Distance Dipole Top - Probe Center	10 mm	
Scan resolution	dx, dy = 5 mm	area = 20 x 180 mm
Frequency	835 MHz ± 1 MHz	
Forward power at dipole connector	20.0 dBm = 100mW	
Input power drift	< 0.05 dB	

2 Maximum Field values

H-field 10 mm above dipole surface	condition	interpolated maximum
Maximum measured	100 mW forward power	0.457 A/m

Uncertainty for H-field measurement: 8.2% (k=2)

E-field 10 mm above dipole surface	condition	Interpolated maximum
Maximum measured above high end-	100 mW forward power	168.6 V/m
Maximum measured above low end	100 mW forward power	155.7 V/m
Averaged maximum above arm	100 mW forward power	162.2 V/m

Uncertainty for E-field measurement: 12.8% (k=2)

3 Appendix

3.1 Antenna Parameters

Frequency	Return Loss	Impedance
800 MHz	16.2 dB	(42.3 – j12.1) Ohm
835 MHz	28.6 dB	(50.2 + j3.7) Ohm
900 MHz	17.7 dB	(56.1 – j12.6) Ohm
950 MHz	20.8 dB	(45.5 + j7.5) Ohm
960 MHz	15.5 dB	(51.3 + j17.2) Ohm

3.2 Antenna Design and Handling

The calibration dipole has a symmetric geometry with a built-in two stub matching network, which leads to the enhanced bandwidth.

The dipole is built of standard semirigid coaxial cable. The internal matching line is open ended. The antenna is therefore open for DC signals.

Do not apply force to dipole arms, as they are liable to bend. The soldered connections near the feedpoint may be damaged. After excessive mechanical stress or overheating, check the impedance characteristics to ensure that the internal matching network is not affected.

After long term use with 40W radiated power, only a slight warming of the dipole near the feedpoint can be measured.



3.3 Measurement Sheets

3.3.1 Return Loss and Smith Chart

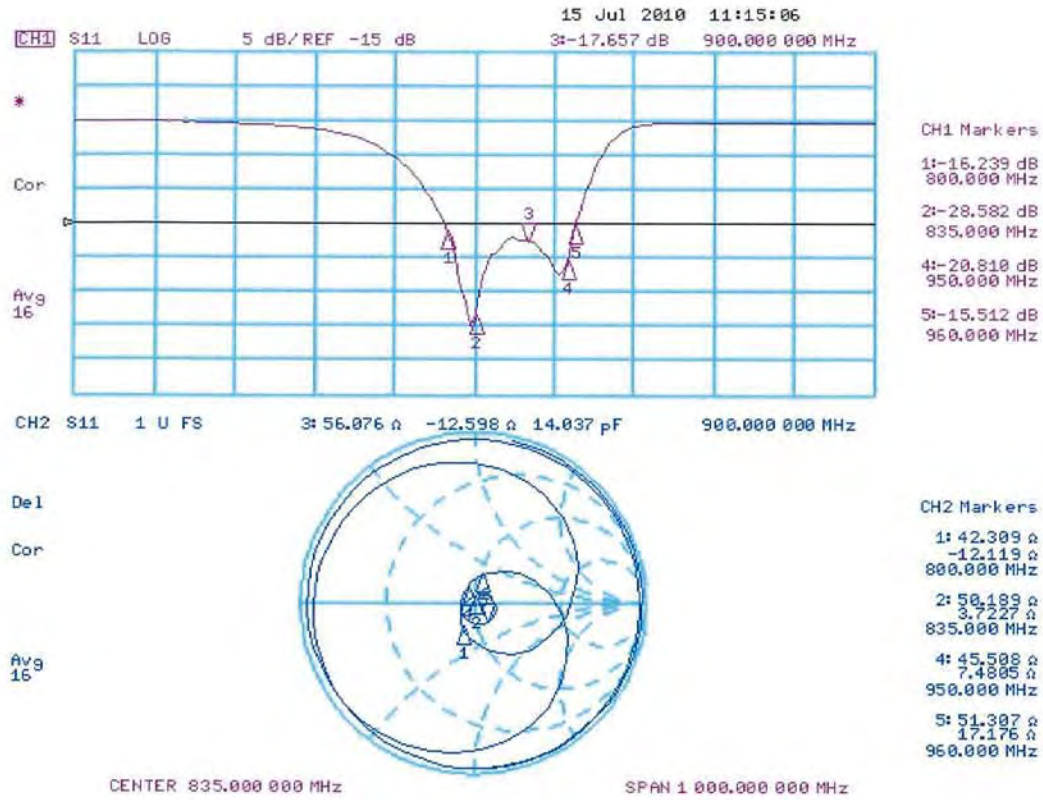

3.3.2 DASY4 H-field Result

Date/Time: 13.07.2010 18:17:07

Test Laboratory: SPEAG Lab2

DUT: HAC-Dipole 835 MHz; Type: CD835V3; Serial: 1017

Communication System: CW; Communication System Band: CD835 (835.0 MHz); Frequency: 835 MHz; Communication System PAR: 0 dB

Medium parameters used: $\sigma = 0$ mho/m, $\epsilon_r = 1$; $\rho = 1$ kg/m³

Phantom section: RF Section

Measurement Standard: DASY5 (IEEE/IEC/ANSI C63.19-2007)

DASY5 Configuration:

- Probe: H3DV6 - SN6065; ; Calibrated: 30.12.2009
- Sensor-Surface: (Fix Surface)
- Electronics: DAE4 Sn781; Calibrated: 22.01.2010
- Phantom: HAC Test Arch with AMCC; Type: SD HAC P01 BA; Serial: 1070
- Measurement SW: DASY52, V52.2 Build 0; Postprocessing SW: SEMCAD X, V14.2 Build 2Version 14.2.2 (1685)

Dipole H-Field measurement @ 835MHz/H Scan - measurement distance from the probe sensor center to CD835 Dipole = 10mm/Hearing Aid Compatibility Test (41x361x1):

Measurement grid: dx=5mm, dy=5mm

Maximum value of peak Total field = 0.457 A/m

Probe Modulation Factor = 1

Device Reference Point: 0, 0, -6.3 mm

Reference Value = 0.486 A/m; Power Drift = -9.15e-005 dB

Hearing Aid Near-Field Category: M4 (AWF 0 dB)

Peak H-field in A/m

Grid 1 0.381 M4	Grid 2 0.397 M4	Grid 3 0.373 M4
Grid 4 0.431 M4	Grid 5 0.457 M4	Grid 6 0.435 M4
Grid 7 0.377 M4	Grid 8 0.403 M4	Grid 9 0.387 M4

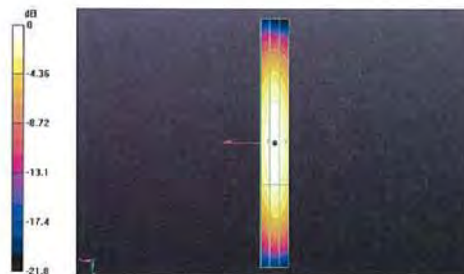

0 dB = 0.457A/m

3.3.3 DASY4 E-field Result

Date/Time: 13.07.2010 12:42:14

Test Laboratory: SPEAG Lab2

DUT: HAC-Dipole 835 MHz; Type: CD835V3; Serial: 1017

Communication System: CW; Communication System Band: CD835 (835.0 MHz); Frequency: 835 MHz; Communication System PAR: 0 dB

Medium parameters used: $\sigma = 0$ mho/m, $\epsilon_r = 1$; $\rho = 1000$ kg/m³

Phantom section: RF Section

Measurement Standard: DASY5 (IEEE/IEC/ANSI C63.19-2007)

DASY5 Configuration:

- Probe: ER3DV6 - SN2336; ConvF(1, 1, 1); Calibrated: 30.12.2009
- Sensor-Surface: (Fix Surface)
- Electronics: DAE4 Sn781; Calibrated: 22.01.2010
- Phantom: HAC Test Arch with AMCC; Type: SD HAC P01 BA; Serial: 1070
- Measurement SW: DASY52, V52.2 Build 0; Postprocessing SW: SEMCAD X, V14.2 Build 2Version 14.2.2 (1685)

Dipole E-Field measurement @ 835MHz/E Scan - measurement distance from the probe sensor center to CD835 Dipole = 10mm/Hearing Aid Compatibility Test

(41x361x1): Measurement grid: dx=5mm, dy=5mm

Maximum value of peak Total field = 168.6 V/m

Probe Modulation Factor = 1

Device Reference Point: 0, 0, -6.3 mm

Reference Value = 106.1 V/m; Power Drift = -0.050 dB

Hearing Aid Near-Field Category: M4 (AWF 0 dB)

Peak E-field in V/m

Grid 1 154.5 M4	Grid 2 155.7 M4	Grid 3 147.4 M4
Grid 4 87.8 M4	Grid 5 89.1 M4	Grid 6 85.4 M4
Grid 7 157.6 M4	Grid 8 168.6 M4	Grid 9 166.9 M4

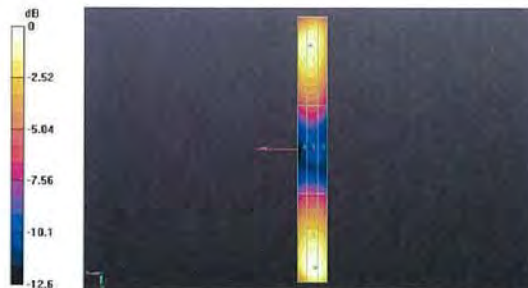

0 dB = 168.6V/m



Calibration Laboratory of
 Schmid & Partner
 Engineering AG
 Zeughausstrasse 43, 8004 Zurich, Switzerland



S Schweizerischer Kalibrierdienst
S Service suisse d'étalonnage
C Servizio svizzero di taratura
S Swiss Calibration Service

Accredited by the Swiss Accreditation Service (SAS)
 The Swiss Accreditation Service is one of the signatories to the EA
 Multilateral Agreement for the recognition of calibration certificates

Accreditation No.: **SCS 108**

Client **ATL (Auden)**

Certificate No: **CD1880V3-1036_Jul10**

CALIBRATION CERTIFICATE

Object **CD1880V3 - SN: 1036**

Calibration procedure(s) **QA CAL-20.v5
 Calibration procedure for dipoles in air**

Calibration date: **July 13, 2010**

This calibration certificate documents the traceability to national standards, which realize the physical units of measurements (SI).
 All calibrations have been conducted in the closed laboratory facility: environment temperature (22 ± 3)°C and humidity < 70%.

Calibration Equipment used (M&TE critical for calibration)

Primary Standards	ID #	Cal Date (Certificate No.)	Scheduled Calibration
Power meter EPM-442A	GB37480704	06-Oct-09 (No. 217-01086)	Oct-10
Power sensor HP 8481A	US37292783	06-Oct-09 (No. 217-01086)	Oct-10
Probe ER3DV6	SN: 2336	30-Dec-09 (No. ER3-2336_Dec09)	Dec-10
Probe H3DV6	SN: 6065	30-Dec-09 (No. H3-6065_Dec09)	Dec-10
DAE4	SN: 781	22-Jan-10 (No. DAE4-781_Jan10)	Jan-11

Secondary Standards	ID #	Check Date (in house)	Scheduled Check
Power meter Agilent 4419B	SN: GB42420191	09-Oct-09 (in house check Oct-09)	In house check: Oct-10
Power sensor HP 8482H	SN: 3318A09450	09-Oct-09 (in house check Oct-09)	In house check: Oct-10
Power sensor HP 8482A	SN: US37295597	09-Oct-09 (in house check Oct-09)	In house check: Oct-10
Network Analyzer HP 8753E	US37390585	18-Oct-01 (in house check Oct-09)	In house check: Oct-10
RF generator E4433B	MY 41000675	03-Nov-04 (in house check Oct-09)	In house check: Oct-11

	Name	Function	Signature
Calibrated by:	Mike Meili	Laboratory Technician	
Approved by:	Fin Bornholt	Technical Director	

Issued: July 15, 2010

This calibration certificate shall not be reproduced except in full without written approval of the laboratory.

Calibration Laboratory of
Schmid & Partner
Engineering AG
Zeughausstrasse 43, 8004 Zurich, Switzerland



S Schweizerischer Kalibrierdienst
S Service suisse d'étalonnage
C Servizio svizzero di taratura
S Swiss Calibration Service

Accredited by the Swiss Accreditation Service (SAS)
The Swiss Accreditation Service is one of the signatories to the EA
Multilateral Agreement for the recognition of calibration certificates

Accreditation No.: **SCS 108**

References

- [1] ANSI-C63.19-2007
American National Standard for Methods of Measurement of Compatibility between Wireless Communications Devices and Hearing Aids.

Methods Applied and Interpretation of Parameters:

- **Coordinate System:** y-axis is in the direction of the dipole arms. z-axis is from the basis of the antenna (mounted on the table) towards its feed point between the two dipole arms. x-axis is normal to the other axes. In coincidence with the standards [1], the measurement planes (probe sensor center) are selected to be at a distance of 10 mm above the top edge of the dipole arms.
- **Measurement Conditions:** Further details are available from the hardcopies at the end of the certificate. All figures stated in the certificate are valid at the frequency indicated. The forward power to the dipole connector is set with a calibrated power meter connected and monitored with an auxiliary power meter connected to a directional coupler. While the dipole under test is connected, the forward power is adjusted to the same level.
- **Antenna Positioning:** The dipole is mounted on a HAC Test Arch phantom using the matching dipole positioner with the arms horizontal and the feeding cable coming from the floor. The measurements are performed in a shielded room with absorbers around the setup to reduce the reflections. It is verified before the mounting of the dipole under the Test Arch phantom, that its arms are perfectly in a line. It is installed on the HAC dipole positioner with its arms parallel below the dielectric reference wire and able to move elastically in vertical direction without changing its relative position to the top center of the Test Arch phantom. The vertical distance to the probe is adjusted after dipole mounting with a DASY5 Surface Check job. Before the measurement, the distance between phantom surface and probe tip is verified. The proper measurement distance is selected by choosing the matching section of the HAC Test Arch phantom with the proper device reference point (upper surface of the dipole) and the matching grid reference point (tip of the probe) considering the probe sensor offset. The vertical distance to the probe is essential for the accuracy.
- **Feed Point Impedance and Return Loss:** These parameters are measured using a HP 8753E Vector Network Analyzer. The impedance is specified at the SMA connector of the dipole. The influence of reflections was eliminated by applying the averaging function while moving the dipole in the air, at least 70cm away from any obstacles.
- **E-field distribution:** E field is measured in the x-y-plane with an isotropic ER3D-field probe with 100 mW forward power to the antenna feed point. In accordance with [1], the scan area is 20mm wide, its length exceeds the dipole arm length (180 or 90mm). The sensor center is 10 mm (in z) above the top of the dipole arms. Two 3D maxima are available near the end of the dipole arms. Assuming the dipole arms are perfectly in one line, the average of these two maxima (in subgrid 2 and subgrid 8) is determined to compensate for any non-parallelity to the measurement plane as well as the sensor displacement. The E-field value stated as calibration value represents the maximum of the interpolated 3D-E-field, 10mm above the dipole surface.
- **H-field distribution:** H-field is measured with an isotropic H-field probe with 100mW forward power to the antenna feed point, in the x-y-plane. The scan area and sensor distance is equivalent to the E-field scan. The maximum of the field is available at the center (subgrid 5) above the feed point. The H-field value stated as calibration value represents the maximum of the interpolated H-field, 10mm above the dipole surface at the feed point.



1. Measurement Conditions

DASY system configuration, as far as not given on page 1.

DASY Version	DASY5	V52.2 B0
DASY PP Version	SEMCAD X	V14.2 B2
Phantom	HAC Test Arch	SD HAC P01 BA, #1070
Distance Dipole Top - Probe Center	10 mm	
Scan resolution	dx, dy = 5 mm	area = 20 x 90 mm
Frequency	1880 MHz ± 1 MHz	
Forward power at dipole connector	20.0 dBm = 100mW	
Input power drift	< 0.05 dB	

2. Maximum Field values

H-field 10 mm above dipole surface	condition	Interpolated maximum
Maximum measured	100 mW forward power	0.468 A/m

Uncertainty for H-field measurement: 8.2% (k=2)

E-field 10 mm above dipole surface	condition	Interpolated maximum
Maximum measured above high end	100 mW forward power	139.2 V/m
Maximum measured above low end	100 mW forward power	136.7 V/m
Averaged maximum above arm	100 mW forward power	138.0 V/m

Uncertainty for E-field measurement: 12.8% (k=2)

3. Appendix

3.1 Antenna Parameters

Frequency	Return Loss	Impedance
1710 MHz	19.6 dB	(50.2 + j10.6) Ohm
1880 MHz	22.4 dB	(52.1 + j7.5) Ohm
1900 MHz	22.8 dB	(54.1 + j6.3) Ohm
1950 MHz	31.1 dB	(52.7 - j1.0) Ohm
2000 MHz	20.2 dB	(41.3 + j2.0) Ohm

3.2 Antenna Design and Handling

The calibration dipole has a symmetric geometry with a built-in two stub matching network, which leads to the enhanced bandwidth.

The dipole is built of standard semirigid coaxial cable. The internal matching line is open ended. The antenna is therefore open for DC signals.

Do not apply force to dipole arms, as they are liable to bend. The soldered connections near the feedpoint may be damaged. After excessive mechanical stress or overheating, check the impedance characteristics to ensure that the internal matching network is not affected.

After long term use with 40W radiated power, only a slight warming of the dipole near the feedpoint can be measured.



3.3 Measurement Sheets

3.3.1 Return Loss and Smith Chart

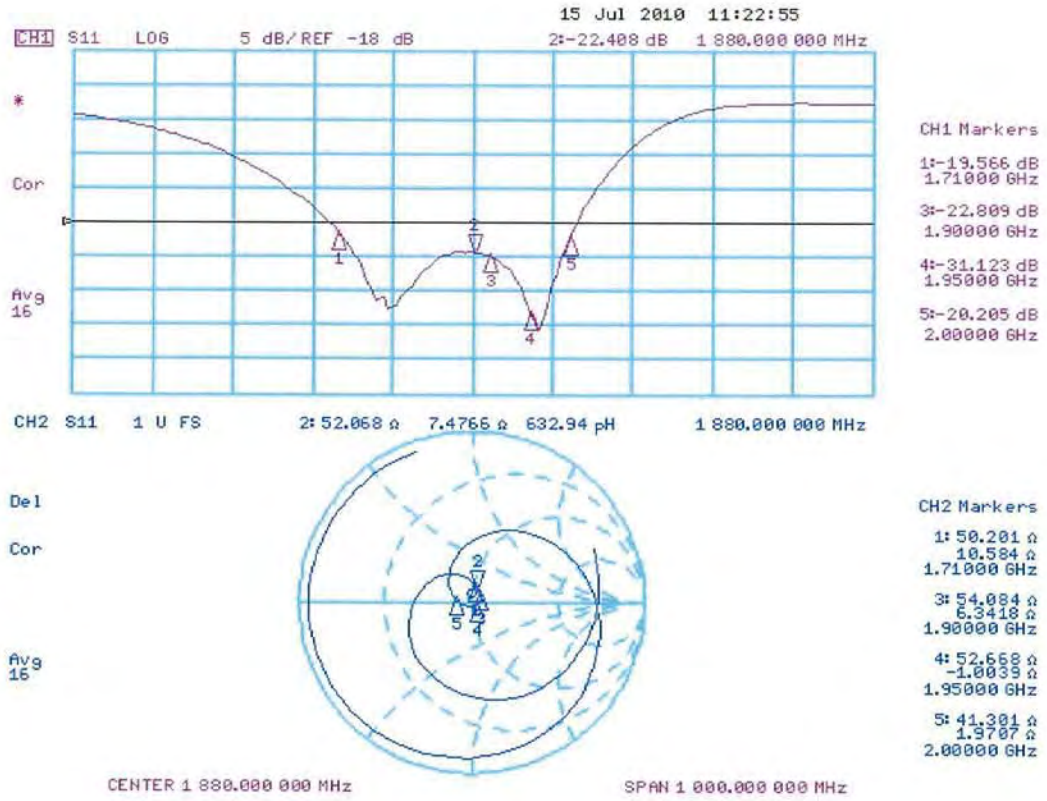

3.3.2 DASY4 H-Field Result

Date/Time: 13.07.2010 17:49:33

Test Laboratory: SPEAG Lab2

DUT: HAC Dipole 1880 MHz; Type: CD1880V3; Serial: 1036

Communication System: CW; Communication System Band: CD1880 (1880.0 MHz); Frequency: 1880 MHz;

Communication System PAR: 0 dB

Medium parameters used: $\sigma = 0$ mho/m, $\epsilon_r = 1$; $\rho = 1$ kg/m³

Phantom section: RF Section

Measurement Standard: DASY5 (IEEE/IEC/ANSI C63.19-2007)

DASY5 Configuration:

- Probe: H3DV6 - SN6065; ; Calibrated: 30.12.2009
- Sensor-Surface: (Fix Surface)
- Electronics: DAE4 Sn781; Calibrated: 22.01.2010
- Phantom: HAC Test Arch with AMCC; Type: SD HAC P01 BA; Serial: 1070
- Measurement SW: DASY52, V52.2 Build 0; Postprocessing SW: SEMCAD X, V14.2 Build 2Version 14.2.2 (1685)

Dipole H-Field measurement @ 1880MHz/H Scan - measurement distance from the probe sensor center to CD1880 Dipole = 10mm/Hearing Aid Compatibility Test (41x181x1):

Measurement grid: dx=5mm, dy=5mm

Maximum value of peak Total field = 0.468 A/m

Probe Modulation Factor = 1

Device Reference Point: 0, 0, -6.3 mm

Reference Value = 0.496 A/m; Power Drift = -0.00099 dB

Hearing Aid Near-Field Category: M2 (AWF 0 dB)

Peak H-field in A/m

Grid 1 0.404 M2	Grid 2 0.422 M2	Grid 3 0.400 M2
Grid 4 0.447 M2	Grid 5 0.468 M2	Grid 6 0.446 M2
Grid 7 0.408 M2	Grid 8 0.433 M2	Grid 9 0.411 M2

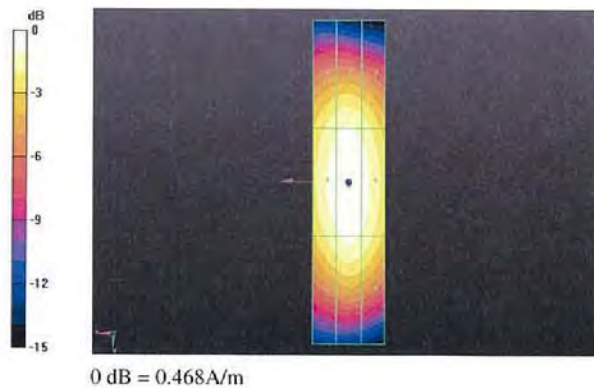

3.3.3 DASY4 E-Field Result

Date/Time: 13.07.2010 14:56:29

Test Laboratory: SPEAG Lab2

DUT: HAC Dipole 1880 MHz; Type: CD1880V3; Serial: 1036

Communication System: CW; Communication System Band: CD1880 (1880.0 MHz); Frequency: 1880 MHz;

Communication System PAR: 0 dB

Medium parameters used: $\sigma = 0$ mho/m, $\epsilon_r = 1$; $\rho = 1000$ kg/m³

Phantom section: RF Section

Measurement Standard: DASY5 (IEEE/IEC/ANSI C63.19-2007)

DASY5 Configuration:

- Probe: ER3DV6 - SN2336; ConvF(1, 1, 1); Calibrated: 30.12.2009
- Sensor-Surface: (Fix Surface)
- Electronics: DAE4 Sn781; Calibrated: 22.01.2010
- Phantom: HAC Test Arch with AMCC; Type: SD HAC P01 BA; Serial: 1070
- Measurement SW: DASY52, V52.2 Build 0; Postprocessing SW: SEMCAD X, V14.2 Build 2Version 14.2.2 (1685)

Dipole E-Field measurement @ 1880MHz/E Scan - measurement distance from the probe sensor center to CD1880 Dipole = 10mm/Hearing Aid Compatibility Test (41x181x1):

Measurement grid: dx=5mm, dy=5mm

Maximum value of peak Total field = 139.2 V/m

Probe Modulation Factor = 1

Device Reference Point: 0, 0, -6.3 mm

Reference Value = 156.8 V/m; Power Drift = 0.043 dB

Hearing Aid Near-Field Category: M2 (AWF 0 dB)

Peak E-field in V/m

Grid 1 132.8 M2	Grid 2 136.7 M2	Grid 3 133.9 M2
Grid 4 92.6 M3	Grid 5 95.1 M3	Grid 6 91.8 M3
Grid 7 130.6 M2	Grid 8 139.2 M2	Grid 9 137.4 M2

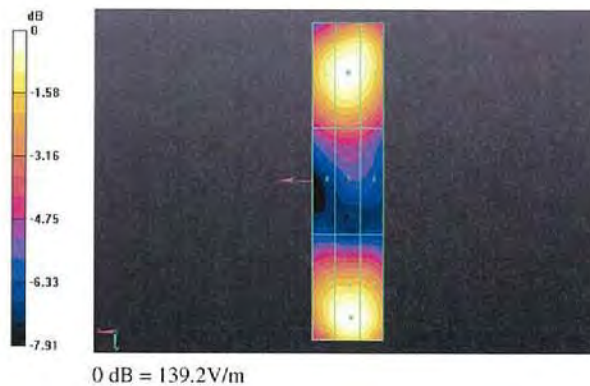

**Calibration Laboratory of
Schmid & Partner
Engineering AG**
Zeughausstrasse 43, 8004 Zurich, Switzerland



S Schweizerischer Kalibrierdienst
S Service suisse d'étalonnage
C Servizio svizzero di taratura
S Swiss Calibration Service

Accredited by the Swiss Accreditation Service (SAS)
The Swiss Accreditation Service is one of the signatories to the EA
Multilateral Agreement for the recognition of calibration certificates

Accreditation No.: **SCS 108**

Client **Auden**

Certificate No: **ER3-2302_Jun10**

CALIBRATION CERTIFICATE

Object: **ER3DV6 - SN:2302**

Calibration procedure(s): **QA CAL-02.v5 and QA CAL-25.v2
Calibration procedure for E-field probes optimized for close near field
evaluations in air**

Calibration date: **June 15, 2010**

This calibration certificate documents the traceability to national standards, which realize the physical units of measurements (SI).
The measurements and the uncertainties with confidence probability are given on the following pages and are part of the certificate.

All calibrations have been conducted in the closed laboratory facility: environment temperature (22 ± 3)°C and humidity < 70%.

Calibration Equipment used (M&TE critical for calibration)

Primary Standards	ID #	Cal Date (Certificate No.)	Scheduled Calibration
Power meter E4419B	GB41293874	1-Apr-10 (No. 217-01136)	Apr-11
Power sensor E4412A	MY41495277	1-Apr-10 (No. 217-01136)	Apr-11
Power sensor E4412A	MY41498087	1-Apr-10 (No. 217-01136)	Apr-11
Reference 3 dB Attenuator	SN: S5054 (3c)	30-Mar-10 (No. 217-01159)	Mar-11
Reference 20 dB Attenuator	SN: S5086 (20b)	30-Mar-10 (No. 217-01161)	Mar-11
Reference 30 dB Attenuator	SN: S5129 (30b)	30-Mar-10 (No. 217-01160)	Mar-11
Reference Probe ER3DV6	SN: 2328	3-Oct-09 (No. ER3-2328_Oct09)	Oct-10
DAE4	SN: 789	23-Dec-09 (No. DAE4-789_Dec09)	Dec-10

Secondary Standards	ID #	Check Date (in house)	Scheduled Check
RF generator HP 8648C	US3642U01700	4-Aug-99 (in house check Oct-09)	In house check: Oct-11
Network Analyzer HP 8753E	US37390585	18-Oct-01 (in house check Oct-09)	In house check: Oct-10

Calibrated by: **Claudio Leubler** (Name), **Laboratory Technician** (Function), *[Signature]* (Signature)

Approved by: **Katja Pokovic** (Name), **Technical Manager** (Function), *[Signature]* (Signature)

Issued: June 16, 2010

This calibration certificate shall not be reproduced except in full without written approval of the laboratory.

**Calibration Laboratory of
Schmid & Partner
Engineering AG**
Zeughausstrasse 43, 8004 Zurich, Switzerland



S Schweizerischer Kalibrierdienst
C Service suisse d'étalonnage
S Servizio svizzero di taratura
S Swiss Calibration Service

Accredited by the Swiss Accreditation Service (SAS)
The Swiss Accreditation Service is one of the signatories to the EA
Multilateral Agreement for the recognition of calibration certificates

Accreditation No.: **SCS 108**

Glossary:

NORM _{x,y,z}	sensitivity in free space
DCP	diode compression point
CF	crest factor (1/duty_cycle) of the RF signal
A, B, C	modulation dependent linearization parameters
Polarization φ	φ rotation around probe axis
Polarization ϑ	ϑ rotation around an axis that is in the plane normal to probe axis (at measurement center), i.e., $\vartheta = 0$ is normal to probe axis
Connector Angle	information used in DASY system to align probe sensor X to the robot coordinate system

Calibration is Performed According to the Following Standards:

- IEEE Std 1309-2005, "IEEE Standard for calibration of electromagnetic field sensors and probes, excluding antennas, from 9 kHz to 40 GHz", December 2005.

Methods Applied and Interpretation of Parameters:

- NORM_{x,y,z}*: Assessed for E-field polarization $\vartheta = 0$ for XY sensors and $\vartheta = 90$ for Z sensor ($f \leq 900$ MHz in TEM-cell; $f > 1800$ MHz: R22 waveguide).
- NORM(f)_{x,y,z}* = *NORM_{x,y,z}* * *frequency_response* (see Frequency Response Chart).
- DCP_{x,y,z}*: DCP are numerical linearization parameters assessed based on the data of power sweep with CW signal (no uncertainty required). DCP does not depend on frequency nor media.
- A_{x,y,z}; B_{x,y,z}; C_{x,y,z}; VR_{x,y,z}*: A, B, C are numerical linearization parameters assessed based on the data of power sweep for specific modulation signal. The parameters do not depend on frequency nor media. VR is the maximum calibration range expressed in RMS voltage across the diode.
- Spherical isotropy (3D deviation from isotropy)*: in a locally homogeneous field realized using an open waveguide setup.
- Sensor Offset*: The sensor offset corresponds to the offset of virtual measurement center from the probe tip (on probe axis). No tolerance required.
- Connector Angle*: The angle is assessed using the information gained by determining the *NORM_x* (no uncertainty required).



ER3DV6 SN:2302

June 15, 2010

Probe ER3DV6

SN:2302

Manufactured:	November 6, 2002
Last calibrated:	June 23, 2009
Recalibrated:	June 15, 2010

Calibrated for DASY/EASY Systems

(Note: non-compatible with DASY2 system!)



ER3DV6 SN:2302

June 15, 2010

DASY/EASY - Parameters of Probe: ER3DV6 SN:2302

Basic Calibration Parameters

	Sensor X	Sensor Y	Sensor Z	Unc (k=2)
Norm ($\mu\text{V}/(\text{V}/\text{m})^2$)	1.49	1.36	1.46	$\pm 10.1\%$
DCP (mV) ^A	91.2	91.4	100.2	

Modulation Calibration Parameters

UID	Communication System Name	PAR		A dB	B dBuV	C	VR mV	Unc ^E (k=2)
10000	CW	0.00	X	0.00	0.00	1.00	300	$\pm 1.5\%$
			Y	0.00	0.00	1.00	300	
			Z	0.00	0.00	1.00	300	

The reported uncertainty of measurement is stated as the standard uncertainty of measurement multiplied by the coverage factor k=2, which for a normal distribution corresponds to a coverage probability of approximately 95%.

^A numerical linearization parameter: uncertainty not required

^E Uncertainty is determined using the maximum deviation from linear response applying rectangular distribution and is expressed for the square of the field value.

Frequency Response of E-Field (TEM-Cell:ifi110 EXX, Waveguide R22)

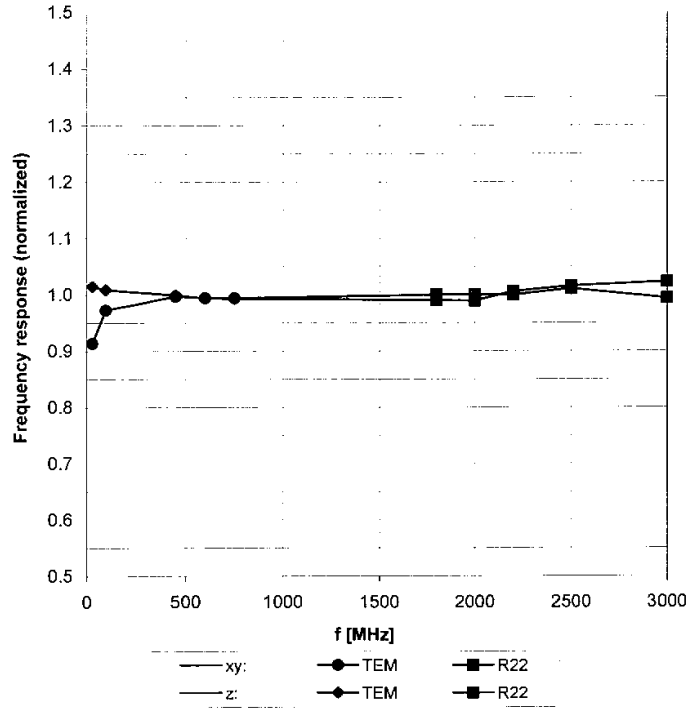

Uncertainty of Frequency Response of E-field: $\pm 6.3\%$ (k=2)

Receiving Pattern (ϕ), $\vartheta = 0^\circ$

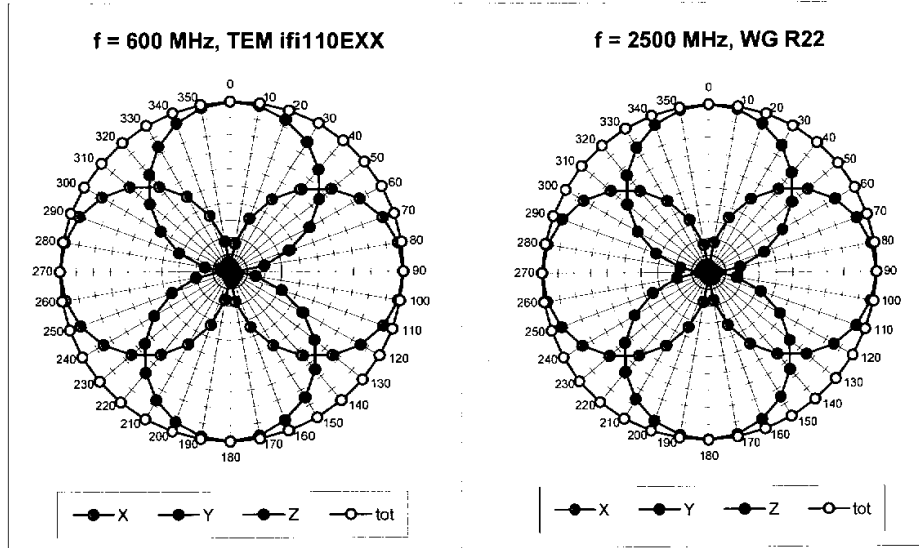

Receiving Pattern (ϕ), $\vartheta = 90^\circ$

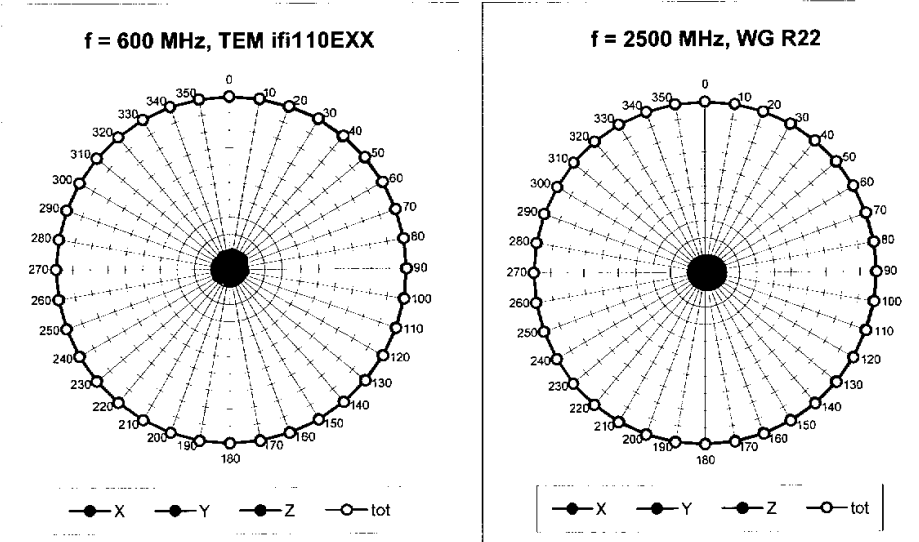

Receiving Pattern (ϕ), $\vartheta = 0^\circ$

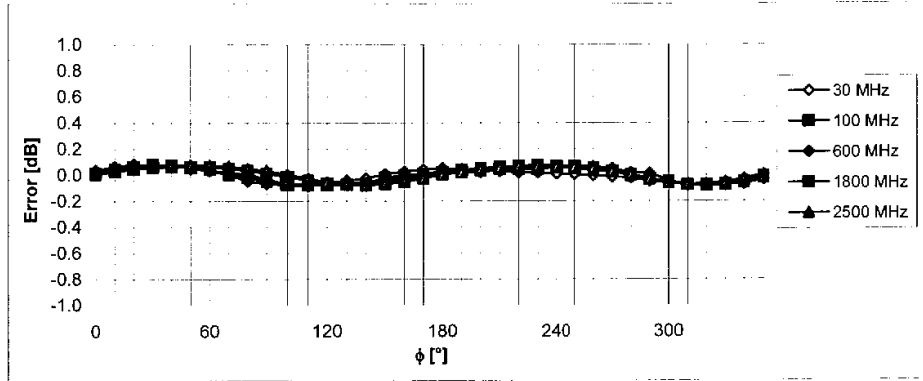

Uncertainty of Axial Isotropy Assessment: $\pm 0.5\%$ (k=2)

Receiving Pattern (ϕ), $\vartheta = 90^\circ$

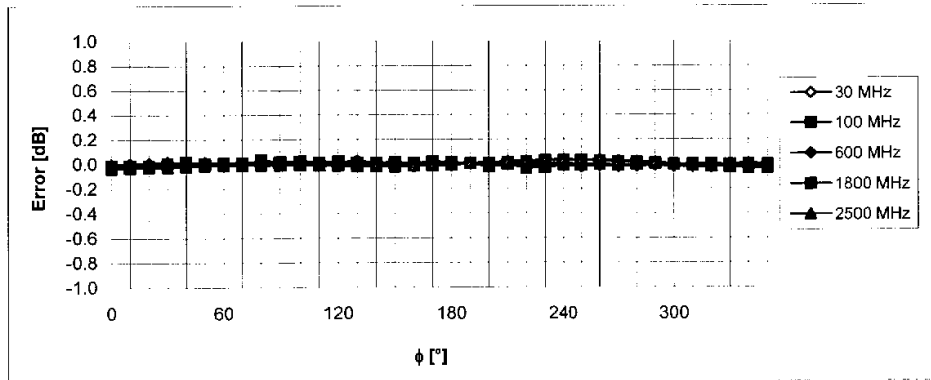

Uncertainty of Axial Isotropy Assessment: $\pm 0.5\%$ (k=2)

Dynamic Range f(E-field) (Waveguide R22, f = 1800 MHz)

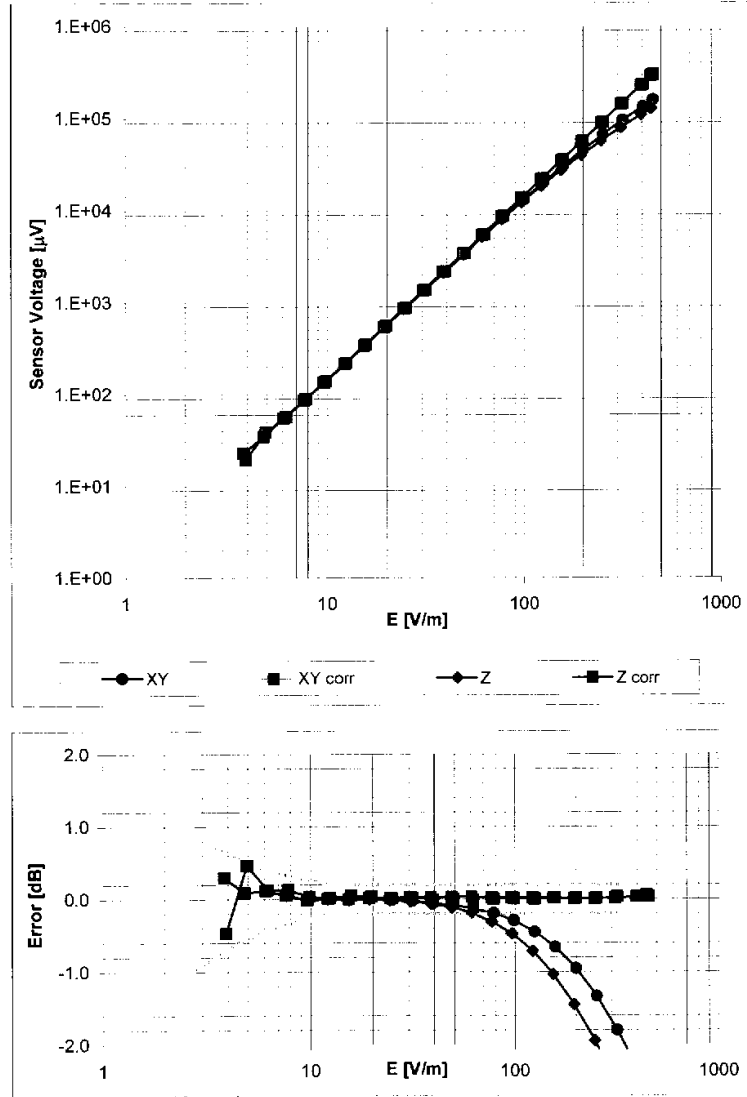

Uncertainty of Linearity Assessment: $\pm 0.6\%$ (k=2)

Deviation from Isotropy in Air Error (ϕ, ϑ), $f = 900 \text{ MHz}$

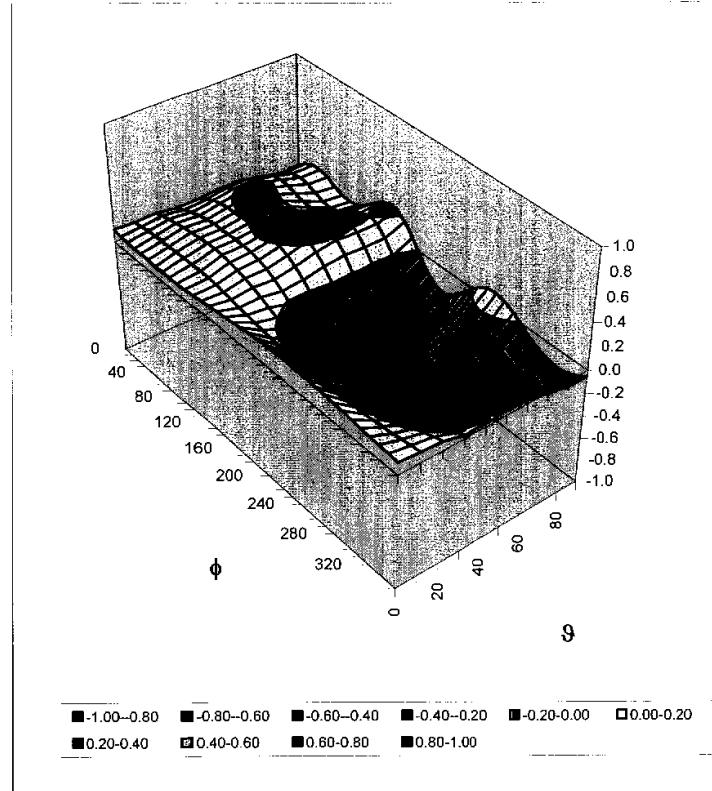

Uncertainty of Spherical Isotropy Assessment: $\pm 2.6\%$ ($k=2$)



Other Probe Parameters

Sensor Arrangement	Rectangular
Connector Angle (°)	-3.5
Mechanical Surface Detection Mode	enabled
Optical Surface Detection Mode	disabled
Probe Overall Length	337 mm
Probe Body Diameter	10 mm
Tip Length	10 mm
Tip Diameter	8.0 mm
Probe Tip to Sensor X Calibration Point	2.5 mm
Probe Tip to Sensor Y Calibration Point	2.5 mm
Probe Tip to Sensor Z Calibration Point	2.5 mm

**Calibration Laboratory of
Schmid & Partner
Engineering AG**
Zeughausstrasse 43, 8004 Zurich, Switzerland



S Schweizerischer Kalibrierdienst
S Service suisse d'étalonnage
C Servizio svizzero di taratura
S Swiss Calibration Service

Accredited by the Swiss Accreditation Service (SAS)
The Swiss Accreditation Service is one of the signatories to the EA
Multilateral Agreement for the recognition of calibration certificates

Accreditation No.: **SCS 108**

Client **Auden**

Certificate No: **H3-6187_Jun10**

CALIBRATION CERTIFICATE

Object: **H3DV6 - SN:6187**

Calibration procedure(s): **QA CAL-03.v5 and QA CAL-25.v2
Calibration procedure for H-field probes optimized for close near field
evaluations in air**

Calibration date: **June 15, 2010**



This calibration certificate documents the traceability to national standards, which realize the physical units of measurements (SI).
The measurements and the uncertainties with confidence probability are given on the following pages and are part of the certificate.

All calibrations have been conducted in the closed laboratory facility: environment temperature (22 ± 3)°C and humidity < 70%.

Calibration Equipment used (M&TE critical for calibration)

Primary Standards	ID #	Cal Date (Certificate No.)	Scheduled Calibration
Power meter E4419B	GB41293874	1-Apr-10 (No. 217-01136)	Apr-11
Power sensor E4412A	MY41495277	1-Apr-10 (No. 217-01136)	Apr-11
Power sensor E4412A	MY41498087	1-Apr-10 (No. 217-01136)	Apr-11
Reference 3 dB Attenuator	SN: S5054 (3c)	30-Mar-10 (No. 217-01159)	Mar-11
Reference 20 dB Attenuator	SN: S5086 (20b)	30-Mar-10 (No. 217-01161)	Mar-11
Reference 30 dB Attenuator	SN: S5129 (30b)	30-Mar-10 (No. 217-01160)	Mar-11
Reference Probe H3DV6	SN: 6182	3-Oct-09 (No. H3-6182_Oct09)	Oct-10
DAE4	SN: 789	23-Dec-09 (No. DAE4-789_Dec09)	Dec-10

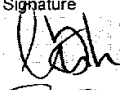
Secondary Standards	ID #	Check Date (in house)	Scheduled Check
RF generator HP 8648C	US3642U01700	4-Aug-99 (in house check Oct-09)	In house check: Oct-11
Network Analyzer HP 8753E	US37390585	18-Oct-01 (in house check Oct-09)	In house check: Oct-10

Calibrated by:	Name Claudio Leubler	Function Laboratory Technician	Signature 
Approved by:	Name Katja Pokovic	Function Technical Manager	

Issued: June 16, 2010

This calibration certificate shall not be reproduced except in full without written approval of the laboratory.

**Calibration Laboratory of
Schmid & Partner
Engineering AG**
Zeughausstrasse 43, 8004 Zurich, Switzerland



S Schweizerischer Kalibrierdienst
C Service suisse d'étalonnage
S Servizio svizzero di taratura
S Swiss Calibration Service

Accredited by the Swiss Accreditation Service (SAS)
The Swiss Accreditation Service is one of the signatories to the EA
Multilateral Agreement for the recognition of calibration certificates

Accreditation No.: **SCS 108**

Glossary:

NORM _{x,y,z}	sensitivity in free space
DCP	diode compression point
CF	crest factor (1/duty_cycle) of the RF signal
A, B, C	modulation dependent linearization parameters
Polarization φ	φ rotation around probe axis
Polarization ϑ	ϑ rotation around an axis that is in the plane normal to probe axis (at measurement center), i.e., $\vartheta = 0$ is normal to probe axis
Connector Angle	information used in DASY system to align probe sensor X to the robot coordinate system

Calibration is Performed According to the Following Standards:

- a) IEEE Std 1309-2005, "IEEE Standard for calibration of electromagnetic field sensors and probes, excluding antennas, from 9 kHz to 40 GHz", December 2005.

Methods Applied and Interpretation of Parameters:

- *NORM_{x,y,z}*: Assessed for E-field polarization $\vartheta = 0$ for XY sensors and $\vartheta = 90$ for Z sensor ($f \leq 900$ MHz in TEM-cell; $f > 1800$ MHz: R22 waveguide).
- *X, Y, Z(f)_a0a1a2 = X, Y, Z_a0a1a2 * frequency_response* (see Frequency Response Chart).
- *DCP_{x,y,z}*: DCP are numerical linearization parameters assessed based on the data of power sweep with CW signal (no uncertainty required). DCP does not depend on frequency nor media.
- *A_{x,y,z}; B_{x,y,z}; C_{x,y,z}; VR_{x,y,z}*: A, B, C are numerical linearization parameters assessed based on the data of power sweep for specific modulation signal. The parameters do not depend on frequency nor media. VR is the maximum calibration range expressed in RMS voltage across the diode.
- *Spherical isotropy (3D deviation from isotropy)*: in a locally homogeneous field realized using an open waveguide setup.
- *Sensor Offset*: The sensor offset corresponds to the offset of virtual measurement center from the probe tip (on probe axis). No tolerance required.
- *Connector Angle*: The angle is assessed using the information gained by determining the *X_a0a1a2* (no uncertainty required).



H3DV6 SN:6187

June 15, 2010

Probe H3DV6

SN:6187

Manufactured:	June 8, 2004
Last calibrated:	June 24, 2009
Recalibrated:	June 15, 2010

Calibrated for DASY/EASY Systems

(Note: non-compatible with DASY2 system!)



DASY/EASY - Parameters of Probe: H3DV6 SN:6187

Basic Calibration Parameters

		Sensor X	Sensor Y	Sensor Z	Unc (k=2)
Norm (A/m / $\sqrt{\mu V}$)	a0	3.29E-3	2.52E-3	3.04E-3	$\pm 5.1\%$
Norm (A/m / $\sqrt{\mu V}$)	a1	-2.89E-6	3.58E-5	-4.67E-5	$\pm 5.1\%$
Norm (A/m / $\sqrt{\mu V}$)	a2	1.52E-5	1.18E-5	6.41E-5	$\pm 5.1\%$
DCP (mV) ^A		101.0	93.0	83.2	

Modulation Calibration Parameters

UID	Communication System Name	PAR		A dB	B dBuV	C	VR mV	Unc ^E (k=2)
10000	CW	0.00	X	0.00	0.00	1.00	300	$\pm 1.5\%$
			Y	0.00	0.00	1.00	300	
			Z	0.00	0.00	1.00	300	

The reported uncertainty of measurement is stated as the standard uncertainty of measurement multiplied by the coverage factor k=2, which for a normal distribution corresponds to a coverage probability of approximately 95%.

^A numerical linearization parameter: uncertainty not required

^E Uncertainty is determined using the maximum deviation from linear response applying recatangular distribution and is expressed for the square of the field value.

Frequency Response of H-Field (TEM-Cell:ifi110 EXX, Waveguide R22)

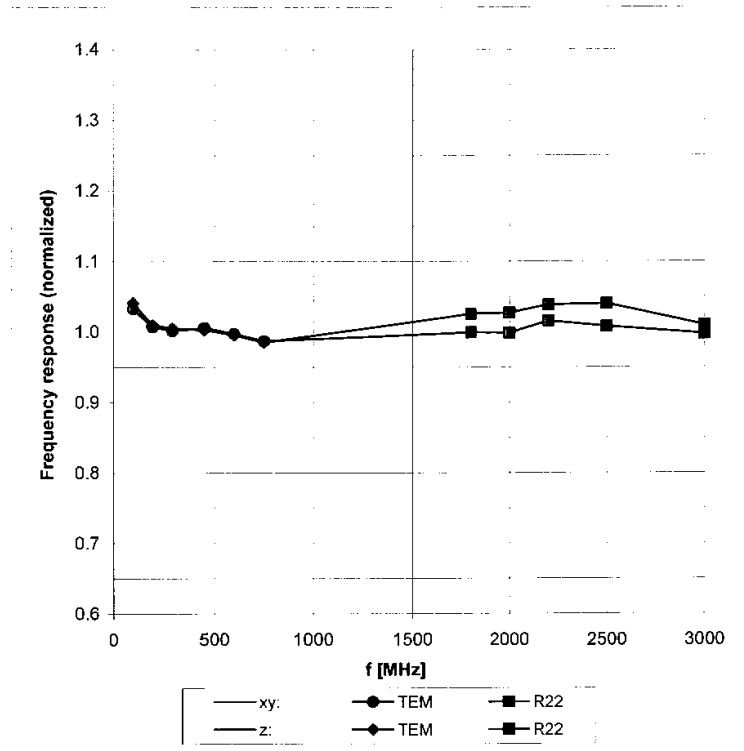

Uncertainty of Frequency Response of H-field: $\pm 6.3\%$ (k=2)

Receiving Pattern (ϕ), $\vartheta = 90^\circ$

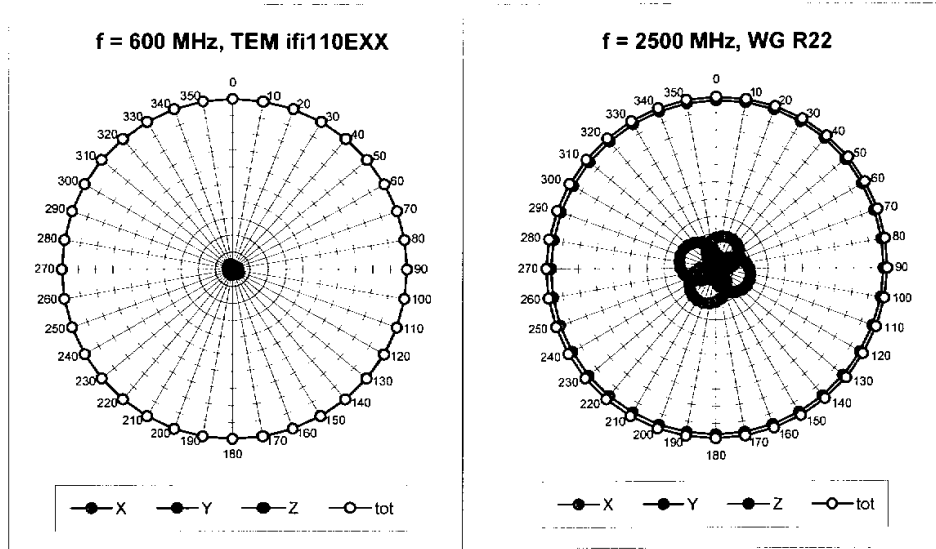

Receiving Pattern (ϕ), $\vartheta = 0^\circ$

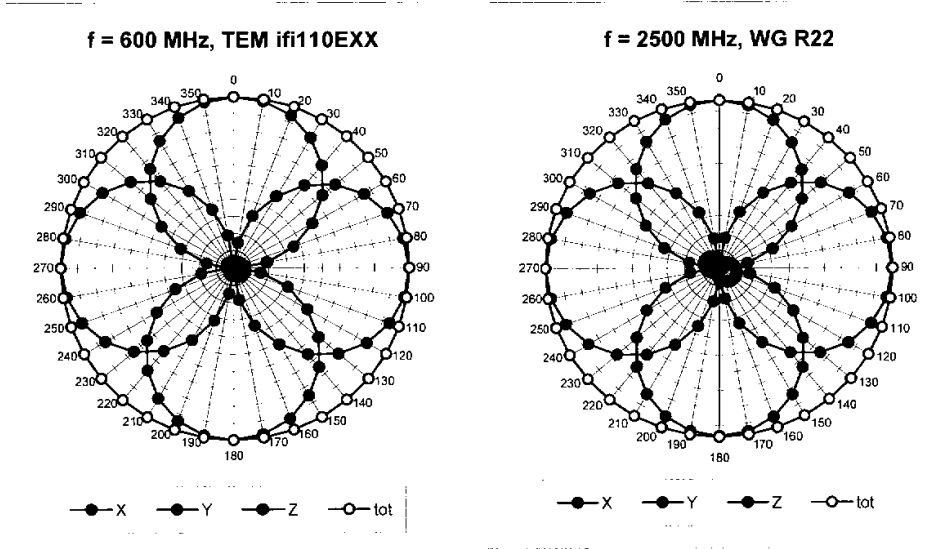

Receiving Pattern (ϕ), $\vartheta = 90^\circ$

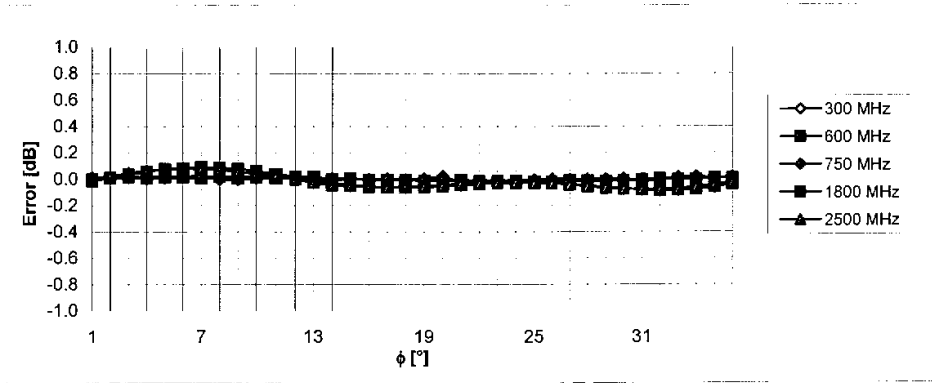

Uncertainty of Axial Isotropy Assessment: $\pm 0.5\%$ (k=2)

Receiving Pattern (ϕ), $\vartheta = 0^\circ$

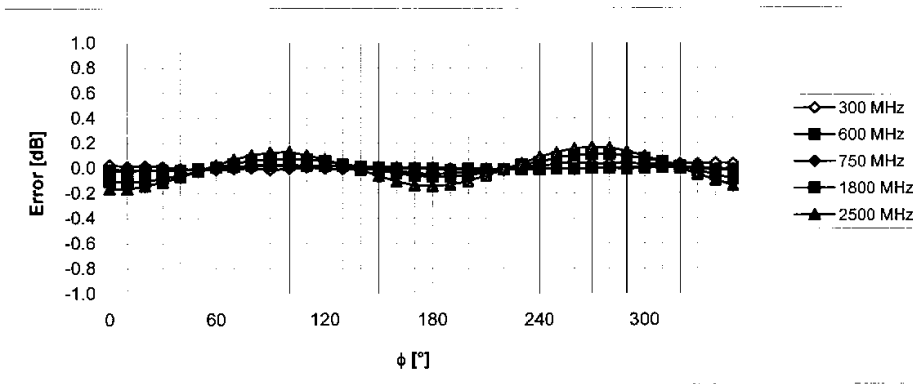

Uncertainty of Axial Isotropy Assessment: $\pm 0.5\%$ (k=2)

Dynamic Range f(H-field) (Waveguide R22, f = 1800 MHz)

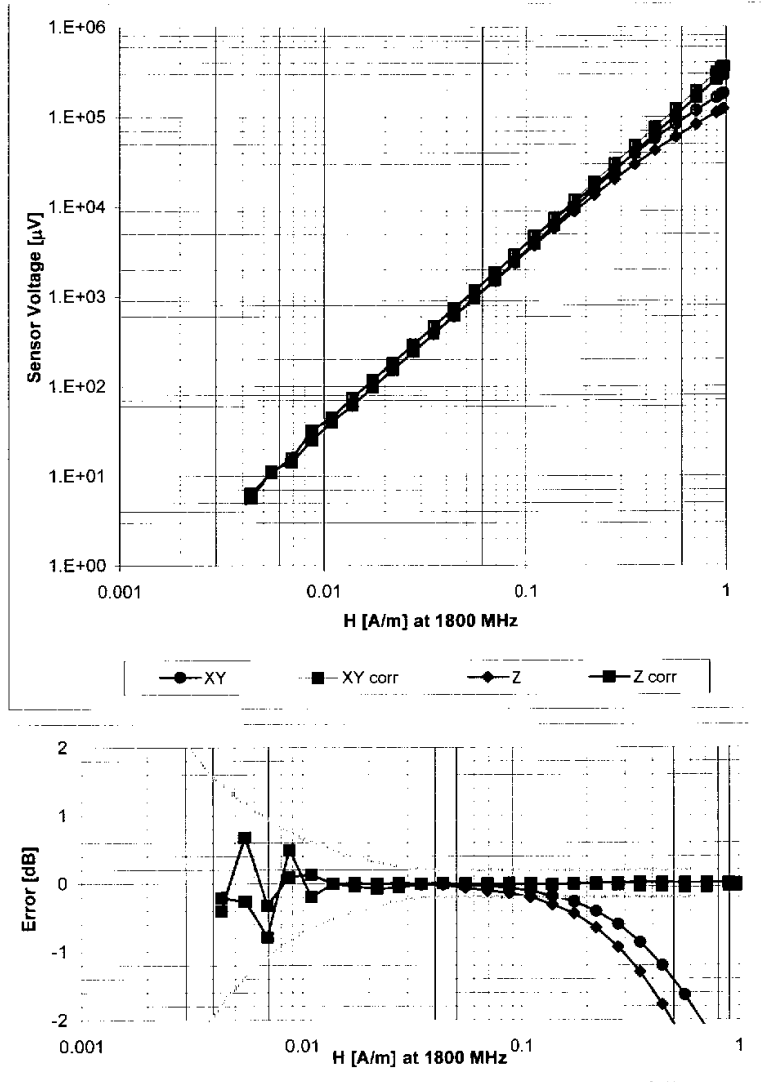

Uncertainty of Linearity Assessment: $\pm 0.6\%$ ($k=2$)

Deviation from Isotropy in Air Error (ϕ, ϑ), $f = 900 \text{ MHz}$

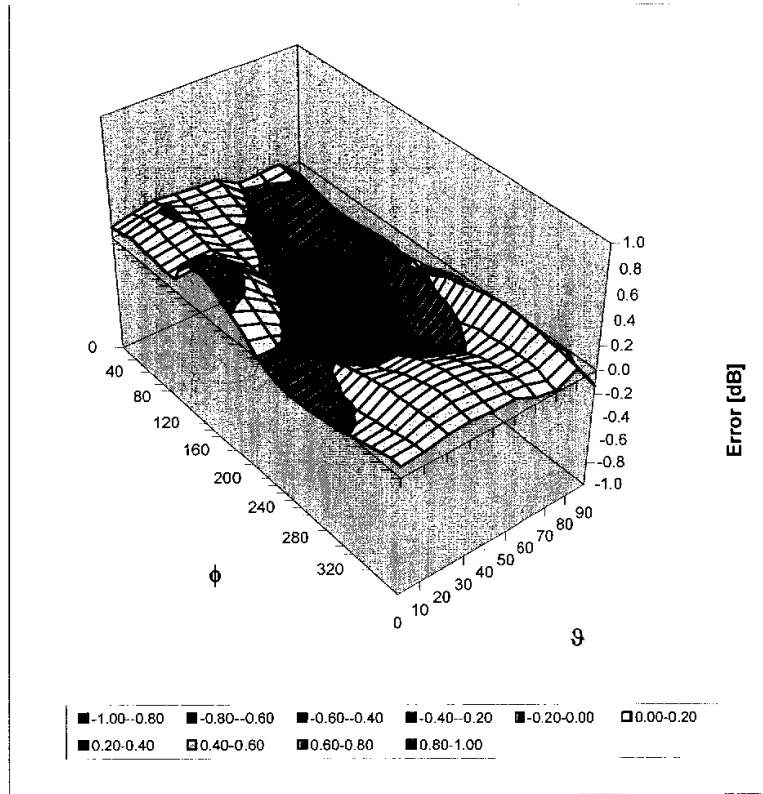

Uncertainty of Spherical Isotropy Assessment: $\pm 2.6\%$ ($k=2$)



Other Probe Parameters

Sensor Arrangement	Rectangular
Connector Angle (°)	-113.9
Mechanical Surface Detection Mode	enabled
Optical Surface Detection Mode	disabled
Probe Overall Length	337 mm
Probe Body Diameter	10 mm
Tip Length	20 mm
Tip Diameter	6.0 mm
Probe Tip to Sensor X Calibration Point	3 mm
Probe Tip to Sensor Y Calibration Point	3 mm
Probe Tip to Sensor Z Calibration Point	3 mm



Calibration Laboratory of
 Schmid & Partner
 Engineering AG
 Zeughausstrasse 43, 8004 Zurich, Switzerland



S Schweizerischer Kalibrierdienst
S Service suisse d'étalonnage
C Servizio svizzero di taratura
S Swiss Calibration Service

Accredited by the Swiss Accreditation Service (SAS)
 The Swiss Accreditation Service is one of the signatories to the EA
 Multilateral Agreement for the recognition of calibration certificates

Accreditation No.: **SCS 108**

Client **ATL (Auden)**

Certificate No: **DAE4-779_Jan10**

CALIBRATION CERTIFICATE

Object: **DAE4 - SD 000 D04 BJ - SN: 779**

Calibration procedure(s): **QA CAL-06.v12
 Calibration procedure for the data acquisition electronics (DAE)**

Calibration date: **January 21, 2010**

This calibration certificate documents the traceability to national standards, which realize the physical units of measurements (SI).
 The measurements and the uncertainties with confidence probability are given on the following pages and are part of the certificate.

All calibrations have been conducted in the closed laboratory facility: environment temperature (22 ± 3)°C and humidity < 70%.

Calibration Equipment used (M&TE critical for calibration)

Primary Standards	ID #	Cal Date (Certificate No.)	Scheduled Calibration
Keithley Multimeter Type 2001	SN: 0810278	1-Oct-09 (No: 9055)	Oct-10
Secondary Standards	ID #	Check Date (in house)	Scheduled Check
Calibrator Box V1.1	SE UMS 006 AB 1004	05-Jun-09 (in house check)	In house check: Jun-10

Calibrated by:	Name Andrea Guntli	Function Technician	Signature
Approved by:	Fin Bomholt	R&D Director	

Issued: January 21, 2010

This calibration certificate shall not be reproduced except in full without written approval of the laboratory.

Calibration Laboratory of
Schmid & Partner
Engineering AG
Zeughausstrasse 43, 8004 Zurich, Switzerland



S Schweizerischer Kalibrierdienst
C Service suisse d'étalonnage
S Servizio svizzero di taratura
S Swiss Calibration Service

Accredited by the Swiss Accreditation Service (SAS)
The Swiss Accreditation Service is one of the signatories to the EA
Multilateral Agreement for the recognition of calibration certificates

Accreditation No.: **SCS 108**

Glossary

DAE data acquisition electronics
Connector angle information used in DASY system to align probe sensor X to the robot coordinate system.

Methods Applied and Interpretation of Parameters

- *DC Voltage Measurement:* Calibration Factor assessed for use in DASY system by comparison with a calibrated instrument traceable to national standards. The figure given corresponds to the full scale range of the voltmeter in the respective range.
- *Connector angle:* The angle of the connector is assessed measuring the angle mechanically by a tool inserted. Uncertainty is not required.
- The following parameters as documented in the Appendix contain technical information as a result from the performance test and require no uncertainty.
 - *DC Voltage Measurement Linearity:* Verification of the Linearity at +10% and -10% of the nominal calibration voltage. Influence of offset voltage is included in this measurement.
 - *Common mode sensitivity:* Influence of a positive or negative common mode voltage on the differential measurement.
 - *Channel separation:* Influence of a voltage on the neighbor channels not subject to an input voltage.
 - *AD Converter Values with inputs shorted:* Values on the internal AD converter corresponding to zero input voltage
 - *Input Offset Measurement:* Output voltage and statistical results over a large number of zero voltage measurements.
 - *Input Offset Current:* Typical value for information; Maximum channel input offset current, not considering the input resistance.
 - *Input resistance:* DAE input resistance at the connector, during internal auto-zeroing and during measurement.
 - *Low Battery Alarm Voltage:* Typical value for information. Below this voltage, a battery alarm signal is generated.
 - *Power consumption:* Typical value for information. Supply currents in various operating modes.



DC Voltage Measurement

A/D - Converter Resolution nominal

High Range: 1LSB = 6.1 μ V, full range = -100...+300 mV

Low Range: 1LSB = 61nV, full range = -1.....+3mV

DASY measurement parameters: Auto Zero Time: 3 sec; Measuring time: 3 sec

Calibration Factors	X	Y	Z
High Range	404.487 \pm 0.1% (k=2)	403.723 \pm 0.1% (k=2)	403.948 \pm 0.1% (k=2)
Low Range	3.97046 \pm 0.7% (k=2)	3.98719 \pm 0.7% (k=2)	4.00014 \pm 0.7% (k=2)

Connector Angle

Connector Angle to be used in DASY system	84.5 \pm 1 $^{\circ}$
---	-------------------------



Appendix

1. DC Voltage Linearity

High Range	Reading (μV)	Difference (μV)	Error (%)
Channel X + Input	200010.5	1.14	0.00
Channel X + Input	20003.28	3.68	0.02
Channel X - Input	-19997.24	3.06	-0.02
Channel Y + Input	200009.6	0.87	0.00
Channel Y + Input	19999.83	0.43	0.00
Channel Y - Input	-19998.10	2.10	-0.01
Channel Z + Input	199998.4	0.15	0.00
Channel Z + Input	20000.44	1.04	0.01
Channel Z - Input	-19997.62	-0.01	-0.01

Low Range	Reading (μV)	Difference (μV)	Error (%)
Channel X + Input	1999.6	-0.33	-0.02
Channel X + Input	199.84	-0.16	-0.08
Channel X - Input	-200.02	-0.22	0.11
Channel Y + Input	2000.1	0.05	0.00
Channel Y + Input	198.87	-1.13	-0.56
Channel Y - Input	-201.72	-1.62	0.81
Channel Z + Input	2000.2	0.14	0.01
Channel Z + Input	199.12	-1.18	-0.59
Channel Z - Input	-200.60	-0.60	0.30

2. Common mode sensitivity

DASY measurement parameters: Auto Zero Time: 3 sec; Measuring time: 3 sec

	Common mode Input Voltage (mV)	High Range Average Reading (μV)	Low Range Average Reading (μV)
Channel X	200	-3.75	-5.42
	- 200	6.52	4.96
Channel Y	200	14.47	13.94
	- 200	-14.47	-14.52
Channel Z	200	3.70	3.28
	- 200	-3.73	-3.84

3. Channel separation

DASY measurement parameters: Auto Zero Time: 3 sec; Measuring time: 3 sec

	Input Voltage (mV)	Channel X (μV)	Channel Y (μV)	Channel Z (μV)
Channel X	200	-	2.60	0.09
Channel Y	200	1.31	-	3.04
Channel Z	200	2.43	-2.04	-



4. AD-Converter Values with inputs shorted

DASY measurement parameters: Auto Zero Time: 3 sec; Measuring time: 3 sec

	High Range (LSB)	Low Range (LSB)
Channel X	15621	15863
Channel Y	15831	16095
Channel Z	16132	15816

5. Input Offset Measurement

DASY measurement parameters: Auto Zero Time: 3 sec; Measuring time: 3 sec

Input 10M Ω

	Average (μ V)	min. Offset (μ V)	max. Offset (μ V)	Std. Deviation (μ V)
Channel X	-0.14	-1.27	1.10	0.43
Channel Y	-0.91	-2.36	0.81	0.61
Channel Z	-1.02	-1.92	0.28	0.44

6. Input Offset Current

Nominal Input circuitry offset current on all channels: <25fA

7. Input Resistance

	Zeroing (MOhm)	Measuring (MOhm)
Channel X	0.1999	202.7
Channel Y	0.1999	202.5
Channel Z	0.2000	202.7

8. Low Battery Alarm Voltage (verified during pre test)

Typical values	Alarm Level (VDC)
Supply (+ Vcc)	+7.9
Supply (- Vcc)	-7.6

9. Power Consumption (verified during pre test)

Typical values	Switched off (mA)	Stand by (mA)	Transmitting (mA)
Supply (+ Vcc)	+0.0	+6	+14
Supply (- Vcc)	-0.01	-8	-9



Appendix E - Uncertainty

HAC Uncertainty Budget According to NSIC63.19 [1], [2]							
Error Description	Uncertainty value	Prob. Dist.	Div.	(ci) E	(ci) H	Std. Unc. E	Std. Unc. H
Measurement System							
Probe Calibration	±5.1%	N	1	1	1	±5.1%	±5.1%
Axial Isotropy	±4.7%	R	$\sqrt{3}$	1	1	±2.7%	±2.7%
Sensor Displacement	±16.5%	R	$\sqrt{3}$	1	0.145	±9.5%	±1.4%
Test Arch	±7.2%	R	$\sqrt{3}$	1	0	±4.02%	±0.0%
Linearity	±4.7%	R	$\sqrt{3}$	1	1	±2.7%	±2.7%
Probe modulation Factor	±15.0%	R	$\sqrt{3}$	1	1	±8.7%	±8.7%
Scaling to Peak Envelope Power	±0.0%	R	$\sqrt{3}$	1	1	±0.0%	±0.0%
System Detection Limit	±1.0%	R	$\sqrt{3}$	1	1	±0.6%	±0.6%
Readout Electronics	±0.3%	N	1	1	1	±0.3%	±0.3%
Response Time	±0.8%	R	$\sqrt{3}$	1	1	±0.5%	±0.5%
Integration Time	±2.6%	R	$\sqrt{3}$	1	1	±1.5%	±1.5%
RF Ambient Conditions	±3.0%	R	$\sqrt{3}$	1	1	±1.7%	±1.7%
RF Reflections	±12.0%	R	$\sqrt{3}$	1	1	±6.9%	±6.9%
Probe Positioner	±1.2%	R	$\sqrt{3}$	1	0.67	±0.7%	±0.5%
Probe Positioning	±4.7%	R	$\sqrt{3}$	1	0.67	±2.7%	±1.8%
Extrap. and Interpolation	±1.0%	R	$\sqrt{3}$	1	1	±0.6%	±0.6%
Test Sample Related							
Device Positioning Vertical	±4.7%	R	$\sqrt{3}$	1	0.67	±2.7%	±1.8%
Device Positioning Lateral	±1.0%	R	$\sqrt{3}$	1	1	±0.6%	±0.6%
Device Holder and Phantom	±2.4%	R	$\sqrt{3}$	1	1	±1.4%	±1.4%
Power Drift	±5.0%	R	$\sqrt{3}$	1	1	±2.9%	±2.9%
Phantom and Setup Related							
Phantom Thickness	±2.4%	R	$\sqrt{3}$	1	0.67	±1.4%	±0.9%
Combined Std. Uncertainty		RSS				±17.5%	±13.8%
Expanded Std. Uncertainty on Power		K=2				±35.0%	±27.6%
Expanded Std. Uncertainty on Field						±17.5%	±13.8%