

# FCC RF Test Report

APPLICANT : HTC Corporation  
EQUIPMENT : Smartphone  
MODEL NAME : PD42100  
FCC ID : NM8PD42100  
STANDARD : FCC 47 CFR Part 2, 22(H), 24(E)  
CLASSIFICATION : PCS Licensed Transmitter Held to Ear (PCE)  
Tx/Rx FREQUENCY RANGE : CDMA2000 BC0 : 824.70 ~ 848.31 MHz /  
869.70 ~ 893.31 MHz  
CDMA2000 BC1 : 1851.25 ~ 1908.75 MHz /  
1931.25 ~ 1988.75 MHz  
MAX. ERP/EIRP POWER : <Sample 1>  
CDMA2000 BC0 : 0.11 W  
CDMA2000 BC1 : 0.23 W  
<Sample 2>  
CDMA2000 BC0 : 0.09 W  
CDMA2000 BC1 : 0.23 W  
EMISSION DESIGNATOR : 1M27F9W

The product was received on Jul. 21, 2010 and completely tested on Aug. 05, 2010. We, SPORTON INTERNATIONAL INC., would like to declare that the tested sample has been evaluated in accordance with the procedures given in ANSI / TIA / EIA-603-C-2004 and shown compliance with the applicable technical standards.

The test results in this report apply exclusively to the tested model / sample. Without written approval of SPORTON INTERNATIONAL INC., the test report shall not be reproduced except in full.

Reviewed by:



Anderson Chiu / Deputy Manager



## SPORTON INTERNATIONAL INC.

No. 52, Hwa Ya 1<sup>st</sup> Rd., Hwa Ya Technology Park, Kwei-Shan Hsiang, Tao Yuan Hsien, Taiwan, R.O.C.

SPORTON INTERNATIONAL INC.

TEL : 886-3-327-3456

FAX : 886-3-328-4978

FCC ID : NM8PD42100

Page Number : 1 of 42

Report Issued Date : Aug. 27, 2010

Report Version : Rev. 01



# TABLE OF CONTENTS

**REVISION HISTORY..... 3**

**SUMMARY OF TEST RESULT ..... 4**

**1 GENERAL DESCRIPTION ..... 5**

    1.1 Applicant..... 5

    1.2 Manufacturer ..... 5

    1.3 Feature of Equipment Under Test..... 5

    1.4 Testing Site..... 6

    1.5 Applied Standards ..... 6

    1.6 Ancillary Equipment List ..... 6

**2 TEST CONFIGURATION OF EQUIPMENT UNDER TEST ..... 7**

    2.1 Test Mode..... 7

    2.2 Connection Diagram of Test System ..... 8

**3 TEST RESULT ..... 9**

    3.1 Conducted Output Power Measurement ..... 9

    3.2 Effective Radiated Power and Effective Isotropic Radiated Power Measurement ..... 11

    3.3 Occupied Bandwidth Measurement ..... 15

    3.4 Band Edge Measurement..... 18

    3.5 Conducted Emission Measurement ..... 21

    3.6 Field Strength of Spurious Radiation Measurement ..... 27

    3.7 Frequency Stability Measurement..... 37

**4 LIST OF MEASURING EQUIPMENT ..... 41**

**5 UNCERTAINTY OF EVALUATION ..... 42**

**APPENDIX A. SETUP PHOTOGRAPHS**



## REVISION HISTORY

| REPORT NO. | VERSION | DESCRIPTION             | ISSUED DATE   |
|------------|---------|-------------------------|---------------|
| FG072126   | Rev. 01 | Initial issue of report | Aug. 27, 2010 |
|            |         |                         |               |
|            |         |                         |               |
|            |         |                         |               |
|            |         |                         |               |
|            |         |                         |               |
|            |         |                         |               |
|            |         |                         |               |
|            |         |                         |               |
|            |         |                         |               |
|            |         |                         |               |
|            |         |                         |               |
|            |         |                         |               |
|            |         |                         |               |
|            |         |                         |               |
|            |         |                         |               |
|            |         |                         |               |
|            |         |                         |               |
|            |         |                         |               |



## SUMMARY OF TEST RESULT

| Report Section | FCC Rule                            | IC Rule                            | Description                                   | Limit                               | Result | Remark                                     |
|----------------|-------------------------------------|------------------------------------|-----------------------------------------------|-------------------------------------|--------|--------------------------------------------|
| 3.1            | §2.1046                             | N/A                                | Conducted Output Power                        | N/A                                 | PASS   | -                                          |
| 3.2            | §22.913(a)(2)                       | RSS-132(4.4)<br>SRSP-503(5.1.3)    | Effective Radiated Power                      | < 7 Watts                           | PASS   | -                                          |
| 3.2            | §24.232(c)                          | RSS-133 (6.4)<br>SRSP-510(5.1.2)   | Equivalent Isotropic Radiated Power           | < 2 Watts                           | PASS   | -                                          |
| 3.3            | §2.1049<br>§22.917(a)<br>§24.238(a) | N/A                                | Occupied Bandwidth                            | N/A                                 | PASS   | -                                          |
| 3.4            | §2.1051<br>§22.917(a)<br>§24.238(a) | RSS-132 (4.5.1)<br>RSS-133 (6.5.1) | Band Edge Measurement                         | < 43+10log <sub>10</sub> (P[Watts]) | PASS   | -                                          |
| 3.5            | §2.1051<br>§22.917(a)<br>§24.238(a) | RSS-132 (4.5.1)<br>RSS-133 (6.5.1) | Conducted Emission                            | < 43+10log <sub>10</sub> (P[Watts]) | PASS   | -                                          |
| 3.6            | §2.1053<br>§22.917(a)<br>§24.238(a) | RSS-132 (4.5.1)<br>RSS-133 (6.5.1) | Field Strength of Spurious Radiation          | < 43+10log <sub>10</sub> (P[Watts]) | PASS   | Under limit<br>19.23 dB at<br>13156.00 MHz |
| 3.7            | §2.1055<br>§22.355<br>§24.235       | RSS-132(4.3)<br>RSS-133(6.3)       | Frequency Stability for Temperature & Voltage | < 2.5 ppm                           | PASS   | -                                          |

# 1 General Description

## 1.1 Applicant

HTC Corporation  
No. 23, Xinghua Rd., Taoyuan City, Taiwan

## 1.2 Manufacturer

HTC Corporation  
1F., No. 6-3, Baoqiang Rd., Xindian City, Taipei, Taiwan

## 1.3 Feature of Equipment Under Test

| Product Feature & Specification |                                                                                                                                                                                                                      |
|---------------------------------|----------------------------------------------------------------------------------------------------------------------------------------------------------------------------------------------------------------------|
| Equipment                       | Smartphone                                                                                                                                                                                                           |
| Model Name                      | PD42100                                                                                                                                                                                                              |
| FCC ID                          | NM8PD42100                                                                                                                                                                                                           |
| Sample 1                        | DUT with LCM-Main and Camera-Main                                                                                                                                                                                    |
| Sample 2                        | DUT with LCM-2 <sup>nd</sup> and Camera-2 <sup>nd</sup>                                                                                                                                                              |
| Tx Frequency                    | CDMA2000 BC0 : 824 MHz ~ 849 MHz<br>CDMA2000 BC1 : 1850 MHz ~1910 MHz                                                                                                                                                |
| Rx Frequency                    | CDMA2000 BC0 : 869 MHz ~ 894 MHz<br>CDMA2000 BC1 : 1930 MHz ~ 1990 MHz                                                                                                                                               |
| Maximum Output Power to Antenna | CDMA2000 BC0 : 24.78 dBm<br>CDMA2000 BC1 : 24.65 dBm                                                                                                                                                                 |
| Maximum ERP/EIRP                | <Sample 1><br>CDMA2000 BC0 (RC3+SO32): 0.11 W (20.38 dBm)<br>CDMA2000 BC1 (RC3+SO55): 0.23 W (23.59 dBm)<br><Sample 2><br>CDMA2000 BC0 (RC3+SO32): 0.09 W (19.72 dBm)<br>CDMA2000 BC1 (RC3+SO55): 0.23 W (23.55 dBm) |
| Antenna Type                    | Fixed Internal Antenna                                                                                                                                                                                               |
| Type of Modulation              | QPSK                                                                                                                                                                                                                 |
| Type of Emission                | 1M27F9W                                                                                                                                                                                                              |
| EUT Stage                       | Production Unit                                                                                                                                                                                                      |

**Remark:**

1. For other wireless features of this EUT, the test report will be issued separately.
2. This test report recorded only product characteristics and test results of PCS Licensed Transmitter Held to Ear (PCE).
3. The above EUT's information was declared by manufacturer. Please refer to the specifications or user's manual for more detailed description.

## 1.4 Testing Site

|                           |                                                                                                                                                                 |           |                                |
|---------------------------|-----------------------------------------------------------------------------------------------------------------------------------------------------------------|-----------|--------------------------------|
| <b>Test Site</b>          | SPORTON INTERNATIONAL INC.                                                                                                                                      |           |                                |
| <b>Test Site Location</b> | No. 52, Hwa Ya 1 <sup>st</sup> Rd., Hwa Ya Technology Park,<br>Kwei-Shan Hsiang, Tao Yuan Hsien, Taiwan, R.O.C.<br>TEL: +886-3-327-3456<br>FAX: +886-3-328-4978 |           |                                |
| <b>Test Site No.</b>      | <b>Sporton Site No.</b>                                                                                                                                         |           | <b>FCC/IC Registration No.</b> |
|                           | TH02-HY                                                                                                                                                         | 03CH07-HY | TW1022/4086B-1                 |

## 1.5 Applied Standards

According to the specifications of the manufacturer, the EUT must comply with the requirements of the following standards:

- ♦ Preliminary Guidance for Receiving Applications for Certification of 3G Device. May 9, 2006.
- ♦ FCC 47 CFR Part 2, 22(H), 24(E)
- ♦ ANSI / TIA / EIA-603-C-2004
- ♦ IC RSS-132 Issue 2
- ♦ IC RSS-133 Issue 5

**Remark:**

1. All test items were verified and recorded according to the standards and without any deviation during the test.
2. This EUT has also been tested and complied with the requirements of FCC Part 15, Subpart B (DoC), recorded in a separate test report.

## 1.6 Ancillary Equipment List

| Item | Equipment        | Trade Name | Model No. | FCC ID | Data Cable | Power Cord        |
|------|------------------|------------|-----------|--------|------------|-------------------|
| 1.   | System Simulator | R&S        | CMU 200   | N/A    | N/A        | Unshielded, 1.8 m |
| 2.   | Earphone         | N/A        | HS G235   | N/A    | N/A        | N/A               |

## 2 Test Configuration of Equipment Under Test

### 2.1 Test Mode

During all testing, EUT is in link mode with base station emulator at maximum power level. The spurious emission measurements were carried out in semi-anechoic chamber with 3-meter test range, and EUT is rotated on three test planes to find out the worst emission.

Frequency range investigated for radiated emission is as follows:

1. 30 MHz to 9000 MHz for CDMA2000 BC0.
2. 30 MHz to 19000 MHz for CDMA2000 BC1.

| Test Modes   |                                                                                                                                                                                                                                  |                                                                     |
|--------------|----------------------------------------------------------------------------------------------------------------------------------------------------------------------------------------------------------------------------------|---------------------------------------------------------------------|
| Band         | Radiated TCs                                                                                                                                                                                                                     | Conducted TCs                                                       |
| CDMA2000 BC0 | <ul style="list-style-type: none"> <li>■ 1xRTT Link Mode for Sample 1 + Battery 1 + USB Cable 1 (Charging from Adapter 1)</li> <li>■ 1xRTT Link Mode for Sample 2 + Battery 1 + USB Cable 1 (Charging from Adapter 1)</li> </ul> | <ul style="list-style-type: none"> <li>■ 1xRTT Link Mode</li> </ul> |
| CDMA2000 BC1 | <ul style="list-style-type: none"> <li>■ 1xRTT Link Mode for Sample 1 + Battery 1 + USB Cable 1 (Charging from Adapter 1)</li> <li>■ 1xRTT Link Mode for Sample 2 + Battery 1 + USB Cable 1 (Charging from Adapter 1)</li> </ul> | <ul style="list-style-type: none"> <li>■ 1xRTT Link Mode</li> </ul> |

**Note:**

1. The maximum RF output power levels are 1xRTT RC3+SO32 mode for CDMA2000 BC0 and 1xRTT RC3+SO55 mode for CDMA2000 BC1 on QPSK Link; only these modes were used for all tests.
2. Because there are individual antennas for each WWAN, WLAN, and Bluetooth, the co-location test modes are not required.

The conducted power table is as follows:

| Conducted Power (*Unit: dBm) |              |        |        |              |       |         |
|------------------------------|--------------|--------|--------|--------------|-------|---------|
| Band                         | CDMA2000 BC0 |        |        | CDMA2000 BC1 |       |         |
| Channel                      | 1013         | 384    | 777    | 25           | 600   | 1175    |
| Frequency                    | 824.7        | 836.52 | 848.31 | 1851.25      | 1880  | 1908.75 |
| 1xRTT RC1+SO55               | 24.74        | 24.62  | 24.64  | 24.62        | 24.56 | 24.48   |
| 1xRTT RC3+SO55               | 24.74        | 24.67  | 24.72  | <b>24.65</b> | 24.52 | 24.47   |
| 1xRTT RC3+SO32 (FCH)         | <b>24.78</b> | 24.63  | 24.66  | 24.58        | 24.57 | 24.44   |
| 1xRTT RC3+SO32 (SCH)         | 24.76        | 24.66  | 24.70  | 24.59        | 24.57 | 24.41   |
| 1xEVDO RTAP 153.6            | 24.71        | 24.65  | 24.74  | 24.63        | 24.60 | 24.44   |
| 1xEVDO RETAP 4096            | 24.72        | 24.65  | 24.75  | 24.64        | 24.53 | 24.51   |

## 2.2 Connection Diagram of Test System

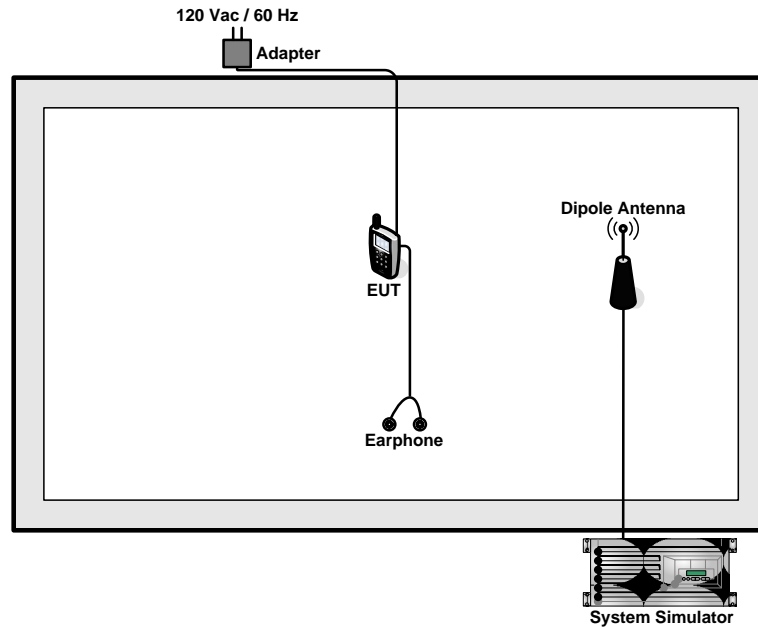



### 3 Test Result

#### 3.1 Conducted Output Power Measurement

##### 3.1.1 Description of the Conducted Output Power Measurement

A base station simulator was used to establish communication with the EUT. Its parameters were set to transmit the maximum power on the EUT. The measured power in the radio frequency on the transmitter output terminals shall be reported.

##### 3.1.2 Measuring Instruments

See list of measuring instruments of this test report.

##### 3.1.3 Test Procedures

1. The transmitter output port was connected to base station.
2. Set EUT at maximum power through base station.
3. Select lowest, middle, and highest channels for each band and different modulation.

##### 3.1.4 Test Setup

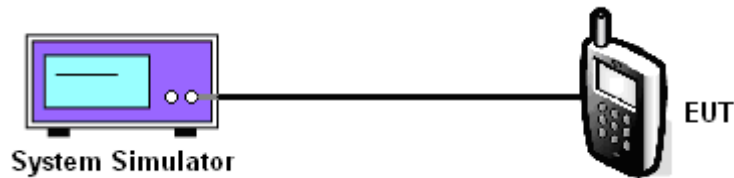



3.1.5 Test Result of Conducted Output Power

| CDMA2000 BC0      |             |            |                 |                       |                         |
|-------------------|-------------|------------|-----------------|-----------------------|-------------------------|
| Test Mode         | Test Status | Channel    | Frequency (MHz) | Conducted Power (dBm) | Conducted Power (Watts) |
| CDMA2000<br>1xRTT | RC3+SO32    | 1013 (Low) | 824.70          | 24.78                 | 0.30                    |
|                   |             | 384 (Mid)  | 836.52          | 24.63                 | 0.29                    |
|                   |             | 777 (High) | 848.31          | 24.66                 | 0.30                    |

| CDMA2000 BC1      |             |             |                 |                       |                         |
|-------------------|-------------|-------------|-----------------|-----------------------|-------------------------|
| Test Mode         | Test Status | Channel     | Frequency (MHz) | Conducted Power (dBm) | Conducted Power (Watts) |
| CDMA2000<br>1xRTT | RC3+SO55    | 25 (Low)    | 1851.25         | 24.65                 | 0.29                    |
|                   |             | 600 (Mid)   | 1880.00         | 24.52                 | 0.29                    |
|                   |             | 1175 (High) | 1908.75         | 24.47                 | 0.28                    |

## 3.2 Effective Radiated Power and Effective Isotropic Radiated Power Measurement

### 3.2.1 Description of the ERP/EIRP Measurement

ERP/EIRP is measured by substitution method according to ANSI / TIA / EIA-603-C-2004. The ERP of mobile transmitters must not exceed 7 Watts and the EIRP of mobile transmitters are limited to 2 Watts.

### 3.2.2 Measuring Instruments

See list of measuring instruments of this test report.

### 3.2.3 Test Procedures

1. The EUT was placed on a turntable with 1.0 meter height in a fully anechoic chamber.
2. The EUT was set at 1.2 meters from the receiving antenna, which was mounted on the antenna tower.
3. The table was rotated 360 degrees to determine the position of the highest radiated power.
4. The height of the receiving antenna is adjusted to look for the maximum ERP/EIRP.
5. Taking the record of maximum ERP/EIRP.
6. A dipole antenna was substituted in place of the EUT and was driven by a signal generator.
7. The conducted power at the terminal of the dipole antenna is measured.
8. Repeat step 3 to step 5 to get the maximum ERP/EIRP of the substitution antenna.
9.  $ERP/EIRP = P_s + E_t - E_s + G_s = P_s + R_t - R_s + G_s$

$P_s$  (dBm) : Input power to substitution antenna.

$G_s$  (dBi or dBd) : Substitution antenna Gain.

$E_t = R_t + AF$

$E_s = R_s + AF$

AF (dB/m) : Receive antenna factor

$R_t$  : The highest received signal in spectrum analyzer for EUT.

$R_s$  : The highest received signal in spectrum analyzer for substitution antenna.

### 3.2.4 Test Setup

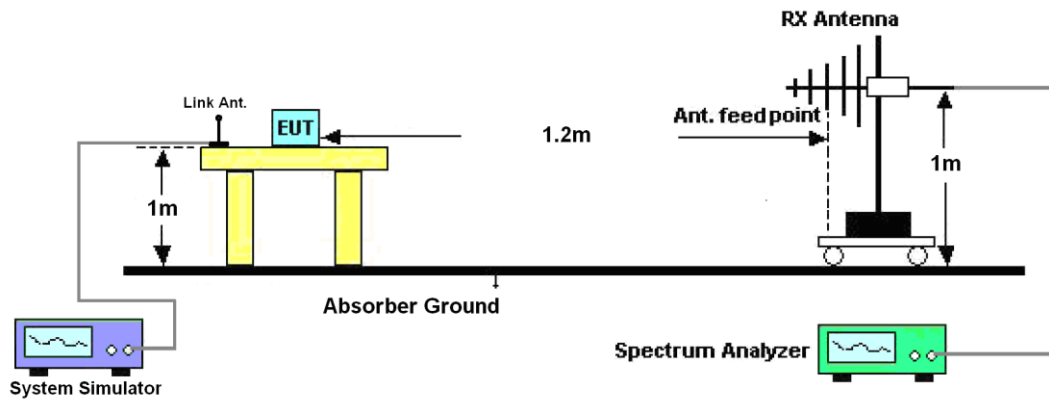



3.2.5 Test Result of ERP

| CDMA2000 BC0 1xRTT_RC3+SO32 Radiated Power ERP for Sample 1 |          |          |          |          |           |         |
|-------------------------------------------------------------|----------|----------|----------|----------|-----------|---------|
| Horizontal Polarization                                     |          |          |          |          |           |         |
| Frequency (MHz)                                             | Rt (dBm) | Rs (dBm) | Ps (dBm) | Gs (dBd) | ERP (dBm) | ERP (W) |
| 824.70                                                      | -27.70   | -48.12   | 0.00     | -1.08    | 19.34     | 0.09    |
| 836.52                                                      | -26.97   | -48.28   | 0.00     | -0.93    | 20.38     | 0.11    |
| 848.31                                                      | -27.71   | -48.35   | 0.00     | -0.76    | 19.88     | 0.10    |
| Vertical Polarization                                       |          |          |          |          |           |         |
| Frequency (MHz)                                             | Rt (dBm) | Rs (dBm) | Ps (dBm) | Gs (dBd) | ERP (dBm) | ERP (W) |
| 824.70                                                      | -41.11   | -47.97   | 0.00     | -1.08    | 5.78      | 0.00    |
| 836.52                                                      | -40.60   | -48.01   | 0.00     | -0.93    | 6.48      | 0.00    |
| 848.31                                                      | -40.62   | -48.05   | 0.00     | -0.76    | 6.67      | 0.00    |

| CDMA2000 BC0 1xRTT_RC3+SO32 Radiated Power ERP for Sample 2 |          |          |          |          |           |         |
|-------------------------------------------------------------|----------|----------|----------|----------|-----------|---------|
| Horizontal Polarization                                     |          |          |          |          |           |         |
| Frequency (MHz)                                             | Rt (dBm) | Rs (dBm) | Ps (dBm) | Gs (dBd) | ERP (dBm) | ERP (W) |
| 824.70                                                      | -27.84   | -48.12   | 0.00     | -1.08    | 19.20     | 0.08    |
| 836.52                                                      | -27.63   | -48.28   | 0.00     | -0.93    | 19.72     | 0.09    |
| 848.31                                                      | -28.30   | -48.35   | 0.00     | -0.76    | 19.29     | 0.08    |
| Vertical Polarization                                       |          |          |          |          |           |         |
| Frequency (MHz)                                             | Rt (dBm) | Rs (dBm) | Ps (dBm) | Gs (dBd) | ERP (dBm) | ERP (W) |
| 824.70                                                      | -40.84   | -47.97   | 0.00     | -1.08    | 6.05      | 0.00    |
| 836.52                                                      | -40.71   | -48.01   | 0.00     | -0.93    | 6.37      | 0.00    |
| 848.31                                                      | -41.15   | -48.05   | 0.00     | -0.76    | 6.14      | 0.00    |



3.2.6 Test Result of EIRP

| CDMA2000 BC1 1xRTT_RC3+SO55 Radiated Power EIRP for Sample 1 |          |          |          |          |            |          |
|--------------------------------------------------------------|----------|----------|----------|----------|------------|----------|
| Horizontal Polarization                                      |          |          |          |          |            |          |
| Frequency (MHz)                                              | Rt (dBm) | Rs (dBm) | Ps (dBm) | Gs (dBi) | EIRP (dBm) | EIRP (W) |
| 1851.25                                                      | -30.59   | -51.88   | 0.00     | 1.96     | 23.25      | 0.21     |
| 1880.00                                                      | -31.45   | -52.99   | 0.00     | 2.00     | 23.54      | 0.23     |
| 1908.75                                                      | -32.67   | -54.28   | 0.00     | 1.98     | 23.59      | 0.23     |
| Vertical Polarization                                        |          |          |          |          |            |          |
| Frequency (MHz)                                              | Rt (dBm) | Rs (dBm) | Ps (dBm) | Gs (dBi) | EIRP (dBm) | EIRP (W) |
| 1851.25                                                      | -31.04   | -52.13   | 0.00     | 1.96     | 23.05      | 0.20     |
| 1880.00                                                      | -32.00   | -53.17   | 0.00     | 2.00     | 23.17      | 0.21     |
| 1908.75                                                      | -32.84   | -54.13   | 0.00     | 1.98     | 23.27      | 0.21     |

| CDMA2000 BC1 1xRTT_RC3+SO55 Radiated Power EIRP for Sample 2 |          |          |          |          |            |          |
|--------------------------------------------------------------|----------|----------|----------|----------|------------|----------|
| Horizontal Polarization                                      |          |          |          |          |            |          |
| Frequency (MHz)                                              | Rt (dBm) | Rs (dBm) | Ps (dBm) | Gs (dBi) | EIRP (dBm) | EIRP (W) |
| 1851.25                                                      | -31.26   | -51.88   | 0.00     | 1.96     | 22.58      | 0.18     |
| 1880.00                                                      | -31.82   | -52.99   | 0.00     | 2.00     | 23.17      | 0.21     |
| 1908.75                                                      | -32.71   | -54.28   | 0.00     | 1.98     | 23.55      | 0.23     |
| Vertical Polarization                                        |          |          |          |          |            |          |
| Frequency (MHz)                                              | Rt (dBm) | Rs (dBm) | Ps (dBm) | Gs (dBi) | EIRP (dBm) | EIRP (W) |
| 1851.25                                                      | -31.67   | -52.13   | 0.00     | 1.96     | 22.42      | 0.17     |
| 1880.00                                                      | -32.41   | -53.17   | 0.00     | 2.00     | 22.76      | 0.19     |
| 1908.75                                                      | -32.95   | -54.13   | 0.00     | 1.98     | 23.16      | 0.21     |

### 3.3 Occupied Bandwidth Measurement

#### 3.3.1 Description of Occupied Bandwidth Measurement

The emission bandwidth is defined as the width of the signal between two points, located at the 2 sides of the carrier frequency, outside of which all emissions are attenuated at least 26 dB below the transmitter power.

#### 3.3.2 Measuring Instruments

See list of measuring instruments of this test report.

#### 3.3.3 Test Procedures

1. The EUT was connected to Spectrum Analyzer and Base Station via power divider.
2. The 99% and 26 dB occupied bandwidth (BW) of the middle channel for the highest RF powers were measured.

#### 3.3.4 Test Setup

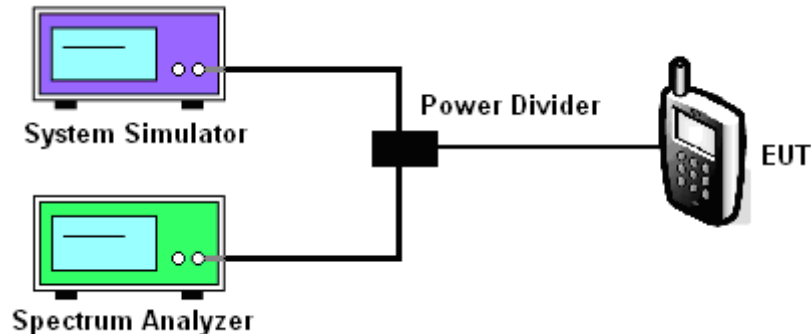



### 3.3.5 Test Result (Plots) of Occupied Bandwidth

|                    |                |                      |      |
|--------------------|----------------|----------------------|------|
| <b>Band :</b>      | CDMA2000 BC0   | <b>Power Stage :</b> | High |
| <b>Test Mode :</b> | 1xRTT_RC3+SO32 |                      |      |

#### 99% Occupied Bandwidth Plot on Channel 384

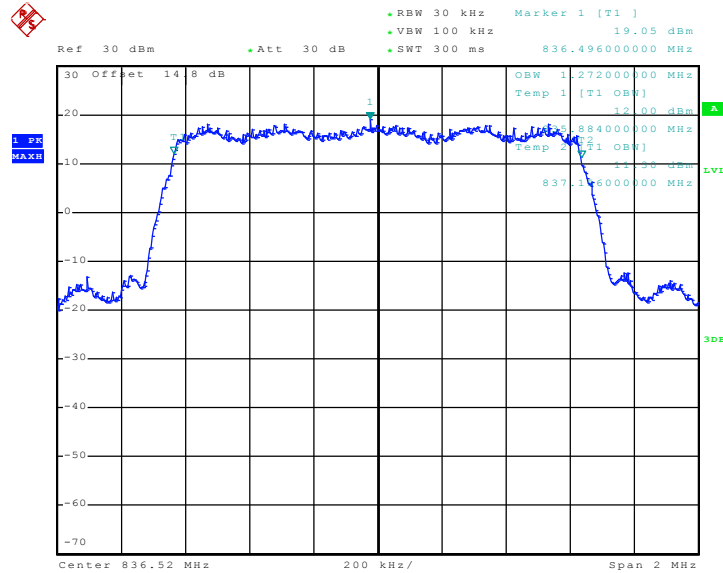

Date: 5.AUG.2010 10:18:05

#### 26dB Bandwidth Plot on Channel 384

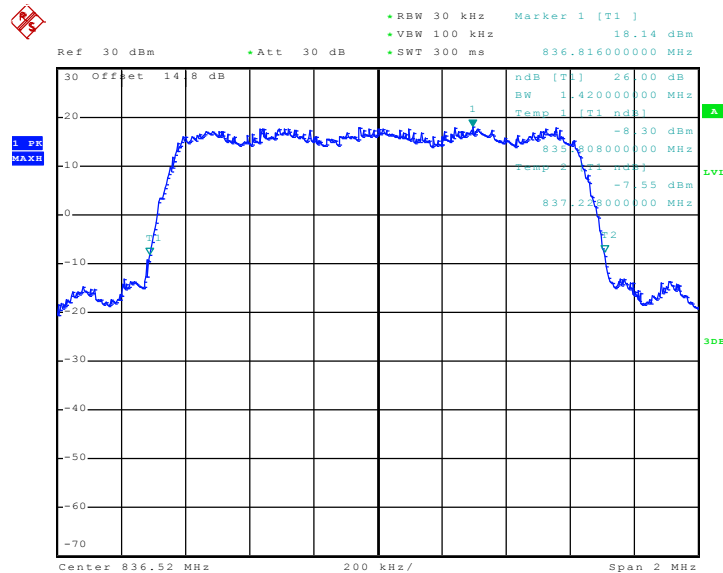

Date: 5.AUG.2010 10:14:45





|                    |                |                      |      |
|--------------------|----------------|----------------------|------|
| <b>Band :</b>      | CDMA2000 BC1   | <b>Power Stage :</b> | High |
| <b>Test Mode :</b> | 1xRTT_RC3+SO55 |                      |      |

99% Occupied Bandwidth Plot on Channel 600

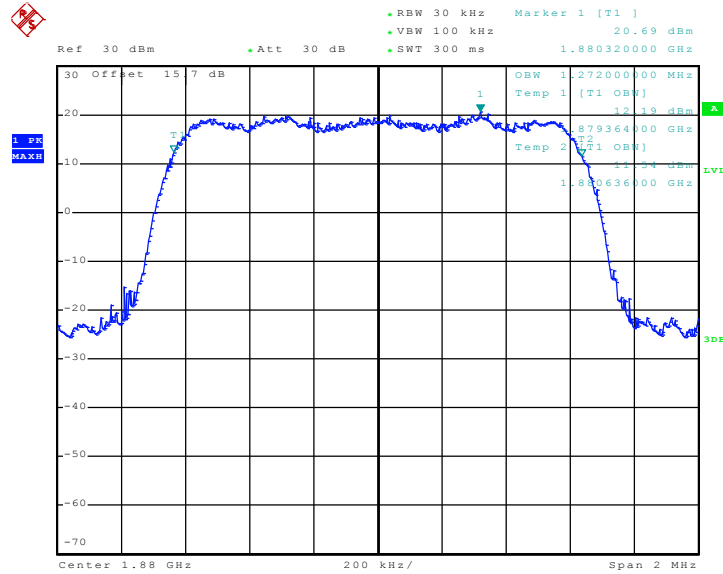

Date: 5.AUG.2010 11:28:05

26dB Bandwidth Plot on Channel 600

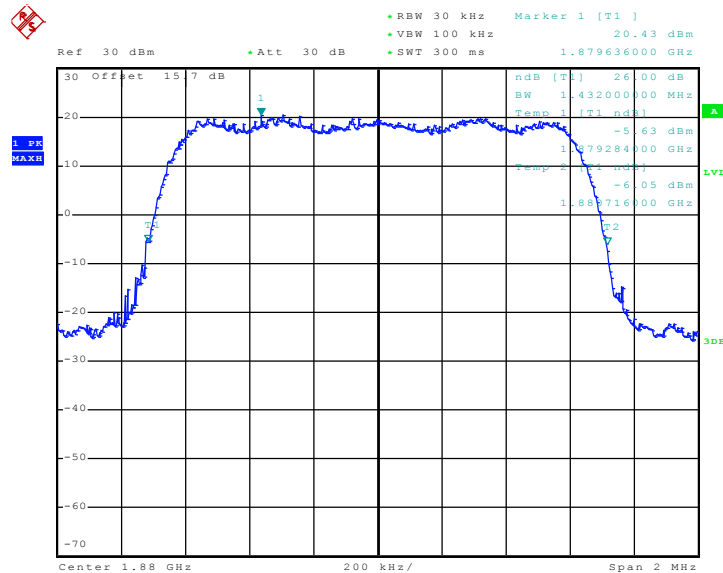

Date: 5.AUG.2010 11:22:36

## 3.4 Band Edge Measurement

### 3.4.1 Description of Band Edge Measurement

The power of any emission outside of the authorized operating frequency ranges must be lower than the transmitter power (P) by a factor of at least  $43 + 10 \log (P)$  dB.

### 3.4.2 Measuring Instruments

See list of measuring instruments of this test report.

### 3.4.3 Test Procedures

1. The EUT was connected to Spectrum Analyzer and Base Station via power divider.
2. The band edges of low and high channels for the highest RF powers were measured. Setting RBW as roughly  $BW/100$ .
3. The RBW was replaced by 10 kHz, due to the spectrum analyzer IF-Filter including an excess of the limit. A worst case correction factor of  $10 \log (1\% BW/\text{measurement RBW})$  was implemented.

### 3.4.4 Test Setup

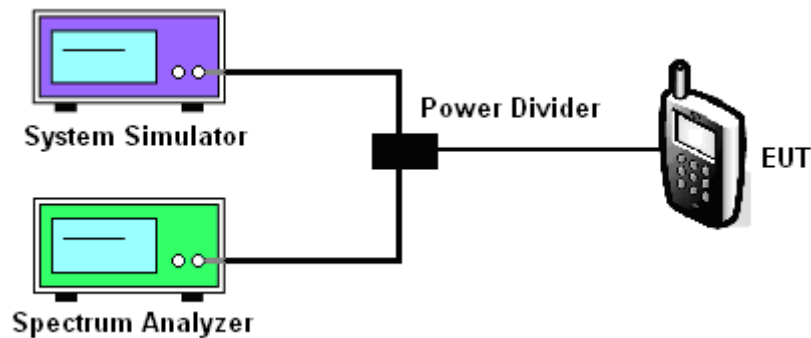



### 3.4.5 Test Result (Plots) of Conducted Band Edge

|             |                |               |      |
|-------------|----------------|---------------|------|
| Band :      | CDMA2000 BC0   | Power Stage : | High |
| Test Mode : | 1xRTT_RC3+SO32 |               |      |

Lower Band Edge Plot on Channel 1013

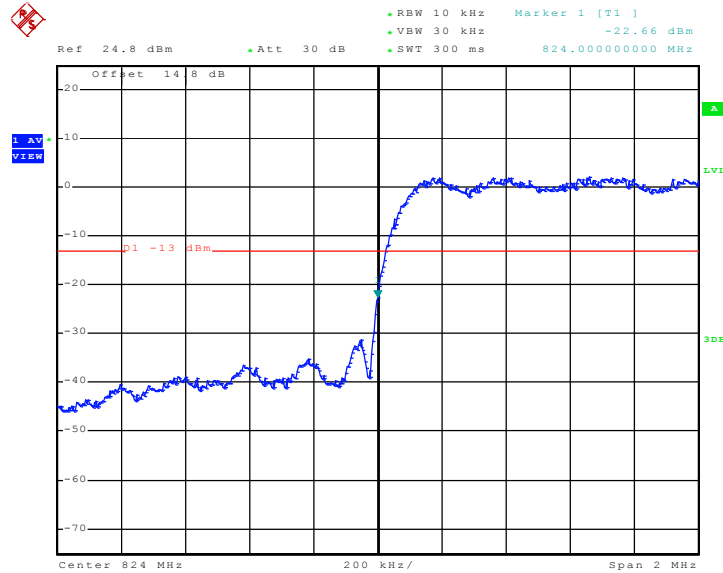

Date: 5.AUG.2010 14:16:47

Higher Band Edge Plot on Channel 777

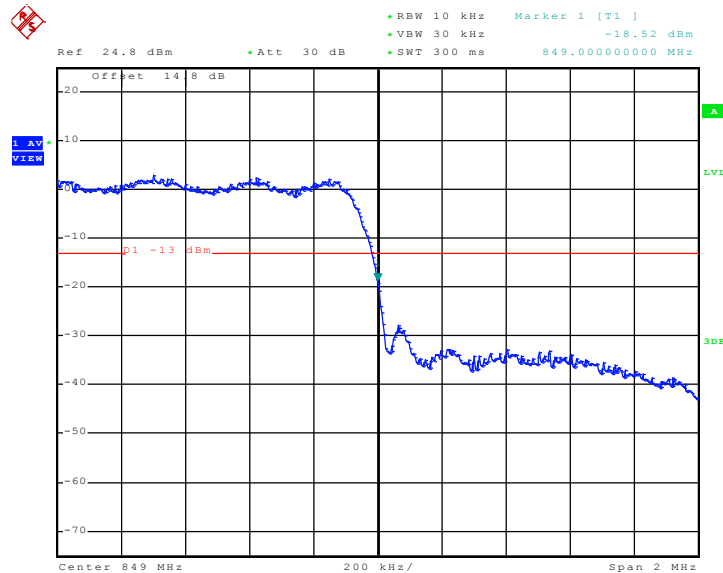

Date: 5.AUG.2010 14:17:31



|             |                |               |      |
|-------------|----------------|---------------|------|
| Band :      | CDMA2000 BC1   | Power Stage : | High |
| Test Mode : | 1xRTT_RC3+SO55 |               |      |

Lower Band Edge Plot on Channel 25

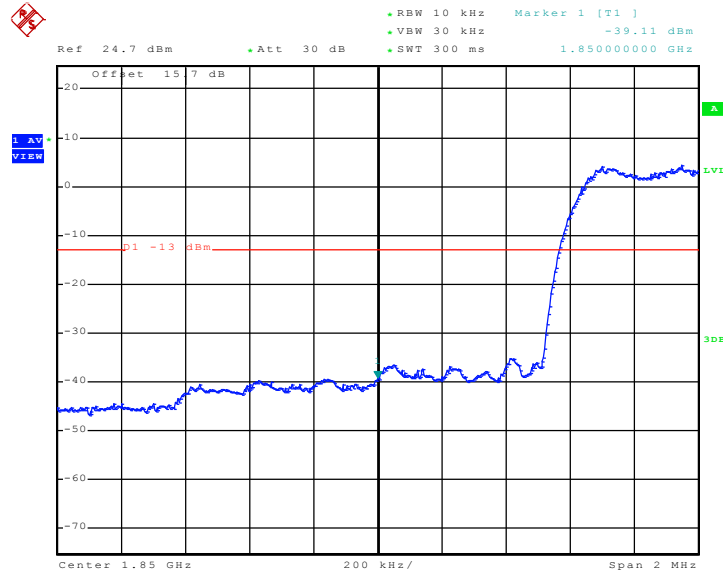

Date: 5.AUG.2010 11:49:05

Higher Band Edge Plot on Channel 1175

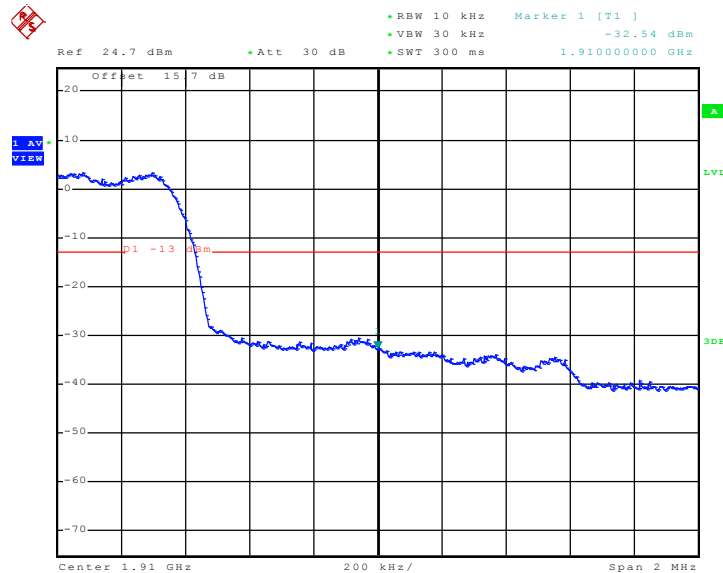

Date: 5.AUG.2010 11:44:20

## 3.5 Conducted Emission Measurement

### 3.5.1 Description of Conducted Emission Measurement

The power of any emission outside of the authorized operating frequency ranges must be lower than the transmitter power (P) by a factor of at least  $43 + 10 \log (P)$  dB.

It is measured by means of a calibrated spectrum analyzer and scanned from 30 MHz up to a frequency including its 10<sup>th</sup> harmonic.

### 3.5.2 Measuring Instruments

See list of measuring instruments of this test report.

### 3.5.3 Test Procedures

1. The EUT was connected to spectrum analyzer and base station via power divider.
2. The middle channel for the highest RF power within the transmitting frequency was measured.
3. The conducted spurious emission for the whole frequency range was taken.

### 3.5.4 Test Setup

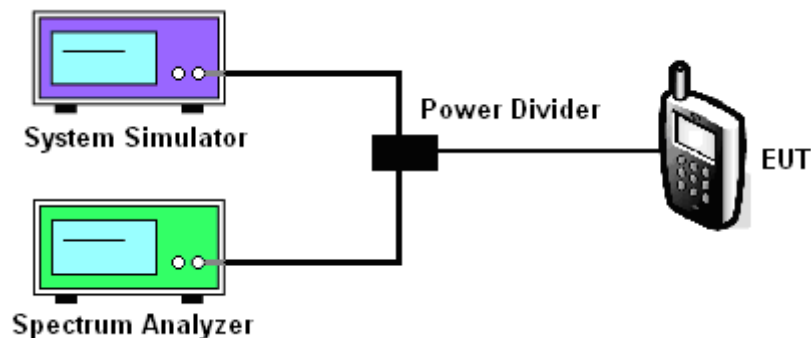

### 3.5.5 Test Result (Plots) of Conducted Emission

|                    |                |                      |      |
|--------------------|----------------|----------------------|------|
| <b>Band :</b>      | CDMA2000 BC0   | <b>Power Stage :</b> | High |
| <b>Test Mode :</b> | 1xRTT_RC3+SO32 |                      |      |

Conducted Emission Plot between 30MHz ~ 1GHz

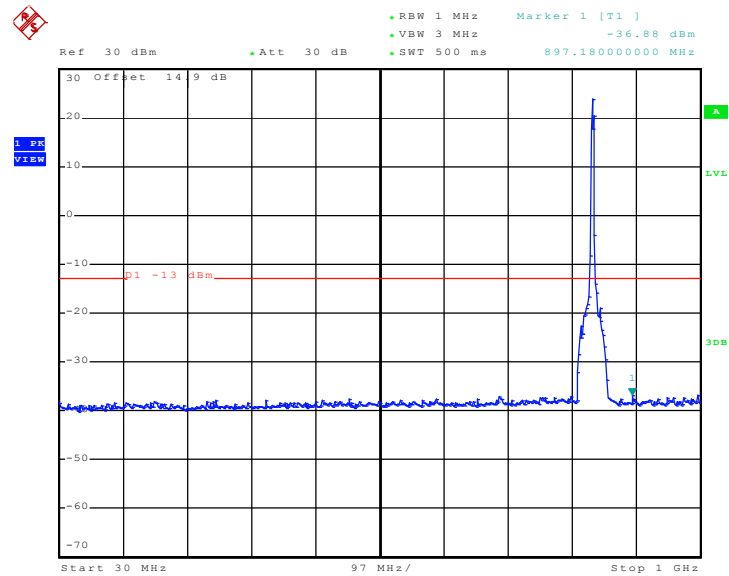

Date: 5.AUG.2010 15:10:27

Conducted Emission Plot between 1GHz ~ 3GHz

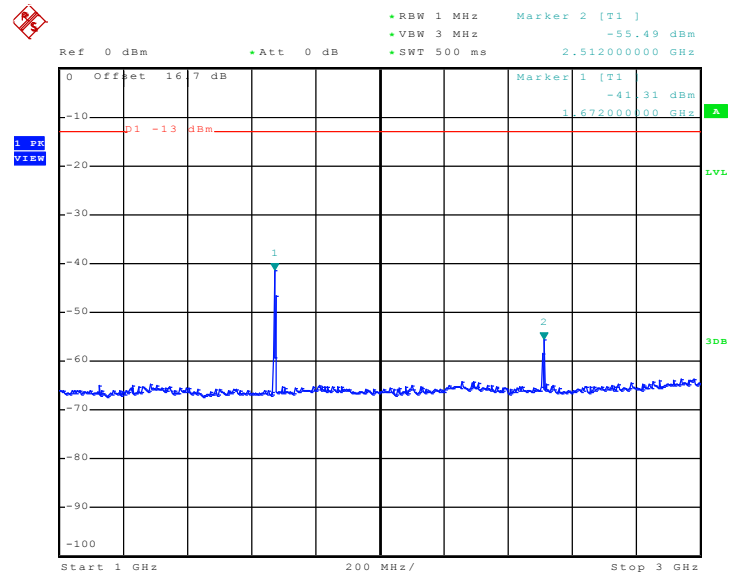

Date: 5.AUG.2010 15:20:56



### Conducted Emission Plot between 3GHz ~ 7GHz

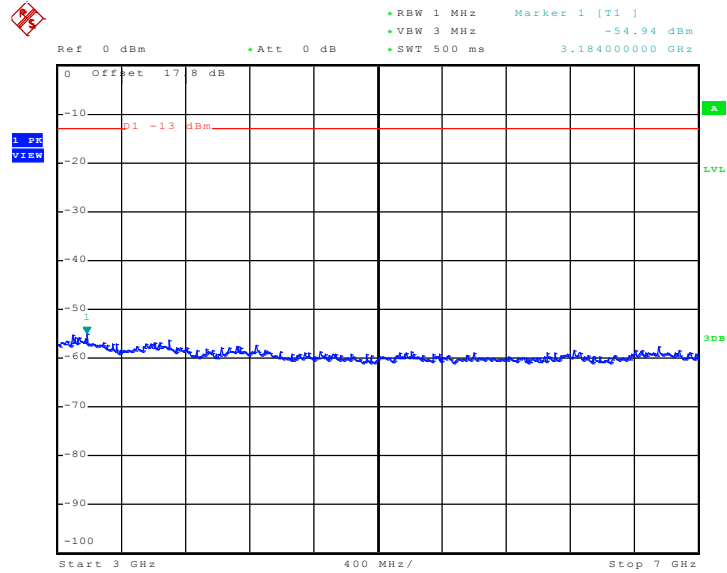

Date: 5.AUG.2010 15:18:23

### Conducted Emission Plot between 7GHz ~ 9GHz

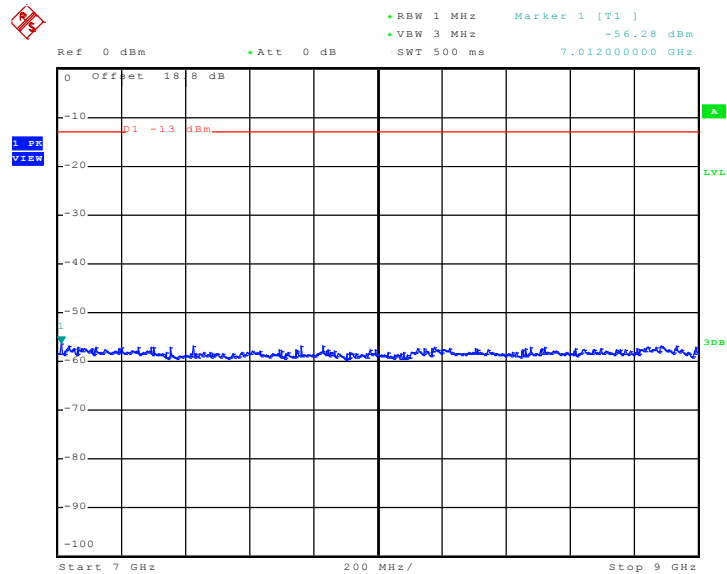

Date: 5.AUG.2010 15:16:46



|                    |                |                      |      |
|--------------------|----------------|----------------------|------|
| <b>Band :</b>      | CDMA2000 BC1   | <b>Power Stage :</b> | High |
| <b>Test Mode :</b> | 1xRTT_RC3+SO55 |                      |      |

Conducted Emission Plot between 30MHz ~ 1GHz

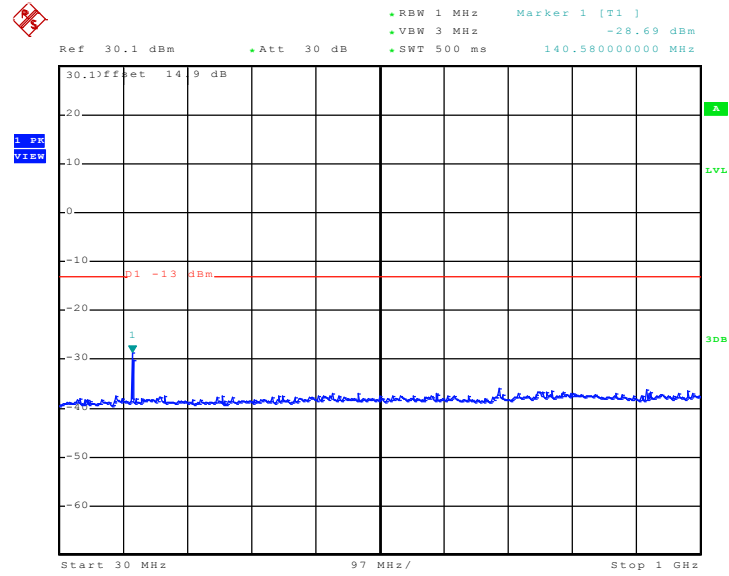

Date: 5.AUG.2010 14:47:24

Conducted Emission Plot between 1GHz ~ 3GHz

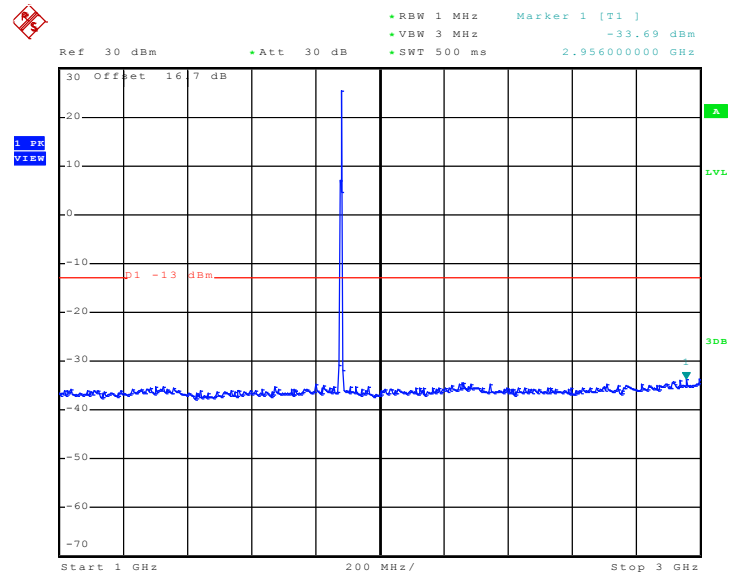

Date: 5.AUG.2010 14:58:28





### Conducted Emission Plot between 3GHz ~ 7GHz

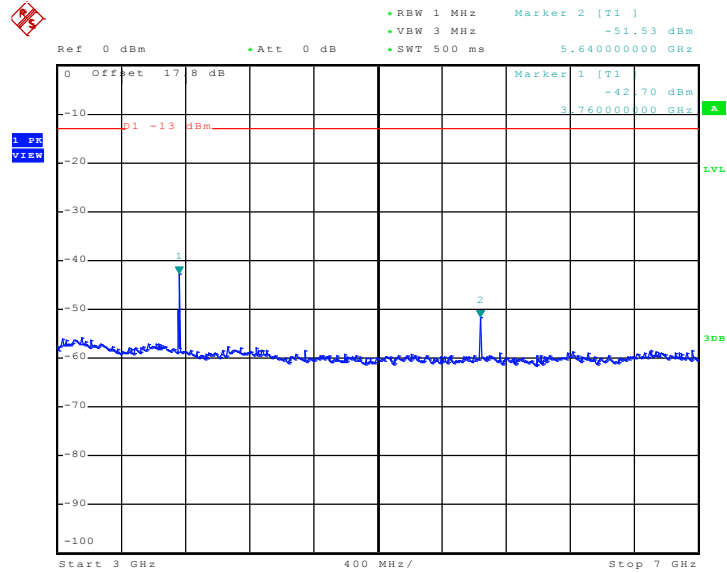

Date: 5.AUG.2010 15:23:41

### Conducted Emission Plot between 7GHz ~ 13.6GHz

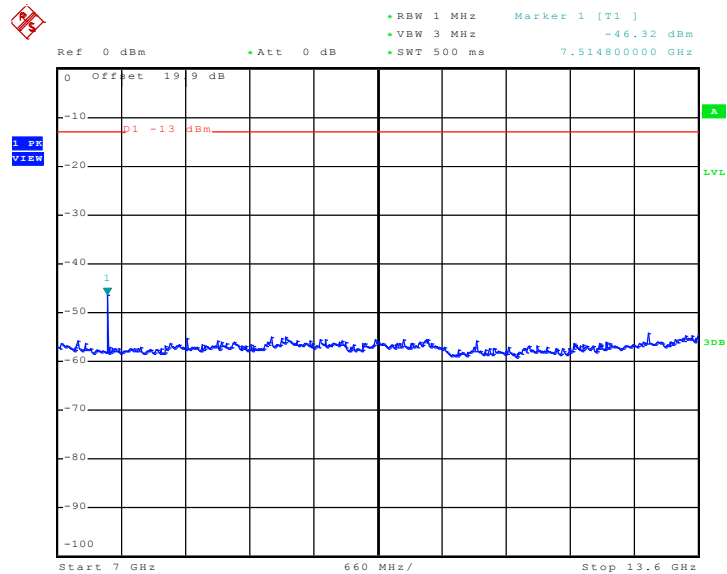

Date: 5.AUG.2010 15:25:24



Conducted Emission Plot between 13.6GHz ~ 19.1GHz

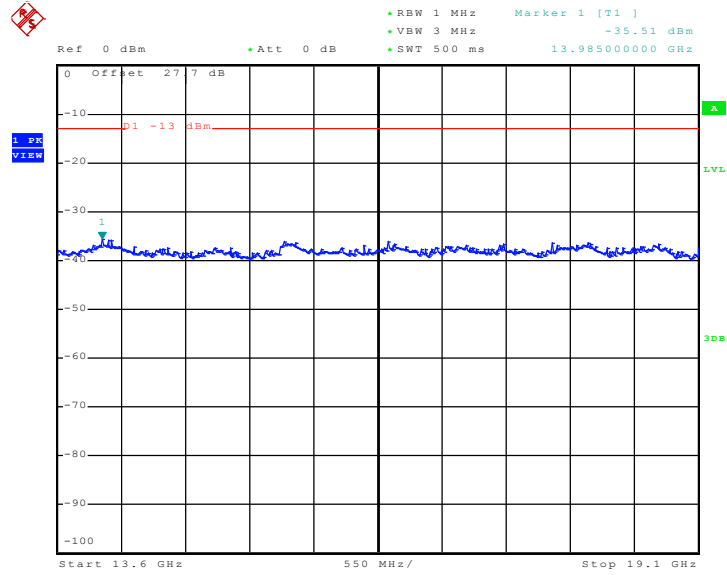

Date: 5.AUG.2010 15:27:01

## 3.6 Field Strength of Spurious Radiation Measurement

### 3.6.1 Description of Field Strength of Spurious Radiated Measurement

The radiated spurious emission was measured by substitution method according to ANSI / TIA / EIA-603-C-2004. The power of any emission outside of the authorized operating frequency ranges must be attenuated below the transmitter power (P) by a factor of at least  $43+10\log_{10}(P[\text{Watts}])$  dB. The spectrum is scanned from 30 MHz up to a frequency including its 10th harmonic.

### 3.6.2 Measuring Instruments

See list of measuring instruments of this test report.

### 3.6.3 Test Procedures

1. The EUT was placed on a rotatable wooden table with 0.8 meter about ground.
2. The EUT was set 3 meters from the receiving antenna, which was mounted on the antenna tower.
3. The table was rotated 360 degrees to determine the position of the highest spurious emission.
4. The height of the receiving antenna is varied between one meter and four meters to search the maximum spurious emission for both horizontal and vertical polarizations.
5. Make the measurement with the spectrum analyzer's RBW = 1MHz, VBW = 3MHz, Sweep = 500ms, Taking the record of maximum spurious emission.
6. A horn antenna was substituted in place of the EUT and was driven by a signal generator.
7. Tune the output power of signal generator to the same emission level with EUT maximum spurious emission.
8. Taking the record of output power at antenna port.
9. Repeat step 7 to step 8 for another polarization.
10.  $\text{EIRP (dBm)} = \text{S.G. Power} - \text{Tx Cable Loss} + \text{Tx Antenna Gain}$
11.  $\text{ERP (dBm)} = \text{EIRP} - 2.15$

### 3.6.4 Test Setup

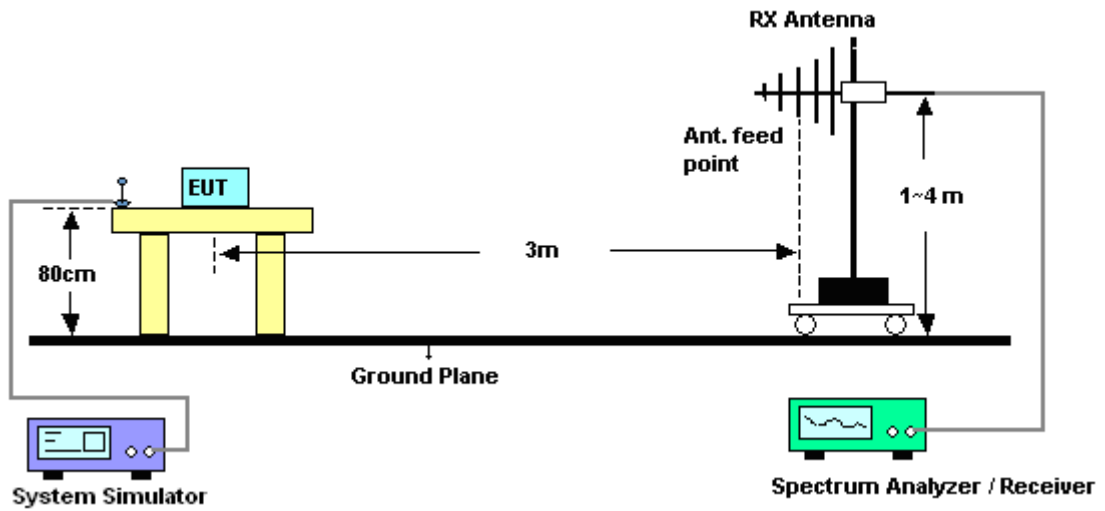



3.6.5 Test Result of Field Strength of Spurious Radiated

|                        |                                                                                  |                            |            |
|------------------------|----------------------------------------------------------------------------------|----------------------------|------------|
| <b>Band :</b>          | CDMA2000 BC0                                                                     | <b>Temperature :</b>       | 28~29°C    |
| <b>Test Mode :</b>     | 1xRTT_RC3+SO32 for Sample 1                                                      | <b>Relative Humidity :</b> | 41~43%     |
| <b>Test Engineer :</b> | Kay Wu                                                                           | <b>Polarization :</b>      | Horizontal |
| <b>Remark :</b>        | Spurious emissions within 30-1000MHz were found more than 20dB below limit line. |                            |            |

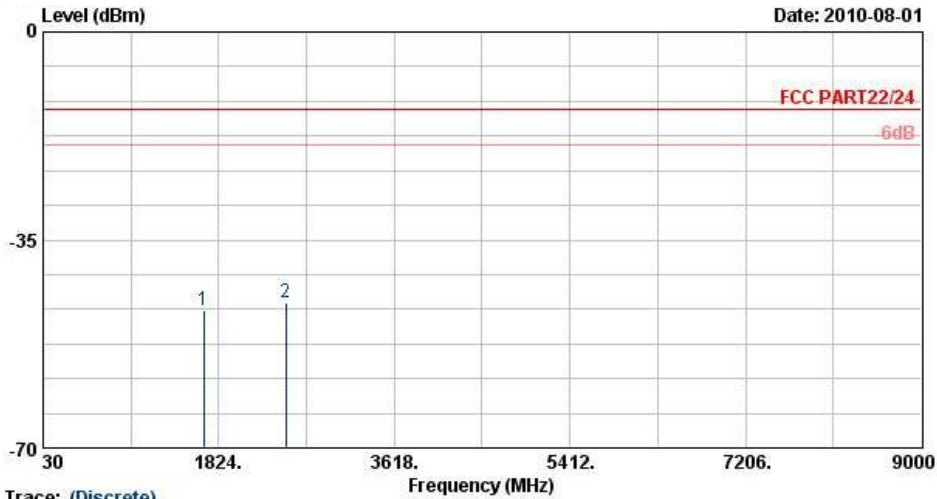

Trace: (Discrete)  
 Site : 03CH07-RY  
 Condition : FCC PART22/24 HF-ETRP(080306) HORIZONTAL  
 Project : RG 072126

| Frequency ( MHz ) | ERP ( dBm ) | Limit ( dBm ) | Over Limit ( dB ) | SPA Reading ( dBm ) | S.G. Power ( dBm ) | TX Cable loss ( dB ) | TX Antenna Gain ( dBi ) | Polarization ( H/V ) | Result |
|-------------------|-------------|---------------|-------------------|---------------------|--------------------|----------------------|-------------------------|----------------------|--------|
| 1669              | -46.93      | -13           | -33.93            | -55.48              | -48.65             | 1.62                 | 5.49                    | H                    | Pass   |
| 2509              | -45.64      | -13           | -32.64            | -57.9               | -47.61             | 2.1                  | 6.22                    | H                    | Pass   |



|                        |                                                                                  |                            |          |
|------------------------|----------------------------------------------------------------------------------|----------------------------|----------|
| <b>Band :</b>          | CDMA2000 BC0                                                                     | <b>Temperature :</b>       | 28~29°C  |
| <b>Test Mode :</b>     | 1xRTT_RC3+SO32 for Sample 1                                                      | <b>Relative Humidity :</b> | 41~43%   |
| <b>Test Engineer :</b> | Kay Wu                                                                           | <b>Polarization :</b>      | Vertical |
| <b>Remark :</b>        | Spurious emissions within 30-1000MHz were found more than 20dB below limit line. |                            |          |

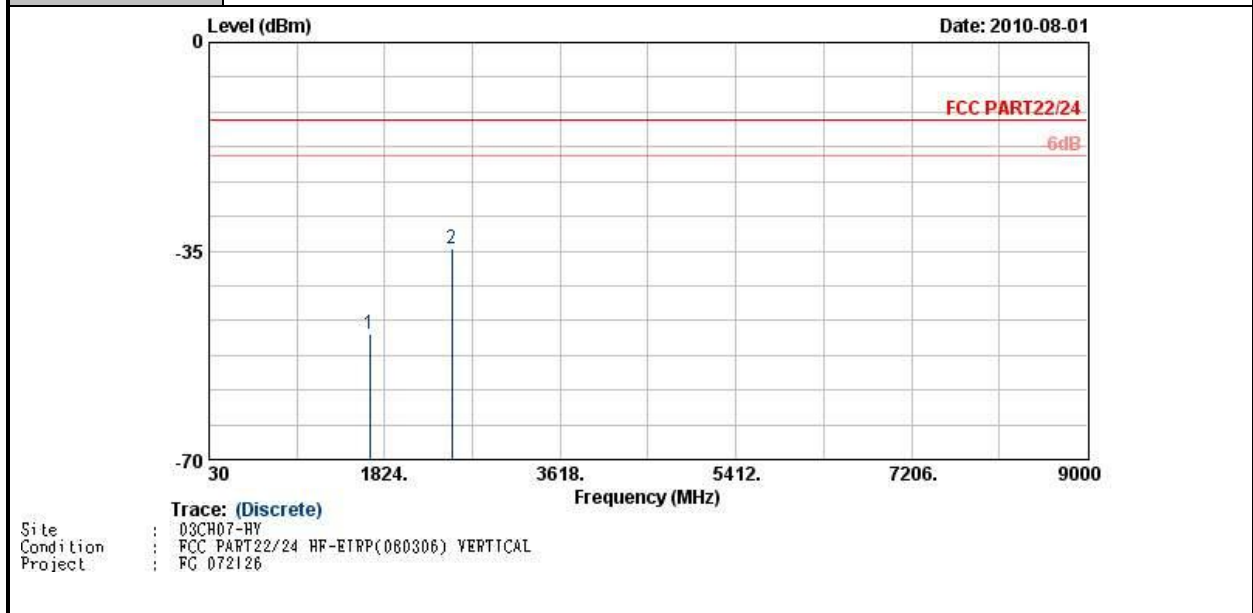

| Frequency (MHz) | ERP (dBm) | Limit (dBm) | Over Limit (dB) | SPA Reading (dBm) | S.G. Power (dBm) | TX Cable loss (dB) | TX Antenna Gain (dBi) | Polarization (H/V) | Result |
|-----------------|-----------|-------------|-----------------|-------------------|------------------|--------------------|-----------------------|--------------------|--------|
| 1669            | -48.90    | -13         | -35.90          | -58.19            | -50.62           | 1.62               | 5.49                  | V                  | Pass   |
| 2509            | -34.60    | -13         | -21.60          | -47.06            | -36.57           | 2.1                | 6.22                  | V                  | Pass   |



|                        |                                                                                  |                            |            |
|------------------------|----------------------------------------------------------------------------------|----------------------------|------------|
| <b>Band :</b>          | CDMA2000 BC0                                                                     | <b>Temperature :</b>       | 28~29°C    |
| <b>Test Mode :</b>     | 1xRTT_RC3+SO32 for Sample 2                                                      | <b>Relative Humidity :</b> | 41~43%     |
| <b>Test Engineer :</b> | Kay Wu                                                                           | <b>Polarization :</b>      | Horizontal |
| <b>Remark :</b>        | Spurious emissions within 30-1000MHz were found more than 20dB below limit line. |                            |            |

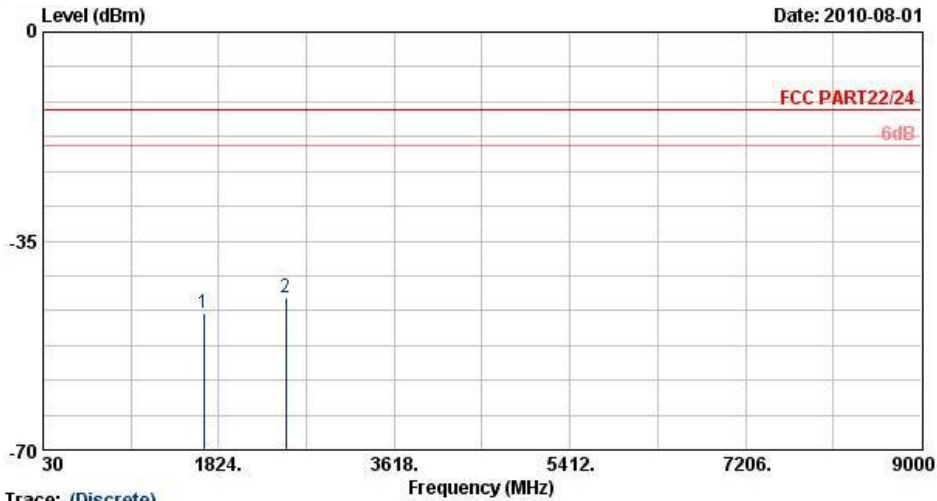

Trace: (Discrete)  
 Site : 03CH07-HY  
 Condition : FCC PART22/24 HF-EIRP(080306) HORIZONTAL  
 Project : RC 072126

| Frequency ( MHz ) | ERP ( dBm ) | Limit ( dBm ) | Over Limit ( dB ) | SPA Reading ( dBm ) | S.G. Power ( dBm ) | TX Cable loss ( dB ) | TX Antenna Gain ( dBi ) | Polarization ( H/V ) | Result |
|-------------------|-------------|---------------|-------------------|---------------------|--------------------|----------------------|-------------------------|----------------------|--------|
| 1669              | -47.04      | -13           | -34.04            | -54.29              | -48.76             | 1.62                 | 5.49                    | H                    | Pass   |
| 2509              | -44.40      | -13           | -31.40            | -55.24              | -46.37             | 2.1                  | 6.22                    | H                    | Pass   |



|                        |                                                                                  |                            |          |
|------------------------|----------------------------------------------------------------------------------|----------------------------|----------|
| <b>Band :</b>          | CDMA2000 BC0                                                                     | <b>Temperature :</b>       | 28~29°C  |
| <b>Test Mode :</b>     | 1xRTT_RC3+SO32 for Sample 2                                                      | <b>Relative Humidity :</b> | 41~43%   |
| <b>Test Engineer :</b> | Kay Wu                                                                           | <b>Polarization :</b>      | Vertical |
| <b>Remark :</b>        | Spurious emissions within 30-1000MHz were found more than 20dB below limit line. |                            |          |

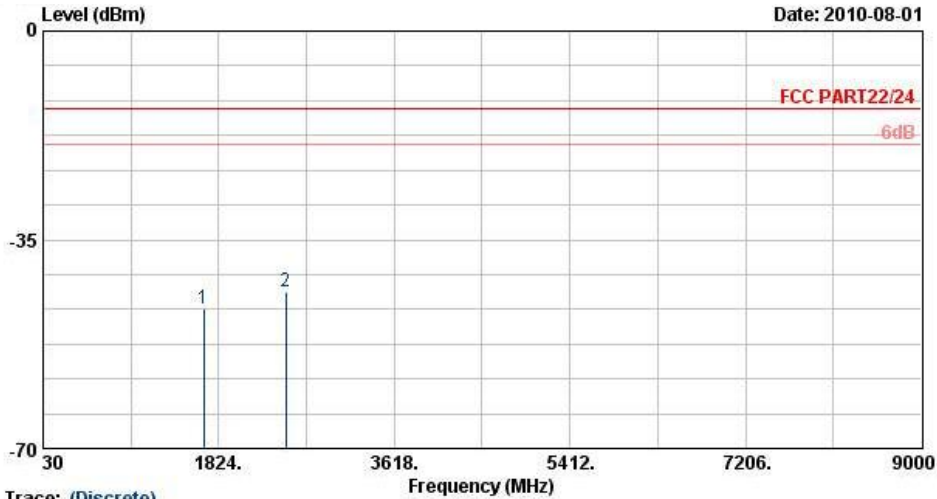

Trace: (Discrete)  
 Site : 08CH07-HY  
 Condition : FCC PART22/24 HF-ETRP(080306) VERTICAL  
 Project : FG 072126

| Frequency (MHz) | ERP (dBm) | Limit (dBm) | Over Limit (dB) | SPA Reading (dBm) | S.G. Power (dBm) | TX Cable loss (dB) | TX Antenna Gain (dBi) | Polarization (H/V) | Result |
|-----------------|-----------|-------------|-----------------|-------------------|------------------|--------------------|-----------------------|--------------------|--------|
| 1669            | -46.56    | -13         | -33.56          | -57.51            | -48.28           | 1.62               | 5.49                  | V                  | Pass   |
| 2509            | -43.68    | -13         | -30.68          | -57               | -45.65           | 2.1                | 6.22                  | V                  | Pass   |





|                        |                                                                                  |                            |            |
|------------------------|----------------------------------------------------------------------------------|----------------------------|------------|
| <b>Band :</b>          | CDMA2000 BC1                                                                     | <b>Temperature :</b>       | 28~29°C    |
| <b>Test Mode :</b>     | 1xRTT_RC3+SO55 for Sample 1                                                      | <b>Relative Humidity :</b> | 41~43%     |
| <b>Test Engineer :</b> | Kay Wu                                                                           | <b>Polarization :</b>      | Horizontal |
| <b>Remark :</b>        | Spurious emissions within 30-1000MHz were found more than 20dB below limit line. |                            |            |

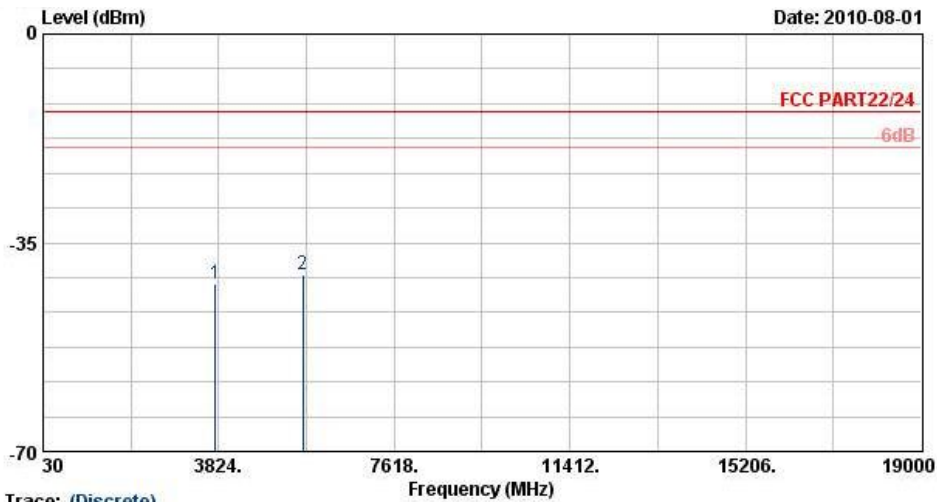

Trace: (Discrete)  
 Site : 08CH07-HY  
 Condition : FCC PART22/24 HF-EIRP(080306) HORIZONTAL  
 Project : FG 072126

| Frequency<br>( MHz ) | EIRP<br>( dBm ) | Limit<br>( dBm ) | Over<br>Limit<br>( dB ) | SPA<br>Reading<br>( dBm ) | S.G.<br>Power<br>( dBm ) | TX Cable<br>loss<br>( dB ) | TX Antenna<br>Gain<br>( dBi ) | Polarization<br>( H/V ) | Result |
|----------------------|-----------------|------------------|-------------------------|---------------------------|--------------------------|----------------------------|-------------------------------|-------------------------|--------|
| 3760                 | -41.87          | -13              | -28.87                  | -55.52                    | -48.17                   | 2.51                       | 8.81                          | H                       | Pass   |
| 5636                 | -40.30          | -13              | -27.30                  | -60.78                    | -48.01                   | 2.99                       | 10.70                         | H                       | Pass   |



|                        |                                                                                  |                            |          |
|------------------------|----------------------------------------------------------------------------------|----------------------------|----------|
| <b>Band :</b>          | CDMA2000 BC1                                                                     | <b>Temperature :</b>       | 28~29°C  |
| <b>Test Mode :</b>     | 1xRTT_RC3+SO55 for Sample 1                                                      | <b>Relative Humidity :</b> | 41~43%   |
| <b>Test Engineer :</b> | Kay Wu                                                                           | <b>Polarization :</b>      | Vertical |
| <b>Remark :</b>        | Spurious emissions within 30-1000MHz were found more than 20dB below limit line. |                            |          |

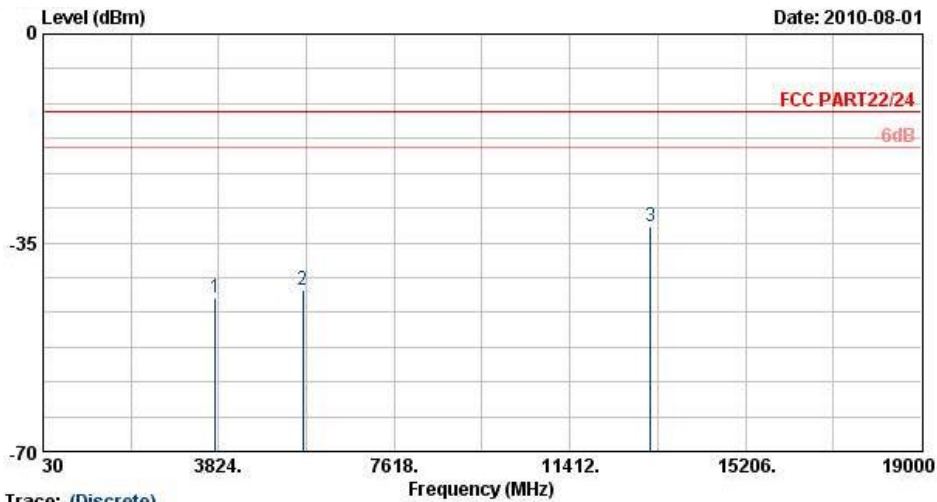

Trace: (Discrete)  
 Site : 08CH07-HY  
 Condition : FCC PART22/24 HF-EIRP(080306) VERTICAL  
 Project : FG 072126

| Frequency<br>( MHz ) | EIRP<br>( dBm ) | Limit<br>( dBm ) | Over<br>Limit<br>( dB ) | SPA<br>Reading<br>( dBm ) | S.G.<br>Power<br>( dBm ) | TX Cable<br>loss<br>( dB ) | TX Antenna<br>Gain<br>( dBi ) | Polarization<br>( H/V ) | Result |
|----------------------|-----------------|------------------|-------------------------|---------------------------|--------------------------|----------------------------|-------------------------------|-------------------------|--------|
| 3760                 | -44.23          | -13              | -31.23                  | -59.83                    | -50.53                   | 2.51                       | 8.81                          | V                       | Pass   |
| 5636                 | -42.86          | -13              | -29.86                  | -62.13                    | -50.57                   | 2.99                       | 10.70                         | V                       | Pass   |
| 13156                | -32.23          | -13              | -19.23                  | -65.2                     | -41.75                   | 4.27                       | 13.79                         | V                       | Pass   |



|                        |                                                                                  |                            |            |
|------------------------|----------------------------------------------------------------------------------|----------------------------|------------|
| <b>Band :</b>          | CDMA2000 BC1                                                                     | <b>Temperature :</b>       | 28~29°C    |
| <b>Test Mode :</b>     | 1xRTT_RC3+SO55 for Sample 2                                                      | <b>Relative Humidity :</b> | 41~43%     |
| <b>Test Engineer :</b> | Kay Wu                                                                           | <b>Polarization :</b>      | Horizontal |
| <b>Remark :</b>        | Spurious emissions within 30-1000MHz were found more than 20dB below limit line. |                            |            |

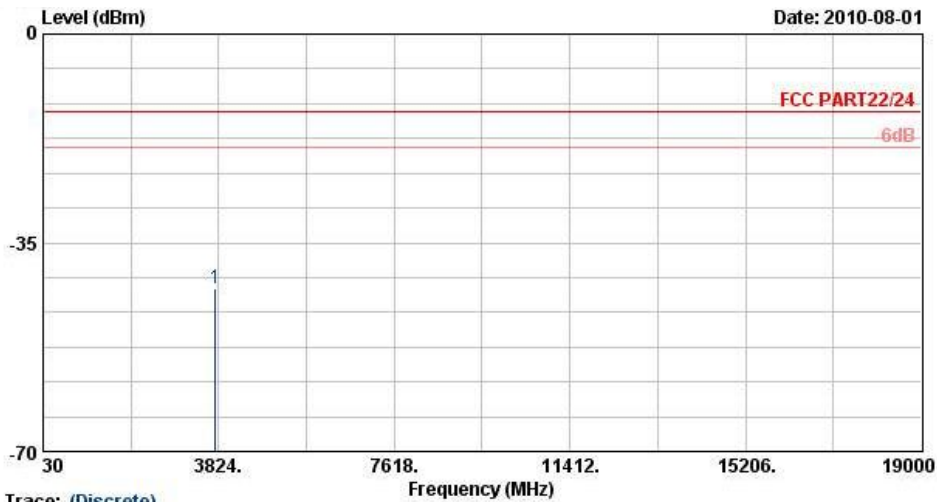

Trace: (Discrete)  
 Site : 08CH07-HY  
 Condition : FCC PART22/24 HF-EIRP(080306) HORIZONTAL  
 Project : FG 072126

| Frequency (MHz) | EIRP (dBm) | Limit (dBm) | Over Limit (dB) | SPA Reading (dBm) | S.G. Power (dBm) | TX Cable loss (dB) | TX Antenna Gain (dBi) | Polarization (H/V) | Result |
|-----------------|------------|-------------|-----------------|-------------------|------------------|--------------------|-----------------------|--------------------|--------|
| 3760            | -42.63     | -13         | -29.63          | -54.78            | -48.93           | 2.51               | 8.81                  | H                  | Pass   |



|                        |                                                                                  |                            |          |
|------------------------|----------------------------------------------------------------------------------|----------------------------|----------|
| <b>Band :</b>          | CDMA2000 BC1                                                                     | <b>Temperature :</b>       | 28~29°C  |
| <b>Test Mode :</b>     | 1xRTT_RC3+SO55 for Sample 2                                                      | <b>Relative Humidity :</b> | 41~43%   |
| <b>Test Engineer :</b> | Kay Wu                                                                           | <b>Polarization :</b>      | Vertical |
| <b>Remark :</b>        | Spurious emissions within 30-1000MHz were found more than 20dB below limit line. |                            |          |

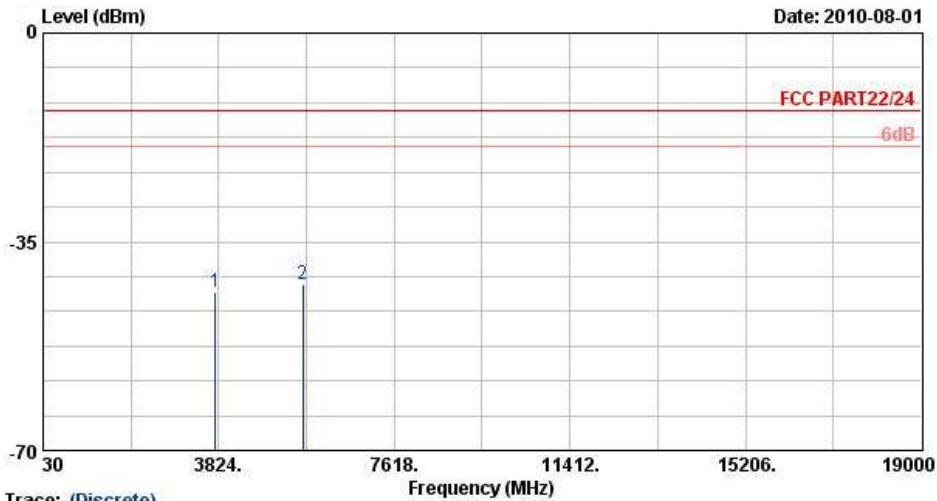

Trace: (Discrete)  
 Site : 03CH07-RY  
 Condition : FCC PART22/24 HF-ETRP(080306) VERTICAL  
 Project : FG 072126

| Frequency<br>( MHz ) | EIRP<br>( dBm ) | Limit<br>( dBm ) | Over<br>Limit<br>( dB ) | SPA<br>Reading<br>( dBm ) | S.G.<br>Power<br>( dBm ) | TX Cable<br>loss<br>( dB ) | TX Antenna<br>Gain<br>( dBi ) | Polarization<br>( H/V ) | Result |
|----------------------|-----------------|------------------|-------------------------|---------------------------|--------------------------|----------------------------|-------------------------------|-------------------------|--------|
| 3760                 | -43.58          | -13              | -30.58                  | -59.18                    | -49.88                   | 2.51                       | 8.81                          | V                       | Pass   |
| 5636                 | -42.11          | -13              | -29.11                  | -62.38                    | -49.82                   | 2.99                       | 10.70                         | V                       | Pass   |

## 3.7 Frequency Stability Measurement

### 3.7.1 Description of Frequency Stability Measurement

The frequency stability shall be measured by variation of ambient temperature and variation of primary supply voltage to ensure that the fundamental emission stays within the authorized frequency block. The frequency stability of the transmitter shall be maintained within  $\pm 0.00025\%$  ( $\pm 2.5\text{ppm}$ ) of the center frequency.

### 3.7.2 Measuring Instruments

See list of measuring instruments of this test report.

### 3.7.3 Test Procedures for Temperature Variation

1. The EUT was set up in the thermal chamber and connected with the base station.
2. With power OFF, the temperature was decreased to  $-30^{\circ}\text{C}$  and the EUT was stabilized for three hours. Power was applied and the maximum change in frequency was recorded within one minute.
3. With power OFF, the temperature was raised in  $10^{\circ}\text{C}$  step up to  $50^{\circ}\text{C}$ . The EUT was stabilized at each step for at least half an hour. Power was applied and the maximum frequency change was recorded within one minute.
4. If the EUT can not be turned on at  $-30^{\circ}\text{C}$ , the testing lowest temperature will be raised in  $10^{\circ}\text{C}$  step until the EUT can be turned on.

### 3.7.4 Test Procedures for Voltage Variation

1. The EUT was placed in a temperature chamber at  $25\pm 5^{\circ}\text{C}$  and connected with the base station.
2. The power supply voltage to the EUT was varied from BEP to 115% of the nominal value measured at the input to the EUT.
3. The variation in frequency was measured for the worst case.

### 3.7.5 Test Setup

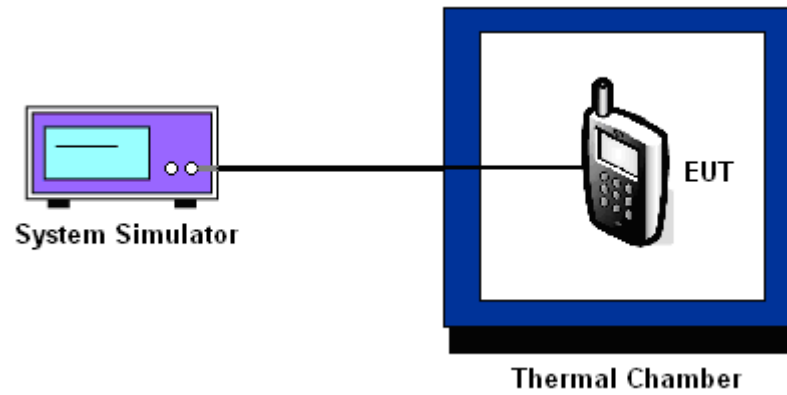



3.7.6 Test Result of Temperature Variation

|             |                |               |     |
|-------------|----------------|---------------|-----|
| Band :      | CDMA2000 BC0   | Channel :     | 384 |
| Test Mode : | 1xRTT_RC3+SO32 | Limit (ppm) : | 2.5 |

| Temperature (°C) | Freq. Dev. (Hz) | Deviation (ppm) | Result |
|------------------|-----------------|-----------------|--------|
| -30              | -               | -               | PASS   |
| -20              | -               | -               |        |
| -10              | -               | -               |        |
| 0                | -47.7           | -0.06           |        |
| 10               | -49.2           | -0.06           |        |
| 20               | -49.8           | -0.06           |        |
| 30               | -50.1           | -0.06           |        |
| 40               | -51.0           | -0.06           |        |
| 50               | -               | -               |        |

Note:

1. The EUT stops transmitting at temperatures -10°C ~ -30°C, and 50°C.
2. The manufacturer declared that the EUT could work properly between temperatures 0°C~40°C.

|             |                |               |     |
|-------------|----------------|---------------|-----|
| Band :      | CDMA2000 BC1   | Channel :     | 600 |
| Test Mode : | 1xRTT_RC3+SO55 | Limit (ppm) : | 2.5 |

| Temperature (°C) | Freq. Dev. (Hz) | Deviation (ppm) | Result |
|------------------|-----------------|-----------------|--------|
| -30              | -               | -               | PASS   |
| -20              | -               | -               |        |
| -10              | -               | -               |        |
| 0                | -49.0           | -0.03           |        |
| 10               | -50.9           | -0.03           |        |
| 20               | -46.0           | -0.02           |        |
| 30               | -50.4           | -0.03           |        |
| 40               | -48.9           | -0.03           |        |
| 50               | -               | -               |        |

Note:

1. The EUT stops transmitting at temperatures -10°C ~ -30°C, and 50°C.
2. The manufacturer declared that the EUT could work properly between temperatures 0°C~40°C.



3.7.7 Test Result of Voltage Variation

| Band & Channel        | Mode              | Voltage (Volt) | Freq. Dev. (Hz) | Deviation (ppm) | Limit (ppm) | Result |
|-----------------------|-------------------|----------------|-----------------|-----------------|-------------|--------|
| CDMA2000 BC0<br>CH384 | 1xRTT<br>RC3+SO32 | 3.8            | -50.1           | -0.06           | 2.5         | PASS   |
|                       |                   | BEP            | -46.6           | -0.05           |             |        |
|                       |                   | 4.2            | -49.4           | -0.06           |             |        |
| CDMA2000 BC1<br>CH600 | 1xRTT<br>RC3+SO55 | 3.8            | -47.5           | -0.03           | 2.5         | PASS   |
|                       |                   | BEP            | -48.1           | -0.03           |             |        |
|                       |                   | 4.2            | -46.7           | -0.02           |             |        |

Note :

- 1. Normal Voltage = 3.8V.
- 2. Battery End Point (BEP) = 3.6 V.





## 4 List of Measuring Equipment

| Instrument                | Manufacturer | Model No. | Serial No.      | Characteristics          | Calibration Date | Due Date      | Remark                |
|---------------------------|--------------|-----------|-----------------|--------------------------|------------------|---------------|-----------------------|
| System Simulator          | R&S          | CMU200    | 117995          | N/A                      | Mar. 19, 2009    | Mar. 18, 2011 | Conducted (TH02-HY)   |
| Spectrum Analyzer         | R&S          | FSP30     | 101329          | 9kHz~30GHz               | Apr. 26, 2010    | Apr. 25, 2011 | Conducted (TH02-HY)   |
| Thermal Chamber           | Ten Billion  | TTH-D35P  | TBN-930701      | N/A                      | Jul. 30,2010     | Jul. 29, 2011 | Conducted (TH02-HY)   |
| Bilog Antenna             | SCHAFFNER    | CBL6111C  | 2726            | 30MHz ~ 1GHz             | Oct. 31, 2009    | Oct. 30, 2010 | Radiation (03CH07-HY) |
| Spectrum Analyzer         | R&S          | FSP       | 101067          | 9KHz ~ 30GHz             | Dec. 04, 2009    | Dec. 03, 2010 | Radiation (03CH07-HY) |
| Double Ridge Horn Antenna | ESCO         | 3117      | 00075962        | 1GHz ~ 18GHz             | Aug. 20, 2009    | Aug. 19, 2010 | Radiation (03CH07-HY) |
| SHF-EHF Horn Antenna      | SCHWARZBECK  | BBHA 9170 | BBHA917025<br>1 | 15GHz- 40GHz             | Oct. 14, 2009    | Oct. 13, 2010 | Radiation (03CH07-HY) |
| Pre Amplifier             | Agilent      | 8449B     | 3008A02362      | 1GHz~ 26.5GHz            | Dec.09,2009      | Dec. 08, 2010 | Radiation (03CH07-HY) |
| Pre Amplifier             | COM-POWER    | PA-103A   | 161241          | 10-1000MHz.32dB.<br>GAIN | Mar. 27, 2010    | Mar. 26, 2011 | Radiation (03CH07-HY) |
| System Simulator          | R&S          | CMU200    | 117997          | N/A                      | May 14, 2009     | May 13, 2011  | Radiation (03CH07-HY) |

## 5 Uncertainty of Evaluation

### Uncertainty of Radiated Emission Measurement (30 MHz ~ 1000 MHz)

| Contribution                                                                             | Uncertainty of $X_i$ |                          | $u(X_i)$ |
|------------------------------------------------------------------------------------------|----------------------|--------------------------|----------|
|                                                                                          | dB                   | Probability Distribution |          |
| Receiver Reading                                                                         | 0.41                 | Normal (k=2)             | 0.21     |
| Antenna Factor Calibration                                                               | 0.83                 | Normal (k=2)             | 0.42     |
| Cable Loss Calibration                                                                   | 0.25                 | Normal (k=2)             | 0.13     |
| Pre-Amplifier Gain Calibration                                                           | 0.27                 | Normal (k=2)             | 0.14     |
| RCV/SPA Specification                                                                    | 2.50                 | Rectangular              | 0.72     |
| Antenna Factor Interpolation for Frequency                                               | 1.00                 | Rectangular              | 0.29     |
| Site Imperfection                                                                        | 1.43                 | Rectangular              | 0.83     |
| Mismatch                                                                                 | +0.39 / -0.41        | U-Shape                  | 0.28     |
| <b>Combined Standard Uncertainty <math>U_c(y)</math></b>                                 | <b>1.27</b>          |                          |          |
| <b>Measuring Uncertainty for a Level of Confidence of 95% (<math>U = 2U_c(y)</math>)</b> | <b>2.54</b>          |                          |          |

### Uncertainty of Radiated Emission Measurement (1 GHz ~ 40 GHz)

| Contribution                                                                                                                         | Uncertainty of $X_i$ |                          | $u(X_i)$ | $C_i$ | $C_i * u(X_i)$ |
|--------------------------------------------------------------------------------------------------------------------------------------|----------------------|--------------------------|----------|-------|----------------|
|                                                                                                                                      | dB                   | Probability Distribution |          |       |                |
| Receiver Reading                                                                                                                     | $\pm 0.10$           | Normal (k=2)             | 0.10     | 1     | 0.10           |
| Antenna Factor Calibration                                                                                                           | $\pm 1.70$           | Normal (k=2)             | 0.85     | 1     | 0.85           |
| Cable Loss Calibration                                                                                                               | $\pm 0.50$           | Normal (k=2)             | 0.25     | 1     | 0.25           |
| Receiver Correction                                                                                                                  | $\pm 2.00$           | Rectangular              | 1.15     | 1     | 1.15           |
| Antenna Factor Directional                                                                                                           | $\pm 1.50$           | Rectangular              | 0.87     | 1     | 0.87           |
| Site Imperfection                                                                                                                    | $\pm 2.80$           | Triangular               | 1.14     | 1     | 1.14           |
| Mismatch<br>Receiver VSWR $\Gamma_1 = 0.197$<br>Antenna VSWR $\Gamma_2 = 0.194$<br>Uncertainty = $20\text{Log}(1-\Gamma_1*\Gamma_2)$ | +0.34 / -0.35        | U-Shape                  | 0.244    | 1     | 0.244          |
| <b>Combined Standard Uncertainty <math>U_c(y)</math></b>                                                                             | <b>2.36</b>          |                          |          |       |                |
| <b>Measuring Uncertainty for a Level of Confidence of 95% (<math>U = 2U_c(y)</math>)</b>                                             | <b>4.72</b>          |                          |          |       |                |