

HAC_E_Dipole_835_100619

DUT: Dipole 835 MHz

Communication System: GSM850; Frequency: 835 MHz; Duty Cycle: 1:1

Medium: Air Medium parameters used: $\sigma = 0$ mho/m, $\epsilon_r = 1$; $\rho = 1000$ kg/m³

Ambient Temperature : 22.3

DASY5 Configuration:

- Probe: ER3DV6 - SN2358; ConvF(1, 1, 1); Calibrated: 2010/1/22
- Sensor-Surface: (Fix Surface)
- Electronics: DAE4 Sn778; Calibrated: 2009/9/18
- Phantom: HAC Test Arch with AMCC; Type: SD HAC P01 BA;
- Measurement SW: DASY5, V5.0 Build 125; SEMCAD X Version 13.4 Build 125

E Scan - measurement distance from the probe sensor center to CD835 Dipole = 10mm/Hearing Aid Compatibility Test (41x361x1): Measurement grid: dx=5mm, dy=5mm

Probe Modulation Factor = 1

Reference Value = 130.1 V/m; Power Drift = -0.043 dB

Average Value of Total = $(171.8 + 174.1) / 2 = 172.95$ V/m

Peak E-field in V/m

Grid 1 164.9 M4	Grid 2 171.8 M4	Grid 3 166.2 M4
Grid 4 90.4 M4	Grid 5 93.8 M4	Grid 6 91.3 M4
Grid 7 170.8 M4	Grid 8 174.1 M4	Grid 9 168.4 M4

Cursor:

Total = 174.1 V/m

E Category: M4

Location: 0.5, 73.5, 4.7 mm

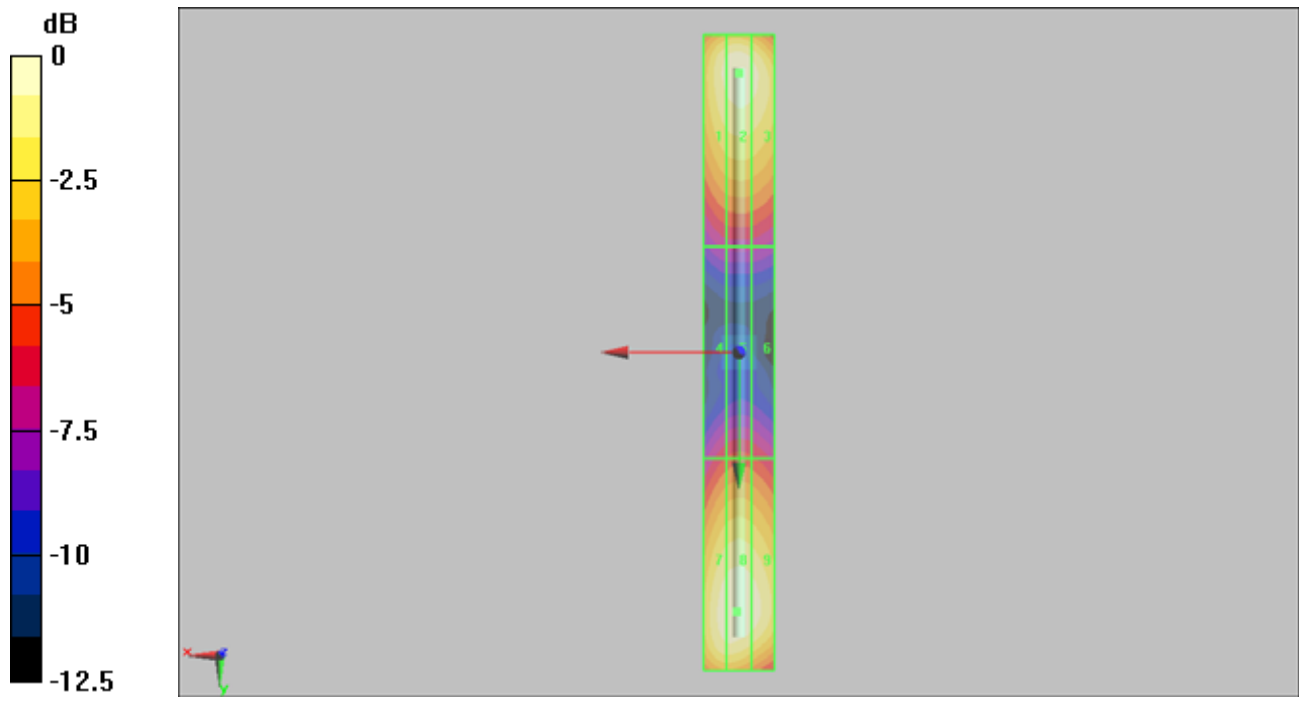

0 dB = 174.1V/m

HAC_E_Dipole_835_100707

DUT: Dipole 835 MHz

Communication System: GSM850; Frequency: 835 MHz; Duty Cycle: 1:1

Medium: Air Medium parameters used: $\sigma = 0$ mho/m, $\epsilon_r = 1$; $\rho = 1000$ kg/m³

Ambient Temperature : 22.4

DASY5 Configuration:

- Probe: ER3DV6 - SN2358; ConvF(1, 1, 1); Calibrated: 2010/1/22
- Sensor-Surface: (Fix Surface)
- Electronics: DAE4 Sn778; Calibrated: 2009/9/18
- Phantom: HAC Test Arch with AMCC; Type: SD HAC P01 BA;
- Measurement SW: DASY5, V5.0 Build 125; SEMCAD X Version 13.4 Build 125

E Scan - measurement distance from the probe sensor center to CD835 Dipole = 10mm/Hearing Aid Compatibility Test (41x361x1): Measurement grid: dx=5mm, dy=5mm

Probe Modulation Factor = 1

Reference Value = 142.9 V/m; Power Drift = -0.015 dB

Average Value of Total = $(166.6 + 198.4) / 2 = 182.5$ V/m

Peak E-field in V/m

Grid 1 160.8 M4	Grid 2 166.6 M4	Grid 3 161.9 M4
Grid 4 97.8 M4	Grid 5 101.5 M4	Grid 6 98.8 M4
Grid 7 194.4 M4	Grid 8 198.4 M4	Grid 9 191.9 M4

Cursor:

Total = 198.4 V/m

E Category: M4

Location: 0, 74, 4.7 mm

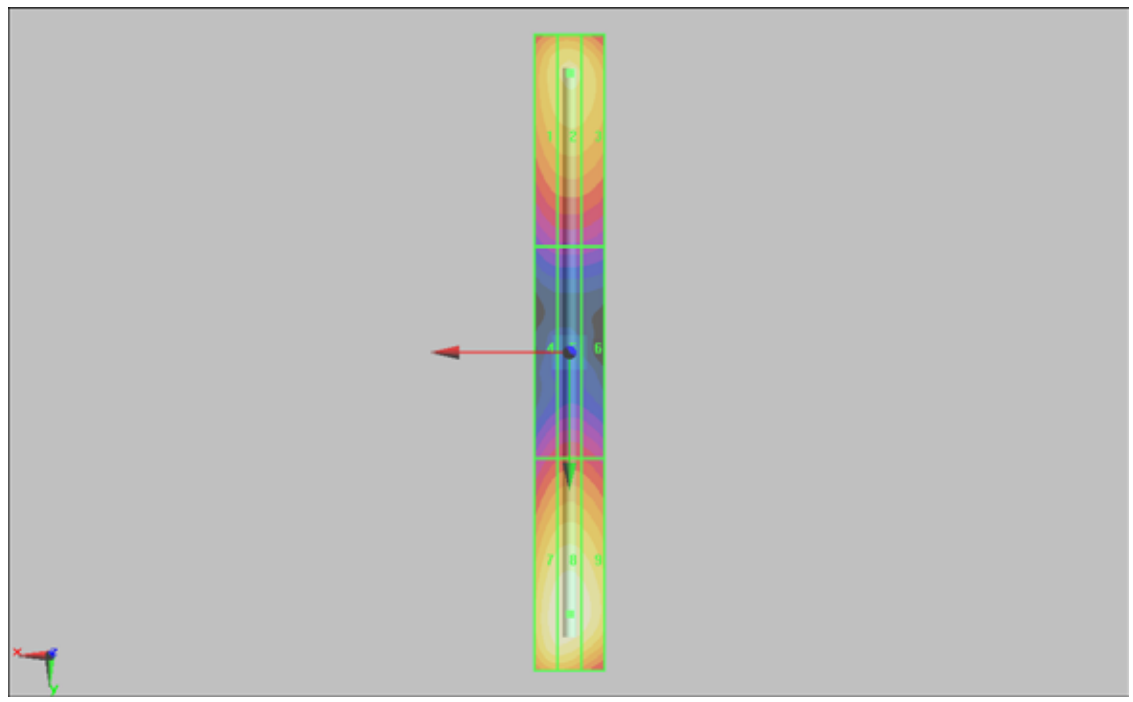
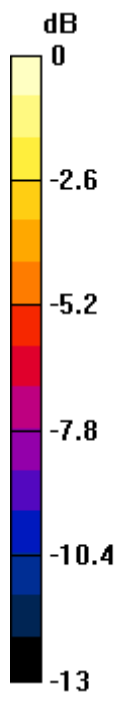

0 dB = 198.4V/m

HAC_E_Dipole_1880_100619

DUT: HAC Dipole 1880 MHz

Communication System: GSM850; Frequency: 1880 MHz; Duty Cycle: 1:1
 Medium: Air Medium parameters used: $\sigma = 0$ mho/m, $\epsilon_r = 1$; $\rho = 1000$ kg/m³
 Ambient Temperature : 22.6

DASY5 Configuration:

- Probe: ER3DV6 - SN2358; ConvF(1, 1, 1); Calibrated: 2010/1/22
- Sensor-Surface: (Fix Surface)
- Electronics: DAE4 Sn778; Calibrated: 2009/9/18
- Phantom: HAC Test Arch with AMCC; Type: SD HAC P01 BA;
- Measurement SW: DASY5, V5.0 Build 125; SEMCAD X Version 13.4 Build 125

E Scan - measurement distance from the probe sensor center to CD1880 Dipole = 10mm/Hearing Aid Compatibility Test (41x181x1): Measurement grid: dx=5mm, dy=5mm

Probe Modulation Factor = 1
 Device Reference Point: 0, 0, -6.3 mm
 Average Value of Total = $(136.1 + 138.0) / 2 = 137.05$ V/m

Peak E-field in V/m

Grid 1 133.3 M2	Grid 2 136.1 M2	Grid 3 130.0 M2
Grid 4 91.6 M3	Grid 5 95.5 M3	Grid 6 94.2 M3
Grid 7 134.3 M2	Grid 8 138.0 M2	Grid 9 134.6 M2

Cursor:

Total = 138.0 V/m
 E Category: M2
 Location: 0, 32, 4.7 mm

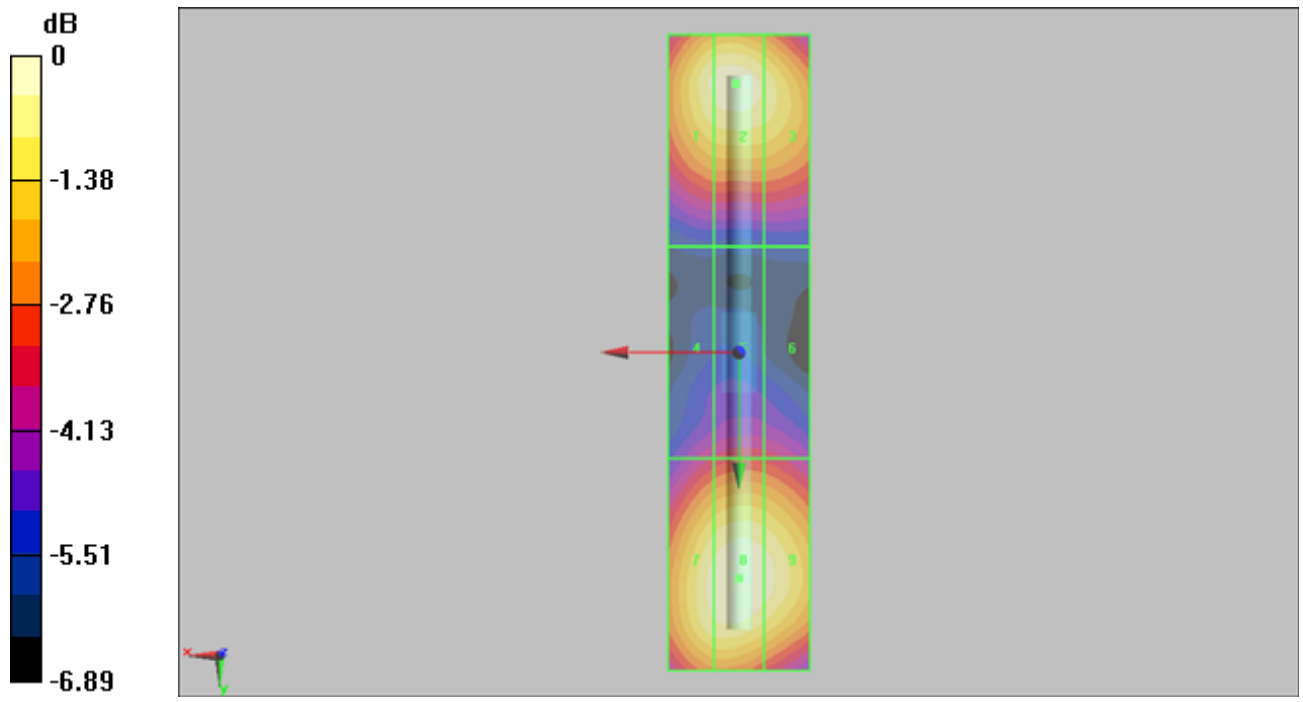

0 dB = 138.0V/m

HAC_E_Dipole_1880_100707**DUT: HAC Dipole 1880 MHz**

Communication System: GSM850; Frequency: 1880 MHz; Duty Cycle: 1:1
 Medium: Air Medium parameters used: $\sigma = 0$ mho/m, $\epsilon_r = 1$; $\rho = 1000$ kg/m³
 Ambient Temperature : 22.4

DASY5 Configuration:

- Probe: ER3DV6 - SN2358; ConvF(1, 1, 1); Calibrated: 2010/1/22
- Sensor-Surface: (Fix Surface)
- Electronics: DAE4 Sn778; Calibrated: 2009/9/18
- Phantom: HAC Test Arch with AMCC; Type: SD HAC P01 BA;
- Measurement SW: DASY5, V5.0 Build 125; SEMCAD X Version 13.4 Build 125

E Scan - measurement distance from the probe sensor center to CD1880 Dipole = 10mm/Hearing Aid Compatibility Test (41x181x1): Measurement grid: dx=5mm, dy=5mm

Probe Modulation Factor = 1

Reference Value = 142.4 V/m; Power Drift = -0.021 dB

Average Value of Total = (138.4 + 140.4) / 2 = 139.4 V/m

Peak E-field in V/m

Grid 1 135.7 M2	Grid 2 138.4 M2	Grid 3 132.3 M2
Grid 4 93.2 M3	Grid 5 97.1 M3	Grid 6 96 M3
Grid 7 136.5 M2	Grid 8 140.4 M2	Grid 9 137.0 M2

Cursor:

Total = 140.4 V/m

E Category: M2

Location: -0.5, 31.5, 4.7 mm

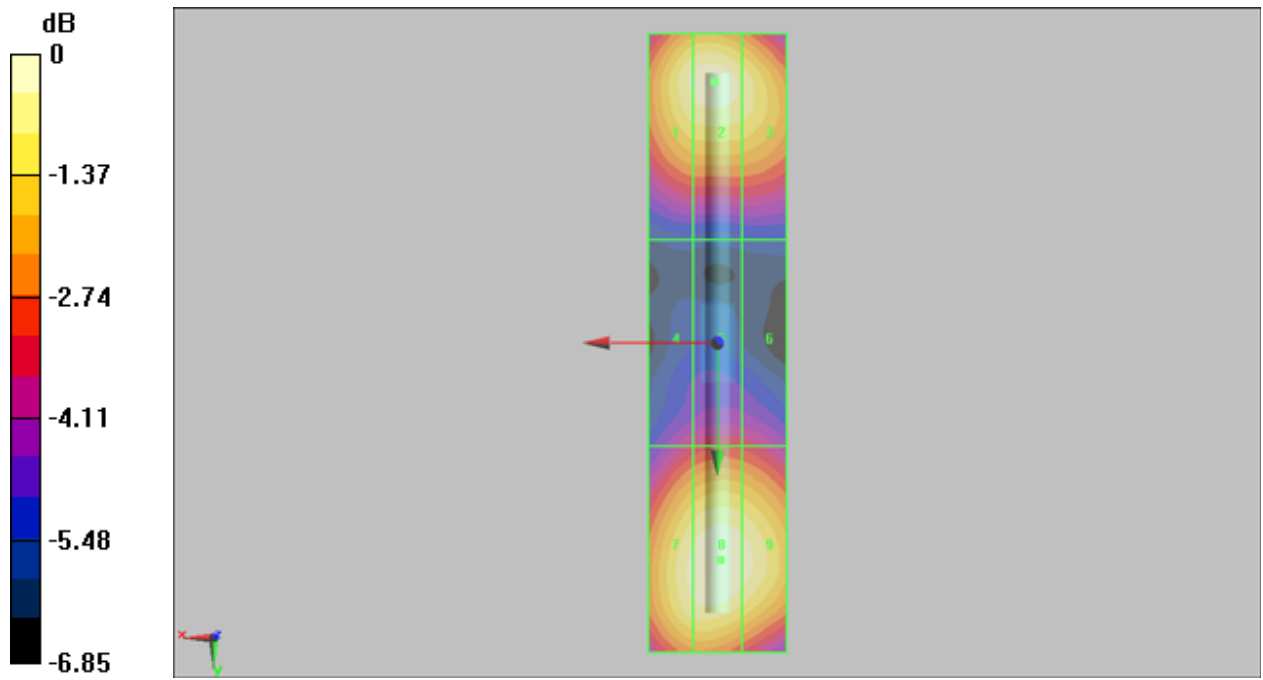

0 dB = 140.4V/m

HAC_H_Dipole_835_100619**DUT: HAC-Dipole 835 MHz**

Communication System: CW; Frequency: 835 MHz; Duty Cycle: 1:1

Medium: Air Medium parameters used: $\sigma = 0$ mho/m, $\epsilon_r = 1$; $\rho = 1$ kg/m³

Ambient Temperature : 22.3

DASY5 Configuration:

- Probe: H3DV6 - SN6184; ; Calibrated: 2010/1/22

- Sensor-Surface: (Fix Surface)

- Electronics: DAE4 Sn778; Calibrated: 2009/9/18

- Phantom: HAC Test Arch with AMCC; Type: SD HAC P01 BA;

- Measurement SW: DASY5, V5.0 Build 125; SEMCAD X Version 13.4 Build 125

H Scan - measurement distance from the probe sensor center to CD835 Dipole = 10mm/Hearing Aid Compatibility Test (41x361x1): Measurement grid: dx=5mm, dy=5mm

Probe Modulation Factor = 1

Reference Value = 0.532 A/m; Power Drift = -0.020 dB

Maximun Value of Total = 0.480 A/m

Peak H-field in A/m

Grid 1 0.406 M4	Grid 2 0.423 M4	Grid 3 0.403 M4
Grid 4 0.460 M4	Grid 5 0.480 M4	Grid 6 0.458 M4
Grid 7 0.412 M4	Grid 8 0.429 M4	Grid 9 0.408 M4

Cursor:

Total = 0.480 A/m

H Category: M4

Location: 0, 4, 5.2 mm

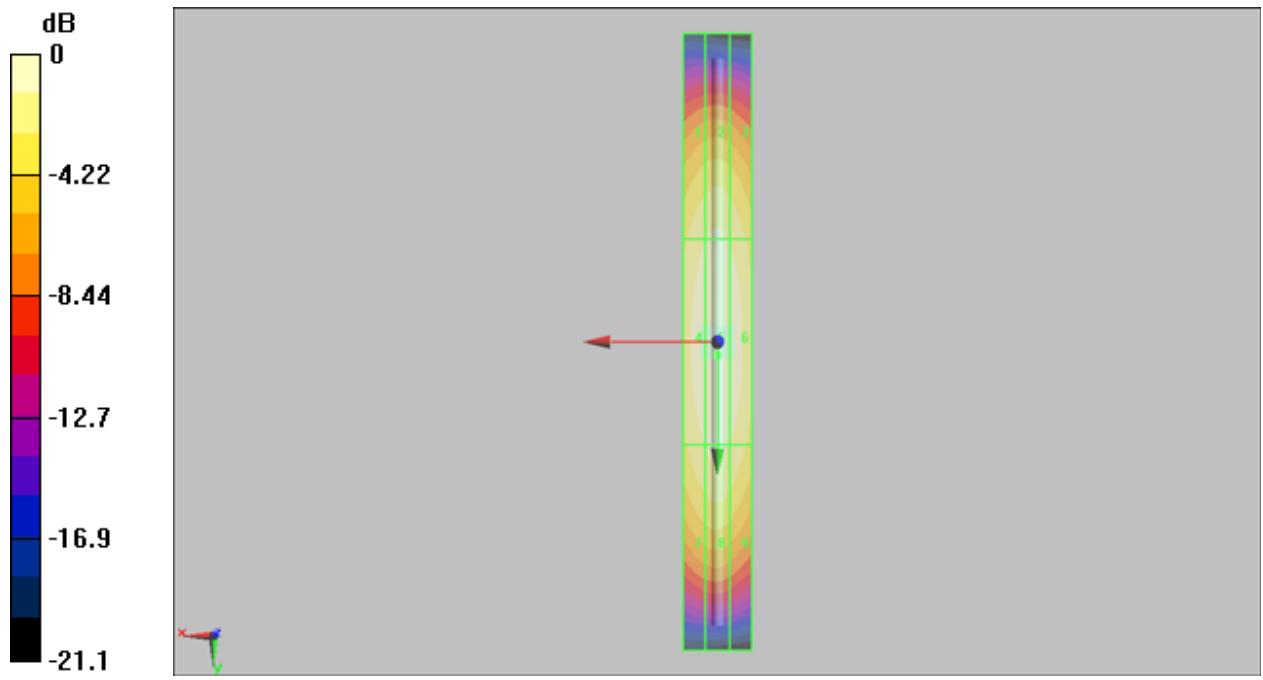

0 dB = 0.480A/m

HAC_H_Dipole_835_100707

DUT: HAC-Dipole 835 MHz

Communication System: CW; Frequency: 835 MHz; Duty Cycle: 1:1

Medium: Air Medium parameters used: $\sigma = 0$ mho/m, $\epsilon_r = 1$; $\rho = 1$ kg/m³

Ambient Temperature : 22.3

DASY5 Configuration:

- Probe: H3DV6 - SN6184; ; Calibrated: 2010/1/22

- Sensor-Surface: (Fix Surface)

- Electronics: DAE4 Sn778; Calibrated: 2009/9/18

- Phantom: HAC Test Arch with AMCC; Type: SD HAC P01 BA;

- Measurement SW: DASY5, V5.0 Build 125; SEMCAD X Version 13.4 Build 125

H Scan - measurement distance from the probe sensor center to CD835 Dipole = 10mm/Hearing Aid Compatibility Test (41x361x1): Measurement grid: dx=5mm, dy=5mm

Probe Modulation Factor = 1

Reference Value = 0.492 A/m; Power Drift = -0.00564 dB

Maximum Value of Total = 0.443 A/m

Peak H-field in A/m

Grid 1 0.377 M4	Grid 2 0.388 M4	Grid 3 0.362 M4
Grid 4 0.429 M4	Grid 5 0.443 M4	Grid 6 0.415 M4
Grid 7 0.383 M4	Grid 8 0.398 M4	Grid 9 0.371 M4

Cursor:

Total = 0.443 A/m

H Category: M4

Location: 0.5, 2.5, 5.2 mm

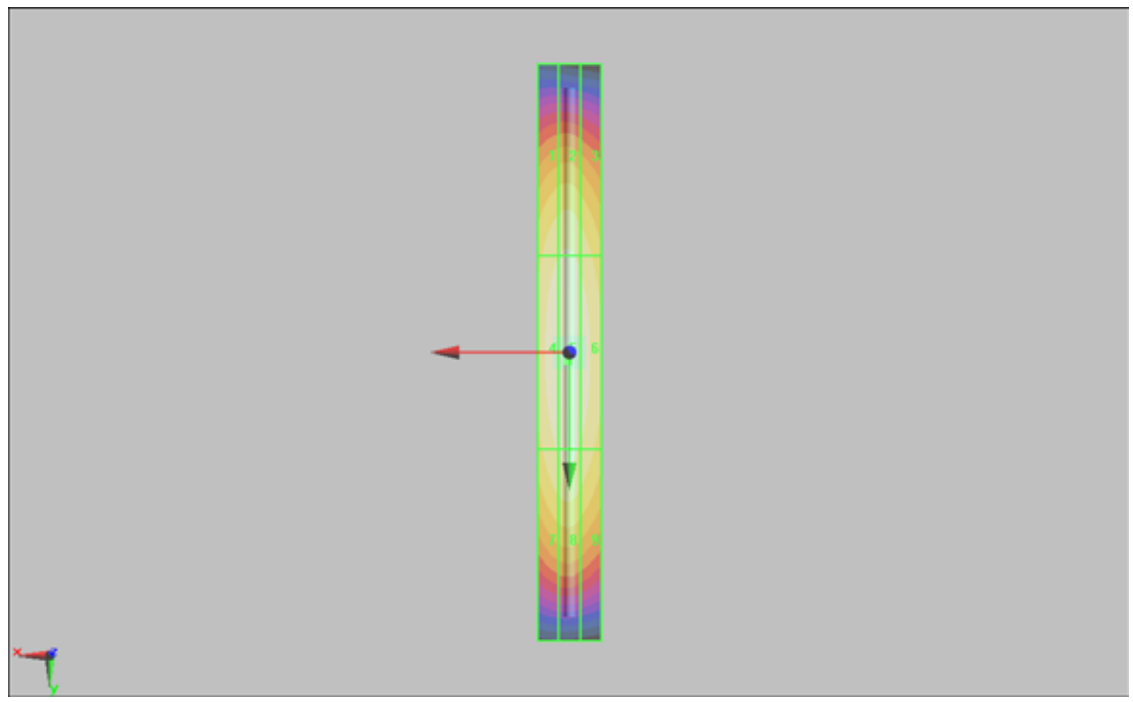
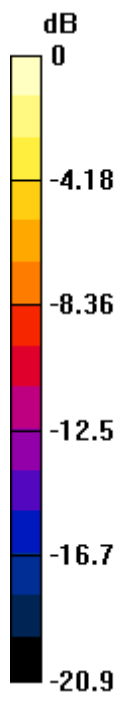

0 dB = 0.443A/m

HAC_H_Dipole_1880_100619**DUT: HAC Dipole 1880 MHz**

Communication System: CW; Frequency: 1880 MHz; Duty Cycle: 1:1

Medium: Air Medium parameters used: $\sigma = 0$ mho/m, $\epsilon_r = 1$; $\rho = 1$ kg/m³

Ambient Temperature : 22.5

DASY5 Configuration:

- Probe: H3DV6 - SN6184; ; Calibrated: 2010/1/22

- Sensor-Surface: (Fix Surface)

- Electronics: DAE4 Sn778; Calibrated: 2009/9/18

- Phantom: HAC Test Arch with AMCC; Type: SD HAC P01 BA;

- Measurement SW: DASY5, V5.0 Build 125; SEMCAD X Version 13.4 Build 125

H Scan - measurement distance from the probe sensor center to CD1880 Dipole = 10mm/Hearing Aid Compatibility Test (41x181x1): Measurement grid: dx=5mm, dy=5mm

Probe Modulation Factor = 1

Reference Value = 0.536 A/m; Power Drift = -0.00847 dB

Maximun Value of Total = 0.487 A/m

Peak H-field in A/m

Grid 1 0.426 M2	Grid 2 0.436 M2	Grid 3 0.409 M2
Grid 4 0.473 M2	Grid 5 0.487 M2	Grid 6 0.458 M2
Grid 7 0.434 M2	Grid 8 0.450 M2	Grid 9 0.422 M2

Cursor:

Total = 0.487 A/m

H Category: M2

Location: 0.5, 1, 5.2 mm

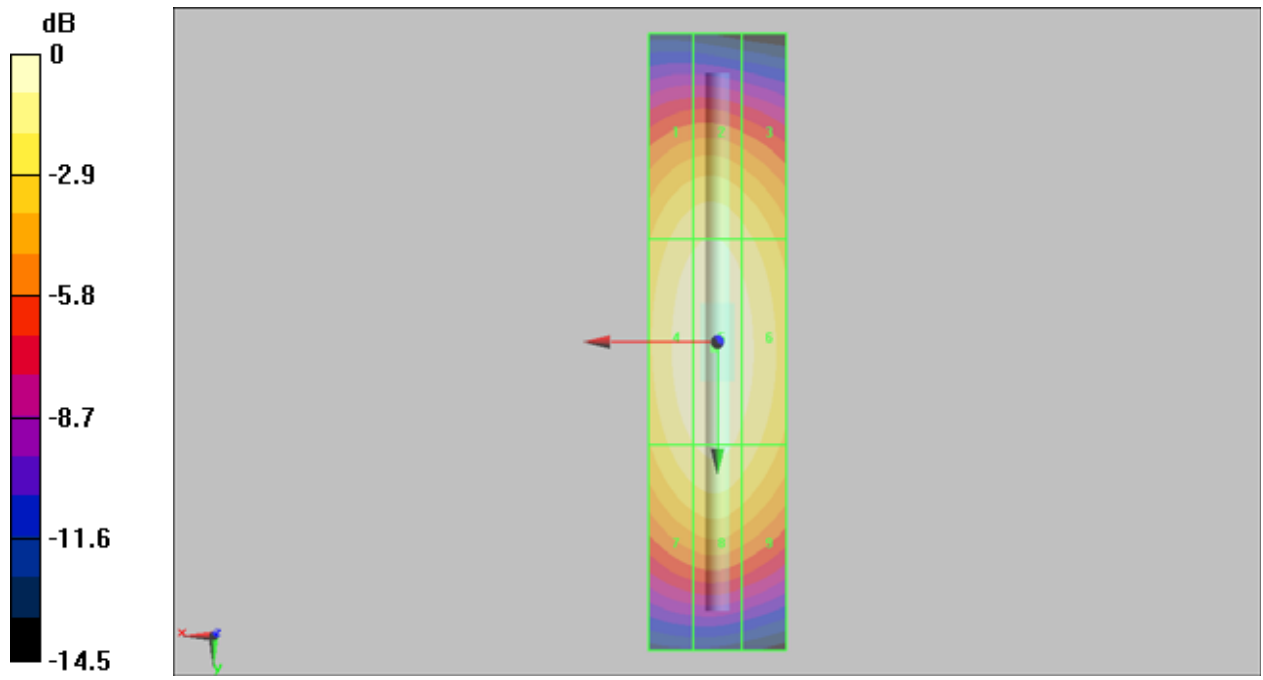

0 dB = 0.487A/m

HAC_H_Dipole_1880_100707**DUT: HAC Dipole 1880 MHz**

Communication System: CW; Frequency: 1880 MHz; Duty Cycle: 1:1

Medium: Air Medium parameters used: $\sigma = 0$ mho/m, $\epsilon_r = 1$; $\rho = 1$ kg/m³

Ambient Temperature : 22.3

DASY5 Configuration:

- Probe: H3DV6 - SN6184; ; Calibrated: 2010/1/22

- Sensor-Surface: (Fix Surface)

- Electronics: DAE4 Sn778; Calibrated: 2009/9/18

- Phantom: HAC Test Arch with AMCC; Type: SD HAC P01 BA;

- Measurement SW: DASY5, V5.0 Build 125; SEMCAD X Version 13.4 Build 125

H Scan - measurement distance from the probe sensor center to CD1880 Dipole = 10mm/Hearing Aid Compatibility Test (41x181x1): Measurement grid: dx=5mm, dy=5mm

Probe Modulation Factor = 1

Device Reference Point: 0, 0, -6.3 mm

Maximum Value of Total = 0.470 A/m

Peak H-field in A/m

Grid 1 0.412 M2	Grid 2 0.422 M2	Grid 3 0.395 M2
Grid 4 0.457 M2	Grid 5 0.470 M2	Grid 6 0.442 M2
Grid 7 0.419 M2	Grid 8 0.434 M2	Grid 9 0.407 M2

Cursor:

Total = 0.470 A/m

H Category: M2

Location: 0.5, 1, 5.2 mm

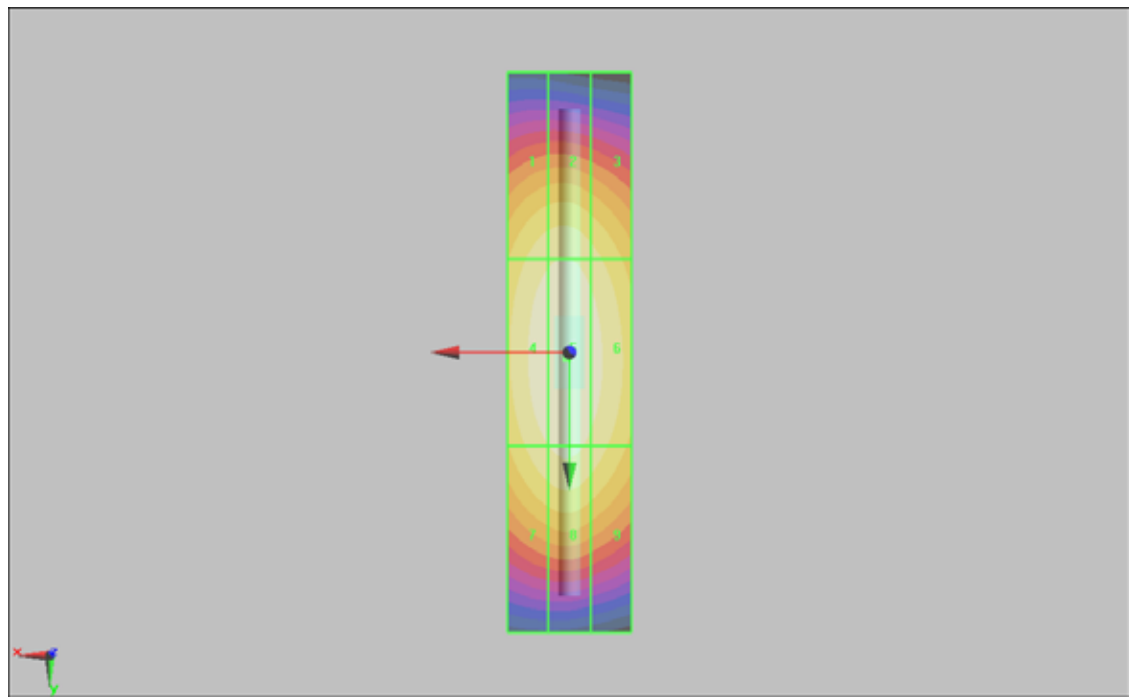
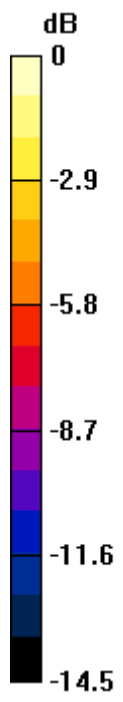

0 dB = 0.470A/m