



A D T

FCC TEST REPORT (PART 24)

REPORT NO.: RF981217L06-1

MODEL NO.: PB31200

RECEIVED: Dec. 17, 2009

TESTED: Dec. 18, 2009 ~ Jan. 27, 2010

ISSUED: Feb. 01, 2010

APPLICANT: HTC Corporation

ADDRESS: No. 23, Xinghua Rd., Taoyuan City, Taiwan, R.O.C.

ISSUED BY: Bureau Veritas Consumer Products Services (H.K.)
Ltd., Taoyuan Branch

LAB ADDRESS: No. 47, 14th Ling, Chia Pau Tsuen, Lin Kou Hsiang,
Taipei Hsien 244, Taiwan, R.O.C.

TEST LOCATION: No. 19, Hwa Ya 2nd Rd, Wen Hwa Tsuen, Kwei
Shan Hsiang, Taoyuan Hsien 333, Taiwan, R.O.C.

This test report consists of 52 pages in total. It may be duplicated completely for legal use with the approval of the applicant. It should not be reproduced except in full, without the written approval of our laboratory. The client should not use it to claim product endorsement by TAF or any government agencies. The test results in the report only apply to the tested sample.





A D T

TABLE OF CONTENTS

1	CERTIFICATION	4
2	SUMMARY OF TEST RESULTS	5
2.1	MEASUREMENT UNCERTAINTY	5
3	GENERAL INFORMATION.....	6
3.1	GENERAL DESCRIPTION OF EUT.....	6
3.2	DESCRIPTION OF TEST MODES.....	6
3.2.1	CONFIGURATION OF SYSTEM UNDER TEST.....	8
3.2.2	TEST MODE APPLICABILITY AND TESTED CHANNEL DETAIL.....	9
3.3	GENERAL DESCRIPTION OF APPLIED STANDARDS	11
3.4	DESCRIPTION OF SUPPORT UNITS	11
4	TEST TYPES AND RESULTS	12
4.1	OUTPUT POWER MEASUREMENT	12
4.1.1	LIMITS OF OUTPUT POWER MEASUREMENT.....	12
4.1.2	TEST INSTRUMENTS	13
4.1.3	TEST PROCEDURES	14
4.1.4	TEST SETUP	15
4.1.5	EUT OPERATING CONDITIONS.....	15
4.1.6	TEST RESULTS	16
4.2	FREQUENCY STABILITY MEASUREMENT	18
4.2.1	LIMITS OF FREQUENCY STABILITY MEASUREMENT.....	18
4.2.2	TEST INSTRUMENTS	18
4.2.3	TEST PROCEDURE	19
4.2.4	TEST SETUP	19
4.2.5	TEST RESULTS	20
4.3	OCCUPIED BANDWIDTH MEASUREMENT.....	21
4.3.1	LIMITS OF OCCUPIED BANDWIDTH MEASUREMENT	21
4.3.2	TEST INSTRUMENTS	21
4.3.3	TEST SETUP	21
4.3.4	TEST PROCEDURES	22
4.3.5	TEST RESULTS	23
4.4	BAND EDGE MEASUREMENT	29
4.4.1	LIMITS OF BAND EDGE MEASUREMENT.....	29
4.4.2	TEST INSTRUMENTS	29
4.4.3	TEST SETUP	29
4.4.4	TEST PROCEDURES	30
4.4.5	EUT OPERATING CONDITION	30
4.4.6	TEST RESULTS	31
4.5	CONDUCTED SPURIOUS EMISSIONS.....	34
4.5.1	LIMITS OF CONDUCTED SPURIOUS EMISSIONS MEASUREMENT	34
4.5.2	TEST INSTRUMENTS	34
4.5.3	TEST PROCEDURE	35
4.5.4	TEST SETUP	35



A D T

4.5.5	EUT OPERATING CONDITIONS	35
4.5.6	TEST RESULTS	36
4.6	RADIATED EMISSION MEASUREMENT (BELOW 1GHz).....	41
4.6.1	LIMITS OF RADIATED EMISSION MEASUREMENT	41
4.6.2	TEST INSTRUMENTS	41
4.6.3	TEST PROCEDURES	42
4.6.4	DEVIATION FROM TEST STANDARD	42
4.6.5	TEST SETUP	43
4.6.6	EUT OPERATING CONDITIONS	43
4.6.7	TEST RESULTS	44
4.7	RADIATED EMISSION MEASUREMENT (ABOVE 1GHz)	45
4.7.1	LIMITS OF RADIATED EMISSION MEASUREMENT	45
4.7.2	TEST INSTRUMENTS	45
4.7.3	TEST PROCEDURES	46
4.7.4	DEVIATION FROM TEST STANDARD	46
4.7.5	TEST SETUP	47
4.7.6	EUT OPERATING CONDITIONS	47
4.7.7	TEST RESULTS	48
5	INFORMATION ON THE TESTING LABORATORIES	51
6	APPENDIX A – MODIFICATIONS RECORDERS FOR ENGINEERING CHANGES TO THE EUT BY THE LAB.....	52



A D T

1 CERTIFICATION

PRODUCT : Smartphone

MODEL : PB31200

APPLICANT : HTC Corporation

TESTED : Dec. 18, 2009 ~ Jan. 27, 2010

TEST SAMPLE : ENGINEERING SAMPLE

TEST STANDARDS : FCC Part 24, Subpart E

ANSI C63.4-2003

The above equipment (model: PB31200) has been tested by **Bureau Veritas Consumer Products Services (H.K.) Ltd., Taoyuan Branch**, and found compliance with the requirement of the above standards. The test record, data evaluation & Equipment Under Test (EUT) configurations represented herein are true and accurate accounts of the measurements of the sample's EMC characteristics under the conditions specified in this report.

PREPARED BY : Rennie Wang , **DATE**: Feb. 01, 2010
Rennie Wang / Supervisor

TECHNICAL ACCEPTANCE : Long Chen , **DATE**: Feb. 01, 2010
Responsible for RF Long Chen / Senior Engineer

APPROVED BY : Gary Chang , **DATE**: Feb. 01, 2010
Gary Chang / Assistant Manager

2 SUMMARY OF TEST RESULTS

The EUT has been tested according to the following specifications:

APPLIED STANDARD: FCC Part 24 & Part 2 / IC RSS-133			
STANDARD SECTION	TEST TYPE AND LIMIT	RESULT	REMARK
2.1046 24.232	Maximum Peak Output Power Limit: max. 2 watts e.i.r.p peak power	PASS	Meet the requirement of limit. Minimum passing margin is 26.10dBm at 1851.25MHz.
2.1055 24.235	Frequency Stability AFC Freq. Error vs. Voltage AFC Freq. Error vs. Temperature Limit: max. ± 2.5 ppm	PASS	Meet the requirement of limit.
2.1049 24.238(b)	Occupied Bandwidth	PASS	Meet the requirement of limit.
24.238(b)	Band Edge Measurements	PASS	Meet the requirement of limit.
2.1051 24.238	Conducted Spurious Emissions	PASS	Meet the requirement of limit.
2.1053 24.238	Radiated Spurious Emissions	PASS	Meet the requirement of limit. Minimum passing margin is -11.3dB at 3817.5MHz.

2.1 MEASUREMENT UNCERTAINTY

Where relevant, the following measurement uncertainty levels have been estimated for tests performed on the EUT as specified in CISPR 16-4-2:

MEASUREMENT	FREQUENCY	UNCERTAINTY
Conducted emissions	150kHz~30MHz	2.44 dB
Radiated emissions	30MHz ~ 200MHz	3.34 dB
	200MHz ~1000MHz	3.35 dB
	1GHz ~ 18GHz	2.26 dB
	18GHz ~ 40GHz	1.94 dB

This uncertainty represents an expanded uncertainty expressed at approximately the 95% confidence level using a coverage factor of $k=2$.



A D T

3 GENERAL INFORMATION

3.1 GENERAL DESCRIPTION OF EUT

PRODUCT	Smartphone
MODEL NO.	PB31200
FCC ID	NM8PB31200
POWER SUPPLY	3.7Vdc from rechargeable lithium battery 5.0Vdc from power adapter 5.0Vdc from host equipment
MODULATION TYPE	OQPSK, HPSK
OPERATING FREQUENCY	1851.25MHz ~ 1908.75MHz
NUMBER OF CHANNEL	1151
MAX. EIRP POWER	26.10dBm (407.4mW)
ANTENNA TYPE	PIFA antenna
ANTENNA GAIN	1.0dBi
DATA CABLE	Refer to NOTE
I/O PORTS	Refer to user's manual
ACCESSORY DEVICES	Refer to NOTE
EUT EXTREME VOL. RANGE	3.6Vdc to 4.2Vdc

NOTE:

1. The applicant defined the normal working voltage of the battery is from 3.6Vdc to 4.2Vdc.
2. The EUT is a Smartphone. The functions of EUT listed as below:

	TEST STANDARD	REFERENCE REPORT
CDMA 850	FCC Part 22	RF981217L06
CDMA 1900	FCC Part 24	RF981217L06-1
WLAN 802.11b/g	FCC Part 15	RF981217L06-2
BLUETOOTH	(Section 15.247)	RF981217L06-3



A D T

3. The communicated functions of EUT listed as below:

		850MHz	1900MHz	With WLAN 802.11b/g + BT 2.0 with EDR + GPS
3G	CDMA	√	√	
	1*EV-DO	√	√	
	1*EV-DO Rev. A	√	√	
	1*RTT	√	√	
	IS-95A/B	√	√	

4. The EUT has following accessories.

NO.	PRODUCT	BRAND	MODEL	DESCRIPTION	REMARK
1	Power Adapter	Delta	TC P300	I/P: 100-240Vac, 50-60Hz, 0.2A O/P: 5Vdc, 1A	-
2			TC U250		-
3		Emerson	TC U250		-
4	USB cable	MEC	DC M410	1.4m shielded cable without core (For data transmission & charging use)	For TC P300 only
5		Foxlink			For TC U250 only
6	Battery	HT ENERGY	BB96100	Rating: 3.7Vdc, 1300mAh	See NOTE*
7			BTR6300B		
8		Formosa	BB96100		
9			BTR6300B		

NOTE*: Two models of battery are electrically identical, different model names are for marketing purpose. Therefore, we pre-tested two manufacturers and HT ENERGY battery was found to be the worst case for final test.

5. MEID code: A1000007EE

6. The above EUT information was declared by manufacturer and for more detailed features description, please refer to the manufacturer's specifications or User's Manual.

3.2 DESCRIPTION OF TEST MODES

1151 channels are provided to this EUT in the CDMA band. Therefore, the low, middle and high channels are chosen for testing.

	CHANNEL	FREQUENCY	TX MODE
LOW	25	1851.25 MHz	SO32
MIDDLE	600	1880.00 MHz	SO32
HIGH	1175	1908.75 MHz	SO32

NOTE:

1. Below 1 GHz, the channel 25, 600 and 1175 were pre-tested in chamber. The channel 25 was the worst case and chosen for final test.
2. Above 1 GHz, the channel 25, 600 and 1175 were tested individually.
3. The channel space is 0.05MHz.
4. In this report, CDMA2000 (SO32) as the worst case for all test items, therefore, only the data was recorded in the following section.

3.2.1 CONFIGURATION OF SYSTEM UNDER TEST

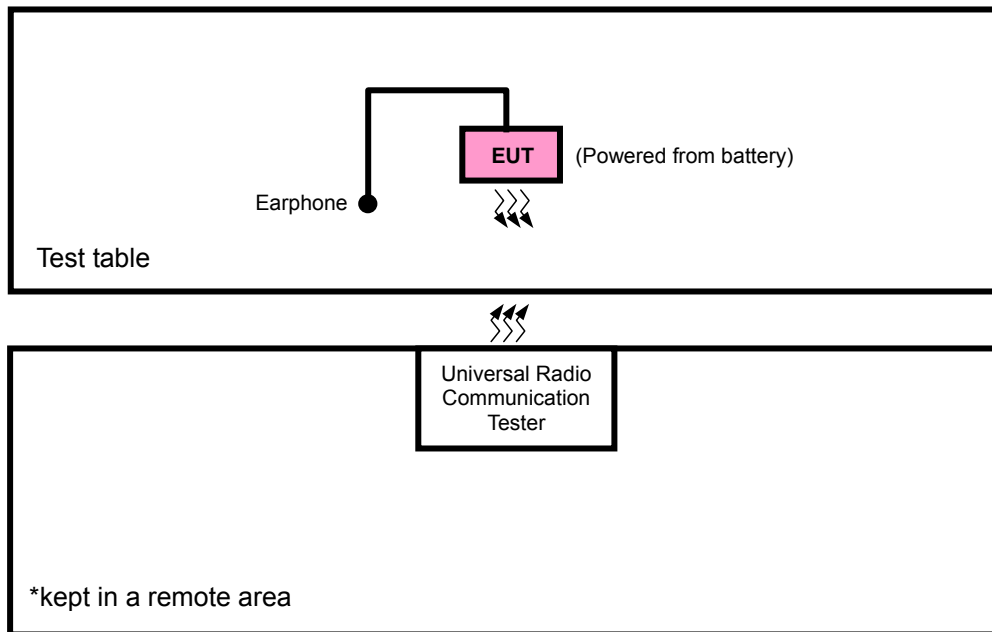



3.2.2 TEST MODE APPLICABILITY AND TESTED CHANNEL DETAIL

EUT CONFIGURE MODE	APPLICABLE TO							DESCRIPTION
	OP	FS	OB	BE	CE	RE<1G	RE≥1G	
-	√	√	√	√	√	√	√	-

Where **OP**: Output power **FS**: Frequency stability
OB: Occupied bandwidth **BE**: Band edge
CE: Conducted spurious emissions **RE<1G**: Radiated emission below 1GHz
RE≥1G: Radiated emission above 1GHz

OUTPUT POWER MEASUREMENT:

- Pre-Scan has been conducted to determine the worst-case mode from all possible combinations between available modulations, XYZ axis and antenna ports (if EUT with antenna diversity architecture).
- Following channel(s) was (were) selected for the final test as listed below.

AVAILABLE CHANNEL	TESTED CHANNEL	MODULATION TECHNOLOGY	AXIS
25 to 1175	25, 600, 1175	CDMA	Z

FREQUENCY STABILITY MEASUREMENT:

- Pre-Scan has been conducted to determine the worst-case mode from all possible combinations between available modulations and antenna ports (if EUT with antenna diversity architecture).
- Following channel(s) was (were) selected for the final test as listed below.

AVAILABLE CHANNEL	TESTED CHANNEL	MODULATION TECHNOLOGY
25 to 1175	600	CDMA

OCCUPIED BANDWIDTH MEASUREMENT:

- Pre-Scan has been conducted to determine the worst-case mode from all possible combinations between available modulations and antenna ports (if EUT with antenna diversity architecture).
- Following channel(s) was (were) selected for the final test as listed below.

AVAILABLE CHANNEL	TESTED CHANNEL	MODULATION TECHNOLOGY
25 to 1175	25, 600, 1175	CDMA



A D T

BAND EDGE MEASUREMENT:

- Pre-Scan has been conducted to determine the worst-case mode from all possible combinations between available modulations and antenna ports (if EUT with antenna diversity architecture).
- Following channel(s) was (were) selected for the final test as listed below.

AVAILABLE CHANNEL	TESTED CHANNEL	MODULATION TECHNOLOGY
25 to 1175	25, 1175	CDMA

CONDUCTED SPURIOUS EMISSIONS MEASUREMENT:

- Pre-Scan has been conducted to determine the worst-case mode from all possible combinations between available modulations and antenna ports (if EUT with antenna diversity architecture).
- Following channel(s) was (were) selected for the final test as listed below.

AVAILABLE CHANNEL	TESTED CHANNEL	MODULATION TECHNOLOGY
25 to 1175	25, 600, 1175	CDMA

RADIATED EMISSION MEASUREMENT (BELOW 1 GHz):

- Pre-Scan has been conducted to determine the worst-case mode from all possible combinations between available modulations, XYZ axis and antenna ports (if EUT with antenna diversity architecture).
- Following channel(s) was (were) selected for the final test as listed below.

AVAILABLE CHANNEL	TESTED CHANNEL	MODULATION TECHNOLOGY	AXIS
25 to 1175	25	CDMA	Z

RADIATED EMISSION MEASUREMENT (ABOVE 1 GHz):

- Pre-Scan has been conducted to determine the worst-case mode from all possible combinations between available modulations, XYZ axis and antenna ports (if EUT with antenna diversity architecture).
- Following channel(s) was (were) selected for the final test as listed below.

AVAILABLE CHANNEL	TESTED CHANNEL	MODULATION TECHNOLOGY	AXIS
25 to 1175	25, 600, 1175	CDMA	Z



A D T

3.3 GENERAL DESCRIPTION OF APPLIED STANDARDS

The EUT is a RF product. According to the specifications of the manufacturer, it must comply with the requirements of the following standards:

FCC 47 CFR Part 2

FCC 47 CFR Part 24

ANSI C63.4-2003

ANSI/TIA/EIA-603-C 2004

NOTE: All test items have been performed and recorded as per the above standards.

3.4 DESCRIPTION OF SUPPORT UNITS

The EUT has been tested as an independent unit together with other necessary accessories or support units. The following support units or accessories were used to form a representative test configuration during the tests.

NO.	PRODUCT	BRAND	MODEL NO.	SERIAL NO.	CAL. DATE
1	EARPHONE	NA	NA	NA	NA
2	UNIVERSAL RADIO COMMUNICATION TESTER	R&S	CMU200	104484	Feb. 02, 2010

NO.	SIGNAL CABLE DESCRIPTION OF THE ABOVE SUPPORT UNITS
1	1.3m non-shielded without core
2	NA

NOTE:

1. All power cords of the above support units are non shielded (1.8m).
2. Item 2 acted as a communication partners to transfer data.
3. Item 1 was supplied from the client.



A D T

4 TEST TYPES AND RESULTS

4.1 OUTPUT POWER MEASUREMENT

4.1.1 LIMITS OF OUTPUT POWER MEASUREMENT

The radiated peak output power shall be according to the specific rule Part 24.232(b) that “Mobile / Portable station are limited to 2 watts e.i.r.p” and 24.232(c) specific that “Peak transmit power must be measure over any interval of continuous transmission using instrumentation calibration in terms of rms-equivalent voltage.”



4.1.2 TEST INSTRUMENTS

DESCRIPTION & MANUFACTURER	MODEL NO.	SERIAL NO.	DATE OF CALIBRATION	DUE DATE OF CALIBRATION
Test Receiver ROHDE & SCHWARZ	ESI7	100033	Jul. 06, 2009	Jul. 05, 2010
Spectrum Analyzer ROHDE & SCHWARZ	FSP40	100076	May 26, 2009	May 25, 2010
BILOG Antenna SCHWARZBECK	VULB9168	9168-160	Apr. 27, 2009	Apr. 26, 2010
HORN Antenna SCHWARZBECK	9120D	9120D-209	Jul. 01, 2009	Jun. 30, 2010
HORN Antenna SCHWARZBECK	BBHA 9170	BBHA9170243	Dec. 25, 2009	Dec. 24, 2010
Preamplifier Agilent	8447D	2944A10633	Nov. 10, 2009	Nov. 09, 2010
Preamplifier Agilent	8449B	3008A01964	Nov. 09, 2009	Nov. 08, 2010
RF signal cable HUBER+SUHNNER	SUCOFLEX 104	238141/4	May 13, 2009	May 12, 2010
RF signal cable HUBER+SUHNNER	SUCOFLEX 104	12738/6	May 13, 2009	May 12, 2010
Software ADT.	ADT_Radiated_ V7.6.15.9.2	NA	NA	NA
Antenna Tower inn-co GmbH	MA 4000	013303	NA	NA
Antenna Tower Controller inn-co GmbH	CO2000	017303	NA	NA
Turn Table ADT.	TT100.	TT93021703	NA	NA
Turn Table Controller ADT.	SC100.	SC93021703	NA	NA

- NOTE:**
1. The calibration interval of the above test instruments is 12 months and the calibrations are traceable to NML/ROC and NIST/USA.
 2. The test was performed in HwaYa Chamber 3.
 3. The horn antenna and HP preamplifier (model: 8449B) are used only for the measurement of emission frequency above 1GHz if tested.
 4. The FCC Site Registration No. is 988962.
 5. The IC Site Registration No. is IC 7450F-3.

4.1.3 TEST PROCEDURES

- a. The power was measured with R&S Spectrum Analyzer. All measurements were done at 3 channels: 25, 600 and 1175 (low, middle and high operational frequency range.)
- b. The conducted peak output power used the power splitter via EUT RF power connector between simulation base station and spectrum analyzer. The path loss included the splitter loss, cable loss and 20dB pad loss. The spectrum set RB/VB 3MHz, then read peak power value and record to the test. (All transmitted path loss shall be considered in the test report data.)
- c. Substitution method is used for E.I.R.P measurement. In the semi-anechoic chamber, EUT placed on the 0.8m height of Turn Table, rotated the table around 360 degrees to search the maximum radiation power and receiver antenna shall be rotated vertical and horizontal polarization and moved height from 1m to 4m to find the maximum polar radiated power. The “Read Value” is the spectrum reading the maximum power value.
- d. The substitution horn antenna is substituted for EUT at the same position and signals generator export the CW signal to the substitution antenna via a TX cable. Rotated the Turn Table and moved receiving antenna to find the maximum radiation power. Adjust output power level of S.G to get a Value of spectrum reading equal to “Read Value “ of step b. Record the power level of S.G
- e. $EIRP = \text{Output power level of S.G} - \text{TX cable loss} + \text{Antenna gain of substitution horn.}$

NOTE: The resolution bandwidth and video bandwidth of test receiver/spectrum analyzer is 3MHz/10MHz.

4.1.4 TEST SETUP

EIRP POWER MEASUREMENT:

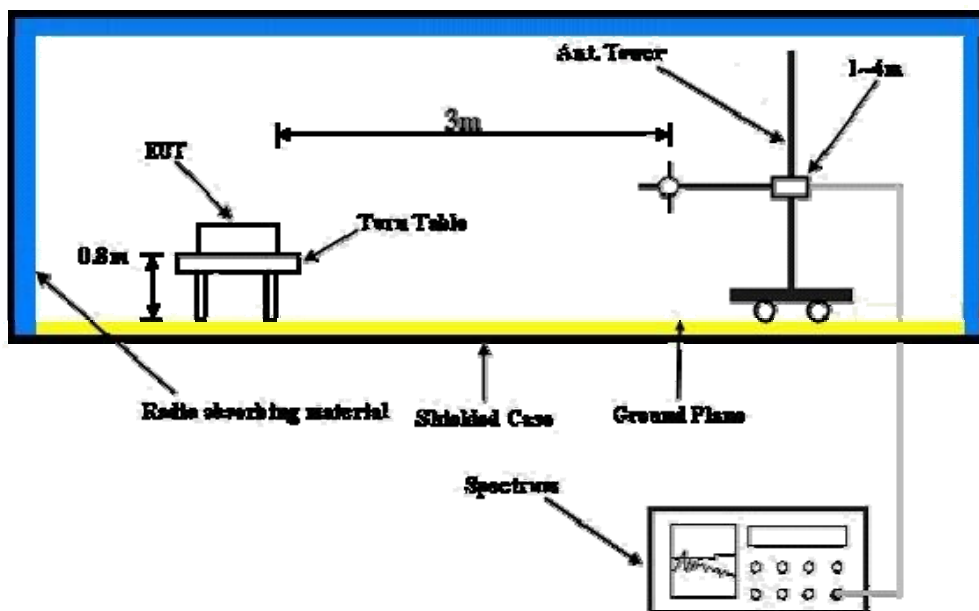

For the actual test configuration, please refer to the attached file (Test Setup Photo).

CONDUCTED POWER MEASUREMENT:

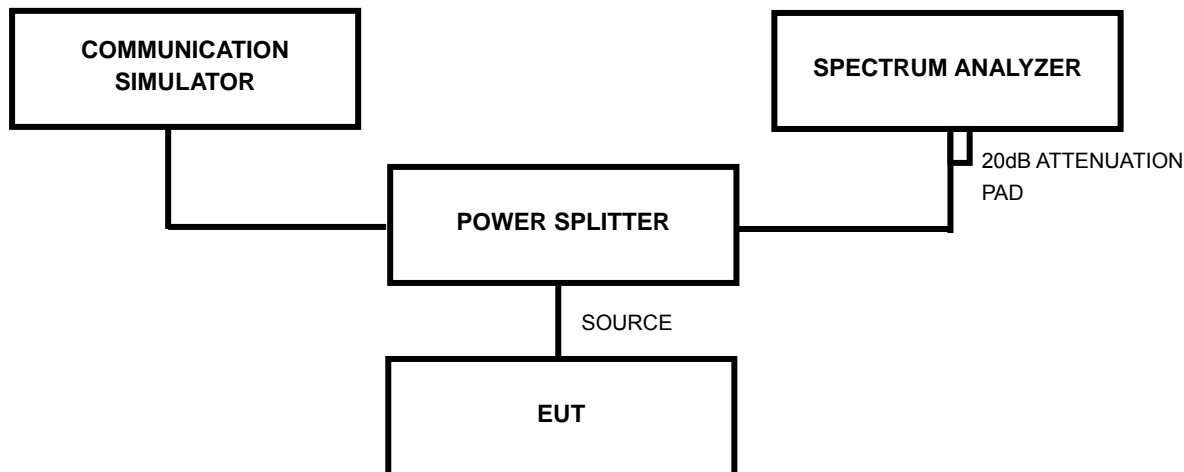

For the actual test configuration, please refer to the attached file (Test Setup Photo).

4.1.5 EUT OPERATING CONDITIONS

- a. The EUT makes a phone call to the communication simulator.
- b. The communication simulator station system controlled an EUT to export maximum output power under transmission mode and specific channel frequency.



A D T

4.1.6 TEST RESULTS

MODE	TX connected	DETECTOR FUNCTION	Average
INPUT POWER (SYSTEM)	120Vac, 60Hz	ENVIRONMENTAL CONDITIONS	23deg. C, 63%RH, 982hPa
TESTED BY	Dean Wang		

WORST CASE CONDUCTED POWER OF 1x EV-DO								
CHANNEL	FREQ. (MHz)	Revision A	Release 0	CORR. FACTOR (dB)	Revision A		Release 0	
		RAW VALUE (dBm)			OUTPUT POWER			
		dBm	mW		dBm	mW		
25	1851.25	18.50	18.60	4.50	23.00	199.5	23.10	204.2
600	1880.00	18.70	18.80	4.50	23.20	208.9	23.30	213.8
1175	1908.75	18.50	18.50	4.50	23.00	199.5	23.00	199.5

CONDUCTED POWER (1x EV-DO)							
CHANNEL	FREQ. (MHz)	Revision A			Release 0		
		RETAP: 128kbps (dBm)	RETAP: 2048kbps (dBm)	RETAP: 12288kbps (dBm)	EVDO-UL: 9.6kbps (dBm)	EVDO-UL: 38.4kbps (dBm)	EVDO-UL: 153.6kbps (dBm)
25	1851.25	23.00	23.00	22.90	23.00	23.10	23.00
600	1880.00	23.20	23.10	23.10	23.20	23.30	23.30
1175	1908.75	23.00	23.00	22.90	23.00	23.00	23.10

CDMA 2000 CONDUCTED POWER													
CHAN.	FREQ. (MHz)	CDMA 2000	RAW VALUE (dBm)					CORR. FACTOR (dB)	OUTPUT POWER (dBm)				
		RC	SO2	SO55	TDSO SO32 (FCH)	TDSO SO32 (FCH+SCH)	SO3		SO2	SO55	TDSO SO32 (FCH)	TDSO SO32 (FCH+SCH)	SO3
25	1851.25	RC1	18.82	18.92	-	-	19.11	4.50	23.32	23.42	-	-	23.61
		RC3	19.03	19.03	19.04	19.02	18.93	4.50	23.53	23.53	23.54	23.52	23.43
600	1880.00	RC1	19.32	19.32	-	-	19.22	4.50	23.82	23.82	-	-	23.72
		RC3	19.36	19.37	19.39	19.23	19.31	4.50	23.86	23.87	23.89	23.73	23.81
1175	1908.75	RC1	18.84	19.02	-	-	18.92	4.50	23.34	23.52	-	-	23.42
		RC3	19.04	19.07	19.08	18.96	18.93	4.50	23.54	23.57	23.58	23.46	23.43

- REMARKS:**
1. Peak Output Power (dBm) = Raw Value (dBm) + Correction Factor (dB).
 2. Correction Factor (dB) = Power Splitter Loss (dB) + Cable Loss (dB).
 3. The value in bold is the worst.



A D T

MODE	TX connected	DETECTOR FUNCTION	Average
INPUT POWER (SYSTEM)	120Vac, 60Hz	ENVIRONMENTAL CONDITIONS	23deg. C, 63%RH, 982hPa
TESTED BY	Dean Wang		

EIRP POWER (1x EV-DO)								
CHANNEL	FREQ. (MHz)	S.G. VALUE (dBm)		CORR. FACTOR (dB)	OUTPUT POWER			
		Revision A	Release 0		Revision A		Release 0	
					dBm	mW	dBm	mW
25	1851.25	17.23	17.27	8.40	25.63	365.6	25.67	369.0
60	1880.00	15.43	15.56	8.60	24.03	252.9	24.16	260.6
1175	1908.75	14.36	14.41	8.50	22.86	193.2	22.91	195.4

EIRP POWER (SO32)					
CHANNEL NO.	FREQUENCY (MHz)	S.G. VALUE (dBm)	CORRECTION FACTOR (dB)	OUTPUT POWER	
				dBm	mW
25	1851.25	17.70	8.40	26.10	407.4
600	1880.00	16.08	8.60	24.68	293.8
1175	1908.75	14.91	8.50	23.41	219.3

- REMARKS:**
1. Peak Output Power (dBm) = S.G (dBm) + Correction Factor (dB).
 2. Correction Factor (dB) = Substitution Antenna Gain (dBi) + Cable Loss (dB).
 3. The value in bold is the worst.



4.2 FREQUENCY STABILITY MEASUREMENT

4.2.1 LIMITS OF FREQUENCY STABILITY MEASUREMENT

According to the FCC part 24.235 shall be tested the frequency stability. The rule is defined that” The frequency stability shall be sufficient to ensure that the fundamental emission stays within the authorized frequency block.” The frequency error rate is according to the JTC standard that the frequency error rate shall be accurate to within 2.5ppm of the received frequency from the base station. The test extreme voltage is according to the 2.1055(d)(1) Vary primary supply voltage from 85 to 115 percent of the nominal value for other than hand carried battery equipment and the extreme temperature rule is comply with the 2.1055(a)(1) $-30^{\circ}\text{C} \sim 50^{\circ}\text{C}$.

4.2.2 TEST INSTRUMENTS

DESCRIPTION & MANUFACTURER	MODEL NO.	SERIAL NO.	DATE OF CALIBRATED	DUE DATE OF CALIBRATION
ROHDE & SCHWARZ Spectrum Analyzer	FSP40	100041	May 13, 2009	May 12, 2010
Hewlett Packard RF cable	8120-6192	01428251	NA	NA
Suhner RF cable	Sucoflex104	204850/4	NA	NA
WIT Standard Temperature & Humidity Chamber	TH-4S-C	W981030	Jun. 29, 2009	Jun. 28, 2010

NOTE: The calibration interval of the above test instruments is 12 months. And the calibrations are traceable to NML/ROC and NIST/USA.

4.2.3 TEST PROCEDURE

- a. Because of the measure the carrier frequency under the condition of the AFC lock, it shall be used the mobile station in the CDMA link mode. This is accomplished with the use of the communication simulator station. The oven room could control the temperatures and humidity. The link channel is the 600.
- b. Power must be removed when changing from one temperature to another or one voltage to another voltage. Power warm up is at least 15 min and power applied should perform before recording frequency error.
- c. EUT is connected the external power supply to control the DC input power. The various Volts from the minimum 3.6 Volts to 4.2 Volts. Each step shall be record the frequency error rate.
- d. The temperature range step is 10 degrees in this test items. All temperature levels shall be hold the $\pm 0.5^{\circ}\text{C}$ during the measurement testing.
- e. The each temperature step shall be at least 0.5 hours, consider the EUT could be test under the stability condition.

NOTE: The frequency error was recorded frequency error from the communication simulator.

4.2.4 TEST SETUP

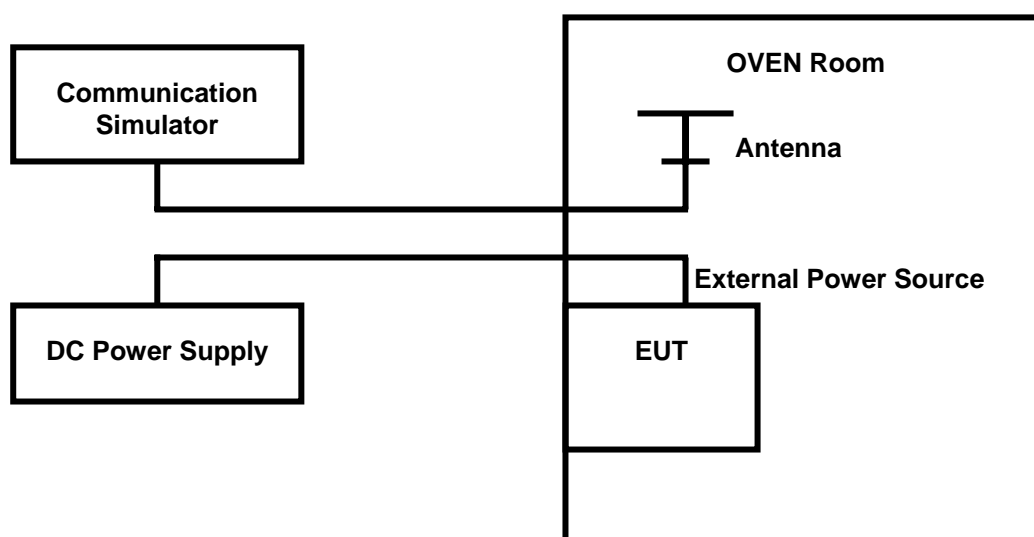



A D T

4.2.5 TEST RESULTS

MODE	Channel 600	ENVIRONMENTAL CONDITIONS	23deg. C, 63%RH, 982hPa
INPUT POWER (SYSTEM)	120Vac, 60Hz	TESTED BY	Dean Wang

AFC FREQUENCY ERROR vs. VOLTAGE			
VOLTAGE (Volts)	FREQUENCY ERROR (Hz)	FREQUENCY ERROR (ppm)	LIMIT (ppm)
4.2	34	0.018	2.5
3.6	28	0.015	2.5

NOTE: The applicant defined the normal working voltage of the battery is from 3.6Vdc to 4.2Vdc.

AFC FREQUENCY ERROR vs. TEMP.			
TEMP. (°C)	FREQUENCY ERROR (Hz)	FREQUENCY ERROR (ppm)	LIMIT (ppm)
50	45	0.024	2.5
40	42	0.022	2.5
30	38	0.020	2.5
20	33	0.018	2.5
10	34	0.018	2.5
0	36	0.019	2.5
-10	39	0.021	2.5
-20	44	0.023	2.5
-30	46	0.024	2.5

4.3 OCCUPIED BANDWIDTH MEASUREMENT

4.3.1 LIMITS OF OCCUPIED BANDWIDTH MEASUREMENT

The occupied bandwidth, that is the frequency bandwidth such that, below its lower and above its upper frequency limits, the mean powers radiated are each equal to 0.5 percent of the total mean power.

4.3.2 TEST INSTRUMENTS

DESCRIPTION & MANUFACTURER	MODEL NO.	SERIAL NO.	DATE OF CALIBRATION	DUE DATE OF CALIBRATION
ROHDE & SCHWARZ Spectrum Analyzer	FSP40	100041	May 13, 2009	May 12, 2010
Mini-Circuits Power Splitter	ZN2PD-9G	NA	Jun. 26, 2009	Jun. 25, 2010
RF cable	SUCOFLEX 104	274403/4	Aug. 21, 2009	Aug. 20, 2010
RF cable	SUCOFLEX 104	250729/4	Aug. 20, 2009	Aug. 19, 2010
RF cable	SUCOFLEX 104	214377/4	Aug. 20, 2009	Aug. 19, 2010
JFW 20dB attenuation	50HF-020-SMA	NA	NA	NA

NOTE: The calibration interval of the above test instruments is 12 months. And the calibrations are traceable to NML/ROC and NIST/USA.

4.3.3 TEST SETUP

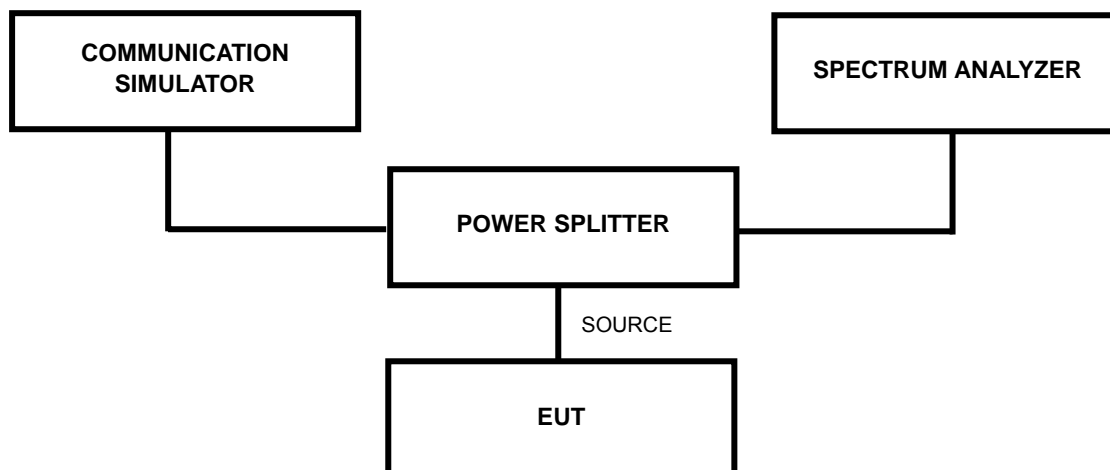



A D T

4.3.4 TEST PROCEDURES

- a. The EUT makes a phone call to the communication simulator. The power was measured with R&S Spectrum Analyzer. All measurements were done at 3 channels, 25, 600 and 1175 (low, middle and high operational frequency range.)
- b. The conducted occupied bandwidth used the power splitter via EUT RF power connector between simulation base station and spectrum analyzer. This splitter loss and cable loss are the worst loss 4.5dB in the transmitted path track.
- c. The communication simulator station system controlled a EUT to export maximum output power under transmission mode and specific channel frequency. Use OBW measurement function of Spectrum analyzer to measure 99 % occupied bandwidth.



A D T

4.3.5 TEST RESULTS

FOR SO32:

CHANNEL	FREQUENCY (MHz)	99% OCCUPIED BANDWIDTH (MHz)
25	1851.25	1.28
600	1880.00	1.28
1175	1908.75	1.28

CH 25

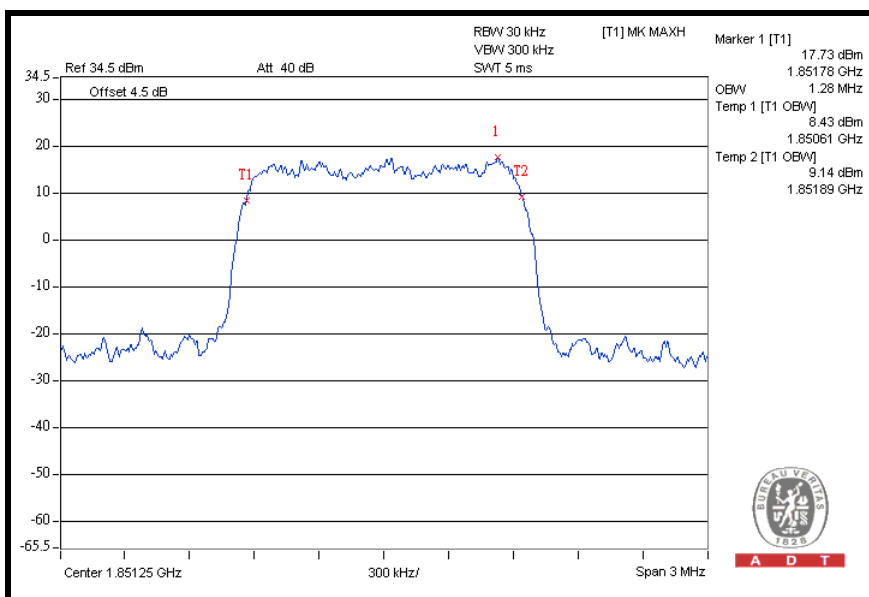



A D T

CH 600

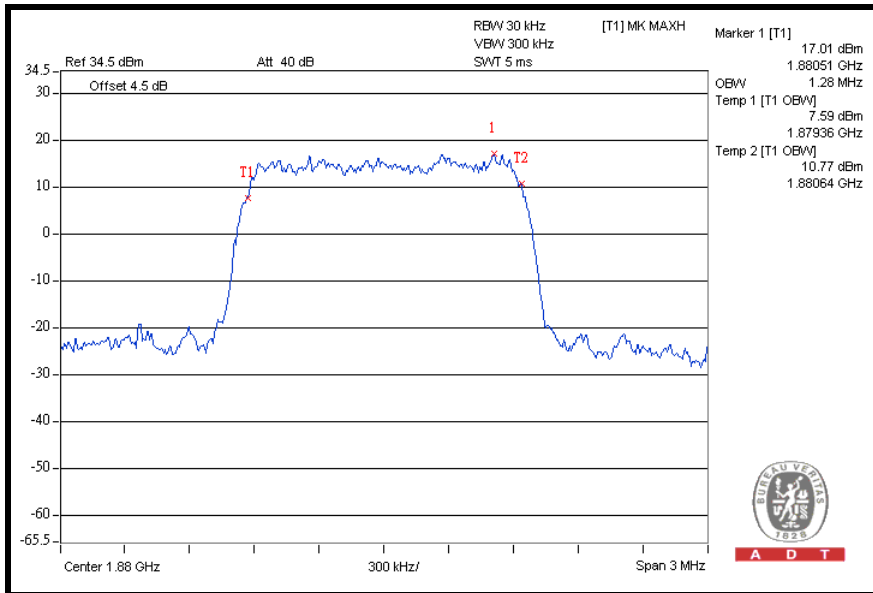

CH 1175

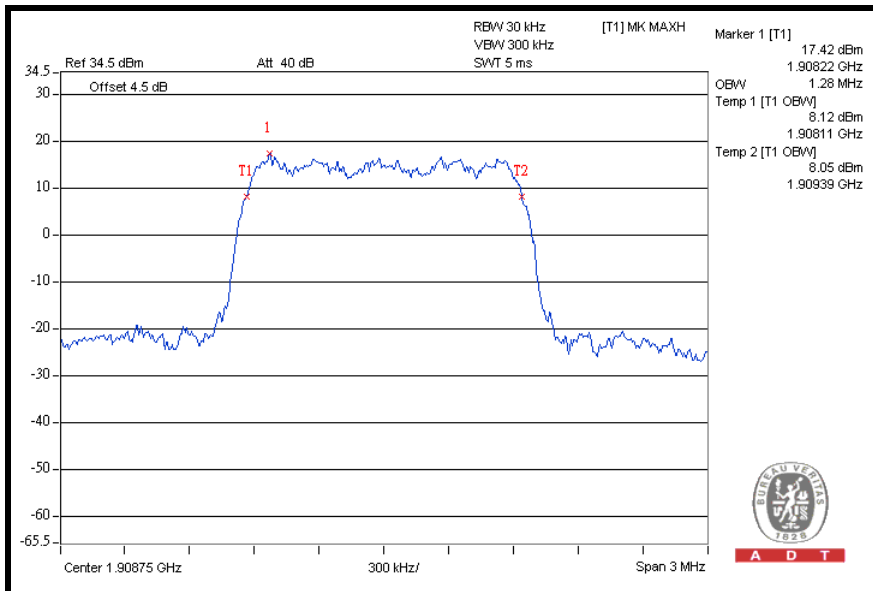



A D T

FOR EV-DO Revision A:

CHANNEL	FREQUENCY (MHz)	99% OCCUPIED BANDWIDTH (MHz)
25	1851.25	1.28
600	1880.00	1.28
1175	1908.75	1.28

CH 25

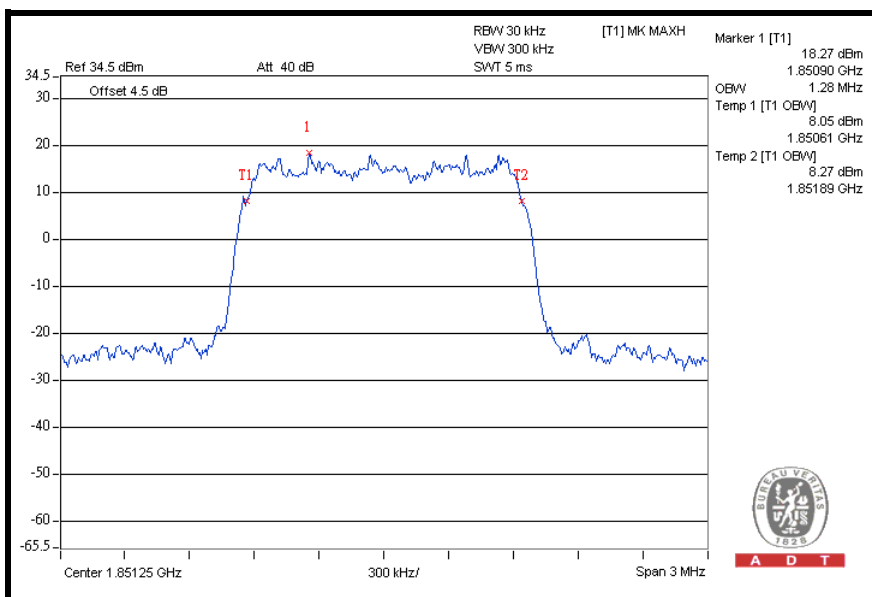

A D T



A D T

CH 600

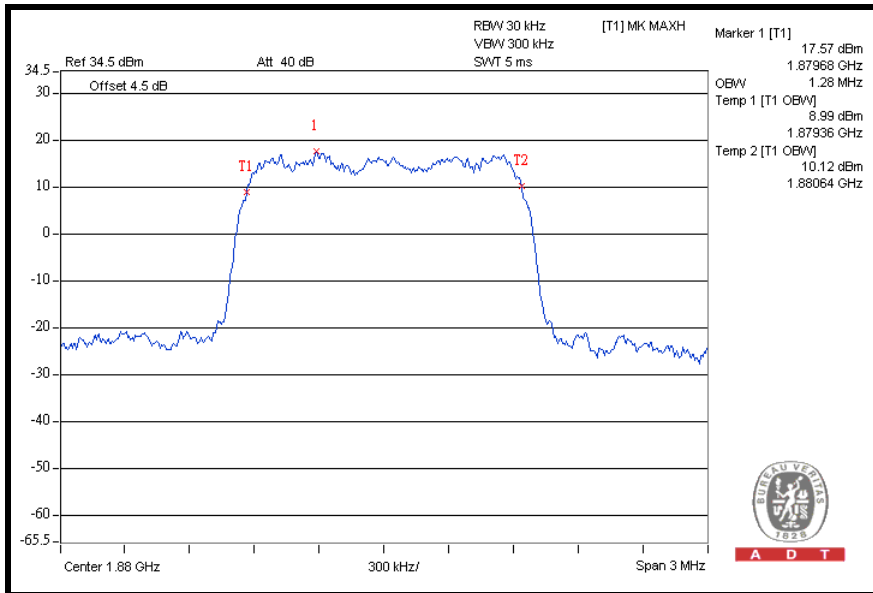

CH 1175

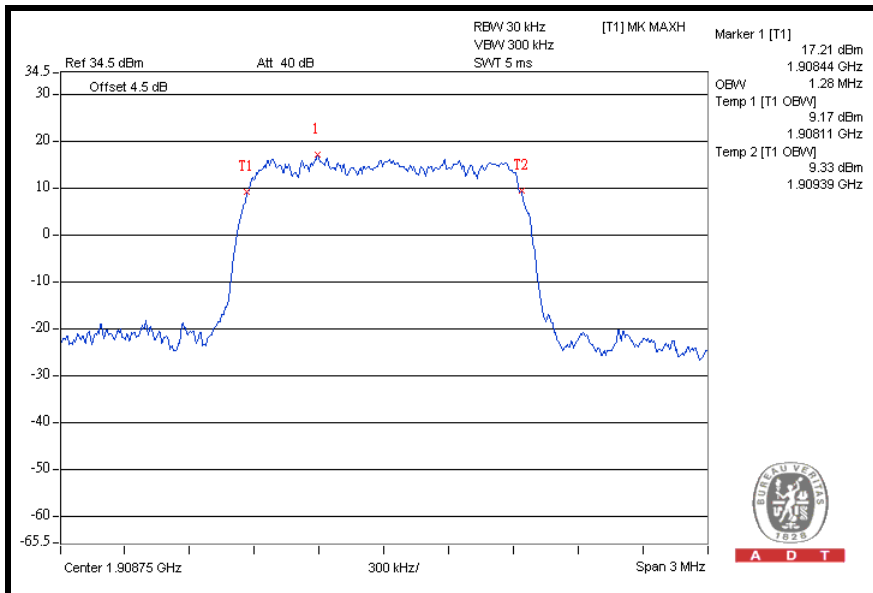



A D T

FOR EV-DO Release 0:

CHANNEL	FREQUENCY (MHz)	99% OCCUPIED BANDWIDTH (MHz)
25	1851.25	1.28
600	1880.00	1.29
1175	1908.75	1.28

CH 25

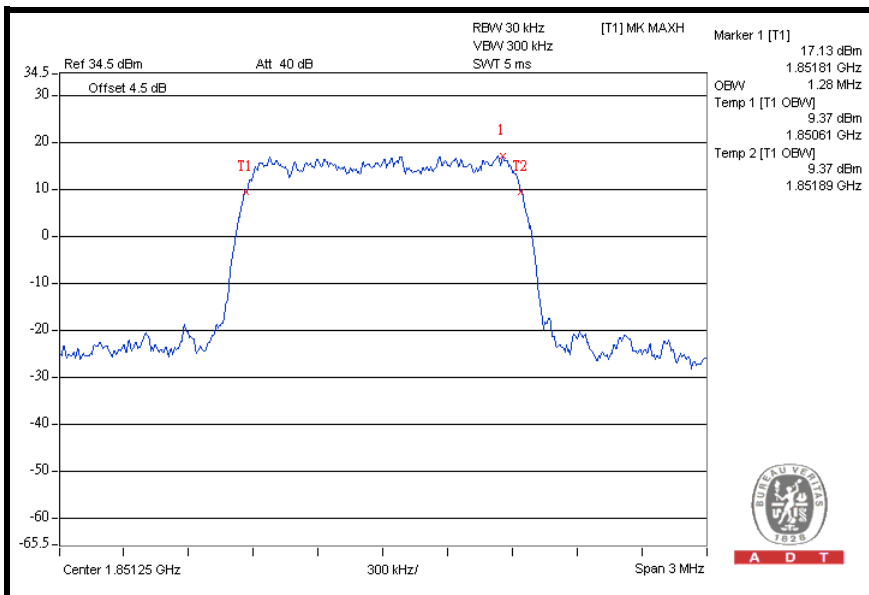



A D T

CH 600

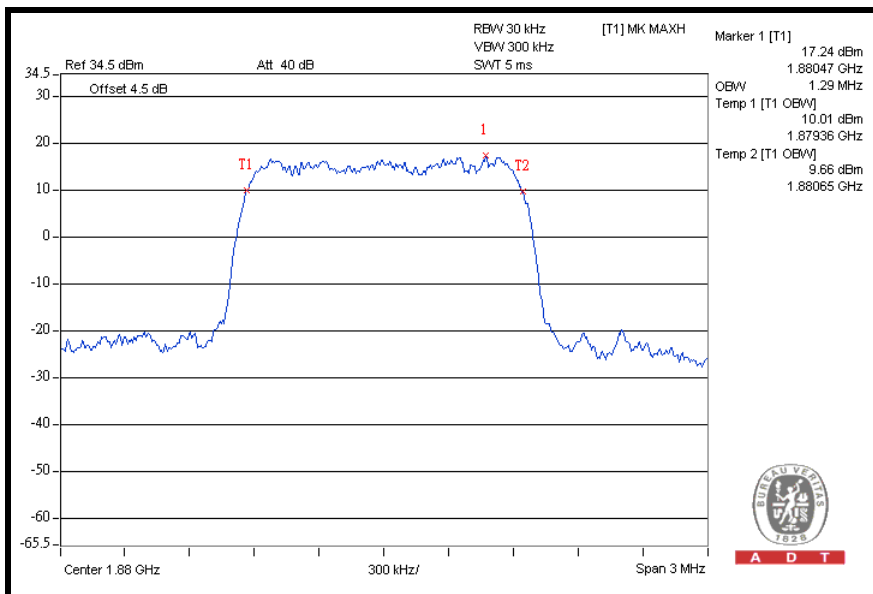

CH 1175

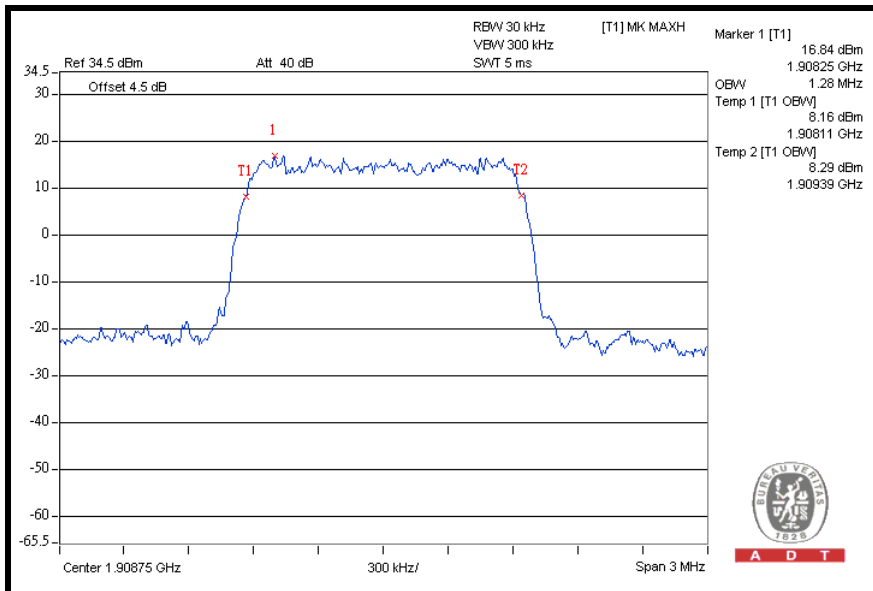

4.4 BAND EDGE MEASUREMENT

4.4.1 LIMITS OF BAND EDGE MEASUREMENT

The PCS frequency bands refer to the FCC 24.229 rule. According to FCC 24.238(a) specified that power of any emission outside of the authorized operating frequency ranges must be attenuated below the transmitting power (P) by a factor of at least $43 + 10 \log(P)$ dB. In the 1 MHz bands immediately outside and adjacent to the frequency block a resolution bandwidth of at least one percent of the emission bandwidth of the fundamental emission of the transmitter may be employed.

4.4.2 TEST INSTRUMENTS

DESCRIPTION & MANUFACTURER	MODEL NO.	SERIAL NO.	DATE OF CALIBRATION	DUE DATE OF CALIBRATION
ROHDE & SCHWARZ Spectrum Analyzer	FSP40	100041	May 13, 2009	May 12, 2010
Mini-Circuits Power Splitter	ZN2PD-9G	NA	Jun. 26, 2009	Jun. 25, 2010
RF cable	SUCOFLEX 104	274403/4	Aug. 21, 2009	Aug. 20, 2010
RF cable	SUCOFLEX 104	250729/4	Aug. 20, 2009	Aug. 19, 2010
RF cable	SUCOFLEX 104	214377/4	Aug. 20, 2009	Aug. 19, 2010
JFW 20dB attenuation	50HF-020-SMA	NA	NA	NA

NOTE: The calibration interval of the above test instruments is 12 months. And the calibrations are traceable to NML/ROC and NIST/USA.

4.4.3 TEST SETUP

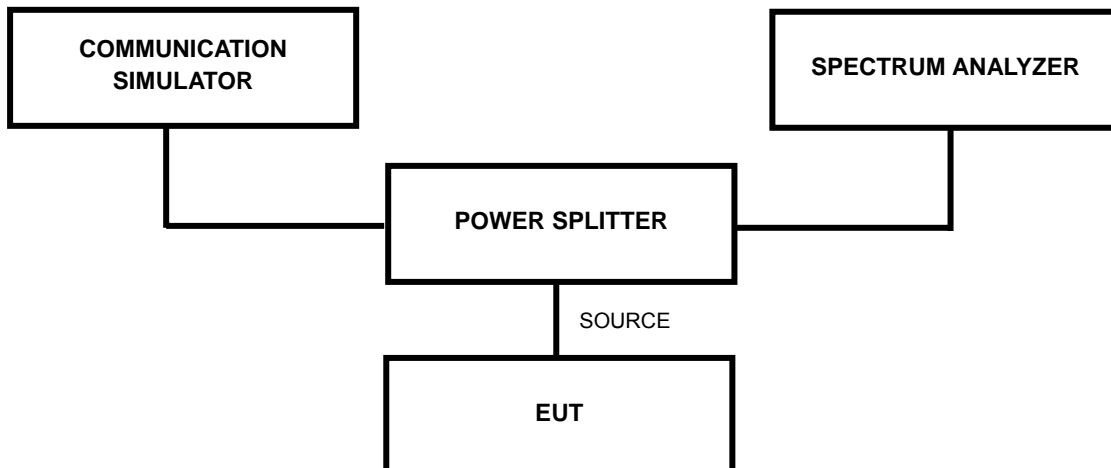



A D T

4.4.4 TEST PROCEDURES

- a. The EUT was set up for the maximum peak power with CDMA link data modulation. The power was measured with R&S Spectrum Analyzer. All measurements were done at 2 channels, 25 and 1175 (low and high operational frequency range.)
- b. The band edge measurement used the power splitter via EUT RF power connector between simulation base station and spectrum analyzer. This splitter loss and cable loss are the worst loss 4.5dB in the transmitted path track.
- c. The center frequency of spectrum is the band edge frequency and span is 3 MHz. RB of the spectrum is 15kHz and VB of the spectrum is 15kHz.
- d. Record the max trace plot into the test report.

4.4.5 EUT OPERATING CONDITION

- a. The EUT makes a phone call to the communication simulator.
- b. The communication simulator station system controlled an EUT to export maximum output power under transmission mode and specific channel frequency.



A D T

4.4.6 TEST RESULTS

FOR SO32:

LOWER BAND EDGE

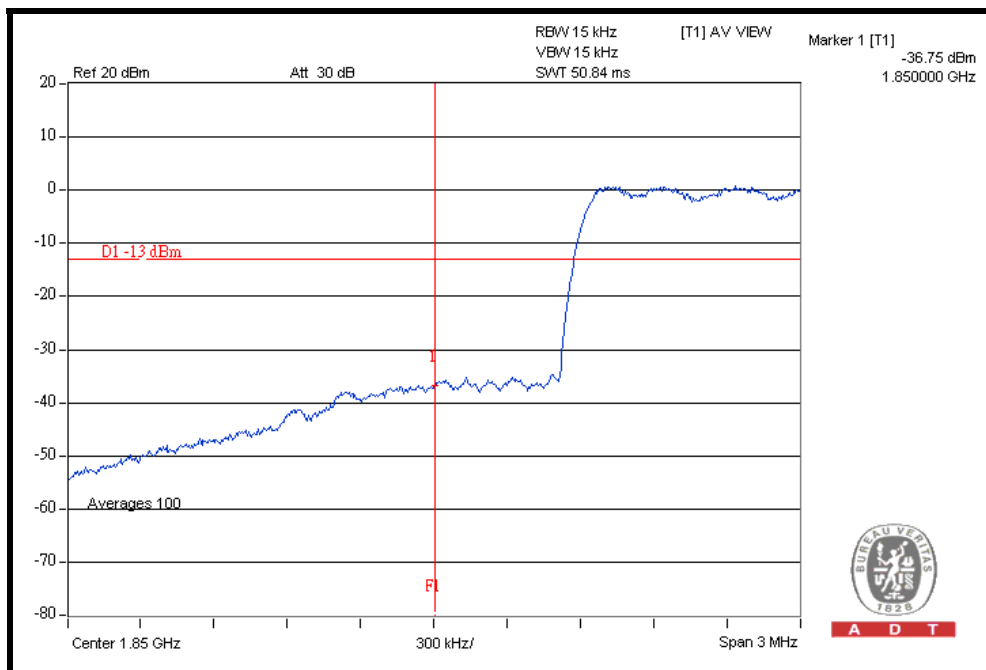

HIGHER BAND EDGE

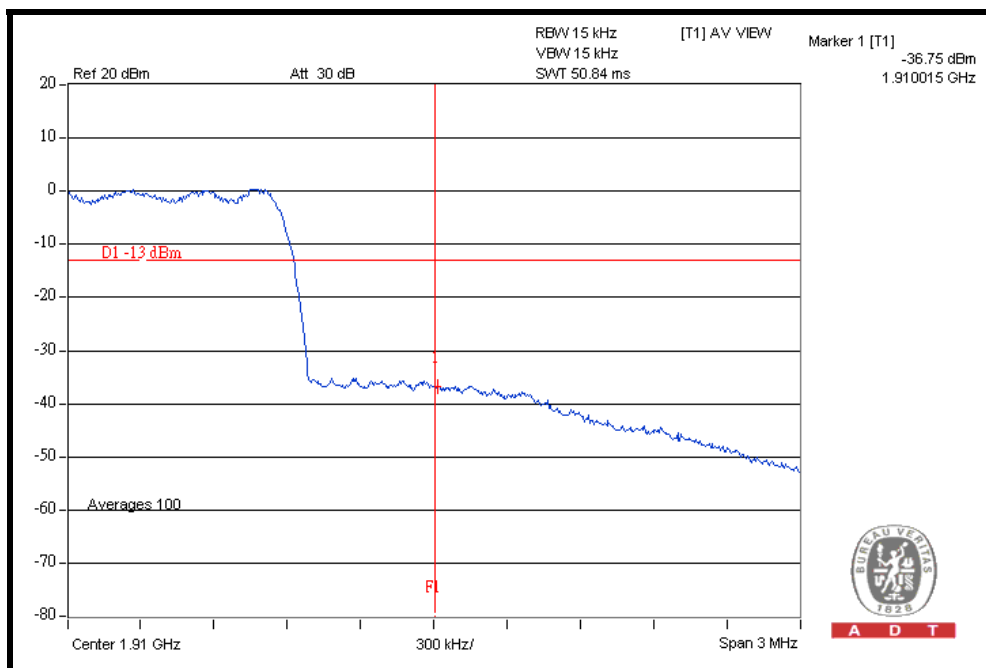



A D T

FOR EV-DO Revision A: LOWER BAND EDGE

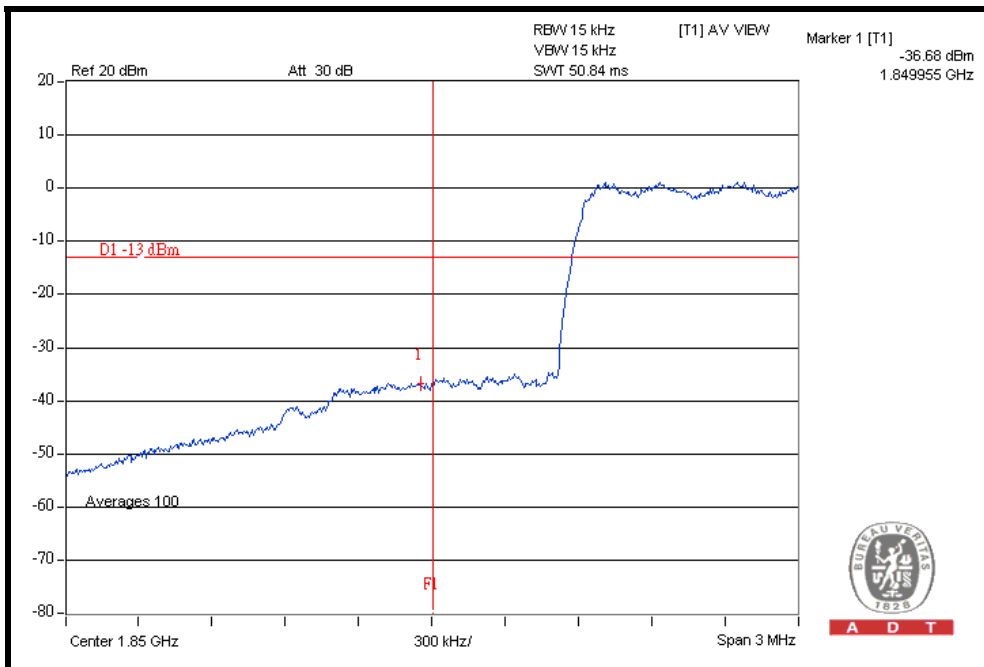

A D T

HIGHER BAND EDGE

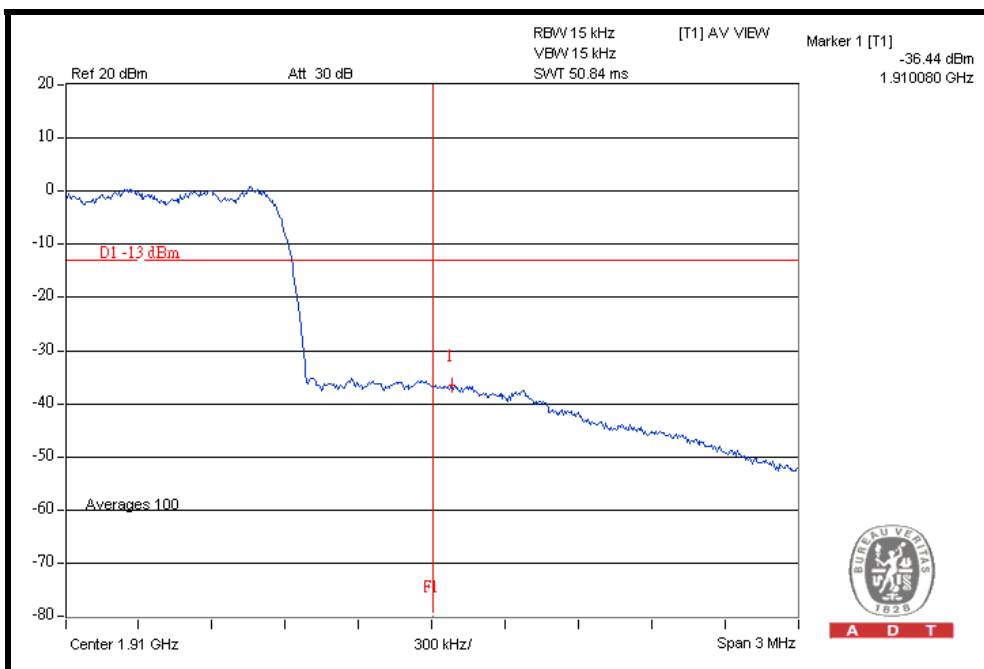

A D T



A D T

FOR EV-DO Release 0: LOWER BAND EDGE

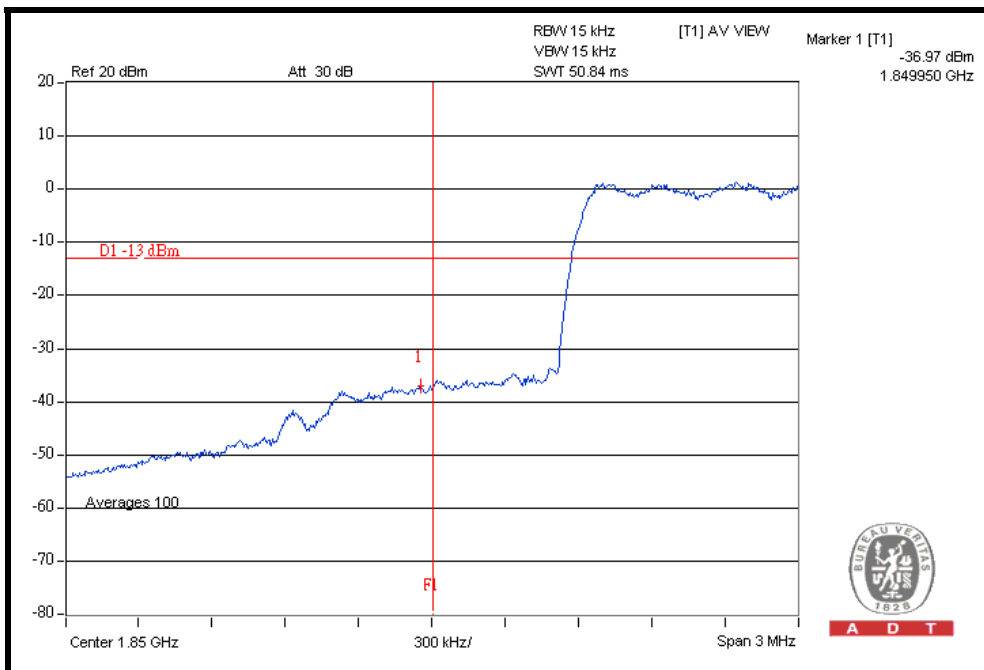

HIGHER BAND EDGE

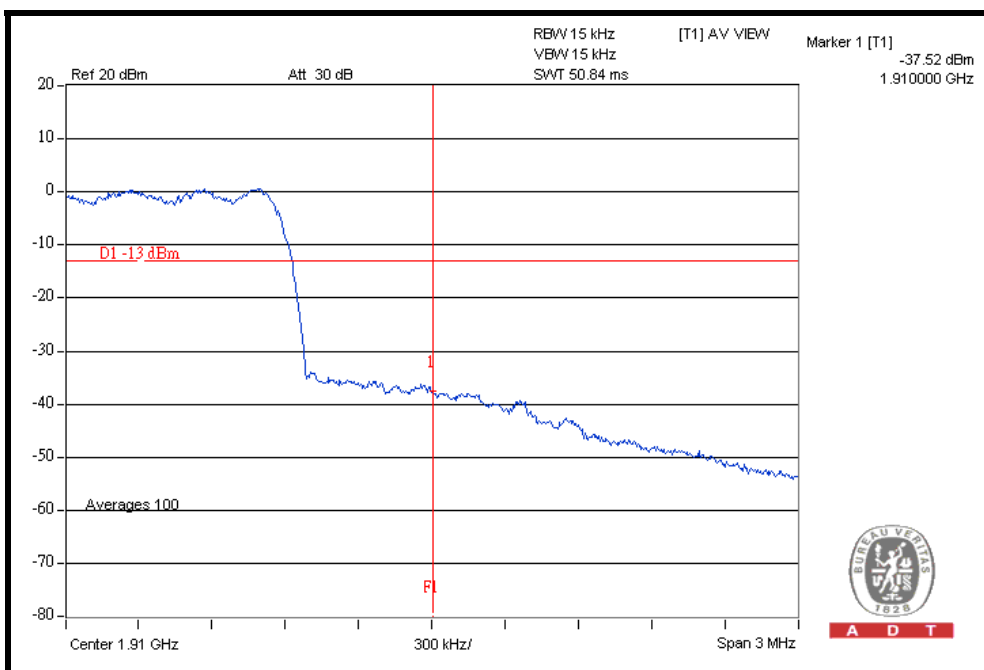



A D T

4.5 CONDUCTED SPURIOUS EMISSIONS

4.5.1 LIMITS OF CONDUCTED SPURIOUS EMISSIONS MEASUREMENT

In the FCC 24.238(a), On any frequency outside a licensee's frequency block within USPCS spectrum, the power of any emission shall be attenuated below the transmitter power (P) by at least $43 + 10 \log (P)$ dB. The limit of emission equal to -13dBm .

4.5.2 TEST INSTRUMENTS

DESCRIPTION & MANUFACTURER	MODEL NO.	SERIAL NO.	DATE OF CALIBRATION	DUE DATE OF CALIBRATION
ROHDE & SCHWARZ Spectrum Analyzer	FSP40	100041	May 13, 2009	May 12, 2010
Wainwright Instruments Band Reject Filter	WRCG 824/849-810/ 863-60/9SS	SN1	Mar. 26, 2009	Mar. 25, 2010
WI Highpass filter	WHK1.5/15G-10ST	SN1	Mar. 31, 2009	Mar. 30, 2010
Mini-Circuits Power Splitter	ZN2PD-9G	NA	Jun. 26, 2009	Jun. 25, 2010
RF cable	SUCOFLEX 104	274403/4	Aug. 21, 2009	Aug. 20, 2010
RF cable	SUCOFLEX 104	250729/4	Aug. 20, 2009	Aug. 19, 2010
RF cable	SUCOFLEX 104	214377/4	Aug. 20, 2009	Aug. 19, 2010
JFW 20dB attenuation	50HF-020-SMA	NA	NA	NA

NOTE: The calibration interval of the above test instruments is 12 months. And the calibrations are traceable to NML/ROC and NIST/USA.

4.5.3 TEST PROCEDURE

- a. The EUT was set up for the maximum peak power with CDMA link data modulation. The power was measured with R&S Spectrum Analyzer. All measurements were done at 3 channels, 25, 600 and 1175 (low, middle and high operational frequency range.)
- b. The conducted spurious emission used the power splitter via EUT RF power connector between simulation base station and spectrum analyzer. This splitter loss and cable loss are the worst loss 4.5dB in the transmitted path track.
- c. When the spectrum scanned from 9kHz to 3GHz, it shall be connected to the band reject filter attenuated the carried frequency. The spectrum set RB=1MHz, VB=3MHz.
- d. When the spectrum scanned from 3GHz to 20GHz, it shall be connected to the high pass filter attenuated the carried frequency. The spectrum set RB=1MHz, VB=3MHz.

4.5.4 TEST SETUP

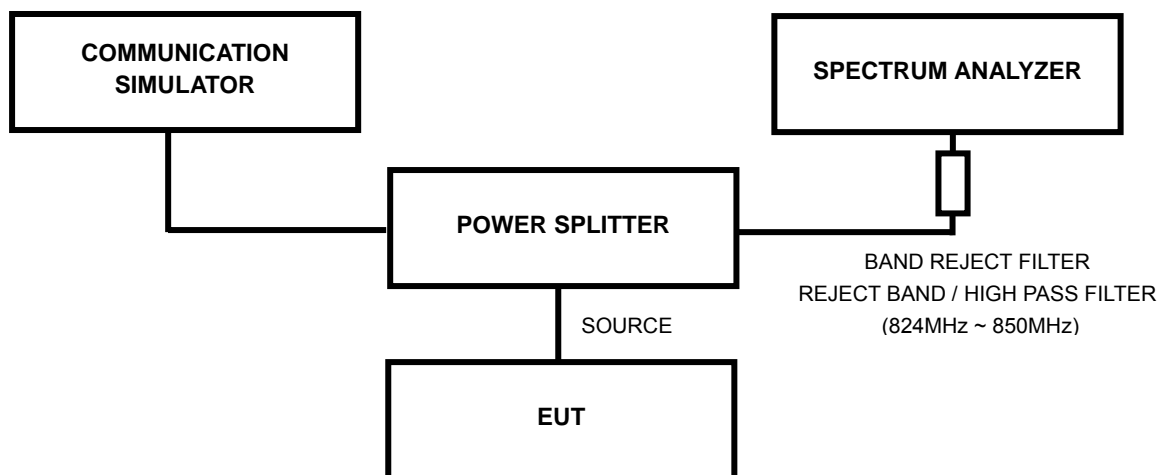

4.5.5 EUT OPERATING CONDITIONS

- a. The EUT makes a phone call to the communication simulator.
- b. The communication simulator station system controlled a EUT to export maximum output power under transmission mode and specific channel frequency.



A D T

4.5.6 TEST RESULTS

CH 25: 9kHz ~ 3GHz

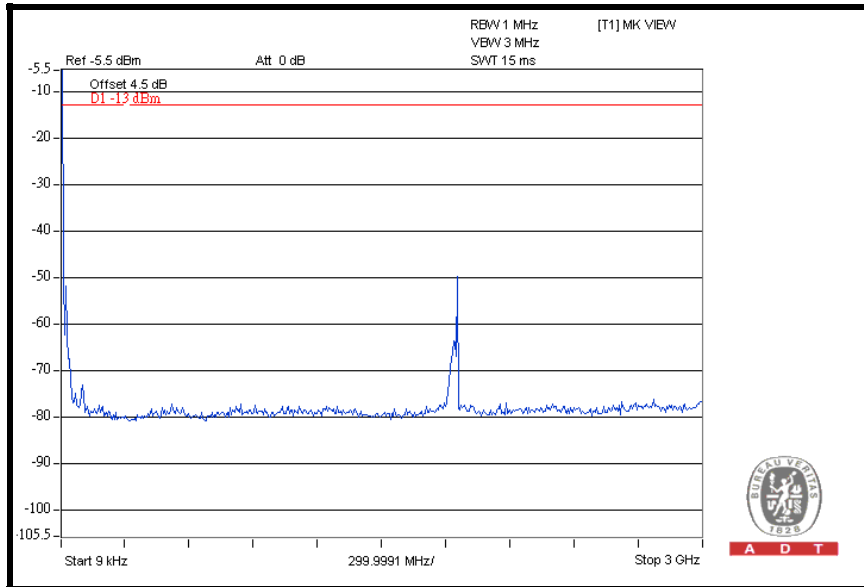

3GHz ~ 10GHz

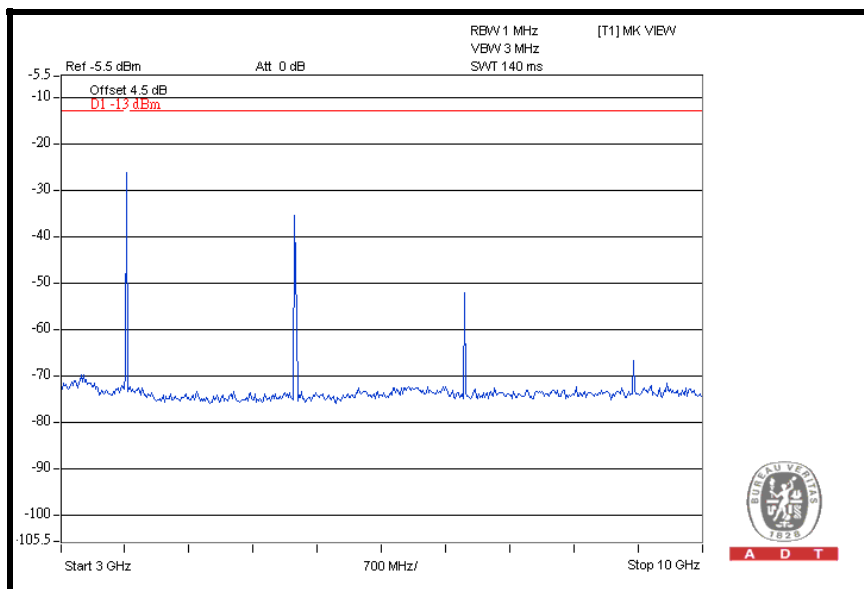



A D T

10GHz ~ 20GHz

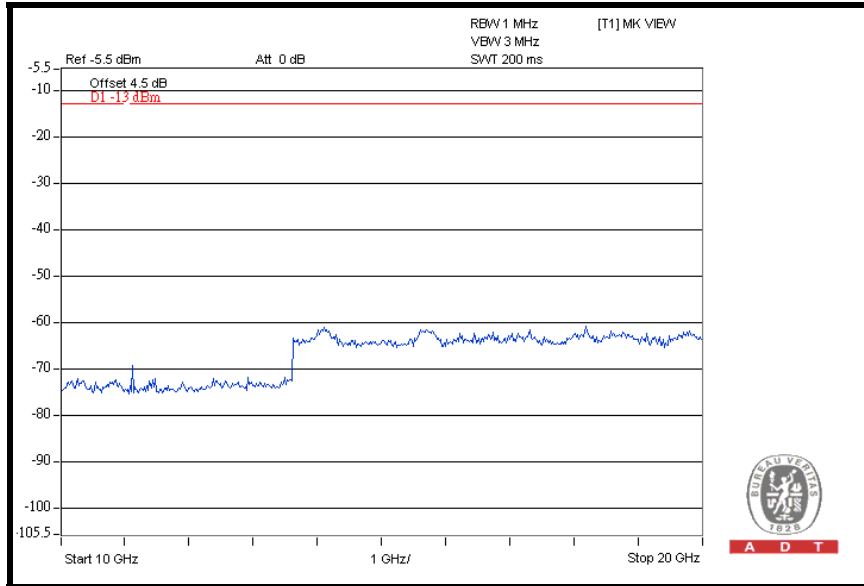

CH 600: 9kHz ~ 3GHz

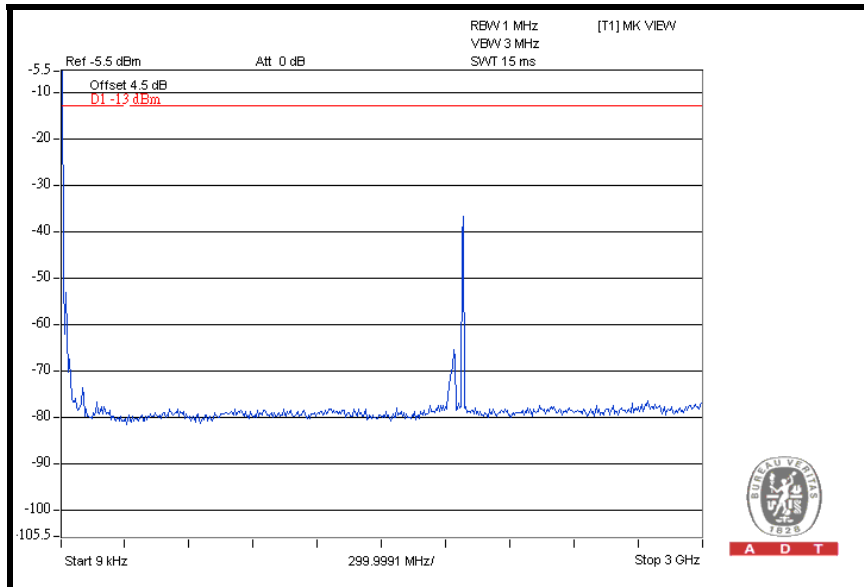



A D T

3GHz ~ 10GHz

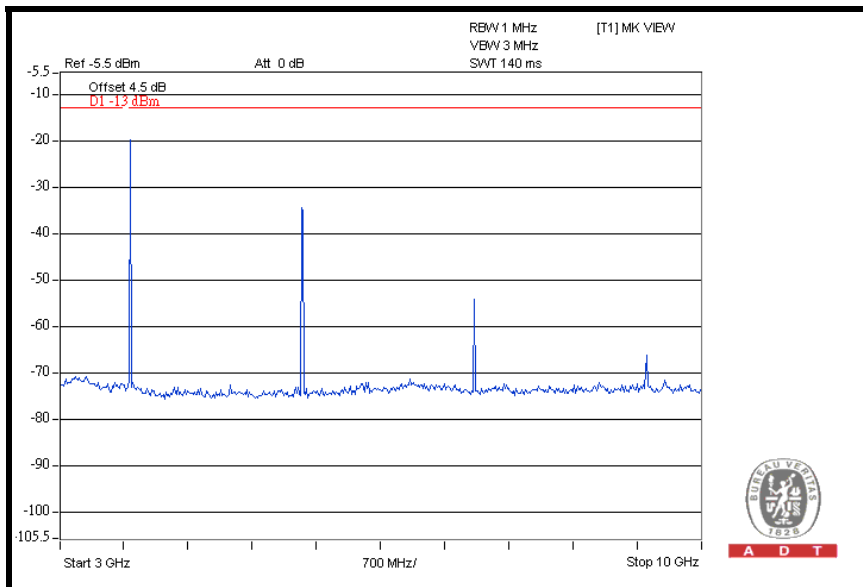

10GHz ~ 20GHz

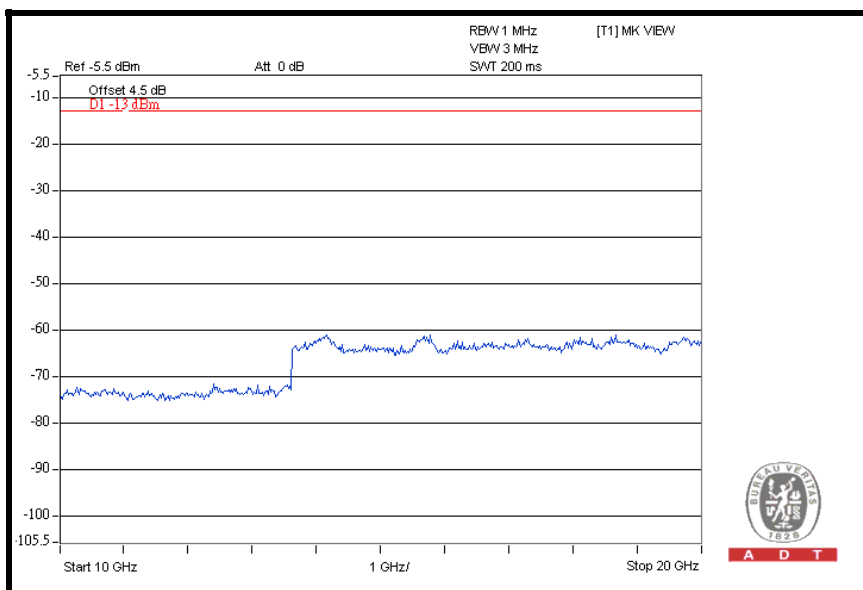



A D T

CH 1175: 9kHz ~ 3GHz

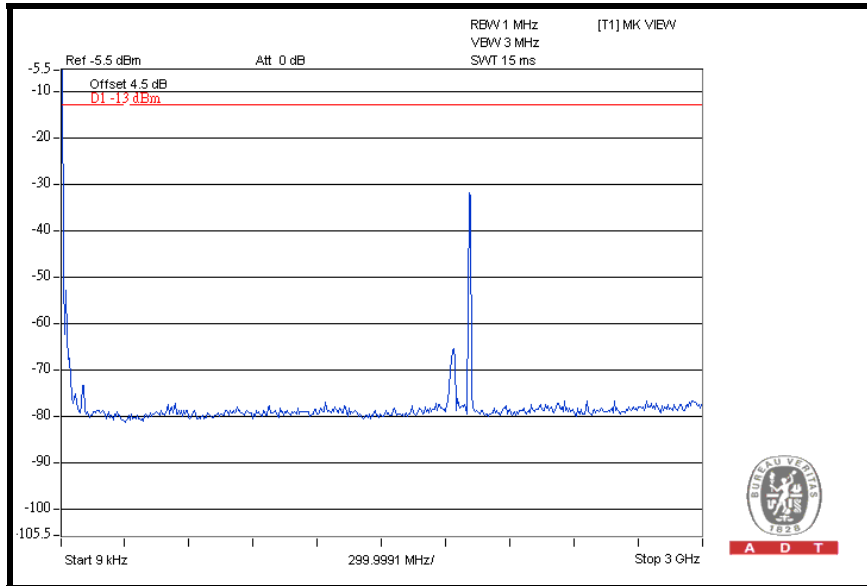

3GHz ~ 10GHz

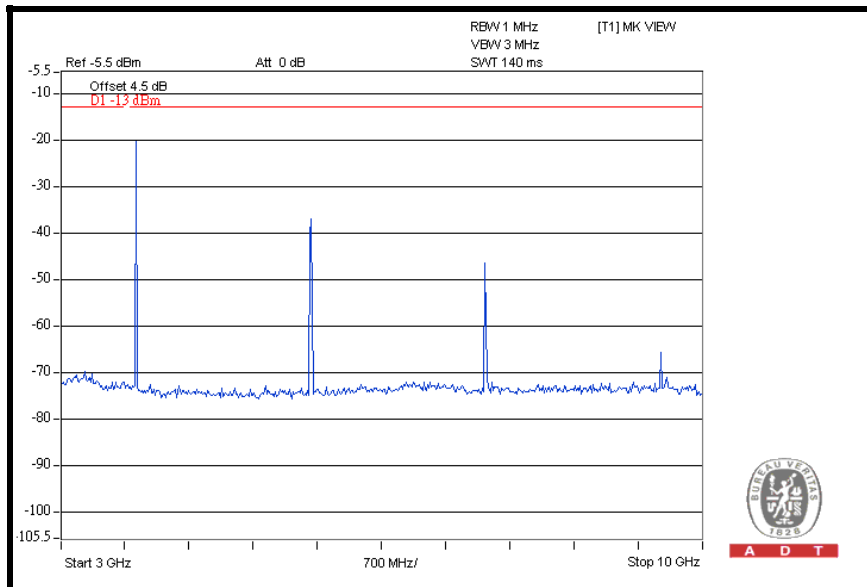



A D T

10GHz ~ 20GHz

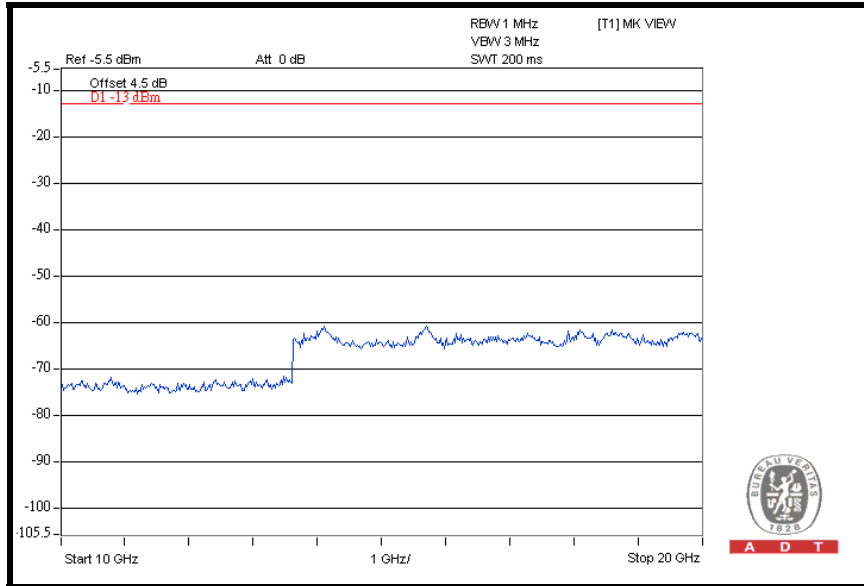



A D T

4.6 RADIATED EMISSION MEASUREMENT (BELOW 1GHz)

4.6.1 LIMITS OF RADIATED EMISSION MEASUREMENT

In the FCC 24.238(a), On any frequency outside a licensee's frequency block within USPCS spectrum, the power of any emission shall be attenuated below the transmitter power (P) by at least $43 + 10 \log (P)$ dB. The limit of emission equal to -13 dBm. So the limit of emission is the same absolute specified line.

LIMIT (dBm)	EQUIVALENT FIELD STRENGTH AT 3m (dBuV/m) (NOTE)
-13	82.2

NOTE: The following formula is used to convert the equipment radiated power to field strength.

$$E = [1000000\sqrt{(30P)}] / 3 \text{ uV/m, where P is Watts.}$$

4.6.2 TEST INSTRUMENTS

Same as 4.1.2.



A D T

4.6.3 TEST PROCEDURES

- a. The EUT was placed on the top of a rotating table 0.8 meters above the ground at a 3 meters semi-anechoic chamber. The table was rotated 360 degrees to determine the position of the highest radiation.
- b. The EUT was set 3 meters away from the interference-receiving antenna, which was mounted on the top of a variable-height antenna tower.
- c. The antenna is a broadband antenna, and its height is varied from one meter to four meters above the ground to determine the maximum value of the field strength. Both horizontal and vertical polarizations of the antenna are set to make the measurement.
- d. For each suspected emission, the EUT was arranged to its worst case and then the antenna was tuned to heights from 1 meter to 4 meters and the rotatable table was turned from 0 degrees to 360 degrees to find the maximum reading.
- e. The test-receiver system was set to Peak Detect Function and Specified Bandwidth with Maximum Hold Mode.
- f. If the emission level of the EUT in peak mode was lower than the limit specified, then testing could be stopped and the peak values of the EUT would be reported. Otherwise the emissions would be re-tested one by one using peak, quasi-peak or average method as specified and then reported in a data sheet.

NOTE: The resolution bandwidth and video bandwidth of test receiver/spectrum analyzer is 1MHz/3MHz.

4.6.4 DEVIATION FROM TEST STANDARD

No deviation

4.6.5 TEST SETUP

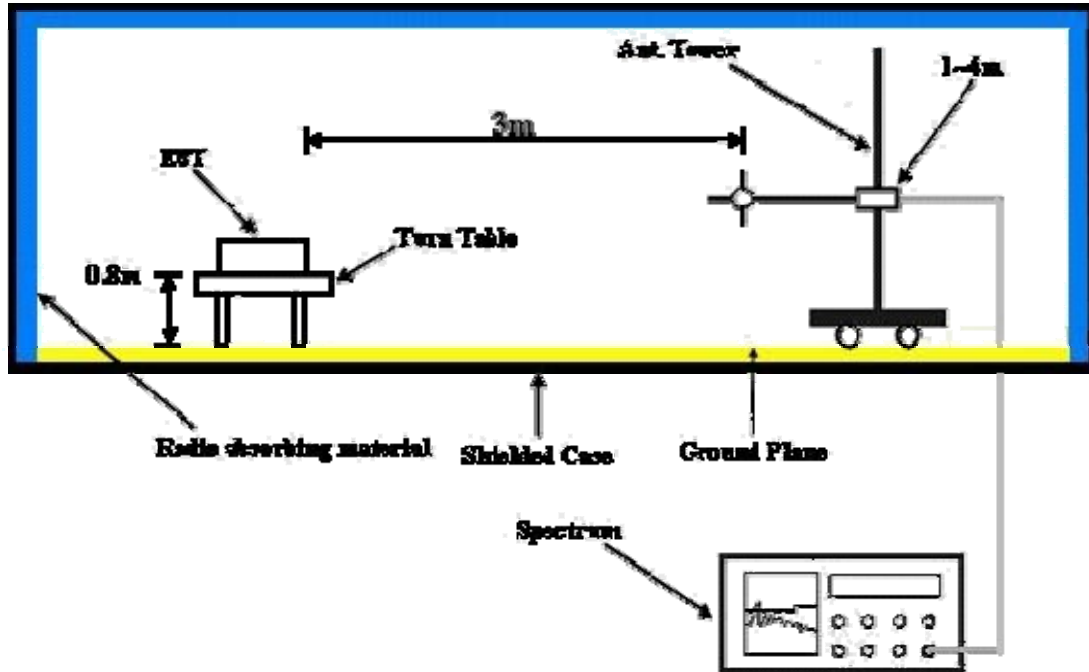

For the actual test configuration, please refer to the attached file (Test Setup Photo).

4.6.6 EUT OPERATING CONDITIONS

- a. The EUT makes a phone call to the communication simulator.
- b. The communication simulator station system controlled an EUT to export maximum output power under transmission mode and specific channel frequency.



A D T

4.6.7 TEST RESULTS

MODE	TX channel 25	FREQUENCY RANGE	Below 1000MHz
ENVIRONMENTAL CONDITIONS	26deg. C, 66%RH, 982hPa	INPUT POWER (SYSTEM)	120Vac, 60Hz
TESTED BY	Lori Chiu		

ANTENNA POLARITY & TEST DISTANCE: HORIZONTAL AT 3 M								
NO.	FREQ. (MHz)	EMISSION LEVEL (dBuV/m)	LIMIT (dBuV/m)	MARGIN (dB)	ANTENNA HEIGHT (m)	TABLE ANGLE (Degree)	RAW VALUE (dBuV)	CORRECTION FACTOR (dB/m)
1	111.64	31.30	82.2	-51.0	1.50 H	10	19.80	11.50
2	121.36	32.10	82.2	-50.2	2.00 H	331	20.60	11.50
3	191.34	38.20	82.2	-44.1	2.00 H	157	27.20	11.00
4	201.06	36.90	82.2	-45.4	1.50 H	328	26.30	10.60
5	294.37	38.10	82.2	-44.2	1.00 H	112	24.30	13.80
6	317.70	33.60	82.2	-48.7	1.00 H	127	19.00	14.60
ANTENNA POLARITY & TEST DISTANCE: VERTICAL AT 3 M								
NO.	FREQ. (MHz)	EMISSION LEVEL (dBuV/m)	LIMIT (dBuV/m)	MARGIN (dB)	ANTENNA HEIGHT (m)	TABLE ANGLE (Degree)	RAW VALUE (dBuV)	CORRECTION FACTOR (dB/m)
1	105.81	42.80	82.2	-39.50	1.50 V	346	31.20	11.60
2	127.19	32.30	82.2	-50.00	1.50 V	85	20.40	11.90
3	150.52	32.20	82.2	-50.10	1.00 V	316	18.10	14.10
4	164.13	33.80	82.2	-48.50	1.50 V	253	19.70	14.10
5	208.84	41.30	82.2	-41.00	1.50 V	226	30.20	11.10
6	222.44	44.80	82.2	-37.50	1.50 V	10	32.80	12.00

NOTE:

1. Emission level (dBuV/m) = Raw Value (dBuV) + Correction Factor (dB).
2. Correction Factor (dB/m) = Antenna Factor (dB/m) + Cable Factor (dB).
3. The other emission levels were very low against the limit.
4. Margin value = Emission level – Limit value.
5. This is valid for all 3 channels.



A D T

4.7 RADIATED EMISSION MEASUREMENT (ABOVE 1GHz)

4.7.1 LIMITS OF RADIATED EMISSION MEASUREMENT

In the FCC 24.238(a), On any frequency outside a licensee's frequency block within USPCS spectrum, the power of any emission shall be attenuated below the transmitter power (P) by at least $43 + 10 \log (P)$ dB. The limit of emission equal to -13dBm .

4.7.2 TEST INSTRUMENTS

Same as 4.1.2.

4.7.3 TEST PROCEDURES

- a. The power was measured with R&S Spectrum Analyzer. All measurements were done at 3 channels: 25, 600 and 1175 (low, middle and high operational frequency range.)
- b. Substitution method is used for E.I.R.P measurement. In the semi-anechoic chamber, EUT placed on the 0.8m height of Turn Table, rotated the table around 360 degrees to search the maximum radiation power and receiver antenna shall be rotated vertical and horizontal polarization and moved height from 1m to 4m to find the maximum polar radiated power. The “Read Value” is the spectrum reading the maximum power value.
- c. The substitution horn antenna is substituted for EUT at the same position and signals generator export the CW signal to the substitution antenna via a TX cable. Rotated the Turn Table and moved receiving antenna to find the maximum radiation power. Adjust output power level of S.G to get a Value of spectrum reading equal to “Read Value “ of step b. Record the power level of S.G
- d. $EIRP = \text{Output power level of S.G} - \text{TX cable loss} + \text{Antenna gain of substitution horn.}$

NOTE: The resolution bandwidth and video bandwidth of test receiver/spectrum analyzer is 1MHz/3MHz.

4.7.4 DEVIATION FROM TEST STANDARD

No deviation

4.7.5 TEST SETUP

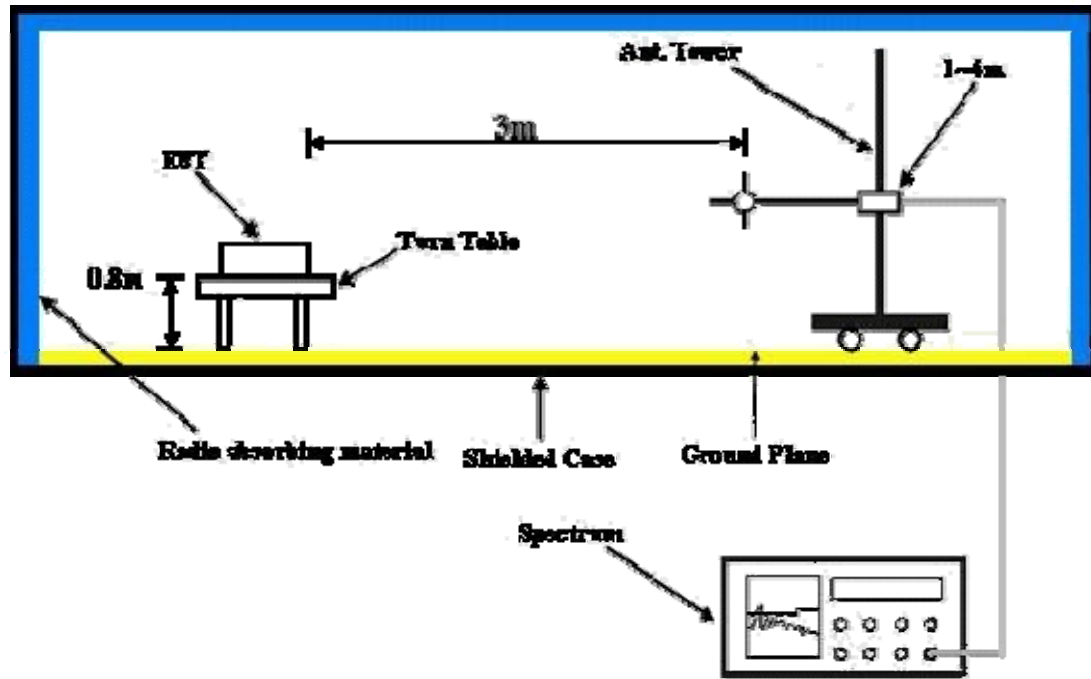

For the actual test configuration, please refer to the attached file (Test Setup Photo).

4.7.6 EUT OPERATING CONDITIONS

- a. The EUT makes a phone call to the communication simulator.
- b. The communication simulator station system controlled an EUT to export maximum output power under transmission mode and specific channel frequency.



A D T

4.7.7 TEST RESULTS

MODE	Channel 25	FREQUENCY RANGE	Above 1000MHz
INPUT POWER (SYSTEM)	120Vac, 60Hz	ENVIRONMENTAL CONDITIONS	23deg°C, 63%RH, 988hPa
TESTED BY	Dean Wang		

ANTENNA POLARITY & TEST DISTANCE: HORIZONTAL AT 3 M						
NO.	FREQ. (MHz)	EMISSION LEVEL (dBuV)	LIMIT (dBm)	S.G POWER VALUE (dBm)	CORRECTION FACTOR (dB)	POWER VALUE (dBm)
1	3702.5	65.2	-13.0	-39.4	9.9	-29.5
2	5553.8	44.0	-13.0	-60.1	9.7	-50.4
3	7405.0	48.5	-13.0	-53.7	7.9	-45.8

ANTENNA POLARITY & TEST DISTANCE: VERTICAL AT 3 M						
NO.	FREQ. (MHz)	EMISSION LEVEL (dBuV)	LIMIT (dBm)	S.G POWER VALUE (dBm)	CORRECTION FACTOR (dB)	POWER VALUE (dBm)
1	3702.5	68.2	-13.0	-36.3	9.9	-26.4
2	5553.8	63.9	-13.0	-39.9	9.7	-30.2
3	7405.0	47.2	-13.0	-54.9	7.9	-47.0

NOTE: Power Value (dBum) = S.G Power Value (dBm) + Correction Factor (dB).



A D T

MODE	Channel 600	FREQUENCY RANGE	Above 1000MHz
INPUT POWER (SYSTEM)	120Vac, 60Hz	ENVIRONMENTAL CONDITIONS	23deg°C, 63%RH, 988hPa
TESTED BY	Dean Wang		

ANTENNA POLARITY & TEST DISTANCE: HORIZONTAL AT 3 M

NO.	FREQ. (MHz)	EMISSION LEVEL (dBuV)	LIMIT (dBm)	S.G POWER VALUE (dBm)	CORRECTION FACTOR (dB)	POWER VALUE (dBm)
1	3760.0	64.8	-13.0	-39.6	9.9	-29.7
2	5640.0	43.3	-13.0	-61.3	9.6	-51.7
3	7520.0	48.1	-13.0	-54.2	7.8	-46.4

ANTENNA POLARITY & TEST DISTANCE: VERTICAL AT 3 M

NO.	FREQ. (MHz)	EMISSION LEVEL (dBuV)	LIMIT (dBm)	S.G POWER VALUE (dBm)	CORRECTION FACTOR (dB)	POWER VALUE (dBm)
1	3760.0	68.0	-13.0	-36.2	9.9	-26.3
2	5640.0	43.5	-13.0	-60.7	9.6	-51.1
3	7520.0	46.9	-13.0	-55.9	7.8	-48.1

NOTE: Power Value (dBm) = S.G Power Value (dBm) + Correction Factor (dB).



A D T

MODE	Channel 1175	FREQUENCY RANGE	Above 1000MHz
INPUT POWER (SYSTEM)	120Vac, 60Hz	ENVIRONMENTAL CONDITIONS	23deg°C, 63%RH, 988hPa
TESTED BY	Dean Wang		

ANTENNA POLARITY & TEST DISTANCE: HORIZONTAL AT 3 M

NO.	FREQ. (MHz)	EMISSION LEVEL (dBuV)	LIMIT (dBm)	S.G POWER VALUE (dBm)	CORRECTION FACTOR (dB)	POWER VALUE (dBm)
1	3817.5	65.7	-13.0	-38.7	9.9	-28.8
2	5726.3	44.2	-13.0	-59.4	9.6	-49.8
3	7635.0	48.9	-13.0	-53.6	7.8	-45.8

ANTENNA POLARITY & TEST DISTANCE: VERTICAL AT 3 M

NO.	FREQ. (MHz)	EMISSION LEVEL (dBuV)	LIMIT (dBm)	S.G POWER VALUE (dBm)	CORRECTION FACTOR (dB)	POWER VALUE (dBm)
1	3817.5	70.1	-13.0	-34.2	9.9	-24.3
2	5726.3	44.5	-13.0	-59.8	9.6	-50.2
3	7635.0	47.9	-13.0	-54.8	7.8	-47.0

NOTE: Power Value (dBum) = S.G Power Value (dBm) + Correction Factor (dB).



A D T

5 INFORMATION ON THE TESTING LABORATORIES

We, Bureau Veritas Consumer Products Services (H.K.) Ltd., Taoyuan Branch, were founded in 1988 to provide our best service in EMC, Radio, Telecom and Safety consultation. Our laboratories are accredited and approved according to ISO/IEC 17025.

Copies of accreditation certificates of our laboratories obtained from approval agencies can be downloaded from our web site: www.adt.com.tw/index.5/phtml. If you have any comments, please feel free to contact us at the following:

Linko EMC/RF Lab:

Tel: 886-2-26052180

Fax: 886-2-26051924

Hsin Chu EMC/RF Lab:

Tel: 886-3-5935343

Fax: 886-3-5935342

Hwa Ya EMC/RF/Safety/Telecom Lab: Web Site: www.adt.com.tw

Tel: 886-3-3183232

Fax: 886-3-3185050

The address and road map of all our labs can be found in our web site also.



A D T

6 APPENDIX A – MODIFICATIONS RECORDERS FOR ENGINEERING CHANGES TO THE EUT BY THE LAB

No any modifications are made to the EUT by the lab during the test.

---END---