

FCC Test Report

EQUIPMENT : Smart Phone
MODEL NAME : MAPL100
FCC ID : NM8MAPL100
STANDARD : 47 CFR Part 2, 22(H), 24(E), 27(L)
CLASSIFICATION : PCS Licensed Transmitter Held to Ear (PCE)
Tx/Rx FREQUENCY RANGE : GSM850 : 824.2 ~ 848.8 MHz /
869.2 ~ 893.8 MHz
GSM1900 : 1850.2 ~ 1909.8 MHz /
1930.2 ~ 1989.8 MHz
WCDMA Band IV : 1712.4 MHz ~ 1752.6 MHz /
2112.4 MHz ~ 2152.6 MHz
MAX. ERP/EIRP POWER : GSM850 (GSM) : 1.44 W
GSM850 (EDGE) : 0.42 W
GSM1900 (GSM) : 0.88 W
GSM1900 (EDGE) : 0.37 W
WCDMA Band IV (WCDMA) : 0.16 W
EMISSION DESIGNATOR : GSM : 246KGXW
EDGE : 248KG7W
WCDMA : 4M18F9W
APPLICANT : HTC Corporation
No. 23, Xinghua Rd., Taoyuan City, Taiwan

The product sample received on Feb. 03, 2009 and completely tested on Mar. 07, 2009. We, SPORTON INTERNATIONAL INC., would like to declare that the tested sample has been evaluated in accordance with the procedures given in ANSI C63.4-2003 and shown compliance with the applicable technical standards.

The test results in this report apply exclusively to the tested model / sample. Without written approval of SPORTON INTERNATIONAL INC., the test report shall not be reproduced except in full.

Reviewed by:



Roy Wu / Manager



SPORTON INTERNATIONAL INC.

No. 52, Hwa Ya 1st Rd., Hwa Ya Technology Park, Kwei-Shan Hsiang, Tao Yuan Hsien, Taiwan, R.O.C.



TABLE OF CONTENTS

REVISION HISTORY..... 3

SUMMARY OF TEST RESULT 4

1 GENERAL DESCRIPTION 5

 1.1 Applicant..... 5

 1.2 Manufacturer 5

 1.3 Feature of Equipment Under Test..... 6

 1.4 Testing Site 7

 1.5 Applied Standards 7

 1.6 Ancillary Equipment List..... 7

2 TEST CONFIGURATION OF EQUIPMENT UNDER TEST 8

 2.1 Test Mode..... 8

 2.2 Connection Diagram of Test System 10

3 TEST RESULT..... 11

 3.1 Conducted Output Power Measurement..... 11

 3.2 Effective Radiated Power and Effective Isotropic Radiated Power Measurement 14

 3.3 Occupied Bandwidth and Band Edge Measurement 18

 3.4 Conducted Emission Measurement 29

 3.5 Field Strength of Spurious Radiation Measurement 43

 3.6 Frequency Stability Measurement..... 65

4 LIST OF MEASURING EQUIPMENT 69

5 UNCERTAINTY OF EVALUATION 70

6 CERTIFICATION OF TAF ACCREDITATION 71

APPENDIX A. PHOTOGRAPHS OF EUT

APPENDIX B. SETUP PHOTOGRAPHS



REVISION HISTORY

REPORT NO.	VERSION	DESCRIPTION	ISSUED DATE
FG920318	Rev. 01	Initial issue of report	Apr. 03, 2009



SUMMARY OF TEST RESULT

Report Section	FCC Rule	IC Rule	Description	Limit	Result
3.1	§2.1046	N/A	Conducted Output Power	N/A	PASS
3.2	§22.913(a)(2)	RSS-132(4.4) SRSP-503(5.1.3)	Effective Radiated Power	< 7 Watts for FCC (<6.3 Watts for IC)	PASS
3.2	§24.232(c)	RSS-133 (6.4) SRSP-510(5.1.2)	Equivalent Isotropic Radiated Power	< 2 Watts	PASS
3.2	§27.50(d)(2)	RSS-139 (6.4) SRSP-513(5.1.2)	Equivalent Isotropic Radiated Power	< 1 Watts	PASS
3.3	§2.1049 §22.917(a) §24.238(a) §27.53(g)	N/A	Occupied Bandwidth	N/A	PASS
3.4	§2.1051 §22.917(a) §24.238(a) §27.53(g)	RSS-132 (4.5.1) RSS-133 (6.5.1) RSS-139 (6.5)	Band Edge Measurement	< 43+10log ₁₀ (P[Watts])	PASS
3.5	§2.1051 §22.917(a) §24.238(a) §27.53(g)	RSS-132 (4.5.1) RSS-133 (6.5.1) RSS-139 (6.5)	Conducted Emission	< 43+10log ₁₀ (P[Watts])	PASS
3.6	§2.1053 §22.917(a) §24.238(a) §27.53(g)	RSS-132 (4.5.1) RSS-133 (6.5.1) RSS-139 (6.5)	Field Strength of Spurious Radiation	< 43+10log ₁₀ (P[Watts])	PASS
3.7	§2.1055 §22.355 §24.235 §27.54	RSS-132(4.3) RSS-133(6.3) RSS-139 (6.3)	Frequency Stability for Temperature & Voltage	< 2.5 ppm	PASS



1 General Description

1.1 Applicant

HTC Corporation

No. 23, Xinghua Rd., Taoyuan City, Taiwan

1.2 Manufacturer

HTC Corporation

No. 23, Xinghua Rd., Taoyuan City, Taiwan



1.3 Feature of Equipment Under Test

Product Feature & Specification	
Equipment	Smart Phone
PDA Phone 1	EUT with LCM 1
PDA Phone 2	EUT with LCM 2
Model Name	MAPL100
FCC ID	NM8MAPL100
Tx Frequency	GSM850 : 824 MHz ~ 849 MHz GSM1900 : 1850 MHz ~ 1910 MHz WCDMA Band IV : 1710 MHz ~ 1755 MHz
Rx Frequency	GSM850 : 869 MHz ~ 894 MHz GSM1900 : 1930 MHz ~ 1990 MHz WCDMA Band IV : 2110 MHz ~ 2155 MHz
Maximum Output Power to Antenna	GSM850 : 31.79 dBm GSM1900 : 28.92 dBm WCDMA Band IV : 22.91 dBm
Maximum ERP/EIRP	GSM850 (GSM) : 1.44 W (31.57 dBm) GSM850 (EDGE 8) : 0.42 W (26.21 dBm) GSM1900 (GSM) : 0.88 W (29.43 dBm) GSM1900 (EDGE 8) : 0.37 W (25.66 dBm) WCDMA Band IV (WCDMA) : 0.16 W (21.91 dBm)
Antenna Type	Fixed Internal Antenna
Type of Modulation	GSM / GPRS : GMSK EDGE : 8PSK WCDMA : QPSK HSDPA : QPSK / 16QAM HSUPA : BPSK
Type of Emission	GSM : 246KGXW EDGE : 248KG7W WCDMA : 4M18F9W
EUT Stage	Production Unit

1.4 Testing Site

Test Site	SPORTON INTERNATIONAL INC.		
Test Site Location	No. 52, Hwa Ya 1 st Rd., Hwa Ya Technology Park, Kwei-Shan Hsiang, Tao Yuan Hsien, Taiwan, R.O.C. TEL: +886-3-327-3456 FAX: +886-3-328-4978		
Test Site No.	Sporton Site No.		FCC/IC Registration No.
	TH02-HY	03CH07-HY	TW1022/4086B-1

1.5 Applied Standards

According to the specifications of the manufacturer, the EUT must comply with the requirements of the following standards:

- ♦ Preliminary Guidance for Receiving Applications for Certification of 3G Device. May 9, 2006.
- ♦ 47 CFR Part 2, 22(H), 24(E), 27(L)
- ♦ ANSI C63.4-2003
- ♦ ANSI / TIA / EIA-603-C-2004
- ♦ IC RSS-132 Issue 2
- ♦ IC RSS-133 Issue 5
- ♦ IC RSS-139 Issue 2

Remark:

1. All test items were verified and recorded according to the standards and without any deviation during the test.
2. This EUT has also been tested and complied with the requirements of FCC Part 15, Subpart B (DoC), recorded in a separate test report.

1.6 Ancillary Equipment List

Item	Equipment	Trade Name	Model No.	FCC ID	Data Cable	Power Cord
1.	System Simulator	R&S	CMU200	N/A	N/A	Unshielded, 1.8 m
2.	BT Base Station	Anritsu	8852B	N/A	N/A	Unshielded, 1.8 m

2 Test Configuration of Equipment Under Test

2.1 Test Mode

During all testing, EUT is in link mode with base station emulator at maximum power level. The spurious emission measurements were carried out in semi-anechoic chamber with 3-meter test range, and EUT is rotated on three test planes to find out the worst emission.

Frequency range investigated for radiated emission is as follows:

1. 30 MHz to 9000 MHz for GSM850
2. 30 MHz to 18000 MHz for WCDMA Band IV.
3. 30 MHz to 19000 MHz for GSM1900.

Test Modes		
Band	Radiated TCs	Conducted TCs
GSM 850	<ul style="list-style-type: none"> ■ GSM Link for PDA Phone 1 ■ EDGE Link for PDA Phone 1 ■ GSM Link for PDA Phone 2 ■ GSM Link + WLAN Link for PDA Phone 1 ■ GSM Link + BT Link for PDA Phone 1 	<ul style="list-style-type: none"> ■ GSM Link for PDA Phone 1 ■ GPRS Link for PDA Phone 1 ■ EDGE Link for PDA Phone 1
GSM 1900	<ul style="list-style-type: none"> ■ GSM Link for PDA Phone 1 ■ EDGE Link for PDA Phone 1 ■ GSM Link for PDA Phone 2 	<ul style="list-style-type: none"> ■ GSM Link for PDA Phone 1 ■ GPRS Link for PDA Phone 1 ■ EDGE Link for PDA Phone 1
WCDMA Band IV	<ul style="list-style-type: none"> ■ WCDMA Link for PDA Phone 1 ■ WCDMA Link for PDA Phone 2 	<ul style="list-style-type: none"> ■ WCDMA Link for PDA Phone 1 ■ HSDPA Link for PDA Phone 1 ■ HSUPA Link for PDA Phone 1

Note: 1. Based on Part 15B report, the worst configuration is Battery 2 and USB Cable 2, which were used for ERP/EIRP and RSE test.

2. The maximum power levels are GSM mode, EDGE multi-slot class 8 mode and WCDMA (RMC 12.2K) mode, only these modes were used for all testing. The conducted power lists are as follow:



Mode	GSM 850			GSM 1900		
	128	189	251	512	661	810
GSM	31.76	31.79	31.78	28.92	28.79	28.83
GPRS 8	31.76	31.79	31.78	28.81	28.78	28.81
GPRS 10	31.72	31.74	31.79	28.87	28.75	28.78
EGPRS 8	26.44	26.41	26.38	25.06	24.92	24.95
EGPRS 10	26.34	26.36	26.35	25.04	24.88	24.91

Mode	WCDMA Band IV			
	1312	1413	1513	
RMC 12.2K	22.68	22.77	22.91	
HSDPA	Subtest-1	22.61	22.68	22.85
	Subtest-2	22.60	22.64	22.70
	Subtest-3	22.23	22.21	22.30
	Subtest-4	22.22	22.24	22.32
HSUPA	Subtest-1	22.59	22.65	22.84
	Subtest-2	21.05	21.11	21.33
	Subtest-3	21.34	21.55	21.49
	Subtest-4	21.06	21.12	21.35
	Subtest-5	22.56	22.67	22.86

2.2 Connection Diagram of Test System

<GSM Link Mode>

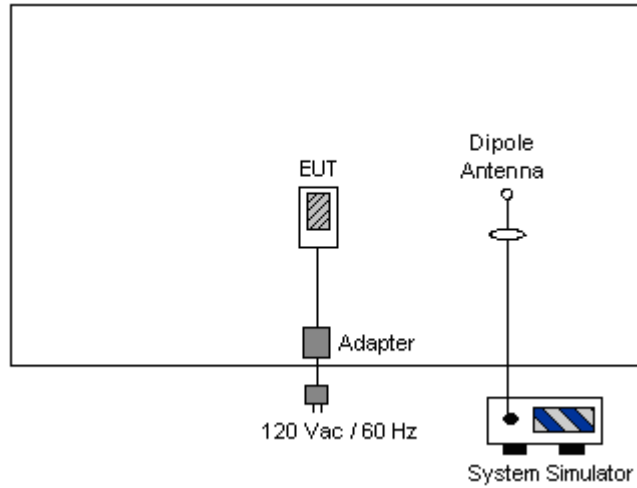

<GSM Link + BT Tx Mode>

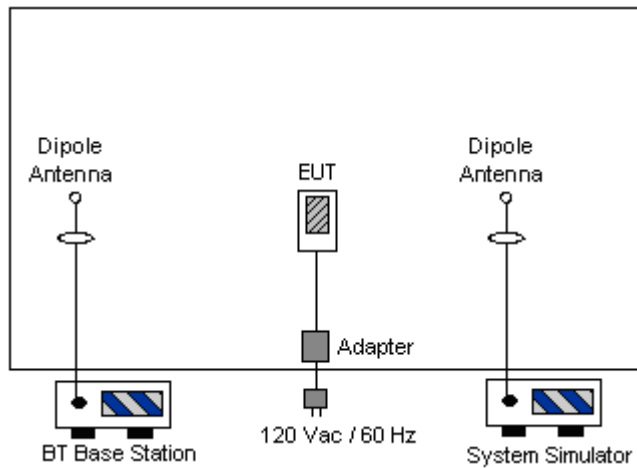

<GSM Link + WLAN Tx Mode>

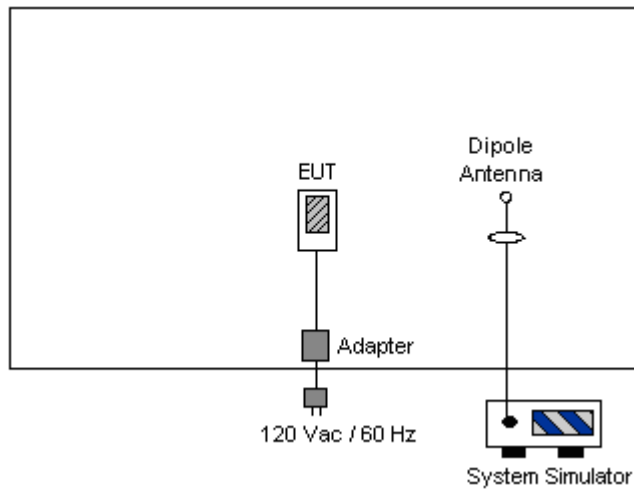

3 Test Result

3.1 Conducted Output Power Measurement

3.1.1 Description of the Conducted Output Power Measurement

A base station simulator was used to establish communication with the EUT. Its parameters were set to transmit the maximum power on the EUT. The measured power in the radio frequency on the transmitter output terminals shall be reported.

3.1.2 Measuring Instruments

See list of measuring instruments of this test report.

3.1.3 Test Procedures

1. The transmitter output port was connected to base station.
2. Set EUT at maximum power through base station.
3. Select lowest, middle, and highest channels for each band and different modulation.

3.1.4 Test Setup

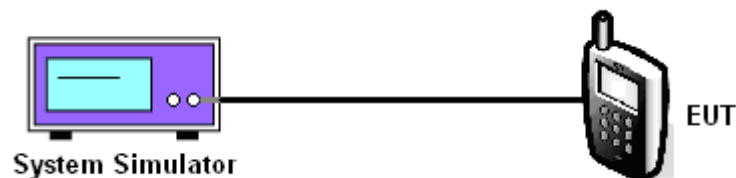



3.1.5 Test Result of Conducted Output Power

Cellular Band				
Modes	Channel	Frequency (MHz)	Conducted Power	
			(dBm)	(Watts)
GSM	128 (Low)	824.2	31.76	1.50
	189 (Mid)	836.4	31.79	1.51
	251 (High)	848.8	31.78	1.51
EDGE 8	128 (Low)	824.2	26.44	0.44
	189 (Mid)	836.4	26.41	0.44
	251 (High)	848.8	26.38	0.43

AWS Band					
Modes	Channel	Frequency (MHz)	Conducted Power		
			(dBm)	(Watts)	
WCDMA Band IV	RMC 12.2k bps	1312 (Low)	1712.4	22.68	0.19
		1413 (Mid)	1732.6	22.77	0.19
		1513 (High)	1752.6	22.91	0.20
	HSDPA Subtest-1	1312 (Low)	1712.4	22.61	0.18
		1413 (Mid)	1732.6	22.68	0.19
		1513 (High)	1752.6	22.85	0.19
	HSDPA Subtest-2	1312 (Low)	1712.4	22.60	0.18
		1413 (Mid)	1732.6	22.64	0.18
		1513 (High)	1752.6	22.70	0.19
	HSDPA Subtest-3	1312 (Low)	1712.4	22.23	0.17
		1413 (Mid)	1732.6	22.21	0.17
		1513 (High)	1752.6	22.30	0.17
	HSDPA Subtest-4	1312 (Low)	1712.4	22.22	0.17
		1413 (Mid)	1732.6	22.24	0.17
		1513 (High)	1752.6	22.32	0.17
	HSUPA Subtest-1	1312 (Low)	1712.4	22.59	0.18
		1413 (Mid)	1732.6	22.65	0.18
		1513 (High)	1752.6	22.84	0.19
	HSUPA Subtest-2	1312 (Low)	1712.4	21.05	0.13
		1413 (Mid)	1732.6	21.11	0.13
		1513 (High)	1752.6	21.33	0.14
	HSUPA Subtest-3	1312 (Low)	1712.4	21.34	0.14
		1413 (Mid)	1732.6	21.55	0.14
		1513 (High)	1752.6	21.49	0.14
HSUPA Subtest-4	1312 (Low)	1712.4	21.06	0.13	
	1413 (Mid)	1732.6	21.12	0.13	
	1513 (High)	1752.6	21.35	0.14	
HSUPA Subtest-5	1312 (Low)	1712.4	22.56	0.18	
	1413 (Mid)	1732.6	22.67	0.18	
	1513 (High)	1752.6	22.86	0.19	



PCS Band				
Modes	Channel	Frequency (MHz)	Conducted Power	
			(dBm)	(Watts)
GSM	512 (Low)	1850.2	28.92	0.78
	661 (Mid)	1880.0	28.79	0.76
	810 (High)	1909.8	28.83	0.76
EDGE 8	512 (Low)	1850.2	25.06	0.32
	661 (Mid)	1880.0	24.92	0.31
	810 (High)	1909.8	24.95	0.31

3.2 Effective Radiated Power and Effective Isotropic Radiated Power Measurement

3.2.1 Description of the ERP/EIRP Measurement

ERP/EIRP is measured by substitution method according to ANSI / TIA / EIA-603-C-2004. The ERP of mobile transmitters must not exceed 7 Watts, operating in the 1710-1755 MHz band are limited to a peak EIRP of 1 watt, and the EIRP of mobile transmitters are limited to 2 Watts.

3.2.2 Measuring Instruments

See list of measuring instruments of this test report.

3.2.3 Test Procedures

1. The EUT was placed on a turntable with 1.0 meter height in a fully anechoic chamber.
2. The EUT was set at 1.2 meters from the receiving antenna, which was mounted on the antenna tower.
3. The table was rotated 360 degrees to determine the position of the highest radiated power.
4. The height of the receiving antenna is adjusted to look for the maximum ERP/EIRP.
5. Taking the record of maximum ERP/EIRP.
6. A dipole antenna was substituted in place of the EUT and was driven by a signal generator.
7. The conducted power at the terminal of the dipole antenna is measured.
8. Repeat step 3 to step 5 to get the maximum ERP/EIRP of the substitution antenna.
9. $ERP/EIRP = P_s + E_t - E_s + G_s = P_s + R_t - R_s + G_s$

P_s (dBm) : Input power to substitution antenna.

G_s (dBi or dBd) : Substitution antenna Gain.

$E_t = R_t + AF$

$E_s = R_s + AF$

AF (dB/m) : Receive antenna factor

R_t : The highest received signal in spectrum analyzer for EUT.

R_s : The highest received signal in spectrum analyzer for substitution antenna.

3.2.4 Test Setup

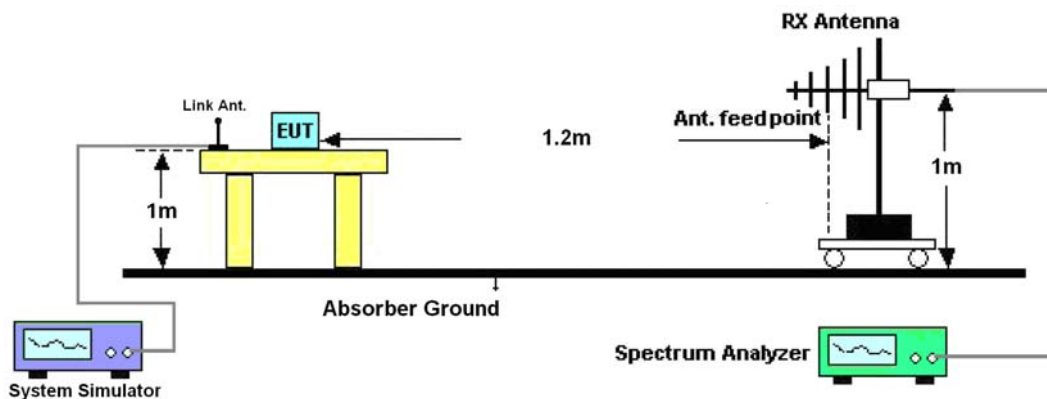



3.2.5 Test Result of ERP

GSM850 (GSM) Radiated Power ERP_PDA Phone 1						
Horizontal Polarization						
Frequency (MHz)	Rt (dBm)	Rs (dBm)	Ps (dBm)	Gs (dBd)	ERP (dBm)	ERP (W)
824.20	-33.28	-48.12	0.00	-1.08	13.76	0.02
836.40	-33.09	-48.28	0.00	-0.93	14.26	0.03
848.80	-34.26	-48.35	0.00	-0.76	13.33	0.02
Vertical Polarization						
Frequency (MHz)	Rt (dBm)	Rs (dBm)	Ps (dBm)	Gs (dBd)	ERP (dBm)	ERP (W)
824.20	-15.32	-47.97	0.00	-1.08	31.57	1.44
836.40	-16.51	-48.01	0.00	-0.93	30.57	1.14
848.80	-18.54	-48.05	0.00	-0.76	28.75	0.75

GSM850 (EDGE 8) Radiated Power ERP_PDA Phone 1						
Horizontal Polarization						
Frequency (MHz)	Rt (dBm)	Rs (dBm)	Ps (dBm)	Gs (dBd)	ERP (dBm)	ERP (W)
824.20	-39.93	-48.12	0.00	-1.08	7.11	0.01
836.40	-39.49	-48.28	0.00	-0.93	7.86	0.01
848.80	-40.49	-48.35	0.00	-0.76	7.10	0.01
Vertical Polarization						
Frequency (MHz)	Rt (dBm)	Rs (dBm)	Ps (dBm)	Gs (dBd)	ERP (dBm)	ERP (W)
824.20	-20.68	-47.97	0.00	-1.08	26.21	0.42
836.40	-22.03	-48.01	0.00	-0.93	25.05	0.32
848.80	-24.01	-48.05	0.00	-0.76	23.28	0.21



3.2.6 Test Result of EIRP

GSM1900 (GSM) Radiated Power EIRP_PDA Phone 1						
Horizontal Polarization						
Frequency (MHz)	Rt (dBm)	Rs (dBm)	Ps (dBm)	Gs (dBi)	EIRP (dBm)	EIRP (W)
1850.20	-24.65	-51.88	0.00	1.96	29.19	0.83
1880.00	-25.56	-52.99	0.00	2.00	29.43	0.88
1909.80	-27.96	-54.28	0.00	1.98	28.30	0.68
Vertical Polarization						
Frequency (MHz)	Rt (dBm)	Rs (dBm)	Ps (dBm)	Gs (dBi)	EIRP (dBm)	EIRP (W)
1850.20	-25.04	-52.13	0.00	1.96	29.05	0.80
1880.00	-26.03	-53.17	0.00	2.00	29.14	0.82
1909.80	-28.43	-54.13	0.00	1.98	27.68	0.59

GSM1900 (EDGE 8) Radiated Power EIRP_PDA Phone 1						
Horizontal Polarization						
Frequency (MHz)	Rt (dBm)	Rs (dBm)	Ps (dBm)	Gs (dBi)	EIRP (dBm)	EIRP (W)
1850.20	-28.76	-51.88	0.00	1.96	25.08	0.32
1880.00	-29.33	-52.99	0.00	2.00	25.66	0.37
1909.80	-31.62	-54.28	0.00	1.98	24.64	0.29
Vertical Polarization						
Frequency (MHz)	Rt (dBm)	Rs (dBm)	Ps (dBm)	Gs (dBi)	EIRP (dBm)	EIRP (W)
1850.20	-29.09	-52.13	0.00	1.96	25.00	0.32
1880.00	-29.84	-53.17	0.00	2.00	25.33	0.34
1909.80	-32.11	-54.13	0.00	1.98	24.00	0.25



WCDMA Band IV (WCDMA) Radiated Power EIRP_PDA Phone 1						
Horizontal Polarization						
Frequency (MHz)	Rt (dBm)	Rs (dBm)	Ps (dBm)	Gs (dBi)	EIRP (dBm)	EIRP (W)
1712.4	-32.43	-51.88	0.00	1.96	21.41	0.14
1732.6	-34.03	-52.99	0.00	2.00	20.96	0.12
1752.6	-34.35	-54.28	0.00	1.98	21.91	0.16
Vertical Polarization						
Frequency (MHz)	Rt (dBm)	Rs (dBm)	Ps (dBm)	Gs (dBi)	EIRP (dBm)	EIRP (W)
1712.4	-32.39	-52.13	0.00	1.96	21.70	0.15
1732.6	-34.32	-53.17	0.00	2.00	20.85	0.12
1752.6	-34.58	-54.13	0.00	1.98	21.53	0.14

3.3 Occupied Bandwidth and Band Edge Measurement

3.3.1 Description of Occupied Bandwidth and Band Edge Measurement

The power of any emission outside of the authorized operating frequency ranges must be lower than the transmitter power (P) by a factor of at least $43 + 10 \log (P)$ dB.

The emission bandwidth is defined as the width of the signal between two points, located at the 2 sides of the carrier frequency, outside of which all emissions are attenuated at least 26 dB below the transmitter power.

3.3.2 Measuring Instruments

See list of measuring instruments of this test report.

3.3.3 Test Procedures

1. The EUT was connected to Spectrum Analyzer and Base Station via power divider.
2. The 99% and 26 dB occupied bandwidth (BW) of the middle channel for the highest RF powers were measured.
3. The band edges of low and high channels for the highest RF powers were measured. Setting RBW as roughly BW/100.
4. The RBW was replaced by 10 kHz, due to the spectrum analyzer IF-Filter including an excess of the limit. A worst case correction factor of $10 \log (1\% \text{ BW}/\text{measurement RBW})$ was implemented.

3.3.4 Test Setup

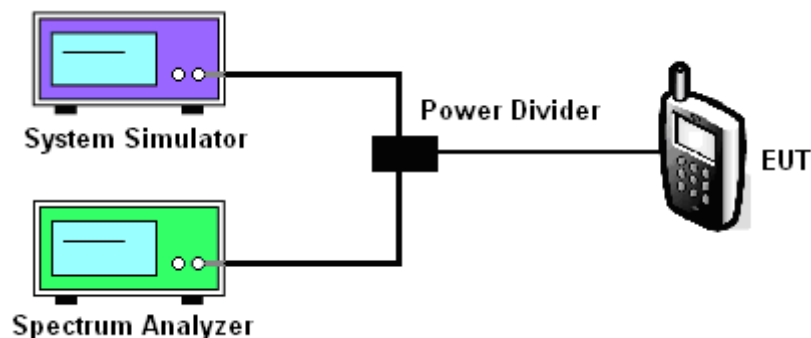



3.3.5 Test Result (Plots) of Occupied Bandwidth

Band :	GSM 850	Power Stage :	High
Test Mode :	GSM Link		

99% Occupied Bandwidth Plot on Channel 189

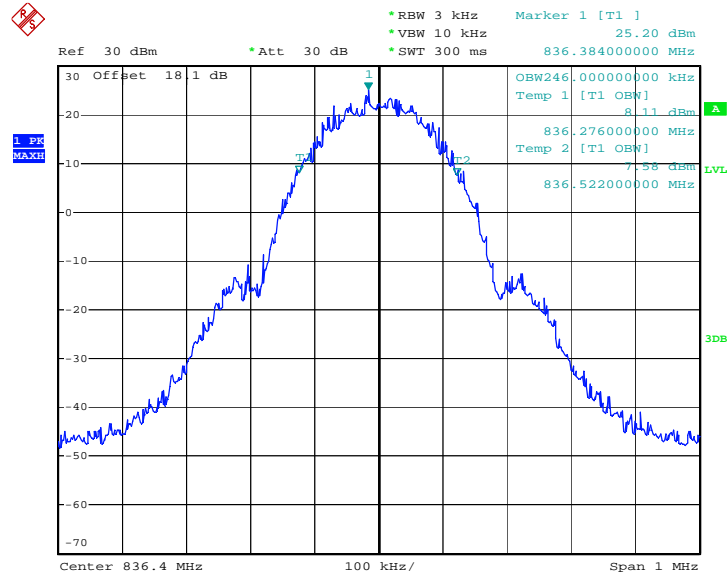

Date: 21.FEB.2009 22:14:19

26dB Bandwidth Plot on Channel 189

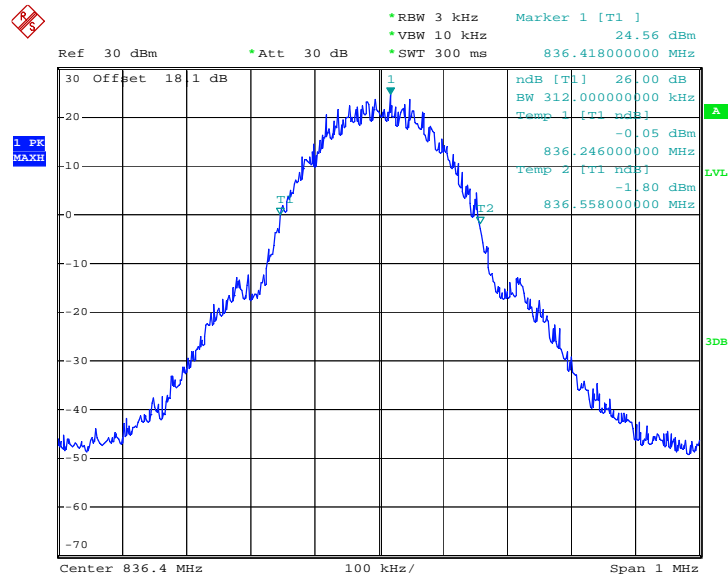

Date: 21.FEB.2009 22:10:36



Band :	GSM 850	Power Stage :	High
Test Mode :	EDGE 8 Link		

99% Occupied Bandwidth Plot on Channel 189

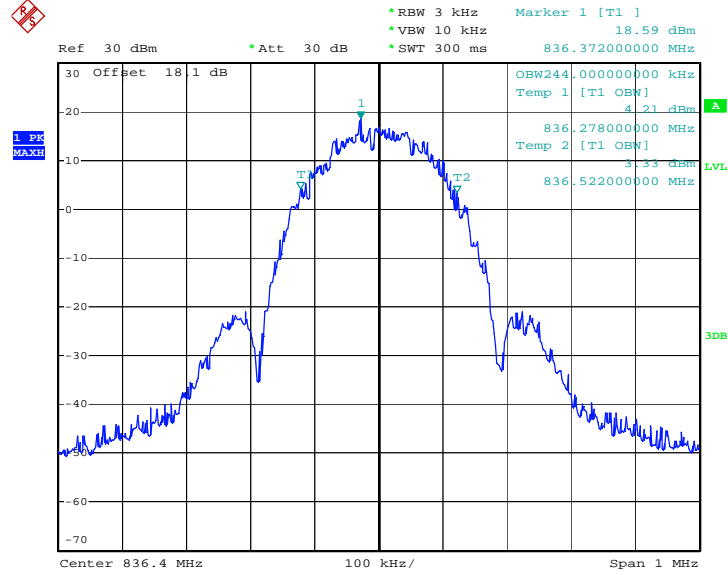

Date: 21.FEB.2009 22:32:56

26dB Bandwidth Plot on Channel 189

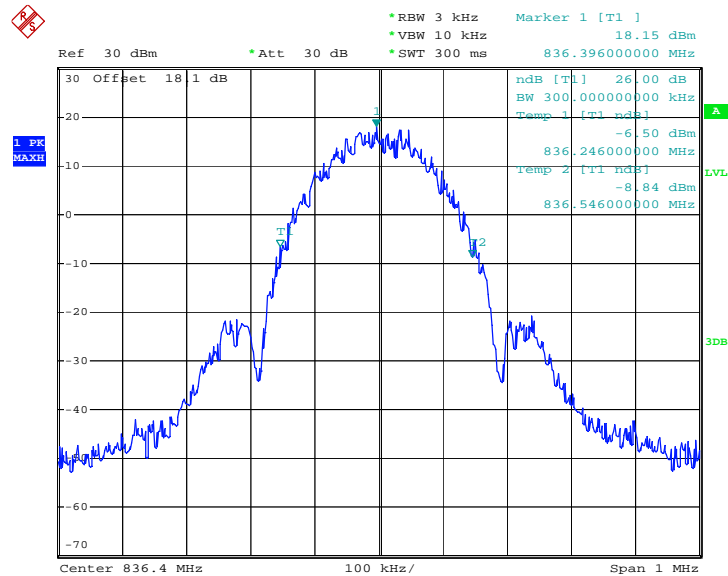

Date: 21.FEB.2009 22:29:42



Band :	GSM 1900	Power Stage :	High
Test Mode :	GSM Link		

99% Occupied Bandwidth Plot on Channel 661

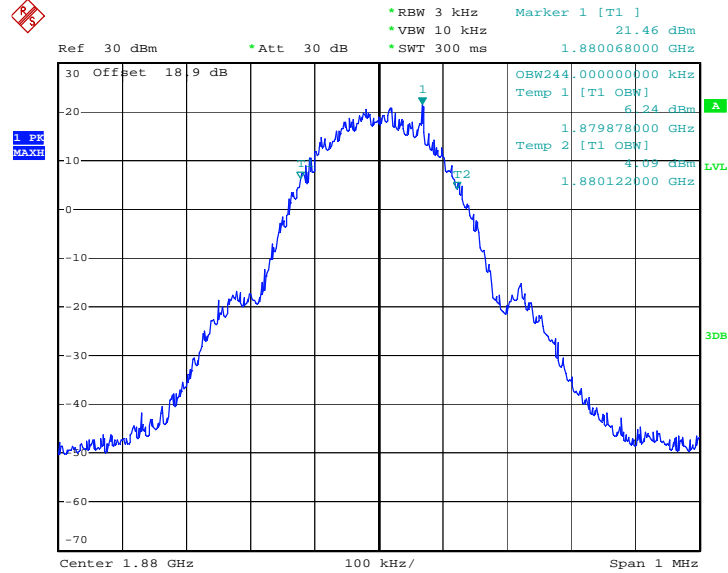

Date: 21.FEB.2009 22:54:30

26dB Bandwidth Plot on Channel 661

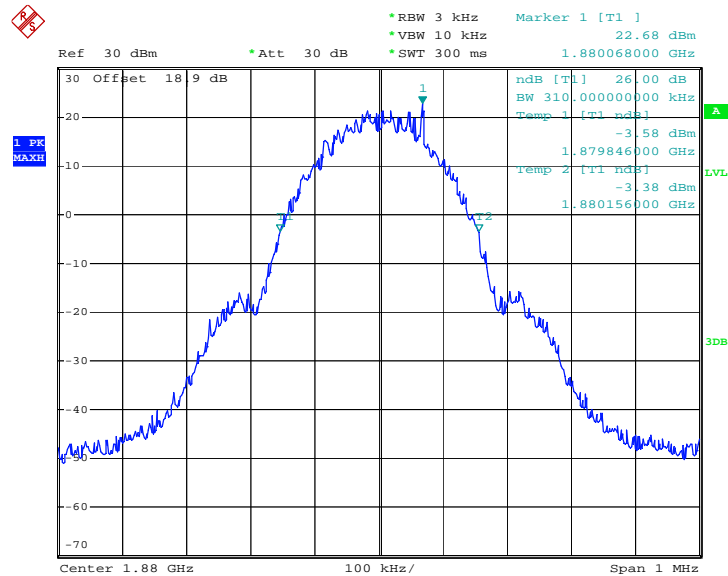

Date: 21.FEB.2009 22:51:45



Band :	GSM 1900	Power Stage :	High
Test Mode :	EDGE 8 Link		

99% Occupied Bandwidth Plot on Channel 661

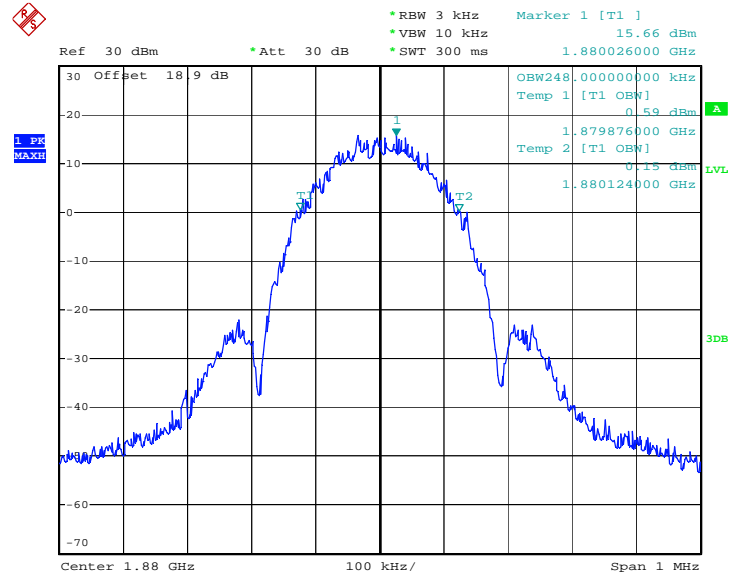

Date: 21.FEB.2009 23:35:34

26dB Bandwidth Plot on Channel 661

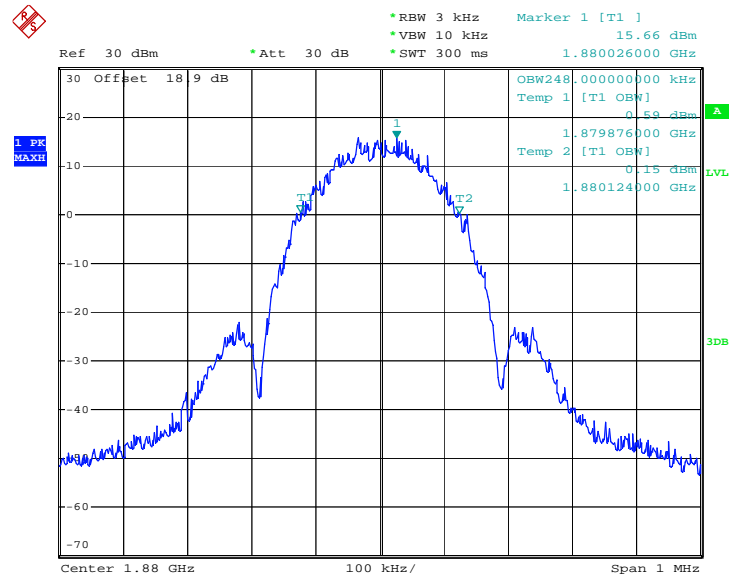

Date: 21.FEB.2009 23:35:34



Band :	WCDMA Band IV	Power Stage :	High
Test Mode :	WCDMA Link		

99% Occupied Bandwidth Plot on Channel 1413

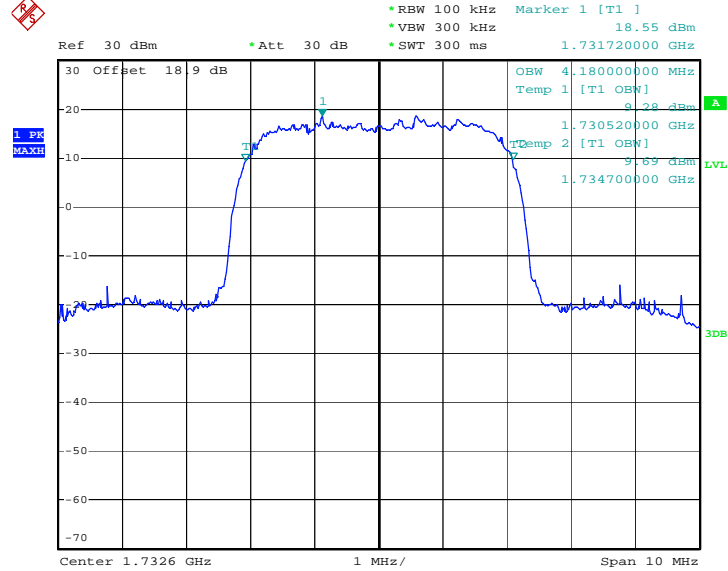

HAC-189-E

Date: 4.MAR.2009 15:27:23

26dB Bandwidth Plot on Channel 1413

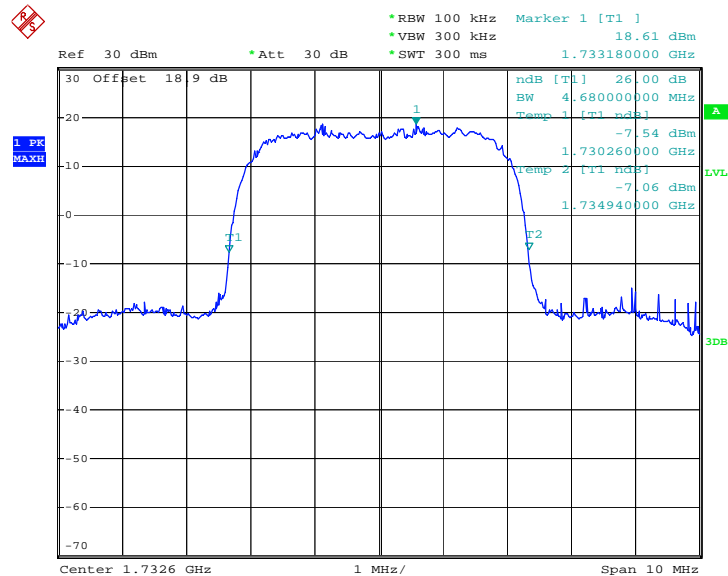

HAC-189-E

Date: 4.MAR.2009 15:25:31



3.3.6 Test Result (Plots) of Conducted Band Edges

Band :	GSM850	Power Stage :	High
Test Mode :	GSM Link		

Lower Band Edge Plot on Channel 128

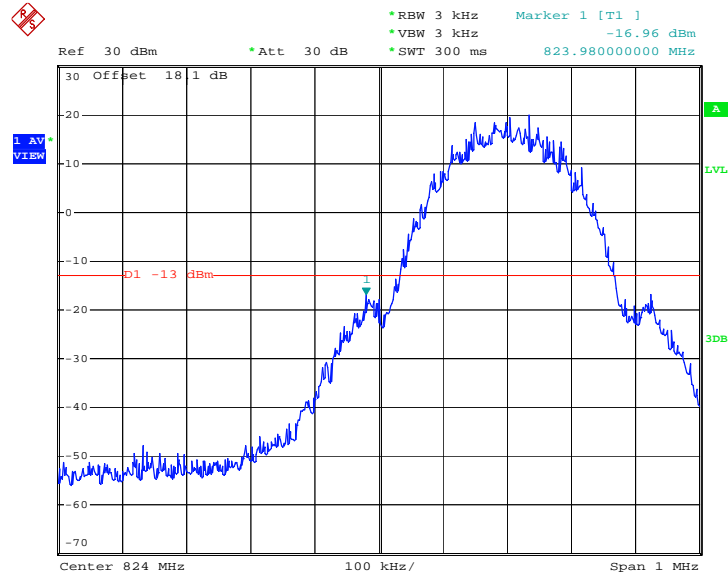

Date: 21.FEB.2009 22:16:12

Higher Band Edge Plot on Channel 251

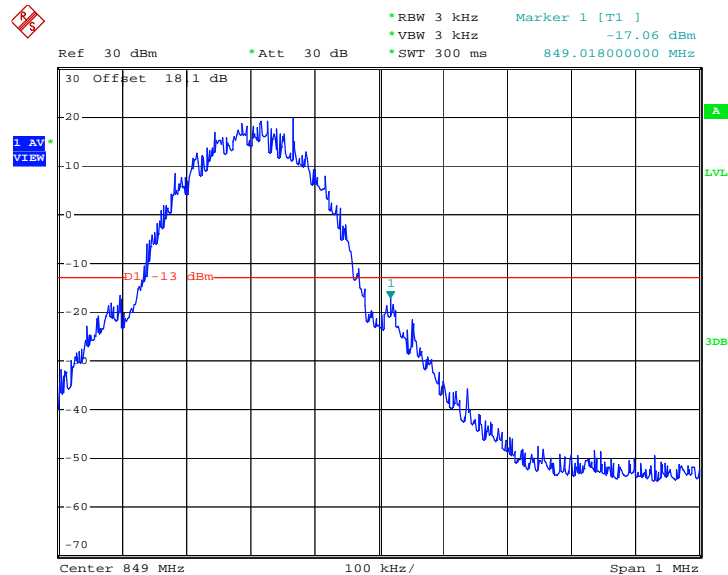

Date: 21.FEB.2009 22:18:30



Band :	GSM850	Power Stage :	High
Test Mode :	EDGE 8 Link		

Lower Band Edge Plot on Channel 128

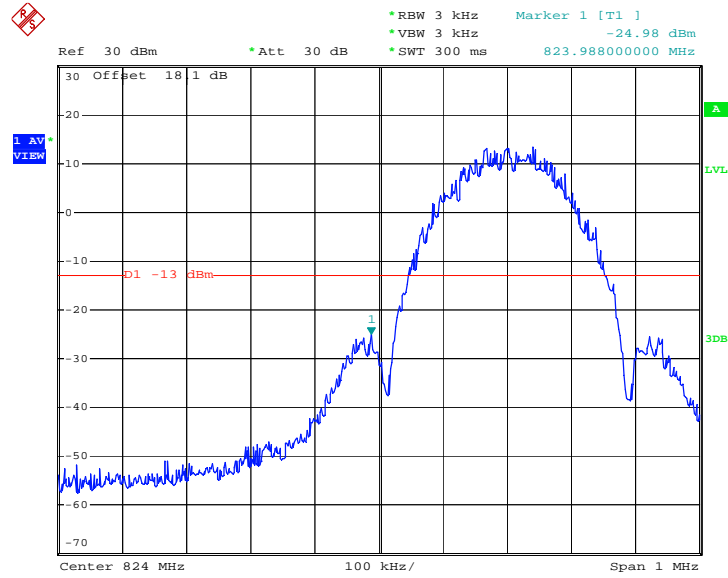

Date: 21.FEB.2009 22:35:46

Higher Band Edge Plot on Channel 251

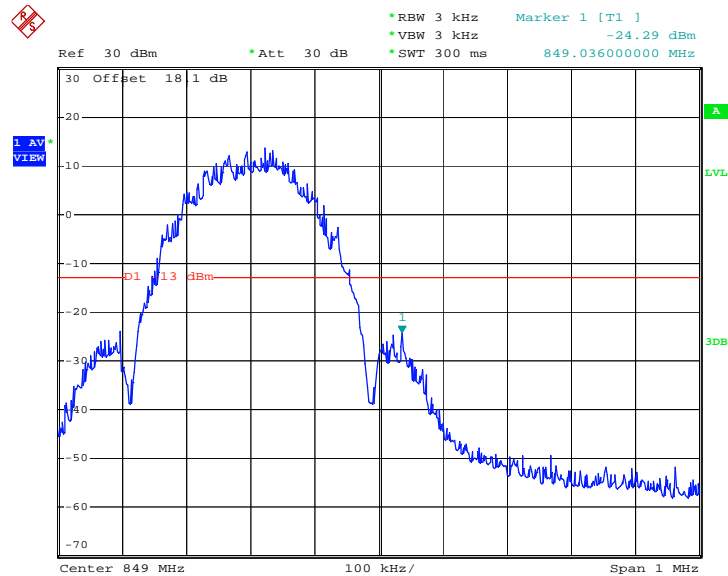

Date: 21.FEB.2009 22:40:31



Band :	GSM1900	Power Stage :	High
Test Mode :	GSM Link		

Lower Band Edge Plot on Channel 512

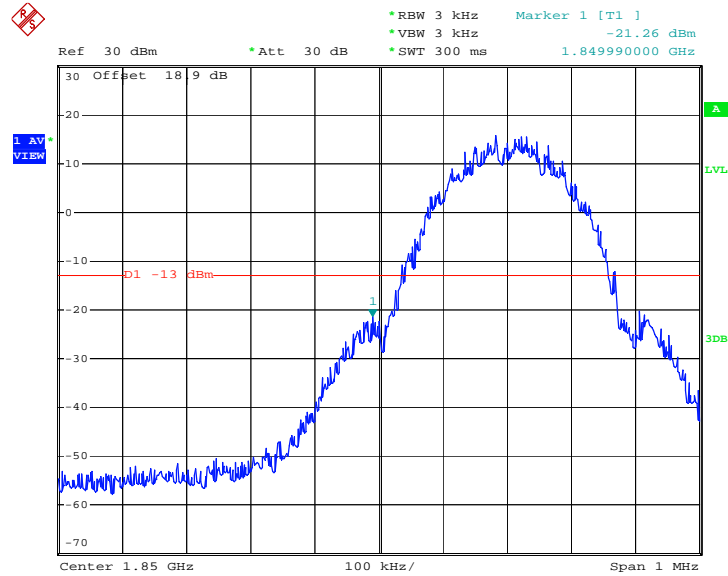

Date: 21.FEB.2009 22:56:39

Higher Band Edge Plot on Channel 810

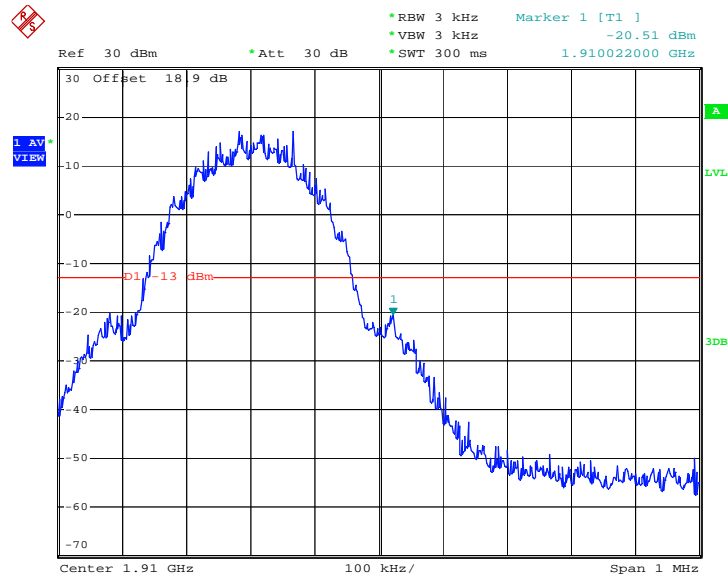

Date: 21.FEB.2009 22:59:47



Band :	GSM1900	Power Stage :	High
Test Mode :	EDGE 8 Link		

Lower Band Edge Plot on Channel 512

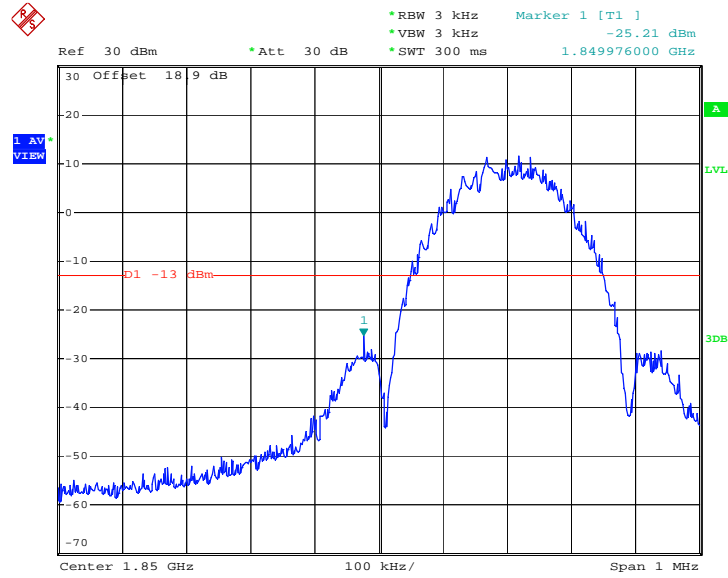

Date: 21.FEB.2009 23:40:19

Higher Band Edge Plot on Channel 810

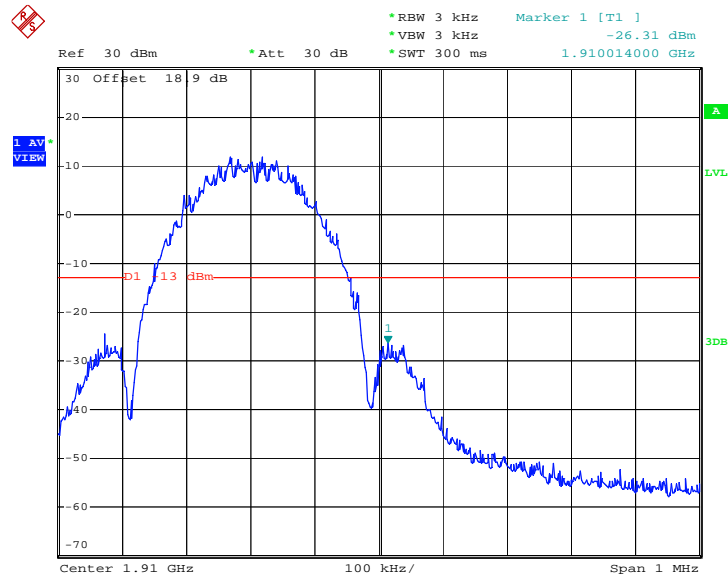

Date: 21.FEB.2009 23:46:01



Band :	WCDMA Band IV	Power Stage :	High
Test Mode :	WCDMA Link		

Lower Band Edge Plot on Channel 1312

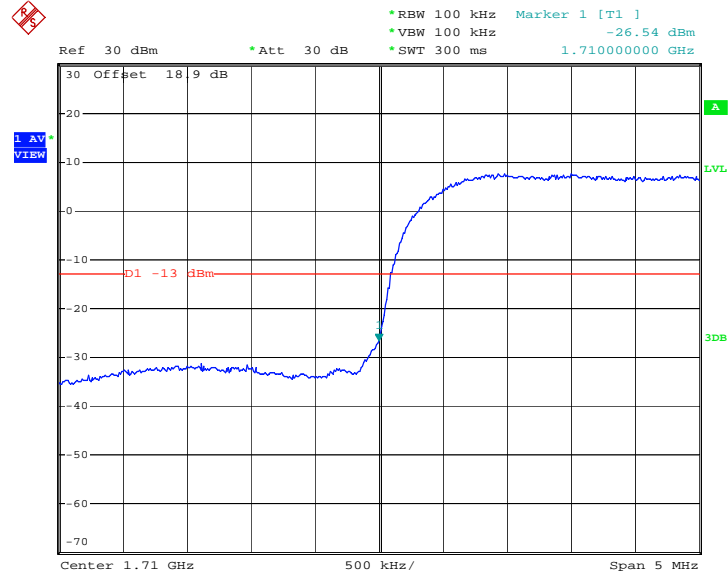

HAC-189-E

Date: 4.MAR.2009 15:23:44

Higher Band Edge Plot on Channel 1513

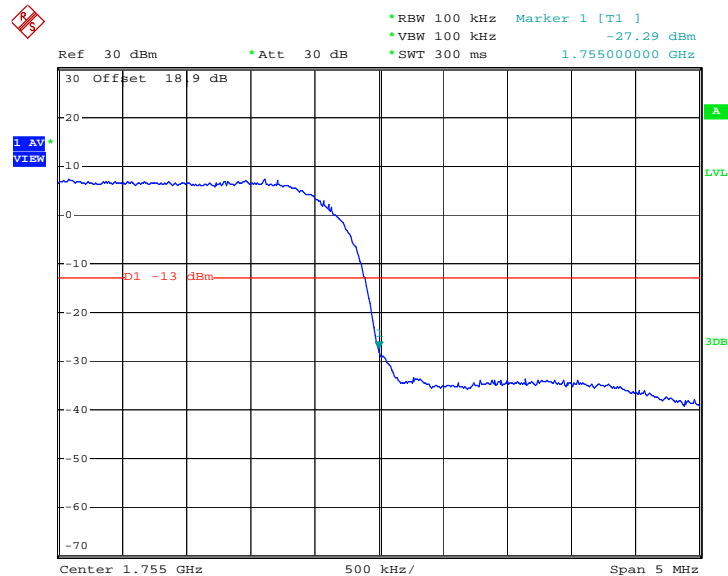

HAC-189-E

Date: 4.MAR.2009 15:22:09

3.4 Conducted Emission Measurement

3.4.1 Description of Conducted Emission Measurement

The power of any emission outside of the authorized operating frequency ranges must be lower than the transmitter power (P) by a factor of at least $43 + 10 \log (P)$ dB.

It is measured by means of a calibrated spectrum analyzer and scanned from 30 MHz up to a frequency including its 10th harmonic.

3.4.2 Measuring Instruments

See list of measuring instruments of this test report.

3.4.3 Test Procedures

1. The EUT was connected to spectrum analyzer and base station via power divider.
2. The middle channel for the highest RF power within the transmitting frequency was measured.
3. The conducted spurious emission for the whole frequency range was taken.

3.4.4 Test Setup

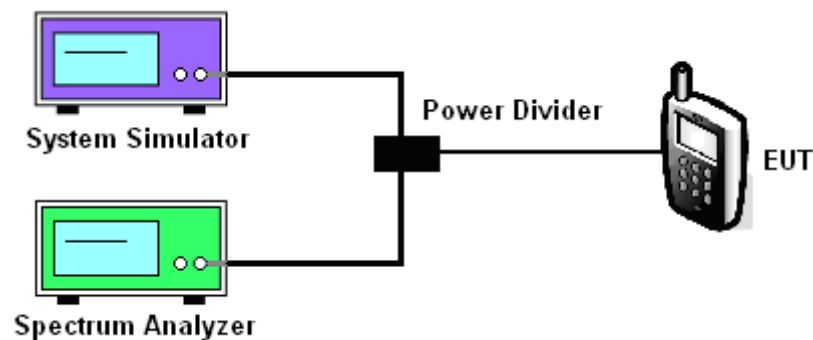



3.4.5 Test Result (Plots) of Conducted Emission

Band :	GSM850	Channel :	CH189
Test Mode :	GSM Link		

Conducted Emission Plot between 30M-1G

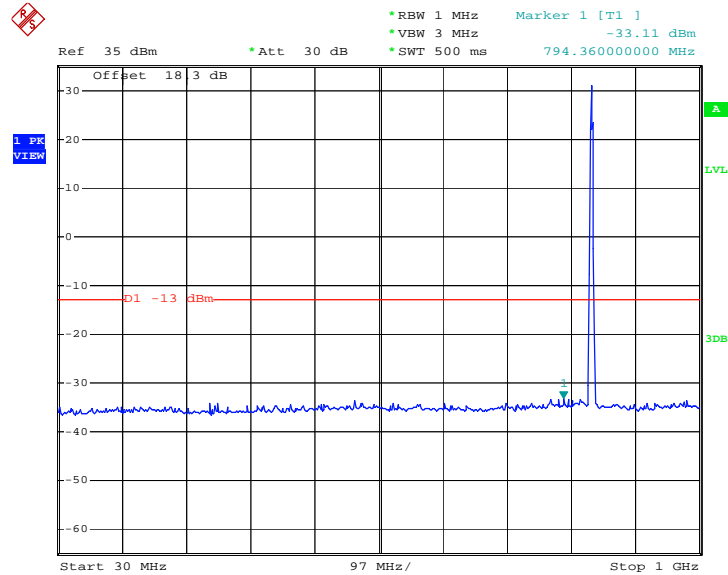

Date: 28.MAR.2009 15:13:19

Conducted Emission Plot between 1GHz ~ 3GHz

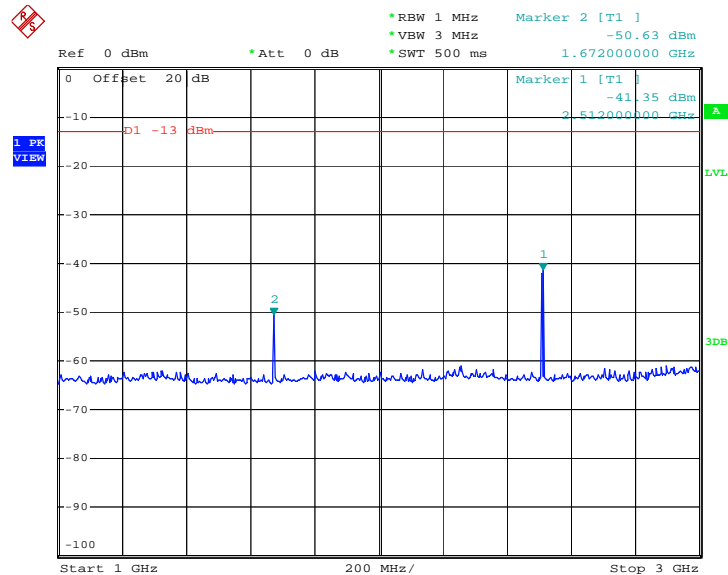

Date: 28.MAR.2009 15:14:14



Conducted Emission Plot between 3GHz ~ 7GHz

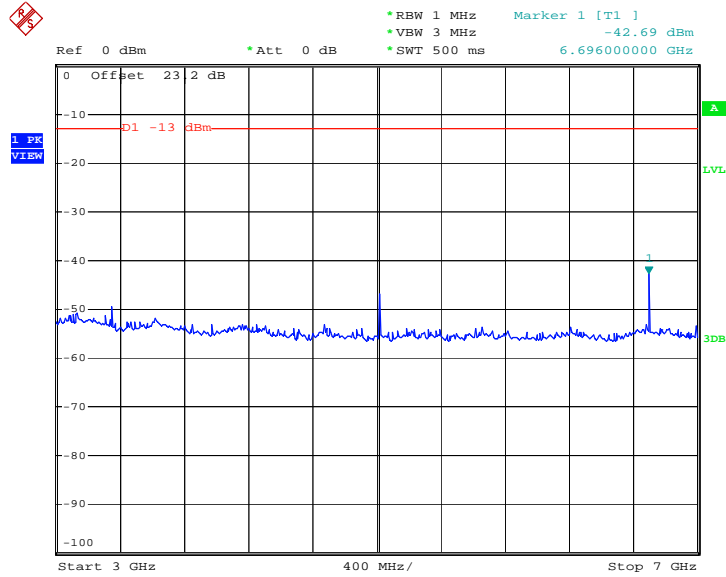

Date: 28.MAR.2009 15:14:40

Conducted Emission Plot between 7GHz ~ 9GHz

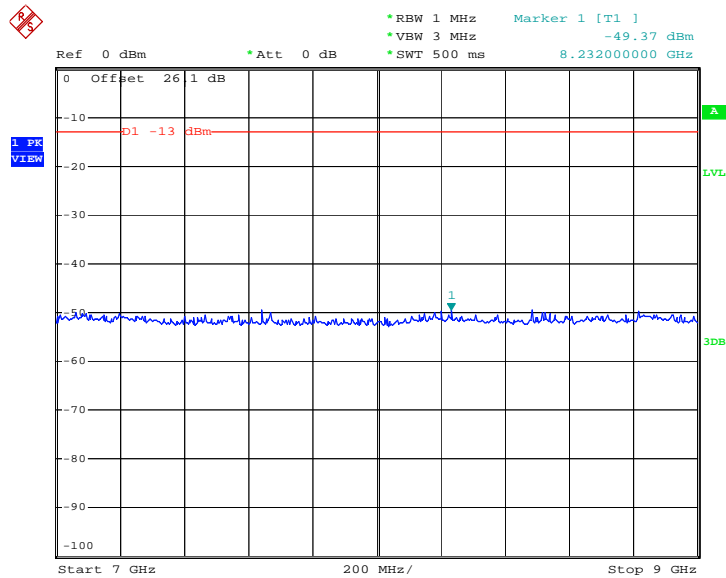

Date: 28.MAR.2009 15:15:12



Band :	GSM850	Channel :	CH189
Test Mode :	EDGE 8 Link		

Conducted Emission Plot between 30M-1G

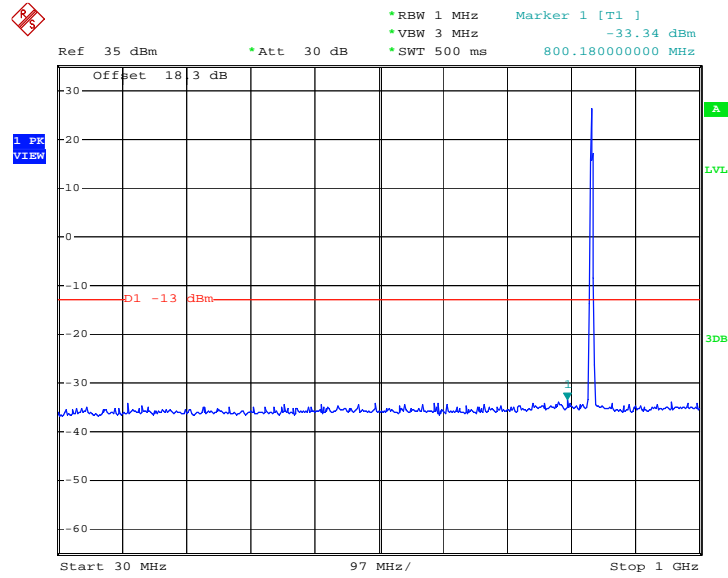

Date: 28.MAR.2009 14:28:01

Conducted Emission Plot between 1GHz ~ 3GHz

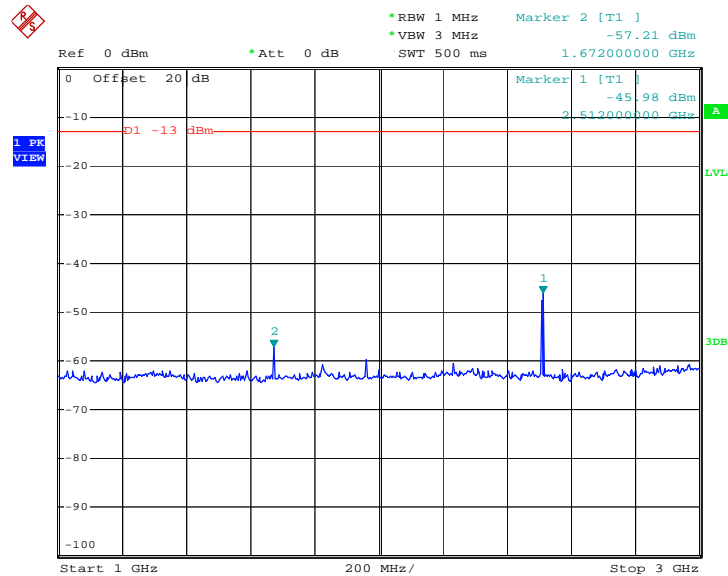

Date: 28.MAR.2009 14:34:38



Conducted Emission Plot between 3GHz ~ 7GHz

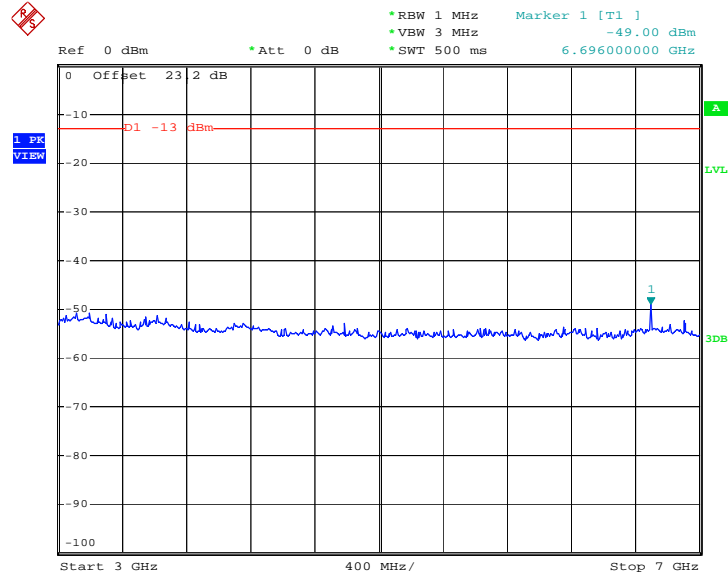

Date: 28.MAR.2009 14:37:20

Conducted Emission Plot between 7GHz ~ 9GHz

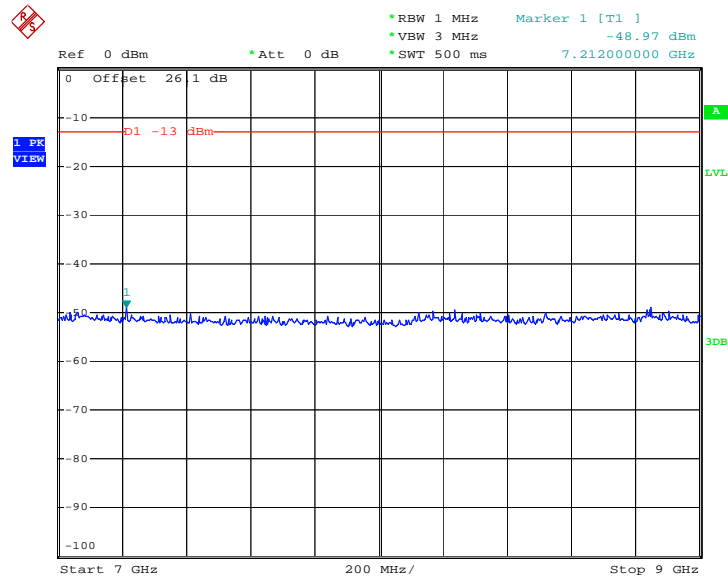

Date: 28.MAR.2009 14:38:41



Band :	GSM1900	Channel :	CH661
Test Mode :	GSM Link		

Conducted Emission Plot between 30M-1G

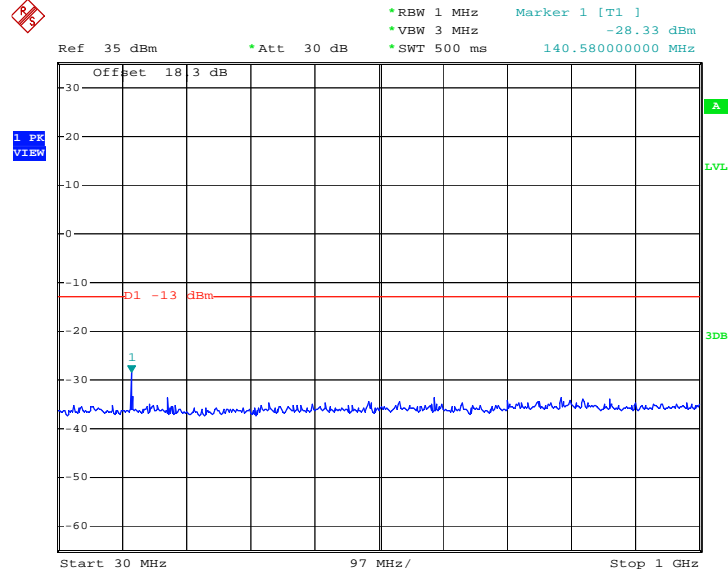

Date: 28.MAR.2009 14:26:46

Conducted Emission Plot between 1GHz ~ 3GHz

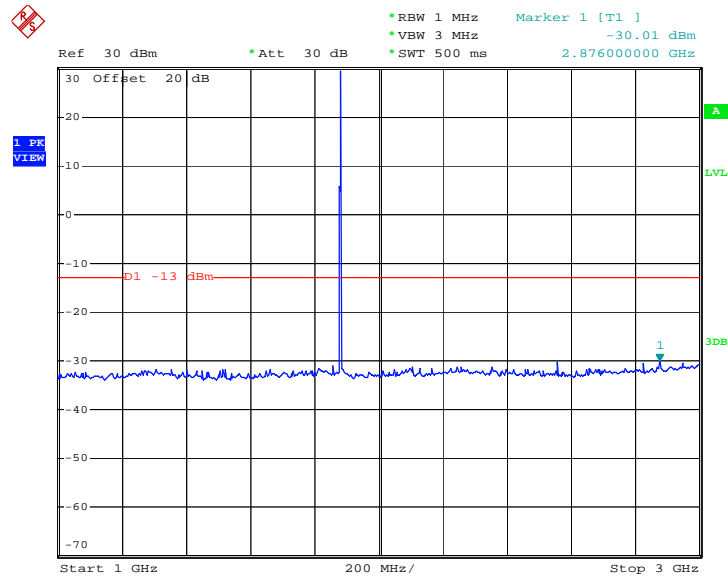

Date: 28.MAR.2009 14:31:41



Conducted Emission Plot between 3G-7G

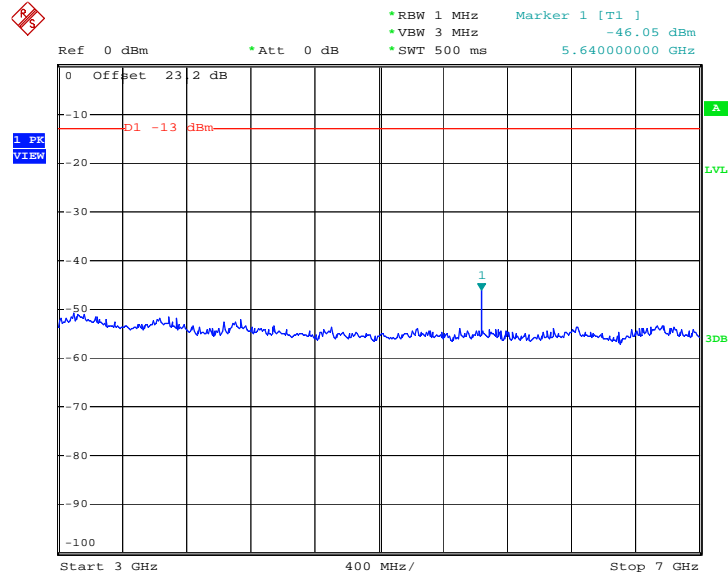

Date: 28.MAR.2009 14:36:36

Conducted Emission Plot between 7G-13.6G

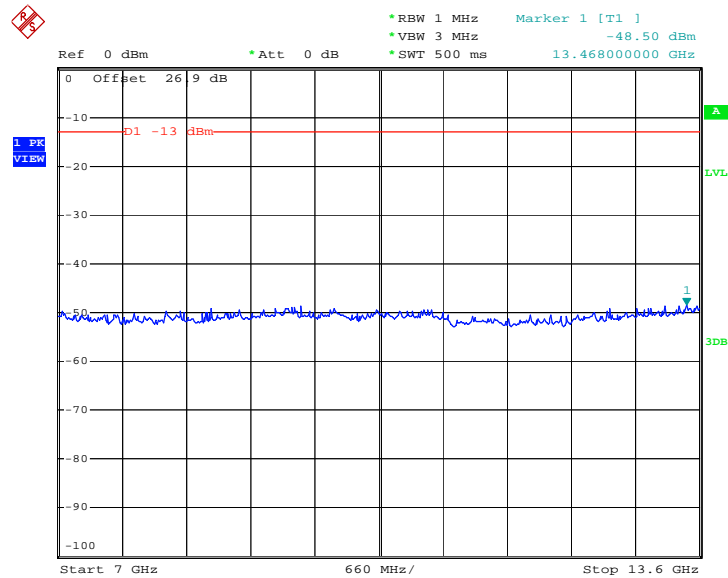

Date: 28.MAR.2009 14:40:42



Conducted Emission Plot between 13.6G-19.1G

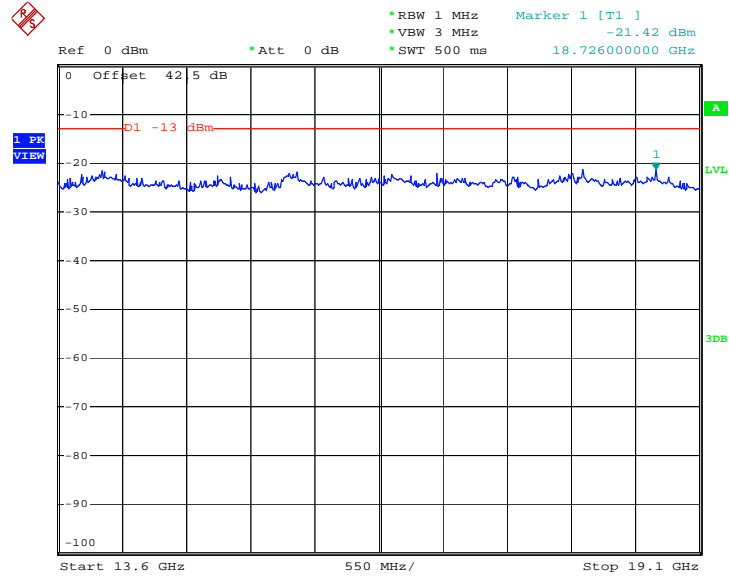

Date: 28.MAR.2009 14:41:11



Band :	GSM1900	Channel :	CH661
Test Mode :	EDGE 8 Link		

Conducted Emission Plot between 30M-1G

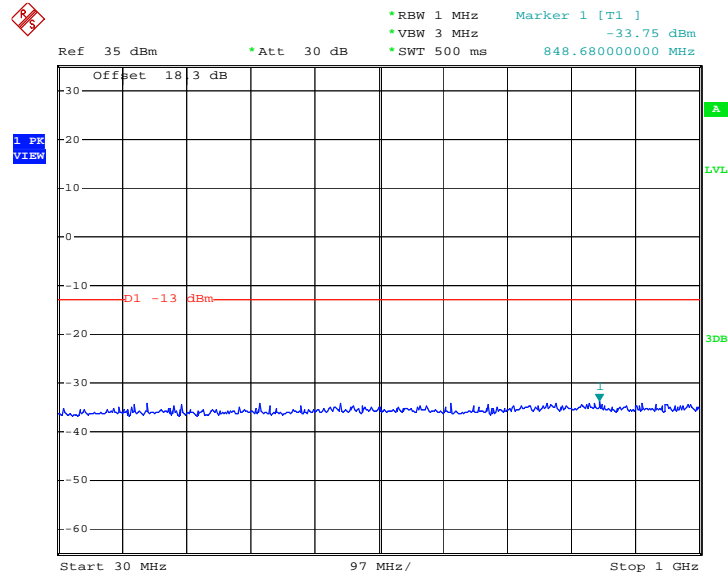

Date: 28.MAR.2009 14:29:00

Conducted Emission Plot between 1GHz ~ 3GHz

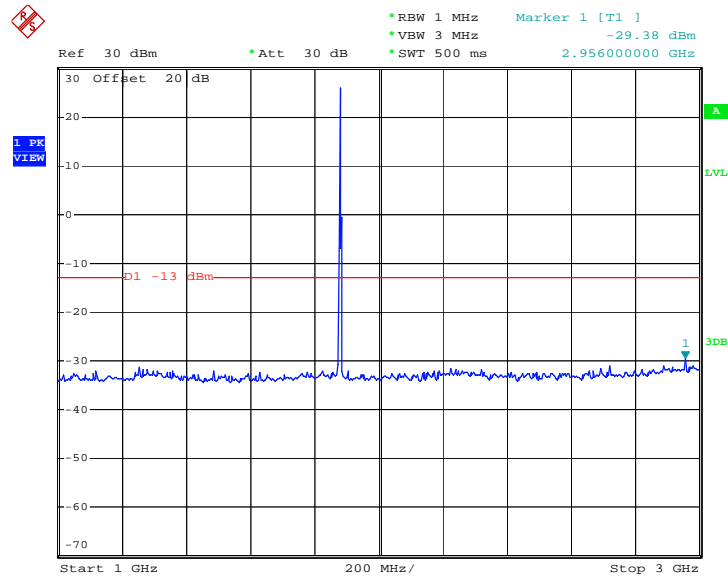

Date: 28.MAR.2009 14:32:35



Conducted Emission Plot between 3G-7G

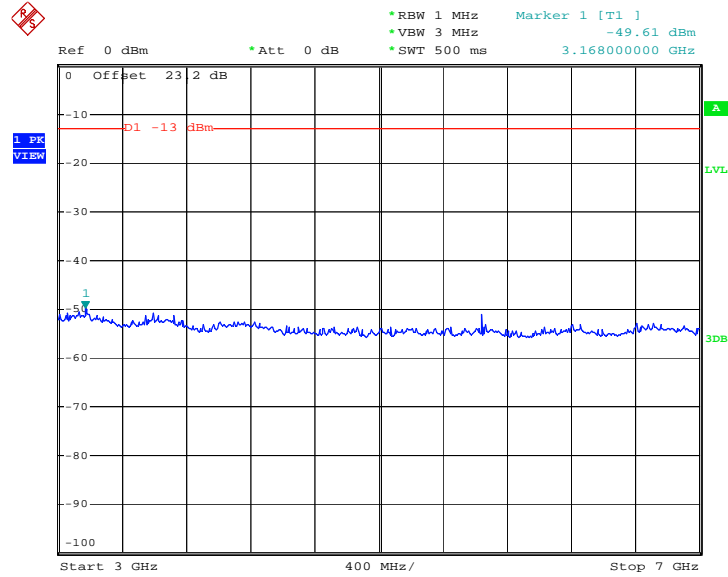

Date: 28.MAR.2009 14:38:02

Conducted Emission Plot between 7G-13.6G

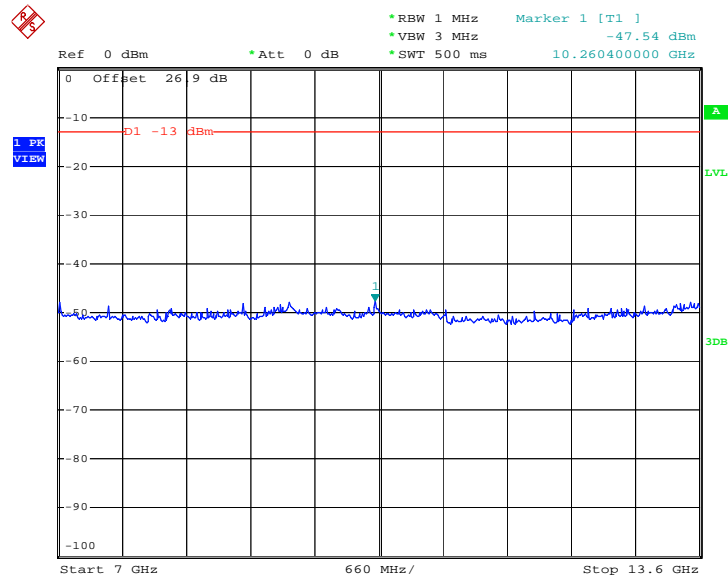

Date: 28.MAR.2009 14:40:07



Conducted Emission Plot between 13.6G-19.1G

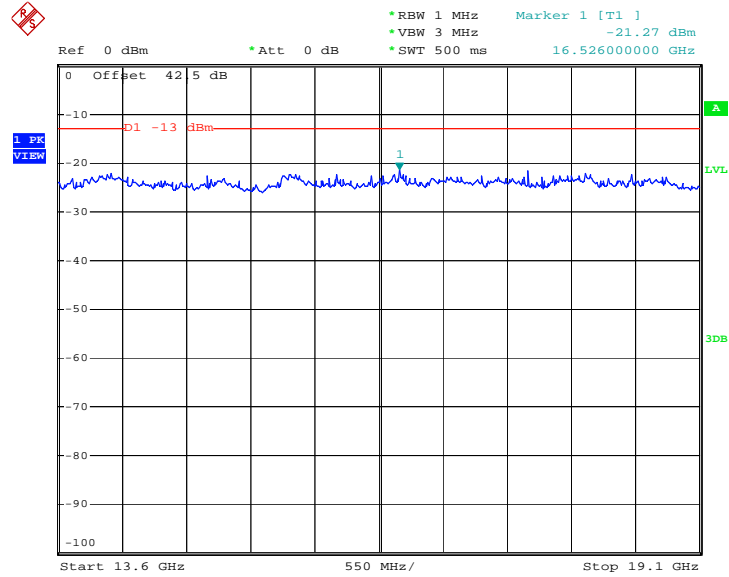

Date: 28.MAR.2009 14:41:37



Band :	WCDMA Band IV	Channel :	CH1413
Test Mode :	WCDMA Link		

Conducted Emission Plot between 30M-1G

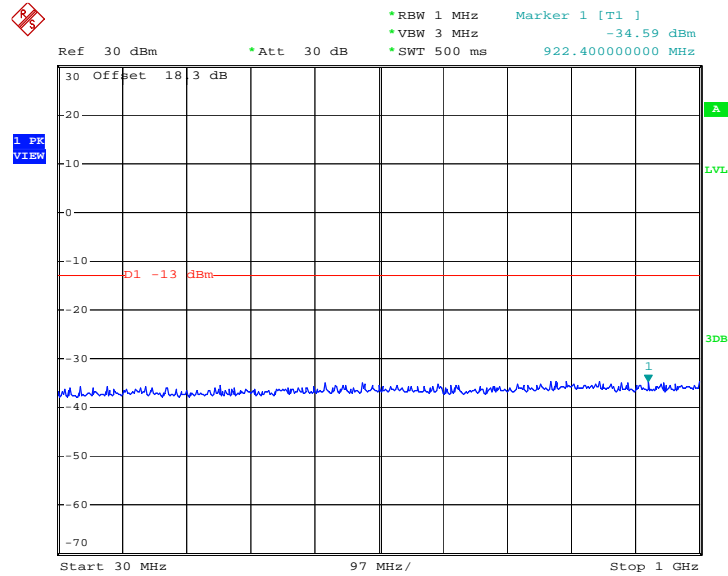

Date: 28.MAR.2009 14:54:54

Conducted Emission Plot between 1GHz ~ 3GHz

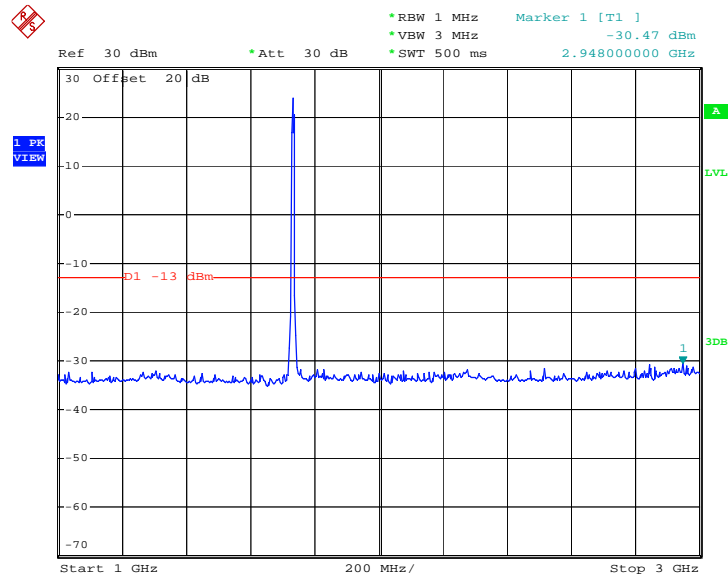

Date: 28.MAR.2009 14:54:25



Conducted Emission Plot between 3GHz ~ 7GHz

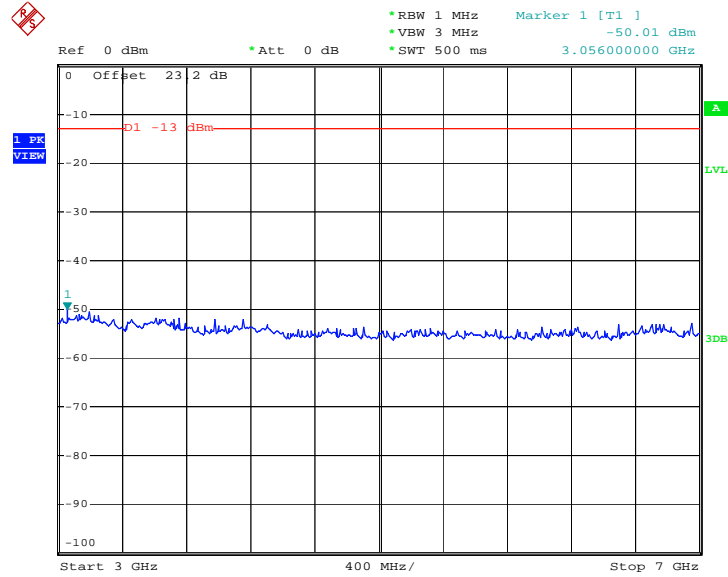

Date: 28.MAR.2009 14:52:51

Conducted Emission Plot between 7G-13.6G

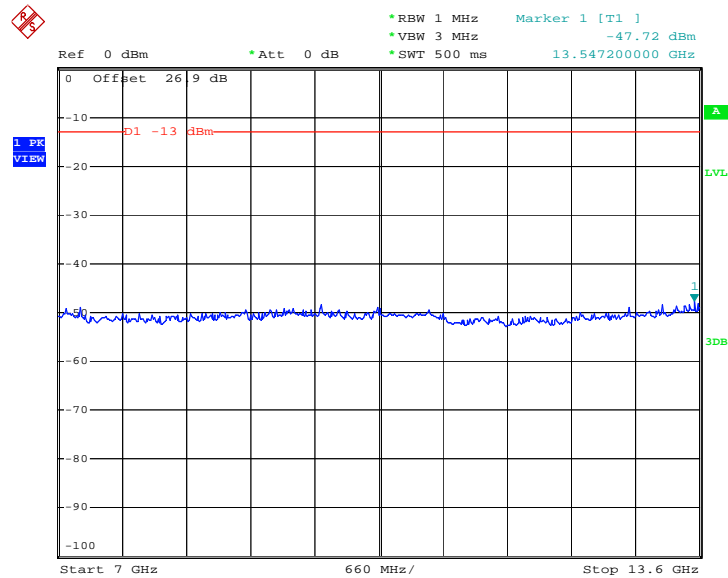

Date: 28.MAR.2009 14:52:03



Conducted Emission Plot between 13.6G-18G

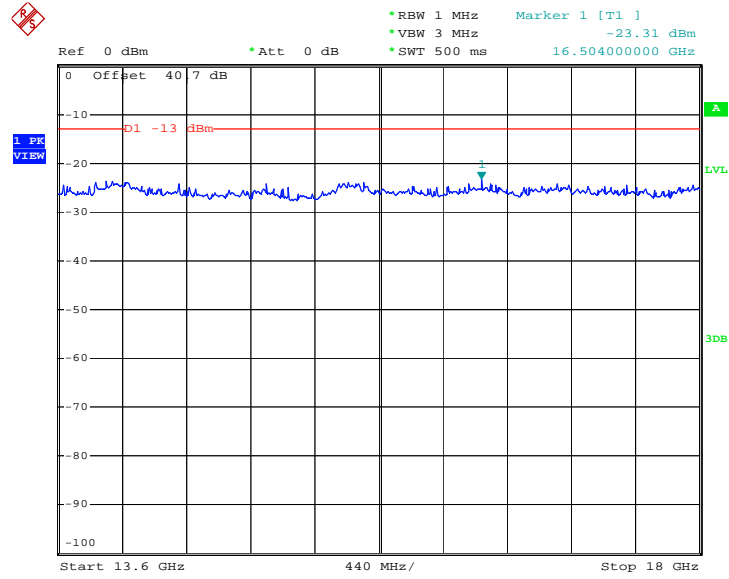

Date: 28.MAR.2009 14:51:29

3.5 Field Strength of Spurious Radiation Measurement

3.5.1 Description of Field Strength of Spurious Radiated Measurement

The radiated spurious emission was measured by substitution method according to ANSI / TIA / EIA-603-C-2004. The power of any emission outside of the authorized operating frequency ranges must be attenuated below the transmitter power (P) by a factor of at least $43 + 10 \log (P)$ dB. The spectrum is scanned from 30 MHz up to a frequency including its 10th harmonic.

3.5.2 Measuring Instruments

See list of measuring instruments of this test report.

3.5.3 Test Procedures

1. The EUT was placed on a rotatable wooden table with 0.8 meter about ground.
2. The EUT was set 3 meters from the receiving antenna, which was mounted on the antenna tower.
3. The table was rotated 360 degrees to determine the position of the highest spurious emission.
4. The height of the receiving antenna is varied between one meter and four meters to search the maximum spurious emission for both horizontal and vertical polarizations.
5. Taking the record of maximum spurious emission.
6. A horn antenna was substituted in place of the EUT and was driven by a signal generator.
7. Tune the output power of signal generator to the same emission level with EUT maximum spurious emission.
8. Taking the record of output power at antenna port.
9. Repeat step 7 to step 8 for another polarization.
10. Emission level (dBm) = output power + substitution Gain.

3.5.4 Test Setup

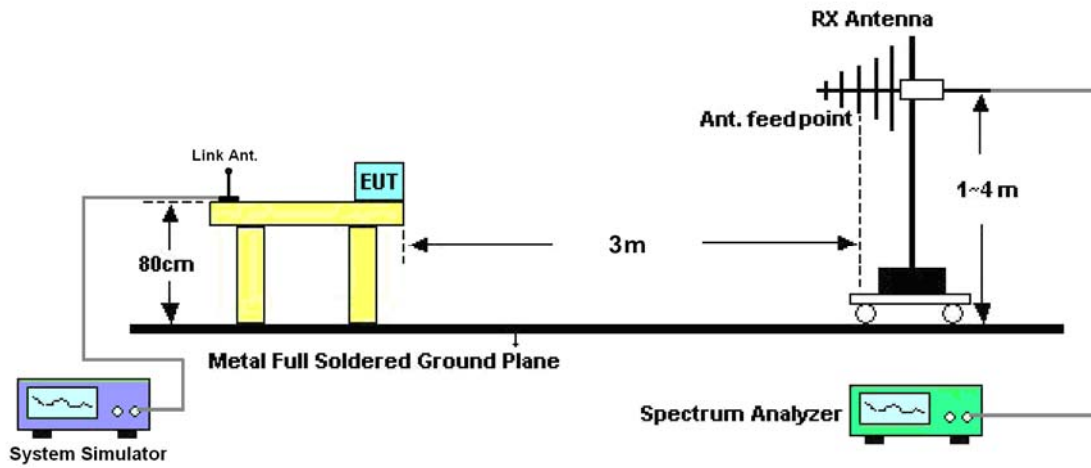



3.5.5 Test Result of Field Strength of Spurious Radiated

Band :	GSM850	Temperature :	22~23°C
Test Mode :	GSM Link for PDA Phone 1	Relative Humidity :	56~57%
Test Engineer :	Kay Wang	Polarization :	Horizontal
Remark :	Spurious emissions within 30-1000MHz were found more than 20dB below limit line.		

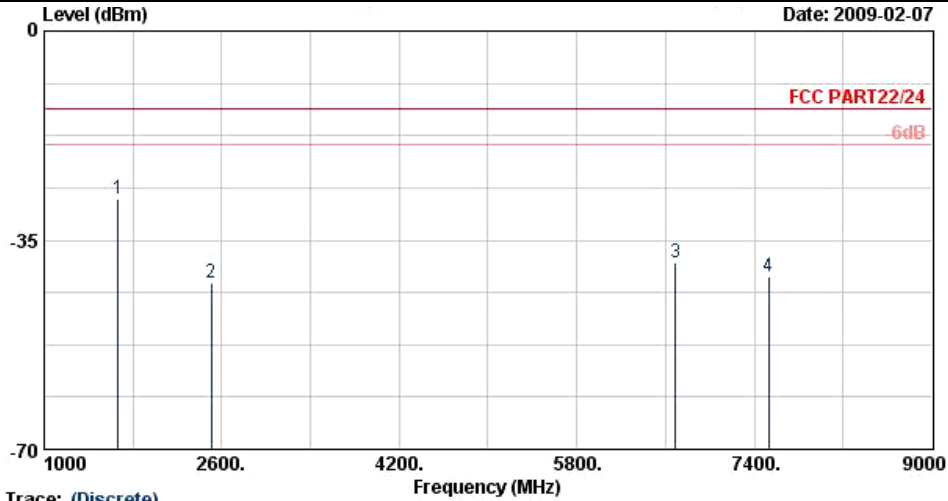

Trace: (Discrete)
 Site : 03CH07-HY
 Condition : FCC PART22/24 HF-EIRP(080306) HORIZONTAL
 Project : FG 920318

Frequency (MHz)	ERP (dBm)	Limit (dBm)	Over Limit (dB)	SPA Reading (dBm)	S.G. Power (dBm)	TX Cable loss (dB)	TX Antenna Gain (dBi)	Polarization (H/V)	Result
1669	-28.18	-13	-15.18	-36.84	-27.19	3.39	4.55	H	Pass
2509	-42.23	-13	-29.23	-50.06	-42.29	3.71	5.92	H	Pass
6690	-38.87	-13	-25.87	-60.68	-41.06	5.22	9.56	H	Pass
7530	-41.20	-13	-28.20	-65.32	-42.54	6.22	9.71	H	Pass



Band :	GSM850	Temperature :	22~23°C
Test Mode :	GSM Link for PDA Phone 1	Relative Humidity :	56~57%
Test Engineer :	Kay Wang	Polarization :	Vertical
Remark :	Spurious emissions within 30-1000MHz were found more than 20dB below limit line.		

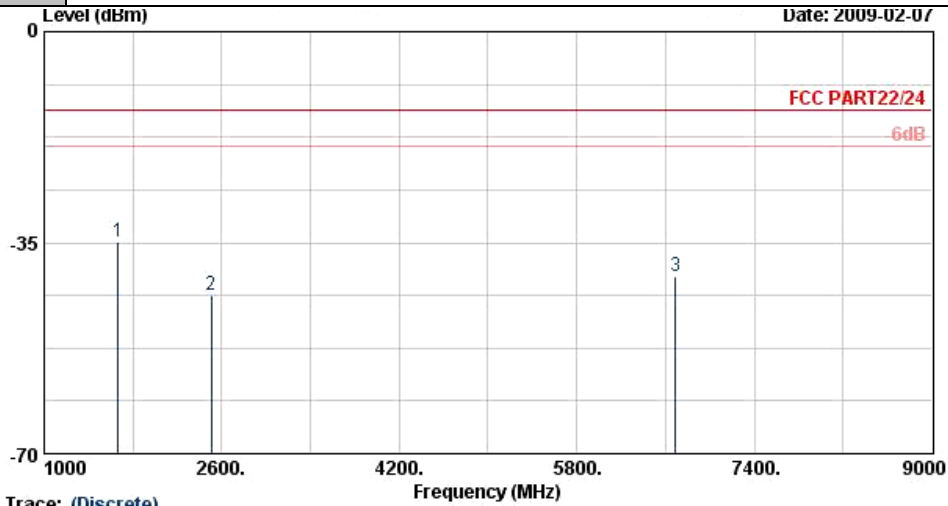

Site : 03CH07-HY
 Condition : FCC PART22/24 HF-EIRP(080306) VERTICAL
 Project : FG 920318

Frequency (MHz)	ERP (dBm)	Limit (dBm)	Over Limit (dB)	SPA Reading (dBm)	S.G. Power (dBm)	TX Cable loss (dB)	TX Antenna Gain (dBi)	Polarization (H/V)	Result
1669	-34.89	-13	-21.89	-40.91	-33.51	3.39	4.16	V	Pass
2506	-43.70	-13	-30.70	-54.17	-43.56	3.71	5.72	V	Pass
6690	-40.71	-13	-27.71	-61.93	-43.96	5.22	10.62	V	Pass



Band :	GSM850	Temperature :	22~23°C
Test Mode :	EDGE Link for PDA Phone 1	Relative Humidity :	56~57%
Test Engineer :	Kay Wang	Polarization :	Horizontal
Remark :	Spurious emissions within 30-1000MHz were found more than 20dB below limit line.		

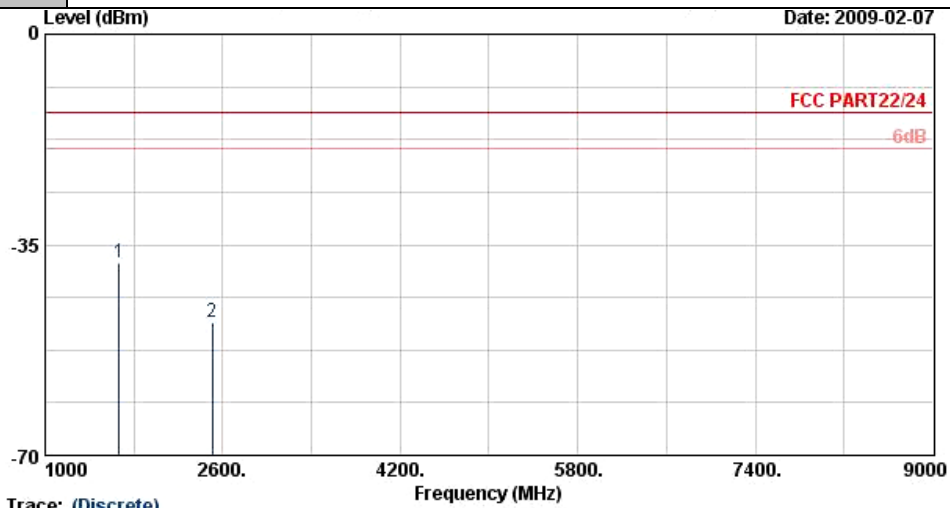

Trace: (Discrete)
 Site : 03CH07-HY
 Condition : FCC PART22/24 HF-EIRP(080306) HORIZONTAL
 Project : FG 920318

Frequency (MHz)	ERP (dBm)	Limit (dBm)	Over Limit (dB)	SPA Reading (dBm)	S.G. Power (dBm)	TX Cable loss (dB)	TX Antenna Gain (dBi)	Polarization (H/V)	Result
1669	-37.99	-13	-24.99	-46.06	-37	3.39	4.55	H	Pass
2509	-47.90	-13	-34.90	-58.04	-47.96	3.71	5.92	H	Pass



Band :	GSM850	Temperature :	22~23°C
Test Mode :	EDGE Link for PDA Phone 1	Relative Humidity :	56~57%
Test Engineer :	Kay Wang	Polarization :	Vertical
Remark :	Spurious emissions within 30-1000MHz were found more than 20dB below limit line.		

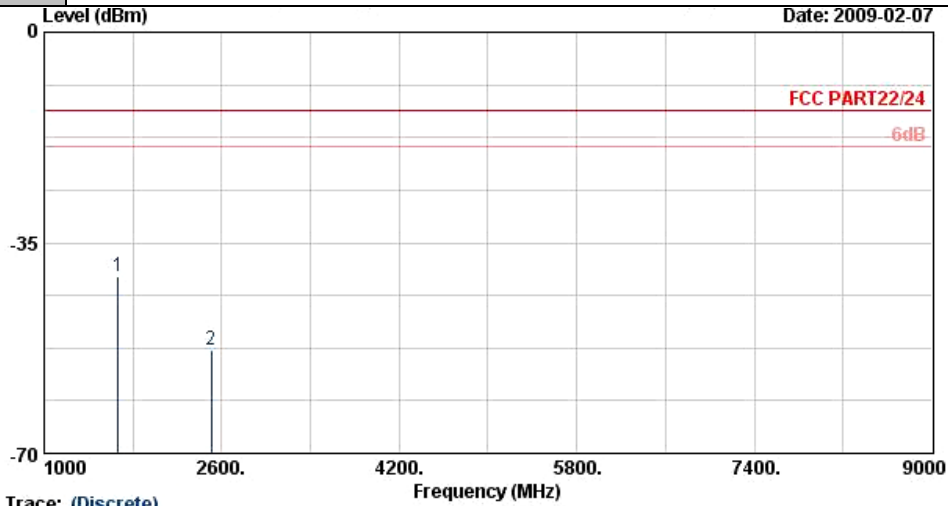

Trace: (Discrete)
 Site : 03CH07-HY
 Condition : FCC PART22/24 HF-EIRP(080306) VERTICAL
 Project : FG 920318

Frequency (MHz)	ERP (dBm)	Limit (dBm)	Over Limit (dB)	SPA Reading (dBm)	S.G. Power (dBm)	TX Cable loss (dB)	TX Antenna Gain (dBi)	Polarization (H/V)	Result
1669	-40.59	-13	-27.59	-46.45	-39.21	3.39	4.16	V	Pass
2509	-52.82	-13	-39.82	-63.41	-52.68	3.71	5.72	V	Pass



Band :	GSM850	Temperature :	22~23°C
Test Mode :	GSM Link for PDA Phone 2	Relative Humidity :	56~57%
Test Engineer :	Kay Wang	Polarization :	Horizontal
Remark :	Spurious emissions within 30-1000MHz were found more than 20dB below limit line.		

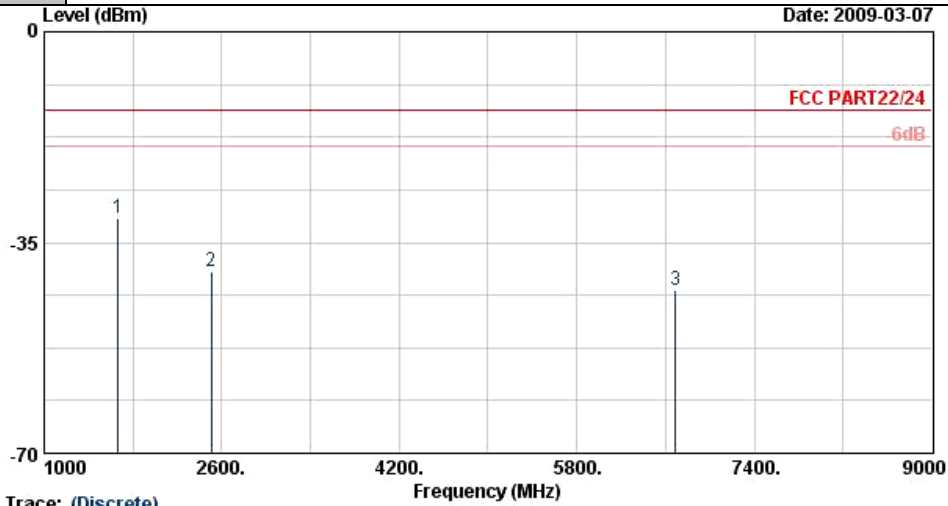

Trace: (Discrete)
 Site : 03CH07-HY
 Condition : FCC PART22/24 HF-EIRP(080306) HORIZONTAL
 Project : FG920318

Frequency (MHz)	ERP (dBm)	Limit (dBm)	Over Limit (dB)	SPA Reading (dBm)	S.G. Power (dBm)	TX Cable loss (dB)	TX Antenna Gain (dBi)	Polarization (H/V)	Result
1669	-30.84	-13	-17.84	-39.15	-29.85	3.39	4.55	H	Pass
2509	-39.94	-13	-26.94	-48.4	-40	3.71	5.92	H	Pass
6690	-42.82	-13	-29.82	-64.63	-45.01	5.22	9.56	H	Pass



Band :	GSM850	Temperature :	22~23°C
Test Mode :	GSM Link for PDA Phone 2	Relative Humidity :	56~57%
Test Engineer :	Kay Wang	Polarization :	Vertical
Remark :	Spurious emissions within 30-1000MHz were found more than 20dB below limit line.		

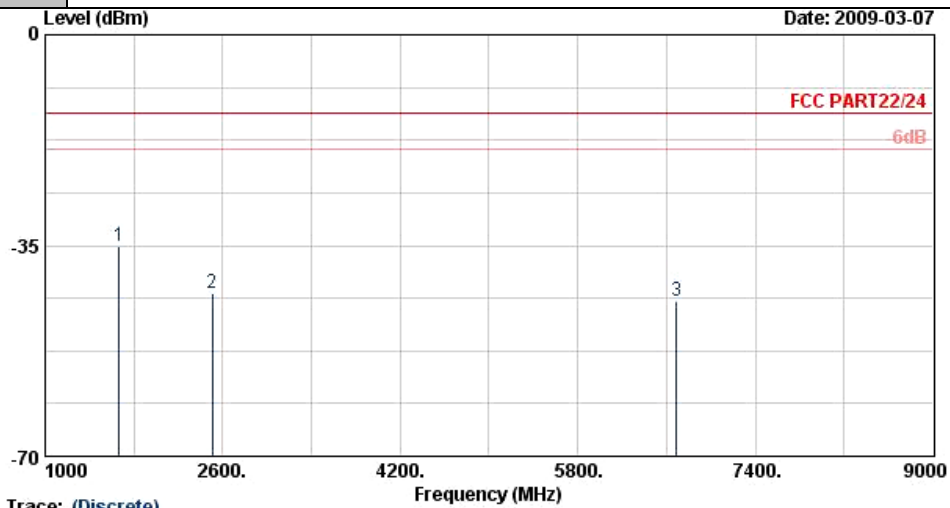

Site : 03CH07-HY
 Condition : FCC PART22/24 HF-EIRP(080306) VERTICAL
 Project : FG 920318

Frequency (MHz)	ERP (dBm)	Limit (dBm)	Over Limit (dB)	SPA Reading (dBm)	S.G. Power (dBm)	TX Cable loss (dB)	TX Antenna Gain (dBi)	Polarization (H/V)	Result
1669	-35.09	-13	-22.09	-45.69	-33.71	3.39	4.16	V	Pass
2509	-42.92	-13	-29.92	-53.62	-42.78	3.71	5.72	V	Pass
6690	-44.28	-13	-31.28	-65.5	-47.53	5.22	10.62	V	Pass



Band :	GSM1900	Temperature :	22~23°C
Test Mode :	GSM Link for PDA Phone 1	Relative Humidity :	56~57%
Test Engineer :	Kay Wang	Polarization :	Horizontal
Remark :	Spurious emissions within 30-1000MHz were found more than 20dB below limit line.		

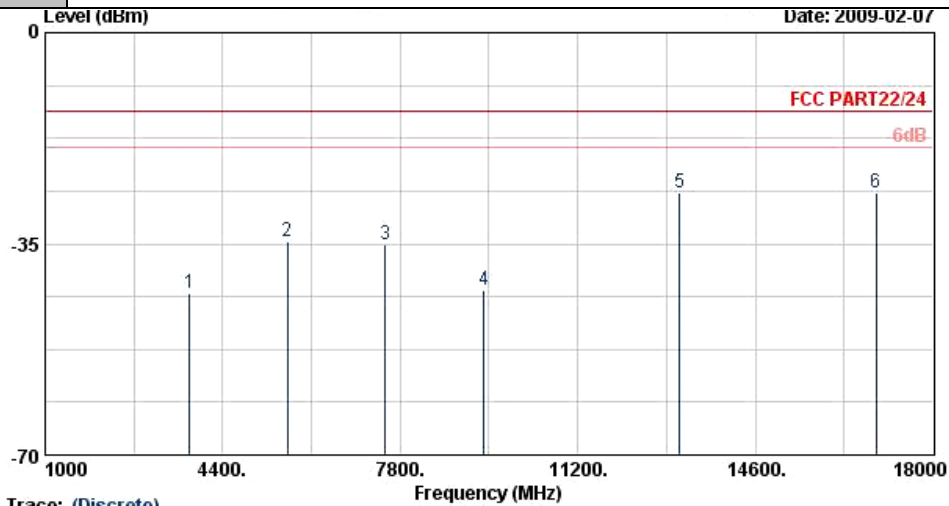

Trace: (Discrete)
 Site : 03CH07-HY
 Condition : FCC PART22/24 HF-EIRP(080306) HORIZONTAL
 Project : FG 920318

Frequency (MHz)	EIRP (dBm)	Limit (dBm)	Over Limit (dB)	SPA Reading (dBm)	S.G. Power (dBm)	TX Cable loss (dB)	TX Antenna Gain (dBi)	Polarization (H/V)	Result
3760	-43.31	-13	-30.31	-58.02	-46.68	4.03	7.40	H	Pass
5636	-34.60	-13	-21.60	-56.29	-39.54	3.87	8.81	H	Pass
7520	-35.05	-13	-22.05	-58.14	-38.93	5.83	9.71	H	Pass
9396	-42.67	-13	-29.67	-64.83	-47.37	6.02	10.72	H	Pass
13156	-26.57	-13	-13.57	-59	-29.47	8.13	11.03	H	Pass
16917	-26.57	-13	-13.57	-62.33	-26.07	11	10.50	H	Pass



Band :	GSM1900	Temperature :	22~23°C
Test Mode :	GSM Link for PDA Phone 1	Relative Humidity :	56~57%
Test Engineer :	Kay Wang	Polarization :	Vertical
Remark :	Spurious emissions within 30-1000MHz were found more than 20dB below limit line.		

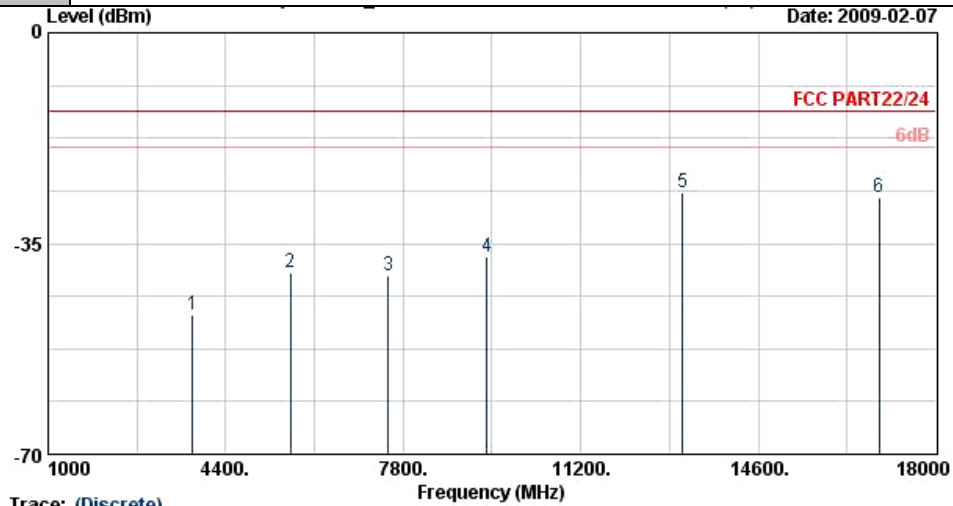

Trace: (Discrete)
 Site : 03CH07-HY
 Condition : FCC PART22/24 HF-EIRP(080306) VERTICAL
 Project : FG 920318

Frequency (MHz)	EIRP (dBm)	Limit (dBm)	Over Limit (dB)	SPA Reading (dBm)	S.G. Power (dBm)	TX Cable loss (dB)	TX Antenna Gain (dBi)	Polarization (H/V)	Result
3760	-46.97	-13	-33.97	-62.47	-50.85	4.03	7.91	V	Pass
5636	-39.82	-13	-26.82	-60.96	-45.72	3.87	9.77	V	Pass
7520	-40.40	-13	-27.40	-62.88	-45.38	5.83	10.81	V	Pass
9396	-37.09	-13	-24.09	-64.92	-42.59	6.02	11.52	V	Pass
13156	-26.66	-13	-13.66	-57.11	-30.69	8.13	12.16	V	Pass
16917	-27.39	-13	-14.39	-62.89	-26.99	11	10.60	V	Pass



Band :	GSM1900	Temperature :	22~23°C
Test Mode :	EDGE Link for PDA Phone 1	Relative Humidity :	56~57%
Test Engineer :	Kay Wang	Polarization :	Horizontal
Remark :	Spurious emissions within 30-1000MHz were found more than 20dB below limit line.		

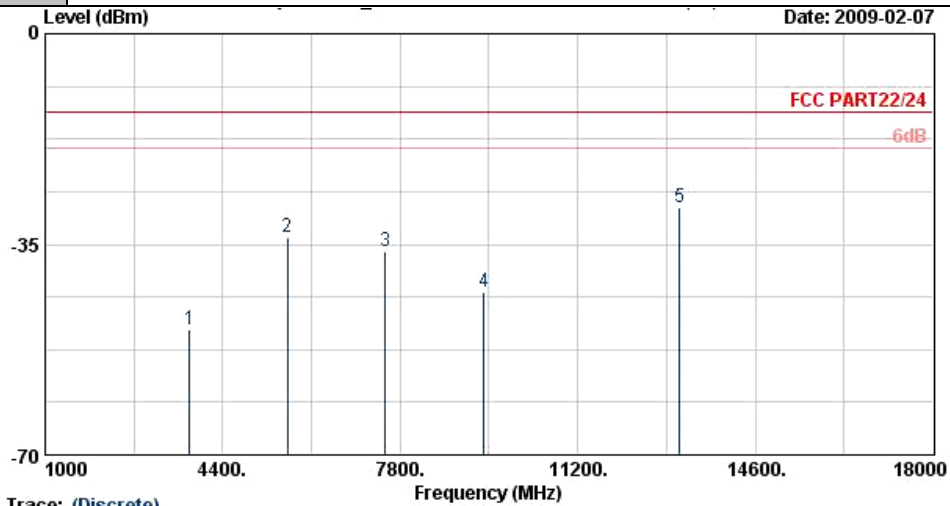

Site : 03CH07-HY
 Condition : FCC PART22/24 HF-EIRP(080306) HORIZONTAL
 Project : FG 920318

Frequency (MHz)	EIRP (dBm)	Limit (dBm)	Over Limit (dB)	SPA Reading (dBm)	S.G. Power (dBm)	TX Cable loss (dB)	TX Antenna Gain (dBi)	Polarization (H/V)	Result
3760	-49.08	-13	-36.08	-61.32	-52.45	4.03	7.40	H	Pass
5636	-33.80	-13	-20.80	-55.61	-38.74	3.87	8.81	H	Pass
7520	-36.10	-13	-23.10	-59.02	-39.98	5.83	9.71	H	Pass
9396	-43.03	-13	-30.03	-65.19	-47.73	6.02	10.72	H	Pass
13156	-28.82	-13	-15.82	-61.25	-31.72	8.13	11.03	H	Pass



Band :	GSM1900	Temperature :	22~23°C
Test Mode :	EDGE Link for PDA Phone 1	Relative Humidity :	56~57%
Test Engineer :	Kay Wang	Polarization :	Vertical
Remark :	Spurious emissions within 30-1000MHz were found more than 20dB below limit line.		

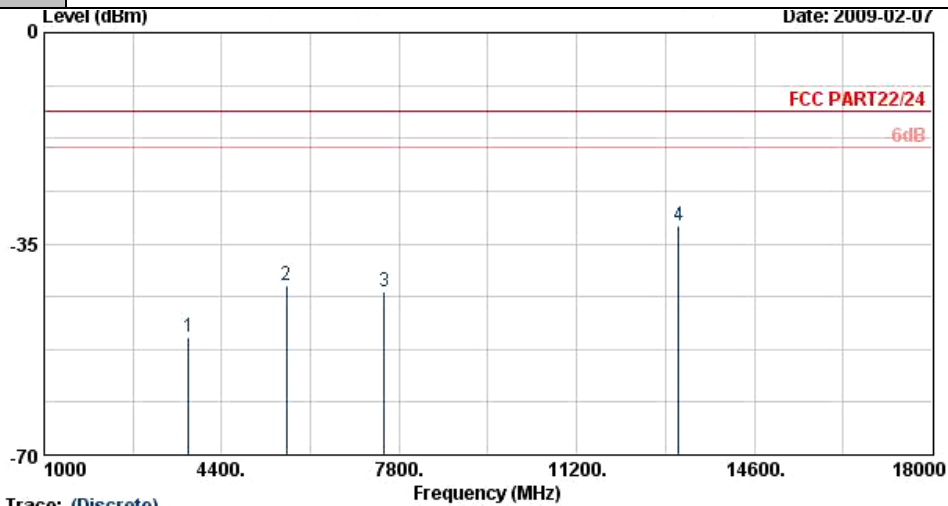

Trace: (Discrete)
 Site : 03CH07-HY
 Condition : FCC PART22/24 HF-EIRP(080306) VERTICAL
 Project : FG 920318

Frequency (MHz)	EIRP (dBm)	Limit (dBm)	Over Limit (dB)	SPA Reading (dBm)	S.G. Power (dBm)	TX Cable loss (dB)	TX Antenna Gain (dBi)	Polarization (H/V)	Result
3760	-50.40	-13	-37.40	-64.64	-54.28	4.03	7.91	V	Pass
5636	-41.80	-13	-28.80	-62.51	-47.7	3.87	9.77	V	Pass
7520	-42.86	-13	-29.86	-64.52	-47.84	5.83	10.81	V	Pass
13156	-32.05	-13	-19.05	-62.5	-36.08	8.13	12.16	V	Pass



Band :	GSM1900	Temperature :	22~23°C
Test Mode :	GSM Link for PDA Phone 2	Relative Humidity :	56~57%
Test Engineer :	Kay Wang	Polarization :	Horizontal
Remark :	Spurious emissions within 30-1000MHz were found more than 20dB below limit line.		

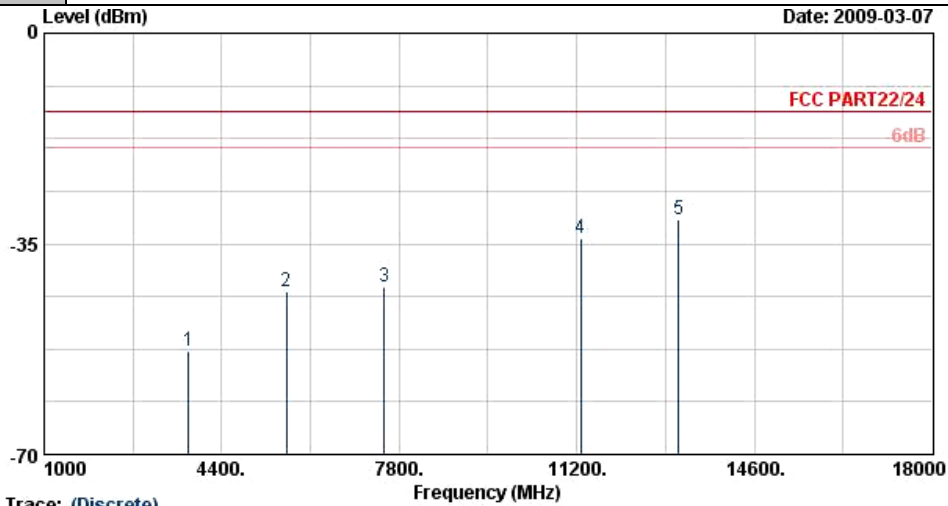

Trace: (Discrete)
 Site : 03CH07-HY
 Condition : FCC PART22/24 HF-EIRP(080306) HORIZONTAL
 Project : FG 920318

Frequency (MHz)	EIRP (dBm)	Limit (dBm)	Over Limit (dB)	SPA Reading (dBm)	S.G. Power (dBm)	TX Cable loss (dB)	TX Antenna Gain (dBi)	Polarization (H/V)	Result
3760	-52.88	-13	-39.88	-63.93	-56.25	4.03	7.40	H	Pass
5636	-43.05	-13	-30.05	-62.73	-47.99	3.87	8.81	H	Pass
7520	-42.18	-13	-29.18	-63.8	-46.06	5.83	9.71	H	Pass
11280	-34.00	-13	-21.00	-65.64	-36.28	8.48	10.76	H	Pass
13156	-30.96	-13	-17.96	-60.39	-33.86	8.13	11.03	H	Pass



Band :	GSM1900	Temperature :	22~23°C
Test Mode :	GSM Link for PDA Phone 2	Relative Humidity :	56~57%
Test Engineer :	Kay Wang	Polarization :	Vertical
Remark :	Spurious emissions within 30-1000MHz were found more than 20dB below limit line.		

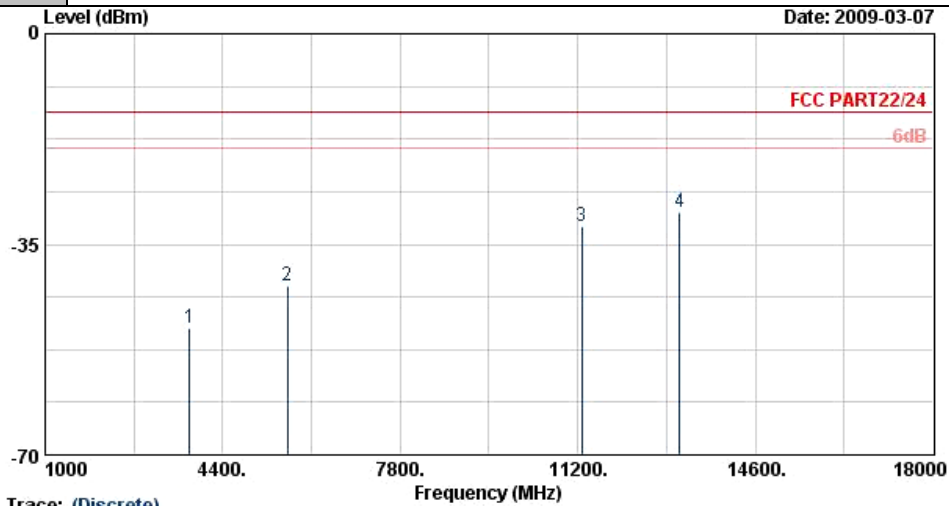

Site : 03CH07-HY
 Condition : FCC PART22/24 HF-EIRP(080306) VERTICAL
 Project : FG 920318

Frequency (MHz)	EIRP (dBm)	Limit (dBm)	Over Limit (dB)	SPA Reading (dBm)	S.G. Power (dBm)	TX Cable loss (dB)	TX Antenna Gain (dBi)	Polarization (H/V)	Result
3760	-48.93	-13	-35.93	-63.76	-52.81	4.03	7.91	V	Pass
5636	-42.00	-13	-29.00	-62.71	-47.9	3.87	9.77	V	Pass
11280	-31.97	-13	-18.97	-64.55	-34.85	8.48	11.36	V	Pass
13156	-29.78	-13	-16.78	-57.23	-33.81	8.13	12.16	V	Pass



Band :	WCDMA Band IV	Temperature :	22~23°C
Test Mode :	WCDMA Link for PDA Phone 1	Relative Humidity :	56~57%
Test Engineer :	Kay Wang	Polarization :	Horizontal
Remark :	Spurious emissions within 30-1000MHz were found more than 20dB below limit line.		

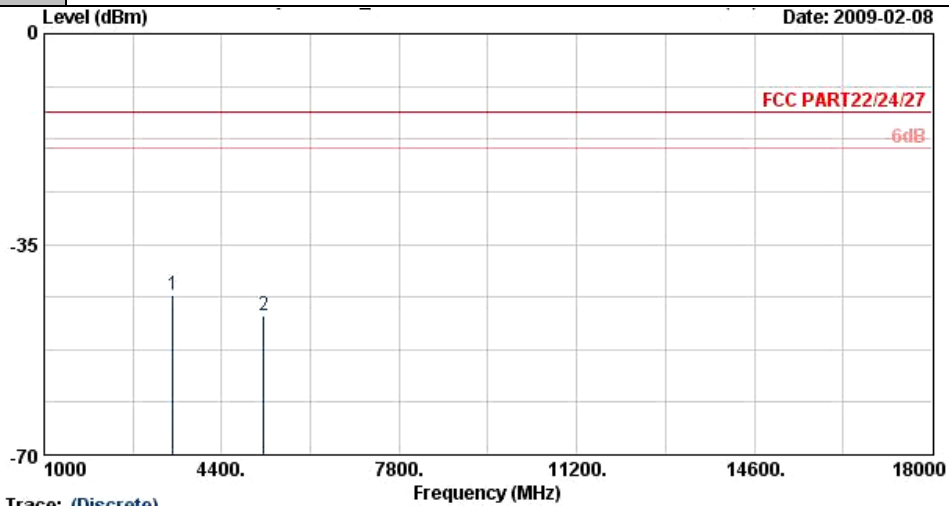

Trace: (Discrete)
 Site : 03CH07-HY
 Condition : FCC PART22/24/27 HF-EIRP(080306) HORIZONTAL
 Project : FG 920318

Frequency (MHz)	ERP (dBm)	Limit (dBm)	Over Limit (dB)	SPA Reading (dBm)	S.G. Power (dBm)	TX Cable loss (dB)	TX Antenna Gain (dBi)	Polarization (H/V)	Result
3460	-43.37	-13	-30.37	-57.51	-46.17	4.48	7.28	H	Pass
5200	-46.84	-13	-33.84	-64.42	-50.09	5.33	8.58	H	Pass



Band :	WCDMA Band IV	Temperature :	22~23°C
Test Mode :	WCDMA Link for PDA Phone 1	Relative Humidity :	56~57%
Test Engineer :	Kay Wang	Polarization :	Vertical
Remark :	Spurious emissions within 30-1000MHz were found more than 20dB below limit line.		

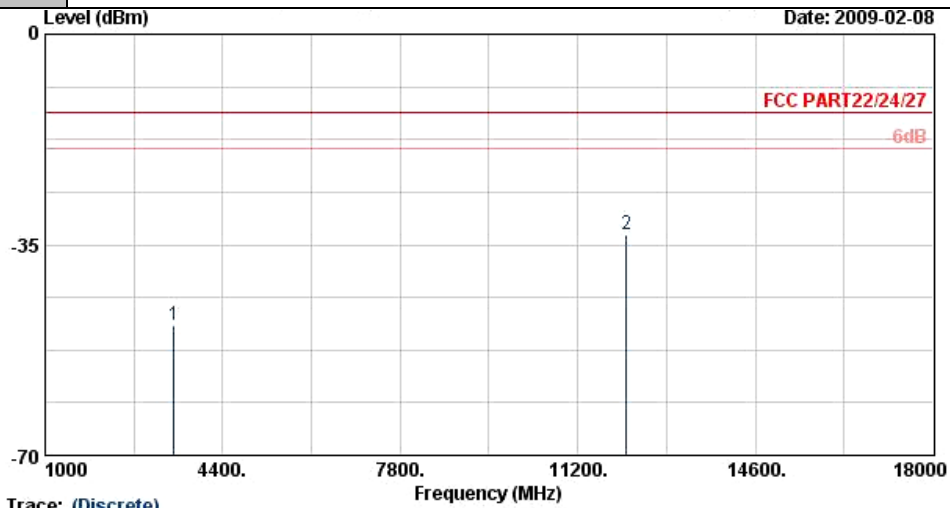

Site : 03CH07-HY
 Condition : FCC PART22/24/27 HF-EIRP(080306) VERTICAL
 Project : FG 920318

Frequency (MHz)	ERP (dBm)	Limit (dBm)	Over Limit (dB)	SPA Reading (dBm)	S.G. Power (dBm)	TX Cable loss (dB)	TX Antenna Gain (dBi)	Polarization (H/V)	Result
3460	-48.45	-13	-35.45	-62.91	-51.62	4.48	7.65	V	Pass
12128	-33.33	-13	-20.33	-66.52	-37.14	8.59	12.40	V	Pass



Band :	WCDMA Band IV	Temperature :	22~23°C
Test Mode :	WCDMA Link for PDA Phone 2	Relative Humidity :	56~57%
Test Engineer :	Kay Wang	Polarization :	Horizontal
Remark :	Spurious emissions within 30-1000MHz were found more than 20dB below limit line.		

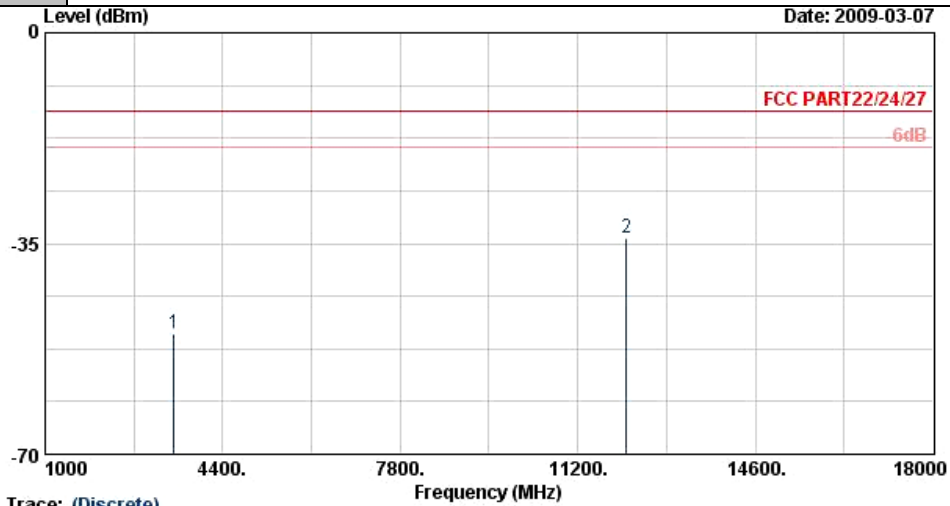

Trace: (Discrete)
 Site : 03CH07-HY
 Condition : FCC PART22/24/27 HF-EIRP(080306) HORIZONTAL
 Project : FG 920318

Frequency (MHz)	ERP (dBm)	Limit (dBm)	Over Limit (dB)	SPA Reading (dBm)	S.G. Power (dBm)	TX Cable loss (dB)	TX Antenna Gain (dBi)	Polarization (H/V)	Result
3460	-50.04	-13	-37.04	-61.97	-52.84	4.48	7.28	H	Pass
12128	-34.05	-13	-21.05	-65.82	-36.46	8.59	11.00	H	Pass



Band :	WCDMA Band IV	Temperature :	22~23°C
Test Mode :	WCDMA Link for PDA Phone 2	Relative Humidity :	56~57%
Test Engineer :	Kay Wang	Polarization :	Vertical
Remark :	Spurious emissions within 30-1000MHz were found more than 20dB below limit line.		

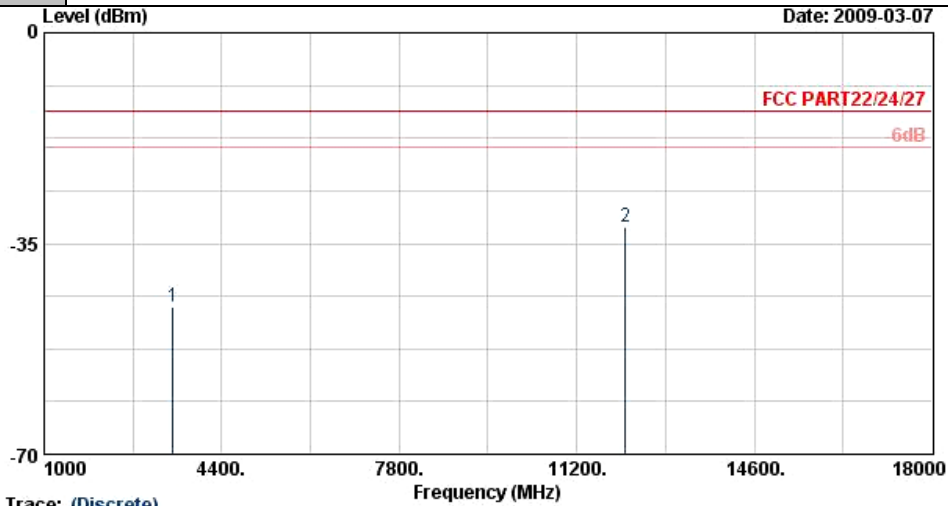

Trace: (Discrete)
 Site : 03CH07-HY
 Condition : FCC PART22/24/27 HF-EIRP(080306) VERTICAL
 Project : FG 920318

Frequency (MHz)	ERP (dBm)	Limit (dBm)	Over Limit (dB)	SPA Reading (dBm)	S.G. Power (dBm)	TX Cable loss (dB)	TX Antenna Gain (dBi)	Polarization (H/V)	Result
3460	-45.66	-13	-32.66	-61.23	-48.83	4.48	7.65	V	Pass
12128	-32.24	-13	-19.24	-60.8	-36.05	8.59	12.40	V	Pass



Band :	GSM850	Temperature :	22~23°C
Test Mode :	GSM + WLAN Link for PDA Phone 1	Relative Humidity :	56~57%
Test Engineer :	Kay Wang	Polarization :	Horizontal
Remark :	Spurious emissions within 30-1000MHz were found more than 20dB below limit line.		

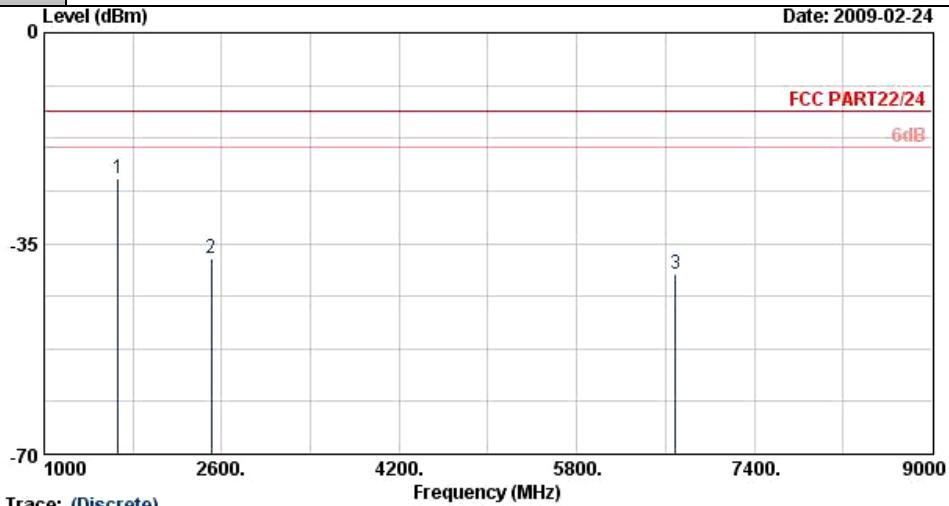

Trace: (Discrete)
 Site : 03CH07-HY
 Condition : FCC PART22/24 HF-EIRP(080306) HORIZONTAL
 Project : FG 920318

Frequency (MHz)	ERP (dBm)	Limit (dBm)	Over Limit (dB)	SPA Reading (dBm)	S.G. Power (dBm)	TX Cable loss (dB)	TX Antenna Gain (dBi)	Polarization (H/V)	Result
1669	-24.29	-13	-11.29	-32.94	-23.3	3.39	4.55	H	Pass
2509	-37.57	-13	-24.57	-45.73	-37.63	3.71	5.92	H	Pass
6690	-40.00	-13	-27.00	-61.81	-42.19	5.22	9.56	H	Pass



Band :	GSM850	Temperature :	22~23°C
Test Mode :	GSM + WLAN Link for PDA Phone 1	Relative Humidity :	56~57%
Test Engineer :	Kay Wang	Polarization :	Vertical
Remark :	Spurious emissions within 30-1000MHz were found more than 20dB below limit line.		

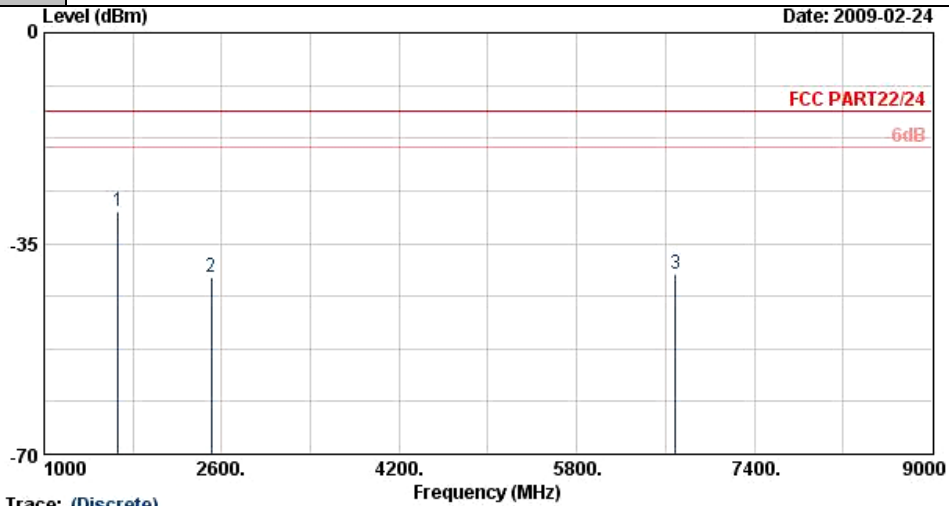

Site : 03CH07-HY
 Condition : FCC PART22/24 HF-EIRP(080306) VERTICAL
 Project : FG 920318

Frequency (MHz)	ERP (dBm)	Limit (dBm)	Over Limit (dB)	SPA Reading (dBm)	S.G. Power (dBm)	TX Cable loss (dB)	TX Antenna Gain (dBi)	Polarization (H/V)	Result
1669	-29.65	-13	-16.65	-40.59	-28.27	3.39	4.16	V	Pass
2509	-40.50	-13	-27.50	-51.47	-40.36	3.71	5.72	V	Pass
6690	-40.12	-13	-27.12	-61.34	-43.37	5.22	10.62	V	Pass



Band :	GSM850	Temperature :	22~23°C
Test Mode :	GSM + BT Link for PDA Phone 1	Relative Humidity :	56~57%
Test Engineer :	Kay Wang	Polarization :	Horizontal
Remark :	Spurious emissions within 30-1000MHz were found more than 20dB below limit line.		

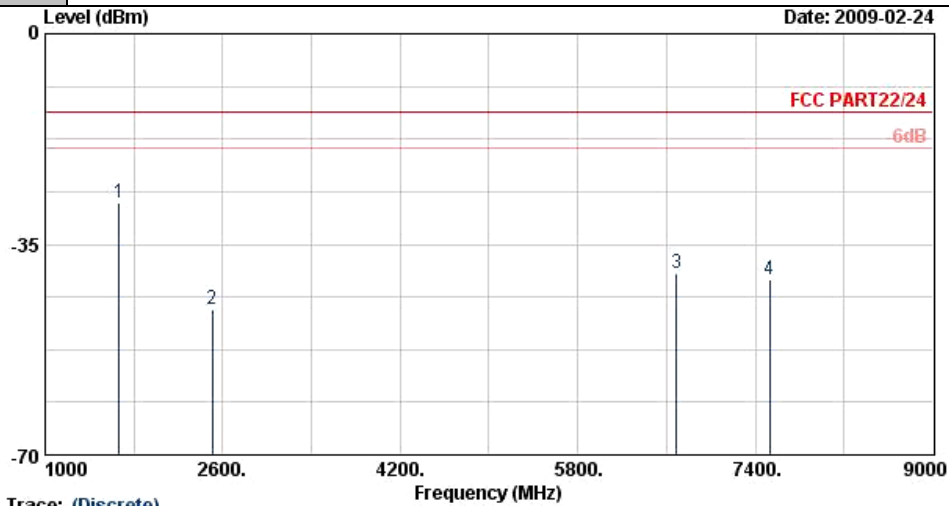

Site : 03CH07-HY
 Condition : FCC PART22/24 HF-EIRP(080306) HORIZONTAL
 Project : FG 920318

Frequency (MHz)	ERP (dBm)	Limit (dBm)	Over Limit (dB)	SPA Reading (dBm)	S.G. Power (dBm)	TX Cable loss (dB)	TX Antenna Gain (dBi)	Polarization (H/V)	Result
1669	-28.12	-13	-15.12	-36.78	-27.13	3.39	4.55	H	Pass
2509	-45.79	-13	-32.79	-53.29	-45.85	3.71	5.92	H	Pass
6690	-39.87	-13	-26.87	-61.68	-42.06	5.22	9.56	H	Pass
7530	-40.75	-13	-27.75	-64.87	-42.09	6.22	9.71	H	Pass



Band :	GSM850	Temperature :	22~23°C
Test Mode :	GSM + BT Link for PDA Phone 1	Relative Humidity :	56~57%
Test Engineer :	Kay Wang	Polarization :	Vertical
Remark :	Spurious emissions within 30-1000MHz were found more than 20dB below limit line.		

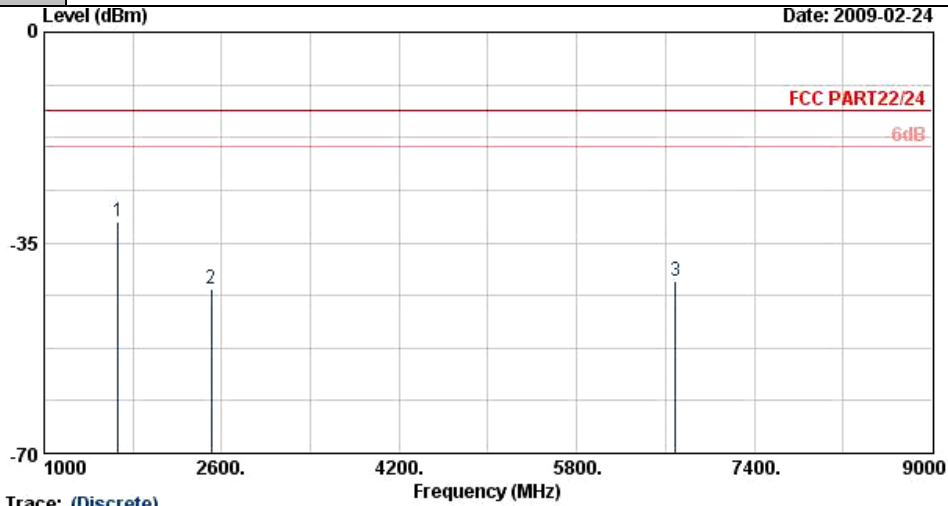

Trace: (Discrete)
 Site : 03CH07-HY
 Condition : FCC PART22/24 HF-EIRP(080306) VERTICAL
 Project : FG 920318

Frequency (MHz)	ERP (dBm)	Limit (dBm)	Over Limit (dB)	SPA Reading (dBm)	S.G. Power (dBm)	TX Cable loss (dB)	TX Antenna Gain (dBi)	Polarization (H/V)	Result
1669	-31.51	-13	-18.51	-42.34	-30.13	3.39	4.16	V	Pass
2509	-42.74	-13	-29.74	-53.44	-42.6	3.71	5.72	V	Pass
6690	-41.45	-13	-28.45	-62.67	-44.7	5.22	10.62	V	Pass

3.6 Frequency Stability Measurement

3.6.1 Description of Frequency Stability Measurement

The frequency stability shall be measured by variation of ambient temperature and variation of primary supply voltage to ensure that the fundamental emission stays within the authorized frequency block. The frequency stability of the transmitter shall be maintained within $\pm 0.00025\%$ ($\pm 2.5\text{ppm}$) of the center frequency.

3.6.2 Measuring Instruments

See list of measuring instruments of this test report.

3.6.3 Test Procedures for Temperature Variation

1. The EUT was set up in the thermal chamber and connected with the base station.
2. With power OFF, the temperature was decreased to -30°C and the EUT was stabilized for three hours. Power was applied and the maximum change in frequency was recorded within one minute.
3. With power OFF, the temperature was raised in 10°C step up to 50°C . The EUT was stabilized at each step for at least half an hour. Power was applied and the maximum frequency change was recorded within one minute.
4. If the EUT can not be turned on at -30°C , the testing lowest temperature will be raised in 10°C step until the EUT can be turned on.

3.6.4 Test Procedures for Voltage Variation

1. The EUT was placed in a temperature chamber at $25\pm 5^{\circ}\text{C}$ and connected with the base station.
2. The power supply voltage to the EUT was varied from BEP to 115% of the nominal value measured at the input to the EUT.
3. The variation in frequency was measured for the worst case.

3.6.5 Test Setup

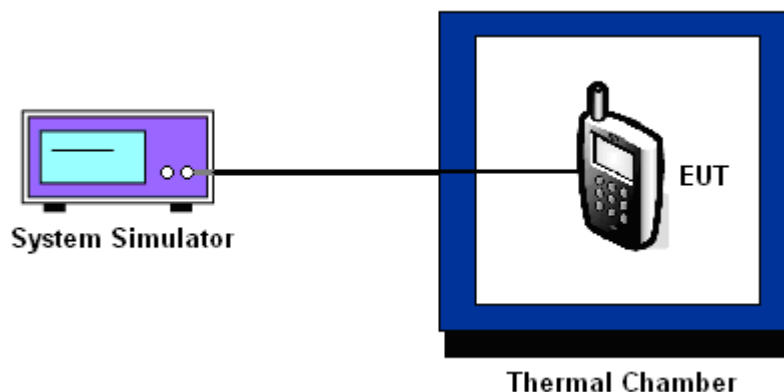



3.6.6 Test Result of Temperature Variation

Band :	GSM 850	Channel :	189
Limit (ppm) :	2.5		

Temperature (°C)	GSM		EDGE 8		Result
	Freq. Dev. (Hz)	Deviation (ppm)	Freq. Dev. (Hz)	Deviation (ppm)	
-30	-50	-0.06	-56	-0.07	PASS
-20	-19	-0.02	-24	-0.03	
-10	-16	-0.02	-22	-0.03	
0	-33	-0.04	-26	-0.03	
10	-37	-0.04	13	0.02	
20	-28	-0.03	30	0.04	
30	-24	-0.03	33	0.04	
40	-35	-0.04	-32	-0.04	
50	-44	-0.05	-38	-0.04	

Band :	GSM 1900	Channel :	661
Limit (ppm) :	2.5		

Temperature (°C)	GSM		EDGE 8		Result
	Freq. Dev. (Hz)	Deviation (ppm)	Freq. Dev. (Hz)	Deviation (ppm)	
-30	-88	-0.05	-59	-0.03	PASS
-20	-73	-0.04	-58	-0.03	
-10	-90	-0.05	-52	-0.03	
0	-82	-0.04	-67	-0.04	
10	-84	-0.04	-31	-0.02	
20	-64	-0.03	-24	-0.01	
30	-70	-0.04	42	0.02	
40	-86	-0.05	-60	-0.03	
50	-94	-0.05	-71	-0.04	



Band :	WCDMA Band IV	Channel :	1413
Limit (ppm) :	2.5		

Temperature (°C)	WCDMA		Result
	Freq. Dev. (Hz)	Deviation (ppm)	
-30	-30	-0.02	PASS
-20	29	0.02	
-10	-18	-0.01	
0	-23	-0.01	
10	-29	-0.02	
20	-54	-0.03	
30	-47	-0.03	
40	-38	-0.02	
50	-33	-0.02	

3.6.7 Test Result of Voltage Variation

Band & Channel	Mode	Voltage (Volt)	Freq. Dev. (Hz)	Deviation (ppm)	Limit (ppm)	Result
GSM 850 CH189	GSM	3.8	-34	-0.04	2.5	PASS
		BEP	-23	-0.03		
		4.2	-30	-0.04		
	EDGE 8	3.8	-39	-0.05		
		BEP	-32	-0.04		
		4.2	-35	-0.04		
GSM 1900 CH661	GSM	3.8	-55	-0.03		
		BEP	63	0.03		
		4.2	-58	-0.03		
	EDGE 8	3.8	-68	-0.04		
		BEP	-56	-0.03		
		4.2	-52	-0.03		
WCDMA Band IV CH1413	WCDMA	3.8	-39	-0.02		
		BEP	-51	-0.03		
		4.2	-46	-0.03		

Remark:

1. Normal Voltage = 3.8V.
2. Battery End Point (BEP) = 3.6 V.



4 List of Measuring Equipment

Instrument	Manufacturer	Model No.	Serial No.	Characteristics	Calibration Date	Due Date	Remark
System Simulator	R&S	CMU200	105934	N/A	Nov. 08, 2008	Nov. 07, 2009	Conducted (TH02-HY)
Spectrum Analyzer	R&S	FSP40	100055	9kHz~40GHz	Jun. 26, 2008	Jun. 25, 2009	Conducted (TH02-HY)
Power Meter	Agilent	E4416A	GB41292344	N/A	Feb. 19, 2009	Feb. 18, 2010	Conducted (TH02-HY)
Power Sensor	Agilent	E9327A	US40441548	N/A	Feb. 19, 2009	Feb. 18, 2010	Conducted (TH02-HY)
Thermal Chamber	TEN BILLION	TTH-D35P	TBN-930701	N/A	Aug. 01, 2008	Jul. 31, 2009	Conducted (TH02-HY)
Bilog Antenna	SCHAFFNER	CBL6111C	2726	30MHz~1GHz	Nov. 20, 2008	Nov. 19, 2009	Radiation (03CH07-HY)
Spectrum Analyzer	R&S	FSP	101067	9kHz~30GHz	Dec. 02, 2008	Dec. 01, 2009	Radiation (03CH07-HY)
Double Ridge Horn Antenna	ESCO	3117	75962	1G~18GHz	Aug. 13, 2008	Aug. 12, 2009	Radiation (03CH07-HY)
Pre Amplifier	Agilent	8449B	3008A02362	1G~26.5GHz	Dec. 17, 2008	Dec. 16, 2009	Radiation (03CH07-HY)
Pre Amplifier	COM-POWER	PA-103A	161241	10~1000MHz. 32dB.GAIN	Mar. 31, 2008	Mar. 30, 2009	Radiation (03CH07-HY)
Double Ridge Horn Antenna	ESCO	3117	66584	1G~18GHz	Aug. 06, 2008	Aug. 05, 2009	Radiation (03CH07-HY)
Loop Antenna	R&S	HFH2-Z2	860004/001	9 kHz~30 MHz	May 22, 2008	May 21, 2010	Radiation (03CH07-HY)
BT Base Station	Anritsu	MT8852B	6K00005722	N/A	Oct. 23, 2007	Oct. 22, 2009	Radiation (03CH07-HY)

5 Uncertainty of Evaluation

Uncertainty of Radiated Emission Measurement (30 MHz ~ 1000 MHz)

Contribution	Uncertainty of x_i		$u(x_i)$
	dB	Probability Distribution	
Receiver reading	0.41	Normal(k=2)	0.21
Antenna factor calibration	0.83	Normal(k=2)	0.42
Cable loss calibration	0.25	Normal(k=2)	0.13
Pre Amplifier Gain calibration	0.27	Normal(k=2)	0.14
RCV/SPA specification	2.50	Rectangular	0.72
Antenna Factor Interpolation for Frequency	1.00	Rectangular	0.29
Site imperfection	1.43	Rectangular	0.83
Mismatch	+0.39/-0.41	U-shaped	0.28
Combined standard uncertainty Uc(y)	1.27		
Measuring uncertainty for a level of confidence of 95% U=2Uc(y)	2.54		

Uncertainty of Radiated Emission Measurement (1 GHz ~ 40 GHz)

Contribution	Uncertainty of x_i		$u(x_i)$	C_i	$C_i * u(x_i)$
	dB	Probability Distribution			
Receiver reading	±0.10	Normal(k=1)	0.10	1	0.10
Antenna factor calibration	±1.70	Normal(k=2)	0.85	1	0.85
Cable loss calibration	±0.50	Normal(k=2)	0.25	1	0.25
Receiver Correction	±2.00	Rectangular	1.15	1	1.15
Antenna Factor Directional	±1.50	Rectangular	0.87	1	0.87
Site imperfection	±2.80	Triangular	1.14	1	1.14
Mismatch Receiver VSWR $\Gamma_1 = 0.197$ Antenna VSWR $\Gamma_2 = 0.194$ Uncertainty = $20 \log(1 - \Gamma_1 * \Gamma_2)$	+0.34/-0.35	U-shaped	0.244	1	0.244
Combined standard uncertainty Uc(y)	2.36				
Measuring uncertainty for a level of confidence of 95% U=2Uc(y)	4.72				

6 Certification of TAF Accreditation



Certificate No. : I.1190-081212

財團法人全國認證基金會
Taiwan Accreditation Foundation

Certificate of Accreditation

This is to certify that

Sporton International Inc.
EMC & Wireless Communications Laboratory
No.52, Hwa Ya 1st Rd., Hwa Ya Technology Park, Kwei-Shan Hsiang, Tao Yuan Hsien,
Taiwan, R.O.C.

is accredited in respect of laboratory

Accreditation Criteria	: ISO/IEC 17025:2005
Accreditation Number	: 1190
Originally Accredited	: December 15, 2003
Effective Period	: January 10, 2007 to January 09, 2010
Accredited Scope	: Testing Field, see described in the Appendix
Specific Accreditation Program	: Accreditation Program for Designated Testing Laboratory for Commodities Inspection Accreditation Program for Telecommunication Equipment Testing Laboratory Accreditation Program for BSMI Mutual Recognition Arrangement with Foreign Authorities



Jay-San Chen
President, Taiwan Accreditation Foundation
Date : December 12, 2008

PI, total 18 pages

The Appendix forms an integral part of this Certificate, which shall be invalid when use without the Appendix



Appendix A. Photographs of EUT

Please refer to Sporton report number EP920318 as below.