

User Manual

smart
SII
SO
SI
PI

Please Read Before Proceeding

THIS DEVICE IS NOT FULLY CHARGED WHEN YOU TAKE IT OUT OF THE BOX.

DO NOT REMOVE THE BATTERY PACK WHEN THE DEVICE IS CHARGING.

YOUR WARRANTY IS INVALIDATED IF YOU OPEN OR TAMPER WITH THE DEVICE'S OUTER CASING.

PRIVACY RESTRICTIONS

Some countries require full disclosure of recorded telephone conversations, and stipulate that you must inform the person with whom you are speaking that the conversation is being recorded. Always obey the relevant laws and regulations of your country when using the recording feature of your Pocket PC Phone.

INTELLECTUAL PROPERTY RIGHT INFORMATION

Copyright © 2006 High Tech Computer Corp. All rights reserved.

    ExtUSB are trademarks and/or service marks of High Tech Computer Corp.

Microsoft, MS-DOS, Windows, Windows NT, Windows Server, Windows Mobile, ActiveSync, Excel, Internet Explorer, MSN, Hotmail, Outlook, PowerPoint, Word, and Windows Media are either registered trademarks or trademarks of Microsoft Corporation in the United States and/or other countries.

Bluetooth and the Bluetooth logo are trademarks owned by Bluetooth SIG, Inc.

microSD is a trademark of SD Card Association.

Java, J2ME and all other Java-based marks are trademarks or registered trademarks of Sun Microsystems, Inc. in the United States and other countries.

Copyright © 2006, Adobe Systems Incorporated.

Copyright © 2006, Macromedia Netherlands, B.V.

Macromedia, Flash, Macromedia Flash, Macromedia Flash Lite and Reader are trademarks and/or registered trademarks of Macromedia Netherlands, B.V. or Adobe Systems Incorporated.

Copyright © 2006, JATAAYU SOFTWARE (P) LTD. All Rights Reserved.

Copyright © 2006, Tao Group Limited. All Rights Reserved.

Copyright © 2006, Tegic Communications. T9 and XT9 are trademarks or registered trademarks of Tegic Communications. XT9 Mobile Interface is licensed under one or more of the following: U.S. Pat. Nos. 5,187,480, 5,818,437, 5,945,928, 5,953,541, 6,011,554, 6,286,064, 6,307,548, 6,307,549, and 6,636,162, 6,646,573, 6,970,599, 6,801,190, 7,030,863, 7,088,345; Australia Pat. Nos.

727539, 746674, 747901; Austria Pat. Nos. AT225534, AT221222; Brazil P.I. No. 9609807-4; Canada Pat. Nos. 1,331,057, 2,227,904, 2,278,549, 2,302,595; Japan Pat. Nos. 3532780, 3492981; United Kingdom Pat. No. 2238414B; Hong Kong Standard Pat. No. HK1010924; Republic of Singapore Pat. Nos. 51383, 66959, 71976, 89076; European Pat. Nos. 0 842 463 (96927260.8), 1 010 057 (98903671.0), 1 018 069 (98950708.2); Republic of Korea Pat. Nos. KR201211B1, KR226206B1, 402252, 552085; People's Republic of China Pat. No. ZL96196739.0; Mexico Pat. Nos. 208141, 216023, 218409; Russian Federation Pat. Nos. 2206118, 2214620, 2221268; New Zealand Pat. No. 519928; and additional patents are pending worldwide.

Licensed by QUALCOMM Incorporated under one or more of the following patents:

4,901,307	5,490,165	5,056,109	5,504,773	5,101,501	5,778,338	5,506,865
5,109,390	5,511,073	5,228,054	5,535,239	5,710,784	5,267,261	5,544,196
5,267,262	5,568,483	5,337,338	5,659,569	5,600,754	5,414,796	5,657,420
5,416,797						

ArcSoft MMS Composer™ Copyright © 2003-2006, ArcSoft, Inc. and its licensors. All Rights Reserved. ArcSoft & the ArcSoft logo are registered trademarks of ArcSoft, Inc. in the United States and/or other countries.

All other company, product and service names mentioned herein are trademarks, registered trademarks or service marks of their respective owners.

HTC shall not be liable for technical or editorial errors or omissions contained herein, nor for incidental or consequential damages resulting from furnishing this material. The information is provided "as is" without warranty of any kind and is subject to change without notice. HTC also reserves the right to revise the content of this document at any time without prior notice.

No part of this document may be reproduced or transmitted in any form or by any means, electronic or mechanical, including photocopying, recording or storing in a retrieval system, or translated into any language in any form without prior written permission of HTC.

Important Health Information and Safety Precautions

When using this product, the safety precautions below must be taken to avoid possible legal liabilities and damages.

Retain and follow all product safety and operating instructions. Observe all warnings in the operating instructions on the product.

To reduce the risk of bodily injury, electric shock, fire and damage to the equipment, observe the following precautions.

ELECTRICAL SAFETY

This product is intended for use when supplied with power from the designated battery or power supply unit. Other usage may be dangerous and will invalidate any approval given to this product.

SAFETY PRECAUTIONS FOR PROPER GROUNDING INSTALLATION

CAUTION – Connecting to an improperly grounded equipment can result in an electric shock to your device.

This product equipped with a USB Cable for connecting with desk-top or notebook computer. Be sure your computer is properly grounded (earthed) before connecting this product to the computer. The desk-top or notebook computer is equipped with a power supply cord having an equipment grounding conductor and a grounding plug. The plug must be plugged into an appropriate outlet which is properly installed and grounded in accordance with all local codes and ordinances.

SAFETY PRECAUTIONS FOR POWER SUPPLY UNIT

• Use the correct external power source

A product should be operated only from the type of power source indicated on the electrical ratings label. If you are not sure of the type of power source required, consult your authorized service provider or local power company. For a product that operates from battery power or other sources, refer to the operating instructions that are included with the product.

• Handle battery packs carefully

This product contains a Li-Ion or Li-Ion Polymer battery. There is a risk of fire and burns if the battery pack is handled improperly. Do not attempt to open or service the battery pack. Do not disassemble, crush, puncture, short external contacts or circuits, dispose of in fire or water, or expose a battery pack to temperatures higher than 60°C (140°F).

WARNING! Danger of explosion if battery is incorrectly replaced. To reduce risk of fire or burns, do not disassemble, crush, puncture, short external contacts, expose to temperature above 60°C (140°F), or dispose of in fire or water. Replace only with specified batteries. Recycle or dispose of used batteries according to the local regulations or reference guide supplied with your product.



SAFETY PRECAUTIONS FOR DIRECT SUNLIGHT

Keep this product away from excessive moisture and extreme temperatures. Do not leave the product or its battery inside a vehicle or in places where the temperature may exceed 60°C (140°F), such as on a car dashboard, window sill, or behind a glass that is exposed to direct sunlight or strong ultraviolet light for extended periods of time. This may damage the product, overheat the battery, or pose a risk to the vehicle.

SAFETY PRECAUTIONS OF HEARING LOSS

CAUTION –Permanent hearing loss may occur if earphones or headphones are used and prolonged listening at high volume.

SAFETY IN AIR CRAFTS

Due to the possible interference caused by this product to an aircraft's navigation system and its communications network, using this device's phone function on board an airplane is against the law in most countries. If you want to use this device when on board an aircraft, remember to turn off your phone by switching to Flight Mode.

ENVIRONMENT RESTRICTIONS

Do not use this product in gas stations, fuel depots, chemical plants or where blasting operations are in progress, or in potentially explosive atmospheres such as fuelling areas, fuel storehouses, below deck on boats, chemical plants, fuel or chemical transfer or storage facilities, and areas where the air contains chemicals or particles, such as grain, dust, or metal powders. Please be aware that sparks in such areas could cause an explosion or fire resulting in bodily injury or even death.

EXPLOSIVE ATMOSPHERES

When in any area with a potentially explosive atmosphere or where flammable materials exist, the product should be turned off and the user should obey all signs and instructions. Sparks in such areas could cause an explosion or fire resulting in bodily injury or even death. Users are advised not to use the equipment at refueling points such as service or gas stations, and are reminded of the need to observe restrictions on the use of radio equipment in fuel depots, chemical plants, or where blasting operations are in progress. Areas with a potentially explosive atmosphere are often, but not always, clearly marked. These include fueling areas, below deck on boats, fuel or chemical transfer or storage facilities, and areas where the air contains chemicals or particles, such as grain, dust, or metal powders.

ROAD SAFETY

Vehicle drivers in motion are not permitted to use telephony services with handheld devices, except in the case of emergency. In some countries, using hands-free devices as an alternative is allowed.

SAFETY PRECAUTIONS FOR RF EXPOSURE

- Avoid using your device near metal structures (for example, the steel frame of a building).
- Avoid using your device near strong electromagnetic sources, such as microwave ovens, sound speakers, TV and radio.
- Use only original manufacturer-approved accessories, or accessories that do not contain any metal.
- Use of non-original manufacturer-approved accessories may violate your local RF exposure guidelines and should be avoided.

INTERFERENCE WITH MEDICAL EQUIPMENT FUNCTIONS

This product may cause medical equipment to malfunction. The use of this device is forbidden in most hospitals and medical clinics.

If you use any other personal medical device, consult the manufacturer of your device to determine if it is adequately shielded from external RF energy. Your physician may be able to assist you in obtaining this information.

Turn the phone OFF in health care facilities when any regulations posted in these areas instruct you to do so. Hospitals or health care facilities may be using equipment that could be sensitive to external RF energy.

HEARING AIDS

Some digital wireless phones may interfere with some hearing aids. In the event of such interference, you may want to consult your service provider, or call the customer service line to discuss alternatives.

NONIONIZING RADIATION

This product should be operated in the suggested normal condition only to ensure the radiative performance and safety of the interference. As with other mobile radio transmitting equipment, users are advised that for satisfactory operation of the equipment and for the safety of personnel, it is recommended that no part of the human body be allowed to come too close to the antenna during operation of the equipment.

General Precautions

• Heed service markings

Except as explained elsewhere in the Operating or Service documentation, do not service any product yourself. Service needed on components inside the device should be done by an authorized service technician or provider.

• Damage requiring service

Unplug the product from the electrical outlet and refer servicing to an authorized service technician or provider under the following conditions:

- Liquid has been spilled or an object has fallen into the product.
- The product has been exposed to rain or water.
- The product has been dropped or damaged.
- There are noticeable signs of overheating.
- The product does not operate normally when you follow the operating instructions.

• Avoid hot areas

The product should be placed away from heat sources such as radiators, heat registers, stoves, or other products (including amplifiers) that produce heat.

• Avoid wet areas

Never use the product in a wet location.

• Avoid using your device after a dramatic change in temperature

When you move your device between environments with very different temperature and/or humidity ranges, condensation may form on or within the device. To avoid damaging the device, allow sufficient time for the moisture to evaporate before using the device.

NOTE When taking the device from low-temperature conditions into a warmer environment or from high-temperature conditions into a cooler environment, allow the device to acclimate to room temperature before turning on the power.

• Avoid pushing objects into product

Never push objects of any kind into cabinet slots or other openings in the product. Slots and openings are provided for ventilation. These openings must not be blocked or covered.

• Mounting Accessories

Do not use the product on an unstable table, cart, stand, tripod, or bracket. Any mounting of the product should follow the manufacturer's instructions, and should use a mounting accessory recommended by the manufacturer.

- **Avoid unstable mounting**

Do not place the product with an unstable base.

- **Use product with approved equipment**

This product should be used only with personal computers and options identified as suitable for use with your equipment.

- **Adjust the volume**

Turn down the volume before using headphones or other audio devices.

- **Cleaning**

Unplug the product from the wall outlet before cleaning. Do not use liquid cleaners or aerosol cleaners. Use a damp cloth for cleaning, but NEVER use water to clean the LCD screen.

Contents

Chapter 1	Getting Started	11
1.1	Getting to Know Your Phone and Its Accessories	12
1.2	Installing a Micro SD Card	15
1.3	The Home Screen	15
1.4	Status Indicators and Program Icons	16
1.5	Using the Start Menu.....	17
1.6	Using the Quick List	18
1.7	Entering Information.....	18
1.8	Battery Information.....	21
Chapter 2	Using Phone Features	23
2.1	Using the Phone.....	24
2.2	Making a Voice Call	24
2.3	Receiving a Voice Call	26
2.4	In-Call Options	26
2.5	Additional Dialing Information	27
Chapter 3	Synchronizing Information and Setting Up E-mail Security	29
3.1	About ActiveSync	30
3.2	Setting Up ActiveSync	30
3.3	Synchronizing Information.....	32
3.4	Synchronizing via Bluetooth	35
3.5	Synchronizing Music, Video, and Pictures	35
3.6	Setting Up E-mail Security	36
Chapter 4	Managing your Phone	39
4.1	Personalizing your Phone	40
4.2	Adding and Removing Programs	44
4.3	Using Task Manager and Managing Memory	45
4.4	Managing and Backing Up Files	46
4.5	Protecting your Phone	47
4.6	Restarting your Phone	48
4.7	Resetting your Phone	48

Chapter 5	Getting Connected	49
5.1	Connecting to the Internet	50
5.2	Using Internet Explorer Mobile	51
5.3	Using Internet Sharing	53
5.4	Using Comm Manager	54
5.5	Using Bluetooth	54
Chapter 6	Exchanging Messages and Using Outlook	61
6.1	Using E-mail and Text Messages	62
6.2	Using MMS Messages	67
6.3	Using Pocket MSN Messenger	71
6.4	Using Calendar	72
6.5	Using Contacts	73
6.6	Using Tasks	76
6.7	Using Voice Notes	77
Chapter 7	Experiencing Multimedia	79
7.1	Using Camera and Video Recorder	80
7.2	Using Pictures & Videos.....	85
7.3	Using Windows Media Player.....	88
7.4	Using Streaming Media	93
7.5	Using MIDlet Manager	94
Chapter 8	Using Other Applications	99
8.1	Using Doc Viewer	100
8.2	Using Speed Dial.....	103
8.3	Using Voice Speed Dial	104
Appendix		105
A.1	Regulatory Notices	106
A.2	PC Requirement to Run ActiveSync 4.x.....	110
A.3	Specifications.....	110
Index		113

Chapter 1

Getting Started

1.1 Getting to Know Your Phone and Its Accessories

1.2 Installing a Micro SD Card

1.3 The Home Screen

1.4 Status Indicators and Program Icons

1.5 Using the Start Menu

1.6 Using the Quick List

1.7 Entering Information

1.8 Battery Information

1.1 Getting to Know Your Phone and Its Accessories

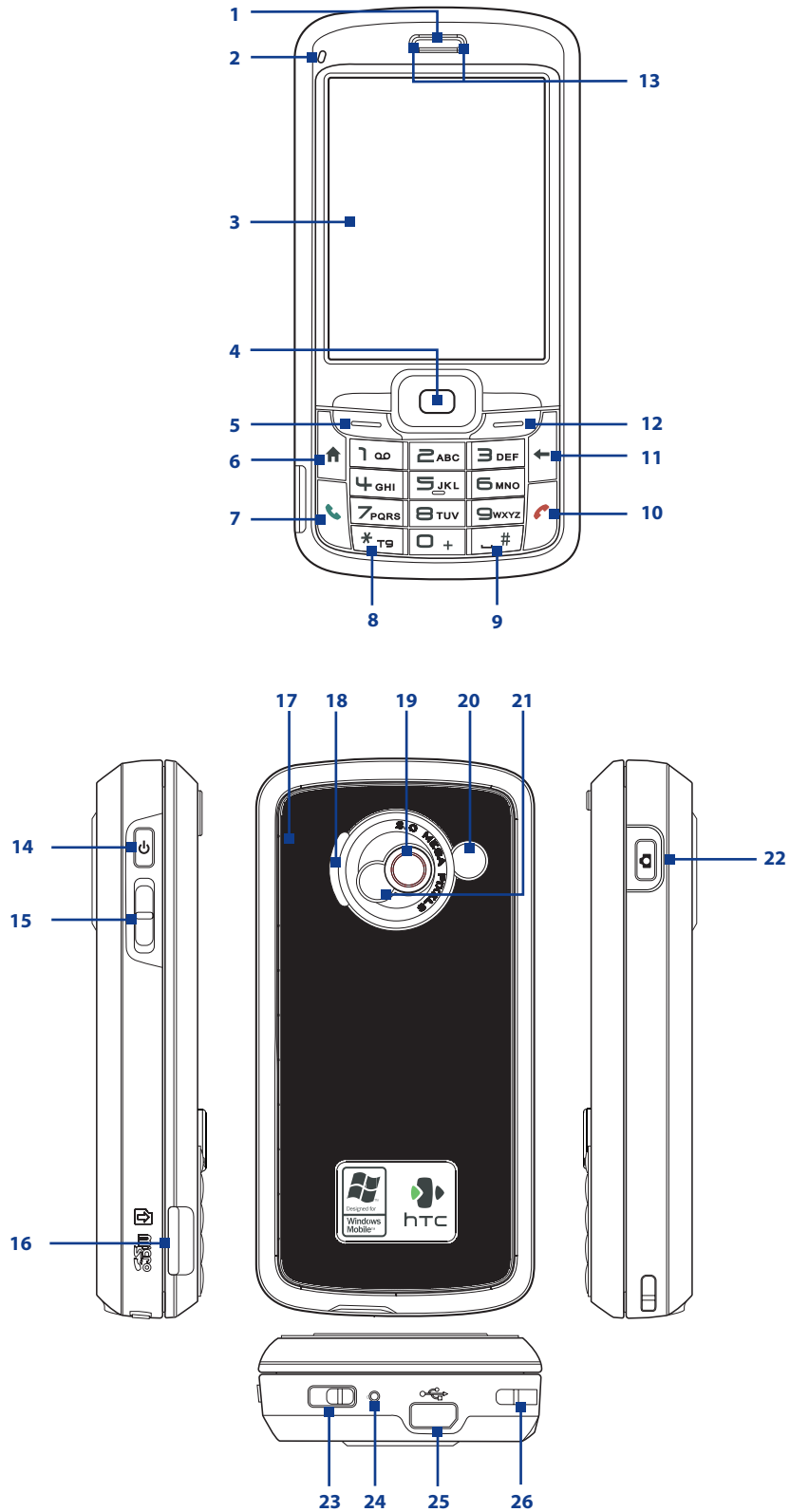

Item	Function
1. Speaker	Listen to phone call.
2. Light Sensor	Sense dark conditions and activate a backlight under the keypad and the QWERTY keyboard automatically, glowing in dark.
3. Display Screen	
4. NAVIGATION CONTROL/ENTER	Use to scroll left, right, up, or down. Press the center to use as the ENTER button..
5. Left SOFT KEY	Press to perform the command shown in the label above the button.
6. HOME	Press to go to the Home screen.
7. TALK	Press to dial a phone number or answer a call. Press and hold to activate/deactivate speakerphone mode.
8. * T9 Key	Press to change input modes or press and hold to choose an input mode or symbols from the list.
9. _ # Key	Press to add a space or press and hold to display a list of symbols.
10. END	Press to end a call, or press and hold to lock the phone keypad and the keyboard.
11. BACK	Press to go back to the previous screen, or backspace over characters.
12. Right SOFT KEY	Press to perform the command shown in the label above the button.
13. LED Indicators	The left LED indicator (green/red/amber) notifies you of the battery and network status of your phone, while the right LED indicator (blue) notifies you of Bluetooth connectivity status. For more information about LED Indicators, see the table at the end of this section.
14. POWER	Press to turn on (more than 1 second) and off the phone. Or press and quickly release the POWER button to display the Quick List, which allows you to change profiles, open Comm Manager, and enable/disable key lock and enable/disable device lock.
15. Volume Adjustment Slider	Slide this up or down to increase or decrease the earpiece volume during a call. Drag and hold the slider down to launch Voice Speed Dial and record voice tags.
16. microSD Slot	Insert a microSD memory card for storing data.
17. Back Cover	Remove to insert or replace battery.
18. Speaker	Listen to audio media or phone call when using speakerphone mode.
19. Camera lens	
20. Car Antenna Connector	Connect your phone to the car antenna while in a car to have better reception quality.
21. Self-Portrait Mirror	Turn the back side of your phone to face yourself so that your image reflects on the mirror when taking self-portrait shots.
22. CAMERA	Press to open the Camera program. If already running, press to capture an image or start recording a video clip.
23. Battery Cover Latch	Slide this latch to release the battery cover.
24. Microphone	Speak into the microphone when receiving or making a phone call or during voice recording.
25. Sync Connector/ Earphone Jack	Use for synchronizing data, recharging the battery, connecting the earphone to listen to audio media, or connecting the phone's hands-free kit.
26. Strap Holder	Attach a strap for carrying your device.

LED indicator lights

Various colors that might display in the two LED Indicators are summarized here.

Top LED	Status
Solid green	Battery is fully charged.
Blank	Battery case is empty or the phone is off.
Solid amber	Battery is charging or the phone is using ActiveSync to synchronize with a PC.
Solid red	Battery is not installed or battery is over-discharged.
Flashing green	Connected to the network.
Flashing red	Battery very low (less than 10%).
Flashing amber	Battery temperature is hotter or colder than the functional limits of 0 to 48 degrees Celsius (32 to 118 degrees Fahrenheit), and has stopped charging.
Amber/Green LED off	Battery fault. The "Battery Fault" indicator (⚠️) is displayed. In this case, the flashing green LED can be recovered by unplugging the AC adapter.
Bottom LED	Status
Flashing blue	Bluetooth mode set to "On" or "Visible" mode.

Accessories

The following accessories are provided with the phone:

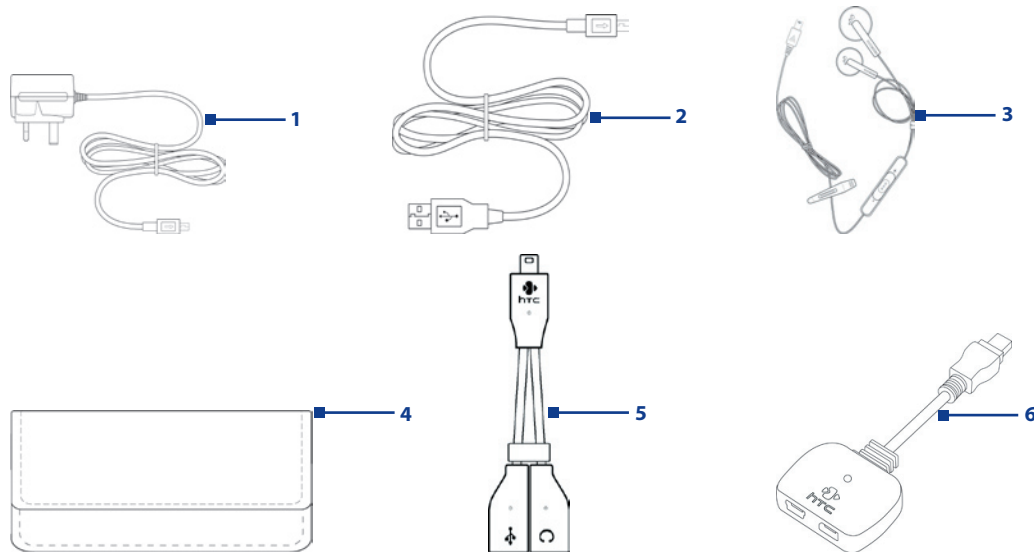

Accessory	Function
1. AC Adapter	Recharges the battery.
2. USB Sync Cable	Connects your device to a PC and synchronizes data.
3. Mini-USB Stereo Headset	Provides a volume control slider and a Send/End button. Press the Send/End button to pick up a call or put a call on hold; press and hold the button to end the call.
4. Pouch	Comes with belt clip. Store your device in the pouch to keep it away from dust and scratches..
5. One-to-two Y-Splitter Cable	Lets you connect the supplied AC adapter and a standard 2.5mm stereo headset to your device at the same time.
6. One-to-two Splitter Adapter	Lets you connect the supplied AC adapter and mini-USB stereo headset to your device at the same time.

1.2 Installing a Micro SD Card

You can install a Micro SD (Secure Digital) card in your phone to have an alternative storage place for your images, video, music, and other phone data.

To install the microSD card

- Insert the microSD card into the slot with its gold contacts facing up.
To remove, press the microSD card to pop it out of the slot.

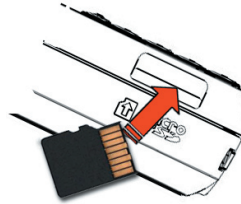

1.3 The Home Screen





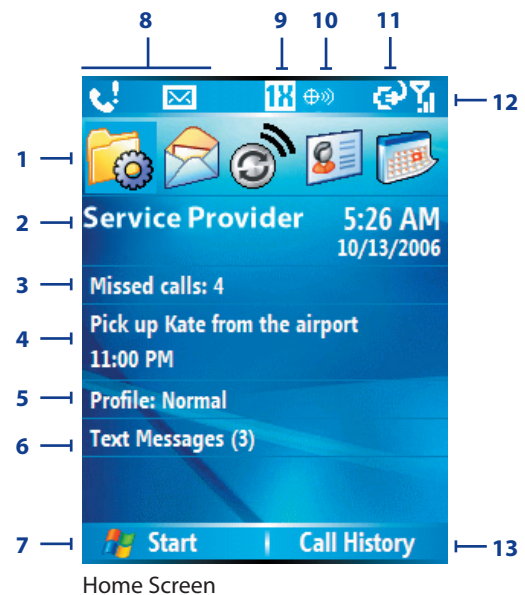

































The Home screen displays important information, such as upcoming appointments, status indicators, the current date, time, and profile, and icons of programs that you have recently used. You can open a program directly by selecting its icon and pressing ENTER.

- To access the Home screen from anywhere, press HOME.
 - To customize the Home screen display, including the background, click **Start > Settings > Home Screen**.
1. Select a recently-used program, and open it directly from the Home screen.
 2. Displays the name of your wireless service provider, date, and the time.
Click to open Comm Manager.
 3. Click to view the details of a missed call.
 4. Click to view the details of your next appointment.
 5. Displays the current Profile being used.
Click to change the current Profile.
 6. Displays the new messages that you have received.
Click to open the Messages folder.
 7. Click to display all program icons.
 8. Displays notifications, such as missed calls or new messages.
 9. Displays the available network or connectivity status.
 10. Displays the location settings.
 11. Displays the power status.
 12. Displays the network signal strength.
 13. Click to open Contacts, Call History, or Messages.

































1.4 Status Indicators and Program Icons

The following table lists common status indicators with their description.

Icon	Description	Icon	Description
	New e-mail or text message (SMS, Short Message Service)		1xRTT available (1xRTT, 1 times Radio Transmission Technology, is the third-generation data service)
	Roaming		1xRTT connected
	New MSN Messenger message		ActiveSync over 1xRTT in use
	Incoming voice call		EVDO available (EVDO, Evolution Data Optimized, is a high speed data service for wireless broadband and quick Internet access)
	Voice call in progress		EVDO connected
	Data call in progress		ActiveSync over EVDO in use
	Missed call		Lowercase text input
	Battery level		Uppercase text input
	Low battery		All Caps text input
	Very low battery		T9 text input mode, lowercase
	Battery charging		T9 text input mode, uppercase
	No battery or battery fault		T9 text input mode, caps lock
	Signal strength		Numeric input mode
	Radio connected or no signal		Ringer off
	Radio off		Speakerphone on
	Voice privacy currently unavailable		Vibrate call alert
	Voice privacy available and turned on		Location settings configured to broadcast your location only during a 911 call
	Sync error		Location settings configured to broadcast your location at all times
	Microphone muted		Bluetooth On or Visible mode

The following table lists icons of the programs that are already installed on your phone.

Icon	Program	Description
	ActiveSync	Synchronizes information between your phone and a PC.
	Adobe Reader LE	Enables you to view PDF (Portable Document Format) files on your phone.
	Calculator	Performs basic arithmetic and calculations, such as addition, subtraction, multiplication, and division.
	Calendar	Keeps track of your appointments, and creates meeting requests.
	Call History	Keeps track of all phone calls made, received, and missed.
	Camera	Captures photos in various modes.
	Clear Storage	Clears memory, restores the phone back to factory default settings, then restarts the phone.
	ClearVue Document	Lets you view Word documents on your phone.
	ClearVue Presentation	Lets you view PowerPoint files on your phone.
	ClearVue Worksheet	Lets you view Excel worksheets on your phone.
	Comm Manager	Lets you easily enable or disable your phone, start or stop synchronization with your computer, mute your phone, enable or disable Bluetooth, stop data services and enable or disable Direct Push.
	Contacts	Keeps track of contact information.

Icon	Program	Description
	Download Agent	Provides information about download status and the downloaded content from the Internet.
	File Explorer	Lets you organize and manage files and folders on your phone.
	Games	Lets you play two games: Bubble Breaker and Solitaire come with your phone.
	Internet Explorer	Allows you to browse Web and WAP sites, and to download new programs and files from the Internet.
	Internet Sharing	Lets your phone act as an external modem for your computer by using USB port or Bluetooth.
	Messaging	Lets you send and receive e-mails, MMS and text messages.
	MIDlet Manager	Lets you download and install Java-based applications, such as games and tools, on your phone.
	Pictures & Videos	Collects, organizes, and sorts media files in the My Pictures folder on your phone or on a storage card.
	Pocket MSN	Lets you send and receive instant messages with your MSN Messenger contacts.
	Settings	Personalize your phone to suit the way you use it.
	Speed Dial	Lets you create speed dial entries for dialing frequently-called phone numbers or for opening frequently-accessed programs.
	Streaming Media	Allows you to stream live or on-demand video.
	Task Manager	Keeps track of all programs currently running on your phone..
	Tasks	Keeps track of your tasks.
	Video Recorder	Captures video clips in various modes and duration.
	Voice Notes	Allows you to create short voice recordings.
	Voice Speed Dial	Lets you open a program or call a contact using voice recognition.
	Windows Media Player	Lets you play back video and audio files.

1.5 Using the Start Menu

The Start menu is located at the bottom-left corner of the Home screen and displays various program icons that are spread across one or more screens.

To see the available programs in the Start menu

On the Home screen, click **Start**. To see more programs, click **More** or use the NAVIGATION CONTROL.

Your phone comes with several bundled programs that you can start using immediately. You can also install additional programs from the included Windows Mobile® Getting Started Disc or from the Internet, or purchase mobile phone software from retail stores and install them on your phone.

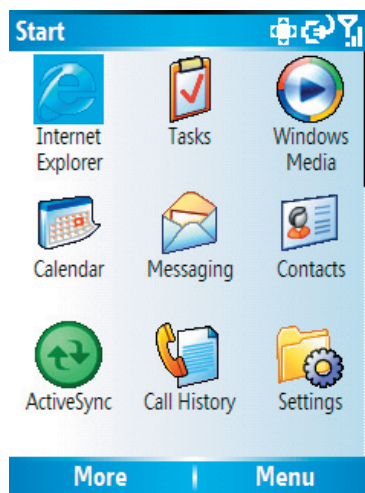

Start menu

1.6 Using the Quick List

The Quick List offers convenient access to a list of functions, such as locking your phone, and keyboard, opening Comm Manager, and choosing a different profile. For more information about profiles, see Chapter 4.

To access the Quick List

1. Briefly press (press and quickly release) the POWER button. Please note that pressing and holding the POWER button turns off the phone.
2. Scroll through the list and select the desired option. Then, do any of the following:
 - Click **Select**.
 - Press ENTER.
 - Press the corresponding number on the QWERTY keyboard.
3. To exit the Quick List at any time, click **Cancel**.

1.7 Entering Information

You can enter text, numbers, and symbols using the phone dialing keypad as well as from the sliding QWERTY keyboard. When you select a field that requires entering text or numbers, the phone automatically selects the appropriate input mode. The status indicator on the top-right corner of the display screen shows the input mode that you are currently using.

The phone supports three input modes for entering text and numbers: **Multipress**, **T9** and **Numeric**. Multipress and T9 modes are used for entering text, while Numeric mode is used for entering numbers.

abc	Multipress text input mode, lowercase
Abc	Multipress text input mode, uppercase
ABC	Multipress text input mode, caps lock
t9	T9 text input mode, lowercase
T9	T9 text input mode, uppercase
T9	T9 text input mode, caps lock
123	Numeric input mode

To change the input mode

1. Press and hold the * T9 key.
2. On the menu, click the input mode you want.

Use Multipress mode

In Multipress mode, you can enter a character by pressing the numeric key on which the character appears.

To enter text in Multipress mode

- To enter the first character on the numeric key, press once. To enter the second character on the numeric key, press twice and so on.
- To enter a character that is on the same numeric key, pause after you enter the first character.
- To enter punctuation, press the **1** key repeatedly until you see the punctuation you want.

To change the Multipress time out

You can change the length of time to pause between key presses on the same numeric key.

1. On the Home screen, click **Start > Settings > Accessibility**.
2. In **Multipress time out**, select the length of the pause between key presses.

Use T9 mode

To form a word in T9 mode, press the numeric keys on the phone keypad as well as on the QWERTY keyboard that contain the letters you want. As you enter letters, T9 analyzes your key presses and attempts to complete the word. For example, to enter the word "shoe", press 7, 4, 6, 3.

To enter text in T9 mode

1. Press and hold the * T9 key.
2. On the menu, click **T9 [Language]**.
3. Do any of the following:
 - Enter letters by pressing the keys on which the letters appear. Press a key only once for each letter. If there is more than one choice in the T9 dictionary for your entry, a list of available words is displayed.
 - Press the _ # key to enter a space after the word is entered, or click one of the available words and the space is added automatically.
 - If you do not see the desired word, click **Add Word?** from the list, and then enter the word using Multipress.
 - To enter punctuation, press the 1 key and select from a list of common punctuation marks.

Use Numeric mode

If a text box permits a numeric entry only, such as a phone number, the input mode automatically defaults to Numeric mode. However, if you need to enter numbers within a line of text, change to Numeric mode, and then change back to Multipress or T9 mode to finish entering the text.

To enter numbers in text boxes

1. Press and hold the * T9 key to change to Numeric mode.
2. On the keypad, enter the number or numbers you want.
3. Change back to Multipress or T9 input mode by pressing and holding the * T9 key, and then finish entering your text.

More text entry tasks

In both Multipress and T9 modes, the first letter of a sentence is by default capitalized.

To change between uppercase, lowercase and caps lock

- Press the * T9 key to change between uppercase, lowercase and caps lock within a text input mode.

To delete characters

- To backspace and delete a single character in any input mode, press BACK or Del (on the QWERTY keyboard).
- To backspace and delete an entire text or numeric field in any input mode, press and hold BACK or Del (on the QWERTY keyboard).

To enter a space

- In Multipress or T9 mode, press the * T9 key.

To enter a symbol

1. Press and hold the * T9 key.
2. On the menu, click **Symbols** to display the Symbol page.
3. Select the symbol you want and press ENTER.

To start a new line

In a multi-line text box, such as the notes area of a contact or a calendar appointment, do the following:

- In any input mode, press ENTER.

To enter the plus sign for international calls

- In a numeric entry box, press and hold 0.

Use the QWERTY keyboard

Your phone is equipped with a QWERTY keyboard, which is similar to a standard keyboard on your PC. To access this keyboard, slide the main screen leftward. This reveals the keyboard.

Note When you slide out the QWERTY keyboard, the display orientation automatically changes to landscape mode. Closing the keyboard automatically changes the orientation back to portrait mode.

The LED indicators corresponding to the **Cap** and **Fn** keys on the keyboard display solid amber color when the **Fn** and **Cap Shift** keys are pressed to turn on their functionality. Pressing a desired corresponding key after use turns them off. You can do the following with the QWERTY keyboard.

- To type lowercase letters, press the keys using your thumbs or fingers.
- To type all uppercase letters, press **Fn** first, and then press **Cap Shift**. To turn off this function, press **Fn** first, and then press **Cap Shift** again.
- To type a single uppercase letter, press **Cap Shift** and then press the corresponding key.
- To enter a number or symbol (labeled in red color) or to carry out a command like scrolling a page, press **Fn** and then press the corresponding key.
- To remain in the scrolling mode or to continue entering numbers or symbols (labeled in red color), press **Fn** twice and then press the corresponding keys.
- Press the left or right SOFT KEY to perform the command shown in the label above the key.
- To enter a symbol, press **Fn** and then press **Sym N**.
- To move or scroll through one page at a time, press **PgUp** or **PgDn**.
- To launch Messaging, press **M**, while for Internet Explorer, press **I**.

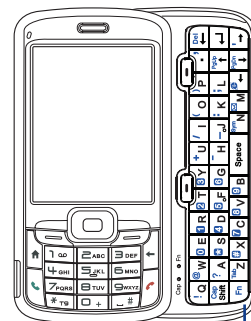

LED indicators for **Cap** and **Fn** keys

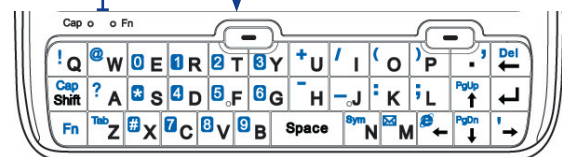

1.8 Battery Information

Battery performance depends on many factors, including your wireless service provider's network configuration, signal strength, the temperature of the environment in which you operate your phone, the features and/or settings you select and use, items attached to your phone's connecting ports, and your voice, data, and other program usage patterns.

Battery life estimates (approximations):

- Talk time: Up to 5 hours
- Standby time: Up to 200 hours
- Playing WMV: Up to 8 hours
- Playing WMA: Up to 12 hours

WARNING! To reduce risk of fire or burns:

- Do not attempt to open, disassemble, or service the battery pack.
- Do not crush, puncture, short external contacts, or dispose of in fire or water.
- Do not expose to temperatures above 60°C (140°F).
- Replace only with the battery pack designated for this product.
- Recycle or dispose of used battery as stipulated by local regulation.

To check the battery power

- On the Home screen, click **Start > Settings > Power Management**.

To optimize the power performance

- On the Home screen, click **Start > Settings > Power Management**, and adjust the backlight, display, and light sensor settings.

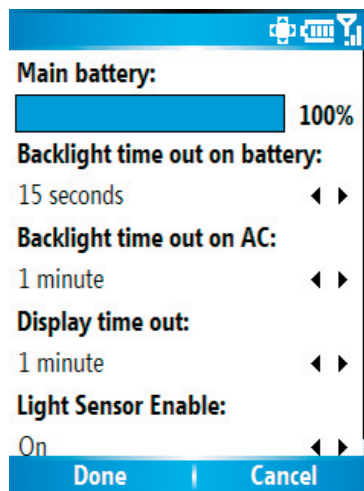

To manage a low battery

When the low-battery warning appears, do the following:

1. Immediately save your current data.
2. Synchronize with your PC to charge the battery.
3. Turn off your phone.

Note If you turn off the Phone function when you are out of your network coverage area, the phone automatically goes to the power-save mode and displays the following message:

Power-Saved Mode

Press any number key to exit

In this mode, your phone conserves the battery power. To quit this mode, press any number key on the keypad.

To charge the battery

New batteries are shipped partially charged. Before you start using your phone, it is recommended that you install and charge the battery. Some batteries perform best after several full charge/discharge cycles.

You can charge the battery in two ways:

- Connecting your phone directly to an external power source with the AC adapter.
- Connecting your phone to a PC via the provided USB Sync cable or Splitter cable/adapter.

WARNING!

- Do not remove the battery from the phone while you are charging it using the AC adapter.
- As a safety precaution, the battery stops charging when it overheats.

Chapter 2

Using Phone Features

2.1 Using the Phone

2.2 Making a Voice Call

2.3 Receiving a Voice Call

2.4 In-Call Options

2.5 Additional Dialing Information

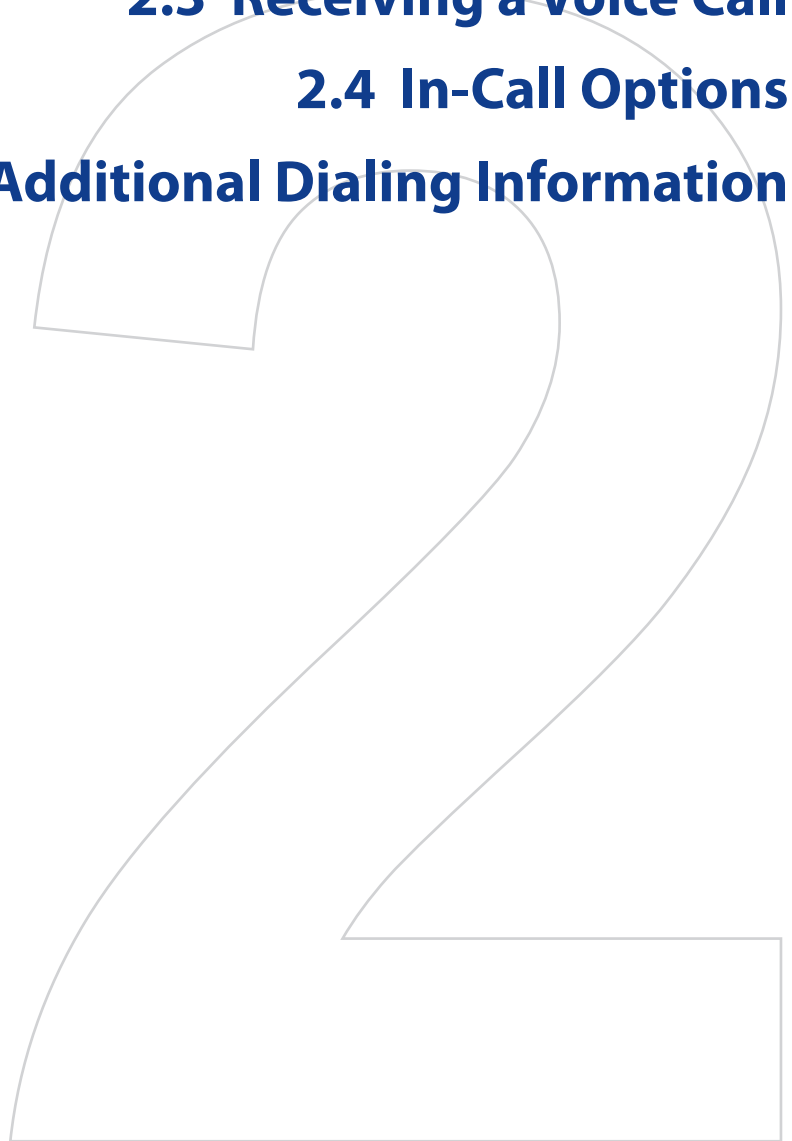

2.1 Using the Phone

You can use your phone to make, receive, and keep track of voice calls, and send text messages (SMS, Short Message Service) and MMS (Multimedia Messaging Service) messages. You can also dial a phone number directly from Contacts.

Access the Phone screen

From the Phone screen, you can open, call, or find a contact, and even save a new number in Contacts. To access the Phone screen, do any of the following:

- Press TALK ().
- Directly enter the phone number by pressing numeric keys on the phone keypad or the QWERTY keyboard.

Set ring tones

You can choose how to be notified for incoming calls, reminders, new messages, alarms, and more.

To set a ring tone for incoming calls

1. On the Home screen, click **Start > Settings > Sounds**.
2. In the Ring tone list, select a ring tone.
3. Click **Done**.

If you select **Vibrate**, the sound is muted and the phone will vibrate when you receive a call. The Vibrate icon () appears in the title bar. Selecting **None** in the Ring tone list mutes the phone. For more information about sounds, see “Choose how to be notified about events or actions” in Chapter 4.

Note To adjust the earpiece volume during a call, use the volume adjustment slider on the phone's side panel. Adjusting the volume at any other time can affect the ring, notification and MP3 sound levels.

2.2 Making a Voice Call

With your phone, you can make calls from the Home screen, the Phone screen, from Contacts, Speed Dial, or Call History.

Make a call from the Home screen

- Enter the phone number by pressing keys on the phone keypad or the QWERTY keyboard, and press TALK ().
- Press the BACK button or Del key if you need to backspace.

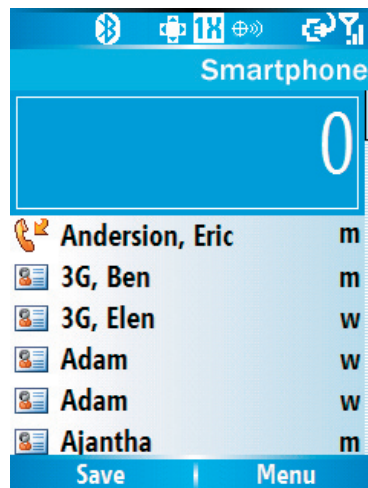

Phone screen

Tip You will notice that when you press a key on the phone keypad or the QWERTY keyboard, a list of names and numbers is displayed as your phone searches Contacts, Call History, and Speed Dial entries to find a matching name or number. When you see the number or name of the person you want to call, select it, and press TALK (📞).

Make a call from Contacts

1. On the Home screen, click **Start > Contacts**.
2. Select the desired contact, and press TALK (📞).

You can also select the desired contact in the contact list, and press the ENTER button twice (once to view the contact details, and once to dial the associated number).

To specify the number to dial

By default, the mobile telephone number (m) of a contact is dialed when you make a call from Contacts; however, you can choose to dial a different phone number.

1. On the Home screen, click **Start > Contacts**.
2. Select the contact.
3. Press NAVIGATION left or right. The letter representing the number changes to m (mobile), w (work), or h (home).

You can also select a contact in the contact list, and press ENTER to view details and different numbers associated with the contact. Select a number and press TALK (📞) or press ENTER to dial the number.

- You may also access the contact list by clicking **Contacts** on the Home Screen.
- To view or edit information associated with the selected contact, click **Menu > Edit**.

Make a call from Call History

1. On the Home screen, click **Start > Call History**.
2. Select a name or number, and press TALK (📞).

In the Call History screen, press ENTER to view details, such as the dialed, missed, or received call, call duration, date, and time. Pressing ENTER again dials the associated number.

To customize calls

You can select various options on the Call History screen to customize and filter the calls made, received, or missed.

- To find a name or number in Contacts, click **Menu > Find Contact**.
- To send a text message, click **Menu > Send Text Message**.
- To send an e-mail, click **Menu > E-mail**.
- To find the duration of a call, click **Menu > View Timers**.
- To remove a call or number from Call History, click **Menu > Delete**.
- To remove the list of calls or numbers from **Call History**, click **Menu > Delete List**.
- To save a name or number in Contacts, click **Menu > Save to Contacts**.
- To categorize the call or number into various call types, click **Menu > Filter**.

Note You can also save a number in Contacts by clicking **Save** on the Call History screen.

Make a call from Speed Dial

You can make calls using Speed Dial. To learn how to use Speed Dial, see “Using Speed Dial” in Chapter 8.

2.3 Receiving a Voice Call

When you receive a phone call, you have the option to answer it or ignore it.

To answer or ignore an incoming call

- To answer the call, click **Answer**, or press TALK (📞).
- To ignore the call, click **Ignore**, or press END (📞).

To end a call

- Press END (📞).

2.4 In-Call Options

Your phone provides various options for managing calls. During a call, you can use the loudspeaker mode, mute or unmute your voice, or access Contacts, Calendar, and Call History for reference.

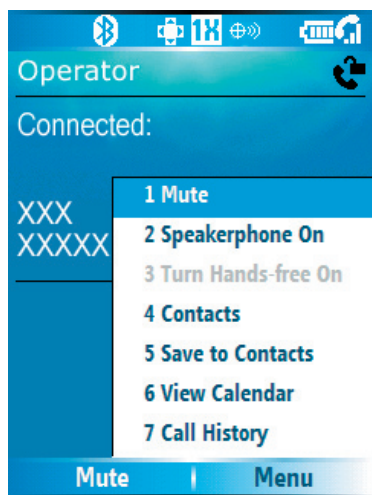

In-Call options

To turn the speakerphone on and off

The built-in speakerphone allows you to talk hands-free or lets other people listen to the conversation.

- During a call, click **Menu > Speakerphone On**. The 📞 icon appears at the top of the screen.
- To turn off the Speakerphone during the call, click **Menu > Speakerphone Off**. Alternatively, the speakerphone can be toggled on and off by pressing and holding TALK during the call.

WARNING! To avoid damage to your hearing, do not hold your phone against your ear when the Speakerphone is turned on.

To mute a call

You can turn off the microphone during a call, so that you can hear the caller but the caller cannot hear you.

- During a call, click **Menu > Mute**.





When the microphone is turned off, the 📞 icon appears on the screen. Click **Menu > Unmute** to turn on the microphone again.

2.5 Additional Dialing Information

Make an emergency call

- Enter the appropriate emergency number for your locale, and press TALK ().

Make an international call

1. Press and hold  on the phone keypad until the  sign appears. The  replaces the international prefix of the country that you are calling.
2. Enter the full phone number, and press TALK (). The full phone number includes country code, area code (without the leading zero, if any), and phone number.

Insert a pause in a dialing sequence

Some international calls require a pause in the dialing sequence in order for the call to process successfully.

1. On the Home screen, click **Start > Contacts**.
2. Select the contact entry that contains the phone number in which you want to insert a pause, and press ENTER to open the contact card.
3. Click **Menu > Edit**.
4. Position the cursor on the phone number where you want to insert a pause.
5. Click **Menu > Insert Pause**.
The letter “p” will appear in the number to indicate where the pause will occur in the dialing sequence.
6. Click **Done**.

Insert a longer pause in a dialing sequence

Some phone numbers may require a longer pause than the default pause in the dialing sequence. In these cases, you can pause as long as you want, and manually continue the dialing sequence.

1. On the Home screen, click **Start > Contacts**.
2. Select the contact entry that contains the phone number in which you want to insert a longer pause, and press ENTER to open the contact card.
3. Click **Menu > Edit**.
4. Position the cursor on the phone number where you want to insert a longer pause.
5. Click **Menu > Insert Wait**.
The letter “w” will appear in the number to indicate where the longer pause (wait) will occur in the dialing sequence.
6. Click **Done**.

Note When you call a number that contains a longer pause, you must press TALK () again to continue dialing.

Chapter 3

Synchronizing Information and Setting Up E-mail Security

3.1 About ActiveSync

3.2 Setting Up ActiveSync

3.3 Synchronizing Information

3.4 Synchronizing via Bluetooth

3.5 Synchronizing Music, Video, and Pictures

3.6 Setting Up E-mail Security

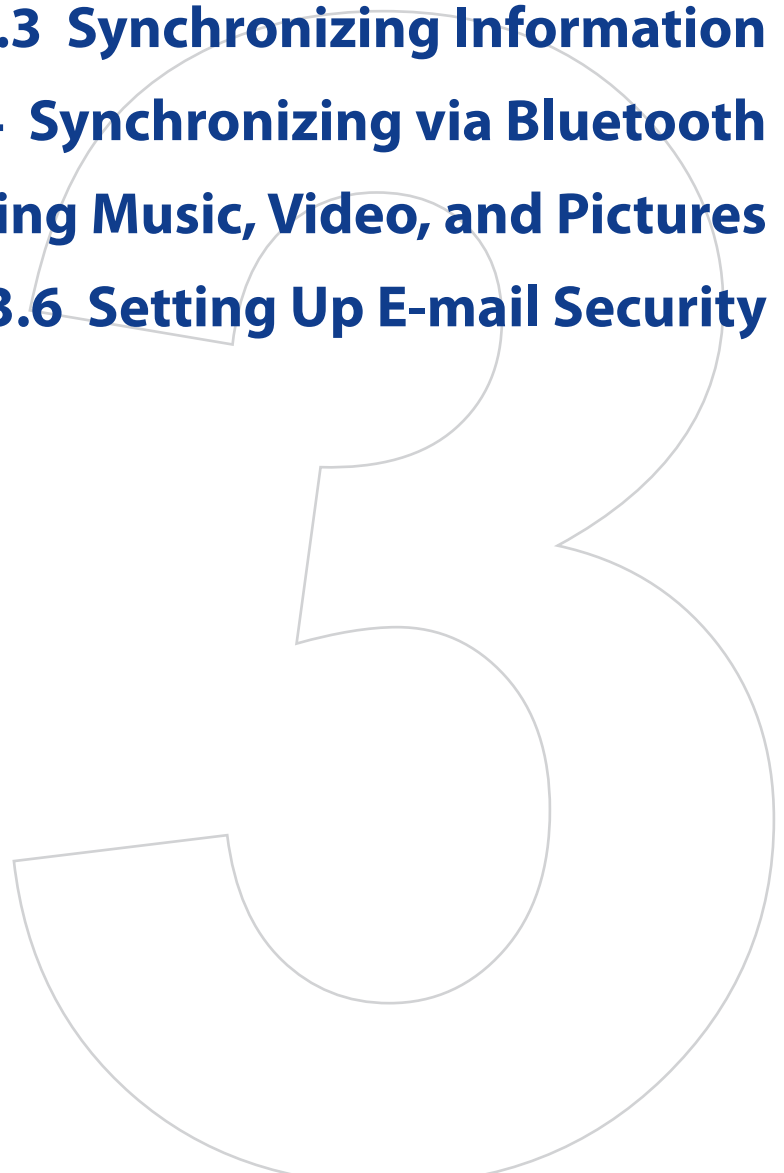

3.1 About ActiveSync

ActiveSync synchronizes information on your phone with information on your PC such as Outlook content. ActiveSync can also synchronize over a wireless or cellular network with Exchange Server if your company or service provider is running Exchange Server with Exchange ActiveSync.

Specifically, you can use ActiveSync to:

- Synchronize information, such as Outlook e-mail, contacts, calendar, or tasks information on your phone with your PC, as well as pictures, video, and music.
- Synchronize Outlook e-mail, contacts, calendar appointments, and tasks on your phone directly with Exchange Server so that you can stay up to date even when your PC is turned off.
- Copy files between your phone and your PC.
- Select which types of information are synchronized and specify how much information is synchronized. For example, you can choose how many weeks of past calendar appointments to synchronize.
- Add and remove programs on your phone. For details, see Chapter 4, “Adding and Removing Programs.”

3.2 Setting Up ActiveSync

To install and set up ActiveSync on the computer

1. Install ActiveSync on your PC, as described on the Windows Mobile® Getting Started Disc.
2. After Setup completes, the Synchronization Setup Wizard automatically starts when you connect your phone to the PC. The wizard will guide you to create a synchronization relationship between your phone and computer. Click **Next**.
3. Do not select the **Synchronize directly with a server running Microsoft Exchange Server** check box if you will synchronize your phone with a computer. Just click **Next**, then skip to step 8.
4. If you will synchronize your phone with Exchange Server, select the **Synchronize directly with a server running Microsoft Exchange Server** check box, then click **Next**.
5. On the Exchange server credentials screen, enter the Exchange server address, your user name and password, and the domain name.

If you do not know what the Exchange server address and domain name are, you can check with your network administrator, or you can check them in your computer by doing the following:

- a. In Outlook, click **Tools > E-mail Accounts**.
- b. Select **View or change existing e-mail accounts**.
- c. Double-click **Microsoft Exchange Server**.
- d. On the Exchange Server Settings screen, you will see the Exchange Server name.

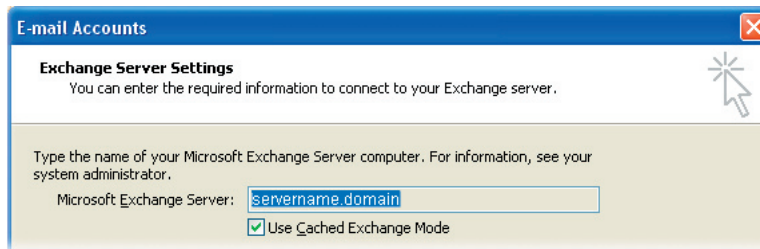

- e. To check the domain name, click **Start > Settings > Control Panel**, then double-click **System**.
- f. In the System Properties dialog box, click the **Computer Name** tab. You will then see the domain name.

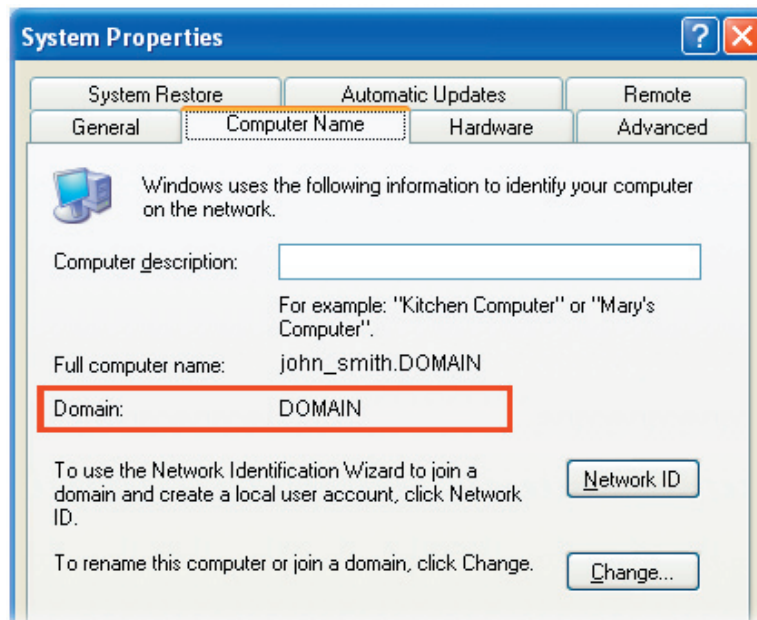

6. On your phone, you also need to enter the Exchange server settings. For information about this, see "Synchronizing directly with Exchange Server."
7. On the Synchronization Setup Wizard, click **Next**.
8. Select the information types to synchronize between your phone and computer.

If you will synchronize your phone with both your computer and Exchange Server, do the following:

- For the Contacts, Calendar, E-mail, and Tasks items, choose whether to synchronize them with the computer or with the Exchange Server. These items cannot be synchronized to both.
- Select the check boxes of the other information types if you want to synchronize them with your computer.

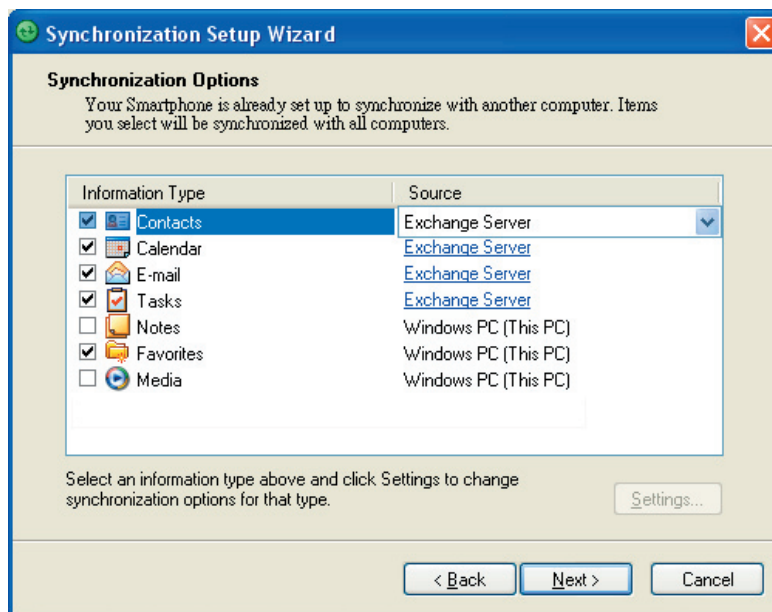

Information types on the PC and Exchange Server

9. Click **Next**.

10. Click **Finish**.

When you finish the wizard, ActiveSync synchronizes your phone automatically. Once synchronization completes, you can disconnect your phone from your PC.

3.3 Synchronizing Information

When you connect your phone to the PC, ActiveSync will immediately synchronize. While the phone is connected, ActiveSync synchronizes every time you make a change on either the PC or the phone.

To manually start and stop synchronization

1. Connect your phone.

- To synchronize local information on the PC, such as Outlook information or media files, connect your phone to the PC using Bluetooth or a cable.
- If you are synchronizing directly with Exchange Server, you can use the connection to the PC to access the network, or you can synchronize over a cellular or wireless network without connecting to the PC.

2. In ActiveSync, click **Sync**. To end synchronization before it completes, click **Stop**.

Note ActiveSync 4.x utilizes a network type of connection with Windows Mobile powered devices, since this allows faster data transfer than a serial USB connection. When the PC is connected to the Internet or a local network, in some cases, the PC may disconnect the ActiveSync connection with your device in favor of the Internet or network connection. If this happens, click **Start > Settings > Connections > USB to PC**, then clear the **Enable advanced network functionality** check box. This makes ActiveSync utilize a serial USB connection with your device.

Synchronize Outlook information with the computer

If you have set up a synchronization relationship between your phone and the PC, synchronization keeps Outlook information up-to-date on both of them.

You can also set up your phone to synchronize with more than one PC, or with a combination of one or more PCs and Exchange Server. When synchronizing with multiple computers, the items you synchronize will appear on all of the computers with which they are synchronized. For example, if you have set up

synchronization with two PCs (PC1 and PC2), which have different items, and you synchronize Contacts and Calendar on the phone with both computers, the result is as follows:

Location	New state
PC1	All Outlook contacts and calendar appointments that were on PC2 are now also on PC1.
PC2	All Outlook contacts and calendar appointments that were on PC1 are now also on PC2.
Phone	All Outlook contacts and calendar appointments from both PC1 and PC2 are on the phone.

Note Outlook e-mail can be synchronized with only one computer.

To change which information is synchronized

ActiveSync synchronizes a limited amount of information by default to save storage space on your phone. You can change the amount of information that is synchronized by performing the following steps.

Note Before changing synchronization settings on the phone, disconnect it from your PC.

1. On the Home screen, click **Start > ActiveSync**.
2. In ActiveSync, click **Menu > Options**.
3. Do one or more of the following:
 - Select the check box for the items you want to synchronize. If you cannot select a check box, you might have to clear the check box for the same information type elsewhere in the list.
 - Clear the check box for any items you want to exclude.
 - To customize synchronization of a computer, select the computer name then click **Menu > Settings**.
 - To customize synchronization of a particular information, select the information type then click **Settings**.
 - To stop synchronizing with one computer completely, select the computer name and click **Menu > Delete**.

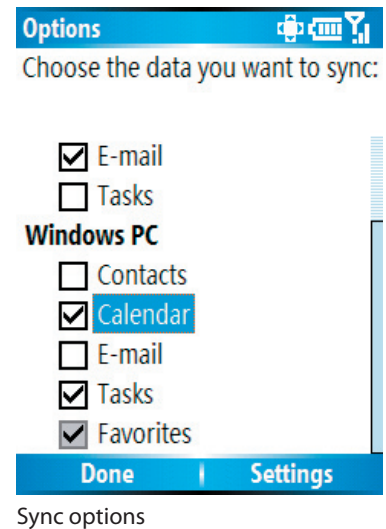

Note Outlook e-mail can be synchronized with only one computer.

Synchronize Outlook information with Exchange Server

You can set up synchronization with Exchange Server on your phone, if it is available to you through your company or wireless service provider. However, you should first ask your administrator or check your computer for the following information and then carry on with the steps: Exchange Server name, domain name, your user name, and password. (For information about how to check the Exchange server name and domain on your PC, see "To install and set up ActiveSync on the computer.")

Note Before changing synchronization settings on the phone, disconnect it from your PC.

To synchronize directly with Exchange Server

1. Do one of the following:
 - Click **Start > Messaging > New Account**. On the E-mail Setup screen, select Outlook E-mail in the **Your e-mail provider list**, then click **Next**.
 - In ActiveSync on your phone, click **Menu > Configure Server**. If you have not yet set up synchronization with Exchange Server, this appears as **Add Server Source**.
2. On the Edit Server Settings screen, enter the name of the server running Exchange Server in the **Server address** box, and click **Next**.
3. On the User Information screen, enter your user name, password, and domain name.
4. If you want the phone to save your password so that you need not to enter it again when connecting, select the **Save password** check box. Then, click **Next**.

5. On the Options screen, select the check boxes of the types of information that you want to synchronize with the Exchange Server.
6. To customize synchronization of a particular information, select the type of information then click **Menu > Settings**.

Note Settings is not available for Contacts and Tasks.

7. To change the rules for resolving synchronization conflicts, click **Menu > Advanced** on the Options screen.
8. Click **Finish**.

Note You can also use the Sync Setup Wizard to set up the phone to synchronize remotely with the Exchange Server. This wizard is started when you connect your phone to your PC after installing ActiveSync on the PC.

Schedule synchronization with Exchange Server



You can schedule information to be synchronized automatically between your phone and the Exchange Server, or schedule synchronization at regular time intervals. Choose between these two methods, depending on your e-mail volume and which method you think is more cost-effective.

To receive e-mails and synchronize other information instantly

The **Direct Push** technology (Push E-Mail feature) enables you to receive new e-mails on your phone as soon as they arrive in your Inbox on the Exchange Server. With this feature, items, such as contacts, calendar and tasks are also immediately updated onto your phone when these items have been changed or new entries have been added on the Exchange Server. To make Direct Push work, your phone is set up with a high performance over-the-air network connection, such as 1xRTT or EVDO. For more information about these connections, contact your network service provider.

The Direct Push feature works for your phone if your private network such as your corporate network is using Microsoft Exchange Server Service Pack 2 (SP2) with Exchange ActiveSync, and after your first full synchronization with the Exchange Server.

Using Comm Manager

1. Click **Start > Comm Manager**.
2. In the Comm Manager screen, click the **Microsoft Direct Push** button. The button  will turn to , this indicates that you will receive e-mails as they arrive. When the button is in the  state, you need to manually retrieve your e-mails.

Using ActiveSync

1. In ActiveSync on your phone, click **Menu > Schedule**.
2. Select **As items arrive** in the **Peak times** and **Off-peak times** boxes.

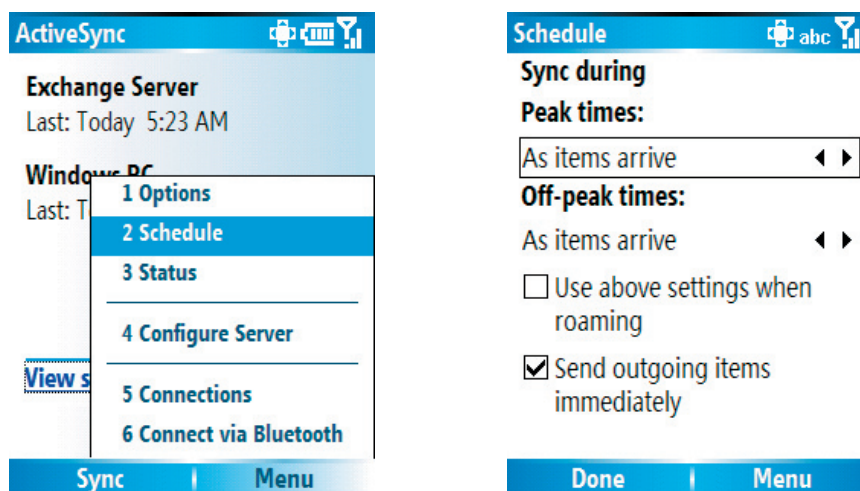

To schedule synchronization at regular time intervals

You can set how often to synchronize during **Peak times** (which usually refer to your working hours) when e-mail volume is high, as well as **Off-peak times** when e-mail volume is low.

1. In ActiveSync on your phone, click **Menu > Schedule**.
2. On the Schedule screen, select a shorter time interval in the **Peak times** box for you to be able to receive e-mails more frequently.
3. Select a longer interval in the **Off-peak times** box.

Tip To set the days and hours that make up your peak and off-peak times, click **Menu > Peak Times** on the Schedule screen.

3.4 Synchronizing via Bluetooth

You can connect your phone to the PC to synchronize using the local wireless technology, Bluetooth.

To synchronize with a PC via Bluetooth

1. Follow the instructions in ActiveSync Help on the PC for configuring Bluetooth on your PC to support ActiveSync.
2. On the Home screen, click **Start > ActiveSync**.
3. Click **Menu > Connect via Bluetooth**. Ensure that the phone and the PC are within close range.
4. If this is the first time you have connected to this PC via Bluetooth, you must complete the Bluetooth wizard on the phone and set up a Bluetooth partnership with the PC before synchronizing.
5. Click **Sync**.
6. When finished, click **Menu > Disconnect Bluetooth**.

Notes

- To preserve battery power, turn off Bluetooth when not in use.
- To connect and synchronize your phone with a computer via Bluetooth, your computer must have a Bluetooth adapter or dongle.

3.5 Synchronizing Music, Video, and Pictures

If you want to take your music or other digital media with you, ActiveSync works with Windows Media Player to synchronize music, video, and pictures with your phone.

Other than selecting the media information type in ActiveSync to be synchronized, all media synchronization settings must be set in Windows Media Player. Before media can be synchronized, you must do the following:

- Install Windows Media Player Version 10 or later on the PC.
- Connect your phone to the PC with a USB cable. If the phone is currently connected using Bluetooth, you must end that connection before media can be synchronized.
- Insert a 32MB or larger storage card into your phone.
- Set up a sync partnership between the storage card and Windows Media Player.

Change Media synchronization settings

Once you select the Media information type in ActiveSync to be synchronized, any of your favorite music, video, and picture files in Windows Media Player playlists can be synchronized by ActiveSync. All you have to do is set up synchronization in Windows Media Player for those media files.

To set up a sync relationship with a storage card

1. On the PC, open Windows Media Player.
2. Click the **Sync** tab.
3. Select the storage card.
4. Click **Set up Sync**.
5. Choose whether to synchronize automatically or manually.

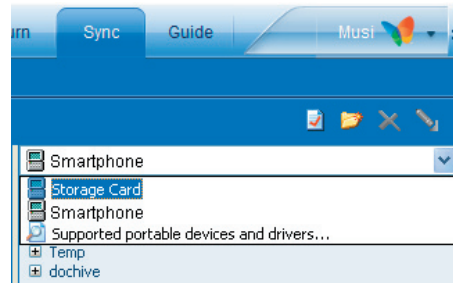

For information about using Windows Media Player on the phone, see “Using Windows Media Player” in Chapter 7.

3.6 Setting Up E-mail Security

Windows Mobile on your phone protects your Outlook e-mails through Secure/Multipurpose Internet Mail Extension (S/MIME), which allows you to digitally sign your messages as well as encrypt them.

Using authorization keys and certificates, S/MIME allows you to digitally sign your e-mail messages to prove your identity to the recipients. Authorization keys are also used when encrypting messages to improve privacy and prevent undue tampering or hacking of your messages. You can encrypt a message with or without a certificate. However, to read an encrypted message, you need a valid certificate for decrypting e-mail messages.

Note S/MIME encryption and digital signatures for Windows Mobile-based devices are available only with Exchange Server 2003 Service Pack 2 or a later version that supports S/MIME. If you are not using one of these products, or have not yet synchronized, these options are unavailable.

Digitally sign and encrypt all messages

ActiveSync allows you to set up S/MIME e-mail encryption and signing. You will have to obtain a valid certificate for signing or encrypting e-mail before you will be able to sign or encrypt mail successfully.

1. On the Home screen, click **Start > ActiveSync**.
2. Click **Menu > Options**.
3. Select the **E-mail** information type, and click **Settings**. On the E-mail Sync screen, click **Menu > Advanced**.

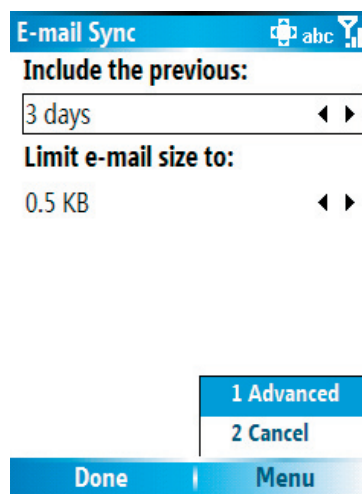
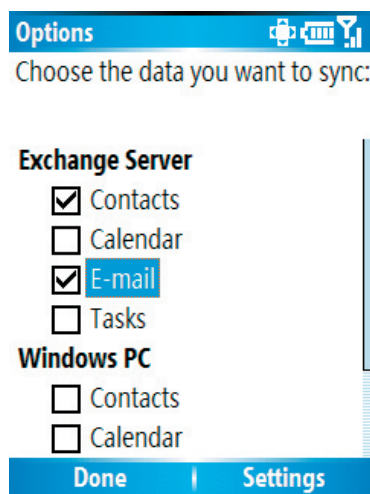

4. Do one or both of the following:
 - To sign all your outgoing e-mail messages so that recipients can be certain that the messages were sent by you and have not been altered in any way, select **Sign messages**.
 - To encrypt all your outgoing e-mail messages so that the contents of your messages are protected from being viewed by anyone other than the intended recipients, select **Encrypt messages**.
5. Click **Menu > Choose Certificate** to select a certificate for signing or encrypting outgoing e-mail messages.

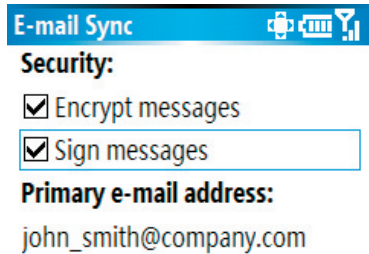

You can select certificates to sign or encrypt e-mail messages individually if you do not choose to sign or encrypt all outgoing e-mails. For information about signing and encrypting individual messages, see “Individually sign and encrypt a message” in Chapter 6.

Chapter 4

Managing your Phone

4.1 Personalizing your Phone

4.2 Adding and Removing Programs

4.3 Using Task Manager and Managing Memory

4.4 Managing and Backing Up Files

4.5 Protecting your Phone

4.6 Restarting your Phone

4.7 Resetting your Phone

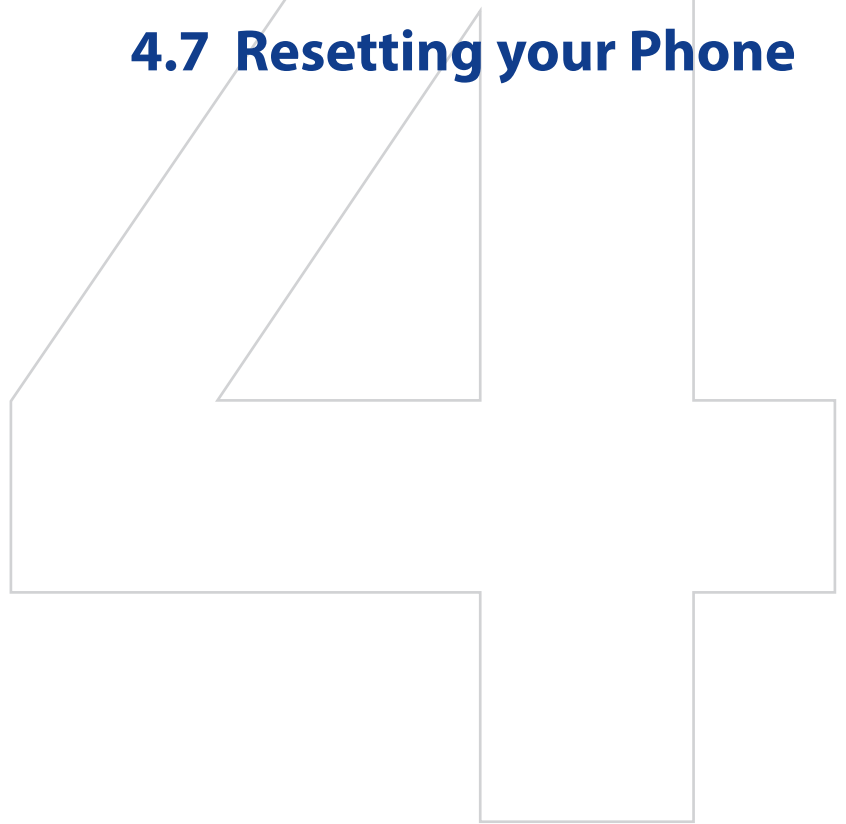

4.1 Personalizing your Phone

Set up the Home screen

The Home screen is your starting place for most tasks. You can gain access to all features and programs from the Home screen.

The top of the Home screen displays icons for the programs that you have most recently used. The center of the Home screen can display your next appointment, the number of new messages (voice mail, text, e-mail, or MMS) that you have received, and other important information. When you click an icon or item on the Home Screen, the associated program opens.

To customize the Home screen

1. On the Home screen, click **Start > Settings > Home Screen**.
2. In **Home screen layout**, **Color scheme**, **Background image**, and **Time out**, select the options you want, and click **Done**.

To set a picture as the background

1. On the Home screen, click **Start > Pictures & Videos**.
2. Select the picture you want to set as the background. Click **View** or press ENTER for a larger view of the image.
3. Click **Menu > Use as Home Screen**.
4. Use NAVIGATION to select the portion of the picture you want to use, and click **Next**. If the picture fits the screen, this step is skipped.
5. In **Adjust the transparency**, select a higher percentage for a more transparent picture or a lower percentage for a more opaque picture.
6. Click **Finish**.

Set date, time, language, and other regional options

Your phone should already be set up with the regional settings that are appropriate for your locale.

To change regional settings

You can specify the language, locale, date and time style, as well as number and currency formatting options.

1. On the Home screen, click **Start > Settings > Regional Settings**.
2. In **Language**, select your preferred language.
3. In **Locale**, select the locale for the language you selected. The **Locale** option automatically changes the format of the remaining options (such as date, time, and currency) according to the locale you specify.
4. Click **Done**.

Note You must turn your phone off and on again for the changes to take effect.

To set the date and time

1. On the Home screen, click **Start > Settings > Clock & Alarm > Date and Time**.
2. In **Time zone**, select your time zone.
3. In **Date**, edit the month, day, or year.
4. In **Time**, edit the hour, minute, and second.
5. Click **Done**.

Choose how to be notified about events or actions

A profile is a group of settings that determine how your phone will alert you to incoming calls and events, such as e-mail receipt notifications, alarms, or system events. A number of different preset combinations of these settings are included with your phone. Each profile appears with a descriptive name.

To change the current profile

1. On the Home screen, click **Profile: [Type]**. For example, **Profile: Normal**.
2. Choose a new profile, and click **Done**.

Tip To quickly change the profile, press and hold **POWER** to display the Quick List, and choose a profile. You can also change the profile by clicking **Settings > Profiles** from the Comm Manager screen.

To edit a profile

1. On the Home screen, click **Profile: [Type]**. For example, **Profile: Normal**.
2. Select the profile to edit.
3. Click **Menu > Edit**.
4. Do one of the following:
 - Modify the settings, and click **Done**.
 - To cancel without saving changes, click **Cancel**.

Tip To revert to the default profile settings, click **Menu > Reset to default**.

To specify the sound for an event

1. On the Home screen, click **Start > Settings > Sounds**.
2. For the desired event, select a sound. Select **None** if you do not want to hear a sound.
3. Click **Done**.

Note For ring tones, you can use sounds in either .wav, .mid, .wma, or .mp3 file format. For notifications or reminders, you can use .wav or .mid files.

Tip When you select a sound, the sound plays. To hear it again, select **Menu > Play**.

To set sound for the keyboard

1. On the Home screen, click **Start > Settings > Sounds**.
2. In **Keypad control**, select a sound. Select **None** if you do not want to hear any sound while pressing a key.
3. Click **Done**.

To display digital clock on Unlock message screen

You have the option to choose whether you want to view the current date and time while you unlock the phone.

1. On the Home screen, click **Start > Settings > Unlock Screen Clock**.
2. Select the desired option for date and time, and click **Done**.

To copy a sound to your phone

After a sound file is located on your phone, you can use it for a ring tone, notification, or reminder. Sound files in either .wav, .mid, .wma, or .MP3 formats can be used.

1. Connect the phone to your PC using a USB connection.
2. On your PC, copy the sound file you want.

3. In ActiveSync on your PC, click **Explore** and double-click **My Windows Mobile-Based Device**.
4. Do one of the following:
 - To save the sound file on your phone, double-click **Application Data**, double-click **Sounds**, and paste the file into that folder.
 - To save the sound file on your storage card, double-click **Storage Card**, and paste the file into the folder you want.

To set an alarm

1. On the Home screen, click **Start > Settings > Clock & Alarm > Alarm**.
2. In **Alarm**, choose one of the following:
 - **Off** to turn the alarm off.
 - **On** to turn the alarm on.
3. In **Alarm time**, enter the time for the alarm to go off.
4. Click **Done**.

Set personal information

Entering and displaying owner information are best practices; they allow someone to return the phone to you in case it is lost.

To enter owner information

1. On the Home screen, click **Start > Settings > Owner Information**.
2. Complete the following:
 - In **Name**, enter your name.
 - In **Telephone number**, enter a number where you can be reached.
 - In **E-mail address**, enter your e-mail address.
 - In **Notes**, enter any other information you want to include.
3. Click **Done**.

Set performance and maintenance options

To change accessibility settings

1. On the Home screen, click **Start > Settings > Accessibility**.
2. Select your preference for the following:
 - In **System font size**, set the size of the font that is displayed on the screen.
 - In **Multipress time out**, set the length of time between keypresses when entering text in Multipress mode.
 - In **Confirmation time out**, set the delay before an unconfirmed action times out.
 - In **In-call alert volume**, set the volume for incoming call or receiving new message alerts while you are in a call.
3. Click **Done**.

To change power management settings

You can use Power Management to check the battery, and configure settings that prolong battery life.

1. On the Home screen, click **Start > Settings > Power Management**.
2. Adjust the following:
 - In **Backlight time out on battery**, select the amount of time for the phone to be idle before the backlight turns off.
 - In **Backlight time out on AC**, select the amount of time for the phone to be idle before the backlight turns off when using AC power.
 - In **Display time out**, select the time limit for the phone to be idle before the screen turns off.
3. Click **Done**.

Tip **Main battery** indicates the amount of battery life remaining.

To find the operating system version number

- On the Home screen, click **Start > Settings > About**.
The operating system version number installed on your phone along with the manufacturer copyright information will be listed on the screen.

To find the phone specification

- On the Home screen, click **Start > Settings > System Information**.
The System Information screen displays the details about the phone specification, such as processor, speed, memory, display, model name, and so on.



To turn on and off error reporting

1. On the Home screen, click **Start > Settings > Error Reporting**.
2. Do one of the following:
 - Select **Enable** to turn on error reporting.
 - Select **Disable** to turn off error reporting.
3. Click **Done**.

Use phone settings and services

You can customize and set various options for an incoming or outgoing call on your phone, such as voice privacy, location, and more. You can also choose to activate and use optional phone services on your phone. Contact your wireless service provider first to ask about the availability of these services before you use them.

The following are some of the optional phone services that can be used on your phone:

Phone Settings and Services	Use
Call Options	Provide options for setting any key answer to incoming calls, notifying when voice privacy is unavailable, and setting your phone number, voice mail number, country code, and area code.
Location Setting	Allow the mobile phone network to detect your current location via your device's built-in GPS chip. This is especially useful in times of emergency. At the top right of the Phone screen and Home screen, one of these icons appears:  - when the LOCATION ON option is selected  - when the 911 ONLY option is selected
Mode Preference	Provide options to select a connection mode for your phone. While there are options to choose between 1x-Only and EVDO-Only , it is recommended that you select Automatic to let your phone choose the connection mode on its own.

Phone Settings and Services	Use
NAM Select	Number Assignment Module (NAM) is a memory location on your device where programmed phone numbers are stored. Your service provider may store up to two numbers on your device: NAM 1 which stores your phone number, and NAM 2 which stores a different phone number for roaming. You can manually select one of these numbers, or you can select the Auto-NAM option to make your device automatically switch to one of the programmed numbers when it detects the appropriate network signal.
Network Service	Choose to accept roaming (by selecting one of these options: Automatic-A or Automatic-B . Otherwise restrict your device to phone calls from your home network only (by selecting the Home only option).
TTY Mode	Allow the use of a TTY (teletypewriter) device with the phone for users who are visually or hearing impaired.
Voice Privacy	Protect conversations from possible eavesdropping, especially when you are roaming. This prevents devices such as scanners to pick up your frequency.

To enable optional phone services

1. Click **Start > Settings > Phone**.
2. Select the service you want to use and press ENTER.
3. Select desired options for the service and click **Done**.

Note You can also access the Phone settings by clicking **Settings > Phone** on the Comm Manager screen.

To turn voice privacy on or off

1. Click **Start > Settings > Phone > Voice Privacy**.
2. Press ENTER to select the desired option, and click **Done**.

Either  or  appears on the upper right area of the Phone screen during a call based on whether voice privacy has been enabled or disabled.

4.2 Adding and Removing Programs

Before you purchase additional programs for your phone, you should note the name of your phone, the version of Windows Mobile software running on it, and the type of processor. This information will help you select a program that is compatible with your phone. For more information, see “To find the operating system version number” in this chapter.

Programs available for purchase usually include a Setup program (commonly named “setup.exe”) that you must first install on your PC. You can then use ActiveSync to add programs to your phone or add a program directly from the Internet.

To add programs

1. Download the program to your PC (or insert the disc that contains the program into the CD drive of your PC). You may see a single *.exe file, a *.zip file, a Setup.exe file, or several versions of files for different device types and processors. Be sure to select a program designed for your phone and processor type.
2. Read any installation instructions or documentation that comes with the program. Many programs provide special installation instructions.
3. Connect your phone and PC.
4. Double-click the *.exe file.
 - If the executable file is an installation wizard, follow the instructions on the screen. Once the program has been installed on your PC, the wizard will automatically transfer the program to your phone.

- If an installation wizard does not start, you will see an error message stating that the program is valid but that it is designed for a different type of computer. You will need to copy this program to your phone. If you cannot find any installation instructions for the program, use ActiveSync to copy the program file to the Program Files folder on your phone.

To remove a program

Programs that come with the phone cannot be removed.

1. On the Home screen, click **Start > Settings > Remove Programs**.
2. Scroll to the program to remove.
3. Click **Menu > Remove**.

4.3 Using Task Manager and Managing Memory

To see how much memory is available

1. On the Home screen, click **Start > Settings > About**.
2. Scroll down to **Available Memory**.

Use Task Manager

Task Manager allows you to view all the programs currently running on your phone in the form of a list. From Task Manager, you can switch to, activate, or terminate any currently running program. It also allows you to view the phone's memory status.

To start Task Manager

- Click **Start > Task Manager**.

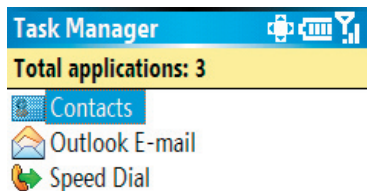

Task Manager

The Task Manager Menu contains the following options.

Option	Allows you to
Go To	Switch to the selected program.
Refresh	Refresh the Task Manager screen to reflect a list of currently running programs.
Stop	Stop the selected program. You can view the free memory status at the bottom of the screen.
Stop All	Stop all listed programs. Click OK to confirm that you want to end all currently running programs. You can view the free memory status at the bottom of the screen.
Stop All But Selected	Stop all running programs in the list except the one you selected.
System Info	View information about power status, memory usage, flash, and phone information.
About	View program name, version, and copyright information.

4.4 Managing and Backing Up Files

You can back up files to your PC using ActiveSync or copy files to a storage card that is installed by you on your phone. You can also efficiently manage your files and folders using File Explorer installed on your phone.

Using Microsoft ActiveSync, you can copy or move information from the PC to the phone and vice versa. Changes you make to the information on one computer will not affect the information on the other computer. If you want to automatically update information on both your phone and PC, synchronize the information instead. For more information about copying and synchronizing files, see ActiveSync Help on your PC.

To copy a file using ActiveSync

Copying a file results in separate versions of a file on your phone and PC. Because the files are not synchronized, changes made to one file will not affect the other.

1. Connect your phone to your PC.
2. In ActiveSync, click **Explore**, which opens the Mobile Device folder for your phone.
3. In the Mobile Device folder, go to the file that you want to copy on your phone or PC.
4. Do one of the following:
 - To copy the file to your phone, right-click the file, and click **Copy**. Right-click the desired folder on your phone, and click **Paste**.
 - To copy the file to your PC, right-click the file and click **Copy**. Right-click the desired folder on your PC, and click **Paste**.

Use File Explorer

File Explorer provides many easy-to-use features for file and folder management.

To start File Explorer

- On the Home screen, click **Start > File Explorer**.

File Explorer operates in the following two views:

- List View
- Icons View

File Explorer displays the entire file structure in your phone's memory. The functions focus primarily on folder management. When initially started, File Explorer is in List View by default. To switch between views, click **Menu > View > Icons** or **List**.

The File Explorer menu contains the following options:

Option	Allows you to
Send	Lets you send the selected file through one of the messaging features.
Beam	Lets you send the selected file through Bluetooth .
Edit	Opens a menu where you can choose to cut, copy, paste, delete or rename a file. You can also create a new folder.
Properties	View information about the selected folder or file.
View	Opens a menu where you can switch between the Icons or List view.
Sort By	Opens a menu where you can choose to sort the files or folders by Name, Date, Size or Type.
My Device	Displays the folders and files in the root folder of the phone.
My Documents	Displays the folders and files in the My Documents folder.

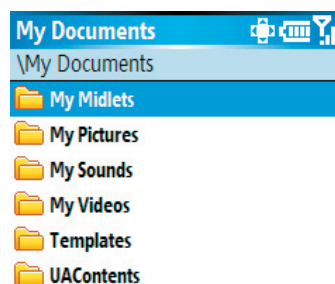

File Explorer - List View

To send a file as an e-mail attachment

1. In File Explorer, select a file.
2. Click **Menu > Send**.
3. On the Messaging screen, select **Outlook E-mail** or a custom e-mail account.
4. The file will automatically be attached to the new message.
Specify the recipient and subject, and type your message.
5. Click **Send**.

4.5 Protecting your Phone

You can protect your phone from unauthorized use by requiring a type of password called a simple PIN (personal identification number) or a strong alphanumeric password.

To lock the keypad

Locking the keypad turns off keypad functionality. This is a helpful feature if, for example, the phone is turned on and in your pocket, and you want to prevent accidental keypresses. Locking keypad also locks the QWERTY keyboard.

- On the Home screen, press and hold HOME.
Once the keypad is locked, the left soft key label changes to **Unlock**.

Tip To quickly lock the keypad, select **Key lock** from the Quick List.

Note You can still receive calls and make emergency calls when the keypad is locked.

To unlock the keypad

- On the Home screen, click **Unlock** and press the * key.

To enable the phone lock

1. On the Home screen, click **Start > Settings > Security > Device lock**.
2. Select **Prompt if device unused for** then select the amount of time for the phone to be inactive before automatically locking.
3. Select the **Password type** then enter and confirm your password.
4. Click **Done**.

Notes

- Alternatively, select **Device lock** from the Quick List to configure the phone lock settings.
- Once you configure the phone lock settings, you can enable the phone lock from the Quick List directly without configuring the settings again.

To disable the phone lock

- Click **Unlock** then enter the password you have set to unlock your phone.

4.6 Restarting your Phone

Occasionally, you may want to restart your phone, for example, when a program is not performing properly or the phone is not responding to any keypresses.

To restart the phone

1. Remove the battery.
2. Reinsert the battery and turn on your phone.

WARNING! If the phone is restarted while a program is running, any unsaved work will be lost.

4.7 Resetting your Phone

Resetting your phone will remove all the data from its memory which include contacts, tasks, calendar appointments, and more, and restore the phone back to the factory default settings.

WARNING! All your data will be deleted, it is recommended that you back up your data first before resetting your phone.

To reset your phone

1. Click **Start > Accessories > Clear Storage**.
2. Follow the on-screen instructions to reset the phone.

The phone will restart after it has been reset.

Chapter 5

Getting Connected

- 5.1 Connecting to the Internet**
- 5.2 Using Internet Explorer Mobile**
- 5.3 Using Internet Sharing**
- 5.4 Using Comm Manager**
- 5.5 Using Bluetooth**

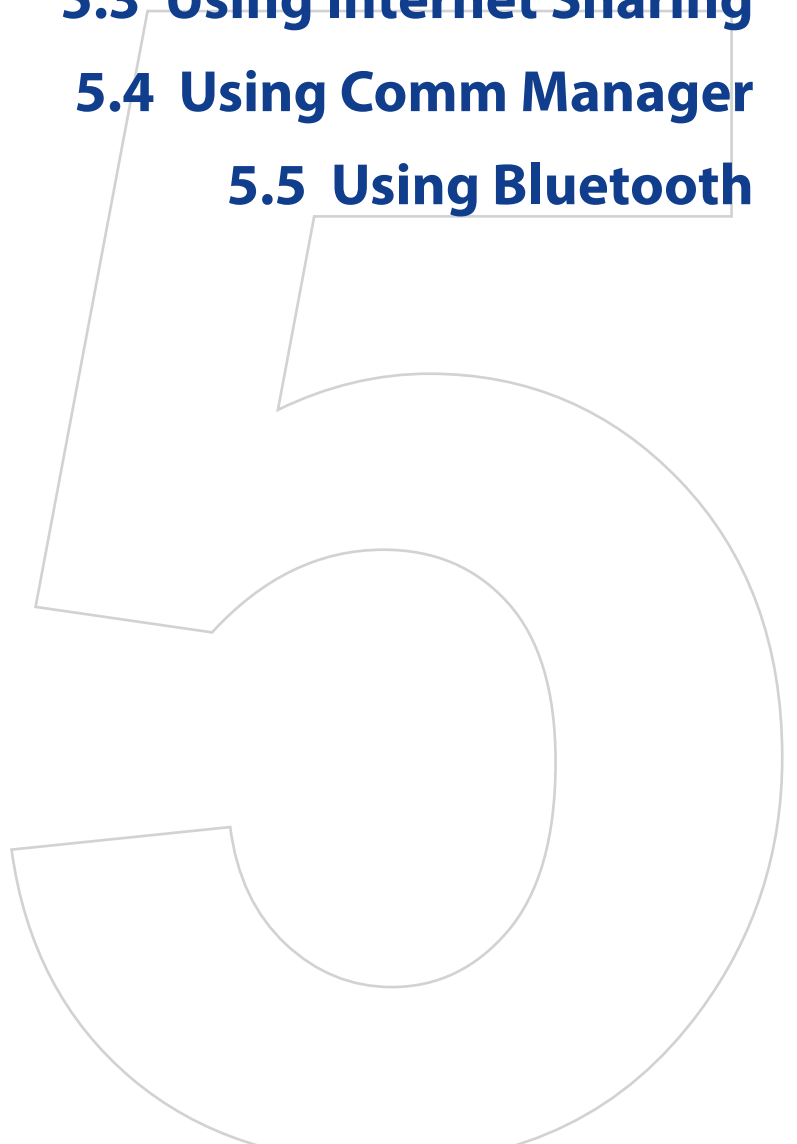

5.1 Connecting to the Internet

Your phone's powerful networking capabilities allow you to access the Internet or your corporate network at work through wireless and conventional connections. Specifically, you can configure your phone to establish a connection via Dial-up, Bluetooth, Virtual Private Network (VPN), or Proxy.

With an active connection on your phone, you can browse the Web, download e-mails, or chat using Pocket MSN. Check with your service provider to see if a connection has already been set up for you, and if over-the-air configuration is supported.

If you need to manually set up a connection, it is important that you obtain the following information from your Internet Service Provider (ISP) or the company whose intranet you are trying to access:

- ISP server phone number
- User name
- Password
- Domain name (required for accessing a corporate network or an intranet)

Set up a Dial-up connection

When you use your phone to dial up to your ISP and connect to the Internet or to your corporate network, you will be billed by the number of minutes that you use.

However, there are some high speed and high performance data connection services (such as 1xRTT and 1xEVDO) available on your phone. While 1xRTT (1 times Radio Transmission Technology) is a third-generation data service (equivalent to GPRS), 1xEVDO (1 times Evolution Data Optimized) is another high speed wireless broadband service (equivalent to UMTS) available on your phone for quick Internet access and Direct Push to work. For more information on how to avail these services, contact your network service provider.

To establish a dial-up connection on your phone, you need the same settings that you normally use when you dial up from your computer. This includes the ISP server phone number, your user name, and password.

To set up a dial-up connection for browsing the Internet

1. On the Home screen, click **Start > Settings > Connections > Dial-up**.
2. Click **Menu > Add**.
3. In **Description**, enter a name for the connection.
4. In **Connects to**, select **The Internet**.
5. Enter the appropriate information in the remaining fields.

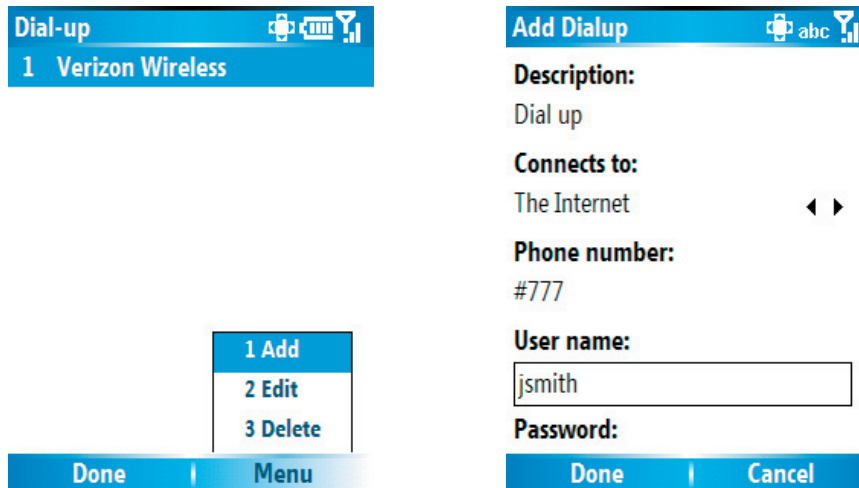

6. Click **Done**. To start browsing the Internet, click **Start > Internet Explorer**.

To set up a dial-up connection to your corporate network

1. On the Home screen, click **Start > Settings > Connections > Dial-up**.
2. Click **Menu > Add**.
3. In **Description**, enter a name for the connection.
4. In **Connects to**, select **Work**.
5. Enter the appropriate information in the remaining fields.
6. Click **Done**.

Note You can also add and set up the following connections:

- **VPN:** A VPN connection is used to access your corporate network by using an existing Internet connection.
- **Proxy:** A Proxy connection is used to access the Internet using an existing connection to your corporate or WAP network.

Advanced options

From the Connections screen, you can access advanced options to specify the service provider, the number of redial attempts, the amount of idle time to wait before disconnecting, and so on.

1. On the Home screen, click **Start > Settings > Connections**.
2. Click **Menu > Advanced**.
3. Select a network service provider for each connection type. You can choose **Automatic** to allow the phone to set a service provider for each connection by default.
4. Click **Menu > Options**.
5. Choose the appropriate information in the remaining fields.
6. Click **Done**.

Add a URL exception

Some URLs for Web pages on your company intranet may use periods, for example: intranet.companyname.com. To view these pages in Internet Explorer Mobile, you must create a URL exception.

1. On the Home screen, click **Start > Settings > Connections**.
2. Click **Menu > Advanced**.
3. Click **Menu > Work URL Exceptions**.
4. Click **Menu > Add**.
5. In **URL Pattern**, enter the URL name.
To add multiple URLs, use a semicolon (;).
6. Click **Done**.

Note You do not need to create URL exceptions for Internet URLs.

5.2 Using Internet Explorer Mobile

Internet Explorer Mobile is a full-featured Internet browser, optimized for use on your phone.

To open Internet Explorer

- On the Home screen, click **Start > Internet Explorer**.

Note You can also open Internet Explorer by pressing  and then  from the QWERTY keyboard.

To go to a link

1. While on a Web page, scroll vertically or horizontally to see all available links.
2. Click the link.

To go to a Web page

1. In Internet Explorer, click **Menu > Address Bar**.
2. Enter the address, and click **Go**.

To change Web page display options

1. While on a Web page, click **Menu > View**.
2. Select one of the following:
 - **One Column.** Arranges the content into one column that is as wide as the screen. This means that you will rarely have to scroll horizontally.
 - **Default.** Maintains a layout similar to what you see on a desktop computer, but makes items smaller and arranges the content so that you can see most of it without having to scroll horizontally.
 - **Desktop.** Keeps the same layout and size as on a desktop computer, which will require both horizontal and vertical scrolling.

To change the size of text on Web pages

- While on a Web page, click **Menu > Zoom** and select the size you want.

To show or hide pictures on Web pages

- While on a Web page, click **Menu > View > Show Pictures**.
A check mark next to **Show Pictures** indicates that pictures will be displayed on Web pages.

To view a page in full-screen mode

- While on a Web page, click **Menu > View > Full Screen**.

Tip To exit full-screen mode, press any of the SOFT KEYS, and then click **Menu > View > Full Screen** to cancel the selection.

To add a Web page to the Favorites list

1. To go to the page you want to add, click **Menu > Address Bar**, enter the address, and click **Go**.
2. Click **Menu > Add to Favorites**.
3. Confirm or change the name and Web page address.
4. In **Folder**, select a folder for the favorite.
5. Click **Add**.

Tip A quick way to add favorites to your phone is to synchronize with your PC using ActiveSync. For more information, see ActiveSync Help on your PC.

To view a favorite

1. While on a Web page, click **Favorites**.
2. Select a favorite, and click **Go**.

To move a favorite to a folder

1. Click **Favorites**.
2. Select the favorite to move.

3. Click **Menu** > **Edit**.
4. Under **Folder**, scroll to the folder to which you want to move the favorite.
5. Click **Done**.

To clear history, cookies, or temporary files

1. While on a Web page, click **Menu** > **Tools** > **Options**.
2. Click **Memory**.
3. Select the type of memory to clear.
4. Click **Clear**, click **Yes**, and then click **Done**.

To send a link via e-mail

1. Go to the desired Web page.
2. Click **Menu** > **Tools** > **Send Link via E-mail**.
3. Select **Text Messages** or **Outlook E-mail**.
4. A new message is created with the page address inserted in the message body.

5.3 Using Internet Sharing

With Internet Sharing, you can use your phone as an external modem for another device, such as a PDA or notebook computer.

- Notes**
- Make sure you have set up a phone dial-up modem connection on your phone. If your phone has not been set up with a data connection yet, click **Menu** > **Connection Settings** on the Internet Sharing screen. For more information about setting up a phone dial-up connection, see "Set up a dial-up connection".
 - If you want to use a USB cable connection, you must first install Microsoft ActiveSync version 4.2 or later on the computer.
 - Before using Internet Sharing, disable ActiveSync on your computer. To disable ActiveSync, open ActiveSync on your computer, then click **File** > **Connection Settings** and clear **Allow USB Connections**.

Set up the phone as a modem

To set up the phone as a USB modem

1. On your phone, click **Start** > **Internet Sharing**.
2. In the **PC Connection** list, select **USB**.
3. In the **Network Connection** list, select the name of connection that your phone uses to connect to the Internet.
4. Plug in the USB cable between your phone and the computer.
5. Click **Connect**.

To end the Internet connection

- On the Internet Sharing screen, click **Disconnect**.

To set up the phone as a Bluetooth modem

You can connect your phone to a computer through Bluetooth and use the phone as a modem for the computer. To learn how to set up the phone as a Bluetooth modem, see "Use the phone as a Bluetooth modem" in this chapter.

5.4 Using Comm Manager

Comm Manager acts like a central switcher that lets you enable or disable phone features as well as manage your data connections easily.

To open Comm Manager:

- Click **Start** > **Comm Manager**.

Simply click the corresponding button to enable or disable a feature.

1. Click to toggle between enabling or disabling the phone. Click **Settings** > **Phone** to manage Phone settings.
2. Click to toggle between turning on or off Bluetooth. See “Using Bluetooth” for details. Click **Settings** > **Bluetooth Settings** to configure Bluetooth on your phone.
3. Click to toggle between automatically receiving (as items arrive) or manually retrieving Outlook e-mails. For more information, see “To receive e-mails and synchronize other information instantly” in Chapter 3.
4. Click to stop active data services (e.g. ISP dial-up, 1xRTT, or 1xEVDO). You cannot reconnect data services in Comm Manager.
5. Click to toggle between turning on the phone’s ringer or setting it to vibration/mute mode. Click **Settings** > **Profiles** to edit a profile or customize notification settings.
6. Click to open ActiveSync so you can synchronize the phone and computer. For more information about the configuration settings for ActiveSync, see Chapter 3.



Comm Manager screen

Note You can also change the Phone settings and Profiles from the Comm Manager screen by clicking **Settings**.

5.5 Using Bluetooth

Bluetooth is a short-range wireless communications technology. Phones with Bluetooth capabilities can exchange information within a distance of about 10 meters without requiring a physical connection. You can even beam information to a device in a different room, as long as it is within the Bluetooth signal coverage range.

Bluetooth can be used in the following ways:

- Beam information, such as files, appointments, tasks, and contact cards, between devices that have Bluetooth capabilities.
- Synchronize information between your phone and computer via Bluetooth.
- Use a Bluetooth-enabled headset with your phone for hands-free phone conversations. A Bluetooth stereo headset can also be used for listening to music.
- Use a Bluetooth service. Once you connect your phone to another device or computer using Bluetooth, you can locate and use any of the services available on that device.
- Use your phone as a Bluetooth modem for a computer.

Bluetooth modes

Bluetooth on your phone operates in three different modes:

1. **On.** Bluetooth is turned on. Your phone can detect other Bluetooth-enabled devices, but not vice versa.
2. **Off.** Bluetooth is turned off. In this mode, you can neither send nor receive information using Bluetooth. You might want to turn off the radio at times to conserve battery power, or in situations where radio use is prohibited, such as onboard an aircraft and in hospitals.
3. **Visible.** Bluetooth is turned on, and all other Bluetooth-enabled devices within range can detect your phone.

Note By default, Bluetooth is turned off. If you turn it on, and then turn off your phone, Bluetooth also turns off. When you turn on your phone again, Bluetooth automatically turns on.

To turn on or off Bluetooth on your phone

You can enable Bluetooth by clicking the On/Off switch in Comm Manager. You can also do the following:

1. On the Home screen, click **Start > Settings > Connections > Bluetooth**.
2. In **Bluetooth**, select **On**.
3. Click **Done**.

To turn off Bluetooth capabilities on your phone, in **Bluetooth**, select **Off**.

To make your phone visible

1. On the Home screen, click **Start > Settings > Connections > Bluetooth**.
2. In **Bluetooth**, select **Visible**.
3. Enter a Bluetooth phone name for your phone. This will be the phone name that will be shown on another Bluetooth-enabled device when it searches and detects your phone.
4. Click **Done**.

Note Selecting the **Visible** option on the Bluetooth screen also turns on Bluetooth.

Bluetooth partnerships

A Bluetooth partnership is a relationship that you create between your phone and another Bluetooth-enabled device in order to exchange information in a secure manner.

Creating a partnership between two devices involves entering the same passcode on both devices, and this is a one-time process. Once a partnership is created, the devices can recognize the partnership and exchange information without entering a PIN again. Make sure the two devices are within a range, and Bluetooth is turned on and in visible mode.

To create a Bluetooth partnership

1. On the Home screen, click **Start > Settings > Connections > Bluetooth**.
2. Click **Menu > Devices**.
3. Click **Menu > New** to search for a new device.
Your phone searches for other Bluetooth-enabled devices and lists them.
4. Select the desired device name in the list.
5. Click **Next**.
6. Enter a passcode (1 up to 16 characters) to establish a secure connection, then click **Next**.

7. Wait for the paired device to accept the partnership:
 - If you are creating a Bluetooth partnership between your phone and another Bluetooth-enabled Pocket PC or phone, the receiving party needs to enter the same passcode that you specified.
 - If you are creating a Bluetooth partnership between your phone and computer, a balloon message will appear at the bottom-right of the computer screen, prompting your computer to accept the partnership. Click the message then enter the passcode.
8. On your phone, a message will appear, indicating that your phone has connected with the paired device. Click **OK**.
9. The name of the paired device is then displayed. You may edit and enter a new name for that device, then click **Next**.
10. Select the check boxes of services that you want to use from the paired device. Click **Done**.

To accept a Bluetooth partnership

1. Ensure that Bluetooth is turned on and in visible mode.
2. Click **Yes** when prompted to establish a partnership with the other device.
3. Enter a passcode (the same passcode that is entered on the device requesting the partnership) to establish a secure connection.
The passcode must be between 1 and 16 characters.
4. Click **Next**.
5. A message will appear, indicating that your phone has connected with the paired device. Click **OK**.
6. The name of the paired device is then displayed. You may edit and enter a new name for that device, then click **Next**.
7. Select the check boxes of services that you want to use from the paired device.
8. Click **Done**.

You can now exchange information with the other device.

To change the display name of a Bluetooth device

1. On the Home screen, click **Start > Settings > Connections > Bluetooth**.
2. Click **Menu > Devices**.
3. Select a detected Bluetooth device.
4. Click **Menu > Edit**.
5. Enter a new display name for the Bluetooth device, then click **Next**.
6. Click **Done**.

To delete a Bluetooth partnership

1. On the Home screen, click **Start > Settings > Connections > Bluetooth**.
2. Click **Menu > Devices**.
3. Select a Bluetooth device.
4. Click **Menu > Delete**.
5. Click **Done**.

Connect a Bluetooth hands-free or stereo headset

For hands-free phone conversations, you can use a Bluetooth hands-free headset such as a car kit with your phone. Your phone also supports A2DP (Advanced Audio Distribution Profile) which is for stereo audio over Bluetooth. This means that you can use a Bluetooth stereo headset with your phone for hands-free phone conversations as well as for listening to stereo music. Make sure that your stereo headset also supports A2DP.

Just like when connecting to any Bluetooth device, you also need to enter a passcode when connecting to a Bluetooth hands-free or stereo headset. The passcode is fixed and cannot be changed on a Bluetooth headset. Before you connect it with your phone, check for the proper passcode in the manufacturer's documentation.

To connect a Bluetooth hands-free or stereo headset

1. Make sure that both your phone and the Bluetooth headset are turned on and within close range, and that the headset is visible. Refer to the manufacturer's documentation to find out how to set the headset in visible mode.
2. On the Home screen, click **Start > Settings > Connections**.
3. Click **Bluetooth > Menu > Devices**.
4. Click **Menu > New**. Your device searches for other Bluetooth-enabled devices and displays them in the list.
5. Select the name of the headset, and click **Next**.
6. In **Passcode**, enter the alphanumeric passcode for the Bluetooth headset, then click **Next**.
7. Select the check box for the **Hands Free** service, and click **Done**.

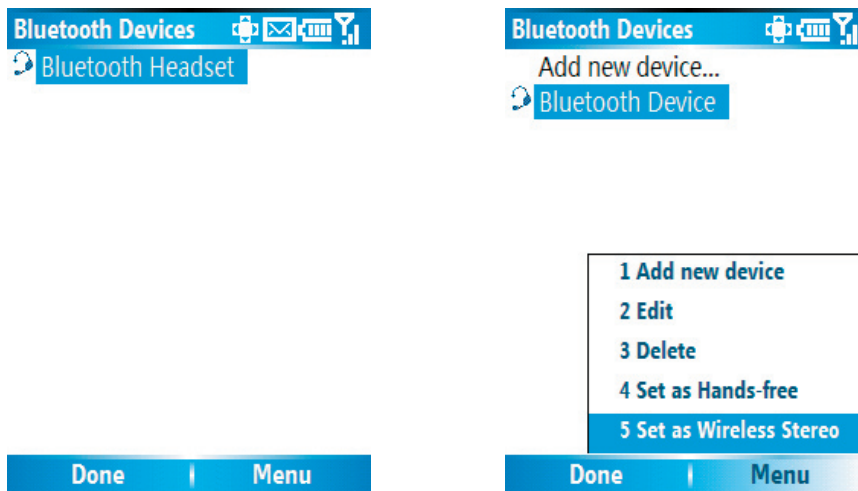

Note If the Bluetooth stereo headset becomes disconnected, turn the headset on and repeat steps 1 to 3 above. Select the stereo headset and click **Menu > Set as Wireless Stereo**.

Beam information using Bluetooth

You can beam information, such as contacts, calendar items, and tasks, as well as files from your phone to your computer or to another Bluetooth-enabled device.

Note If your computer does not have built-in Bluetooth capabilities, you need to connect and use a Bluetooth adapter or dongle on your computer.

To beam information from your phone to a computer

1. Set Bluetooth on your phone to visible mode. For information about this, see "To make your phone visible".
2. Next, set Bluetooth on your computer to visible mode, create a Bluetooth partnership, then enable your computer to receive Bluetooth beams.

If your computer has Windows XP SP2 and your computer's built-in or external Bluetooth adapter is supported by Windows XP SP2, do the following steps:

- a. On your computer, open **Bluetooth Devices** from the Control Panel then click the **Options** tab.
- b. Select the **Turn discovery on** and the **Allow Bluetooth devices to connect to this computer** options.
- c. Create a Bluetooth partnership between your phone and computer. For information about creating a partnership, see "Bluetooth partnerships".
- d. In the **Options** tab of **Bluetooth Devices**, select **Show the Bluetooth icon in the notification area**.
- e. To enable your computer to receive Bluetooth beams, right-click the Bluetooth icon at the bottom-right of your computer screen. A menu then opens. Click **Receive a File**.

Whereas if the Bluetooth adapter on your computer was installed using a third-party provided driver, do the following steps:

- a. Open the Bluetooth software that came with the Bluetooth adapter. This software varies by manufacturer, but in most cases, you will find a **Bluetooth Configuration** utility which you can open from the Control Panel.
 - b. Click the **Accessibility** tab in the Bluetooth Configuration dialog box, then select **Let other Bluetooth devices to discover this computer**.
 - c. Create a Bluetooth partnership between your phone and computer. For information about creating a partnership, see "Bluetooth partnerships".
 - d. Refer to the Bluetooth adapter's documentation for instructions on how to enable your computer to receive Bluetooth beams.
3. Now you are ready to beam. On your phone, select an item to beam. The item can be an appointment in your calendar, a task, a contact card, or a file.
 4. Click **Menu > Beam [type of item]**.
 5. Select the device name to which you want to beam to.
 6. Click **Beam**.
 7. If you beamed a calendar, task, or contact item to your computer and it is not automatically added to Outlook, click **File > Import and Export** to import it to Microsoft Outlook on your computer.

To beam information to a Bluetooth-enabled device such as another phone, create a Bluetooth partnership and then perform the steps 3 to 6 in the above procedure.

Notes

- If the computer or device you want to beam to cannot be detected by your phone, make sure that it is turned on, visible, and within close range of your phone.
- The default folder on your computer where beamed items are stored may be C:\Documents and Settings\your_username\My Documents.
- If your computer's Bluetooth adapter was installed using a third-party provided driver, the folder location where it stores beamed items will be indicated in the **Information Exchange** tab of the **Bluetooth Configuration** utility.

Use the phone as a Bluetooth modem

You can connect your phone to a notebook or desktop computer through Bluetooth and use the phone as a modem for the computer.

For the computer to use the Internet connection of your phone, activate Internet Sharing on your phone, then set up a Bluetooth Personal Area Network (PAN) between the computer and your phone.

1. On your phone, turn on Bluetooth and set it to **Visible** mode.
2. Initiate a Bluetooth partnership from your phone by following the steps in "To create a Bluetooth partnership."

Alternatively, you can initiate a Bluetooth partnership from the computer by following these steps (based on Windows XP SP2):

- a. In the Control Panel or System Tray, double-click the **Bluetooth Devices** icon.
 - b. In the Bluetooth Devices window, click **Add**.
 - c. The Add Bluetooth Device Wizard opens. Select the **My device is set up and ready to be found** check box, then click **Next**.
 - d. The wizard then detects your phone and displays its name in the dialog box. Select the phone name, then click **Next**.
 - e. Select **Let me choose my own passkey**, then enter a passkey (1 up to 16 digits) that will serve as an identification number for establishing a secure connection between your phone and the computer. Click **Next**.
 - f. A confirmation message then appears on your phone. Click **Yes** to accept the connection, enter the same passcode, then click **Next**.
 - g. On the computer, click **Finish** to exit the wizard.
 - h. On your phone's Partnership Settings screen, you can change the display name for the computer, then click **Finish**.
- 3.** Now, open the Internet Sharing program on your phone. Click **Start > Internet Sharing**.
 - 4.** Select **Bluetooth PAN** as the **PC Connection**.
 - 5.** From the **Network Connection** list, select the name of the connection that your phone uses to connect to the Internet.
 - 6.** Click **Connect**.
 - 7.** On your computer, set up a Bluetooth Personal Area Network (PAN) with your phone:
 - a. Click **Start > Control Panel > Network Connections**.
 - b. Under **Personal Area Network**, click the **Bluetooth Network Connection** icon.
 - c. Under **Network Tasks**, click **View Bluetooth network devices**.
 - d. In the Bluetooth Personal Area Network Devices dialog box, select your phone, then click **Connect**.
 - 8.** On the Internet Sharing screen on your phone, check if a connected status is displayed, which indicates that your computer has been successfully connected to the Internet using your phone as a Bluetooth modem.

Chapter 6

Exchanging Messages and Using Outlook

6.1 Using E-mail and Text Messages

6.2 Using MMS Messages

6.3 Using Pocket MSN Messenger

6.4 Using Calendar

6.5 Using Contacts

6.6 Using Tasks

6.7 Using Voice Notes

6.1 Using E-mail and Text Messages

Messaging is where all of your e-mail accounts and your text message account are located. You can send and receive Outlook e-mail, Internet e-mail through an Internet service provider (ISP), and text messages. You can also access e-mail from work using a virtual private network (VPN) connection.

Set up Outlook E-mail

When starting ActiveSync on your computer for the first time, the Synchronization Setup Wizard prompts you to set up a synchronization relationship. This allows you to synchronize Outlook e-mail and other information between your phone and your computer or the Exchange Server. If you have already set up synchronization through the wizard, then your phone is ready to send and receive Outlook e-mail. For information about the Synchronization Setup Wizard, see “To install and set up ActiveSync on the computer” in Chapter 3.

If you have not set up a synchronization relationship yet, do the following to set up your phone to synchronize Outlook e-mail:

1. To set up and connect to an over-the-air connection (1xRTT, 1xEVDO, or ISP dial-up) to synchronize remotely, follow the procedures in “Connecting to the Internet” in Chapter 5.
2. Disconnect your phone from your computer or LAN. (If you have an over-the-air connection, there is no need to disconnect.)
3. Click **Start > ActiveSync**.
4. If you want to synchronize e-mails directly with the Exchange Server on a private network such as your corporate network, follow the steps in “Synchronize Outlook information with Exchange Server” in Chapter 3.
5. Choose which information types to synchronize. Make sure **E-mail** is selected. For details, follow the steps in “To change which information is synchronized” in Chapter 3.

Every time you want to manually send or receive Outlook e-mail on your phone, just connect your phone to your computer, LAN, or over-the-air connection, then click **Sync** on the ActiveSync screen or click **Menu > Send/Receive** in Outlook on your phone.

For details about scheduling automatic synchronization or setting a synchronization time with the Exchange Server, see “Schedule synchronization with Exchange Server” in Chapter 3.

Set up a POP3/IMAP4 e-mail account

You need to set up an e-mail account that you have with an Internet service provider (ISP) or an account that you access using a VPN server connection (typically a work account) before you can send and receive e-mail.

1. On the Home screen, click **Start > Messaging > New Account**.

Note You can also open **Messaging** by pressing  and then  from the QWERTY keyboard.

2. In **Your e-mail provider**, select **Other (POP3/IMAP)** then click **Next**.
3. In **Your name**, enter your display name for e-mail messages.
4. In **E-mail address**, enter the e-mail address for this account.
5. Select **Attempt to obtain e-mail settings from the Internet** and click **Next**.

Auto configuration attempts to download necessary e-mail server settings so that you do not need to enter them manually. If the account is set up successfully, you will be prompted to send and receive e-mail.

If **Auto configuration** is unsuccessful or you have an account you access using a VPN server connection, contact your ISP or network administrator for the following information and enter it manually:

Setting	Description
User name	Enter the user name assigned to you by your ISP or network administrator. This is often the first part of your e-mail address, which appears before the at sign (@).
Password	Choose a strong password. You have the option to save your password so you do not need to enter it each time you connect to your e-mail server.
Domain	Not required for an account with an ISP. May be required for a work account.
Server type	Select POP3 or IMAP4.
Account name	Enter a unique name for the account, such as "Work" or "Home." This name cannot be changed later.
Network	Enter the type of network your e-mail server connects to.
Incoming server	Enter the name of your e-mail server (POP3 or IMAP4).
Require SSL connection	Select this to ensure you always receive e-mail for this account using an SSL connection. This enables you to receive personal information more securely. Please note that if you select this and your ISP does not support an SSL connection, you will not be able to connect to receive e-mail.
Outgoing server	Enter the name of your outgoing e-mail server (SMTP).
Outgoing server requires authentication	Select this if your outgoing e-mail server (SMTP) requires authentication. Your user name and password from above will be used.
Outgoing server settings	Your outgoing e-mail server may require different authentication settings than your incoming e-mail server.
Use different user name for outgoing server	Select this if your outgoing e-mail server requires a different user name and password than the ones you entered before.
User name	Enter your user name for the outgoing e-mail server.
Password	Enter your password for the outgoing e-mail server.
Domain	Enter the domain of the outgoing e-mail server.
Require SSL connection (Outgoing mail server only)	Select this to ensure you always send e-mail from this account using an SSL connection. This enables you to send personal information more securely. Please note that if you select this and your ISP does not support an SSL connection, you will not be able to send e-mail.

Send and receive messages

To compose and send an e-mail or text message

1. On the Home screen, click **Start > Messaging**.
2. Select an e-mail account, or select **Text Messages**. Then, click **Select**.
3. Click **New**.
4. Enter the e-mail address or phone number of one or more recipients, separating them with a semicolon (;). To access addresses and phone numbers from Contacts, in **To**, press ENTER and select a recipient from the list.
5. Enter a message.
6. Click **Send**.

Note If you are working offline, e-mail messages are moved to the Outbox folder and will be sent the next time you connect. Text messages are sent immediately.

Tips

- To set the priority of an e-mail message, click **Menu > Message Options**.
- To cancel any message, click **Menu > Cancel Message**.
- If you are sending a text message and want to know if it was received, before sending the message, click **Menu > Message Options**. Select **Request message delivery notification**.
- If you want the recipient to call you back after receiving your message, before sending the message, click **Menu > Message Options**, select **Send a callback number**, enter a number, and click **Done**.

To reply to or forward a message

1. From an open message, click **Reply**, or click **Menu > Reply All** or **Forward**.
2. Enter a message in the message area.
3. Click **Send**.

Notes If you are replying to or forwarding e-mail from Outlook E-mail, you will send less data if you do not edit the original message. This may reduce data transfer costs based on your rate plan.

To exclude your e-mail address when replying to all

When you reply to all the recipients of an e-mail, your own e-mail address will also be added to the recipient list. You can customize ActiveSync so that your e-mail address will be excluded from the recipient list.

1. On the Home screen, click **Start > ActiveSync**.
2. Click **Menu > Options**.
3. Select **E-mail**, and click **Settings**.
4. Click **Menu > Advanced**.
5. In the **Primary e-mail address** text box, enter your e-mail address.

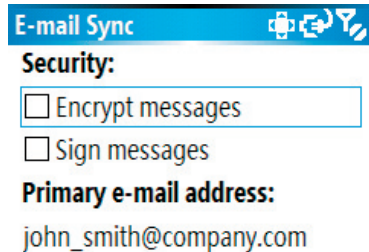

6. Click **Done**.

To add an attachment to an e-mail message

1. In a new message, click **Menu > Insert** and then click **Picture** or **Voice Note**.
2. Select the picture you want to attach, or record a voice note.

To download attachments

- In an open message with an attachment, select the attachment. The attachment is downloaded the next time you synchronize or connect to your e-mail server and send and receive e-mail.

Download messages

The manner in which you download messages depends on the type of account you have:

- To send and receive e-mail for an Outlook E-mail account, begin synchronization using ActiveSync. For more information, see “Set up Outlook e-mail” in this chapter.
- To send and receive e-mail messages for an e-mail account that you have with an Internet Service Provider (ISP) or that you access using a VPN server connection (typically a work account), download

messages through a remote e-mail server. For more information, see "To download messages from the server" in this chapter.

- Text messages are automatically received when your phone is turned on. When your phone is turned off, messages are held by your service provider until you turn on your phone again.

To download messages from the server

To send and receive e-mail messages for an e-mail account that you have with an Internet Service Provider (ISP) or that you access using a VPN server connection (typically a work account), you first need to connect to the Internet or your corporate network, depending on the account.

1. On the Home screen, click **Start > Messaging**.
2. Select the e-mail account.
3. Click **Menu > Send/Receive**. The messages on your phone and e-mail server are synchronized as follows: new messages are downloaded to the phone Inbox folder, messages in the phone Outbox folder are sent, and messages that have been deleted from the server are removed from the phone Inbox folder.

Tip If you want to download the entire message, select the message and click **Menu > Download Message**. The remainder of the message will be downloaded the next time you send and receive e-mail.



Individually sign and encrypt a message

Encrypting an Outlook e-mail message protects the privacy of the message by converting it from plain, readable text into cipher (scrambled) text. Only the recipient who has the authorization key can decipher the message.

Digitally signing a message applies your certificate with the authorization key to the message. This proves to the recipient that the message is from you and not from an imposter or a hacker, and that the message has not been altered.

To digitally sign and encrypt a new message

1. In the message list, select **Outlook E-mail**.
2. Click **New**.
3. Click **Menu > Message Options**.
4. In the **Security** field, select the **Encrypt message** and **Sign message** check boxes then click **Done**.

Message Options   

Priority:
Normal ◀ ▶

Security:
 Encrypt message
 Sign message

Language:
Western European ◀ ▶

Done | Cancel

Verify the digital signature on a signed message you receive

To verify a digital signature in the message that you receive, do the following:

1. Open the Outlook e-mail message that has been digitally signed.
2. At the top of the message, click **View Signature Status**.
3. Click **Menu > Check Certificate**.

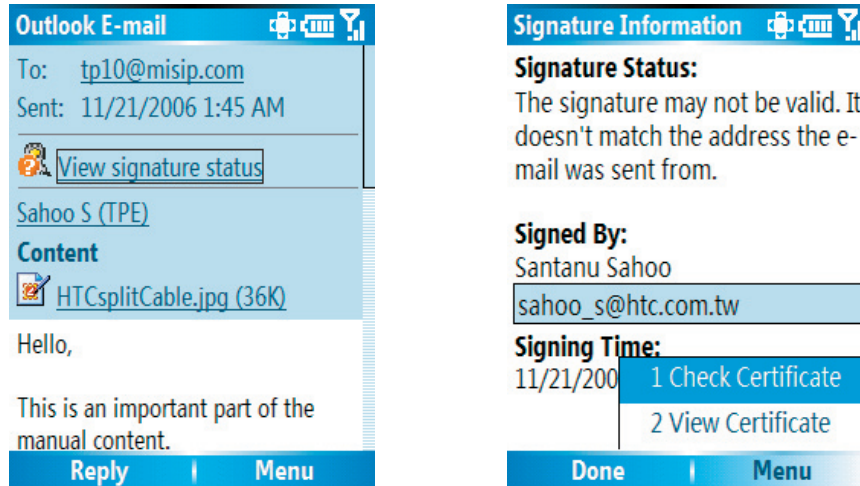

4. To view the details of the certificate in the message, click **Menu > View Certificate**.

Note There can be several reasons why a digital signature is not valid. For example, the sender's certificate may have expired, it may have been revoked by the certificate authority, or the server that verifies the certificate is unavailable. Contact the sender to report the problem.

Manage folders

Each Messaging account has its own folder hierarchy with five default Messaging folders: Inbox, Outbox, Deleted Items, Drafts, and Sent Items. The messages you receive and send through the account are stored in these folders. You can also create additional folders within each hierarchy. Folders for e-mail accounts behave differently depending on the type of e-mail account you have.

If you set up an Outlook E-mail account to sync with Exchange Server or a desktop PC, e-mail messages in the Inbox folder in Outlook will be synchronized automatically with your phone. You can select to synchronize additional folders by designating them for synchronization. The folders you create and the messages you move will then be mirrored on the e-mail server. For example, if you move two messages from the Inbox folder to a folder named Family, and you have designated Family for synchronization, the server creates a copy of the Family folder and copies the messages to that folder. You can then read the messages while you are away from your PC. You can only create and delete folders on devices when you are connected to an Exchange e-mail server.

Similar to the Outlook account, if you set up an account to send and receive mail using an IMAP4 e-mail server, all messages on the phone are copies of the messages on the server. The folders you create locally on the phone and the e-mail messages you move to these folders are mirrored on the e-mail server. Moving a message on the phone moves the copy on the server the next time you send and receive e-mail for that account. Therefore, messages are available to you anytime you connect to your e-mail server, whether it is from your phone or PC. This synchronization of folders occurs whenever you connect to your e-mail server, create new folders, or rename/delete folders when connected. You can also set different download options for each folder.

If you set up an account to send/receive mail using a POP3 e-mail server, e-mail messages you move to the Deleted Items folder on the phone will break the link between the messages on the phone and their copies on the e-mail server. The next time you connect to send and receive mail, the e-mail server will detect the messages that are in the Deleted Items folder on the phone and will delete those messages from the e-mail server. All other messages in other folders remain on both the phone and the e-mail server.

6.2 Using MMS Messages

Creating and sending Multimedia Message Service (**MMS**) messages to your friends and family is fun and easy. You can include or capture photos or video clips, include or record audio, add text, then send them along with your MMS message.

To access MMS

Do any of the following:

- On the Home screen, click **Start > Messaging > MMS**.
- From the Pictures & Videos program, select a picture in My Pictures, and click **Menu > Send**. Select **MMS** as the messaging account to send the picture along with the message.
- From the Camera program, capture a photo or an MMS video clip then click (📧). In the menu, select **Send via MMS** and click **Send**.

To access MMS message folders

- Click **Start > Messaging > MMS**, then click **Menu > Folders**.

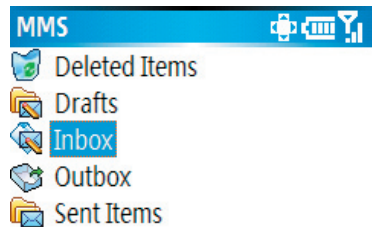

MMS Message Folders

Edit MMS settings

When you send an MMS message, an SMS notification message will first be sent to the recipient, while your MMS message will be temporarily stored on an MMS server of your wireless service provider. When others send you an MMS message, similarly, the MMS message will be stored on the MMS server, waiting for you to retrieve it. Hence, your phone must be configured with the location of the MMS server for you to be able to send and receive MMS messages on your phone.

When you purchase your phone, it is already preset with your wireless service provider's MMS server settings. If you accidentally lost the preset settings or you changed to another wireless service provider, follow the steps below to configure MMS settings.

To configure MMS settings

1. On the MMS main screen, click **Menu > Options > Account Settings** to open the Preferences screen.
2. Select or clear the provided check boxes according to your needs. You can choose to keep track of your MMS messages, retrieve messages immediately, accept or reject messages, request a delivery or read receipt. You can also specify a resolution for images you send and message delivery attempts.
3. On the Preferences screen, click **Menu > MMSC Settings > Edit** to access Multimedia Messaging Service Center (MMSC) settings.

4. Check if your phone is preset with MMS server settings.

If there are no preset settings, click **Menu > New** on the MMSC Settings screen and enter the following information, which you can get from your wireless service provider:

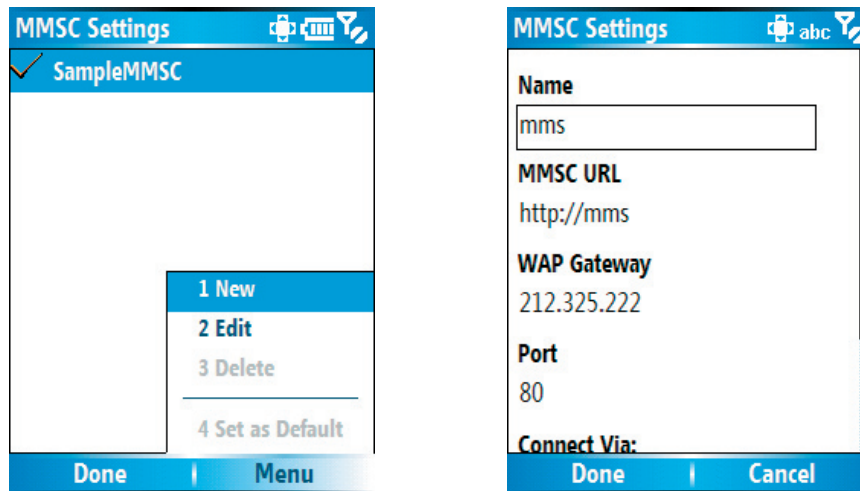

- **Name.** A descriptive name, such as your wireless service provider name.
- **MMSC URL.** URL address of the MMS server.
- **WAP Gateway.** Location of the MMS server, which is usually in the form of an IP address.
- **Port.** HTTP port number used for connecting to the MMS server and for file transfer.
- **Connect Via.** Select the connection your phone uses for MMS.
- **Max. Sending Size.** Select the maximum MMS message size allowed by your wireless service provider.
- **WAP Version.** Select either **WAP 1.2** or **WAP 2.0**, depending on which one is being used by your wireless service provider.

5. Click **Done**.

The MMS server settings will then be added as an entry on the MMS Configuration screen.

Note If you add several MMS service providers to the MMSC Settings screen, you can choose one as your default MMS provider. Select the MMS provider's name in the list, then click **Menu > Set as Default**.

Create and send MMS messages

You can compose MMS messages in a combination of various slides, where each slide can consist of a photo, audio or video clip, and/or text.

Notes

- Please note that MMS is a charged service. In order to use MMS successfully, this has to be provisioned on your mobile account. Please contact the wireless service provider to have this provisioned as part of your calling plan.
- Please ensure the size of the MMS is within the limits of the wireless service provider if sending to another mobile phone user or sending to an e-mail address.

To start composing an MMS message

1. On the Home screen, click **Start > Messaging > MMS > New**.
2. On the Compose New screen, select either **New Flix Message** or **New Pix Message** based on whether you want to send video clip(s) or picture(s) with the message.
3. In **To**, enter the recipient's phone number or e-mail address directly, or press ENTER to choose a phone number or an e-mail address from Contacts. You can also click **Menu > Recipients > Add** to add a new contact entry.

4. In **Subject**, enter a subject for your message.
5. Click either **Insert Picture** or **Insert Video** to select a photo or video clip from the Select Media screen and insert it.
6. Enter text and insert audio clips (only available if you have selected **New Pix Message**) by clicking the respective fields.
7. Click **Send** to send the message.

Note To send a copy of this message to others, access **Cc** and **Bcc** by clicking **Menu > Send Options**. In these fields, enter the recipient's phone number or e-mail address or click **Menu > Recipients > Add** to add from Contacts.

The following symbols act as shortcuts to some of the options on the MMS Message screen.

- Click ◀ to go to the previous slide.
- Click ▶ to go to the next slide.

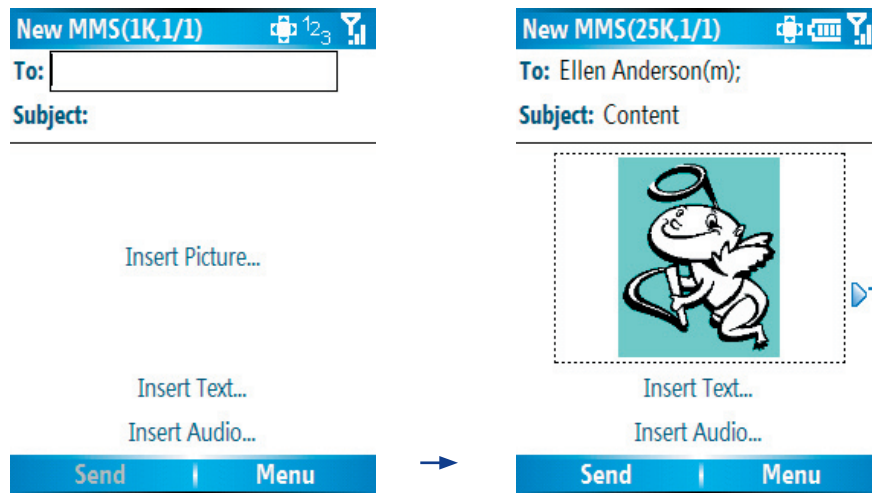

Composing an MMS (New Pix Message)

To create an MMS message from a template

- On the blank MMS message screen, click **Menu > Template > New from Template** to compose a message using a predefined template.

Note To save a message as a template, create a message or open an existing message, and click **Menu > Template > Save as Template**.

To insert a photo or video clip into an MMS message

You can add either a still image or a video clip to each individual slide on the MMS message screen depending on which MMS message you have chosen. It can be either a new video message (**New Flix Message**) or a new picture message (**New Pix Message**).

1. Click **Insert Picture** or **Insert Video** to insert a photo or video clip.
2. Select a picture or video clip on the Select Media screen. This is the My Pictures folder where images and video clips are displayed in thumbnail view. To navigate to any other folder containing pictures or videos, click **Menu > Change Folder**.
3. Select a photo or video clip using NAVIGATION, and click **Select** or **Menu > Select** to insert it.

On the Select Media screen, you can view the thumbnails in list view, open an item to view it, or delete an item by clicking **Menu** and choosing the appropriate option. You can even discard this photo or video clip by pressing BACK. To capture a new photo or video clip and send it immediately with the message, click **Menu > Capture > Picture** or **Menu > Capture > Video**. The newly captured photo or video clip is automatically inserted into your message.

To add predefined text to an MMS message

You can instantly add text to any slide from a list of predefined words or phrases, called My Text.

- On the MMS message screen, click **Insert Text > Menu > My Text** and then click **Select** to add a text string from the My Text list.

Note To edit or delete a phrase on the My Text list, select a text string and click **Menu > Delete**. To create and add a new phrase to the list, click **Menu > New**.

To add emoticons or Favorites URLs to an MMS message

Add emoticons or Favorites URLs to your messages.

- On the MMS message screen, click **Insert Text > Menu > Insert Emoticon** or **Add Favorite**. In the screen that opens, select the emoticon or URL you want to add then click **Select**.

Note The MMS Favorites list is based on the Internet Explorer Mobile Favorites list.

To add an audio clip to an MMS message

You can add audio clips to your MMS messages while sending pictures (when you select **New Pix Message**). However, you can add only one audio clip per slide.

1. Click **Insert Audio** to insert an audio clip.
Select an audio clip on the Select Audio screen.

Note By default, the audio clips listed on the Select Audio screen are from the My Sounds folder. To navigate to any other folder containing audio clips, click **Menu > Change Folder**.

2. Select an audio clip using NAVIGATION, and click **Select** or **Menu > Select** to insert it.

Note You can play and listen to the audio clip by clicking **Menu > Play** before you insert it.

Otherwise, to record a new audio clip, click **Menu > Capture Audio**. Then click **Record** to start recording and **Stop** to stop recording. Click **Play** to listen to the new audio clip you captured, then click **Done**.

Click **Select** to add the audio file to the MMS message.

Note The **Insert Audio** option is not available while composing a New Flix Message as it is assumed that the video clip to be sent with the message is accompanied with audio, by default.

To set options for an MMS message

While composing an MMS message, you can set the following options for the message by clicking **Menu**.

Option	Allows you to
Recipients	Specify the phone number or e-mail address of the recipient(s).
Insert Media	Choose the type of media you want to insert to your MMS message.
Remove Media	Choose the type of media you want to delete from the MMS message.
Slides	Add and remove slides, view the next or previous slides, and specify the duration of slides.
Template	Compose a message using a predefined template, and save a composed or existing message as a template.
Capture	Capture a photo, audio or video clip to be inserted into the message.
Cancel Message	Cancel the message and go back to the MMS Messaging folders screen.
Attachments	Choose to attach a vCard, vCalendar, or other file.
Send via SMS	Only the text portion of your message will be sent. All other media will be discarded.
Preview Message	Play back the contents of the MMS message before sending it.
Options	
Background	Choose a background color from the list.
Text Layout	Change the position of the text. Click Menu to select a text layout.
Send Options	Specify the message delivery time, validity, priority, class, and other settings for a message.

View, reply, and block MMS messages

To receive MMS messages

- On any MMS message folder screen, click **Menu > Send/Receive**.
By default, messages are automatically downloaded to your phone.

To view an MMS message

You can view MMS messages in several ways.

- Press ENTER to view and play the message on your phone. Click **Pause** or **Menu > Stop** to pause or stop the playback of the message.
- Click **Menu > Object View** to see a list of files included in the message. To open a file, select it and click **Open**. To save a file, select it, and click **Save**, **Menu > Save Audio**, or **Menu > Save Photo**.
- View each slide included in the message by clicking **Menu > Next**.

To reply to an MMS message

- Click **Menu > Reply > Reply** to reply to the sender of the message, or click **Menu > Reply > Reply All** to reply to all persons listed in the To and CC boxes of the message. Click **Menu > Reply > Forward** to forward the message to someone else.

To block a phone number from sending you MMS messages

You can choose to block a phone number from sending you MMS messages if you do not want to receive future MMS messages from that number.

1. View the MMS message then click **Menu > Show Message Details**.
2. In the MMS Details screen, select the contact in the **From** field then click **Menu > Open**.
3. Select the number on the screen then press ENTER. On the menu that opens, click **Save to Blacklist**.

Note By adding the number to the Blacklist, you will not be able to receive future MMS messages from that number. To edit the MMS Blacklist, on the MMS message screen, click **Menu > Options > Account Settings > Menu > Edit Blacklist**. Here you can remove a number from the Blacklist.

6.3 Using Pocket MSN Messenger

Pocket MSN Messenger delivers the features of MSN Messenger to your phone. With Pocket MSN Messenger, you can do the following:

- Send and receive instant messages.
- See which contacts are online or offline.
- Subscribe to status updates for selected contacts so you know when they come online.
- Block contacts from seeing your status or sending you messages.

Before you can use MSN Messenger, your phone must be connected to the Internet. For information about setting up an Internet connection, see “Connecting to the Internet” in Chapter 5.

Important Note You must have either a Microsoft .NET Passport or a Hotmail account to use MSN Messenger. If you have a Hotmail.com or MSN.com e-mail address, you already have a Passport. To get a Passport account, go to <http://www.passport.com>. To get a Hotmail account, go to <http://www.hotmail.com>.

To start MSN Messenger

On the Home screen, click **Start > Pocket MSN > MSN Messenger**.

To sign in or out

- On the main MSN Messenger screen, click **Sign In**. Enter the e-mail address and password for your Passport or Hotmail account, and click **Sign In**.
Signing in may take several minutes, depending on the connection speed.
- To sign out, click **Menu > Sign Out**.

To add or delete contacts

- To add a contact, click **Menu > Add Contact**, and follow the instructions on the screen.
- To delete a contact, select the contact and click **Menu > Delete Contact**.

To send an instant message

1. Click the contact to whom you will send a message.
2. Enter your message in the text entry area at the bottom of the screen, and click **Send**.

Note To quickly add common phrases, click **Menu > My Text** and select a phrase in the list.

To block or unblock contacts

- To block a contact from seeing your status and sending you messages, select the contact and click **Menu > Block**.
- To unblock a contact, select the contact, and click **Menu > Unblock**.

To change your own Messenger status

1. Click your own name at the top of the screen.
Your current status is indicated by a bullet point in the displayed list.
2. Select a status (such as Out To Lunch) from the list.

To change your display name

1. Click **Menu > Options**.
2. In **My display name**, enter the name you want to display to others in MSN Messenger then click **Done**.

6.4 Using Calendar

Use Calendar to schedule appointments, including meetings and other events. Your appointments for the day can be displayed on the Home screen. If you use Outlook on your PC, you can synchronize appointments between your phone and PC. You can also set Calendar to remind you of appointments with a sound or flashing light, for example.

To schedule an appointment

1. On the Home screen, click **Start > Calendar**.
2. Click **Menu > New Appointment**.
3. Enter information about the appointment.
4. To schedule an all-day event, in **End time**, select **All day event**.
5. Click **Done**.

Note All-day events do not occupy blocks of time in Calendar; instead, they appear in banners at the top of the calendar.

To make an appointment recurring

1. On the Home screen, click **Start > Calendar**.
2. Click the appointment and click **Edit**.
3. Scroll to **Occurs** and click one of the recurrence options.
4. Click **Done**.

To view your schedule

You can view your schedule in three different views: Month, Week, and Agenda.

1. On the Home screen, click **Start > Calendar**.
2. Do one of the following:
 - Click **Menu > Month View**.
 - Click **Menu > Week View**.
 - Click **Menu > Go to Today**, or from **Week** or **Month** view, click **Menu > Agenda View**.

To send a calendar appointment

You can send a calendar appointment to another phone over MMS.

1. On the Home screen, click **Start > Calendar**.
2. Select an appointment, then click **Menu > Send as vCalendar**.
3. Enter the recipient in the **To** line of the MMS message, then click **Send**.

Tip You can also beam an appointment or a calendar item.

6.5 Using Contacts

Contacts is your address book and information storage for the people and businesses you communicate with. Store phone numbers, e-mail addresses, home addresses, and any other information that relates to a contact, such as a birthday or an anniversary date. You can also add a picture or assign a ring tone to a contact.

From the contact list, you can quickly communicate with people. Click a contact in the list for a summary of contact information. From there, you can call or send a message.

If you use Outlook on your PC, you can synchronize contacts between your phone and PC.

To create a new contact on your phone

1. On the Home screen, click **Start > Contacts > New**.
2. Enter information for the new contact.
3. Click **Done**.

Tips

- If someone who is not in your list of contacts calls you or sends you a message, you can quickly create a contact from Call History or from the message by clicking **Menu > Save to Contacts**.
- In the list of contact information, you will see where you can add a picture or assign a ring tone to a contact.

To view and edit a contact information

1. On the Home screen, click **Start > Contacts**.
2. Click the contact whose information you want to view.

3. To edit the information, click **Menu > Edit**.
4. When finished making changes, click **Done**.

To call a contact from the contact list

1. On the Home screen, click **Start > Contacts**.
2. Click the contact to call.
3. Press TALK (📞). The contact's default phone number is dialed.

Tip To call a phone number other than the default, click the contact, scroll to the number you want to dial, and press TALK (📞).

To send an e-mail to a contact

1. On the Home screen, click **Start > Contacts**.
2. Click the contact.
3. Click the e-mail address.
4. Select the e-mail account to use.
5. Enter a subject, compose your message, and click **Send**.

To send a text message to a contact

1. On the Home screen, click **Start > Contacts**.
2. Click the contact, and click **Menu > Send Text Message**.
3. Compose your message, and click **Send**.

To find a contact

1. On the Home screen, click **Start > Contacts**.
2. If you are not in Name view, click **Menu > View By > Name**.
3. Do one of the following:
 - Begin entering a name or phone number of the contact until the contact is displayed. Pressing more than one key continues to narrow down the search.
 - Filter the list by categories. In the contact list, click **Menu > Filter**. Then click a category you have assigned to a contact. To show all contacts again, select **All Contacts**.
 - Locate the contact by company. In the contact list, click **Menu > View By**, and click **Company**. Click the company to see the contacts who work there.

To send contact information of someone to another person through text message

1. On the Home screen, click **Start > Contacts** then select the contact whose information you want to send.
2. Click **Menu > Send Contact > Text Message**. Select the contact information that you want to send and click **Done**.
3. In the new text message, enter the address of the person to whom you are sending the contact information and click **Send**.

To find a contact online

In addition to having contacts on your phone, you can also access contact information from your organization's Global Address List (GAL). GAL is the address book that contains all user, group, and distribution list e-mail addresses of your organization, and it is stored on the Exchange Server. By having direct online access to it from your phone, it is quick and easy for you to plan a meeting and e-mail a meeting request immediately to anyone in your organization.

Access to the GAL is available if your organization is running Microsoft Exchange Server 2003 SP2 and you have completed your first synchronization with the Exchange Server.

1. Synchronize with Exchange Server if you have never done so.
2. Click **Start > Contacts > Menu > View By > Name**.
3. Do either of the following:
 - In Contacts, click **Menu > Find Online**.
 - In a new message, in the **To** box, click **Menu > Add Recipient > Menu > Find Online**.

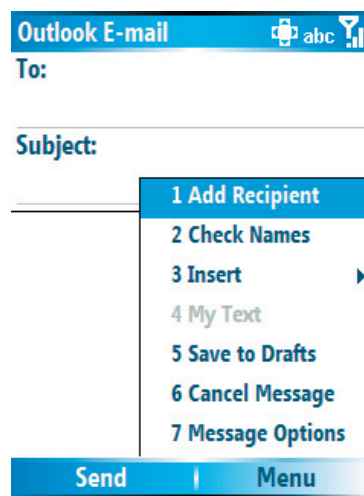
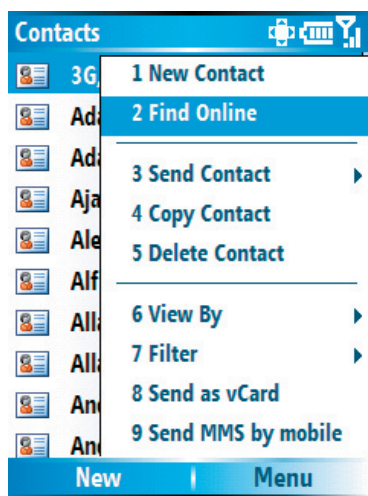

4. Enter the contact name and click **Find**. Select one contact in the result list and click **Select**.

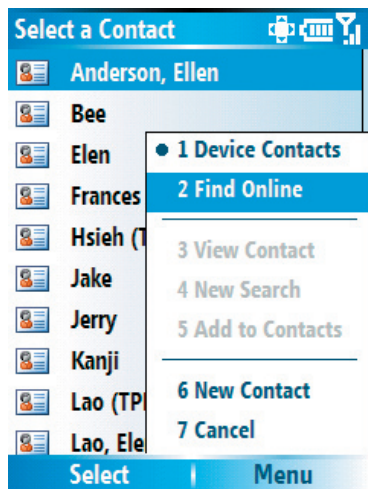

Notes

- Your phone must be set up with a data connection.
- You can search on the following information as long as that information is included in your organization's GAL: First name, Last name, E-mail name, Display name, E-mail address, or Office location.

To filter the contact list

Contacts that have categories assigned are displayed in the list when you filter by category.

1. On the Home screen, click **Start > Contacts**.
2. Click **Menu > Filter**.
3. Click a category to filter.

To assign a ring tone to a contact

To easily identify who is calling you, you can assign a custom ring tone to each contact.

1. On the Home screen, click **Start > Contacts**.
2. Click the contact you want to assign a ring tone to.
3. Click **Menu > Edit**.
4. Click **Custom ring tone** and select the ring tone you want.
5. Click **Done**.

To assign a picture to a contact

1. On the Home screen, click **Start > Contacts**.
2. Click the contact.
3. Click **Menu > Edit**.
4. Click **Picture**.
5. Click the picture you want to add.

To send a contact's details

You can send a contact card to another phone over MMS.

1. On the Home screen, click **Start > Contacts**.
2. Select a contact, then click **Menu > Send as vCard**.
3. Enter the recipient in **To** of the MMS message, then click **Send**.

6.6 Using Tasks

Use Tasks to keep track of things you need to do. A task can occur once or repeatedly (recurring). You can set reminders for your tasks and you can organize them using categories. Your tasks are displayed in a task list. Overdue tasks are displayed in red.

To create a task

1. On the Home screen, click **Start > Tasks**.
2. In the **Enter new task here** box, enter the task name and press ENTER.

Notes

- You can synchronize information on your phone with your PC to keep your task list up to date in both locations.
- If you create a new task with a reminder on your PC and then synchronize tasks with your phone, the reminder will play at the time that was set on your PC.

To delete a task

1. On the Home screen, click **Start > Tasks**.
2. Select the task, and click **Menu > Delete Task**.

To locate a task

1. On the Home screen, click **Start > Tasks**.
2. In the task list, do one of the following:
 - To sort the list, click **Menu > Sort by**, and click a sort option.
 - To filter the list by category, click **Menu > Filter**, and click the category you want displayed.

Note Categories appear only in tasks that are synchronized with your PC.

Tip To filter your tasks further, click **Active Tasks** or **Completed Tasks**.

To mark a task as completed

1. On the Home screen, click **Start > Tasks**.
2. Select the task, and click **Complete**.

6.7 Using Voice Notes

Use Voice Notes to create short voice recordings. Voice notes are included in the All Notes list and are named consecutively (Recording1, Recording2, and so on).

To create a voice note

1. On the Home screen, click **Start > Voice Notes**.
2. Hold the phone's microphone near your mouth.
3. Click **Record** and say your voice note.
4. Click **Stop** to stop recording a voice note.

To delete a voice note

1. On the Home screen, click **Start > Voice Notes**.
2. Select the voice note to delete.
3. Click **Menu > Delete**.
4. Click **Yes**.

Tip If you delete a voice note that has a default name, such as Recording1, this name becomes available for a new voice note.

To listen to a voice note

1. On the Home screen, click **Start > Voice Notes**.
2. Select the voice note to play, and press ENTER.

Tip To stop listening to the voice note, click **Stop** while the voice note is playing.

To use a voice note as a ring tone

1. On the Home screen, click **Start > Voice Notes**.
2. Select the voice note, and click **Menu > Set As Ringtone**.

Chapter 7

Experiencing Multimedia

7.1 Using Camera and Video Recorder

7.2 Using Pictures & Videos

7.3 Using Windows Media Player

7.4 Using Streaming Media

7.5 Using MIDlet Manager

7.1 Using Camera and Video Recorder

Taking photos and shooting video clips with audio are easy with your phone's built-in camera. The camera on your phone operates in landscape orientation with the fullscreen preview.

To open Camera or Video Recorder

Do any of the following:

- On the Home screen, click **Start > Camera**.
- On the Home screen, click **Start > Video Recorder**.
- Press the CAMERA button.

To exit Camera or Video Recorder

- Press END (📞).

To capture photos and video clips

You can do one of the following to capture photos and video clips from the Camera screen:

- Press the CAMERA button to take a photo. Also, press the CAMERA button to start recording video, then press it again to stop recording.
- Alternatively, you can press the ENTER button to take a photo. Also press this button to start recording video; then press it again to stop recording.

Capture modes

The Camera program lets you capture pictures and video clips using various built-in modes. By default, Camera opens in the capture mode you last accessed.

To change the capture mode

- On the Camera screen, press the right SOFT KEY (📷) then use the left SOFT KEY (⏪) to navigate to 📷 > **Mode**. Use NAVIGATION CONTROL to select a capture mode from the list.

The available capture modes are as follows:

Capture mode	Function
Photo (📷)	Captures standard still images.
Video (📹)	Captures video clips, with or without audio.
MMS Video (📹)	Captures video clips suitable for sending via MMS.
Contacts Picture (📷)	Captures a still image suitable for assigning as an identification photo to a contact.
Picture Theme (📷)	Captures still images and places them within frames.
Panorama (📷)	Captures a sequence of still images continuously in one direction, and allows stitching of all the images to create a panoramic view of a scenery.
Sports (📷)	Captures a sequence of still images (3 or 5 frames) automatically for a short duration at a defined frequency.