

ELECTROMAGNETIC EMISSIONS COMPLIANCE REPORT

INTENTIONAL RADIATOR CERTIFICATION TO FCC PART 22 SUBPART H and PART 24 SUBPART E

OF

Product Name: PDA Phone

Brand Name: hTC

Model Name: KAIS140

FCC ID: NM8KSJ

Report No.: ER/2008/20003

Issue Date: Feb. 26, 2008

FCC Rule Part: 2, 22H & 24E

Prepared for: High Tech Computer Corp.
23 Xinghua Rd., Taoyuan 330, Taiwan, R.O.C.

Prepared by: SGS Taiwan Ltd.
Electronics & Communication Laboratory
No. 134, Wu Kung Rd., Wuku Industrial
Zone, Taipei County, Taiwan.

Note: This report shall not be reproduced except in full, without the written approval of SGS Taiwan Ltd. This document may be altered or revised by SGS Taiwan Ltd. personnel only, and shall be noted in the revision section of the document.

VERIFICATION OF COMPLIANCE

Applicant: High Tech Computer Corp.
23 Xinghua Rd., Taoyuan 330, Taiwan, R.O.C.

Product Name: PDA Phone

FCC ID Number: NM8KSJ

Brand Name: hTC

Model No.: KAIS140

Model Difference: N/A

File Number: ER/2008/20003

Date of test: Feb. 01, 2008 ~ Feb. 20, 2008

Date of EUT Received: Feb. 01, 2008

We hereby certify that:

The above equipment was tested by SGS Taiwan Ltd. Electronics & Communication Laboratory. The test data, data evaluation, test procedures, and equipment configurations shown in this report were made in accordance with the procedures given in TIA/EIA-603-1-1998 and the energy emitted by the sample EUT tested as described in this report is in compliance with conducted and radiated emission limits of FCC Rule FCC PART 22 subpart H and FCC PART 24 subpart E.

The test results of this report relate only to the tested sample identified in this report.

Test By: Bondi Liu **Date** Feb. 26, 2008

Bondi Liu / Engineer

Prepared By: Alex Hsieh **Date** Feb. 26, 2008

Alex Hsieh / Sr. Engineer

Approved By Vincent Su **Date** Feb. 26, 2008

Vincent Su / Manager

Version

Version No.	Date
00	Feb. 26, 2008
01	Mar. 11, 2008
02	Mar. 13, 2008

This document is issued by the Company subject to its General Conditions of Service printed overleaf or available on request and accessible at www.sgs.com. Attention is drawn to the limitations of liability, indemnification, and Jurisdictional issued defined therein. Unless otherwise stated, the results shown in this test report refer only to the sample(s) tested. This document cannot be reproduced except in full, without prior approval of Company. Any unauthorized alteration, forgery or falsification of the content or appearance of this report is unlawful and offenders may be prosecuted to the fullest extent of the law. 此報告是遵循本公司訂定之通用服務條款所製作發放，請注意此條款列印於背面，亦可在www.sgs.com中查閱。將本公司之義務，免責，管轄權皆明確規範之。除非另有說明，此報告結果僅對檢驗之樣品負責。本報告未經本公司書面許可，不可部份複製。對本報告內容或外觀之任何未經授權之變更、偽造、竄改皆屬非法，違犯者將會被依法追訴。

Table of Contents

1. GENERAL INFORMATION	6
1.1 Related Submittal(s) / Grant (s)	8
1.2 Test Methodology	8
1.3 Test Facility	8
1.4 Special Accessories	8
1.5 Equipment Modifications	8
2. SYSTEM TEST CONFIGURATION	9
2.1 EUT Configuration	9
2.2 EUT Exercise	9
2.3 Test Procedure	9
2.4 Configuration of Tested System	10
3. SUMMARY OF TEST RESULTS	11
4. DESCRIPTION OF TEST MODES	11
5. RF POWER OUTPUT MEASUREMENT	12
5.1 Standard Applicable	12
5.2 Test Set-up:	12
5.3 Measurement Procedure	12
5.4 Measurement Equipment Used:	13
5.5 Measurement Result	14
6. ERP, EIRP MEASUREMENT	15
6.1 Standard Applicable	15
6.2 Test SET-UP (Block Diagram of Configuration)	15
6.3 Measurement Procedure	17
6.4 Measurement Equipment Used:	18
6.5 Measurement Result	19
6.6 Measurement Result	20
7. 99% OCCUPIED BANDWIDTH MEASUREMENT	21
7.1 Standard Applicable	21
7.2 Test Set-up:	21
7.3 Measurement Procedure	21
7.4 Measurement Equipment Used:	22
7.5 Measurement Result:	23

This document is issued by the Company subject to its General Conditions of Service printed overleaf or available on request and accessible at www.sgs.com. Attention is drawn to the limitations of liability, indemnification, and Jurisdictional issued defined therein. Unless otherwise stated, the results shown in this test report refer only to the sample(s) tested. This document cannot be reproduced except in full, without prior approval of Company. Any unauthorized alteration, forgery or falsification of the content or appearance of this report is unlawful and offenders may be prosecuted to the fullest extent of the law. 此報告是遵循本公司訂定之通用服務條款所製作發放，請注意此條款列印於背面，亦可在www.sgs.com中查閱。將本公司之義務，免責，管轄權皆明確規範之。除非另有說明，此報告結果僅對檢驗之樣品負責。本報告未經本公司書面許可，不可部份複製。對本報告內容或外觀之任何未經授權之變更、偽造、竄改皆屬非法，違犯者將會被依法追訴。

8. OUT OF BAND EMISSION AT ANTENNA TERMINALS	30
8.1 Standard Applicable	30
8.2 Test SET-UP	30
8.3 Measurement Procedure.....	30
8.4 Measurement Equipment Used:.....	31
8.5 Measurement Result.....	32
9. FIELD STRENGTH OF SPURIOUS RADIATION MEASUREMENT	40
9.1 Standard Applicable	40
9.2 EUT Setup (Block Diagram of Configuration)	40
9.3 Measurement Procedure.....	42
9.4 Measurement Equipment Used:.....	43
9.5 Measurement Result.....	43
10 FREQUENCY STABILITY V.S. TEMPERATURE MEASUREMENT	56
9.6 Standard Applicable	56
9.7 Test Set-up:	56
9.8 Measurement Procedure.....	56
9.9 Measurement Equipment Used:.....	57
9.10 Measurement Result.....	58
11. FREQUENCY STABILITY V.S. VOLTAGE MEASUREMENT	59
10.1 Standard Applicable	59
10.2 Test Set-up:	59
10.3 Measurement Procedure.....	59
10.4 Measurement Equipment Used:.....	60
10.5 Measurement Result.....	61
12. AC POWER LINE CONDUCTED EMISSION TEST	62
11.1 Standard Applicable	62
11.2 EUT Setup.....	62
11.3 Measurement Procedure.....	62
11.4 Measurement Equipment Used:.....	63
11.5 Measurement Result.....	63
APPENDIX 1 PHOTOGRAPHS OF SET UP	72
APPENDIX 2 PHOTOGRAPHS OF EUT	74

This document is issued by the Company subject to its General Conditions of Service printed overleaf or available on request and accessible at www.sgs.com. Attention is drawn to the limitations of liability, indemnification, and Jurisdictional issued defined therein. Unless otherwise stated, the results shown in this test report refer only to the sample(s) tested. This document cannot be reproduced except in full, without prior approval of Company. Any unauthorized alteration, forgery or falsification of the content or appearance of this report is unlawful and offenders may be prosecuted to the fullest extent of the law. 此報告是遵循本公司訂定之通用服務條款所製作發放，請注意此條款列印於背面，亦可在www.sgs.com中查閱。將本公司之義務，免責，管轄權皆明確規範之。除非另有說明，此報告結果僅對檢驗之樣品負責。本報告未經本公司書面許可，不可部份複製。對本報告內容或外觀之任何未經授權之變更、偽造、竄改皆屬非法，違犯者將會被依法追訴。

1. GENERAL INFORMATION

General:

Product Name:	PDA Phone	
Brand Name:	hTC	
Model Name:	KAIS140	
Model Difference:	N/A	
Simple Hands-Free (SHF):	Mode No. G-EP-A404:, Supplier: MEC Mode No. CHM-311STV08002:, Supplier: COTRON	
Data Cable (USB):	1 cable, model: N/A	
Cigar Lighter Adaptor (CLA):	Model No.: CLM10D-050-R	
Power Supply:	3.7 Vdc re-chargeable battery or 5Vdc from AC/DC power Adaptor	
	Battery:	Model No.: KAIS160, Supplier: Dynapack, or Model No.: KAIS160, Supplier: Samsung
	Adapter:	Model: PSAA05A-050, Supplier: Phihong, or Model: ADP-5FH B,, Supplier: DELTA.

GSM and WCDMA:

Cellular Phone Standards:	GSM 850, 900, 1800 , 1900 and WCDMA Band IX Mobile Phone	
Frequency Range and Power:	GSM 850: 824MHz –849MHz	33 dBm
	GSM 1900: 1850MHz –1910MHz	30 dBm
	WCDMA Band IX: TX:1749.90MHz – 1784.9MHz	24 dBm
Hardware Version:	XA02	
Software Version:	25.64.40.01H	
IMEI:	35972801001035601	
Antenna Gain:	GSM: PIFA Antenna, 1.5dBi WCDMA: PIFA Antenna, 1.5dBi	

WLAN:

Frequency Range:	2412 – 2462 MHz
Channel number:	11 channels
Max. Output Power:	802.11b : 16.66 dBm (Peak) 802.11g : 14.51 dBm (Peak)
Modulation Technology:	DSSS, OFDM
Modulation type:	CCK, DQPSK, DBPSK for DSSS 64QAM, 16QAM, QPSK, BPSK for OFDM
Transition Rate:	802.11 b: 1/2/5.5/11 Mbps; 802.11 g: 6/9/12/18/24/36/48/54 Mbps
Antenna Designation:	PIFA Antenna, 1.50 dBi

The EUT is compliance with IEEE 802.11 b/g Standard.

Bluetooth:

Frequency Range:	2402 – 2480MHz
Channel number:	79 channels
Transmit Power:	-0.33 dBm (Peak)
Modulation type:	Frequency Hopping Spread Spectrum (GFSK) (FHSS) (4/πQPSK) (8QPSK)
Frequency Range:	2.402GHz – 2.480GHz
Dwell Time:	<= 0.4s
Operating Mode:	Point-to-Point
Antenna Designation:	PIFA Antenna, 1.50 dBi

The EUT is compliance with Bluetooth 2.0 + EDR Standard.

This test report applies for GSM/GPRS/EDGE 850, GSM/GPRS/EDGE 1900.

1.1 Related Submittal(s) / Grant (s)

This submittal(s) (test report) is intended for **FCC ID: NM8KSJ** filing to comply with Section Part 22 subpart H and Part 24 subpart E of the FCC CFR 47 Rules.

1.2 Test Methodology

Both conducted and radiated testing were performed according to the procedures document on TIA/EIA 603 and FCC CFR 47.1046, 2.1047, 2.1049, 2.1051, 2.1053, 2.1055 and 2.1057.

The Procedure of KDB941225 (SAR Measurement Procedures for 3G devices, WCDMA/HSDPA) was used for EUT and Base station setting.

1.3 Test Facility

The measurement facilities used to collect the 3m Radiated Emission and AC power line conducted data are located on the address of SGS Taiwan Ltd. Electronics & Communication Laboratory No. 134, Wu Kung Rd., Wuku Industrial Zone, Taipei Country, Taiwan which are constructed and calibrated to meet the FCC requirements in documents ANSI C63.4: 2003. FCC Registration Number are: 990257 and 236194, Canada Registration Number: 4620A-1

The 10 m Open Area Test Sites located on the address of SGS Taiwan Ltd. Electronics & Communication Laboratory No. 29, Pau-Tou-Tsuo Valley Chia-Pau Tsuen, Linkou Hsiang, Taipei county, which is constructed and calibrated to meet the CISPR 22/EN 55022 requirements. SGS Site No. 1(3 &10 meters) and FCC Registration Number: 94644.

1.4 Special Accessories

Not available for this EUT intended for grant.

1.5 Equipment Modifications

Not available for this EUT intended for grant.

2. SYSTEM TEST CONFIGURATION

2.1 EUT Configuration

The EUT configuration for testing is installed on RF field strength measurement to meet the Commissions requirement and operating in a manner which intends to maximize its emission characteristics in a continuous normal application.

2.2 EUT Exercise

The EUT (Transmitter) was operated in the engineering mode to fix the Tx frequency which was for the purpose of the measurements.

2.3 Test Procedure

2.3.1 Conducted Emissions

The EUT is placed on a turn table which is 0.8 m above ground plane. According to the requirements in Section 7 and 13 of ANSI C63.4-2003. Conducted emissions from the EUT measured in the frequency range between 0.15 MHz and 30MHz using CISPR Quasi-Peak and Average detector mode.

2.3.2 Radiated Emissions

The EUT is placed on a turn table which is 1.0 m above ground plane. The turn table shall rotate 360 degrees to determine the position of maximum emission level. EUT is set 3m away from the receiving antenna which varied from 1m to 4m to find out the highest emission. And also, each emission was to be maximized by changing the polarization of receiving antenna both horizontal and vertical. In order to find out the max. emission, the relative positions of this hand-held transmitter (EUT) was rotated through three orthogonal axes according to the requirements in Section 8 and 13 of ANSI C63.4-2003.

2.4 Configuration of Tested System

Fig. 2-1 Configuration of Tested System (Fixed Channel)

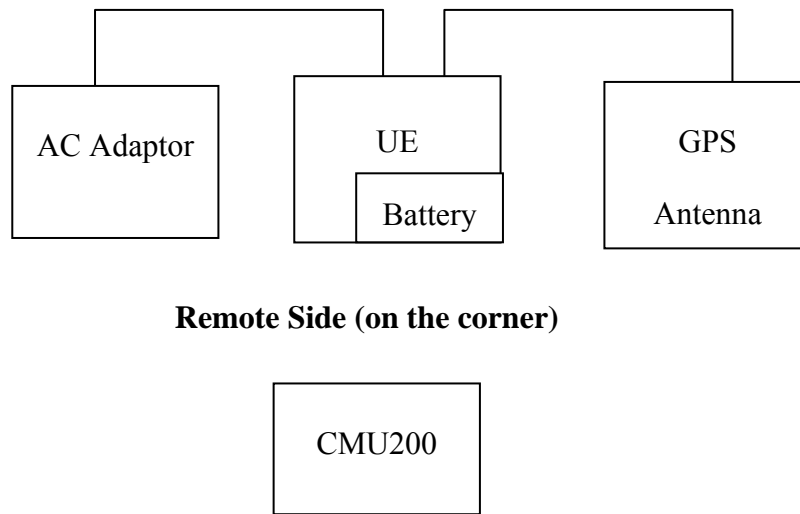

Table 2-1 Equipment Used in Tested System

Item	Equipment	Mfr/Brand	Model/ Type No.	Series No.	Data Cable	Power Cord
1.	Universal Radio Communication Tester	R&S	CMU200	102189	shielded	Un-shielded

3. SUMMARY OF TEST RESULTS

FCC Rules	Description Of Test	Result
§2.1046(a) §22.913(a) §24.232(a)	RF Power Output	Compliant
§2.1046(a) §22.913(a) §24.232(a)	ERP/ EIRP measurement	Compliant
§2.1049(h)	99% Occupied Bandwidth	Compliant
§2.1051 §22.917(a) §24.238(a)	Out of Band Emissions at Antenna Terminals and Band Edge	Compliant
§2.1053 §22.917(a) §24.238(a)	Field Strength of Spurious Radiation	Compliant
§2.1055(a)(1)(b)	Frequency Stability vs. Temperature	Compliant
§2.1055(d)(1)(2)	Frequency Stability vs. Voltage	Compliant
§15.107;§15.207	AC Power Line Conducted Emission	Compliant

4. DESCRIPTION OF TEST MODES

The EUT has been tested under operating condition.

EUT staying in continuous transmitting mode. Channel Low, Mid and High for each type band with rated data rate were chosen for full testing.

The field strength of spurious radiation emission was measured as EUT stand-up position (E1 mode) and lie down position (E1, E2 mode) for both GSM/GPRS with all power adaptors, ear-phone and Data cable. The output power of 850 and 1900 MHz EDGE modes have 3 dB lower than GSM mode's. Therefore the worst-case of E2 position for GSM 850 band, E1 position for GSM 1900 band were reported

5. RF POWER OUTPUT MEASUREMENT

5.1 Standard Applicable

According to FCC §2.1046.

FCC 22.913(a) Mobile station are limited to 7W.

FCC 24.232(b) Mobile station are limited to 2W.

5.2 Test Set-up:

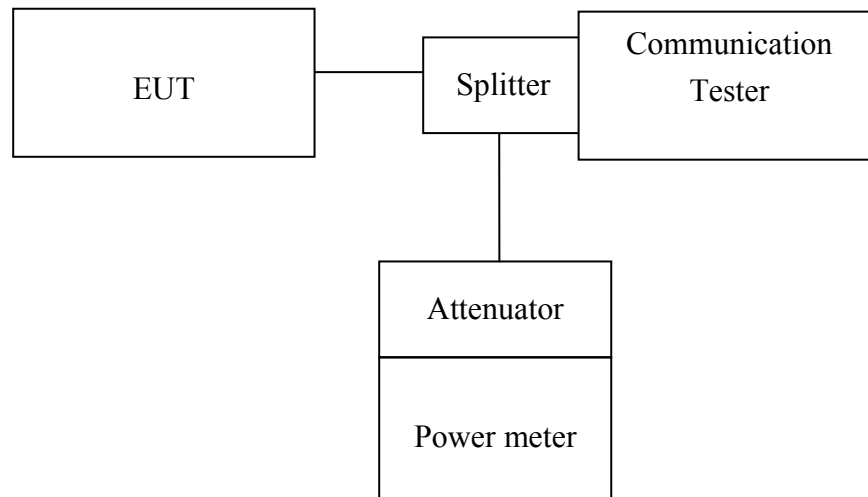

Note: Measurement setup for testing on Antenna connector

5.3 Measurement Procedure

The transmitter output was connected to a calibrated attenuator, the other end of which was connected to a power meter. Transmitter output was read off the power meter in dBm. The power output at the transmitter antenna port was determined by adding the value of the attenuator to the power meter reading. The Procedure of KDB941225 (SAR Measurement Procedures for 3G devices, WCDMA/HSDPA) was used for EUT and Base station setting.

5.4 Measurement Equipment Used:

Conducted Emission Test Site					
EQUIPMENT TYPE	MFR	MODEL NUMBER	SERIAL NUMBER	LAST CAL.	CAL DUE.
Spectrum Analyzer	Agilent	E4446A	MY43360126	04/27/2007	04/27/2008
Spectrum Analyzer	Agilent	E7405A	US41160416	07/04/2007	07/03/2008
Spectrum Analyzer	R&S	FSP 40	100034	01/05/2008	01/04/2009
Communication Test	R&S	SMU200	N/A	N/A	N/A
Power Sensor	Anritsu	MA2490A	31431	07/07/2007	07/06/2008
Power Meter	Anritsu	ML2487A	6K00002070	07/07/2007	07/06/2008
Temperature Chamber	TERCHY	MHG-120LF	911009	04/26/2007	04/25/2008
Low Loss Cable	HUBER+SUHNER	SUCOFLEX 104PEA	N/A	N/A	N/A
Attenuator	Mini-Circuit	BW-S10W5	N/A	07/05/2007	07/04/2008
Attenuator	Mini-Circuit	BW-S6W5	N/A	07/05/2007	07/04/2008
Splitter	Agilent	11636B	51728	07/05/2007	07/04/2008
DC Power Supply	Agilent	6038A	2929A-07548	06/27/2007	06/26/2008

This document is issued by the Company subject to its General Conditions of Service printed overleaf or available on request and accessible at www.sgs.com. Attention is drawn to the limitations of liability, indemnification, and Jurisdictional issued defined therein. Unless otherwise stated, the results shown in this test report refer only to the sample(s) tested. This document cannot be reproduced except in full, without prior approval of Company. Any unauthorized alteration, forgery or falsification of the content or appearance of this report is unlawful and offenders may be prosecuted to the fullest extent of the law. 此報告是遵循本公司訂定之通用服務條款所製作發放，請注意此條款列印於背面，亦可在www.sgs.com中查閱。將本公司之義務，免責，管轄權皆明確規範之。除非另有說明，此報告結果僅對檢驗之樣品負責。本報告未經本公司書面許可，不可部份複製。對本報告內容或外觀之任何未經授權之變更、偽造、竄改皆屬非法，違犯者將會被依法追訴。

5.5 Measurement Result

EUT Mode	Frequency (MHz)	CH	Power meter Reading (dBm)	Path Loss (dB)	Peak Power (dBm)
GSM 850	824.20	128	33.22	0.00	33.22
	836.60	190	33.27	0.00	33.27
	848.80	251	33.13	0.00	33.13

* Offset 6.5dB

EUT Mode	Frequency (MHz)	CH	Power Meter Reading (dBm)	Path Loss (dB)	Peak Power (dBm)
PCS 1900	1850.20	512	29.24	0.00	29.24
	1880.00	661	29	0.00	29.00
	1909.80	810	29.01	0.00	29.01

* Offset 6.7dB

EUT Mode	Frequency (MHz)	CH	Power meter Reading (dBm)	Path Loss (dB)	Peak Power (dBm)
EDGE 850	824.20	128	25.93	0.00	25.93
	836.60	190	26.04	0.00	26.04
	848.80	251	26.12	0.00	26.12

* Offset 0.5dB

EUT Mode	Frequency (MHz)	CH	Power Meter Reading (dBm)	Path Loss (dB)	Peak Power (dBm)
EDGE 1900	1850.20	512	24.01	0.00	24.01
	1880.00	661	24.25	0.00	24.25
	1909.80	810	24.06	0.00	24.06

* Offset 0.5dB

This document is issued by the Company subject to its General Conditions of Service printed overleaf or available on request and accessible at www.sgs.com. Attention is drawn to the limitations of liability, indemnification, and Jurisdictional issued defined therein. Unless otherwise stated, the results shown in this test report refer only to the sample(s) tested. This document cannot be reproduced except in full, without prior approval of Company. Any unauthorized alteration, forgery or falsification of the content or appearance of this report is unlawful and offenders may be prosecuted to the fullest extent of the law. 此報告是遵循本公司訂定之通用服務條款所製作發放，請注意此條款列印於背面，亦可在www.sgs.com中查閱。將本公司之義務，免責，管轄權皆明確規範之。除非另有說明，此報告結果僅對檢驗之樣品負責。本報告未經本公司書面許可，不可部份複製。對本報告內容或外觀之任何未經授權之變更、偽造、竄改皆屬非法，違犯者將會被依法追訴。

6. ERP, EIRP MEASUREMENT

6.1 Standard Applicable

According to FCC §2.1046

FCC 22.913(a) Mobile station are limited to 7W ERP.

FCC 24.232(b) Mobile station are limited to 2W EIRP.

6.2 Test SET-UP (Block Diagram of Configuration)

(A) Radiated Emission Test Set-Up, Frequency Below 1000MHz

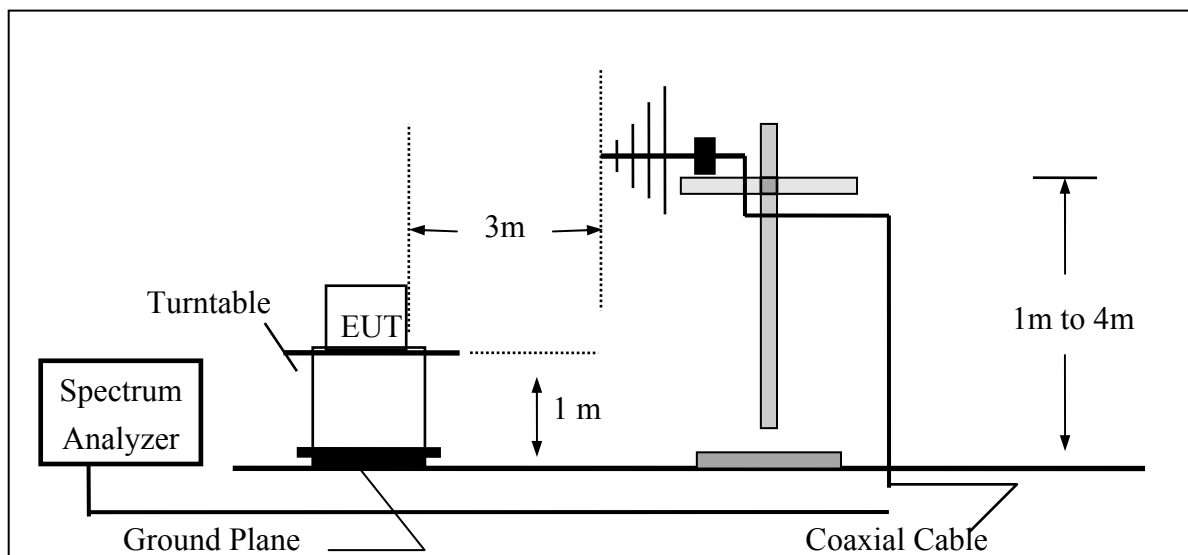

This document is issued by the Company subject to its General Conditions of Service printed overleaf or available on request and accessible at www.sgs.com. Attention is drawn to the limitations of liability, indemnification, and Jurisdictional issued defined therein. Unless otherwise stated, the results shown in this test report refer only to the sample(s) tested. This document cannot be reproduced except in full, without prior approval of Company. Any unauthorized alteration, forgery or falsification of the content or appearance of this report is unlawful and offenders may be prosecuted to the fullest extent of the law. 此報告是遵循本公司訂定之通用服務條款所製作發放，請注意此條款列印於背面，亦可在www.sgs.com中查閱。將本公司之義務，免責，管轄權皆明確規範之。除非另有說明，此報告結果僅對檢驗之樣品負責。本報告未經本公司書面許可，不可部份複製。對本報告內容或外觀之任何未經授權之變更、偽造、竄改皆屬非法，違犯者將會被依法追訴。

(B) Radiated Emission Test Set-UP Frequency Over 1 GHz

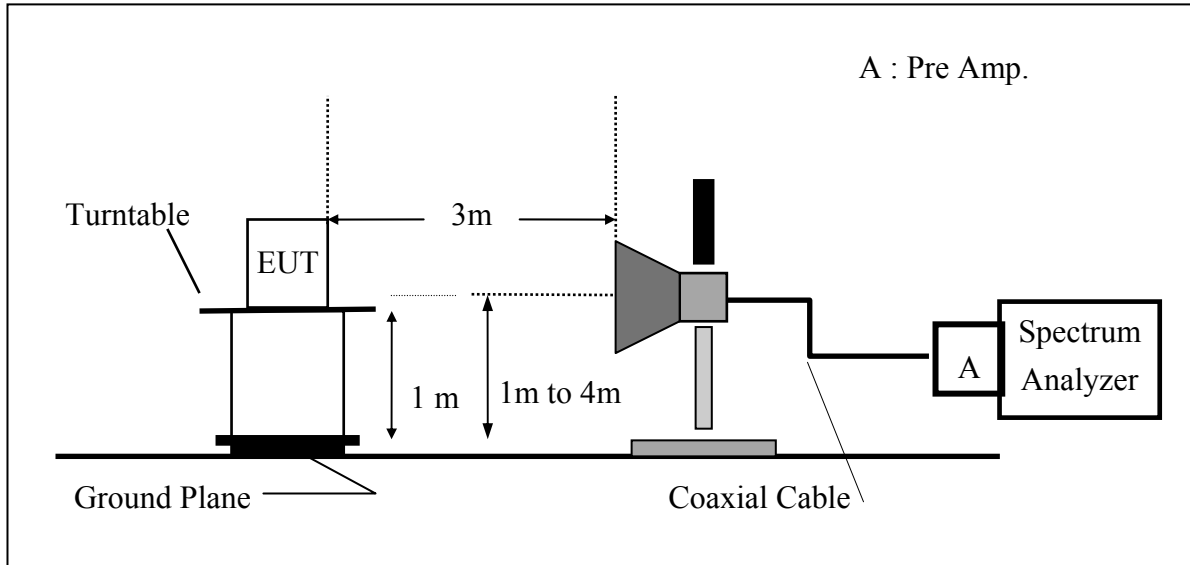

(C) Substituted Method Test Set-UP

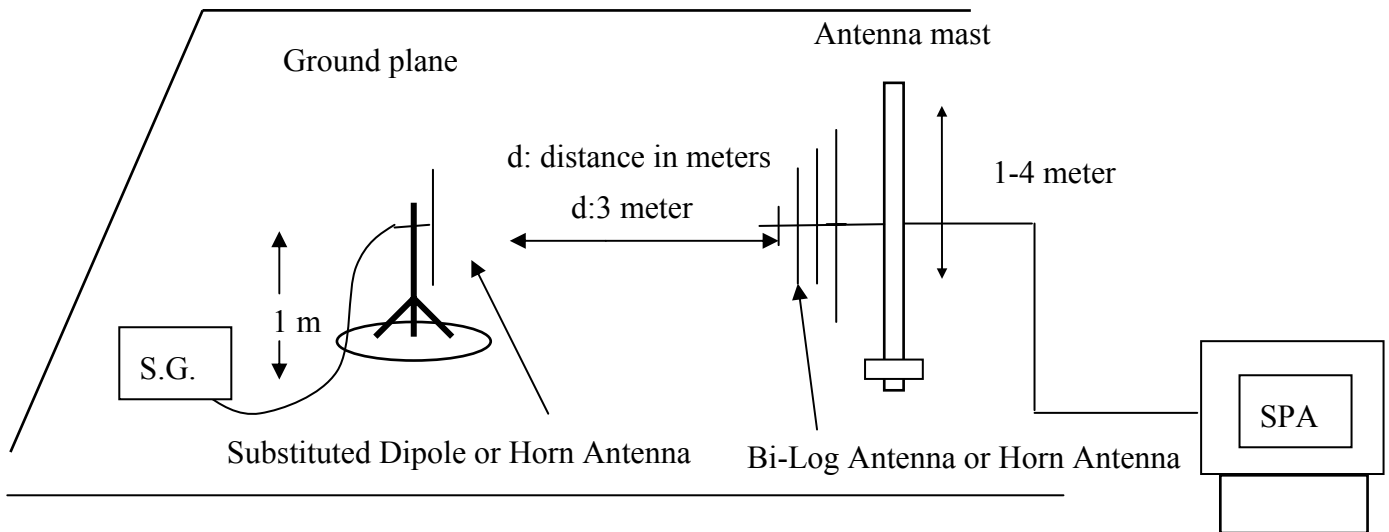

This document is issued by the Company subject to its General Conditions of Service printed overleaf or available on request and accessible at www.sgs.com. Attention is drawn to the limitations of liability, indemnification, and Jurisdictional issued defined therein. Unless otherwise stated, the results shown in this test report refer only to the sample(s) tested. This document cannot be reproduced except in full, without prior approval of Company. Any unauthorized alteration, forgery or falsification of the content or appearance of this report is unlawful and offenders may be prosecuted to the fullest extent of the law. 此報告是遵循本公司訂定之通用服務條款所製作發放，請注意此條款列印於背面，亦可在www.sgs.com中查閱。將本公司之義務，免責，管轄權皆明確規範之。除非另有說明，此報告結果僅對檢驗之樣品負責。本報告未經本公司書面許可，不可部份複製。對本報告內容或外觀之任何未經授權之變更、偽造、竄改皆屬非法，違犯者將會被依法追訴。

6.3 Measurement Procedure

The EUT was placed on an non-conductive turntable using a non-conductive support. The radiated emission at the fundamental frequency was measured at 3 m with a test antenna and EMI spectrum analyzer.

During the measurement, the EUT was communication with the station. The highest emission was recorded with the rotation of the turntable and the lowering of the test antenna from 4m to 1m. The reading was recorded and the field strength (E in dBuV/m) was calculated.

ERP in frequency band 824.2 –848.8MHz were measured using a substitution method. The EUT was replaced by dipole antenna connected, the S.G. output was recorded and ERP was calculated as follows:

EIRP in frequency band 1850.2 –1909.8MHz were measured using a substitution method. The EUT was replaced by or horn antenna connected, the S.G. output was recorded and EIRP was calculated as follows:

$$\text{ERP} = \text{S.G. output (dBm)} + \text{Antenna Gain (dBd)} - \text{Cable Loss (dB)}$$

$$\text{EIRP} = \text{S.G. output (dBm)} + \text{Antenna Gain (dBi)} - \text{Cable Loss (dB)}$$

The Procedure of KDB941225 (SAR Measurement Procedures for 3G devices, WCDMA/HSDPA) was used for EUT and Base station setting.

6.4 Measurement Equipment Used:

EQUIPMENT TYPE	MFR	MODEL NUMBER	SERIAL NUMBER	LAST CAL.	CAL DUE.
Spectrum Analyzer	Agilent	E4446A	MY43360126	04/27/2007	04/26/2008
Spectrum Analyzer	Agilent	E7405A	US41160416	07/04/2007	07/03/2008
Spectrum Analyzer	R&S	FSP 40	100034	11/09/2007	11/10/2008
Communication Test	R&S	SMU200	N/A	N/A	N/A
Bi-log Antenna	SCHWAZBECK	VULB9160	3224	11/14/2007	11/13/2008
Horn antenna	SCHWAZBECK	BBHA 9120D	309/320	08/16/2007	08/15/2008
Pre-Amplifier	HP	8447D	2944A09469	07/19/2007	07/18/2008
Pre-Amplifier	HP	8494B	3008A00578	02/26/2007	02/25/2008
Signal Generator	R&S	SMR40	100210	02/09/2007	02/10/2008
Turn Table	HD	DT420	N/A	N.C.R	N.C.R
Antenna Tower	HD	MA240-N	240/657	N.C.R	N.C.R
Controller	HD	HD100	N/A	N.C.R	N.C.R
Low Loss Cable	HUBER+SUHNER	SUCOFLEX 104PEA-10M	10m	10/09/2007	10/08/2008
Low Loss Cable	HUBER+SUHNER	SUCOFLEX 104PEA-3M	3m	10/09/2007	10/08/2008
Low Loss Cable	HUBER+SUHNER	SUCOFLEX 104PEA-0.5M	0.5m	10/09/2007	10/08/2008
Site NSA	SGS	966 chamber	N/A	11/17/2007	11/16/2008
Attenuator	Mini-Circuit	BW-S10W5	N/A	09/23/2007	09/22/2008
Dipole Antenna	SCHWAZBECK	VHAP	908/909	06/09/2007	06/10/2008
Dipole Antenna	SCHWAZBECK	UHAP	891/892	06/09/2007	06/10/2008
Horn antenna	SCHWAZBECK	BBHA 9120D	N/A	08/16/2007	08/15/2008

This document is issued by the Company subject to its General Conditions of Service printed overleaf or available on request and accessible at www.sgs.com. Attention is drawn to the limitations of liability, indemnification, and Jurisdictional issued defined therein. Unless otherwise stated, the results shown in this test report refer only to the sample(s) tested. This document cannot be reproduced except in full, without prior approval of Company. Any unauthorized alteration, forgery or falsification of the content or appearance of this report is unlawful and offenders may be prosecuted to the fullest extent of the law. 此報告是遵循本公司訂定之通用服務條款所製作發放，請注意此條款列印於背面，亦可在www.sgs.com中查閱。將本公司之義務，免責，管轄權皆明確規範之。除非另有說明，此報告結果僅對檢驗之樣品負責。本報告未經本公司書面許可，不可部份複製。對本報告內容或外觀之任何未經授權之變更、偽造、竄改皆屬非法，違犯者將會被依法追訴。

6.5 Measurement Result

EUT Mode	Frequency (MHz)	CH	EUT Pol.	Antenna Pol.	SPA Reading (dBuV)	S.G. Output (dBm)	Antenna Gain (dBd)	Cable Loss (dB)	ERP (dBm)	Limit (dBm)
GSM 850	824.20	128	H	V	120.67	33.35	-7.87	3.64	21.83	38.45
				H	127.32	39.66	-7.87	3.64	28.15	38.45
			E1	V	127.36	40.04	-7.87	3.64	28.52	38.45
				H	117.85	30.19	-7.87	3.64	18.68	38.45
			E2	V	120.74	33.42	-7.87	3.64	21.90	38.45
				H	128.70	41.04	-7.87	3.64	29.53	38.45
	836.60	190	H	V	120.65	33.62	-7.88	3.70	22.05	38.45
				H	126.42	39.08	-7.88	3.70	27.51	38.45
			E1	V	126.60	39.57	-7.88	3.70	28.00	38.45
				H	118.27	30.93	-7.88	3.70	19.36	38.45
			E2	V	120.46	33.43	-7.88	3.70	21.86	38.45
				H	127.91	40.57	-7.88	3.70	29.00	38.45
	848.80	251	H	V	119.50	32.76	-7.88	3.75	21.13	38.45
				H	125.76	38.74	-7.88	3.75	27.11	38.45
			E1	V	126.21	39.47	-7.88	3.75	27.84	38.45
				H	118.04	31.02	-7.88	3.75	19.39	38.45
			E2	V	119.93	33.19	-7.88	3.75	21.56	38.45
				H	126.84	39.82	-7.88	3.75	28.19	38.45

Remark :

- (1) The RBW,VBW of SPA for frequency
 Below 1GHz was RBW=100 KHz, VBW=300KHz,
 Above 1GHz was RBW= 1MHz , VBW= 3MHz

6.6 Measurement Result

EUT Mode	Frequency (MHz)	CH	EUT Pol.	Antenna Pol.	SPA Reading (dBuV)	S.G. Output (dBm)	Antenna Gain (dBi)	Cable Loss (dB)	EIRP (dBm)	Limit (dBm)
PCS 1900	1850.20	512	H	V	116.11	9.15	9.90	5.41	13.64	33.00
				H	124.52	17.63	9.90	5.41	22.12	33.00
			E1	V	126.89	19.93	9.90	5.41	24.42	33.00
				H	121.92	15.03	9.90	5.41	19.52	33.00
			E2	V	121.88	14.92	9.90	5.41	19.41	33.00
				H	124.72	17.83	9.90	5.84	21.89	33.00
	1880.00	661	H	V	116.85	9.90	9.99	5.46	14.43	33.00
				H	124.41	17.54	9.99	5.46	22.07	33.00
			E1	V	126.65	19.70	9.99	5.46	24.23	33.00
				H	121.61	14.74	9.99	5.46	19.27	33.00
			E2	V	121.71	14.76	9.99	5.46	19.29	33.00
				H	124.84	17.97	9.99	5.46	22.50	33.00
	1909.80	810	H	V	117.07	10.13	10.08	5.51	14.70	33.00
				H	124.58	17.73	10.08	5.51	22.29	33.00
			E1	V	125.48	18.54	10.08	5.51	23.11	33.00
				H	122.77	15.92	10.08	5.51	20.48	33.00
			E2	V	121.08	14.14	10.08	5.51	18.71	33.00
				H	125.00	18.15	10.08	5.51	22.71	33.00

Remark :

- (1) The RBW,VBW of SPA for frequency
 Below 1GHz was RBW=100 KHz, VBW=300KHz,
 Above 1GHz was RBW= 1MHz , VBW= 3MHz

7. 99% OCCUPIED BANDWIDTH MEASUREMENT

7.1 Standard Applicable

According to §FCC 2.1049.

7.2 Test Set-up:

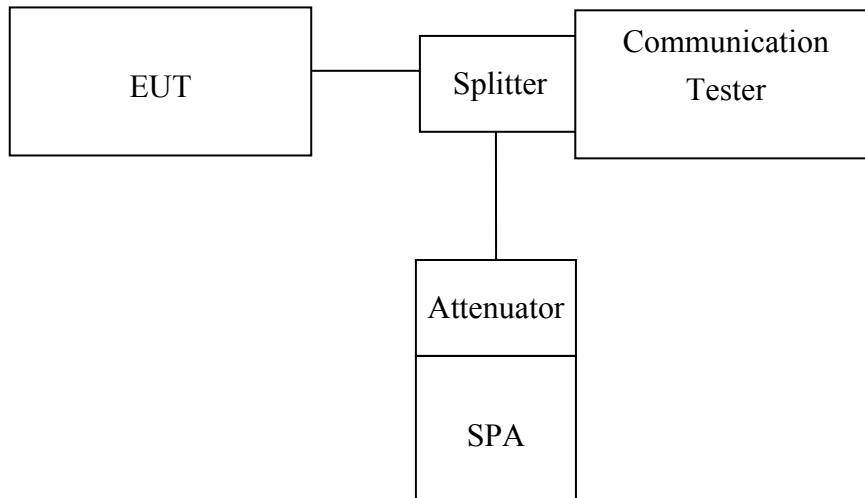

Note: Measurement setup for testing on Antenna connector

7.3 Measurement Procedure

The EUT's output RF connector was connected with a short cable to the spectrum analyzer, RBW (10/30KHz) was set to about 1% of emission BW, VBW= 3 times RBW(30/100KHz), -26dBc display line was placed on the screen (or 99% bandwidth), the occupied bandwidth is the delta frequency between the two points where the display line intersects the signal trace.

7.4 Measurement Equipment Used:

Conducted Emission Test Site					
EQUIPMENT TYPE	MFR	MODEL NUMBER	SERIAL NUMBER	LAST CAL.	CAL DUE.
Spectrum Analyzer	Agilent	E4446A	MY43360126	04/27/2007	04/27/2008
Spectrum Analyzer	Agilent	E7405A	US41160416	07/04/2007	07/03/2008
Spectrum Analyzer	R&S	FSP 40	100034	01/05/2008	01/04/2009
Communication Test	R&S	SMU200	N/A	N/A	N/A
Power Sensor	Anritsu	MA2490A	31431	07/07/2007	07/06/2008
Power Meter	Anritsu	ML2487A	6K00002070	07/07/2007	07/06/2008
Temperature Chamber	TERCHY	MHG-120LF	911009	04/26/2007	04/25/2008
Low Loss Cable	HUBER+SUHNER	SUCOFLEX 104PEA	N/A	N/A	N/A
Attenuator	Mini-Circuit	BW-S10W5	N/A	07/05/2007	07/04/2008
Attenuator	Mini-Circuit	BW-S6W5	N/A	07/05/2007	07/04/2008
Splitter	Agilent	11636B	51728	07/05/2007	07/04/2008
DC Power Supply	Agilent	6038A	2929A-07548	06/27/2007	06/26/2008

This document is issued by the Company subject to its General Conditions of Service printed overleaf or available on request and accessible at www.sgs.com. Attention is drawn to the limitations of liability, indemnification, and Jurisdictional issued defined therein. Unless otherwise stated, the results shown in this test report refer only to the sample(s) tested. This document cannot be reproduced except in full, without prior approval of Company. Any unauthorized alteration, forgery or falsification of the content or appearance of this report is unlawful and offenders may be prosecuted to the fullest extent of the law. 此報告是遵循本公司訂定之通用服務條款所製作發放，請注意此條款列印於背面，亦可在www.sgs.com中查閱。將本公司之義務，免責，管轄權皆明確規範之。除非另有說明，此報告結果僅對檢驗之樣品負責。本報告未經本公司書面許可，不可部份複製。對本報告內容或外觀之任何未經授權之變更、偽造、竄改皆屬非法，違犯者將會被依法追訴。

7.5 Measurement Result:

EUT Mode	Frequency (MHz)	CH	99% Bandwidth (MHz)
GSM 850	824.20	128	0.2540
	836.60	190	0.2430
	848.80	251	0.2470

EUT Mode	Frequency (MHz)	CH	99% Bandwidth (MHz)
PCS 1900	1850.20	512	0.2450
	1880.00	661	0.2450
	1909.80	810	0.2450

EUT Mode	Frequency (MHz)	CH	99% Bandwidth (MHz)
EDGE 850	824.20	128	0.2430
	836.60	190	0.2470
	848.80	251	0.2430

EUT Mode	Frequency (MHz)	CH	99% Bandwidth (MHz)
EDGE 1900	1850.20	512	0.2440
	1880.00	661	0.2440
	1909.80	810	0.2440

This document is issued by the Company subject to its General Conditions of Service printed overleaf or available on request and accessible at www.sgs.com. Attention is drawn to the limitations of liability, indemnification, and Jurisdictional issued defined therein. Unless otherwise stated, the results shown in this test report refer only to the sample(s) tested. This document cannot be reproduced except in full, without prior approval of Company. Any unauthorized alteration, forgery or falsification of the content or appearance of this report is unlawful and offenders may be prosecuted to the fullest extent of the law. 此報告是遵循本公司訂定之通用服務條款所製作發放，請注意此條款列印於背面，亦可在www.sgs.com中查閱。將本公司之義務，免責，管轄權皆明確規範之。除非另有說明，此報告結果僅對檢驗之樣品負責。本報告未經本公司書面許可，不可部份複製。對本報告內容或外觀之任何未經授權之變更、偽造、竄改皆屬非法，違犯者將會被依法追訴。

Figure 7-1: GSM Channel Low

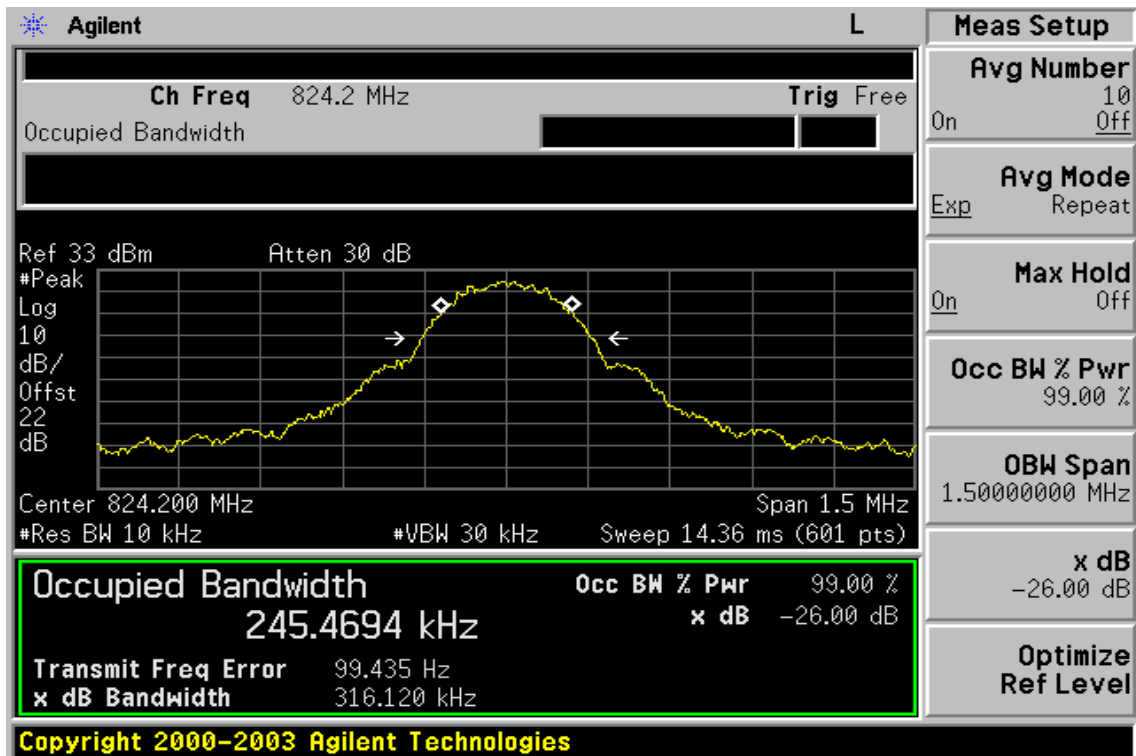
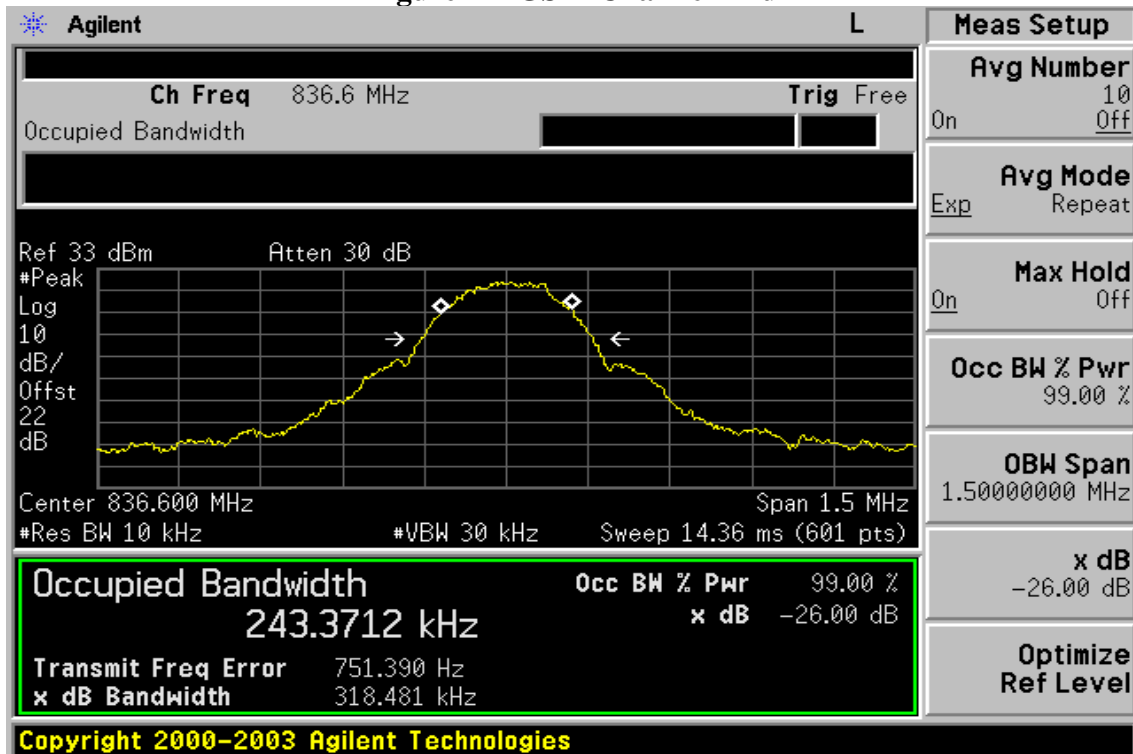

Figure 7-2 GSM Channel Mid



This document is issued by the Company subject to its General Conditions of Service printed overleaf or available on request and accessible at www.sgs.com. Attention is drawn to the limitations of liability, indemnification, and Jurisdictional issued defined therein. Unless otherwise stated, the results shown in this test report refer only to the sample(s) tested. This document cannot be reproduced except in full, without prior approval of Company. Any unauthorized alteration, forgery or falsification of the content or appearance of this report is unlawful and offenders may be prosecuted to the fullest extent of the law. 此報告是遵循本公司訂定之通用服務條款所製作發放，請注意此條款列印於背面，亦可在www.sgs.com中查閱。將本公司之義務，免責，管轄權皆明確規範之。除非另有說明，此報告結果僅對檢驗之樣品負責。本報告未經本公司書面許可，不可部份複製。對本報告內容或外觀之任何未經授權之變更、偽造、竄改皆屬非法，違犯者將會被依法追訴。

Figure 7-3: GSM Channel High

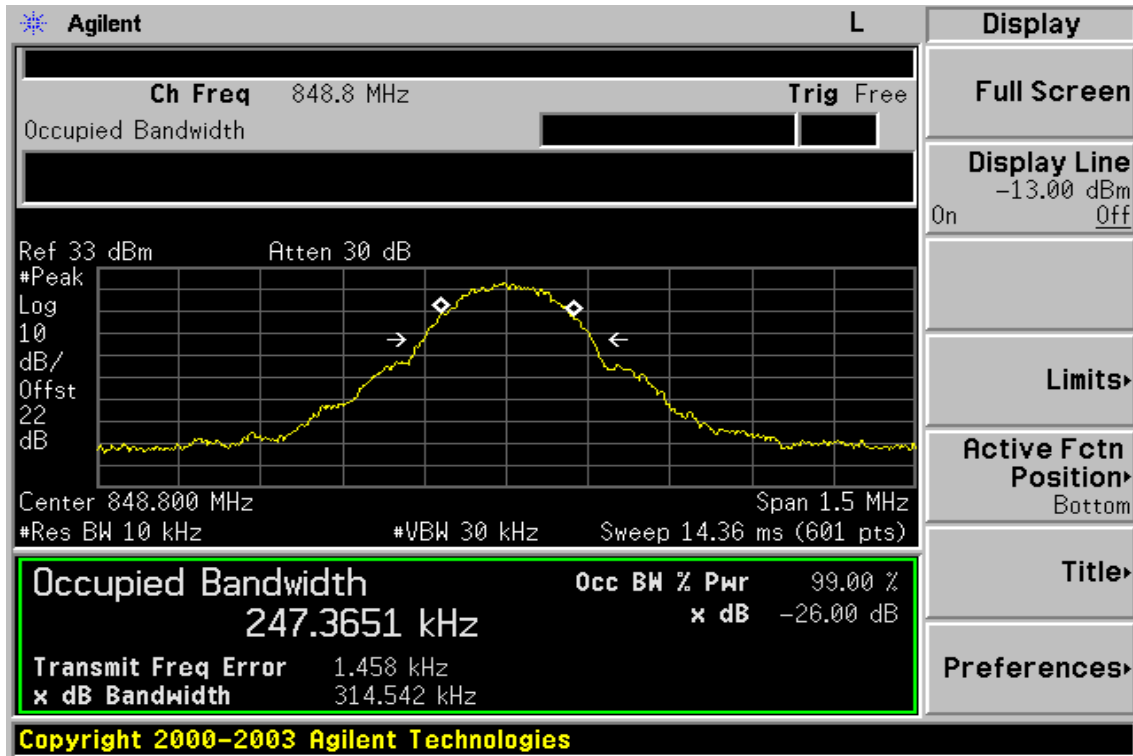
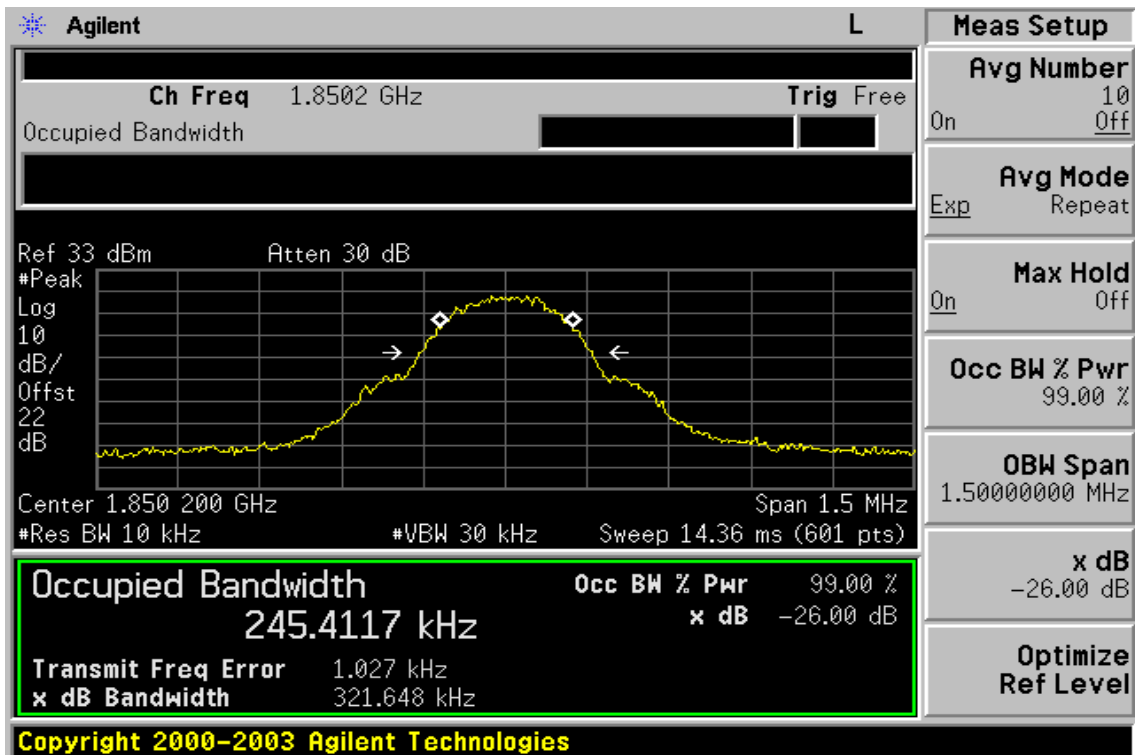

Figure 7-4: PCS Channel Low



This document is issued by the Company subject to its General Conditions of Service printed overleaf or available on request and accessible at www.sgs.com. Attention is drawn to the limitations of liability, indemnification, and Jurisdictional issued defined therein. Unless otherwise stated, the results shown in this test report refer only to the sample(s) tested. This document cannot be reproduced except in full, without prior approval of Company. Any unauthorized alteration, forgery or falsification of the content or appearance of this report is unlawful and offenders may be prosecuted to the fullest extent of the law. 此報告是遵循本公司訂定之通用服務條款所製作發放，請注意此條款列印於背面，亦可在www.sgs.com中查閱。將本公司之義務，免責，管轄權皆明確規範之。除非另有說明，此報告結果僅對檢驗之樣品負責。本報告未經本公司書面許可，不可部份複製。對本報告內容或外觀之任何未經授權之變更、偽造、竄改皆屬非法，違犯者將會被依法追訴。

Figure 7-5 PCS Channel Mid

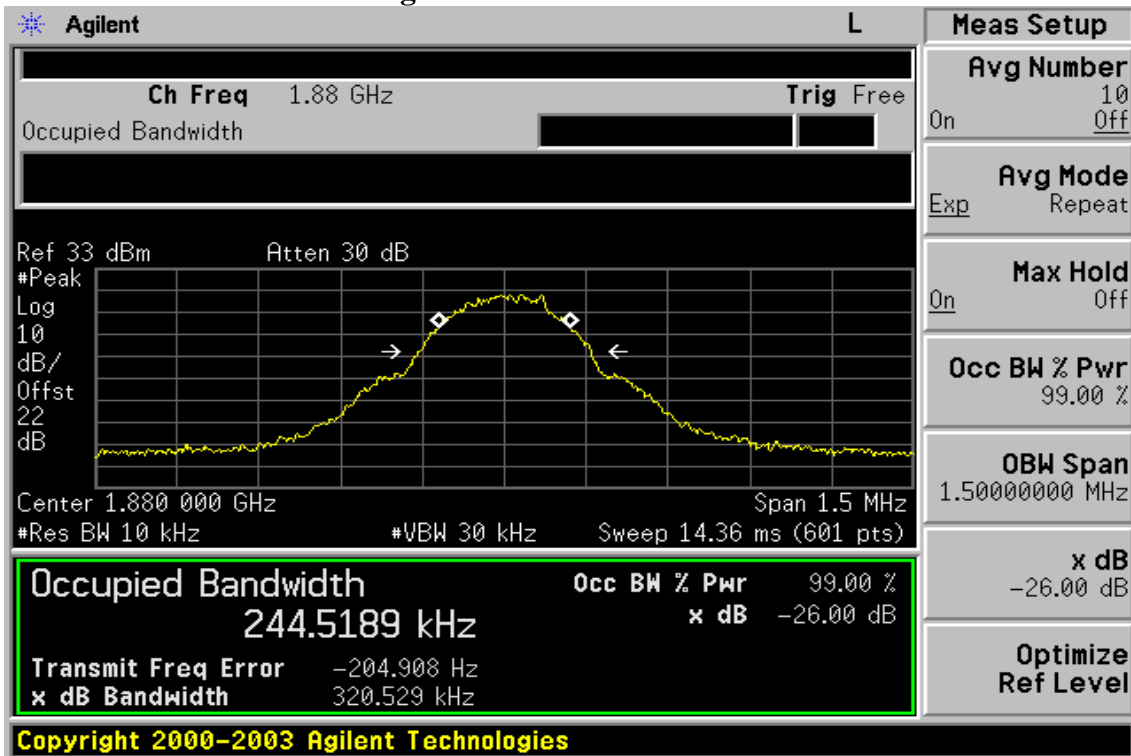
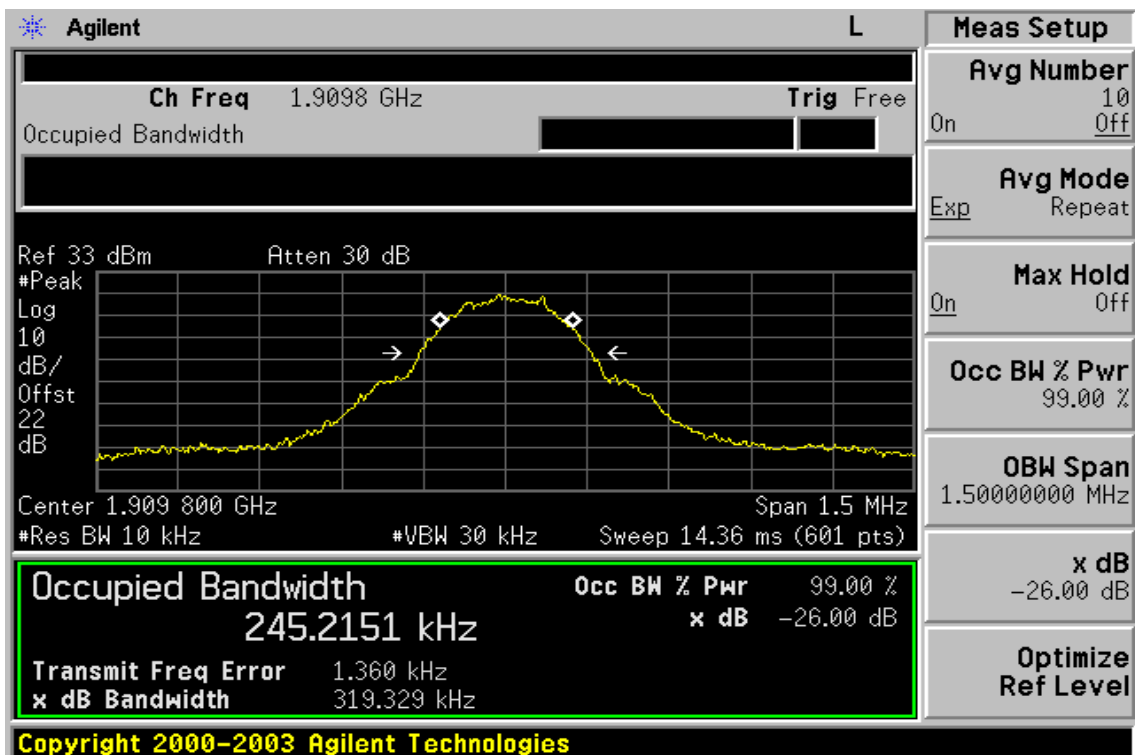

Figure 7-6: PCS Channel High



This document is issued by the Company subject to its General Conditions of Service printed overleaf or available on request and accessible at www.sgs.com. Attention is drawn to the limitations of liability, indemnification, and Jurisdictional issued defined therein. Unless otherwise stated, the results shown in this test report refer only to the sample(s) tested. This document cannot be reproduced except in full, without prior approval of Company. Any unauthorized alteration, forgery or falsification of the content or appearance of this report is unlawful and offenders may be prosecuted to the fullest extent of the law. 此報告是遵循本公司訂定之通用服務條款所製作發放，請注意此條款列印於背面，亦可在www.sgs.com中查閱。將本公司之義務，免責，管轄權皆明確規範之。除非另有說明，此報告結果僅對檢驗之樣品負責。本報告未經本公司書面許可，不可部份複製。對本報告內容或外觀之任何未經授權之變更、偽造、竄改皆屬非法，違犯者將會被依法追訴。

Figure 7-7: EDGE 850 Channel Low

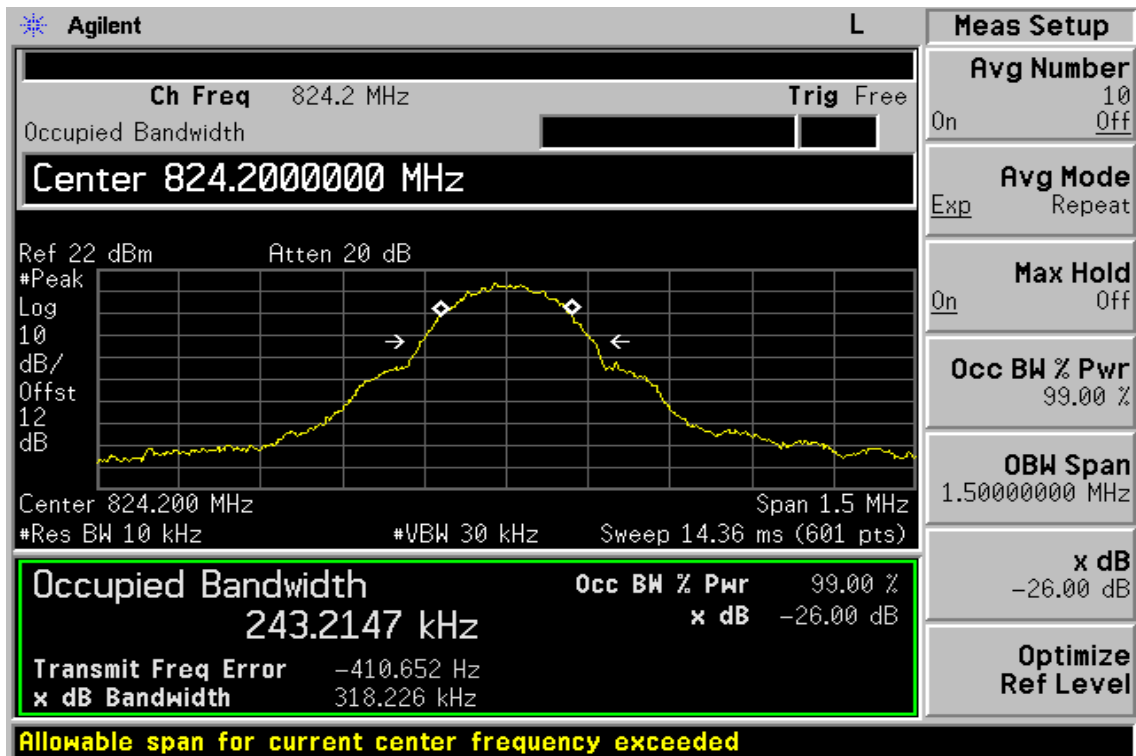
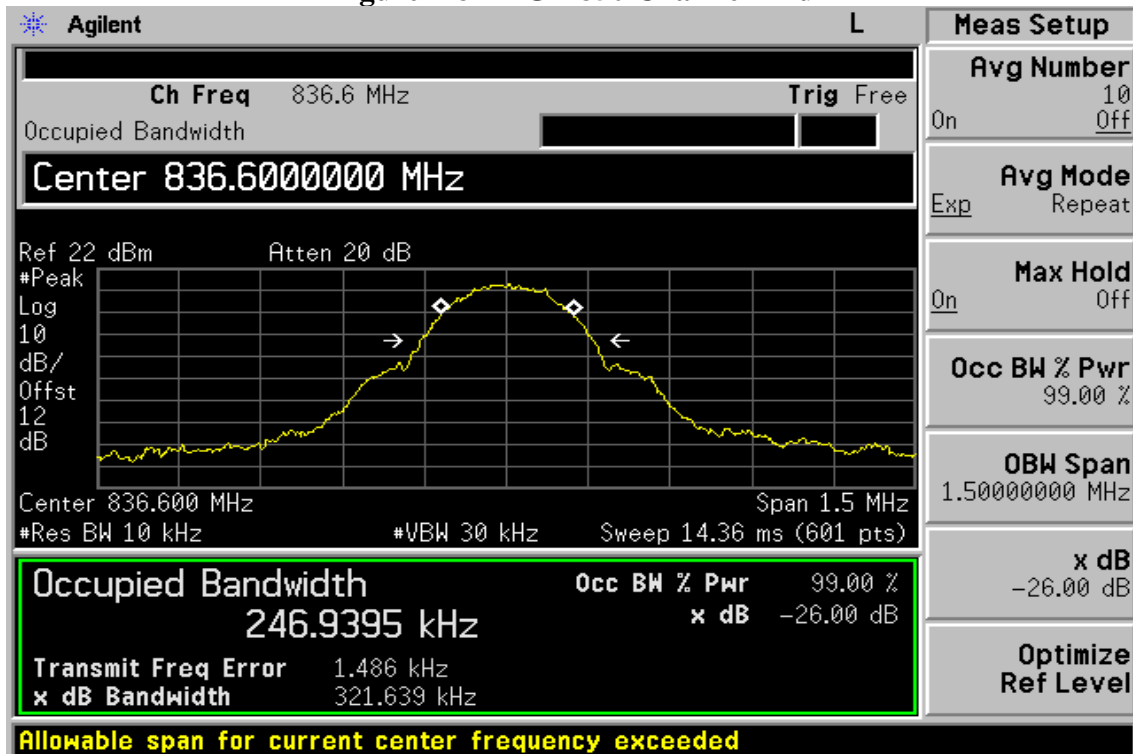

Figure 7-8 EDGE 850 Channel Mid



This document is issued by the Company subject to its General Conditions of Service printed overleaf or available on request and accessible at www.sgs.com. Attention is drawn to the limitations of liability, indemnification, and Jurisdictional issued defined therein. Unless otherwise stated, the results shown in this test report refer only to the sample(s) tested. This document cannot be reproduced except in full, without prior approval of Company. Any unauthorized alteration, forgery or falsification of the content or appearance of this report is unlawful and offenders may be prosecuted to the fullest extent of the law. 此報告是遵循本公司訂定之通用服務條款所製作發放，請注意此條款列印於背面，亦可在www.sgs.com中查閱。將本公司之義務，免責，管轄權皆明確規範之。除非另有說明，此報告結果僅對檢驗之樣品負責。本報告未經本公司書面許可，不可部份複製。對本報告內容或外觀之任何未經授權之變更、偽造、竄改皆屬非法，違犯者將會被依法追訴。

Figure 7-9: EDGE 850 Channel High

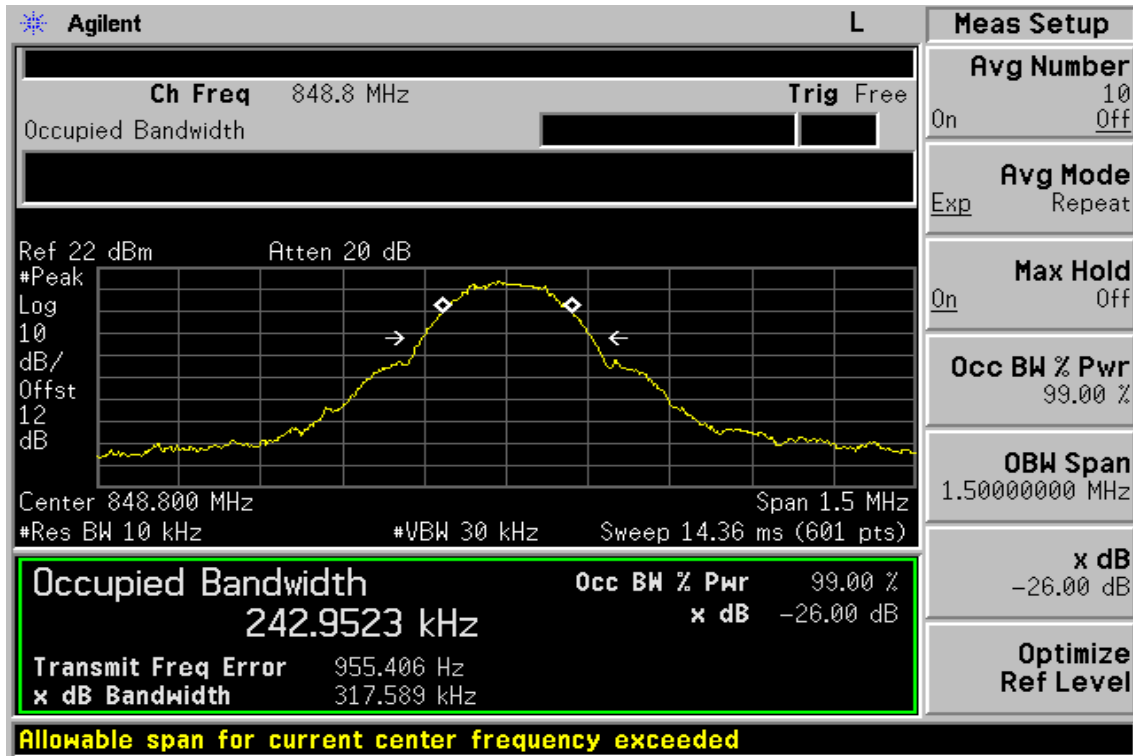
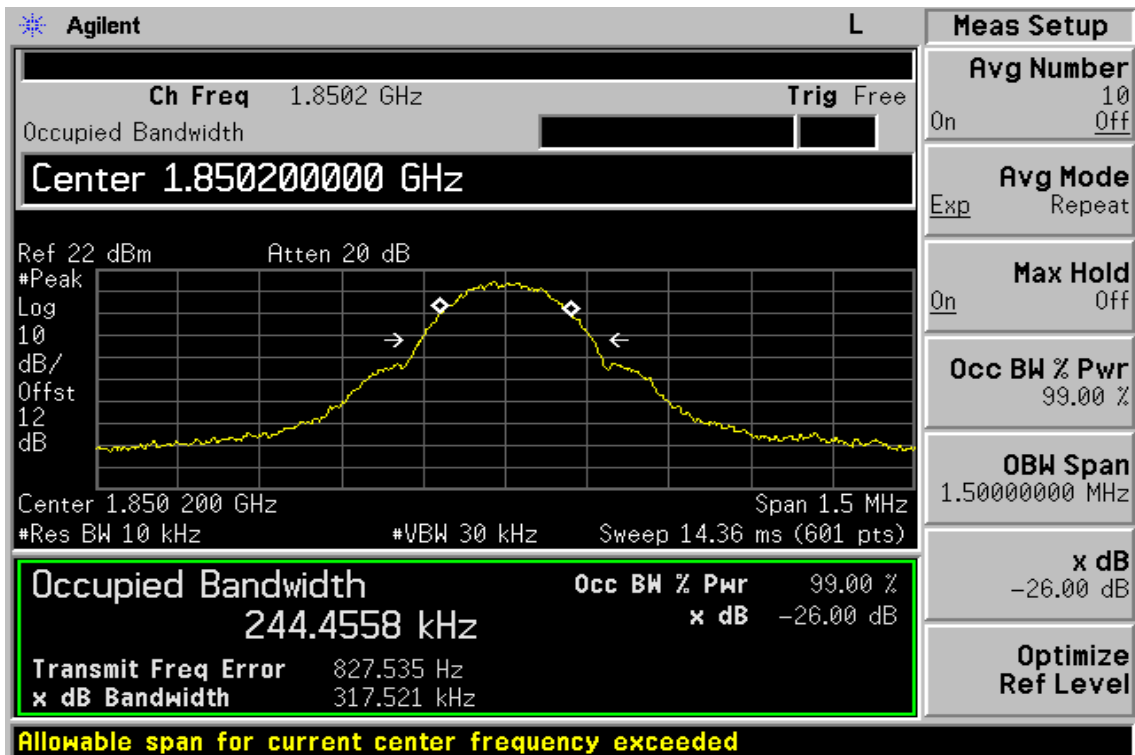

Figure 7-10: EDGE 1900 Channel Low



This document is issued by the Company subject to its General Conditions of Service printed overleaf or available on request and accessible at www.sgs.com. Attention is drawn to the limitations of liability, indemnification, and Jurisdictional issued defined therein. Unless otherwise stated, the results shown in this test report refer only to the sample(s) tested. This document cannot be reproduced except in full, without prior approval of Company. Any unauthorized alteration, forgery or falsification of the content or appearance of this report is unlawful and offenders may be prosecuted to the fullest extent of the law. 此報告是遵循本公司訂定之通用服務條款所製作發放，請注意此條款列印於背面，亦可在www.sgs.com中查閱。將本公司之義務，免責，管轄權皆明確規範之。除非另有說明，此報告結果僅對檢驗之樣品負責。本報告未經本公司書面許可，不可部份複製。對本報告內容或外觀之任何未經授權之變更、偽造、竄改皆屬非法，違犯者將會被依法追訴。

Figure 7-11: EDGE 1900 Channel Mid

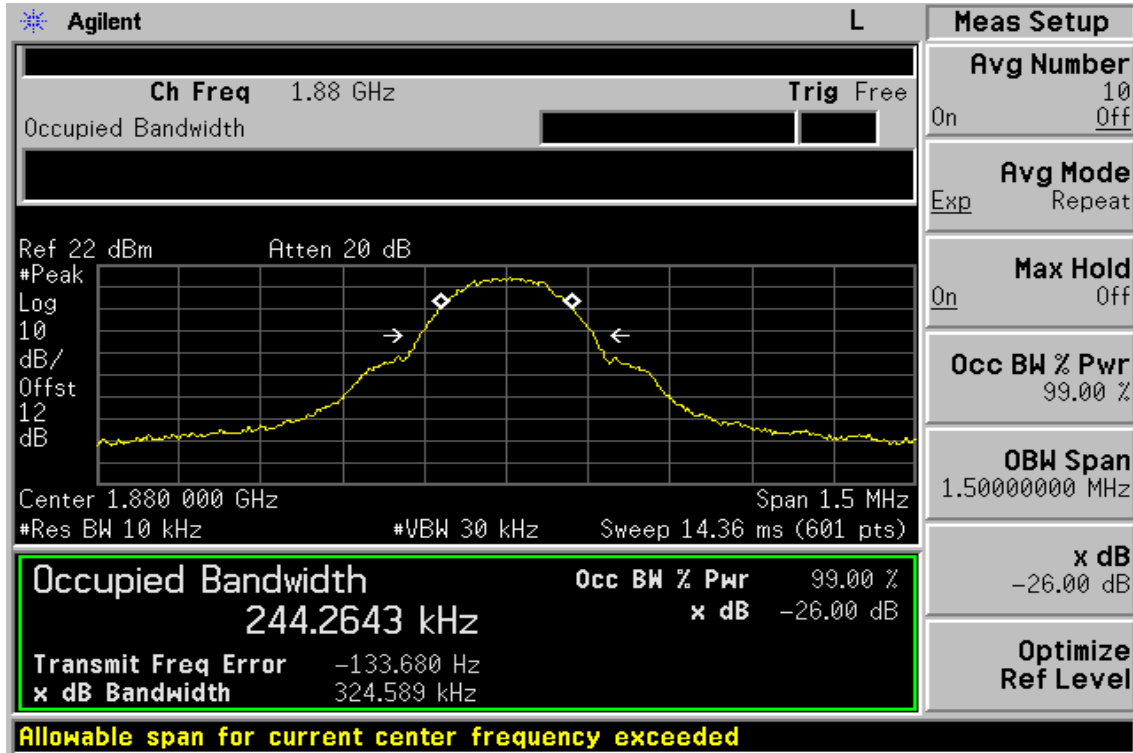
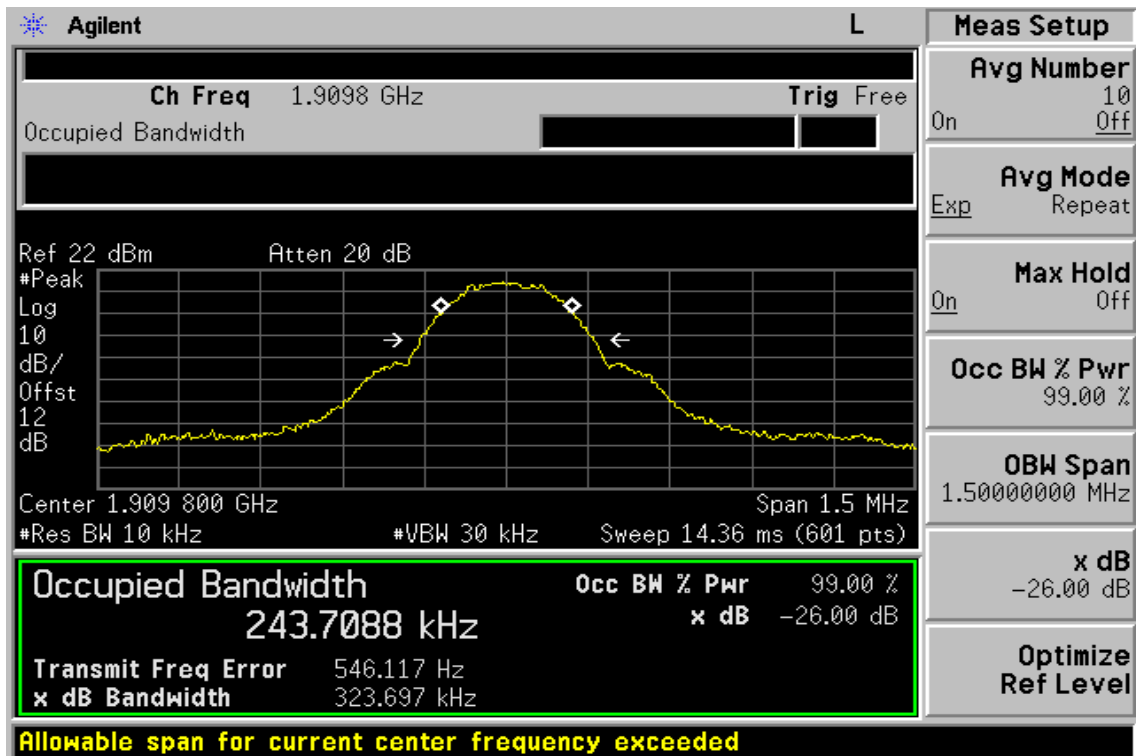

Figure 7-12: EDGE 1900 Channel High



This document is issued by the Company subject to its General Conditions of Service printed overleaf or available on request and accessible at www.sgs.com. Attention is drawn to the limitations of liability, indemnification, and Jurisdictional issued defined therein. Unless otherwise stated, the results shown in this test report refer only to the sample(s) tested. This document cannot be reproduced except in full, without prior approval of Company. Any unauthorized alteration, forgery or falsification of the content or appearance of this report is unlawful and offenders may be prosecuted to the fullest extent of the law. 此報告是遵循本公司訂定之通用服務條款所製作發放，請注意此條款列印於背面，亦可在www.sgs.com中查閱。將本公司之義務，免責，管轄權皆明確規範之。除非另有說明，此報告結果僅對檢驗之樣品負責。本報告未經本公司書面許可，不可部份複製。對本報告內容或外觀之任何未經授權之變更、偽造、竄改皆屬非法，違犯者將會被依法追訴。

8. OUT OF BAND EMISSION AT ANTENNA TERMINALS

8.1 Standard Applicable

According to FCC §2.1051.

FCC §22.917(a), §24.238(a), the magnitude of each spurious and harmonic emission that can be detected when the equipment is operated under the conditions specified in the instruction manual and/ or alignment procedure, shall not be less than $43 + 10 \log$ (mean output power in watts) dBc below the mean power output outside a license's frequency block (-13dBm)

8.2 Test SET-UP

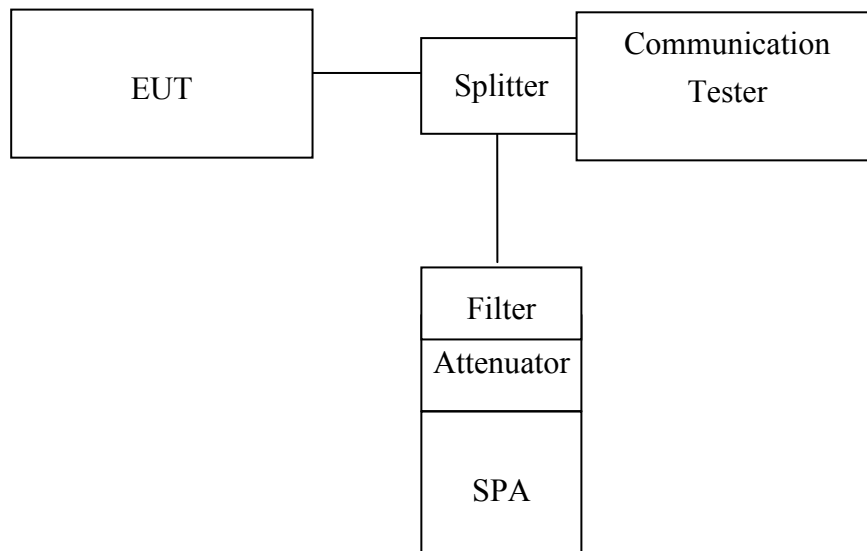

Note: Measurement setup for testing on Antenna connector

8.3 Measurement Procedure

The RF output of the transceiver was connected to a spectrum analyzer through appropriate attenuation. The resolution bandwidth of the spectrum analyzer was set at 1MHz, sufficient scans were taken to show the out of band Emissions if any up to 10th harmonic.

For the out of band: Set the RBW, VBW = 1MHz, Start=30MHz, Stop= 10 th harmonic.
Limit = -13dBm

Band Edge Requirements: In the 1 MHz bands immediately outside and adjacent to the frequency block, a resolution bandwidth of at least 1 percent of the emission bandwidth of the fundamental emission of the transmitter may be employed to measure the out of band Emissions. Limit, -13dBm.

8.4 Measurement Equipment Used:

Conducted Emission Test Site					
EQUIPMENT TYPE	MFR	MODEL NUMBER	SERIAL NUMBER	LAST CAL.	CAL DUE.
Spectrum Analyzer	Agilent	E4446A	MY43360126	04/27/2007	04/27/2008
Spectrum Analyzer	Agilent	E7405A	US41160416	07/04/2007	07/03/2008
Spectrum Analyzer	R&S	FSP 40	100034	01/05/2008	01/04/2009
Communication Test	R&S	SMU200	N/A	N/A	N/A
Power Sensor	Anritsu	MA2490A	31431	07/07/2007	07/06/2008
Power Meter	Anritsu	ML2487A	6K00002070	07/07/2007	07/06/2008
Temperature Chamber	TERCHY	MHG-120LF	911009	04/26/2007	04/25/2008
Low Loss Cable	HUBER+SUHNER	SUCOFLEX 104PEA	N/A	N/A	N/A
Attenuator	Mini-Circuit	BW-S10W5	N/A	07/05/2007	07/04/2008
Attenuator	Mini-Circuit	BW-S6W5	N/A	07/05/2007	07/04/2008
Splitter	Agilent	11636B	51728	07/05/2007	07/04/2008
DC Power Supply	Agilent	6038A	2929A-07548	06/27/2007	06/26/2008

This document is issued by the Company subject to its General Conditions of Service printed overleaf or available on request and accessible at www.sgs.com. Attention is drawn to the limitations of liability, indemnification, and Jurisdictional issued defined therein. Unless otherwise stated, the results shown in this test report refer only to the sample(s) tested. This document cannot be reproduced except in full, without prior approval of Company. Any unauthorized alteration, forgery or falsification of the content or appearance of this report is unlawful and offenders may be prosecuted to the fullest extent of the law. 此報告是遵循本公司訂定之通用服務條款所製作發放，請注意此條款列印於背面，亦可在www.sgs.com中查閱。將本公司之義務，免責，管轄權皆明確規範之。除非另有說明，此報告結果僅對檢驗之樣品負責。本報告未經本公司書面許可，不可部份複製。對本報告內容或外觀之任何未經授權之變更、偽造、竄改皆屬非法，違犯者將會被依法追訴。

8.5 Measurement Result

Figure 8-1: Out of Band emission at antenna terminals– GSM Channel Lowest

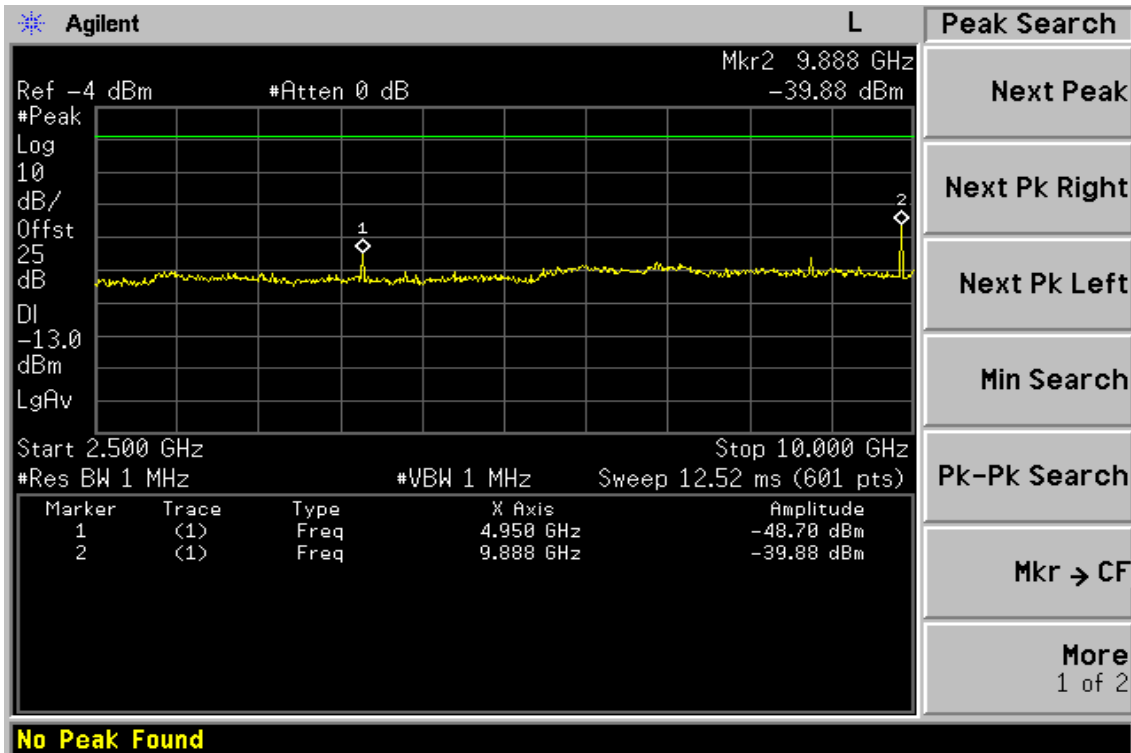
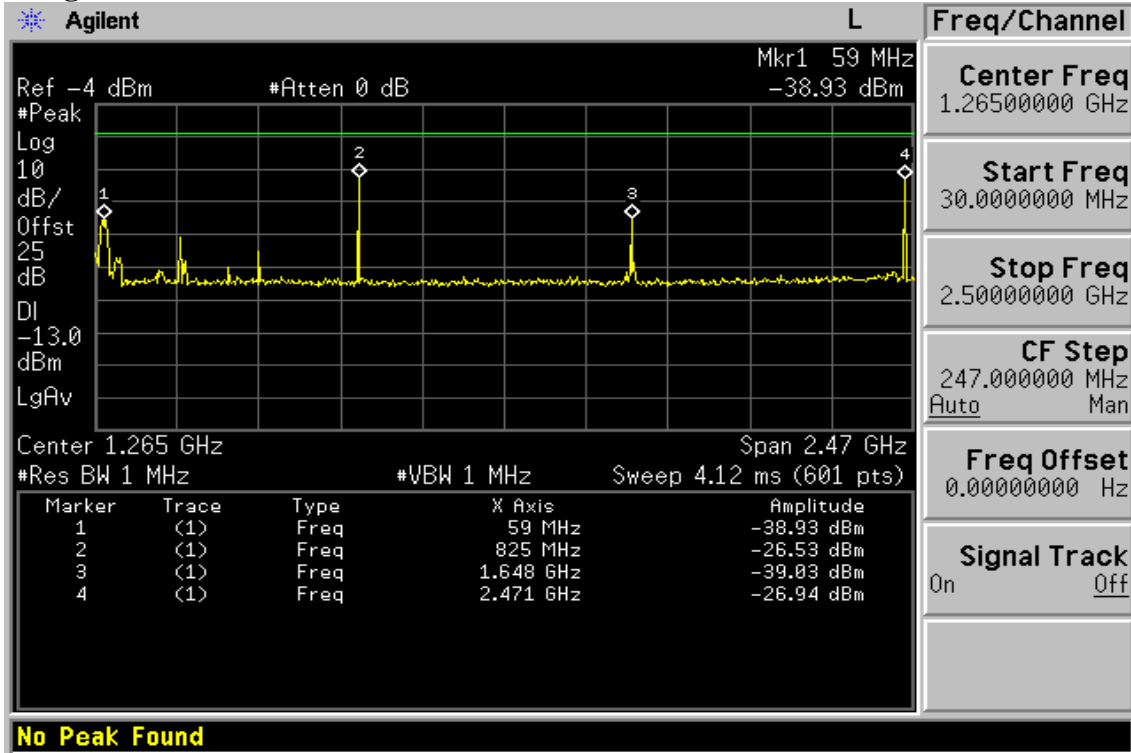

This document is issued by the Company subject to its General Conditions of Service printed overleaf or available on request and accessible at www.sgs.com. Attention is drawn to the limitations of liability, indemnification, and Jurisdictional issued defined therein. Unless otherwise stated, the results shown in this test report refer only to the sample(s) tested. This document cannot be reproduced except in full, without prior approval of Company. Any unauthorized alteration, forgery or falsification of the content or appearance of this report is unlawful and offenders may be prosecuted to the fullest extent of the law. 此報告是遵循本公司訂定之通用服務條款所製作發放，請注意此條款列印於背面，亦可在www.sgs.com中查閱。將本公司之義務，免責，管轄權皆明確規範之。除非另有說明，此報告結果僅對檢驗之樣品負責。本報告未經本公司書面許可，不可部份複製。對本報告內容或外觀之任何未經授權之變更、偽造、竄改皆屬非法，違犯者將會被依法追訴。

Figure 8-2: Out of Band emission at antenna terminals –GSM Channel Mid

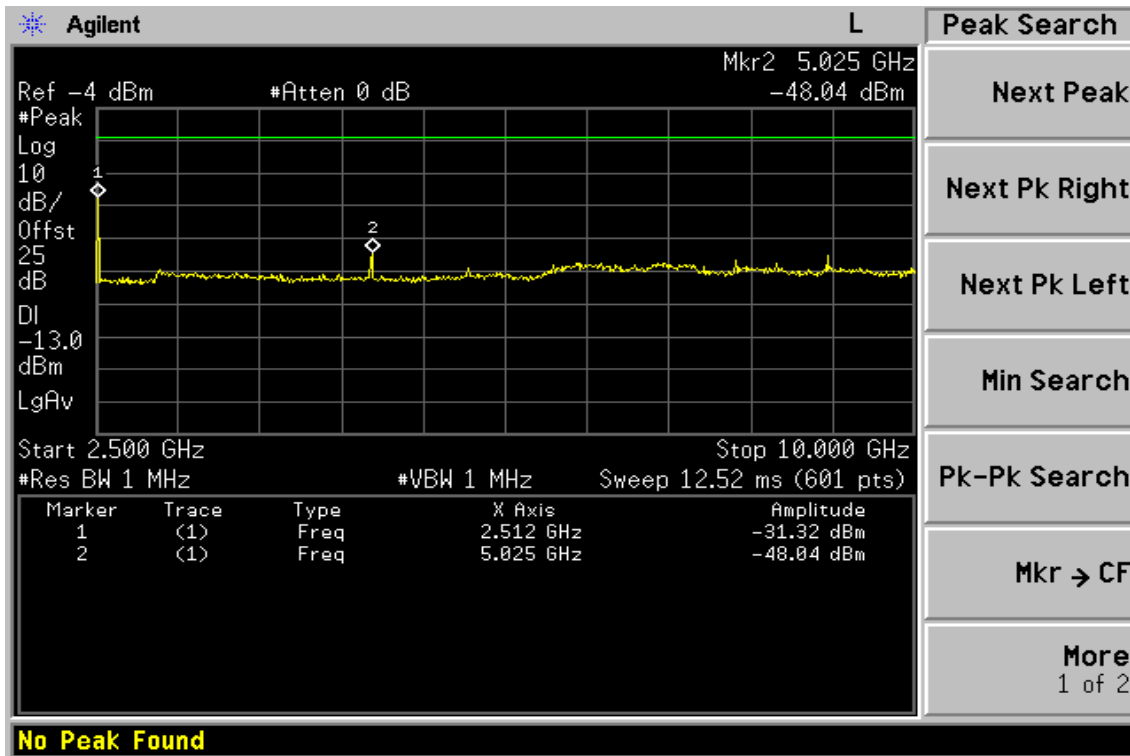
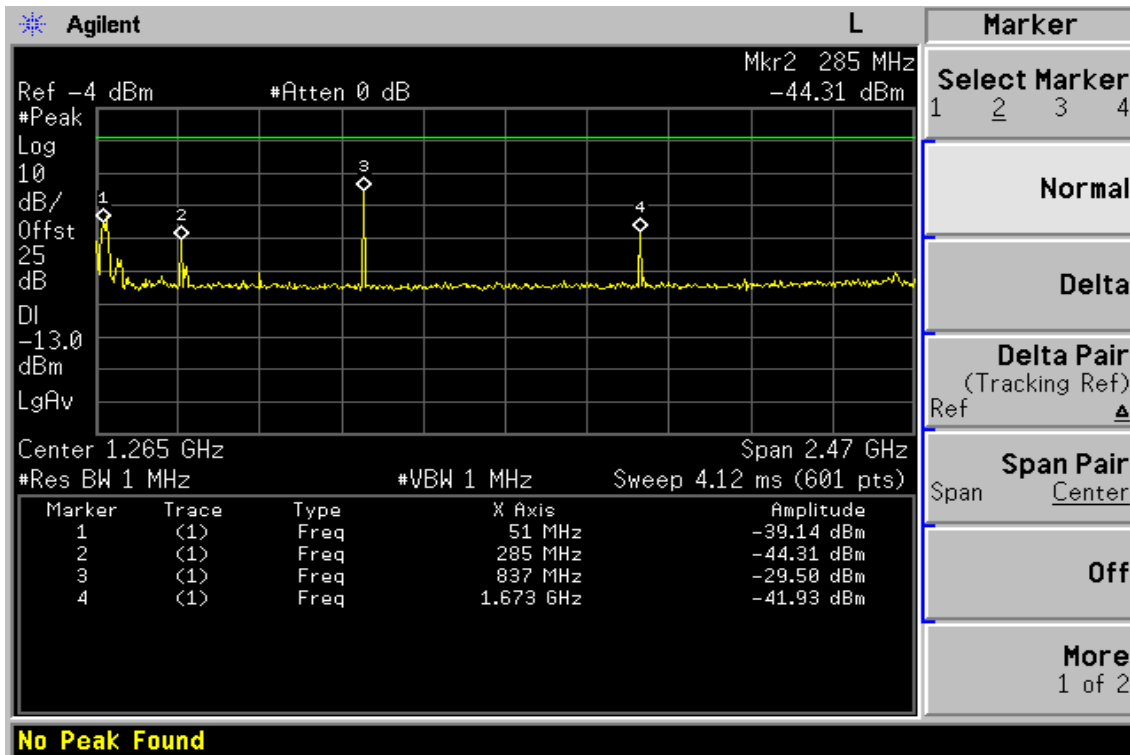

This document is issued by the Company subject to its General Conditions of Service printed overleaf or available on request and accessible at www.sgs.com. Attention is drawn to the limitations of liability, indemnification, and Jurisdictional issued defined therein. Unless otherwise stated, the results shown in this test report refer only to the sample(s) tested. This document cannot be reproduced except in full, without prior approval of Company. Any unauthorized alteration, forgery or falsification of the content or appearance of this report is unlawful and offenders may be prosecuted to the fullest extent of the law. 此報告是遵循本公司訂定之通用服務條款所製作發放，請注意此條款列印於背面，亦可在www.sgs.com中查閱。將本公司之義務，免責，管轄權皆明確規範之。除非另有說明，此報告結果僅對檢驗之樣品負責。本報告未經本公司書面許可，不可部份複製。對本報告內容或外觀之任何未經授權之變更、偽造、竄改皆屬非法，違犯者將會被依法追訴。

Figure 8-3: Out of Band emission at antenna terminals–GSM Channel Highest

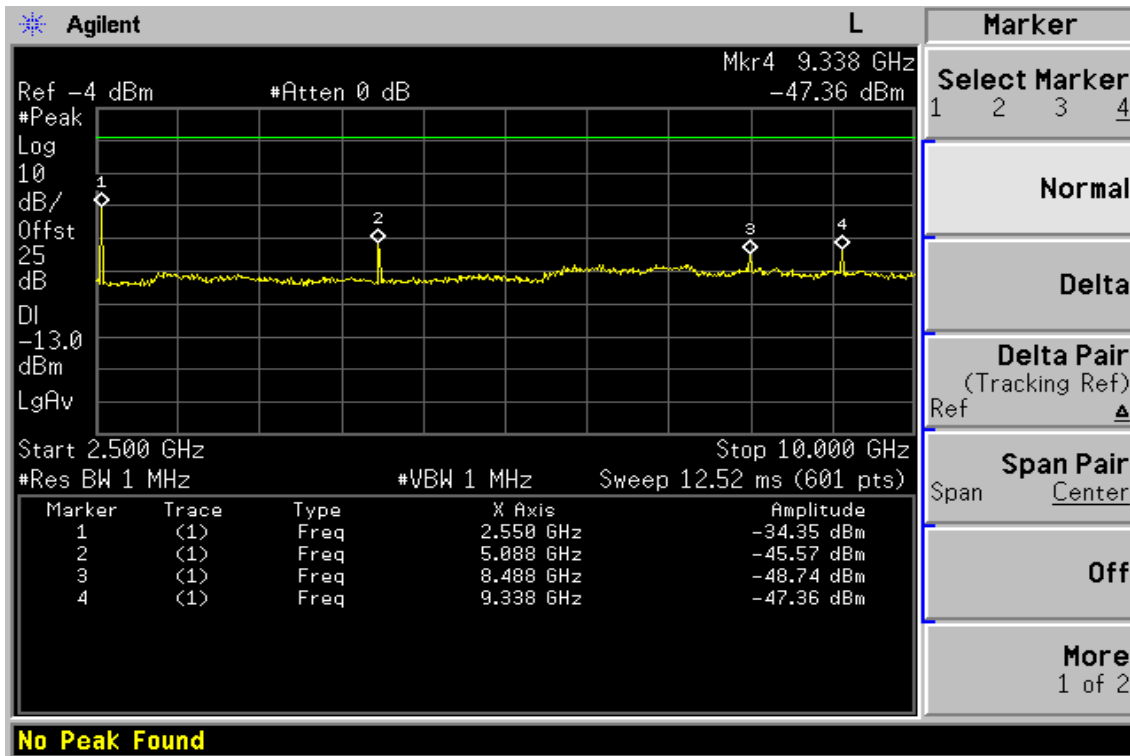
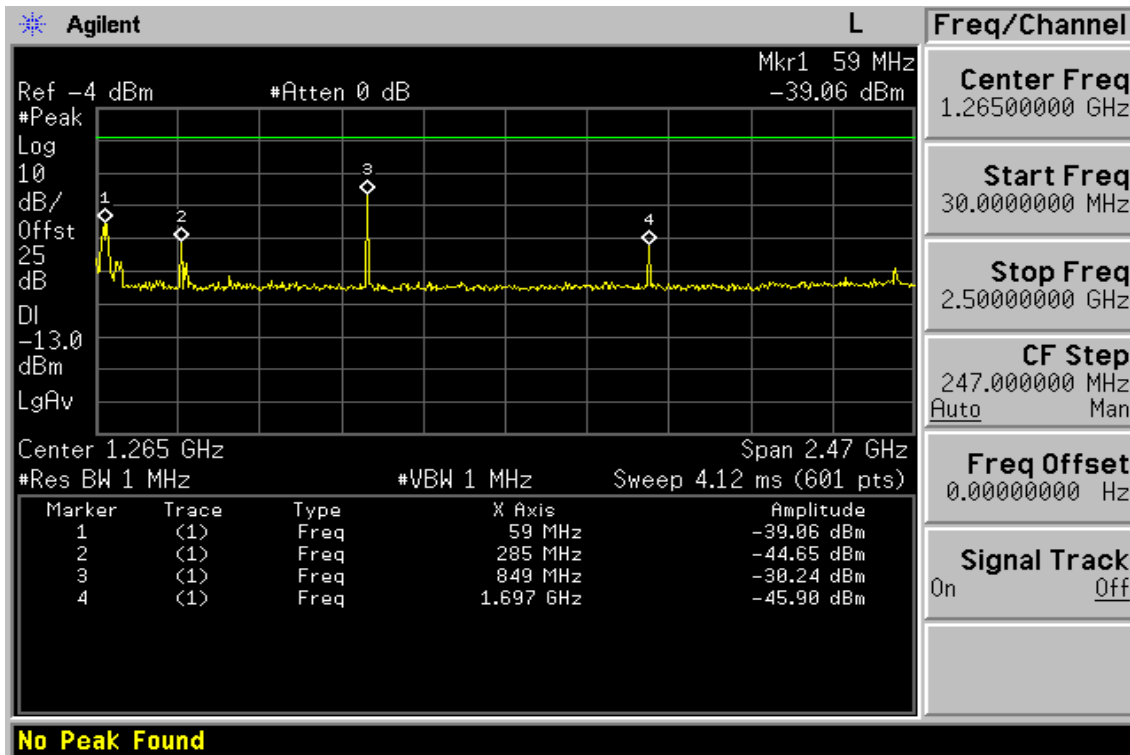

This document is issued by the Company subject to its General Conditions of Service printed overleaf or available on request and accessible at www.sgs.com. Attention is drawn to the limitations of liability, indemnification, and Jurisdictional issued defined therein. Unless otherwise stated, the results shown in this test report refer only to the sample(s) tested. This document cannot be reproduced except in full, without prior approval of Company. Any unauthorized alteration, forgery or falsification of the content or appearance of this report is unlawful and offenders may be prosecuted to the fullest extent of the law. 此報告是遵循本公司訂定之通用服務條款所製作發放，請注意此條款列印於背面，亦可在www.sgs.com中查閱。將本公司之義務，免責，管轄權皆明確規範之。除非另有說明，此報告結果僅對檢驗之樣品負責。本報告未經本公司書面許可，不可部份複製。對本報告內容或外觀之任何未經授權之變更、偽造、竄改皆屬非法，違犯者將會被依法追訴。

Figure 8-4: Band edge emission at antenna terminals – GSM Channel Lowest

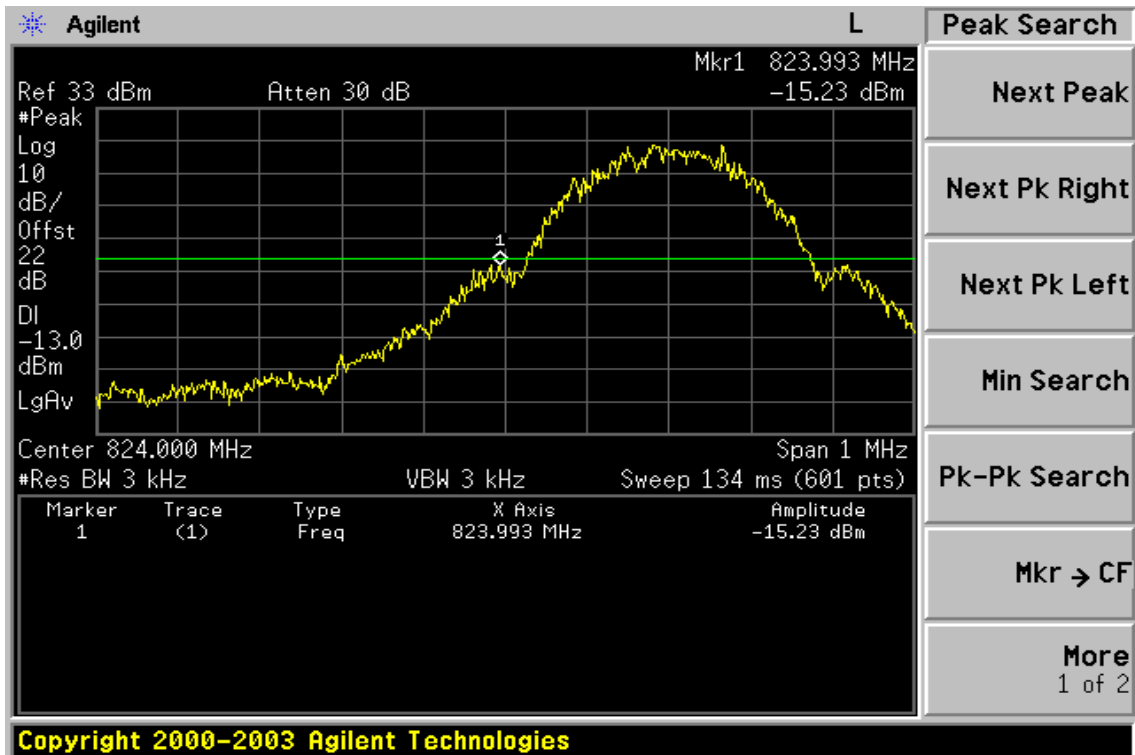
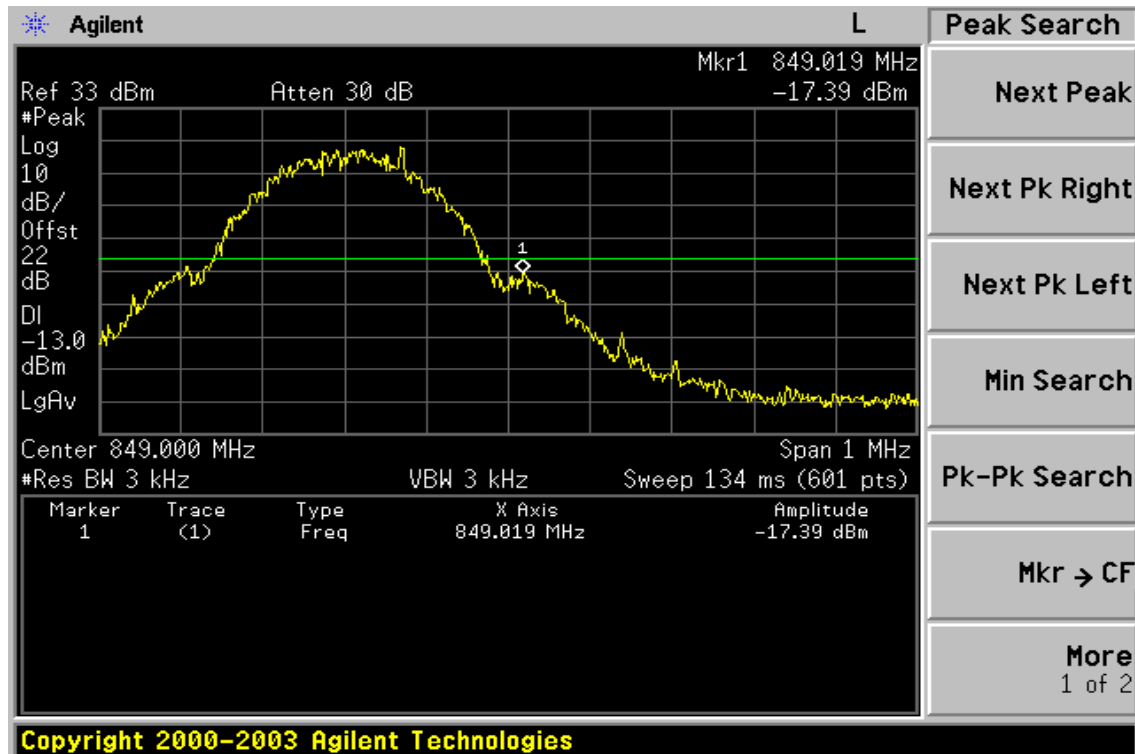
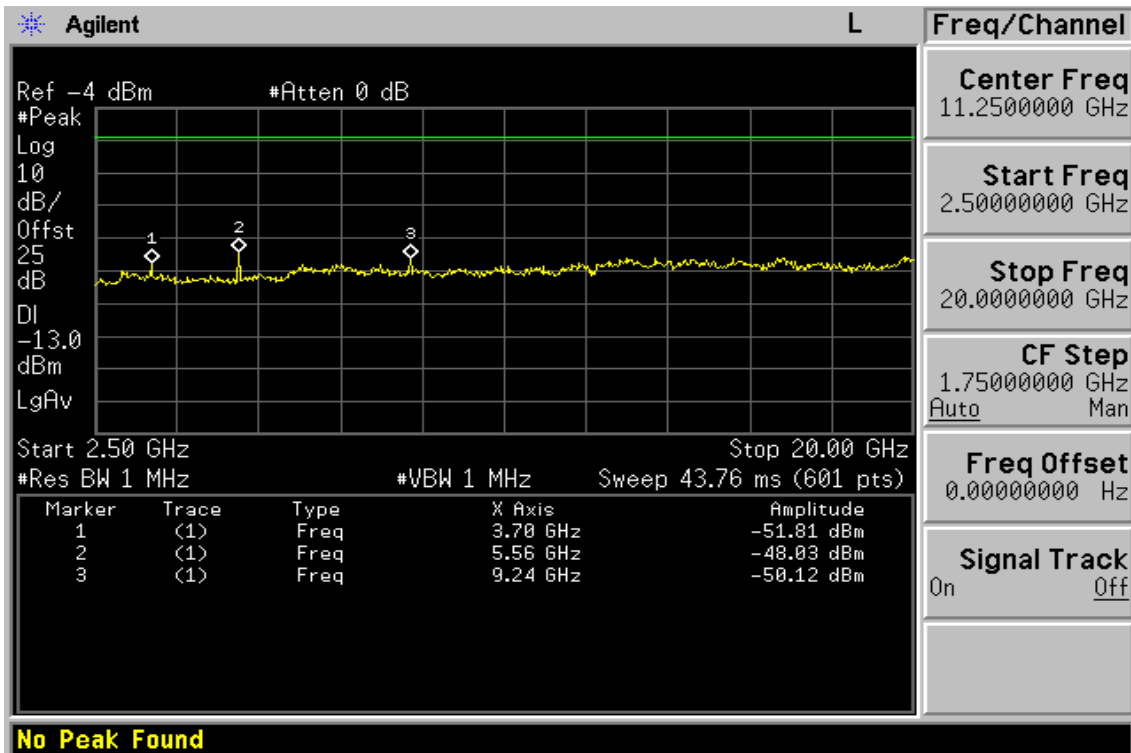
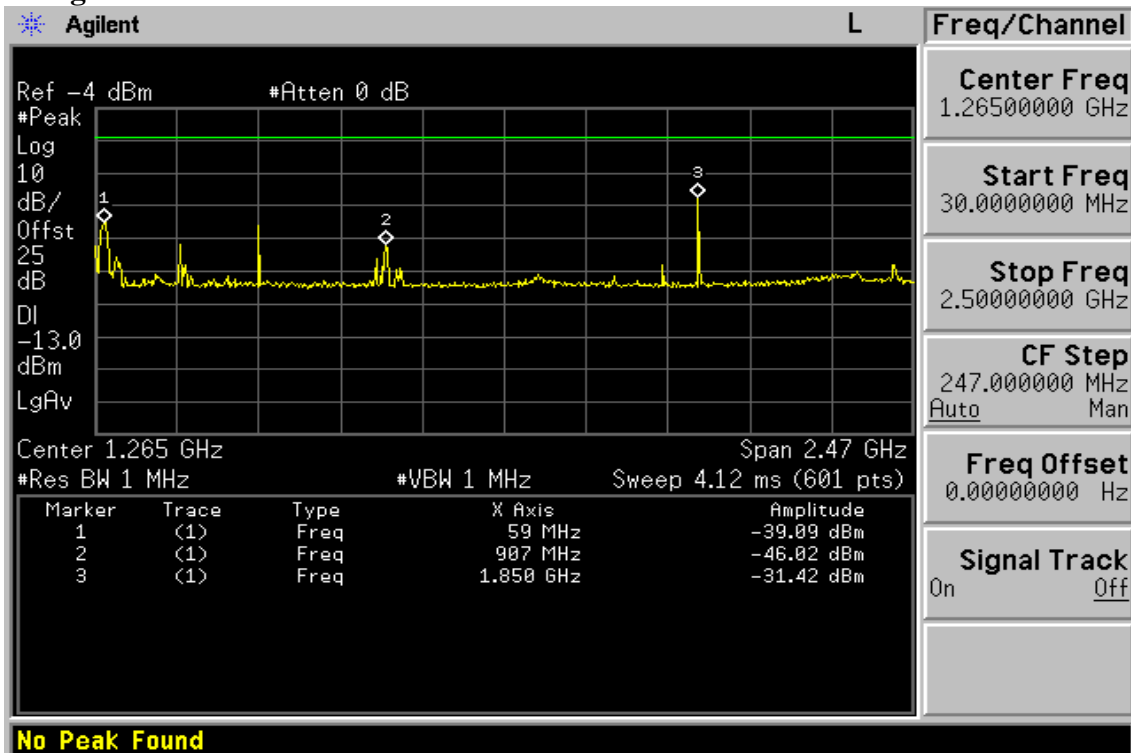

Figure 8-5: Band edge emission at antenna terminals – GSM Channel Highest



This document is issued by the Company subject to its General Conditions of Service printed overleaf or available on request and accessible at www.sgs.com. Attention is drawn to the limitations of liability, indemnification, and Jurisdictional issued defined therein. Unless otherwise stated, the results shown in this test report refer only to the sample(s) tested. This document cannot be reproduced except in full, without prior approval of Company. Any unauthorized alteration, forgery or falsification of the content or appearance of this report is unlawful and offenders may be prosecuted to the fullest extent of the law. 此報告是遵循本公司訂定之通用服務條款所製作發放，請注意此條款列印於背面，亦可在www.sgs.com中查閱。將本公司之義務，免責，管轄權皆明確規範之。除非另有說明，此報告結果僅對檢驗之樣品負責。本報告未經本公司書面許可，不可部份複製。對本報告內容或外觀之任何未經授權之變更、偽造、竄改皆屬非法，違犯者將會被依法追訴。

Figure 8-6: Out of Band emission at antenna terminals– PCS Channel Lowest



This document is issued by the Company subject to its General Conditions of Service printed overleaf or available on request and accessible at www.sgs.com. Attention is drawn to the limitations of liability, indemnification, and Jurisdictional issued defined therein. Unless otherwise stated, the results shown in this test report refer only to the sample(s) tested. This document cannot be reproduced except in full, without prior approval of Company. Any unauthorized alteration, forgery or falsification of the content or appearance of this report is unlawful and offenders may be prosecuted to the fullest extent of the law. 此報告是遵循本公司訂定之通用服務條款所製作發放，請注意此條款列印於背面，亦可在www.sgs.com中查閱。將本公司之義務，免責，管轄權皆明確規範之。除非另有說明，此報告結果僅對檢驗之樣品負責。本報告未經本公司書面許可，不可部份複製。對本報告內容或外觀之任何未經授權之變更、偽造、竄改皆屬非法，違犯者將會被依法追訴。

Figure 8-7: Out of Band emission at antenna terminals –PCS Channel Mid

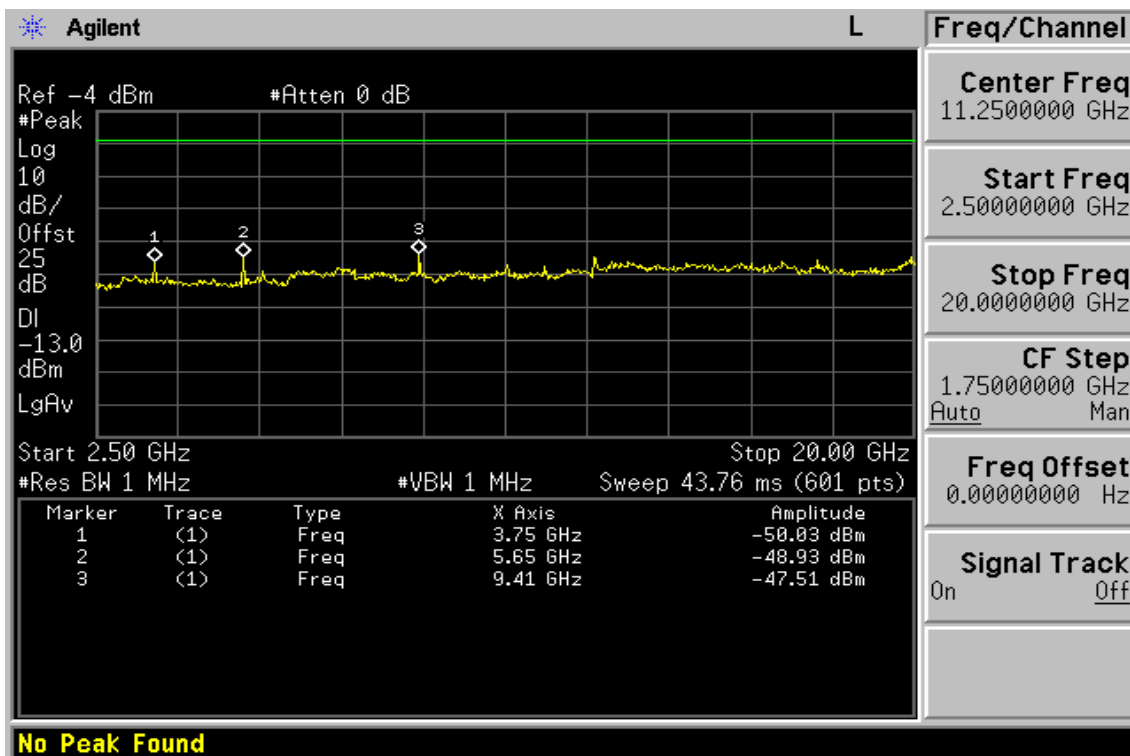
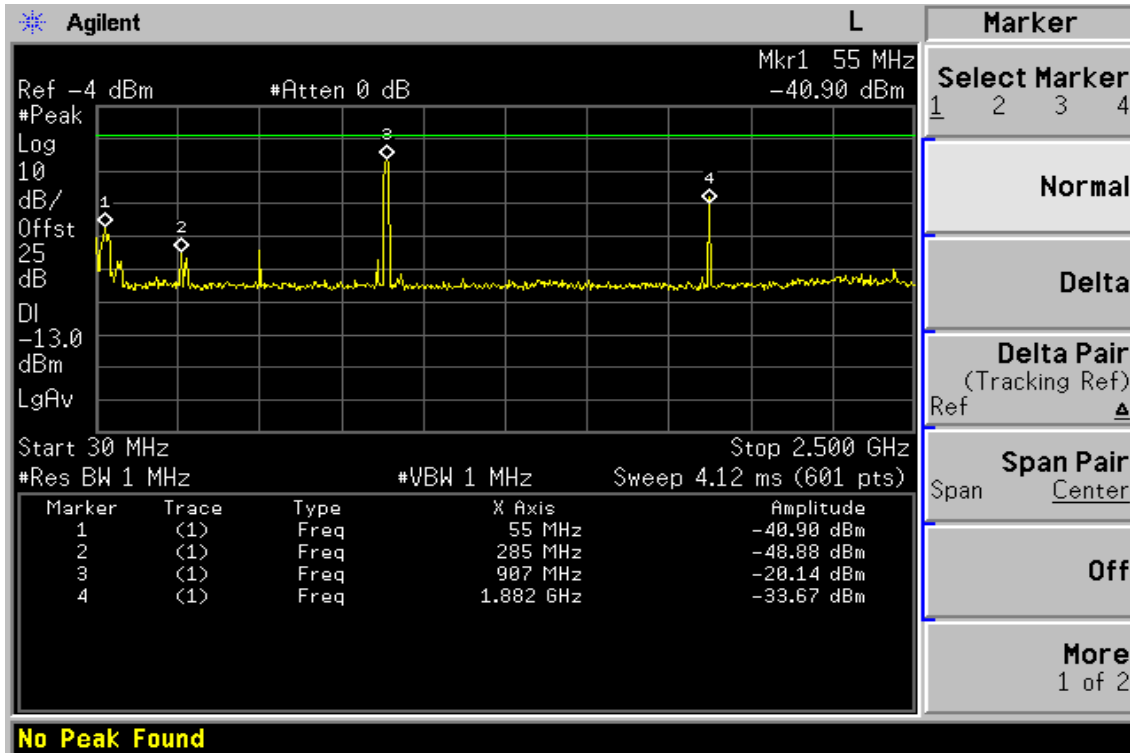

This document is issued by the Company subject to its General Conditions of Service printed overleaf or available on request and accessible at www.sgs.com. Attention is drawn to the limitations of liability, indemnification, and Jurisdictional issued defined therein. Unless otherwise stated, the results shown in this test report refer only to the sample(s) tested. This document cannot be reproduced except in full, without prior approval of Company. Any unauthorized alteration, forgery or falsification of the content or appearance of this report is unlawful and offenders may be prosecuted to the fullest extent of the law. 此報告是遵循本公司訂定之通用服務條款所製作發放，請注意此條款列印於背面，亦可在www.sgs.com中查閱。將本公司之義務，免責，管轄權皆明確規範之。除非另有說明，此報告結果僅對檢驗之樣品負責。本報告未經本公司書面許可，不可部份複製。對本報告內容或外觀之任何未經授權之變更、偽造、竄改皆屬非法，違犯者將會被依法追訴。

Figure 8-8: Out of Band emission at antenna terminals–PCS Channel Highest

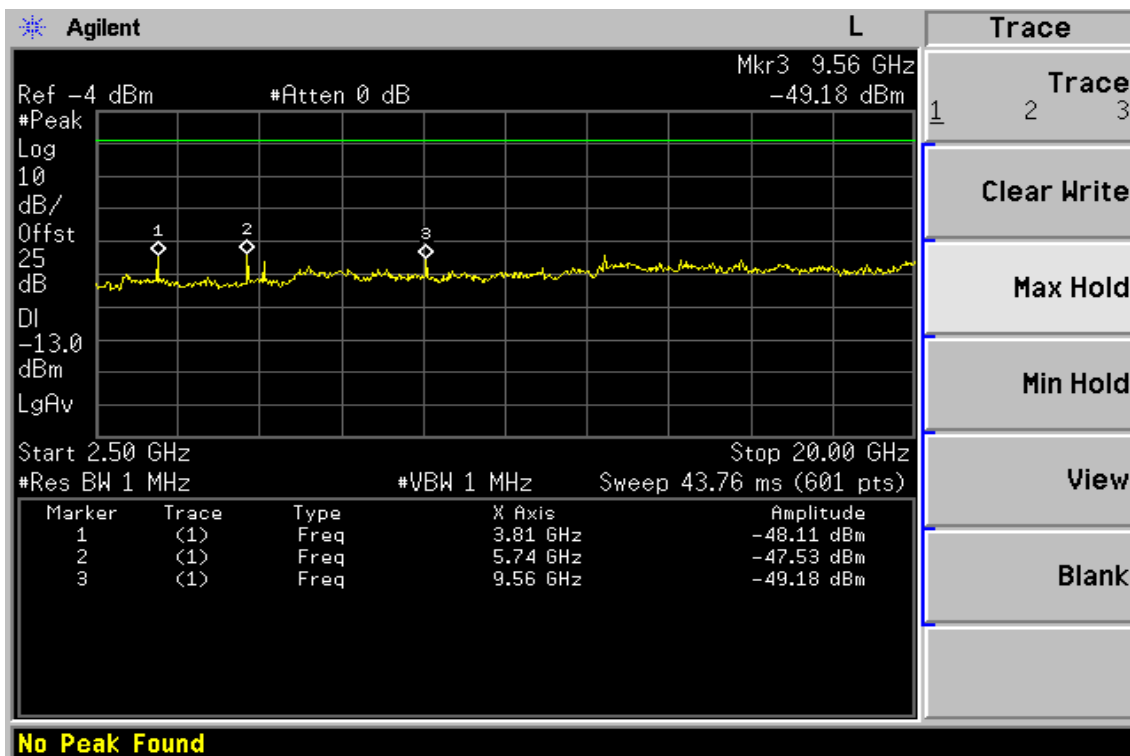
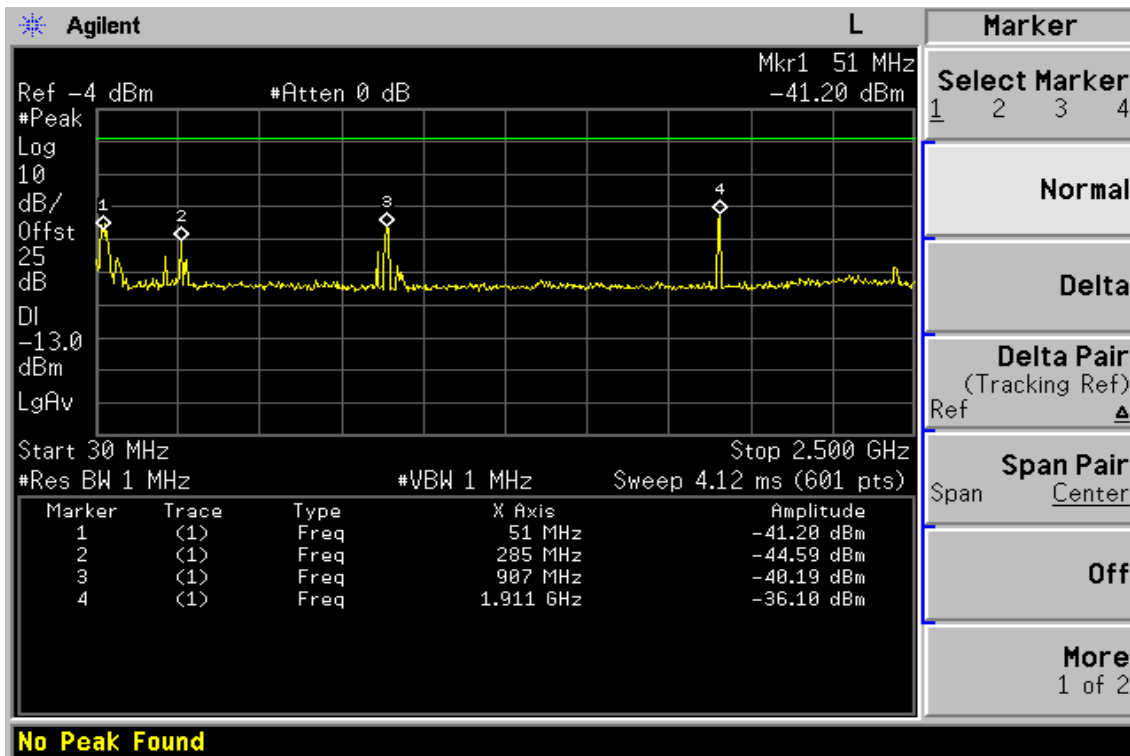

This document is issued by the Company subject to its General Conditions of Service printed overleaf or available on request and accessible at www.sgs.com. Attention is drawn to the limitations of liability, indemnification, and Jurisdictional issued defined therein. Unless otherwise stated, the results shown in this test report refer only to the sample(s) tested. This document cannot be reproduced except in full, without prior approval of Company. Any unauthorized alteration, forgery or falsification of the content or appearance of this report is unlawful and offenders may be prosecuted to the fullest extent of the law. 此報告是遵循本公司訂定之通用服務條款所製作發放，請注意此條款列印於背面，亦可在www.sgs.com中查閱。將本公司之義務，免責，管轄權皆明確規範之。除非另有說明，此報告結果僅對檢驗之樣品負責。本報告未經本公司書面許可，不可部份複製。對本報告內容或外觀之任何未經授權之變更、偽造、竄改皆屬非法，違犯者將會被依法追訴。

Figure 8-9: Bad edge emission at antenna terminals – PCS Channel Lowest

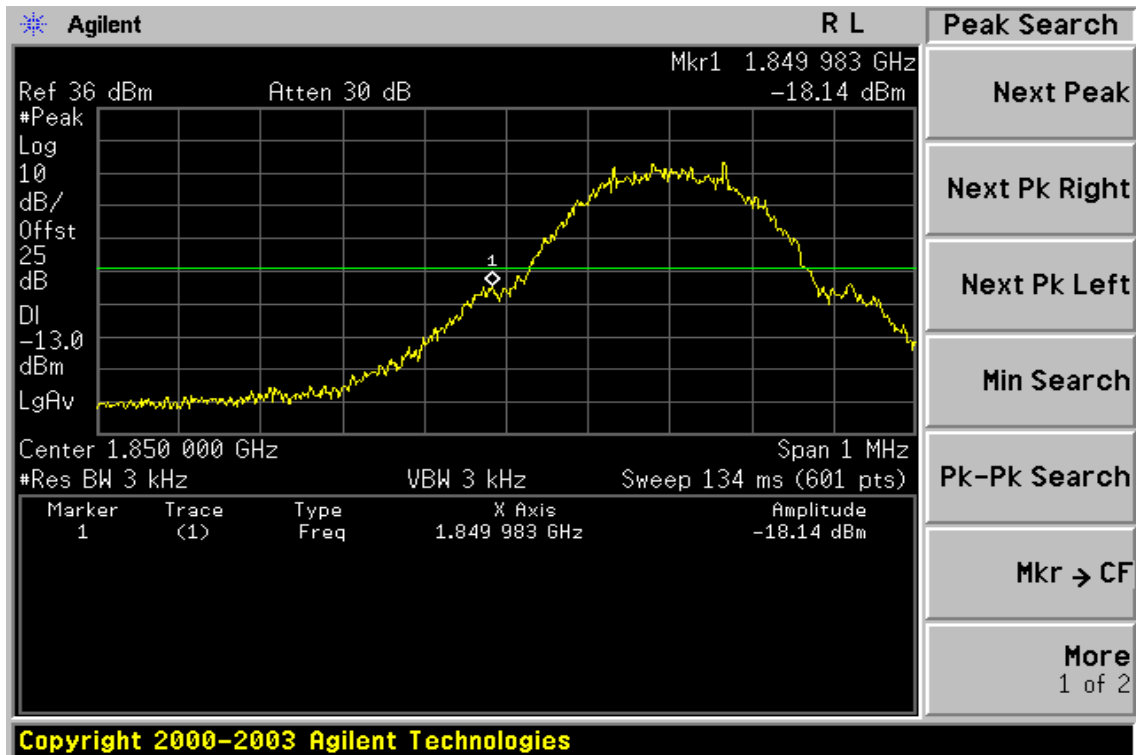
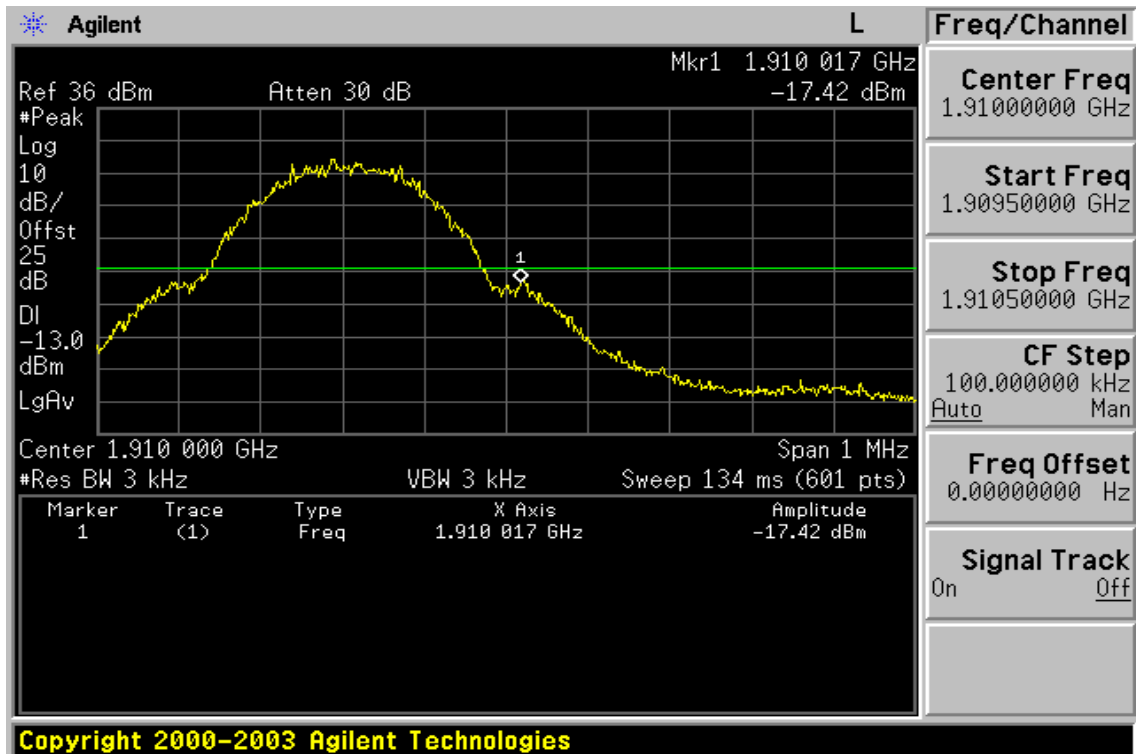

Figure 8-10: Band edge emission at antenna terminals – PCS Channel Highest



This document is issued by the Company subject to its General Conditions of Service printed overleaf or available on request and accessible at www.sgs.com. Attention is drawn to the limitations of liability, indemnification, and Jurisdictional issued defined therein. Unless otherwise stated, the results shown in this test report refer only to the sample(s) tested. This document cannot be reproduced except in full, without prior approval of Company. Any unauthorized alteration, forgery or falsification of the content or appearance of this report is unlawful and offenders may be prosecuted to the fullest extent of the law. 此報告是遵循本公司訂定之通用服務條款所製作發放，請注意此條款列印於背面，亦可在www.sgs.com中查閱。將本公司之義務，免責，管轄權皆明確規範之。除非另有說明，此報告結果僅對檢驗之樣品負責。本報告未經本公司書面許可，不可部份複製。對本報告內容或外觀之任何未經授權之變更、偽造、竄改皆屬非法，違犯者將會被依法追訴。

9. FIELD STRENGTH OF SPURIOUS RADIATION MEASUREMENT

9.1 Standard Applicable

According to FCC §2.1053,

FCC §22.917(a), §24.238(a), the magnitude of each spurious and harmonic emission that can be detected when the equipment is operated under the conditions specified in the instruction manual and/ or alignment procedure, shall not be less than $43 + 10 \log$ (mean output power in watts) dBc below the mean power output outside a license's frequency block (-13dBm)

9.2 EUT Setup (Block Diagram of Configuration)

(A) Radiated Emission Test Set-Up, Frequency Below 1000MHz

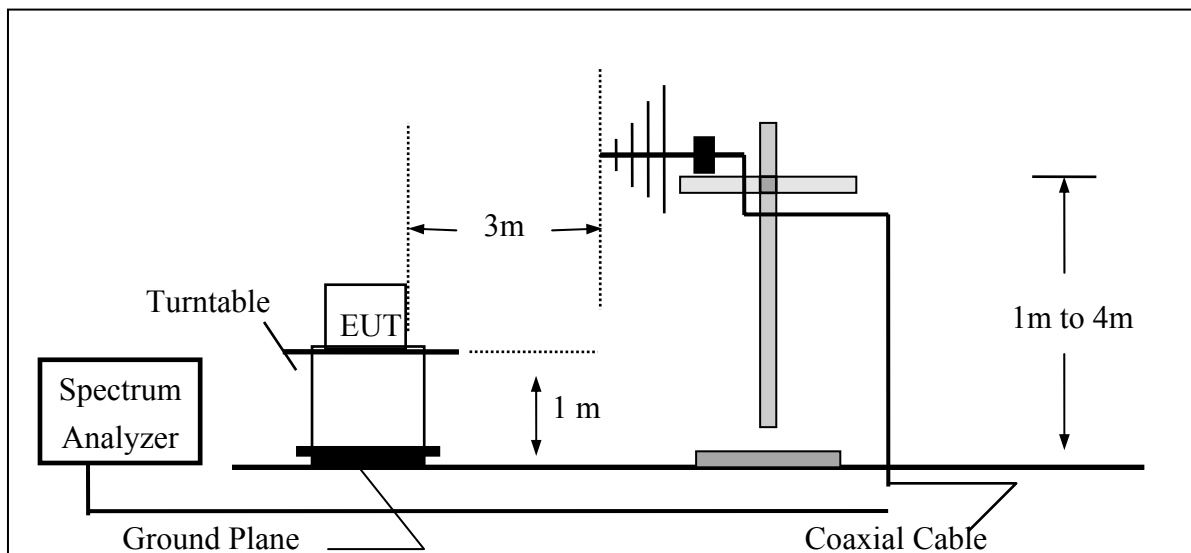

(B) Radiated Emission Test Set-UP Frequency Over 1 GHz

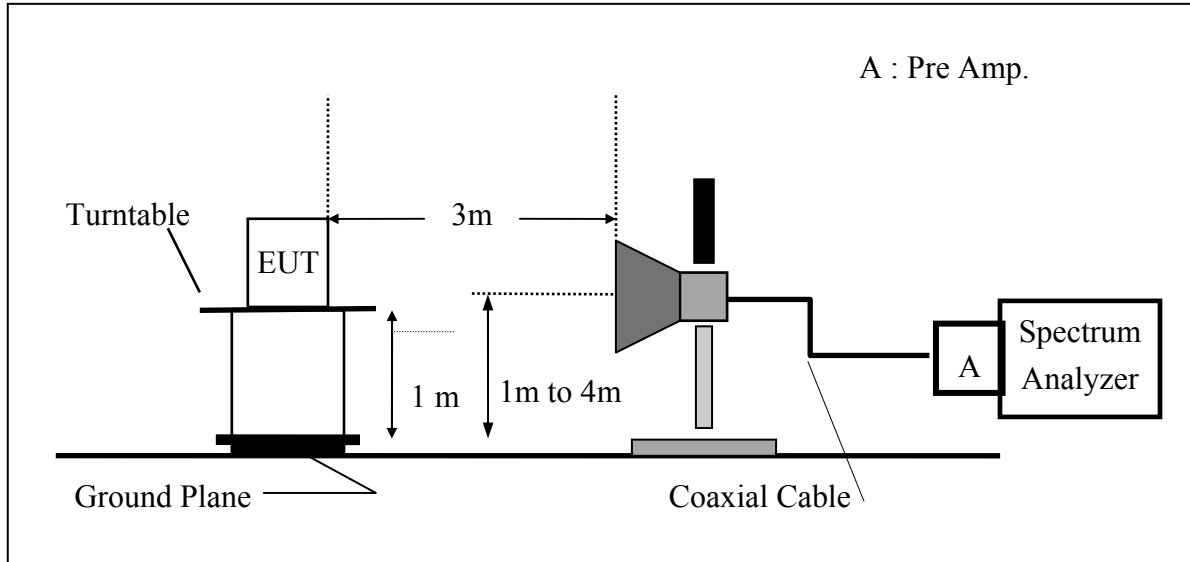

(C) Substituted Method Test Set-UP

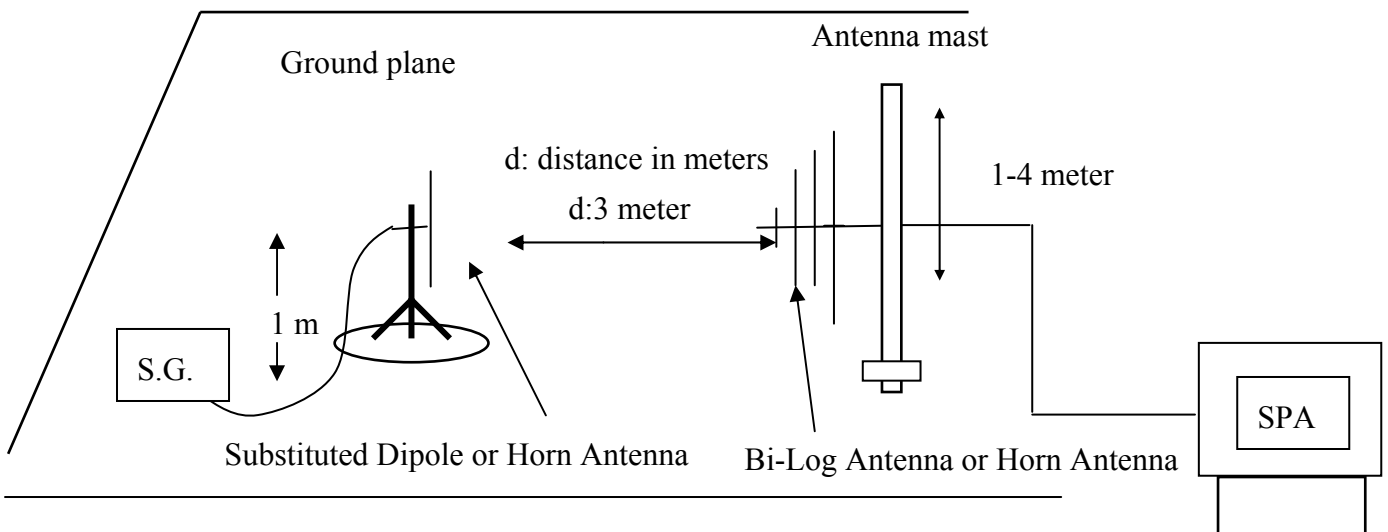

9.3 Measurement Procedure

The EUT was placed on a non-conductive, The measurement antenna was placed at a distance of 3 meters from the EUT. During the tests, the antenna height and the EUT azimuth were varied in order to identify the maximum level of emissions from the EUT. This maximization process was repeated with the EUT positioned in each of its three orthogonal orientations.

The frequency range up to tenth harmonic was investigated for each of three fundamental frequency (low, middle and high channels). Once spurious emission were identified, the power of the emission was determined using the substitution method.

The spurious emissions attenuation was calculated as the difference between radiated power at the fundamental frequency and the spurious emissions frequency.

$$\text{EIRP} = \text{S.G. output (dBm)} + \text{Antenna Gain(dBi)} - \text{Cable Loss (dB)}$$

9.4 Measurement Equipment Used:

EQUIPMENT TYPE	MFR	MODEL NUMBER	SERIAL NUMBER	LAST CAL.	CAL DUE.
Spectrum Analyzer	Agilent	E4446A	MY43360126	04/27/2007	04/26/2008
Spectrum Analyzer	Agilent	E7405A	US41160416	07/04/2007	07/03/2008
Communication Test	R&S	SMU200	N/A	N/A	N/A
Bi-log Antenna	SCHWAZBECK	VULB9160	3224	11/14/2008	11/13/2008
Horn antenna	SCHWAZBECK	BBHA 9120D	309/320	08/16/2007	08/15/2008
Pre-Amplifier	HP	8447D	2944A09469	07/19/2007	07/18/2008
Pre-Amplifier	HP	8494B	3008A00578	02/26/2007	02/25/2008
Signal Generator	R&S	SMR40	100210	02/09/2007	02/10/2008
Turn Table	HD	DT420	N/A	N.C.R	N.C.R
Antenna Tower	HD	MA240-N	240/657	N.C.R	N.C.R
Controller	HD	HD100	N/A	N.C.R	N.C.R
Low Loss Cable	HUBER+SUHNER	SUCOFLEX 104PEA-10M	10m	10/09/2007	10/08/2008
Low Loss Cable	HUBER+SUHNER	SUCOFLEX 104PEA-3M	3m	10/09/2007	10/08/2008
Low Loss Cable	HUBER+SUHNER	SUCOFLEX 104PEA-0.5M	0.5m	10/09/2007	10/08/2008
Site NSA	SGS	966 chamber	N/A	11/17/2007	11/16/2008
Attenuator	Mini-Circuit	BW-S10W5	N/A	09/23/2007	09/22/2008
Dipole Antenna	SCHWAZBECK	VHAP	908/909	06/09/2007	06/10/2008
Dipole Antenna	SCHWAZBECK	UHAP	891/892	06/09/2007	06/10/2008
Horn antenna	SCHWAZBECK	BBHA 9120D	N/A	08/16/2007	08/15/2008

9.5 Measurement Result

Refer to attach tabular data sheets.

Radiated Spurious Emission Measurement Result: GSM 850 Mode

Operation Mode	: TX CH Low E2 Mode	Test Date:	Feb. 13, 2008
Fundamental Frequency	: 824.20 MHz	Test By:	Bondi
Temperature	: 25	Pol:	Ver
Humidity	: 65%		

Freq. (MHz)	SPA Reading (dBuV)	Ant.Pol. H/V	S.G Out-put (dBm)	Antenna Gain (dB/dBi)	Cable Loss (dB)	ERP/EIRP (dBm)	Limit (dBm)	Safe Margin (dBm)
101.78	47.02	V	-56.46	-7.76	1.23	-65.45	-13.00	-52.45
286.08	38.26	V	-61.63	-7.91	1.99	-71.53	-13.00	-58.53
824.00	66.81	V	-20.52	-7.87	3.64	-32.04	-13.00	-19.04
1648.40	56.34	V	-50.70	9.29	5.06	-46.47	-13.00	-33.47
2472.60	59.12	V	-44.94	10.08	6.30	-41.17	-13.00	-28.17
3296.80	---	V		12.17	7.26		-13.00	
4121.00	---	V		12.61	8.33		-13.00	
4945.20	---	V		12.65	9.19		-13.00	
5769.40	---	V		13.55	9.80		-13.00	
6593.60	---	V		12.05	10.61		-13.00	
7417.80	---	V		11.49	11.28		-13.00	
8242.00	---	V		11.48	12.26		-13.00	

Measurement uncertainty	30MHz - 80MHz: 5.04dB
	80MHz -1000MHz: 3.76dB
	1GHz - 13GHz: 4.45dB

Remark :

- 1 The emission behaviors belong to narrowband spurious emission.
- 2 Remark"---" means that the emission level is too low to be measured
- 3 The result basic equation calculation is as follows:
- 4 $ERP/EIRP (dBm) = SG \text{ Setting}(dBm) + Antenna \text{ Gain} (dB/dBi) - Cable \text{ loss} (dB)$

Radiated Spurious Emission Measurement Result: GSM 850 Mode

Operation Mode	: TX CH Low E2 Mode	Test Date:	Feb. 13, 2008
Fundamental Frequency	: 824.20 MHz	Test By:	Bondi
Temperature	: 25	Pol:	Hor
Humidity	: 65%		

Freq. (MHz)	SPA Reading (dBuV)	Ant.Pol. H/V	S.G Out-put (dBm)	Antenna Gain (dB/dBi)	Cable Loss (dB)	ERP/EIRP (dBm)	Limit (dBm)	Safe Margin (dBm)
36.79	46.67	H	-57.13	-4.16	0.75	-62.03	-13.00	-49.03
101.78	43.11	H	-59.93	-7.76	1.23	-68.91	-13.00	-55.91
824.00	81.70	H	-5.96	-7.87	3.64	-17.48	-13.00	-4.48
1648.40	54.71	H	-52.30	9.29	5.06	-48.07	-13.00	-35.07
2472.60	47.03	H	-57.03	10.08	6.30	-53.25	-13.00	-40.25
3296.80	---	H		12.17	7.26		-13.00	
4121.00	---	H		12.61	8.33		-13.00	
4945.20	---	H		12.65	9.19		-13.00	
5769.40	---	H		13.55	9.80		-13.00	
6593.60	---	H		12.05	10.61		-13.00	
7417.80	---	H		11.49	11.28		-13.00	
8242.00	---	H		11.48	12.26		-13.00	

Measurement uncertainty	30MHz - 80MHz: 5.04dB
	80MHz -1000MHz: 3.76dB
	1GHz - 13GHz: 4.45dB

Remark :

- 1 The emission behaviors belong to narrowband spurious emission.
- 2 Remark"---" means that the emission level is too low to be measured
- 3 The result basic equation calculation is as follows:
- 4 $ERP/EIRP (dBm) = SG \text{ Setting}(dBm) + Antenna \text{ Gain} (dB/dBi) - Cable \text{ loss} (dB)$

Radiated Spurious Emission Measurement Result: GSM 850 Mode

Operation Mode	: TX CH Mid E2 Mode	Test Date:	Feb. 13, 2008
Fundamental Frequency	: 836.60 MHz	Test By:	Bondi
Temperature	: 25	Pol:	Ver
Humidity	: 65%		

Freq. (MHz)	SPA. Reading (dBuV)	Ant.Pol. H/V	S.G Out-put (dBm)	Antenna Gain (dB/dBi)	Cable Loss (dB)	ERP/EIRP (dBm)	Limit (dBm)	Safe Margin (dBm)
43.58	44.51	V	-59.15	-1.92	0.83	-61.89	-13.00	-48.89
101.78	47.48	V	-56.00	-7.76	1.23	-64.99	-13.00	-51.99
1673.20	62.37	V	-44.66	9.36	5.10	-40.40	-13.00	-27.40
2509.80	58.87	V	-45.01	10.09	6.35	-41.27	-13.00	-28.27
3346.40	---	V		12.28	7.29		-13.00	
4183.00	---	V		12.62	8.40		-13.00	
5019.60	---	V		12.67	9.26		-13.00	
5856.20	---	V		13.68	9.85		-13.00	
6692.80	---	V		11.95	10.74		-13.00	
7529.40	---	V		11.45	11.35		-13.00	
8366.00	---	V		11.59	12.43		-13.00	

Measurement uncertainty	30MHz - 80MHz: 5.04dB
	80MHz - 1000MHz: 3.76dB
	1GHz - 13GHz: 4.45dB

Remark :

- 1 The emission behaviors belongs to narrowband spurious emission.
- 2 Remark"---" means that the emission level is too low to be measured
- 3 The result basic equation calculation is as follows:
- 4 $ERP/EIRP (dBm) = SG \text{ Setting}(dBm) + Antenna \text{ Gain} (dB/dBi) - Cable \text{ loss} (dB)$

Radiated Spurious Emission Measurement Result: GSM 850 Mode

Operation Mode	: TX CH Mid E2 Mode	Test Date:	Feb. 13, 2008
Fundamental Frequency	: 836.60 MHz	Test By:	Bondi
Temperature	: 25	Pol:	Hor
Humidity	: 65%		

Freq. (MHz)	SPA. Reading (dBuV)	Ant.Pol. H/V	S.G Out-put (dBm)	Antenna Gain (dB/dBi)	Cable Loss (dB)	ERP/EIRP (dBm)	Limit (dBm)	Safe Margin (dBm)
36.79	46.72	H	-57.08	-4.16	0.75	-61.98	-13.00	-48.98
101.78	43.60	H	-59.44	-7.76	1.23	-68.42	-13.00	-55.42
1673.20	59.46	H	-47.54	9.36	5.10	-43.27	-13.00	-30.27
2509.80	49.38	H	-54.49	10.09	6.35	-50.75	-13.00	-37.75
3346.40	---	H		12.28	7.29		-13.00	
4183.00	---	H		12.62	8.40		-13.00	
5019.60	---	H		12.67	9.26		-13.00	
5856.20	---	H		13.68	9.85		-13.00	
6692.80	---	H		11.95	10.74		-13.00	
7529.40	---	H		11.45	11.35		-13.00	
8366.00	---	H		11.59	12.43		-13.00	

Measurement uncertainty	30MHz - 80MHz: 5.04dB
	80MHz - 1000MHz: 3.76dB
	1GHz - 13GHz: 4.45dB

Remark :

- 1 The emission behaviors belong to narrowband spurious emission.
- 2 Remark"---" means that the emission level is too low to be measured
- 3 The result basic equation calculation is as follows:
- 4 $ERP/EIRP (dBm) = SG \text{ Setting}(dBm) + Antenna \text{ Gain} (dB/dBi) - Cable \text{ loss} (dB)$

Radiated Spurious Emission Measurement Result: GSM 850 Mode

Operation Mode	: TX CH High E2 Mode	Test Date:	Feb. 13, 2008
Fundamental Frequency	: 848.80 MHz	Test By:	Bondi
Temperature	: 25	Pol:	Ver
Humidity	: 65%		

Freq. (MHz)	SPA. Reading (dBuV)	Ant.Pol. H/V	S.G Output (dBm)	Antenna Gain (dB/dBi)	Cable Loss (dB)	ERP/EIRP (dBm)	Limit (dBm)	Safe Margin (dBm)
41.64	44.02	V	-58.63	-2.31	0.80	-61.75	-13.00	-48.75
101.78	46.51	V	-56.97	-7.76	1.23	-65.96	-13.00	-52.96
850.00	73.70	V	-13.01	-7.88	3.75	-24.64	-13.00	-11.64
1697.60	60.54	V	-46.48	9.44	5.14	-42.19	-13.00	-29.19
2546.40	59.11	V	-44.68	10.20	6.40	-40.88	-13.00	-27.88
3395.20	---	V		12.38	7.33		-13.00	
4244.00	---	V		12.63	8.46		-13.00	
5092.80	---	V		12.74	9.32		-13.00	
5941.60	---	V		13.81	9.89		-13.00	
6790.40	---	V		11.86	10.87		-13.00	
7639.20	---	V		11.40	11.48		-13.00	
8488.00	---	V		11.70	12.59		-13.00	

Measurement uncertainty	30MHz - 80MHz: 5.04dB
	80MHz -1000MHz: 3.76dB
	1GHz - 13GHz: 4.45dB

Remark :

- 1 The emission behaviors belong to narrowband spurious emission.
- 2 Remark"---" means that the emission level is too low to be measured
- 3 The result basic equation calculation is as follows:
- 4 $ERP/EIRP (dBm) = SG \text{ Setting}(dBm) + Antenna \text{ Gain} (dB/dBi) - Cable \text{ loss} (dB)$

Radiated Spurious Emission Measurement Result: GSM 850 Mode

Operation Mode	: TX CH High E2 Mode	Test Date:	Feb. 13, 2008
Fundamental Frequency	: 848.80 MHz	Test By:	Bondi
Temperature	: 25	Pol:	Hor
Humidity	: 65%		

Freq. (MHz)	SPA. Reading (dBuV)	Ant.Pol. H/V	S.G Output (dBm)	Antenna Gain (dB/dBi)	Cable Loss (dB)	ERP/EIRP (dBm)	Limit (dBm)	Safe Margin (dBm)
36.79	46.52	H	-57.28	-4.16	0.75	-62.18	-13.00	-49.18
65.89	45.50	H	-66.35	-0.83	0.98	-68.16	-13.00	-55.16
850.00	78.80	H	-8.19	-7.88	3.75	-19.82	-13.00	-6.82
1697.60	58.62	H	-48.36	9.44	5.14	-44.07	-13.00	-31.07
2546.40	51.44	H	-52.34	10.20	6.40	-48.54	-13.00	-35.54
3395.20	---	H		12.38	7.33		-13.00	
4244.00	---	H		12.63	8.46		-13.00	
5092.80	---	H		12.74	9.32		-13.00	
5941.60	---	H		13.81	9.89		-13.00	
6790.40	---	H		11.86	10.87		-13.00	
7639.20	---	H		11.40	11.48		-13.00	
8488.00	---	H		11.70	12.59		-13.00	

Measurement uncertainty	30MHz - 80MHz: 5.04dB
	80MHz -1000MHz: 3.76dB
	1GHz - 13GHz: 4.45dB

Remark :

- 1 The emission behaviors belong to narrowband spurious emission.
- 2 Remark"---" means that the emission level is too low to be measured
- 3 The result basic equation calculation is as follows:
- 4 $ERP/EIRP (dBm) = SG \text{ Setting}(dBm) + Antenna \text{ Gain} (dB/dBi) - Cable \text{ loss} (dB)$

Radiated Spurious Emission Measurement Result: PCS 1900 Mode

Operation Mode	: TX CH Low E1 Mode	Test Date:	Feb. 13, 2008
Fundamental Frequency	: 1850.20MHz	Test By:	Bondi
Temperature	: 25	Pol:	Ver
Humidity	: 65%		

Freq. (MHz)	SPA. Reading (dBuV)	Ant.Pol. H/V	S.G Out-put (dBm)	Antenna Gain (dB/dBi)	Cable Loss (dB)	ERP/EIRP (dBm)	Limit (dBm)	Safe Margin (dBm)
41.64	44.41	V	-58.24	-2.31	0.80	-61.36	-13.00	-48.36
101.78	47.27	V	-56.21	-7.76	1.23	-65.20	-13.00	-52.20
1850.00	82.46	V	-24.50	9.90	5.41	-20.01	-13.00	-7.01
3700.40	---	V		12.61	7.73		-13.00	
5550.60	39.78	V	-55.43	13.23	9.68	-51.89	-13.00	-38.89
7400.80	---	V		11.50	11.28		-13.00	
9251.00	---	V		11.92	13.10		-13.00	
11101.20	---	V		11.66	14.33		-13.00	
12951.40	---	V		13.63	15.98		-13.00	
14801.60	---	V		12.76	17.27		-13.00	
16651.80	---	V		15.92	19.04		-13.00	
18502.00	---	V		18.75	21.21		-13.00	

Measurement uncertainty	30MHz - 80MHz: 5.04dB
	80MHz - 1000MHz: 3.76dB
	1GHz - 13GHz: 4.45dB

Remark :

- 1 The emission behaviors belong to narrowband spurious emission.
- 2 Remark"---" means that the emission level is too low to be measured
- 3 The result basic equation calculation is as follows:
- 4 $ERP/EIRP (dBm) = SG \text{ Setting}(dBm) + Antenna \text{ Gain} (dB/dBi) - Cable \text{ loss} (dB)$

Radiated Spurious Emission Measurement Result: PCS 1900 Mode

Operation Mode	: TX CH Low E1 Mode	Test Date:	Feb. 13, 2008
Fundamental Frequency	: 1850.20MHz	Test By:	Bondi
Temperature	: 25	Pol:	Hor
Humidity	: 65%		

Freq. (MHz)	SPA. Reading (dBuV)	Ant.Pol. H/V	S.G Out-put (dBm)	Antenna Gain (dB/dBi)	Cable Loss (dB)	ERP/EIRP (dBm)	Limit (dBm)	Safe Margin (dBm)
43.58	43.55	H	-60.79	-1.92	0.83	-63.53	-13.00	-50.53
101.78	42.14	H	-60.90	-7.76	1.23	-69.88	-13.00	-56.88
1850.00	78.19	H	-28.70	9.90	5.41	-24.21	-13.00	-11.21
3700.40	---	H		12.61	7.73		-13.00	
5550.60	36.10	H	-59.03	13.23	9.68	-55.48	-13.00	-42.48
7400.80	---	H		11.50	11.28		-13.00	
9251.00	---	H		11.92	13.10		-13.00	
11101.20	---	H		11.66	14.33		-13.00	
12951.40	---	H		13.63	15.98		-13.00	
14801.60	---	H		12.76	17.27		-13.00	
16651.80	---	H		15.92	19.04		-13.00	
18502.00	---	H		18.75	21.21		-13.00	

Measurement uncertainty	30MHz - 80MHz: 5.04dB
	80MHz - 1000MHz: 3.76dB
	1GHz - 13GHz: 4.45dB

Remark :

- 1 The emission behaviors belong to narrowband spurious emission.
- 2 Remark"---" means that the emission level is too low to be measured
- 3 The result basic equation calculation is as follows:
- 4 $ERP/EIRP (dBm) = SG \text{ Setting}(dBm) + Antenna \text{ Gain} (dB/dBi) - Cable \text{ loss} (dB)$

Radiated Spurious Emission Measurement Result: PCS 1900 Mode

Operation Mode	: TX CH Mid E1 Mode	Test Date:	Feb. 13, 2008
Fundamental Frequency	: 1880MHz	Test By:	Bondi
Temperature	: 25	Pol:	Ver
Humidity	: 65%		

Freq. (MHz)	SPA. Reading (dBuV)	Ant.Pol. H/V	S.G Out-put (dBm)	Antenna Gain (dB/dBi)	Cable Loss (dB)	ERP/EIRP (dBm)	Limit (dBm)	Safe Margin (dBm)
43.58	44.55	V	-59.11	-1.92	0.83	-61.85	-13.00	-48.85
101.78	47.89	V	-55.59	-7.76	1.23	-64.58	-13.00	-51.58
3760.00	41.55	V	-59.75	12.60	7.82	-54.97	-13.00	-41.97
5640.00	37.85	V	-57.11	13.36	9.73	-53.48	-13.00	-40.48
7520.00	---	V		11.45	11.33		-13.00	
9400.00	---	V		11.93	13.15		-13.00	
11280.00	---	V		11.92	14.56		-13.00	
13160.00	---	V		13.33	16.11		-13.00	
15040.00	---	V		13.76	17.57		-13.00	
16920.00	---	V		15.27	19.66		-13.00	
18800.00	---	V		18.68	21.34		-13.00	

Measurement uncertainty	30MHz - 80MHz: 5.04dB
	80MHz -1000MHz: 3.76dB
	1GHz - 13GHz: 4.45dB

Remark :

- 1 The emission behaviors belong to narrowband spurious emission.
- 2 Remark"---" means that the emission level is too low to be measured
- 3 The result basic equation calculation is as follows:
- 4 $ERP/EIRP (dBm) = SG \text{ Setting}(dBm) + Antenna \text{ Gain} (dB/dBi) - Cable \text{ loss} (dB)$

Radiated Spurious Emission Measurement Result: PCS 1900 Mode

Operation Mode	: TX CH Mid E1 Mode	Test Date:	Feb. 13, 2008
Fundamental Frequency	: 1880MHz	Test By:	Bondi
Temperature	: 25	Pol:	Hor
Humidity	: 65%		

Freq. (MHz)	SPA. Reading (dBuV)	Ant.Pol. H/V	S.G Out-put (dBm)	Antenna Gain (dB/dBi)	Cable Loss (dB)	ERP/EIRP (dBm)	Limit (dBm)	Safe Margin (dBm)
41.64	44.22	H	-59.29	-2.31	0.80	-62.40	-13.00	-49.40
101.78	42.19	H	-60.85	-7.76	1.23	-69.83	-13.00	-56.83
3760.00	38.22	H	-62.89	12.60	7.82	-58.10	-13.00	-45.10
5640.00	35.60	H	-59.29	13.36	9.73	-55.66	-13.00	-42.66
7520.00	---	H		11.45	11.33		-13.00	
9400.00	---	H		11.93	13.15		-13.00	
11280.00	---	H		11.92	14.56		-13.00	
13160.00	---	H		13.33	16.11		-13.00	
15040.00	---	H		13.76	17.57		-13.00	
16920.00	---	H		15.27	19.66		-13.00	
18800.00	---	H		18.68	21.34		-13.00	

Measurement uncertainty	30MHz - 80MHz: 5.04dB
	80MHz -1000MHz: 3.76dB
	1GHz - 13GHz: 4.45dB

Remark :

- 1 The emission behaviors belong to narrowband spurious emission.
- 2 Remark"---" means that the emission level is too low to be measured
- 3 The result basic equation calculation is as follows:
- 4 $ERP/EIRP (dBm) = SG \text{ Setting}(dBm) + Antenna \text{ Gain} (dB/dBi) - Cable \text{ loss} (dB)$

Radiated Spurious Emission Measurement Result: PCS 1900 Mode

Operation Mode	: TX CH High E1 Mode	Test Date:	Feb. 13, 2008
Fundamental Frequency	: 1909.8 MHz	Test By:	Bondi
Temperature	: 25	Pol:	Ver
Humidity	: 65%		

Freq. (MHz)	SPA. Reading (dBuV)	Ant.Pol. H/V	S.G Out-put (dBm)	Antenna Gain (dB/dBi)	Cable Loss (dB)	ERP/EIRP (dBm)	Limit (dBm)	Safe Margin (dBm)
41.64	43.63	V	-59.02	-2.31	0.80	-62.14	-13.00	-49.14
101.78	48.01	V	-55.47	-7.76	1.23	-64.46	-13.00	-51.46
1910.00	74.60	V	-32.34	10.08	5.51	-27.77	-13.00	-14.77
3981.60	41.11	V	-59.17	12.60	8.17	-54.75	-13.00	-41.75
5972.40	35.39	V	-58.63	13.86	9.91	-54.68	-13.00	-41.68
7963.20	---	V		11.27	11.88		-13.00	
9954.00	---	V		12.08	13.43		-13.00	
11944.80	---	V		13.08	15.21		-13.00	
13935.60	---	V		11.82	16.86		-13.00	
15926.40	---	V		17.08	18.33		-13.00	
17917.20	---	V		9.63	20.12		-13.00	
19908.00	---	V		18.88	20.85		-13.00	

Measurement uncertainty	30MHz - 80MHz: 5.04dB
	80MHz -1000MHz: 3.76dB
	1GHz - 13GHz: 4.45dB

Remark :

- 1 The emission behaviors belong to narrowband spurious emission.
- 2 Remark"---" means that the emission level is too low to be measured
- 3 The result basic equation calculation is as follows:
- 4 $ERP/EIRP (dBm) = SG \text{ Setting}(dBm) + Antenna \text{ Gain} (dB/dBi) - Cable \text{ loss} (dB)$

Radiated Spurious Emission Measurement Result: PCS 1900 Mode

Operation Mode : TX CH High E1 Mode Test Date: Feb. 13, 2008
 Fundamental Frequency : 1909.8 MHz Test By: Bondi
 Temperature : 25 Pol: Hor
 Humidity : 65%

Freq. (MHz)	SPA. Reading (dBuV)	Ant.Pol. H/V	S.G Output (dBm)	Antenna Gain (dB/dBi)	Cable Loss (dB)	ERP/EIRP (dBm)	Limit (dBm)	Safe Margin (dBm)
40.67	42.52	H	-60.57	-2.51	0.79	-63.87	-13.00	-50.87
101.78	42.64	H	-60.40	-7.76	1.23	-69.38	-13.00	-56.38
1910.00	79.61	H	-27.24	10.08	5.51	-22.68	-13.00	-9.68
3981.60	37.26	H	-62.92	12.60	8.17	-58.49	-13.00	-45.49
5972.40	37.26	H	-56.75	13.86	9.91	-52.80	-13.00	-39.80
7963.20	---	H		11.27	11.88		-13.00	
9954.00	---	H		12.08	13.43		-13.00	
11944.80	---	H		13.08	15.21		-13.00	
13935.60	---	H		11.82	16.86		-13.00	
15926.40	---	H		17.08	18.33		-13.00	
17917.20	---	H		9.63	20.12		-13.00	
19908.00	---	H		18.88	20.85		-13.00	

Measurement uncertainty	30MHz - 80MHz: 5.04dB
	80MHz -1000MHz: 3.76dB
	1GHz - 13GHz: 4.45dB

Remark :

- 1 The emission behaviors belong to narrowband spurious emission.
- 2 Remark"---" means that the emission level is too low to be measured
- 3 The result basic equation calculation is as follows:
- 4 $ERP/EIRP (dBm) = SG \text{ Setting}(dBm) + Antenna \text{ Gain} (dB/dBi) - Cable \text{ loss} (dB)$

10. FREQUENCY STABILITY V.S. TEMPERATURE MEASUREMENT

10.1 Standard Applicable

According to FCC §2.1055(a)(1)(b).

Frequency Tolerance: 2.5 ppm

10.2: Test Set-up:

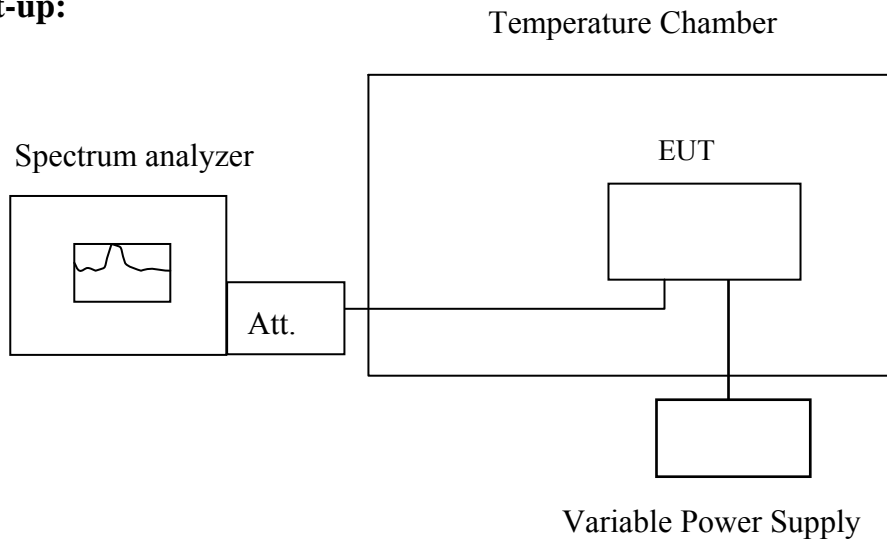

Note : Measurement setup for testing on Antenna connector

10.3 Measurement Procedure

The equipment under test was connected to an external AC or DC power supply and input rated voltage. RF output was connected to a frequency counter or spectrum analyzer via feed through attenuators. The EUT was placed inside the temperature chamber. Set the spectrum analyzer RBW low enough to obtain the desired frequency resolution and measure EUT 25°C operating frequency as reference frequency. Turn EUT off and set the chamber temperature to -30°C. After the temperature stabilized for approximately 30 minutes re-recorded the frequency. Repeat step measure with 10°C increased per stage until the highest temperature of +50°C reached.

10.4 Measurement Equipment Used:

Conducted Emission Test Site					
EQUIPMENT TYPE	MFR	MODEL NUMBER	SERIAL NUMBER	LAST CAL.	CAL DUE.
Spectrum Analyzer	Agilent	E4446A	MY43360126	04/27/2007	04/27/2008
Spectrum Analyzer	Agilent	E7405A	US41160416	07/04/2007	07/03/2008
Spectrum Analyzer	R&S	FSP 40	100034	01/05/2008	01/04/2009
Communication Test	R&S	SMU200	N/A	N/A	N/A
Power Sensor	Anritsu	MA2490A	31431	07/07/2007	07/06/2008
Power Meter	Anritsu	ML2487A	6K00002070	07/07/2007	07/06/2008
Temperature Chamber	TERCHY	MHG-120LF	911009	04/26/2007	04/25/2008
Low Loss Cable	HUBER+SUHNER	SUCOFLEX 104PEA	N/A	N/A	N/A
Attenuator	Mini-Circuit	BW-S10W5	N/A	07/05/2007	07/04/2008
Attenuator	Mini-Circuit	BW-S6W5	N/A	07/05/2007	07/04/2008
Splitter	Agilent	11636B	51728	07/05/2007	07/04/2008
DC Power Supply	Agilent	6038A	2929A-07548	06/27/2007	06/26/2008

This document is issued by the Company subject to its General Conditions of Service printed overleaf or available on request and accessible at www.sgs.com. Attention is drawn to the limitations of liability, indemnification, and Jurisdictional issued defined therein. Unless otherwise stated, the results shown in this test report refer only to the sample(s) tested. This document cannot be reproduced except in full, without prior approval of Company. Any unauthorized alteration, forgery or falsification of the content or appearance of this report is unlawful and offenders may be prosecuted to the fullest extent of the law. 此報告是遵循本公司訂定之通用服務條款所製作發放，請注意此條款列印於背面，亦可在www.sgs.com中查閱。將本公司之義務，免責，管轄權皆明確規範之。除非另有說明，此報告結果僅對檢驗之樣品負責。本報告未經本公司書面許可，不可部份複製。對本報告內容或外觀之任何未經授權之變更、偽造、竄改皆屬非法，違犯者將會被依法追訴。

10.5 Measurement Result

Reference Frequency: GSM Mid Channel 836.6 MHz @ 25°C				
Limit: +/- 0.1 ppm = 83.6 Hz				
Power Supply	Environment	Frequency	Delta (Hz)	Limit (Hz)
Vdc	Temperature (°C)	(MHz)		
3.7	-30	836.599983	6.00	83.6
3.7	-20	836.599981	8.00	83.6
3.7	-10	836.599978	11.00	83.6
3.7	0	836.599992	-3.00	83.6
3.7	10	836.599979	10.00	83.6
3.7	20	836.599989	0.00	83.6
3.7	30	836.599993	-4.00	83.6
3.7	40	836.599985	4.00	83.6
3.7	50	836.599979	10.00	83.6

Reference Frequency: PCS Mid Channel 1880 MHz @ 25°C				
Limit: +/- 0.04 ppm = 75.2 Hz				
Power Supply	Environment	Frequency	Delta (Hz)	Limit (Hz)
Vdc	Temperature (°C)	(MHz)		
3.7	-30	1879.999963	-4.00	75.2
3.7	-20	1879.999951	8.00	75.2
3.7	-10	1879.999970	-11.00	75.2
3.7	0	1879.999964	-5.00	75.2
3.7	10	1879.999978	-19.00	75.2
3.7	20	1879.999959	0.00	75.2
3.7	30	1879.999969	-10.00	75.2
3.7	40	1879.999981	-22.00	75.2
3.7	50	1879.999963	-4.00	75.2

Note: The battery is rated 3.7V dc.

11. FREQUENCY STABILITY V.S. VOLTAGE MEASUREMENT

11.1 Standard Applicable

According to FCC §2.1055(d)(1)(2)

Frequency Tolerance: 2.5 ppm

11.2 Test Set-up:

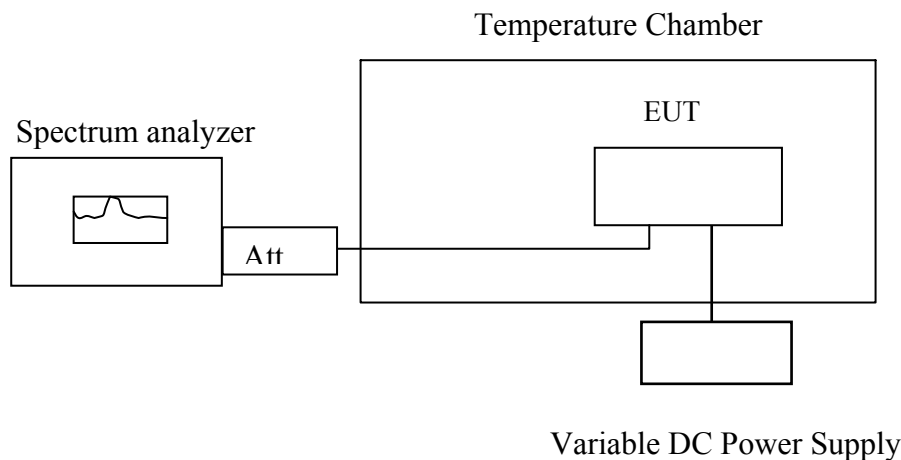

Note: Measurement setup for testing on Antenna connector

11.3 Measurement Procedure

Set chamber temperature to 25°C. Use a variable AC power supply / DC power source to power the EUT and set the voltage to rated voltage. Set the spectrum analyzer RBW low enough to obtain the desired frequency resolution and recorded the frequency.

Reduce the input voltage to specified extreme voltage variation (+/- 15%) and endpoint, record the maximum frequency change.

11.4 Measurement Equipment Used:

Conducted Emission Test Site					
EQUIPMENT TYPE	MFR	MODEL NUMBER	SERIAL NUMBER	LAST CAL.	CAL DUE.
Spectrum Analyzer	Agilent	E4446A	MY43360126	04/27/2007	04/27/2008
Spectrum Analyzer	Agilent	E7405A	US41160416	07/04/2007	07/03/2008
Spectrum Analyzer	R&S	FSP 40	100034	01/05/2008	01/04/2009
Communication Test	R&S	SMU200	N/A	N/A	N/A
Power Sensor	Anritsu	MA2490A	31431	07/07/2007	07/06/2008
Power Meter	Anritsu	ML2487A	6K00002070	07/07/2007	07/06/2008
Temperature Chamber	TERCHY	MHG-120LF	911009	04/26/2007	04/25/2008
Low Loss Cable	HUBER+SUHNER	SUCOFLEX 104PEA	N/A	N/A	N/A
Attenuator	Mini-Circuit	BW-S10W5	N/A	07/05/2007	07/04/2008
Attenuator	Mini-Circuit	BW-S6W5	N/A	07/05/2007	07/04/2008
Splitter	Agilent	11636B	51728	07/05/2007	07/04/2008
DC Power Supply	Agilent	6038A	2929A-07548	06/27/2007	06/26/2008

This document is issued by the Company subject to its General Conditions of Service printed overleaf or available on request and accessible at www.sgs.com. Attention is drawn to the limitations of liability, indemnification, and Jurisdictional issued defined therein. Unless otherwise stated, the results shown in this test report refer only to the sample(s) tested. This document cannot be reproduced except in full, without prior approval of Company. Any unauthorized alteration, forgery or falsification of the content or appearance of this report is unlawful and offenders may be prosecuted to the fullest extent of the law. 此報告是遵循本公司訂定之通用服務條款所製作發放，請注意此條款列印於背面，亦可在www.sgs.com中查閱。將本公司之義務，免責，管轄權皆明確規範之。除非另有說明，此報告結果僅對檢驗之樣品負責。本報告未經本公司書面許可，不可部份複製。對本報告內容或外觀之任何未經授權之變更、偽造、竄改皆屬非法，違犯者將會被依法追訴。

11.5 Measurement Result

Reference Frequency: GSM Mid Channel 836.6 MHz @ 25°C				
Limit: +/- 0.1 ppm = 83.6 Hz				
Power Supply	Environment	Frequency	Delta (Hz)	Limit (Hz)
Vdc	Temperature (°C)	(MHz)		
4.20	25.00	836.599987	0.00	83.6
3.70	25.00	836.599989	-2.00	83.6
2.9 (End Point)	25.00	836.599963	24.00	83.6

Reference Frequency: PCS Mid Channel 1880 MHz @ 25°C				
Limit: +/- 0.04 ppm = 75.2 Hz				
Power Supply	Environment	Frequency	Delta (Hz)	Limit (Hz)
Vdc	Temperature (°C)	(MHz)		
4.20	25	1879.999968	0.00	75.2
3.70	25	1879.999959	9.00	75.2
2.9 (End Point)	25	1879.999915	53.00	75.2

Note: The battery is rated 3.7V dc.

12. AC POWER LINE CONDUCTED EMISSION TEST

12.1 Standard Applicable

According to §15.207. The emission value for frequency within 150KHz to 30MHz shall not exceed criteria of below chart.

Frequency range MHz	Limits dB(uV)	
	Quasi-peak	Average
0.15 to 0.50	66 to 56	56 to 46
0.50 to 5	56	46
5 to 30	60	50

Note

- 1.The lower limit shall apply at the transition frequencies
- 2.The limit decreases linearly with the logarithm of the frequency in the range 0.15 MHz to 0.50 MHz.

12.2 EUT Setup

1. The conducted emission tests were performed in the test site, using the setup in accordance with the ANSI C63.4-2001.
2. The EUT was plug-in DC power adaptor and was placed on the center of the back edge on the test table. The peripherals like earphone was placed on the side of the EUT. The rear of the EUT and peripherals were placed flushed with the rear of the tabletop.
3. The Power adaptor was connected with 110Vac/60Hz power source.

12.3 Measurement Procedure

1. The EUT was placed on a table which is 0.8m above ground plane.
2. Maximum procedure was performed on the six highest emissions to ensure EUT compliance.
3. Repeat above procedures until all frequency measured were complete.

12.4 Measurement Equipment Used:

Conducted Emission Test Site					
EQUIPMENT TYPE	MFR	MODEL NUMBER	SERIAL NUMBER	LAST CAL.	CAL DUE.
EMC Analyzer	HP	8594EM	3624A00203	09/02/2007	09/03/2008
EMI Test Receiver	R&S	ESCS30	828985/004	06/09/2007	06/10/2008
Transient Limiter	HP	11947A	3107A02062	09/02/2007	09/03/2008
LISN	Rolf-Heine	NNB-2/16Z	99012	01/10/2008	01/09/2009
LISN	Rolf-Heine	NNB-2/16Z	99013	01/10/2008	01/09/2009
Coaxial Cables	N/A	No. 3, 4	N/A	12/01/2007	11/30/2008

12.5 Measurement Result

The initial step in collecting conducted data is a spectrum analyzer peak scan of the measurement range. Significant peaks are then marked as shown on the following data page, and these signals are then quasi-peaked.

AC POWER LINE CONDUCTED EMISSION TEST DATA

Operation Mode:	GSM 850 LINK + AC Adapter (DELTA)	Test Date:	Feb. 14, 2008
Temperature:	25 °C	Humidity:	59 %
		Test By:	Bondi

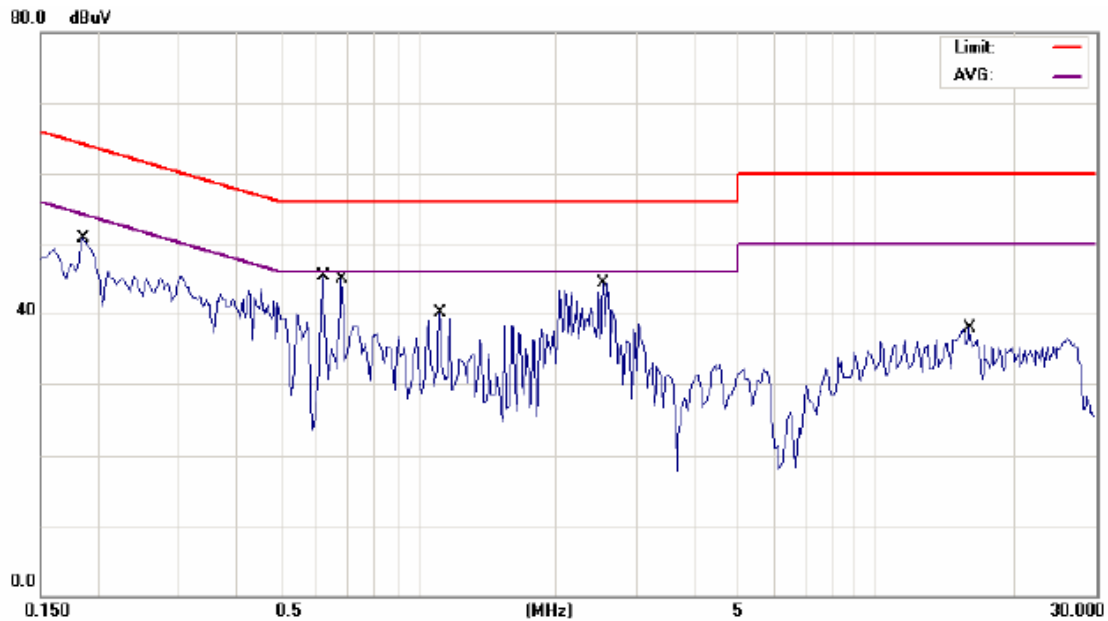

Site: SGS CONDUCTED #1
 Limit: CISPR22 Class B Conduction(QP)
 EUT: Mobile
 M/N: kais 140 2nd pa
 Note: GSM 850 Link / charger mode (DELTA)

Phase: L1
 Power: AC 120V/60Hz
 Distance:

Temperature: 24 °C
 Humidity: 62 %
 Air Pressure: hpa

No.	Mk.	Freq. MHz	Reading Level dBuV	Factor dB	Measure- ment dBuV	Limit dBuV	Over dB	Detector	Comment
1		0.1850	50.26	0.50	50.76	64.26	-13.50	QP	
2	*	0.6200	44.54	0.69	45.23	56.00	-10.77	QP	
3		0.6200	31.00	0.69	31.69	46.00	-14.31	AVG	
4		0.6800	44.21	0.71	44.92	56.00	-11.08	QP	
5		0.6800	30.00	0.71	30.71	46.00	-15.29	AVG	
6		1.1150	39.26	0.81	40.07	56.00	-15.93	QP	
7		2.5400	43.44	0.88	44.32	56.00	-11.68	QP	
8		2.5400	23.00	0.88	23.88	46.00	-22.12	AVG	
9		16.0400	36.76	1.19	37.95	60.00	-22.05	QP	

This document is issued by the Company subject to its General Conditions of Service printed overleaf or available on request and accessible at www.sgs.com. Attention is drawn to the limitations of liability, indemnification, and Jurisdictional issued defined therein. Unless otherwise stated, the results shown in this test report refer only to the sample(s) tested. This document cannot be reproduced except in full, without prior approval of Company. Any unauthorized alteration, forgery or falsification of the content or appearance of this report is unlawful and offenders may be prosecuted to the fullest extent of the law. 此報告是遵循本公司訂定之通用服務條款所製作發放，請注意此條款列印於背面，亦可在www.sgs.com中查閱。將本公司之義務，免責，管轄權皆明確規範之。除非另有說明，此報告結果僅對檢驗之樣品負責。本報告未經本公司書面許可，不可部份複製。對本報告內容或外觀之任何未經授權之變更、偽造、竄改皆屬非法，違犯者將會被依法追訴。

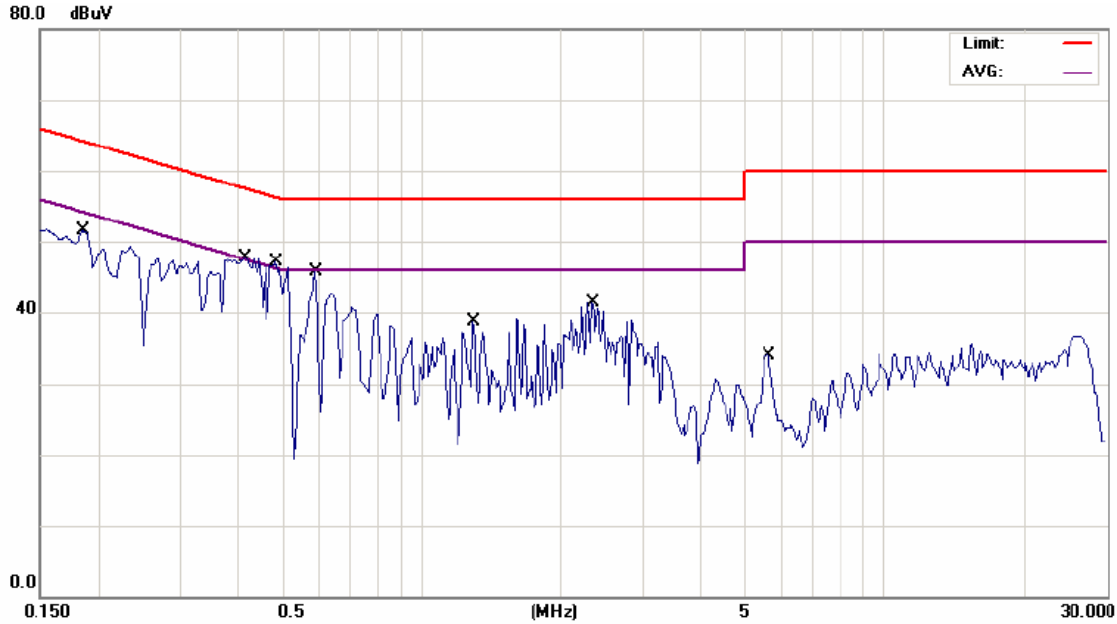

Site SGS CONDUCTED #1 Phase: **N** Temperature: 24 °C
 Limit: CISPR22 Class B Conduction(QP) Power: AC 120V/60Hz Humidity: 62 %
 EUT: Mobile Distance: Air Pressure: hpa
 M/N: kais 140 2nd pa
 Note: GSM 850 Link / charger mode (DELTA)

No.	Mk.	Freq. MHz	Reading Level dBuV	Factor dB	Measure- ment dBuV	Limit dBuV	Over dB	Detector	Comment
1		0.1850	50.93	0.50	51.43	64.26	-12.83	QP	
2		0.4150	47.12	0.63	47.75	57.55	-9.80	QP	
3		0.4150	28.00	0.63	28.63	47.55	-18.92	AVG	
4	*	0.4850	46.36	0.65	47.01	56.25	-9.24	QP	
5		0.4850	27.00	0.65	27.65	46.25	-18.60	AVG	
6		0.5900	45.02	0.68	45.70	56.00	-10.30	QP	
7		0.5900	26.00	0.68	26.68	46.00	-19.32	AVG	
8		1.2950	37.91	0.85	38.76	56.00	-17.24	QP	
9		2.3450	40.36	0.96	41.32	56.00	-14.68	QP	
10		5.6200	33.08	1.12	34.20	60.00	-25.80	QP	

This document is issued by the Company subject to its General Conditions of Service printed overleaf or available on request and accessible at www.sgs.com. Attention is drawn to the limitations of liability, indemnification, and Jurisdictional issued defined therein. Unless otherwise stated, the results shown in this test report refer only to the sample(s) tested. This document cannot be reproduced except in full, without prior approval of Company. Any unauthorized alteration, forgery or falsification of the content or appearance of this report is unlawful and offenders may be prosecuted to the fullest extent of the law. 此報告是遵循本公司訂定之通用服務條款所製作發放。請注意此條款列印於背面，亦可在www.sgs.com中查閱。將本公司之義務，免責，管轄權皆明確規範之。除非另有說明，此報告結果僅對檢驗之樣品負責。本報告未經本公司書面許可，不可部份複製。對本報告內容或外觀之任何未經授權之變更、偽造、竄改皆屬非法，違犯者將會被依法追訴。

AC POWER LINE CONDUCTED EMISSION TEST DATA

Operation Mode:	GSM 850 LINK + AC Adapter (PHIHONG)		Test Date:	Feb. 14, 2008	
Temperature:	25 °C	Humidity:	59 %	Test By:	Jazz

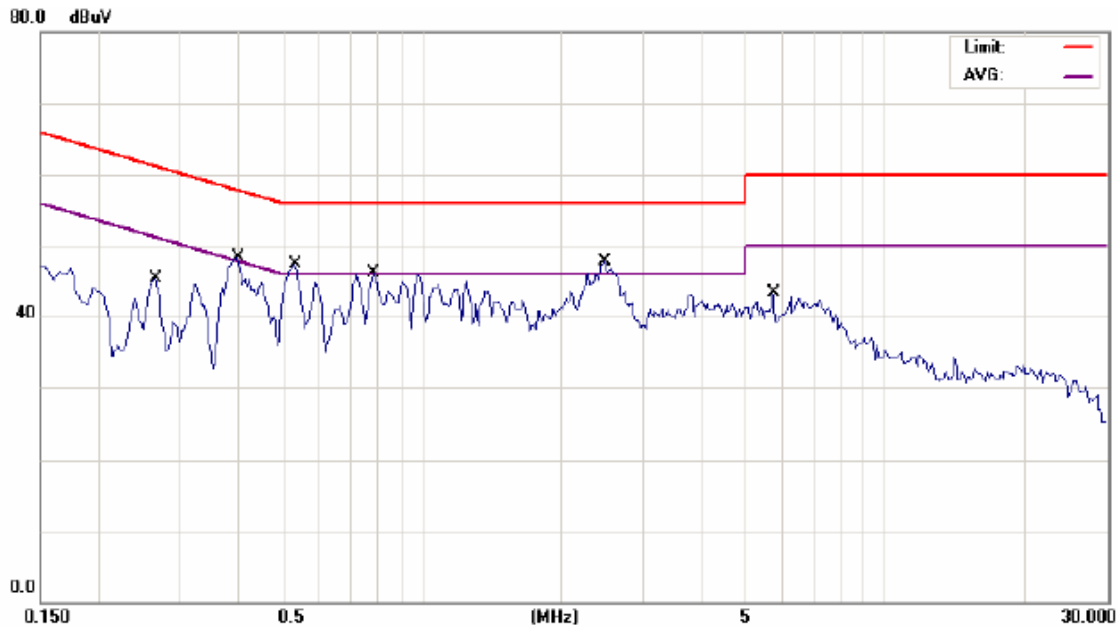

Site SGS CONDUCTED #1 Phase: **L1** Temperature: 24 °C
 Limit: CISPR22 Class B Conduction(QP) Power: AC 120V/60Hz Humidity: 62 %
 EUT: Mobile Distance: Air Pressure: hpa
 M/N: kais 140 2nd pa
 Note: GSM 850 Link / charger mode (PHIHONG)

No.	Mk.	Freq. MHz	Reading Level dBuV	Factor dB	Measure- ment dBuV	Limit dBuV	Over dB	Detector	Comment
1		0.2650	44.76	0.55	45.31	61.27	-15.96	QP	
2		0.4000	47.65	0.62	48.27	57.85	-9.58	QP	
3		0.4000	36.00	0.62	36.62	47.85	-11.23	AVG	
4		0.5300	46.71	0.66	47.37	56.00	-8.63	QP	
5		0.5300	33.00	0.66	33.66	46.00	-12.34	AVG	
6		0.7850	45.45	0.74	46.19	56.00	-9.81	QP	
7		0.7850	29.00	0.74	29.74	46.00	-16.26	AVG	
8	*	2.4800	46.93	0.87	47.80	56.00	-8.20	QP	
9		2.4800	31.00	0.87	31.87	46.00	-14.13	AVG	
10		5.7400	42.31	1.03	43.34	60.00	-16.66	QP	

This document is issued by the Company subject to its General Conditions of Service printed overleaf or available on request and accessible at www.sgs.com. Attention is drawn to the limitations of liability, indemnification, and Jurisdictional issued defined therein. Unless otherwise stated, the results shown in this test report refer only to the sample(s) tested. This document cannot be reproduced except in full, without prior approval of Company. Any unauthorized alteration, forgery or falsification of the content or appearance of this report is unlawful and offenders may be prosecuted to the fullest extent of the law. 此報告是遵循本公司訂定之通用服務條款所製作發放，請注意此條款列印於背面，亦可在www.sgs.com中查閱。將本公司之義務，免責，管轄權皆明確規範之。除非另有說明，此報告結果僅對檢驗之樣品負責。本報告未經本公司書面許可，不可部份複製。對本報告內容或外觀之任何未經授權之變更、偽造、竄改皆屬非法，違犯者將會被依法追訴。

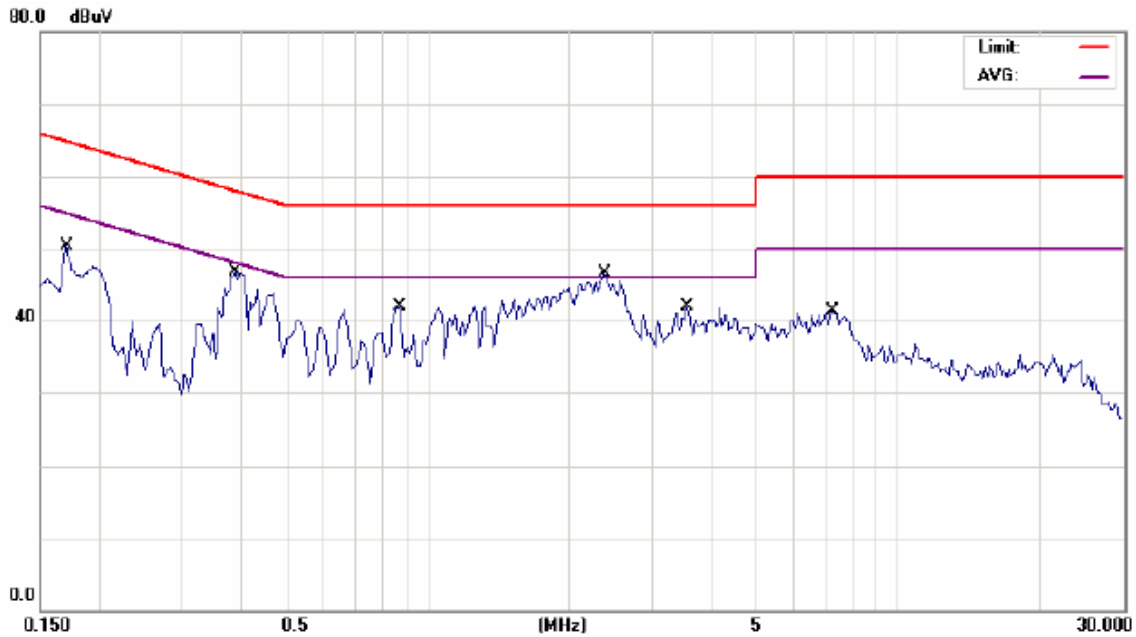

Site SGS CONDUCTED #1

Phase: **N**

Temperature: 24 °C

Limit: CISPR22 Class B Conduction(QP)

Power: AC 120V/60Hz

Humidity: 62 %

EUT: Mobile

Distance:

Air Pressure: hpa

M/N: kais 140 2nd pa

Note: GSM 850 Link / charger mode (PHIHONG)

No.	Mk.	Freq. MHz	Reading Level dBuV	Factor dB	Measure- ment dBuV	Limit dBuV	Over dB	Detector	Comment
1		0.1700	49.75	0.48	50.23	64.96	-14.73	QP	
2		0.3900	46.04	0.61	46.65	58.06	-11.41	QP	
3		0.3900	32.00	0.61	32.61	48.06	-15.45	AVG	
4		0.8750	41.08	0.77	41.85	56.00	-14.15	QP	
5	*	2.3750	45.44	0.97	46.41	56.00	-9.59	QP	
6		2.3750	30.00	0.97	30.97	46.00	-15.03	AVG	
7		3.5600	40.87	1.04	41.91	56.00	-14.09	QP	
8		7.2400	40.10	1.17	41.27	60.00	-18.73	QP	

This document is issued by the Company subject to its General Conditions of Service printed overleaf or available on request and accessible at www.sgs.com. Attention is drawn to the limitations of liability, indemnification, and Jurisdictional issued defined therein. Unless otherwise stated, the results shown in this test report refer only to the sample(s) tested. This document cannot be reproduced except in full, without prior approval of Company. Any unauthorized alteration, forgery or falsification of the content or appearance of this report is unlawful and offenders may be prosecuted to the fullest extent of the law. 此報告是遵循本公司訂定之通用服務條款所製作發放，請注意此條款列印於背面，亦可在www.sgs.com中查閱。將本公司之義務，免責，管轄權皆明確規範之。除非另有說明，此報告結果僅對檢驗之樣品負責。本報告未經本公司書面許可，不可部份複製。對本報告內容或外觀之任何未經授權之變更、偽造、竄改皆屬非法，違犯者將會被依法追訴。

AC POWER LINE CONDUCTED EMISSION TEST DATA

Operation Mode:	GSM 1900 Link + AC Adapter(DELTA)	Test Date:	Feb. 14, 2008
Temperature:	25 °C	Humidity:	59 %
		Test By:	Bondi

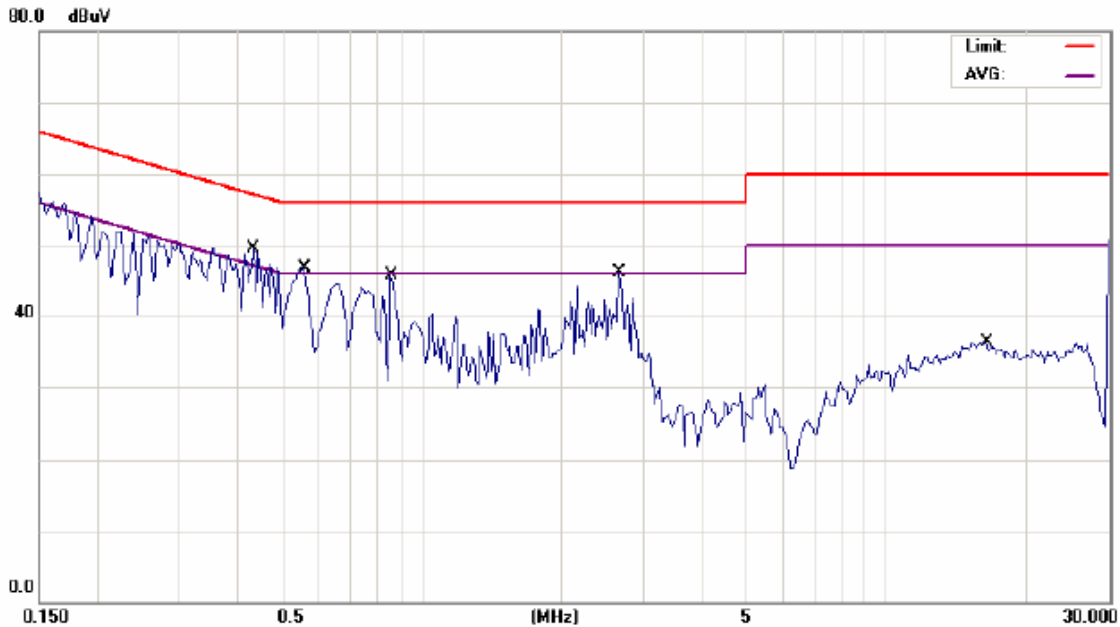

Site SGS CONDUCTED #1 Phase: **L1** Temperature: 24 °C
 Limit: CISPR22 Class B Conduction(QP) Power: AC 120V/60Hz Humidity: 62 %
 EUT: Mobile Distance: Air Pressure: hpa
 M/N: kais 140 2nd pa
 Note: GSM 1900 Link / charger mode (DELTA)

No.	Mk.	Freq. MHz	Reading Level dBµV	Factor dB	Measure- ment dBµV	Limit dBµV	Over dB	Detector	Comment
1	*	0.4350	49.44	0.02	49.46	57.16	-7.70	QP	
2		0.4350	24.00	0.02	24.02	47.16	-23.14	AVG	
3		0.5600	46.78	0.02	46.80	56.00	-9.20	QP	
4		0.5600	28.00	0.02	28.02	46.00	-17.98	AVG	
5		0.8600	45.75	0.01	45.76	56.00	-10.24	QP	
6		0.8600	23.00	0.01	23.01	46.00	-22.99	AVG	
7		2.6600	46.00	0.05	46.05	56.00	-9.95	QP	
8		2.6600	22.00	0.05	22.05	46.00	-23.95	AVG	
9		16.4000	35.96	0.37	36.33	60.00	-23.67	QP	

This document is issued by the Company subject to its General Conditions of Service printed overleaf or available on request and accessible at www.sgs.com. Attention is drawn to the limitations of liability, indemnification, and Jurisdictional issued defined therein. Unless otherwise stated, the results shown in this test report refer only to the sample(s) tested. This document cannot be reproduced except in full, without prior approval of Company. Any unauthorized alteration, forgery or falsification of the content or appearance of this report is unlawful and offenders may be prosecuted to the fullest extent of the law. 此報告是遵循本公司訂定之通用服務條款所製作發放。請注意此條款列印於背面，亦可在www.sgs.com中查閱。將本公司之義務，免責，管轄權皆明確規範之。除非另有說明，此報告結果僅對檢驗之樣品負責。本報告未經本公司書面許可，不可部份複製。對本報告內容或外觀之任何未經授權之變更、偽造、竄改皆屬非法，違犯者將會被依法追訴。

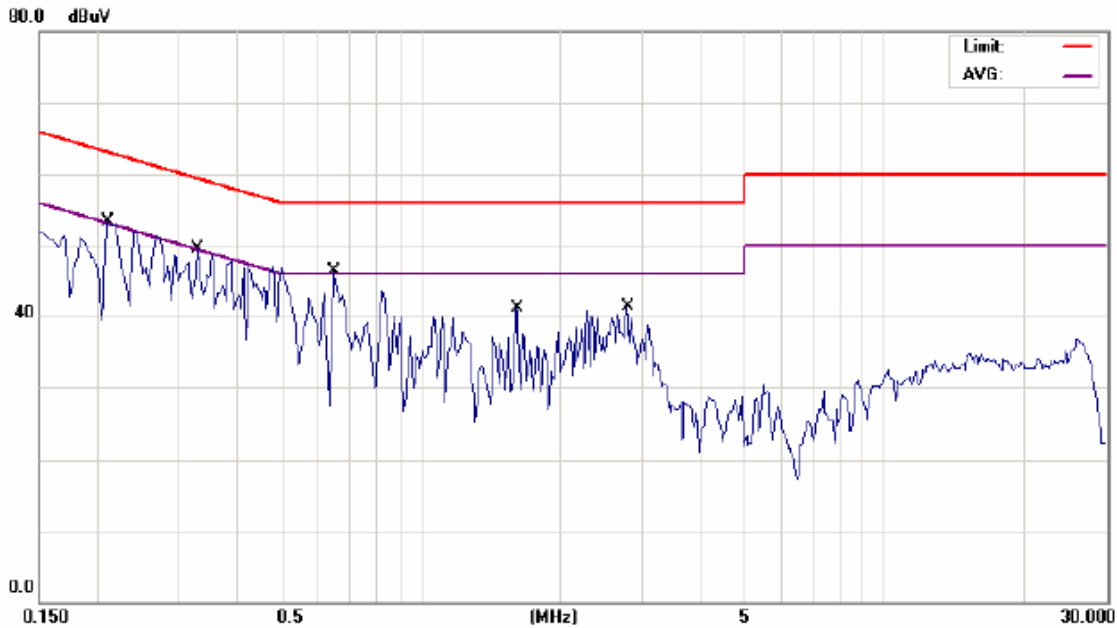

Site SGS CONDUCTED #1
 Limit: CISPR22 Class B Conduction(QP)
 EUT: Mobile
 M/N: kais 140 2nd pa
 Note: GSM 1900 Link / charger mode (DELTA)

Phase: **N**
 Power: AC 120V/60Hz
 Distance:

Temperature: 24 °C
 Humidity: 62 %
 Air Pressure: hpa

No.	Mk.	Freq. MHz	Reading Level dBuV	Factor dB	Measure- ment dBuV	Limit dBuV	Over dB	Detector	Comment
1		0.2100	53.21	0.02	53.23	63.21	-9.98	QP	
2		0.2100	35.00	0.02	35.02	53.21	-18.19	AVG	
3		0.3300	49.51	0.02	49.53	59.45	-9.92	QP	
4		0.3300	24.00	0.02	24.02	49.45	-25.43	AVG	
5	*	0.6500	46.20	0.02	46.22	56.00	-9.78	QP	
6		0.6500	18.00	0.02	18.02	46.00	-27.98	AVG	
7		1.6100	41.04	0.03	41.07	56.00	-14.93	QP	
8		2.7800	41.27	0.05	41.32	56.00	-14.68	QP	

This document is issued by the Company subject to its General Conditions of Service printed overleaf or available on request and accessible at www.sgs.com. Attention is drawn to the limitations of liability, indemnification, and Jurisdictional issued defined therein. Unless otherwise stated, the results shown in this test report refer only to the sample(s) tested. This document cannot be reproduced except in full, without prior approval of Company. Any unauthorized alteration, forgery or falsification of the content or appearance of this report is unlawful and offenders may be prosecuted to the fullest extent of the law. 此報告是遵循本公司訂定之通用服務條款所製作發放，請注意此條款列印於背面，亦可在www.sgs.com中查閱。將本公司之義務，免責，管轄權皆明確規範之。除非另有說明，此報告結果僅對檢驗之樣品負責。本報告未經本公司書面許可，不可部份複製。對本報告內容或外觀之任何未經授權之變更、偽造、竄改皆屬非法，違犯者將會被依法追訴。

AC POWER LINE CONDUCTED EMISSION TEST DATA

Operation Mode:	GSM 1900 Link + AC Adapter (PHIHONG)		Test Date:	Feb. 14, 2008	
Temperature:	25 °C	Humidity:	59 %	Test By:	Bondi

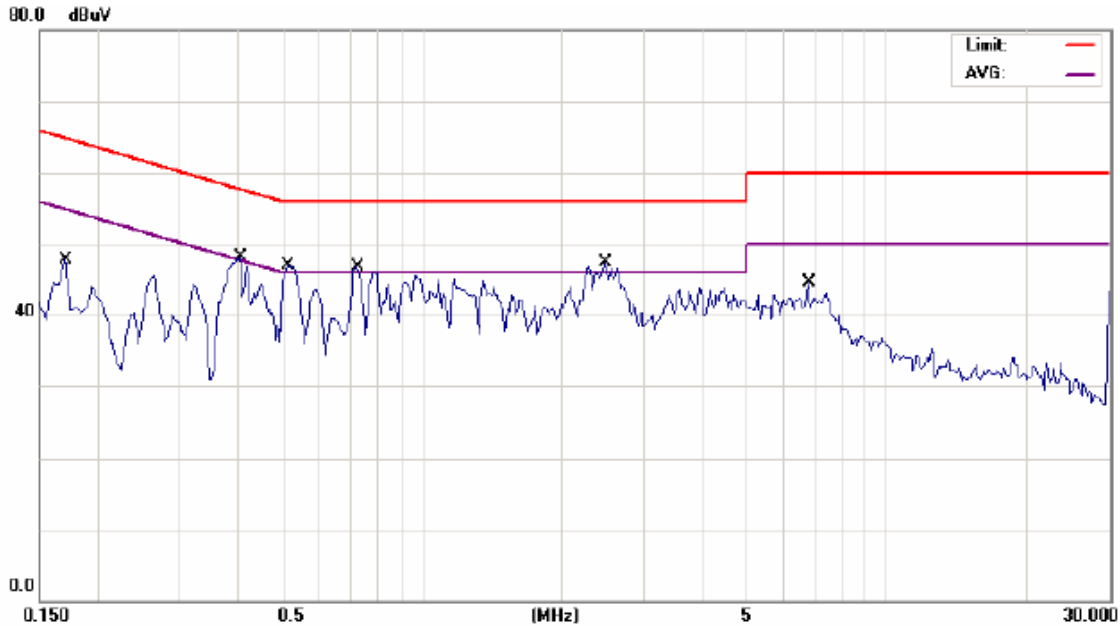

Site: SGS CONDUCTED #1
 Limit: CISPR22 Class B Conduction(QP)
 EUT: Mobile
 M/N: kais 140 2nd pa
 Note: GSM 1900 Link / charger mode (PHIHONG)

Phase: L1
 Power: AC 120V/60Hz
 Distance:
 Temperature: 24 °C
 Humidity: 62 %
 Air Pressure: hpa

No.	Mk.	Freq. MHz	Reading Level dBuV	Factor dB	Measure- ment dBuV	Limit dBuV	Over dB	Detector	Comment
1		0.1700	47.14	0.48	47.62	64.96	-17.34	QP	
2		0.4050	47.39	0.62	48.01	57.75	-9.74	QP	
3		0.4050	35.00	0.62	35.62	47.75	-12.13	AVG	
4		0.5150	46.19	0.66	46.85	56.00	-9.15	QP	
5		0.5150	32.00	0.66	32.66	46.00	-13.34	AVG	
6		0.7250	45.94	0.72	46.66	56.00	-9.34	QP	
7		0.7250	32.00	0.72	32.72	46.00	-13.28	AVG	
8	*	2.4800	46.49	0.87	47.36	56.00	-8.64	QP	
9		2.4800	28.00	0.87	28.87	46.00	-17.13	AVG	
10		6.7800	43.40	1.05	44.45	60.00	-15.55	QP	

This document is issued by the Company subject to its General Conditions of Service printed overleaf or available on request and accessible at www.sgs.com. Attention is drawn to the limitations of liability, indemnification, and Jurisdictional issued defined therein. Unless otherwise stated, the results shown in this test report refer only to the sample(s) tested. This document cannot be reproduced except in full, without prior approval of Company. Any unauthorized alteration, forgery or falsification of the content or appearance of this report is unlawful and offenders may be prosecuted to the fullest extent of the law. 此報告是遵循本公司訂定之通用服務條款所製作發放，請注意此條款列印於背面，亦可在www.sgs.com中查閱。將本公司之義務，免責，管轄權皆明確規範之。除非另有說明，此報告結果僅對檢驗之樣品負責。本報告未經本公司書面許可，不可部份複製。對本報告內容或外觀之任何未經授權之變更、偽造、竄改皆屬非法，違犯者將會被依法追訴。

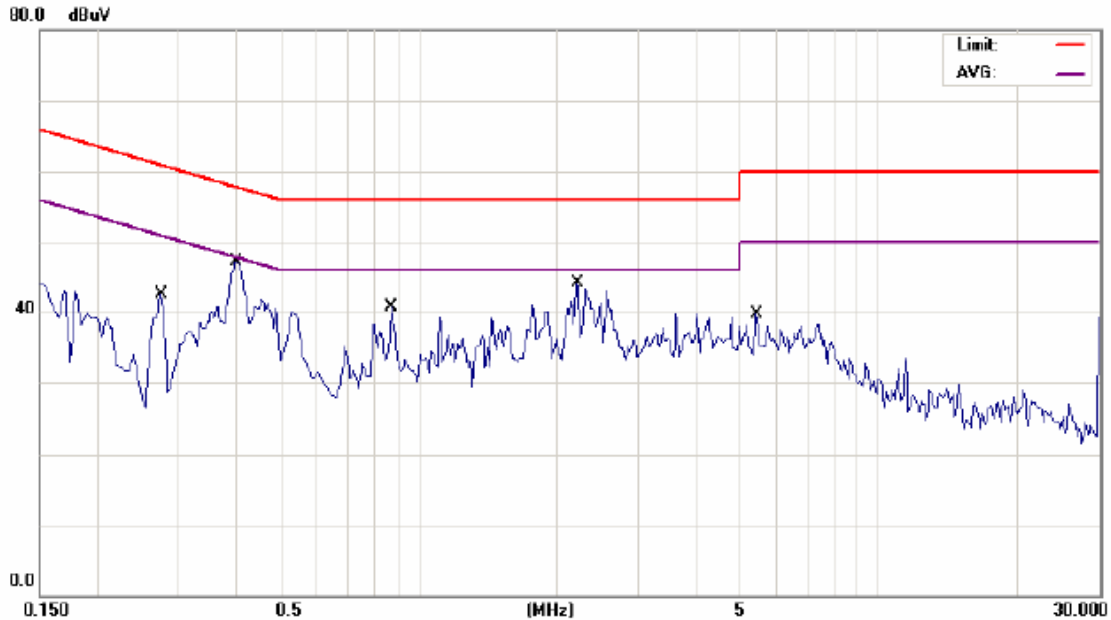

Site SGS CONDUCTED #1
 Limit: CISPR22 Class B Conduction(QP)
 EUT: Mobile
 M/N: kais 140 2nd pa
 Note: GSM 1900 Link / charger mode (PHIHONG)

Phase: **N**
 Power: AC 120V/60Hz
 Distance:

Temperature: 24 °C
 Humidity: 62 %
 Air Pressure: hpa

No.	Mk.	Freq. MHz	Reading Level dBuV	Factor dB	Measure- ment dBuV	Limit dBuV	Over dB	Detector	Comment
1		0.2750	42.39	0.02	42.41	60.97	-18.56	QP	
2	*	0.4000	47.03	0.02	47.05	57.85	-10.80	QP	
3		0.8750	40.63	0.01	40.64	56.00	-15.36	QP	
4		2.2100	44.10	0.04	44.14	56.00	-11.86	QP	
5		5.4400	39.54	0.12	39.66	60.00	-20.34	QP	

This document is issued by the Company subject to its General Conditions of Service printed overleaf or available on request and accessible at www.sgs.com. Attention is drawn to the limitations of liability, indemnification, and Jurisdictional issued defined therein. Unless otherwise stated, the results shown in this test report refer only to the sample(s) tested. This document cannot be reproduced except in full, without prior approval of Company. Any unauthorized alteration, forgery or falsification of the content or appearance of this report is unlawful and offenders may be prosecuted to the fullest extent of the law. 此報告是遵循本公司訂定之通用服務條款所製作發放，請注意此條款列印於背面，亦可在www.sgs.com中查閱。將本公司之義務，免責，管轄權皆明確規範之。除非另有說明，此報告結果僅對檢驗之樣品負責。本報告未經本公司書面許可，不可部份複製。對本報告內容或外觀之任何未經授權之變更、偽造、竄改皆屬非法，違犯者將會被依法追訴。