

## Combined

### DASY4 Configuration for WLAN/WLAN b mode ch 1-Tilt-V/Volume Scan:

Date/Time: 6/16/2006 2:14:11 PM

Test Laboratory: Compliance Certification Services

File Name: [Head-Left Hand Side.da4](#)

**DUT: HTC Smart Phone; Type: Smart phone; Serial: HT619FJ00049**

Communication System: 802.11b; Frequency: 2412 MHz; Duty Cycle: 1:1

Medium: H2450 Medium parameters used (interpolated):  $f = 2412$  MHz;  $\sigma = 1.81$  mho/m;  $\epsilon_r = 40.2$ ;  $\rho = 1000$  kg/m<sup>3</sup>

Phantom section: Left Section

Measurement Standard: DASY4 (High Precision Assessment)

- Probe: EX3DV4 - SN3552; ConvF(7.4, 7.4, 7.4); Calibrated: 5/30/2006
  - Sensor-Surface: 4mm (Mechanical Surface Detection)
  - Electronics: DAE4 SN558; Calibrated: 1/20/2006
  - Phantom: SAM 2; Type: SAM 2; Serial: 1050
  - Measurement SW: DASY4, V4.7 Build 21
- 

### DASY4 Configuration for GSM1900/GSM1900 ch 810-Tilt-V/Volume Scan:

Date/Time: 6/14/2006 1:06:06 PM

Test Laboratory: Compliance Certification Services

File Name: [Head-Left Hand Side.da4](#)

**DUT: HTC Smart Phone; Type: Smart phone; Serial: HT619FJ00049**

Communication System: DCS 1900; Frequency: 1909.8 MHz; Duty Cycle: 1:8

Medium: H1900MHz Medium parameters used:  $f = 1910$  MHz;  $\sigma = 1.43$  mho/m;  $\epsilon_r = 39.6$ ;  $\rho = 1000$  kg/m<sup>3</sup>

Phantom section: Left Section

Measurement Standard: DASY4 (High Precision Assessment)

- Probe: EX3DV4 - SN3552; ConvF(8, 8, 8); Calibrated: 5/30/2006
  - Sensor-Surface: 4mm (Mechanical Surface Detection)
  - Electronics: DAE4 SN558; Calibrated: 1/20/2006
  - Phantom: SAM 1; Type: SAM 1; Serial: 1185
  - Measurement SW: DASY4, V4.7 Build 21
- 

### Multi Band Result:

**SAR(1 g) = 1.26 mW/g; SAR(10 g) = 0.654 mW/g**

Maximum value of SAR (measured) = 1.42 mW/g

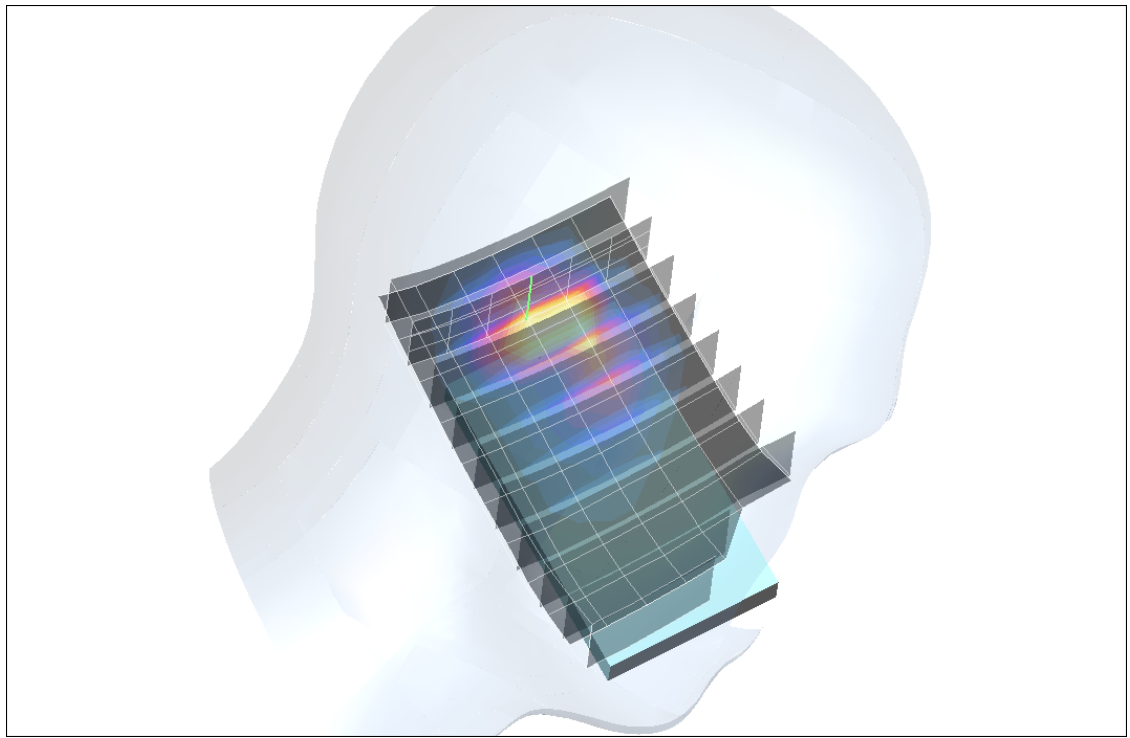
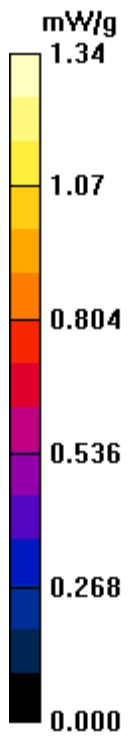

Postprocessing SW: SEMCAD, V1.8 Build 170

## Combined

### DASY4 Configuration for WLAN/WLAN b mode ch 1-Touch-V/Volume Scan:

Date/Time: 6/16/2006 2:52:07 PM

Test Laboratory: Compliance Certification Services

File Name: [Head-Right Hand Side.da4](#)

**DUT: HTC Smart Phone; Type: Smart phone; Serial: HT619FJ00049**

Communication System: 802.11b; Frequency: 2412 MHz; Duty Cycle: 1:1

Medium: H2450 MHz Medium parameters used (interpolated):  $f = 2412$  MHz;  $\sigma = 1.81$  mho/m;  $\epsilon_r = 40.2$ ;  $\rho = 1000$  kg/m<sup>3</sup>

Phantom section: Right Section

Measurement Standard: DASY4 (High Precision Assessment)

- Probe: EX3DV4 - SN3552; ConvF(7.4, 7.4, 7.4); Calibrated: 5/30/2006
  - Sensor-Surface: 4mm (Mechanical Surface Detection)
  - Electronics: DAE4 SN558; Calibrated: 1/20/2006
  - Phantom: SAM 2; Type: SAM 2; Serial: 1050
  - Measurement SW: DASY4, V4.7 Build 21
- 

### DASY4 Configuration for GSM 850/GSM850 ch 190-Touch-V/Volume Scan:

Date/Time: 6/13/2006 2:43:17 PM

Test Laboratory: Compliance Certification Services

File Name: [Head-Right Hand Side.da4](#)

**DUT: HTC Smart Phone; Type: Smart phone; Serial: HT619FJ00049**

Communication System: GSM850; Frequency: 836.6 MHz; Duty Cycle: 1:8

Medium: H835 MHz Medium parameters used (interpolated):  $f = 836.6$  MHz;  $\sigma = 0.87$  mho/m;  $\epsilon_r = 40.5$ ;  $\rho = 1000$  kg/m<sup>3</sup>

Phantom section: Right Section

Measurement Standard: DASY4 (High Precision Assessment)

- Probe: EX3DV4 - SN3552; ConvF(9.65, 9.65, 9.65); Calibrated: 5/30/2006
  - Sensor-Surface: 4mm (Mechanical Surface Detection)
  - Electronics: DAE4 SN558; Calibrated: 1/20/2006
  - Phantom: SAM 2; Type: SAM 2; Serial: 1050
  - Measurement SW: DASY4, V4.7 Build 21
- 

### Multi Band Result:

**SAR(1 g) = 1.09 mW/g; SAR(10 g) = 0.806 mW/g**

Maximum value of SAR (measured) = 1.09 mW/g

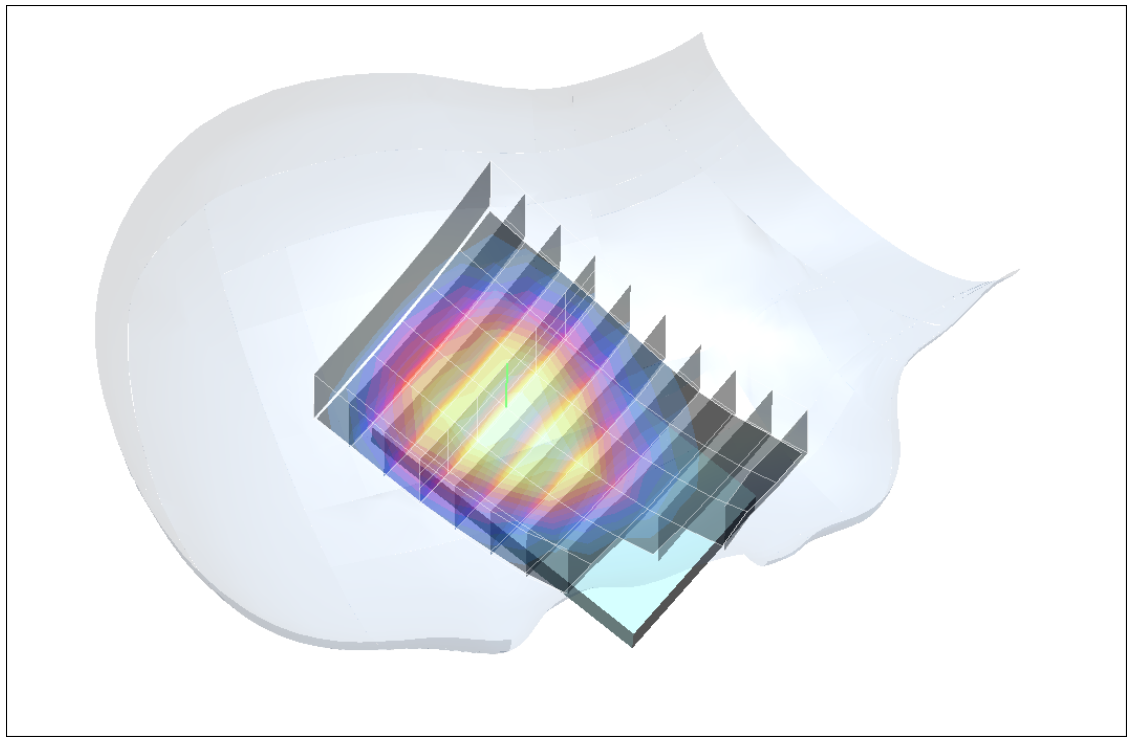
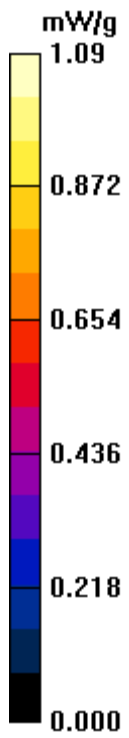

Postprocessing SW: SEMCAD, V1.8 Build 170

## Combined

### DASY4 Configuration for GSM1900/GSM850 GPRS ch 128-with Holster Face Down-V/Volume Scan:

Date/Time: 6/15/2006 6:13:01 PM

Test Laboratory: Compliance Certification Services

File Name: [Body.da4](#)

**DUT: HTC Smart Phone; Type: Smart phone; Serial: HT619FJ00049**

Communication System: GSM850; Frequency: 824.2 MHz; Duty Cycle: 1:4

Medium: M850MHz Medium parameters used:  $f = 825$  MHz;  $\sigma = 0.962$  mho/m;  $\epsilon_r = 53.9$ ;  $\rho = 1000$  kg/m<sup>3</sup>

Phantom section: Flat Section

Measurement Standard: DASY4 (High Precision Assessment)

- Probe: EX3DV4 - SN3552; ConvF(9.57, 9.57, 9.57); Calibrated: 5/30/2006
  - Sensor-Surface: 4mm (Mechanical Surface Detection)
  - Electronics: DAE4 SN558; Calibrated: 1/20/2006
  - Phantom: SAM 2; Type: SAM 2; Serial: 1050
  - Measurement SW: DASY4, V4.7 Build 21
- 

### DASY4 Configuration for WLAN/WLAN b mode ch 1-with Holster Face Up-V/Volume Scan:

Date/Time: 6/16/2006 1:08:58 PM

Test Laboratory: Compliance Certification Services

File Name: [Body.da4](#)

**DUT: HTC Smart Phone; Type: Smart phone; Serial: HT619FJ00049**

Communication System: 802.11b; Frequency: 2412 MHz; Duty Cycle: 1:1

Medium: M2450MHz Medium parameters used (interpolated):  $f = 2412$  MHz;  $\sigma = 1.99$  mho/m;  $\epsilon_r = 52.5$ ;  $\rho = 1000$  kg/m<sup>3</sup>

Phantom section: Flat Section

Measurement Standard: DASY4 (High Precision Assessment)

- Probe: EX3DV4 - SN3552; ConvF(7.08, 7.08, 7.08); Calibrated: 5/30/2006
  - Sensor-Surface: 4mm (Mechanical Surface Detection)
  - Electronics: DAE4 SN558; Calibrated: 1/20/2006
  - Phantom: SAM 1; Type: SAM 1; Serial: 1185
  - Measurement SW: DASY4, V4.7 Build 21
- 

### Multi Band Result:

**SAR(1 g) = 1.49 mW/g; SAR(10 g) = 1.02 mW/g**

Maximum value of SAR (measured) = 1.47 mW/g

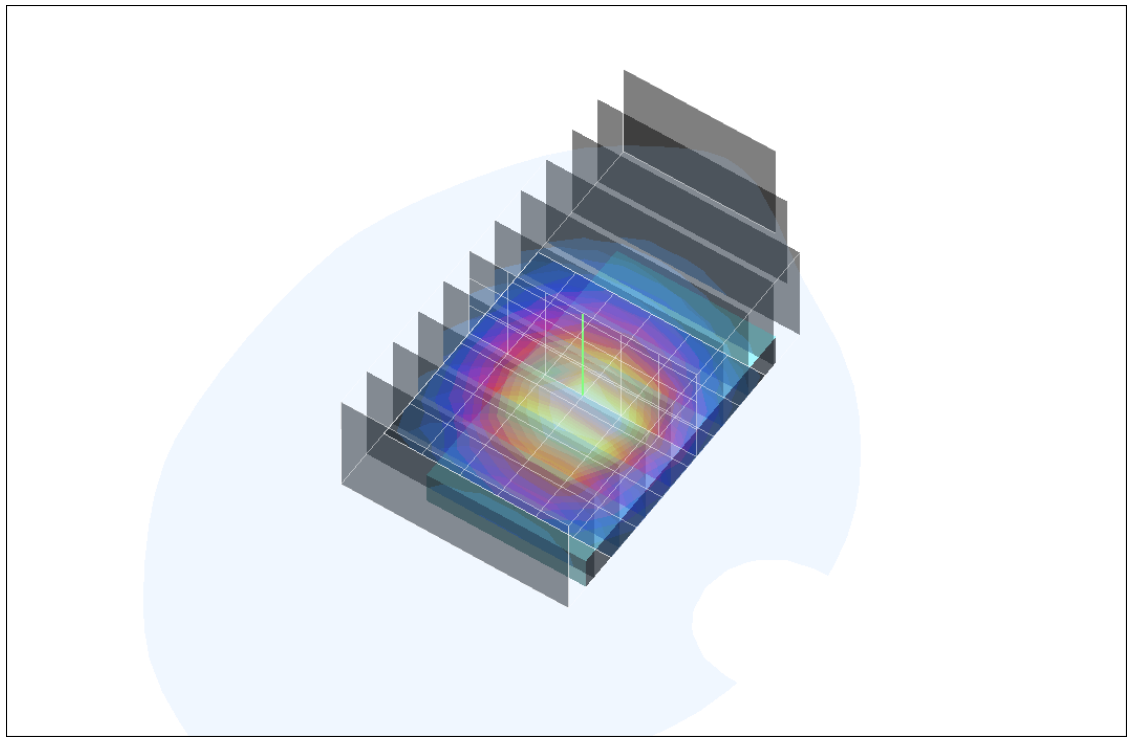
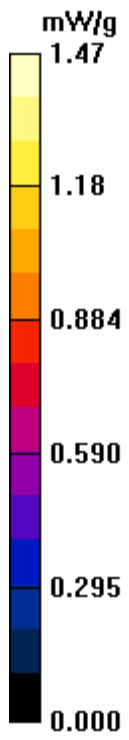

Postprocessing SW: SEMCAD, V1.8 Build 170

## Combined

### DASY4 Configuration for WLAN/WLAN b mode ch 1-with Holster Face Up-V/Volume Scan:

Date/Time: 6/16/2006 1:08:58 PM

Test Laboratory: Compliance Certification Services

File Name: [Body.da4](#)

**DUT: HTC Smart Phone; Type: Smart phone; Serial: HT619FJ00049**

Communication System: 802.11b; Frequency: 2412 MHz; Duty Cycle: 1:1

Medium: M2450MHz Medium parameters used (interpolated):  $f = 2412$  MHz;  $\sigma = 1.99$  mho/m;  $\epsilon_r = 52.5$ ;  $\rho = 1000$  kg/m<sup>3</sup>

Phantom section: Flat Section

Measurement Standard: DASY4 (High Precision Assessment)

- Probe: EX3DV4 - SN3552; ConvF(7.08, 7.08, 7.08); Calibrated: 5/30/2006
  - Sensor-Surface: 4mm (Mechanical Surface Detection)
  - Electronics: DAE4 SN558; Calibrated: 1/20/2006
  - Phantom: SAM 1; Type: SAM 1; Serial: 1185
  - Measurement SW: DASY4, V4.7 Build 21
- 

### DASY4 Configuration for GSM1900/GSM1900 GPRS ch 810-with Holster Face Down-V/Volume Scan:

Date/Time: 6/15/2006 12:53:31 PM

Test Laboratory: Compliance Certification Services

File Name: [Body.da4](#)

**DUT: HTC Smart Phone; Type: Smart phone; Serial: HT619FJ00049**

Communication System: PCS 1900; Frequency: 1909.8 MHz; Duty Cycle: 1:4

Medium: M1900MHz Medium parameters used:  $f = 1910$  MHz;  $\sigma = 1.47$  mho/m;  $\epsilon_r = 51.6$ ;  $\rho = 1000$  kg/m<sup>3</sup>

Phantom section: Flat Section

Measurement Standard: DASY4 (High Precision Assessment)

- Probe: EX3DV4 - SN3552; ConvF(7.6, 7.6, 7.6); Calibrated: 5/30/2006
  - Sensor-Surface: 4mm (Mechanical Surface Detection)
  - Electronics: DAE4 SN558; Calibrated: 1/20/2006
  - Phantom: SAM 1; Type: SAM 1; Serial: 1185
  - Measurement SW: DASY4, V4.7 Build 21
- 

### Multi Band Result:

**SAR(1 g) = 0.952 mW/g; SAR(10 g) = 0.587 mW/g**

Maximum value of SAR (measured) = 1.01 mW/g

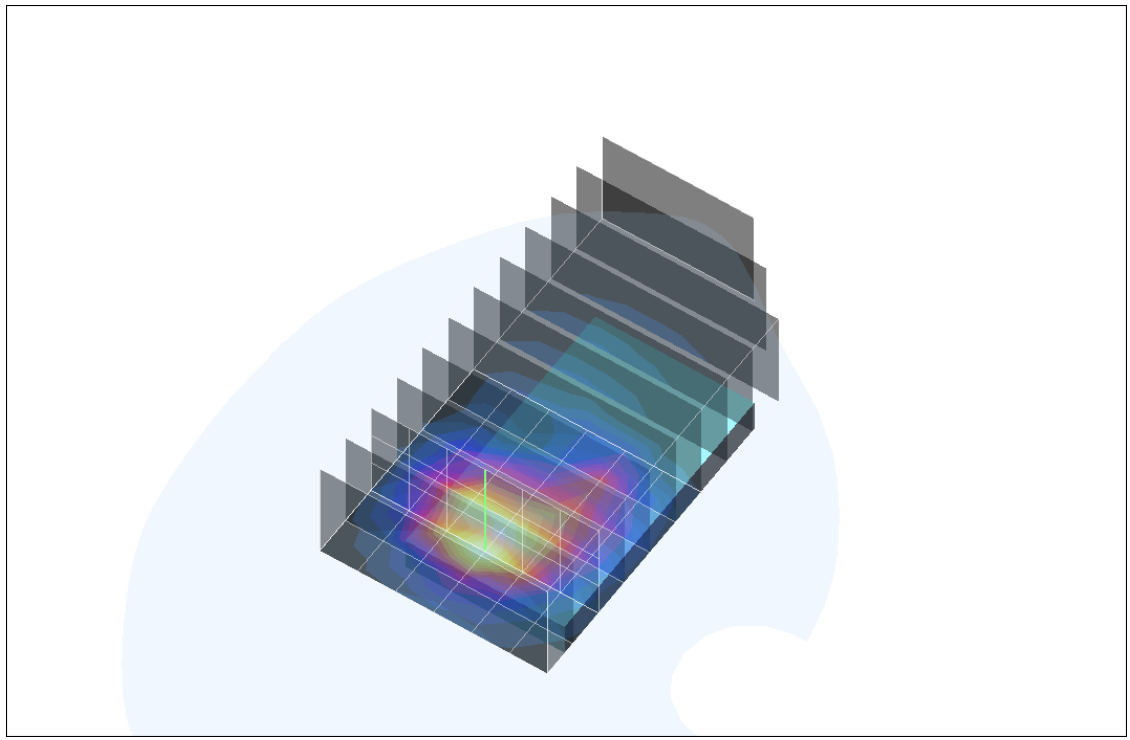
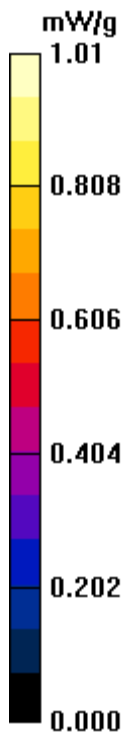

Postprocessing SW: SEMCAD, V1.8 Build 170