

FCC RF Test Report

APPLICANT : HTC Corporation
EQUIPMENT : HTC Stereo Headphones - Bluetooth In-ear
MODEL NAME : BH S600
FCC ID : NM8BHS600
STANDARD : FCC Part 15 Subpart C §15.247
CLASSIFICATION : (DSS) Spread Spectrum Transmitter

The product was received on Sep. 04, 2012 and completely tested on Sep. 21, 2012. We, SPORTON INTERNATIONAL INC., would like to declare that the tested sample has been evaluated in accordance with the procedures and shown the compliance with the applicable technical standards.

The test results in this report apply exclusively to the tested model / sample. Without written approval of SPORTON INTERNATIONAL INC., the test report shall not be reproduced except in full.

Reviewed by:



Jones Tsai / Manager



SPORTON INTERNATIONAL INC.

No. 52, Hwa Ya 1st Rd., Hwa Ya Technology Park, Kwei-Shan Hsiang, Tao Yuan Hsien, Taiwan, R.O.C.



TABLE OF CONTENTS

REVISION HISTORY 3

SUMMARY OF TEST RESULT 4

1 GENERAL DESCRIPTION..... 5

 1.1 Applicant 5

 1.2 Manufacturer..... 5

 1.3 Feature of Equipment Under Test 6

 1.4 Testing Site 7

 1.5 Applied Standards 7

 1.6 Ancillary Equipment List 7

2 TEST CONFIGURATION OF EQUIPMENT UNDER TEST..... 8

 2.1 RF Output Power 8

 2.2 Test Mode..... 9

 2.3 Connection Diagram of Test System..... 10

 2.4 RF Utility 11

3 TEST RESULT 12

 3.1 Number of Channel Measurement 12

 3.2 Hopping Channel Separation Measurement 14

 3.3 Dwell Time Measurement..... 21

 3.4 20dB and 99% Bandwidth Measurement 23

 3.5 Peak Output Power Measurement 36

 3.6 Conducted Band Edges Measurement..... 43

 3.7 Conducted Spurious Emission Measurement 46

 3.8 Radiated Band Edges and Spurious Emission Measurement 50

 3.9 AC Conducted Emission Measurement..... 60

 3.10 Antenna Requirements 64

4 LIST OF MEASURING EQUIPMENT..... 65

5 UNCERTAINTY OF EVALUATION..... 66

APPENDIX A. SETUP PHOTOGRAPHS



REVISION HISTORY

REPORT NO.	VERSION	DESCRIPTION	ISSUED DATE
FR290407	Rev. 01	Initial issue of report	Oct. 04, 2012
FR290407	Rev. 02	Update report for revising manufacturer information	Oct. 05, 2012



SUMMARY OF TEST RESULT

Report Section	FCC Rule	IC Rule	Description	Limit	Result	Remark
3.1	15.247(a)(1)	A8.4(2)	Number of Channels	≥ 15Chs	Pass	-
3.2	15.247(a)(1)	A8.1(b)	Hopping Channel Separation	≥ 2/3 of 20dB BW	Pass	-
3.3	15.247(a)(1)	A8.1(d)	Dwell Time of Each Channel	≤ 0.4sec in 31.6sec period	Pass	-
3.4	15.247(a)(1)	A8.1(a)	20dB Bandwidth	NA	Pass	-
3.4	-	Gen 4.6.1	99% Bandwidth	-	Pass	-
3.5	15.247(b)(1)	A8.1(b)	Peak Output Power	≤ 1 w for 1Mbps ≤ 125 Mw for 2, 3Mbps	Pass	-
3.6	15.247(d)	A8.5	Conducted Band Edges	≤ 20dBc	Pass	-
3.7	15.247(d)	A8.5	Conducted Spurious Emission	≤ 20dBc	Pass	-
3.8.8	15.247(d)	A8.5	Radiated Band Edges and Radiated Spurious Emission	15.209(a) & 15.247(d)	Pass	Under limit 12.98 dB at 209.820 MHz
3.9	15.207	Gen 7.2.4	AC Conducted Emission	15.207(a)	Pass	Under limit 15.10 dB at 0.198 MHz
3.10	15.203 & 15.247(b)	A8.4	Antenna Requirement	N/A	Pass	-



1 General Description

1.1 Applicant

HTC Corporation

No. 23 Xinghua Rd., Taoyuan City, Taiwan

1.2 Manufacturer

MERRY ELECTRONICS (SHENZHEN) CO., LTD.

Merry Ind. Park Hua Rong Rd., DaLang, BaoAn ShenZhen 518109 China

1.3 Feature of Equipment Under Test

Product Feature	
Equipment	HTC Stereo Headphones - Bluetooth In-ear
Model Name	BH S600
FCC ID	NM8BHS600
Sample 1	EUT with black color
Sample 2	EUT with white color
EUT supports Radios application	Bluetooth
HW Version	BHC617-R2-M-0823-1
SW Version	Ver.3.0.0-20120903_2
EUT Stage	Production Unit

Remark: The above EUT's information was declared by manufacturer. Please refer to the specifications or user's manual for more detailed description.

Product Specification subjective to this standard	
Tx/Rx Frequency Range	2402 MHz ~ 2480 MHz
Number of Channels	79
Carrier Frequency of Each Channel	2402+n*1 MHz; n=0~78
Maximum Output Power to Antenna	Bluetooth (1Mbps) : 3.40 dBm (0.0022 W) Bluetooth EDR (2Mbps) : 4.34 dBm (0.0027 W) Bluetooth EDR (3Mbps) : 4.69 dBm (0.0029 W)
99% Occupied Bandwidth	Bluetooth (1Mbps) : 0.875MHz Bluetooth EDR (2Mbps) : 1.163MHz Bluetooth EDR (3Mbps) : 1.173MHz
Antenna Type	Chip Antenna type with gain 2.50 dBi
Type of Modulation	Bluetooth (1Mbps) : GFSK Bluetooth 2.1 EDR (2Mbps) : $\pi/4$ -DQPSK Bluetooth 2.1 EDR (3Mbps) : 8-DPSK Bluetooth 3.0 EDR : GFSK, $\pi/4$ -DQPSK, 8-DPSK

Specification of Accessory		
HTC Stereo Headphones - Bluetooth In-ear	Black, Global	P/N: 39H00009-00M
	White, Global	P/N: 39H00009-02M
Headset	Black, Global	P/N: 39H00011-00M
	White, Global	P/N: 39H00011-02M

1.4 Testing Site

Test Site	SPORTON INTERNATIONAL INC.			
Test Site Location	No. 52, Hwa Ya 1 st Rd., Hwa Ya Technology Park, Kwei-Shan Hsiang, Tao Yuan Hsien, Taiwan, R.O.C. TEL: +886-3-3273456 / FAX: +886-3-3284978			
Test Site No.	Sporton Site No.			FCC/IC Registration No.
	TH02-HY	CO05-HY	03CH06-HY	722060/4086B-1

1.5 Applied Standards

According to the specifications of the manufacturer, the EUT must comply with the requirements of the following standards:

- ♦ FCC Part 15 Subpart C §15.247
- ♦ FCC Public Notice DA 00-705
- ♦ ANSI C63.4-2003 and ANSI C63.10-2009
- ♦ IC RSS-210 Issue 8
- ♦ IC RSS-Gen Issue 3

Remark:

1. All test items were verified and recorded according to the standards and without any deviation during the test.
2. This EUT has also been tested and complied with the requirements of FCC Part 15, Subpart B, recorded in a separate test report.

1.6 Ancillary Equipment List

Item	Equipment	Trade Name	Model Name	FCC ID	Data Cable	Power Cord
1.	Bluetooth Base Station	R&S	CBT32	N/A	N/A	Unshielded, 1.8 m
2.	Notebook	DELL	Latitude E6320	FCC DoC	N/A	AC I/P: Unshielded, 1.2 m DC O/P: Shielded, 1.8 m
3.	LCD Monitor	Lenovo	6135-AB1	FCC DoC	Shielded, 1.6 m	Unshielded, 1.8 m
4.	Smart Phone	hTC	PL01100	NMPL01100	N/A	Unshielded, 1.2 m
5.	iPod	Apple	A1285	FCC DoC	Shielded, 1.0 m	N/A

2 Test Configuration of Equipment Under Test

2.1 RF Output Power

Preliminary tests were performed in different data rate and recorded the RF output power in the following table:

Channel	Frequency	Bluetooth RF Output Power		
		Data Rate / Modulation		
		GFSK	$\pi/4$ -DQPSK	8-DPSK
		1Mbps	2Mbps	3Mbps
Ch00	2402MHz	2.33 dBm	3.04 dBm	3.39 dBm
Ch39	2441MHz	3.40 dBm	4.34 dBm	4.69 dBm
Ch78	2480MHz	3.25 dBm	4.12 dBm	4.48 dBm

Remark:

1. All the test data for each data rate were verified, but only the worst case was reported.
2. The data rate was set in 3Mbps for all the test items due to the highest RF output power.
3. The EUT is programmed to transmit signals continuously for all testing.

2.2 Test Mode

The EUT has been associated with peripherals pursuant to ANSI C63.4-2003 and ANSI C63.10-2009 and configuration operated in a manner tended to maximize its emission characteristics in a typical application. Frequency range investigated: conduction (150 KHz to 30 MHz), radiation (9 KHz to the 10th harmonic of the highest fundamental frequency or to 40 GHz, whichever is lower).

Test Cases			
Test Item	Data Rate / Modulation		
	Bluetooth 1Mbps GFSK	Bluetooth EDR 2Mbps $\pi/4$ -DQPSK	Bluetooth EDR 3Mbps 8-DPSK
Conducted TCs	Mode 1: CH00_2402 MHz Mode 2: CH39_2441 MHz Mode 3: CH78_2480 MHz	Mode 4: CH00_2402 MHz Mode 5: CH39_2441 MHz Mode 6: CH78_2480 MHz	Mode 7: CH00_2402 MHz Mode 8: CH39_2441 MHz Mode 9: CH78_2480 MHz
Radiated TCs	Pretest	Pretest	Mode 1: CH00_2402 MHz + Earphone 1 Mode 2: CH39_2441 MHz + Earphone 1 Mode 3: CH78_2480 MHz + Earphone 1
AC Conducted Emission	Mode 1 :Bluetooth Link + USB Cable (Charging from Notebook) + Earphone 1 + MP3 <Fig. 1> Mode 2 :Bluetooth Link + USB Cable (Charging from Notebook) + Earphone 1 + Voice call <Fig. 2>		
Remark: <ol style="list-style-type: none"> For radiated TCs, the data rate was set in 3Mbps due to the highest RF output power; only the data of these modes was reported. For conducted emission, the worst case is mode 1; only the test data of this mode was reported. All the tests were performed with Sample 1. 			

2.3 Connection Diagram of Test System

<Bluetooth Tx Mode>

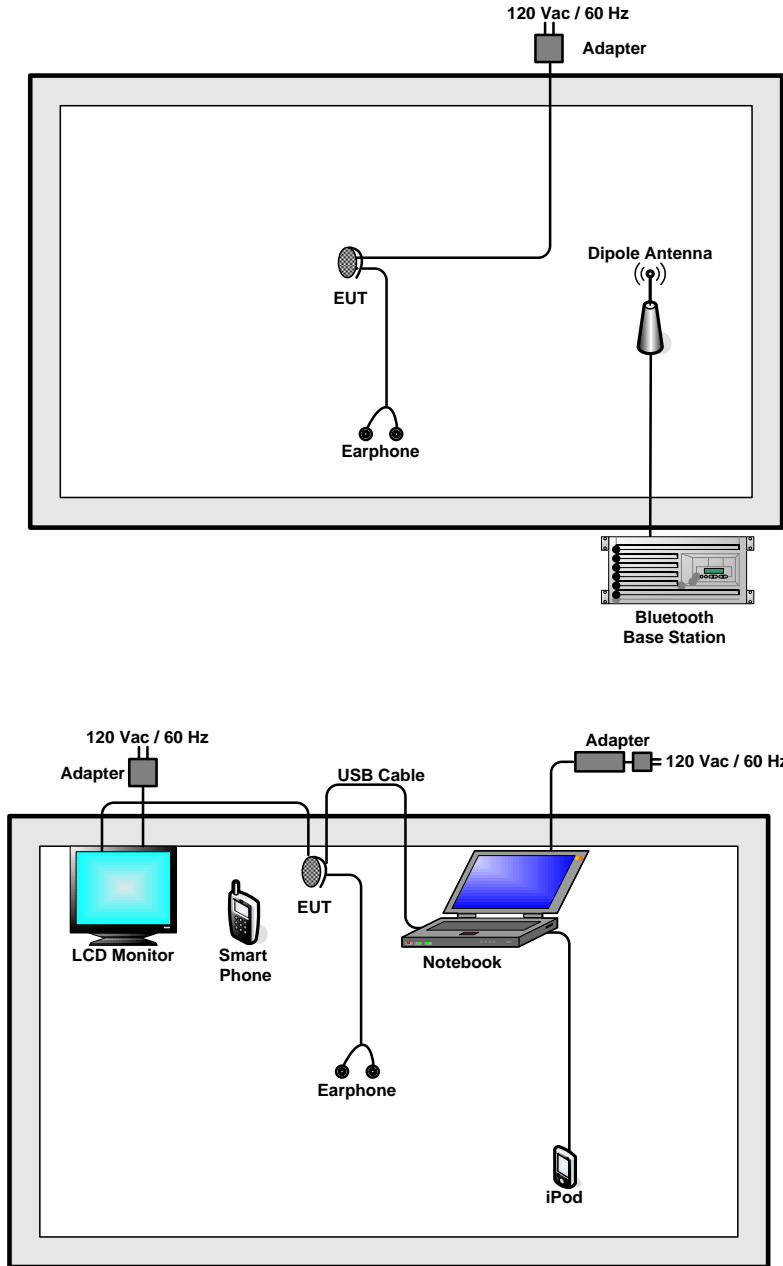

<Fig. 1>

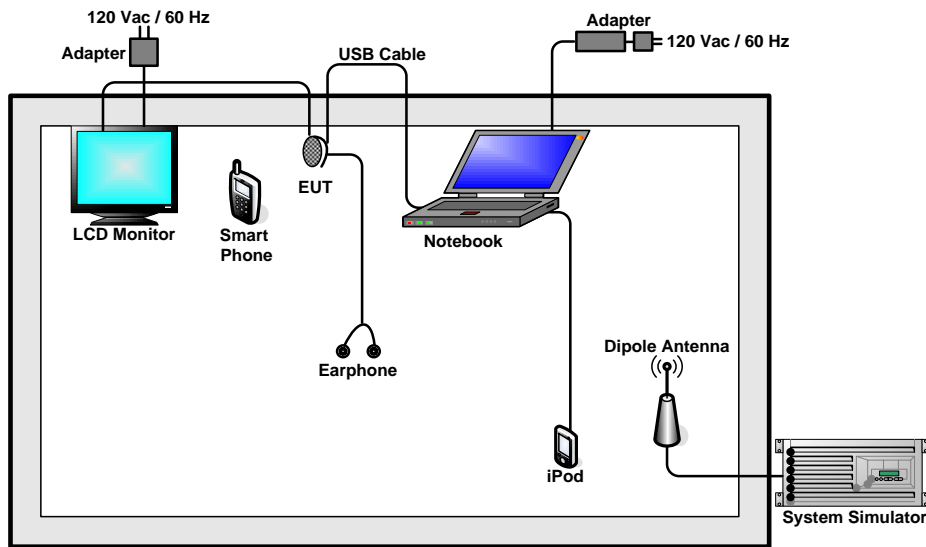

<Fig. 2>

2.4 RF Utility

Turn on the power and pressed the music play button and volume control button for 5 seconds continually, the EUT contact with Bluetooth base station for continuous transmitting and receiving signals.

3 Test Result

3.1 Number of Channel Measurement

3.1.1 Limits of Number of Hopping Frequency

Frequency hopping systems in the 2400-2483.5 MHz band shall use at least 15 channels.

3.1.2 Measuring Instruments

See list of measuring instruments of this test report.

3.1.3 Test Procedure

1. The testing follows FCC Public Notice DA 00-705 Measurement Guidelines.
2. The RF output of EUT was connected to the spectrum analyzer by a low loss cable.
3. Set to the maximum power setting and enable the EUT transmit continuously.
4. Enable the EUT hopping function.
5. Use the following spectrum analyzer settings: Span = the frequency band of operation; RBW \geq 1% of the span; VBW \geq RBW; Sweep = auto; Detector function = peak; Trace = max hold.
6. The number of hopping frequency used is defined as the number of total channel.

3.1.4 Test Setup

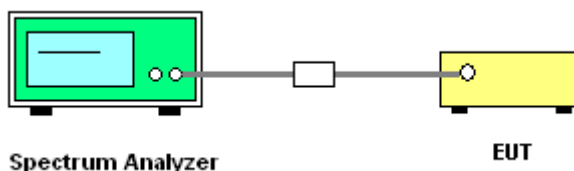

3.1.5 Test Result of Number of Hopping Frequency

Test Mode :	3Mbps	Temperature :	24~26°C
Test Engineer :	Coyote Lin	Relative Humidity :	50~53%
Number of Hopping Channels (Channel)		Limits (Channel)	Pass/Fail
79		> 15	Pass



Number of Hopping Channel Plot on Channel 00 - 78

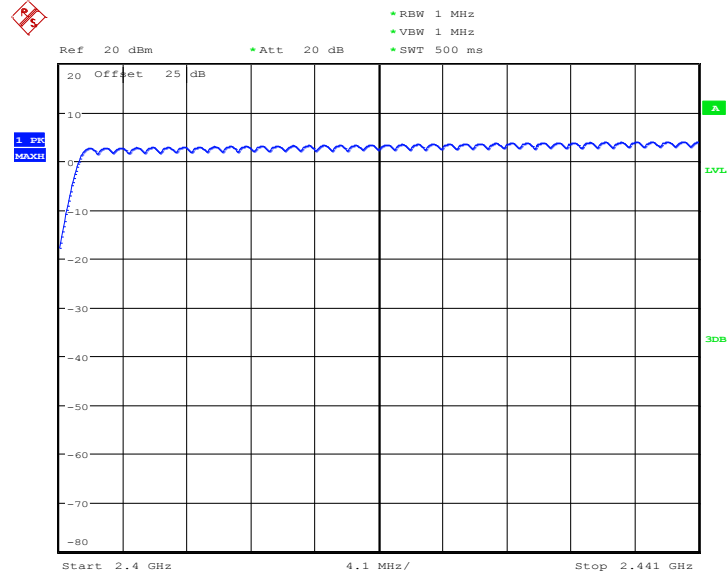

Date: 21.SEP.2012 12:23:07

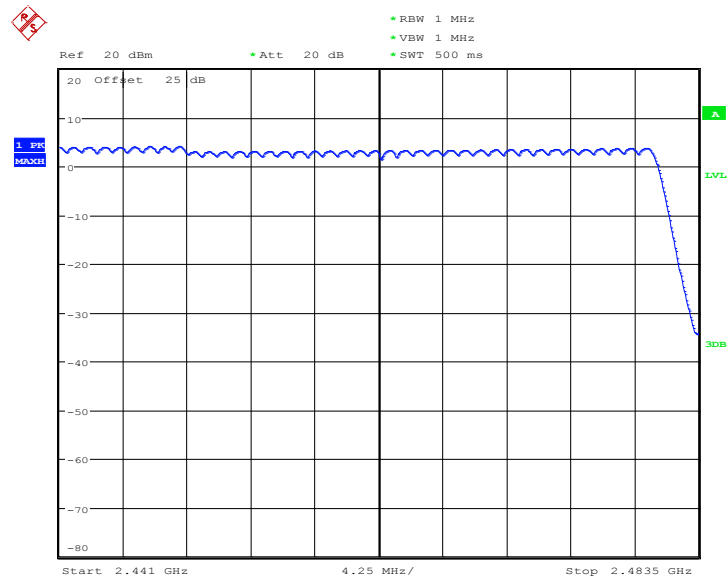

Date: 21.SEP.2012 12:28:01

3.2 Hopping Channel Separation Measurement

3.2.1 Limit of Hopping Channel Separation

Frequency hopping systems operating in the 2400-2483.5 MHz band may have hopping channel carrier frequencies that are separated by 25 KHz or two-thirds of the 20 dB bandwidth of the hopping channel, whichever is greater.

3.2.2 Measuring Instruments

See list of measuring instruments of this test report.

3.2.3 Test Procedures

1. The testing follows FCC Public Notice DA 00-705 Measurement Guidelines.
2. The RF output of EUT was connected to the spectrum analyzer by a low loss cable.
3. Set to the maximum power setting and enable the EUT transmit continuously.
4. Enable the EUT hopping function.
5. Use the following spectrum analyzer settings:
Span = wide enough to capture the peaks of two adjacent channels; $RBW \geq 1\%$ of the span;
VBW \geq RBW; Sweep = auto; Detector function = peak; Trace = max hold.

3.2.4 Test Setup

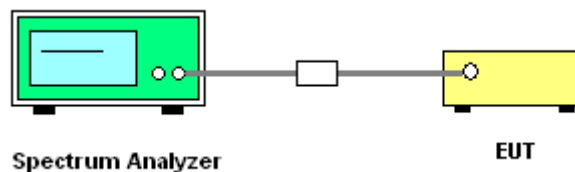



3.2.5 Test Result of Hopping Channel Separation

Test Mode :	1Mbps	Temperature :	24~26°C
Test Engineer :	Coyote Lin	Relative Humidity :	50~53%

Channel	Frequency (MHz)	Frequency Separation (MHz)	(2/3 of 20dB BW) Limits (MHz)	Pass/Fail
00	2402	1.000	0.6346	Pass
39	2441	1.000	0.6090	Pass
78	2480	1.000	0.6090	Pass

Channel Separation Plot on Channel 00 - 01

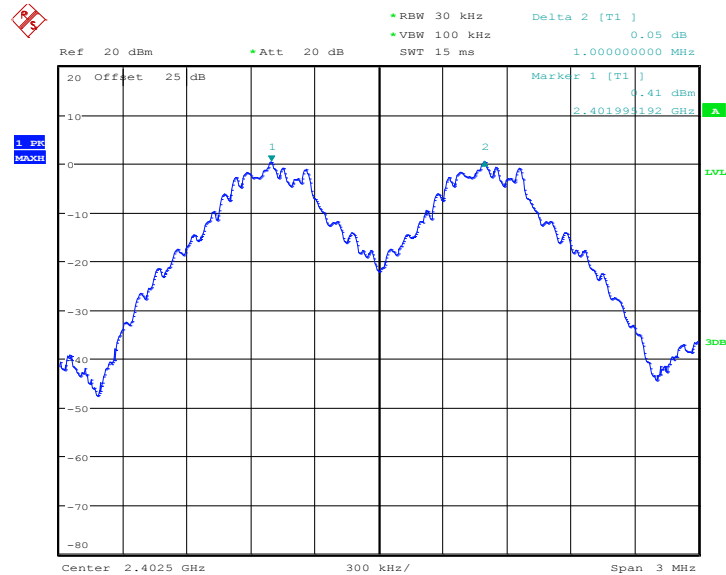

Date: 21.SEP.2012 14:11:34



Channel Separation Plot on Channel 39 - 40

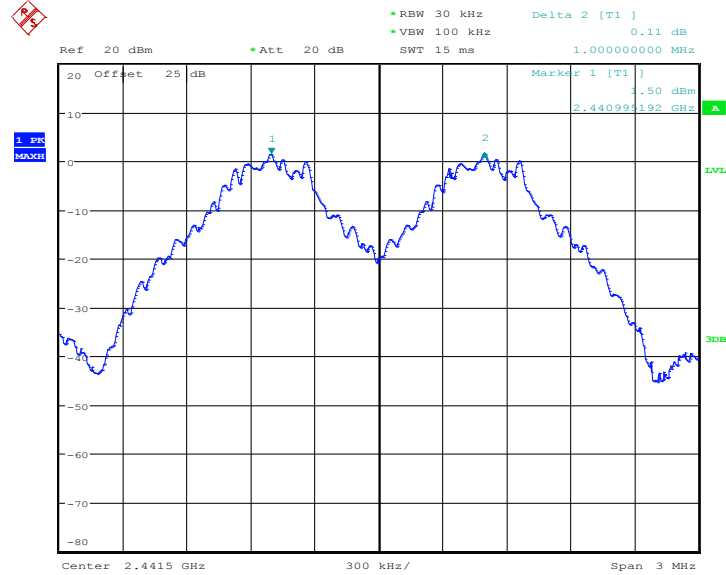

Date: 21.SEP.2012 14:12:56

Channel Separation Plot on Channel 77 - 78

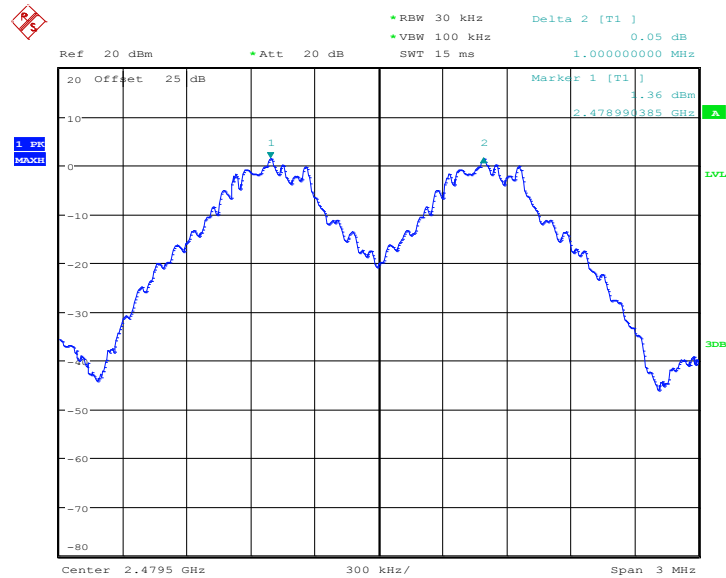

Date: 21.SEP.2012 14:14:45



Test Mode :	2Mbps	Temperature :	24~26°C
Test Engineer :	Coyote Lin	Relative Humidity :	50~53%

Channel	Frequency (MHz)	Frequency Separation (MHz)	(2/3 of 20dB BW) Limits (MHz)	Pass/Fail
00	2402	1.000	0.8429	Pass
39	2441	1.000	0.8429	Pass
78	2480	1.000	0.8429	Pass

Channel Separation Plot on Channel 00 - 01

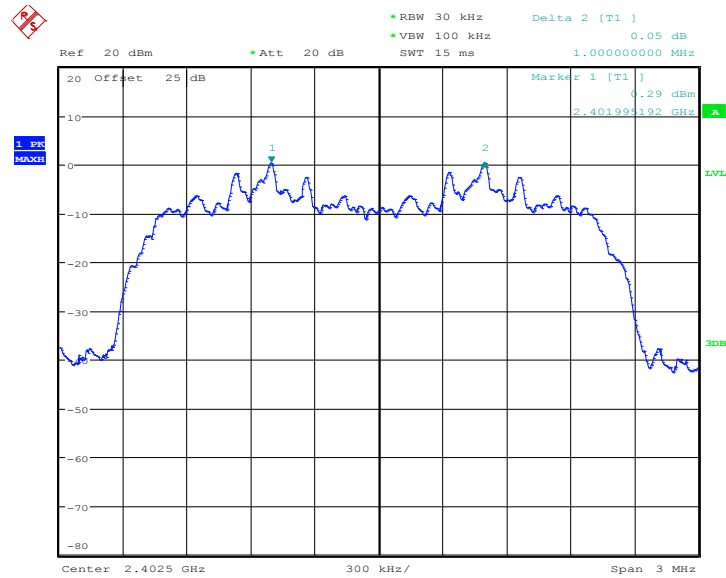

Date: 21.SEP.2012 14:16:42



Channel Separation Plot on Channel 39 - 40

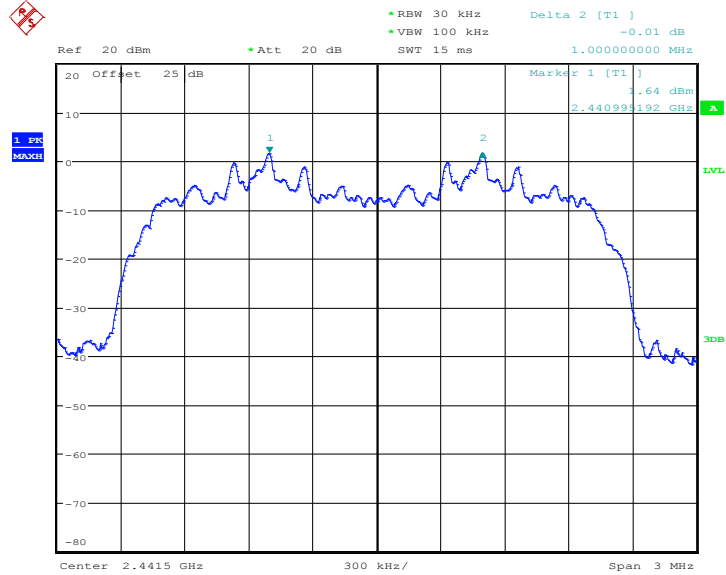

Date: 21.SEP.2012 14:18:20

Channel Separation Plot on Channel 77 - 78

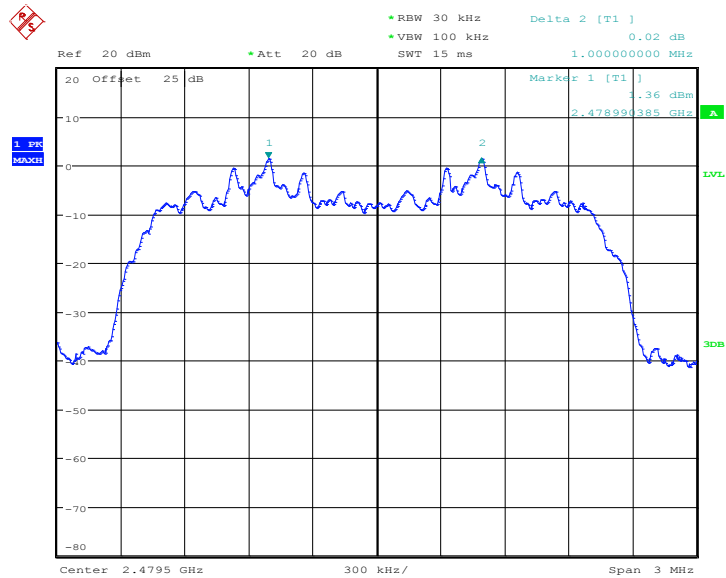

Date: 21.SEP.2012 14:20:22



Test Mode :	3Mbps	Temperature :	24~26°C
Test Engineer :	Coyote Lin	Relative Humidity :	50~53%

Channel	Frequency (MHz)	Frequency Separation (MHz)	(2/3 of 20dB BW) Limits (MHz)	Pass/Fail
00	2402	1.000	0.8525	Pass
39	2441	1.000	0.8525	Pass
78	2480	1.000	0.8525	Pass

Channel Separation Plot on Channel 00 - 01

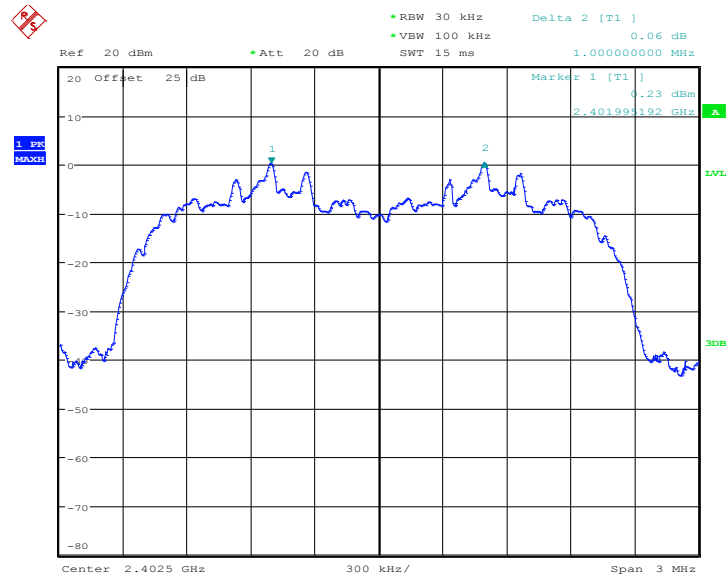

Date: 21.SEP.2012 14:22:17



Channel Separation Plot on Channel 39 - 40

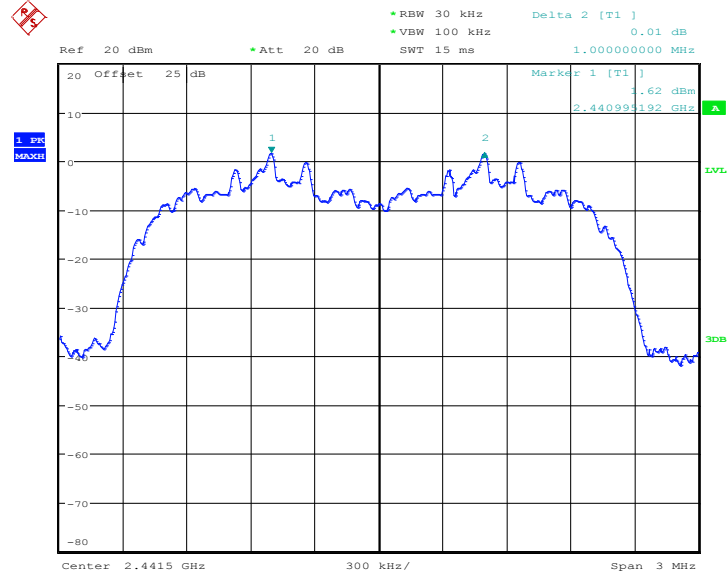

Date: 21.SEP.2012 14:23:33

Channel Separation Plot on Channel 77 - 78

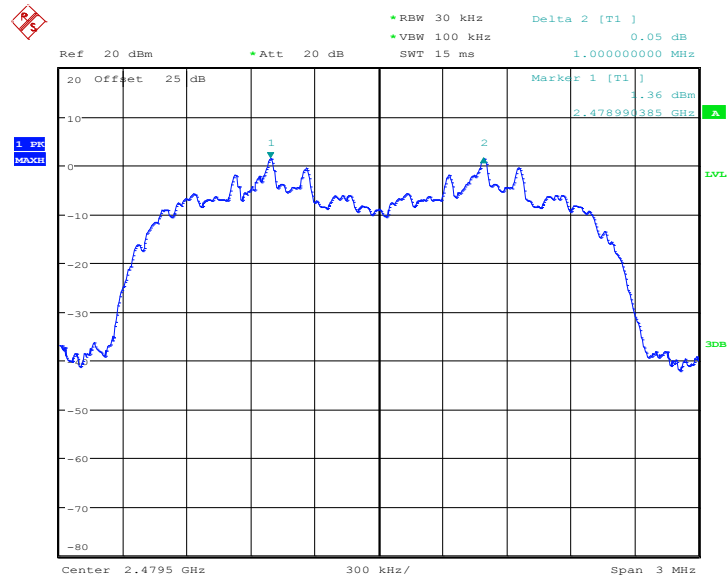

Date: 21.SEP.2012 14:25:11

3.3 Dwell Time Measurement

3.3.1 Limit of Dwell Time

The average time of occupancy on any channel shall not be greater than 0.4 seconds within a period of 0.4 seconds multiplied by the number of hopping channels employed.

3.3.2 Measuring Instruments

See list of measuring instruments of this test report.

3.3.3 Test Procedures

1. The testing follows FCC Public Notice DA 00-705 Measurement Guidelines.
2. The RF output connector was connected to the spectrum analyzer through a low loss cable.
3. Set to the maximum power setting and enable the EUT transmit continuously.
4. Enable the EUT hopping function.
5. Use the following spectrum analyzer settings: Span = zero span, centered on a hopping channel; RBW = 1 MHz; VBW ≥ RBW; Sweep = as necessary to capture the entire dwell time per hopping channel; Detector function = peak; Trace = max hold.

3.3.4 Test Setup

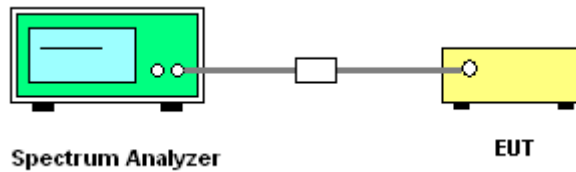

3.3.5 Test Result of Dwell Time

Test Mode :	3DH5	Temperature :	24~26°C
Test Engineer :	Coyote Lin	Relative Humidity :	50~53%

Package Mode	Average Hopping Channel	Package Transfer Time (usec)	Dwell Time (sec)	Limits (sec)	Pass/Fail
3DH5	3.00	2982.69	0.28	0.4	Pass

Remark:

1. Dwell Time=79(channels) x 0.4(s) x average hopping channel x package transfer time
2. 79 channels come from the Hopping Channel number.
3. Average Hopping Channel = hops/sweep time
4. T: Package Transfer Time(us)



3DH5 Dwell Time (One Pulse) Plot on Channel 39

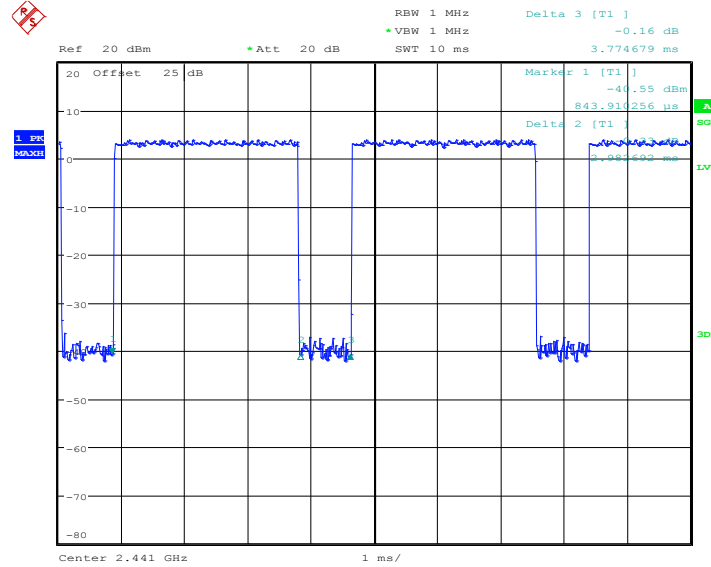

Date: 21.SEP.2012 14:37:05

3DH5 Dwell Time (Count Pulses) Plot on Channel 39

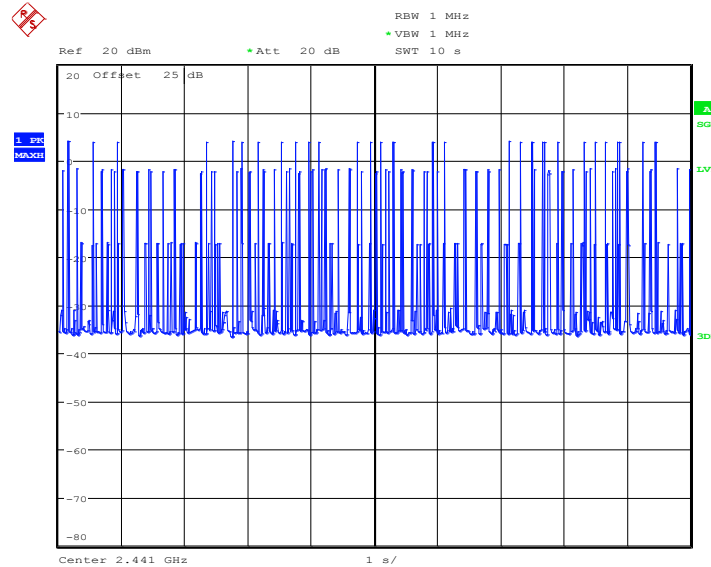

Date: 21.SEP.2012 12:04:58

3.4 20dB and 99% Bandwidth Measurement

3.4.1 Limit of 20dB Bandwidth

Reporting only

3.4.2 Measuring Instruments

See list of measuring instruments of this test report.

3.4.3 Test Procedures

1. The testing follows FCC Public Notice DA 00-705 Measurement Guidelines.
2. The RF output of EUT was connected to the spectrum analyzer by a low loss cable.
3. Set to the maximum power setting and enable the EUT transmit continuously.
4. Use the following spectrum analyzer settings:
Span = approximately 2 to 3 times the 20 dB bandwidth, centered on a hopping channel;
RBW \geq 1% of the 20 dB bandwidth; VBW \geq RBW; Sweep = auto; Detector function = peak;
Trace = max hold.

3.4.4 Test Setup

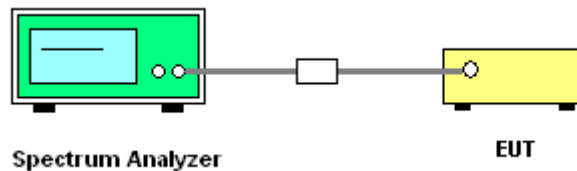



3.4.5 Test Result of 20dB Bandwidth

Test Mode :	1Mbps	Temperature :	24~26°C
Test Engineer :	Coyote Lin	Relative Humidity :	50~53%

Channel	Frequency (MHz)	20dB Bandwidth (MHz)
00	2402	0.952
39	2441	0.913
78	2480	0.913

20 dB Bandwidth Plot on Channel 00

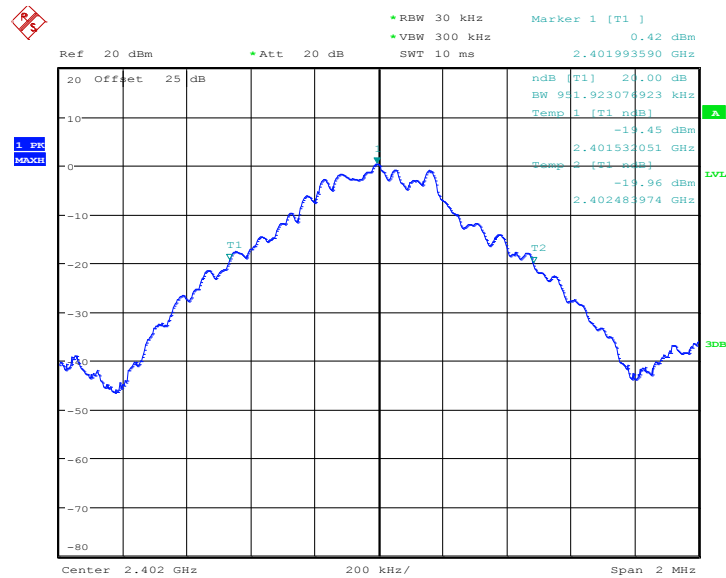

Date: 21.SEP.2012 13:35:36



20 dB Bandwidth Plot on Channel 39

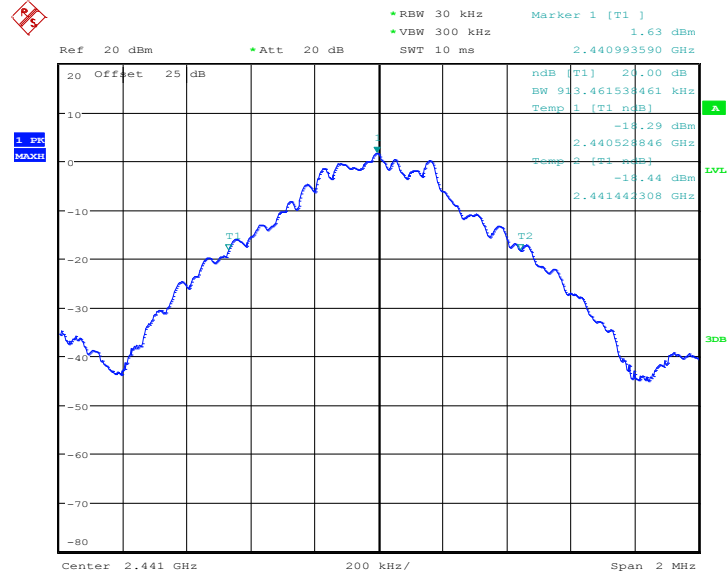

Date: 21.SEP.2012 13:36:20

20 dB Bandwidth Plot on Channel 78

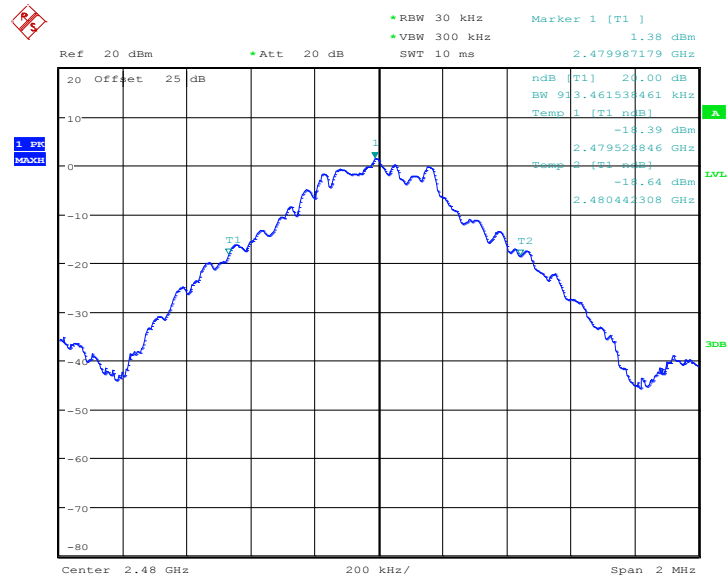

Date: 21.SEP.2012 13:37:34



Test Mode :	2Mbps	Temperature :	24~26°C
Test Engineer :	Coyote Lin	Relative Humidity :	50~53%

Channel	Frequency (MHz)	20dB Bandwidth (MHz)
00	2402	1.264
39	2441	1.264
78	2480	1.264

20 dB Bandwidth Plot on Channel 00

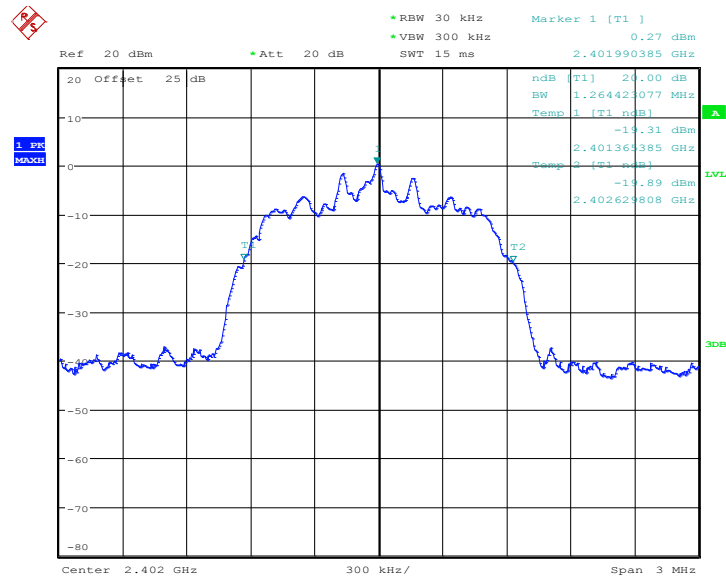

Date: 21.SEP.2012 13:38:12



20 dB Bandwidth Plot on Channel 39

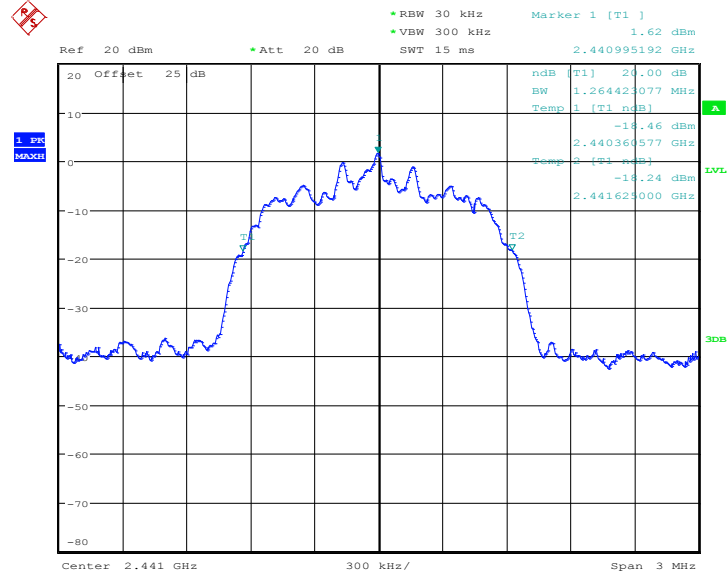

Date: 21.SEP.2012 13:38:42

20 dB Bandwidth Plot on Channel 78

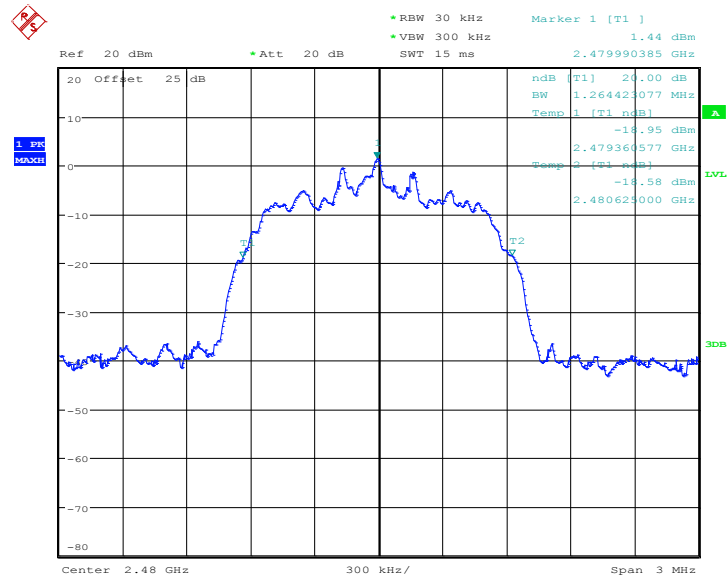

Date: 21.SEP.2012 13:53:50



Test Mode :	3Mbps	Temperature :	24~26°C
Test Engineer :	Coyote Lin	Relative Humidity :	50~53%

Channel	Frequency (MHz)	20dB Bandwidth (MHz)
00	2402	1.279
39	2441	1.279
78	2480	1.279

20 dB Bandwidth Plot on Channel 00

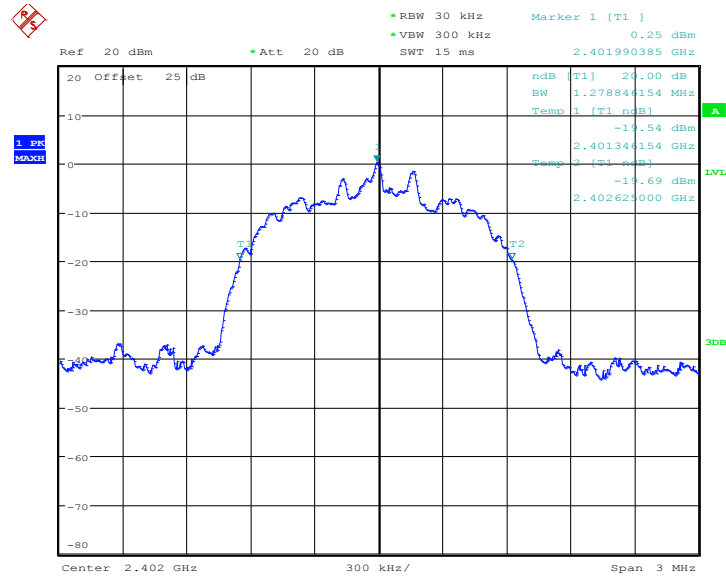

Date: 21.SEP.2012 13:40:00



20 dB Bandwidth Plot on Channel 39

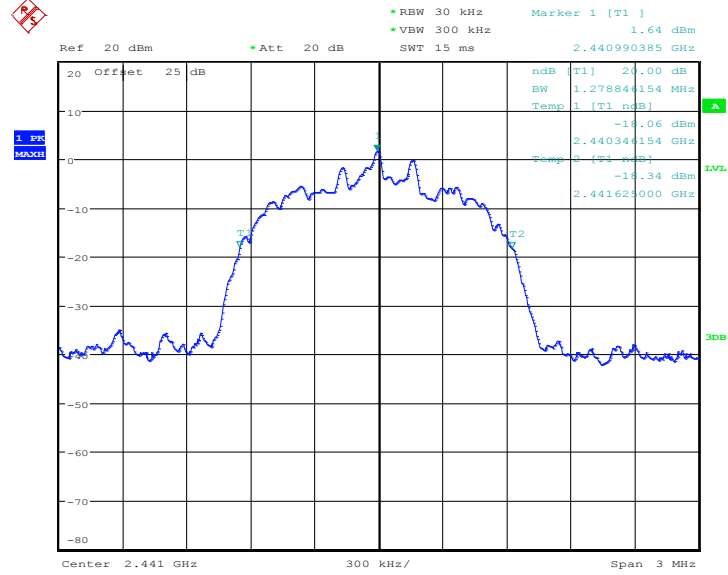

Date: 21.SEP.2012 13:41:31

20 dB Bandwidth Plot on Channel 78

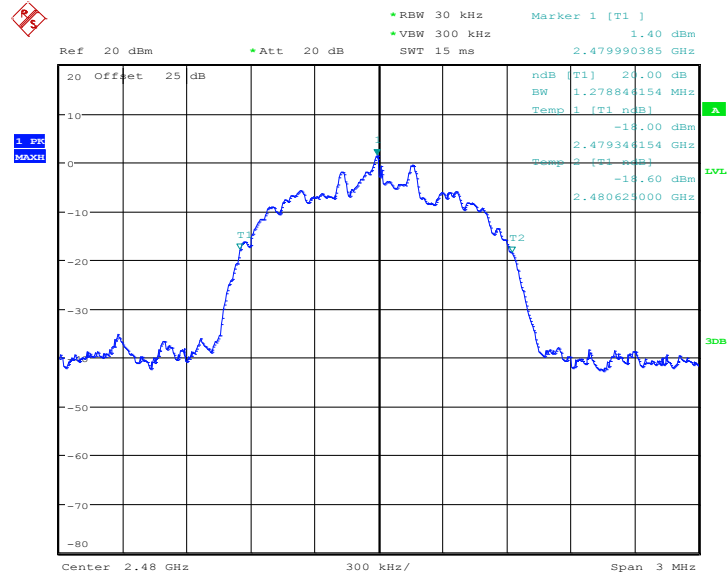

Date: 21.SEP.2012 13:43:49



3.4.6 Test Result of 99% Occupied Bandwidth

Test Mode :	1Mbps	Temperature :	24~26°C
Test Engineer :	Coyote Lin	Relative Humidity :	50~53%

Channel	Frequency (MHz)	99% Occupied Bandwidth (MHz)
00	2402	0.875
39	2441	0.872
78	2480	0.875

99% Bandwidth Plot on Channel 00

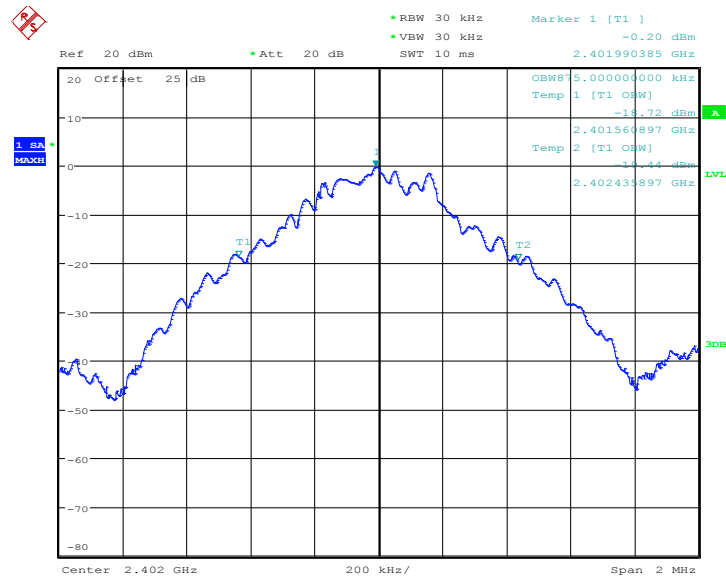

Date: 21.SEP.2012 13:56:22



99% Occupied Bandwidth Plot on Channel 39

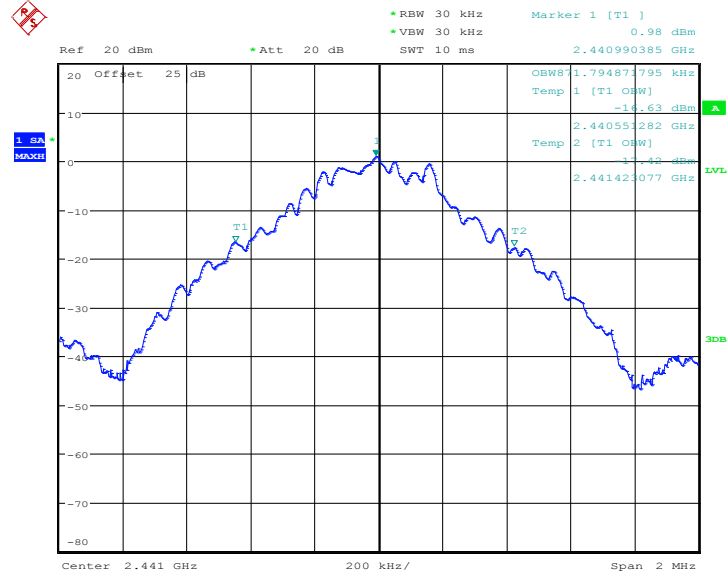

Date: 21.SEP.2012 13:56:59

99% Occupied Bandwidth Plot on Channel 78

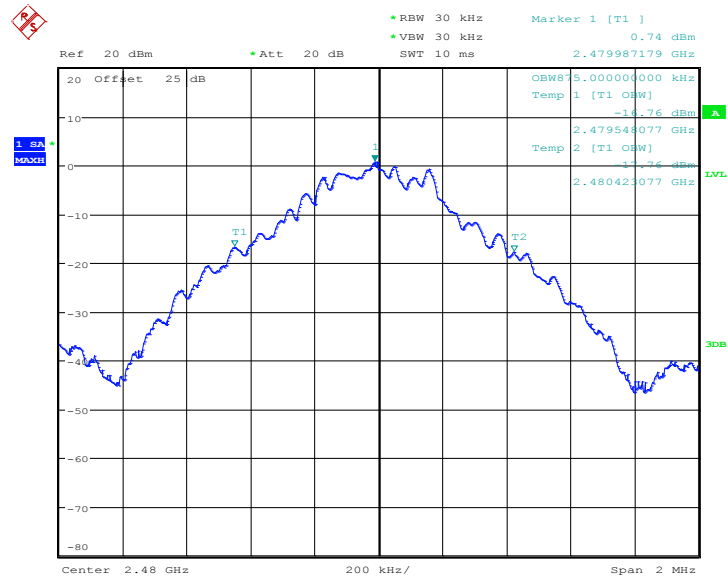

Date: 21.SEP.2012 14:27:55



Test Mode :	2Mbps	Temperature :	24~26°C
Test Engineer :	Coyote Lin	Relative Humidity :	50~53%

Channel	Frequency (MHz)	99% Occupied Bandwidth (MHz)
00	2402	1.163
39	2441	1.163
78	2480	1.163

99% Bandwidth Plot on Channel 00

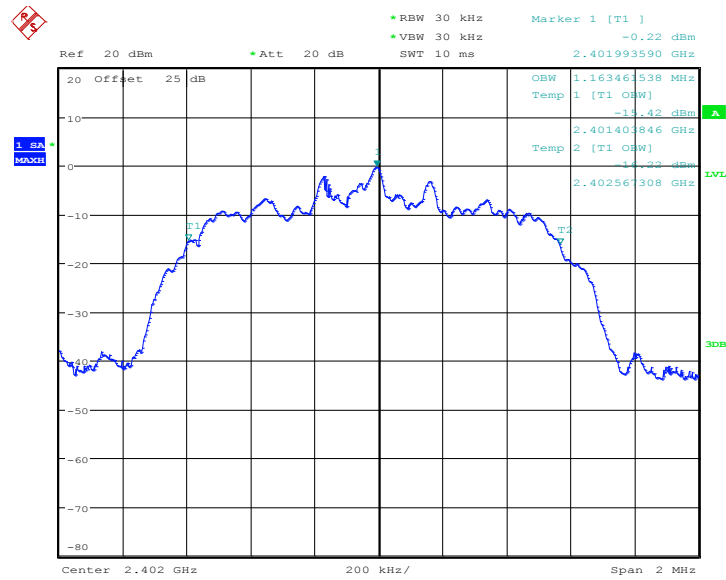

Date: 21.SEP.2012 14:07:22



99% Occupied Bandwidth Plot on Channel 39

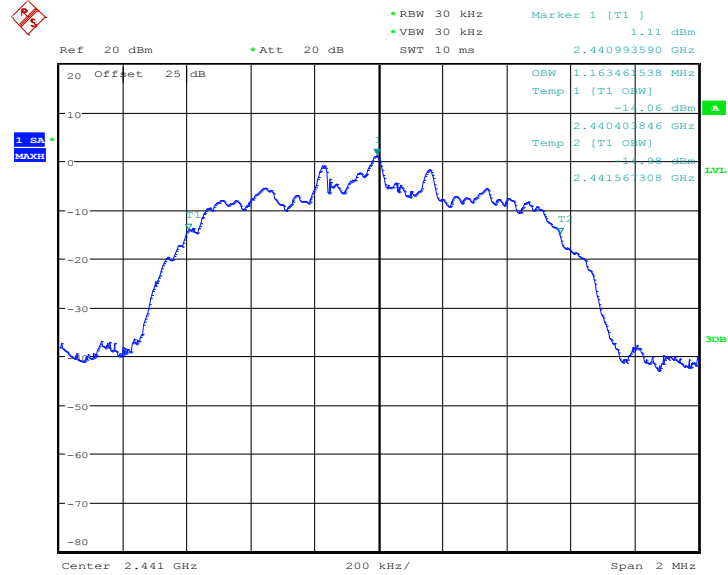

Date: 21.SEP.2012 13:58:48

99% Occupied Bandwidth Plot on Channel 78

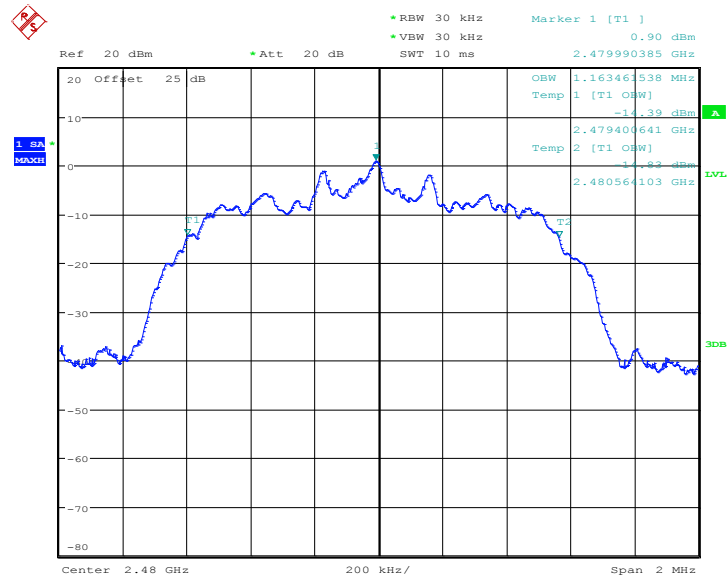

Date: 21.SEP.2012 14:08:22



Test Mode :	3Mbps	Temperature :	24~26°C
Test Engineer :	Coyote Lin	Relative Humidity :	50~53%

Channel	Frequency (MHz)	99% Occupied Bandwidth (MHz)
00	2402	1.170
39	2441	1.170
78	2480	1.173

99% Bandwidth Plot on Channel 00

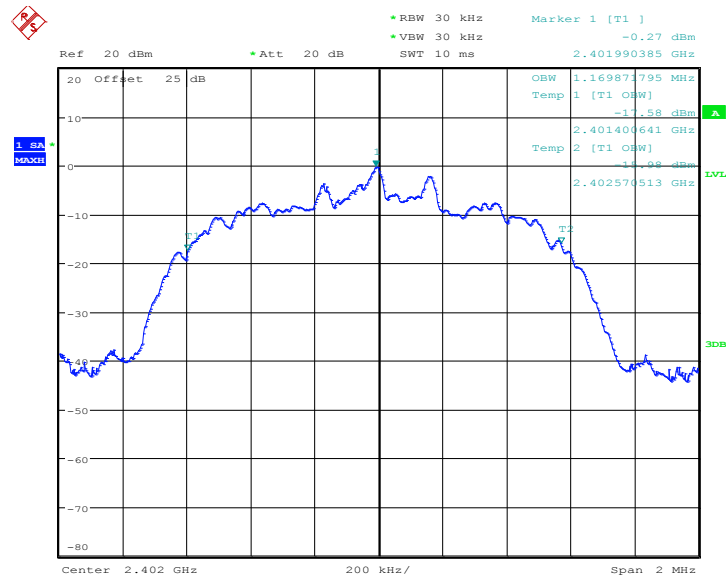

Date: 21.SEP.2012 14:09:41



99% Occupied Bandwidth Plot on Channel 39

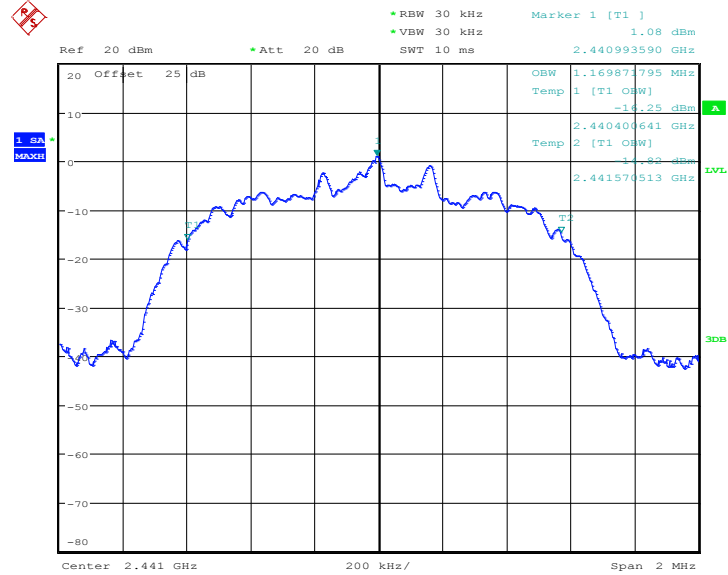

Date: 21.SEP.2012 14:00:43

99% Occupied Bandwidth Plot on Channel 78

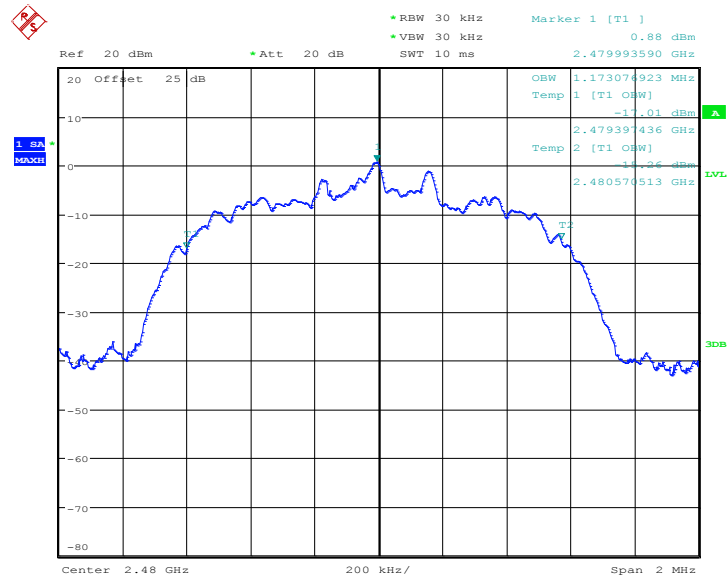

Date: 21.SEP.2012 14:09:01

3.5 Peak Output Power Measurement

3.5.1 Limit of Peak Output Power

Section 15.247 (b) The maximum peak conducted output power of the intentional radiator shall not exceed the following: (1) For frequency hopping systems operating in the 2400-2483.5 MHz band employing at least 75 non-overlapping hopping channels, and all frequency hopping systems in the 5725-5850 MHz band: 1 watt. For all other frequency hopping systems in the 2400-2483.5 MHz band 0.125 watts. The power limit for 1Mbps is 1watt, and for 2Mbps, and 3Mbps are 0.125 watts.

3.5.2 Measuring Instruments

See list of measuring instruments of this test report.

3.5.3 Test Procedures

1. The testing follows FCC Public Notice DA 00-705 Measurement Guidelines.
2. The RF output of EUT was connected to the spectrum analyzer by a low loss cable.
3. Set to the maximum power setting and enable the EUT transmit continuously.
4. Measure the conducted output power and record the results in the test report.

3.5.4 Test Setup

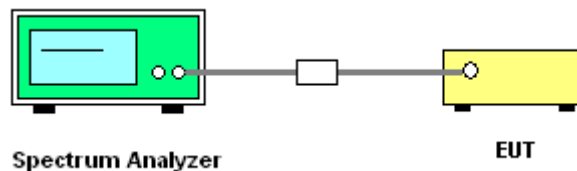



3.5.5 Test Result of Peak Output Power

Test Mode :	1Mbps	Temperature :	24~26°C
Test Engineer :	Coyote Lin	Relative Humidity :	50~53%

Channel	Frequency (MHz)	RF Power (dBm)		
		GFSK	Max. Limits (dBm)	Pass/Fail
		1 Mbps		
00	2402	2.33	30.00	Pass
39	2441	3.40	30.00	Pass
78	2480	3.25	30.00	Pass

Peak Output Power Plot on Channel 00

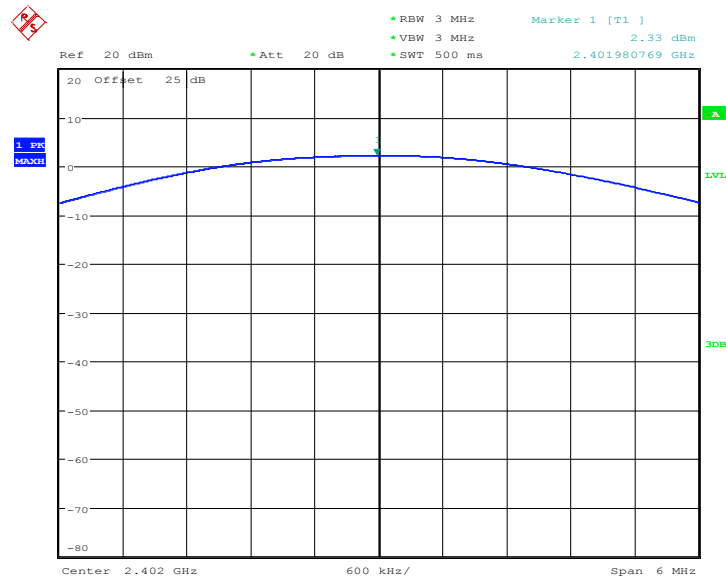

Date: 21.SEP.2012 09:41:34



Peak Output Power Plot on Channel 39

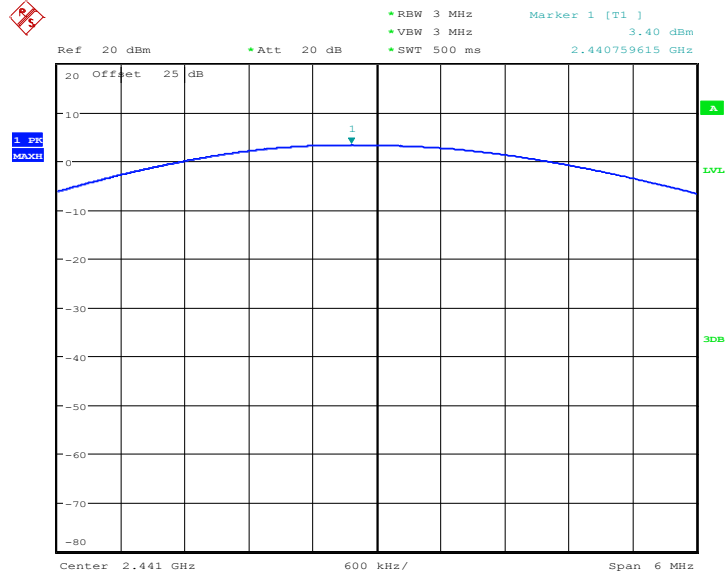

Date: 21.SEP.2012 09:50:25

Peak Output Power Plot on Channel 78

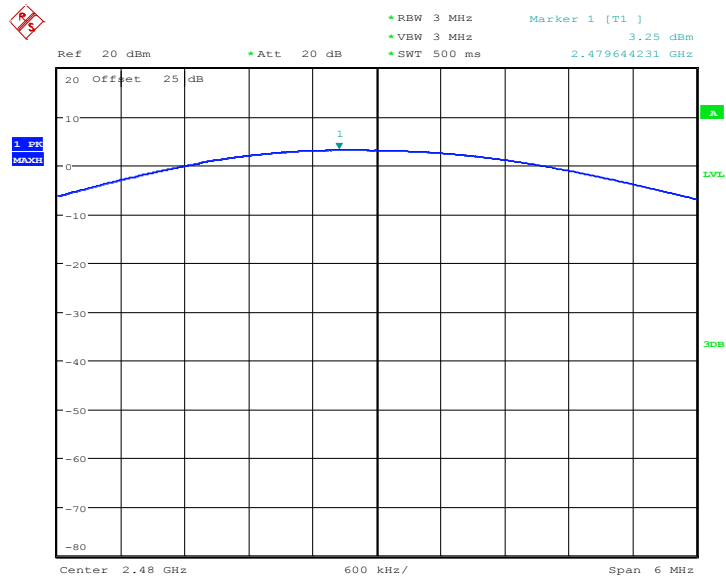

Date: 21.SEP.2012 09:44:14



Test Mode :	2Mbps	Temperature :	24~26°C
Test Engineer :	Coyote Lin	Relative Humidity :	50~53%

Channel	Frequency (MHz)	RF Power (dBm)		
		π /4-DQPSK	Max. Limits (dBm)	Pass/Fail
		2 Mbps		
00	2402	3.04	20.97	Pass
39	2441	4.34	20.97	Pass
78	2480	4.12	20.97	Pass

Peak Output Power Plot on Channel 00

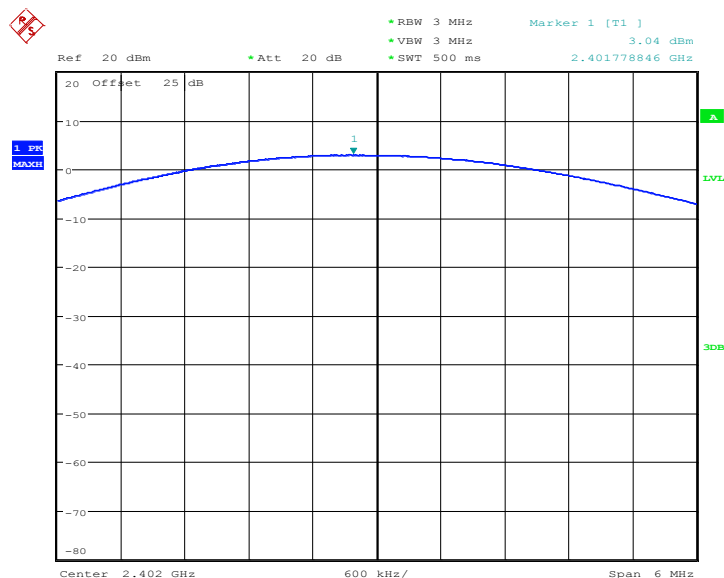

Date: 21.SEP.2012 09:42:00



Peak Output Power Plot on Channel 39

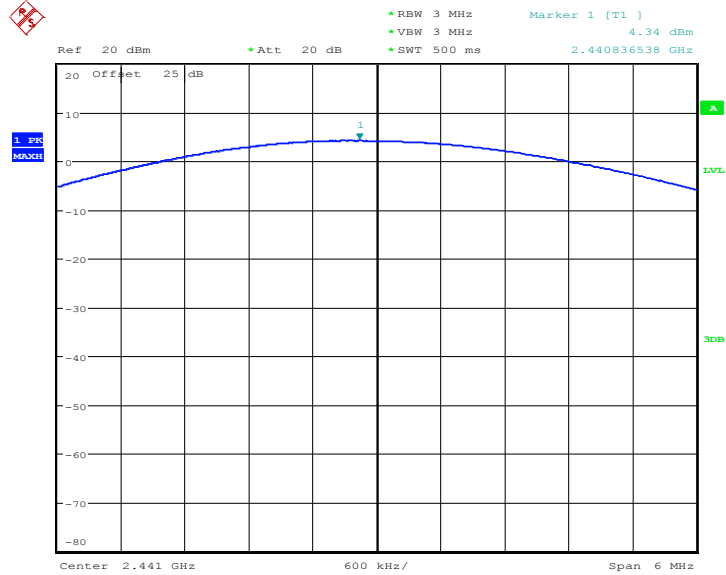

Date: 21.SEP.2012 09:48:18

Peak Output Power Plot on Channel 78

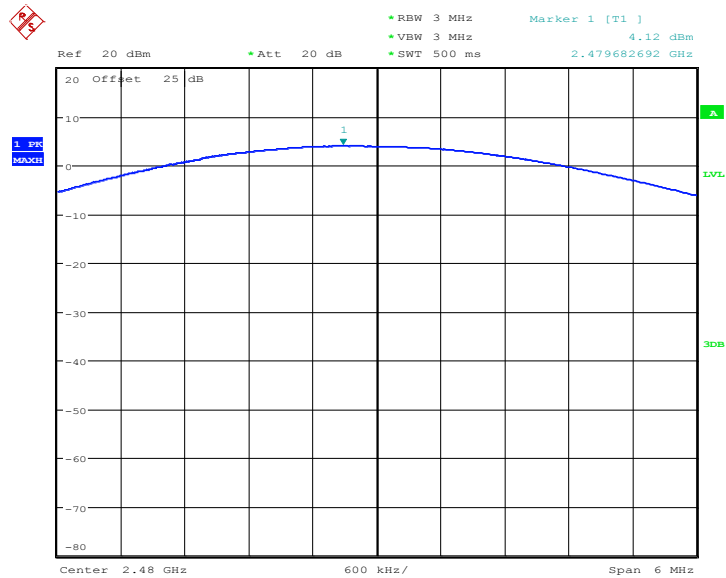

Date: 21.SEP.2012 09:44:49



Test Mode :	3Mbps	Temperature :	24~26°C
Test Engineer :	Coyote Lin	Relative Humidity :	50~53%

Channel	Frequency (MHz)	RF Power (dBm)		
		8-DPSK	Max. Limits (dBm)	Pass/Fail
		3 Mbps		
00	2402	3.39	20.97	Pass
39	2441	4.69	20.97	Pass
78	2480	4.48	20.97	Pass

Peak Output Power Plot on Channel 00

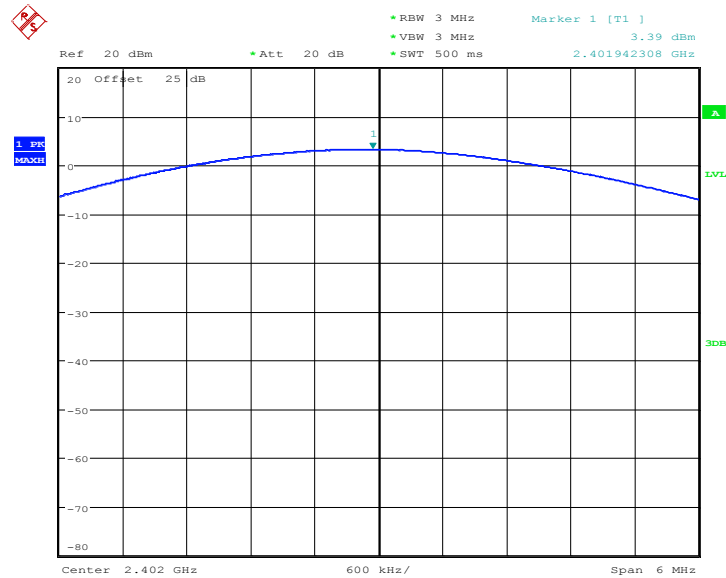

Date: 21.SEP.2012 09:42:25



Peak Output Power Plot on Channel 39

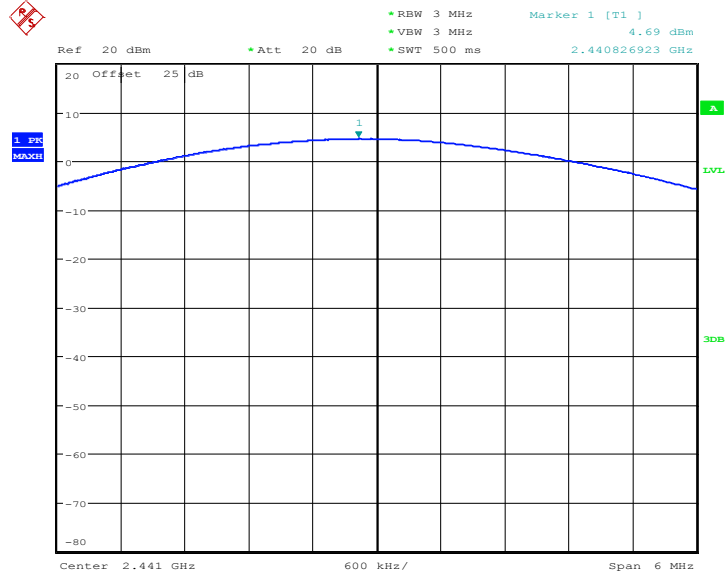

Date: 21.SEP.2012 09:53:14

Peak Output Power Plot on Channel 78

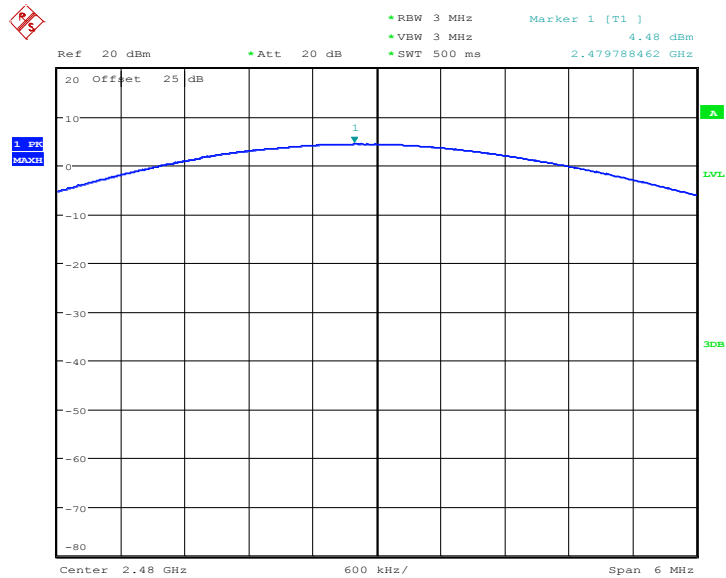

Date: 21.SEP.2012 09:46:28

3.6 Conducted Band Edges Measurement

3.6.1 Limit of Band Edges

In any 100 KHz bandwidth outside the intentional radiation frequency band, the radio frequency power shall be at least 20 dB below the highest level of the radiated power. In addition, radiated emissions which fall in the restricted bands must also comply with the radiated emission limits.

3.6.2 Measuring Instruments

See list of measuring instruments of this test report.

3.6.3 Test Procedures

1. The testing follows the guidelines in Band-edge Compliance of RF Conducted Emissions of FCC Public Notice DA 00-705 Measurement Guidelines.
2. Set to the maximum power setting and enable the EUT transmit continuously.
3. Set RBW = 300KHz ($\geq 1\%$ span=30MHz), VBW = 300KHz (\geq RBW). Band edge emissions must be at least 20 dB down from the highest emission level within the authorized band as measured with a 300KHz RBW. The attenuation shall be 30 dB instead of 20 dB when RMS conducted output power procedure is used.
4. Enable hopping function of the EUT and then repeat step 2. and 3.
5. Record the results in the test report.

3.6.4 Test Setup

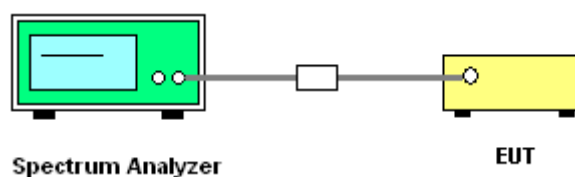



3.6.5 Test Result of Conducted Band Edges

Test Mode :	3Mbps	Temperature :	24~26°C
Test Channel :	00 and 78	Relative Humidity :	50~53%
		Test Engineer :	Coyote Lin

Low Band Edge Plot on Channel 00

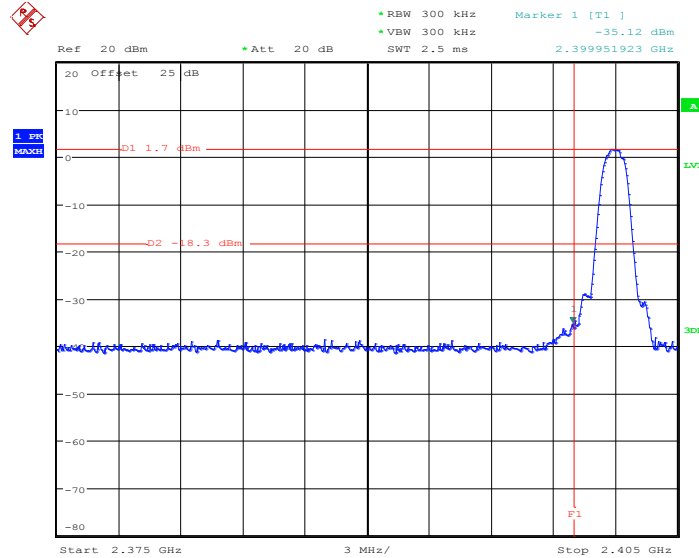

Date: 21.SEP.2012 13:48:38

High Band Edge Plot on Channel 78

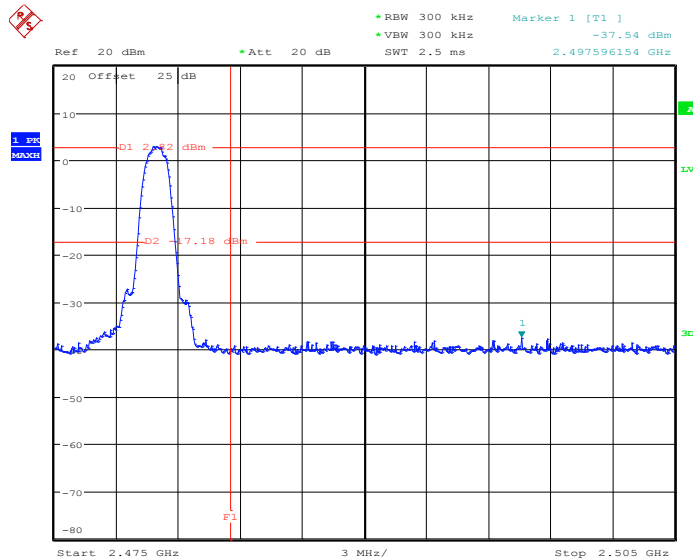

Date: 21.SEP.2012 13:49:42



3.6.6 Test Result of Conducted Hopping Mode Band Edges

Test Mode :	3Mbps	Temperature :	24~26°C
Test Engineer :	Coyote Lin	Relative Humidity :	50~53%

Hopping Mode Low Band Edge Plot

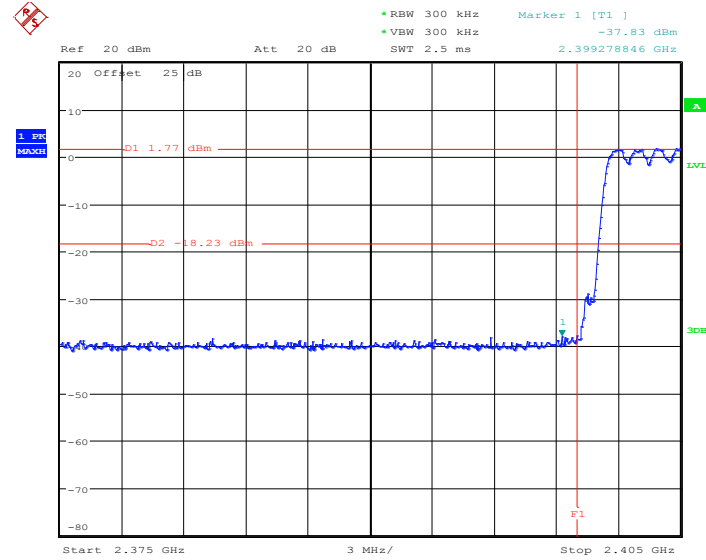

Date: 21.SEP.2012 15:48:18

Hopping Mode High Band Edge Plot

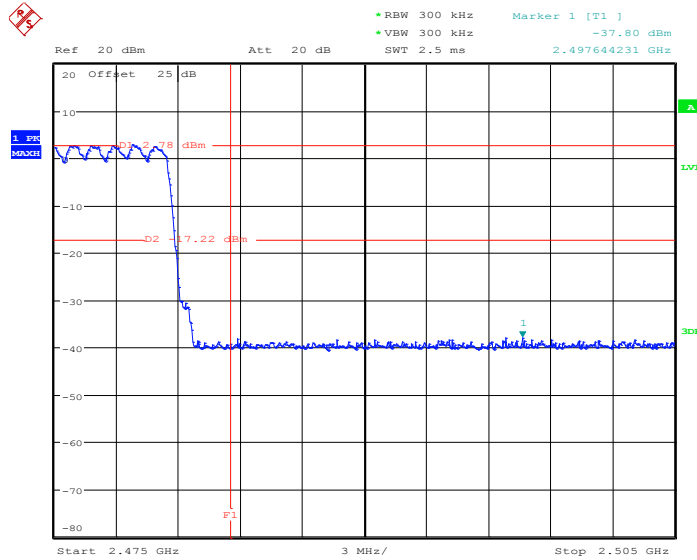

Date: 21.SEP.2012 15:53:31

3.7 Conducted Spurious Emission Measurement

3.7.1 Limit of Spurious Emission Measurement

In any 100 KHz bandwidth outside the intentional radiation frequency band, the radio frequency power shall be at least 20 dB below the highest level of the radiated power. In addition, radiated emissions which fall in the restricted bands must also comply with the radiated emission limits.

3.7.2 Measuring Instruments

See list of measuring instruments of this test report.

3.7.3 Test Procedure

1. The testing follows the guidelines in Spurious RF Conducted Emissions of FCC Public Notice DA 00-705 Measurement Guidelines
2. The transmitter output was connected to the spectrum analyzer via a low loss cable.
3. Set to the maximum power setting and enable the EUT transmit continuously.
4. Set RBW = 100 KHz, VBW = 300KHz, scan up through 10th harmonic. All harmonics / spurs must be at least 20 dB down from the highest emission level within the authorized band as measured with a 100 KHz RBW.
5. Record the results in the test report.

3.7.4 Test Setup

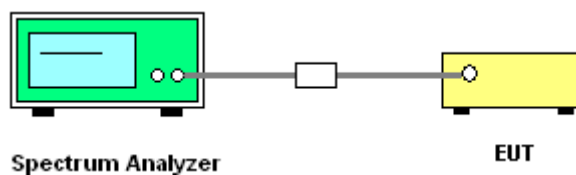



3.7.5 Test Result

Test Mode :	3Mbps	Temperature :	24~26°C
Test Channel :	00	Relative Humidity :	50~53%
		Test Engineer :	Coyote Lin

Conducted Spurious Emission Plot between 30MHz ~ 3 GHz

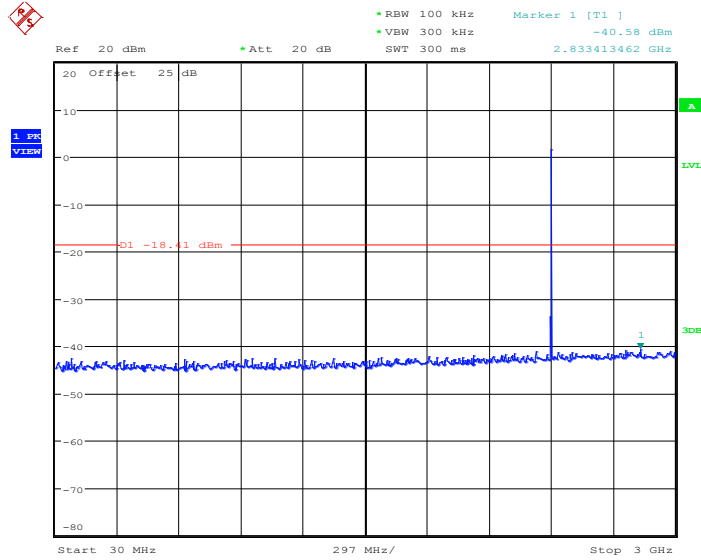

Date: 21.SEP.2012 15:12:36

Conducted Spurious Emission Plot between 2 GHz ~ 25 GHz

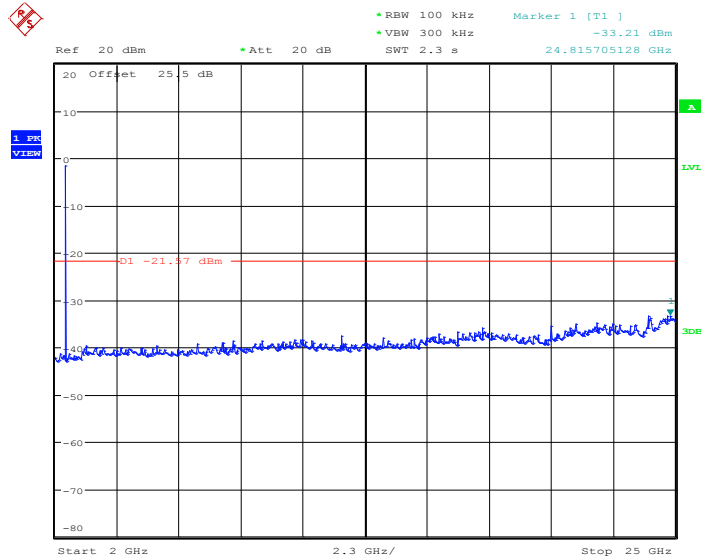

Date: 21.SEP.2012 15:13:28



Test Mode :	3Mbps	Temperature :	24~26°C
Test Channel :	39	Relative Humidity :	50~53%
		Test Engineer :	Coyote Lin

Conducted Spurious Emission Plot between 30MHz ~ 3 GHz

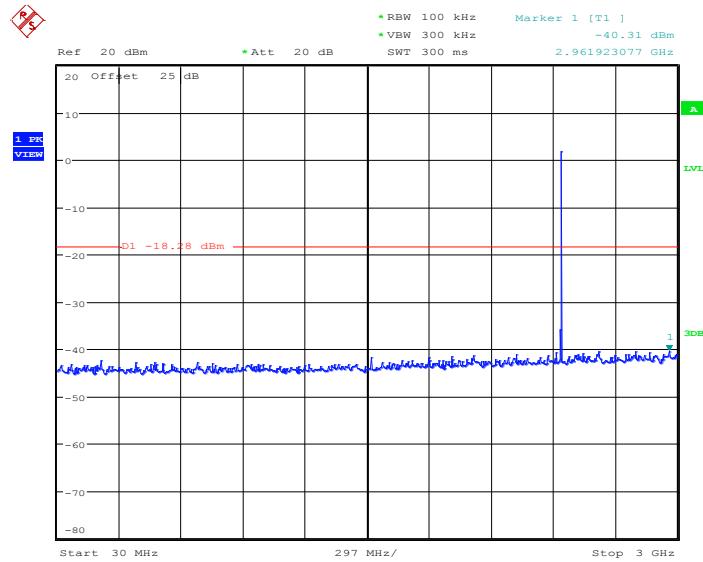

Date: 21.SEP.2012 15:14:20

Conducted Spurious Emission Plot between 2 GHz ~ 25 GHz

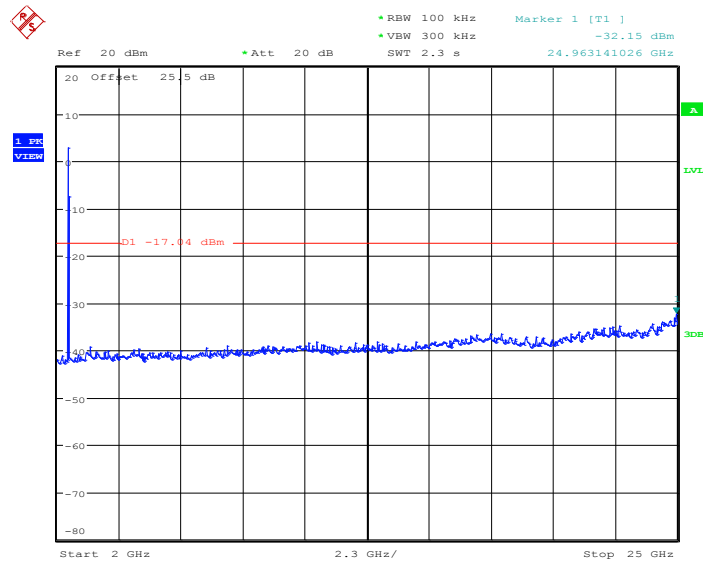

Date: 21.SEP.2012 15:15:12



Test Mode :	3Mbps	Temperature :	24~26°C
Test Channel :	78	Relative Humidity :	50~53%
		Test Engineer :	Coyote Lin

Conducted Spurious Emission Plot between 30MHz ~ 3 GHz

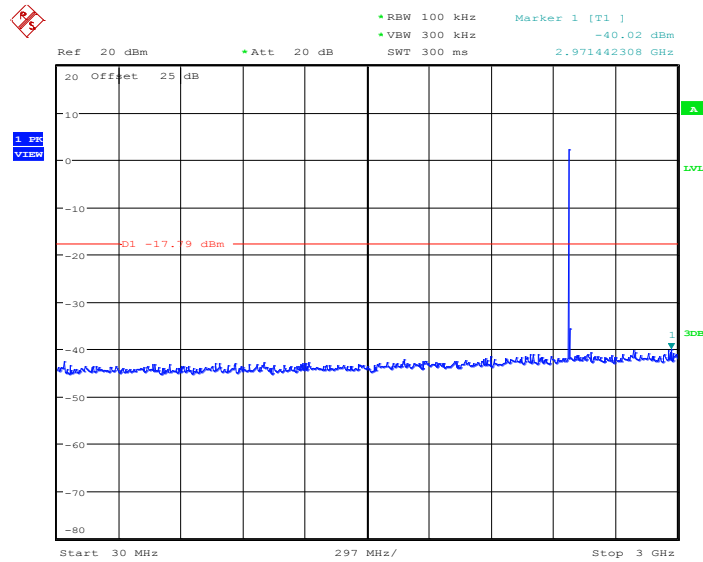

Date: 21.SEP.2012 15:16:05

Conducted Spurious Emission Plot between 2 GHz ~ 25 GHz

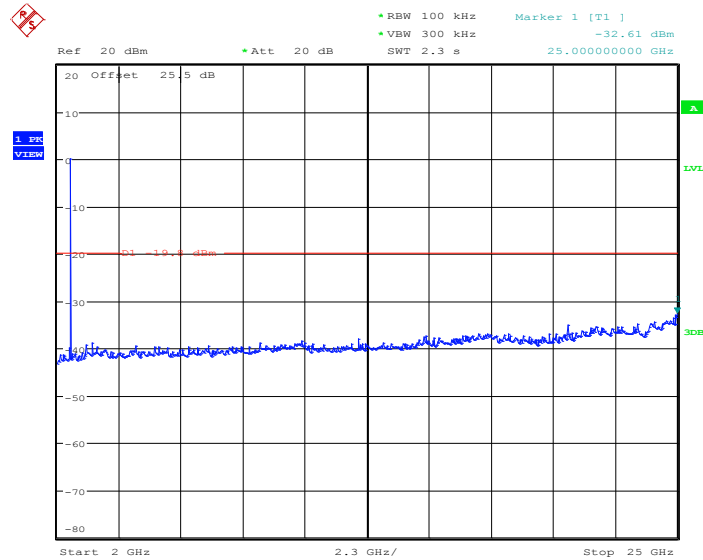

Date: 21.SEP.2012 15:16:56



3.8 Radiated Band Edges and Spurious Emission Measurement

3.8.1 Limit of Radiated Band Edges and Spurious Emission

In any 100 KHz bandwidth outside the intentional radiator frequency band, all harmonics/spurious must be at least 20 dB below the highest emission level within the authorized band. In addition, radiated emissions which fall in the restricted bands must also comply with the FCC section 15.209 limits as below.

Frequency (MHz)	Field Strength (microvolts/meter)	Measurement Distance (meters)
0.009 – 0.490	2400/F(KHz)	300
0.490 – 1.705	24000/F(KHz)	30
1.705 – 30.0	30	30
30 – 88	100	3
88 – 216	150	3
216 - 960	200	3
Above 960	500	3

3.8.2 Measuring Instruments

See list of measuring instruments of this test report.



3.8.3 Test Procedures

1. The testing follows the guidelines in Spurious Radiated Emissions of FCC Public Notice DA 00-705 Measurement Guidelines and fulfills ANSI C63.4-2003 and the guidelines in ANSI C63.10-2009 test site requirement.
2. The EUT was placed on a turntable with 0.8 meter above ground.
3. The EUT was set 3 meters from the interference receiving antenna, which was mounted on the top of a variable height antenna tower.
4. For each suspected emission, the EUT was arranged to its worst case and then tune the Antenna tower (from 1 m to 4 m) and turntable (from 0 degree to 360 degrees) to find the maximum reading. A pre-amp and a high pass filter are used for the test in order to get better signal level to comply with the guidelines.
5. Set to the maximum power setting and enable the EUT transmit continuously.
6. Use the following spectrum analyzer settings:
 - (1) Span shall wide enough to fully capture the emission being measured;
 - (2) Set RBW=100 KHz for $f < 1 \text{ GHz}$, RBW=1MHz for $f > 1 \text{ GHz}$; VBW \geq RBW; Sweep = auto; Detector function = peak; Trace = max hold for peak
 - (3) For average measurement: use duty cycle correction factor method per 15.35(c).
Duty cycle = On time/100 milliseconds
On time = $N_1 * L_1 + N_2 * L_2 + \dots + N_{n-1} * L_{n-1} + N_n * L_n$
Where N_1 is number of type 1 pulses, L_1 is length of type 1 pulses, etc.
Average Level = Peak Level + $20 * \log(\text{Duty cycle})$
7. Corrected Reading: Antenna Factor + Cable Loss + Read Level - Preamp Factor = Level

Note: The average levels were calculated from the peak level corrected with duty cycle correction factor (24.73dB) derived from $20 \log(\text{dwell time}/100\text{ms})$.

For example: Average level = $47.70\text{dBuV/m} - 24.73 \text{ (dB)} = 22.97\text{dBuV/m}$.

3.8.4 Test Setup

For radiated emissions below 30MHz

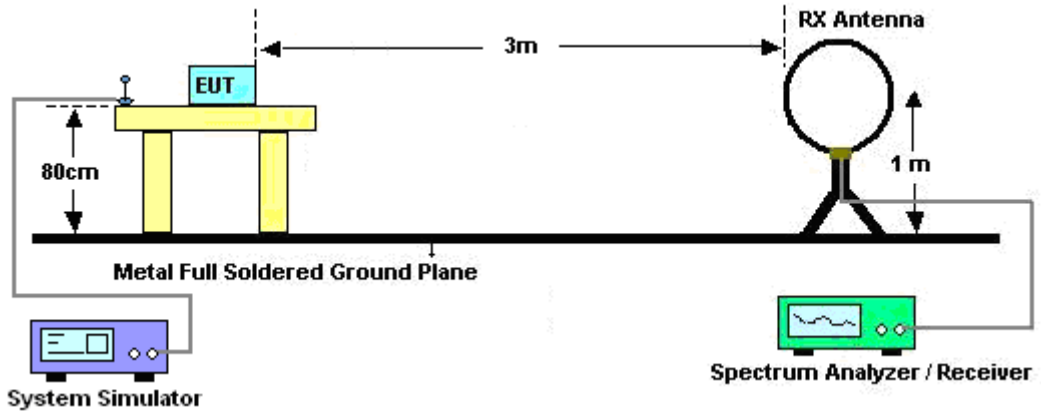

For radiated emissions from 30MHz to 1GHz

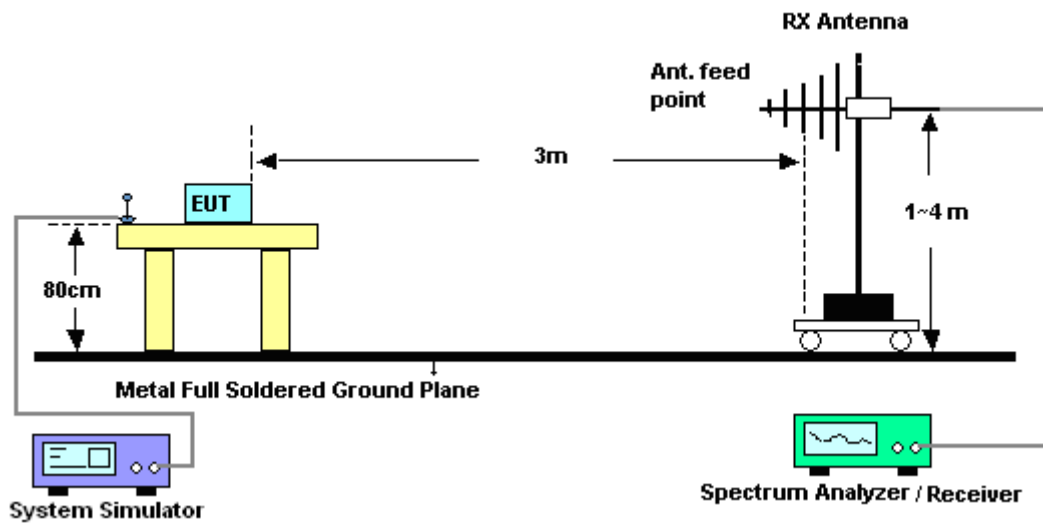

For radiated emissions above 1GHz

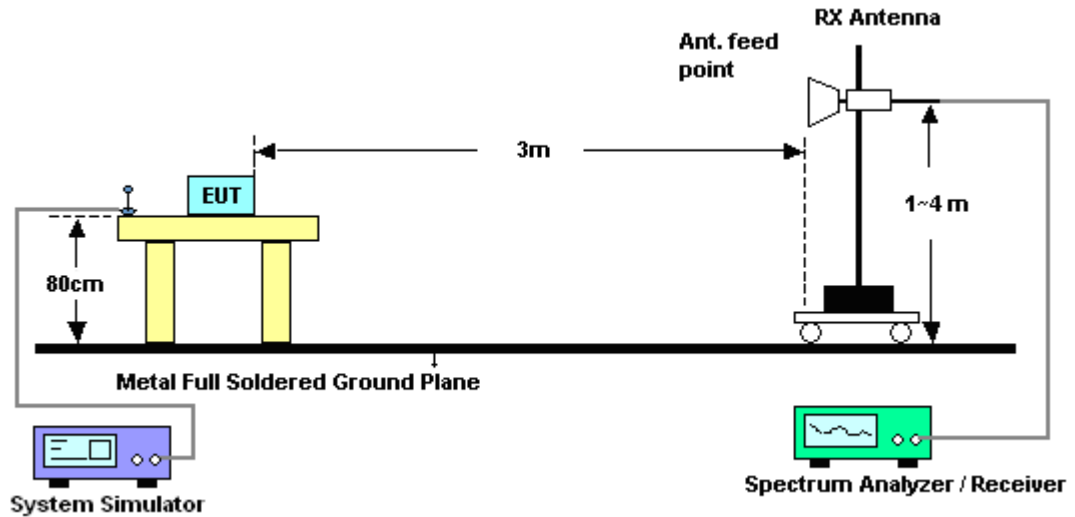

3.8.5 Test Results of Radiated Emissions (9 KHz ~ 30 MHz)

The low frequency, which started from 9 KHz to 30MHz, was pre-scanned and the result which was 20dB lower than the limit line per 15.31(o) was not reported.

3.8.6 Duty cycle correction factor for average measurement

3DH5 on time/100ms (One Pulse) Plot on Channel 39

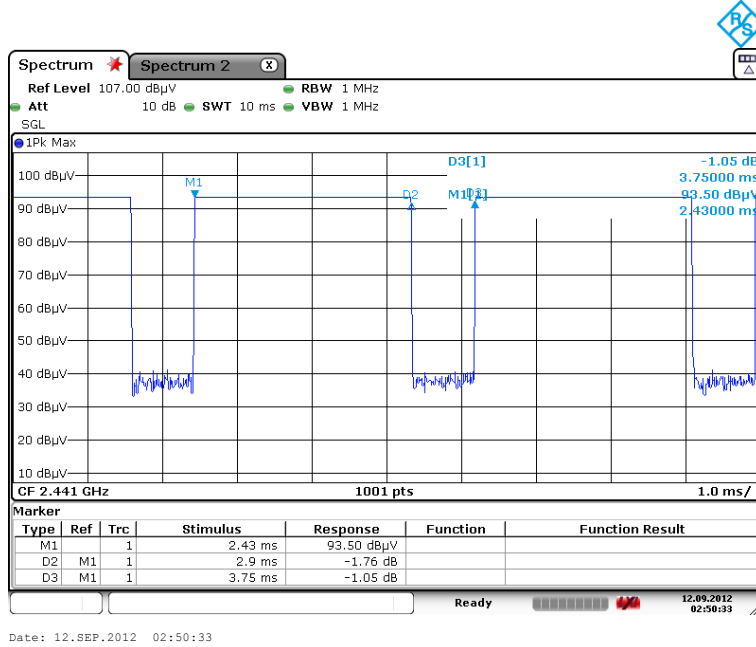

3DH5 on time/100ms (Count Pulses) Plot on Channel 39

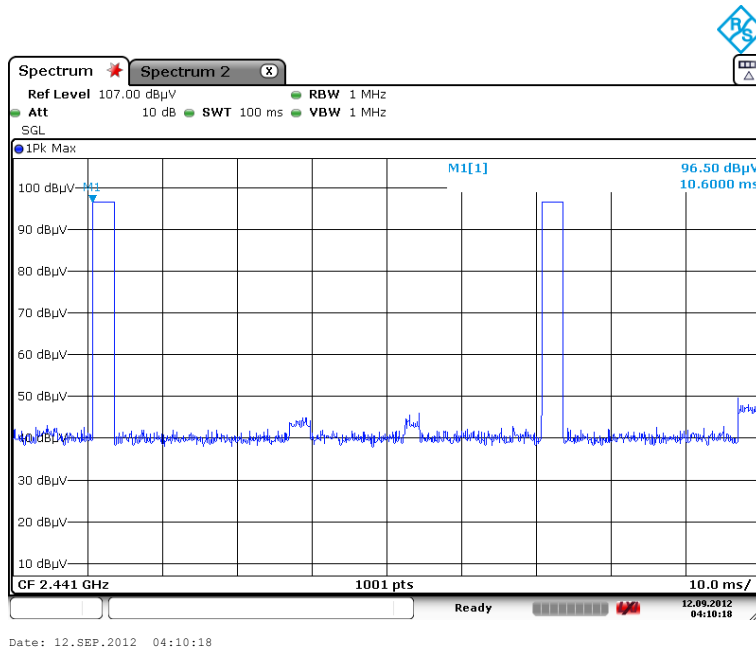

Note:

1. Duty cycle = on time/100 milliseconds = $2 * 2.90 / 100 = 5.80 \%$
2. Duty cycle correction factor = $20 * \log(\text{Duty cycle}) = -24.73 \text{ dB}$
3. 3DH5 has the highest duty cycle and is reported.



3.8.7 Test Result of Radiated Band Edges

Test Mode :	3Mbps	Temperature :	30~31°C
Test Channel :	00	Relative Humidity :	42~43%
		Test Engineer :	Kai Wang

ANTENNA POLARITY : HORIZONTAL										
Frequency (MHz)	Level (dBμV/m)	Over Limit (dB)	Limit Line (dBμV/m)	Read Level (dBμV)	Antenna Factor (dB)	Cable Loss (dB)	Preamp Factor (dB)	Ant Pos (cm)	Table Pos (deg)	Remark
2337	47.70	-26.3	74	43.61	32.28	6.38	34.57	110	22	Peak
2337	22.97	-31.03	54	-	-	-	-	-	-	Average

ANTENNA POLARITY : VERTICAL										
Frequency (MHz)	Level (dBμV/m)	Over Limit (dB)	Limit Line (dBμV/m)	Read Level (dBμV)	Antenna Factor (dB)	Cable Loss (dB)	Preamp Factor (dB)	Ant Pos (cm)	Table Pos (deg)	Remark
2364.27	46.81	-27.19	74	42.64	32.31	6.42	34.56	103	10	Peak
2364.27	22.08	-31.92	54	-	-	-	-	-	-	Average

Note: The average levels were calculated from the peak level corrected with duty cycle correction factor (24.73dB) derived from 20log (dwell time/100ms).

For example: Average level = 47.70dBuV/m – 24.73 (dB) = 22.97dBuV/m.

Test Mode :	3Mbps	Temperature :	30~31°C
Test Channel :	78	Relative Humidity :	42~43%
		Test Engineer :	Kai Wang

ANTENNA POLARITY : HORIZONTAL										
Frequency (MHz)	Level (dBμV/m)	Over Limit (dB)	Limit Line (dBμV/m)	Read Level (dBμV)	Antenna Factor (dB)	Cable Loss (dB)	Preamp Factor (dB)	Ant Pos (cm)	Table Pos (deg)	Remark
2483.5	52.94	-21.06	74	48.42	32.48	6.59	34.55	100	25	Peak
2483.5	28.21	-25.79	54	-	-	-	-	-	-	Average

ANTENNA POLARITY : VERTICAL										
Frequency (MHz)	Level (dBμV/m)	Over Limit (dB)	Limit Line (dBμV/m)	Read Level (dBμV)	Antenna Factor (dB)	Cable Loss (dB)	Preamp Factor (dB)	Ant Pos (cm)	Table Pos (deg)	Remark
2488.62	48.22	-25.78	74	43.68	32.5	6.59	34.55	153	12	Peak
2488.62	23.49	-30.51	54	-	-	-	-	-	-	Average

3.8.8 Test Result of Radiated Emission (30 MHz ~ 10th Harmonic)

Test Mode :	3Mbps	Temperature :	30~31°C
Test Channel :	00	Relative Humidity :	42~43%
Test Engineer :	Kai Wang	Polarization :	Horizontal
Remark :	1. 2402 MHz is fundamental signal which can be ignored. 2. 2506 MHz is not within a restricted band, and its limit line is 20dB below the highest emission level. For example, 101.17 dBuV/m - 20dB = 81.17 dBuV/m. 3. Average measurement was not performed if peak level went lower than the average limit.		

Frequency (MHz)	Level (dBμV/m)	Over Limit (dB)	Limit Line (dBμV/m)	Read Level (dBμV)	Antenna Factor (dB)	Cable Loss (dB)	Preamp Factor (dB)	Ant Pos (cm)	Table Pos (deg)	Remark
2402	101.17	-	-	96.92	32.36	6.45	34.56	110	22	Peak
2402	76.44	-	-	-	-	-	-	-	-	Average
2506	52.21	-28.96	81.17	47.6	32.52	6.64	34.55	100	0	Peak
4804	49.21	-24.79	74	59.72	34.88	10.17	55.56	100	0	Peak

Note: The average levels were calculated from the peak level corrected with duty cycle correction factor (24.73dB) derived from 20log (dwell time/100ms).

For example: Average level = 101.17dBuV/m – 24.73 (dB) = 76.44dBuV/m.

Test Mode :	3Mbps	Temperature :	30~31°C
Test Channel :	00	Relative Humidity :	42~43%
Test Engineer :	Kai Wang	Polarization :	Vertical
Remark :	1. 2402 MHz is fundamental signal which can be ignored. 2. Average measurement was not performed if peak level went lower than the average limit.		

Frequency (MHz)	Level (dBμV/m)	Over Limit (dB)	Limit Line (dBμV/m)	Read Level (dBμV)	Antenna Factor (dB)	Cable Loss (dB)	Preamp Factor (dB)	Ant Pos (cm)	Table Pos (deg)	Remark
2402	97.4	-	-	93.15	32.36	6.45	34.56	103	10	Peak
2402	72.67	-	-	-	-	-	-	-	-	Average
4804	50.39	-23.61	74	60.9	34.88	10.17	55.56	100	0	Peak



Test Mode :	3Mbps	Temperature :	30~31°C
Test Channel :	39	Relative Humidity :	42~43%
Test Engineer :	Kai Wang	Polarization :	Horizontal
Remark :	1. 2441 MHz is fundamental signal which can be ignored. 2. 2546 MHz is not within a restricted band, and its limit line is 20dB below the highest emission level. 3. Average measurement was not performed if peak level went lower than the average limit.		

Frequency (MHz)	Level (dBμV/m)	Over Limit (dB)	Limit Line (dBμV/m)	Read Level (dBμV)	Antenna Factor (dB)	Cable Loss (dB)	Preamp Factor (dB)	Ant Pos (cm)	Table Pos (deg)	Remark
2441	101.6	-	-	97.21	32.43	6.52	34.56	103	22	Peak
2441	76.87	-	-	-	-	-	-	-	-	Average
2546	52.71	-28.89	81.6	48	32.56	6.69	34.54	100	0	Peak
4882	50.62	-23.38	74	61.26	34.85	10.19	55.68	100	0	Peak

Test Mode :	3Mbps	Temperature :	30~31°C
Test Channel :	39	Relative Humidity :	42~43%
Test Engineer :	Kai Wang	Polarization :	Vertical
Remark :	2441 MHz is fundamental signal which can be ignored.		

Frequency (MHz)	Level (dBμV/m)	Over Limit (dB)	Limit Line (dBμV/m)	Read Level (dBμV)	Antenna Factor (dB)	Cable Loss (dB)	Preamp Factor (dB)	Ant Pos (cm)	Table Pos (deg)	Remark
2441	98.12	-	-	93.73	32.43	6.52	34.56	102	12	Peak
2441	73.39	-	-	-	-	-	-	-	-	Average
4882	51.17	-22.83	74	61.81	34.85	10.19	55.68	100	0	Peak
4882	26.44	-27.56	54	-	-	-	-	-	-	Average



Test Mode :	3Mbps	Temperature :	30~31°C
Test Channel :	78	Relative Humidity :	42~43%
Test Engineer :	Kai Wang	Polarization :	Horizontal
Remark :	1. 2480MHz is fundamental signal which can be ignored. 2. 2584MHz is not within a restricted band, and its limit line is 20dB below the highest emission level. 3. Average measurement was not performed if peak level went lower than the average limit.		

Frequency (MHz)	Level (dBμV/m)	Over Limit (dB)	Limit Line (dBμV/m)	Read Level (dBμV)	Antenna Factor (dB)	Cable Loss (dB)	Preamp Factor (dB)	Ant Pos (cm)	Table Pos (deg)	Remark
30	17.22	-22.78	40	29.33	18.8	0.64	31.55	-	-	Peak
205.23	23.53	-19.97	43.5	44.31	9.08	1.56	31.42	-	-	Peak
256.26	25.7	-20.3	46	41.87	13.18	1.77	31.12	-	-	Peak
343.4	26.23	-19.77	46	41.17	14.02	2.02	30.98	100	169	Peak
456.1	24.48	-21.52	46	36.24	16.98	2.32	31.06	-	-	Peak
946.8	24.48	-21.52	46	30.38	20.87	3.35	30.12	-	-	Peak
2480	102.03	-	-	97.51	32.48	6.59	34.55	100	25	Peak
2480	77.3	-	-	-	-	-	-	-	-	Average
2584	53.27	-28.76	82.03	48.43	32.6	6.78	34.54	100	0	Peak
4960	49.2	-24.8	74	60.02	34.81	10.21	55.84	100	0	Peak



Test Mode :	3Mbps	Temperature :	30~31°C
Test Channel :	78	Relative Humidity :	42~43%
Test Engineer :	Kai Wang	Polarization :	Vertical
Remark :	1. 2480 MHz is fundamental signal which can be ignored. 2. Average measurement was not performed if peak level went lower than the average limit.		

Frequency (MHz)	Level (dBμV/m)	Over Limit (dB)	Limit Line (dBμV/m)	Read Level (dBμV)	Antenna Factor (dB)	Cable Loss (dB)	Preamp Factor (dB)	Ant Pos (cm)	Table Pos (deg)	Remark
30.81	17.15	-22.85	40	30.02	18.02	0.65	31.54	-	-	Peak
201.45	30.22	-13.28	43.5	51.07	9.23	1.55	31.63	-	-	Peak
209.82	30.52	-12.98	43.5	51.18	8.94	1.57	31.17	100	218	Peak
344.1	23.65	-22.35	46	38.54	14.06	2.03	30.98	-	-	Peak
468.7	27.29	-18.71	46	38.75	17.18	2.32	30.96	-	-	Peak
632.5	24.94	-21.06	46	34.33	19.2	2.79	31.38	-	-	Peak
2480	99.46	-	-	94.94	32.48	6.59	34.55	153	12	Peak
2480	74.73	-	-	-	-	-	-	-	-	Average
4960	50.66	-23.34	74	61.48	34.81	10.21	55.84	100	0	Peak

3.9 AC Conducted Emission Measurement

3.9.1 Limit of AC Conducted Emission

For equipment that is designed to be connected to the public utility (AC) power line, the radio frequency voltage that is conducted back onto the AC power line on any frequency or frequencies within the band 150 KHz to 30 MHz shall not exceed the limits in the following table.

Frequency of emission (MHz)	Conducted limit (dBuV)	
	Quasi-peak	Average
0.15-0.5	66 to 56*	56 to 46*
0.5-5	56	46
5-30	60	50

*Decreases with the logarithm of the frequency.

3.9.2 Measuring Instruments

See list of measuring instruments of this test report.

3.9.3 Test Procedures

1. The test follows the guidelines in ANSI C63.4-2003 and ANSI C63.10-2009 test site requirement.
2. The EUT was placed 0.4 meter from the conducting wall of the shielding room was kept at least 80 centimeters from any other grounded conducting surface.
3. Connect EUT to the power mains through a line impedance stabilization network (LISN).
4. All the support units are connecting to the other LISN.
5. The LISN provides 50 ohm coupling impedance for the measuring instrument.
6. The FCC states that a 50 ohm, 50 microhenry LISN should be used.
7. Both sides of AC line were checked for maximum conducted interference.
8. The frequency range from 150 KHz to 30 MHz was searched.
9. Set the test-receiver system to Peak Detect Function and specified bandwidth with Maximum Hold Mode.

3.9.4 Test Setup

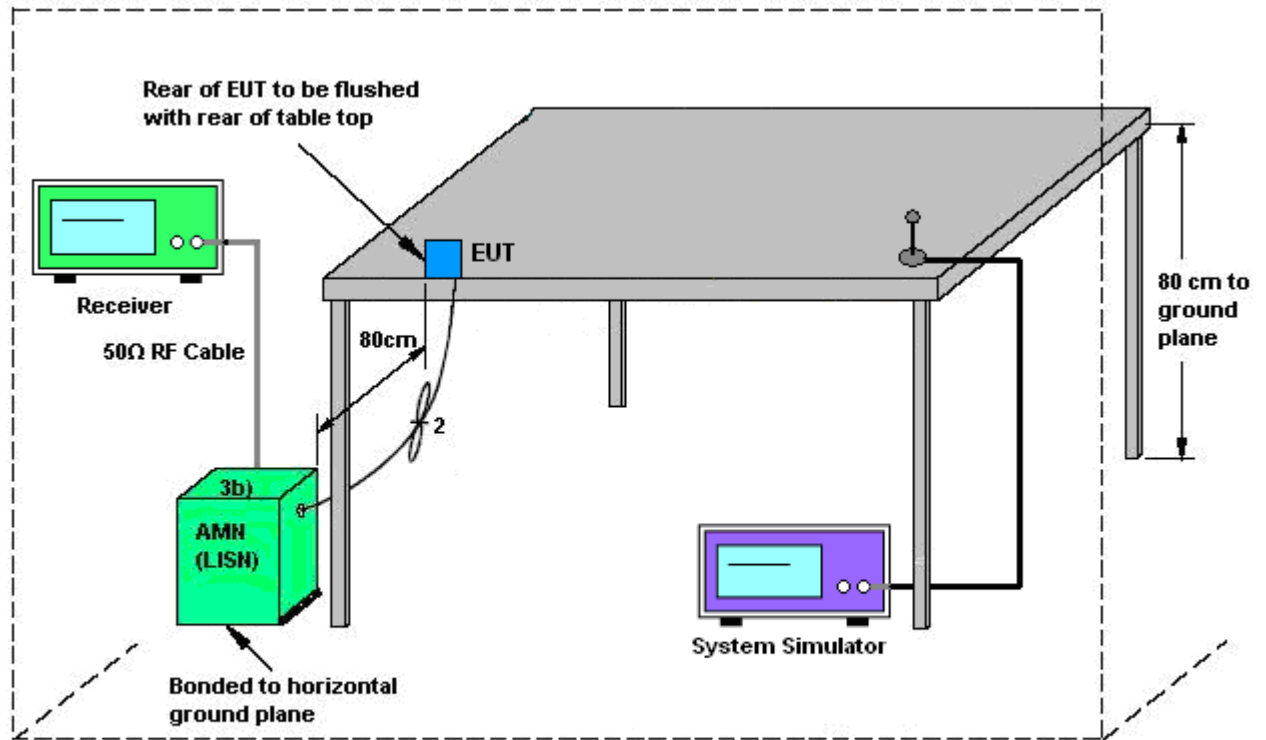

AMN = Artificial mains network (LISN)
 AE = Associated equipment
 EUT = Equipment under test
 ISN = Impedance stabilization network

3.9.5 Test Result of AC Conducted Emission

Test Mode :	Mode 1	Temperature :	20~22°C
Test Engineer :	Slash Huang	Relative Humidity :	45~47%
Test Voltage :	120Vac / 60Hz	Phase :	Line
Function Type :	Bluetooth Link + USB Cable (Charging from Notebook) + Earphone 1 + MP3		
Remark :	All emissions not reported here are more than 10 dB below the prescribed limit.		

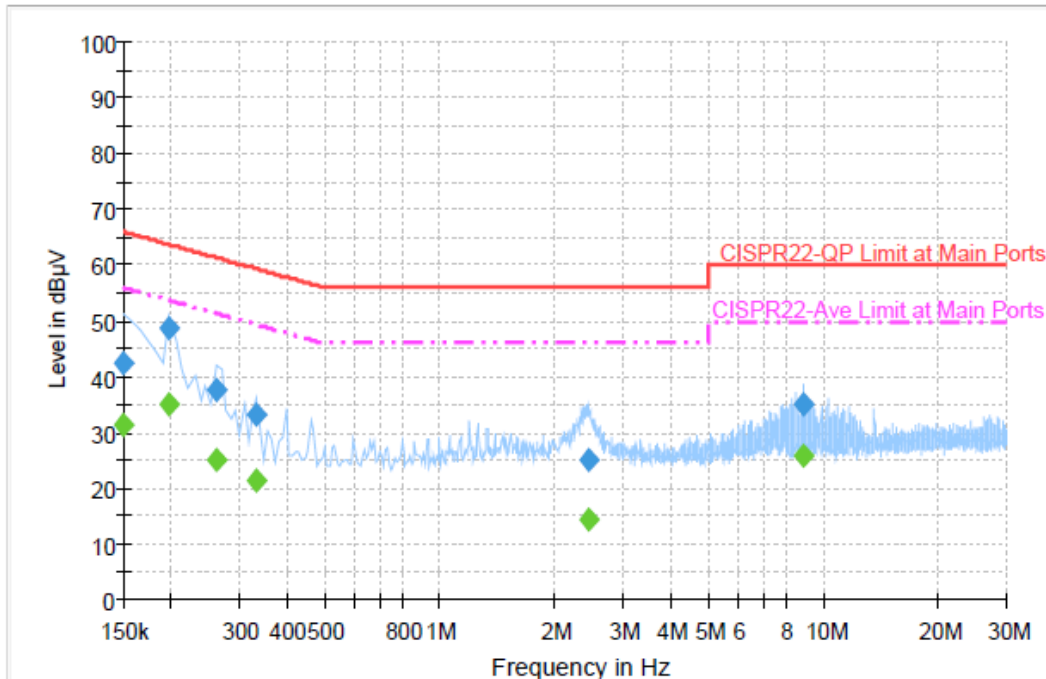

Final Result : Quasi-Peak

Frequency (MHz)	Quasi-Peak (dBµV)	Filter	Line	Corr. (dB)	Margin (dB)	Limit (dBµV)
0.150000	42.3	Off	L1	19.4	23.7	66.0
0.198000	48.6	Off	L1	19.3	15.1	63.7
0.262000	37.7	Off	L1	19.4	23.7	61.4
0.334000	33.1	Off	L1	19.4	26.3	59.4
2.438000	25.0	Off	L1	19.6	31.0	56.0
8.838000	35.0	Off	L1	19.8	25.0	60.0

Final Result : Average

Frequency (MHz)	Average (dBµV)	Filter	Line	Corr. (dB)	Margin (dB)	Limit (dBµV)
0.150000	31.3	Off	L1	19.4	24.7	56.0
0.198000	34.9	Off	L1	19.3	18.8	53.7
0.262000	25.1	Off	L1	19.4	26.3	51.4
0.334000	21.2	Off	L1	19.4	28.2	49.4
2.438000	14.2	Off	L1	19.6	31.8	46.0
8.838000	25.9	Off	L1	19.8	24.1	50.0

Test Mode :	Mode 1	Temperature :	20~22°C
Test Engineer :	Slash Huang	Relative Humidity :	45~47%
Test Voltage :	120Vac / 60Hz	Phase :	Neutral
Function Type :	Bluetooth Link + USB Cable (Charging from Notebook) + Earphone 1 + MP3		
Remark :	All emissions not reported here are more than 10 dB below the prescribed limit.		

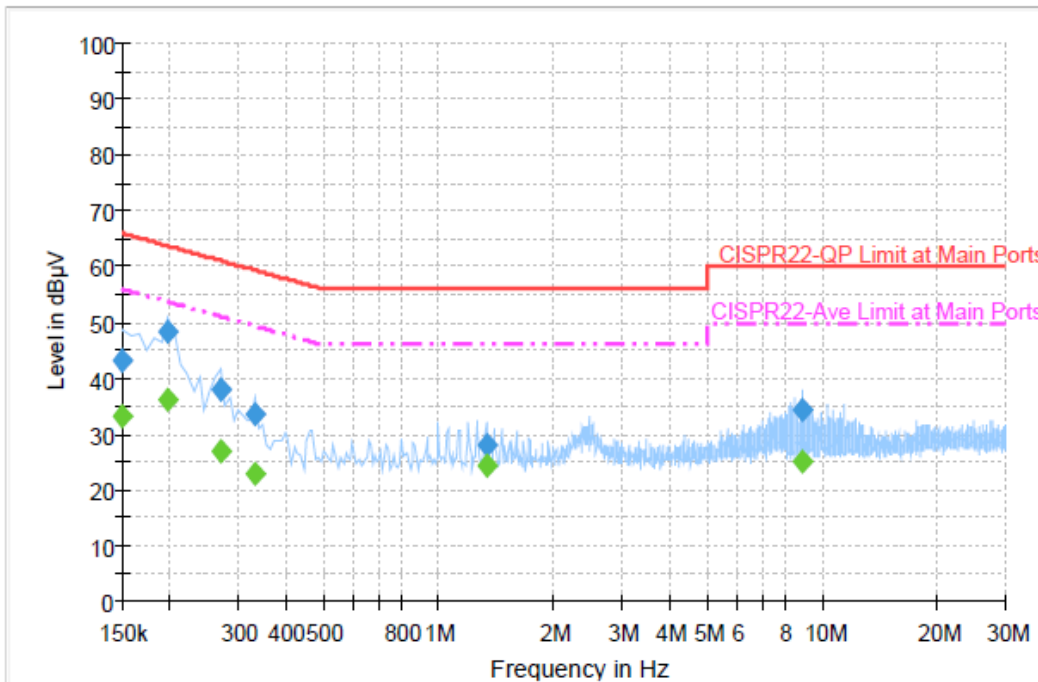

Final Result : Quasi-Peak

Frequency (MHz)	Quasi-Peak (dBµV)	Filter	Line	Corr. (dB)	Margin (dB)	Limit (dBµV)
0.150000	43.3	Off	N	19.4	22.7	66.0
0.198000	48.2	Off	N	19.3	15.5	63.7
0.270000	37.8	Off	N	19.4	23.3	61.1
0.334000	33.6	Off	N	19.4	25.8	59.4
1.334000	28.1	Off	N	19.5	27.9	56.0
8.838000	34.2	Off	N	19.8	25.8	60.0

Final Result : Average

Frequency (MHz)	Average (dBµV)	Filter	Line	Corr. (dB)	Margin (dB)	Limit (dBµV)
0.150000	33.3	Off	N	19.4	22.7	56.0
0.198000	36.2	Off	N	19.3	17.5	53.7
0.270000	26.9	Off	N	19.4	24.2	51.1
0.334000	23.0	Off	N	19.4	26.4	49.4
1.334000	24.4	Off	N	19.5	21.6	46.0
8.838000	25.2	Off	N	19.8	24.8	50.0



3.10 Antenna Requirements

3.10.1 Standard Applicable

If directional gain of transmitting antennas is greater than 6dBi, the power shall be reduced by the same level in dB comparing to gain minus 6dBi. The use of a permanently attached antenna or of an antenna that uses a unique coupling to the intentional radiator shall be considered sufficient to comply with the FCC rule.

3.10.2 Antenna Connected Construction

Non-standard connector used.

3.10.3 Antenna Gain

The antenna peak gain of EUT is less than 6 dBi. Therefore, it is not necessary to reduce maximum peak output power limit.



4 List of Measuring Equipment

Instrument	Manufacturer	Model No.	Serial No.	Characteristics	Calibration Date	Test Date	Due Date	Remark
Spectrum Analyzer	R&S	FSP40	100055	9kHz~40GHz	Jun. 06, 2012	Sep. 19, 2012 ~ Sep. 21, 2012	Jun. 05, 2013	Conducted (TH02-HY)
Bluetooth Base Station	R&S	CBT32	100519	N/A	Jun. 05, 2012	Sep. 19, 2012 ~ Sep. 21, 2012	Jun. 06, 2013	Conducted (TH02-HY)
EMI Test Receiver	R&S	ESCS 30	100356	9KHz ~ 2.75GHz	Oct. 27, 2011	Sep. 18, 2012	Oct. 26, 2012	Conduction (CO05-HY)
Two-LISN	R&S	ENV216	11-100081	9KHz ~ 30MHz	Dec. 09, 2011	Sep. 18, 2012	Dec. 08, 2012	Conduction (CO05-HY)
Two-LISN	R&S	ENV216	11-100080	9KHz ~ 30MHz	Dec. 06, 2011	Sep. 18, 2012-	Dec. 05, 2012	Conduction (CO05-HY)
AC Power Source	APC	APC-1000W	N/A	N/A	N/A	Sep. 18, 2012	N/A	Conduction (CO05-HY)
System Simulator	R&S	CMU200	117995	N/A	Jul. 28, 2011	Sep. 18, 2012	Jul. 27, 2013	Conduction (CO05-HY)
Spectrum Analyzer	Agilent	E4408B	MY44211030	9KHz ~ 26.5GHz	Nov. 23, 2011	Sep. 12, 2012 ~ Sep. 14, 2012	Nov. 22, 2012	Radiation (03CH06-HY)
Spectrum Analyzer	R&S	FSP30	101352	9KHz-30GHz	Nov. 03, 2011	Sep. 12, 2012 ~ Sep. 14, 2012	Nov. 02, 2012	Radiation (03CH06-HY)
EMI Test Receiver	R&S	ESVS10	834468/003	20MHz ~ 1000MHz	May 04, 2012	Sep. 12, 2012 ~ Sep. 14, 2012	May. 03, 2013	Radiation (03CH06-HY)
Bilog Antenna	SCHAFFNER	CBL6112B	2885	30MHz ~ 2GHz	Oct. 22, 2011	Sep. 12, 2012 ~ Sep. 14, 2012	Oct. 21, 2012	Radiation (03CH06-HY)
Double Ridge Horn Antenna	EMCO	3117	00066583	1GHz ~ 18GHz	Aug. 01, 2012	Sep. 12, 2012 ~ Sep. 14, 2012	Jul. 31, 2013	Radiation (03CH06-HY)
SHF-EHF Horn Antenna	SCHWARZBECK	BBHA 9170	BBHA9170251	15GHz ~ 40GHz	Oct. 20, 2011	Sep. 12, 2012 ~ Sep. 14, 2012	Oct. 19, 2012	Radiation (03CH06-HY)
Preamplifier	Agilent	8449B	3008A01917	1GHz ~ 26.5GHz	Apr. 13, 2012	Sep. 12, 2012 ~ Sep. 14, 2012	Apr. 12, 2013	Radiation (03CH06-HY)
Amplifier	Agilent	310N	186713	9KHz ~ 1GHz	Apr. 11, 2012	Sep. 12, 2012 ~ Sep. 14, 2012	Apr. 10, 2013	Radiation (03CH06-HY)
Pre Amplifier	EMCI	EMC051845	SN980048	1GHz ~ 18GHz	Jul. 21, 2012	Sep. 12, 2012 ~ Sep. 14, 2012	Jul. 20, 2013	Radiation (03CH06-HY)
Pre Amplifier	MITEQ	AMF-7D-00101800-30-10P	159087	1GHz~18GHz	Feb. 27, 2012	Sep. 12, 2012 ~ Sep. 14, 2012	Feb. 26, 2013	Radiation (03CH06-HY)
Loop Antenna	R&S	HFH2-Z2	860004/001	9KHz ~ 30MHz	Jul. 03, 2012	Sep. 12, 2012 ~ Sep. 14, 2012	Jul. 02, 2014	Radiation (03CH06-HY)
Bluetooth Base Station	R&S	CBT32	100522	N/A	Feb. 09, 2012	Sep. 12, 2012 ~ Sep. 14, 2012	Feb. 08, 2014	Radiation (03CH06-HY)



5 Uncertainty of Evaluation

Uncertainty of Conducted Emission Measurement (150 KHz ~ 30 MHz)

Measuring Uncertainty for a Level of Confidence of 95% ($U = 2Uc(y)$)	2.26
---	------

Uncertainty of Radiated Emission Measurement (30 MHz ~ 1000 MHz)

Measuring Uncertainty for a Level of Confidence of 95% ($U = 2Uc(y)$)	2.54
---	------

Uncertainty of Radiated Emission Measurement (1 GHz ~ 40 GHz)

Measuring Uncertainty for a Level of Confidence of 95% ($U = 2Uc(y)$)	4.72
---	------

