

## FCC Test Report

**Report No.:** RFBCBB-WTW-P20120637-6

**FCC ID:** NM82QA4100

**Test Model:** 2QA4100

**Received Date:** Dec. 18, 2020

**Test Date:** Jul. 22, 2021 ~ Oct. 06, 2021

**Issued Date:** Oct. 14, 2021

**Applicant:** HTC Corporation

**Address:** No. 88, Sec. 3, Zhongxing Rd. Xindian Dist., New Taipei City 231, Taiwan

**Issued By:** Bureau Veritas Consumer Products Services (H.K.) Ltd., Taoyuan Branch  
Lin Kou Laboratories

**Lab Address:** No. 47-2, 14th Ling, Chia Pau Vil., Lin Kou Dist., New Taipei City, Taiwan

**Test Location:** No. 19, Hwa Ya 2nd Rd., Wen Hwa Vil., Kwei Shan Dist., Taoyuan City  
33383, Taiwan

**FCC Registration /  
Designation Number:** 788550 / TW0003



This report is for your exclusive use. Any copying or replication of this report to or for any other person or entity, or use of our name or trademark, is permitted only with our prior written permission. This report sets forth our findings solely with respect to the test samples identified herein. The results set forth in this report are not indicative or representative of the quality or characteristics of the lot from which a test sample was taken or any similar or identical product unless specifically and expressly noted. Our report includes all of the tests requested by you and the results thereof based upon the information that you provided to us. You have 60 days from date of issuance of this report to notify us of any material error or omission caused by our negligence, provided, however, that such notice shall be in writing and shall specifically address the issue you wish to raise. A failure to raise such issue within the prescribed time shall constitute your unqualified acceptance of the completeness of this report, the tests conducted and the correctness of the report contents. Unless specifically mentioned, the uncertainty of measurement has been explicitly taken into account to declare the compliance or non-compliance to the specification.

## Table of Contents

<b>Release Control Record</b> .....	<b>4</b>
<b>1 Certificate of Conformity</b> .....	<b>5</b>
<b>2 Summary of Test Results</b> .....	<b>6</b>
2.1 Measurement Uncertainty.....	6
2.2 Modification Record.....	6
<b>3 General Information</b> .....	<b>7</b>
3.1 General Description of EUT.....	7
3.2 Description of Test Modes.....	9
3.2.1 Test Mode Applicability and Tested Channel Detail.....	12
3.3 Duty Cycle of Test Signal.....	17
3.4 Description of Support Units.....	18
3.4.1 Configuration of System under Test.....	18
3.5 General Description of Applied Standard.....	18
<b>4 Test Types and Results</b> .....	<b>19</b>
4.1 Radiated Emission and Bandedge Measurement.....	19
4.1.1 Limits of Radiated Emission and Bandedge Measurement.....	19
4.1.2 Test Instruments.....	20
4.1.3 Test Procedure.....	21
4.1.4 Test Setup.....	22
4.1.5 EUT Operating Condition.....	23
4.1.6 Test Results.....	24
4.2 In-Band Emission (Mask) Measurement.....	95
4.2.1 Limits of In-Band Emission (Mask) Measurement.....	95
4.2.2 Test Setup.....	95
4.2.3 Test Instruments.....	95
4.2.4 Test Procedure.....	96
4.2.5 EUT Operating Condition.....	96
4.2.6 Test Results.....	97
4.3 Conducted Emission Measurement.....	115
4.3.1 Limits of Conducted Emission Measurement.....	115
4.3.2 Test Instruments.....	115
4.3.3 Test Procedure.....	116
4.3.4 Test Setup.....	116
4.3.5 EUT Operating Condition.....	116
4.3.6 Test Results.....	117
4.4 Transmit Power Measurement.....	119
4.4.1 Limits of Transmit Power Measurement.....	119
4.4.2 Test Setup.....	119
4.4.3 Test Instruments.....	119
4.4.4 Test Procedure.....	119
4.4.5 EUT Operating Condition.....	119
4.4.6 Test Result.....	120
4.5 Emission Bandwidth Measurement.....	126
4.5.1 Test Setup.....	126
4.5.2 Test Instruments.....	126
4.5.3 Test Procedure.....	126
4.5.4 Test Results.....	127
4.6 Peak Power Spectral Density Measurement.....	141
4.6.1 Limits of Peak Power Spectral Density Measurement.....	141
4.6.2 Test Setup.....	141
4.6.3 Test Instruments.....	141
4.6.4 Test Procedure.....	141
4.6.5 EUT Operating Condition.....	141

4.6.6	Test Results .....	142
4.7	Contention Based Protocol Measurement .....	150
4.7.1	Limits of Contention Based Protocol Measurement .....	150
4.7.2	Test Setup .....	150
4.7.3	Test Instruments .....	150
4.7.4	Test Procedure .....	151
4.7.5	EUT Operating Condition .....	151
4.7.6	Test Results .....	152
4.8	Frequency Stability Measurement .....	164
4.8.1	Limits of Frequency Stability Measurement .....	164
4.8.2	Test Setup .....	164
4.8.3	Test Instruments .....	164
4.8.4	Test Procedure .....	164
4.8.5	EUT Operating Condition .....	164
4.8.6	Test Results .....	165
4.9	Operational Restrictions for 6 GHz U-NII Devices .....	166
4.9.1	Limits of Operational Restrictions for 6 GHz U-NII Devices .....	166
4.9.2	Test Setup .....	166
4.9.3	Test Instruments .....	166
4.9.4	Test Procedure .....	166
4.9.5	Test Results .....	166
<b>5</b>	<b>Pictures of Test Arrangements .....</b>	<b>167</b>
	<b>Annex A - Band-Edge Measurement .....</b>	<b>168</b>
	<b>Appendix A- Information of the Testing Laboratories .....</b>	<b>182</b>

### Release Control Record

Issue No.	Description	Date Issued
RFBCBB-WTW-P20120637-6	Original Release	Oct. 14, 2021

## 1 Certificate of Conformity

**Product:** Headset

**Brand:** VIVE

**Test Model:** 2QA4100

**Sample Status:** Identical Prototype

**Applicant:** HTC Corporation

**Test Date:** Jul. 22. 2021 ~ Oct. 06, 2021

**Standard:** 47 CFR FCC Part 15, Subpart E (Section 15.407)  
ANSI C63.10: 2013

The above equipment has been tested by **Bureau Veritas Consumer Products Services (H.K.) Ltd., Taoyuan Branch**, and found compliance with the requirement of the above standards. The test record, data evaluation & Equipment Under Test (EUT) configurations represented herein are true and accurate accounts of the measurements of the sample's RF characteristics under the conditions specified in this report.

**Prepared by :** , **Date:** Oct. 14, 2021  
Vera Huang / Specialist

**Approved by :** , **Date:** Oct. 14, 2021  
Dylan Chiou / Senior Engineer

## 2 Summary of Test Results

47 CFR FCC Part 15, Subpart E (Section 15.407)			
FCC Clause	Test Item	Result	Remarks
15.407(b)(9)	AC Power Conducted Emissions	Pass	Meet the requirement of limit. Minimum passing margin is -12.74dB at 11.31400MHz.
15.407(b)(6)(9)	Radiated Emissions	Pass	Meet the requirement of limit. Minimum passing margin is -0.3dB at 7125.00MHz.
15.407(b)(7)	In-Band Emission (Mask)	Pass	Meet the requirement of limit.
15.407(a)(8)	Max Average Transmit Power	Pass	Meet the requirement of limit.
15.407(a)(10)	Emission Bandwidth Measurement	Pass	Meet the requirement of limit.
15.407(a)(8)	Peak Power Spectral Density	Pass	Meet the requirement of limit.
15.407 (d)(6)	Contention-based Protocol.	Pass	Meet the requirement of limit.
15.407(g)	Frequency Stability	Pass	Meet the requirement of limit.
15.407(d)(5)	Operational restrictions for 6 GHz U-NII devices	Pass	Declaration by applicant
15.203	Antenna Requirement	Pass	No antenna connector is used.

### Note:

Determining compliance based on the results of the compliance measurement, not taking into account measurement instrumentation uncertainty.

### 2.1 Measurement Uncertainty

Where relevant, the following measurement uncertainty levels have been estimated for tests performed on the EUT as specified in CISPR 16-4-2:

Measurement	Frequency	Expanded Uncertainty (k=2) (±)
Conducted Emissions at mains ports	150kHz ~ 30MHz	2.79 dB
Radiated Emissions up to 1 GHz	9kHz ~ 30MHz	3.04 dB
	30MHz ~ 200MHz	3.63 dB
	200MHz ~1000MHz	3.64 dB
Radiated Emissions above 1 GHz	1GHz ~ 18GHz	2.29 dB
	18GHz ~ 40GHz	2.29 dB

### 2.2 Modification Record

There were no modifications required for compliance.

### 3 General Information

#### 3.1 General Description of EUT

Product	Headset
Brand	VIVE
Test Model	2QA4100
Status of EUT	Identical Prototype
Power Supply Rating	11 Vdc (Battery) 12 Vdc (Adapter)
Modulation Type	64QAM, 16QAM, QPSK, BPSK for OFDM 1024QAM, 256QAM, 64QAM, 16QAM, QPSK, BPSK for OFDMA
Modulation Technology	OFDM, OFDMA
Transfer Rate	802.11a: up to 54 Mbps 802.11ax: up to 2401.9 Mbps
Operating Frequency	5.955 ~ 6.415GHz, 6.435 ~ 6.525GHz, 6.525 ~ 6.875GHz, 6.875 ~ 7.115GHz
Number of Channel	802.11a/ax (HE20): 59 802.11ax (HE40): 29 802.11ax (HE80): 14 802.11ax (HE160): 7
Output Power	<b>5.955 ~ 6.415GHz:</b> 42.269 mW (EIRP: 18.26 dBm / 66.988 mW) <b>6.435 ~ 6.525GHz:</b> 47.163 mW (EIRP: 18.24 dBm / 66.681 mW) <b>6.525 ~ 6.875GHz:</b> 48.476 mW (EIRP: 18.36 dBm / 68.549 mW) <b>6.875 ~ 7.115GHz:</b> 48.785 mW (EIRP: 17.88 dBm / 61.376 mW)
Antenna Type	Refer to Note as below
Antenna Connector	N/A
Accessory Device	Refer to Note as below
Data Cable Supplied	Refer to Note as below

Note:

1. The EUT incorporates a MIMO function:

6GHz Band		
Modulation Mode	TX & RX Configuration	
802.11a	2TX	2RX
802.11ax (HE20)	2TX	2RX
802.11ax (HE40)	2TX	2RX
802.11ax (HE80)	2TX	2RX
802.11ax (HE160)	2TX	2RX
802.11ax (RU26/52/106/242/484/996/996*2)	2TX	2RX

Note: For Partial RU, after pre-tested, only the worse cases were chosen for final test and presented in the test report. (Final test mode refer section 3.2.1)

2. The antenna information is listed as below.

Ant. Type	Ant.	Antenna gain (dBi)			
		5925-6425MHz	6425-6525MHz	6525-6875MHz	6875-7125MHz
Dipole	Main	2	1.5	1.5	1
	Aux.	2	1.5	1.5	1

3. The above EUT information is declared by manufacturer and for more detailed features description, please refers to the manufacturer's specifications or user's manual.
4. The above Antenna information is declared by manufacturer and for more detailed features description, please refer to the manufacturer's specifications, the laboratory shall not be held responsible.



### 3.2 Description of Test Modes

#### FOR 5925 ~ 6425MHz (U-NII-5 band)

24 channels are provided for 802.11a, 802.11ax (HE20):

Channel	Frequency	Channel	Frequency	Channel	Frequency	Channel	Frequency
1	5955 MHz	5	5975 MHz	9	5995 MHz	13	6015 MHz
17	6035 MHz	21	6055 MHz	25	6075 MHz	29	6095 MHz
33	6115 MHz	37	6135 MHz	41	6155 MHz	45	6175 MHz
49	6195 MHz	53	6215 MHz	57	6235 MHz	61	6255 MHz
65	6275 MHz	69	6295 MHz	73	6315 MHz	77	6335 MHz
81	6355 MHz	85	6375 MHz	89	6395 MHz	93	6415 MHz

12 channels are provided for 802.11ax (HE40):

Channel	Frequency	Channel	Frequency	Channel	Frequency	Channel	Frequency
3	5965 MHz	11	6005 MHz	19	6045 MHz	27	6085 MHz
35	6125 MHz	43	6165 MHz	51	6205 MHz	59	6245 MHz
67	6285 MHz	75	6325 MHz	83	6365 MHz	91	6405 MHz

6 channel is provided for 802.11ax (HE80):

Channel	Frequency	Channel	Frequency	Channel	Frequency	Channel	Frequency
7	5985 MHz	23	6065 MHz	39	6145 MHz	55	6225 MHz
71	6305 MHz	87	6385 MHz				

3 channels are provided for 802.11ax (HE160):

Channel	Frequency	Channel	Frequency	Channel	Frequency
15	6025 MHz	47	6185 MHz	79	6345 MHz

### FOR 6425 ~ 6525MHz (U-NII-6 band)

5 channels are provided for 802.11a, 802.11ax (HE20):

Channel	Frequency	Channel	Frequency	Channel	Frequency	Channel	Frequency
97	6435 MHz	101	6455 MHz	105	6475 MHz	109	6495 MHz
113	6515 MHz						

3 channels are provided for 802.11ax (HE40):

Channel	Frequency	Channel	Frequency	Channel	Frequency
99	6445 MHz	107	6485 MHz	*115	6525 MHz

2 channel are provided for 802.11ax (HE80):

Channel	Frequency	Channel	Frequency
103	6465 MHz	*119	6545 MHz

1 channel is provided for 802.11ax (HE160):

Channel	Frequency
*111	6505 MHz

### FOR 6525 ~ 6875MHz (U-NII-7 band)

18 channels are provided for 802.11a, 802.11ax (HE20):

Channel	Frequency	Channel	Frequency	Channel	Frequency	Channel	Frequency
117	6535 MHz	121	6555 MHz	125	6575 MHz	129	6595 MHz
133	6615 MHz	137	6635 MHz	141	6655 MHz	145	6675 MHz
149	6695 MHz	153	6715 MHz	157	6735 MHz	161	6755 MHz
165	6775 MHz	169	6795 MHz	173	6815 MHz	177	6835 MHz
181	6855 MHz	*185	6875 MHz				

9 channels are provided for 802.11ax (HE40):

Channel	Frequency	Channel	Frequency	Channel	Frequency	Channel	Frequency
123	6565 MHz	131	6605 MHz	139	6645 MHz	147	6685 MHz
155	6725 MHz	163	6765 MHz	171	6805 MHz	179	6845 MHz
*187	6885 MHz						

4 channels are provided for 802.11ax (HE80):

Channel	Frequency	Channel	Frequency	Channel	Frequency	Channel	Frequency
135	6625 MHz	151	6705 MHz	167	6785 MHz	*183	6865 MHz

2 channels are provided for 802.11ax (HE160):

Channel	Frequency	Channel	Frequency
143	6665 MHz	*175	6825 MHz

**FOR 6875 ~ 7125MHz (U-NII-8 band):**

12 channels are provided for 802.11a, 802.11ax (HE20):

Channel	Frequency	Channel	Frequency	Channel	Frequency	Channel	Frequency
189	6895 MHz	193	6915 MHz	197	6935 MHz	201	6955 MHz
205	6975 MHz	209	6995 MHz	213	7015 MHz	217	7035 MHz
221	7055 MHz	225	7075 MHz	229	7095 MHz	233	7115 MHz

5 channels are provided for 802.11ax (HE40):

Channel	Frequency	Channel	Frequency	Channel	Frequency
195	6925 MHz	203	6965 MHz	211	7005 MHz
219	7045 MHz	227	7085 MHz		

2 channel is provided for 802.11ax (HE80):

Channel	Frequency	Channel	Frequency
199	6945 MHz	215	7025 MHz

1 channel is provided for 802.11ax (HE160):

Channel	Frequency
207	6985 MHz

Note: \* mean this's straddle channel.

### 3.2.1 Test Mode Applicability and Tested Channel Detail

EUT Configure Mode	Applicable To						Description
	RE $\geq$ 1G	RE<1G	IBE	PLC	CBP	APCM	
-	√	√	√	√	√	√	-

Where **RE $\geq$ 1G**: Radiated Emission above 1GHz

**RE<1G**: Radiated Emission below 1GHz

**PLC**: Power Line Conducted Emission

**APCM**: Antenna Port Conducted Measurement

**IBE**: In-Band Emission (MASK)

**CBP**:Contention Based Protocol

Note: The EUT had been pre-tested on the positioned of each 3 axis. The worst case was found when positioned on Y-plane

#### **Radiated Emission Measurement (Above 1GHz):**

Pre-Scan has been conducted to determine the worst-case mode from all possible combinations between available modulations, data rates, RU configurations and antenna ports (if EUT with antenna diversity architecture).

Following channel(s) was (were) selected for the final test as listed below.

Mode	FREQ. Band (MHz)	Available Channel	Tested Channel	Modulation Technology	Modulation Type	Data Rate Parameter
802.11a	5955-6415	1 to 93	1, 45, 93	OFDM	BPSK	6Mb/s
	6435-6525	97 to 113	97, 105, 113	OFDM	BPSK	6Mb/s
	6525-6855	117 to 185	117, 149, 181, 185	OFDM	BPSK	6Mb/s
	6895-7115	189 to 233	209, 233	OFDM	BPSK	6Mb/s
802.11ax (HE20)	5955-6415	1 to 93	1, 45, 93	OFDMA	BPSK	MCS0
	6435-6525	97 to 113	97, 105, 113	OFDMA	BPSK	MCS0
	6525-6855	117 to 185	117, 149, 181, 185	OFDMA	BPSK	MCS0
	6895-7115	189 to 233	209, 229, 233	OFDMA	BPSK	MCS0
802.11ax (HE40)	5955-6415	3 to 91	3, 43, 91	OFDMA	BPSK	MCS0
	6435-6525	99 to 115	99, 107, 115	OFDMA	BPSK	MCS0
	6525-6855	123 to 187	123, 155, 179, 187	OFDMA	BPSK	MCS0
	6925-7085	195 to 227	211, 227	OFDMA	BPSK	MCS0
802.11ax (HE80)	5955-6415	7 to 87	7, 39, 87	OFDMA	BPSK	MCS0
	6435-6525	103 to 119	103, 119	OFDMA	BPSK	MCS0
	6525-6855	135 to 183	135, 151, 167, 183	OFDMA	BPSK	MCS0
	6945-7025	199 to 215	199, 215	OFDMA	BPSK	MCS0
802.11ax (HE160)	5955-6415	15 to 79	15, 47, 79	OFDMA	BPSK	MCS0
	6435-6525	111	111	OFDMA	BPSK	MCS0
	6525-6855	143 to 175	143, 175	OFDMA	BPSK	MCS0
	6875-7115	207	207	OFDMA	BPSK	MCS0

Preamble (MHz)	RU Config.	FREQ. Band (MHz)	Available Channel	Tested Channel	Modulation Technology	Modulation Type	Data Rate Parameter
20	26/0 52/37 106/53 242	5955-6415	1 to 93	1	OFDMA	BPSK	MCS0
	26/8 52/40 106/54 242	6895-7115	189 to 233	233	OFDMA	BPSK	MCS0
40	484	5955-6415	3 to 91	3	OFDMA	BPSK	MCS0
		6925-7085	195 to 227	227	OFDMA	BPSK	MCS0
80	996	5955-6415	7 to 87	7	OFDMA	BPSK	MCS0
		6875-7115	199 to 215	215	OFDMA	BPSK	MCS0
160	996*2	5955-6415	15 to 79	15	OFDMA	BPSK	MCS0
		6875-7115	207	207	OFDMA	BPSK	MCS0

#### **Radiated Emission Measurement (Below 1GHz):**

- Pre-Scan has been conducted to determine the worst-case mode from all possible combinations between available modulations, data rates, RU configurations and antenna ports (if EUT with antenna diversity architecture).
- Following channel(s) was (were) selected for the final test as listed below.

Mode	FREQ. Band (MHz)	Available Channel	Tested Channel	Modulation Technology	Modulation Type	Data Rate Parameter
802.11ax (HE160)	5955-6415	15 to 79	207	OFDMA	BPSK	MCS0
	6435-6525	111				
	6525-6855	143 to 175				
	6875-7115	207				

### In-Band Emission (MASK) Measurement:

- Pre-Scan has been conducted to determine the worst-case mode from all possible combinations between available modulations, data rates, RU configurations and antenna ports (if EUT with antenna diversity architecture).
- Following channel(s) was (were) selected for the final test as listed below.

Mode	FREQ. Band (MHz)	Available Channel	Tested Channel	Modulation Technology	Modulation Type	Data Rate Parameter
802.11a	5955-6415	1 to 93	1, 45, 93	OFDM	BPSK	6Mb/s
	6435-6525	97 to 113	97, 105, 113	OFDM	BPSK	6Mb/s
	6525-6855	117 to 185	117, 149, 181, 185	OFDM	BPSK	6Mb/s
	6895-7115	189 to 233	209, 233	OFDM	BPSK	6Mb/s
802.11ax (HE20)	5955-6415	1 to 93	1, 45, 93	OFDMA	BPSK	MCS0
	6435-6525	97 to 113	97, 105, 113	OFDMA	BPSK	MCS0
	6525-6855	117 to 185	117, 149, 181, 185	OFDMA	BPSK	MCS0
	6895-7115	189 to 233	209, 233	OFDMA	BPSK	MCS0
802.11ax (HE40)	5955-6415	3 to 91	3, 43, 91	OFDMA	BPSK	MCS0
	6435-6525	99 to 115	99, 107, 115	OFDMA	BPSK	MCS0
	6525-6855	123 to 187	123, 155, 179, 187	OFDMA	BPSK	MCS0
	6925-7085	195 to 227	211, 227	OFDMA	BPSK	MCS0
802.11ax (HE80)	5955-6415	7 to 87	7, 39, 87	OFDMA	BPSK	MCS0
	6435-6525	103 to 119	103, 119	OFDMA	BPSK	MCS0
	6525-6855	135 to 183	151, 183	OFDMA	BPSK	MCS0
	6945-7025	199 to 215	199, 215	OFDMA	BPSK	MCS0
802.11ax (HE160)	5955-6415	15 to 79	15, 47, 79	OFDMA	BPSK	MCS0
	6435-6525	111	111	OFDMA	BPSK	MCS0
	6525-6855	143 to 175	143, 175	OFDMA	BPSK	MCS0
	6875-7115	207	207	OFDMA	BPSK	MCS0

### Power Line Conducted Emission Measurement:

- Pre-Scan has been conducted to determine the worst-case mode from all possible combinations between available modulations, data rates, RU configurations and antenna ports (if EUT with antenna diversity architecture).
- Following channel(s) was (were) selected for the final test as listed below.

Mode	FREQ. Band (MHz)	Available Channel	Tested Channel	Modulation Technology	Modulation Type	Data Rate Parameter
802.11ax (HE160)	5955-6415	15 to 79	207	OFDMA	BPSK	MCS0
	6435-6525	111				
	6525-6855	143 to 175				
	6875-7115	207				

### Antenna Port Conducted Measurement:

- This item includes all test value of each mode, but only includes spectrum plot of worst value of each mode.
- Pre-Scan has been conducted to determine the worst-case mode from all possible combinations between available modulations, data rates, RU configurations and antenna ports (if EUT with antenna diversity architecture).
- Following channel(s) was (were) selected for the final test as listed below.

Mode	FREQ. Band (MHz)	Available Channel	Tested Channel	Modulation Technology	Modulation Type	Data Rate Parameter
802.11a	5955-6415	1 to 93	1, 45, 93	OFDM	BPSK	6Mb/s
	6435-6525	97 to 113	97, 105, 113	OFDM	BPSK	6Mb/s
	6525-6855	117 to 185	117, 149, 181, 185	OFDM	BPSK	6Mb/s
	6895-7115	189 to 233	209, 233	OFDM	BPSK	6Mb/s
802.11ax (HE20)	5955-6415	1 to 93	1, 45, 93	OFDMA	BPSK	MCS0
	6435-6525	97 to 113	97, 105, 113	OFDMA	BPSK	MCS0
	6525-6855	117 to 185	117, 149, 181, 185	OFDMA	BPSK	MCS0
	6895-7115	189 to 233	209, 233	OFDMA	BPSK	MCS0
802.11ax (HE40)	5955-6415	3 to 91	3, 43, 91	OFDMA	BPSK	MCS0
	6435-6525	99 to 115	99, 107, 115	OFDMA	BPSK	MCS0
	6525-6855	123 to 187	123, 155, 179, 187	OFDMA	BPSK	MCS0
	6925-7085	195 to 227	211, 227	OFDMA	BPSK	MCS0
802.11ax (HE80)	5955-6415	7 to 87	7, 39, 87	OFDMA	BPSK	MCS0
	6435-6525	103 to 119	103, 119	OFDMA	BPSK	MCS0
	6525-6855	135 to 183	151, 183	OFDMA	BPSK	MCS0
	6945-7025	199 to 215	199, 215	OFDMA	BPSK	MCS0
802.11ax (HE160)	5955-6415	15 to 79	15, 47, 79	OFDMA	BPSK	MCS0
	6435-6525	111	111	OFDMA	BPSK	MCS0
	6525-6855	143 to 175	143, 175	OFDMA	BPSK	MCS0
	6875-7115	207	207	OFDMA	BPSK	MCS0

Preamble (MHz)	RU Config.	FREQ. Band (MHz)	Available Channel	Tested Channel	Modulation Technology	Modulation Type	Data Rate Parameter
20	26/52/ 106/242	5955-6415	1 to 93	1, 45, 93	OFDMA	BPSK	MCS0
		6435-6525	97 to 113	97, 105, 113	OFDMA	BPSK	MCS0
		6525-6855	117 to 185	117, 149, 181, 185	OFDMA	BPSK	MCS0
		6895-7115	189 to 233	209, 233	OFDMA	BPSK	MCS0
40	484	5955-6415	3 to 91	3, 43, 91	OFDMA	BPSK	MCS0
		6435-6525	99 to 115	99, 107, 115	OFDMA	BPSK	MCS0
		6525-6855	123 to 187	123, 155, 179, 187	OFDMA	BPSK	MCS0
		6925-7085	195 to 227	211, 227	OFDMA	BPSK	MCS0
80	996	5955-6415	7 to 87	7, 39, 87	OFDMA	BPSK	MCS0
		6435-6525	103 to 119	103, 119	OFDMA	BPSK	MCS0
		6525-6855	135 to 183	151, 183	OFDMA	BPSK	MCS0
		6875-7115	199 to 215	199, 215	OFDMA	BPSK	MCS0
160	996*2	5955-6415	15 to 79	15, 47, 79	OFDMA	BPSK	MCS0
		6435-6525	111	111	OFDMA	BPSK	MCS0
		6525-6855	143 to 175	143, 175	OFDMA	BPSK	MCS0
		6875-7115	207	207	OFDMA	BPSK	MCS0

**Contention Based Protocol Measurement:**

- Pre-Scan has been conducted to determine the worst-case mode from all possible combinations between available modulations, data rates and antenna ports (if EUT with antenna diversity architecture).
- Following channel(s) was (were) selected for the final test as listed below.

Mode	FREQ. Band (MHz)	Available Channel	Tested Channel	Modulation Technology	Modulation Type	Data Rate Parameter
802.11ax (HE20)	5955-6415	1 to 93	37	OFDMA	BPSK	MCS0
	6435-6525	97 to 113	101	OFDMA	BPSK	MCS0
	6525-6855	117 to 185	149	OFDMA	BPSK	MCS0
	6895-7115	189 to 233	213	OFDMA	BPSK	MCS0
802.11ax (HE160)	5955-6415	15 to 79	47	OFDMA	BPSK	MCS0
	6435-6525	111	111	OFDMA	BPSK	MCS0
	6525-6855	143 to 175	143	OFDMA	BPSK	MCS0
	6875-7115	207	207	OFDMA	BPSK	MCS0

**Test Condition:**

Applicable To	Environmental Conditions	Input Power (System)	Tested By
RE $\geq$ 1G	21deg. C, 67%RH	120Vac, 60Hz	Raymond Lee, Edison Lee
RE<1G	22deg. C, 68%RH	120Vac, 60Hz	Edison Lee
PLC	25deg. C, 75%RH	120Vac, 60Hz	Rex Wang
APCM	25deg. C, 60%RH	11 Vdc	Wayne Lin



### 3.3 Duty Cycle of Test Signal

**802.11a:** Duty cycle = 2.093 ms/2.113 ms= 0.991, Duty cycle of test signal is  $\geq 98\%$ , duty factor is not required.

**802.11ax (HE20)/RU 26/RU 52/RU 106/RU 242:** Duty cycle = 5.441 ms/5.471 ms= 0.995, Duty cycle of test signal is  $\geq 98\%$ , duty factor is not required.

**802.11ax (HE40)/RU 484:** Duty cycle = 5.438 ms/5.468 ms= 0.995, Duty cycle of test signal is  $\geq 98\%$ , duty factor is not required.

**802.11ax (HE80)/RU996:** Duty cycle = 5.453 ms/5.494 ms= 0.993, Duty cycle of test signal is  $\geq 98\%$ , duty factor is not required.

**802.11ax (HE160)/RU996\*2:** Duty cycle = 5.435 ms/5.480 ms= 0.992, Duty cycle of test signal is  $\geq 98\%$ , duty factor is not required.



### 3.4 Description of Support Units

The EUT has been tested as an independent unit together with other necessary accessories or support units. The following support units or accessories were used to form a representative test configuration during the tests.

ID	Cable Descriptions	Qty.	Length (m)	Shielding (Yes/No)	Cores (Qty.)	Remarks
1.	Type C Cable	2	1.15	Y	0	Provided by client

Note:

1. All power cords of the above support units are non-shielded (1.8m).

#### 3.4.1 Configuration of System under Test

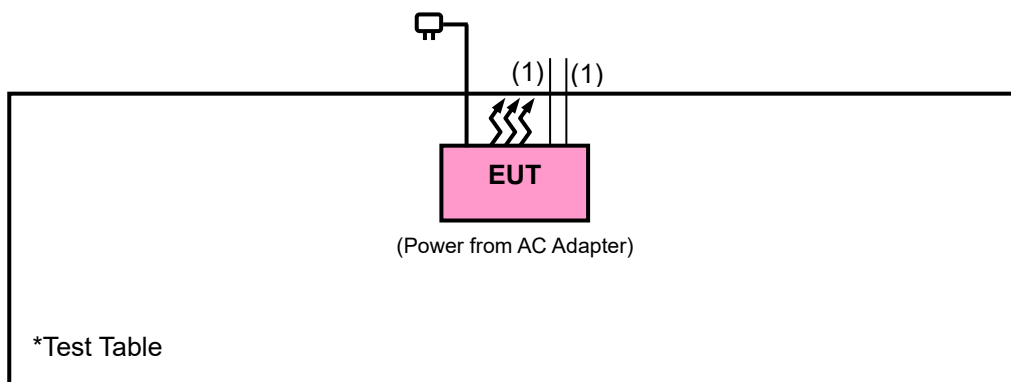

### 3.5 General Description of Applied Standard

The EUT is a RF Product. According to the specifications of the manufacturer, it must comply with the requirements of the following standards and references:

#### Test Standard:

**FCC Part 15, Subpart E (15.407)**

**ANSI C63.10-2013**

All test items have been performed and recorded as per the above standards.

#### References Test Guidance:

**KDB 987594 D02 EMC Measurement v01r01**

**KDB 789033 D02 General UNII Test Procedure New Rules v02r01**

**KDB 662911 D01 Multiple Transmitter Output v02r01**

All test items have been performed as a reference to the above KDB test guidance.

## 4 Test Types and Results

### 4.1 Radiated Emission and Bandedge Measurement

#### 4.1.1 Limits of Radiated Emission and Bandedge Measurement

Radiated emissions which fall in the restricted bands must comply with the radiated emission limits specified as below table.

Frequencies (MHz)	Field Strength (microvolts/meter)	Measurement Distance (meters)
0.009 ~ 0.490	2400/F(kHz)	300
0.490 ~ 1.705	24000/F(kHz)	30
1.705 ~ 30.0	30	30
30 ~ 88	100	3
88 ~ 216	150	3
216 ~ 960	200	3
Above 960	500	3

**NOTE:**

1. The lower limit shall apply at the transition frequencies.
2. Emission level (dBuV/m) = 20 log Emission level (uV/m).
3. For frequencies above 1000MHz, the field strength limits are based on average detector, however, the peak field strength of any emission shall not exceed the maximum permitted average limits, specified above by more than 20dB under any condition of modulation.

Limits of unwanted emission out of the restricted bands

Frequencies (MHz)	EIRP Limit	Equivalent Field Strength at 3m
5925MHz > F > 7125MHz	Peak:-7 (dBm/MHz)	88.2(dBµV/m)
	Average: -27 (dBm/MHz)	68.2(dBµV/m)

**Note:**

The following formula is used to convert the equipment isotropic radiated power (eirp) to field strength:

$$E = \frac{1000000\sqrt{30P}}{3} \mu\text{V/m, where P is the eirp (Watts).}$$

## 4.1.2 Test Instruments

Description & Manufacturer	Model No.	Serial No.	Date of Calibration	Due Date of Calibration
Test Receiver KEYSIGHT	N9038A	MY55420137	Apr. 09, 2021	Apr. 08, 2022
Spectrum Analyzer ROHDE & SCHWARZ	FSP40	100039	Jun. 10, 2021	Jun. 09, 2022
BILOG Antenna SCHWARZBECK	VULB9168	9168-160	Nov. 06, 2020	Nov. 05, 2021
HORN Antenna SCHWARZBECK	BBHA 9120 D	9120D-1169	Nov. 22, 2020	Nov. 21, 2021
HORN Antenna SCHWARZBECK	BBHA 9170	BBHA9170241	Nov. 22, 2020	Nov. 21, 2021
Preamplifier Agilent (Below 1GHz)	8447D	2944A10638	Jun. 05, 2021	Jun. 04, 2022
Preamplifier Agilent (Above 1GHz)	8449B	3008A02367	Feb. 17, 2021	Feb. 16, 2022
RF signal cable HUBER+SUHNER&EMCI	SUCOFLEX 104 & EMC104-SM- SM8000	CABLE-CH9-02 (248780+171006)	Jan. 16, 2021	Jan. 15, 2022
RF signal cable HUBER+SUHNER	SUCOFLEX 104	CABLE-CH9- (250795/4)	Jan. 16, 2021	Jan. 15, 2022
RF signal cable Woken	8D-FB	Cable-CH9-01	Jun. 05, 2021	Jun. 04, 2022
Software BV ADT	ADT_Radiated_ V7.6.15.9.5	NA	NA	NA
Antenna Tower EMCO	2070/2080	512.835.4684	NA	NA
Turn Table EMCO	2087-2.03	NA	NA	NA
Antenna Tower & Turn BV ADT	AT100	AT93021705	NA	NA
Turn Table BV ADT	TT100	TT93021705	NA	NA
Turn Table Controller BV ADT	SC100	SC93021705	NA	NA
Pre-amplifier (18GHz- 40GHz) EMC	EMC184045B	980175	Sep. 04, 2020	Sep. 03, 2021
			Sep. 04, 2021	Sep. 03, 2022
Boresight Antenna Fixture	FBA-01	FBA-SIP01	NA	NA
USB Wideband Power Sensor KEYSIGHT	U2021XA	MY55050005/MY55 190004/MY551900 07/MY55210005	Jul. 12, 2021	Jul. 11, 2022
DC source IDRC	DSP-030-025HD	500158	Jul. 08, 2021	Jul. 07, 2022
Temperature chamber WIT	TH-4S-C	W981030	Jun. 01, 2021	May 31, 2022

Note: 1. The calibration interval of the above test instruments is 12 months and the calibrations are traceable to NML/ROC and NIST/USA.

2. The test was performed in HwaYa Chamber 9.

#### 4.1.3 Test Procedure

##### **For Radiated emission below 30MHz**

- a. The EUT was placed on the top of a rotating table 0.8 meters above the ground at a 3 meter chamber room. The table was rotated 360 degrees to determine the position of the highest radiation.
- b. The EUT was set 3 meters away from the interference-receiving antenna, which was mounted on the top of a variable-height antenna tower.
- c. Parallel, perpendicular, and ground-parallel orientations of the antenna are set to make the measurement.
- d. For each suspected emission, the EUT was arranged to its worst case and the rotatable table was turned from 0 degrees to 360 degrees to find the maximum reading.
- e. The test-receiver system was set to Quasi-Peak Detect Function and Specified Bandwidth with Maximum Hold Mode.

##### **NOTE:**

1. The resolution bandwidth and video bandwidth of test receiver/spectrum analyzer is 9kHz at frequency below 30MHz.

##### **For Radiated emission above 30MHz**

- a. The EUT was placed on the top of a rotating table 0.8 meters (for 30MHz ~ 1GHz) / 1.5 meters (for above 1GHz) above the ground at 3 meter chamber room for test. The table was rotated 360 degrees to determine the position of the highest radiation.
- b. The EUT was set 3 meters away from the interference-receiving antenna, which was mounted on the top of a variable-height antenna tower.
- c. The height of antenna is varied from one meter to four meters above the ground to determine the maximum value of the field strength. Both horizontal and vertical polarizations of the antenna are set to make the measurement.
- d. For each suspected emission, the EUT was arranged to its worst case and then the antenna was tuned to heights from 1 meter to 4 meters and the rotatable table was turned from 0 degrees to 360 degrees to find the maximum reading.
- e. The test-receiver system was set to quasi-peak detect function and specified bandwidth with maximum hold mode when the test frequency is below 1 GHz.
- f. The test-receiver system was set to peak detects function and specified bandwidth with maximum hold mode when the test frequency is above 1 GHz. If the peak reading value also meets average limit, measurement with the RMS detector is unnecessary.

##### **Note:**

1. The resolution bandwidth and video bandwidth of test receiver/spectrum analyzer is 120kHz for Quasi-peak detection (QP) at frequency below 1GHz.
2. The resolution bandwidth of test receiver/spectrum analyzer is 1 MHz and the video bandwidth is 3 MHz for Peak detection (PK) at frequency above 1GHz.
3. The detection is peak and the resolution bandwidth of test receiver/spectrum analyzer is 1MHz and the video bandwidth is  $\geq 1/T$  (Duty cycle  $< 98\%$ ) or 10Hz (Duty cycle  $\geq 98\%$ ) for Average measurement (AV) at frequency above 1GHz.
4. All modes of operation were investigated and the worst-case emissions are reported.

#### 4.1.4 Test Setup

##### For Radiated emission below 30MHz

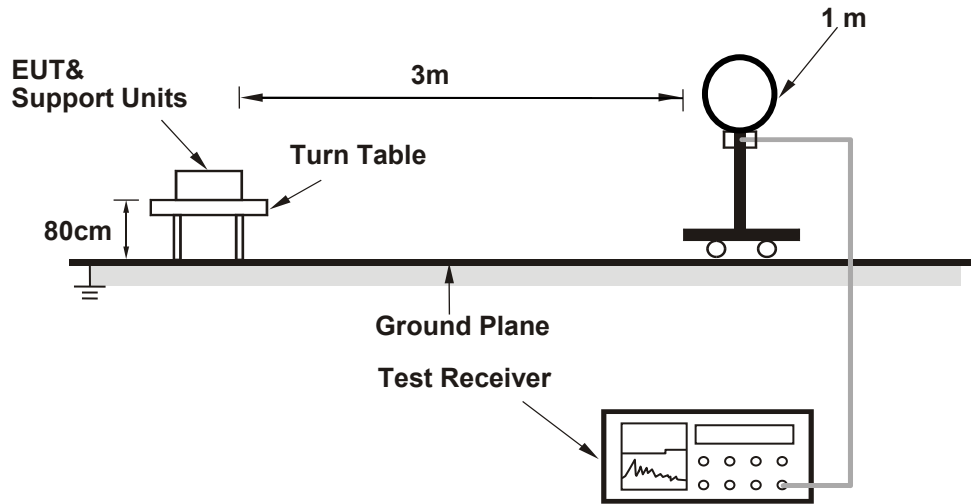

##### For Radiated emission 30MHz to 1GHz

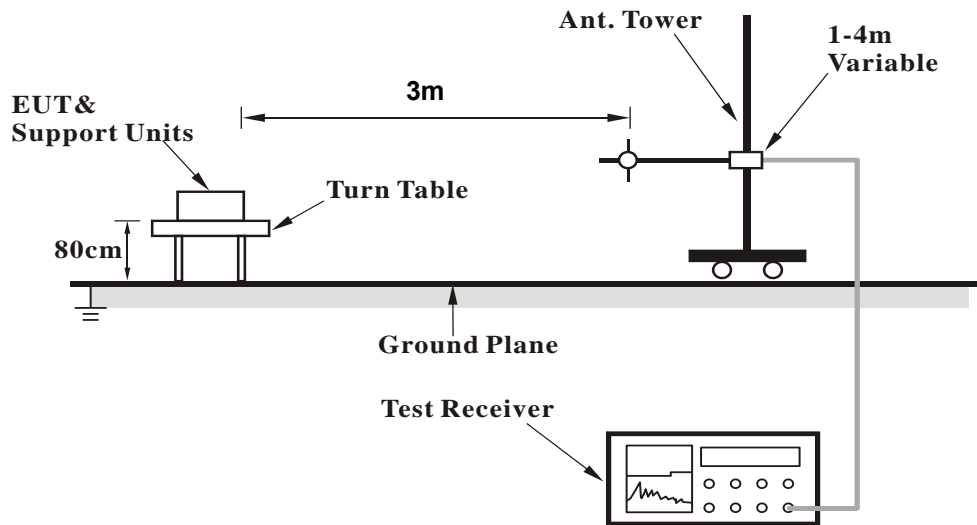

### For Radiated emission above 1GHz

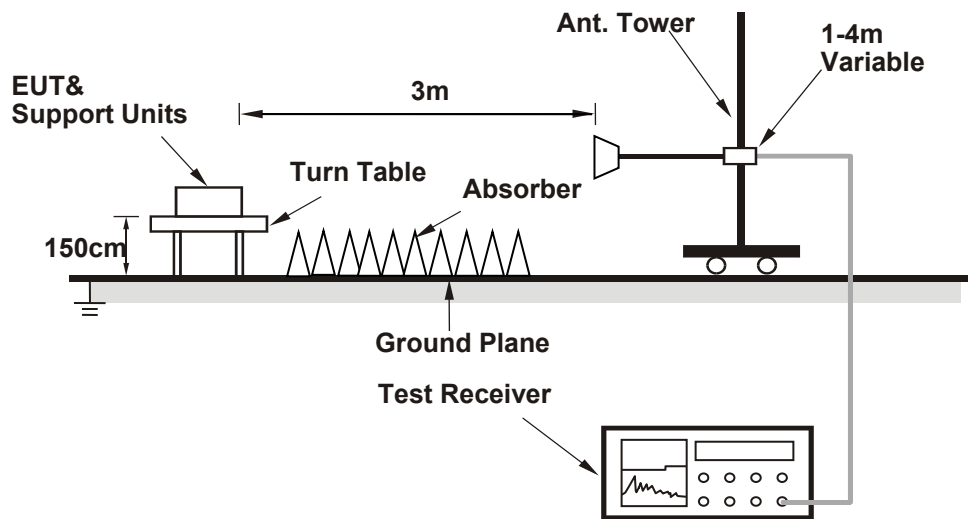

For the actual test configuration, please refer to the attached file (Test Setup Photo).

#### 4.1.5 EUT Operating Condition

- a. Connected the EUT with the Laptop which is placed on the testing table.
- b. Controlling software (MT7915 QA 0.0..15) has been activated to set the EUT under transmission condition continuously.

#### 4.1.6 Test Results

#### Above 1GHz Data:

#### 802.11a

RF Mode	TX 802.11a 6G	Channel	CH 1 : 5955 MHz
Frequency Range	1GHz ~ 40GHz	Detector Function	Peak (PK) Average (AV)

Antenna Polarity & Test Distance : Horizontal at 3 m								
No	Frequency (MHz)	Emission Level (dBuV/m)	Limit (dBuV/m)	Margin (dB)	Antenna Height (m)	Table Angle (Degree)	Raw Value (dBuV)	Correction Factor (dB/m)
1	#5925.00	56.0 PK	88.2	-32.2	2.06 H	80	53.8	2.2
2	#5925.00	44.9 AV	68.2	-23.3	2.06 H	80	42.7	2.2
3	*5955.00	100.6 PK			2.06 H	80	60.2	40.4
4	*5955.00	91.3 AV			2.06 H	80	50.9	40.4
5	11910.00	56.5 PK	74.0	-17.5	1.00 H	58	48.2	8.3
6	11910.00	45.3 AV	54.0	-8.7	1.00 H	58	37.0	8.3

Antenna Polarity & Test Distance : Vertical at 3 m								
No	Frequency (MHz)	Emission Level (dBuV/m)	Limit (dBuV/m)	Margin (dB)	Antenna Height (m)	Table Angle (Degree)	Raw Value (dBuV)	Correction Factor (dB/m)
1	#5925.00	56.8 PK	88.2	-31.4	2.05 V	197	54.6	2.2
2	#5925.00	44.9 AV	68.2	-23.3	2.05 V	197	42.7	2.2
3	*5955.00	93.5 PK			2.05 V	197	53.1	40.4
4	*5955.00	84.5 AV			2.05 V	197	44.1	40.4
5	11910.00	56.4 PK	74.0	-17.6	1.30 V	262	48.1	8.3
6	11910.00	45.1 AV	54.0	-8.9	1.30 V	262	36.8	8.3

#### Remarks:

1. Emission Level(dBuV/m) = Raw Value(dBuV) + Correction Factor(dB/m)
2. Correction Factor(dB/m) = Antenna Factor(dB/m) + Cable Factor(dB) – Pre-Amplifier Factor(dB)
3. Margin value = Emission Level – Limit value
4. The other emission levels were very low against the limit.
5. " \* ": Fundamental frequency.
6. " # ": The radiated frequency is out of the restricted band.



RF Mode	TX 802.11a 6G	Channel	CH 45 : 6175 MHz
Frequency Range	1GHz ~ 40GHz	Detector Function	Peak (PK) Average (AV)

**Antenna Polarity & Test Distance : Horizontal at 3 m**

No	Frequency (MHz)	Emission Level (dBuV/m)	Limit (dBuV/m)	Margin (dB)	Antenna Height (m)	Table Angle (Degree)	Raw Value (dBuV)	Correction Factor (dB/m)
1	*6175.00	102.0 PK			2.30 H	88	61.0	41.0
2	*6175.00	92.8 AV			2.30 H	88	51.8	41.0
3	12350.00	56.6 PK	74.0	-17.4	1.02 H	62	48.3	8.3
4	12350.00	45.4 AV	54.0	-8.6	1.02 H	62	37.1	8.3

**Antenna Polarity & Test Distance : Vertical at 3 m**

No	Frequency (MHz)	Emission Level (dBuV/m)	Limit (dBuV/m)	Margin (dB)	Antenna Height (m)	Table Angle (Degree)	Raw Value (dBuV)	Correction Factor (dB/m)
1	*6175.00	97.0 PK			2.04 V	159	56.0	41.0
2	*6175.00	87.9 AV			2.04 V	159	46.9	41.0
3	12350.00	56.6 PK	74.0	-17.4	1.34 V	269	48.3	8.3
4	12350.00	45.3 AV	54.0	-8.7	1.34 V	269	37.0	8.3

**Remarks:**

1. Emission Level(dBuV/m) = Raw Value(dBuV) + Correction Factor(dB/m)
2. Correction Factor(dB/m) = Antenna Factor(dB/m) + Cable Factor(dB) – Pre-Amplifier Factor(dB)
3. Margin value = Emission Level – Limit value
4. The other emission levels were very low against the limit.
5. " \* " : Fundamental frequency.

RF Mode	TX 802.11a 6G	Channel	CH 93 : 6415 MHz
Frequency Range	1GHz ~ 40GHz	Detector Function	Peak (PK) Average (AV)

**Antenna Polarity & Test Distance : Horizontal at 3 m**

No	Frequency (MHz)	Emission Level (dBuV/m)	Limit (dBuV/m)	Margin (dB)	Antenna Height (m)	Table Angle (Degree)	Raw Value (dBuV)	Correction Factor (dB/m)
1	*6415.00	102.7 PK			1.89 H	84	60.8	41.9
2	*6415.00	94.4 AV			1.89 H	84	52.5	41.9
3	#12830.00	57.4 PK	88.2	-30.8	1.10 H	69	48.5	8.9
4	#12830.00	46.2 AV	68.2	-22.0	1.10 H	69	37.3	8.9

**Antenna Polarity & Test Distance : Vertical at 3 m**

No	Frequency (MHz)	Emission Level (dBuV/m)	Limit (dBuV/m)	Margin (dB)	Antenna Height (m)	Table Angle (Degree)	Raw Value (dBuV)	Correction Factor (dB/m)
1	*6415.00	98.8 PK			2.18 V	130	56.9	41.9
2	*6415.00	90.7 AV			2.18 V	130	48.8	41.9
3	#12830.00	57.3 PK	88.2	-30.9	1.36 V	266	48.4	8.9
4	#12830.00	46.1 AV	68.2	-22.1	1.36 V	266	37.2	8.9

**Remarks:**

1. Emission Level(dBuV/m) = Raw Value(dBuV) + Correction Factor(dB/m)
2. Correction Factor(dB/m) = Antenna Factor(dB/m) + Cable Factor(dB) – Pre-Amplifier Factor(dB)
3. Margin value = Emission Level – Limit value
4. The other emission levels were very low against the limit.
5. " \* ": Fundamental frequency.
6. " # ": The radiated frequency is out of the restricted band.

RF Mode	TX 802.11a 6G	Channel	CH 97 : 6435 MHz
Frequency Range	1GHz ~ 40GHz	Detector Function	Peak (PK) Average (AV)

Antenna Polarity & Test Distance : Horizontal at 3 m								
No	Frequency (MHz)	Emission Level (dBuV/m)	Limit (dBuV/m)	Margin (dB)	Antenna Height (m)	Table Angle (Degree)	Raw Value (dBuV)	Correction Factor (dB/m)
1	*6435.00	104.6 PK			1.83 H	83	62.6	42.0
2	*6435.00	95.4 AV			1.83 H	83	53.4	42.0
3	#12870.00	57.4 PK	88.2	-30.8	1.07 H	64	48.6	8.8
4	#12870.00	46.0 AV	68.2	-22.2	1.07 H	64	37.2	8.8
Antenna Polarity & Test Distance : Vertical at 3 m								
No	Frequency (MHz)	Emission Level (dBuV/m)	Limit (dBuV/m)	Margin (dB)	Antenna Height (m)	Table Angle (Degree)	Raw Value (dBuV)	Correction Factor (dB/m)
1	*6435.00	102.1 PK			2.06 V	130	60.1	42.0
2	*6435.00	92.4 AV			2.06 V	130	50.4	42.0
3	#12870.00	57.3 PK	88.2	-30.9	1.37 V	261	48.5	8.8
4	#12870.00	46.2 AV	68.2	-22.0	1.37 V	261	37.4	8.8

Remarks:

1. Emission Level(dBuV/m) = Raw Value(dBuV) + Correction Factor(dB/m)
2. Correction Factor(dB/m) = Antenna Factor(dB/m) + Cable Factor(dB) – Pre-Amplifier Factor(dB)
3. Margin value = Emission Level – Limit value
4. The other emission levels were very low against the limit.
5. " \* ": Fundamental frequency.
6. " # ": The radiated frequency is out of the restricted band.

RF Mode	TX 802.11a 6G	Channel	CH 105 : 6475 MHz
Frequency Range	1GHz ~ 40GHz	Detector Function	Peak (PK) Average (AV)

Antenna Polarity & Test Distance : Horizontal at 3 m								
No	Frequency (MHz)	Emission Level (dBuV/m)	Limit (dBuV/m)	Margin (dB)	Antenna Height (m)	Table Angle (Degree)	Raw Value (dBuV)	Correction Factor (dB/m)
1	*6475.00	103.7 PK			1.88 H	84	61.6	42.1
2	*6475.00	95.4 AV			1.88 H	84	53.3	42.1
3	#12950.00	56.9 PK	88.2	-31.3	1.04 H	61	48.4	8.5
4	#12950.00	45.9 AV	68.2	-22.3	1.04 H	61	37.4	8.5
Antenna Polarity & Test Distance : Vertical at 3 m								
No	Frequency (MHz)	Emission Level (dBuV/m)	Limit (dBuV/m)	Margin (dB)	Antenna Height (m)	Table Angle (Degree)	Raw Value (dBuV)	Correction Factor (dB/m)
1	*6475.00	100.6 PK			2.05 V	129	58.5	42.1
2	*6475.00	92.4 AV			2.05 V	129	50.3	42.1
3	#12950.00	56.8 PK	88.2	-31.4	1.40 V	271	48.3	8.5
4	#12950.00	45.8 AV	68.2	-22.4	1.40 V	271	37.3	8.5

Remarks:

1. Emission Level(dBuV/m) = Raw Value(dBuV) + Correction Factor(dB/m)
2. Correction Factor(dB/m) = Antenna Factor(dB/m) + Cable Factor(dB) – Pre-Amplifier Factor(dB)
3. Margin value = Emission Level – Limit value
4. The other emission levels were very low against the limit.
5. " \* ": Fundamental frequency.
6. " # ": The radiated frequency is out of the restricted band.

RF Mode	TX 802.11a 6G	Channel	CH 113 : 6515 MHz
Frequency Range	1GHz ~ 40GHz	Detector Function	Peak (PK) Average (AV)

Antenna Polarity & Test Distance : Horizontal at 3 m								
No	Frequency (MHz)	Emission Level (dBuV/m)	Limit (dBuV/m)	Margin (dB)	Antenna Height (m)	Table Angle (Degree)	Raw Value (dBuV)	Correction Factor (dB/m)
1	*6515.00	103.9 PK			1.96 H	78	61.5	42.4
2	*6515.00	95.7 AV			1.96 H	78	53.3	42.4
3	#13030.00	56.6 PK	88.2	-31.6	1.06 H	63	48.3	8.3
4	#13030.00	45.5 AV	68.2	-22.7	1.06 H	63	37.2	8.3
Antenna Polarity & Test Distance : Vertical at 3 m								
No	Frequency (MHz)	Emission Level (dBuV/m)	Limit (dBuV/m)	Margin (dB)	Antenna Height (m)	Table Angle (Degree)	Raw Value (dBuV)	Correction Factor (dB/m)
1	*6515.00	100.2 PK			2.14 V	131	57.8	42.4
2	*6515.00	91.5 AV			2.14 V	131	49.1	42.4
3	#13030.00	56.8 PK	88.2	-31.4	1.35 V	272	48.5	8.3
4	#13030.00	45.8 AV	68.2	-22.4	1.35 V	272	37.5	8.3

Remarks:

1. Emission Level(dBuV/m) = Raw Value(dBuV) + Correction Factor(dB/m)
2. Correction Factor(dB/m) = Antenna Factor(dB/m) + Cable Factor(dB) – Pre-Amplifier Factor(dB)
3. Margin value = Emission Level – Limit value
4. The other emission levels were very low against the limit.
5. " \* ": Fundamental frequency.
6. " # ": The radiated frequency is out of the restricted band.

RF Mode	TX 802.11a 6G	Channel	CH 117 : 6535 MHz
Frequency Range	1GHz ~ 40GHz	Detector Function	Peak (PK) Average (AV)

**Antenna Polarity & Test Distance : Horizontal at 3 m**

No	Frequency (MHz)	Emission Level (dBuV/m)	Limit (dBuV/m)	Margin (dB)	Antenna Height (m)	Table Angle (Degree)	Raw Value (dBuV)	Correction Factor (dB/m)
1	*6535.00	104.5 PK			1.95 H	76	62.0	42.5
2	*6535.00	95.5 AV			1.95 H	76	53.0	42.5
3	#13070.00	56.9 PK	88.2	-31.3	1.11 H	66	48.6	8.3
4	#13070.00	45.8 AV	68.2	-22.4	1.11 H	66	37.5	8.3

**Antenna Polarity & Test Distance : Vertical at 3 m**

No	Frequency (MHz)	Emission Level (dBuV/m)	Limit (dBuV/m)	Margin (dB)	Antenna Height (m)	Table Angle (Degree)	Raw Value (dBuV)	Correction Factor (dB/m)
1	*6535.00	100.6 PK			1.95 V	128	58.1	42.5
2	*6535.00	91.7 AV			1.95 V	128	49.2	42.5
3	#13070.00	56.7 PK	88.2	-31.5	1.41 V	263	48.4	8.3
4	#13070.00	45.7 AV	68.2	-22.5	1.41 V	263	37.4	8.3

**Remarks:**

1. Emission Level(dBuV/m) = Raw Value(dBuV) + Correction Factor(dB/m)
2. Correction Factor(dB/m) = Antenna Factor(dB/m) + Cable Factor(dB) – Pre-Amplifier Factor(dB)
3. Margin value = Emission Level – Limit value
4. The other emission levels were very low against the limit.
5. " \* " : Fundamental frequency.
6. " # " : The radiated frequency is out of the restricted band.

RF Mode	TX 802.11a 6G	Channel	CH 149 : 6695 MHz
Frequency Range	1GHz ~ 40GHz	Detector Function	Peak (PK) Average (AV)

**Antenna Polarity & Test Distance : Horizontal at 3 m**

No	Frequency (MHz)	Emission Level (dBuV/m)	Limit (dBuV/m)	Margin (dB)	Antenna Height (m)	Table Angle (Degree)	Raw Value (dBuV)	Correction Factor (dB/m)
1	*6695.00	103.9 PK			2.19 H	81	61.2	42.7
2	*6695.00	95.4 AV			2.19 H	81	52.7	42.7
3	13390.00	57.2 PK	74.0	-16.8	1.10 H	67	48.4	8.8
4	13390.00	46.1 AV	54.0	-7.9	1.10 H	67	37.3	8.8

**Antenna Polarity & Test Distance : Vertical at 3 m**

No	Frequency (MHz)	Emission Level (dBuV/m)	Limit (dBuV/m)	Margin (dB)	Antenna Height (m)	Table Angle (Degree)	Raw Value (dBuV)	Correction Factor (dB/m)
1	*6695.00	98.5 PK			1.99 V	127	55.8	42.7
2	*6695.00	89.7 AV			1.99 V	127	47.0	42.7
3	13390.00	57.6 PK	74.0	-16.4	1.30 V	273	48.8	8.8
4	13390.00	46.5 AV	54.0	-7.5	1.30 V	273	37.7	8.8

**Remarks:**

1. Emission Level(dBuV/m) = Raw Value(dBuV) + Correction Factor(dB/m)
2. Correction Factor(dB/m) = Antenna Factor(dB/m) + Cable Factor(dB) – Pre-Amplifier Factor(dB)
3. Margin value = Emission Level – Limit value
4. The other emission levels were very low against the limit.
5. " \* " : Fundamental frequency.

RF Mode	TX 802.11a 6G	Channel	CH 181 : 6855 MHz
Frequency Range	1GHz ~ 40GHz	Detector Function	Peak (PK) Average (AV)

**Antenna Polarity & Test Distance : Horizontal at 3 m**

No	Frequency (MHz)	Emission Level (dBuV/m)	Limit (dBuV/m)	Margin (dB)	Antenna Height (m)	Table Angle (Degree)	Raw Value (dBuV)	Correction Factor (dB/m)
1	*6855.00	100.7 PK			1.83 H	130	57.6	43.1
2	*6855.00	92.4 AV			1.83 H	130	49.3	43.1
3	#13710.00	57.6 PK	88.2	-30.6	1.03 H	72	48.7	8.9
4	#13710.00	46.6 AV	68.2	-21.6	1.03 H	72	37.7	8.9

**Antenna Polarity & Test Distance : Vertical at 3 m**

No	Frequency (MHz)	Emission Level (dBuV/m)	Limit (dBuV/m)	Margin (dB)	Antenna Height (m)	Table Angle (Degree)	Raw Value (dBuV)	Correction Factor (dB/m)
1	*6855.00	96.7 PK			1.97 V	103	53.6	43.1
2	*6855.00	87.3 AV			1.97 V	103	44.2	43.1
3	#13710.00	57.4 PK	88.2	-30.8	1.33 V	277	48.5	8.9
4	#13710.00	46.5 AV	68.2	-21.7	1.33 V	277	37.6	8.9

**Remarks:**

1. Emission Level(dBuV/m) = Raw Value(dBuV) + Correction Factor(dB/m)
2. Correction Factor(dB/m) = Antenna Factor(dB/m) + Cable Factor(dB) – Pre-Amplifier Factor(dB)
3. Margin value = Emission Level – Limit value
4. The other emission levels were very low against the limit.
5. " \* " : Fundamental frequency.
6. " # " : The radiated frequency is out of the restricted band.



RF Mode	TX 802.11a 6G	Channel	CH 185 : 6875 MHz
Frequency Range	1GHz ~ 40GHz	Detector Function	Peak (PK) Average (AV)

Antenna Polarity & Test Distance : Horizontal at 3 m								
No	Frequency (MHz)	Emission Level (dBuV/m)	Limit (dBuV/m)	Margin (dB)	Antenna Height (m)	Table Angle (Degree)	Raw Value (dBuV)	Correction Factor (dB/m)
1	*6875.00	101.6 PK			1.85 H	129	58.5	43.1
2	*6875.00	91.8 AV			1.85 H	129	48.7	43.1
3	#13750.00	57.9 PK	88.2	-30.3	1.12 H	70	48.9	9.0
4	#13750.00	46.8 AV	68.2	-21.4	1.12 H	70	37.8	9.0
Antenna Polarity & Test Distance : Vertical at 3 m								
No	Frequency (MHz)	Emission Level (dBuV/m)	Limit (dBuV/m)	Margin (dB)	Antenna Height (m)	Table Angle (Degree)	Raw Value (dBuV)	Correction Factor (dB/m)
1	*6875.00	96.5 PK			2.07 V	100	53.4	43.1
2	*6875.00	87.7 AV			2.07 V	100	44.6	43.1
3	#13750.00	57.6 PK	88.2	-30.6	1.43 V	275	48.6	9.0
4	#13750.00	46.5 AV	68.2	-21.7	1.43 V	275	37.5	9.0

Remarks:

1. Emission Level(dBuV/m) = Raw Value(dBuV) + Correction Factor(dB/m)
2. Correction Factor(dB/m) = Antenna Factor(dB/m) + Cable Factor(dB) – Pre-Amplifier Factor(dB)
3. Margin value = Emission Level – Limit value
4. The other emission levels were very low against the limit.
5. " \* ": Fundamental frequency.
6. " # ": The radiated frequency is out of the restricted band.

RF Mode	TX 802.11a 6G	Channel	CH 209 : 6995 MHz
Frequency Range	1GHz ~ 40GHz	Detector Function	Peak (PK) Average (AV)

**Antenna Polarity & Test Distance : Horizontal at 3 m**

No	Frequency (MHz)	Emission Level (dBuV/m)	Limit (dBuV/m)	Margin (dB)	Antenna Height (m)	Table Angle (Degree)	Raw Value (dBuV)	Correction Factor (dB/m)
1	*6995.00	104.6 PK			1.86 H	95	60.9	43.7
2	*6995.00	95.4 AV			1.86 H	95	51.7	43.7
3	#13990.00	58.6 PK	88.2	-29.6	1.09 H	68	48.7	9.9
4	#13990.00	47.5 AV	68.2	-20.7	1.09 H	68	37.6	9.9

**Antenna Polarity & Test Distance : Vertical at 3 m**

No	Frequency (MHz)	Emission Level (dBuV/m)	Limit (dBuV/m)	Margin (dB)	Antenna Height (m)	Table Angle (Degree)	Raw Value (dBuV)	Correction Factor (dB/m)
1	*6995.00	100.2 PK			2.06 V	106	56.5	43.7
2	*6995.00	90.2 AV			2.06 V	106	46.5	43.7
3	#13990.00	58.4 PK	88.2	-29.8	1.37 V	271	48.5	9.9
4	#13990.00	47.6 AV	68.2	-20.6	1.37 V	271	37.7	9.9

**Remarks:**

1. Emission Level(dBuV/m) = Raw Value(dBuV) + Correction Factor(dB/m)
2. Correction Factor(dB/m) = Antenna Factor(dB/m) + Cable Factor(dB) – Pre-Amplifier Factor(dB)
3. Margin value = Emission Level – Limit value
4. The other emission levels were very low against the limit.
5. " \* " : Fundamental frequency.
6. " # " : The radiated frequency is out of the restricted band.

RF Mode	TX 802.11a 6G	Channel	CH 233 : 7115 MHz
Frequency Range	1GHz ~ 40GHz	Detector Function	Peak (PK) Average (AV)

**Antenna Polarity & Test Distance : Horizontal at 3 m**

No	Frequency (MHz)	Emission Level (dBuV/m)	Limit (dBuV/m)	Margin (dB)	Antenna Height (m)	Table Angle (Degree)	Raw Value (dBuV)	Correction Factor (dB/m)
1	*7115.00	104.8 PK			2.14 H	82	60.2	44.6
2	*7115.00	96.3 AV			2.14 H	82	51.7	44.6
3	#7125.00	72.1 PK	88.2	-16.1	2.14 H	82	66.0	6.1
4	#7125.00	55.4 AV	68.2	-12.8	2.14 H	82	49.3	6.1
5	#14230.00	60.8 PK	88.2	-27.4	1.05 H	60	50.6	10.2
6	#14230.00	49.0 AV	68.2	-19.2	1.05 H	60	38.8	10.2

**Antenna Polarity & Test Distance : Vertical at 3 m**

No	Frequency (MHz)	Emission Level (dBuV/m)	Limit (dBuV/m)	Margin (dB)	Antenna Height (m)	Table Angle (Degree)	Raw Value (dBuV)	Correction Factor (dB/m)
1	*7115.00	104.1 PK			2.07 V	226	59.5	44.6
2	*7115.00	94.1 AV			2.07 V	226	49.5	44.6
3	#7125.00	72.0 PK	88.2	-16.2	2.07 V	226	65.9	6.1
4	#7125.00	54.7 AV	68.2	-13.5	2.07 V	226	48.6	6.1
5	#14230.00	60.8 PK	88.2	-27.4	1.33 V	264	50.6	10.2
6	#14230.00	49.0 AV	68.2	-19.2	1.33 V	264	38.8	10.2

**Remarks:**

1. Emission Level(dBuV/m) = Raw Value(dBuV) + Correction Factor(dB/m)
2. Correction Factor(dB/m) = Antenna Factor(dB/m) + Cable Factor(dB) – Pre-Amplifier Factor(dB)
3. Margin value = Emission Level – Limit value
4. The other emission levels were very low against the limit.
5. " \* " : Fundamental frequency.
6. " # " : The radiated frequency is out of the restricted band.

### 802.11ax (HE20)

RF Mode	TX 802.11ax (HE20)	Channel	CH 1 : 5955 MHz
Frequency Range	1GHz ~ 40GHz	Detector Function	Peak (PK) Average (AV)

#### Antenna Polarity & Test Distance : Horizontal at 3 m

No	Frequency (MHz)	Emission Level (dBuV/m)	Limit (dBuV/m)	Margin (dB)	Antenna Height (m)	Table Angle (Degree)	Raw Value (dBuV)	Correction Factor (dB/m)
1	#5925.00	66.5 PK	88.2	-21.7	1.00 H	294	64.2	2.3
2	#5925.00	52.8 AV	68.2	-15.4	1.00 H	294	50.5	2.3
3	*5955.00	110.1 PK			1.00 H	294	69.6	40.5
4	*5955.00	99.5 AV			1.00 H	294	59.0	40.5
5	11910.00	56.4 PK	74.0	-17.6	1.00 H	63	47.9	8.5
6	11910.00	45.9 AV	54.0	-8.1	1.00 H	63	37.4	8.5

#### Antenna Polarity & Test Distance : Vertical at 3 m

No	Frequency (MHz)	Emission Level (dBuV/m)	Limit (dBuV/m)	Margin (dB)	Antenna Height (m)	Table Angle (Degree)	Raw Value (dBuV)	Correction Factor (dB/m)
1	#5925.00	77.2 PK	88.2	-11.0	1.01 V	223	74.9	2.3
2	#5925.00	62.3 AV	68.2	-5.9	1.01 V	223	60.0	2.3
3	*5955.00	119.9 PK			1.01 V	223	79.4	40.5
4	*5955.00	106.3 AV			1.01 V	223	65.8	40.5
5	11910.00	55.7 PK	74.0	-18.3	1.10 V	288	47.2	8.5
6	11910.00	45.4 AV	54.0	-8.6	1.10 V	288	36.9	8.5

#### Remarks:

1. Emission Level(dBuV/m) = Raw Value(dBuV) + Correction Factor(dB/m)
2. Correction Factor(dB/m) = Antenna Factor(dB/m) + Cable Factor(dB) – Pre-Amplifier Factor(dB)
3. Margin value = Emission Level – Limit value
4. The other emission levels were very low against the limit.
5. " \* " : Fundamental frequency.
6. " # " : The radiated frequency is out of the restricted band.

RF Mode	TX 802.11ax (HE20)	Channel	CH 45 : 6175 MHz
Frequency Range	1GHz ~ 40GHz	Detector Function	Peak (PK) Average (AV)

**Antenna Polarity & Test Distance : Horizontal at 3 m**

No	Frequency (MHz)	Emission Level (dBuV/m)	Limit (dBuV/m)	Margin (dB)	Antenna Height (m)	Table Angle (Degree)	Raw Value (dBuV)	Correction Factor (dB/m)
1	*6175.00	110.4 PK			1.13 H	295	69.3	41.1
2	*6175.00	99.7 AV			1.13 H	295	58.6	41.1
3	12350.00	56.2 PK	74.0	-17.8	1.05 H	66	47.9	8.3
4	12350.00	45.6 AV	54.0	-8.4	1.05 H	66	37.3	8.3

**Antenna Polarity & Test Distance : Vertical at 3 m**

No	Frequency (MHz)	Emission Level (dBuV/m)	Limit (dBuV/m)	Margin (dB)	Antenna Height (m)	Table Angle (Degree)	Raw Value (dBuV)	Correction Factor (dB/m)
1	*6175.00	117.9 PK			1.00 V	229	76.8	41.1
2	*6175.00	105.8 AV			1.00 V	229	64.7	41.1
3	12350.00	55.8 PK	74.0	-18.2	1.13 V	287	47.5	8.3
4	12350.00	45.2 AV	54.0	-8.8	1.13 V	287	36.9	8.3

**Remarks:**

1. Emission Level(dBuV/m) = Raw Value(dBuV) + Correction Factor(dB/m)
2. Correction Factor(dB/m) = Antenna Factor(dB/m) + Cable Factor(dB) – Pre-Amplifier Factor(dB)
3. Margin value = Emission Level – Limit value
4. The other emission levels were very low against the limit.
5. " \* " : Fundamental frequency.

RF Mode	TX 802.11ax (HE20)	Channel	CH 93 : 6415 MHz
Frequency Range	1GHz ~ 40GHz	Detector Function	Peak (PK) Average (AV)

Antenna Polarity & Test Distance : Horizontal at 3 m								
No	Frequency (MHz)	Emission Level (dBuV/m)	Limit (dBuV/m)	Margin (dB)	Antenna Height (m)	Table Angle (Degree)	Raw Value (dBuV)	Correction Factor (dB/m)
1	*6415.00	110.6 PK			1.00 H	295	68.5	42.1
2	*6415.00	100.4 AV			1.00 H	295	58.3	42.1
3	#12830.00	56.3 PK	88.2	-31.9	1.07 H	63	47.4	8.9
4	#12830.00	46.5 AV	68.2	-21.7	1.07 H	63	37.6	8.9
Antenna Polarity & Test Distance : Vertical at 3 m								
No	Frequency (MHz)	Emission Level (dBuV/m)	Limit (dBuV/m)	Margin (dB)	Antenna Height (m)	Table Angle (Degree)	Raw Value (dBuV)	Correction Factor (dB/m)
1	*6415.00	115.7 PK			1.01 V	227	73.6	42.1
2	*6415.00	104.6 AV			1.01 V	227	62.5	42.1
3	#12830.00	55.7 PK	88.2	-32.5	1.15 V	293	46.8	8.9
4	#12830.00	45.6 AV	68.2	-22.6	1.15 V	293	36.7	8.9

Remarks:

1. Emission Level(dBuV/m) = Raw Value(dBuV) + Correction Factor(dB/m)
2. Correction Factor(dB/m) = Antenna Factor(dB/m) + Cable Factor(dB) – Pre-Amplifier Factor(dB)
3. Margin value = Emission Level – Limit value
4. The other emission levels were very low against the limit.
5. " \* ": Fundamental frequency.
6. " # ": The radiated frequency is out of the restricted band.

RF Mode	TX 802.11ax (HE20)	Channel	CH 97 : 6435 MHz
Frequency Range	1GHz ~ 40GHz	Detector Function	Peak (PK) Average (AV)

Antenna Polarity & Test Distance : Horizontal at 3 m								
No	Frequency (MHz)	Emission Level (dBuV/m)	Limit (dBuV/m)	Margin (dB)	Antenna Height (m)	Table Angle (Degree)	Raw Value (dBuV)	Correction Factor (dB/m)
1	*6435.00	112.9 PK			1.90 H	147	70.7	42.2
2	*6435.00	102.0 AV			1.90 H	147	59.8	42.2
3	#12870.00	63.2 PK	88.2	-25.0	2.03 H	227	54.4	8.8
4	#12870.00	52.4 AV	68.2	-15.8	2.03 H	227	43.6	8.8
Antenna Polarity & Test Distance : Vertical at 3 m								
No	Frequency (MHz)	Emission Level (dBuV/m)	Limit (dBuV/m)	Margin (dB)	Antenna Height (m)	Table Angle (Degree)	Raw Value (dBuV)	Correction Factor (dB/m)
1	*6435.00	118.8 PK			2.01 V	81	76.6	42.2
2	*6435.00	106.5 AV			2.01 V	81	64.3	42.2
3	#12870.00	59.6 PK	88.2	-28.6	2.10 V	286	50.8	8.8
4	#12870.00	49.0 AV	68.2	-19.2	2.10 V	286	40.2	8.8

Remarks:

1. Emission Level(dBuV/m) = Raw Value(dBuV) + Correction Factor(dB/m)
2. Correction Factor(dB/m) = Antenna Factor(dB/m) + Cable Factor(dB) – Pre-Amplifier Factor(dB)
3. Margin value = Emission Level – Limit value
4. The other emission levels were very low against the limit.
5. " \* ": Fundamental frequency.
6. " # ": The radiated frequency is out of the restricted band.

RF Mode	TX 802.11ax (HE20)	Channel	CH 105 : 6475 MHz
Frequency Range	1GHz ~ 40GHz	Detector Function	Peak (PK) Average (AV)

Antenna Polarity & Test Distance : Horizontal at 3 m								
No	Frequency (MHz)	Emission Level (dBuV/m)	Limit (dBuV/m)	Margin (dB)	Antenna Height (m)	Table Angle (Degree)	Raw Value (dBuV)	Correction Factor (dB/m)
1	*6475.00	112.9 PK			1.85 H	149	70.6	42.3
2	*6475.00	101.5 AV			1.85 H	149	59.2	42.3
3	#12950.00	63.0 PK	88.2	-25.2	1.89 H	226	54.5	8.5
4	#12950.00	53.0 AV	68.2	-15.2	1.89 H	226	44.5	8.5
Antenna Polarity & Test Distance : Vertical at 3 m								
No	Frequency (MHz)	Emission Level (dBuV/m)	Limit (dBuV/m)	Margin (dB)	Antenna Height (m)	Table Angle (Degree)	Raw Value (dBuV)	Correction Factor (dB/m)
1	*6475.00	118.8 PK			2.03 V	76	76.5	42.3
2	*6475.00	106.4 AV			2.03 V	76	64.1	42.3
3	#12950.00	59.0 PK	88.2	-29.2	2.11 V	285	50.5	8.5
4	#12950.00	48.9 AV	68.2	-19.3	2.11 V	285	40.4	8.5

Remarks:

1. Emission Level(dBuV/m) = Raw Value(dBuV) + Correction Factor(dB/m)
2. Correction Factor(dB/m) = Antenna Factor(dB/m) + Cable Factor(dB) – Pre-Amplifier Factor(dB)
3. Margin value = Emission Level – Limit value
4. The other emission levels were very low against the limit.
5. " \* ": Fundamental frequency.
6. " # ": The radiated frequency is out of the restricted band.



RF Mode	TX 802.11ax (HE20)	Channel	CH 113 : 6515 MHz
Frequency Range	1GHz ~ 40GHz	Detector Function	Peak (PK) Average (AV)

**Antenna Polarity & Test Distance : Horizontal at 3 m**

No	Frequency (MHz)	Emission Level (dBuV/m)	Limit (dBuV/m)	Margin (dB)	Antenna Height (m)	Table Angle (Degree)	Raw Value (dBuV)	Correction Factor (dB/m)
1	*6515.00	112.9 PK			1.88 H	150	70.4	42.5
2	*6515.00	101.9 AV			1.88 H	150	59.4	42.5
3	#13030.00	62.4 PK	88.2	-25.8	1.96 H	226	54.0	8.4
4	#13030.00	52.6 AV	68.2	-15.6	1.96 H	226	44.2	8.4

**Antenna Polarity & Test Distance : Vertical at 3 m**

No	Frequency (MHz)	Emission Level (dBuV/m)	Limit (dBuV/m)	Margin (dB)	Antenna Height (m)	Table Angle (Degree)	Raw Value (dBuV)	Correction Factor (dB/m)
1	*6515.00	118.4 PK			1.98 V	79	75.9	42.5
2	*6515.00	106.3 AV			1.98 V	79	63.8	42.5
3	#13030.00	59.0 PK	88.2	-29.2	2.13 V	287	50.6	8.4
4	#13030.00	48.9 AV	68.2	-19.3	2.13 V	287	40.5	8.4

**Remarks:**

1. Emission Level(dBuV/m) = Raw Value(dBuV) + Correction Factor(dB/m)
2. Correction Factor(dB/m) = Antenna Factor(dB/m) + Cable Factor(dB) – Pre-Amplifier Factor(dB)
3. Margin value = Emission Level – Limit value
4. The other emission levels were very low against the limit.
5. " \* " : Fundamental frequency.
6. " # " : The radiated frequency is out of the restricted band.

RF Mode	TX 802.11ax (HE20)	Channel	CH 117 : 6535 MHz
Frequency Range	1GHz ~ 40GHz	Detector Function	Peak (PK) Average (AV)

Antenna Polarity & Test Distance : Horizontal at 3 m								
No	Frequency (MHz)	Emission Level (dBuV/m)	Limit (dBuV/m)	Margin (dB)	Antenna Height (m)	Table Angle (Degree)	Raw Value (dBuV)	Correction Factor (dB/m)
1	*6535.00	111.1 PK			1.98 H	147	68.5	42.6
2	*6535.00	101.6 AV			1.98 H	147	59.0	42.6
3	#13070.00	61.8 PK	88.2	-26.4	1.50 H	226	53.5	8.3
4	#13070.00	52.8 AV	68.2	-15.4	1.50 H	226	44.5	8.3
Antenna Polarity & Test Distance : Vertical at 3 m								
No	Frequency (MHz)	Emission Level (dBuV/m)	Limit (dBuV/m)	Margin (dB)	Antenna Height (m)	Table Angle (Degree)	Raw Value (dBuV)	Correction Factor (dB/m)
1	*6535.00	118.8 PK			2.00 V	77	76.2	42.6
2	*6535.00	106.9 AV			2.00 V	77	64.3	42.6
3	#13070.00	58.9 PK	88.2	-29.3	2.13 V	286	50.6	8.3
4	#13070.00	48.8 AV	68.2	-19.4	2.13 V	286	40.5	8.3

Remarks:

1. Emission Level(dBuV/m) = Raw Value(dBuV) + Correction Factor(dB/m)
2. Correction Factor(dB/m) = Antenna Factor(dB/m) + Cable Factor(dB) – Pre-Amplifier Factor(dB)
3. Margin value = Emission Level – Limit value
4. The other emission levels were very low against the limit.
5. " \* ": Fundamental frequency.
6. " # ": The radiated frequency is out of the restricted band.

RF Mode	TX 802.11ax (HE20)	Channel	CH 149 : 6695 MHz
Frequency Range	1GHz ~ 40GHz	Detector Function	Peak (PK) Average (AV)

**Antenna Polarity & Test Distance : Horizontal at 3 m**

No	Frequency (MHz)	Emission Level (dBuV/m)	Limit (dBuV/m)	Margin (dB)	Antenna Height (m)	Table Angle (Degree)	Raw Value (dBuV)	Correction Factor (dB/m)
1	*6695.00	111.3 PK			2.01 H	148	68.4	42.9
2	*6695.00	101.6 AV			2.01 H	148	58.7	42.9
3	13390.00	61.6 PK	74.0	-12.4	1.62 H	227	52.8	8.8
4	13390.00	52.2 AV	54.0	-1.8	1.62 H	227	43.4	8.8

**Antenna Polarity & Test Distance : Vertical at 3 m**

No	Frequency (MHz)	Emission Level (dBuV/m)	Limit (dBuV/m)	Margin (dB)	Antenna Height (m)	Table Angle (Degree)	Raw Value (dBuV)	Correction Factor (dB/m)
1	*6695.00	118.6 PK			1.96 V	81	75.7	42.9
2	*6695.00	106.2 AV			1.96 V	81	63.3	42.9
3	13390.00	58.6 PK	74.0	-15.4	2.11 V	291	49.8	8.8
4	13390.00	48.9 AV	54.0	-5.1	2.11 V	191	40.1	8.8

**Remarks:**

1. Emission Level(dBuV/m) = Raw Value(dBuV) + Correction Factor(dB/m)
2. Correction Factor(dB/m) = Antenna Factor(dB/m) + Cable Factor(dB) – Pre-Amplifier Factor(dB)
3. Margin value = Emission Level – Limit value
4. The other emission levels were very low against the limit.
5. " \* ": Fundamental frequency.

RF Mode	TX 802.11ax (HE20)	Channel	CH 181 : 6855 MHz
Frequency Range	1GHz ~ 40GHz	Detector Function	Peak (PK) Average (AV)

**Antenna Polarity & Test Distance : Horizontal at 3 m**

No	Frequency (MHz)	Emission Level (dBuV/m)	Limit (dBuV/m)	Margin (dB)	Antenna Height (m)	Table Angle (Degree)	Raw Value (dBuV)	Correction Factor (dB/m)
1	*6855.00	111.8 PK			2.00 H	150	68.6	43.2
2	*6855.00	102.5 AV			2.00 H	150	59.3	43.2
3	#13710.00	63.1 PK	88.2	-25.1	1.58 H	227	54.2	8.9
4	#13710.00	53.4 AV	68.2	-14.8	1.58 H	227	44.5	8.9

**Antenna Polarity & Test Distance : Vertical at 3 m**

No	Frequency (MHz)	Emission Level (dBuV/m)	Limit (dBuV/m)	Margin (dB)	Antenna Height (m)	Table Angle (Degree)	Raw Value (dBuV)	Correction Factor (dB/m)
1	*6855.00	118.7 PK			1.99 V	73	75.5	43.2
2	*6855.00	106.6 AV			1.99 V	73	63.4	43.2
3	#13710.00	58.5 PK	88.2	-29.7	2.09 V	289	49.6	8.9
4	#13710.00	49.2 AV	68.2	-19.0	2.09 V	289	40.3	8.9

**Remarks:**

1. Emission Level(dBuV/m) = Raw Value(dBuV) + Correction Factor(dB/m)
2. Correction Factor(dB/m) = Antenna Factor(dB/m) + Cable Factor(dB) – Pre-Amplifier Factor(dB)
3. Margin value = Emission Level – Limit value
4. The other emission levels were very low against the limit.
5. " \* " : Fundamental frequency.
6. " # " : The radiated frequency is out of the restricted band.

RF Mode	TX 802.11ax (HE20)	Channel	CH 185 : 6875 MHz
Frequency Range	1GHz ~ 40GHz	Detector Function	Peak (PK) Average (AV)

Antenna Polarity & Test Distance : Horizontal at 3 m								
No	Frequency (MHz)	Emission Level (dBuV/m)	Limit (dBuV/m)	Margin (dB)	Antenna Height (m)	Table Angle (Degree)	Raw Value (dBuV)	Correction Factor (dB/m)
1	*6875.00	110.9 PK			1.93 H	155	67.6	43.3
2	*6875.00	101.9 AV			1.93 H	155	58.6	43.3
3	#13750.00	63.3 PK	88.2	-24.9	1.50 H	224	54.2	9.1
4	#13750.00	52.9 AV	68.2	-15.3	1.50 H	224	43.8	9.1
Antenna Polarity & Test Distance : Vertical at 3 m								
No	Frequency (MHz)	Emission Level (dBuV/m)	Limit (dBuV/m)	Margin (dB)	Antenna Height (m)	Table Angle (Degree)	Raw Value (dBuV)	Correction Factor (dB/m)
1	*6875.00	118.1 PK			2.10 V	68	74.8	43.3
2	*6875.00	106.8 AV			2.10 V	68	63.5	43.3
3	#13750.00	59.3 PK	88.2	-28.9	2.04 V	293	50.2	9.1
4	#13750.00	49.3 AV	68.2	-18.9	2.04 V	293	40.2	9.1

Remarks:

1. Emission Level(dBuV/m) = Raw Value(dBuV) + Correction Factor(dB/m)
2. Correction Factor(dB/m) = Antenna Factor(dB/m) + Cable Factor(dB) – Pre-Amplifier Factor(dB)
3. Margin value = Emission Level – Limit value
4. The other emission levels were very low against the limit.
5. " \* ": Fundamental frequency.
6. " # ": The radiated frequency is out of the restricted band.

RF Mode	TX 802.11ax (HE20)	Channel	CH 209 : 6995 MHz
Frequency Range	1GHz ~ 40GHz	Detector Function	Peak (PK) Average (AV)

Antenna Polarity & Test Distance : Horizontal at 3 m								
No	Frequency (MHz)	Emission Level (dBuV/m)	Limit (dBuV/m)	Margin (dB)	Antenna Height (m)	Table Angle (Degree)	Raw Value (dBuV)	Correction Factor (dB/m)
1	*6995.00	110.4 PK			3.34 H	154	66.6	43.8
2	*6995.00	99.7 AV			3.34 H	154	55.9	43.8
3	#7125.00	65.4 PK	88.2	-22.8	3.34 H	154	59.2	6.2
4	#7125.00	53.7 AV	68.2	-14.5	3.34 H	154	47.5	6.2
5	#13990.00	63.0 PK	88.2	-25.2	3.34 H	50	53.1	9.9
6	#13990.00	52.9 AV	68.2	-15.3	3.34 H	50	43.0	9.9

Antenna Polarity & Test Distance : Vertical at 3 m								
No	Frequency (MHz)	Emission Level (dBuV/m)	Limit (dBuV/m)	Margin (dB)	Antenna Height (m)	Table Angle (Degree)	Raw Value (dBuV)	Correction Factor (dB/m)
1	*6995.00	118.1 PK			1.67 V	231	74.3	43.8
2	*6995.00	106.5 AV			1.67 V	231	62.7	43.8
3	#7125.00	69.6 PK	88.2	-18.6	1.67 V	231	63.4	6.2
4	#7125.00	60.0 AV	68.2	-8.2	1.67 V	231	53.8	6.2
5	#13990.00	61.6 PK	88.2	-26.6	3.20 V	216	51.7	9.9
6	#13990.00	50.7 AV	68.2	-17.5	3.20 V	216	40.8	9.9

Remarks:

1. Emission Level(dBuV/m) = Raw Value(dBuV) + Correction Factor(dB/m)
2. Correction Factor(dB/m) = Antenna Factor(dB/m) + Cable Factor(dB) – Pre-Amplifier Factor(dB)
3. Margin value = Emission Level – Limit value
4. The other emission levels were very low against the limit.
5. " \* ": Fundamental frequency.
6. " # ": The radiated frequency is out of the restricted band.

RF Mode	TX 802.11ax (HE20)	Channel	CH 229 : 7095 MHz
Frequency Range	1GHz ~ 40GHz	Detector Function	Peak (PK) Average (AV)

Antenna Polarity & Test Distance : Horizontal at 3 m								
No	Frequency (MHz)	Emission Level (dBuV/m)	Limit (dBuV/m)	Margin (dB)	Antenna Height (m)	Table Angle (Degree)	Raw Value (dBuV)	Correction Factor (dB/m)
1	*7095.00	109.6 PK			3.01 H	141	64.9	44.7
2	*7095.00	98.0 AV			3.01 H	141	53.3	44.7
3	#7125.00	73.8 PK	88.2	-14.4	3.01 H	141	67.6	6.2
4	#7125.00	58.7 AV	68.2	-9.5	3.01 H	141	52.5	6.2
5	#14190.00	61.2 PK	88.2	-27.0	3.32 H	60	51.1	10.1
6	#14190.00	50.9 AV	68.2	-17.3	3.32 H	60	40.8	10.1

Antenna Polarity & Test Distance : Vertical at 3 m								
No	Frequency (MHz)	Emission Level (dBuV/m)	Limit (dBuV/m)	Margin (dB)	Antenna Height (m)	Table Angle (Degree)	Raw Value (dBuV)	Correction Factor (dB/m)
1	*7095.00	115.5 PK			1.00 V	236	70.8	44.7
2	*7095.00	105.5 AV			1.00 V	236	60.8	44.7
3	#7125.00	80.1 PK	88.2	-8.1	1.00 V	236	73.9	6.2
4	#7125.00	67.6 AV	68.2	-0.6	1.00 V	236	61.4	6.2
5	#14190.00	61.0 PK	88.2	-27.2	3.22 V	216	50.9	10.1
6	#14190.00	50.6 AV	68.2	-17.6	3.22 V	216	40.5	10.1

Remarks:

1. Emission Level(dBuV/m) = Raw Value(dBuV) + Correction Factor(dB/m)
2. Correction Factor(dB/m) = Antenna Factor(dB/m) + Cable Factor(dB) – Pre-Amplifier Factor(dB)
3. Margin value = Emission Level – Limit value
4. The other emission levels were very low against the limit.
5. " \* " : Fundamental frequency.
6. " # " : The radiated frequency is out of the restricted band.

RF Mode	TX 802.11ax (HE20)	Channel	CH 233 : 7115 MHz
Frequency Range	1GHz ~ 40GHz	Detector Function	Peak (PK) Average (AV)

Antenna Polarity & Test Distance : Horizontal at 3 m								
No	Frequency (MHz)	Emission Level (dBuV/m)	Limit (dBuV/m)	Margin (dB)	Antenna Height (m)	Table Angle (Degree)	Raw Value (dBuV)	Correction Factor (dB/m)
1	*7115.00	92.4 PK			2.19 H	83	47.8	44.6
2	*7115.00	82.4 AV			2.19 H	83	37.8	44.6
3	#7125.00	74.5 PK	88.2	-13.7	2.19 H	83	68.4	6.1
4	<b>#7125.00</b>	<b>67.9 AV</b>	<b>68.2</b>	<b>-0.3</b>	<b>2.19 H</b>	<b>83</b>	<b>61.8</b>	<b>6.1</b>
5	#14230.00	60.3 PK	88.2	-27.9	1.08 H	63	50.1	10.2
6	#14230.00	50.2 AV	68.2	-18.0	1.08 H	63	40.0	10.2
Antenna Polarity & Test Distance : Vertical at 3 m								
No	Frequency (MHz)	Emission Level (dBuV/m)	Limit (dBuV/m)	Margin (dB)	Antenna Height (m)	Table Angle (Degree)	Raw Value (dBuV)	Correction Factor (dB/m)
1	*7115.00	91.2 PK			2.05 V	223	46.6	44.6
2	*7115.00	80.1 AV			2.05 V	223	35.5	44.6
3	#7125.00	73.6 PK	88.2	-14.6	2.05 V	223	67.5	6.1
4	#7125.00	65.9 AV	68.2	-2.3	2.05 V	223	59.8	6.1
5	#14230.00	60.3 PK	88.2	-27.9	1.35 V	268	50.1	10.2
6	#14230.00	49.3 AV	68.2	-18.9	1.35 V	268	39.1	10.2

Remarks:

1. Emission Level(dBuV/m) = Raw Value(dBuV) + Correction Factor(dB/m)
2. Correction Factor(dB/m) = Antenna Factor(dB/m) + Cable Factor(dB) – Pre-Amplifier Factor(dB)
3. Margin value = Emission Level – Limit value
4. The other emission levels were very low against the limit.
5. " \* " : Fundamental frequency.
6. " # " : The radiated frequency is out of the restricted band.



**802.11ax (HE40)**

RF Mode	TX 802.11ax (HE40)	Channel	CH 3 : 5965 MHz
Frequency Range	1GHz ~ 40GHz	Detector Function	Peak (PK) Average (AV)

Antenna Polarity & Test Distance : Horizontal at 3 m								
No	Frequency (MHz)	Emission Level (dBuV/m)	Limit (dBuV/m)	Margin (dB)	Antenna Height (m)	Table Angle (Degree)	Raw Value (dBuV)	Correction Factor (dB/m)
1	#5925.00	66.9 PK	88.2	-21.3	1.08 H	293	64.6	2.3
2	#5925.00	54.9 AV	68.2	-13.3	1.08 H	293	52.6	2.3
3	*5965.00	107.2 PK			1.08 H	293	66.7	40.5
4	*5965.00	96.1 AV			1.08 H	293	55.6	40.5
5	11930.00	56.3 PK	74.0	-17.7	1.03 H	75	47.8	8.5
6	11930.00	46.0 AV	54.0	-8.0	1.03 H	75	37.5	8.5
Antenna Polarity & Test Distance : Vertical at 3 m								
No	Frequency (MHz)	Emission Level (dBuV/m)	Limit (dBuV/m)	Margin (dB)	Antenna Height (m)	Table Angle (Degree)	Raw Value (dBuV)	Correction Factor (dB/m)
1	#5925.00	76.4 PK	88.2	-11.8	1.00 V	227	74.1	2.3
2	#5925.00	65.7 AV	68.2	-2.5	1.00 V	227	63.4	2.3
3	*5965.00	115.3PK			1.00 V	227	74.8	40.5
4	*5965.00	104.5 AV			1.00 V	227	64.0	40.5
5	11910.00	55.8 PK	74.0	-18.2	1.02 V	296	47.3	8.5
6	11910.00	45.1 AV	54.0	-8.9	1.02 V	296	36.6	8.5

Remarks:

1. Emission Level(dBuV/m) = Raw Value(dBuV) + Correction Factor(dB/m)
2. Correction Factor(dB/m) = Antenna Factor(dB/m) + Cable Factor(dB) – Pre-Amplifier Factor(dB)
3. Margin value = Emission Level – Limit value
4. The other emission levels were very low against the limit.
5. " \* ": Fundamental frequency.
6. " # ": The radiated frequency is out of the restricted band.

RF Mode	TX 802.11ax (HE40)	Channel	CH 43 : 6165 MHz
Frequency Range	1GHz ~ 40GHz	Detector Function	Peak (PK) Average (AV)

**Antenna Polarity & Test Distance : Horizontal at 3 m**

No	Frequency (MHz)	Emission Level (dBuV/m)	Limit (dBuV/m)	Margin (dB)	Antenna Height (m)	Table Angle (Degree)	Raw Value (dBuV)	Correction Factor (dB/m)
1	*6165.00	106.4 PK			1.04 H	294	65.3	41.1
2	*6165.00	95.4 AV			1.04 H	294	54.3	41.1
3	12330.00	56.7 PK	74.0	-17.3	1.03 H	77	48.4	8.3
4	12330.00	45.8 AV	54.0	-8.2	1.03 H	77	37.5	8.3

**Antenna Polarity & Test Distance : Vertical at 3 m**

No	Frequency (MHz)	Emission Level (dBuV/m)	Limit (dBuV/m)	Margin (dB)	Antenna Height (m)	Table Angle (Degree)	Raw Value (dBuV)	Correction Factor (dB/m)
1	*6165.00	114.7 PK			1.00 V	229	73.6	41.1
2	*6165.00	103.7 AV			1.00 V	229	62.6	41.1
3	12330.00	54.9 PK	74.0	-19.1	1.09 V	289	46.6	8.3
4	12330.00	44.8 AV	54.0	-9.2	1.09 V	289	36.5	8.3

**Remarks:**

1. Emission Level(dBuV/m) = Raw Value(dBuV) + Correction Factor(dB/m)
2. Correction Factor(dB/m) = Antenna Factor(dB/m) + Cable Factor(dB) – Pre-Amplifier Factor(dB)
3. Margin value = Emission Level – Limit value
4. The other emission levels were very low against the limit.
5. " \* " : Fundamental frequency.

RF Mode	TX 802.11ax (HE40)	Channel	CH 91 : 6405 MHz
Frequency Range	1GHz ~ 40GHz	Detector Function	Peak (PK) Average (AV)

Antenna Polarity & Test Distance : Horizontal at 3 m								
No	Frequency (MHz)	Emission Level (dBuV/m)	Limit (dBuV/m)	Margin (dB)	Antenna Height (m)	Table Angle (Degree)	Raw Value (dBuV)	Correction Factor (dB/m)
1	*6405.00	106.1 PK			1.10 H	285	64.1	42.0
2	*6405.00	95.4 AV			1.10 H	285	53.4	42.0
3	#12810.00	56.5 PK	88.2	-31.7	1.00 H	61	47.6	8.9
4	#12810.00	46.5 AV	68.2	-21.7	1.00 H	61	37.6	8.9
Antenna Polarity & Test Distance : Vertical at 3 m								
No	Frequency (MHz)	Emission Level (dBuV/m)	Limit (dBuV/m)	Margin (dB)	Antenna Height (m)	Table Angle (Degree)	Raw Value (dBuV)	Correction Factor (dB/m)
1	*6405.00	116.6 PK			1.02 V	226	74.6	42.0
2	*6405.00	105.3 AV			1.02 V	226	63.3	42.0
3	#12810.00	56.0 PK	88.2	-32.2	1.00 V	290	47.1	8.9
4	#12810.00	45.9 AV	68.2	-22.3	1.00 V	290	37.0	8.9

Remarks:

1. Emission Level(dBuV/m) = Raw Value(dBuV) + Correction Factor(dB/m)
2. Correction Factor(dB/m) = Antenna Factor(dB/m) + Cable Factor(dB) – Pre-Amplifier Factor(dB)
3. Margin value = Emission Level – Limit value
4. The other emission levels were very low against the limit.
5. " \* ": Fundamental frequency.
6. " # ": The radiated frequency is out of the restricted band.

RF Mode	TX 802.11ax (HE40)	Channel	CH 99 : 6445 MHz
Frequency Range	1GHz ~ 40GHz	Detector Function	Peak (PK) Average (AV)

Antenna Polarity & Test Distance : Horizontal at 3 m								
No	Frequency (MHz)	Emission Level (dBuV/m)	Limit (dBuV/m)	Margin (dB)	Antenna Height (m)	Table Angle (Degree)	Raw Value (dBuV)	Correction Factor (dB/m)
1	*6445.00	109.3 PK			1.91 H	146	67.0	42.3
2	*6445.00	98.9 AV			1.91 H	146	56.6	42.3
3	#12890.00	61.8 PK	88.2	-26.4	2.01 H	231	53.1	8.7
4	#12890.00	51.3 AV	68.2	-16.9	2.01 H	231	42.6	8.7
Antenna Polarity & Test Distance : Vertical at 3 m								
No	Frequency (MHz)	Emission Level (dBuV/m)	Limit (dBuV/m)	Margin (dB)	Antenna Height (m)	Table Angle (Degree)	Raw Value (dBuV)	Correction Factor (dB/m)
1	*6445.00	114.6 PK			1.99 V	80	72.3	42.3
2	*6445.00	104.2 AV			1.99 V	80	61.9	42.3
3	#12890.00	58.2 PK	88.2	-30.0	2.02 V	288	49.5	8.7
4	#12890.00	47.8 AV	68.2	-20.4	2.02 V	288	39.1	8.7

Remarks:

1. Emission Level(dBuV/m) = Raw Value(dBuV) + Correction Factor(dB/m)
2. Correction Factor(dB/m) = Antenna Factor(dB/m) + Cable Factor(dB) – Pre-Amplifier Factor(dB)
3. Margin value = Emission Level – Limit value
4. The other emission levels were very low against the limit.
5. " \* ": Fundamental frequency.
6. " # ": The radiated frequency is out of the restricted band.

RF Mode	TX 802.11ax (HE40)	Channel	CH 107 : 6485 MHz
Frequency Range	1GHz ~ 40GHz	Detector Function	Peak (PK) Average (AV)

**Antenna Polarity & Test Distance : Horizontal at 3 m**

No	Frequency (MHz)	Emission Level (dBuV/m)	Limit (dBuV/m)	Margin (dB)	Antenna Height (m)	Table Angle (Degree)	Raw Value (dBuV)	Correction Factor (dB/m)
1	*6485.00	109.0 PK			1.89 H	147	66.6	42.4
2	*6485.00	98.2 AV			1.89 H	147	55.8	42.4
3	#12970.00	61.3 PK	88.2	-26.9	2.00 H	229	52.8	8.5
4	#12970.00	51.0 AV	68.2	-17.2	2.00 H	229	42.5	8.5

**Antenna Polarity & Test Distance : Vertical at 3 m**

No	Frequency (MHz)	Emission Level (dBuV/m)	Limit (dBuV/m)	Margin (dB)	Antenna Height (m)	Table Angle (Degree)	Raw Value (dBuV)	Correction Factor (dB/m)
1	*6485.00	114.8 PK			2.03 V	82	72.4	42.4
2	*6485.00	103.9 AV			2.03 V	82	61.5	42.4
3	#12970.00	57.7 PK	88.2	-30.5	2.05 V	291	49.2	8.5
4	#12970.00	47.4 AV	68.2	-20.8	2.05 V	291	38.9	8.5

**Remarks:**

1. Emission Level(dBuV/m) = Raw Value(dBuV) + Correction Factor(dB/m)
2. Correction Factor(dB/m) = Antenna Factor(dB/m) + Cable Factor(dB) – Pre-Amplifier Factor(dB)
3. Margin value = Emission Level – Limit value
4. The other emission levels were very low against the limit.
5. " \* ": Fundamental frequency.
6. " # ": The radiated frequency is out of the restricted band.

RF Mode	TX 802.11ax (HE40)	Channel	CH 115 : 6525 MHz
Frequency Range	1GHz ~ 40GHz	Detector Function	Peak (PK) Average (AV)

Antenna Polarity & Test Distance : Horizontal at 3 m								
No	Frequency (MHz)	Emission Level (dBuV/m)	Limit (dBuV/m)	Margin (dB)	Antenna Height (m)	Table Angle (Degree)	Raw Value (dBuV)	Correction Factor (dB/m)
1	*6525.00	109.5 PK			1.88 H	146	66.9	42.6
2	*6525.00	98.8 AV			1.88 H	146	56.2	42.6
3	#13050.00	61.7 PK	88.2	-26.5	1.99 H	233	53.3	8.4
4	#13050.00	51.0 AV	68.2	-17.2	1.99 H	233	42.6	8.4
Antenna Polarity & Test Distance : Vertical at 3 m								
No	Frequency (MHz)	Emission Level (dBuV/m)	Limit (dBuV/m)	Margin (dB)	Antenna Height (m)	Table Angle (Degree)	Raw Value (dBuV)	Correction Factor (dB/m)
1	*6525.00	114.4 PK			2.00 V	79	71.8	42.6
2	*6525.00	104.0 AV			2.00 V	79	61.4	42.6
3	#13050.00	57.4 PK	88.2	-30.8	2.05 V	294	49.0	8.4
4	#13050.00	47.2 AV	68.2	-21.0	2.05 V	294	38.8	8.4

Remarks:

1. Emission Level(dBuV/m) = Raw Value(dBuV) + Correction Factor(dB/m)
2. Correction Factor(dB/m) = Antenna Factor(dB/m) + Cable Factor(dB) – Pre-Amplifier Factor(dB)
3. Margin value = Emission Level – Limit value
4. The other emission levels were very low against the limit.
5. " \* ": Fundamental frequency.
6. " # ": The radiated frequency is out of the restricted band.

RF Mode	TX 802.11ax (HE40)	Channel	CH 123 : 6565 MHz
Frequency Range	1GHz ~ 40GHz	Detector Function	Peak (PK) Average (AV)

Antenna Polarity & Test Distance : Horizontal at 3 m								
No	Frequency (MHz)	Emission Level (dBuV/m)	Limit (dBuV/m)	Margin (dB)	Antenna Height (m)	Table Angle (Degree)	Raw Value (dBuV)	Correction Factor (dB/m)
1	*6565.00	108.1 PK			1.90 H	147	65.4	42.7
2	*6565.00	98.1 AV			1.90 H	147	55.4	42.7
3	#13130.00	58.4 PK	88.2	-29.8	2.02 H	201	50.0	8.4
4	#13130.00	48.4 AV	68.2	-19.8	2.02 H	201	40.0	8.4
Antenna Polarity & Test Distance : Vertical at 3 m								
No	Frequency (MHz)	Emission Level (dBuV/m)	Limit (dBuV/m)	Margin (dB)	Antenna Height (m)	Table Angle (Degree)	Raw Value (dBuV)	Correction Factor (dB/m)
1	*6565.00	114.3 PK			2.01 V	68	71.6	42.7
2	*6565.00	103.3 AV			2.01 V	68	60.6	42.7
3	#13130.00	57.9 PK	88.2	-30.3	2.05 V	219	49.5	8.4
4	#13130.00	48.3 AV	68.2	-19.9	2.05 V	219	39.9	8.4

Remarks:

1. Emission Level(dBuV/m) = Raw Value(dBuV) + Correction Factor(dB/m)
2. Correction Factor(dB/m) = Antenna Factor(dB/m) + Cable Factor(dB) – Pre-Amplifier Factor(dB)
3. Margin value = Emission Level – Limit value
4. The other emission levels were very low against the limit.
5. " \* ": Fundamental frequency.
6. " # ": The radiated frequency is out of the restricted band.

RF Mode	TX 802.11ax (HE40)	Channel	CH 155 : 6725 MHz
Frequency Range	1GHz ~ 40GHz	Detector Function	Peak (PK) Average (AV)

Antenna Polarity & Test Distance : Horizontal at 3 m								
No	Frequency (MHz)	Emission Level (dBuV/m)	Limit (dBuV/m)	Margin (dB)	Antenna Height (m)	Table Angle (Degree)	Raw Value (dBuV)	Correction Factor (dB/m)
1	*6725.00	107.7 PK			1.91 H	148	64.8	42.9
2	*6725.00	98.1 AV			1.91 H	148	55.2	42.9
3	#13450.00	59.1 PK	88.2	-29.1	2.00 H	205	50.3	8.8
4	#13450.00	48.7 AV	68.2	-19.5	2.00 H	205	39.9	8.8
Antenna Polarity & Test Distance : Vertical at 3 m								
No	Frequency (MHz)	Emission Level (dBuV/m)	Limit (dBuV/m)	Margin (dB)	Antenna Height (m)	Table Angle (Degree)	Raw Value (dBuV)	Correction Factor (dB/m)
1	*6725.00	114.2 PK			2.00 V	70	71.3	42.9
2	*6725.00	103.6 AV			2.00 V	70	60.7	42.9
3	#13450.00	58.1 PK	88.2	-30.1	2.04 V	225	49.3	8.8
4	#13450.00	48.4 AV	68.2	-19.8	2.04 V	225	39.6	8.8

Remarks:

1. Emission Level(dBuV/m) = Raw Value(dBuV) + Correction Factor(dB/m)
2. Correction Factor(dB/m) = Antenna Factor(dB/m) + Cable Factor(dB) – Pre-Amplifier Factor(dB)
3. Margin value = Emission Level – Limit value
4. The other emission levels were very low against the limit.
5. " \* " : Fundamental frequency.
6. " # " : The radiated frequency is out of the restricted band.



RF Mode	TX 802.11ax (HE40)	Channel	CH 179 : 6845 MHz
Frequency Range	1GHz ~ 40GHz	Detector Function	Peak (PK) Average (AV)

Antenna Polarity & Test Distance : Horizontal at 3 m								
No	Frequency (MHz)	Emission Level (dBuV/m)	Limit (dBuV/m)	Margin (dB)	Antenna Height (m)	Table Angle (Degree)	Raw Value (dBuV)	Correction Factor (dB/m)
1	*6845.00	108.5 PK			1.93 H	150	65.3	43.2
2	*6845.00	98.8 AV			1.93 H	150	55.6	43.2
3	#13690.00	59.1 PK	88.2	-29.1	2.00 H	205	50.2	8.9
4	#13690.00	49.1 AV	68.2	-19.1	2.00 H	205	40.2	8.9
Antenna Polarity & Test Distance : Vertical at 3 m								
No	Frequency (MHz)	Emission Level (dBuV/m)	Limit (dBuV/m)	Margin (dB)	Antenna Height (m)	Table Angle (Degree)	Raw Value (dBuV)	Correction Factor (dB/m)
1	*6845.00	114.0 PK			2.02 V	74	70.8	43.2
2	*6845.00	103.0 AV			2.02 V	74	59.8	43.2
3	#13690.00	58.6 PK	88.2	-29.6	2.01 V	223	49.7	8.9
4	#13690.00	48.5 AV	68.2	-19.7	2.01 V	223	39.6	8.9

Remarks:

1. Emission Level(dBuV/m) = Raw Value(dBuV) + Correction Factor(dB/m)
2. Correction Factor(dB/m) = Antenna Factor(dB/m) + Cable Factor(dB) – Pre-Amplifier Factor(dB)
3. Margin value = Emission Level – Limit value
4. The other emission levels were very low against the limit.
5. " \* " : Fundamental frequency.
6. " # " : The radiated frequency is out of the restricted band.

RF Mode	TX 802.11ax (HE40)	Channel	CH 187 : 6885 MHz
Frequency Range	1GHz ~ 40GHz	Detector Function	Peak (PK) Average (AV)

Antenna Polarity & Test Distance : Horizontal at 3 m								
No	Frequency (MHz)	Emission Level (dBuV/m)	Limit (dBuV/m)	Margin (dB)	Antenna Height (m)	Table Angle (Degree)	Raw Value (dBuV)	Correction Factor (dB/m)
1	*6885.00	105.6 PK			2.20 H	138	62.3	43.3
2	*6885.00	95.7 AV			2.20 H	138	52.4	43.3
3	#7125.00	60.3 PK	88.2	-27.9	2.20 H	138	54.1	6.2
4	#7125.00	49.1 AV	68.2	-19.1	2.20 H	138	42.9	6.2
5	#13770.00	60.4 PK	88.2	-27.8	3.34 H	58	51.3	9.1
6	#13770.00	51.2 AV	68.2	-17.0	3.34 H	58	42.1	9.1
Antenna Polarity & Test Distance : Vertical at 3 m								
No	Frequency (MHz)	Emission Level (dBuV/m)	Limit (dBuV/m)	Margin (dB)	Antenna Height (m)	Table Angle (Degree)	Raw Value (dBuV)	Correction Factor (dB/m)
1	*6885.00	111.7 PK			1.72 V	233	68.4	43.3
2	*6885.00	100.8 AV			1.72 V	233	57.5	43.3
3	#7125.00	60.7 PK	88.2	-27.5	1.72 V	233	54.5	6.2
4	#7125.00	49.4 AV	68.2	-18.8	1.72 V	233	43.2	6.2
5	#13770.00	59.7 PK	88.2	-28.5	3.21 V	213	50.6	9.1
6	#13770.00	49.6 AV	68.2	-18.6	3.21 V	213	40.5	9.1

Remarks:

1. Emission Level(dBuV/m) = Raw Value(dBuV) + Correction Factor(dB/m)
2. Correction Factor(dB/m) = Antenna Factor(dB/m) + Cable Factor(dB) – Pre-Amplifier Factor(dB)
3. Margin value = Emission Level – Limit value
4. The other emission levels were very low against the limit.
5. " \* " : Fundamental frequency.
6. " # " : The radiated frequency is out of the restricted band.

RF Mode	TX 802.11ax (HE40)	Channel	CH 211 : 7005 MHz
Frequency Range	1GHz ~ 40GHz	Detector Function	Peak (PK) Average (AV)

Antenna Polarity & Test Distance : Horizontal at 3 m								
No	Frequency (MHz)	Emission Level (dBuV/m)	Limit (dBuV/m)	Margin (dB)	Antenna Height (m)	Table Angle (Degree)	Raw Value (dBuV)	Correction Factor (dB/m)
1	*7005.00	106.4 PK			3.16 H	148	62.4	44.0
2	*7005.00	95.4 AV			3.16 H	148	51.4	44.0
3	#7125.00	66.6 PK	88.2	-21.6	3.16 H	148	60.4	6.2
4	#7125.00	54.5 AV	68.2	-13.7	3.16 H	148	48.3	6.2
5	7263.12	60.9 PK	74.0	-13.1	3.16 H	148	54.4	6.5
6	7263.12	49.6 AV	54.0	-4.4	3.16 H	148	43.1	6.5
7	#14010.00	60.2 PK	88.2	-28.0	3.34 H	55	50.3	9.9
8	#14010.00	50.5 AV	68.2	-17.7	3.34 H	55	40.6	9.9
Antenna Polarity & Test Distance : Vertical at 3 m								
No	Frequency (MHz)	Emission Level (dBuV/m)	Limit (dBuV/m)	Margin (dB)	Antenna Height (m)	Table Angle (Degree)	Raw Value (dBuV)	Correction Factor (dB/m)
1	*7005.00	113.2 PK			1.81 V	232	69.2	44.0
2	*7005.00	101.3 AV			1.81 V	232	57.3	44.0
3	#7125.00	74.0 PK	88.2	-14.2	1.81 V	232	67.8	6.2
4	#7125.00	60.8 AV	68.2	-7.4	1.81 V	232	54.6	6.2
5	7263.12	67.6 PK	74.0	-6.4	1.81 V	232	61.1	6.5
6	7263.12	52.9 AV	54.0	-1.1	1.81 V	232	46.4	6.5
7	#14010.00	59.8 PK	88.2	-28.4	3.20 V	211	49.9	9.9
8	#14010.00	49.7 AV	68.2	-18.5	3.20 V	211	39.8	9.9

Remarks:

1. Emission Level(dBuV/m) = Raw Value(dBuV) + Correction Factor(dB/m)
2. Correction Factor(dB/m) = Antenna Factor(dB/m) + Cable Factor(dB) – Pre-Amplifier Factor(dB)
3. Margin value = Emission Level – Limit value
4. The other emission levels were very low against the limit.
5. " \* ": Fundamental frequency.
6. " # ": The radiated frequency is out of the restricted band.

RF Mode	TX 802.11ax (HE40)	Channel	CH 227 : 7085 MHz
Frequency Range	1GHz ~ 40GHz	Detector Function	Peak (PK) Average (AV)

Antenna Polarity & Test Distance : Horizontal at 3 m								
No	Frequency (MHz)	Emission Level (dBuV/m)	Limit (dBuV/m)	Margin (dB)	Antenna Height (m)	Table Angle (Degree)	Raw Value (dBuV)	Correction Factor (dB/m)
1	*7085.00	107.9 PK			3.36 H	153	63.3	44.6
2	*7085.00	97.0 AV			3.36 H	153	52.4	44.6
3	#7125.00	76.3 PK	88.2	-11.9	3.36 H	153	70.1	6.2
4	#7125.00	65.5 AV	68.2	-2.7	3.36 H	153	59.3	6.2
5	#14170.00	61.0 PK	88.2	-27.2	3.31 H	52	50.8	10.2
6	#14170.00	50.8 AV	68.2	-17.4	3.31 H	52	40.6	10.2
Antenna Polarity & Test Distance : Vertical at 3 m								
No	Frequency (MHz)	Emission Level (dBuV/m)	Limit (dBuV/m)	Margin (dB)	Antenna Height (m)	Table Angle (Degree)	Raw Value (dBuV)	Correction Factor (dB/m)
1	*7085.00	111.9 PK			1.66 V	246	67.3	44.6
2	*7085.00	102.1 AV			1.66 V	246	57.5	44.6
3	#7125.00	77.7 PK	88.2	-10.5	1.47 V	243	71.5	6.2
4	#7125.00	67.6 AV	68.2	-0.6	1.47 V	243	61.4	6.2
5	#14170.00	60.8 PK	88.2	-27.4	3.18 V	215	50.6	10.2
6	#14170.00	51.0 AV	68.2	-17.2	3.18 V	215	40.8	10.2

Remarks:

1. Emission Level(dBuV/m) = Raw Value(dBuV) + Correction Factor(dB/m)
2. Correction Factor(dB/m) = Antenna Factor(dB/m) + Cable Factor(dB) – Pre-Amplifier Factor(dB)
3. Margin value = Emission Level – Limit value
4. The other emission levels were very low against the limit.
5. " \* " : Fundamental frequency.
6. " # " : The radiated frequency is out of the restricted band.

**802.11ax (HE80)**

RF Mode	TX 802.11ax (HE80)	Channel	CH 7 : 5985 MHz
Frequency Range	1GHz ~ 40GHz	Detector Function	Peak (PK) Average (AV)

**Antenna Polarity & Test Distance : Horizontal at 3 m**

No	Frequency (MHz)	Emission Level (dBuV/m)	Limit (dBuV/m)	Margin (dB)	Antenna Height (m)	Table Angle (Degree)	Raw Value (dBuV)	Correction Factor (dB/m)
1	#5925.00	67.6 PK	88.2	-20.6	1.13 H	295	65.3	2.3
2	#5925.00	56.5 AV	68.2	-11.7	1.13 H	295	54.2	2.3
3	*5985.00	103.0 PK			1.13 H	295	62.4	40.6
4	*5985.00	93.5 AV			1.13 H	295	52.9	40.6
5	11970.00	56.9 PK	74.0	-17.1	1.00 H	66	48.3	8.6
6	11970.00	45.7 AV	54.0	-8.3	1.00 H	66	37.1	8.6

**Antenna Polarity & Test Distance : Vertical at 3 m**

No	Frequency (MHz)	Emission Level (dBuV/m)	Limit (dBuV/m)	Margin (dB)	Antenna Height (m)	Table Angle (Degree)	Raw Value (dBuV)	Correction Factor (dB/m)
1	#5925.00	75.9 PK	88.2	-12.3	1.00 V	227	73.6	2.3
2	#5925.00	64.4 AV	68.2	-3.8	1.00 V	227	62.1	2.3
3	*5985.00	112.1 PK			1.00 V	227	71.5	40.6
4	*5985.00	101.5 AV			1.00 V	227	60.9	40.6
5	11970.00	56.2 PK	74.0	-17.8	1.05 V	287	47.6	8.6
6	11970.00	45.3 AV	54.0	-8.7	1.05 V	287	36.7	8.6

**Remarks:**

1. Emission Level(dBuV/m) = Raw Value(dBuV) + Correction Factor(dB/m)
2. Correction Factor(dB/m) = Antenna Factor(dB/m) + Cable Factor(dB) – Pre-Amplifier Factor(dB)
3. Margin value = Emission Level – Limit value
4. The other emission levels were very low against the limit.
5. " \* ": Fundamental frequency.
6. " # ": The radiated frequency is out of the restricted band.

RF Mode	TX 802.11ax (HE80)	Channel	CH 39 : 6145 MHz
Frequency Range	1GHz ~ 40GHz	Detector Function	Peak (PK) Average (AV)

**Antenna Polarity & Test Distance : Horizontal at 3 m**

No	Frequency (MHz)	Emission Level (dBuV/m)	Limit (dBuV/m)	Margin (dB)	Antenna Height (m)	Table Angle (Degree)	Raw Value (dBuV)	Correction Factor (dB/m)
1	*6145.00	102.5 PK			1.06 H	296	61.5	41.0
2	*6145.00	92.3 AV			1.06 H	296	51.3	41.0
3	12290.00	56.2 PK	74.0	-17.8	1.04 H	68	47.9	8.3
4	12290.00	45.9 AV	54.0	-8.1	1.04 H	68	37.6	8.3

**Antenna Polarity & Test Distance : Vertical at 3 m**

No	Frequency (MHz)	Emission Level (dBuV/m)	Limit (dBuV/m)	Margin (dB)	Antenna Height (m)	Table Angle (Degree)	Raw Value (dBuV)	Correction Factor (dB/m)
1	*6145.00	111.5 PK			1.00 V	225	70.5	41.0
2	*6145.00	101.2 AV			1.00 V	225	60.2	41.0
3	12290.00	54.8 PK	74.0	-19.2	1.02 V	291	46.5	8.3
4	12290.00	44.7 AV	54.0	-9.3	1.02 V	291	36.4	8.3

**Remarks:**

1. Emission Level(dBuV/m) = Raw Value(dBuV) + Correction Factor(dB/m)
2. Correction Factor(dB/m) = Antenna Factor(dB/m) + Cable Factor(dB) – Pre-Amplifier Factor(dB)
3. Margin value = Emission Level – Limit value
4. The other emission levels were very low against the limit.
5. " \* " : Fundamental frequency.

RF Mode	TX 802.11ax (HE80)	Channel	CH 87 : 6385 MHz
Frequency Range	1GHz ~ 40GHz	Detector Function	Peak (PK) Average (AV)

Antenna Polarity & Test Distance : Horizontal at 3 m								
No	Frequency (MHz)	Emission Level (dBuV/m)	Limit (dBuV/m)	Margin (dB)	Antenna Height (m)	Table Angle (Degree)	Raw Value (dBuV)	Correction Factor (dB/m)
1	*6385.00	103.8 PK			1.10 H	293	62.0	41.8
2	*6385.00	94.1 AV			1.10 H	293	52.3	41.8
3	#12770.00	56.6 PK	88.2	-31.6	1.00 H	71	47.8	8.8
4	#12770.00	46.2 AV	68.2	-22.0	1.00 H	71	37.4	8.8
Antenna Polarity & Test Distance : Vertical at 3 m								
No	Frequency (MHz)	Emission Level (dBuV/m)	Limit (dBuV/m)	Margin (dB)	Antenna Height (m)	Table Angle (Degree)	Raw Value (dBuV)	Correction Factor (dB/m)
1	*6385.00	111.6 PK			1.10 V	224	69.8	41.8
2	*6385.00	100.7 AV			1.10 V	224	58.9	41.8
3	#12770.00	55.8 PK	88.2	-32.4	1.00 V	289	47.0	8.8
4	#12770.00	45.6 AV	68.2	-22.6	1.00 V	289	36.8	8.8

Remarks:

1. Emission Level(dBuV/m) = Raw Value(dBuV) + Correction Factor(dB/m)
2. Correction Factor(dB/m) = Antenna Factor(dB/m) + Cable Factor(dB) – Pre-Amplifier Factor(dB)
3. Margin value = Emission Level – Limit value
4. The other emission levels were very low against the limit.
5. " \* ": Fundamental frequency.
6. " # ": The radiated frequency is out of the restricted band.

RF Mode	TX 802.11ax (HE80)	Channel	CH 103 : 6465 MHz
Frequency Range	1GHz ~ 40GHz	Detector Function	Peak (PK) Average (AV)

Antenna Polarity & Test Distance : Horizontal at 3 m								
No	Frequency (MHz)	Emission Level (dBuV/m)	Limit (dBuV/m)	Margin (dB)	Antenna Height (m)	Table Angle (Degree)	Raw Value (dBuV)	Correction Factor (dB/m)
1	*6465.00	108.0 PK			1.94 H	153	65.7	42.3
2	*6465.00	97.5 AV			1.94 H	153	55.2	42.3
3	#12930.00	59.4 PK	88.2	-28.8	2.01 H	228	50.8	8.6
4	#12930.00	50.0 AV	68.2	-18.2	2.01 H	228	41.4	8.6
Antenna Polarity & Test Distance : Vertical at 3 m								
No	Frequency (MHz)	Emission Level (dBuV/m)	Limit (dBuV/m)	Margin (dB)	Antenna Height (m)	Table Angle (Degree)	Raw Value (dBuV)	Correction Factor (dB/m)
1	*6465.00	111.2 PK			2.01 V	77	68.9	42.3
2	*6465.00	100.6 AV			2.01 V	77	58.3	42.3
3	#12930.00	57.5 PK	88.2	-30.7	1.96 V	290	48.9	8.6
4	#12930.00	47.3 AV	68.2	-20.9	1.96 V	290	38.7	8.6

Remarks:

1. Emission Level(dBuV/m) = Raw Value(dBuV) + Correction Factor(dB/m)
2. Correction Factor(dB/m) = Antenna Factor(dB/m) + Cable Factor(dB) – Pre-Amplifier Factor(dB)
3. Margin value = Emission Level – Limit value
4. The other emission levels were very low against the limit.
5. " \* ": Fundamental frequency.
6. " # ": The radiated frequency is out of the restricted band.



RF Mode	TX 802.11ax (HE80)	Channel	CH 119 : 6545 MHz
Frequency Range	1GHz ~ 40GHz	Detector Function	Peak (PK) Average (AV)

**Antenna Polarity & Test Distance : Horizontal at 3 m**

No	Frequency (MHz)	Emission Level (dBuV/m)	Limit (dBuV/m)	Margin (dB)	Antenna Height (m)	Table Angle (Degree)	Raw Value (dBuV)	Correction Factor (dB/m)
1	*6545.00	108.3 PK			1.90 H	151	65.6	42.7
2	*6545.00	98.1 AV			1.90 H	151	55.4	42.7
3	#13090.00	58.9 PK	88.2	-29.3	2.00 H	226	50.6	8.3
4	#13090.00	49.3 AV	68.2	-18.9	2.00 H	226	41.0	8.3

**Antenna Polarity & Test Distance : Vertical at 3 m**

No	Frequency (MHz)	Emission Level (dBuV/m)	Limit (dBuV/m)	Margin (dB)	Antenna Height (m)	Table Angle (Degree)	Raw Value (dBuV)	Correction Factor (dB/m)
1	*6545.00	111.4 PK			2.02 V	80	68.7	42.7
2	*6545.00	101.3 AV			2.02 V	80	58.6	42.7
3	#13090.00	56.8 PK	88.2	-31.4	1.87 V	292	48.5	8.3
4	#13090.00	47.0 AV	68.2	-21.2	1.87 V	292	38.7	8.3

**Remarks:**

1. Emission Level(dBuV/m) = Raw Value(dBuV) + Correction Factor(dB/m)
2. Correction Factor(dB/m) = Antenna Factor(dB/m) + Cable Factor(dB) – Pre-Amplifier Factor(dB)
3. Margin value = Emission Level – Limit value
4. The other emission levels were very low against the limit.
5. " \* " : Fundamental frequency.
6. " # " : The radiated frequency is out of the restricted band.

RF Mode	TX 802.11ax (HE80)	Channel	CH 135 : 6625 MHz
Frequency Range	1GHz ~ 40GHz	Detector Function	Peak (PK) Average (AV)

**Antenna Polarity & Test Distance : Horizontal at 3 m**

No	Frequency (MHz)	Emission Level (dBuV/m)	Limit (dBuV/m)	Margin (dB)	Antenna Height (m)	Table Angle (Degree)	Raw Value (dBuV)	Correction Factor (dB/m)
1	*6625.00	107.2 PK			1.90 H	152	64.4	42.8
2	*6625.00	95.6 AV			1.90 H	152	52.8	42.8
3	13250.00	59.1 PK	74.0	-14.9	1.95 H	325	50.5	8.6
4	13250.00	47.7 AV	54.0	-6.3	1.95 H	325	39.1	8.6

**Antenna Polarity & Test Distance : Vertical at 3 m**

No	Frequency (MHz)	Emission Level (dBuV/m)	Limit (dBuV/m)	Margin (dB)	Antenna Height (m)	Table Angle (Degree)	Raw Value (dBuV)	Correction Factor (dB/m)
1	*6625.00	110.1 PK			2.01 V	69	67.3	42.8
2	*6625.00	101.2 AV			2.01 V	69	58.4	42.8
3	13250.00	57.5 PK	74.0	-16.5	2.00 V	209	48.9	8.6
4	13250.00	46.3 AV	54.0	-7.7	2.00 V	209	37.7	8.6

**Remarks:**

1. Emission Level(dBuV/m) = Raw Value(dBuV) + Correction Factor(dB/m)
2. Correction Factor(dB/m) = Antenna Factor(dB/m) + Cable Factor(dB) – Pre-Amplifier Factor(dB)
3. Margin value = Emission Level – Limit value
4. The other emission levels were very low against the limit.
5. " \* " : Fundamental frequency.

RF Mode	TX 802.11ax (HE80)	Channel	CH 151 : 6705 MHz
Frequency Range	1GHz ~ 40GHz	Detector Function	Peak (PK) Average (AV)

Antenna Polarity & Test Distance : Horizontal at 3 m								
No	Frequency (MHz)	Emission Level (dBuV/m)	Limit (dBuV/m)	Margin (dB)	Antenna Height (m)	Table Angle (Degree)	Raw Value (dBuV)	Correction Factor (dB/m)
1	*6705.00	106.7 PK			1.91 H	147	63.8	42.9
2	*6705.00	95.4 AV			1.91 H	147	52.5	42.9
3	#13410.00	58.8 PK	88.2	-29.4	1.98 H	322	50.0	8.8
4	#13410.00	48.0 AV	68.2	-20.2	1.98 H	322	39.2	8.8
Antenna Polarity & Test Distance : Vertical at 3 m								
No	Frequency (MHz)	Emission Level (dBuV/m)	Limit (dBuV/m)	Margin (dB)	Antenna Height (m)	Table Angle (Degree)	Raw Value (dBuV)	Correction Factor (dB/m)
1	*6705.00	110.4 PK			2.04 V	71	67.5	42.9
2	*6705.00	101.4 AV			2.04 V	71	58.5	42.9
3	#13410.00	57.4 PK	88.2	-30.8	2.00 V	208	48.6	8.8
4	#13410.00	46.6 AV	68.2	-21.6	2.00 V	208	37.8	8.8

Remarks:

1. Emission Level(dBuV/m) = Raw Value(dBuV) + Correction Factor(dB/m)
2. Correction Factor(dB/m) = Antenna Factor(dB/m) + Cable Factor(dB) – Pre-Amplifier Factor(dB)
3. Margin value = Emission Level – Limit value
4. The other emission levels were very low against the limit.
5. " \* ": Fundamental frequency.
6. " # ": The radiated frequency is out of the restricted band.

RF Mode	TX 802.11ax (HE80)	Channel	CH 167 : 6785 MHz
Frequency Range	1GHz ~ 40GHz	Detector Function	Peak (PK) Average (AV)

**Antenna Polarity & Test Distance : Horizontal at 3 m**

No	Frequency (MHz)	Emission Level (dBuV/m)	Limit (dBuV/m)	Margin (dB)	Antenna Height (m)	Table Angle (Degree)	Raw Value (dBuV)	Correction Factor (dB/m)
1	*6785.00	106.4 PK			1.93 H	155	63.4	43.0
2	*6785.00	94.9 AV			1.93 H	155	51.9	43.0
3	#13570.00	59.4 PK	88.2	-28.8	1.96 H	298	50.6	8.8
4	#13570.00	47.8 AV	68.2	-20.4	1.96 H	298	39.0	8.8

**Antenna Polarity & Test Distance : Vertical at 3 m**

No	Frequency (MHz)	Emission Level (dBuV/m)	Limit (dBuV/m)	Margin (dB)	Antenna Height (m)	Table Angle (Degree)	Raw Value (dBuV)	Correction Factor (dB/m)
1	*6785.00	109.9 PK			2.00 V	68	66.9	43.0
2	*6785.00	101.5 AV			2.00 V	68	58.5	43.0
3	#13570.00	57.5 PK	88.2	-30.7	2.04 V	210	48.7	8.8
4	#13570.00	46.6 AV	68.2	-21.6	2.04 V	210	37.8	8.8

**Remarks:**

1. Emission Level(dBuV/m) = Raw Value(dBuV) + Correction Factor(dB/m)
2. Correction Factor(dB/m) = Antenna Factor(dB/m) + Cable Factor(dB) – Pre-Amplifier Factor(dB)
3. Margin value = Emission Level – Limit value
4. The other emission levels were very low against the limit.
5. " \* " : Fundamental frequency.
6. " # " : The radiated frequency is out of the restricted band.

RF Mode	TX 802.11ax (HE80)	Channel	CH 183 : 6865 MHz
Frequency Range	1GHz ~ 40GHz	Detector Function	Peak (PK) Average (AV)

Antenna Polarity & Test Distance : Horizontal at 3 m								
No	Frequency (MHz)	Emission Level (dBuV/m)	Limit (dBuV/m)	Margin (dB)	Antenna Height (m)	Table Angle (Degree)	Raw Value (dBuV)	Correction Factor (dB/m)
1	*6865.00	107.8 PK			1.89 H	149	64.5	43.3
2	*6865.00	96.3 AV			1.89 H	149	53.0	43.3
3	#13730.00	59.2 PK	88.2	-29.0	1.94 H	297	50.1	9.1
4	#13730.00	48.1 AV	68.2	-20.1	1.94 H	297	39.0	9.1
Antenna Polarity & Test Distance : Vertical at 3 m								
No	Frequency (MHz)	Emission Level (dBuV/m)	Limit (dBuV/m)	Margin (dB)	Antenna Height (m)	Table Angle (Degree)	Raw Value (dBuV)	Correction Factor (dB/m)
1	*6865.00	110.8 PK			2.03 V	68	67.5	43.3
2	*6865.00	101.2 AV			2.03 V	68	57.9	43.3
3	#13730.00	57.8 PK	88.2	-30.4	2.06 V	211	48.7	9.1
4	#13730.00	47.1 AV	68.2	-21.1	2.06 V	211	38.0	9.1

Remarks:

1. Emission Level(dBuV/m) = Raw Value(dBuV) + Correction Factor(dB/m)
2. Correction Factor(dB/m) = Antenna Factor(dB/m) + Cable Factor(dB) – Pre-Amplifier Factor(dB)
3. Margin value = Emission Level – Limit value
4. The other emission levels were very low against the limit.
5. " \* " : Fundamental frequency.
6. " # " : The radiated frequency is out of the restricted band.

RF Mode	TX 802.11ax (HE80)	Channel	CH 199 : 6945 MHz
Frequency Range	1GHz ~ 40GHz	Detector Function	Peak (PK) Average (AV)

Antenna Polarity & Test Distance : Horizontal at 3 m								
No	Frequency (MHz)	Emission Level (dBuV/m)	Limit (dBuV/m)	Margin (dB)	Antenna Height (m)	Table Angle (Degree)	Raw Value (dBuV)	Correction Factor (dB/m)
1	*6945.00	102.2 PK			3.06 H	144	58.3	43.9
2	*6945.00	92.4 AV			3.06 H	144	48.5	43.9
3	7258.70	60.7 PK	74.0	-13.3	3.06 H	144	54.2	6.5
4	7258.70	49.6 AV	54.0	-4.4	3.06 H	144	43.1	6.5
5	#13890.00	61.2 PK	88.2	-27.0	3.30 H	57	51.7	9.5
6	#13890.00	51.0 AV	68.2	-17.2	3.30 H	57	41.5	9.5
Antenna Polarity & Test Distance : Vertical at 3 m								
No	Frequency (MHz)	Emission Level (dBuV/m)	Limit (dBuV/m)	Margin (dB)	Antenna Height (m)	Table Angle (Degree)	Raw Value (dBuV)	Correction Factor (dB/m)
1	*6945.00	110.2 PK			1.68 V	228	66.3	43.9
2	*6945.00	98.7 AV			1.68 V	228	54.8	43.9
3	7258.70	64.9 PK	74.0	-9.1	1.68 V	228	58.4	6.5
4	7258.70	52.6 AV	54.0	-1.4	1.68 V	228	46.1	6.5
5	#13890.00	60.0 PK	88.2	-28.2	3.25 V	216	50.5	9.5
6	#13890.00	49.5 AV	68.2	-18.7	3.25 V	216	40.0	9.5

Remarks:

1. Emission Level(dBuV/m) = Raw Value(dBuV) + Correction Factor(dB/m)
2. Correction Factor(dB/m) = Antenna Factor(dB/m) + Cable Factor(dB) – Pre-Amplifier Factor(dB)
3. Margin value = Emission Level – Limit value
4. The other emission levels were very low against the limit.
5. " \* " : Fundamental frequency.
6. " # " : The radiated frequency is out of the restricted band.

RF Mode	TX 802.11ax (HE80)	Channel	CH 215 : 7025 MHz
Frequency Range	1GHz ~ 40GHz	Detector Function	Peak (PK) Average (AV)

Antenna Polarity & Test Distance : Horizontal at 3 m								
No	Frequency (MHz)	Emission Level (dBuV/m)	Limit (dBuV/m)	Margin (dB)	Antenna Height (m)	Table Angle (Degree)	Raw Value (dBuV)	Correction Factor (dB/m)
1	*7025.00	102.6 PK			3.14 H	148	58.5	44.1
2	*7025.00	90.2 AV			3.14 H	148	46.1	44.1
3	#7125.00	61.4 PK	88.2	-26.8	3.14 H	148	55.2	6.2
4	#7125.00	49.7 AV	68.2	-18.5	3.14 H	148	43.5	6.2
5	#14050.00	60.5 PK	88.2	-27.7	3.33 H	48	50.6	9.9
6	#14050.00	50.5 AV	68.2	-17.7	3.33 H	48	40.6	9.9
Antenna Polarity & Test Distance : Vertical at 3 m								
No	Frequency (MHz)	Emission Level (dBuV/m)	Limit (dBuV/m)	Margin (dB)	Antenna Height (m)	Table Angle (Degree)	Raw Value (dBuV)	Correction Factor (dB/m)
1	*7025.00	106.9 PK			1.76 V	230	62.8	44.1
2	*7025.00	96.7 AV			1.76 V	230	52.6	44.1
3	#7125.00	64.8 PK	88.2	-23.4	1.76 V	230	58.6	6.2
4	#7125.00	54.5 AV	68.2	-13.7	1.76 V	230	48.3	6.2
5	#14050.00	59.7 PK	88.2	-28.5	3.17 V	210	49.8	9.9
6	#14050.00	49.7 AV	68.2	-18.5	3.17 V	210	39.8	9.9

Remarks:

1. Emission Level(dBuV/m) = Raw Value(dBuV) + Correction Factor(dB/m)
2. Correction Factor(dB/m) = Antenna Factor(dB/m) + Cable Factor(dB) – Pre-Amplifier Factor(dB)
3. Margin value = Emission Level – Limit value
4. The other emission levels were very low against the limit.
5. " \* " : Fundamental frequency.
6. " # " : The radiated frequency is out of the restricted band.

### 802.11ax (HE160)

RF Mode	TX 802.11ax (HE160)	Channel	CH 15 : 6025 MHz
Frequency Range	1GHz ~ 40GHz	Detector Function	Peak (PK) Average (AV)

#### Antenna Polarity & Test Distance : Horizontal at 3 m

No	Frequency (MHz)	Emission Level (dBuV/m)	Limit (dBuV/m)	Margin (dB)	Antenna Height (m)	Table Angle (Degree)	Raw Value (dBuV)	Correction Factor (dB/m)
1	#5925.00	65.3 PK	88.2	-22.9	1.46 H	94	61.8	3.5
2	#5925.00	52.7 AV	68.2	-15.5	1.46 H	94	49.2	3.5
3	*6025.00	102.7 PK			1.46 H	94	60.8	41.9
4	*6025.00	92.8 AV			1.46 H	94	50.9	41.9
5	12050.00	56.3 PK	74.0	-17.7	1.03 H	85	48.6	7.7
6	12050.00	46.1 AV	54.0	-7.9	1.03 H	85	38.4	7.7

#### Antenna Polarity & Test Distance : Vertical at 3 m

No	Frequency (MHz)	Emission Level (dBuV/m)	Limit (dBuV/m)	Margin (dB)	Antenna Height (m)	Table Angle (Degree)	Raw Value (dBuV)	Correction Factor (dB/m)
1	#5925.00	61.4 PK	88.2	-26.8	1.84 V	190	57.9	3.5
2	#5925.00	50.6 AV	68.2	-17.6	1.84 V	190	47.1	3.5
3	*6025.00	98.8 PK			1.84 V	190	56.9	41.9
4	*6025.00	88.9 AV			1.84 V	190	47.0	41.9
5	12050.00	56.2 PK	74.0	-17.8	1.28 V	263	48.5	7.7
6	12050.00	45.7 AV	54.0	-8.3	1.28 V	263	38.0	7.7

#### Remarks:

1. Emission Level(dBuV/m) = Raw Value(dBuV) + Correction Factor(dB/m)
2. Correction Factor(dB/m) = Antenna Factor(dB/m) + Cable Factor(dB) – Pre-Amplifier Factor(dB)
3. Margin value = Emission Level – Limit value
4. The other emission levels were very low against the limit.
5. " \* " : Fundamental frequency.
6. " # " : The radiated frequency is out of the restricted band.



RF Mode	TX 802.11ax (HE160)	Channel	CH 47 : 6185 MHz
Frequency Range	1GHz ~ 40GHz	Detector Function	Peak (PK) Average (AV)

Antenna Polarity & Test Distance : Horizontal at 3 m								
No	Frequency (MHz)	Emission Level (dBuV/m)	Limit (dBuV/m)	Margin (dB)	Antenna Height (m)	Table Angle (Degree)	Raw Value (dBuV)	Correction Factor (dB/m)
1	*6185.00	103.0 PK			2.01 H	98	60.4	42.6
2	*6185.00	94.0 AV			2.01 H	98	51.4	42.6
3	12350.00	57.0 PK	74.0	-17.0	1.14 H	93	48.6	8.4
4	12350.00	46.8 AV	54.0	-7.2	1.14 H	93	38.4	8.4
Antenna Polarity & Test Distance : Vertical at 3 m								
No	Frequency (MHz)	Emission Level (dBuV/m)	Limit (dBuV/m)	Margin (dB)	Antenna Height (m)	Table Angle (Degree)	Raw Value (dBuV)	Correction Factor (dB/m)
1	*6185.00	100.6 PK			1.32 V	150	58.0	42.6
2	*6185.00	90.1 AV			1.32 V	150	47.5	42.6
3	12350.00	56.8 PK	74.0	-17.2	1.63 V	271	48.4	8.4
4	12350.00	46.5 AV	54.0	-7.5	1.63 V	271	38.1	8.4

Remarks:

1. Emission Level(dBuV/m) = Raw Value(dBuV) + Correction Factor(dB/m)
2. Correction Factor(dB/m) = Antenna Factor(dB/m) + Cable Factor(dB) – Pre-Amplifier Factor(dB)
3. Margin value = Emission Level – Limit value
4. The other emission levels were very low against the limit.
5. " \* ": Fundamental frequency.

RF Mode	TX 802.11ax (HE160)	Channel	CH 79 : 6345 MHz
Frequency Range	1GHz ~ 40GHz	Detector Function	Peak (PK) Average (AV)

**Antenna Polarity & Test Distance : Horizontal at 3 m**

No	Frequency (MHz)	Emission Level (dBuV/m)	Limit (dBuV/m)	Margin (dB)	Antenna Height (m)	Table Angle (Degree)	Raw Value (dBuV)	Correction Factor (dB/m)
1	*6345.00	106.7 PK			2.18 H	90	63.1	43.6
2	*6345.00	96.5 AV			2.18 H	90	52.9	43.6
3	12690.00	57.2 PK	74.0	-16.8	1.08 H	67	48.4	8.8
4	12690.00	46.9 AV	54.0	-7.1	1.08 H	67	38.1	8.8

**Antenna Polarity & Test Distance : Vertical at 3 m**

No	Frequency (MHz)	Emission Level (dBuV/m)	Limit (dBuV/m)	Margin (dB)	Antenna Height (m)	Table Angle (Degree)	Raw Value (dBuV)	Correction Factor (dB/m)
1	*6345.00	101.7 PK			1.54 V	191	58.1	43.6
2	*6345.00	91.1 AV			1.54 V	191	47.5	43.6
3	12690.00	56.6 PK	74.0	-17.4	1.50 V	249	47.8	8.8
4	12690.00	46.4 AV	54.0	-7.6	1.50 V	249	37.6	8.8

**Remarks:**

1. Emission Level(dBuV/m) = Raw Value(dBuV) + Correction Factor(dB/m)
2. Correction Factor(dB/m) = Antenna Factor(dB/m) + Cable Factor(dB) – Pre-Amplifier Factor(dB)
3. Margin value = Emission Level – Limit value
4. The other emission levels were very low against the limit.
5. " \* ": Fundamental frequency.

RF Mode	TX 802.11ax (HE160)	Channel	CH 111 : 6505 MHz
Frequency Range	1GHz ~ 40GHz	Detector Function	Peak (PK) Average (AV)

Antenna Polarity & Test Distance : Horizontal at 3 m								
No	Frequency (MHz)	Emission Level (dBuV/m)	Limit (dBuV/m)	Margin (dB)	Antenna Height (m)	Table Angle (Degree)	Raw Value (dBuV)	Correction Factor (dB/m)
1	*6505.00	108.7 PK			2.07 H	85	64.5	44.2
2	*6505.00	98.0 AV			2.07 H	85	53.8	44.2
3	#13010.00	57.9 PK	88.2	-30.3	1.12 H	69	49.0	8.9
4	#13010.00	47.5 AV	68.2	-20.7	1.12 H	69	38.6	8.9
Antenna Polarity & Test Distance : Vertical at 3 m								
No	Frequency (MHz)	Emission Level (dBuV/m)	Limit (dBuV/m)	Margin (dB)	Antenna Height (m)	Table Angle (Degree)	Raw Value (dBuV)	Correction Factor (dB/m)
1	*6505.00	105.2 PK			1.49 V	189	61.0	44.2
2	*6505.00	93.9 AV			1.49 V	189	49.7	44.2
3	#13010.00	57.2 PK	88.2	-31.0	1.35 V	257	48.3	8.9
4	#13010.00	47.3 AV	68.2	-20.9	1.35 V	257	38.4	8.9

Remarks:

1. Emission Level(dBuV/m) = Raw Value(dBuV) + Correction Factor(dB/m)
2. Correction Factor(dB/m) = Antenna Factor(dB/m) + Cable Factor(dB) – Pre-Amplifier Factor(dB)
3. Margin value = Emission Level – Limit value
4. The other emission levels were very low against the limit.
5. " \* ": Fundamental frequency.
6. " # ": The radiated frequency is out of the restricted band.

RF Mode	TX 802.11ax (HE160)	Channel	CH 143 : 6665 MHz
Frequency Range	1GHz ~ 40GHz	Detector Function	Peak (PK) Average (AV)

Antenna Polarity & Test Distance : Horizontal at 3 m								
No	Frequency (MHz)	Emission Level (dBuV/m)	Limit (dBuV/m)	Margin (dB)	Antenna Height (m)	Table Angle (Degree)	Raw Value (dBuV)	Correction Factor (dB/m)
1	*6665.00	106.3 PK			2.09 H	83	61.7	44.6
2	*6665.00	97.1 AV			2.09 H	83	52.5	44.6
3	13330.00	57.1 PK	74.0	-16.9	1.13 H	74	48.3	8.8
4	13330.00	47.0 AV	54.0	-7.0	1.13 H	74	38.2	8.8
Antenna Polarity & Test Distance : Vertical at 3 m								
No	Frequency (MHz)	Emission Level (dBuV/m)	Limit (dBuV/m)	Margin (dB)	Antenna Height (m)	Table Angle (Degree)	Raw Value (dBuV)	Correction Factor (dB/m)
1	*6665.00	103.1 PK			1.52 V	192	58.5	44.6
2	*6665.00	93.2 AV			1.52 V	192	48.6	44.6
3	13330.00	56.4 PK	74.0	-17.6	1.47 V	253	47.6	8.8
4	13330.00	46.7 AV	54.0	-7.3	1.47 V	253	37.9	8.8

Remarks:

1. Emission Level(dBuV/m) = Raw Value(dBuV) + Correction Factor(dB/m)
2. Correction Factor(dB/m) = Antenna Factor(dB/m) + Cable Factor(dB) – Pre-Amplifier Factor(dB)
3. Margin value = Emission Level – Limit value
4. The other emission levels were very low against the limit.
5. " \* " : Fundamental frequency.

RF Mode	TX 802.11ax (HE160)	Channel	CH 175 : 6825 MHz
Frequency Range	1GHz ~ 40GHz	Detector Function	Peak (PK) Average (AV)

Antenna Polarity & Test Distance : Horizontal at 3 m								
No	Frequency (MHz)	Emission Level (dBuV/m)	Limit (dBuV/m)	Margin (dB)	Antenna Height (m)	Table Angle (Degree)	Raw Value (dBuV)	Correction Factor (dB/m)
1	*6825.00	106.1 PK			2.00 H	80	61.3	44.8
2	*6825.00	96.5 AV			2.00 H	80	51.7	44.8
3	#13650.00	57.3 PK	88.2	-30.9	1.09 H	66	48.7	8.6
4	#13650.00	46.9 AV	68.2	-21.3	1.09 H	66	38.3	8.6
Antenna Polarity & Test Distance : Vertical at 3 m								
No	Frequency (MHz)	Emission Level (dBuV/m)	Limit (dBuV/m)	Margin (dB)	Antenna Height (m)	Table Angle (Degree)	Raw Value (dBuV)	Correction Factor (dB/m)
1	*6825.00	102.2 PK			1.51 V	195	57.4	44.8
2	*6825.00	92.6 AV			1.51 V	195	47.8	44.8
3	#13650.00	57.1 PK	88.2	-31.1	1.38 V	258	48.5	8.6
4	#13650.00	46.7 AV	68.2	-21.5	1.38 V	258	38.1	8.6

Remarks:

1. Emission Level(dBuV/m) = Raw Value(dBuV) + Correction Factor(dB/m)
2. Correction Factor(dB/m) = Antenna Factor(dB/m) + Cable Factor(dB) – Pre-Amplifier Factor(dB)
3. Margin value = Emission Level – Limit value
4. The other emission levels were very low against the limit.
5. " \* ": Fundamental frequency.
6. " # ": The radiated frequency is out of the restricted band.

RF Mode	TX 802.11ax (HE160)	Channel	CH 207 : 6985 MHz
Frequency Range	1GHz ~ 40GHz	Detector Function	Peak (PK) Average (AV)

**Antenna Polarity & Test Distance : Horizontal at 3 m**

No	Frequency (MHz)	Emission Level (dBuV/m)	Limit (dBuV/m)	Margin (dB)	Antenna Height (m)	Table Angle (Degree)	Raw Value (dBuV)	Correction Factor (dB/m)
1	*6985.00	106.2 PK			2.29 H	79	61.2	45.0
2	*6985.00	96.5 AV			2.29 H	79	51.5	45.0
3	#7125.00	79.4 PK	88.2	-8.8	2.29 H	79	72.7	6.7
4	#7125.00	63.8 AV	68.2	-4.4	2.29 H	79	57.1	6.7
5	#13970.00	57.7 PK	88.2	-30.5	1.00 H	68	48.4	9.3
6	#13970.00	47.6 AV	68.2	-20.6	1.00 H	68	38.3	9.3

**Antenna Polarity & Test Distance : Vertical at 3 m**

No	Frequency (MHz)	Emission Level (dBuV/m)	Limit (dBuV/m)	Margin (dB)	Antenna Height (m)	Table Angle (Degree)	Raw Value (dBuV)	Correction Factor (dB/m)
1	*6985.00	102.2 PK			1.39 V	226	57.2	45.0
2	*6985.00	93.0 AV			1.39 V	226	48.0	45.0
3	#7125.00	76.8 PK	88.2	-11.4	1.39 V	226	70.1	6.7
4	#7125.00	64.1 AV	68.2	-4.1	1.39 V	226	57.4	6.7
5	#13970.00	57.2 PK	88.2	-31.0	1.34 V	264	47.9	9.3
6	#13970.00	47.3 AV	68.2	-20.9	1.34 V	264	38.0	9.3

**Remarks:**

1. Emission Level(dBuV/m) = Raw Value(dBuV) + Correction Factor(dB/m)
2. Correction Factor(dB/m) = Antenna Factor(dB/m) + Cable Factor(dB) – Pre-Amplifier Factor(dB)
3. Margin value = Emission Level – Limit value
4. The other emission levels were very low against the limit.
5. " \* " : Fundamental frequency.
6. " # " : The radiated frequency is out of the restricted band.

**RU26**

RF Mode	TX 20MHz Preamble 802.11ax (RU26/0)	Channel	CH 1 : 5955 MHz
Frequency Range	1GHz ~ 40GHz	Detector Function	Peak (PK) Average (AV)

Antenna Polarity & Test Distance : Horizontal at 3 m								
No	Frequency (MHz)	Emission Level (dBuV/m)	Limit (dBuV/m)	Margin (dB)	Antenna Height (m)	Table Angle (Degree)	Raw Value (dBuV)	Correction Factor (dB/m)
1	#5925.00	57.6 PK	88.2	-30.6	2.12 H	80	54.1	3.5
2	#5925.00	46.3 AV	68.2	-21.9	2.12 H	82	42.8	3.5
3	*5946.00	113.5 PK			2.12 H	82	71.8	41.7
4	*5946.00	104.4 AV			2.12 H	80	62.7	41.7
5	11910.00	55.8 PK	74.0	-18.2	1.03 H	75	48.2	7.6
6	11910.00	45.1 AV	54.0	-8.9	1.03 H	75	37.5	7.6

Antenna Polarity & Test Distance : Vertical at 3 m								
No	Frequency (MHz)	Emission Level (dBuV/m)	Limit (dBuV/m)	Margin (dB)	Antenna Height (m)	Table Angle (Degree)	Raw Value (dBuV)	Correction Factor (dB/m)
1	#5925.00	57.5 PK	88.2	-30.7	1.71 V	177	54.0	3.5
2	#5925.00	46.4 AV	68.2	-21.8	1.71 V	177	42.9	3.5
3	*5946.00	111.3 PK			1.71 V	177	69.6	41.7
4	*5946.00	102.1 AV			1.71 V	177	60.4	41.7
5	11910.00	55.2 PK	74.0	-18.8	1.32 V	274	47.6	7.6
6	11910.00	44.7 AV	54.0	-9.3	1.32 V	274	37.1	7.6

Remarks:

1. Emission Level(dBuV/m) = Raw Value(dBuV) + Correction Factor(dB/m)
2. Correction Factor(dB/m) = Antenna Factor(dB/m) + Cable Factor(dB) – Pre-Amplifier Factor(dB)
3. Margin value = Emission Level – Limit value
4. The other emission levels were very low against the limit.
5. " \* " : Fundamental frequency.
6. " # " : The radiated frequency is out of the restricted band.

RF Mode	TX 20MHz Preamble 802.11ax (RU52/37)	Channel	CH 1 : 5955 MHz
Frequency Range	1GHz ~ 40GHz	Detector Function	Peak (PK) Average (AV)

**Antenna Polarity & Test Distance : Horizontal at 3 m**

No	Frequency (MHz)	Emission Level (dBuV/m)	Limit (dBuV/m)	Margin (dB)	Antenna Height (m)	Table Angle (Degree)	Raw Value (dBuV)	Correction Factor (dB/m)
1	#5925.00	58.0 PK	88.2	-30.2	1.45 H	280	54.5	3.5
2	#5925.00	46.4 AV	68.2	-21.8	1.45 H	280	42.9	3.5
3	*5948.00	109.3 PK			1.45 H	280	67.6	41.7
4	*5948.00	99.9 AV			1.45 H	280	58.2	41.7
5	11910.00	54.7 PK	74.0	-19.3	1.00 H	63	47.1	7.6
6	11910.00	44.5 AV	54.0	-9.5	1.00 H	63	36.9	7.6

**Antenna Polarity & Test Distance : Vertical at 3 m**

No	Frequency (MHz)	Emission Level (dBuV/m)	Limit (dBuV/m)	Margin (dB)	Antenna Height (m)	Table Angle (Degree)	Raw Value (dBuV)	Correction Factor (dB/m)
1	#5925.00	59.5 PK	88.2	-28.7	1.48 V	185	56.0	3.5
2	#5925.00	46.4 AV	68.2	-21.8	1.48 V	185	42.9	3.5
3	*5948.00	106.8 PK			1.48 V	185	65.1	41.7
4	*5948.00	97.4 AV			1.48 V	185	55.7	41.7
5	11910.00	55.2 PK	74.0	-18.8	1.32 V	174	47.6	7.6
6	11910.00	44.7 AV	54.0	-9.3	1.32 V	174	37.1	7.6

**Remarks:**

1. Emission Level(dBuV/m) = Raw Value(dBuV) + Correction Factor(dB/m)
2. Correction Factor(dB/m) = Antenna Factor(dB/m) + Cable Factor(dB) – Pre-Amplifier Factor(dB)
3. Margin value = Emission Level – Limit value
4. The other emission levels were very low against the limit.
5. " \* " : Fundamental frequency.
6. " # " : The radiated frequency is out of the restricted band.



RF Mode	TX 20MHz Preamble 802.11ax (RU106/53)	Channel	CH 1 : 5955 MHz
Frequency Range	1GHz ~ 40GHz	Detector Function	Peak (PK) Average (AV)

**Antenna Polarity & Test Distance : Horizontal at 3 m**

No	Frequency (MHz)	Emission Level (dBuV/m)	Limit (dBuV/m)	Margin (dB)	Antenna Height (m)	Table Angle (Degree)	Raw Value (dBuV)	Correction Factor (dB/m)
1	#5925.00	57.9 PK	88.2	-30.3	1.48 H	280	54.4	3.5
2	#5925.00	46.4 AV	68.2	-21.8	1.48 H	280	42.9	3.5
3	*5948.70	108.9 PK			1.48 H	280	67.2	41.7
4	*5948.70	96.9 AV			1.48 H	280	55.2	41.7
5	11910.00	54.8 PK	74.0	-19.2	1.03 H	63	47.2	7.6
6	11910.00	44.8 AV	54.0	-9.2	1.03 H	63	37.2	7.6

**Antenna Polarity & Test Distance : Vertical at 3 m**

No	Frequency (MHz)	Emission Level (dBuV/m)	Limit (dBuV/m)	Margin (dB)	Antenna Height (m)	Table Angle (Degree)	Raw Value (dBuV)	Correction Factor (dB/m)
1	#5925.00	58.4 PK	88.2	-29.8	1.58 V	183	54.9	3.5
2	#5925.00	46.3 AV	68.2	-21.9	1.58 V	183	42.8	3.5
3	*5948.70	105.1 PK			1.58 V	183	63.4	41.7
4	*5948.70	94.9 AV			1.58 V	183	53.2	41.7
5	11910.00	54.5 PK	74.0	-19.5	1.32 V	265	46.9	7.6
6	11910.00	44.6 AV	54.0	-9.4	1.32 V	265	37.0	7.6

**Remarks:**

1. Emission Level(dBuV/m) = Raw Value(dBuV) + Correction Factor(dB/m)
2. Correction Factor(dB/m) = Antenna Factor(dB/m) + Cable Factor(dB) – Pre-Amplifier Factor(dB)
3. Margin value = Emission Level – Limit value
4. The other emission levels were very low against the limit.
5. " \* " : Fundamental frequency.
6. " # " : The radiated frequency is out of the restricted band.

RF Mode	TX 20MHz Preamble 802.11ax (RU242)	Channel	CH 1 : 5955 MHz
Frequency Range	1GHz ~ 40GHz	Detector Function	Peak (PK) Average (AV)

**Antenna Polarity & Test Distance : Horizontal at 3 m**

No	Frequency (MHz)	Emission Level (dBuV/m)	Limit (dBuV/m)	Margin (dB)	Antenna Height (m)	Table Angle (Degree)	Raw Value (dBuV)	Correction Factor (dB/m)
1	#5925.00	58.4 PK	88.2	-29.8	1.56 H	279	54.9	3.5
2	#5925.00	46.6 AV	68.2	-21.6	1.56 H	279	43.1	3.5
3	*5955.00	103.1 PK			1.56 H	279	61.4	41.7
4	*5955.00	93.0 AV			1.56 H	279	51.3	41.7
5	11910.00	55.0 PK	74.0	-19.0	1.08 H	72	47.4	7.6
6	11910.00	44.9 AV	54.0	-9.1	1.08 H	72	37.3	7.6

**Antenna Polarity & Test Distance : Vertical at 3 m**

No	Frequency (MHz)	Emission Level (dBuV/m)	Limit (dBuV/m)	Margin (dB)	Antenna Height (m)	Table Angle (Degree)	Raw Value (dBuV)	Correction Factor (dB/m)
1	#5925.00	59.6 PK	88.2	-28.6	1.56 V	183	56.1	3.5
2	#5925.00	46.2 AV	68.2	-22.0	1.56 V	183	42.7	3.5
3	*5955.00	100.9 PK			1.56 V	183	59.2	41.7
4	*5955.00	91.8 AV			1.56 V	183	50.1	41.7
5	11910.00	54.9 PK	74.0	-19.1	1.31 V	276	47.3	7.6
6	11910.00	44.8 AV	54.0	-9.2	1.31 V	276	37.2	7.6

**Remarks:**

1. Emission Level(dBuV/m) = Raw Value(dBuV) + Correction Factor(dB/m)
2. Correction Factor(dB/m) = Antenna Factor(dB/m) + Cable Factor(dB) – Pre-Amplifier Factor(dB)
3. Margin value = Emission Level – Limit value
4. The other emission levels were very low against the limit.
5. " \* " : Fundamental frequency.
6. " # " : The radiated frequency is out of the restricted band.

RF Mode	TX 20MHz Preamble 802.11ax (RU26/8)	Channel	CH 233 : 7115 MHz
Frequency Range	1GHz ~ 40GHz	Detector Function	Peak (PK) Average (AV)

Antenna Polarity & Test Distance : Horizontal at 3 m								
No	Frequency (MHz)	Emission Level (dBuV/m)	Limit (dBuV/m)	Margin (dB)	Antenna Height (m)	Table Angle (Degree)	Raw Value (dBuV)	Correction Factor (dB/m)
1	*7123.00	99.4 PK			1.56 H	293	54.2	45.2
2	*7123.00	90.3 AV			1.56 H	293	45.1	45.2
3	#7125.00	81.8 PK	88.2	-6.4	1.56 H	293	75.1	6.7
4	#7125.00	62.0 AV	68.2	-6.2	1.56 H	293	55.3	6.7
5	#14230.00	56.6 PK	88.2	-31.6	1.00 H	68	47.1	9.5
6	#14230.00	46.7 AV	68.2	-21.5	1.00 H	68	37.2	9.5

Antenna Polarity & Test Distance : Vertical at 3 m								
No	Frequency (MHz)	Emission Level (dBuV/m)	Limit (dBuV/m)	Margin (dB)	Antenna Height (m)	Table Angle (Degree)	Raw Value (dBuV)	Correction Factor (dB/m)
1	*7123.00	101.7 PK			1.41 V	232	56.5	45.2
2	*7123.00	90.7 AV			1.41 V	232	45.5	45.2
3	#7125.00	77.9 PK	88.2	-10.3	1.41 V	232	71.2	6.7
4	#7125.00	63.4 AV	68.2	-4.8	1.41 V	232	56.7	6.7
5	#14230.00	56.8 PK	88.2	-31.4	1.03 V	262	47.3	9.5
6	#14230.00	46.7 AV	68.2	-21.5	1.03 V	262	37.2	9.5

Remarks:

1. Emission Level(dBuV/m) = Raw Value(dBuV) + Correction Factor(dB/m)
2. Correction Factor(dB/m) = Antenna Factor(dB/m) + Cable Factor(dB) – Pre-Amplifier Factor(dB)
3. Margin value = Emission Level – Limit value
4. The other emission levels were very low against the limit.
5. " \* " : Fundamental frequency.
6. " # " : The radiated frequency is out of the restricted band.

RF Mode	TX 20MHz Preamble 802.11ax (RU52/40)	Channel	CH 233 : 7115 MHz
Frequency Range	1GHz ~ 40GHz	Detector Function	Peak (PK) Average (AV)

**Antenna Polarity & Test Distance : Horizontal at 3 m**

No	Frequency (MHz)	Emission Level (dBuV/m)	Limit (dBuV/m)	Margin (dB)	Antenna Height (m)	Table Angle (Degree)	Raw Value (dBuV)	Correction Factor (dB/m)
1	*7121.00	100.7 PK			1.50 H	292	55.5	45.2
2	*7121.00	91.0 AV			1.50 H	292	45.8	45.2
3	#7125.00	82.0 PK	88.2	-6.2	1.50 H	292	75.3	6.7
4	#7125.00	62.3 AV	68.2	-5.9	1.50 H	292	55.6	6.7
5	#14230.00	56.8 PK	88.2	-31.4	1.08 H	262	47.3	9.5
6	#14230.00	46.5 AV	68.2	-21.7	1.08 H	262	37.0	9.5

**Antenna Polarity & Test Distance : Vertical at 3 m**

No	Frequency (MHz)	Emission Level (dBuV/m)	Limit (dBuV/m)	Margin (dB)	Antenna Height (m)	Table Angle (Degree)	Raw Value (dBuV)	Correction Factor (dB/m)
1	*7121.00	101.4 PK			1.50 V	232	56.2	45.2
2	*7121.00	91.8 AV			1.50 V	232	46.6	45.2
3	#7125.00	84.9 PK	88.2	-3.3	1.50 V	232	78.2	6.7
4	#7125.00	64.1 AV	68.2	-4.1	1.50 V	232	57.4	6.7
5	#14230.00	57.0 PK	88.2	-31.2	1.44 V	280	47.5	9.5
6	#14230.00	46.6 AV	68.2	-21.6	1.44 V	280	37.1	9.5

**Remarks:**

1. Emission Level(dBuV/m) = Raw Value(dBuV) + Correction Factor(dB/m)
2. Correction Factor(dB/m) = Antenna Factor(dB/m) + Cable Factor(dB) – Pre-Amplifier Factor(dB)
3. Margin value = Emission Level – Limit value
4. The other emission levels were very low against the limit.
5. " \* " : Fundamental frequency.
6. " # " : The radiated frequency is out of the restricted band.

RF Mode	TX 20MHz Preamble 802.11ax (RU106/54)	Channel	CH 233 : 7115 MHz
Frequency Range	1GHz ~ 40GHz	Detector Function	Peak (PK) Average (AV)

**Antenna Polarity & Test Distance : Horizontal at 3 m**

No	Frequency (MHz)	Emission Level (dBuV/m)	Limit (dBuV/m)	Margin (dB)	Antenna Height (m)	Table Angle (Degree)	Raw Value (dBuV)	Correction Factor (dB/m)
1	*7120.00	97.4 PK			1.52 H	291	52.2	45.2
2	*7120.00	88.9 AV			1.52 H	291	43.7	45.2
3	#7125.00	78.5 PK	88.2	-9.7	1.52 H	291	71.8	6.7
4	#7125.00	64.9 AV	68.2	-3.3	1.52 H	291	58.2	6.7
5	#14230.00	56.7 PK	88.2	-31.5	1.10 H	59	47.2	9.5
6	#14230.00	46.4 AV	68.2	-21.8	1.10 H	59	36.9	9.5

**Antenna Polarity & Test Distance : Vertical at 3 m**

No	Frequency (MHz)	Emission Level (dBuV/m)	Limit (dBuV/m)	Margin (dB)	Antenna Height (m)	Table Angle (Degree)	Raw Value (dBuV)	Correction Factor (dB/m)
1	*7120.00	99.2 PK			1.53 V	230	54.0	45.2
2	*7120.00	89.4 AV			1.53 V	230	44.2	45.2
3	#7125.00	81.4 PK	88.2	-6.8	1.53 V	230	74.7	6.7
4	#7125.00	66.7 AV	68.2	-1.5	1.53 V	230	60.0	6.7
5	#14230.00	56.6 PK	88.2	-31.6	1.33 V	264	47.1	9.5
6	#14230.00	46.4 AV	68.2	-21.8	1.33 V	264	36.9	9.5

**Remarks:**

1. Emission Level(dBuV/m) = Raw Value(dBuV) + Correction Factor(dB/m)
2. Correction Factor(dB/m) = Antenna Factor(dB/m) + Cable Factor(dB) – Pre-Amplifier Factor(dB)
3. Margin value = Emission Level – Limit value
4. The other emission levels were very low against the limit.
5. " \* " : Fundamental frequency.
6. " # " : The radiated frequency is out of the restricted band.

RF Mode	TX 20MHz Preamble 802.11ax (RU242)	Channel	CH 233 : 7115 MHz
Frequency Range	1GHz ~ 40GHz	Detector Function	Peak (PK) Average (AV)

**Antenna Polarity & Test Distance : Horizontal at 3 m**

No	Frequency (MHz)	Emission Level (dBuV/m)	Limit (dBuV/m)	Margin (dB)	Antenna Height (m)	Table Angle (Degree)	Raw Value (dBuV)	Correction Factor (dB/m)
1	*7115.00	93.8 PK			2.06 H	101	48.6	45.2
2	*7115.00	83.2 AV			2.06 H	101	38.0	45.2
3	#7125.00	73.6 PK	88.2	-14.6	2.06 H	101	66.9	6.7
4	#7125.00	66.8 AV	68.2	-1.4	2.06 H	101	60.1	6.7
5	#14230.00	57.5 PK	88.2	-30.7	1.05 H	276	48.0	9.5
6	#14230.00	48.0 AV	68.2	-20.2	1.05 H	276	38.5	9.5

**Antenna Polarity & Test Distance : Vertical at 3 m**

No	Frequency (MHz)	Emission Level (dBuV/m)	Limit (dBuV/m)	Margin (dB)	Antenna Height (m)	Table Angle (Degree)	Raw Value (dBuV)	Correction Factor (dB/m)
1	*7115.00	92.6 PK			1.40 V	209	47.4	45.2
2	*7115.00	82.2 AV			1.40 V	209	37.0	45.2
3	#7125.00	73.9 PK	88.2	-14.3	1.40 V	209	67.2	6.7
4	#7125.00	67.7 AV	68.2	-0.5	1.40 V	209	61.0	6.7
5	#14230.00	58.0 PK	88.2	-30.2	1.42 V	268	48.5	9.5
6	#14230.00	48.6 AV	68.2	-19.6	1.42 V	268	39.1	9.5

**Remarks:**

1. Emission Level(dBuV/m) = Raw Value(dBuV) + Correction Factor(dB/m)
2. Correction Factor(dB/m) = Antenna Factor(dB/m) + Cable Factor(dB) – Pre-Amplifier Factor(dB)
3. Margin value = Emission Level – Limit value
4. The other emission levels were very low against the limit.
5. " \* " : Fundamental frequency.
6. " # " : The radiated frequency is out of the restricted band.

RF Mode	TX 40MHz Preamble 802.11ax (RU484)	Channel	CH 3 : 5965 MHz
Frequency Range	1GHz ~ 40GHz	Detector Function	Peak (PK) Average (AV)

Antenna Polarity & Test Distance : Horizontal at 3 m								
No	Frequency (MHz)	Emission Level (dBuV/m)	Limit (dBuV/m)	Margin (dB)	Antenna Height (m)	Table Angle (Degree)	Raw Value (dBuV)	Correction Factor (dB/m)
1	#5925.00	59.1 PK	88.2	-29.1	1.39 H	281	55.6	3.5
2	#5925.00	46.4 AV	68.2	-21.8	1.39 H	281	42.9	3.5
3	*5965.00	100.9 PK			1.39 H	281	59.2	41.7
4	*5965.00	90.2 AV			1.39 H	281	48.5	41.7
5	11930.00	55.1 PK	74.0	-18.9	1.09 H	66	47.4	7.7
6	11930.00	45.2 AV	54.0	-8.8	1.09 H	66	37.5	7.7

Antenna Polarity & Test Distance : Vertical at 3 m								
No	Frequency (MHz)	Emission Level (dBuV/m)	Limit (dBuV/m)	Margin (dB)	Antenna Height (m)	Table Angle (Degree)	Raw Value (dBuV)	Correction Factor (dB/m)
1	#5925.00	57.9 PK	88.2	-30.3	1.47 V	181	54.4	3.5
2	#5925.00	46.3 AV	68.2	-21.9	1.47 V	181	42.8	3.5
3	*5965.00	98.8 PK			1.47 V	181	57.1	41.7
4	*5965.00	88.1 AV			1.47 V	181	46.4	41.7
5	11930.00	54.7 PK	74.0	-19.3	1.42 V	268	47.0	7.7
6	11930.00	44.6 AV	54.0	-9.4	1.42 V	268	36.9	7.7

Remarks:

1. Emission Level(dBuV/m) = Raw Value(dBuV) + Correction Factor(dB/m)
2. Correction Factor(dB/m) = Antenna Factor(dB/m) + Cable Factor(dB) – Pre-Amplifier Factor(dB)
3. Margin value = Emission Level – Limit value
4. The other emission levels were very low against the limit.
5. " \* " : Fundamental frequency.
6. " # " : The radiated frequency is out of the restricted band.

RF Mode	TX 40MHz Preamble 802.11ax (RU484)	Channel	CH 227 : 7085 MHz
Frequency Range	1GHz ~ 40GHz	Detector Function	Peak (PK) Average (AV)

Antenna Polarity & Test Distance : Horizontal at 3 m								
No	Frequency (MHz)	Emission Level (dBuV/m)	Limit (dBuV/m)	Margin (dB)	Antenna Height (m)	Table Angle (Degree)	Raw Value (dBuV)	Correction Factor (dB/m)
1	*7085.00	104.4 PK			1.54 H	294	59.2	45.2
2	*7085.00	94.7 AV			1.54 H	294	49.5	45.2
3	#7125.00	61.7 PK	88.2	-26.5	1.54 H	294	55.0	6.7
4	#7125.00	49.9 AV	68.2	-18.3	1.54 H	294	43.2	6.7
5	#14170.00	56.7 PK	88.2	-31.5	1.03 H	92	47.1	9.6
6	#14170.00	46.4 AV	68.2	-21.8	1.03 H	92	36.8	9.6

Antenna Polarity & Test Distance : Vertical at 3 m								
No	Frequency (MHz)	Emission Level (dBuV/m)	Limit (dBuV/m)	Margin (dB)	Antenna Height (m)	Table Angle (Degree)	Raw Value (dBuV)	Correction Factor (dB/m)
1	*7085.00	106.9 PK			1.54 V	231	61.7	45.2
2	*7085.00	95.3 AV			1.54 V	231	50.1	45.2
3	#7125.00	63.4 PK	88.2	-24.8	1.54 V	231	56.7	6.7
4	#7125.00	50.2 AV	68.2	-18.0	1.54 V	231	43.5	6.7
5	#14170.00	56.8 PK	88.2	-31.4	1.44 V	279	47.2	9.6
6	#14170.00	46.5 AV	68.2	-21.7	1.44 V	279	36.9	9.6

Remarks:

1. Emission Level(dBuV/m) = Raw Value(dBuV) + Correction Factor(dB/m)
2. Correction Factor(dB/m) = Antenna Factor(dB/m) + Cable Factor(dB) – Pre-Amplifier Factor(dB)
3. Margin value = Emission Level – Limit value
4. The other emission levels were very low against the limit.
5. " \* " : Fundamental frequency.
6. " # " : The radiated frequency is out of the restricted band.



RF Mode	TX 80MHz Preamble 802.11ax (RU996)	Channel	CH 7 : 5985 MHz
Frequency Range	1GHz ~ 40GHz	Detector Function	Peak (PK) Average (AV)

Antenna Polarity & Test Distance : Horizontal at 3 m								
No	Frequency (MHz)	Emission Level (dBuV/m)	Limit (dBuV/m)	Margin (dB)	Antenna Height (m)	Table Angle (Degree)	Raw Value (dBuV)	Correction Factor (dB/m)
1	#5925.00	57.7 PK	88.2	-30.5	1.41 H	283	54.2	3.5
2	#5925.00	46.7 AV	68.2	-21.5	1.41 H	283	43.2	3.5
3	*5985.00	98.1 PK			1.41 H	283	56.3	41.8
4	*5985.00	86.9 AV			1.41 H	283	45.1	41.8
5	11970.00	55.1 PK	74.0	-18.9	1.04 H	274	47.3	7.8
6	11970.00	44.9 AV	54.0	-9.1	1.04 H	274	37.1	7.8

Antenna Polarity & Test Distance : Vertical at 3 m								
No	Frequency (MHz)	Emission Level (dBuV/m)	Limit (dBuV/m)	Margin (dB)	Antenna Height (m)	Table Angle (Degree)	Raw Value (dBuV)	Correction Factor (dB/m)
1	#5925.00	58.4 PK	88.2	-29.8	1.59 V	182	54.9	3.5
2	#5925.00	46.2 AV	68.2	-22.0	1.59 V	182	42.7	3.5
3	*5985.00	95.4 PK			1.59 V	182	53.6	41.8
4	*5985.00	85.6 AV			1.59 V	182	43.8	41.8
5	11970.00	54.7 PK	74.0	-19.3	1.33 V	268	46.9	7.8
6	11970.00	44.6 AV	54.0	-9.4	1.33 V	268	36.8	7.8

Remarks:

1. Emission Level(dBuV/m) = Raw Value(dBuV) + Correction Factor(dB/m)
2. Correction Factor(dB/m) = Antenna Factor(dB/m) + Cable Factor(dB) – Pre-Amplifier Factor(dB)
3. Margin value = Emission Level – Limit value
4. The other emission levels were very low against the limit.
5. " \* " : Fundamental frequency.
6. " # " : The radiated frequency is out of the restricted band.

RF Mode	TX 80MHz Preamble 802.11ax (RU996)	Channel	CH 215 : 7025 MHz
Frequency Range	1GHz ~ 40GHz	Detector Function	Peak (PK) Average (AV)

Antenna Polarity & Test Distance : Horizontal at 3 m								
No	Frequency (MHz)	Emission Level (dBuV/m)	Limit (dBuV/m)	Margin (dB)	Antenna Height (m)	Table Angle (Degree)	Raw Value (dBuV)	Correction Factor (dB/m)
1	*7025.00	104.2 PK			1.79 H	250	59.2	45.0
2	*7025.00	93.5 AV			1.79 H	250	48.5	45.0
3	#7125.00	66.7 PK	88.2	-21.5	1.79 H	250	60.0	6.7
4	#7125.00	55.7 AV	68.2	-12.5	1.79 H	250	49.0	6.7
5	#14050.00	56.5 PK	88.2	-31.7	1.10 H	69	47.1	9.4
6	#14050.00	46.2 AV	68.2	-22.0	1.10 H	69	36.8	9.4

Antenna Polarity & Test Distance : Vertical at 3 m								
No	Frequency (MHz)	Emission Level (dBuV/m)	Limit (dBuV/m)	Margin (dB)	Antenna Height (m)	Table Angle (Degree)	Raw Value (dBuV)	Correction Factor (dB/m)
1	*7025.00	105.0 PK			1.69 V	226	60.0	45.0
2	*7025.00	94.2 AV			1.69 V	226	49.2	45.0
3	#7125.00	67.6 PK	88.2	-20.6	1.69 V	226	60.9	6.7
4	#7125.00	53.9 AV	68.2	-14.3	1.69 V	226	47.2	6.7
5	#14050.00	57.9 PK	88.2	-30.3	1.44 V	273	48.5	9.4
6	#14050.00	46.6 AV	68.2	-21.6	1.44 V	273	37.2	9.4

Remarks:

1. Emission Level(dBuV/m) = Raw Value(dBuV) + Correction Factor(dB/m)
2. Correction Factor(dB/m) = Antenna Factor(dB/m) + Cable Factor(dB) – Pre-Amplifier Factor(dB)
3. Margin value = Emission Level – Limit value
4. The other emission levels were very low against the limit.
5. " \* ": Fundamental frequency.
6. " # ": The radiated frequency is out of the restricted band.

RF Mode	TX 160MHz Preamble 802.11ax (RU996*2)	Channel	CH 15 : 6025 MHz
Frequency Range	1GHz ~ 40GHz	Detector Function	Peak (PK) Average (AV)

**Antenna Polarity & Test Distance : Horizontal at 3 m**

No	Frequency (MHz)	Emission Level (dBuV/m)	Limit (dBuV/m)	Margin (dB)	Antenna Height (m)	Table Angle (Degree)	Raw Value (dBuV)	Correction Factor (dB/m)
1	#5925.00	62.6 PK	88.2	-25.6	1.42 H	280	59.1	3.5
2	#5925.00	48.4 AV	68.2	-19.8	1.42 H	280	44.9	3.5
3	*6025.00	96.0 PK			1.42 H	280	54.1	41.9
4	*6025.00	86.4 AV			1.42 H	280	44.5	41.9
5	12050.00	54.6 PK	74.0	-19.4	1.28 H	262	46.9	7.7
6	12050.00	45.0 AV	54.0	-9.0	1.28 H	262	37.3	7.7

**Antenna Polarity & Test Distance : Vertical at 3 m**

No	Frequency (MHz)	Emission Level (dBuV/m)	Limit (dBuV/m)	Margin (dB)	Antenna Height (m)	Table Angle (Degree)	Raw Value (dBuV)	Correction Factor (dB/m)
1	#5925.00	58.0 PK	88.2	-30.2	1.42 V	187	54.5	3.5
2	#5925.00	47.2 AV	68.2	-21.0	1.42 V	187	43.7	3.5
3	*6025.00	94.9 PK			1.42 V	187	53.0	41.9
4	*6025.00	84.0 AV			1.42 V	187	42.1	41.9
5	12050.00	54.5 PK	74.0	-19.5	1.01 V	80	46.8	7.7
6	12050.00	44.9 AV	54.0	-9.1	1.01 V	80	37.2	7.7

**Remarks:**

1. Emission Level(dBuV/m) = Raw Value(dBuV) + Correction Factor(dB/m)
2. Correction Factor(dB/m) = Antenna Factor(dB/m) + Cable Factor(dB) – Pre-Amplifier Factor(dB)
3. Margin value = Emission Level – Limit value
4. The other emission levels were very low against the limit.
5. " \* " : Fundamental frequency.
6. " # " : The radiated frequency is out of the restricted band.

RF Mode	TX 160MHz Preamble 802.11ax (RU996*2)	Channel	CH 207 : 6985 MHz
Frequency Range	1GHz ~ 40GHz	Detector Function	Peak (PK) Average (AV)

Antenna Polarity & Test Distance : Horizontal at 3 m								
No	Frequency (MHz)	Emission Level (dBuV/m)	Limit (dBuV/m)	Margin (dB)	Antenna Height (m)	Table Angle (Degree)	Raw Value (dBuV)	Correction Factor (dB/m)
1	*6985.00	105.8 PK			1.80 H	249	60.8	45.0
2	*6985.00	95.1 AV			1.80 H	249	50.1	45.0
3	#7125.00	81.6 PK	88.2	-6.6	1.80 H	249	74.9	6.7
4	#7125.00	65.1 AV	68.2	-3.1	1.80 H	249	58.4	6.7
5	#13970.00	56.6 PK	88.2	-31.6	1.08 H	63	47.3	9.3
6	#13970.00	46.6 AV	68.2	-21.6	1.08 H	63	37.3	9.3

Antenna Polarity & Test Distance : Vertical at 3 m								
No	Frequency (MHz)	Emission Level (dBuV/m)	Limit (dBuV/m)	Margin (dB)	Antenna Height (m)	Table Angle (Degree)	Raw Value (dBuV)	Correction Factor (dB/m)
1	*6985.00	107.4 PK			1.02 V	195	62.4	45.0
2	*6985.00	96.5 AV			1.02 V	195	51.5	45.0
3	#7125.00	83.4 PK	88.2	-4.8	1.02 V	195	76.7	6.7
4	#7125.00	65.5 AV	68.2	-2.7	1.02 V	195	58.8	6.7
5	#13970.00	56.2 PK	88.2	-32.0	1.33 V	273	46.9	9.3
6	#13970.00	46.2 AV	68.2	-22.0	1.33 V	273	36.9	9.3

Remarks:

1. Emission Level(dBuV/m) = Raw Value(dBuV) + Correction Factor(dB/m)
2. Correction Factor(dB/m) = Antenna Factor(dB/m) + Cable Factor(dB) – Pre-Amplifier Factor(dB)
3. Margin value = Emission Level – Limit value
4. The other emission levels were very low against the limit.
5. " \* ": Fundamental frequency.
6. " # ": The radiated frequency is out of the restricted band.

**Below 1GHz Data:**

RF Mode	TX 802.11ax (HE160)	Channel	CH 207 : 6985 MHz
Frequency Range	30MHz ~ 1GHz	Detector Function	Quasi-Peak (QP)

Antenna Polarity & Test Distance : Horizontal at 3 m								
No	Frequency (MHz)	Emission Level (dBuV/m)	Limit (dBuV/m)	Margin (dB)	Antenna Height (m)	Table Angle (Degree)	Raw Value (dBuV)	Correction Factor (dB/m)
1	31.94	28.0 QP	40.0	-12.0	2.00 H	300	47.6	-19.6
2	51.34	23.9 QP	40.0	-16.1	1.00 H	159	42.2	-18.3
3	87.23	27.6 QP	40.0	-12.4	1.50 H	159	51.6	-24.0
4	127.97	23.1 QP	43.5	-20.4	1.00 H	15	42.9	-19.8
5	160.95	38.1 QP	43.5	-5.4	1.50 H	175	56.6	-18.5
6	206.54	25.7 QP	43.5	-17.8	1.00 H	80	47.3	-21.6

**Remarks:**

1. Emission Level(dBuV/m) = Raw Value(dBuV) + Correction Factor(dB/m)
2. Correction Factor(dB/m) = Antenna Factor(dB/m) + Cable Factor(dB) – Pre-Amplifier Factor(dB)
3. Margin value = Emission Level – Limit value
4. The other emission levels were very low against the limit of frequency range 30MHz~1000MHz.
5. The emission levels were very low against the limit of frequency range 9kHz~30MHz: the amplitude of spurious emissions attenuated more than 20 dB below the permissible value to be report.

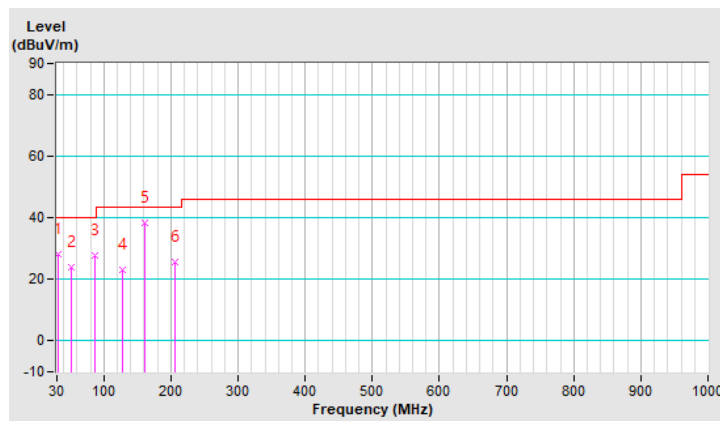

RF Mode	TX 802.11ax (HE160)	Channel	CH 207 : 6985 MHz
Frequency Range	30MHz ~ 1GHz	Detector Function	Quasi-Peak (QP)

**Antenna Polarity & Test Distance : Vertical at 3 m**

No	Frequency (MHz)	Emission Level (dBuV/m)	Limit (dBuV/m)	Margin (dB)	Antenna Height (m)	Table Angle (Degree)	Raw Value (dBuV)	Correction Factor (dB/m)
1	31.94	28.7 QP	40.0	-11.3	1.00 V	95	48.3	-19.6
2	72.68	31.8 QP	40.0	-8.2	1.00 V	110	53.1	-21.3
3	107.60	22.3 QP	43.5	-21.2	1.00 V	353	44.0	-21.7
4	120.21	29.5 QP	43.5	-14.0	1.00 V	345	50.0	-20.5
5	162.89	20.5 QP	43.5	-23.0	1.00 V	335	38.9	-18.4
6	617.82	30.7 QP	46.0	-15.3	1.00 V	5	41.1	-10.4

**Remarks:**

1. Emission Level(dBuV/m) = Raw Value(dBuV) + Correction Factor(dB/m)
2. Correction Factor(dB/m) = Antenna Factor(dB/m) + Cable Factor(dB) – Pre-Amplifier Factor(dB)
3. Margin value = Emission Level – Limit value
4. The other emission levels were very low against the limit of frequency range 30MHz~1000MHz.
5. The emission levels were very low against the limit of frequency range 9kHz~30MHz: the amplitude of spurious emissions attenuated more than 20 dB below the permissible value to be report.

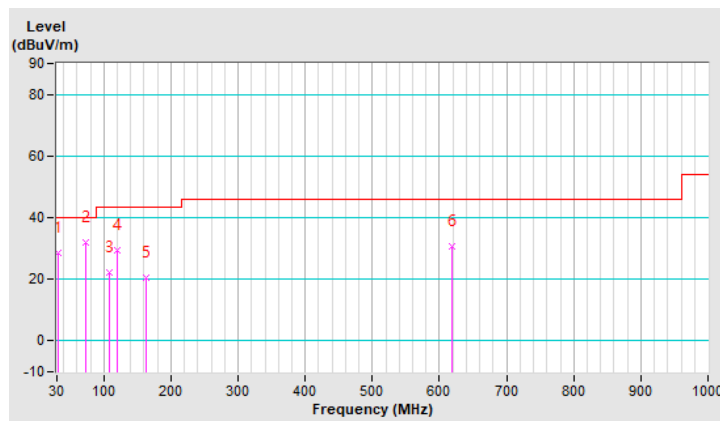

## 4.2 In-Band Emission (Mask) Measurement

### 4.2.1 Limits of In-Band Emission (Mask) Measurement

Test Item	Frequencies (MHz)	(X) dBc <sup>*1</sup>
Emission Mask	At 1 MHz outside of channel edge	20
	At one channel bandwidth from the channel center <sup>*2</sup>	28
	At one- and one-half times the channel bandwidth away from channel center <sup>*3</sup>	40
	More than one- and one-half times the channel bandwidth	40

\*1 :The power spectral density must be suppressed by “x” dB

\*2 : At frequencies between one megahertz outside an unlicensed device’s channel edge and one channel bandwidth from the center of the channel, the limits must be linearly interpolated between 20 dB and 28 dB suppression,

\*3 : At frequencies between one and one- and one-half times an unlicensed device’s channel bandwidth, the limits must be linearly interpolated between 28 dB and 40 dB suppression.

### 4.2.2 Test Setup



### 4.2.3 Test Instruments

Refer to section 4.1.2 to get information of above instrument.

#### 4.2.4 Test Procedure

- a. Connect output of the antenna port to a spectrum analyzer and adjust appropriate attenuation.
- b. Measure the 26 dB EBW using the test procedure 12.4.1 of ANSI C63.10-2013. (Determine the channel edge.)
- c. Measure the power spectral density ( for emissions mask reference) using the following procedure:
  - a) Set the span to encompass the entire 26 dB EBW of the signal.
  - b) Set RBW = same RBW used for 26 dB EBW measurement.
  - c) Set VBW  $\geq 3 \times$  RBW
  - d) Number of points in sweep  $\geq [2 \times$  span / RBW].
  - e) Sweep time = auto.
  - f) Detector = RMS (i.e., power averaging)
  - g) Trace average at least 100 traces in power averaging (rms) mode.
  - h) Use the peak search function on the instrument to find the peak of the spectrum.
- d. Using the measuring equipment limit line function, develop the emissions mask based on the following requirements. The emissions power spectral density must be reduced below the peak power spectral density (in dB) as follows:
  - a) Suppressed by 20 dB at 1 MHz outside of the channel edge. (The channel edge is defined as the 26-dB point on either side of the carrier center frequency.)
  - b) Suppressed by 28 dB at one channel bandwidth from the channel center.
  - c) Suppressed by 40 dB at one- and one-half times the channel bandwidth from the channel center.
- e. Adjust the span to encompass the entire mask as necessary and clear trace.
- f. Trace average at least 100 traces in power averaging (rms) mode.
- g. Adjust the reference level as necessary so that the crest of the channel touches the top of the emission mask

#### 4.2.5 EUT Operating Condition

The software provided by client to enable the EUT under transmission condition continuously at lowest, middle and highest channel frequencies individually.



4.2.6 Test Results

802.11a

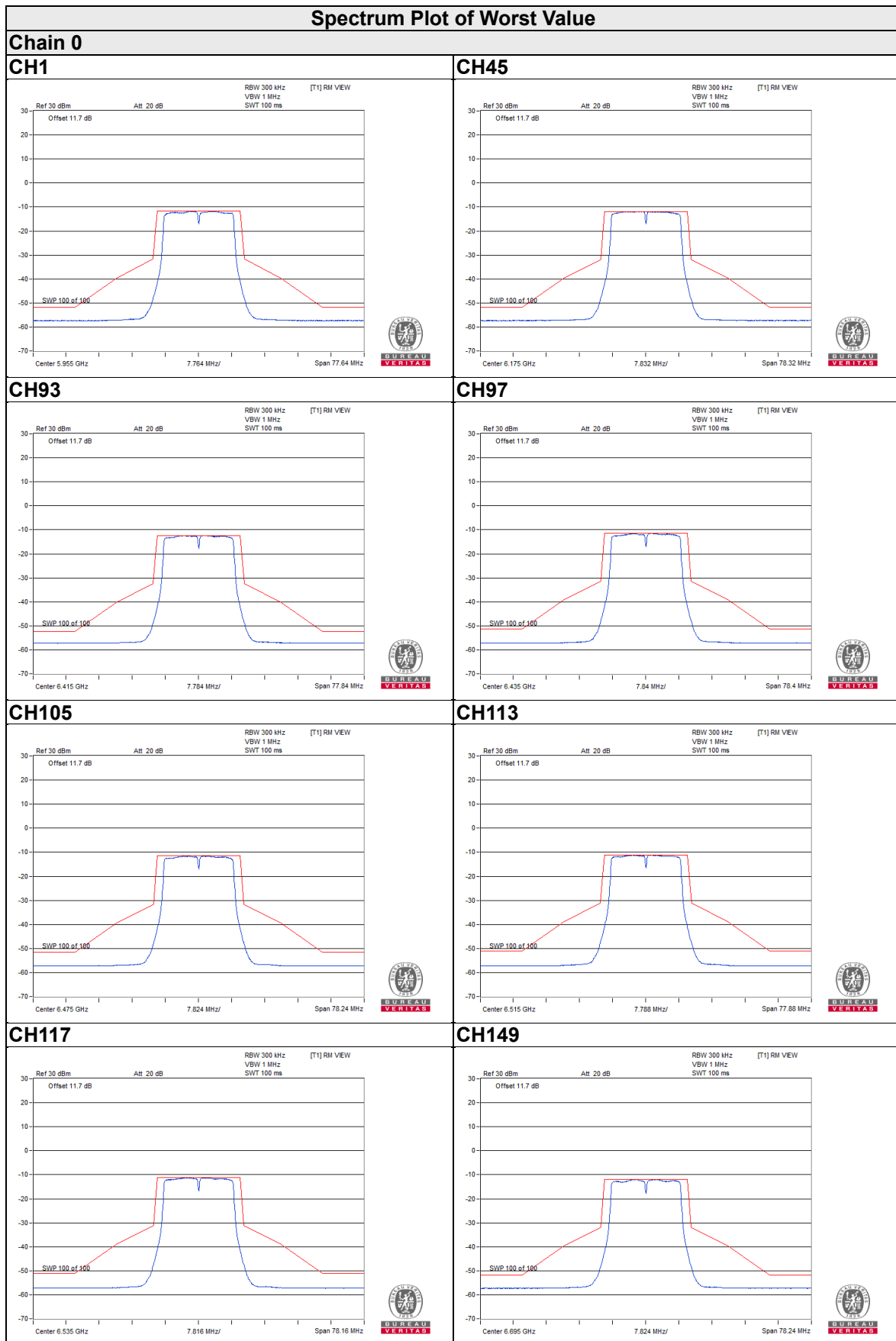

### Spectrum Plot of Worst Value

#### Chain 0

#### CH181

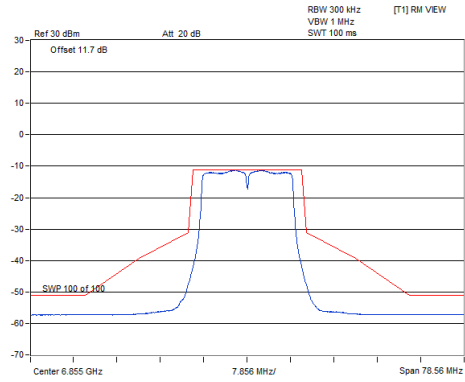

#### CH185

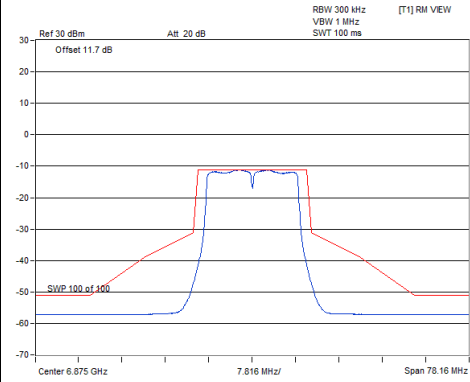

#### CH209

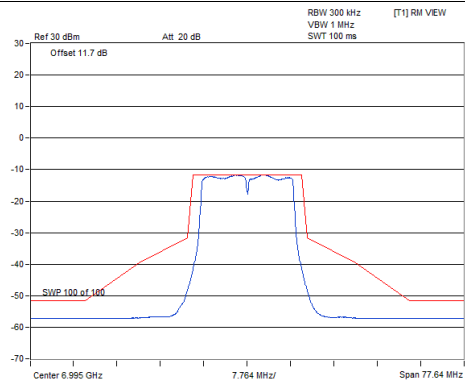

#### CH233

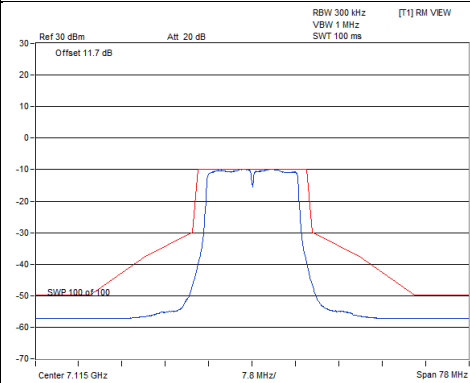

### Spectrum Plot of Worst Value

#### Chain 1

#### CH1

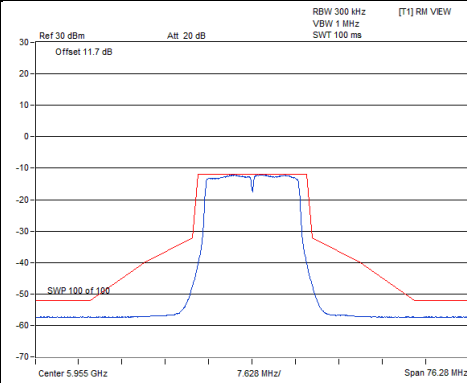

#### CH45

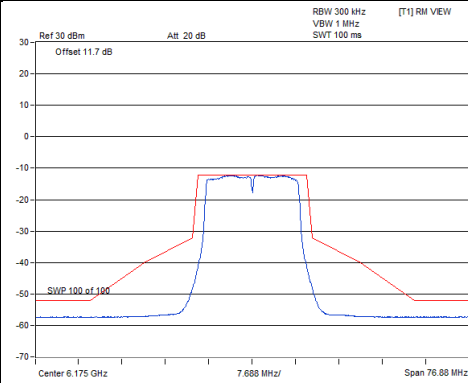

#### CH93

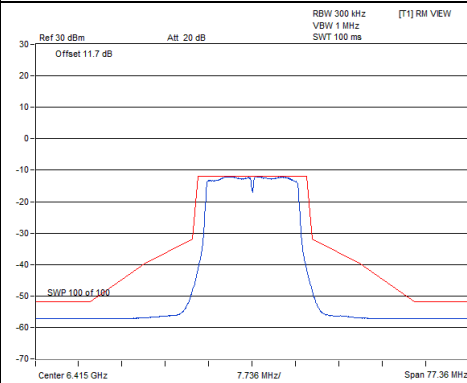

#### CH97

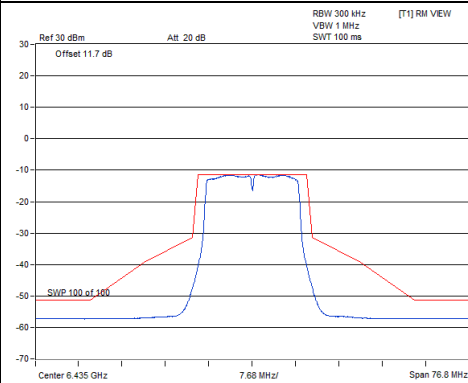

#### CH105

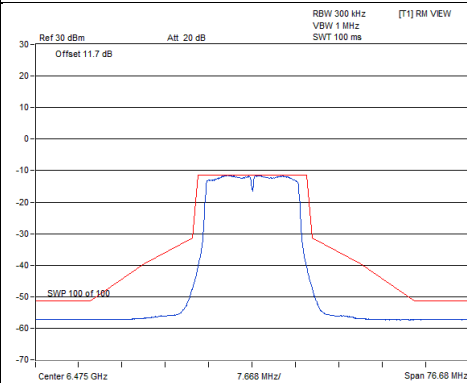

#### CH113

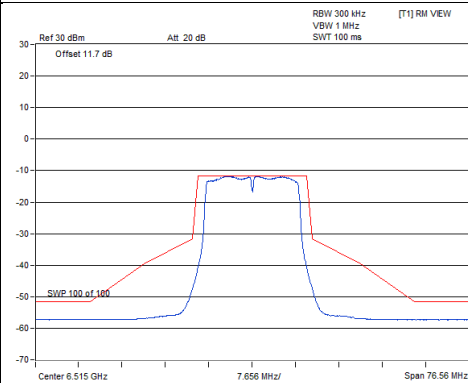

#### CH117

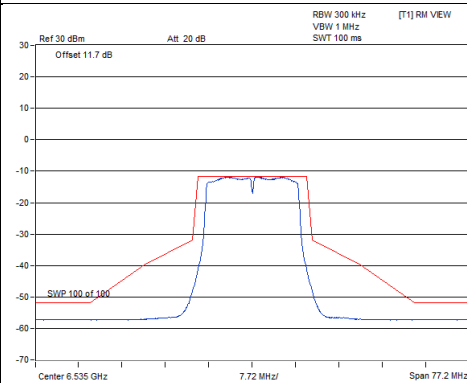

#### CH149

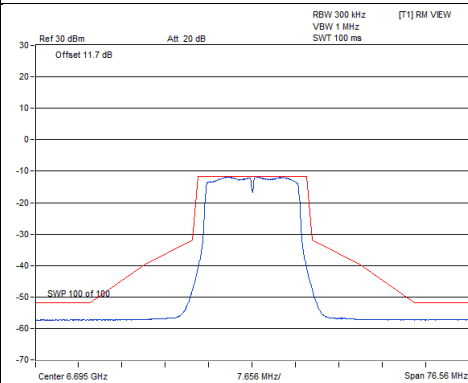

### Spectrum Plot of Worst Value

#### Chain 1

#### CH181

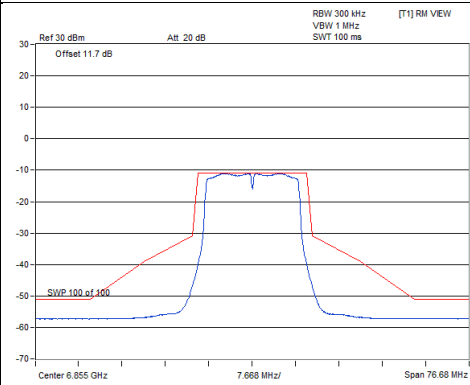

#### CH185

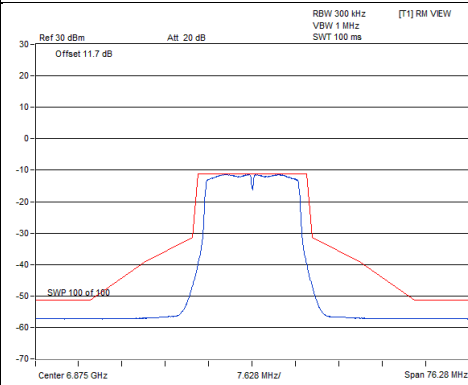

#### CH209

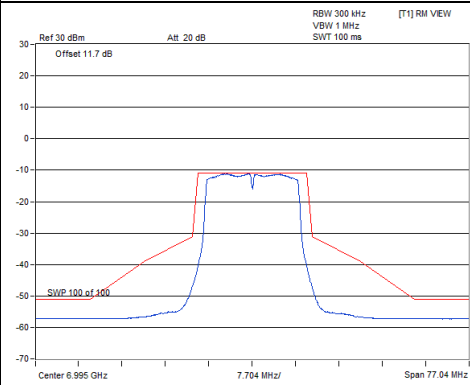

#### CH233

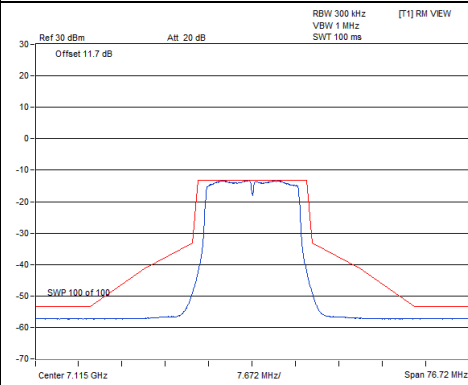

802.11ax (HE20)

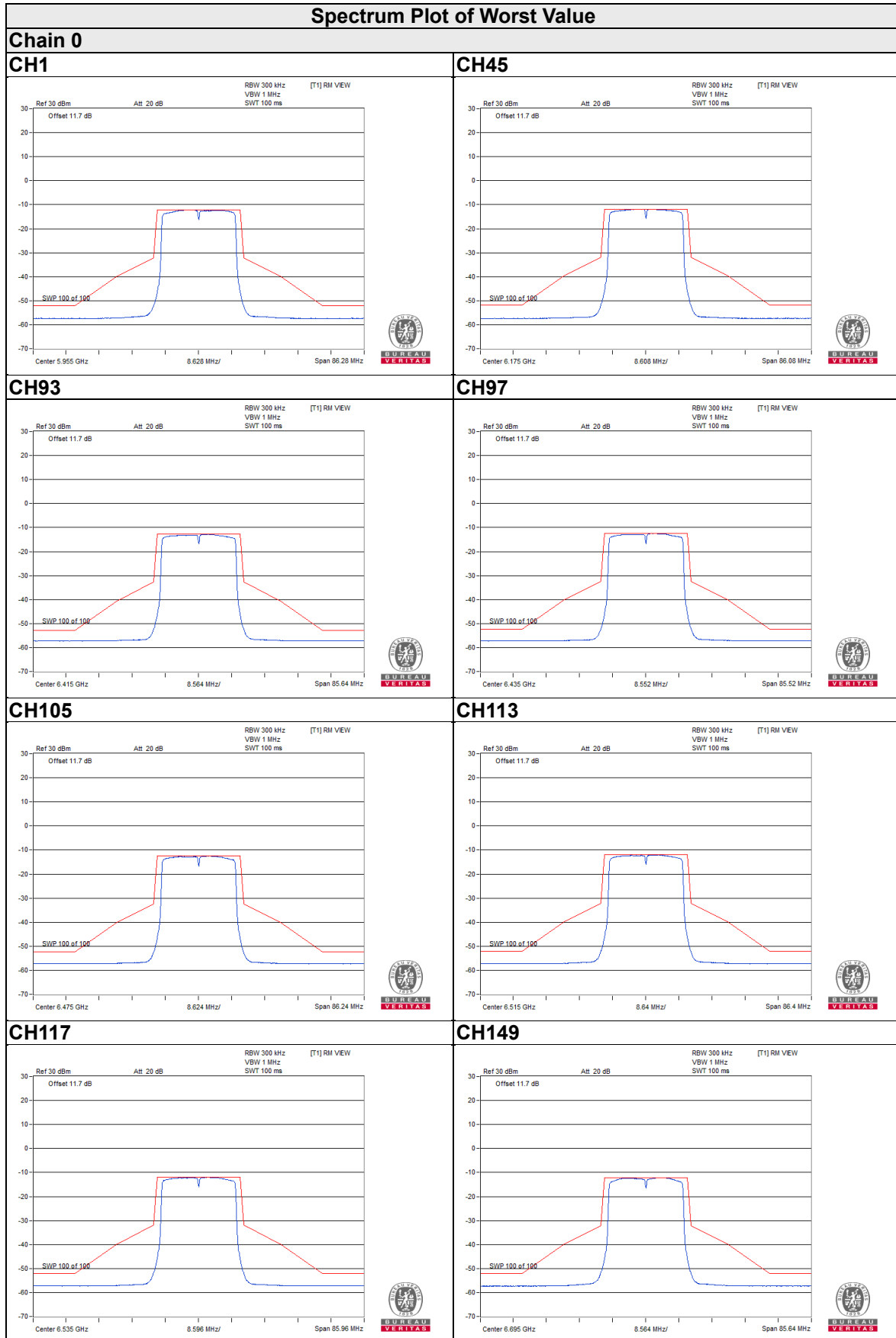

### Spectrum Plot of Worst Value

#### Chain 0

#### CH181

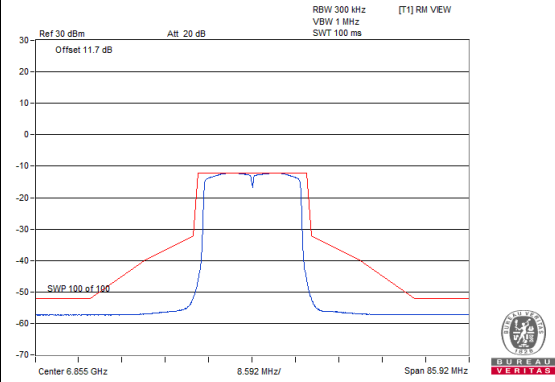

#### CH185

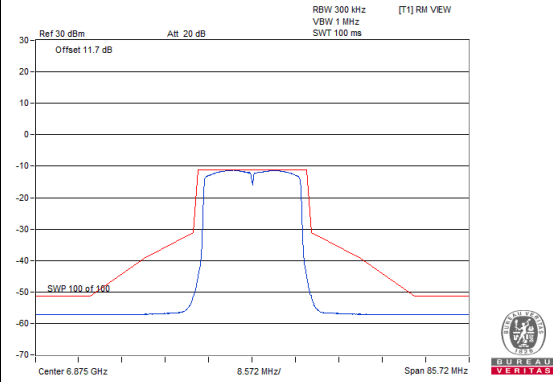

#### CH209

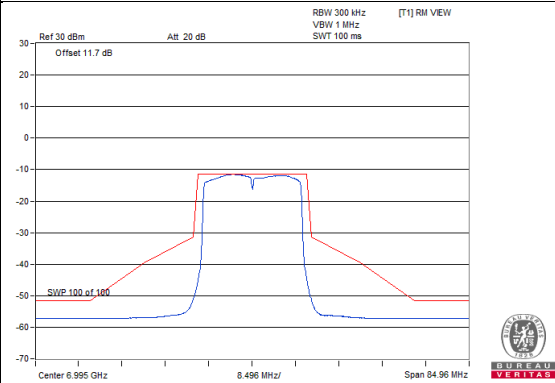

#### CH233

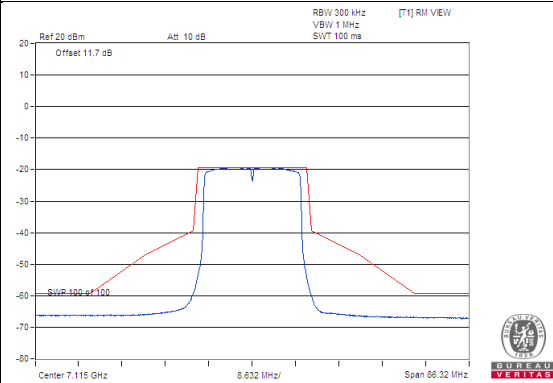

### Spectrum Plot of Worst Value

#### Chain 1

#### CH1

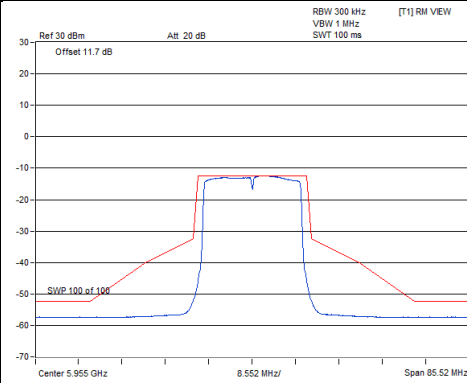

#### CH45

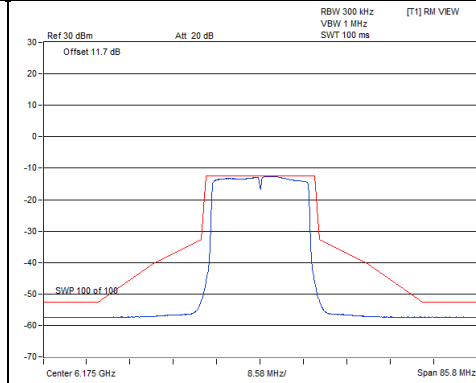

#### CH93

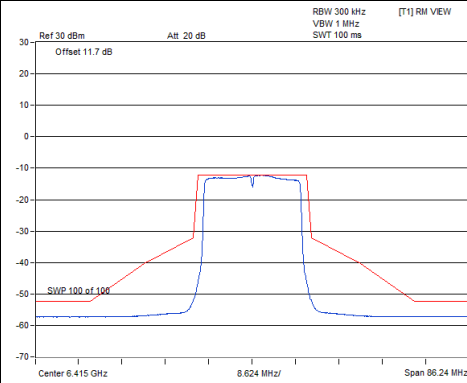

#### CH97

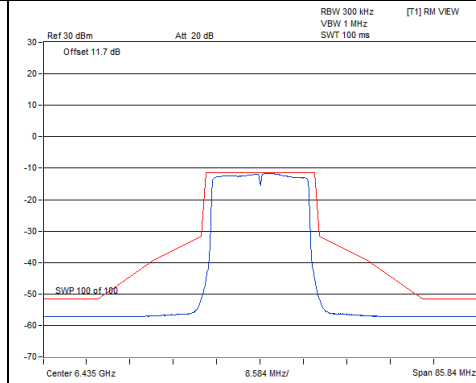

#### CH105

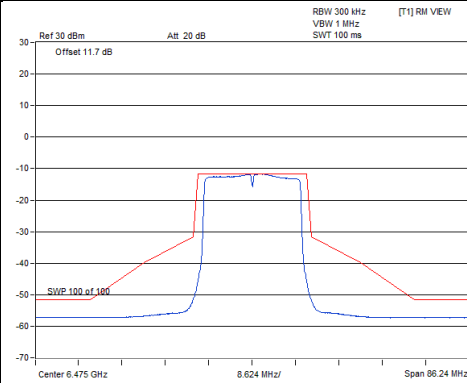

#### CH113

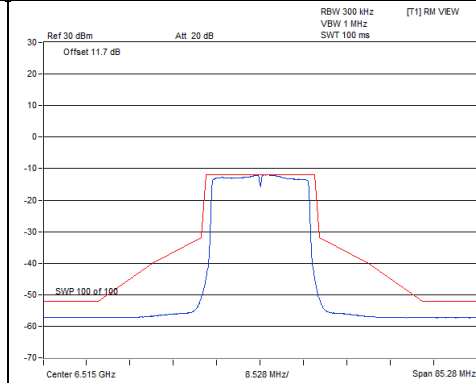

#### CH117

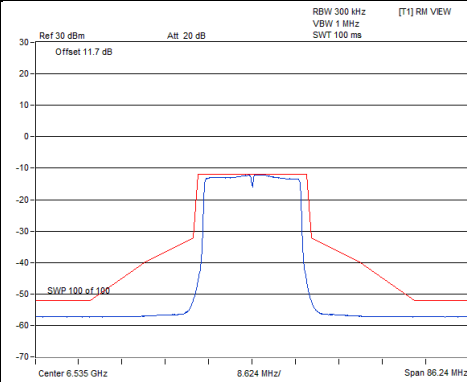

#### CH149

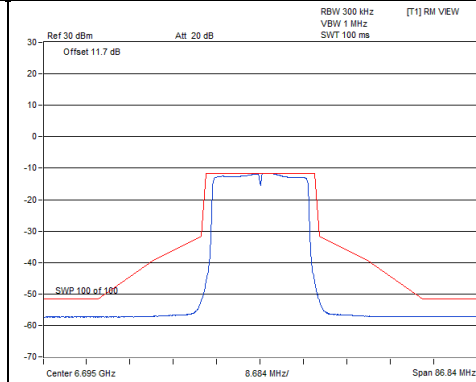

### Spectrum Plot of Worst Value

#### Chain 1

#### CH181

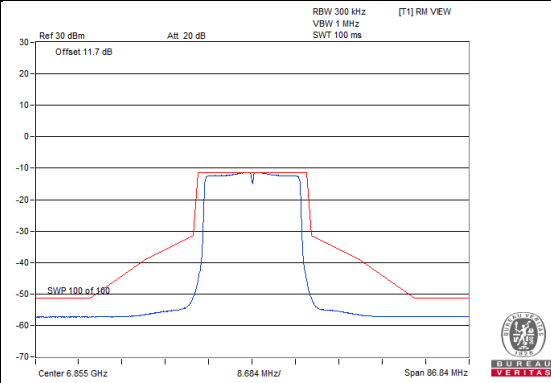

#### CH185

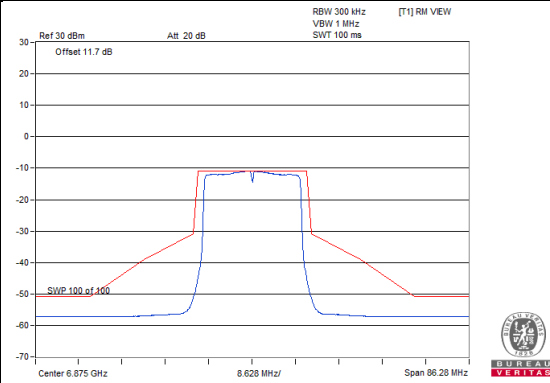

#### CH209

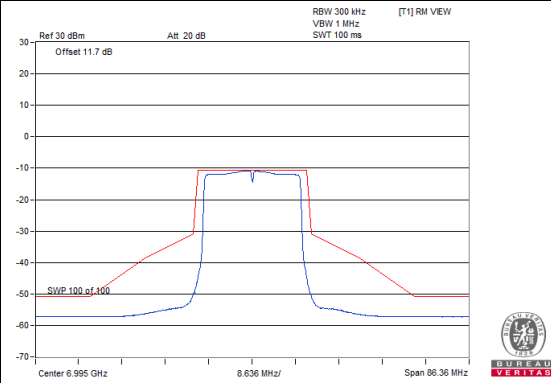

#### CH233

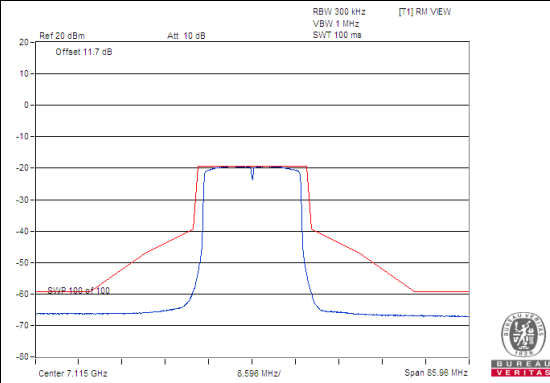



802.11ax (HE40)

Spectrum Plot of Worst Value

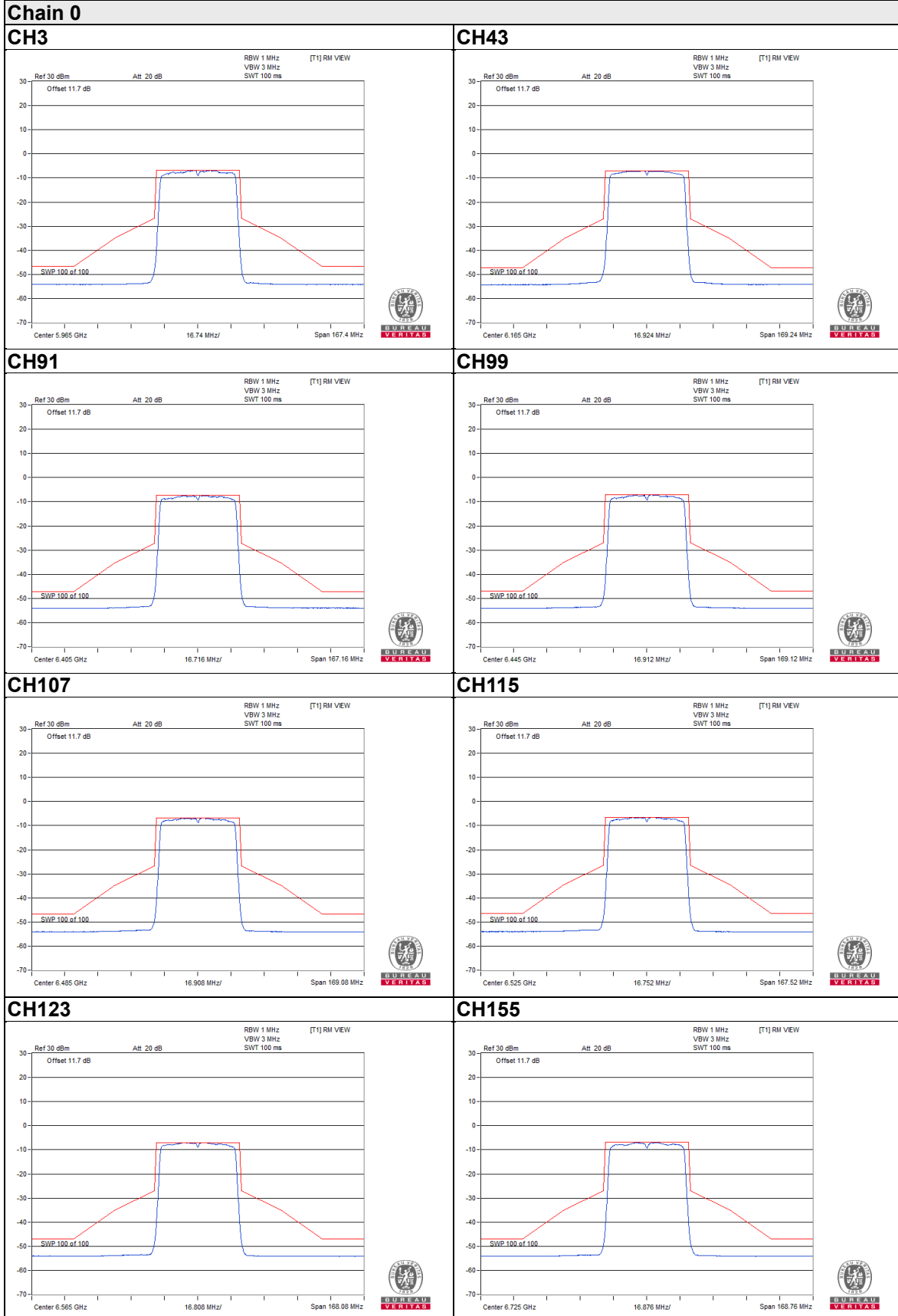

### Spectrum Plot of Worst Value

#### Chain 0

#### CH179

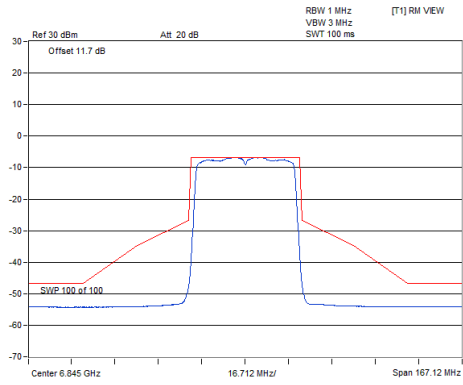

#### CH187

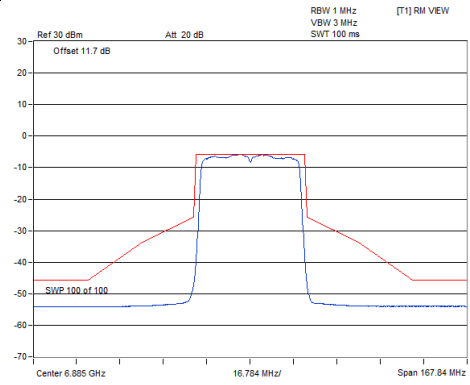

#### CH211

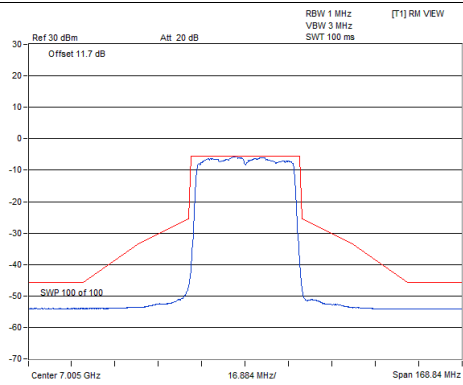

#### CH227

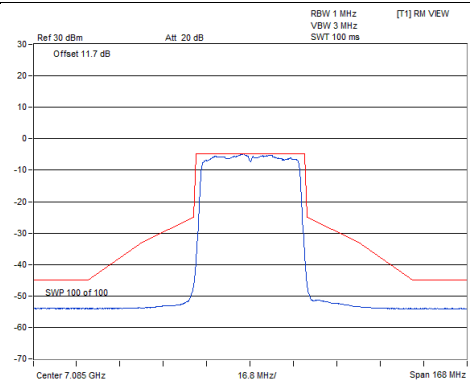

### Spectrum Plot of Worst Value

#### Chain 1

#### CH3

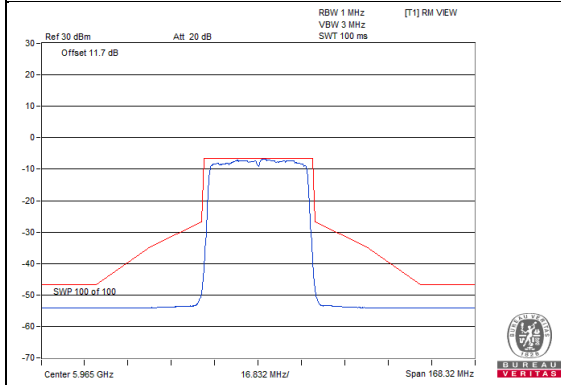

#### CH43

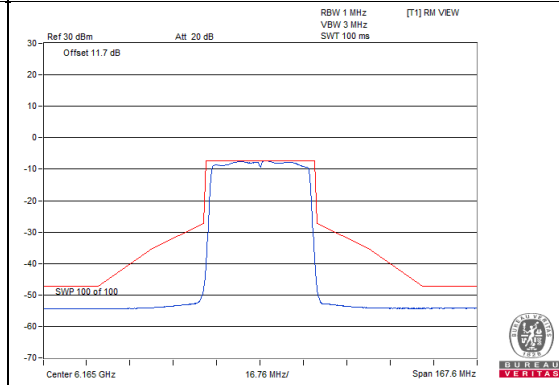

#### CH91

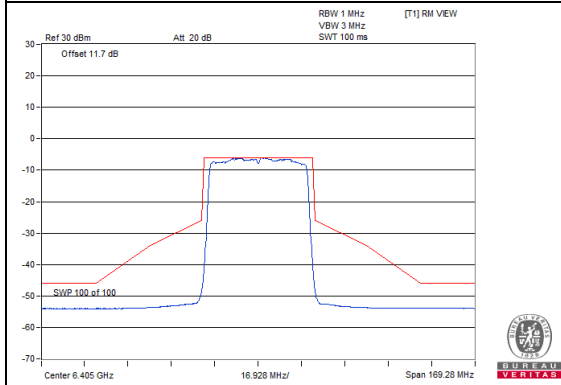

#### CH99

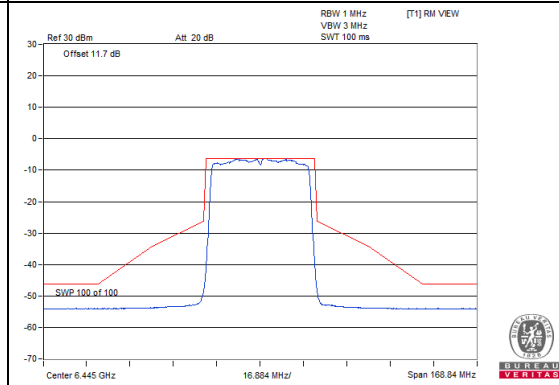

#### CH107

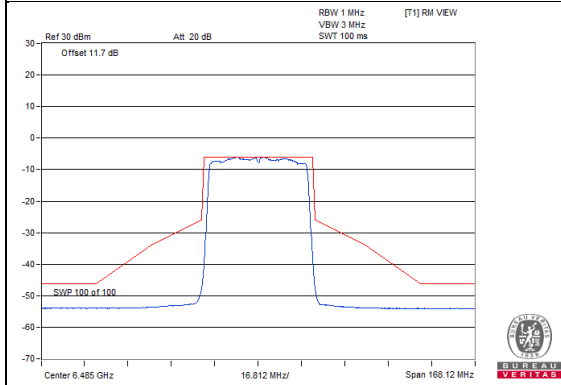

#### CH115

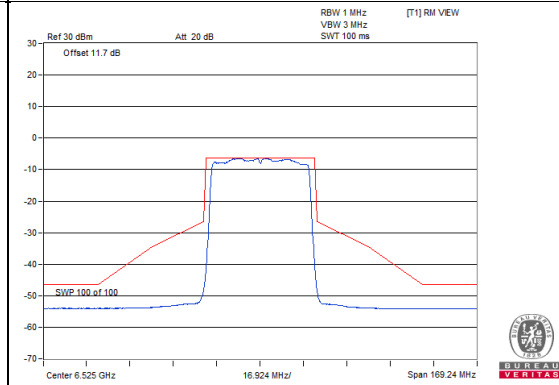

#### CH123

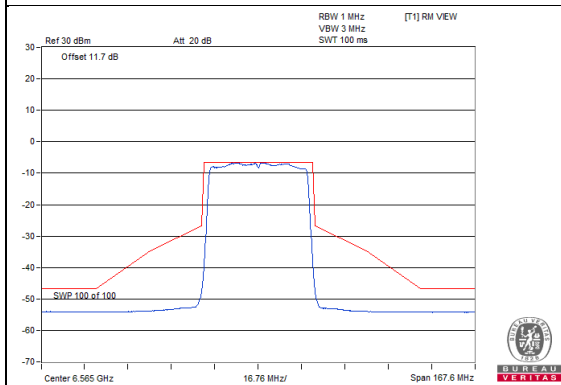

#### CH155

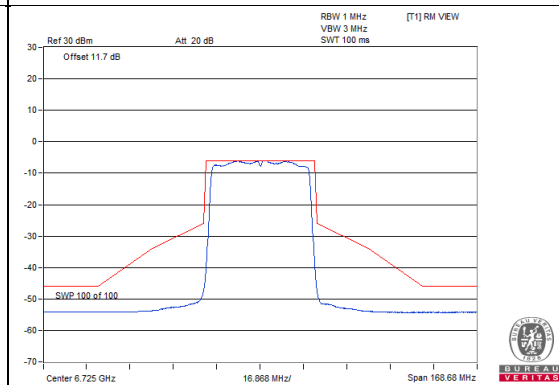

### Spectrum Plot of Worst Value

#### Chain 1

#### CH179

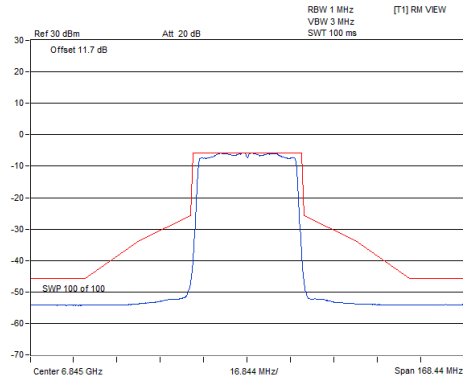

#### CH187

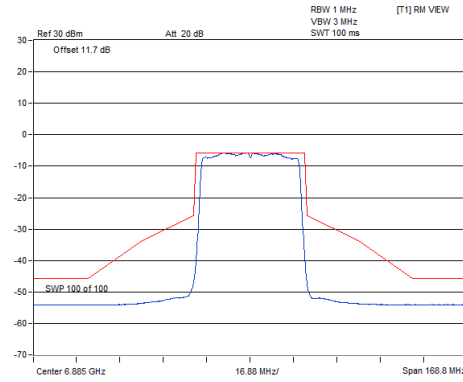

#### CH211

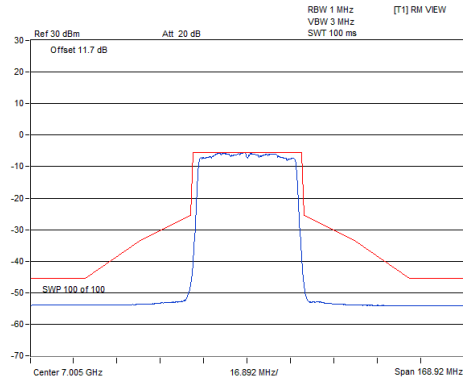

#### CH227

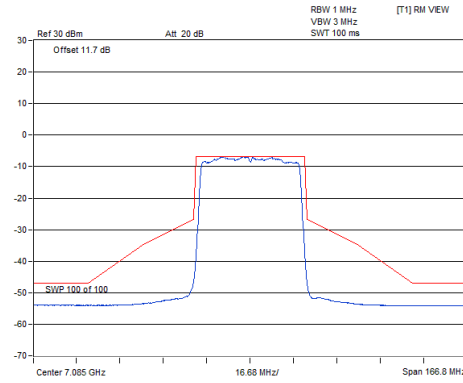

802.11ax (HE80)

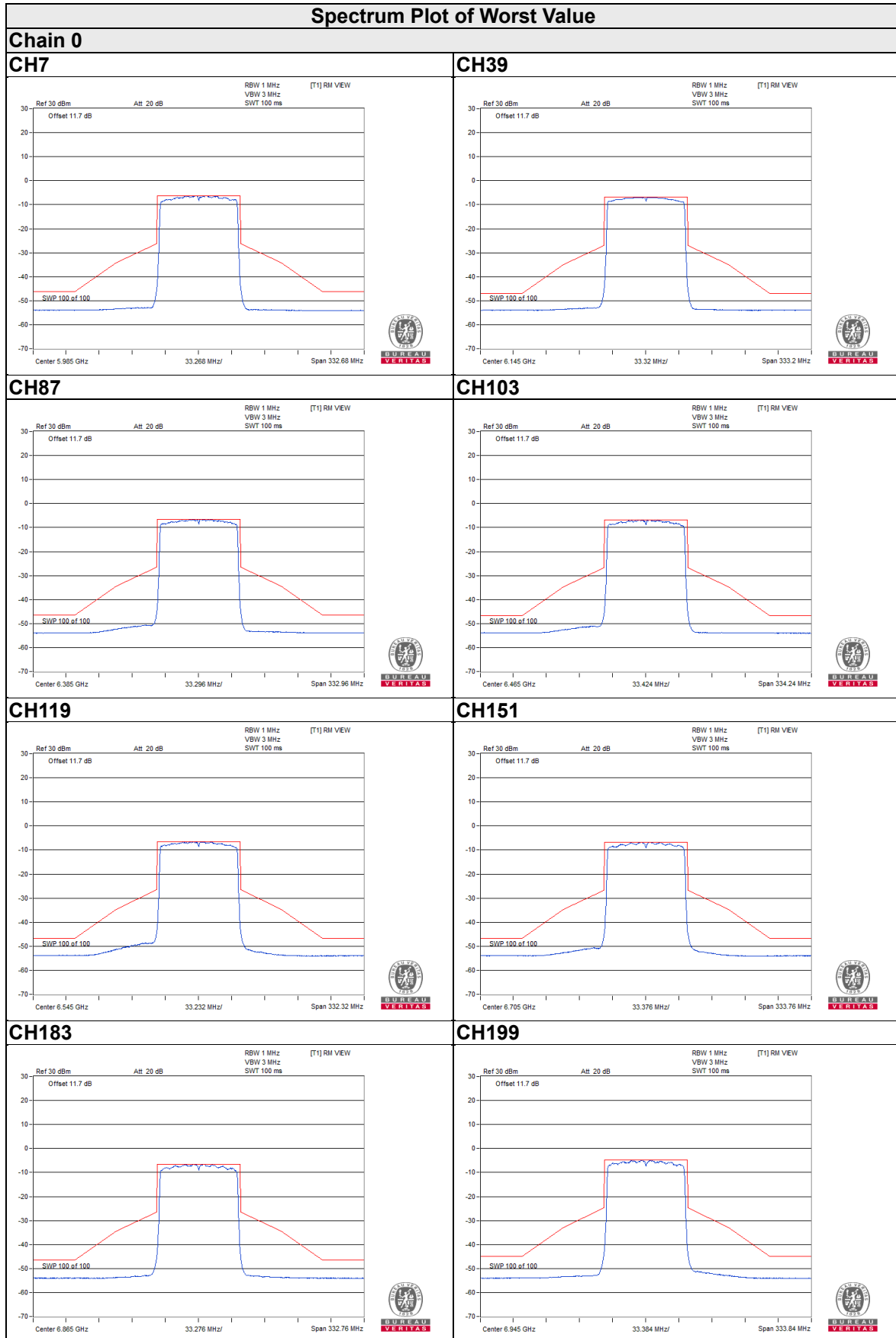

### Spectrum Plot of Worst Value

**Chain 0**

**CH215**

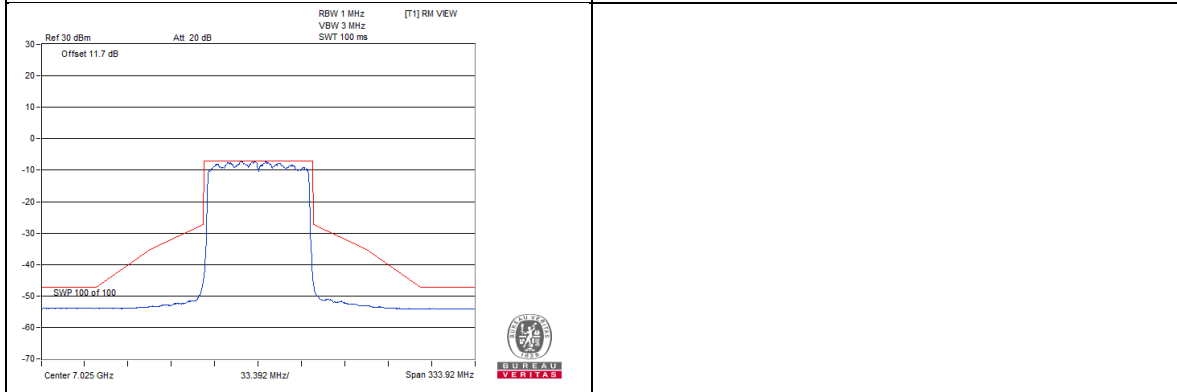

### Spectrum Plot of Worst Value

#### Chain 1

#### CH7

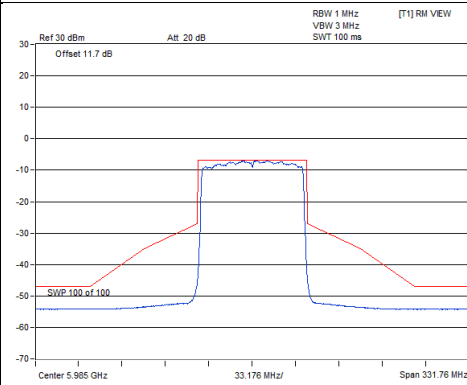

#### CH39

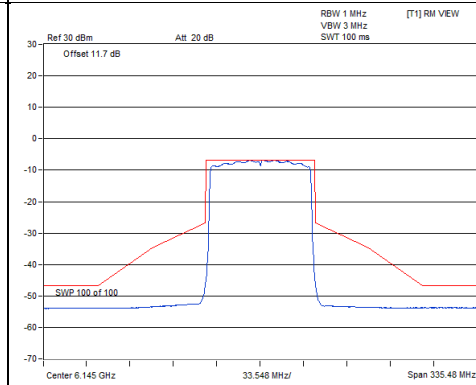

#### CH87

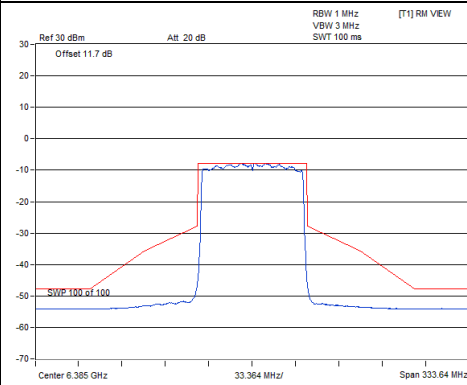

#### CH103

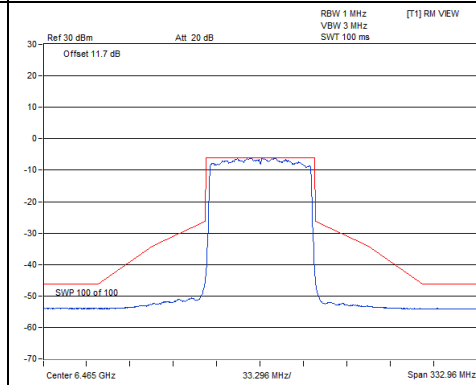

#### CH119

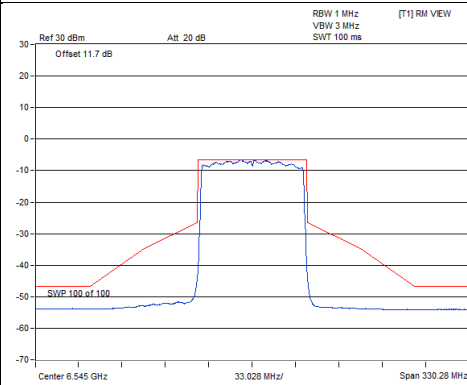

#### CH151

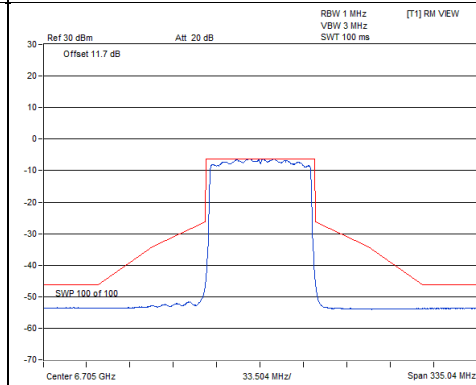

#### CH183

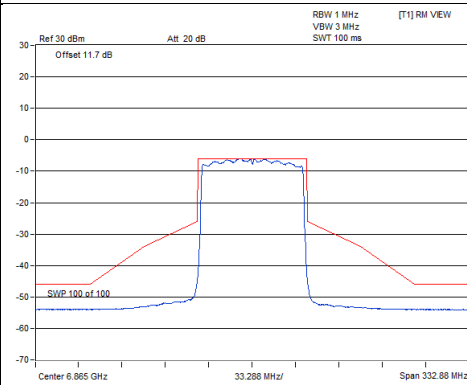

#### CH199

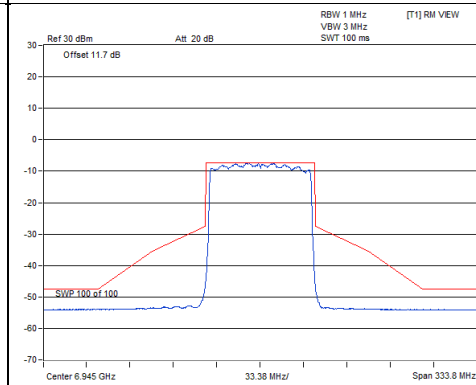

### Spectrum Plot of Worst Value

Chain 1

CH215

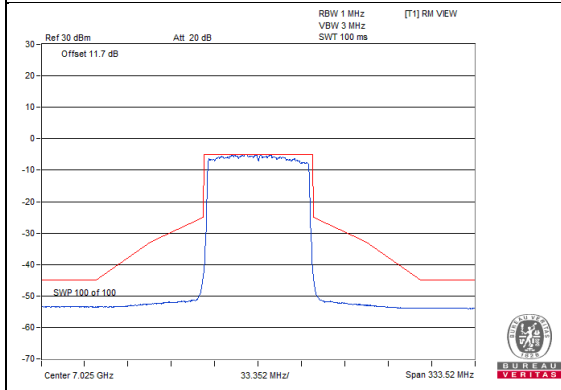



802.11ax (HE160)

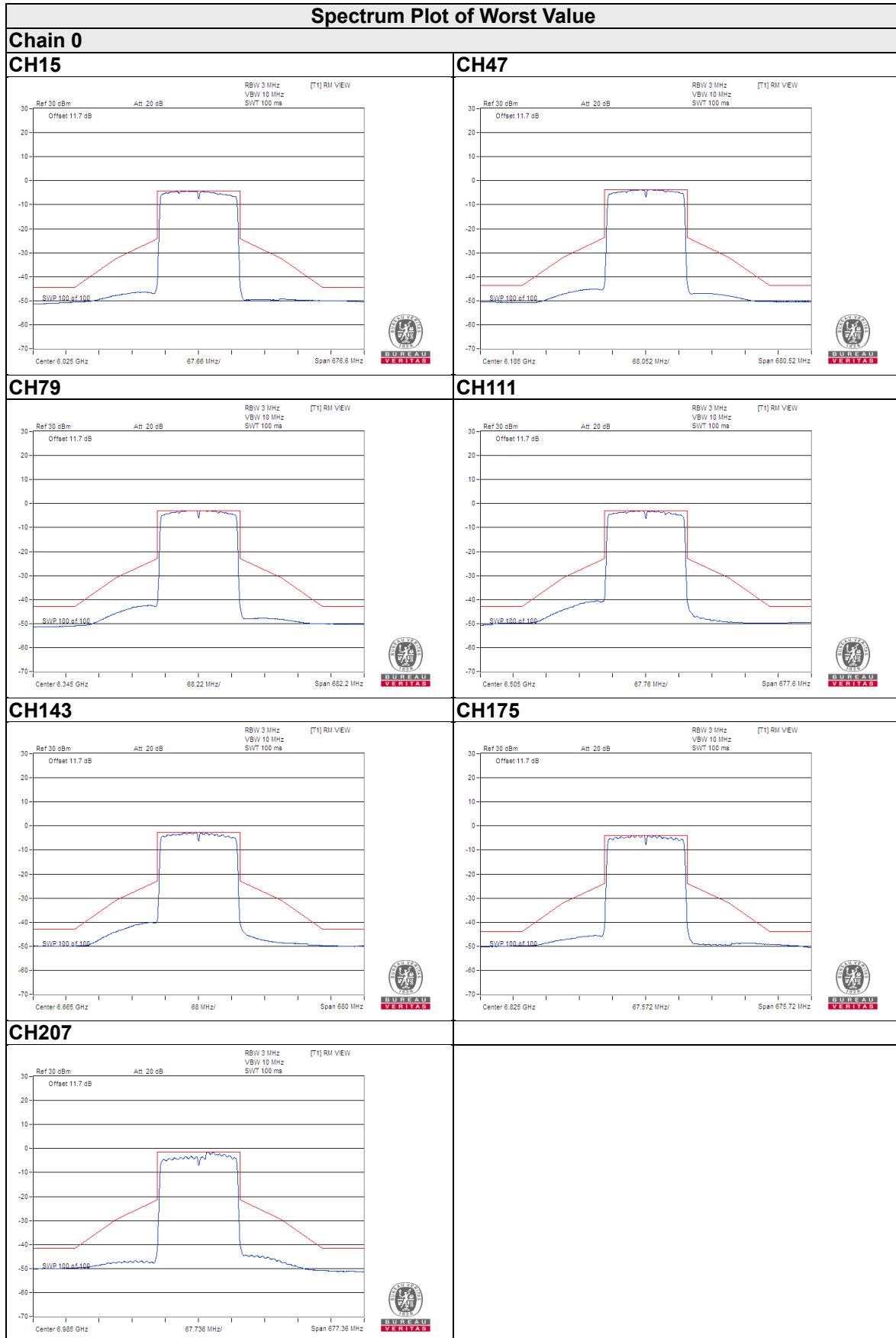

### Spectrum Plot of Worst Value

#### Chain 1

#### CH15

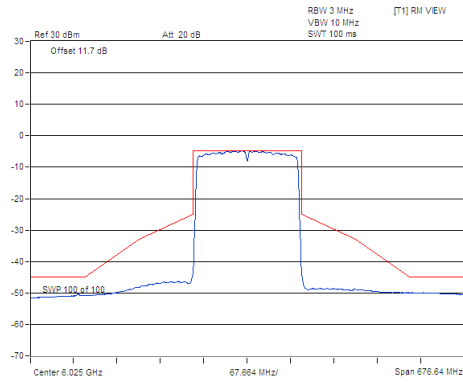

#### CH47

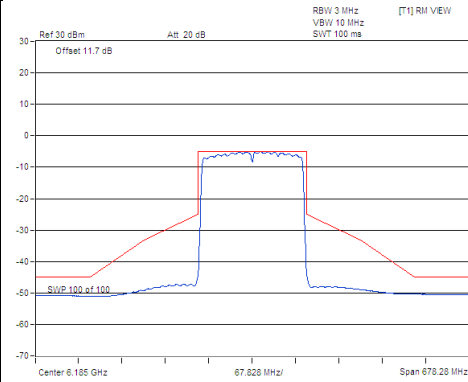

#### CH79

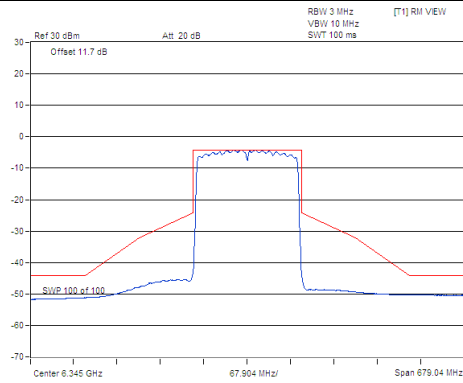

#### CH111

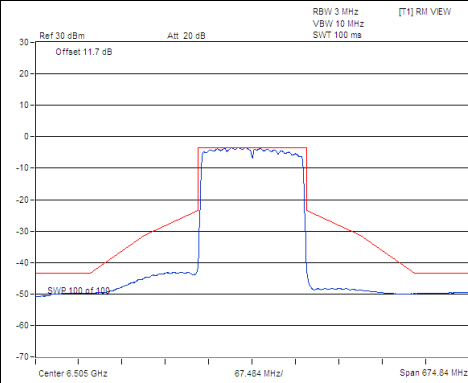

#### CH143

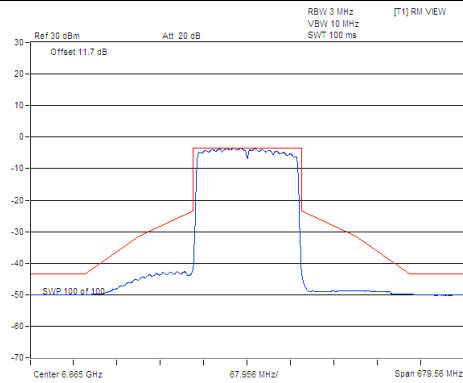

#### CH175

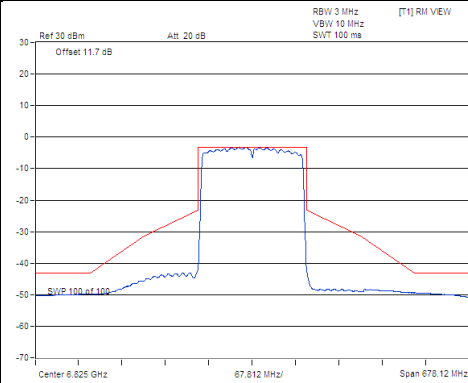

#### CH207

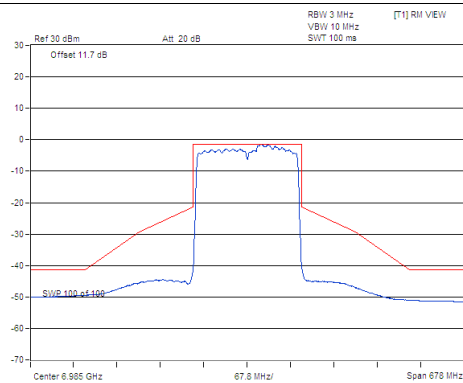

### 4.3 Conducted Emission Measurement

#### 4.3.1 Limits of Conducted Emission Measurement

Frequency (MHz)	Conducted Limit (dBuV)	
	Quasi-peak	Average
0.15 - 0.5	66 - 56	56 - 46
0.50 - 5.0	56	46
5.0 - 30.0	60	50

Note: 1. The lower limit shall apply at the transition frequencies.

2. The limit decreases in line with the logarithm of the frequency in the range of 0.15 to 0.50MHz.

#### 4.3.2 Test Instruments

Description & Manufacturer	Model No.	Serial No.	Cal. Date	Cal. Due
Test Receiver ROHDE & SCHWARZ	ESR3	102783	Dec. 21, 2020	Dec. 20, 2021
RF signal cable (with 10dB PAD) Woken	5D-FB	Cable-cond2-01	Sep. 04, 2021	Sep. 03, 2022
LISN/AMN ROHDE & SCHWARZ (EUT)	ESH2-Z5	100100	Jan. 28, 2021	Jan. 27, 2022
LISN/AMN ROHDE & SCHWARZ (Peripheral)	ESH3-Z5	100312	Sep. 17, 2021	Sep. 16, 2022
Software ADT	BV ADT_Cond_ V7.3.7.4	NA	NA	NA

Note: 1. The calibration interval of the above test instruments is 12 months and the calibrations are traceable to NML/ROC and NIST/USA.

2. The test was performed in HwaYa Shielded Room 2 (Conduction 2).

3. The VCCI Site Registration No. is C-12047.

4. Test Date: 2021/10/06

#### 4.3.3 Test Procedure

- The EUT was placed 0.4 meters from the conducting wall of the shielded room with EUT being connected to the power mains through a line impedance stabilization network (LISN). Other support units were connected to the power mains through another LISN. The two LISNs provide 50 ohm/ 50uH of coupling impedance for the measuring instrument.
- Both lines of the power mains connected to the EUT were checked for maximum conducted interference.
- The frequency range from 150kHz to 30MHz was searched. Emission levels under (Limit - 20dB) was not recorded.

**NOTE:** All modes of operation were investigated and the worst-case emissions are reported.

#### 4.3.4 Test Setup

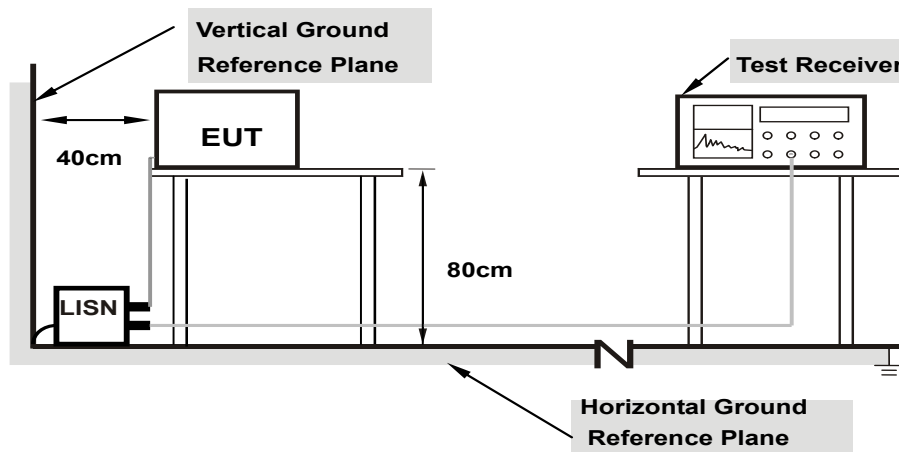

**Note: 1. Support units were connected to second LISN.**

For the actual test configuration please refer to the attached file (Test Setup Photo) 20120637-6  
**from other units and other metal planes**

#### 4.3.5 EUT Operating Condition

Same as 4.1.6.

#### 4.3.6 Test Results

Frequency Range	150kHz ~ 30MHz	Detector Function & Resolution Bandwidth	Quasi-Peak (QP) / Average (AV), 9kHz
Input Power	120Vac, 60Hz	Environmental Conditions	25 °C, 75% RH
Tested by	Rex Wang		

Phase Of Power : Line (L)										
No	Frequency (MHz)	Correction Factor (dB)	Reading Value (dBuV)		Emission Level (dBuV)		Limit (dBuV)		Margin (dB)	
			Q.P.	AV.	Q.P.	AV.	Q.P.	AV.	Q.P.	AV.
1	0.16200	10.13	37.38	7.14	47.51	17.27	65.36	55.36	-17.85	-38.09
2	0.29800	10.18	23.09	3.52	33.27	13.70	60.30	50.30	-27.03	-36.60
3	0.38929	10.22	24.02	6.81	34.24	17.03	58.08	48.08	-23.84	-31.05
4	1.47400	10.32	27.68	6.94	38.00	17.26	56.00	46.00	-18.00	-28.74
5	3.42200	10.38	31.85	14.29	42.23	24.67	56.00	46.00	-13.77	-21.33
6	11.29000	10.52	31.30	21.15	41.82	31.67	60.00	50.00	-18.18	-18.33

#### Remarks:

1. Q.P. and AV. are abbreviations of quasi-peak and average individually.
2. The emission levels of other frequencies were very low against the limit.
3. Margin value = Emission level – Limit value
4. Correction factor = Insertion loss + Cable loss
5. Emission Level = Correction Factor + Reading Value

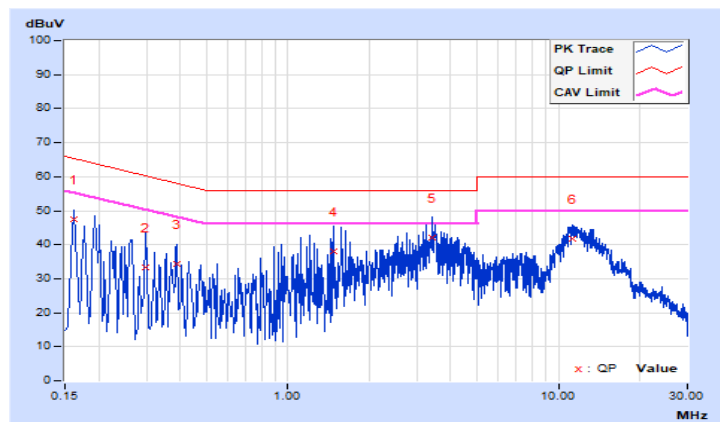

Frequency Range	150kHz ~ 30MHz	Detector Function & Resolution Bandwidth	Quasi-Peak (QP) / Average (AV), 9kHz
Input Power	120Vac, 60Hz	Environmental Conditions	25 °C, 75% RH
Tested by	Rex Wang		

Phase Of Power : Neutral (N)										
No	Frequency (MHz)	Correction Factor (dB)	Reading Value (dBuV)		Emission Level (dBuV)		Limit (dBuV)		Margin (dB)	
			Q.P.	AV.	Q.P.	AV.	Q.P.	AV.	Q.P.	AV.
1	0.15800	10.14	39.32	7.98	49.46	18.12	65.57	55.57	-16.11	-37.45
2	0.19800	10.17	39.56	19.96	49.73	30.13	63.69	53.69	-13.96	-23.56
3	1.34600	10.31	24.47	8.47	34.78	18.78	56.00	46.00	-21.22	-27.22
4	1.77400	10.34	23.17	6.62	33.51	16.96	56.00	46.00	-22.49	-29.04
5	3.34200	10.39	31.22	16.33	41.61	26.72	56.00	46.00	-14.39	-19.28
<b>6</b>	<b>11.31400</b>	<b>10.62</b>	<b>36.64</b>	<b>26.34</b>	<b>47.26</b>	<b>36.96</b>	<b>60.00</b>	<b>50.00</b>	<b>-12.74</b>	<b>-13.04</b>

Remarks:

1. Q.P. and AV. are abbreviations of quasi-peak and average individually.
2. The emission levels of other frequencies were very low against the limit.
3. Margin value = Emission level – Limit value
4. Correction factor = Insertion loss + Cable loss
5. Emission Level = Correction Factor + Reading Value

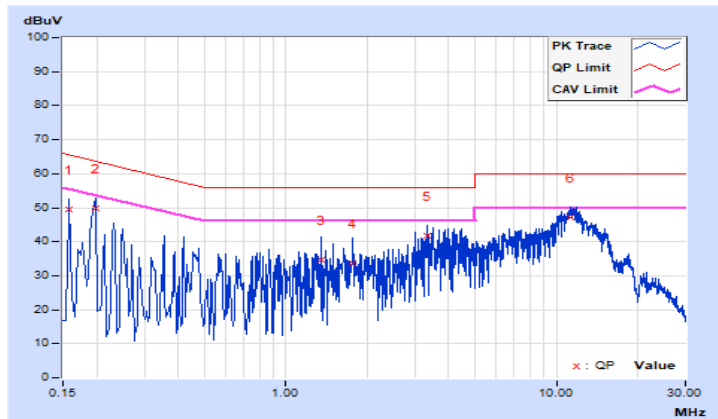

## 4.4 Transmit Power Measurement

### 4.4.1 Limits of Transmit Power Measurement

Operation Band	EUT Category	Limit
		Max Average Power
U-NII-5 U-NII-6 U-NII-7 U-NII-8	Client Devices ( controlled of an indoor AP )	EIRP 24 dBm

Per KDB 662911 Method of conducted output power measurement on IEEE 802.11 devices,

Array Gain = 0 dB (i.e., no array gain) for  $N_{ANT} \leq 4$ ;

Array Gain = 0 dB (i.e., no array gain) for channel widths  $\geq 40$  MHz for any  $N_{ANT}$ ;

Array Gain =  $5 \log(N_{ANT}/N_{SS})$  dB or 3 dB, whichever is less for 20-MHz channel widths with  $N_{ANT} \geq 5$ .

For power measurements on all other devices: Array Gain =  $10 \log(N_{ANT}/N_{SS})$  dB.

### 4.4.2 Test Setup

#### FOR POWER OUTPUT MEASUREMENT

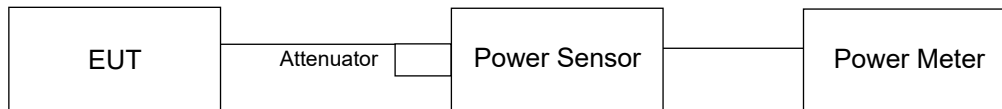

### 4.4.3 Test Instruments

Refer to section 4.1.2 to get information of above instrument.

### 4.4.4 Test Procedure

#### FOR POWER OUTPUT MEASUREMENT

Method PM is used to perform output power measurement, trigger and gating function of wide band power meter is enabled to measure max output power of TX on burst. Duty factor is not added to measured value.

### 4.4.5 EUT Operating Condition

The software provided by client to enable the EUT under transmission condition continuously at lowest, middle and highest channel frequencies individually.

## 4.4.6 Test Result

## 802.11a

Chan.	Chan. Freq. (MHz)	Average Power (dBm)		Total Power (mW)	Total Power (dBm)	Max. Gain (dBi)	EIRP (mW)	EIRP (dBm)	EIRP Limit (dBm)	Pass / Fail
		Chain 0	Chain 1							
1	5955	4.67	4.26	5.598	7.48	2	8.872	9.48	24	Pass
45	6175	4.30	3.66	5.014	7	2	7.943	9.00	24	Pass
93	6415	3.86	4.02	4.956	6.95	2	7.852	8.95	24	Pass
97	6435	4.32	4.98	5.852	7.67	1.5	8.26	9.17	24	Pass
105	6475	4.33	4.83	5.751	7.6	1.5	8.128	9.10	24	Pass
113	6515	4.84	4.54	5.892	7.7	1.5	8.318	9.20	24	Pass
117	6535	4.81	4.53	5.865	7.68	1.5	8.279	9.18	24	Pass
149	6695	4.01	4.19	5.142	7.11	1.5	7.261	8.61	24	Pass
181	6855	4.07	4.76	5.545	7.44	1.5	7.834	8.94	24	Pass
185	6875	4.26	4.59	5.544	7.44	1	6.982	8.44	24	Pass
209	6995	4.48	5.01	5.975	7.76	1	7.516	8.76	24	Pass
233	7115	6.65	3.63	6.931	8.41	1	8.73	9.41	24	Pass

## 802.11ax (HE20)

Chan.	Chan. Freq. (MHz)	Average Power (dBm)		Total Power (mW)	Total Power (dBm)	Max. Gain (dBi)	EIRP (mW)	EIRP (dBm)	EIRP Limit (dBm)	Pass / Fail
		Chain 0	Chain 1							
1	5955	4.61	4.53	5.729	7.58	2	9.078	9.58	24	Pass
45	6175	4.63	4.00	5.416	7.34	2	8.59	9.34	24	Pass
93	6415	4.03	4.59	5.407	7.33	2	8.57	9.33	24	Pass
97	6435	4.29	5.11	5.929	7.73	1.5	8.375	9.23	24	Pass
105	6475	4.02	4.55	5.374	7.3	1.5	7.586	8.80	24	Pass
113	6515	4.61	4.54	5.735	7.59	1.5	8.11	9.09	24	Pass
117	6535	4.59	4.63	5.781	7.62	1.5	8.166	9.12	24	Pass
149	6695	4.38	4.97	5.882	7.7	1.5	8.318	9.20	24	Pass
181	6855	3.93	5.05	5.671	7.54	1.5	8.017	9.04	24	Pass
185	6875	4.64	5.28	6.284	7.98	1	7.907	8.98	24	Pass
209	6995	4.90	5.89	6.972	8.43	1	8.77	9.43	24	Pass
233	7115	-3.98	-2.95	0.9069	-0.42	1	1.143	0.58	24	Pass



**802.11ax (HE40)**

Chan.	Chan. Freq. (MHz)	Average Power (dBm)		Total Power (mW)	Total Power (dBm)	Max. Gain (dBi)	EIRP (mW)	EIRP (dBm)	EIRP Limit (dBm)	Pass / Fail
		Chain 0	Chain 1							
3	5965	6.81	7.24	10.094	10.04	2	15.996	12.04	24	Pass
43	6165	6.83	6.25	9.036	9.56	2	14.322	11.56	24	Pass
91	6405	7.03	7.93	11.255	10.51	2	17.824	12.51	24	Pass
99	6445	7.09	7.56	10.818	10.34	1.5	15.276	11.84	24	Pass
107	6485	7.34	8.18	11.997	10.79	1.5	16.943	12.29	24	Pass
115	6525	7.61	7.87	11.891	10.75	1.5	16.788	12.25	24	Pass
123	6565	7.67	7.44	11.394	10.57	1.5	16.106	12.07	24	Pass
155	6725	7.10	8.01	11.453	10.59	1.5	16.181	12.09	24	Pass
179	6845	7.05	8.15	11.601	10.64	1.5	16.368	12.14	24	Pass
187	6885	7.88	8.11	12.609	11.01	1	15.885	12.01	24	Pass
211	7005	8.12	8.59	13.714	11.37	1	17.258	12.37	24	Pass
227	7085	9.31	7.70	14.419	11.59	1	18.155	12.59	24	Pass

**802.11ax (HE80)**

Chan.	Chan. Freq. (MHz)	Average Power (dBm)		Total Power (mW)	Total Power (dBm)	Max. Gain (dBi)	EIRP (mW)	EIRP (dBm)	EIRP Limit (dBm)	Pass / Fail
		Chain 0	Chain 1							
7	5985	10.65	9.67	20.883	13.2	2	33.113	15.20	24	Pass
39	6145	9.35	10.03	18.679	12.71	2	29.58	14.71	24	Pass
87	6385	10.32	9.45	19.575	12.92	2	31.046	14.92	24	Pass
103	6465	9.83	10.65	21.231	13.27	1.5	29.992	14.77	24	Pass
119	6545	10.53	10.41	22.288	13.48	1.5	31.477	14.98	24	Pass
151	6705	9.91	10.49	20.989	13.22	1.5	29.648	14.72	24	Pass
183	6865	10.06	10.44	21.205	13.26	1.5	29.923	14.76	24	Pass
199	6945	12.18	9.32	25.07	13.99	1	31.55	14.99	24	Pass
215	7025	9.67	12.01	25.154	14.01	1	31.696	15.01	24	Pass

### 802.11ax (HE160)

Chan.	Chan. Freq. (MHz)	Average Power (dBm)		Total Power (mW)	Total Power (dBm)	Max. Gain (dBi)	EIRP (mW)	EIRP (dBm)	EIRP Limit (dBm)	Pass / Fail
		Chain 0	Chain 1							
15	6025	12.93	12.46	37.253	15.71	2	59.02	17.71	24	Pass
47	6185	13.80	12.25	40.776	16.1	2	64.565	18.10	24	Pass
79	6345	13.86	12.54	<b>42.269</b>	<b>16.26</b>	2	66.988	18.26	24	Pass
111	6505	14.02	13.41	<b>47.163</b>	<b>16.74</b>	1.5	66.681	18.24	24	Pass
143	6665	14.13	13.54	<b>48.476</b>	<b>16.86</b>	1.5	68.549	18.36	24	Pass
175	6825	13.12	13.84	44.722	16.51	1.5	63.241	18.01	24	Pass
207	6985	13.53	14.19	<b>48.785</b>	<b>16.88</b>	1	61.376	17.88	24	Pass

### 20MHz Preamble

#### 802.11ax (RU26)

Chan.	Chan. Freq. (MHz)	Average Power (dBm)		Total Power (mW)	Total Power (dBm)	Max. Gain (dBi)	EIRP (mW)	EIRP (dBm)	EIRP Limit (dBm)	Pass / Fail
		Chain 0	Chain 1							
1	5955	-5.27	-4.62	0.6423	-1.92	2	1.019	0.08	24	Pass
45	6175	-4.83	-5.92	0.5847	-2.33	2	0.927	-0.33	24	Pass
93	6415	-5.65	-4.83	0.6011	-2.21	2	0.953	-0.21	24	Pass
97	6435	-5.41	-4.79	0.6196	-2.08	1.5	0.875	-0.58	24	Pass
105	6475	-5.60	-4.68	0.6158	-2.11	1.5	0.869	-0.61	24	Pass
113	6515	-5.76	-4.63	0.6098	-2.15	1.5	0.861	-0.65	24	Pass
117	6535	-4.71	-5.33	0.6312	-2	1.5	0.891	-0.50	24	Pass
149	6695	-4.80	-5.67	0.6022	-2.2	1.5	0.851	-0.70	24	Pass
181	6855	-5.74	-4.86	0.5933	-2.27	1.5	0.838	-0.77	24	Pass
185	6875	-4.10	-3.67	0.8186	-0.87	1	1.03	0.13	24	Pass
209	6995	-3.18	-4.59	0.8284	-0.82	1	1.042	0.18	24	Pass
233	7115	-11.55	-10.15	0.16659	-7.78	1	0.21	-6.78	24	Pass

**802.11ax (RU52)**

Chan.	Chan. Freq. (MHz)	Average Power (dBm)		Total Power (mW)	Total Power (dBm)	Max. Gain (dBi)	EIRP (mW)	EIRP (dBm)	EIRP Limit (dBm)	Pass / Fail
		Chain 0	Chain 1							
1	5955	-1.56	-1.48	1.4094	1.49	2	2.234	3.49	24	Pass
45	6175	-0.91	-2.91	1.3226	1.21	2	2.094	3.21	24	Pass
93	6415	-1.76	-1.40	1.3912	1.43	2	2.203	3.43	24	Pass
97	6435	-1.82	-1.67	1.3384	1.27	1.5	1.892	2.77	24	Pass
105	6475	-2.36	-1.45	1.2969	1.13	1.5	1.832	2.63	24	Pass
113	6515	-2.34	-1.45	1.2996	1.14	1.5	1.837	2.64	24	Pass
117	6535	-1.36	-2.26	1.3254	1.22	1.5	1.871	2.72	24	Pass
149	6695	-1.52	-2.34	1.2881	1.1	1.5	1.82	2.60	24	Pass
181	6855	-2.09	-1.18	1.3801	1.4	1.5	1.95	2.90	24	Pass
185	6875	-1.87	-1.34	1.3846	1.41	1	1.742	2.41	24	Pass
209	6995	-1.21	-2.60	1.3064	1.16	1	1.644	2.16	24	Pass
233	7115	-10.37	-8.71	0.22642	-6.45	1	0.285	-5.45	24	Pass

**802.11ax (RU106)**

Chan.	Chan. Freq. (MHz)	Average Power (dBm)		Total Power (mW)	Total Power (dBm)	Max. Gain (dBi)	EIRP (mW)	EIRP (dBm)	EIRP Limit (dBm)	Pass / Fail
		Chain 0	Chain 1							
1	5955	0.04	1.43	2.399	3.8	2	3.802	5.80	24	Pass
45	6175	1.24	-0.69	2.1836	3.39	2	3.459	5.39	24	Pass
93	6415	0.56	0.98	2.391	3.79	2	3.793	5.79	24	Pass
97	6435	0.71	0.83	2.388	3.78	1.5	3.373	5.28	24	Pass
105	6475	0.17	1.03	2.308	3.63	1.5	3.258	5.13	24	Pass
113	6515	0.26	0.98	2.315	3.65	1.5	3.273	5.15	24	Pass
117	6535	1.02	0.39	2.359	3.73	1.5	3.334	5.23	24	Pass
149	6695	1.01	0.15	2.297	3.61	1.5	3.243	5.11	24	Pass
181	6855	1.02	0.12	2.293	3.6	1.5	3.236	5.10	24	Pass
185	6875	0.20	0.71	2.225	3.47	1	2.799	4.47	24	Pass
209	6995	1.11	-0.12	2.264	3.55	1	2.851	4.55	24	Pass
233	7115	-8.63	-7.26	0.325	-4.88	1	0.409	-3.88	24	Pass

**802.11ax (RU242)**

Chan.	Chan. Freq. (MHz)	Average Power (dBm)		Total Power (mW)	Total Power (dBm)	Max. Gain (dBi)	EIRP (mW)	EIRP (dBm)	EIRP Limit (dBm)	Pass / Fail
		Chain 0	Chain 1							
1	5955	4.57	4.50	5.683	7.55	2	9.016	9.55	24	Pass
45	6175	4.55	4.01	5.369	7.3	2	8.511	9.30	24	Pass
93	6415	4.01	4.53	5.356	7.29	2	8.492	9.29	24	Pass
97	6435	4.22	4.81	5.669	7.54	1.5	8.017	9.04	24	Pass
105	6475	3.98	4.43	5.274	7.22	1.5	7.447	8.72	24	Pass
113	6515	4.55	4.48	5.656	7.53	1.5	7.998	9.03	24	Pass
117	6535	4.12	4.78	5.588	7.47	1.5	7.889	8.97	24	Pass
149	6695	4.14	4.67	5.525	7.42	1.5	7.798	8.92	24	Pass
181	6855	3.90	4.81	5.482	7.39	1.5	7.745	8.89	24	Pass
185	6875	4.14	4.71	5.552	7.44	1	6.982	8.44	24	Pass
209	6995	4.01	4.73	5.489	7.39	1	6.902	8.39	24	Pass
233	7115	-2.97	-3.78	0.9235	-0.35	1	1.161	0.65	24	Pass

**40MHz Preamble**
**802.11ax (RU484)**

Chan.	Chan. Freq. (MHz)	Average Power (dBm)		Total Power (mW)	Total Power (dBm)	Max. Gain (dBi)	EIRP (mW)	EIRP (dBm)	EIRP Limit (dBm)	Pass / Fail
		Chain 0	Chain 1							
3	5965	6.71	7.19	9.924	9.97	2	15.74	11.97	24	Pass
43	6165	6.81	6.21	8.976	9.53	2	14.223	11.53	24	Pass
91	6405	6.03	6.93	8.94	9.51	2	14.158	11.51	24	Pass
99	6445	6.56	7.06	9.611	9.83	1.5	13.583	11.33	24	Pass
107	6485	6.32	7.16	9.485	9.77	1.5	13.397	11.27	24	Pass
115	6525	6.56	6.82	9.337	9.7	1.5	13.183	11.20	24	Pass
123	6565	6.66	6.42	9.02	9.55	1.5	12.735	11.05	24	Pass
155	6725	6.12	6.98	9.081	9.58	1.5	12.823	11.08	24	Pass
179	6845	6.03	7.12	9.161	9.62	1.5	12.942	11.12	24	Pass
187	6885	6.35	6.67	8.96	9.52	1	11.272	10.52	24	Pass
211	7005	6.64	7.05	9.683	9.86	1	12.19	10.86	24	Pass
227	7085	9.28	7.56	14.174	11.51	1	17.824	12.51	24	Pass

### 80MHz Preamble

#### 802.11ax (RU996)

Chan.	Chan. Freq. (MHz)	Average Power (dBm)		Total Power (mW)	Total Power (dBm)	Max. Gain (dBi)	EIRP (mW)	EIRP (dBm)	EIRP Limit (dBm)	Pass / Fail
		Chain 0	Chain 1							
7	5985	10.54	9.45	20.134	13.04	2	31.915	15.04	24	Pass
39	6145	9.33	9.91	18.365	12.64	2	29.107	14.64	24	Pass
87	6385	10.28	9.42	19.416	12.88	2	30.761	14.88	24	Pass
103	6465	9.32	10.11	18.807	12.74	1.5	26.546	14.24	24	Pass
119	6545	10.01	9.92	19.841	12.98	1.5	28.054	14.48	24	Pass
151	6705	9.40	9.93	18.55	12.68	1.5	26.182	14.18	24	Pass
183	6865	9.51	9.92	18.751	12.73	1.5	26.485	14.23	24	Pass
199	6945	11.11	8.26	19.611	12.92	1	24.66	13.92	24	Pass
215	7025	9.67	12.01	25.154	14.01	1	31.696	15.01	24	Pass

### 160MHz Preamble

#### 802.11ax (RU996\*2)

Chan.	Chan. Freq. (MHz)	Average Power (dBm)		Total Power (mW)	Total Power (dBm)	Max. Gain (dBi)	EIRP (mW)	EIRP (dBm)	EIRP Limit (dBm)	Pass / Fail
		Chain 0	Chain 1							
15	6025	12.93	12.46	37.253	15.71	2	59.02	17.71	24	Pass
47	6185	13.80	12.25	40.776	16.1	2	64.565	18.10	24	Pass
79	6345	13.86	12.54	<b>42.269</b>	<b>16.26</b>	2	66.988	18.26	24	Pass
111	6505	14.02	13.41	<b>47.163</b>	<b>16.74</b>	1.5	66.681	18.24	24	Pass
143	6665	14.13	13.54	<b>48.476</b>	<b>16.86</b>	1.5	68.549	18.36	24	Pass
175	6825	13.12	13.84	44.722	16.51	1.5	63.241	18.01	24	Pass
207	6985	13.53	14.19	<b>48.785</b>	<b>16.88</b>	1	61.376	17.88	24	Pass

## 4.5 Emission Bandwidth Measurement

### 4.5.1 Test Setup

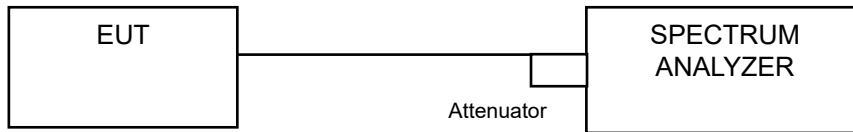

### 4.5.2 Test Instruments

Refer to section 4.1.2 to get information of above instrument.

### 4.5.3 Test Procedure

#### FOR 99% OCCUPIED BANDWIDTH

The transmitter output was connected to the spectrum analyzer through an attenuator. The bandwidth of the fundamental frequency was measured by spectrum analyzer with resolution bandwidth in the range of 1% to 5% of the anticipated emission bandwidth, and a video bandwidth at least 3x the resolution bandwidth and set the detector to SAMPLE. The width of a frequency band such that, below the lower and above the upper frequency limits, the mean powers emitted are each equal to a specified percentage 0.5 %of the total mean power of a given emission.

#### FOR 26dB BANDWIDTH

- Set RBW = approximately 1% of the emission bandwidth.
- Set the VBW > RBW.
- Detector = Peak.
- Trace mode = max hold.
- Measure the maximum width of the emission that is 26 dB down from the peak of the emission. Compare this with the RBW setting of the analyzer. Readjust RBW and repeat measurement as needed until the RBW/EBW ratio is approximately 1%.

#### 4.5.4 Test Results

#### 99% Occupied Bandwidth:

#### 802.11a

Channel	Frequency (MHz)	Occupied Bandwidth (MHz)		
		Chain 0	Chain 1	Limit (MHz)
1	5955	16.44	16.44	320
45	6175	16.44	16.44	320
93	6415	16.44	16.44	320
97	6435	16.56	16.44	320
105	6475	16.56	16.44	320
113	6515	16.56	16.56	320
117	6535	16.44	16.44	320
149	6695	16.56	16.44	320
181	6855	16.56	16.44	320
185	6875	16.44	16.44	320
209	6995	16.44	16.44	320
233	7115	16.44	16.44	320

#### 802.11ax (HE20)

Channel	Frequency (MHz)	Occupied Bandwidth (MHz)		
		Chain 0	Chain 1	Limit (MHz)
1	5955	18.94	18.94	320
45	6175	18.96	19.08	320
93	6415	19.08	18.96	320
97	6435	18.96	19.08	320
105	6475	18.96	18.96	320
113	6515	18.96	18.96	320
117	6535	18.96	19.08	320
149	6695	18.96	19.08	320
181	6855	18.96	19.08	320
185	6875	18.96	18.96	320
209	6995	18.96	19.08	320
233	7115	19.08	19.08	320

**802.11ax (HE40)**

Channel	Frequency (MHz)	Occupied Bandwidth (MHz)		
		Chain 0	Chain 1	Limit (MHz)
3	5965	37.89	37.89	320
43	6165	38.16	38.16	320
91	6405	37.92	38.16	320
99	6445	37.92	38.16	320
107	6485	38.16	37.68	320
115	6525	38.16	38.16	320
123	6565	38.16	38.16	320
155	6725	37.92	38.16	320
179	6845	37.92	37.92	320
187	6885	37.92	38.16	320
211	7005	37.92	38.16	320
227	7085	38.16	37.89	320

**802.11ax (HE80)**

Channel	Frequency (MHz)	Occupied Bandwidth (MHz)		
		Chain 0	Chain 1	Limit (MHz)
7	5985	77.31	77.31	320
39	6145	77.31	77.28	320
87	6385	77.76	77.28	320
103	6465	77.28	76.80	320
119	6545	77.28	77.76	320
151	6705	77.28	77.28	320
183	6865	77.28	77.28	320
199	6945	77.28	77.28	320
215	7025	77.76	77.76	320

**802.11ax (HE160)**

Channel	Frequency (MHz)	Occupied Bandwidth (MHz)		
		Chain 0	Chain 1	Limit (MHz)
15	6025	156.52	156.52	320
47	6185	156.48	156.48	320
79	6345	156.48	156.48	320
111	6505	156.48	156.48	320
143	6665	156.48	156.48	320
175	6825	156.48	156.48	320
207	6985	156.48	156.48	320



### Spectrum Plot of Max. Value

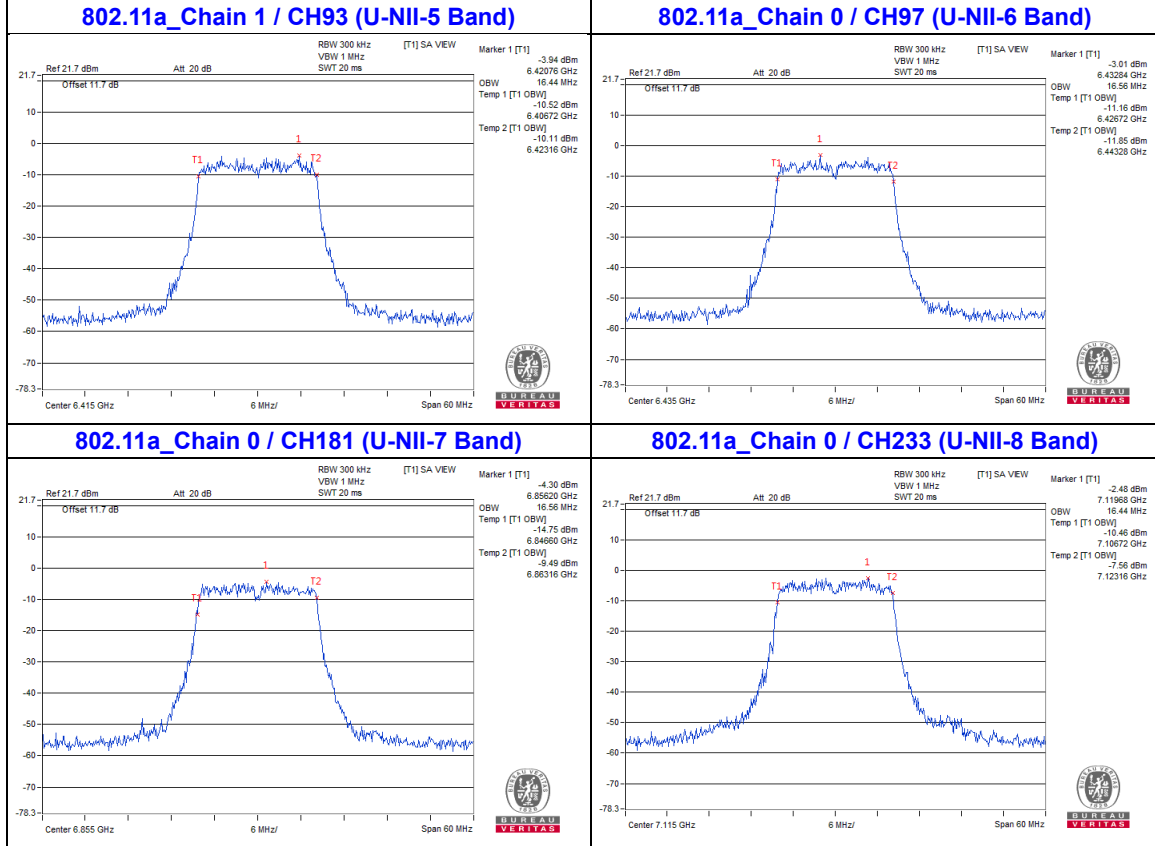

### Spectrum Plot of Max. Value

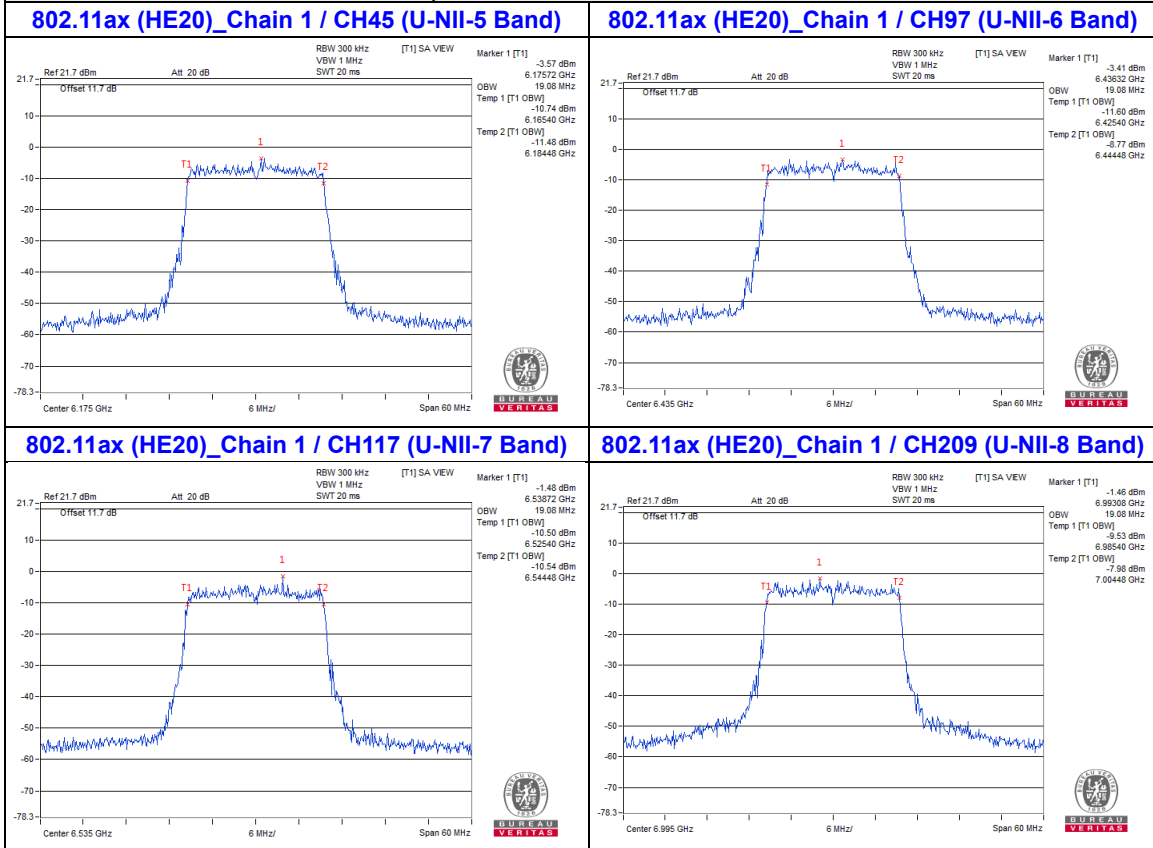

### Spectrum Plot of Max. Value

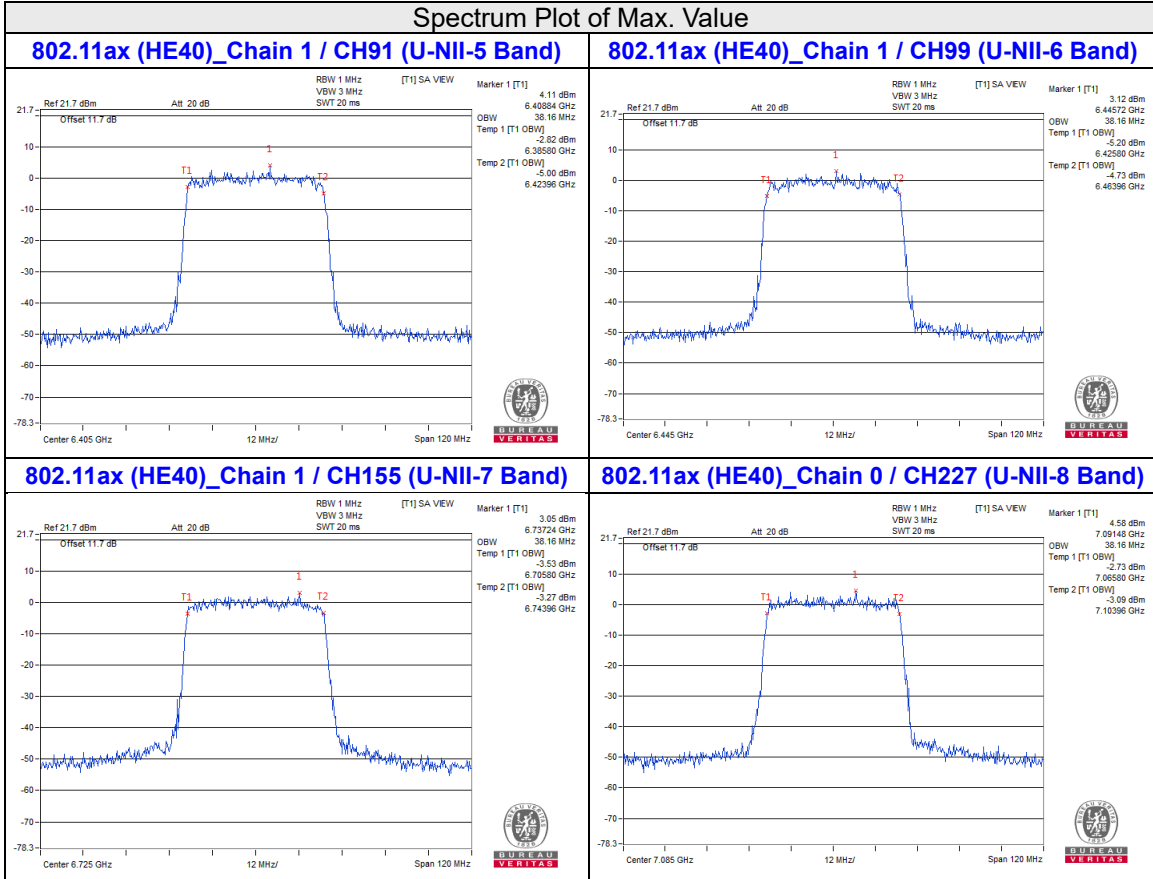

### Spectrum Plot of Max. Value

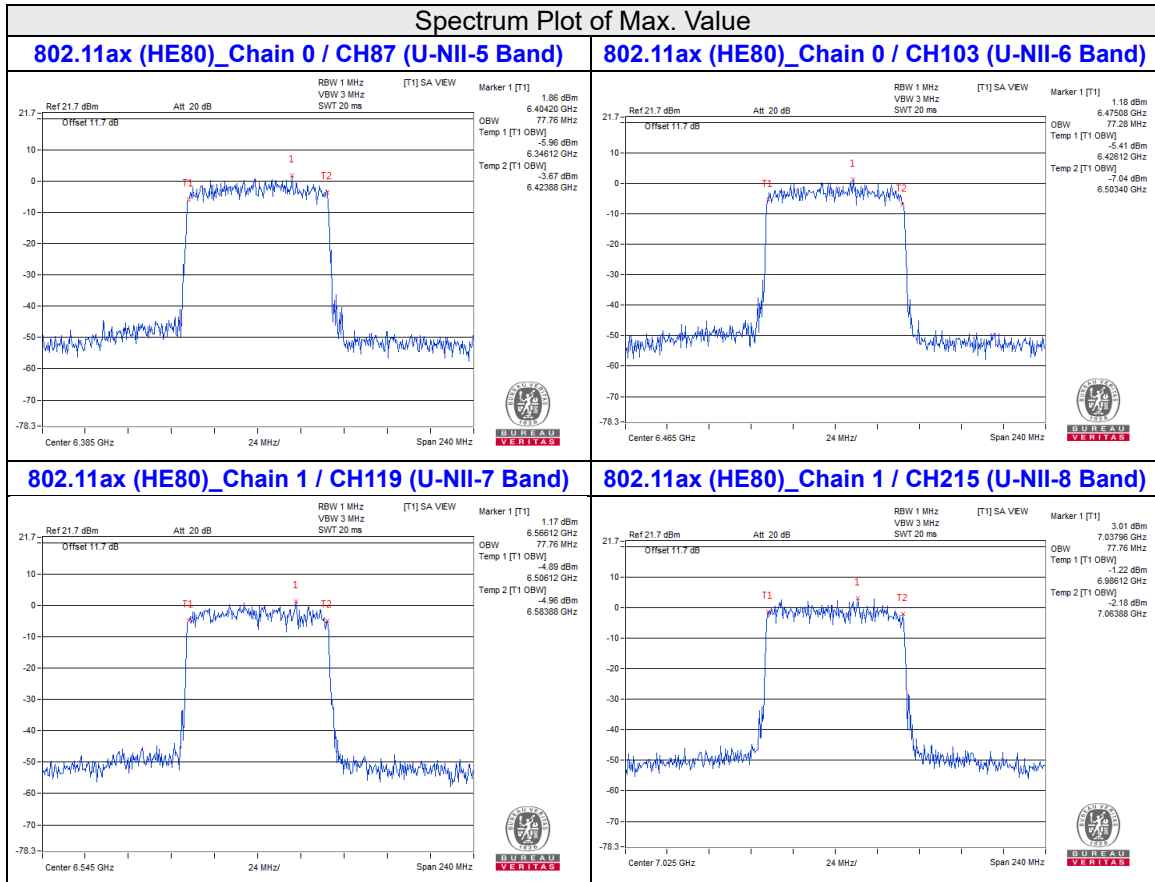

### Spectrum Plot of Max. Value

**802.11ax (HE160)\_Chain 1 / CH15 (U-NII-5 Band)**

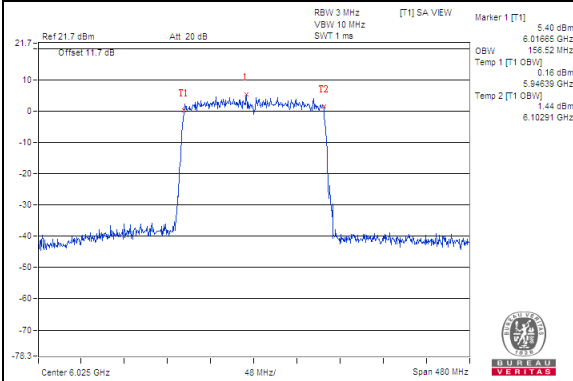

**802.11ax (HE160)\_Chain 1 / CH111 (U-NII-6 Band)**

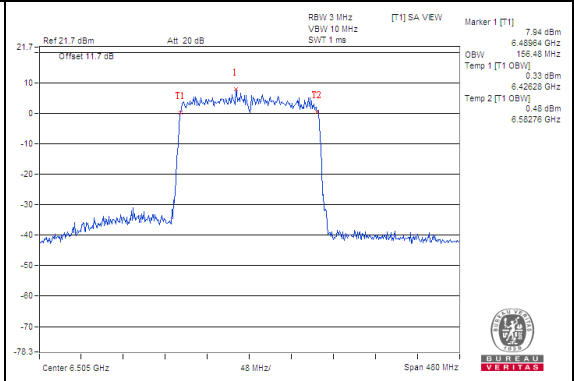

**802.11ax (HE160)\_Chain 0 / CH143 (U-NII-7 Band)**

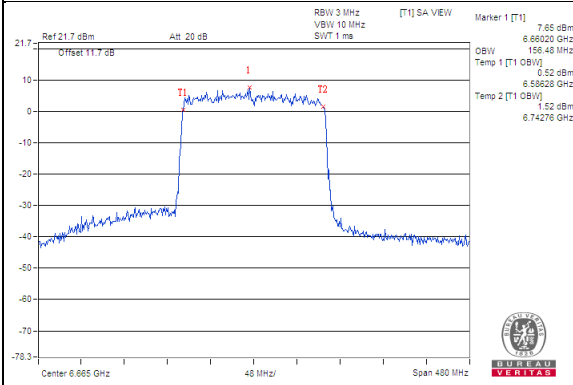

**802.11ax (HE160)\_Chain 0 / CH207 (U-NII-8 Band)**

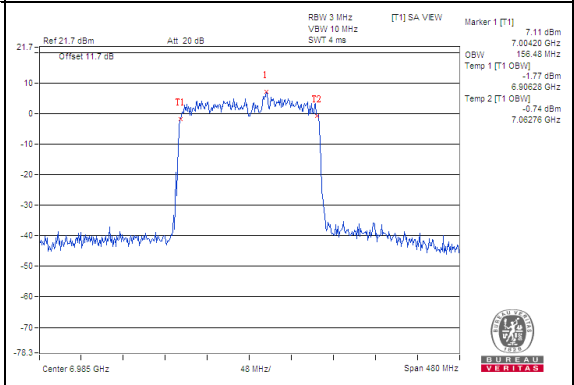

**26dB Bandwidth:**
**802.11a**

Channel	Frequency (MHz)	26dB Bandwidth (MHz)		
		Chain0	Chain1	Limit (MHz)
1	5955	19.41	19.07	320
45	6175	19.58	19.22	320
93	6415	19.46	19.34	320
97	6435	19.60	19.20	320
105	6475	19.56	19.17	320
113	6515	19.47	19.14	320
117	6535	19.54	19.30	320
149	6695	19.56	19.14	320
181	6855	19.64	19.17	320
185	6875	19.54	19.07	320
209	6995	19.41	19.26	320
233	7115	19.50	19.18	320

**802.11ax (HE20)**

Channel	Frequency (MHz)	26dB Bandwidth (MHz)		
		Chain0	Chain1	Limit (MHz)
1	5955	21.57	21.38	320
45	6175	21.52	21.45	320
93	6415	21.41	21.56	320
97	6435	21.38	21.46	320
105	6475	21.56	21.56	320
113	6515	21.60	21.32	320
117	6535	21.49	21.56	320
149	6695	21.41	21.71	320
181	6855	21.48	21.71	320
185	6875	21.43	21.57	320
209	6995	21.24	21.59	320
233	7115	21.58	21.49	320

**802.11ax (HE40)**

Channel	Frequency (MHz)	26dB Bandwidth (MHz)		
		Chain0	Chain1	Limit (MHz)
3	5965	41.85	42.08	320
43	6165	42.31	41.90	320
91	6405	41.79	42.32	320
99	6445	42.28	42.21	320
107	6485	42.27	42.03	320
115	6525	41.88	42.31	320
123	6565	42.02	41.90	320
155	6725	42.19	42.17	320
179	6845	41.78	42.11	320
187	6885	41.96	42.20	320
211	7005	42.21	42.23	320
227	7085	42.00	41.70	320

**802.11ax (HE80)**

Channel	Frequency (MHz)	26dB Bandwidth (MHz)		
		Chain0	Chain1	Limit (MHz)
7	5985	83.17	82.94	320
39	6145	83.30	83.87	320
87	6385	83.24	83.41	320
103	6465	83.56	83.24	320
119	6545	83.08	82.57	320
151	6705	83.44	83.76	320
183	6865	83.19	83.22	320
199	6945	83.46	83.45	320
215	7025	83.48	83.38	320

**802.11ax (HE160)**

Channel	Frequency (MHz)	26dB Bandwidth (MHz)		
		Chain0	Chain1	Limit (MHz)
15	6025	169.15	169.16	320
47	6185	170.13	169.57	320
79	6345	170.55	169.76	320
111	6505	169.40	168.71	320
143	6665	170.00	169.89	320
175	6825	168.93	169.53	320
207	6985	169.34	169.50	320

### Spectrum Plot of Max. Value

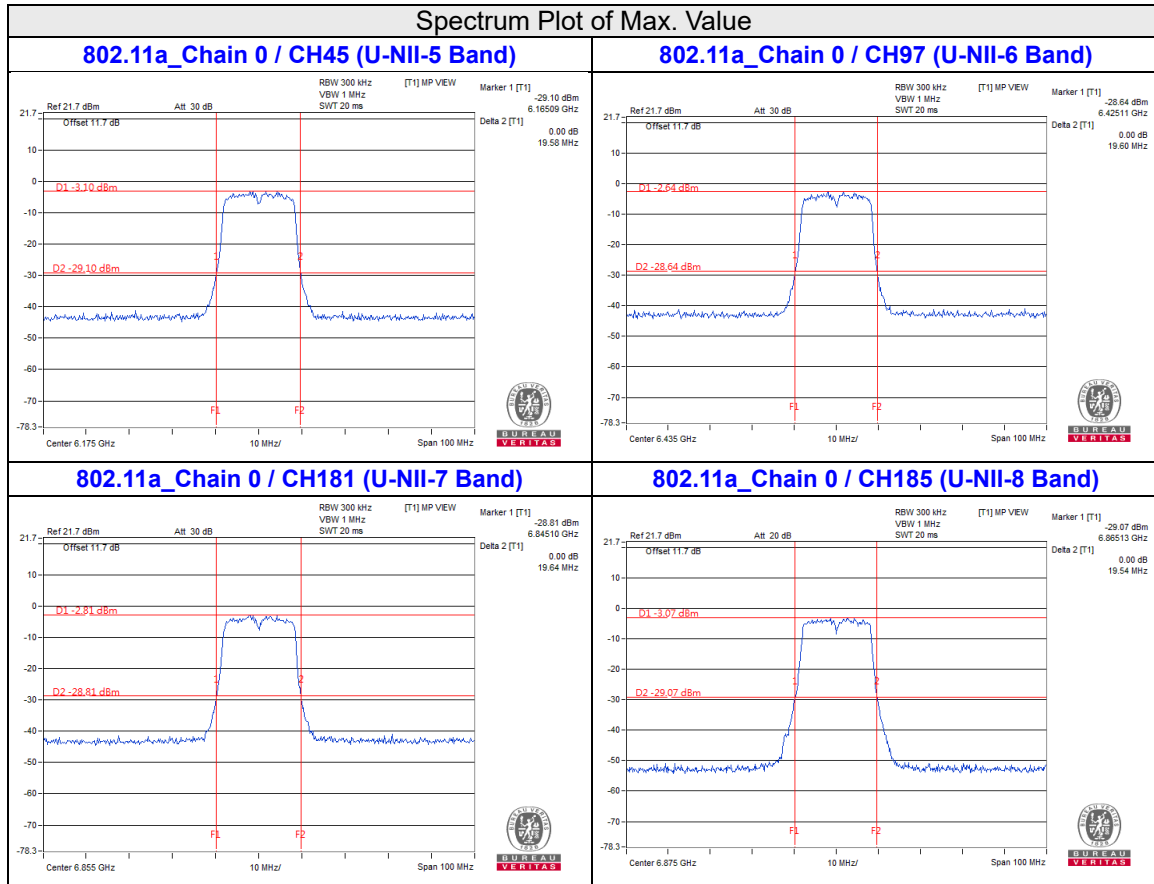



### Spectrum Plot of Max. Value

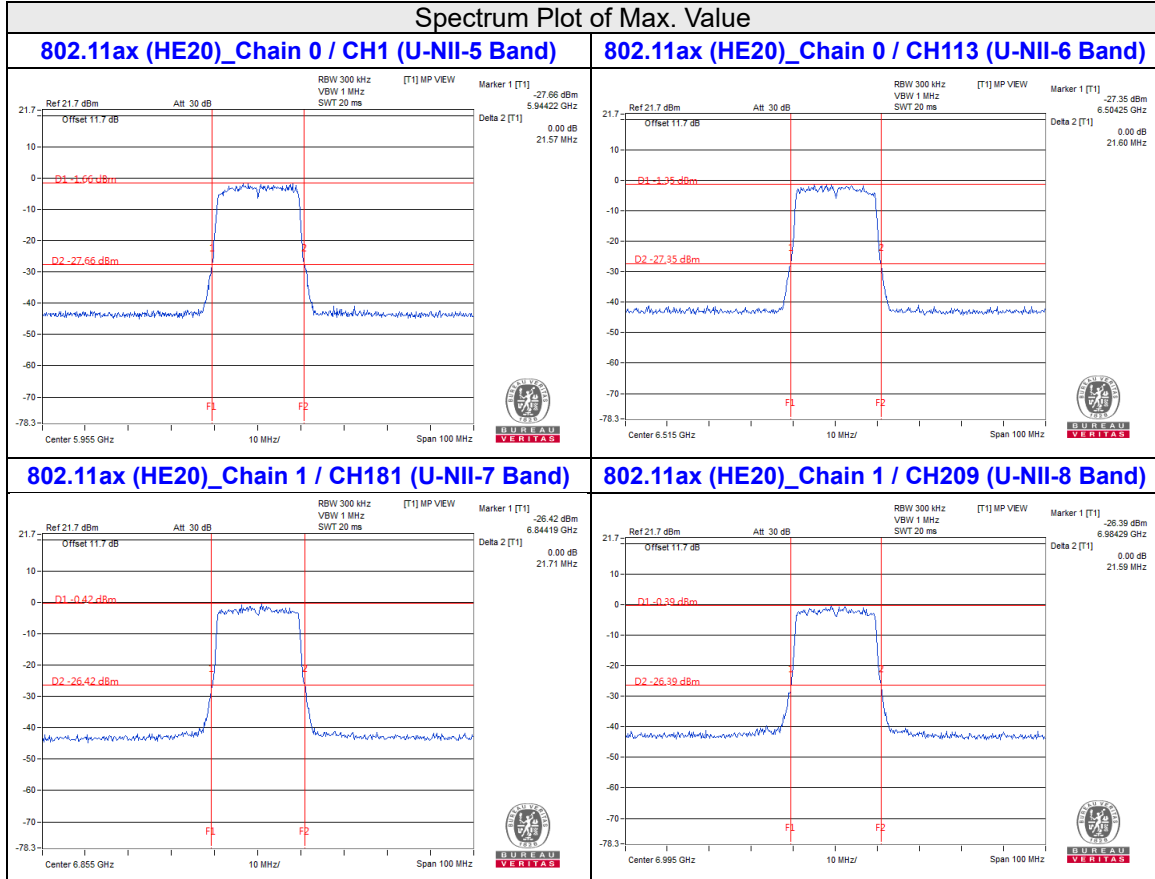

### Spectrum Plot of Max. Value

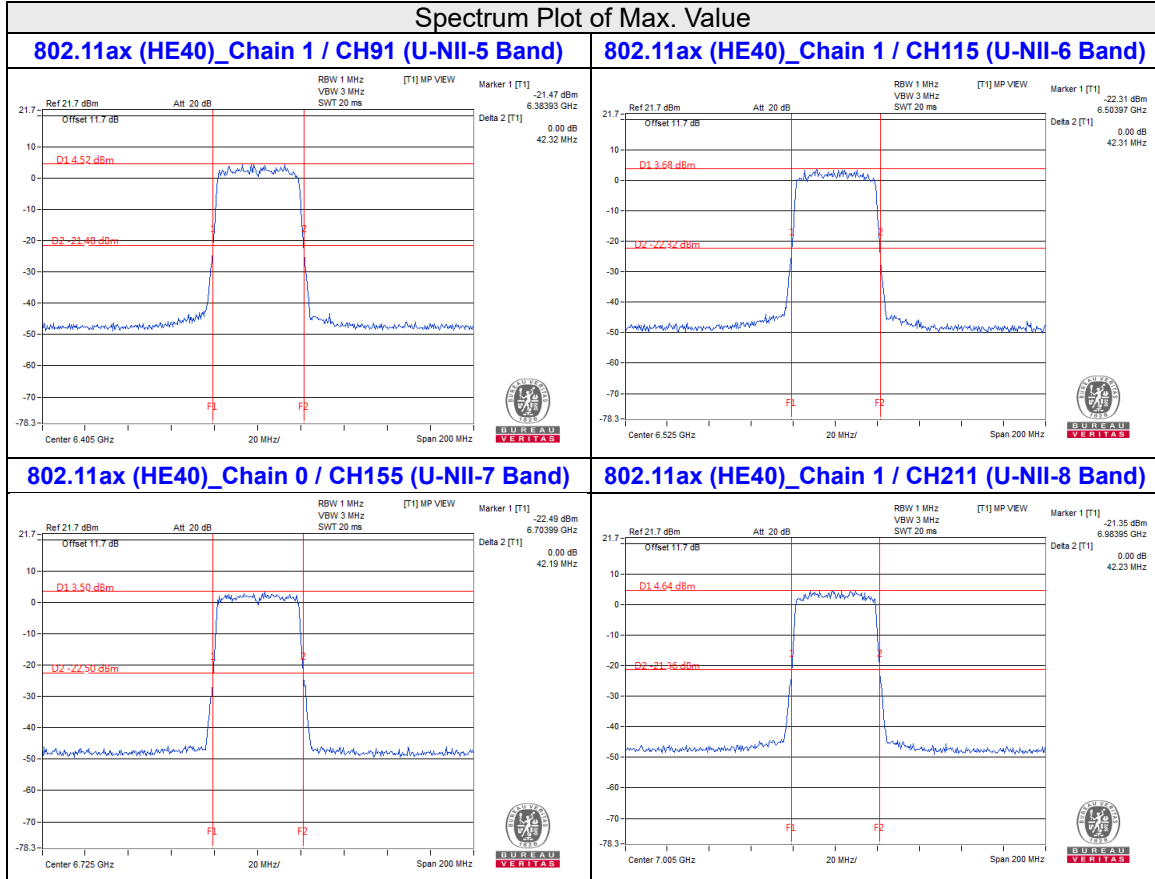

### Spectrum Plot of Max. Value

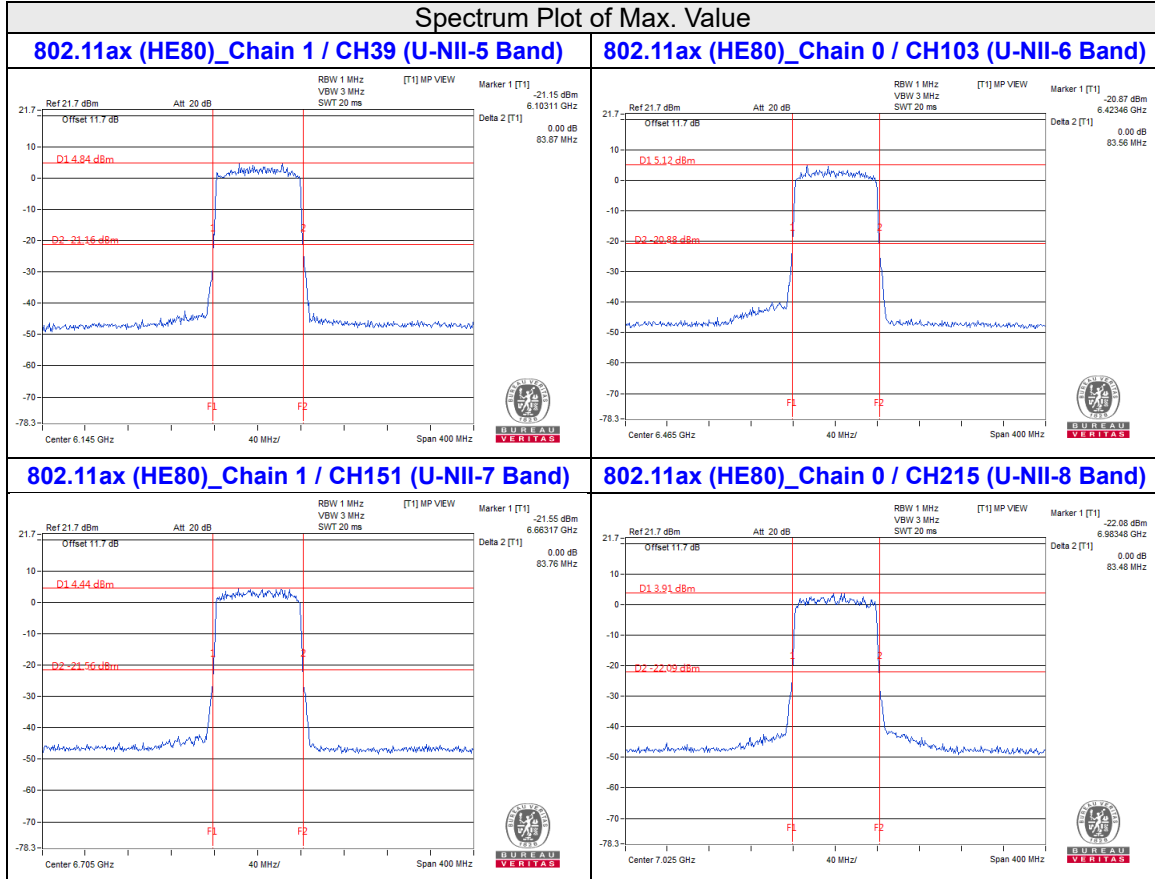

### Spectrum Plot of Max. Value

**802.11ax (HE160)\_Chain 0 / CH79 (U-NII-5 Band)**

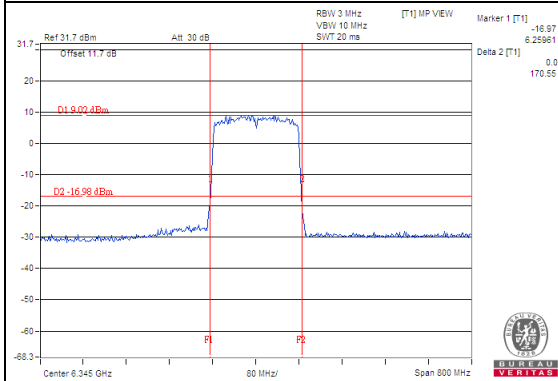

**802.11ax (HE160)\_Chain 0 / CH111 (U-NII-6 Band)**

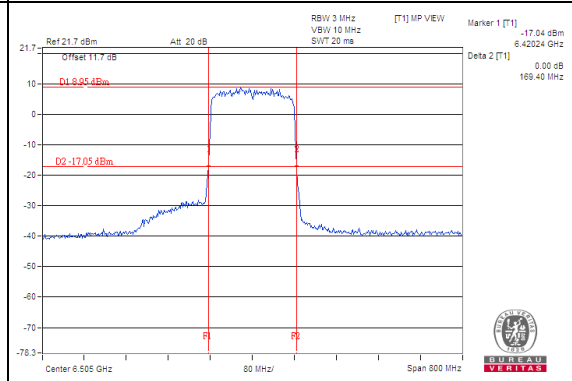

**802.11ax (HE160)\_Chain 0 / CH143 (U-NII-7 Band)**

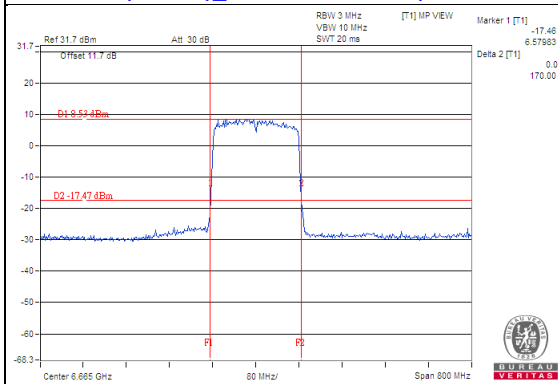

**802.11ax (HE160)\_Chain 1 / CH207 (U-NII-8 Band)**

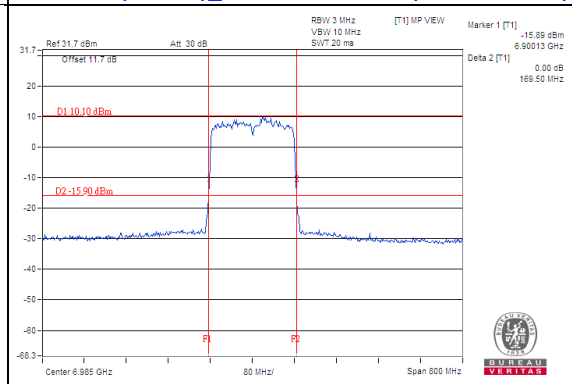

## 4.6 Peak Power Spectral Density Measurement

### 4.6.1 Limits of Peak Power Spectral Density Measurement

Operation Band	EUT Category	Limit
		Peak Power Density (EIRP)
U-NII-5 U-NII-6 U-NII-7 U-NII-8	Client Devices ( controlled of an indoor AP )	-1 dBm/MHz

### 4.6.2 Test Setup

For Conducted Method

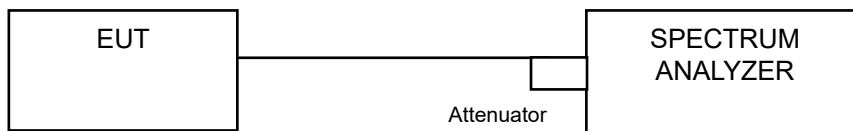

### 4.6.3 Test Instruments

Refer to section 4.1.2 to get information of above instrument.

### 4.6.4 Test Procedure

Using method SA-2

- a. Set span to encompass the entire emission bandwidth (EBW) of the signal.
- b. Set RBW = 1 MHz, Set VBW  $\geq$  3 MHz
- c. Sweep time = auto, trigger set to "free run".
- d. Detector = RMS
- e. Trace average at least 100 traces in power averaging mode.
- f. Record the max value and add  $10 \log (1/\text{duty cycle})$

### 4.6.5 EUT Operating Condition

Same as Item 4.3.6.

#### 4.6.6 Test Results

##### 802.11a

Chan.	Chan. Freq. (MHz)	PSD w/o Duty Factor (dBm/MHz)		Total PSD (dBm/MHz)	Directional Gain (dBi)	EIRP PSD (dBm/MHz)	EIRP PSD Limit (dBm/MHz)	Pass / Fail
		Chain 0	Chain 1					
1	5955	-9.16	-9.28	-6.21	5.01	-1.20	-1	Pass
45	6175	-8.96	-9.34	-6.14	5.01	-1.13	-1	Pass
93	6415	-9.67	-9.04	-6.33	5.01	-1.32	-1	Pass
97	6435	-8.83	-8.33	-5.56	4.51	-1.05	-1	Pass
105	6475	-9.02	-8.48	-5.73	4.51	-1.22	-1	Pass
113	6515	-8.72	-8.65	-5.68	4.51	-1.17	-1	Pass
117	6535	-8.69	-8.71	-5.69	4.51	-1.18	-1	Pass
149	6695	-9.27	-8.72	-5.98	4.51	-1.47	-1	Pass
181	6855	-9.17	-8.11	-5.60	4.51	-1.09	-1	Pass
185	6875	-9.36	-8.37	-5.83	4.01	-1.82	-1	Pass
209	6995	-9.24	-8.16	-5.66	4.01	-1.65	-1	Pass
233	7115	-6.87	-10.26	-5.23	4.01	-1.22	-1	Pass

Note: 1. Method a) of power density measurement of KDB 662911 is using for calculating total power density. Total power density is summing entire spectra across corresponding frequency bins on the various outputs by computer.

2. U-NII-5: Directional gain = 2dBi + 10log(2) = 5.01dBi
3. U-NII-6: Directional gain = 1.5dBi + 10log(2) = 4.51dBi
4. U-NII-7: Directional gain = 1.5dBi + 10log(2) = 4.51dBi
5. U-NII-8: Directional gain = 1dBi + 10log(2) = 4.01dBi

### 802.11ax (HE20)

Chan.	Chan. Freq. (MHz)	PSD w/o Duty Factor (dBm/MHz)		Total PSD (dBm/MHz)	Directional Gain (dBi)	EIRP PSD (dBm/MHz)	EIRP PSD Limit (dBm/MHz)	Pass / Fail
		Chain 0	Chain 1					
1	5955	-9.11	-9.10	-6.09	5.01	-1.08	-1	Pass
45	6175	-8.73	-9.43	-6.06	5.01	-1.05	-1	Pass
93	6415	-9.53	-9.02	-6.26	5.01	-1.25	-1	Pass
97	6435	-9.36	-8.40	-5.84	4.51	-1.33	-1	Pass
105	6475	-9.28	-8.50	-5.86	4.51	-1.35	-1	Pass
113	6515	-8.79	-8.98	-5.87	4.51	-1.36	-1	Pass
117	6535	-8.94	-8.87	-5.89	4.51	-1.38	-1	Pass
149	6695	-9.16	-8.52	-5.82	4.51	-1.31	-1	Pass
181	6855	-9.59	-8.21	-5.84	4.51	-1.33	-1	Pass
185	6875	-8.79	-7.95	-5.34	4.01	-1.33	-1	Pass
209	6995	-8.85	-7.50	-5.11	4.01	-1.10	-1	Pass
233	7115	-15.43	-15.37	-12.39	4.01	-8.38	-1	Pass

Note: 1. Method a) of power density measurement of KDB 662911 is using for calculating total power density. Total power density is summing entire spectra across corresponding frequency bins on the various outputs by computer.

2. U-NII-5: Directional gain = 2dBi + 10log(2) = 5.01dBi
3. U-NII-6: Directional gain = 1.5dBi + 10log(2) = 4.51dBi
4. U-NII-7: Directional gain = 1.5dBi + 10log(2) = 4.51dBi
5. U-NII-8: Directional gain = 1dBi + 10log(2) = 4.01dBi

### 802.11ax (HE40)

Chan.	Chan. Freq. (MHz)	PSD w/o Duty Factor (dBm/MHz)		Total PSD (dBm/MHz)	Directional Gain (dBi)	EIRP PSD (dBm/MHz)	EIRP PSD Limit (dBm/MHz)	Pass / Fail
		Chain 0	Chain 1					
3	5965	-9.16	-9.12	-6.13	5.01	-1.12	-1	Pass
43	6165	-9.10	-9.67	-6.37	5.01	-1.36	-1	Pass
91	6405	-9.55	-8.77	-6.13	5.01	-1.12	-1	Pass
99	6445	-9.27	-8.61	-5.92	4.51	-1.41	-1	Pass
107	6485	-8.98	-8.18	-5.55	4.51	-1.04	-1	Pass
115	6525	-8.84	-8.63	-5.72	4.51	-1.21	-1	Pass
123	6565	-8.95	-9.02	-5.97	4.51	-1.46	-1	Pass
155	6725	-9.42	-8.17	-5.74	4.51	-1.23	-1	Pass
179	6845	-9.49	-7.97	-5.65	4.51	-1.14	-1	Pass
187	6885	-8.12	-8.11	-5.10	4.01	-1.09	-1	Pass
211	7005	-8.50	-7.79	-5.12	4.01	-1.11	-1	Pass
227	7085	-7.41	-9.06	-5.15	4.01	-1.14	-1	Pass

Note: 1. Method a) of power density measurement of KDB 662911 is using for calculating total power density. Total power density is summing entire spectra across corresponding frequency bins on the various outputs by computer.

2. U-NII-5: Directional gain = 2dBi + 10log(2) = 5.01dBi
3. U-NII-6: Directional gain = 1.5dBi + 10log(2) = 4.51dBi
4. U-NII-7: Directional gain = 1.5dBi + 10log(2) = 4.51dBi
5. U-NII-8: Directional gain = 1dBi + 10log(2) = 4.01dBi

### 802.11ax (HE80)

Chan.	Chan. Freq. (MHz)	PSD w/o Duty Factor (dBm/MHz)		Total PSD (dBm/MHz)	Directional Gain (dBi)	EIRP PSD (dBm/MHz)	EIRP PSD Limit (dBm/MHz)	Pass / Fail
		Chain 0	Chain 1					
7	5985	-8.61	-9.73	-6.12	5.01	-1.11	-1	Pass
39	6145	-9.39	-8.84	-6.10	5.01	-1.09	-1	Pass
87	6385	-8.80	-10.09	-6.39	5.01	-1.38	-1	Pass
103	6465	-9.02	-8.41	-5.69	4.51	-1.18	-1	Pass
119	6545	-8.86	-8.91	-5.88	4.51	-1.37	-1	Pass
151	6705	-9.28	-8.54	-5.88	4.51	-1.37	-1	Pass
183	6865	-9.14	-8.48	-5.79	4.51	-1.28	-1	Pass
199	6945	-6.99	-9.86	-5.18	4.01	-1.17	-1	Pass
215	7025	-9.59	-7.28	-5.27	4.01	-1.26	-1	Pass

Note: 1. Method a) of power density measurement of KDB 662911 is using for calculating total power density. Total power density is summing entire spectra across corresponding frequency bins on the various outputs by computer.

2. U-NII-5: Directional gain = 2dBi + 10log(2) = 5.01dBi
3. U-NII-6: Directional gain = 1.5dBi + 10log(2) = 4.51dBi
4. U-NII-7: Directional gain = 1.5dBi + 10log(2) = 4.51dBi
5. U-NII-8: Directional gain = 1dBi + 10log(2) = 4.01dBi



### 802.11ax (HE160)

Chan.	Chan. Freq. (MHz)	PSD w/o Duty Factor (dBm/MHz)		Total PSD (dBm/MHz)	Directional Gain (dBi)	EIRP PSD (dBm/MHz)	EIRP PSD Limit (dBm/MHz)	Pass / Fail
		Chain 0	Chain 1					
15	6025	-9.59	-9.32	-6.44	5.01	-1.43	-1	Pass
47	6185	-9.12	-10.23	-6.63	5.01	-1.62	-1	Pass
79	6345	-8.85	-10.06	-6.40	5.01	-1.39	-1	Pass
111	6505	-8.60	-9.14	-5.85	4.51	-1.34	-1	Pass
143	6665	-8.49	-9.17	-5.81	4.51	-1.30	-1	Pass
175	6825	-9.44	-8.75	-6.07	4.51	-1.56	-1	Pass
207	6985	-8.96	-8.21	-5.56	4.01	-1.55	-1	Pass

Note: 1. Method a) of power density measurement of KDB 662911 is using for calculating total power density. Total power density is summing entire spectra across corresponding frequency bins on the various outputs by computer.

2. U-NII-5: Directional gain = 2dBi + 10log(2) = 5.01dBi
3. U-NII-6: Directional gain = 1.5dBi + 10log(2) = 4.51dBi
4. U-NII-7: Directional gain = 1.5dBi + 10log(2) = 4.51dBi
5. U-NII-8: Directional gain = 1dBi + 10log(2) = 4.01dBi

### 20MHz Preamble

#### 802.11ax (RU26)

Chan.	Chan. Freq. (MHz)	PSD w/o Duty Factor (dBm/MHz)		Total PSD (dBm/MHz)	Directional Gain (dBi)	EIRP PSD (dBm/MHz)	EIRP PSD Limit (dBm/MHz)	Pass / Fail
		Chain 0	Chain 1					
1	5955	-9.87	-9.07	-6.44	5.01	-1.43	-1	Pass
233	7115	-13.76	-13.71	-10.72	4.01	-6.71	-1	Pass

Note: 1. Method a) of power density measurement of KDB 662911 is using for calculating total power density. Total power density is summing entire spectra across corresponding frequency bins on the various outputs by computer.

2. U-NII-5: Directional gain = 2dBi + 10log(2) = 5.01dBi
3. U-NII-8: Directional gain = 1dBi + 10log(2) = 4.01dBi

#### 802.11ax (RU52)

Chan.	Chan. Freq. (MHz)	PSD w/o Duty Factor (dBm/MHz)		Total PSD (dBm/MHz)	Directional Gain (dBi)	EIRP PSD (dBm/MHz)	EIRP PSD Limit (dBm/MHz)	Pass / Fail
		Chain 0	Chain 1					
1	5955	-9.55	-8.90	-6.20	5.01	-1.19	-1	Pass
233	7115	-15.22	-15.12	-12.16	4.01	-8.15	-1	Pass

Note: 1. Method a) of power density measurement of KDB 662911 is using for calculating total power density. Total power density is summing entire spectra across corresponding frequency bins on the various outputs by computer.

2. U-NII-5: Directional gain = 2dBi + 10log(2) = 5.01dBi
3. U-NII-8: Directional gain = 1dBi + 10log(2) = 4.01dBi

### 802.11ax (RU106)

Chan.	Chan. Freq. (MHz)	PSD w/o Duty Factor (dBm/MHz)		Total PSD (dBm/MHz)	Directional Gain (dBi)	EIRP PSD (dBm/MHz)	EIRP PSD Limit (dBm/MHz)	Pass / Fail
		Chain 0	Chain 1					
1	5955	-10.20	-8.71	-6.38	5.01	-1.37	-1	Pass
233	7115	-16.66	-16.62	-13.63	4.01	-9.62	-1	Pass

Note: 1. Method a) of power density measurement of KDB 662911 is using for calculating total power density. Total power density is summing entire spectra across corresponding frequency bins on the various outputs by computer.

2. U-NII-5: Directional gain = 2dBi + 10log(2) = 5.01dBi

3. U-NII-8: Directional gain = 1dBi + 10log(2) = 4.01dBi

### 802.11ax (RU242)

Chan.	Chan. Freq. (MHz)	PSD w/o Duty Factor (dBm/MHz)		Total PSD (dBm/MHz)	Directional Gain (dBi)	EIRP PSD (dBm/MHz)	EIRP PSD Limit (dBm/MHz)	Pass / Fail
		Chain 0	Chain 1					
1	5955	-9.38	-9.43	-6.39	5.01	-1.38	-1	Pass
233	7115	-15.37	-15.28	-12.31	4.01	-8.30	-1	Pass

Note: 1. Method a) of power density measurement of KDB 662911 is using for calculating total power density. Total power density is summing entire spectra across corresponding frequency bins on the various outputs by computer.

2. U-NII-5: Directional gain = 2dBi + 10log(2) = 5.01dBi

3. U-NII-8: Directional gain = 1dBi + 10log(2) = 4.01dBi

### 40MHz Preamble

### 802.11ax (RU484)

Chan.	Chan. Freq. (MHz)	PSD w/o Duty Factor (dBm/MHz)		Total PSD (dBm/MHz)	Directional Gain (dBi)	EIRP PSD (dBm/MHz)	EIRP PSD Limit (dBm/MHz)	Pass / Fail
		Chain 0	Chain 1					
3	5965	-10.11	-8.96	-6.49	5.01	-1.48	-1	Pass
227	7085	-7.53	-8.98	-5.18	4.01	-1.17	-1	Pass

Note: 1. Method a) of power density measurement of KDB 662911 is using for calculating total power density. Total power density is summing entire spectra across corresponding frequency bins on the various outputs by computer.

2. U-NII-5: Directional gain = 2dBi + 10log(2) = 5.01dBi

3. U-NII-8: Directional gain = 1dBi + 10log(2) = 4.01dBi

### 80MHz Preamble

#### 802.11ax (RU996)

Chan.	Chan. Freq. (MHz)	PSD w/o Duty Factor (dBm/MHz)		Total PSD (dBm/MHz)	Directional Gain (dBi)	EIRP PSD (dBm/MHz)	EIRP PSD Limit (dBm/MHz)	Pass / Fail
		Chain 0	Chain 1					
7	5985	-9.21	-9.13	-6.16	5.01	-1.15	-1	Pass
215	7025	-9.22	-7.45	-5.23	4.01	-1.22	-1	Pass

Note: 1. Method a) of power density measurement of KDB 662911 is using for calculating total power density. Total power density is summing entire spectra across corresponding frequency bins on the various outputs by computer.

2. U-NII-5: Directional gain = 2dBi + 10log(2) = 5.01dBi

3. U-NII-8: Directional gain = 1dBi + 10log(2) = 4.01dBi

### 160MHz Preamble

#### 802.11ax (RU996\*2)

Chan.	Chan. Freq. (MHz)	PSD w/o Duty Factor (dBm/MHz)		Total PSD (dBm/MHz)	Directional Gain (dBi)	EIRP PSD (dBm/MHz)	EIRP PSD Limit (dBm/MHz)	Pass / Fail
		Chain 0	Chain 1					
15	6025	-9.59	-9.32	-6.44	5.01	-1.43	-1	Pass
207	6985	-8.96	-8.21	-5.56	4.01	-1.55	-1	Pass

Note: 1. Method a) of power density measurement of KDB 662911 is using for calculating total power density. Total power density is summing entire spectra across corresponding frequency bins on the various outputs by computer.

2. U-NII-5: Directional gain = 2dBi + 10log(2) = 5.01dBi

3. U-NII-8: Directional gain = 1dBi + 10log(2) = 4.01dBi

Spectrum Plot of Worst Value

802.11a\_Chain 0 / CH233

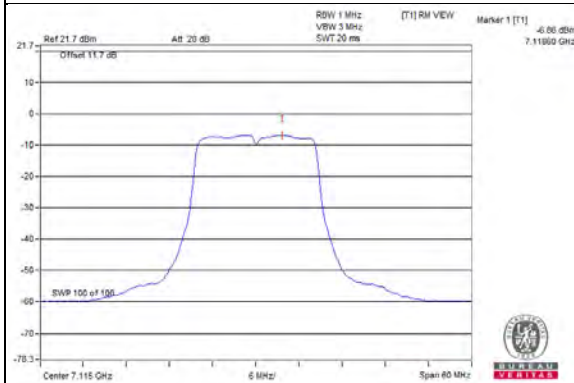

802.11ax (HE20)\_Chain 1 / CH209

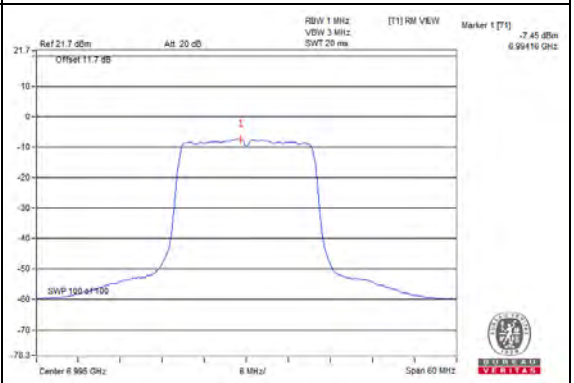

802.11ax (HE40)\_Chain 0 / CH227

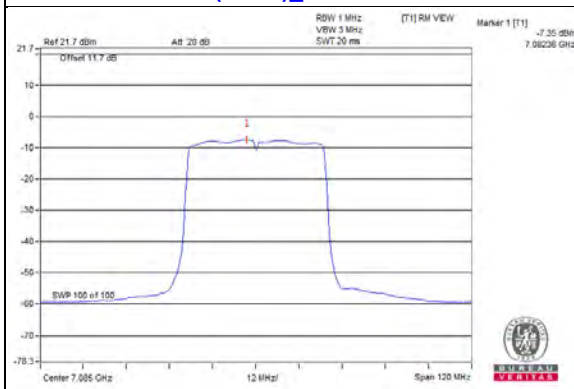

802.11ax (HE80)\_Chain 0 / CH199

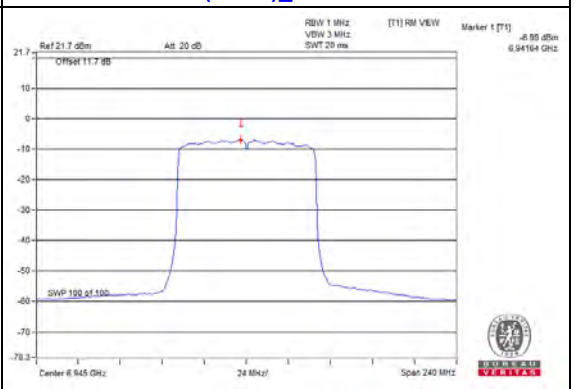

802.11ax (HE160)\_Chain 1 / CH207

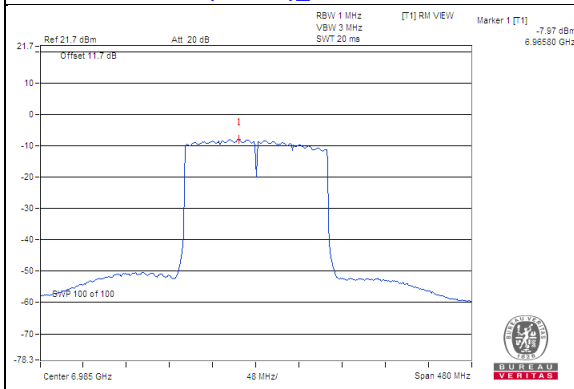

802.11ax (RU26)\_Chain 1 / CH1

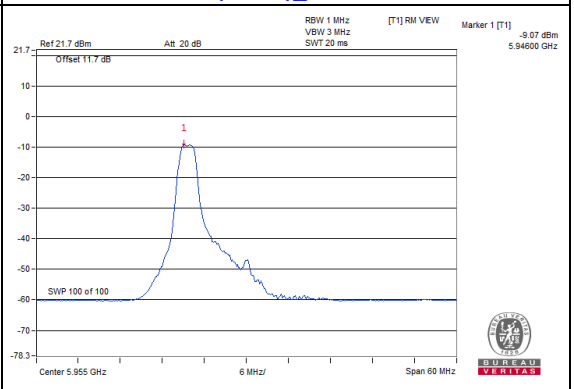

802.11ax (RU52)\_Chain 1 / CH1

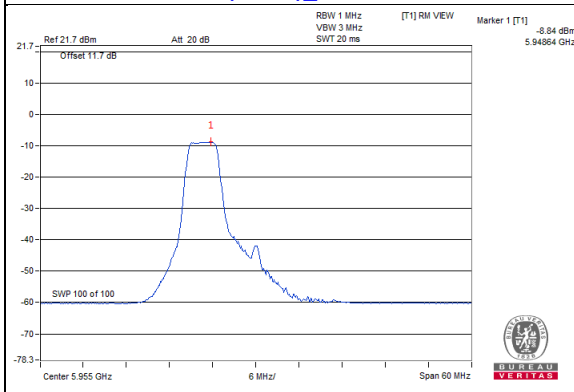

802.11ax (RU106)\_Chain 1 / CH1

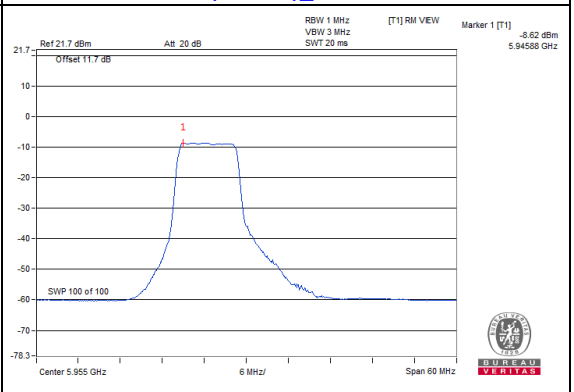

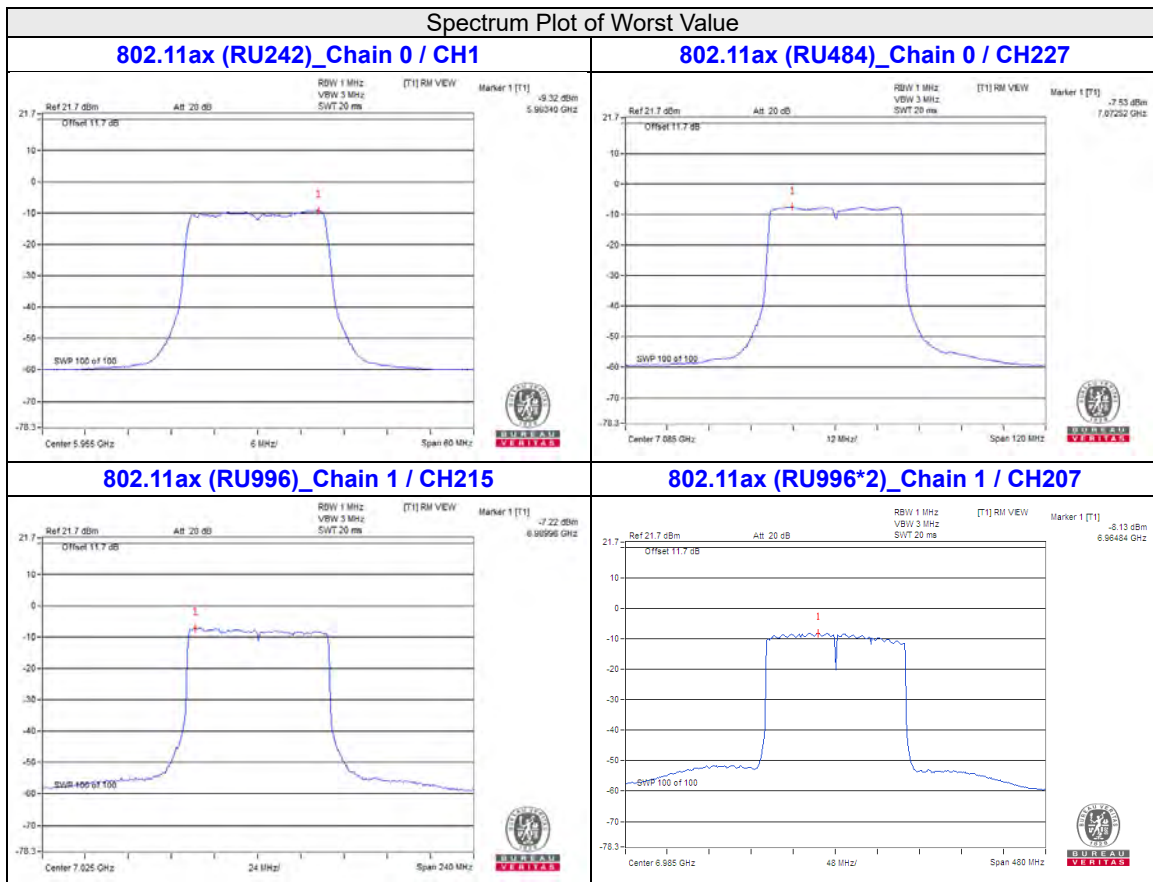

## 4.7 Contention Based Protocol Measurement

### 4.7.1 Limits of Contention Based Protocol Measurement

Unlicensed indoor low-power devices must detect co-channel radio frequency power that is at least -62 dBm (The threshold is referenced to a 0 dBi antenna gain.) or lower. Additionally, indoor low-power devices must detect co-channel energy with 90% or greater certainty.

### 4.7.2 Test Setup

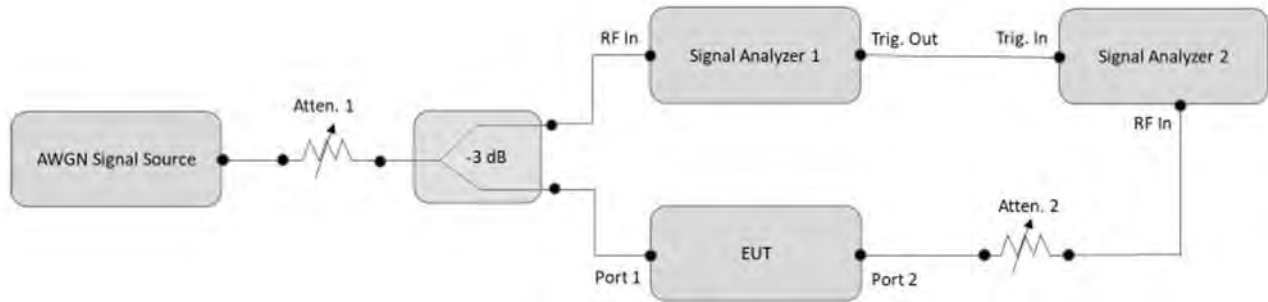

### EUT Information

Product	Brand	Model No.	Software/Firmware Version
Headset	VIVE	2QA4100	Android 10

### Companion Device Information

Product	Brand	Model No.	S/N	FCC ID
Router	NETGEAR	RAXE500	6JX11375A0FC4	PY320300508

### 4.7.3 Test Instruments

DESCRIPTION & MANUFACTURER	MODEL NO.	SERIAL NO.	CALIBRATED DATE	CALIBRATED UNTIL
Spectrum Analyzer R&S	FSW8	101497	Nov. 10, 2020	Nov. 09, 2021
Spectrum Analyzer R&S	FSV40	101516	Mar. 08, 2021	Mar. 07, 2022
MXG X-Series RF Vector Signal Generator Agilent	N5182B	MY59100182	Apr. 22, 2021	Apr. 21, 2022
N5182BU KEYSIGHT	N5182BX07	MY59360203	Dec. 10, 2020	Dec. 09, 2021
Power Splitter/combiner Mini-Circuits	ZFRSC-123-S+	F698501347_01	Jan. 27, 2021	Jan. 26, 2022

- NOTE:**
1. The test was performed in Femtocell room.
  2. The calibration interval of the above test instruments is 12 months and the calibrations are traceable to NML/ROC and NIST/USA.

#### 4.7.4 Test Procedure

- a. Set the signal analyzer center frequency to the nominal EUT channel center frequency. The span range of the signal analyzer shall be between two times and five times the OBW of the EUT. Connect the output port of the EUT to the signal analyzer 2. Ensure that the attenuator 2 provides enough attenuation to not overload the signal analyzer 2 receiver.
- b. Monitoring the signal analyzer 2, verify the EUT is operating and transmitting with the parameters (set as following section 4.7.5 EUT operating condition).
- c. Determine number of times detection threshold test as following table,

If	Number of Tests	Placement of Incumbent Transmission
$BW_{EUT} \leq BW_{Inc}$	Once	Same as EUT transmission
$BW_{Inc} < BW_{EUT} \leq 2x BW_{Inc}$	Once	Contained within $BW_{EUT}$
$2x BW_{Inc} < BW_{EUT} \leq 4x BW_{Inc}$	Twice. (Incumbent transmission is contained within $BW_{EUT}$ )	Closely to the lower edge and upper edge of the EUT Channel
$BW_{EUT} > 4x BW_{Inc}$	Three times	Closely to the lower edge ,in the middle and upper edge of the EUT Channel

- d. Using an AWGN signal source, generate (but do not transmit, i.e., RF OFF) a 10 MHz-wide AWGN signal. Use step c table to determine the center frequency of the 10 MHz AWGN signal relative to the EUT's channel bandwidth and center frequency.
- e. Set the AWGN signal power to an extremely low level (more than 20 dB below the -62 dBm threshold). Connect the AWGN signal source, via a 3-dB splitter, to the signal analyzer 1 and the EUT.
- f. Transmit the AWGN signal (RF ON) and verify its characteristics on the signal analyzer 1.
- g. Monitor the signal analyzer 2 to verify if the AWGN signal has been detected and the EUT has ceased transmission. If the EUT continues to transmit, then incrementally increase the AWGN signal power level until the EUT stops transmitting.
- h. (Including all losses in the RF paths) Determine and record the AWGN signal power level (at the EUT's antenna port) at which the EUT ceased transmission. Repeat the procedure at least 10 times to verify the EUT can detect an AWGN signal with 90% (or better) level of certainty.
- i. Refer to step c table to determine number of times the detection threshold testing needs to be repeated. If testing is required more than once, then go back to step d, choose a different center frequency for the AWGN signal and repeat the process.

#### 4.7.5 EUT Operating Condition

Set the EUT to transmit with a constant duty cycle and relative operating parameters which including power level, operating frequency, modulation and bandwidth.

### 4.7.6 Test Results

#### For U-NII-5 band

Contention Based Protocol Measurement									
Measurement Mode :		Conducted measurement		The Incumbent Signal(AWGN) Level(dBm) :			-62	at the antenna connector	
Device Type :		Indoor Client		Antenna Gain(dBi) :			0		
Operation Mode	Channel Bandwidth (MHz)	Channel Number	Channel Frequency (MHz)	AWGN Signal Frequency (MHz)	Number of Times	Number of Detected	Detection Rate	Minimum Limit	Pass/Fail
802.11ax	20	37	6135	6135	10	10	100%	90%	Pass
	160	47	6185	6110	10	10	100%	90%	Pass
				6185	10	10	100%	90%	Pass
				6260	10	10	100%	90%	Pass
Result		Complied							

Lowest Interference (AWGN) Level Check							
Operation Band	Operation Mode	Channel Bandwidth (MHz)	Channel Number	Channel Frequency (MHz)	AWGN Signal Frequency (MHz)	Threshold Level (dBm)	EUT Status
U-NII 5	802.11ax	20	37	6135	6135	-66	Start transmitting
		160	47	6185	6110	-63	Start transmitting
					6185	-63	Start transmitting
					6260	-62	Start transmitting

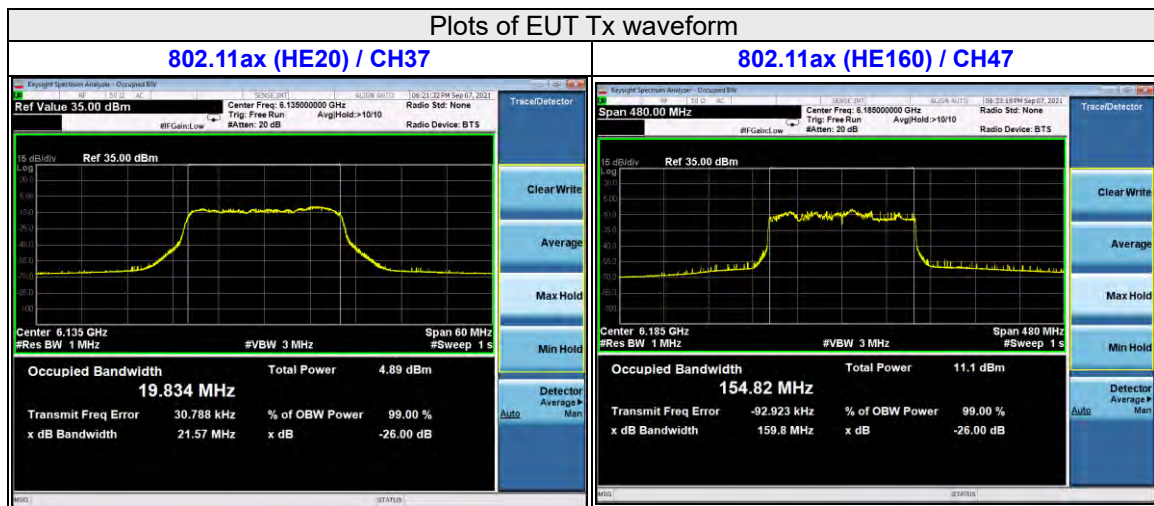



Plots of Incumbent signal(AWGN) Level

802.11ax (HE20) / CH37

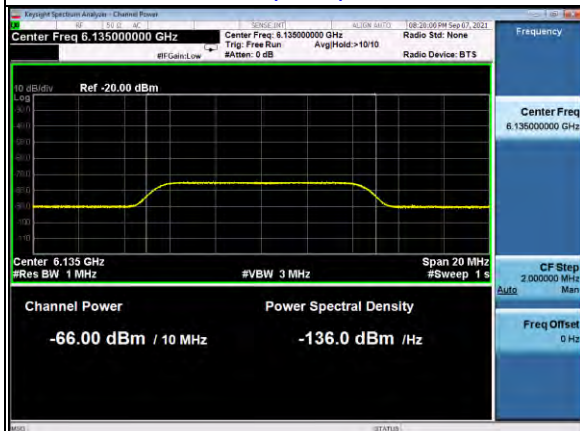

802.11ax (HE160) / CH47 (High Edge)



802.11ax (HE160) / CH47 (Middle)



802.11ax (HE160) / CH47 (Low Edge)

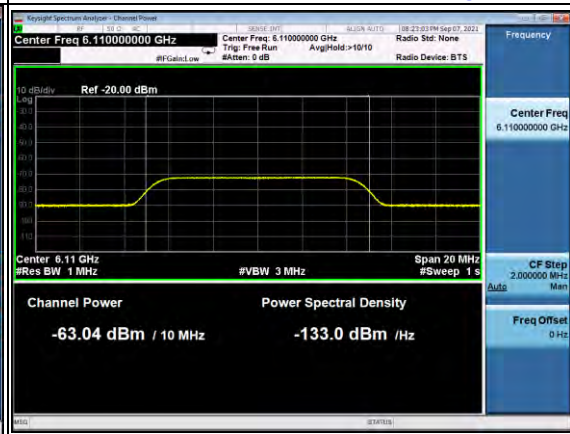

Plots of EUT ceased transmission in the time domain

802.11ax (HE20) / CH37

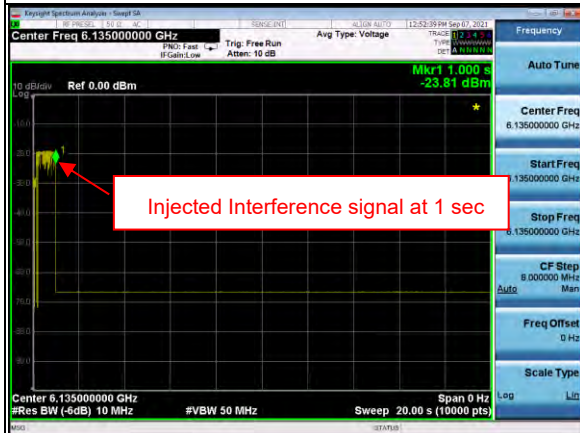

802.11ax (HE160) / CH47 (High Edge)

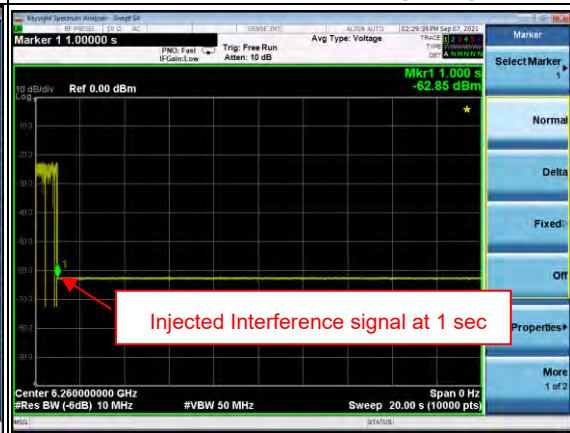

802.11ax (HE160) / CH47 (Middle)

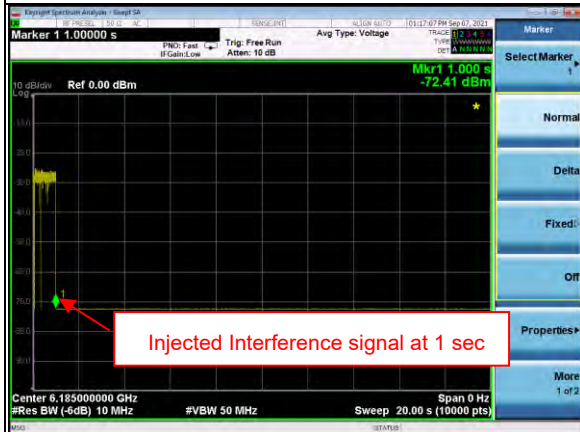

802.11ax (HE160) / CH47 (Low Edge)

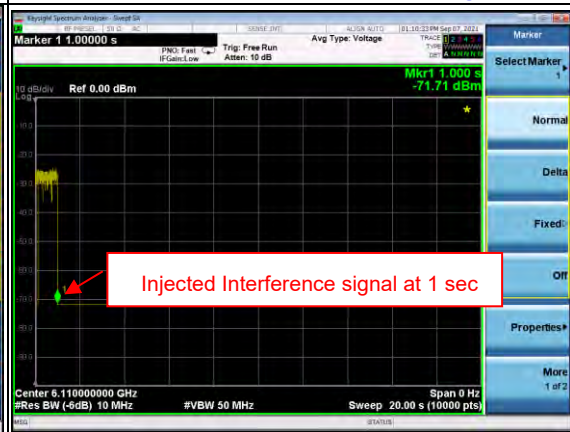

**For U-NII-6 band**

Contention Based Protocol Measurement									
Measurement Mode :		Conducted measurement		The Incumbent Signal(AWGN) Level(dBm) :			-62	at the antenna connector	
Device Type :		Indoor Client		Antenna Gain(dBi) :			0		
Operation Mode	Channel Bandwidth (MHz)	Channel Number	Channel Frequency (MHz)	AWGN Signal Frequency (MHz)	Number of Times	Number of Detected	Detection Rate	Minimum Limit	Pass/Fail
802.11ax	20	101	6455	6455	10	10	100%	90%	Pass
	160	111	6505	6430	10	10	100%	90%	Pass
				6505	10	10	100%	90%	Pass
				6580	10	10	100%	90%	Pass
<b>Result</b>		Complied							

Lowest Interference (AWGN) Level Check							
Operation Band	Operation Mode	Channel Bandwidth (MHz)	Channel Number	Channel Frequency (MHz)	AWGN Signal Frequency (MHz)	Threshold Level (dBm)	EUT Status
U-NII 6	802.11ax	20	101	6455	6455	-66	Start transmitting
		160	111	6505	6430	-64	Start transmitting
					6505	-64	Start transmitting
					6580	-63	Start transmitting

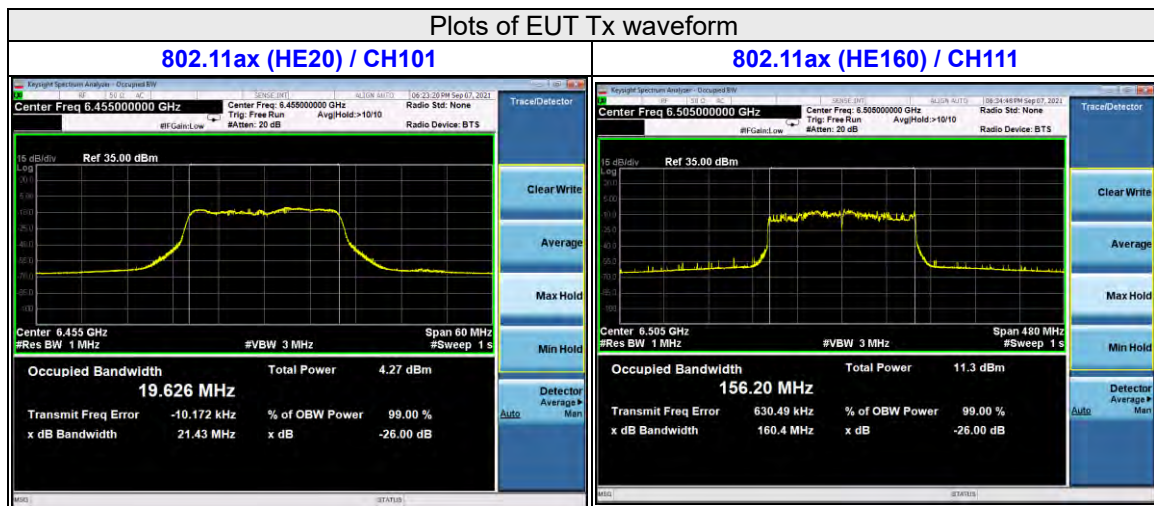

Plots of Incumbent signal(AWGN) Level

802.11ax (HE20) / CH101



802.11ax (HE160) / CH111 (High Edge)

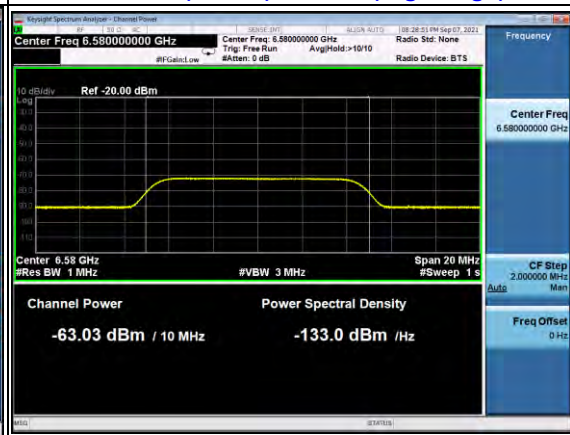

802.11ax (HE160) / CH111 (Middle)

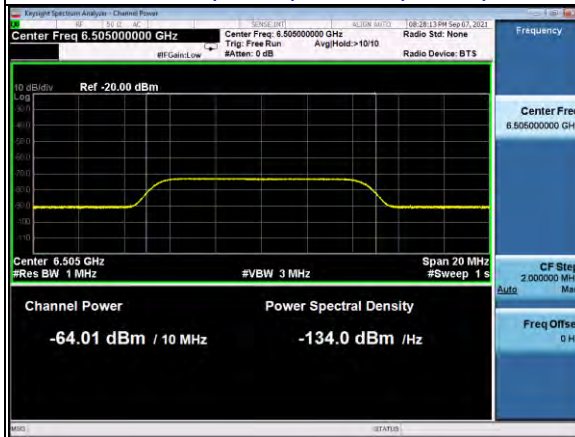

802.11ax (HE160) / CH111 (Low Edge)

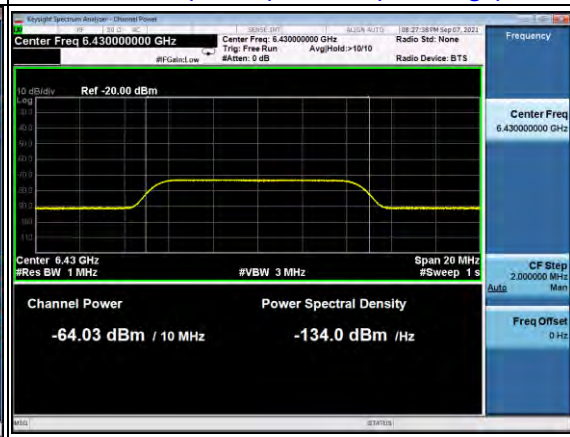

Plots of EUT ceased transmission in the time domain

802.11ax (HE20) / CH101

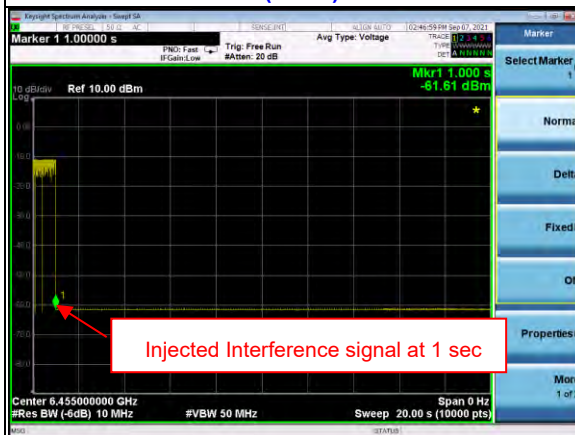

802.11ax (HE160) / CH111 (High Edge)

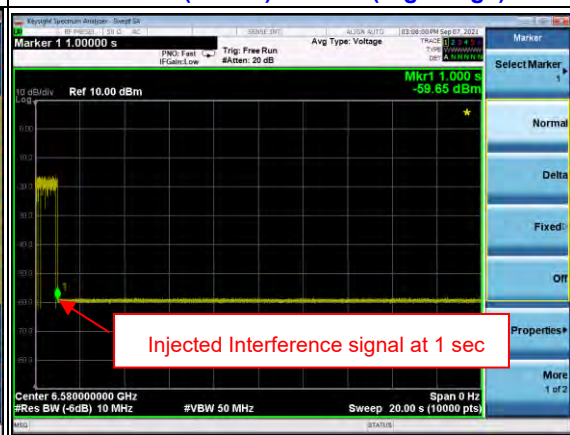

802.11ax (HE160) / CH111 (Middle)

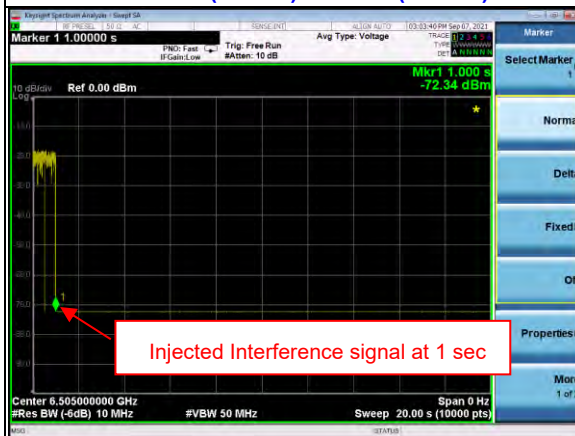

802.11ax (HE160) / CH111 (Low Edge)

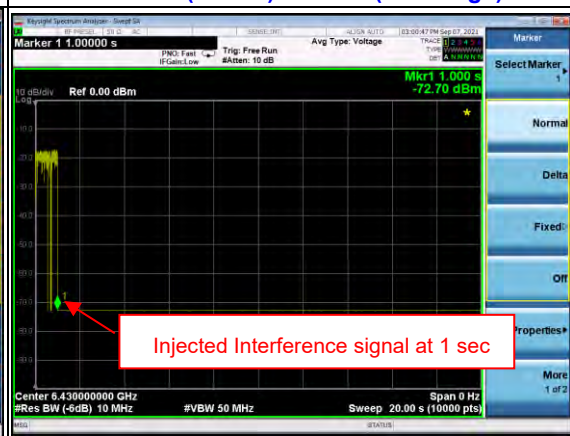

**For U-NII-7 band**

Contention Based Protocol Measurement										
Measurement Mode :		Conducted measurement		The Incumbent Signal(AWGN) Level(dBm) :			-62		at the antenna connector	
Device Type :		Indoor Client		Antenna Gain(dBI) :			0			
Operation Mode	Channel Bandwidth (MHz)	Channel Number	Channel Frequency (MHz)	AWGN Signal Frequency (MHz)	Number of Times	Number of Detected	Detection Rate	Minimum Limit	Pass/Fail	
802.11ax	20	149	6695	6695	10	10	100%	90%	Pass	
	160	143	6665	6590	10	10	100%	90%	Pass	
				6665	10	10	100%	90%	Pass	
				6740	10	10	100%	90%	Pass	
Result		Complied								

Lowest Interference (AWGN) Level Check							
Operation Band	Operation Mode	Channel Bandwidth (MHz)	Channel Number	Channel Frequency (MHz)	AWGN Signal Frequency (MHz)	Threshold Level (dBm)	EUT Status
U-NII 7	802.11ax	20	149	6695	6695	-66	Start transmitting
		160	143	6665	6590	-64	Start transmitting
					6665	-64	Start transmitting
					6740	-62	Start transmitting

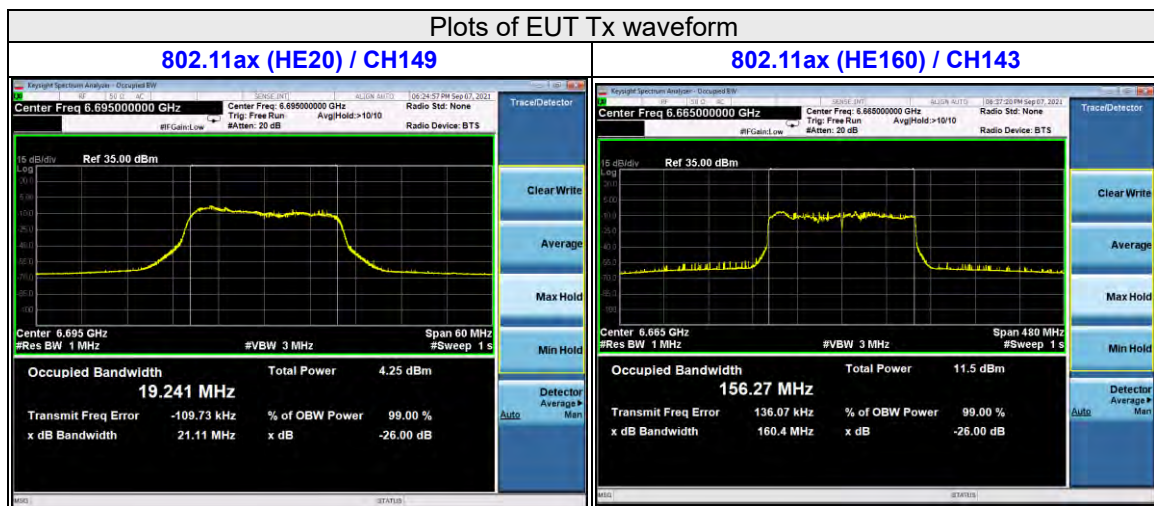

Plots of Incumbent signal(AWGN) Level

802.11ax (HE20) / CH149

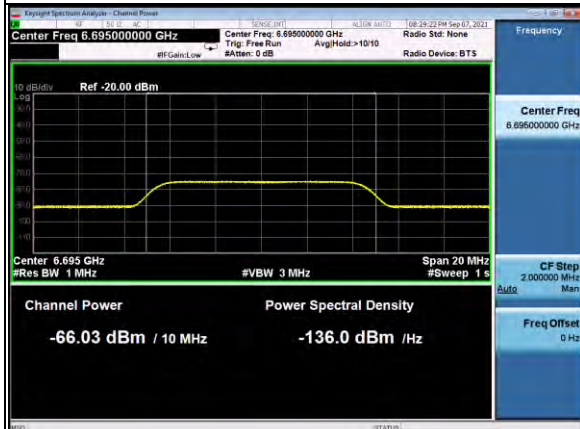

802.11ax (HE160) / CH143 (High Edge)

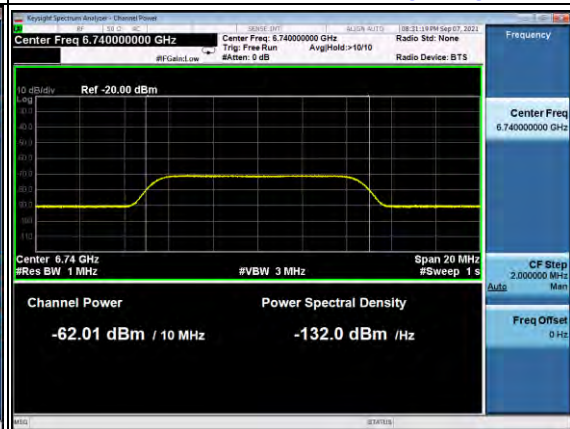

802.11ax (HE160) / CH143 (Middle)



802.11ax (HE160) / CH143 (Low Edge)



Plots of EUT ceased transmission in the time domain

802.11ax (HE20) / CH149

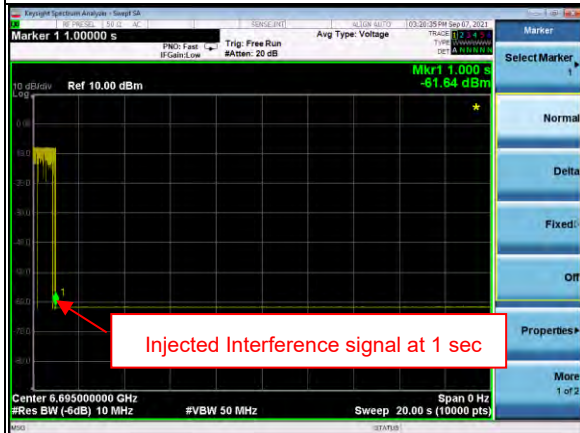

802.11ax (HE160) / CH143 (High Edge)

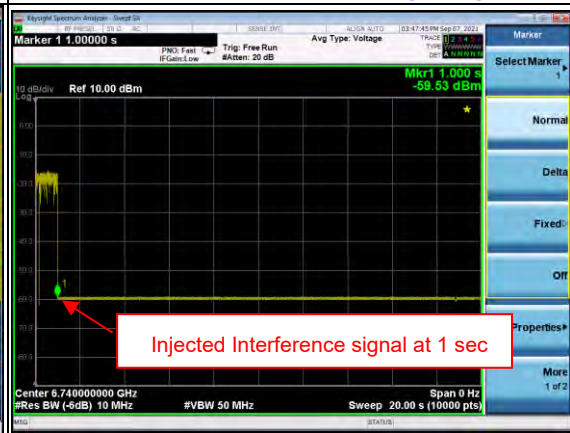

802.11ax (HE160) / CH143 (Middle)

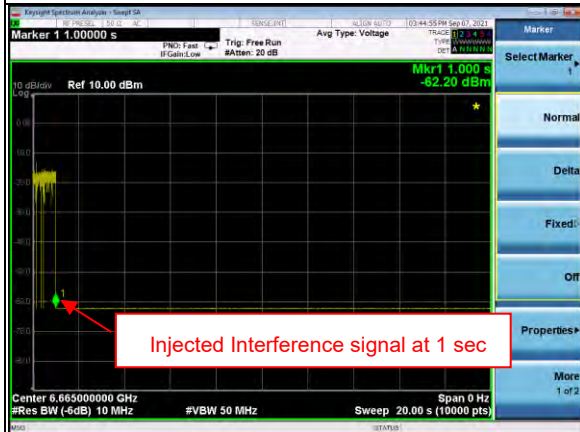

802.11ax (HE160) / CH143 (Low Edge)

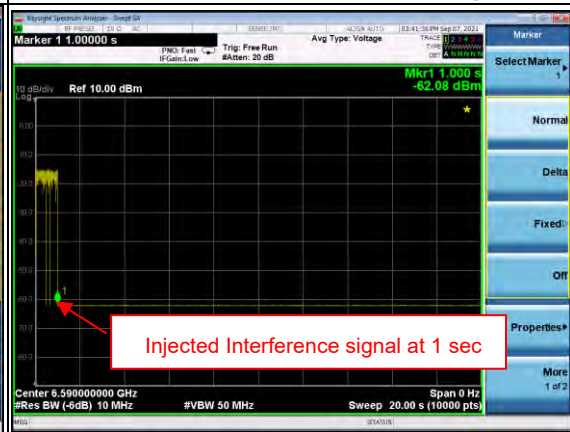



**For U-NII-8 band**

Contention Based Protocol Measurement									
Measurement Mode :		Conducted measurement		The Incumbent Signal(AWGN) Level(dBm) :			-62	at the antenna connector	
Device Type :		Indoor Client		Antenna Gain(dBi) :			0		
Operation Mode	Channel Bandwidth (MHz)	Channel Number	Channel Frequency (MHz)	AWGN Signal Frequency (MHz)	Number of Times	Number of Detected	Detection Rate	Minimum Limit	Pass/Fail
802.11ax	20	213	7015	7015	10	10	100%	90%	Pass
				6910	10	10	100%	90%	Pass
	160	207	6985	6985	10	10	100%	90%	Pass
				7060	10	10	100%	90%	Pass
<b>Result</b>		Complied							

Lowest Interference (AWGN) Level Check							
Operation Band	Operation Mode	Channel Bandwidth (MHz)	Channel Number	Channel Frequency (MHz)	AWGN Signal Frequency (MHz)	Threshold Level (dBm)	EUT Status
U-NII 8	802.11ax	20	213	7015	7015	-62	Start transmitting
					6910	-63	Start transmitting
		160	207	6985	6985	-63	Start transmitting
					7060	-62	Start transmitting

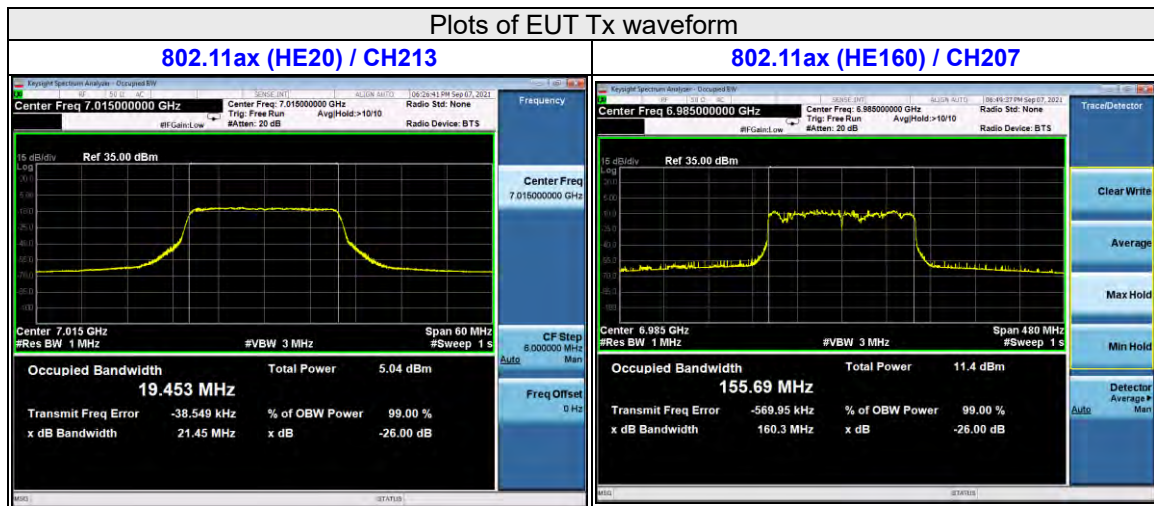

Plots of Incumbent signal(AWGN) Level

802.11ax (HE20) / CH213

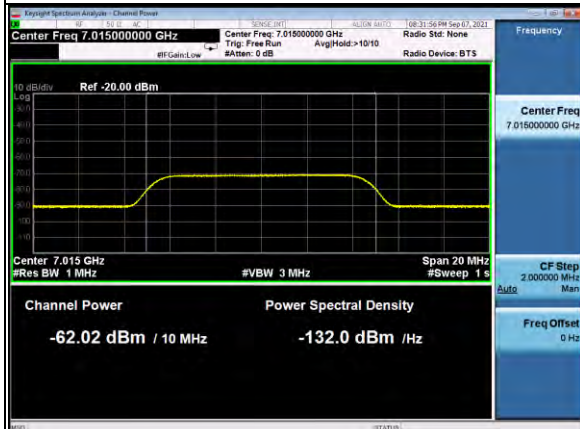

802.11ax (HE160) / CH207 (High Edge)



802.11ax (HE160) / CH207 (Middle)



802.11ax (HE160) / CH207 (Low Edge)



Plots of EUT ceased transmission in the time domain

802.11ax (HE20) / CH213

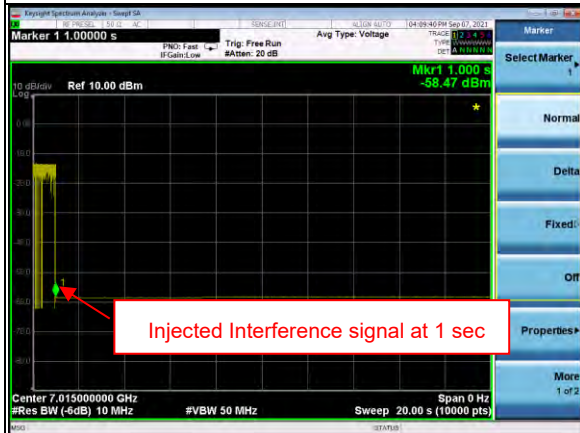

Injected Interference signal at 1 sec

802.11ax (HE160) / CH207 (High Edge)

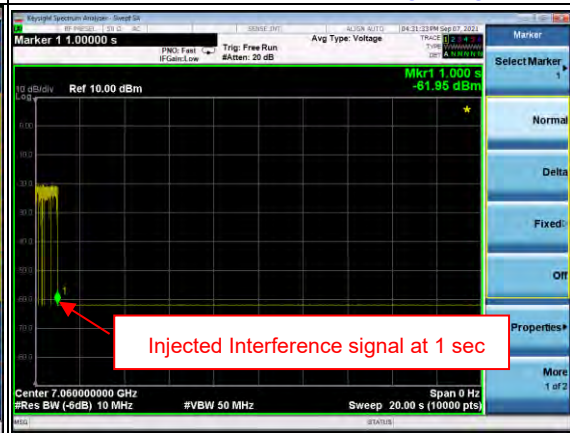

Injected Interference signal at 1 sec

802.11ax (HE160) / CH207 (Middle)

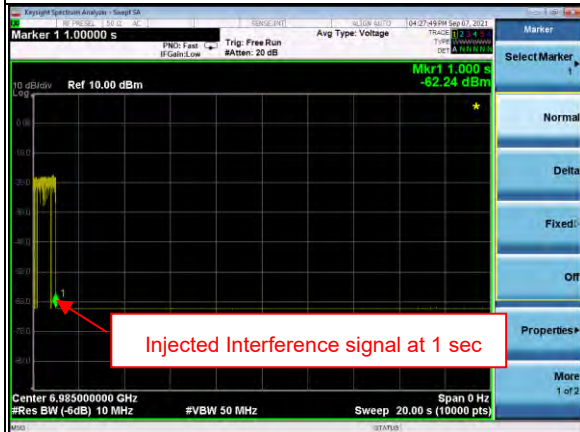

Injected Interference signal at 1 sec

802.11ax (HE160) / CH207 (Low Edge)

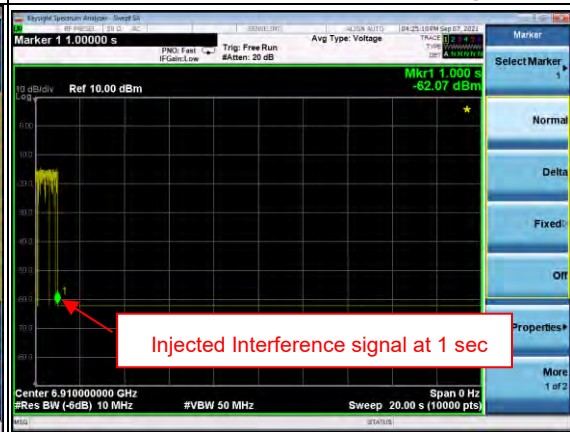

Injected Interference signal at 1 sec

## 4.8 Frequency Stability Measurement

### 4.8.1 Limits of Frequency Stability Measurement

The frequency of the carrier signal shall be maintained within band of operation

### 4.8.2 Test Setup

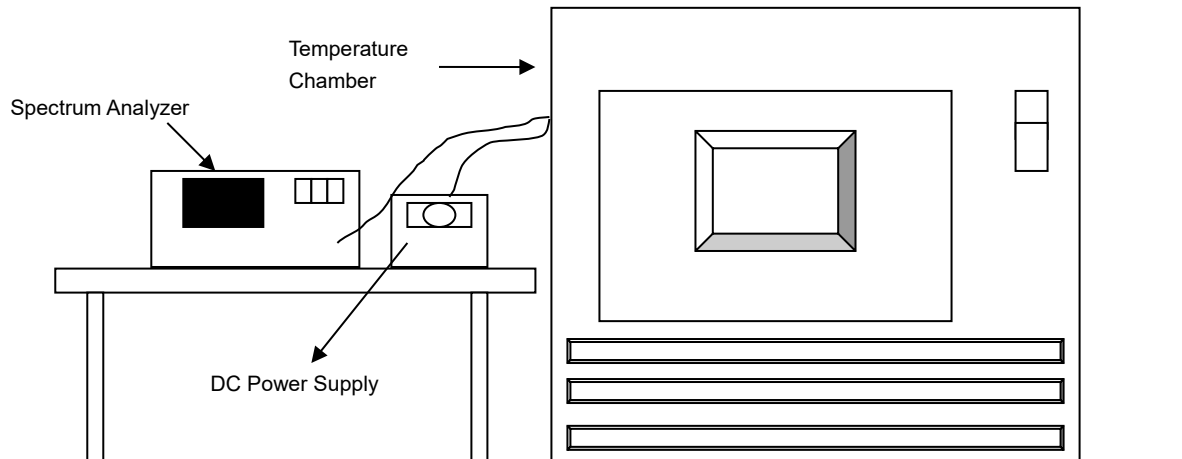

### 4.8.3 Test Instruments

Refer to section 4.1.2 to get information of above instrument.

### 4.8.4 Test Procedure

- The EUT was placed inside the environmental test chamber and powered by nominal DC voltage.
- Turn the EUT on and couple its output to a spectrum analyzer.
- Turn the EUT off and set the chamber to the highest temperature specified.
- Allow sufficient time (approximately 30 min) for the temperature of the chamber to stabilize, turn the EUT on and measure the operating frequency after 2, 5, and 10 Minutes.
- Repeat step (d) with the temperature chamber set to the next desired temperature until measurements down to the lowest specified temperature have been completed..
- The test chamber was allowed to stabilize at +20 degree C for a minimum of 30 Minutes. The supply voltage was then adjusted on the EUT from 85% to 115% and the frequency record.

### 4.8.5 EUT Operating Condition

Set the EUT transmit at un-modulation mode to test frequency stability.

## 4.8.6 Test Results

Frequency Stability Versus Temp.									
Operating Frequency: 5955MHz									
TEMP. (°C)	Power Supply (Vdc)	0 Minute		2 Minute		5 Minute		10 Minute	
		Measured Frequency (MHz)	Pass/Fail	Measured Frequency (MHz)	Pass/Fail	Measured Frequency (MHz)	Pass/Fail	Measured Frequency (MHz)	Pass/Fail
55	12	5955.0153	PASS	5955.0139	PASS	5955.0148	PASS	5955.0138	PASS
50	12	5954.992	PASS	5954.9947	PASS	5954.995	PASS	5954.9922	PASS
40	12	5955.019	PASS	5955.0221	PASS	5955.0181	PASS	5955.0211	PASS
30	12	5954.9722	PASS	5954.973	PASS	5954.9741	PASS	5954.9749	PASS
20	12	5954.9723	PASS	5954.973	PASS	5954.977	PASS	5954.9748	PASS
10	12	5955.0087	PASS	5955.0121	PASS	5955.0125	PASS	5955.0141	PASS
0	12	5955.022	PASS	5955.024	PASS	5955.0199	PASS	5955.0216	PASS
-10	12	5954.9784	PASS	5954.9793	PASS	5954.9781	PASS	5954.9801	PASS

Frequency Stability Versus Voltage									
Operating Frequency: 5955MHz									
TEMP. (°C)	Power Supply (Vdc)	0 Minute		2 Minute		5 Minute		10 Minute	
		Measured Frequency (MHz)	Pass/Fail	Measured Frequency (MHz)	Pass/Fail	Measured Frequency (MHz)	Pass/Fail	Measured Frequency (MHz)	Pass/Fail
20	13.8	5954.9713	PASS	5954.9732	PASS	5954.9768	PASS	5954.9757	PASS
	12	5954.9723	PASS	5954.973	PASS	5954.977	PASS	5954.9748	PASS
	10.2	5954.9724	PASS	5954.973	PASS	5954.9771	PASS	5954.9742	PASS

## 4.9 Operational Restrictions for 6 GHz U-NII Devices

### 4.9.1 Limits of Operational Restrictions for 6 GHz U-NII Devices

In the 5.925-7.125 GHz band, client devices, except fixed client devices, must operate under the control of a standard power access point, indoor access point or subordinate devices; Subordinate devices must operate under the control of an indoor access point.

### 4.9.2 Test Setup

N/A

### 4.9.3 Test Instruments

N/A

### 4.9.4 Test Procedure

N/A.

### 4.9.5 Test Results

Device is an indoor client device under the control of a low power indoor access point. Please refer to the declaration letter exhibit supplied within this application.

## 5 Pictures of Test Arrangements

Please refer to the attached file (Test Setup Photo).

## Annex A - Band-Edge Measurement

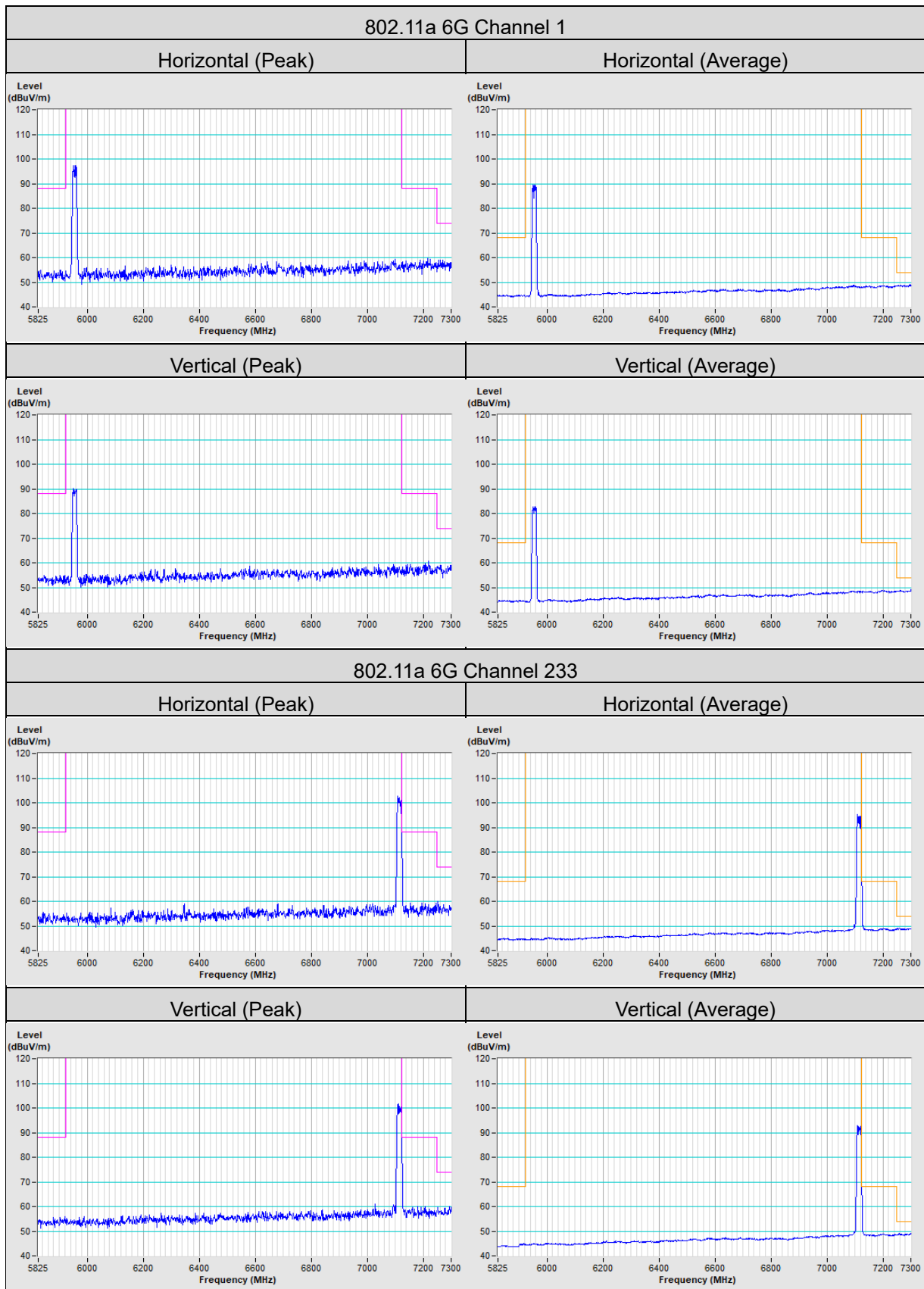



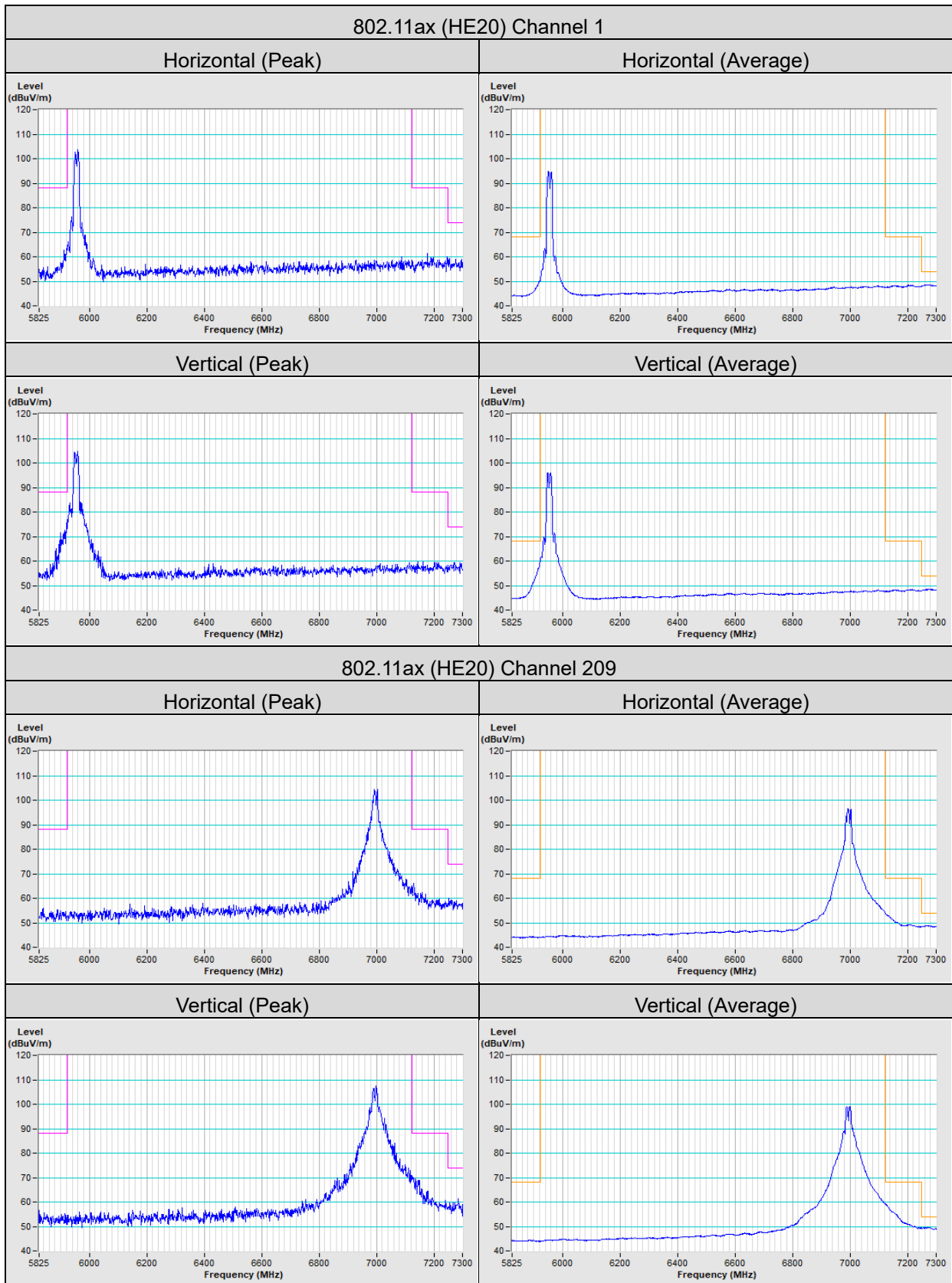

### 802.11ax (HE20) Channel 229

Horizontal (Peak)

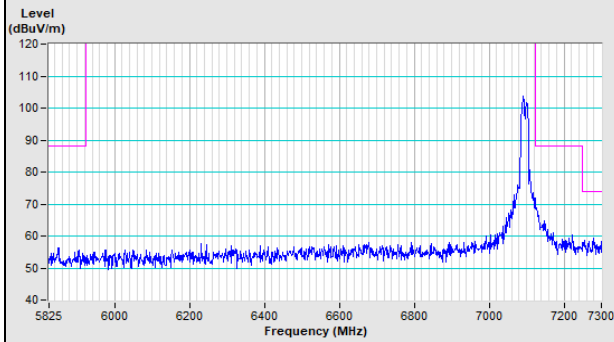

Horizontal (Average)

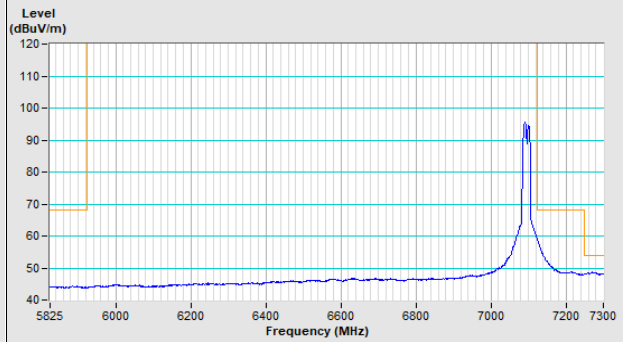

Vertical (Peak)

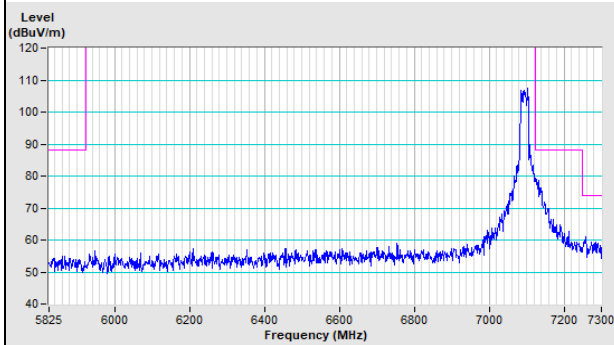

Vertical (Average)

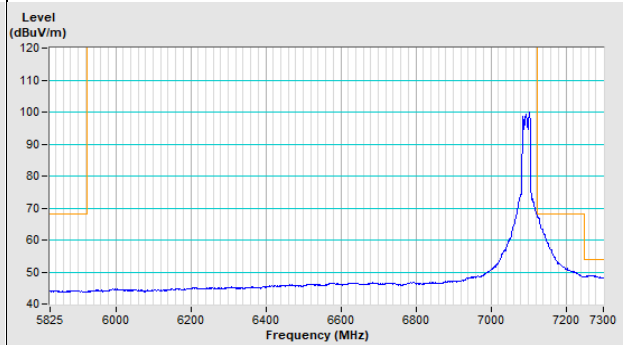

### 802.11ax (HE20) Channel 233

Horizontal (Peak)

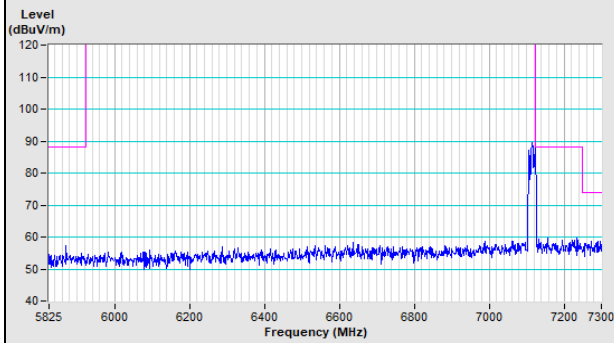

Horizontal (Average)

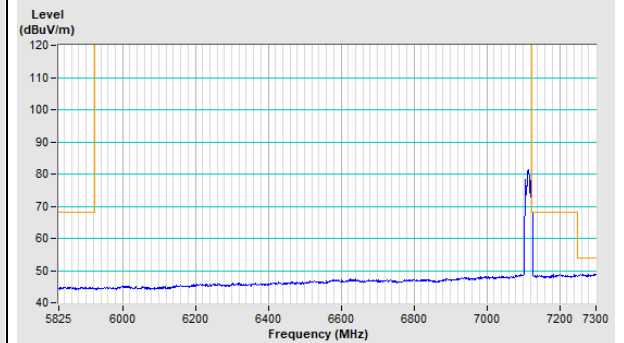

Vertical (Peak)

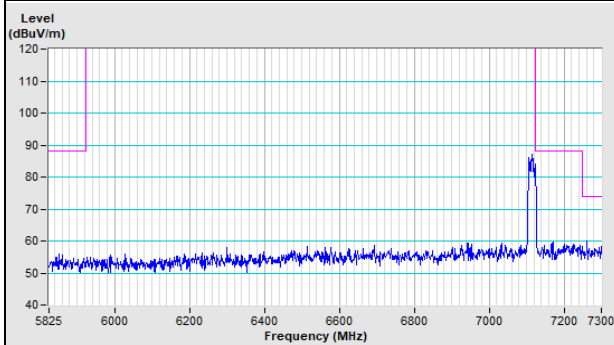

Vertical (Average)

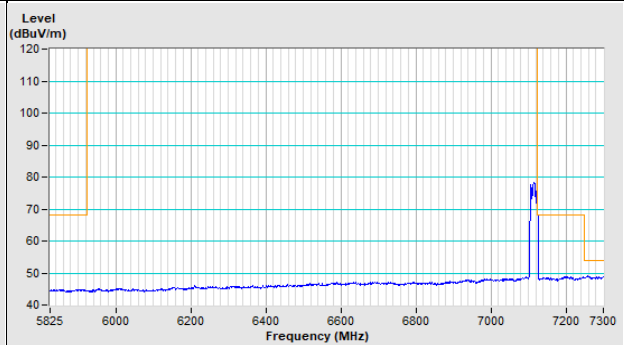

**802.11ax (HE40) Channel 3**

<b>Horizontal (Peak)</b>	<b>Horizontal (Average)</b>
--------------------------	-----------------------------

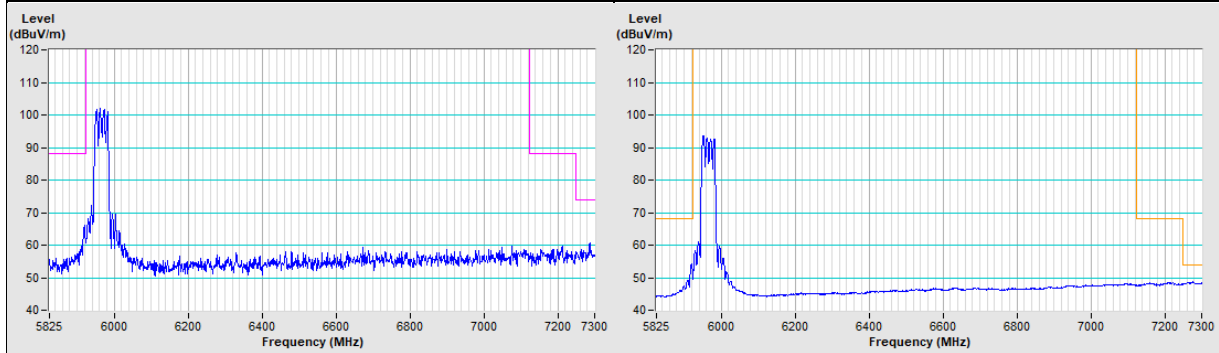

<b>Vertical (Peak)</b>	<b>Vertical (Average)</b>
------------------------	---------------------------

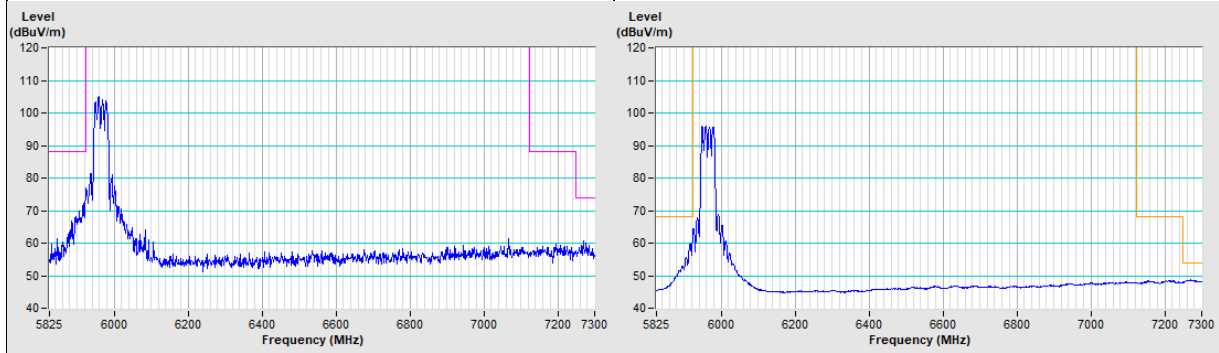

**802.11ax (HE40) Channel 187**

<b>Horizontal (Peak)</b>	<b>Horizontal (Average)</b>
--------------------------	-----------------------------

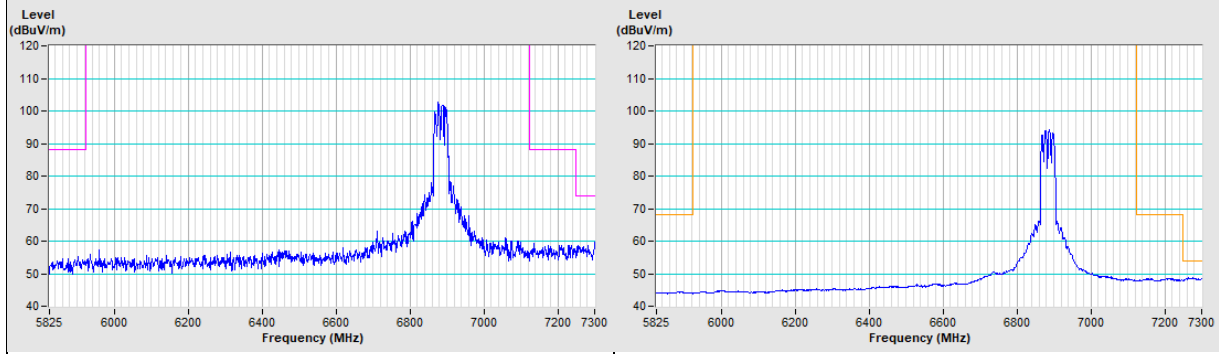

<b>Vertical (Peak)</b>	<b>Vertical (Average)</b>
------------------------	---------------------------

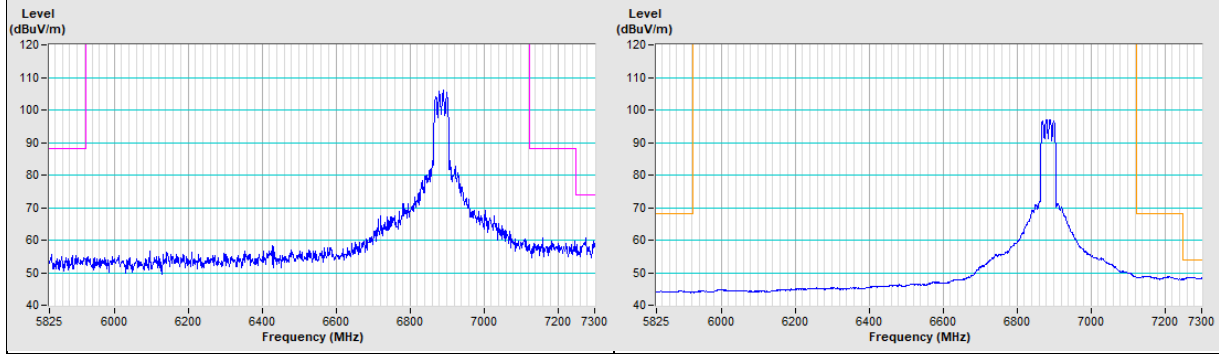

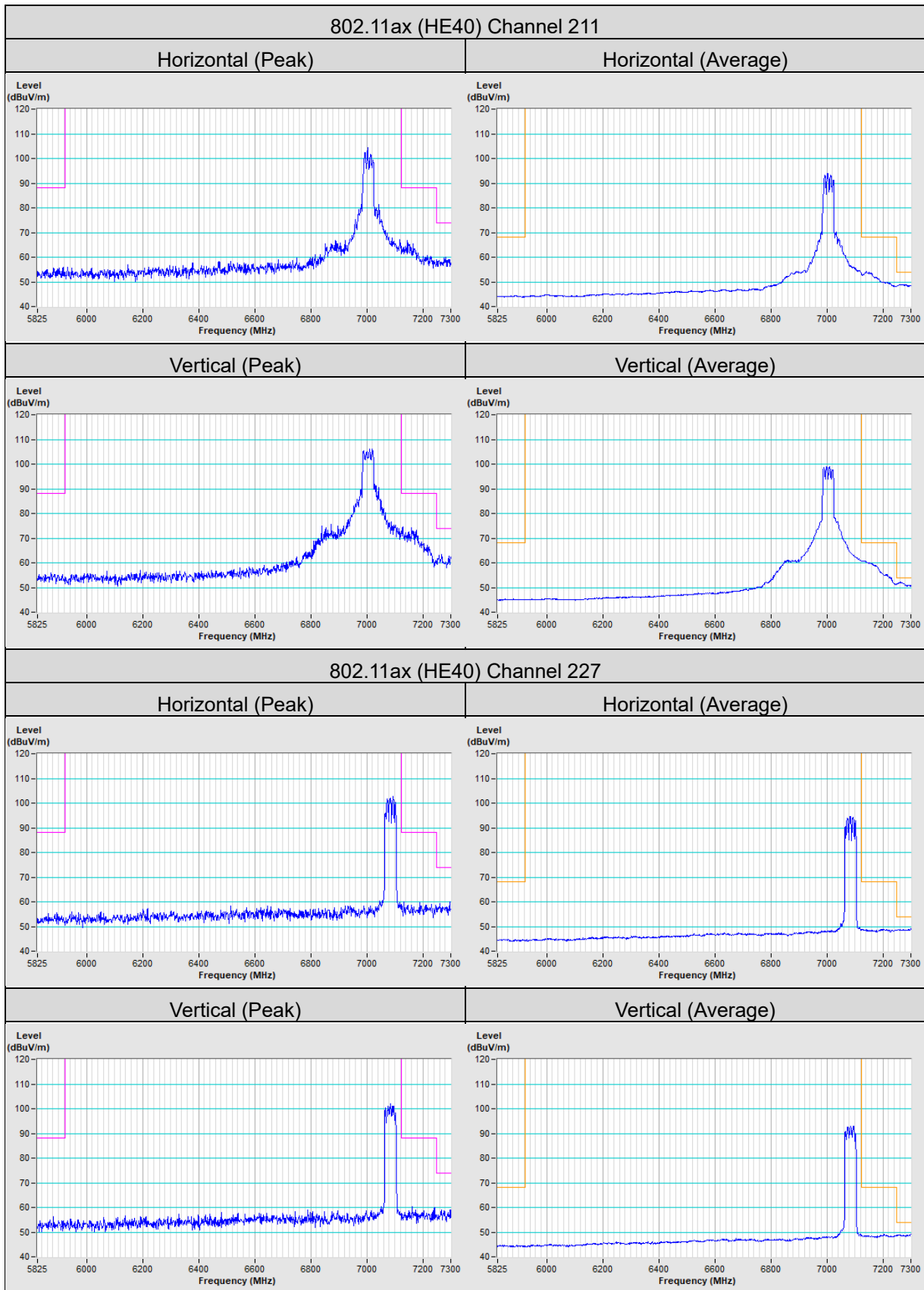

**802.11ax (HE80) Channel 7**

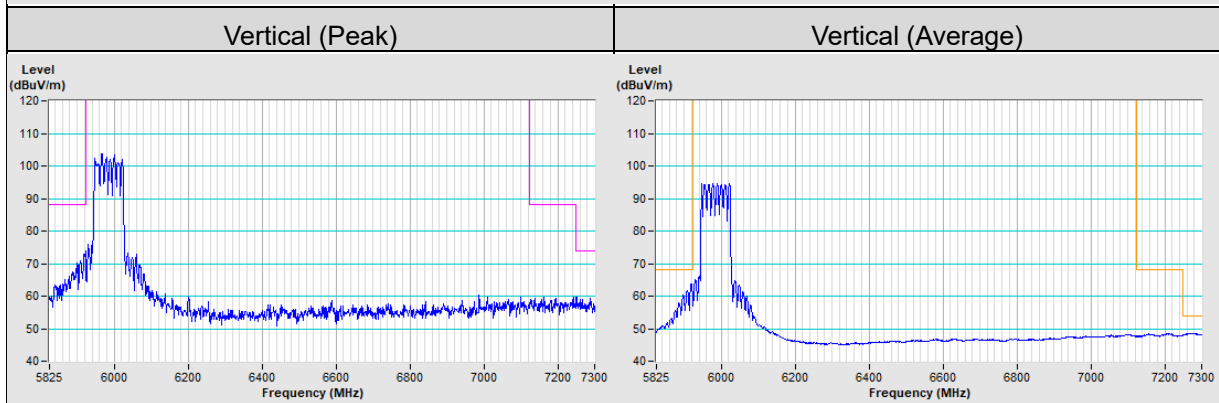
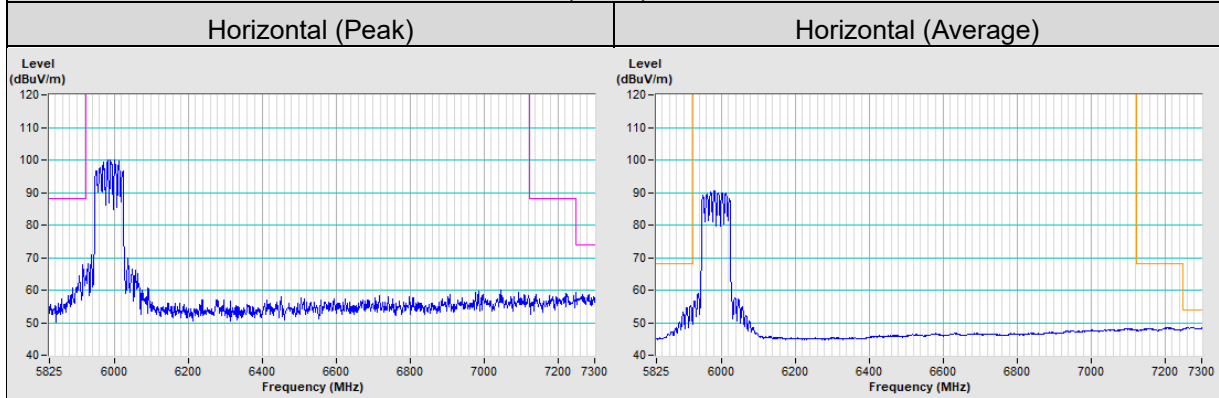

**802.11ax (HE80) Channel 215**

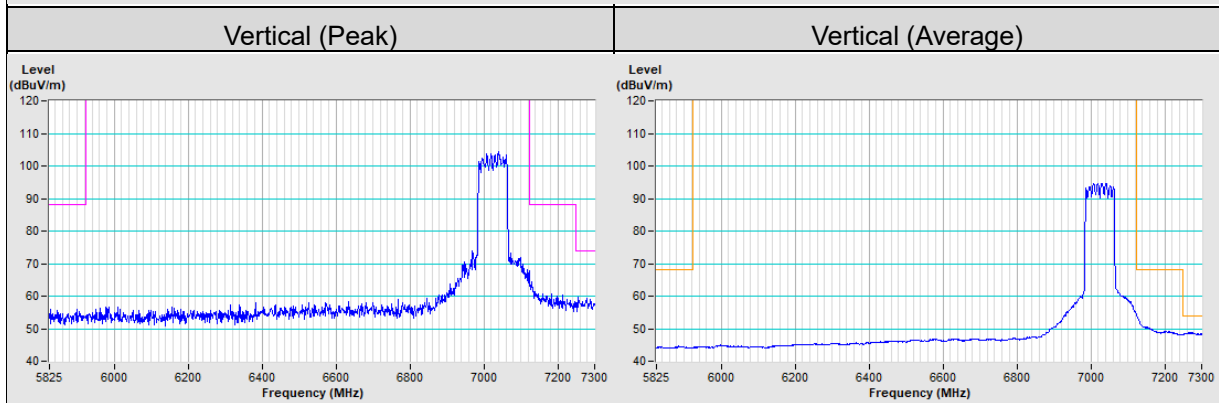
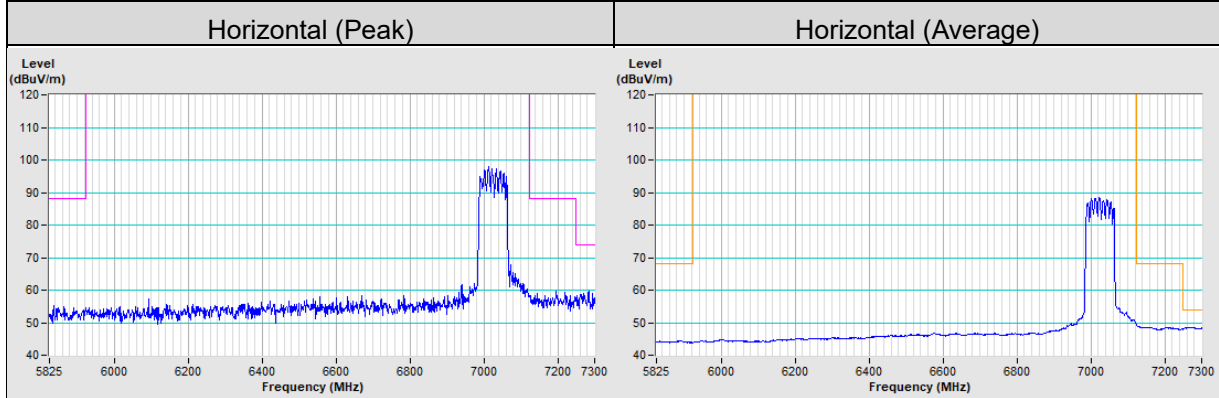

**802.11ax (HE160) Channel 15**

<b>Horizontal (Peak)</b>	<b>Horizontal (Average)</b>
--------------------------	-----------------------------

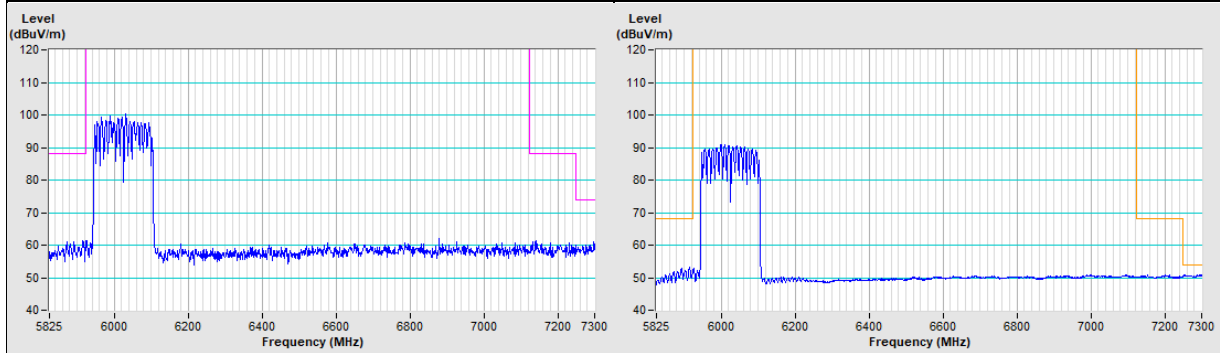

<b>Vertical (Peak)</b>	<b>Vertical (Average)</b>
------------------------	---------------------------

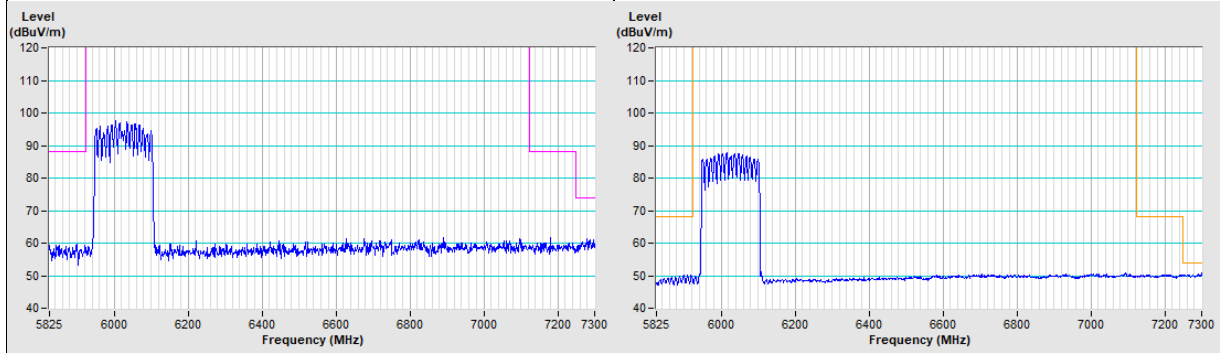

**802.11ax (HE160) Channel 207**

<b>Horizontal (Peak)</b>	<b>Horizontal (Average)</b>
--------------------------	-----------------------------

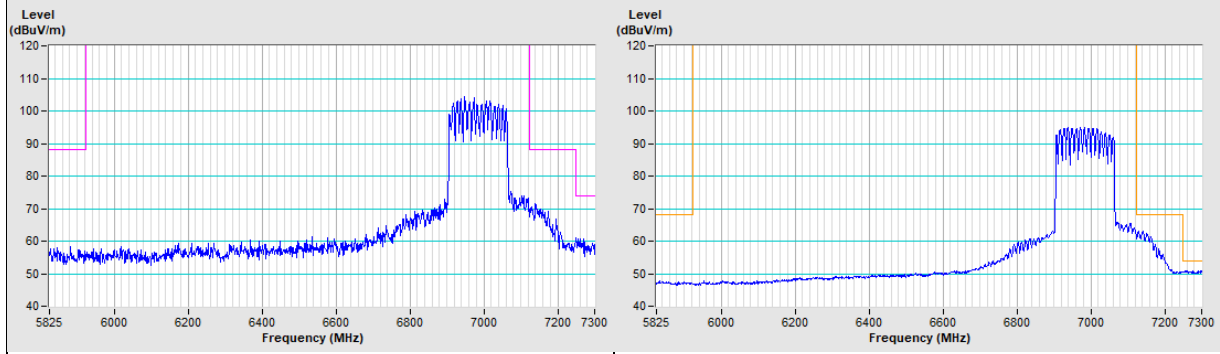

<b>Vertical (Peak)</b>	<b>Vertical (Average)</b>
------------------------	---------------------------

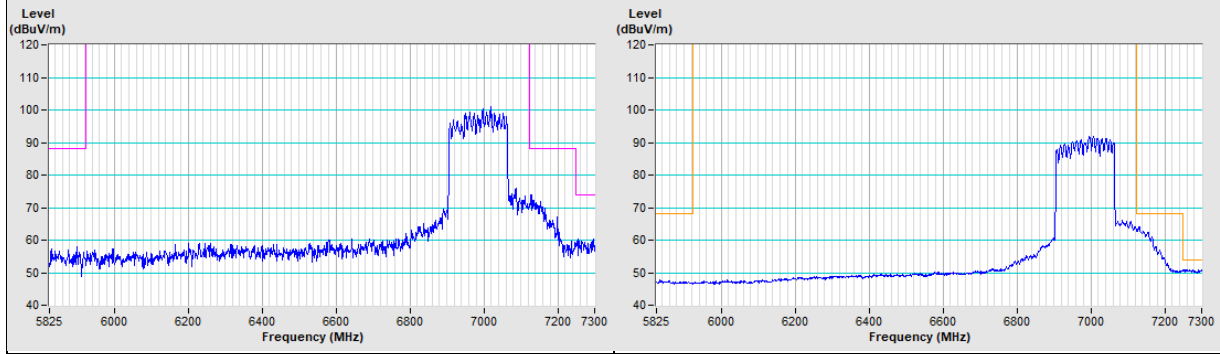

20MHz Preamble 802.11ax (RU26/0) Channel 1

Horizontal (Peak)

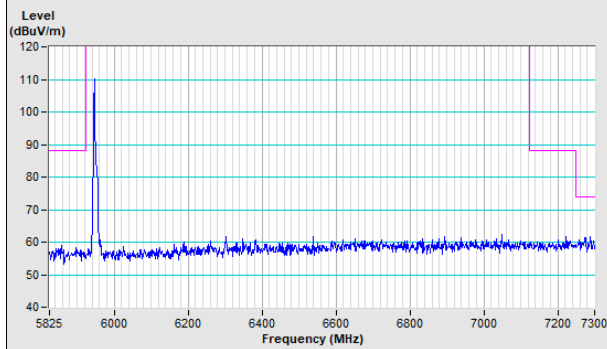

Horizontal (Average)

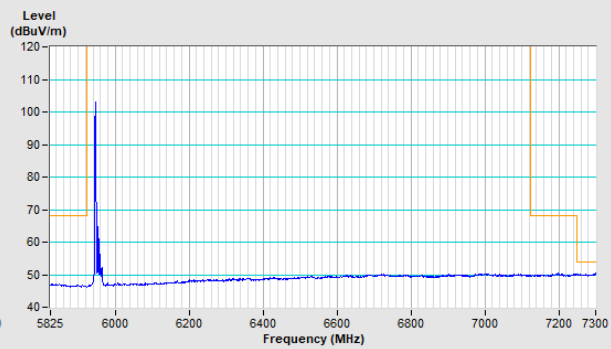

Vertical (Peak)

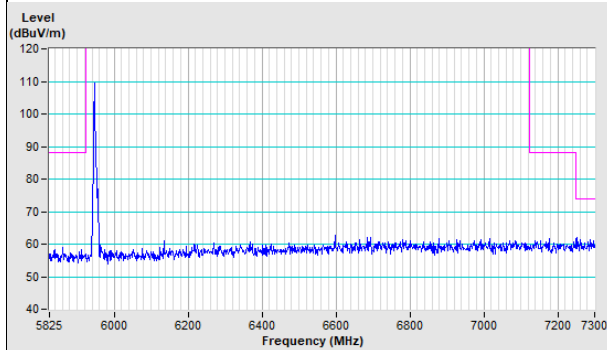

Vertical (Average)

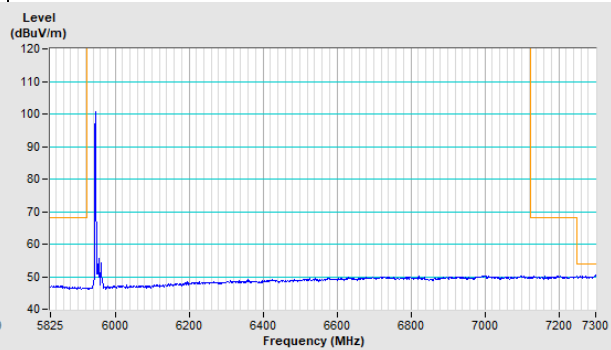

20MHz Preamble 802.11ax (RU52/37) Channel 1

Horizontal (Peak)

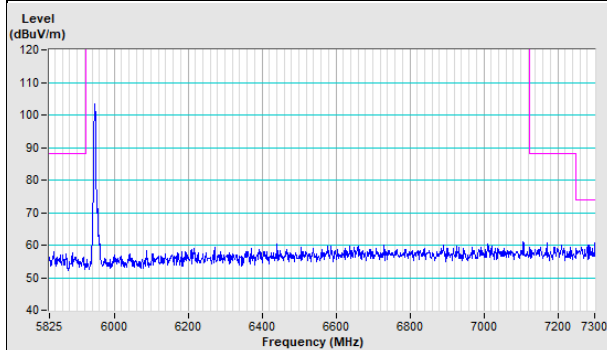

Horizontal (Average)

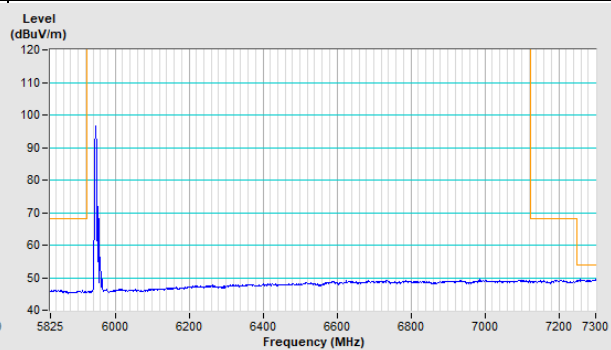

Vertical (Peak)

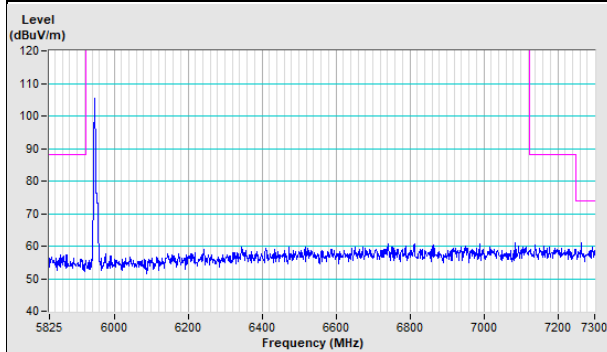

Vertical (Average)

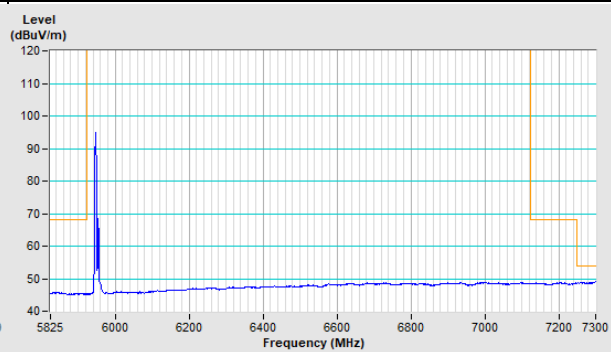

20MHz Preamble 802.11ax (RU106/53) Channel 1

Horizontal (Peak)

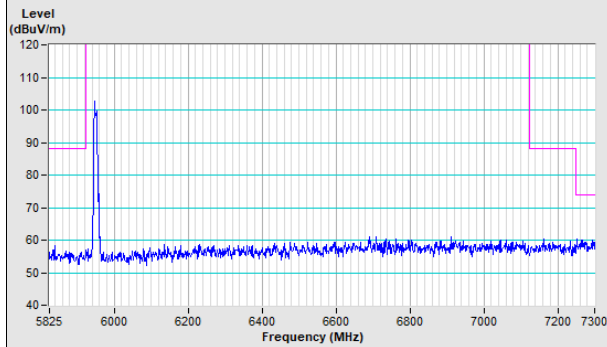

Horizontal (Average)

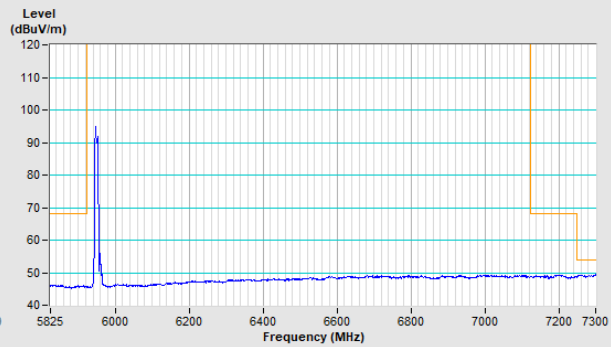

Vertical (Peak)

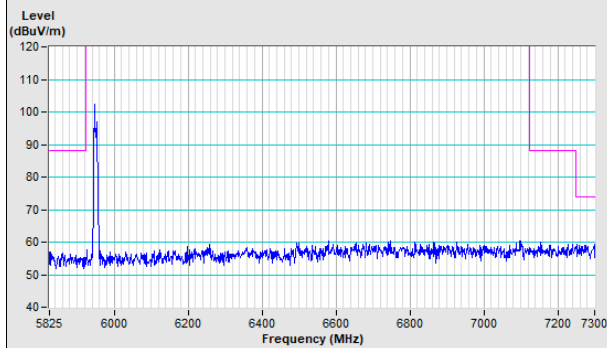

Vertical (Average)

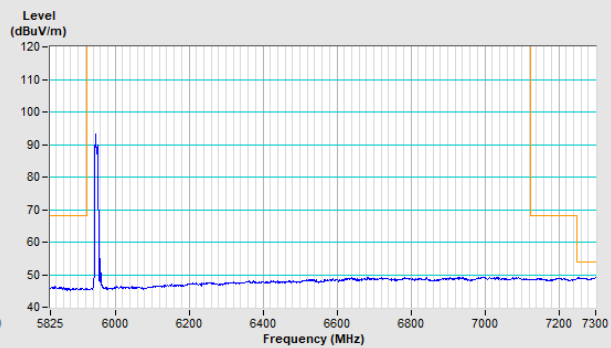

20MHz Preamble 802.11ax (RU242) Channel 1

Horizontal (Peak)

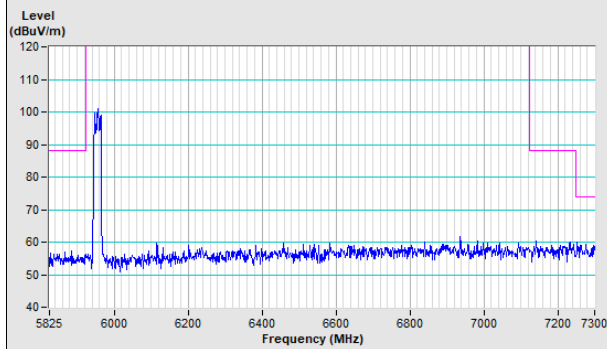

Horizontal (Average)

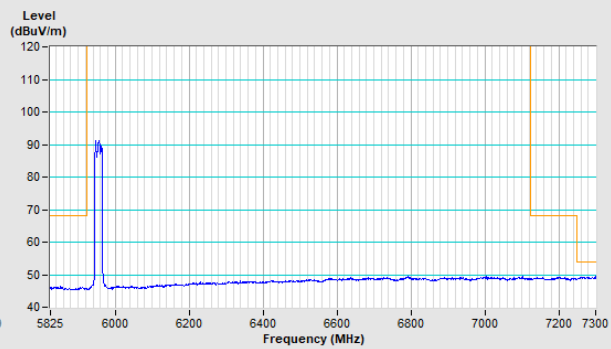

Vertical (Peak)

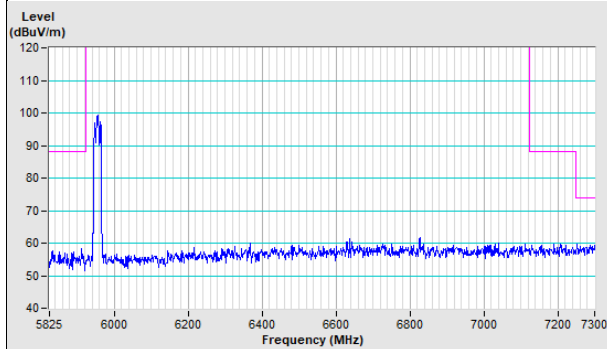

Vertical (Average)

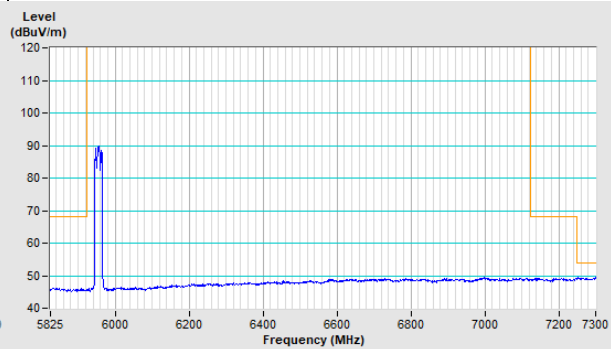



20MHz Preamble 802.11ax (RU26/8) Channel 233

Horizontal (Peak)

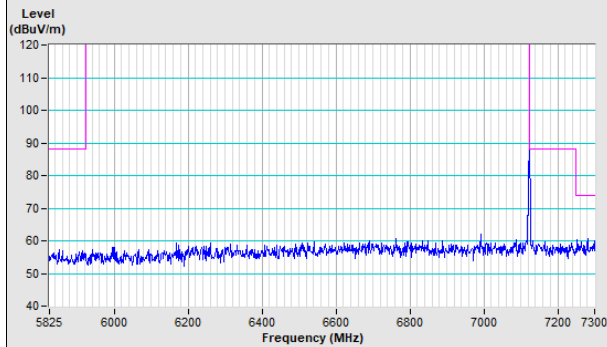

Horizontal (Average)

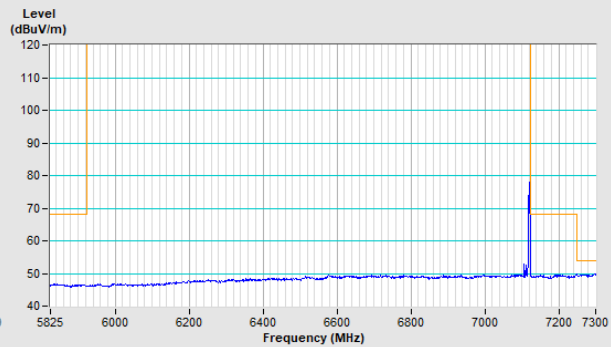

Vertical (Peak)

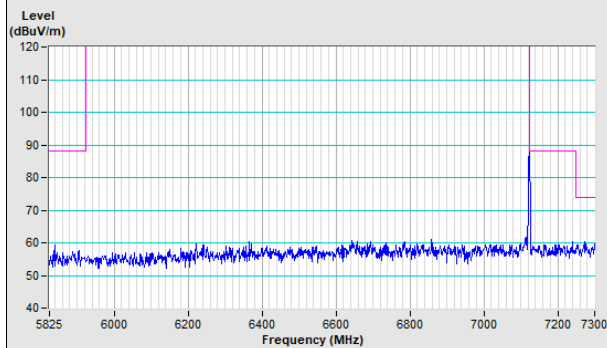

Vertical (Average)

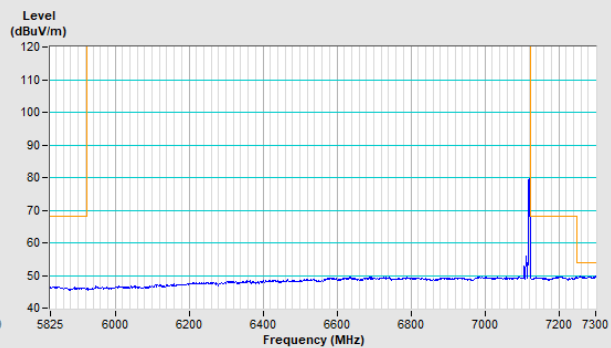

20MHz Preamble 802.11ax (RU52/40) Channel 233

Horizontal (Peak)

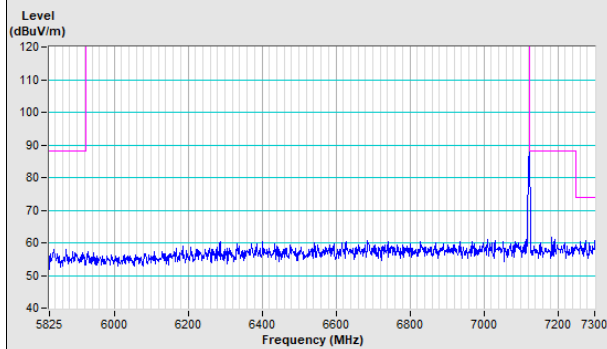

Horizontal (Average)

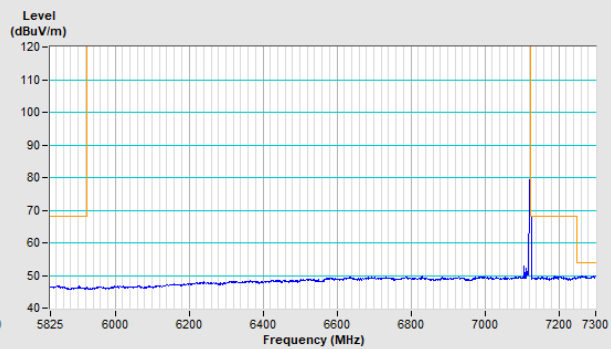

Vertical (Peak)

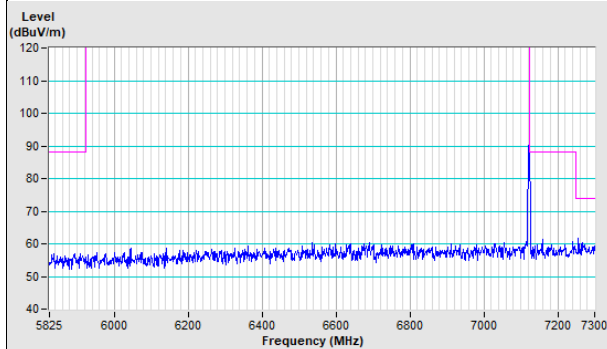

Vertical (Average)

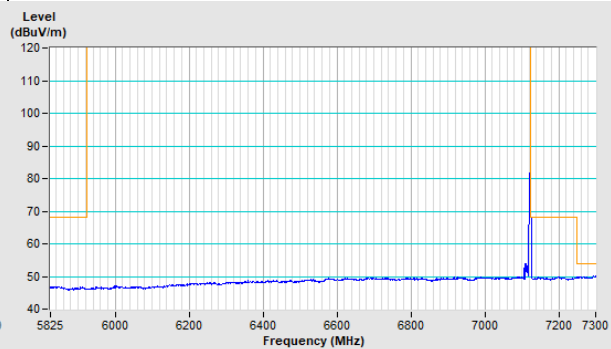

20MHz Preamble 802.11ax (RU106/54) Channel 233

Horizontal (Peak)

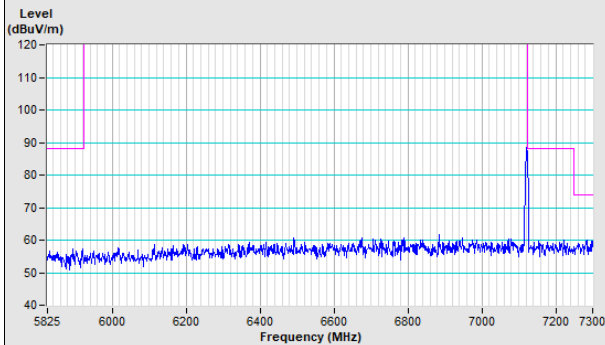

Horizontal (Average)

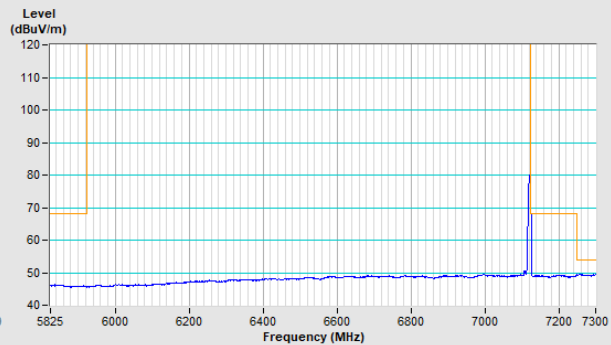

Vertical (Peak)

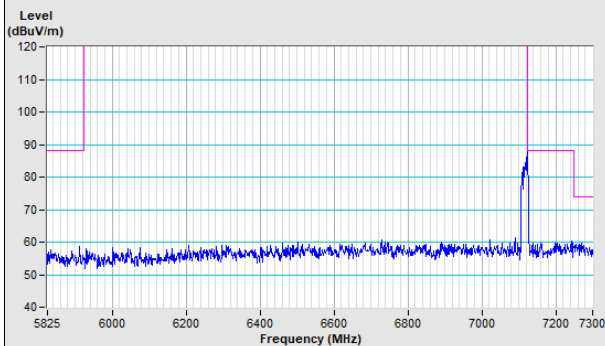

Vertical (Average)

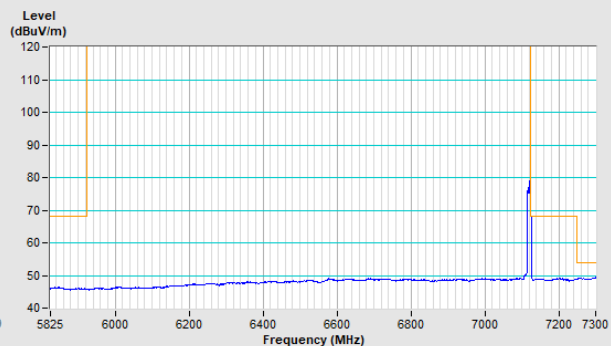

20MHz Preamble 802.11ax (RU242) Channel 233

Horizontal (Peak)

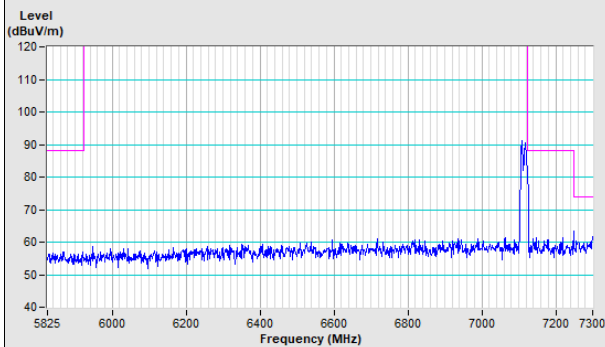

Horizontal (Average)

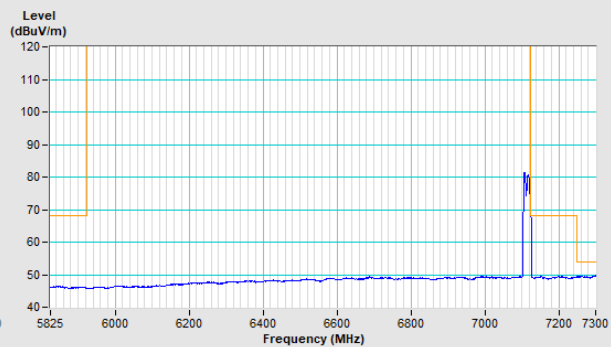

Vertical (Peak)

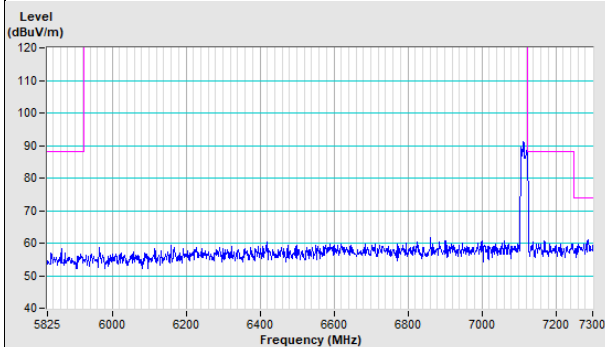

Vertical (Average)

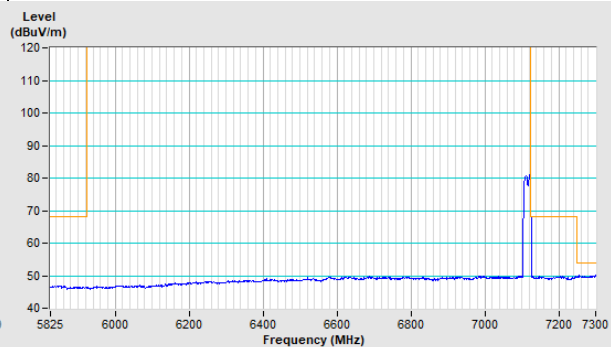

### 40MHz Preamble 802.11ax (RU484) Channel 3

Horizontal (Peak)

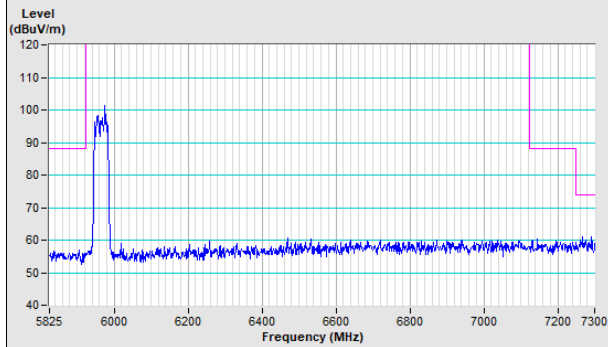

Horizontal (Average)

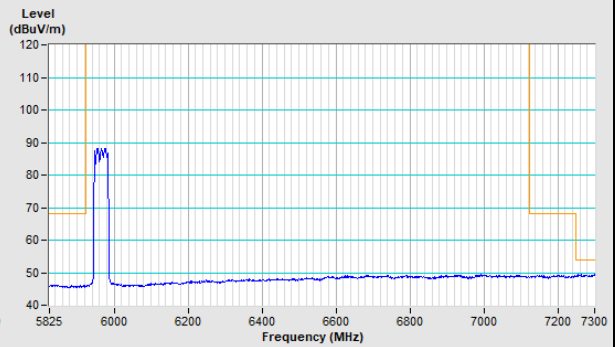

Vertical (Peak)

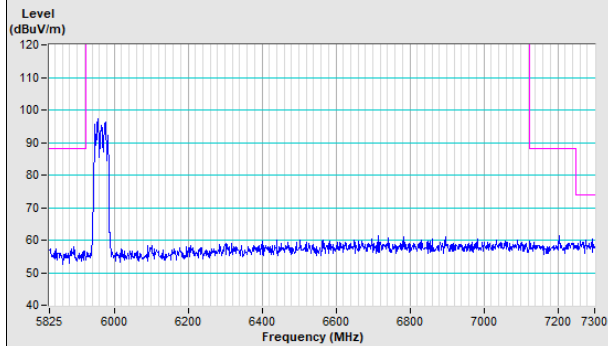

Vertical (Average)

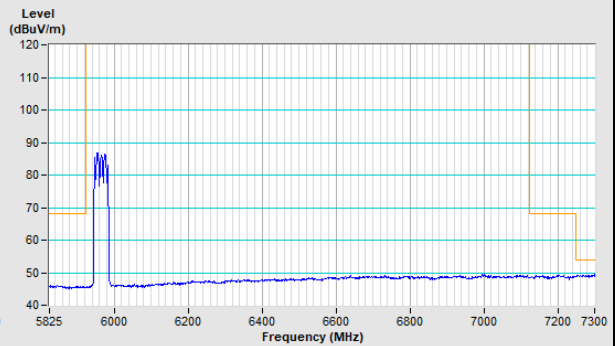

### 40MHz Preamble 802.11ax (RU484) Channel 227

Horizontal (Peak)

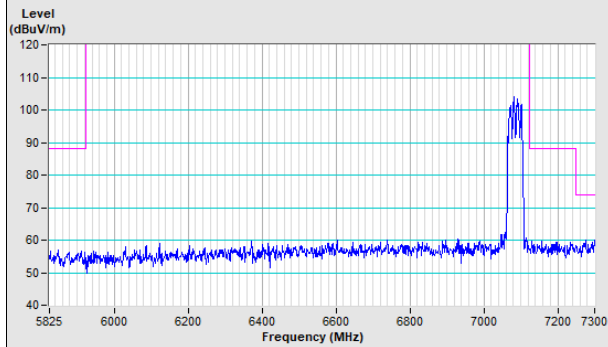

Horizontal (Average)

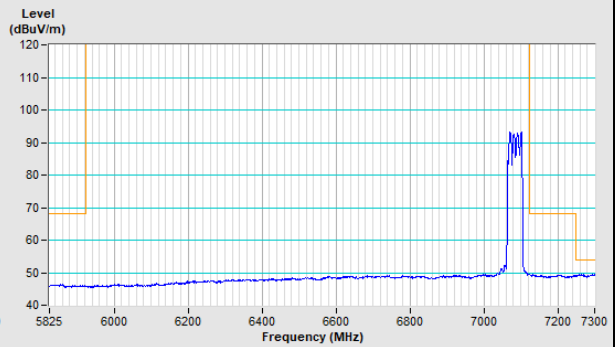

Vertical (Peak)

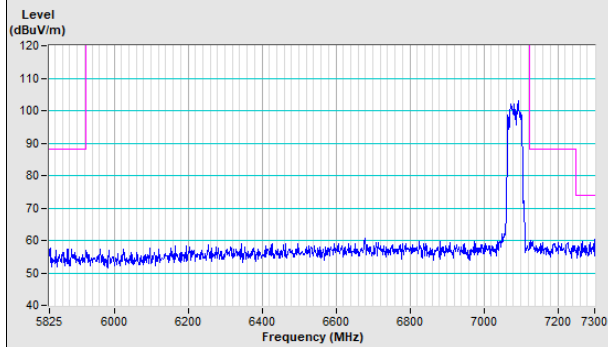

Vertical (Average)

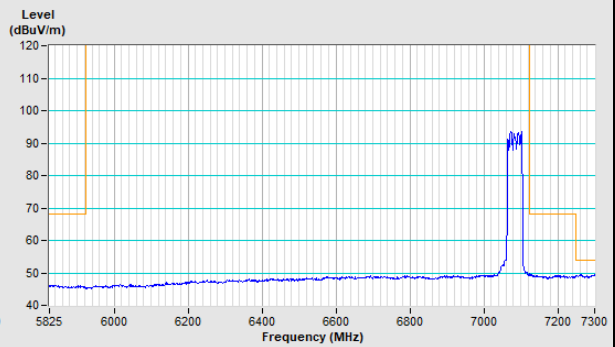

### 80MHz Preamble 802.11ax (RU996) Channel 7

Horizontal (Peak)

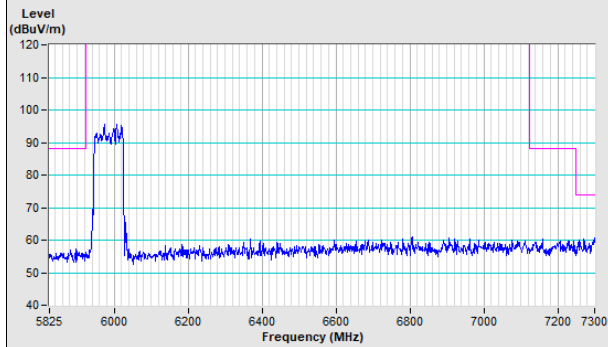

Horizontal (Average)

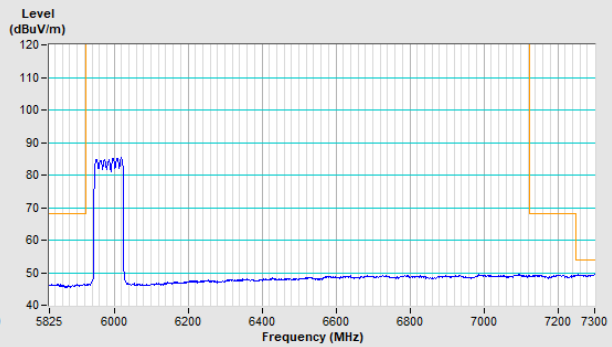

Vertical (Peak)

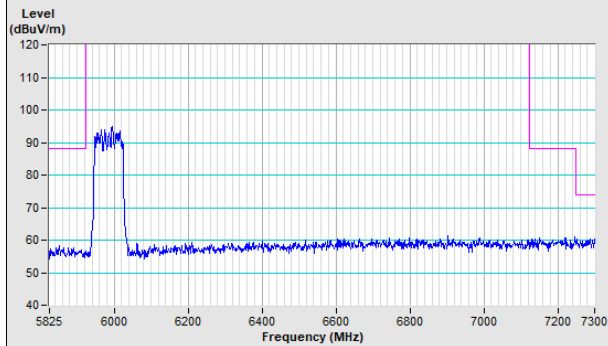

Vertical (Average)

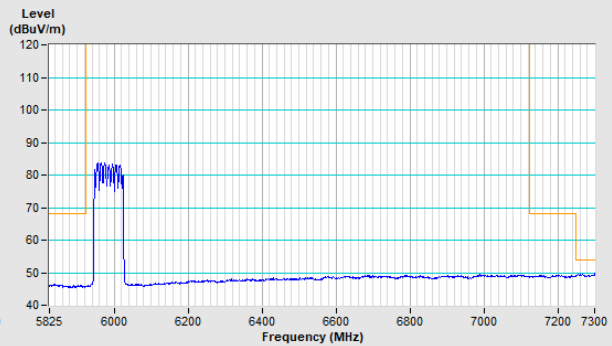

### 80MHz Preamble 802.11ax (RU996) Channel 215

Horizontal (Peak)

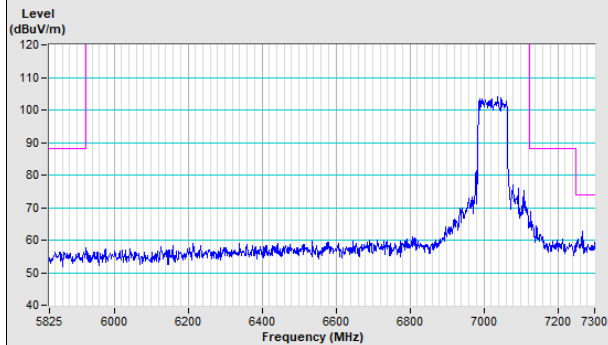

Horizontal (Average)

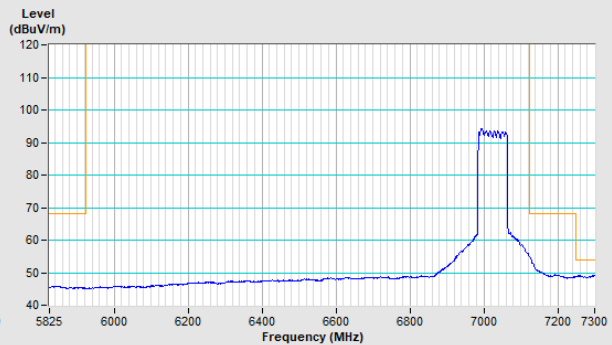

Vertical (Peak)

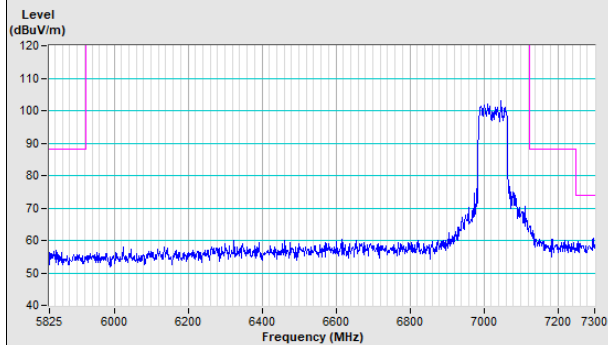

Vertical (Average)

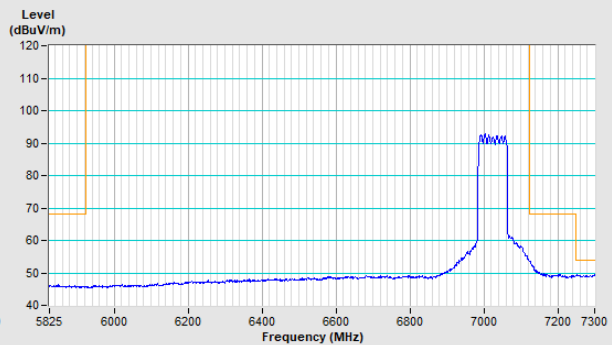

160MHz Preamble 802.11ax (RU996\*2) Channel 15

Horizontal (Peak)

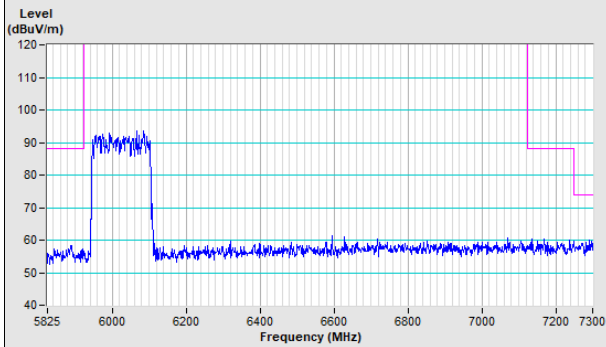

Horizontal (Average)

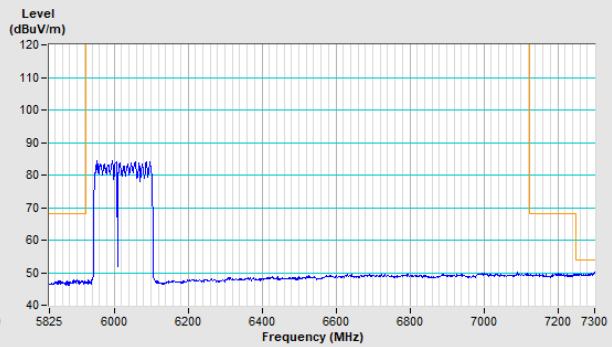

Vertical (Peak)

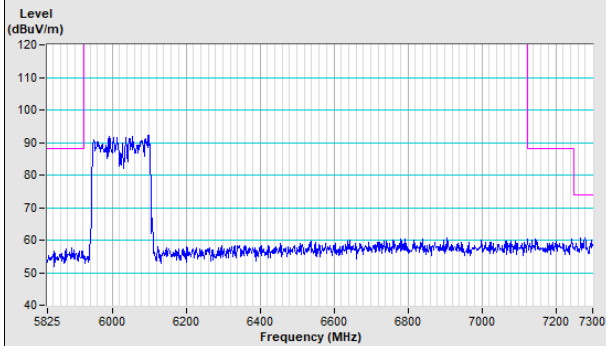

Vertical (Average)

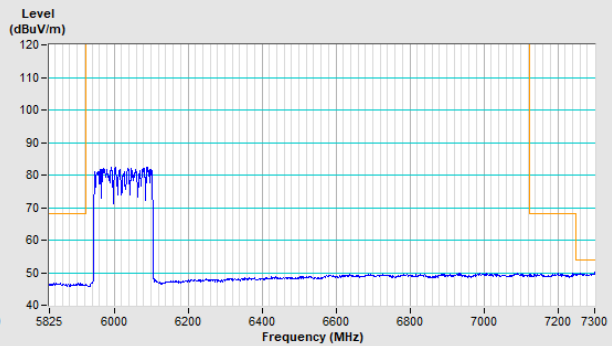

160MHz Preamble 802.11ax (RU996\*2) Channel 207

Horizontal (Peak)

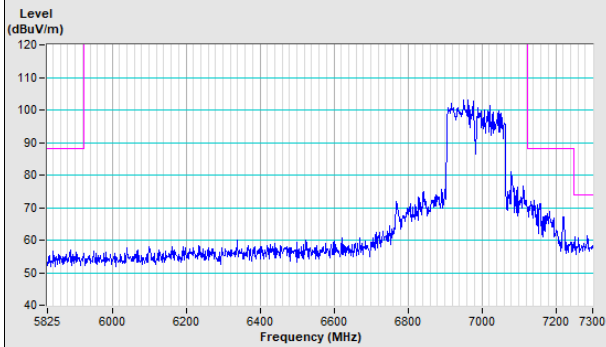

Horizontal (Average)

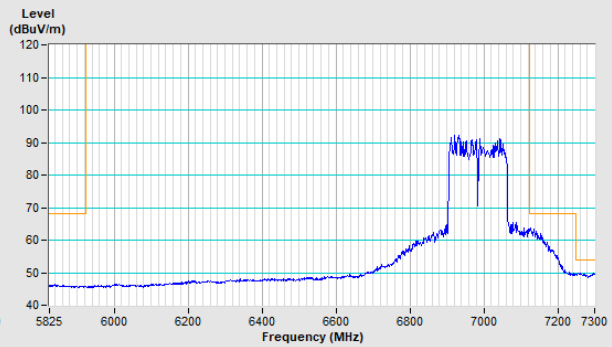

Vertical (Peak)

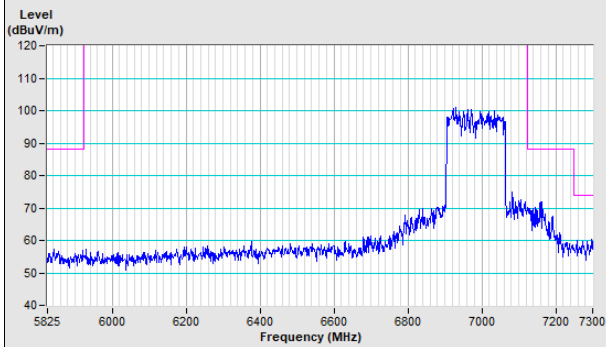

Vertical (Average)

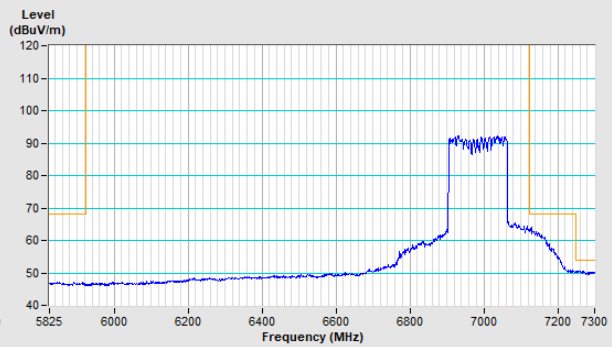

## Appendix A– Information of the Testing Laboratories

We, Bureau Veritas Consumer Products Services (H.K.) Ltd., Taoyuan Branch, were founded in 1988 to provide our best service in EMC, Radio, Telecom and Safety consultation. Our laboratories are FCC recognized accredited test firms and accredited according to ISO/IEC 17025.

If you have any comments, please feel free to contact us at the following:

**Lin Kou EMC/RF Lab**

Tel: 886-2-26052180

Fax: 886-2-26051924

**Hsin Chu EMC/RF/Telecom Lab**

Tel: 886-3-6668565

Fax: 886-3-6668323

**Hwa Ya EMC/RF/Safety Lab**

Tel: 886-3-3183232

Fax: 886-3-3270892

**Email:** [service.adt@tw.bureauveritas.com](mailto:service.adt@tw.bureauveritas.com)

**Web Site:** [www.bureauveritas-adt.com](http://www.bureauveritas-adt.com)

The address and road map of all our labs can be found in our web site also.

--- END ---