

FCC Test Report

(PART 24)

Report No.: RF171218C14-1

FCC ID: NM82Q55200

Test Model: 2Q55200

Received Date: Dec. 18, 2017

Test Date: Dec. 21, 2017 ~ Jan. 22, 2018

Issued Date: Feb. 06, 2018

Applicant: HTC Corporation

Address: 88 Section 3, Zhongxing Road, Xindian District, New Taipei City 231, Taiwan

Issued By: Bureau Veritas Consumer Products Services (H.K.) Ltd., Taoyuan Branch

Lab Address: No. 47-2, 14th Ling, Chia Pau Vil., Lin Kou Dist., New Taipei City, Taiwan
(R.O.C)

Test Location (1): No. 19, Hwa Ya 2nd Rd, Wen Hwa Tsuen, Kwei Shan Hsiang, Taoyuan
Hsien 333, Taiwan, R.O.C.

Test Location (2): No.215, Sec. 3, Beixin Rd., Xindian Dist., New Taipei City 231, Taiwan,
R.O.C

**FCC Registration /
Designation Number:** 427177 / TW0011



This report is for your exclusive use. Any copying or replication of this report to or for any other person or entity, or use of our name or trademark, is permitted only with our prior written permission. This report sets forth our findings solely with respect to the test samples identified herein. The results set forth in this report are not indicative or representative of the quality or characteristics of the lot from which a test sample was taken or any similar or identical product unless specifically and expressly noted. Our report includes all of the tests requested by you and the results thereof based upon the information that you provided to us. You have 60 days from date of issuance of this report to notify us of any material error or omission caused by our negligence, provided, however, that such notice shall be in writing and shall specifically address the issue you wish to raise. A failure to raise such issue within the prescribed time shall constitute your unqualified acceptance of the completeness of this report, the tests conducted and the correctness of the report contents. Unless specific mention, the uncertainty of measurement has been explicitly taken into account to declare the compliance or non-compliance to the specification. The report must not be used by the client to claim product certification, approval, or endorsement by TAF or any government agencies.

Table of Contents

Release Control Record	3
1 Certificate of Conformity	4
2 Summary of Test Results.....	5
2.1 Measurement Uncertainty.....	5
2.2 Test Site And Instruments	6
3 General Information	8
3.1 General Description of EUT	8
3.2 Configuration of System under Test.....	9
3.2.1 Description of Support Units	10
3.3 Test Mode Applicability and Tested Channel Detail	11
3.4 EUT Operating Conditions	14
3.5 General Description of Applied Standards.....	14
4 Test Types and Results	15
4.1 Output Power Measurement.....	15
4.1.1 Limits of Output Power Measurement	15
4.1.2 Test Procedures.....	15
4.1.3 Test Setup.....	16
4.1.4 Test Results	17
4.2 Frequency Stability Measurement	26
4.2.1 Limits of Frequency Stability Measurement.....	26
4.2.2 Test Procedure	26
4.2.3 Test Setup.....	26
4.2.4 Test Results	27
4.3 Occupied Bandwidth Measurement.....	36
4.3.1 Test Procedure	36
4.3.2 Test Setup.....	36
4.3.3 Test Result	37
4.4 Band Edge Measurement	41
4.4.1 Limits of Band Edge Measurement	41
4.4.2 Test Setup.....	41
4.4.3 Test Procedures.....	41
4.4.4 Test Results	42
4.5 Peak to Average Ratio	49
4.5.1 Limits of Peak to Average Ratio Measurement	49
4.5.2 Test Setup.....	49
4.5.3 Test Procedures.....	49
4.5.4 Test Results	50
4.6 Conducted Spurious Emissions.....	54
4.6.1 Limits of Conducted Spurious Emissions Measurement.....	54
4.6.2 Test Setup.....	54
4.6.3 Test Procedure	54
4.6.4 Test Results	55
4.7 Radiated Emission Measurement.....	82
4.7.1 Limits of Radiated Emission Measurement	82
4.7.2 Test Procedure	82
4.7.3 Deviation from Test Standard	82
4.7.4 Test Setup.....	83
4.7.5 Test Results	84
5 Pictures of Test Arrangements.....	108
Appendix – Information on the Testing Laboratories	109

Release Control Record

Issue No.	Description	Date Issued
RF171218C14-1	Original Release	Feb. 06, 2018

1 Certificate of Conformity

Product: Smartphone

Brand: HTC

Test Model: 2Q55200

Sample Status: Production Unit

Applicant: HTC Corporation

Test Date: Dec. 21, 2017 ~ Jan. 22, 2018

Standards: FCC Part 24, Subpart E

The above equipment has been tested by **Bureau Veritas Consumer Products Services (H.K.) Ltd., Taoyuan Branch**, and found compliance with the requirement of the above standards. The test record, data evaluation & Equipment Under Test (EUT) configurations represented herein are true and accurate accounts of the measurements of the sample's RF characteristics under the conditions specified in this report.

Prepared by : , **Date:** Feb. 06, 2018
Ivonne Wu / Supervisor

Approved by : , **Date:** Feb. 06, 2018
Dylan Chiou / Project Engineer

2 Summary of Test Results

Applied Standard: FCC Part 24 & Part 2			
FCC Clause	Test Item	Result	Remarks
2.1046 24.232	Effective Isotropic Radiated Power	Pass	Meet the requirement of limit.
2.1046 24.232(d)	Peak to Average Ratio	Pass	Meet the requirement of limit.
2.1055 24.235	Frequency Stability	Pass	Meet the requirement of limit.
2.1049 24.238(b)	Occupied Bandwidth	Pass	Meet the requirement of limit.
24.238(b)	Band Edge Measurements	Pass	Meet the requirement of limit.
2.1051 24.238	Conducted Spurious Emissions	Pass	Meet the requirement of limit.
2.1053 24.238	Radiated Spurious Emissions	Pass	Meet the requirement of limit. Minimum passing margin is -36.36 dB at 3819.60 MHz.

2.1 Measurement Uncertainty

Where relevant, the following measurement uncertainty levels have been estimated for tests performed on the EUT as specified in CISPR 16-4-2:

Measurement	Frequency	Expanded Uncertainty (k=2) (±)
Radiated Emissions up to 1 GHz	30 MHz ~ 200 MHz	2.0153 dB
	200 MHz ~ 1000 MHz	2.0224 dB
Radiated Emissions above 1 GHz	1 GHz ~ 18 GHz	1.0121 dB
	18 GHz ~ 40 GHz	1.1508 dB

2.2 Test Site And Instruments

Description & Manufacturer	Model No.	Serial No.	Date of Calibration	Due Date of Calibration
Signal Analyzer Keysight	N9010A	MY56070348	Sep. 13, 2017	Sep. 12, 2018
Spectrum Analyzer ROHDE & SCHWARZ	FSW26	102023	Aug. 21, 2017	Aug. 20, 2018
BILOG Antenna SCHWARZBECK	VULB9168	9168-472	Dec. 06, 2017	Dec. 05, 2018
HORN Antenna ETS-Lindgren	3117	00143293	Jun. 26, 2017	Jun. 25, 2018
Double Ridge Guide Horn Antenna EMCO	3115	5619	Nov. 30, 2017	Nov. 29, 2018
BILOG Antenna SCHWARZBECK	VULB 9168	9168-153	Dec. 06, 2017	Dec. 05, 2018
HORN Antenna SCHWARZBECK	BBHA 9170	9170-480	Dec. 01, 2017	Nov. 30, 2018
Fixed Attenuator Mini-Circuits	BW-N10W5+	NA	Jul. 07, 2017	Jul. 06, 2018
MXG Vector signal generator Agilent	N5182B	MY53050430	Oct. 24, 2017	Oct. 23, 2018
Preamplifier Agilent	310N	187226	Jun. 23, 2017	Jun. 22, 2018
Preamplifier Agilent	83017A	MY39501357	Jun. 23, 2017	Jun. 22, 2018
Power Meter Anritsu	ML2495A	1012010	Aug. 15, 2017	Aug. 14, 2018
Power Sensor Anritsu	MA2411B	1315050	Aug. 15, 2017	Aug. 14, 2018
RF signal cable ETS-LINDGREN	5D-FB	Cable-CH1-01(R FC-SMS-100-SM S-120+RFC-SMS -100-SMS-400)	Jun. 26, 2017	Jun. 25, 2018
RF signal cable ETS-LINDGREN	8D-FB	Cable-CH1-02(R FC-SMS-100-SM S-24)	Jun. 26, 2017	Jun. 25, 2018
Software BV ADT	E3 8.130425b	NA	NA	NA
Antenna Tower MF	NA	NA	NA	NA
Turn Table MF	NA	NA	NA	NA
Antenna Tower & Turn Table Controller MF	MF-7802	NA	NA	NA
Communications Tester-Wireless Agilent	8960 Series 10	MY53201073	Jun. 28, 2017	Jun. 27, 2019
DC Power Supply Topward	33010D	807748	Oct. 25, 2016	Oct. 24, 2018
Digital Multimeter Fluke	87-III	70360742	Jun. 30, 2017	Jun. 29, 2018

- Note:
1. The calibration interval of the above test instruments is 12 / 24 months and the calibrations are traceable to NML/ROC and NIST/USA.
 2. The test was performed in HsinTien Chamber 1.
 3. The horn antenna and preamplifier (model: 83017A) are used only for the measurement of emission frequency above 1 GHz if tested.
 4. The IC Site Registration No. is IC7450I-1.



3 General Information

3.1 General Description of EUT

Product	Smartphone	
Brand	HTC	
Test Model	2Q55200	
Status of EUT	Production Unit	
Power Supply Rating	5 Vdc or 9 Vdc or 12 Vdc (adapter) 5.0 Vdc (host equipment) 3.85 Vdc (Li-ion battery)	
Modulation Type	GSM/GPRS	GMSK
	EDGE	GMSK, 8PSK
	WCDMA	QPSK
	LTE	QPSK, 16QAM, 64QAM
Frequency Range	GSM/GPRS/EDGE	1850.2 ~ 1909.8 MHz
	WCDMA	1852.4 ~ 1907.6 MHz
	LTE Band 2 (Channel Bandwidth: 1.4 MHz)	1850.7 ~ 1909.3 MHz
	LTE Band 2 (Channel Bandwidth: 3 MHz)	1851.5 ~ 1908.5 MHz
	LTE Band 2 (Channel Bandwidth: 5 MHz)	1852.5 ~ 1907.5 MHz
	LTE Band 2 (Channel Bandwidth: 10 MHz)	1855.0 ~ 1905.0 MHz
	LTE Band 2 (Channel Bandwidth: 15 MHz)	1857.5 ~ 1902.5 MHz
	LTE Band 2 (Channel Bandwidth: 20 MHz)	1860.0 ~ 1900.0 MHz
Max. EIRP Power	GSM/GPRS	456.04 mW
	EDGE	182.81 mW
	WCDMA	142.56 mW
	LTE Band 2 (Channel Bandwidth: 1.4 MHz)	162.18 mW
	LTE Band 2 (Channel Bandwidth: 3 MHz)	161.18 mW
	LTE Band 2 (Channel Bandwidth: 5 MHz)	160.07 mW
	LTE Band 2 (Channel Bandwidth: 10 MHz)	161.44 mW
	LTE Band 2 (Channel Bandwidth: 15 MHz)	160.69 mW
Emission Designator	GSM/GPRS	246KGXW
	EDGE	250KG7W
	WCDMA	4M61F9W
	LTE Band 2 (Channel Bandwidth: 1.4 MHz)	1M09W7D
	LTE Band 2 (Channel Bandwidth: 3 MHz)	2M70W7D
	LTE Band 2 (Channel Bandwidth: 5 MHz)	4M49W7D
	LTE Band 2 (Channel Bandwidth: 10 MHz)	8M97W7D
	LTE Band 2 (Channel Bandwidth: 15 MHz)	13M5G7D
	LTE Band 2 (Channel Bandwidth: 20 MHz)	18M0W7D
Antenna Type	Fixed Internal Antenna	
Accessory Device	Refer to Note as below	
Data Cable Supplied	Refer to Note as below	

Note:

1. The EUT's accessories list refers to Ext. Pho.
2. The above EUT information is declared by manufacturer and for more detailed features description, please refer to the manufacturer's specifications or user's manual.

3.2 Configuration of System under Test

For GSM / WCDMA

<Radiated Emission Test>

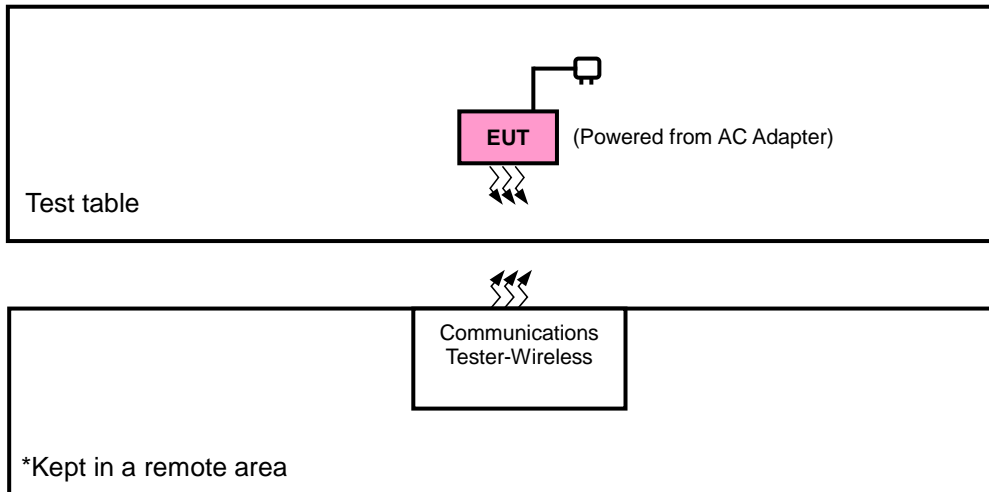

<E.R.P. Test>

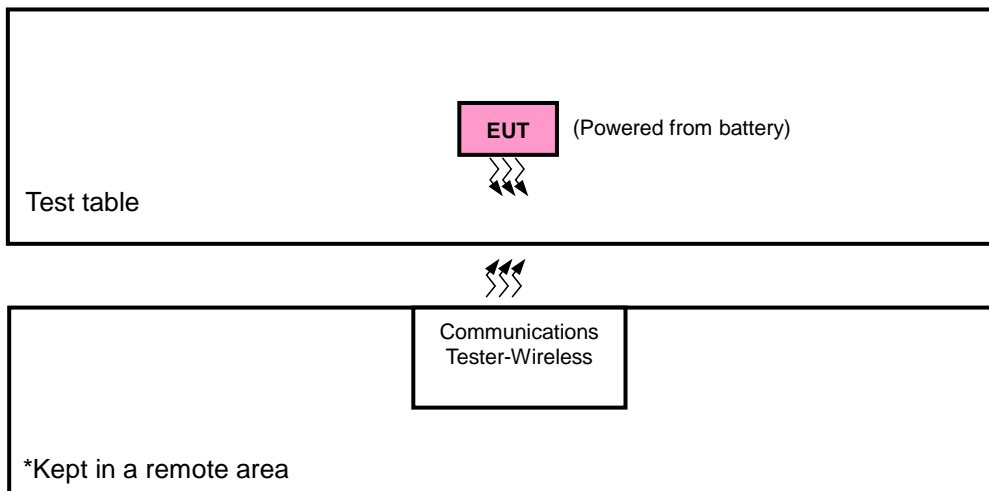

For LTE

<Radiated Emission Test>

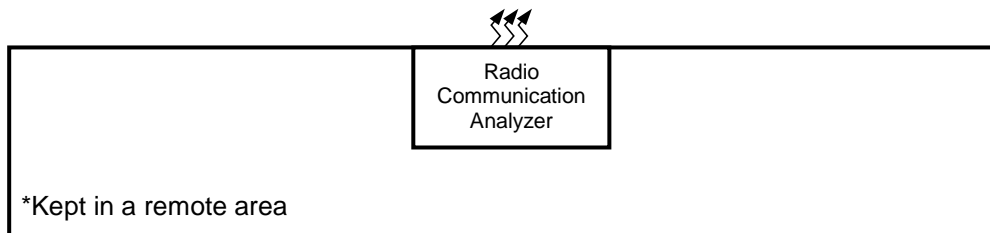
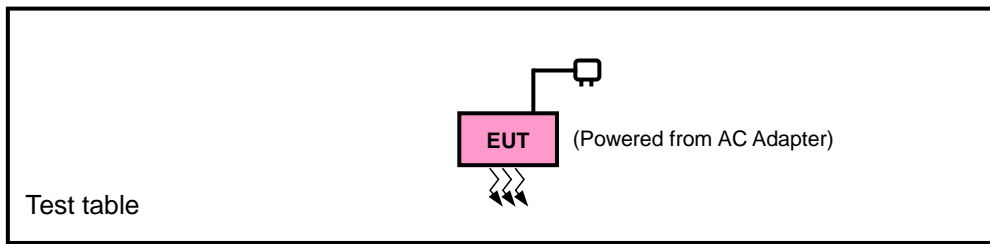

<E.R.P. Test>

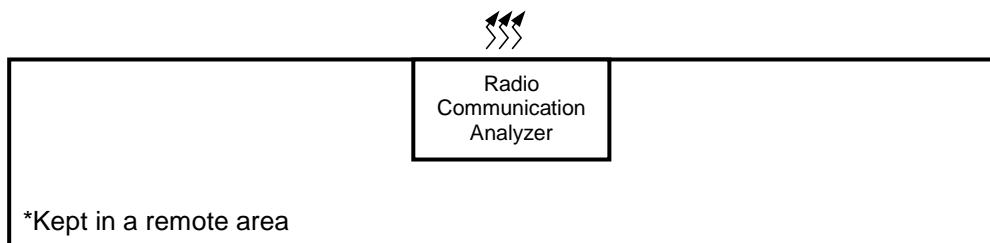
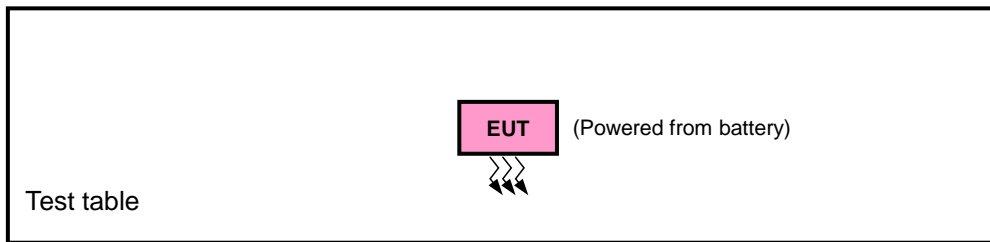

3.2.1 Description of Support Units

The EUT has been tested as an independent unit together with other necessary accessories or support units. The following support units or accessories were used to form a representative test configuration during the tests.

No.	Product	Brand	Model No.	Serial No.	FCC ID
1.	Communications Tester-Wireless	Agilent	8960 Series 10	MY53201073	N/A
2.	Radio Communication Analyzer	Anritsu	MT8820C	6201010284	N/A

No.	Signal Cable Description Of The Above Support Units
1.	N/A
2.	N/A

Note:

1. All power cords of the above support units are non-shielded (1.8m).
2. Items 1~2 acted as communication partners to transfer data.

3.3 Test Mode Applicability and Tested Channel Detail

Pre-Scan has been conducted to determine the worst-case mode from all possible combinations between available modulations, data rates, XYZ axis, and antenna ports.

The worst case was found when positioned as the table below. Following channel(s) was (were) selected for the final test as listed below:

SIM	Band	EIRP	Radiated Emission
1	GSM	X-plane	Y-axis
	EDGE	X-plane	Y-axis
	WCDMA	X-plane	Y-axis
	LTE Band 2	X-plane	Y-axis

GSM

EUT Configure Mode	Test Item	Available Channel	Tested Channel	Mode
-	EIRP	512 to 810	512, 661, 810	GSM, EDGE
-	Frequency Stability	512 to 810	512, 810	GSM, EDGE
-	Occupied Bandwidth	512 to 810	512, 661, 810	GSM, EDGE
-	Band Edge	512 to 810	512, 810	GSM, EDGE
-	Peak to Average Ratio	512 to 810	512, 661, 810	GSM, EDGE
-	Conducted Spurious Emission	512 to 810	512, 661, 810	GSM, EDGE
-	Radiated Emission	512 to 810	512, 661, 810	GSM, EDGE

WCDMA

EUT Configure Mode	Test Item	Available Channel	Tested Channel	Mode
-	EIRP	9262 to 9538	9262, 9400, 9538	WCDMA
-	Frequency Stability	9262 to 9538	9262, 9538	WCDMA
-	Occupied Bandwidth	9262 to 9538	9262, 9400, 9538	WCDMA
-	Band Edge	9262 to 9538	9262, 9538	WCDMA
-	Peak to Average Ratio	9262 to 9538	9262, 9400, 9538	WCDMA
-	Conducted Spurious Emission	9262 to 9538	9262, 9400, 9538	WCDMA
-	Radiated Emission	9262 to 9538	9262, 9400, 9538	WCDMA

LTE Band 2

EUT Configure Mode	Test Item	Available Channel	Tested Channel	Channel Bandwidth	Modulation	Mode
-	EIRP	18607 to 19193	18607, 18900, 19193	1.4 MHz	QPSK, 16QAM, 64QAM	1 RB / 0 RB Offset
		18615 to 19185	18615, 18900, 19185	3 MHz	QPSK, 16QAM, 64QAM	1 RB / 0 RB Offset
		18625 to 19175	18625, 18900, 19175	5 MHz	QPSK, 16QAM, 64QAM	1 RB / 0 RB Offset
		18650 to 19150	18650, 18900, 19150	10 MHz	QPSK, 16QAM, 64QAM	1 RB / 0 RB Offset
		18675 to 19125	18675, 18900, 19125	15 MHz	QPSK, 16QAM, 64QAM	1 RB / 0 RB Offset
		18700 to 19100	18700, 18900, 19100	20 MHz	QPSK, 16QAM, 64QAM	1 RB / 0 RB Offset
-	Frequency Stability	18607 to 19193	18607, 19193	1.4 MHz	QPSK	1 RB / 0 RB Offset
		18615 to 19185	18615, 19185	3 MHz	QPSK	1 RB / 0 RB Offset
		18625 to 19175	18625, 19175	5 MHz	QPSK	1 RB / 0 RB Offset
		18650 to 19150	18650, 19150	10 MHz	QPSK	1 RB / 0 RB Offset
		18675 to 19125	18675, 19125	15 MHz	QPSK	1 RB / 0 RB Offset
		18700 to 19100	18700, 19100	20 MHz	QPSK	1 RB / 0 RB Offset
-	Occupied Bandwidth	18607 to 19193	18607, 18900, 19193	1.4 MHz	QPSK, 16QAM, 64QAM	6 RB / 0 RB Offset
		18615 to 19185	18615, 18900, 19185	3 MHz	QPSK, 16QAM, 64QAM	15 RB / 0 RB Offset
		18625 to 19175	18625, 18900, 19175	5 MHz	QPSK, 16QAM, 64QAM	25 RB / 0 RB Offset
		18650 to 19150	18650, 18900, 19150	10 MHz	QPSK, 16QAM, 64QAM	50 RB / 0 RB Offset
		18675 to 19125	18675, 18900, 19125	15 MHz	QPSK, 16QAM, 64QAM	75 RB / 0 RB Offset
		18700 to 19100	18700, 18900, 19100	20 MHz	QPSK, 16QAM, 64QAM	100 RB / 0 RB Offset
-	Peak to Average Ratio	18607 to 19193	18607, 18900, 19193	1.4 MHz	QPSK, 16QAM, 64QAM	1 RB / 0 RB Offset
		18615 to 19185	18615, 18900, 19185	3 MHz	QPSK, 16QAM, 64QAM	1 RB / 0 RB Offset
		18625 to 19175	18625, 18900, 19175	5 MHz	QPSK, 16QAM, 64QAM	1 RB / 0 RB Offset
		18650 to 19150	18650, 18900, 19150	10 MHz	QPSK, 16QAM, 64QAM	1 RB / 0 RB Offset
		18675 to 19125	18675, 18900, 19125	15 MHz	QPSK, 16QAM, 64QAM	1 RB / 0 RB Offset
		18700 to 19100	18700, 18900, 19100	20 MHz	QPSK, 16QAM, 64QAM	1 RB / 0 RB Offset

EUT Configure Mode	Test Item	Available Channel	Tested Channel	Channel Bandwidth	Modulation	Mode		
-	Band Edge	18607 to 19193	18607	1.4 MHz	QPSK	1 RB / 0 RB Offset 6 RB / 0 RB Offset		
			19193	1.4 MHz	QPSK	1 RB / 5 RB Offset 6 RB / 0 RB Offset		
		18615 to 19185	18615	3 MHz	QPSK	1 RB / 0 RB Offset 15 RB / 0 RB Offset		
			19185	3 MHz	QPSK	1 RB / 14 RB Offset 15 RB / 0 RB Offset		
		18625 to 19175	18625	5 MHz	QPSK	1 RB / 0 RB Offset 25 RB / 0 RB Offset		
			19175	5 MHz	QPSK	1 RB / 24 RB Offset 25 RB / 0 RB Offset		
		18650 to 19150	18650	10 MHz	QPSK	1 RB / 0 RB Offset 50 RB / 0 RB Offset		
			19150	10 MHz	QPSK	1 RB / 49 RB Offset 50 RB / 0 RB Offset		
		18675 to 19125	18675	15 MHz	QPSK	1 RB / 0 RB Offset 75 RB / 0 RB Offset		
			19125	15 MHz	QPSK	1 RB / 74 RB Offset 75 RB / 0 RB Offset		
		18700 to 19100	18700	20 MHz	QPSK	1 RB / 0 RB Offset 100 RB / 0 RB Offset		
			19100	20 MHz	QPSK	1 RB / 99 RB Offset 100 RB / 0 RB Offset		
		-	Conducted Spurious Emission	18607 to 19193	18607, 18900, 19193	1.4 MHz	QPSK	1 RB / 0 RB Offset
				18615 to 19185	18615, 18900, 19185	3 MHz	QPSK	1 RB / 0 RB Offset
				18625 to 19175	18625, 18900, 19175	5 MHz	QPSK	1 RB / 0 RB Offset
				18650 to 19150	18650, 18900, 19150	10 MHz	QPSK	1 RB / 0 RB Offset
				18675 to 19125	18675, 18900, 19125	15 MHz	QPSK	1 RB / 0 RB Offset
				18700 to 19100	18700, 18900, 19100	20 MHz	QPSK	1 RB / 0 RB Offset
-	Radiated Emission	18700 to 19100	18700, 18900, 19100	20 MHz	QPSK	1 RB / 0 RB Offset		

Note: This device was tested under all bandwidths, RB configurations and modulations. The worst case was found in QPSK modulation.

Test Condition:

Test Item	Environmental Conditions	Input Power	Tested By
EIRP	26 deg. C, 58 % RH	3.85 Vdc	Karl Lee
Frequency Stability	26 deg. C, 58 % RH	3.85 Vdc	Gavin Wu
Occupied Bandwidth	26 deg. C, 58 % RH	3.85 Vdc	Gavin Wu
Band Edge	26 deg. C, 58 % RH	3.85 Vdc	Gavin Wu
Peak to Average Ratio	26 deg. C, 58 % RH	3.85 Vdc	Gavin Wu
Conducted Spurious Emission	26 deg. C, 58 % RH	3.85 Vdc	Gavin Wu
Radiated Emission	25 deg. C, 65 % RH	120 Vac, 60 Hz	Karl Lee

3.4 EUT Operating Conditions

The EUT makes a call to the communication simulator. The communication simulator station system controlled a EUT to export maximum output power under transmission mode and specific channel frequency

3.5 General Description of Applied Standards

The EUT is a RF Product. According to the specifications of the manufacturer, it must comply with the requirements of the following standards:

FCC 47 CFR Part 2

FCC 47 CFR Part 24

KDB 971168 D01 Power Meas License Digital Systems v02r02

ANSI/TIA/EIA-603-E 2016

ANSI 63.26-2015

NOTE: All test items have been performed and recorded as per the above standards.

4 Test Types and Results

4.1 Output Power Measurement

4.1.1 Limits of Output Power Measurement

Mobile / Portable station are limited to 2 watts e.i.r.p.

4.1.2 Test Procedures

EIRP / ERP Measurement:

- a. All measurements were done at low, middle and high operational frequency range. RBW and VBW is 1 MHz for GSM, GPRS & EDGE, 5 MHz for WCDMA, and 10 MHz for LTE mode.
- b. Substitution method is used for E.I.R.P measurement. In the semi-anechoic chamber, EUT placed on the 0.8 m (below or equal 1 GHz) and/or 1.5 m (above 1 GHz) height of Turn Table, rotated the table around 360 degrees to search the maximum radiation power and receiver antenna shall be rotated vertical and horizontal polarization and moved height from 1 m to 4 m to find the maximum polar radiated power. The "Read Value" is the spectrum reading the maximum power value.
- c. The substitution horn antenna is substituted for EUT at the same position and signals generator export the CW signal to the substitution antenna via a tx cable. Rotated the Turn Table and moved receiving antenna to find the maximum radiation power. Adjust output power level of S.G to get a Value of spectrum reading equal to "Read Value" of step b. Record the power level of S.G.
- d. $EIRP = \text{Output power level of S.G} - \text{TX cable loss} + \text{Antenna gain of substitution horn}$. E.R.P power can be calculated form E.I.R.P power by subtracting the gain of dipole, $E.R.P \text{ power} = E.I.P.R \text{ power} - 2.15 \text{ dBi}$.

Conducted Power Measurement:

The EUT was set up for the maximum power with GSM, GPRS, EDGE, WCDMA, and LTE link data modulation and link up with simulator. Set the EUT to transmit under low, middle and high channel and record the power level shown on simulator.

4.1.3 Test Setup

EIRP / ERP Measurement:

<Radiated Emission below or equal 1 GHz>

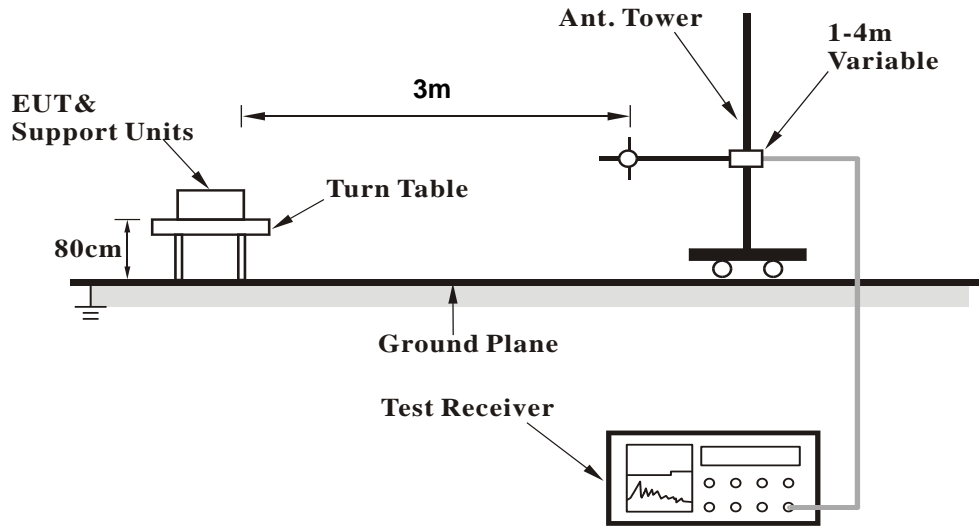

<Radiated Emission above 1 GHz>

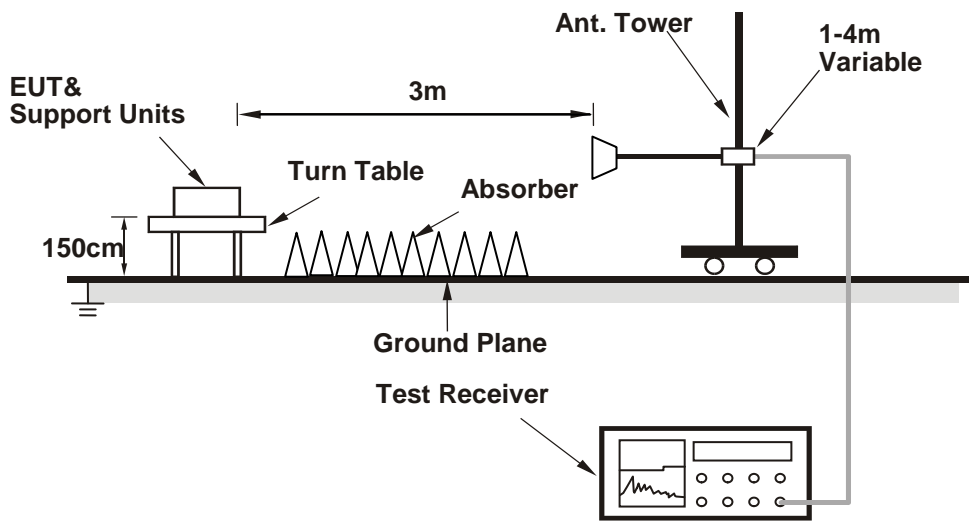

For the actual test configuration, please refer to the attached file (Test Setup Photo).

Conducted Power Measurement:

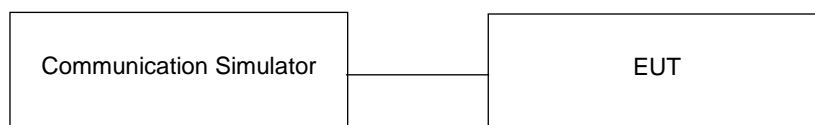

4.1.4 Test Results

Conducted Output Power (dBm)

Band	GSM1900		
	512	661	810
Channel			
Frequency (MHz)	1850.2	1880.0	1909.8
GSM (GMSK, 1Tx-slot)	29.24	29.27	29.14
GPRS (GMSK, 1Tx-slot)	29.21	29.24	29.11
GPRS (GMSK, 2Tx-slot)	27.92	27.95	27.82
GPRS (GMSK, 3Tx-slot)	27.02	27.05	26.92
GPRS (GMSK, 4Tx-slot)	25.65	25.68	25.55
EDGE (8PSK, 1Tx-slot)	25.04	25.07	24.94
EDGE (8PSK, 2Tx-slot)	24.32	24.35	24.22
EDGE (8PSK, 3Tx-slot)	23.08	23.11	22.98
EDGE (8PSK, 4Tx-slot)	21.77	21.80	21.67
DTM (GMSK, 2Tx-slot)	27.98	28.01	27.88
DTM (GMSK, 3Tx-slot)	27.00	27.03	26.90
DTM (8PSK, 2Tx-slot)	23.89	23.92	23.79
DTM (8PSK, 3Tx-slot)	23.05	23.08	22.95

Band	WCDMA II		
	9262	9400	9538
Channel			
Frequency (MHz)	1852.4	1880.0	1907.6
RMC 12.2K	23.60	23.68	23.71
HSDPA Subtest-1	22.55	22.67	22.76
HSDPA Subtest-2	22.53	22.65	22.71
HSDPA Subtest-3	22.14	22.23	22.29
HSDPA Subtest-4	22.04	22.21	22.23
DC-HSDPA Subtest-1	22.52	22.66	22.74
DC-HSDPA Subtest-2	22.50	22.63	22.71
DC-HSDPA Subtest-3	22.10	22.20	22.30
DC-HSDPA Subtest-4	22.08	22.18	22.24
HSUPA Subtest-1	22.48	22.70	22.72
HSUPA Subtest-2	20.41	20.79	20.62
HSUPA Subtest-3	21.88	22.23	22.01
HSUPA Subtest-4	20.42	20.52	20.59
HSUPA Subtest-5	22.57	22.70	22.65

LTE Band 2

BW	MCS Index	RB Size	RB Offset	Low	Mid	High	3GPP MPR (dB)	BW	MCS Index	RB Size	RB Offset	Low	Mid	High	3GPP MPR (dB)
				18700	18900	19100						18675	18900	19125	
				Channel Frequency (MHz)	1860.0	1880.0						1900.0	Channel Frequency (MHz)	1857.5	
20M	QPSK	1	0	24.44	24.48	24.39	0	15M	QPSK	1	0	24.38	24.42	24.33	0
		1	50	24.32	24.42	24.25	0			1	37	24.26	24.36	24.19	0
		1	99	24.30	24.32	24.24	0			1	74	24.24	24.26	24.18	0
		50	0	23.38	23.44	23.35	1			36	0	23.32	23.38	23.29	1
		50	25	23.33	23.40	23.31	1			36	19	23.27	23.34	23.25	1
		50	50	23.36	23.42	23.33	1			36	39	23.30	23.36	23.27	1
	100	0	23.33	23.36	23.32	1	75		0	23.27	23.30	23.26	1		
	16QAM	1	0	23.42	23.46	23.37	1		16QAM	1	0	23.36	23.40	23.31	1
		1	50	23.30	23.40	23.23	1			1	37	23.24	23.34	23.17	1
		1	99	23.28	23.30	23.22	1			1	74	23.22	23.24	23.16	1
		50	0	22.36	22.42	22.33	2			36	0	22.30	22.36	22.27	2
		50	25	22.31	22.38	22.29	2			36	19	22.25	22.32	22.23	2
		50	50	22.34	22.40	22.31	2			36	39	22.28	22.34	22.25	2
	100	0	22.31	22.34	22.30	2	75		0	22.25	22.28	22.24	2		
	64QAM	1	0	22.43	22.47	22.38	2		64QAM	1	0	22.37	22.41	22.32	2
		1	50	22.31	22.41	22.24	2			1	37	22.25	22.35	22.18	2
		1	99	22.29	22.31	22.23	2			1	74	22.23	22.25	22.17	2
		50	0	21.37	21.43	21.34	3			36	0	21.31	21.37	21.28	3
50		25	21.32	21.39	21.30	3	36	19		21.26	21.33	21.24	3		
50		50	21.35	21.41	21.32	3	36	39		21.29	21.35	21.26	3		
100	0	21.32	21.35	21.31	3	75	0	21.26	21.29	21.25	3				
10M	QPSK	1	0	24.30	24.34	24.25	0	5M	QPSK	1	0	24.25	24.29	24.20	0
		1	24	24.18	24.28	24.11	0			1	12	24.13	24.23	24.06	0
		1	49	24.16	24.18	24.10	0			1	24	24.11	24.13	24.05	0
		25	0	23.24	23.30	23.21	1			12	0	23.19	23.25	23.16	1
		25	12	23.19	23.26	23.17	1			12	6	23.14	23.21	23.12	1
		25	25	23.22	23.28	23.19	1			12	13	23.17	23.23	23.14	1
	50	0	23.19	23.22	23.18	1	25		0	23.14	23.17	23.13	1		
	16QAM	1	0	23.28	23.32	23.23	1		16QAM	1	0	23.23	23.27	23.18	1
		1	24	23.16	23.26	23.09	1			1	12	23.11	23.21	23.04	1
		1	49	23.14	23.16	23.08	1			1	24	23.09	23.11	23.03	1
		25	0	22.22	22.28	22.19	2			12	0	22.17	22.23	22.14	2
		25	12	22.17	22.24	22.15	2			12	6	22.12	22.19	22.10	2
		25	25	22.20	22.26	22.17	2			12	13	22.15	22.21	22.12	2
	50	0	22.17	22.20	22.16	2	25		0	22.12	22.15	22.11	2		
	64QAM	1	0	22.29	22.33	22.24	2		64QAM	1	0	22.24	22.28	22.19	2
		1	24	22.17	22.27	22.10	2			1	12	22.12	22.22	22.05	2
		1	49	22.15	22.17	22.09	2			1	24	22.10	22.12	22.04	2
		25	0	21.23	21.29	21.20	3			12	0	21.18	21.24	21.15	3
25		12	21.18	21.25	21.16	3	12	6		21.13	21.20	21.11	3		
25		25	21.21	21.27	21.18	3	12	13		21.16	21.22	21.13	3		
50	0	21.18	21.21	21.17	3	25	0	21.13	21.16	21.12	3				
3M	QPSK	1	0	24.18	24.22	24.13	0	1.4M	QPSK	1	0	24.15	24.19	24.10	0
		1	7	24.06	24.16	23.99	0			1	2	24.03	24.13	23.96	0
		1	14	24.04	24.06	23.98	0			1	5	24.01	24.03	23.95	0
		8	0	23.12	23.18	23.09	1			3	0	23.59	23.65	23.56	0
		8	3	23.07	23.14	23.05	1			3	1	23.54	23.61	23.52	0
		8	7	23.10	23.16	23.07	1			3	3	23.57	23.63	23.54	0
	15	0	23.07	23.10	23.06	1	6		0	23.04	23.07	23.03	1		
	16QAM	1	0	23.16	23.20	23.11	1		16QAM	1	0	23.13	23.17	23.08	1
		1	7	23.04	23.14	22.97	1			1	2	23.01	23.11	22.94	1
		1	14	23.02	23.04	22.96	1			1	5	22.99	23.01	22.93	1
		8	0	22.10	22.16	22.07	2			3	0	22.87	22.93	22.84	1
		8	3	22.05	22.12	22.03	2			3	1	22.82	22.89	22.80	1
		8	7	22.08	22.14	22.05	2			3	3	22.85	22.91	22.82	1
	15	0	22.05	22.08	22.04	2	6		0	22.02	22.05	22.01	2		
	64QAM	1	0	22.17	22.21	22.12	2		64QAM	1	0	22.14	22.18	22.09	2
		1	7	22.05	22.15	21.98	2			1	2	22.02	22.12	21.95	2
		1	14	22.03	22.05	21.97	2			1	5	22.00	22.02	21.94	2
		8	0	21.11	21.17	21.08	3			3	0	21.88	21.94	21.85	2
8		3	21.06	21.13	21.04	3	3	1		21.83	21.90	21.81	2		
8		7	21.09	21.15	21.06	3	3	3		21.86	21.92	21.83	2		
15	0	21.06	21.09	21.05	3	6	0	21.03	21.06	21.02	3				

EIRP Power (dBm)

GSM							
Plane	Channel	Frequency (MHz)	LVL (dBm)	Correction Factor (dB)	EIRP (dBm)	EIRP (mW)	Polarization (H/V)
X	512	1850.2	-11.60	38.19	26.59	456.04	H
	661	1880.0	-12.14	38.70	26.56	452.90	
	810	1909.8	-12.83	39.35	26.52	448.75	
	512	1850.2	-16.90	38.48	21.58	143.88	V
	661	1880.0	-17.04	38.59	21.55	142.89	
	810	1909.8	-17.33	38.87	21.54	142.56	

EDGE							
Plane	Channel	Frequency (MHz)	LVL (dBm)	Correction Factor (dB)	EIRP (dBm)	EIRP (mW)	Polarization (H/V)
X	512	1850.2	-15.70	38.19	22.49	177.42	H
	661	1880.0	-16.24	38.70	22.46	176.20	
	810	1909.8	-16.73	39.35	22.62	182.81	
	512	1850.2	-20.96	38.48	17.52	56.49	V
	661	1880.0	-21.04	38.59	17.55	56.89	
	810	1909.8	-21.34	38.87	17.53	56.62	

WCDMA							
Plane	Channel	Frequency (MHz)	LVL (dBm)	Correction Factor (dB)	EIRP (dBm)	EIRP (mW)	Polarization (H/V)
X	9262	1852.4	-16.67	38.19	21.52	141.91	H
	9400	1880.0	-17.16	38.70	21.54	142.56	
	9538	1907.6	-17.82	39.35	21.53	142.23	
	9262	1852.4	-21.94	38.48	16.54	45.08	V
	9400	1880.0	-22.08	38.59	16.51	44.77	
	9538	1907.6	-22.40	38.87	16.47	44.36	

LTE Band 2							
Channel Bandwidth: 1.4 MHz / QPSK							
Plane	Channel	Frequency (MHz)	LVL (dBm)	Correction Factor (dB)	EIRP (dBm)	EIRP (mW)	Polarization (H/V)
X	18607	1850.7	-22.64	44.70	22.06	160.69	H
	18900	1880.0	-22.60	44.70	22.10	162.18	
	19193	1909.3	-22.57	44.57	22.00	158.60	
	18607	1850.7	-27.26	44.27	17.01	50.23	V
	18900	1880.0	-27.80	44.87	17.07	50.93	
	19193	1909.3	-27.54	44.61	17.07	50.97	
Channel Bandwidth: 1.4 MHz / 16QAM							
X	18607	1850.7	-23.67	44.70	21.03	126.77	H
	18900	1880.0	-23.64	44.70	21.06	127.64	
	19193	1909.3	-23.52	44.57	21.05	127.44	
	18607	1850.7	-28.23	44.27	16.04	40.18	V
	18900	1880.0	-28.84	44.87	16.03	40.09	
	19193	1909.3	-28.56	44.61	16.05	40.30	
Channel Bandwidth: 1.4 MHz / 64QAM							
X	18607	1850.7	-24.66	44.70	20.04	100.93	H
	18900	1880.0	-24.63	44.70	20.07	101.62	
	19193	1909.3	-24.54	44.57	20.03	100.76	
	18607	1850.7	-29.27	44.27	15.00	31.62	V
	18900	1880.0	-29.80	44.87	15.07	32.14	
	19193	1909.3	-29.53	44.61	15.08	32.23	

LTE Band 2							
Channel Bandwidth: 3 MHz / QPSK							
Plane	Channel	Frequency (MHz)	LVL (dBm)	Correction Factor (dB)	EIRP (dBm)	EIRP (mW)	Polarization (H/V)
X	18615	1851.5	-22.69	44.70	22.01	158.85	H
	18900	1880.0	-22.64	44.70	22.06	160.69	
	19185	1908.5	-22.50	44.57	22.07	161.18	
	18615	1851.5	-27.22	44.27	17.05	50.70	V
	18900	1880.0	-27.86	44.87	17.01	50.23	
	19185	1908.5	-27.57	44.61	17.04	50.62	
Channel Bandwidth: 3 MHz / 16QAM							
X	18615	1851.5	-23.67	44.70	21.03	126.77	H
	18900	1880.0	-23.66	44.70	21.04	127.06	
	19185	1908.5	-23.57	44.57	21.00	125.98	
	18615	1851.5	-28.23	44.27	16.04	40.18	V
	18900	1880.0	-28.84	44.87	16.03	40.09	
	19185	1908.5	-28.59	44.61	16.02	40.02	
Channel Bandwidth: 3 MHz / 64QAM							
X	18615	1851.5	-24.63	44.70	20.07	101.62	H
	18900	1880.0	-24.64	44.70	20.06	101.39	
	19185	1908.5	-24.55	44.57	20.02	100.53	
	18615	1851.5	-29.24	44.27	15.03	31.84	V
	18900	1880.0	-29.86	44.87	15.01	31.70	
	19185	1908.5	-29.57	44.61	15.04	31.94	

LTE Band 2							
Channel Bandwidth: 5 MHz / QPSK							
Plane	Channel	Frequency (MHz)	LVL (dBm)	Correction Factor (dB)	EIRP (dBm)	EIRP (mW)	Polarization (H/V)
X	18625	1852.5	-22.66	44.70	22.04	159.96	H
	18900	1880.0	-22.67	44.70	22.03	159.59	
	19175	1907.5	-22.53	44.57	22.04	160.07	
	18625	1852.5	-27.24	44.27	17.03	50.47	V
	18900	1880.0	-27.80	44.87	17.07	50.93	
	19175	1907.5	-27.58	44.61	17.03	50.50	
Channel Bandwidth: 5 MHz / 16QAM							
X	18625	1852.5	-23.63	44.70	21.07	127.94	H
	18900	1880.0	-23.65	44.70	21.05	127.35	
	19175	1907.5	-23.50	44.57	21.07	128.03	
	18625	1852.5	-28.24	44.27	16.03	40.09	V
	18900	1880.0	-28.83	44.87	16.04	40.18	
	19175	1907.5	-28.57	44.61	16.04	40.21	
Channel Bandwidth: 5 MHz / 64QAM							
X	18625	1852.5	-24.67	44.70	20.03	100.69	H
	18900	1880.0	-24.63	44.70	20.07	101.62	
	19175	1907.5	-24.54	44.57	20.03	100.76	
	18625	1852.5	-29.27	44.27	15.00	31.62	V
	18900	1880.0	-29.80	44.87	15.07	32.14	
	19175	1907.5	-29.56	44.61	15.05	32.01	

LTE Band 2							
Channel Bandwidth: 10 MHz / QPSK							
Plane	Channel	Frequency (MHz)	LVL (dBm)	Correction Factor (dB)	EIRP (dBm)	EIRP (mW)	Polarization (H/V)
X	18650	1855.0	-22.62	44.70	22.08	161.44	H
	18900	1880.0	-22.68	44.70	22.02	159.22	
	19150	1905.0	-22.56	44.57	22.01	158.96	
	18650	1855.0	-27.20	44.27	17.07	50.93	V
	18900	1880.0	-27.84	44.87	17.03	50.47	
	19150	1905.0	-27.59	44.61	17.02	50.38	
Channel Bandwidth: 10 MHz / 16QAM							
X	18650	1855.0	-23.63	44.70	21.07	127.94	H
	18900	1880.0	-23.67	44.70	21.03	126.77	
	19150	1905.0	-23.54	44.57	21.03	126.85	
	18650	1855.0	-28.26	44.27	16.01	39.90	V
	18900	1880.0	-28.87	44.87	16.00	39.81	
	19150	1905.0	-28.53	44.61	16.08	40.58	
Channel Bandwidth: 10 MHz / 64QAM							
X	18650	1855.0	-24.63	44.70	20.07	101.62	H
	18900	1880.0	-24.68	44.70	20.02	100.46	
	19150	1905.0	-24.57	44.57	20.00	100.07	
	18650	1855.0	-29.21	44.27	15.06	32.06	V
	18900	1880.0	-29.83	44.87	15.04	31.92	
	19150	1905.0	-29.57	44.61	15.04	31.94	

LTE Band 2							
Channel Bandwidth: 15 MHz / QPSK							
Plane	Channel	Frequency (MHz)	LVL (dBm)	Correction Factor (dB)	EIRP (dBm)	EIRP (mW)	Polarization (H/V)
X	18675	1857.5	-22.64	44.70	22.06	160.69	H
	18900	1880.0	-22.66	44.70	22.04	159.96	
	19125	1902.5	-22.57	44.57	22.00	158.60	
	18675	1857.5	-27.20	44.27	17.07	50.93	V
	18900	1880.0	-27.79	44.87	17.08	51.05	
	19125	1902.5	-27.54	44.61	17.07	50.97	
Channel Bandwidth: 15 MHz / 16QAM							
X	18675	1857.5	-23.66	44.70	21.04	127.06	H
	18900	1880.0	-23.65	44.70	21.05	127.35	
	19125	1902.5	-23.51	44.57	21.06	127.73	
	18675	1857.5	-28.25	44.27	16.02	39.99	V
	18900	1880.0	-28.86	44.87	16.01	39.90	
	19125	1902.5	-28.57	44.61	16.04	40.21	
Channel Bandwidth: 15 MHz / 64QAM							
X	18675	1857.5	-24.63	44.70	20.07	101.62	H
	18900	1880.0	-24.68	44.70	20.02	100.46	
	19125	1902.5	-24.57	44.57	20.00	100.07	
	18675	1857.5	-29.23	44.27	15.04	31.92	V
	18900	1880.0	-29.85	44.87	15.02	31.77	
	19125	1902.5	-29.54	44.61	15.07	32.16	

LTE Band 2							
Channel Bandwidth: 20 MHz / QPSK							
Plane	Channel	Frequency (MHz)	LVL (dBm)	Correction Factor (dB)	EIRP (dBm)	EIRP (mW)	Polarization (H/V)
X	18700	1860.0	-22.53	44.70	22.17	164.82	H
	18900	1880.0	-22.67	44.70	22.03	159.59	
	19100	1900.0	-22.54	44.57	22.03	159.70	
	18700	1860.0	-27.09	44.27	17.18	52.24	V
	18900	1880.0	-27.84	44.87	17.03	50.47	
	19100	1900.0	-27.53	44.61	17.08	51.09	
Channel Bandwidth: 20 MHz / 16QAM							
X	18700	1860.0	-23.54	44.70	21.16	130.62	H
	18900	1880.0	-23.62	44.70	21.08	128.23	
	19100	1900.0	-23.56	44.57	21.01	126.27	
	18700	1860.0	-28.04	44.27	16.23	41.98	V
	18900	1880.0	-28.84	44.87	16.03	40.09	
	19100	1900.0	-28.56	44.61	16.05	40.30	
Channel Bandwidth: 20 MHz / 64QAM							
X	18700	1860.0	-24.53	44.70	20.17	103.99	H
	18900	1880.0	-24.66	44.70	20.04	100.93	
	19100	1900.0	-24.55	44.57	20.02	100.53	
	18700	1860.0	-29.08	44.27	15.19	33.04	V
	18900	1880.0	-29.83	44.87	15.04	31.92	
	19100	1900.0	-29.57	44.61	15.04	31.94	

4.2 Frequency Stability Measurement

4.2.1 Limits of Frequency Stability Measurement

The frequency stability shall be sufficient to ensure that the fundamental emission stays within the authorized frequency block.

4.2.2 Test Procedure

- Device is placed at the oven room. The oven room could control the temperatures and humidity. Power warm up is at least 15 min and power applied should perform before recording frequency error.
- EUT is connected the external power supply to control the DC input power. The test voltage range is from minimum to maximum working voltage. Each step shall be record the frequency error rate.
- The temperature range step is 10 degrees in this test items. All temperature levels shall be hold the ± 0.5 °C during the measurement testing. The each temperature step shall be at least 0.5 hours, consider the EUT could be test under the stability condition.

NOTE: The frequency error was recorded frequency error from the communication simulator.

4.2.3 Test Setup

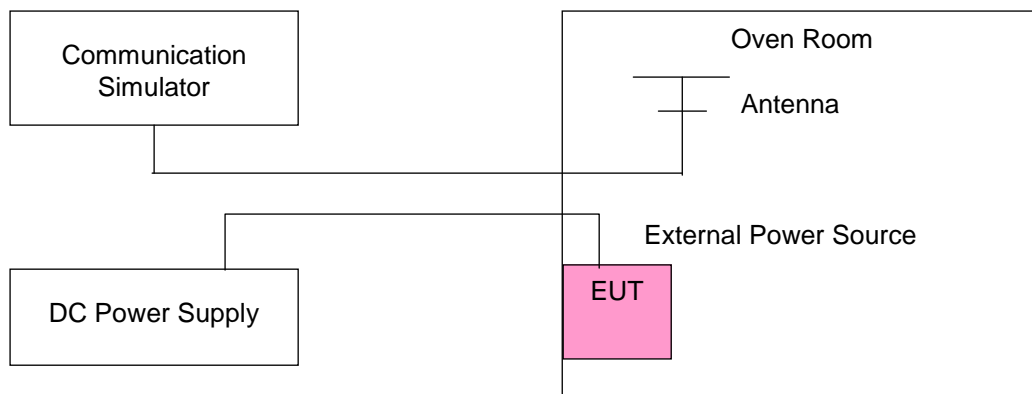

4.2.4 Test Results

Frequency Error vs. Voltage

Voltage (Volts)	GSM				Limit (ppm)
	Low Channel		High Channel		
	Frequency (MHz)	Frequency Error (ppm)	Frequency (MHz)	Frequency Error (ppm)	
3.85	1850.200004	0.002	1909.800003	0.002	2.5
3.6	1850.200003	0.002	1909.800004	0.002	2.5
4.4	1850.200002	0.001	1909.800004	0.002	2.5

Note: The applicant defined the normal working voltage of the battery is from 3.6 Vdc to 4.4 Vdc.

Frequency Error vs. Temperature

Temp. (°C)	GSM				Limit (ppm)
	Low Channel		High Channel		
	Frequency (MHz)	Frequency Error (ppm)	Frequency (MHz)	Frequency Error (ppm)	
-30	1850.200003	0.002	1909.800003	0.002	2.5
-20	1850.200004	0.002	1909.800001	0.001	2.5
-10	1850.200004	0.002	1909.800001	0.001	2.5
0	1850.200003	0.001	1909.800002	0.001	2.5
10	1850.200002	0.001	1909.800002	0.001	2.5
20	1850.199998	-0.001	1909.799997	-0.002	2.5
30	1850.199996	-0.002	1909.799999	-0.001	2.5
40	1850.199997	-0.002	1909.799998	-0.001	2.5
50	1850.199998	-0.001	1909.799996	-0.002	2.5
55	1850.199998	-0.001	1909.799997	-0.002	2.5

Frequency Error vs. Voltage

Voltage (Volts)	EDGE				Limit (ppm)
	Low Channel		High Channel		
	Frequency (MHz)	Frequency Error (ppm)	Frequency (MHz)	Frequency Error (ppm)	
3.85	1850.200003	0.002	1909.800003	0.002	2.5
3.6	1850.200002	0.001	1909.800004	0.002	2.5
4.4	1850.200004	0.002	1909.800004	0.002	2.5

Note: The applicant defined the normal working voltage of the battery is from 3.6 Vdc to 4.4 Vdc.

Frequency Error vs. Temperature

Temp. (°C)	EDGE				Limit (ppm)
	Low Channel		High Channel		
	Frequency (MHz)	Frequency Error (ppm)	Frequency (MHz)	Frequency Error (ppm)	
-30	1850.200003	0.002	1909.800002	0.001	2.5
-20	1850.200003	0.002	1909.800003	0.002	2.5
-10	1850.200001	0.001	1909.800003	0.002	2.5
0	1850.200002	0.001	1909.800003	0.002	2.5
10	1850.200004	0.002	1909.800001	0.001	2.5
20	1850.199997	-0.001	1909.799998	-0.001	2.5
30	1850.199998	-0.001	1909.799998	-0.001	2.5
40	1850.199997	-0.002	1909.799997	-0.002	2.5
50	1850.199999	-0.001	1909.799997	-0.002	2.5
55	1850.199999	-0.001	1909.799997	-0.002	2.5

Frequency Error vs. Voltage

Voltage (Volts)	WCDMA				Limit (ppm)
	Low Channel		High Channel		
	Frequency (MHz)	Frequency Error (ppm)	Frequency (MHz)	Frequency Error (ppm)	
3.85	1852.400003	0.002	1907.600001	0.001	2.5
3.6	1852.400004	0.002	1907.600002	0.001	2.5
4.4	1852.400003	0.002	1907.600002	0.001	2.5

Note: The applicant defined the normal working voltage of the battery is from 3.6 Vdc to 4.4 Vdc.

Frequency Error vs. Temperature

Temp. (°C)	WCDMA				Limit (ppm)
	Low Channel		High Channel		
	Frequency (MHz)	Frequency Error (ppm)	Frequency (MHz)	Frequency Error (ppm)	
-30	1852.400003	0.002	1907.600002	0.001	2.5
-20	1852.400002	0.001	1907.600003	0.002	2.5
-10	1852.400001	0.001	1907.600004	0.002	2.5
0	1852.400001	0.001	1907.600001	0.001	2.5
10	1852.400002	0.001	1907.600001	0.001	2.5
20	1852.399997	-0.002	1907.599996	-0.002	2.5
30	1852.399997	-0.002	1907.599996	-0.002	2.5
40	1852.399998	-0.001	1907.599996	-0.002	2.5
50	1852.399998	-0.001	1907.599996	-0.002	2.5
55	1852.399998	-0.001	1907.599997	-0.001	2.5

Frequency Error vs. Voltage

Voltage (Volts)	LTE Band 2				Limit (ppm)
	Channel Bandwidth: 1.4 MHz				
	Low Channel		High Channel		
	Frequency (MHz)	Frequency Error (ppm)	Frequency (MHz)	Frequency Error (ppm)	
3.85	1850.700004	0.002	1909.300001	0.001	2.5
3.6	1850.700003	0.002	1909.300002	0.001	2.5
4.4	1850.700002	0.001	1909.300004	0.002	2.5

Note: The applicant defined the normal working voltage of the battery is from 3.6 Vdc to 4.4 Vdc.

Frequency Error vs. Temperature

Temp. (°C)	LTE Band 2				Limit (ppm)
	Channel Bandwidth: 1.4 MHz				
	Low Channel		High Channel		
	Frequency (MHz)	Frequency Error (ppm)	Frequency (MHz)	Frequency Error (ppm)	
-30	1850.700002	0.001	1909.300004	0.002	2.5
-20	1850.700001	0.001	1909.300003	0.002	2.5
-10	1850.700002	0.001	1909.300002	0.001	2.5
0	1850.700002	0.001	1909.300004	0.002	2.5
10	1850.700004	0.002	1909.300004	0.002	2.5
20	1850.699998	-0.001	1909.299997	-0.001	2.5
30	1850.699999	-0.001	1909.299998	-0.001	2.5
40	1850.699997	-0.002	1909.299996	-0.002	2.5
50	1850.699997	-0.001	1909.299998	-0.001	2.5
55	1850.699997	-0.002	1909.299997	-0.002	2.5

Frequency Error vs. Voltage

Voltage (Volts)	LTE Band 2				Limit (ppm)
	Channel Bandwidth: 3 MHz				
	Low Channel		High Channel		
	Frequency (MHz)	Frequency Error (ppm)	Frequency (MHz)	Frequency Error (ppm)	
3.85	1851.500001	0.001	1907.500001	0.001	2.5
3.6	1851.500003	0.002	1907.500004	0.002	2.5
4.4	1851.500003	0.002	1907.500003	0.002	2.5

Note: The applicant defined the normal working voltage of the battery is from 3.6 Vdc to 4.4 Vdc.

Frequency Error vs. Temperature

Temp. (°C)	LTE Band 2				Limit (ppm)
	Channel Bandwidth: 3 MHz				
	Low Channel		High Channel		
	Frequency (MHz)	Frequency Error (ppm)	Frequency (MHz)	Frequency Error (ppm)	
-30	1851.500003	0.002	1907.500002	0.001	2.5
-20	1851.500001	0.001	1907.500003	0.001	2.5
-10	1851.500004	0.002	1907.500002	0.001	2.5
0	1851.500004	0.002	1907.500002	0.001	2.5
10	1851.500003	0.002	1907.500002	0.001	2.5
20	1851.499999	-0.001	1907.499998	-0.001	2.5
30	1851.499998	-0.001	1907.499997	-0.002	2.5
40	1851.499998	-0.001	1907.499996	-0.002	2.5
50	1851.499997	-0.002	1907.499997	-0.002	2.5
55	1851.499997	-0.002	1907.499997	-0.002	2.5

Frequency Error vs. Voltage

Voltage (Volts)	LTE Band 2				Limit (ppm)
	Channel Bandwidth: 5 MHz				
	Low Channel		High Channel		
	Frequency (MHz)	Frequency Error (ppm)	Frequency (MHz)	Frequency Error (ppm)	
3.85	1852.500001	0.001	1907.500001	0.001	2.5
3.6	1852.500003	0.002	1907.500004	0.002	2.5
4.4	1852.500003	0.002	1907.500003	0.002	2.5

Note: The applicant defined the normal working voltage of the battery is from 3.6 Vdc to 4.4 Vdc.

Frequency Error vs. Temperature

Temp. (°C)	LTE Band 2				Limit (ppm)
	Channel Bandwidth: 5 MHz				
	Low Channel		High Channel		
	Frequency (MHz)	Frequency Error (ppm)	Frequency (MHz)	Frequency Error (ppm)	
-30	1852.500003	0.002	1907.500003	0.001	2.5
-20	1852.500001	0.001	1907.500002	0.001	2.5
-10	1852.500003	0.001	1907.500002	0.001	2.5
0	1852.500003	0.002	1907.500003	0.002	2.5
10	1852.500003	0.002	1907.500004	0.002	2.5
20	1852.499999	-0.001	1907.499996	-0.002	2.5
30	1852.499999	-0.001	1907.499997	-0.001	2.5
40	1852.499997	-0.002	1907.499997	-0.002	2.5
50	1852.499997	-0.002	1907.499996	-0.002	2.5
55	1852.499999	-0.001	1907.499998	-0.001	2.5

Frequency Error vs. Voltage

Voltage (Volts)	LTE Band 2				Limit (ppm)
	Channel Bandwidth: 10 MHz				
	Low Channel		High Channel		
	Frequency (MHz)	Frequency Error (ppm)	Frequency (MHz)	Frequency Error (ppm)	
3.85	1855.000002	0.001	1905.000002	0.001	2.5
3.6	1855.000004	0.002	1905.000002	0.001	2.5
4.4	1855.000003	0.001	1905.000003	0.002	2.5

Note: The applicant defined the normal working voltage of the battery is from 3.6 Vdc to 4.4 Vdc.

Frequency Error vs. Temperature

Temp. (°C)	LTE Band 2				Limit (ppm)
	Channel Bandwidth: 10 MHz				
	Low Channel		High Channel		
	Frequency (MHz)	Frequency Error (ppm)	Frequency (MHz)	Frequency Error (ppm)	
-30	1855.000003	0.002	1905.000002	0.001	2.5
-20	1855.000004	0.002	1905.000002	0.001	2.5
-10	1855.000001	0.001	1905.000004	0.002	2.5
0	1855.000004	0.002	1905.000003	0.002	2.5
10	1855.000003	0.001	1905.000001	0.001	2.5
20	1854.999998	-0.001	1904.999997	-0.002	2.5
30	1854.999997	-0.002	1904.999999	-0.001	2.5
40	1854.999999	-0.001	1904.999997	-0.001	2.5
50	1854.999998	-0.001	1904.999996	-0.002	2.5
55	1854.999997	-0.002	1904.999999	-0.001	2.5

Frequency Error vs. Voltage

Voltage (Volts)	LTE Band 2				Limit (ppm)
	Channel Bandwidth: 15 MHz				
	Low Channel		High Channel		
	Frequency (MHz)	Frequency Error (ppm)	Frequency (MHz)	Frequency Error (ppm)	
3.85	1857.500002	0.001	1902.500003	0.001	2.5
3.6	1857.500003	0.002	1902.500004	0.002	2.5
4.4	1857.500004	0.002	1902.500002	0.001	2.5

Note: The applicant defined the normal working voltage of the battery is from 3.6 Vdc to 4.4 Vdc.

Frequency Error vs. Temperature

Temp. (°C)	LTE Band 2				Limit (ppm)
	Channel Bandwidth: 15 MHz				
	Low Channel		High Channel		
	Frequency (MHz)	Frequency Error (ppm)	Frequency (MHz)	Frequency Error (ppm)	
-30	1857.500003	0.001	1902.500004	0.002	2.5
-20	1857.500002	0.001	1902.500003	0.002	2.5
-10	1857.500004	0.002	1902.500001	0.001	2.5
0	1857.500003	0.002	1902.500004	0.002	2.5
10	1857.500002	0.001	1902.500004	0.002	2.5
20	1857.499997	-0.002	1902.499998	-0.001	2.5
30	1857.499997	-0.002	1902.499997	-0.001	2.5
40	1857.499996	-0.002	1902.499998	-0.001	2.5
50	1857.499996	-0.002	1902.499996	-0.002	2.5
55	1857.499998	-0.001	1902.499997	-0.001	2.5

Frequency Error vs. Voltage

Voltage (Volts)	LTE Band 2				Limit (ppm)
	Channel Bandwidth: 20 MHz				
	Low Channel		High Channel		
	Frequency (MHz)	Frequency Error (ppm)	Frequency (MHz)	Frequency Error (ppm)	
3.85	1860.000002	0.001	1900.000002	0.001	2.5
3.6	1860.000003	0.002	1900.000004	0.002	2.5
4.4	1860.000003	0.002	1900.000001	0.001	2.5

Note: The applicant defined the normal working voltage of the battery is from 3.6 Vdc to 4.4 Vdc.

Frequency Error vs. Temperature

Temp. (°C)	LTE Band 2				Limit (ppm)
	Channel Bandwidth: 20 MHz				
	Low Channel		High Channel		
	Frequency (MHz)	Frequency Error (ppm)	Frequency (MHz)	Frequency Error (ppm)	
-30	1860.000004	0.002	1900.000004	0.002	2.5
-20	1860.000002	0.001	1900.000002	0.001	2.5
-10	1860.000003	0.001	1900.000003	0.001	2.5
0	1860.000003	0.002	1900.000001	0.001	2.5
10	1860.000002	0.001	1900.000003	0.002	2.5
20	1859.999998	-0.001	1899.999997	-0.002	2.5
30	1859.999997	-0.001	1899.999998	-0.001	2.5
40	1859.999997	-0.002	1899.999998	-0.001	2.5
50	1859.999996	-0.002	1899.999999	-0.001	2.5
55	1859.999996	-0.002	1899.999996	-0.002	2.5

4.3 Occupied Bandwidth Measurement

4.3.1 Test Procedure

The EUT makes a call to the communication simulator. All measurements were done at low, middle and high operational frequency range. The communication simulator station system controlled a EUT to export maximum output power under transmission mode and specific channel frequency. Use OBW measurement function of Spectrum analyzer to measure 99 % occupied bandwidth.

4.3.2 Test Setup

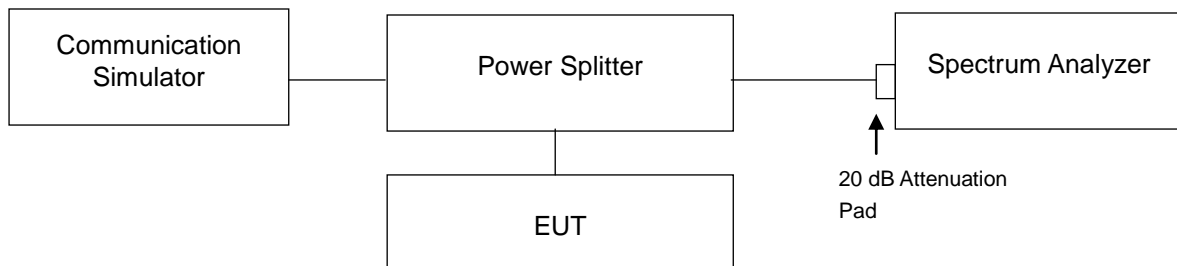

4.3.3 Test Result

Channel	Frequency (MHz)	99 % Occupied Bandwidth (kHz)		Channel	Frequency (MHz)	99 % Occupied Bandwidth (MHz)
		GSM	EDGE			WCDMA
512	1850.2	245.30	246.95	9262	1852.4	4.1397
661	1880.0	245.33	249.50	9400	1880.0	4.5311
810	1909.8	245.99	247.32	9538	1907.6	4.6055

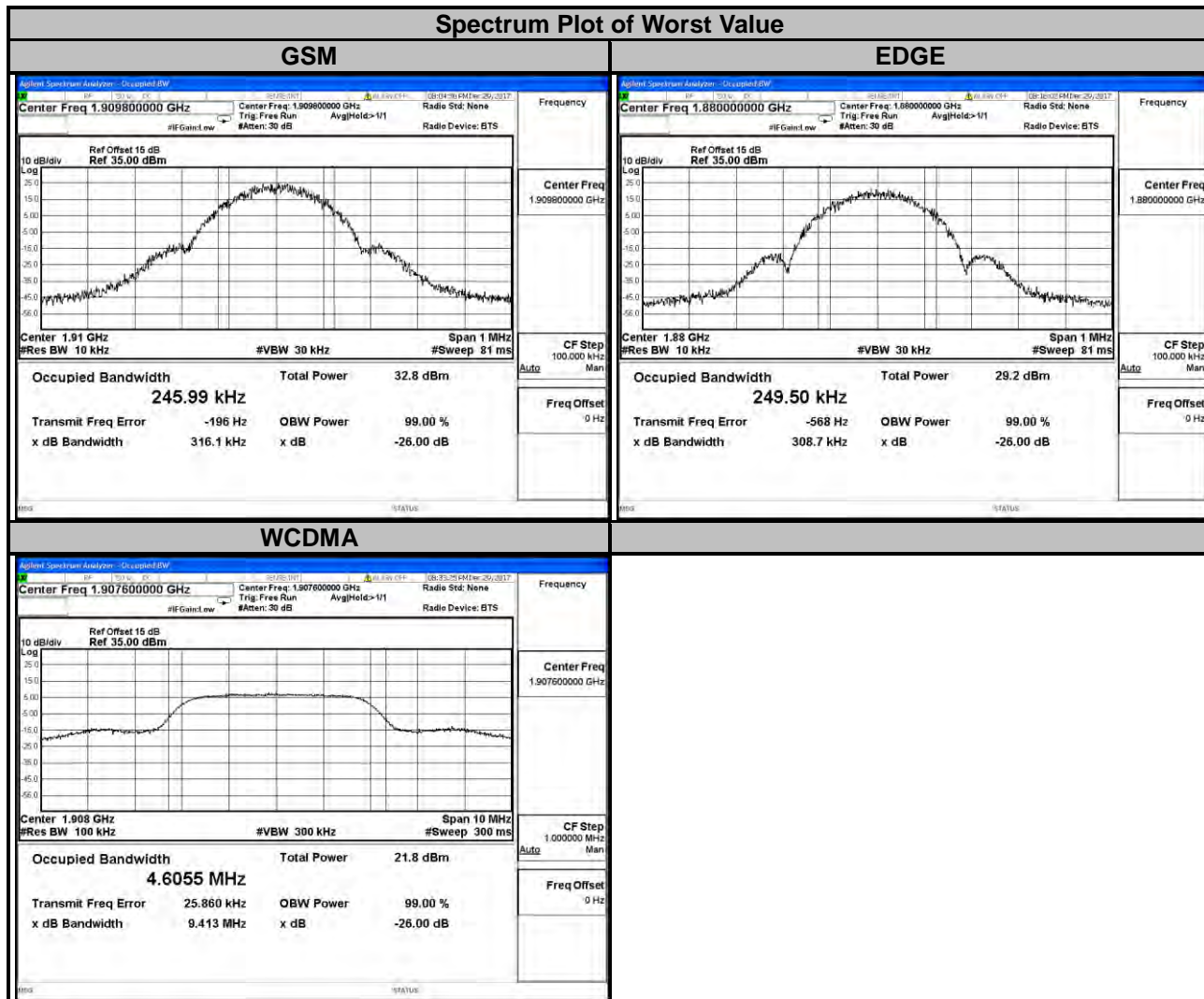

LTE Band 2

Channel Bandwidth: 1.4 MHz					Channel Bandwidth: 3 MHz				
Channel	Frequency (MHz)	99 % Occupied Bandwidth (MHz)			Channel	Frequency (MHz)	99 % Occupied Bandwidth (MHz)		
		QPSK	16QAM	64QAM			QPSK	16QAM	64QAM
18607	1850.7	1.0858	1.0883	1.0863	18615	1851.5	2.6978	2.6937	2.7011
18900	1880.0	1.0865	1.0882	1.0863	18900	1880.0	2.7011	2.6957	2.7036
19193	1909.3	1.0864	1.0895	1.0867	19185	1908.5	2.6982	2.6972	2.7036

Spectrum Plot of Worst Value

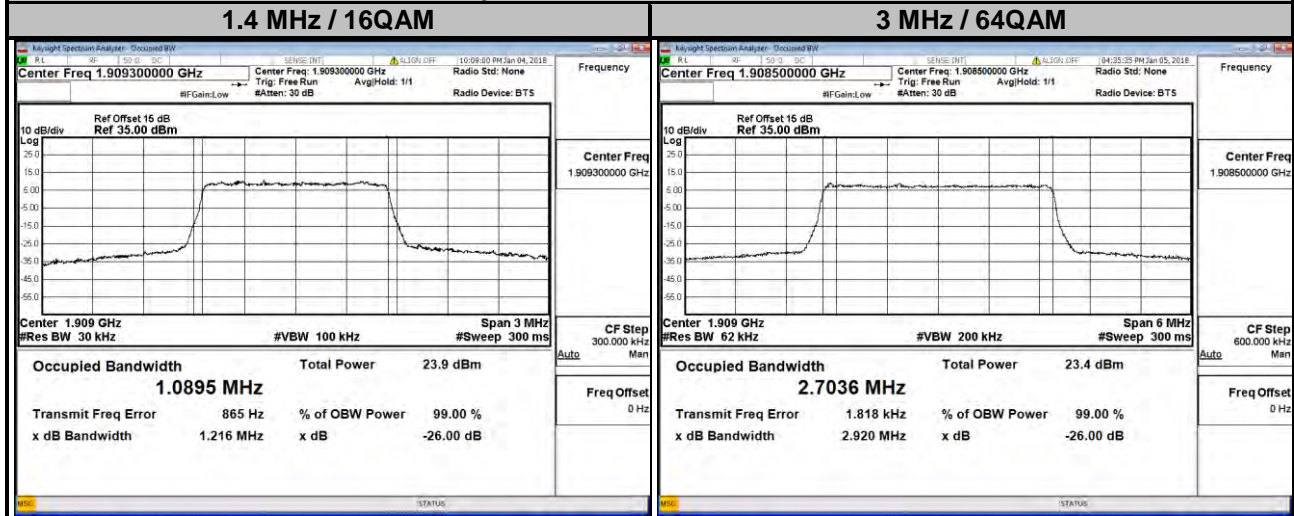

LTE Band 2

Channel Bandwidth: 5 MHz					Channel Bandwidth: 10 MHz				
Channel	Frequency (MHz)	99 % Occupied Bandwidth (MHz)			Channel	Frequency (MHz)	99 % Occupied Bandwidth (MHz)		
		QPSK	16QAM	64QAM			QPSK	16QAM	64QAM
18625	1852.5	4.4871	4.4883	4.4902	18650	1855.0	8.9628	8.9708	8.9607
18900	1880.0	4.4862	4.4865	4.4861	18900	1880.0	8.9608	8.9678	8.9594
19175	1907.5	4.4855	4.4875	4.4860	19150	1905.0	8.9678	8.9711	8.9614

Spectrum Plot of Worst Value

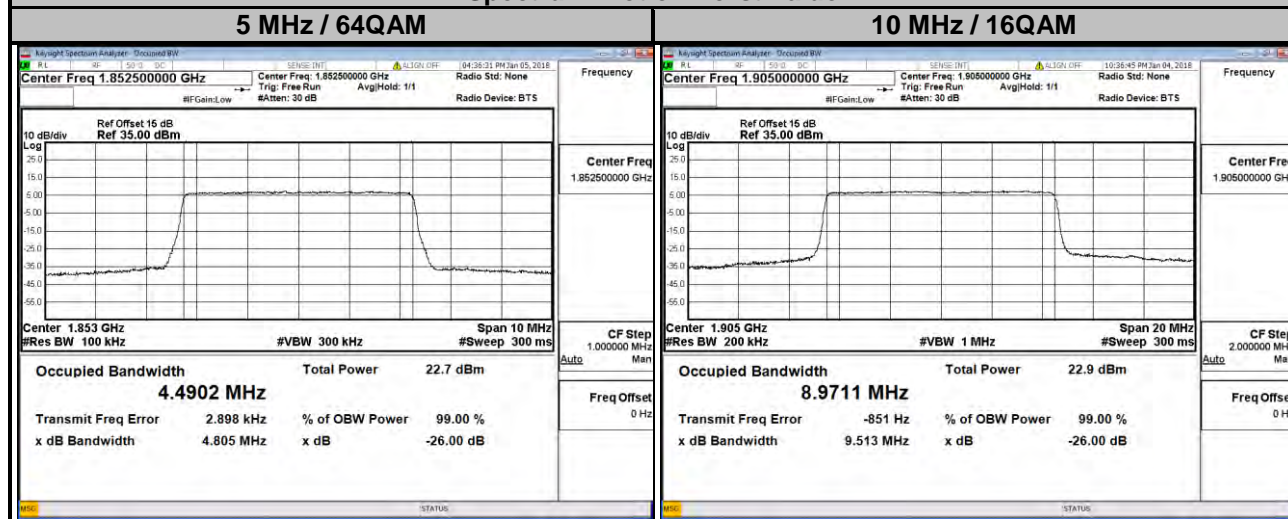

LTE Band 2

Channel Bandwidth: 15 MHz					Channel Bandwidth: 20 MHz				
Channel	Frequency (MHz)	99 % Occupied Bandwidth (MHz)			Channel	Frequency (MHz)	99 % Occupied Bandwidth (MHz)		
		QPSK	16QAM	64QAM			QPSK	16QAM	64QAM
18675	1857.5	13.459	13.454	13.444	18700	1860.0	17.918	17.947	17.946
18900	1880.0	13.452	13.443	13.431	18900	1880.0	17.919	17.935	17.935
19125	1902.5	13.465	13.460	13.445	19100	1900.0	17.950	17.973	17.956

Spectrum Plot of Worst Value

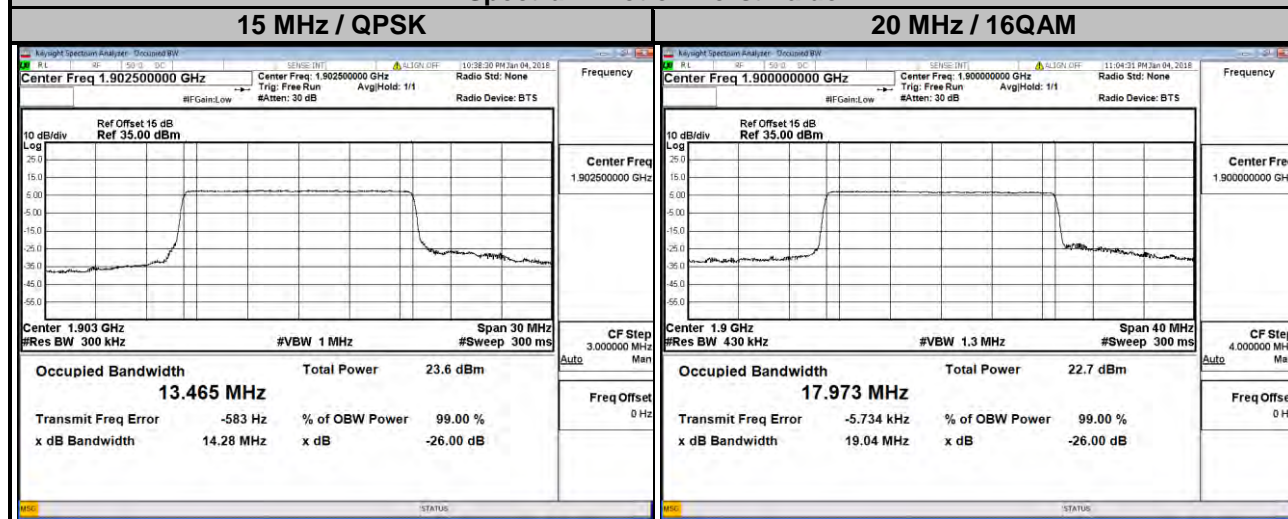

4.4 Band Edge Measurement

4.4.1 Limits of Band Edge Measurement

Power of any emission outside of the authorized operating frequency ranges must be attenuated below the transmitting power (P) by a factor of at least $43 + 10 \log(P)$ dB. In the 1 MHz bands immediately outside and adjacent to the frequency block a resolution bandwidth of at least one percent of the emission bandwidth of the fundamental emission of the transmitter may be employed.

4.4.2 Test Setup

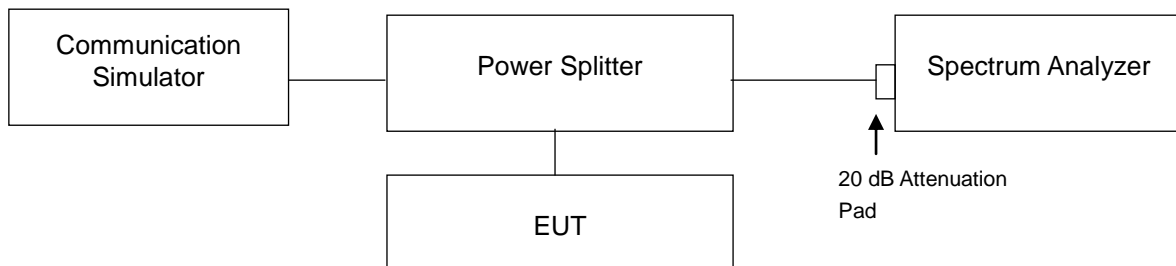

4.4.3 Test Procedures

- All measurements were done at low and high operational frequency range.
- The center frequency of spectrum is the band edge frequency and span is 1 MHz. RB of the spectrum is 10 kHz and VB of the spectrum is 30 kHz (GSM/GPRS/EDGE).
- The center frequency of spectrum is the band edge frequency and span is 5 MHz. RB of the spectrum is 100 kHz and VB of the spectrum is 300 kHz (WCDMA).
- The center frequency of spectrum is the band edge frequency and span is 1 MHz. RB of the spectrum is 13 kHz and VB of the spectrum is 51 kHz (LTE Bandwidth 1.4 MHz).
- The center frequency of spectrum is the band edge frequency and span is 1 MHz. RB of the spectrum is 30 kHz and VB of the spectrum is 100 kHz (LTE Bandwidth 3 MHz).
- The center frequency of spectrum is the band edge frequency and span is 1 MHz. RB of the spectrum is 100 kHz and VB of the spectrum is 300 kHz (LTE Bandwidth 5 MHz/10 MHz).
- The center frequency of spectrum is the band edge frequency and span is 1 MHz. RB of the spectrum is 150 kHz and VB of the spectrum is 470 kHz (LTE Bandwidth 15 MHz).
- The center frequency of spectrum is the band edge frequency and span is 1 MHz. RB of the spectrum is 180 kHz and VB of the spectrum is 560 kHz (LTE Bandwidth 20 MHz).
- Record the max trace plot into the test report.

4.4.4 Test Results

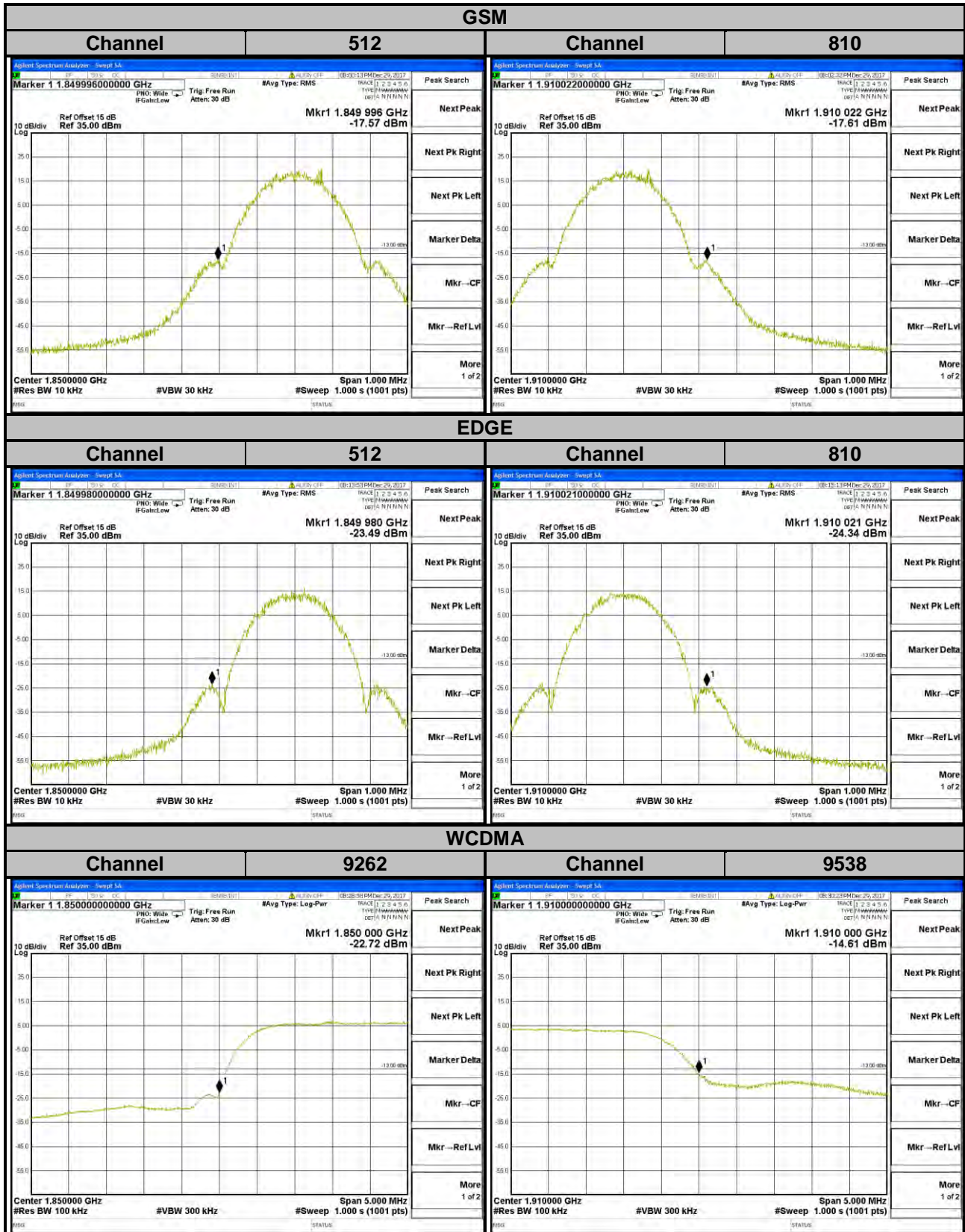

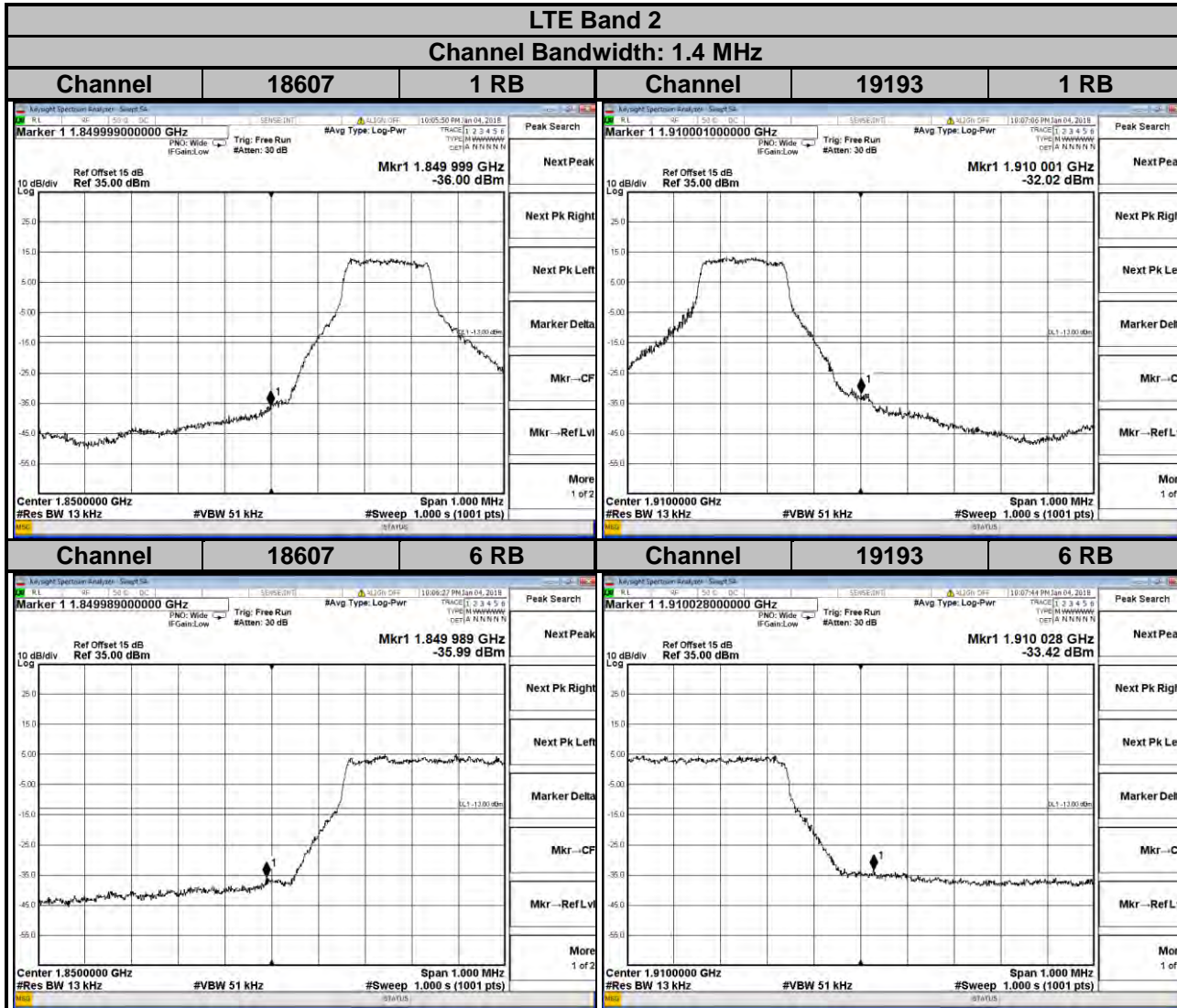

LTE Band 2
Channel Bandwidth: 3 MHz

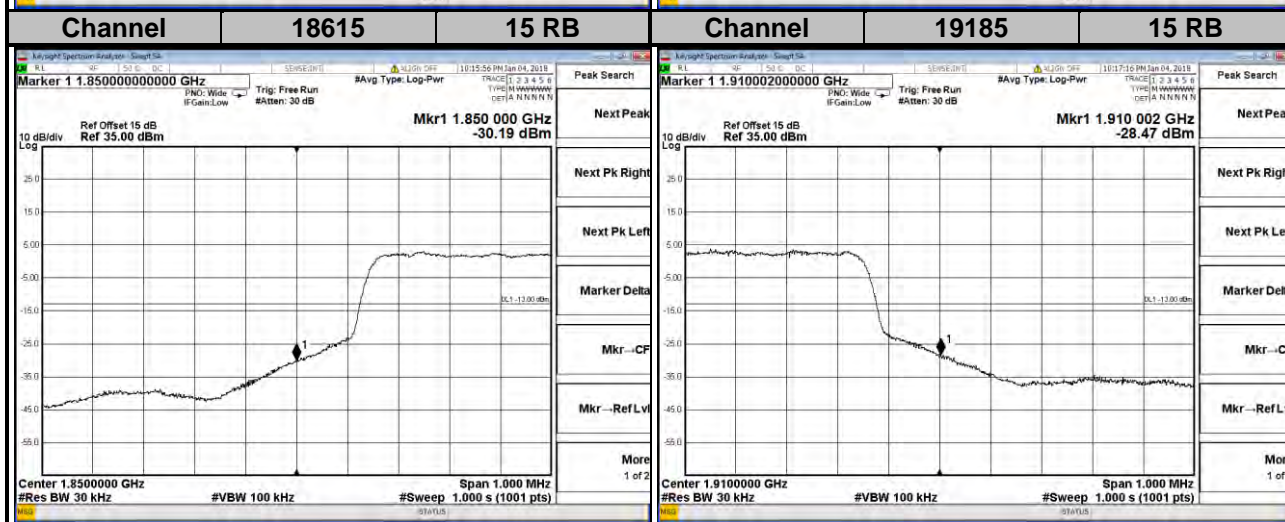
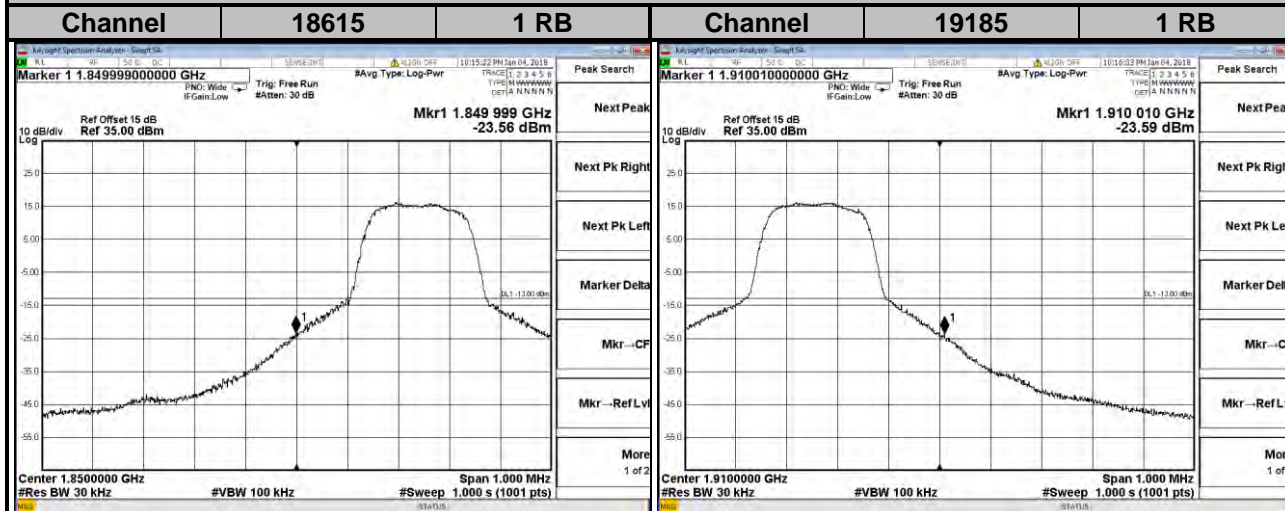

LTE Band 2

Channel Bandwidth: 5 MHz

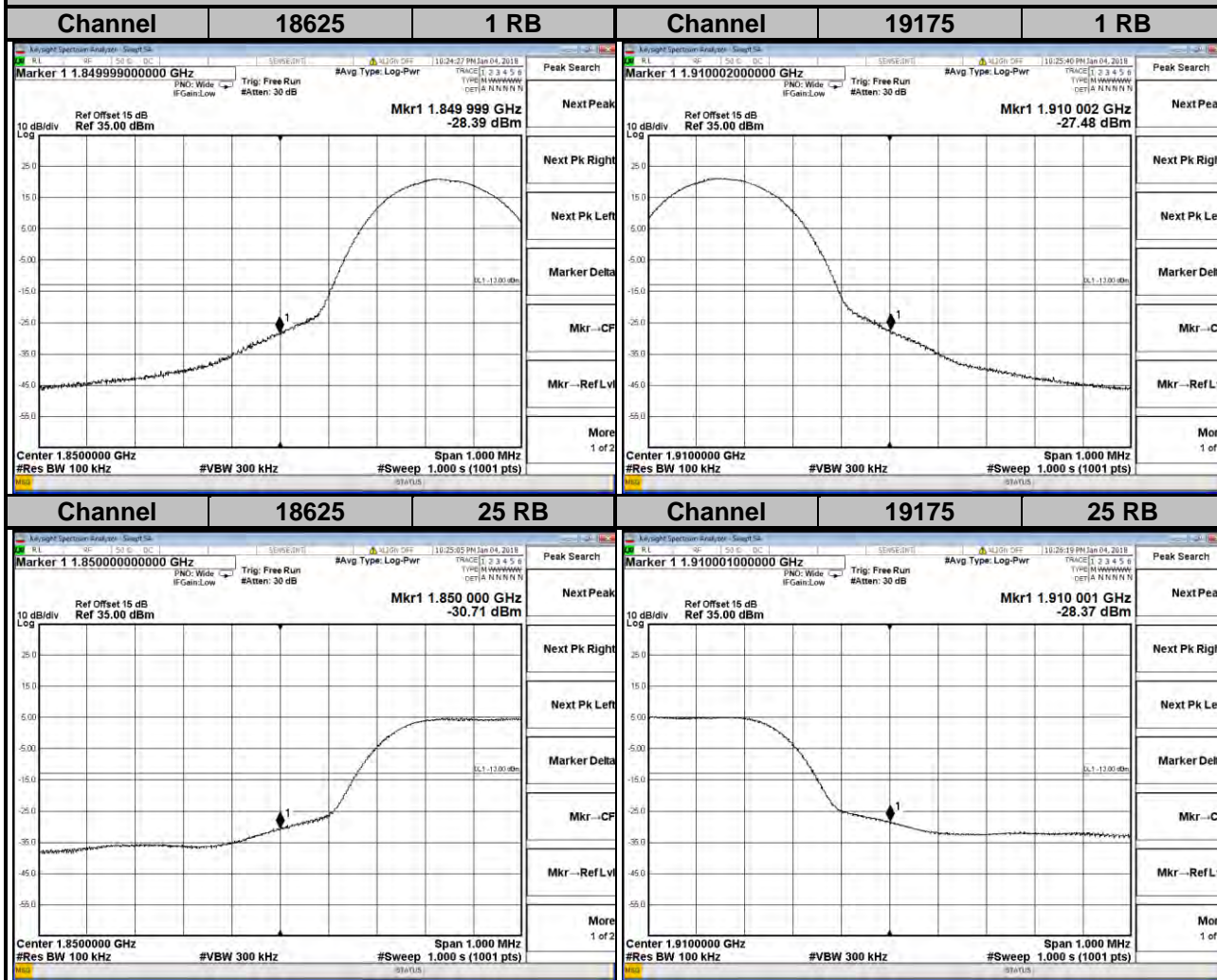

LTE Band 2
Channel Bandwidth: 10 MHz

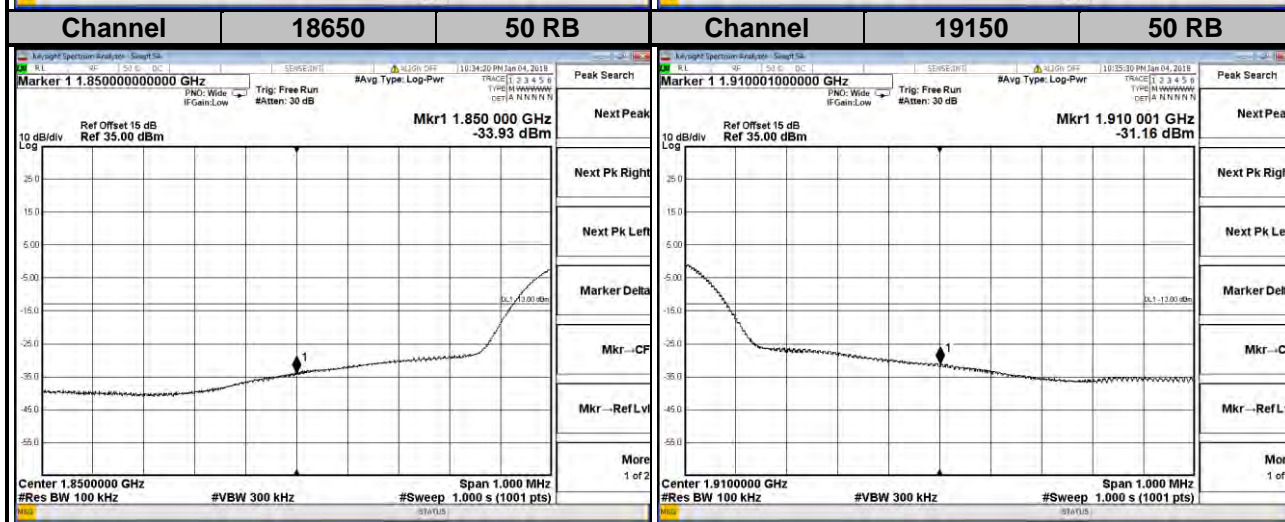
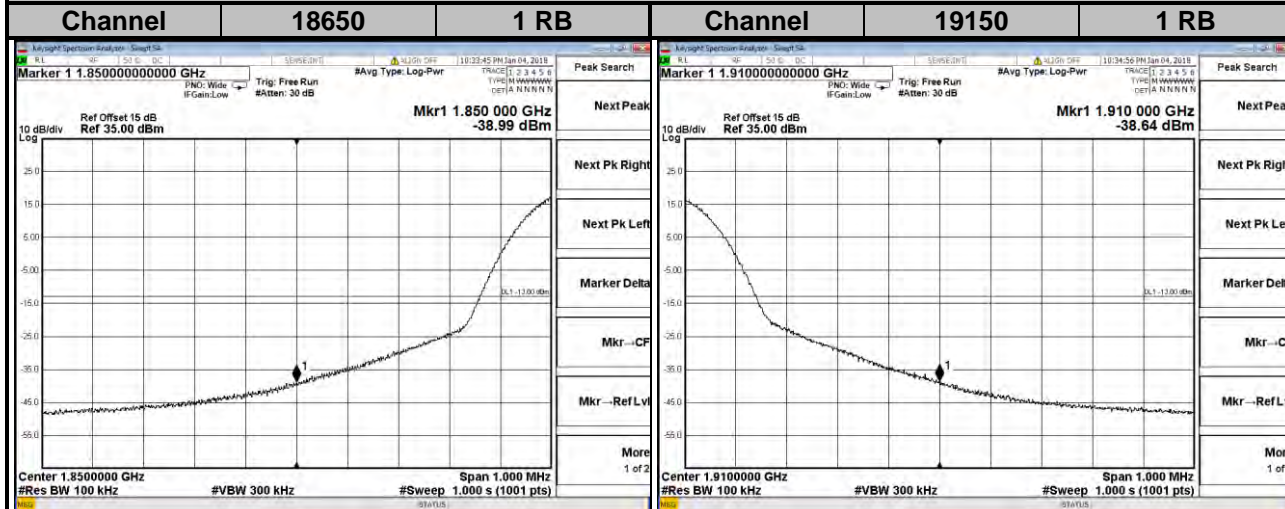

LTE Band 2
Channel Bandwidth: 15 MHz

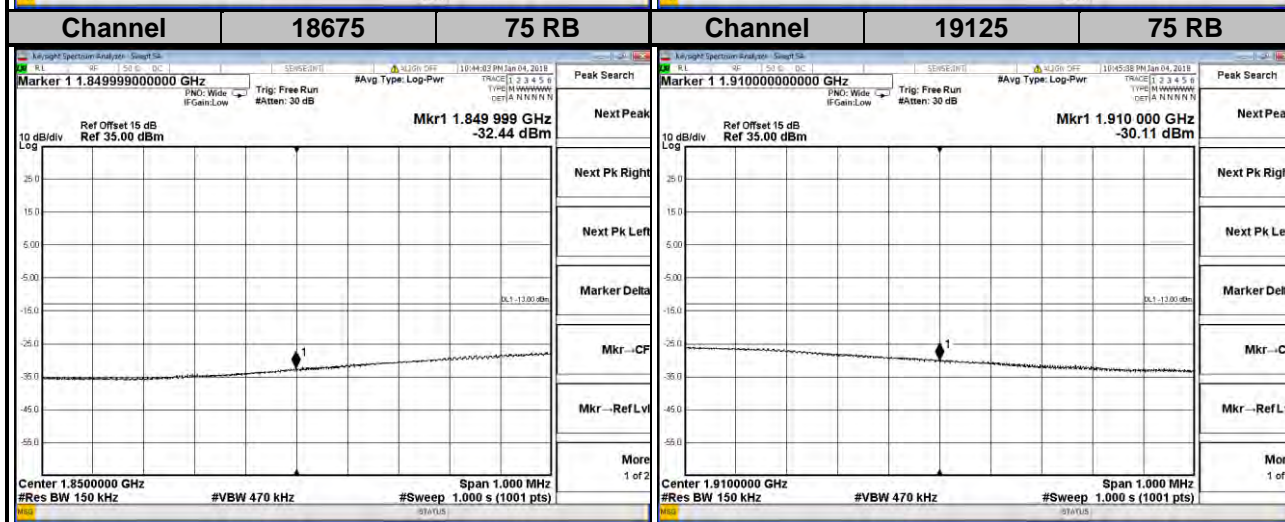
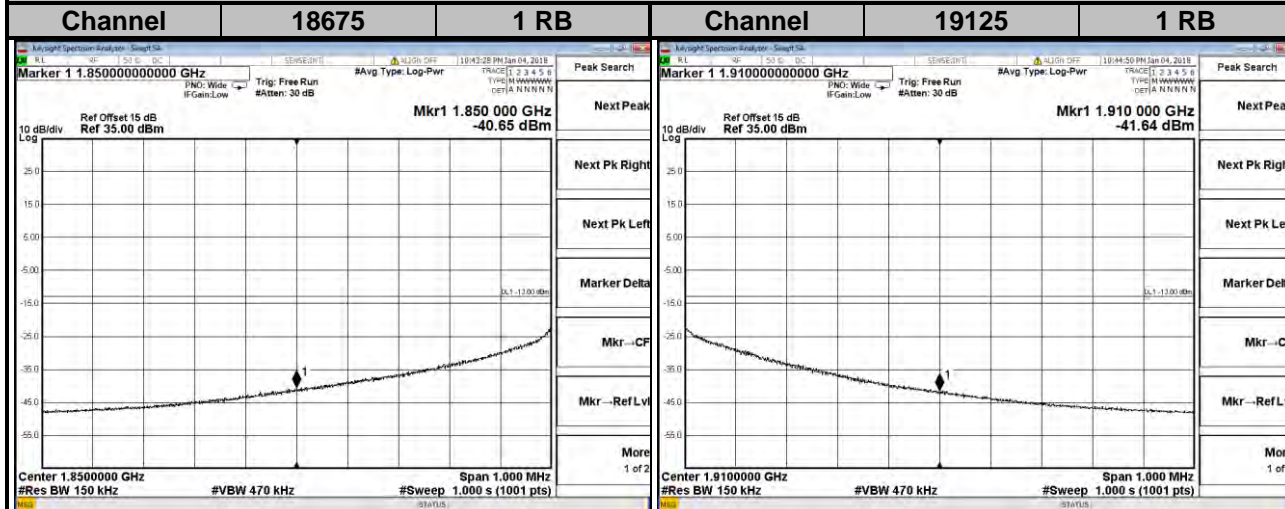

LTE Band 2
Channel Bandwidth: 20 MHz

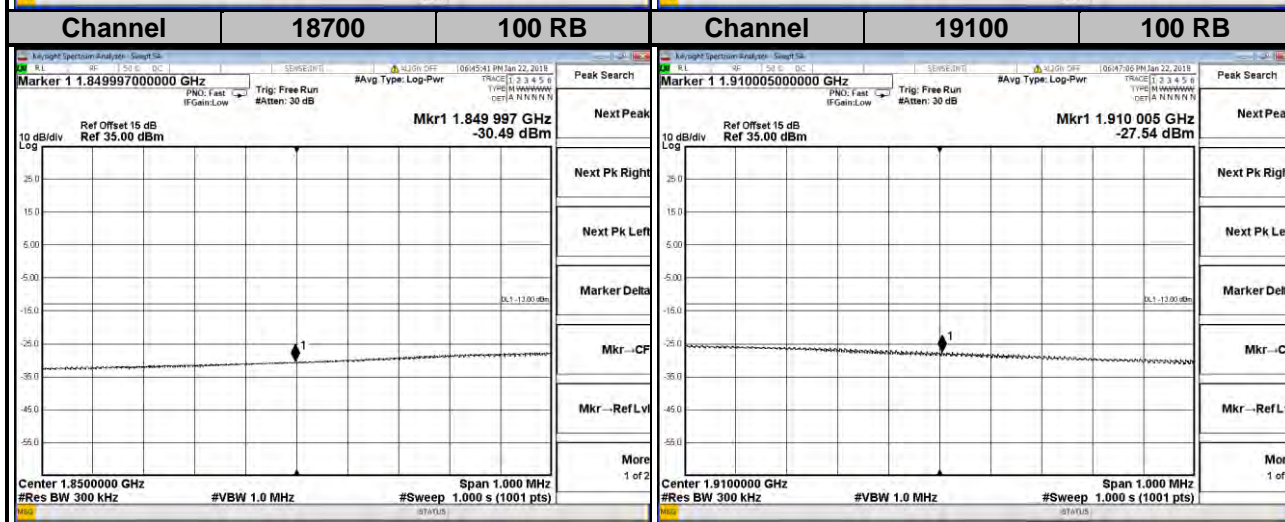
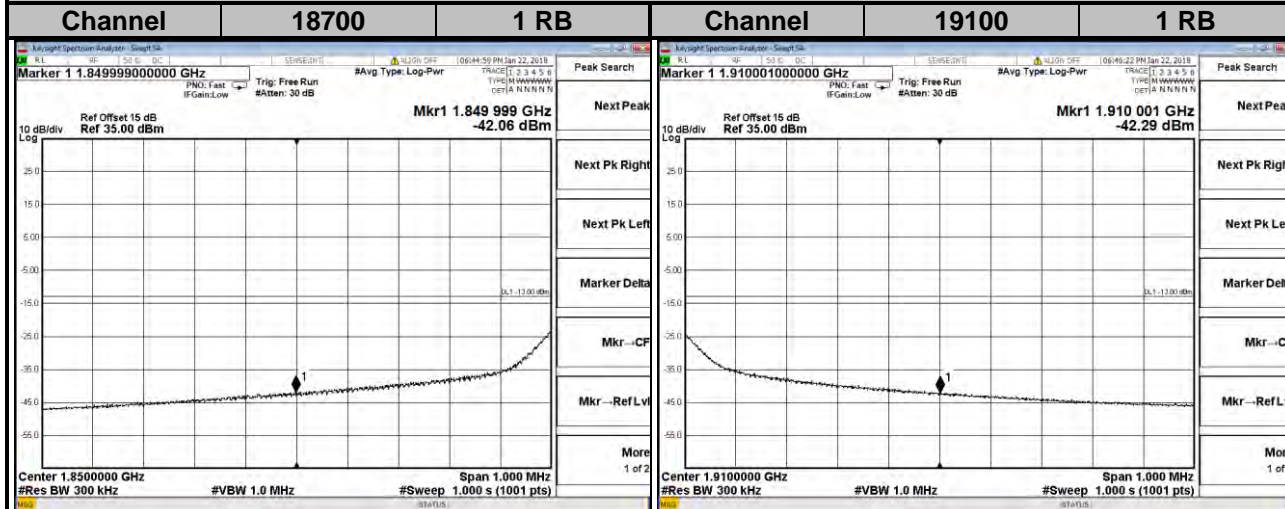

4.5 Peak to Average Ratio

4.5.1 Limits of Peak to Average Ratio Measurement

In measuring transmissions in this band using an average power technique, the peak to-average ratio (PAR) of the transmission may not exceed 13 dB.

4.5.2 Test Setup

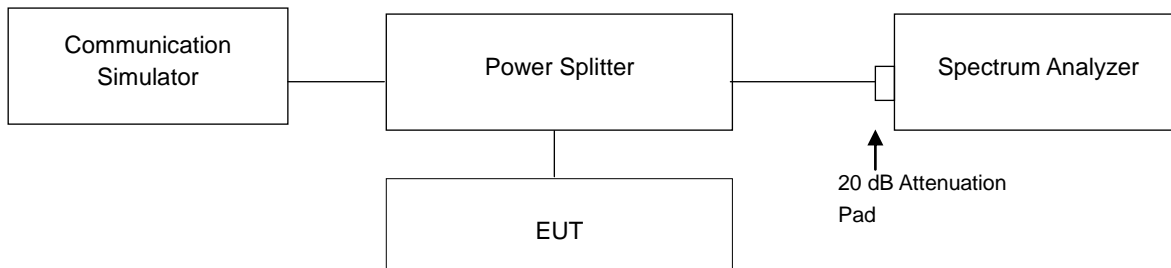

4.5.3 Test Procedures

1. Set resolution/measurement bandwidth \geq signal's occupied bandwidth;
2. Set the number of counts to a value that stabilizes the measured CCDF curve;
3. Record the maximum PAPR level associated with a probability of 0.1 %.

4.5.4 Test Results

Channel	Frequency (MHz)	Peak to Average Ratio (dB)		Channel	Frequency (MHz)	Peak to Average Ratio (dB)
		GSM	EDGE			
512	1850.2	0.20	3.14	9262	1852.4	1.57
661	1880.0	0.19	3.11	9400	1880.0	1.74
810	1909.8	0.16	3.06	9538	1907.6	1.70

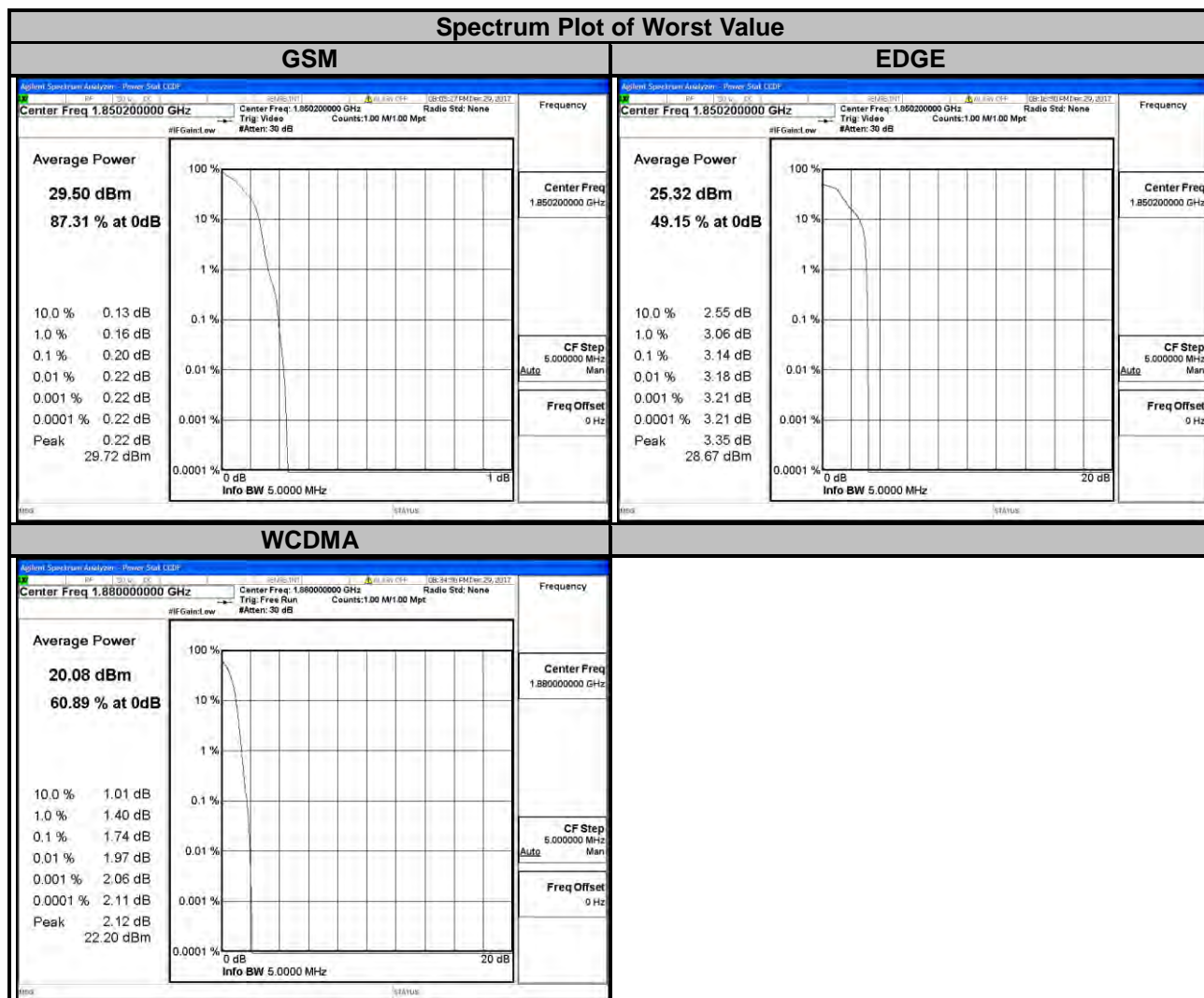

LTE Band 2									
Channel Bandwidth: 1.4 MHz					Channel Bandwidth: 3 MHz				
Channel	Frequency (MHz)	Peak to Average Ratio (dB)			Channel	Frequency (MHz)	Peak to Average Ratio (dB)		
		QPSK	16QAM	64QAM			QPSK	16QAM	64QAM
18607	1850.7	3.82	5.47	5.53	18615	1851.5	3.59	5.37	5.45
18900	1880.0	3.85	5.61	5.51	18900	1880.0	3.61	5.35	5.47
19193	1909.3	3.83	5.35	5.29	19185	1908.5	3.63	5.46	5.44

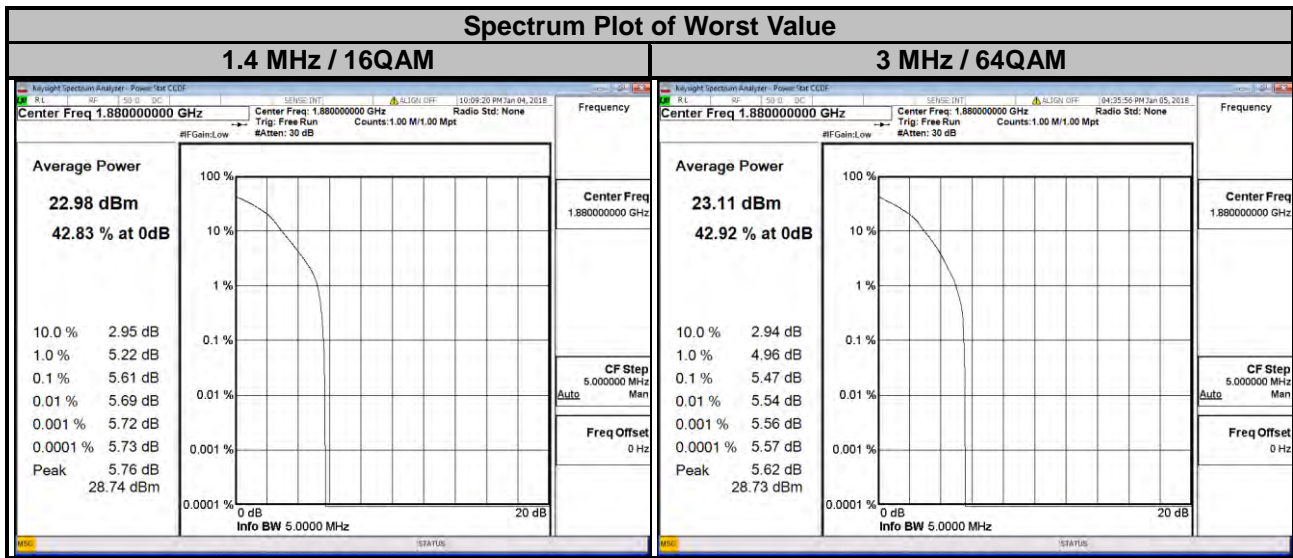

LTE Band 2

Channel Bandwidth: 5 MHz					Channel Bandwidth: 10 MHz				
Channel	Frequency (MHz)	Peak to Average Ratio (dB)			Channel	Frequency (MHz)	Peak to Average Ratio (dB)		
		QPSK	16QAM	64QAM			QPSK	16QAM	64QAM
18625	1852.5	3.62	5.32	5.42	18650	1855.0	3.54	5.27	5.40
18900	1880.0	3.65	5.45	5.39	18900	1880.0	3.54	5.30	5.37
19175	1907.5	3.64	5.31	5.27	19150	1905.0	3.53	4.93	5.09

Spectrum Plot of Worst Value

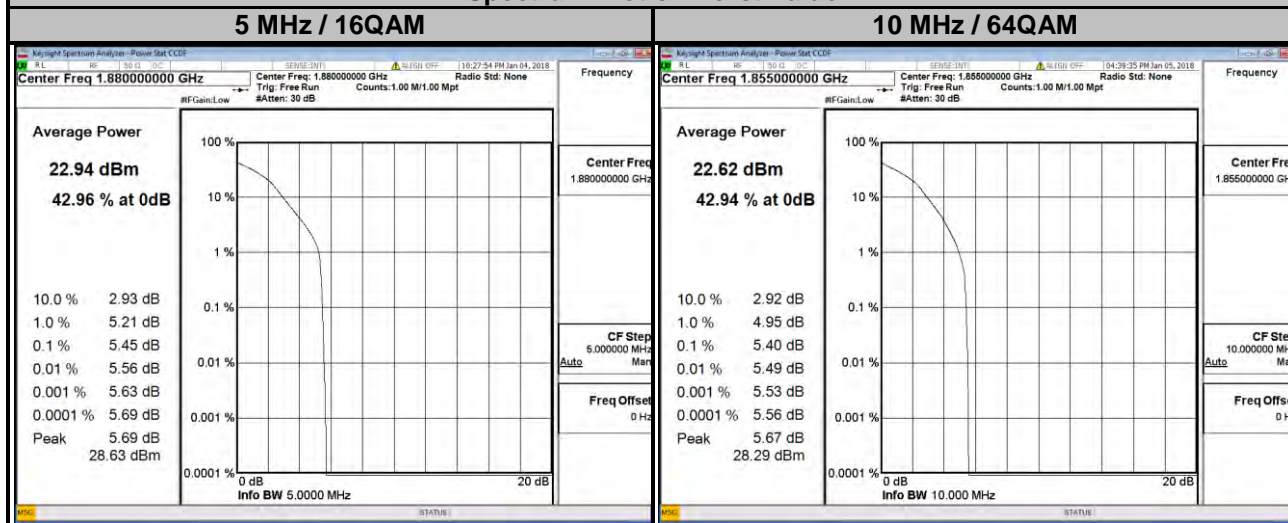

LTE Band 2									
Channel Bandwidth: 15 MHz					Channel Bandwidth: 20 MHz				
Channel	Frequency (MHz)	Peak to Average Ratio (dB)			Channel	Frequency (MHz)	Peak to Average Ratio (dB)		
		QPSK	16QAM	64QAM			QPSK	16QAM	64QAM
18675	1857.5	3.51	5.26	5.39	18700	1860.0	3.49	5.18	5.35
18900	1880.0	3.53	5.25	5.35	18900	1880.0	3.43	5.26	4.48
19125	1902.5	3.50	4.93	5.10	19100	1900.0	3.51	5.03	5.04

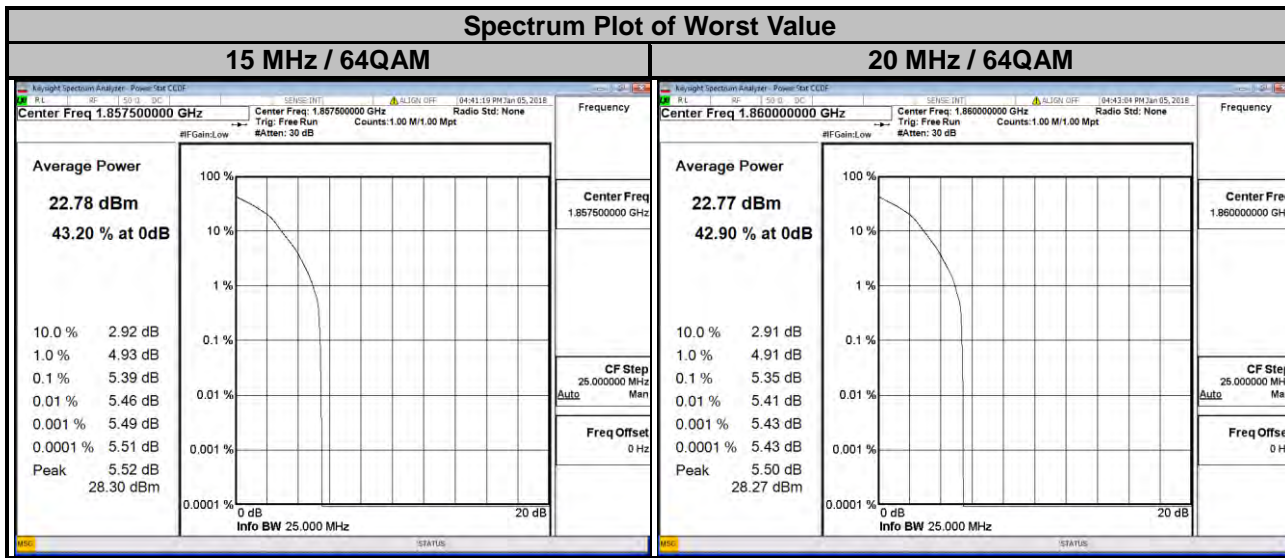

4.6 Conducted Spurious Emissions

4.6.1 Limits of Conducted Spurious Emissions Measurement

The power of any emission outside of the authorized operating frequency ranges must be attenuated below the transmitting power (P) by a factor of at least $43 + 10 \log(P)$ dB. The emission limit equal to -13 dBm.

4.6.2 Test Setup

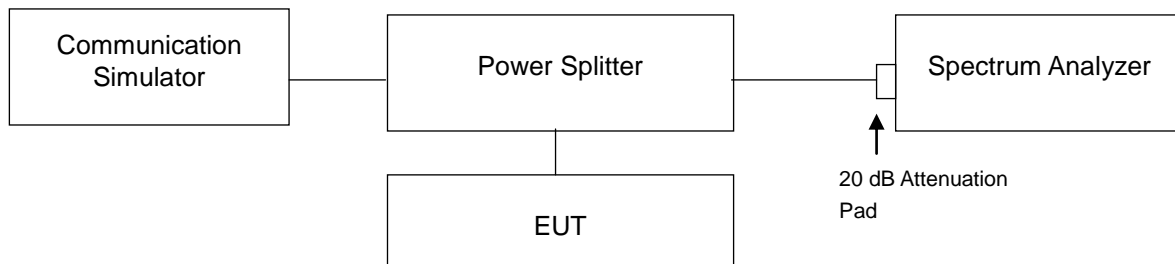

4.6.3 Test Procedure

- The EUT makes a phone call to the communication simulator. All measurements were done at low, middle and high operational frequency range.
- Measuring frequency range is from 30 MHz to 26.5 GHz. 20 dB attenuation pad is connected with spectrum. RBW = 1 MHz and VBW = 3 MHz is used for conducted spurious emission measurement.

4.6.4 Test Results

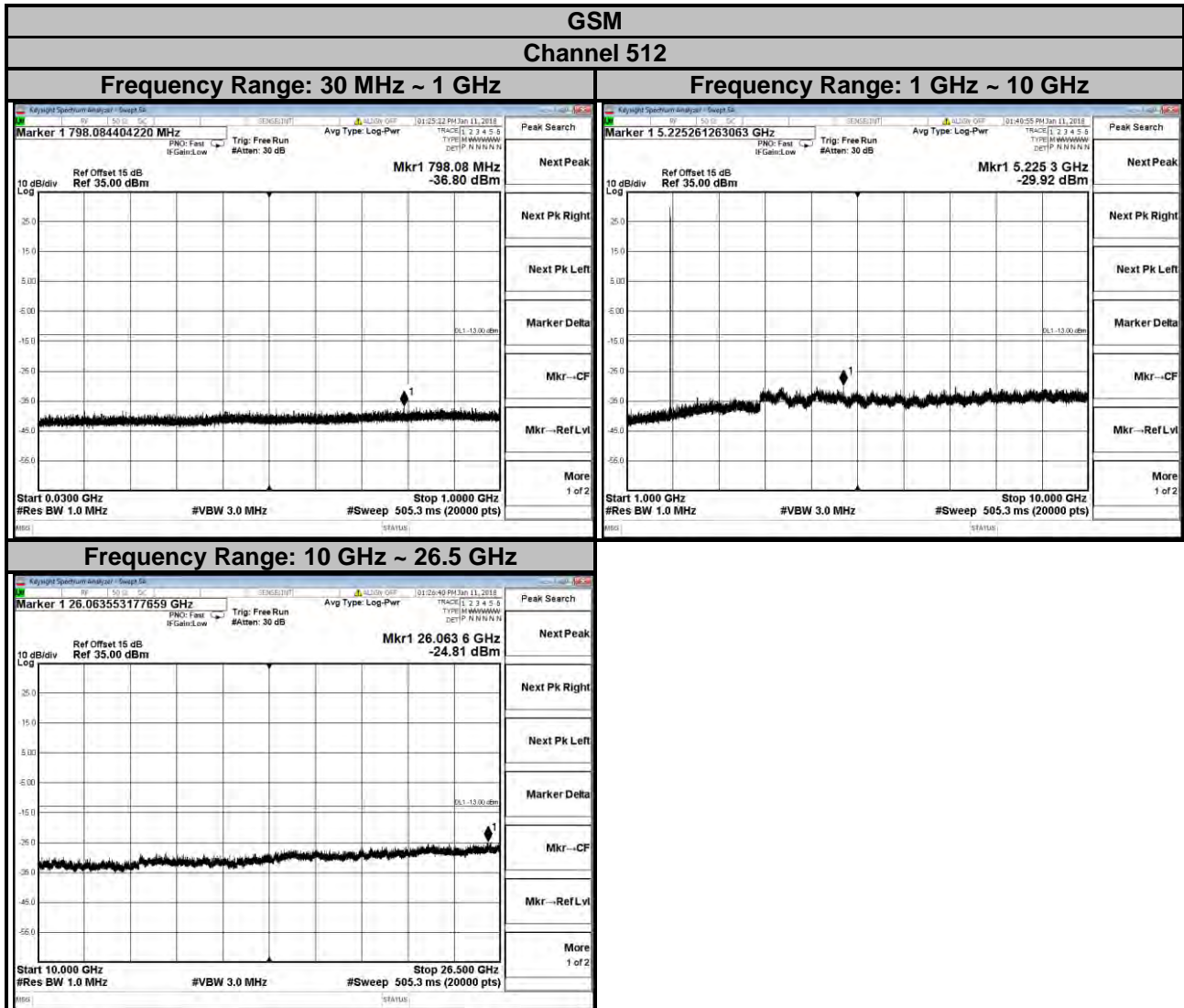

GSM

Channel 661

Frequency Range: 30 MHz ~ 1 GHz

Frequency Range: 1 GHz ~ 10 GHz

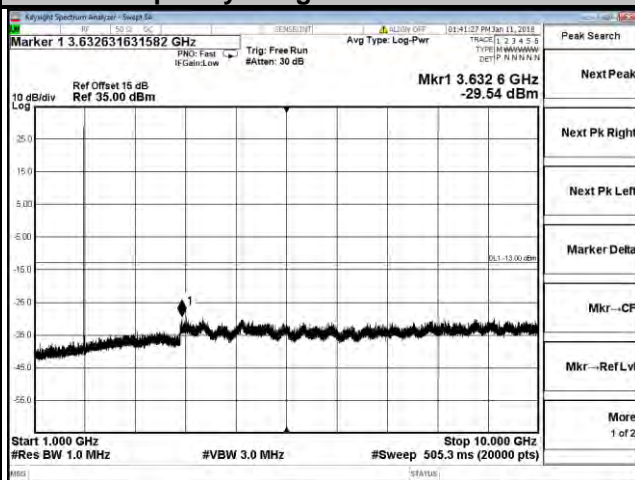
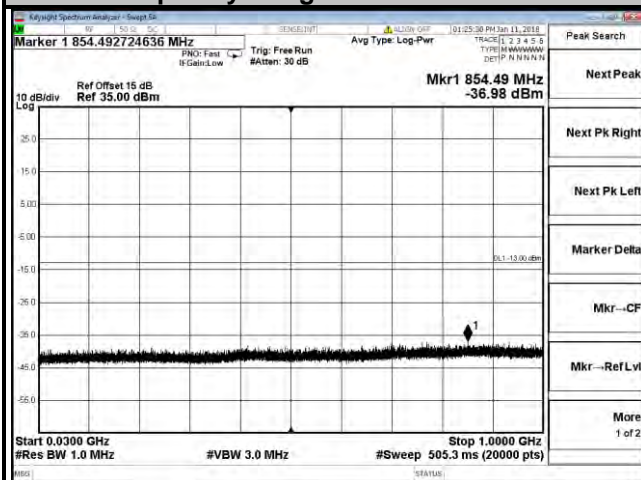

Frequency Range: 10 GHz ~ 26.5 GHz

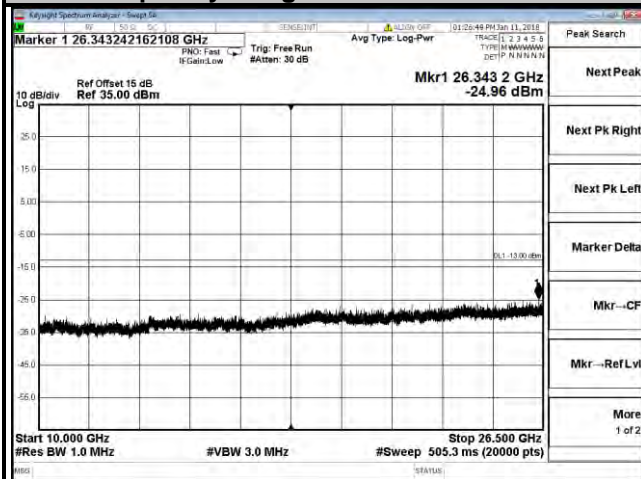

GSM

Channel 810

Frequency Range: 30 MHz ~ 1 GHz

Frequency Range: 1 GHz ~ 10 GHz

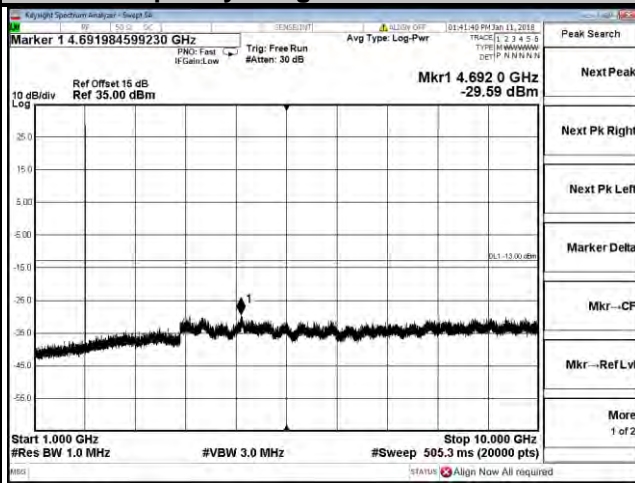
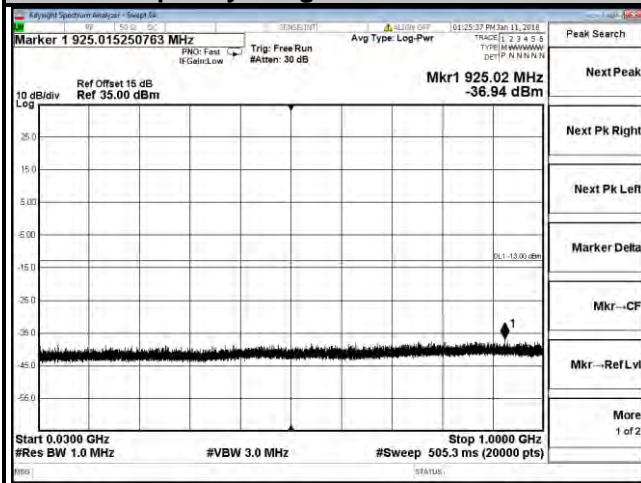

Frequency Range: 10 GHz ~ 26.5 GHz

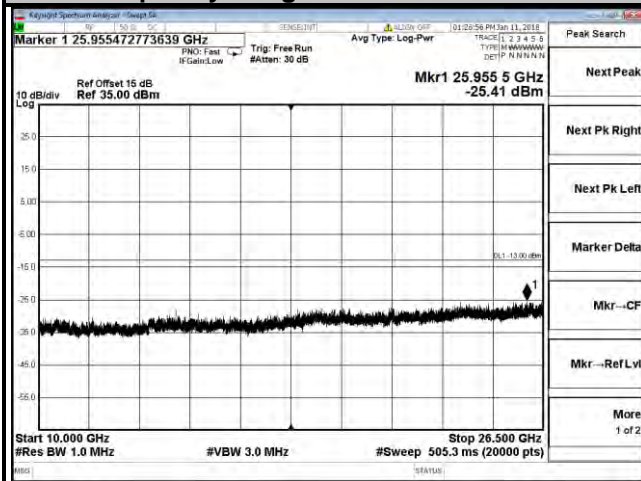

EDGE

Channel 512

Frequency Range: 30 MHz ~ 1 GHz

Frequency Range: 1 GHz ~ 10 GHz

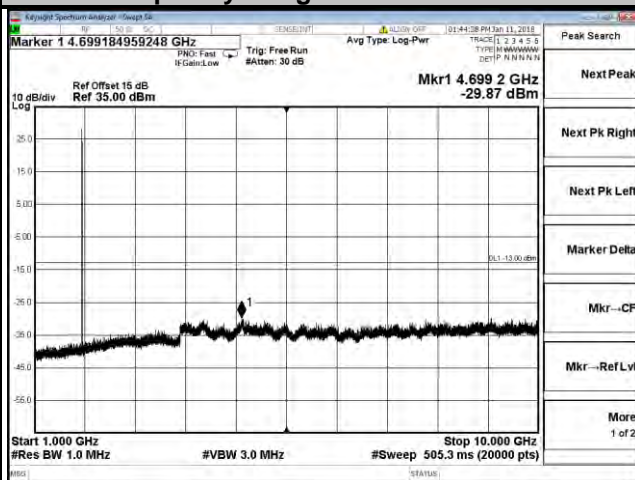
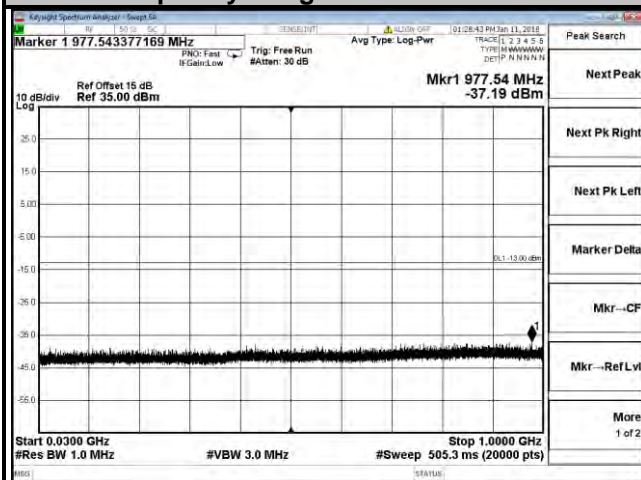

Frequency Range: 10 GHz ~ 26.5 GHz

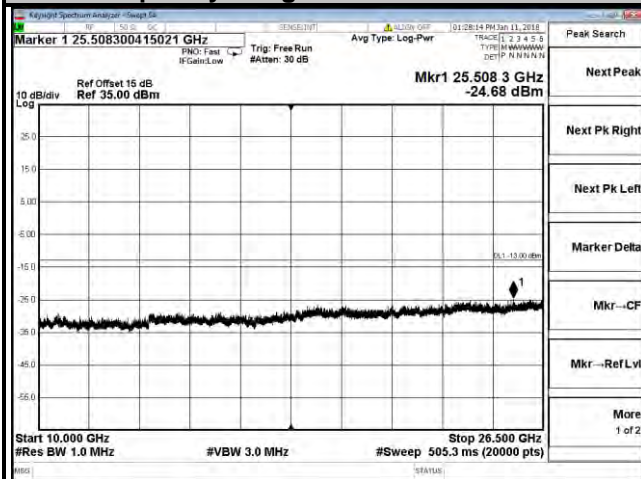

EDGE

Channel 661

Frequency Range: 30 MHz ~ 1 GHz

Frequency Range: 1 GHz ~ 10 GHz

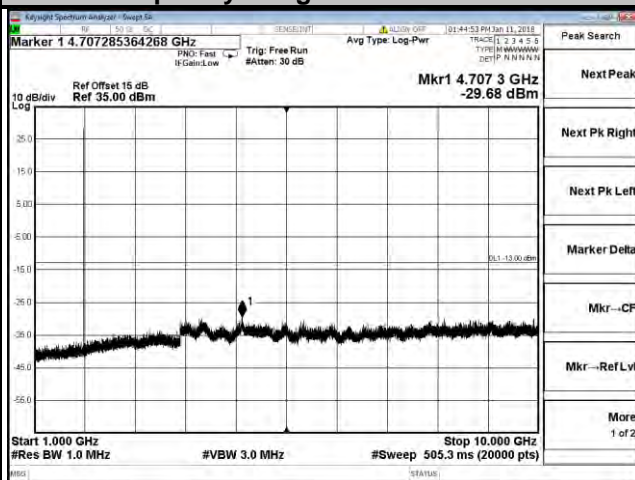
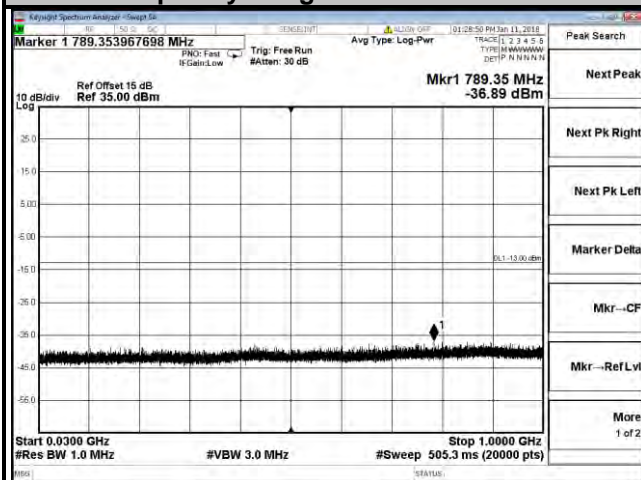

Frequency Range: 10 GHz ~ 26.5 GHz

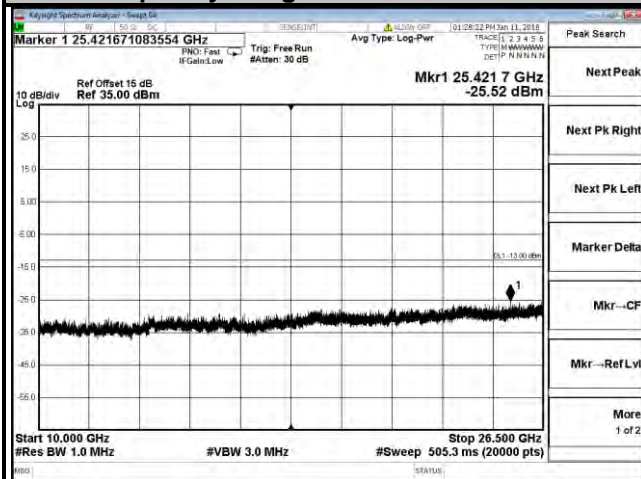

EDGE

Channel 810

Frequency Range: 30 MHz ~ 1 GHz

Frequency Range: 1 GHz ~ 10 GHz

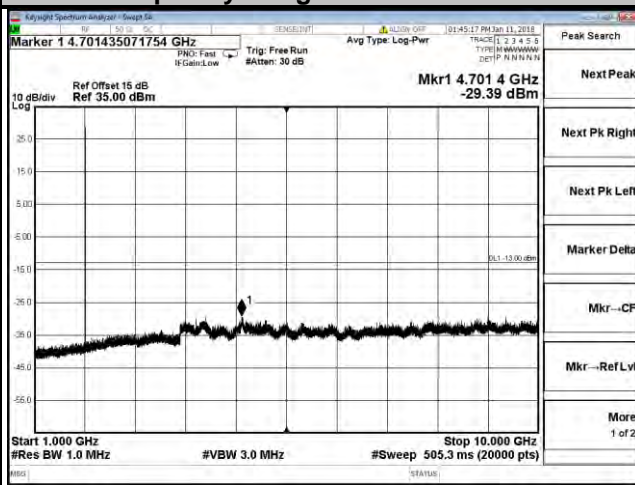
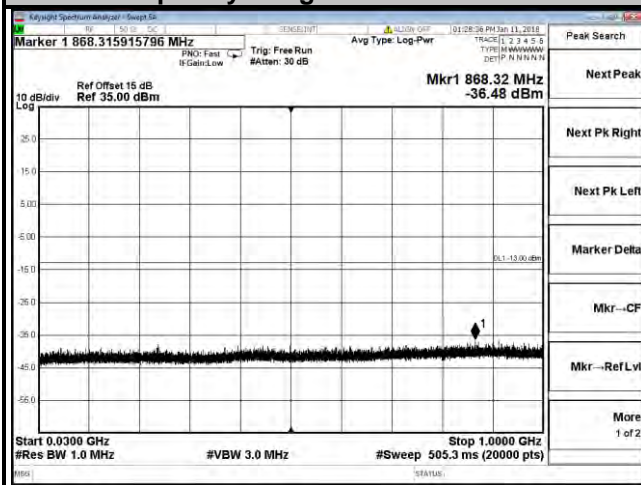

Frequency Range: 10 GHz ~ 26.5 GHz

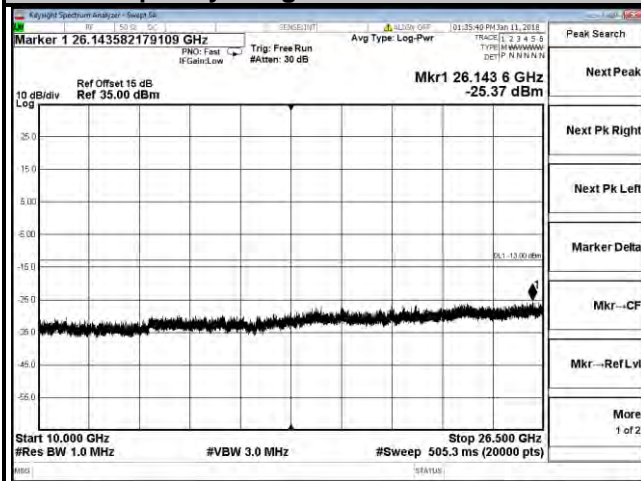

**WCDMA
Channel 9262**

Frequency Range: 30 MHz ~ 1 GHz

Frequency Range: 1 GHz ~ 10 GHz

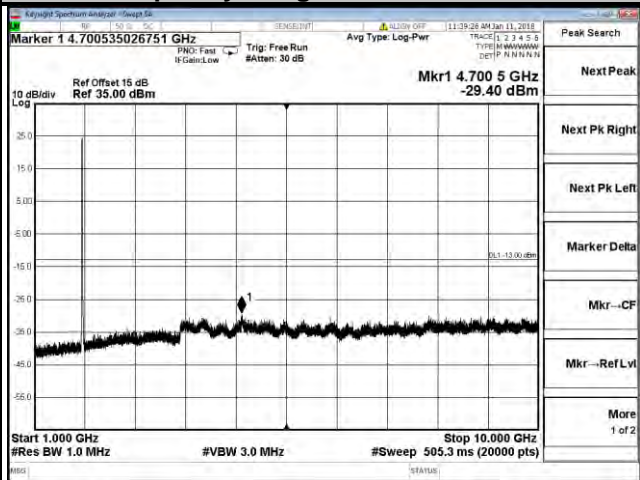
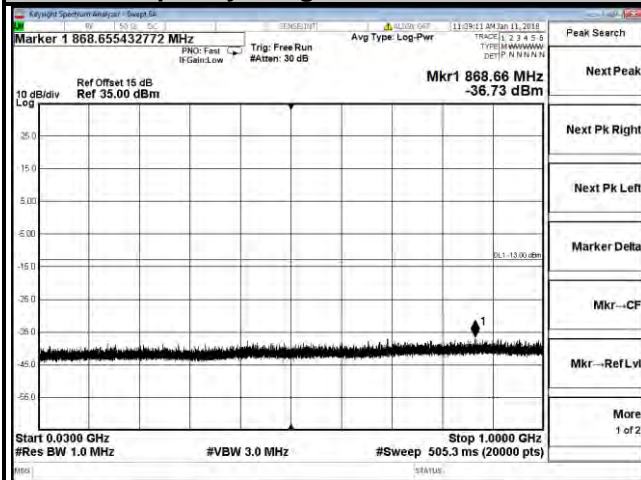

Frequency Range: 10 GHz ~ 26.5 GHz

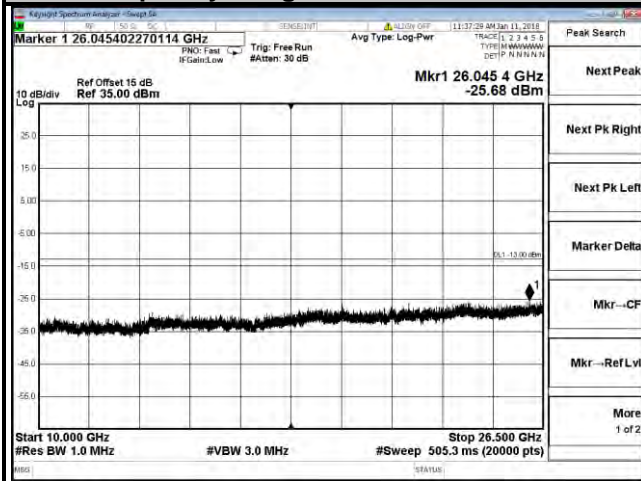

**WCDMA
Channel 9400**

Frequency Range: 30 MHz ~ 1 GHz

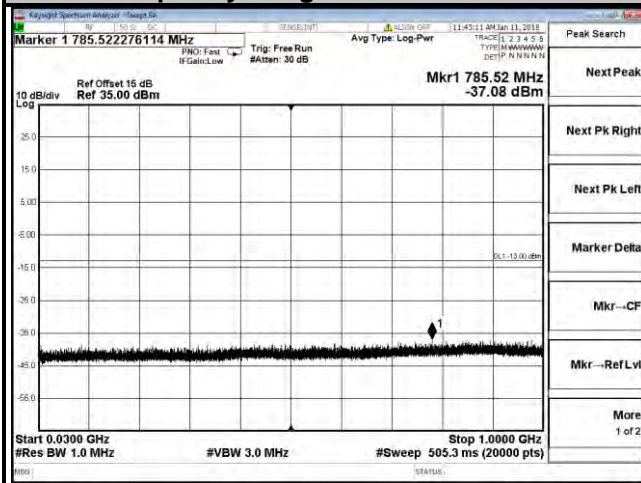

Frequency Range: 1 GHz ~ 10 GHz

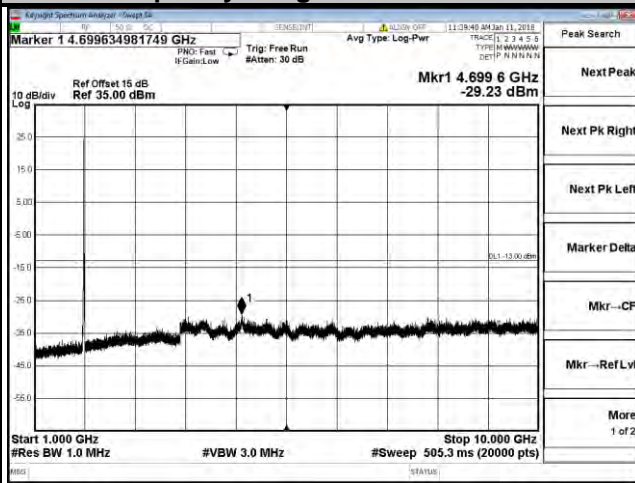

Frequency Range: 10 GHz ~ 26.5 GHz

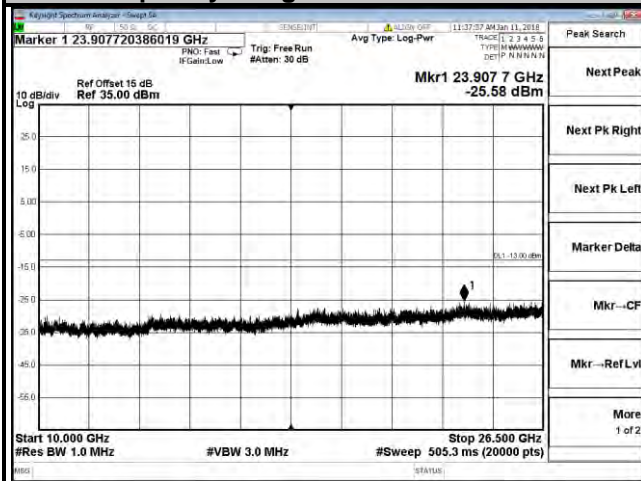

WCDMA
Channel 9538

Frequency Range: 30 MHz ~ 1 GHz

Frequency Range: 1 GHz ~ 10 GHz

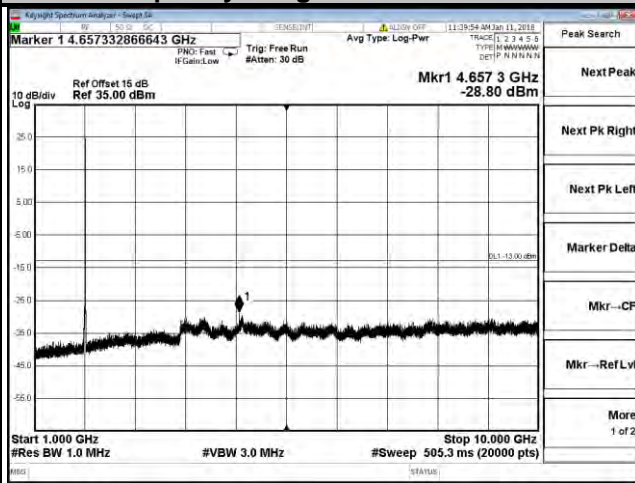
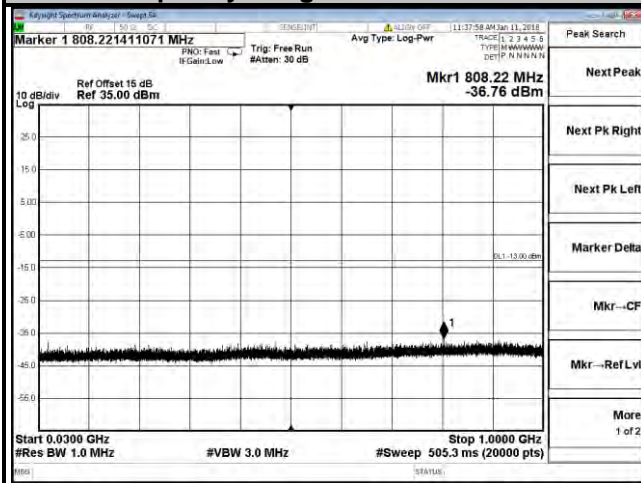

Frequency Range: 10 GHz ~ 26.5 GHz

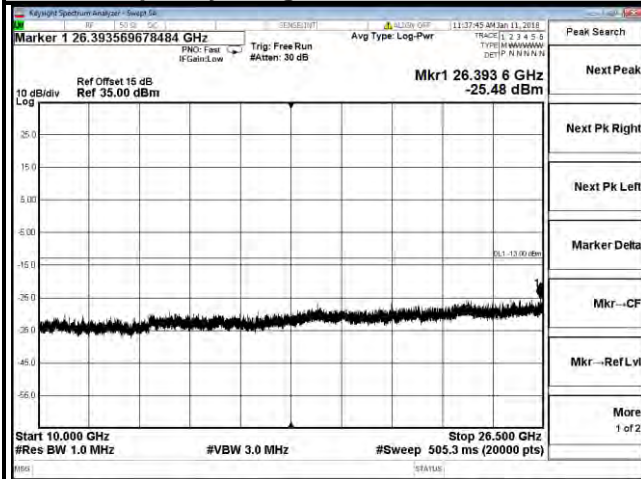

LTE Band 2
Channel Bandwidth: 1.4 MHz
Channel 18607

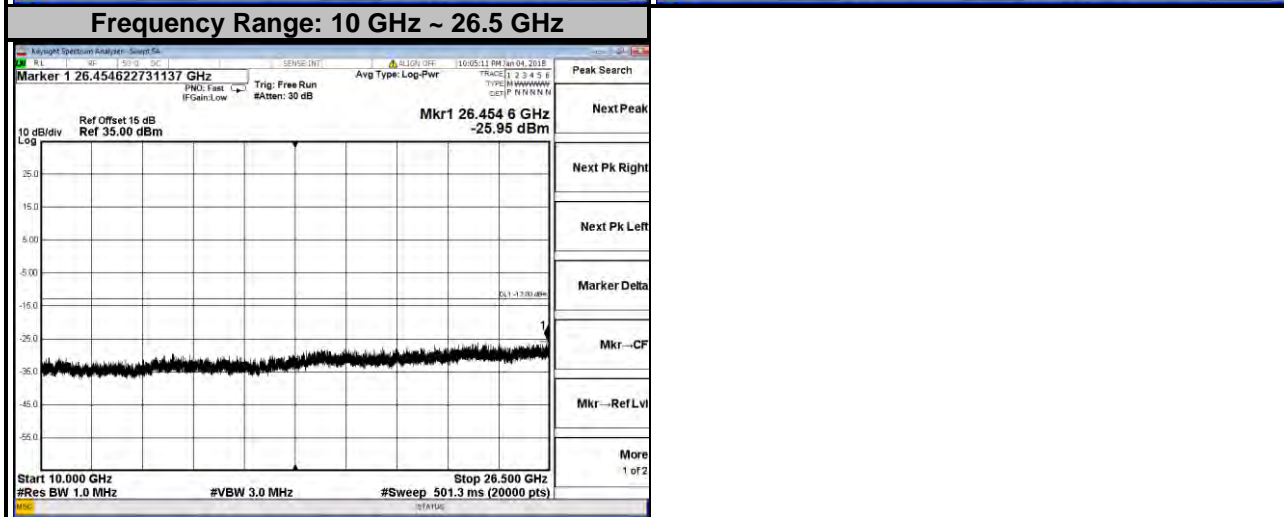
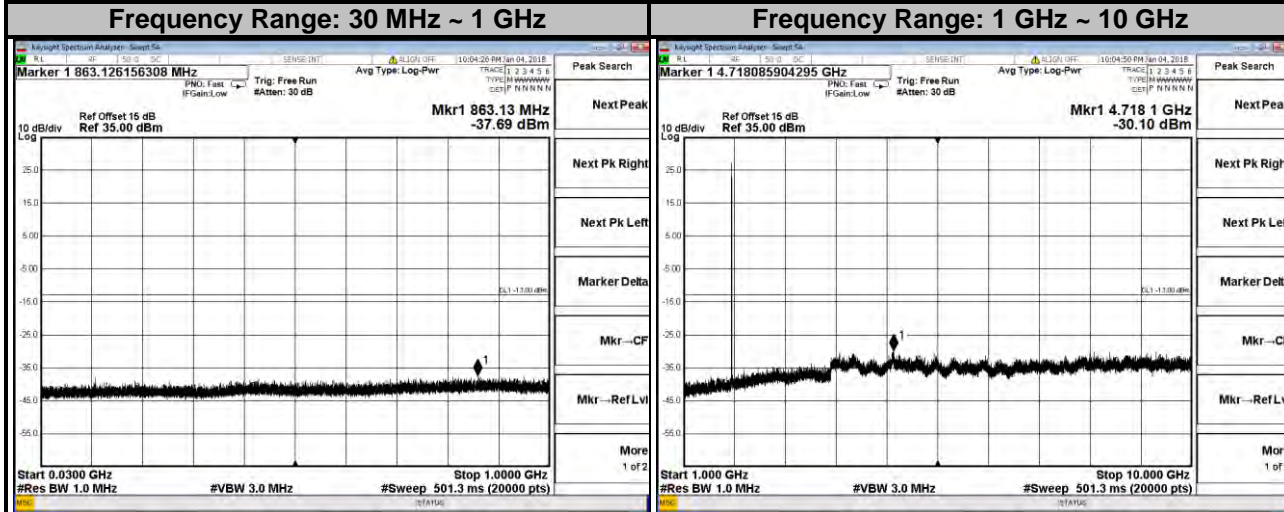

LTE Band 2
Channel Bandwidth: 1.4 MHz
Channel 18900

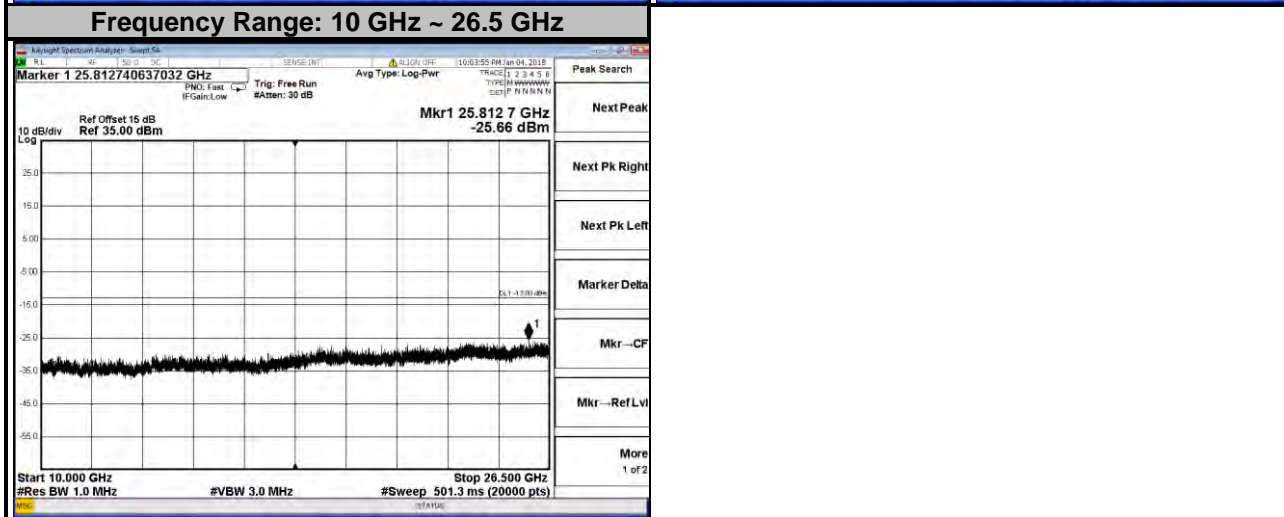
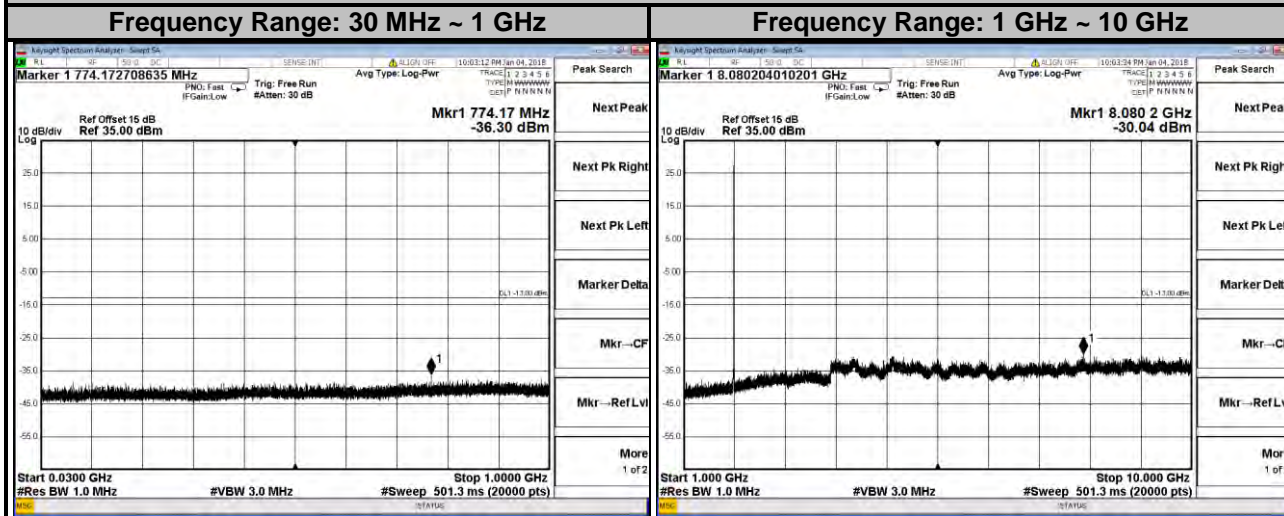

LTE Band 2
Channel Bandwidth: 1.4 MHz
Channel 19193

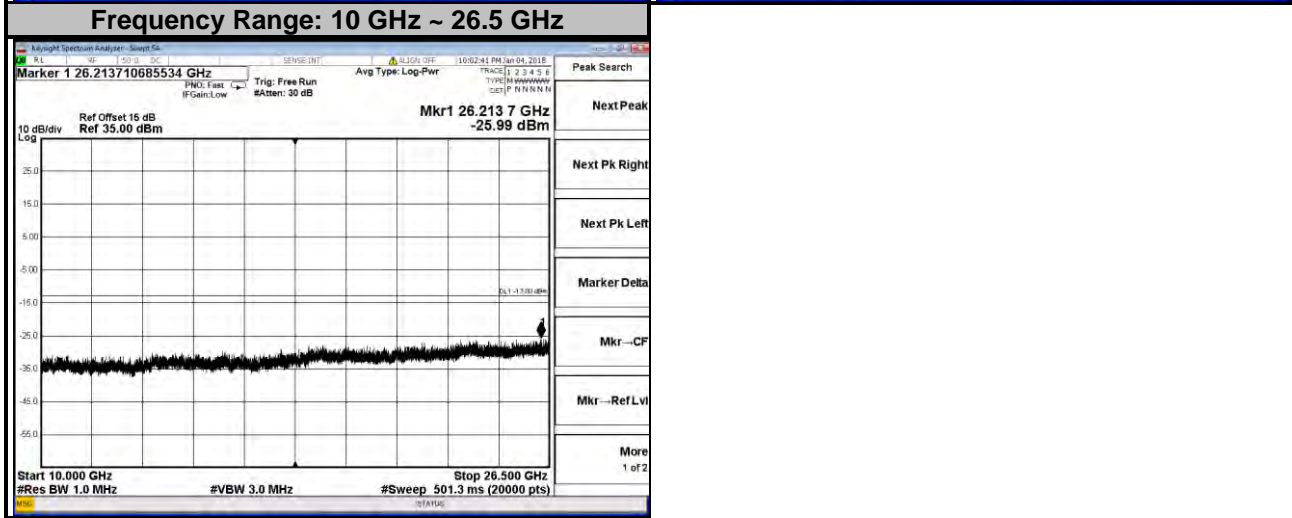
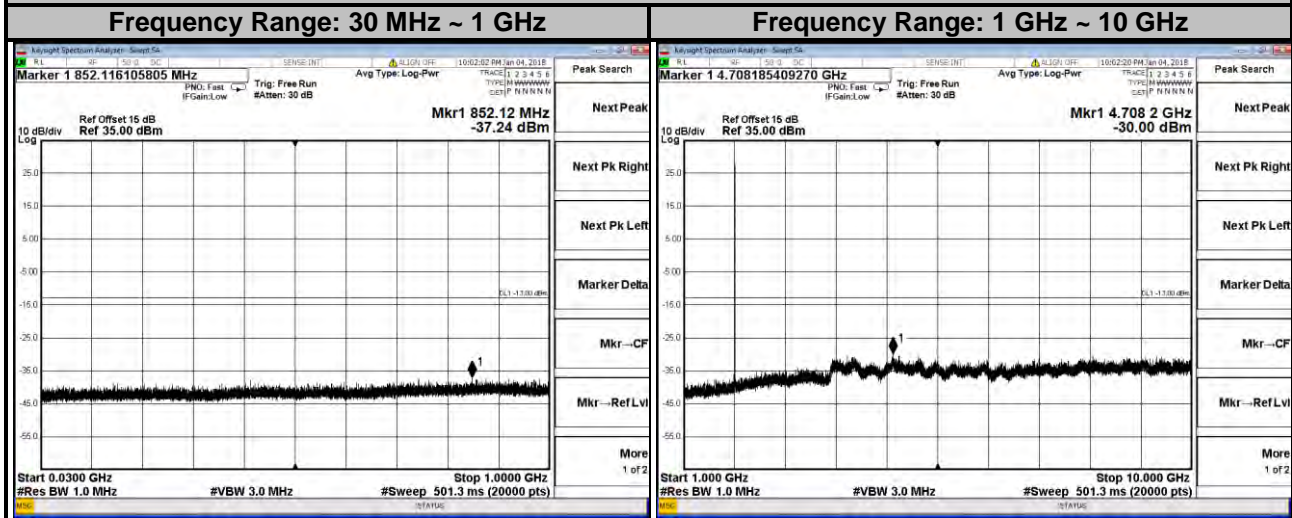

LTE Band 2
Channel Bandwidth: 3 MHz
Channel 18615

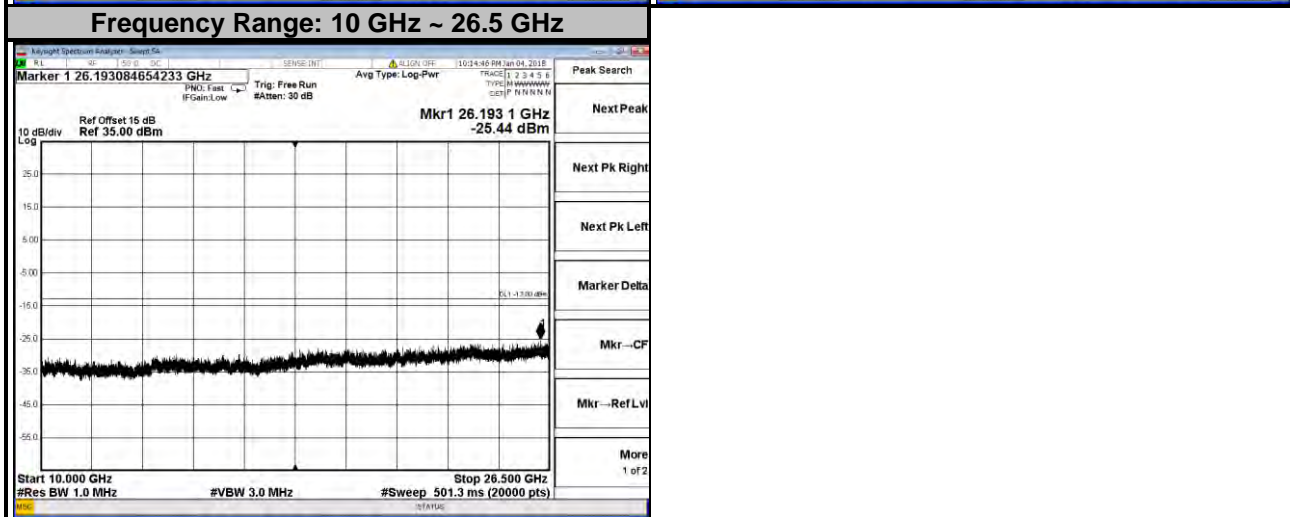
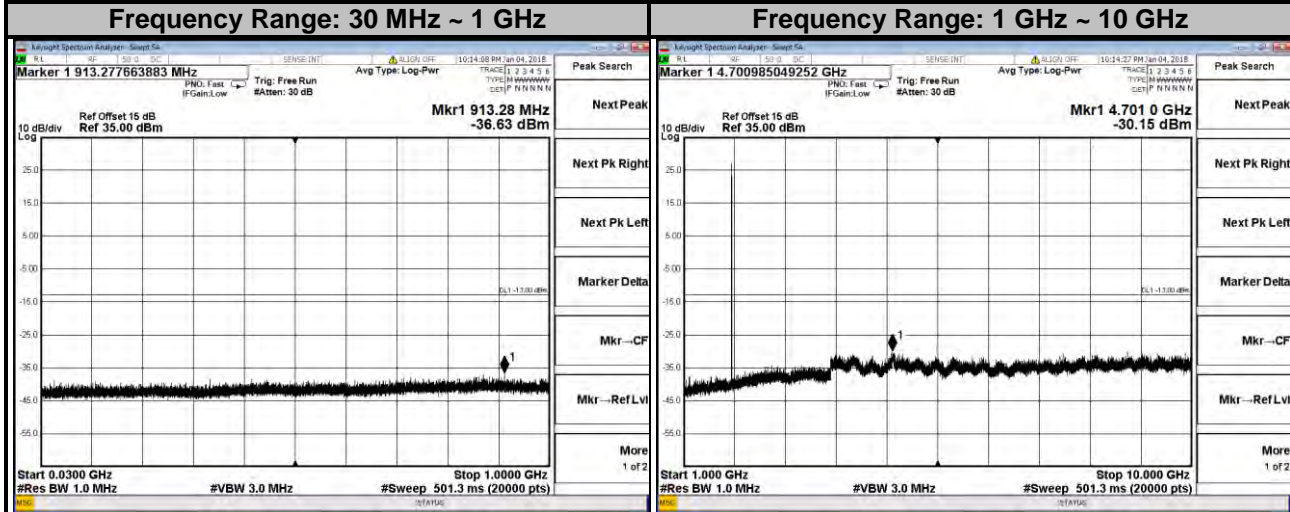

LTE Band 2
Channel Bandwidth: 3 MHz
Channel 18900

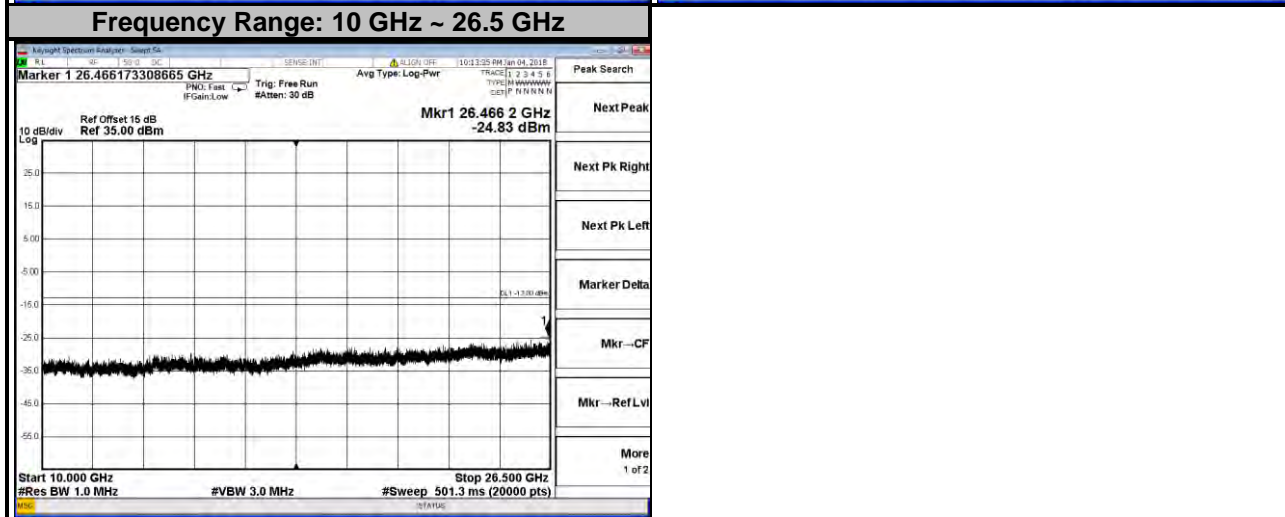
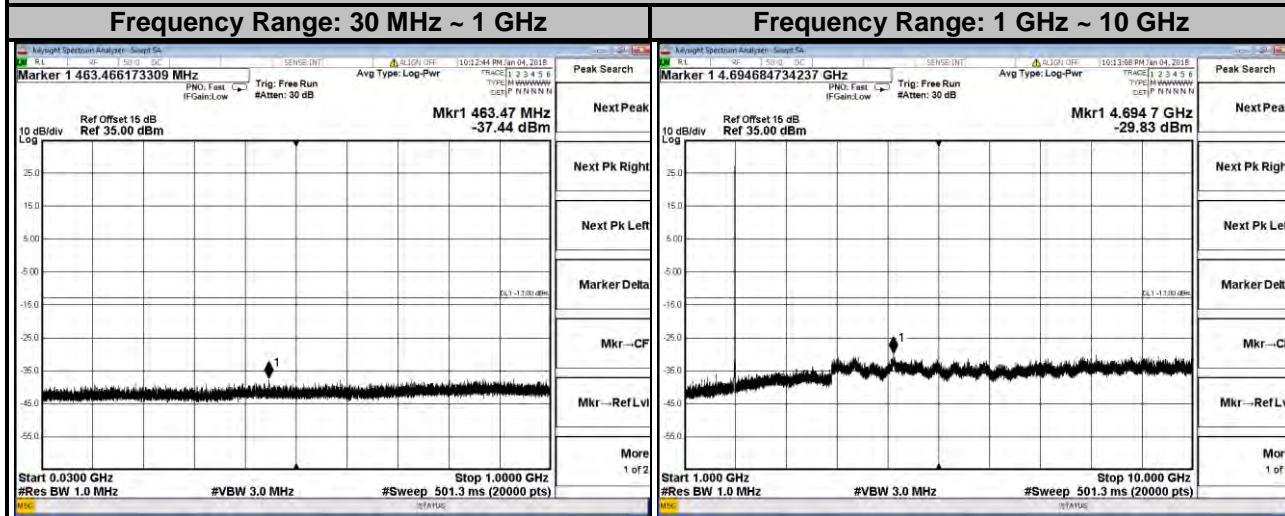

LTE Band 2
Channel Bandwidth: 3 MHz
Channel 19185

Frequency Range: 30 MHz ~ 1 GHz

Frequency Range: 1 GHz ~ 10 GHz

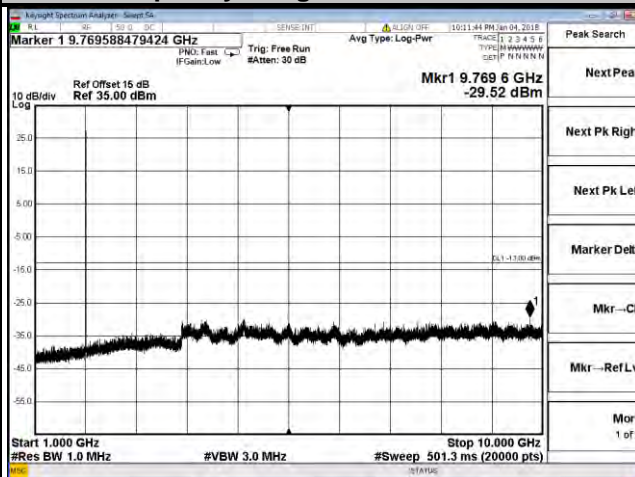
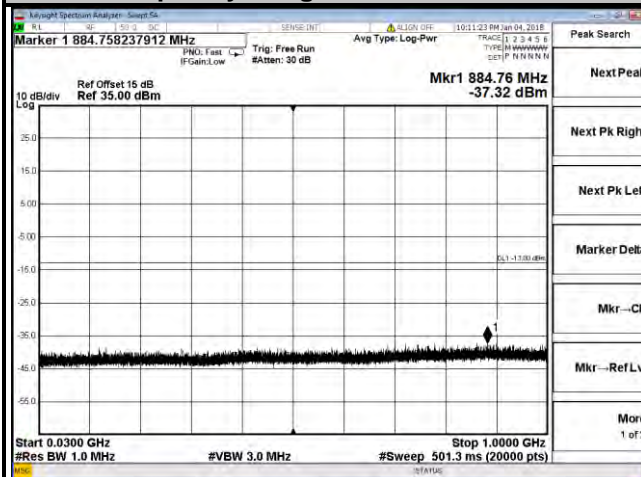

Frequency Range: 10 GHz ~ 26.5 GHz

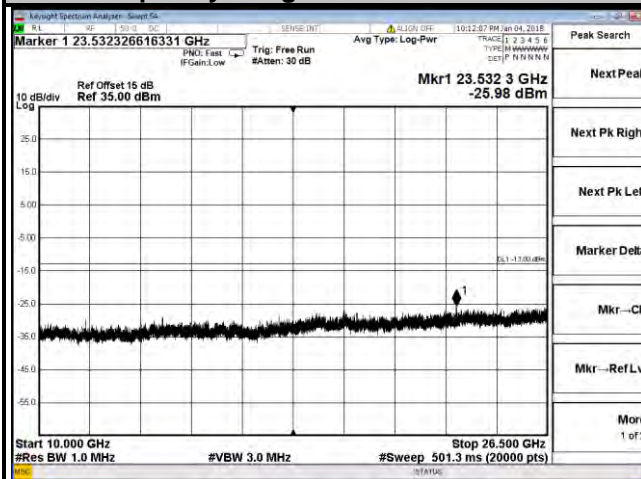

LTE Band 2
Channel Bandwidth: 5 MHz
Channel 18625

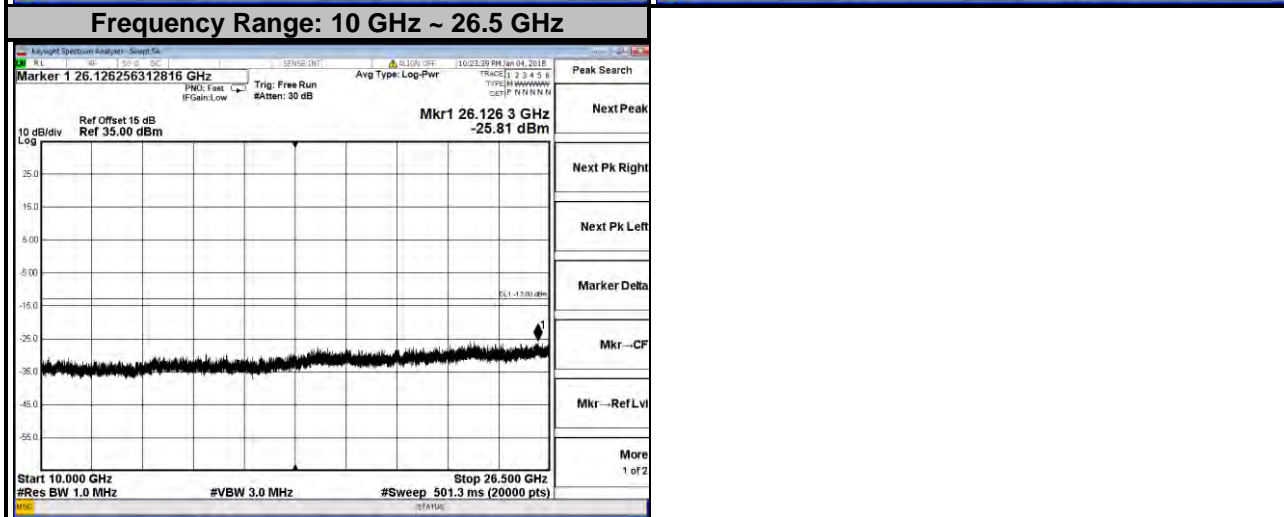
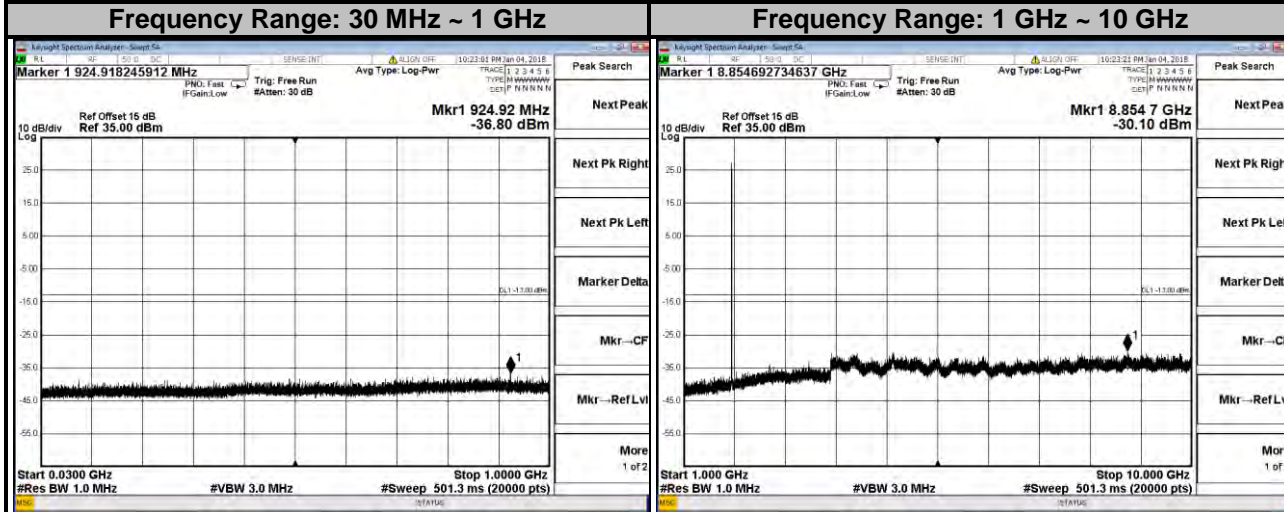

LTE Band 2
Channel Bandwidth: 5 MHz
Channel 18900

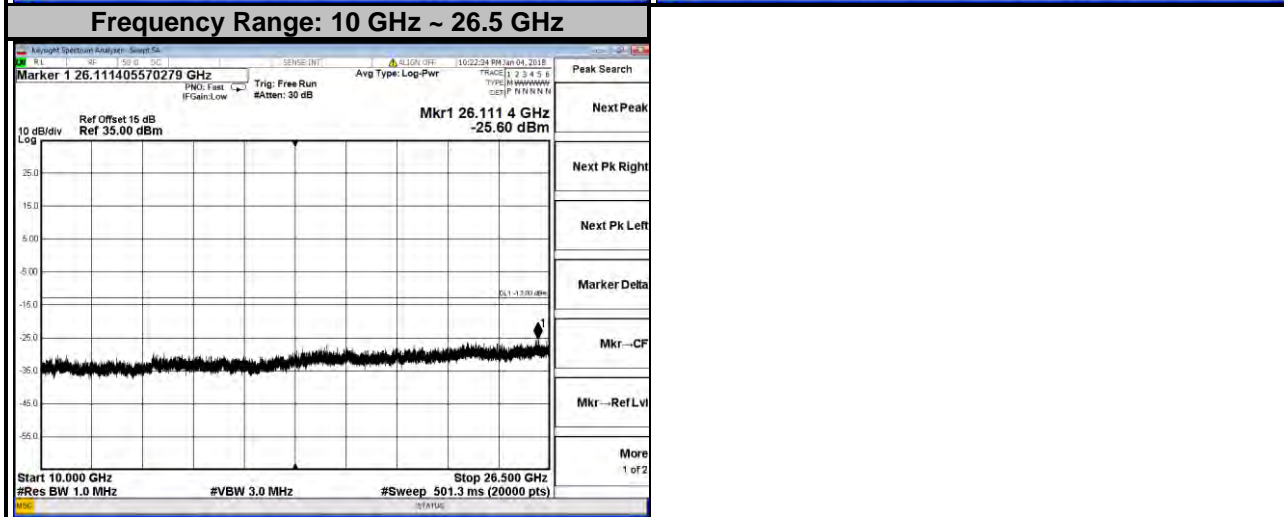
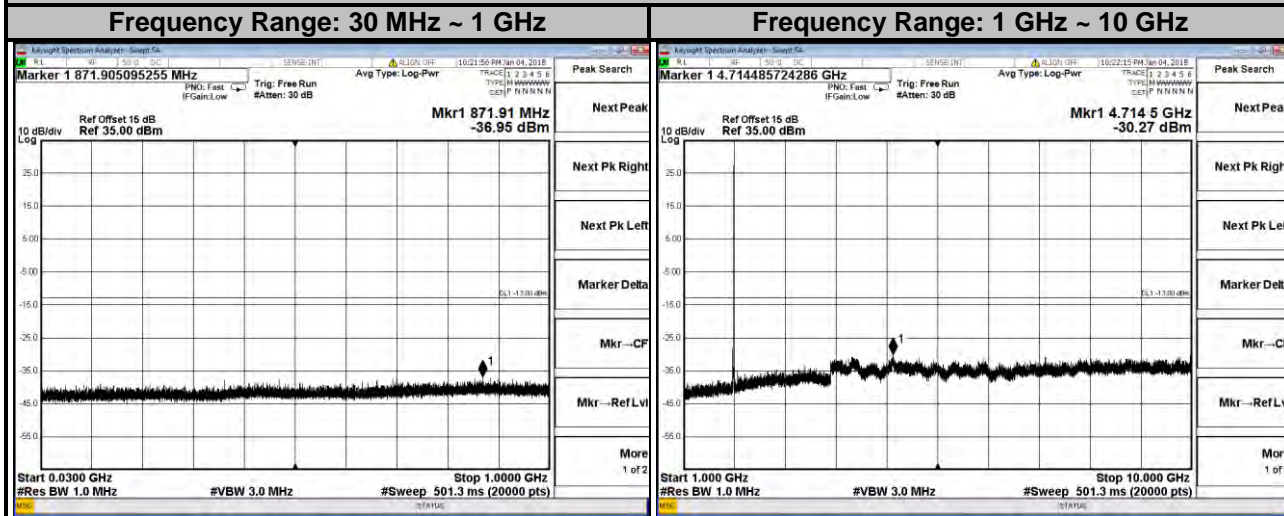

LTE Band 2
Channel Bandwidth: 5 MHz
Channel 19175

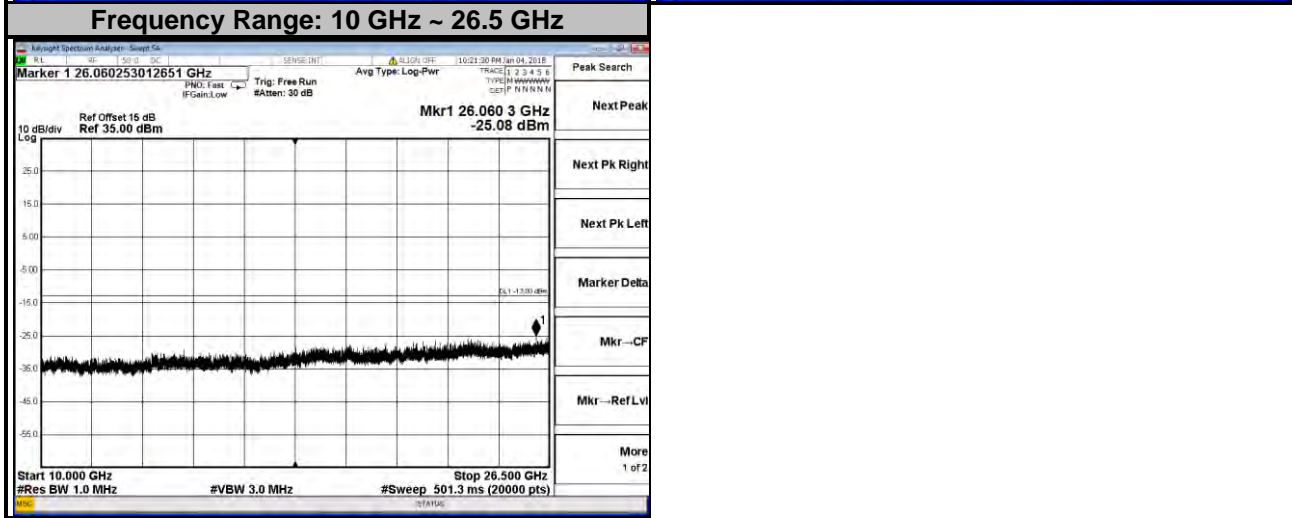
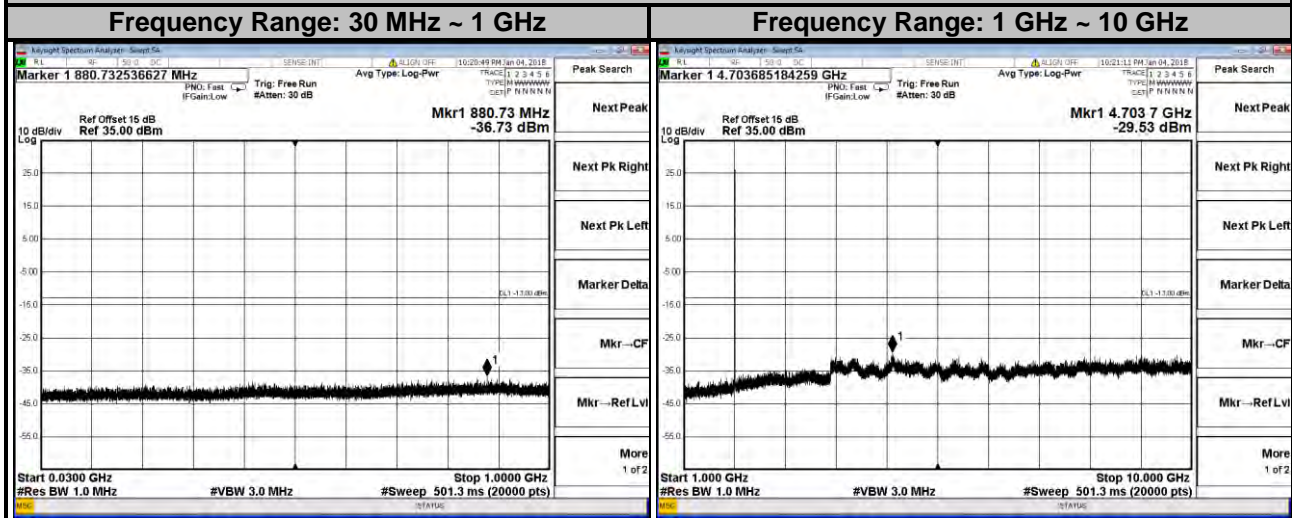

LTE Band 2
Channel Bandwidth: 10 MHz
Channel 18650

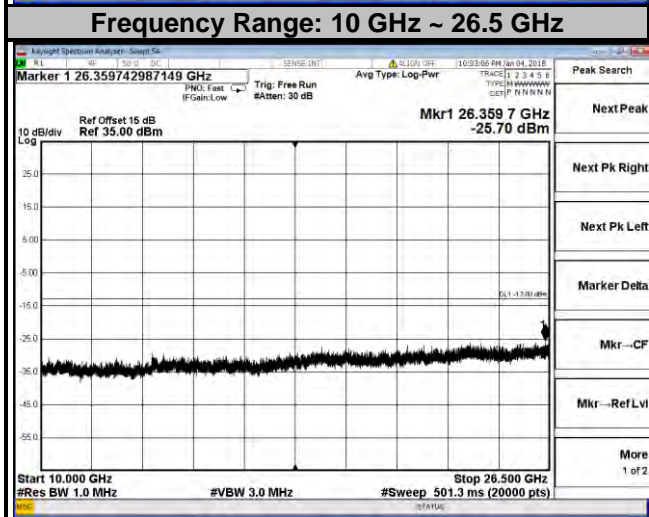
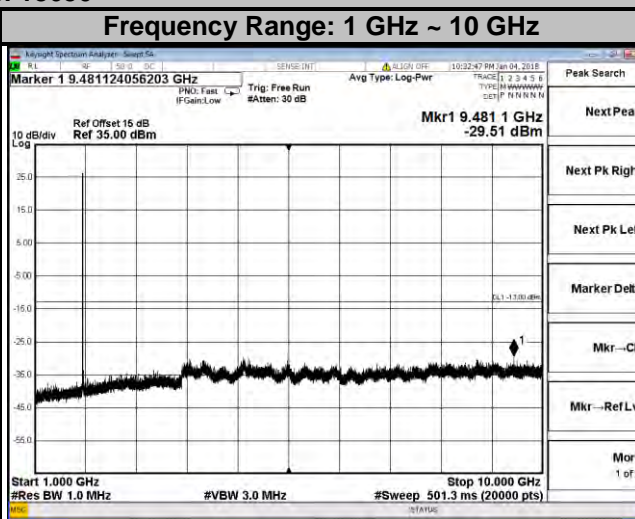
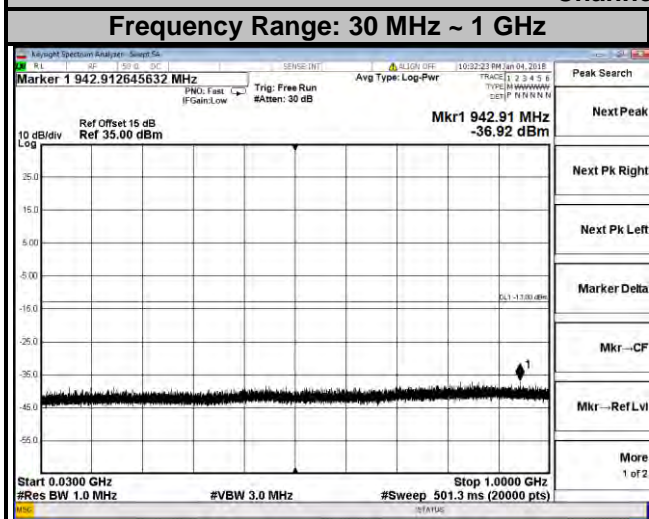

LTE Band 2
Channel Bandwidth: 10 MHz
Channel 18900

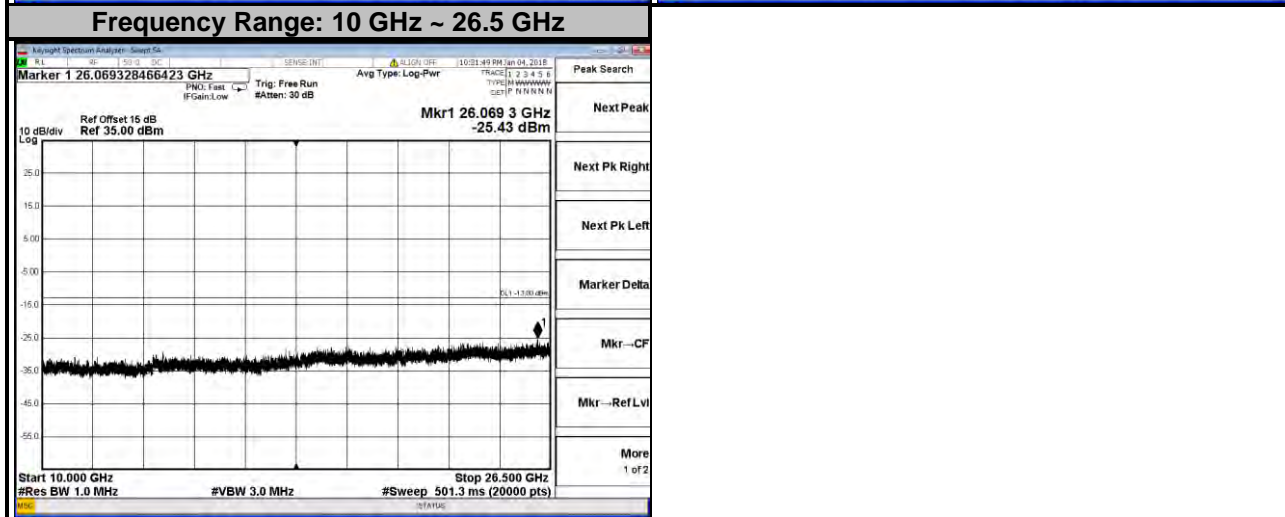
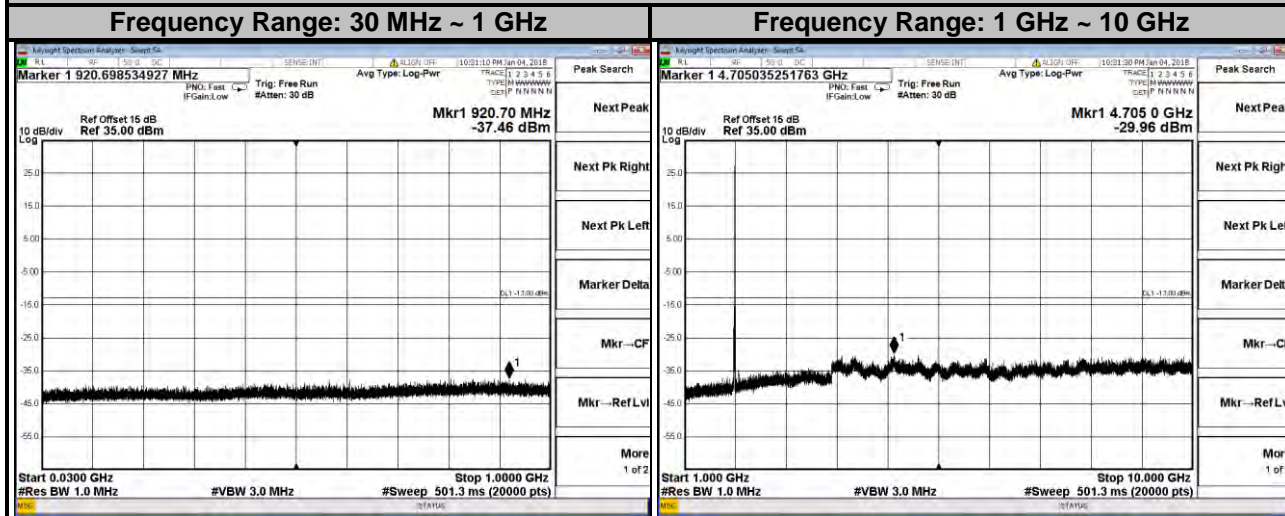

LTE Band 2
Channel Bandwidth: 10 MHz
Channel 19150

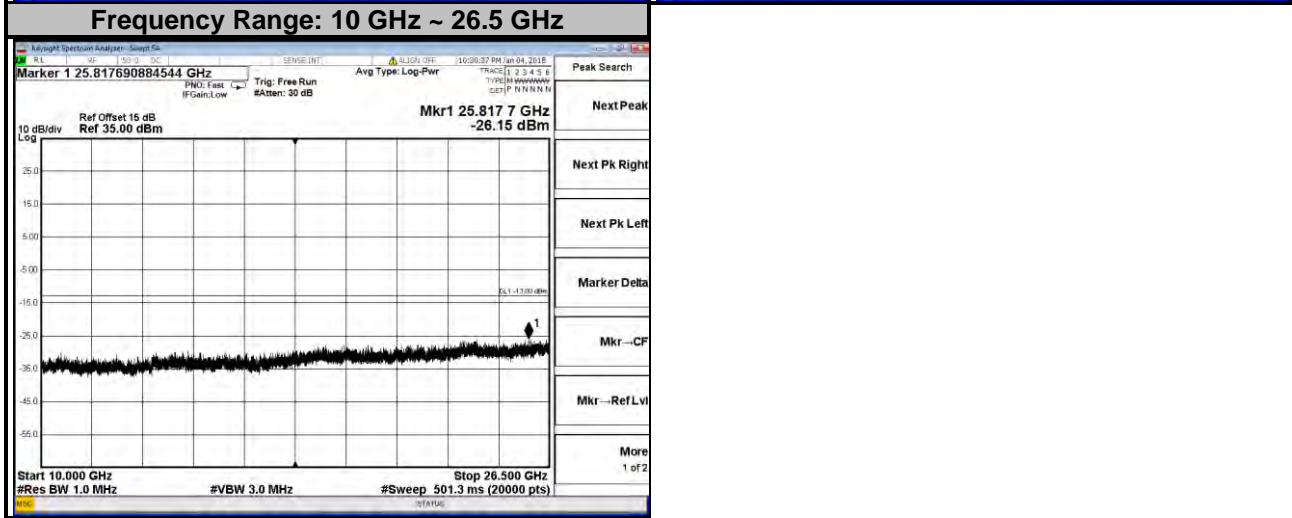
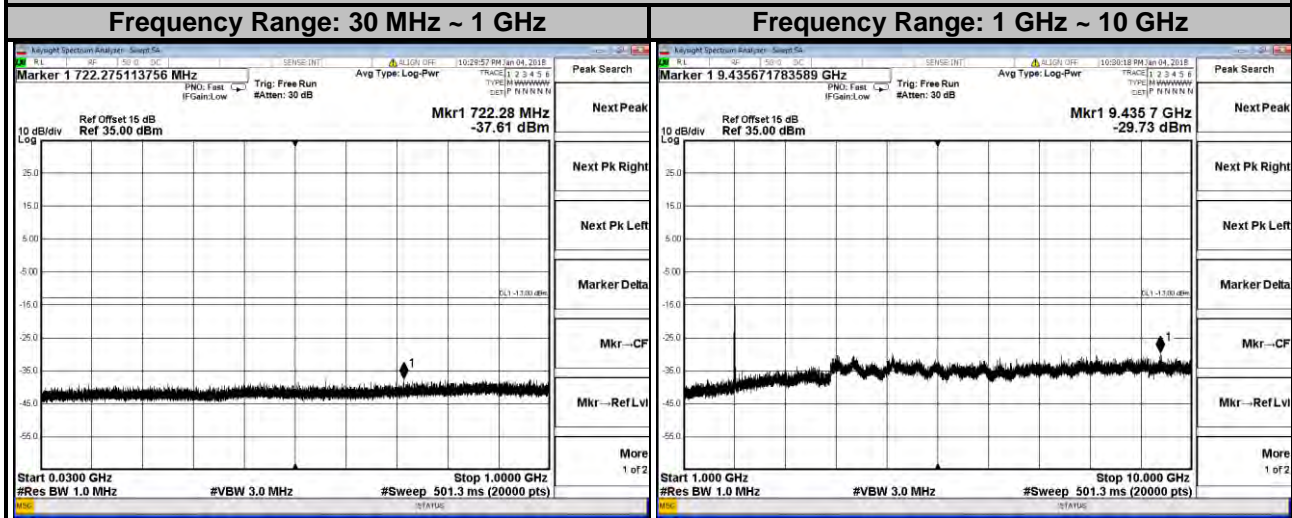

LTE Band 2
Channel Bandwidth: 15 MHz
Channel 18675

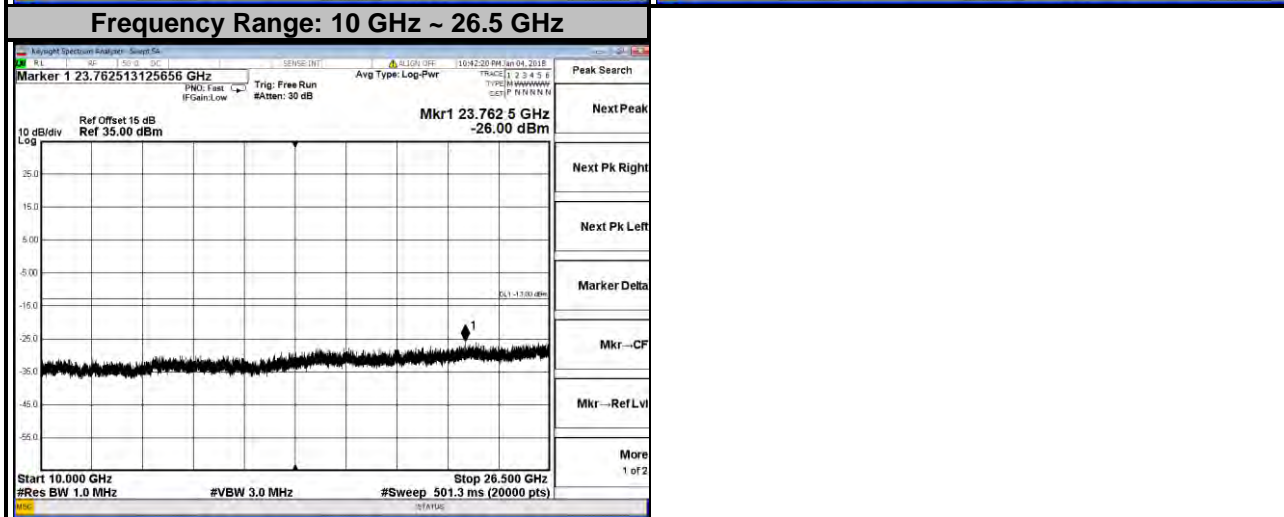
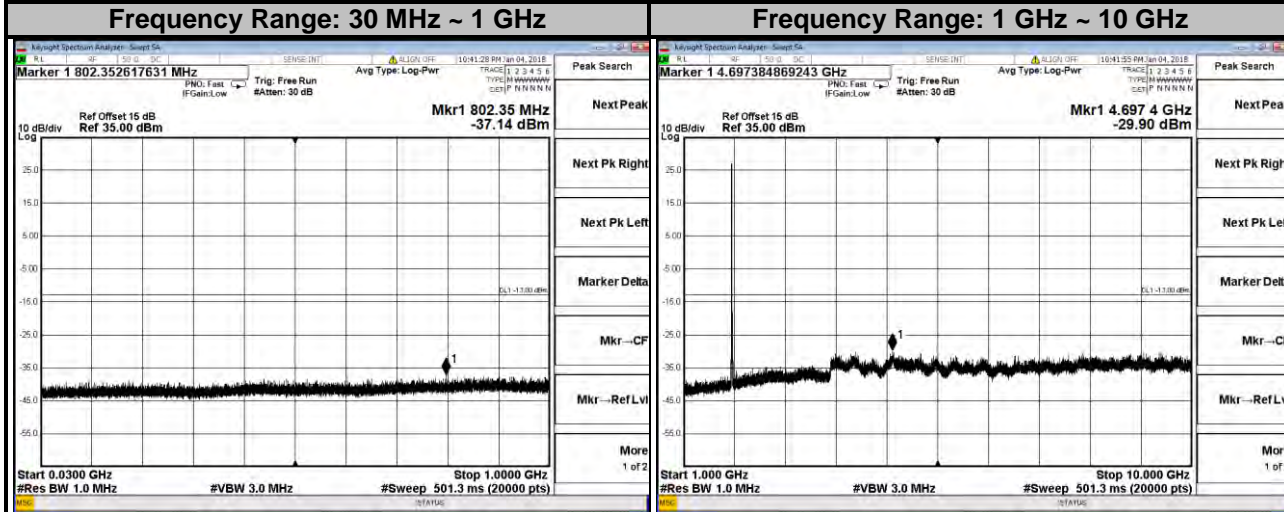

LTE Band 2
Channel Bandwidth: 15 MHz
Channel 18900

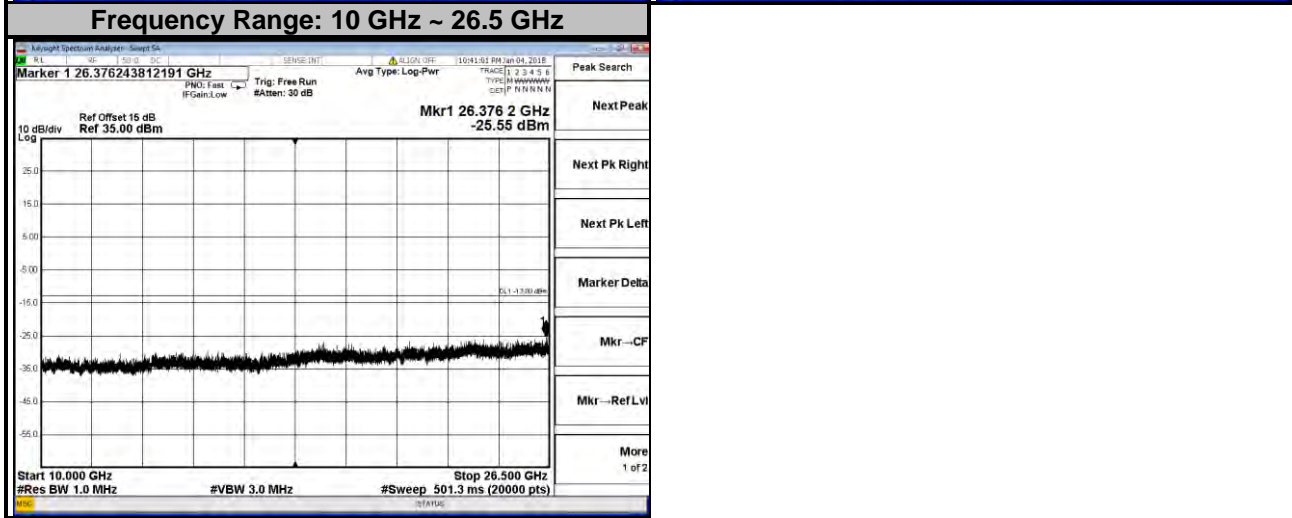
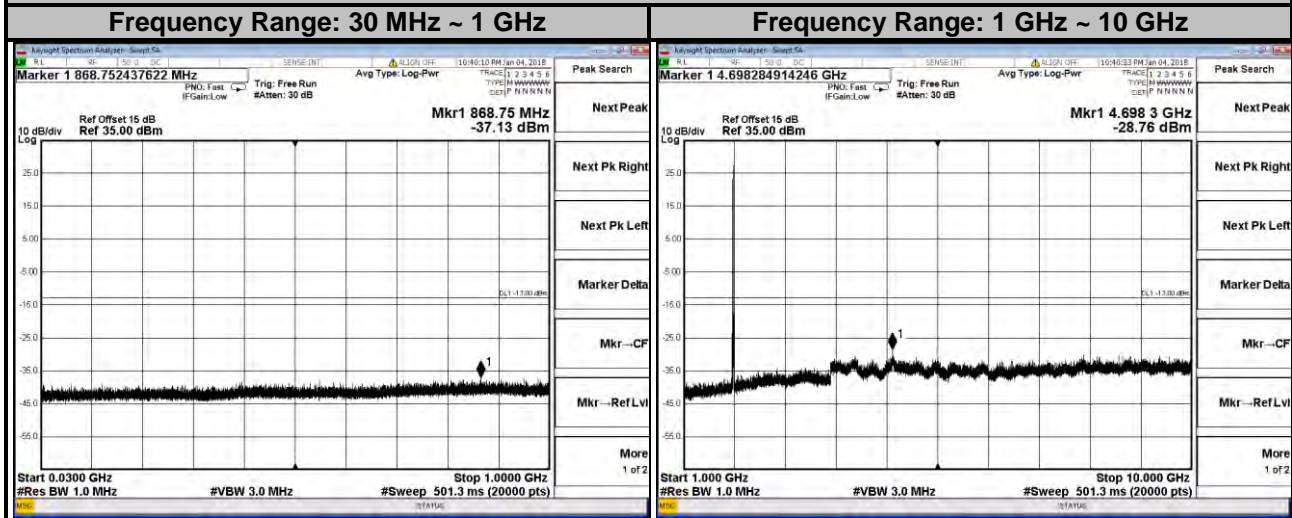

LTE Band 2
Channel Bandwidth: 15 MHz
Channel 19125

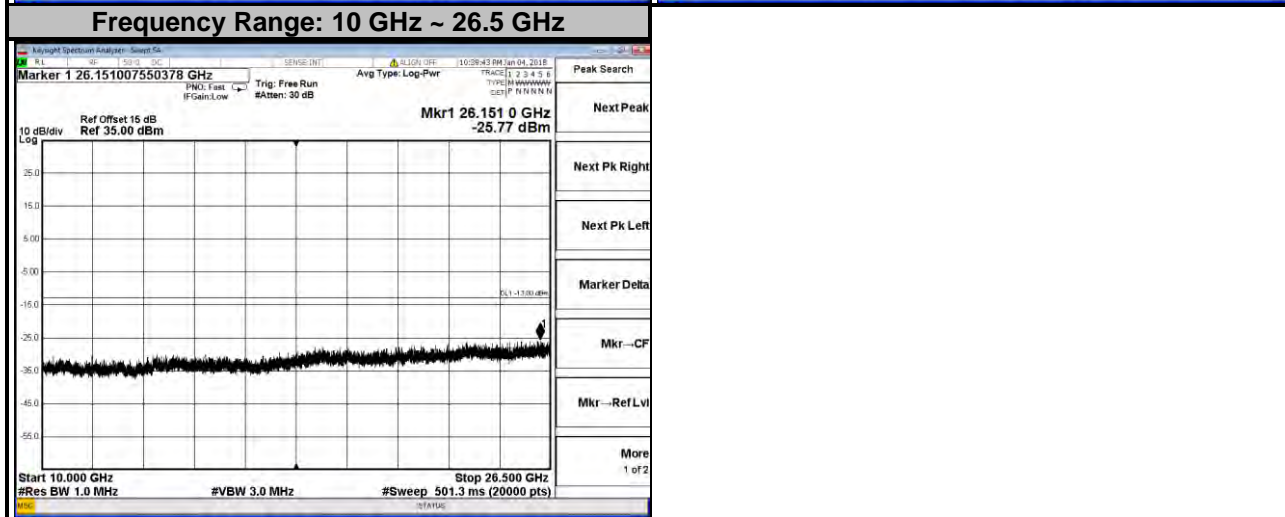
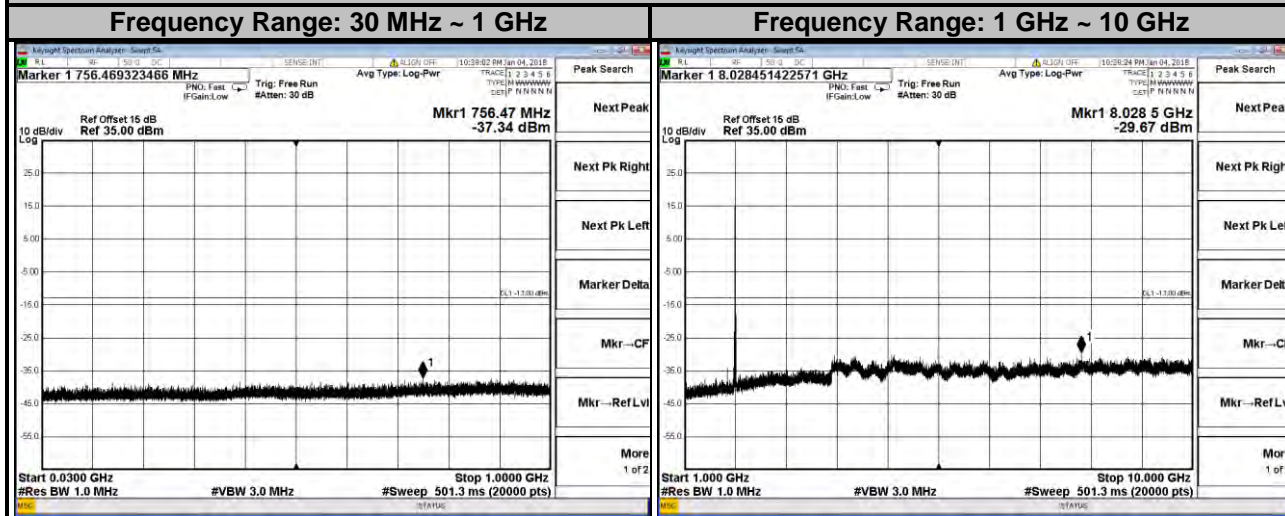

LTE Band 2
Channel Bandwidth: 20 MHz
Channel 18700

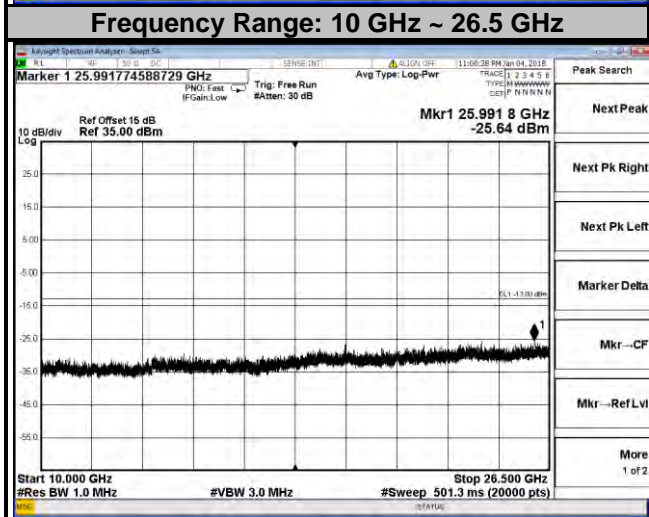
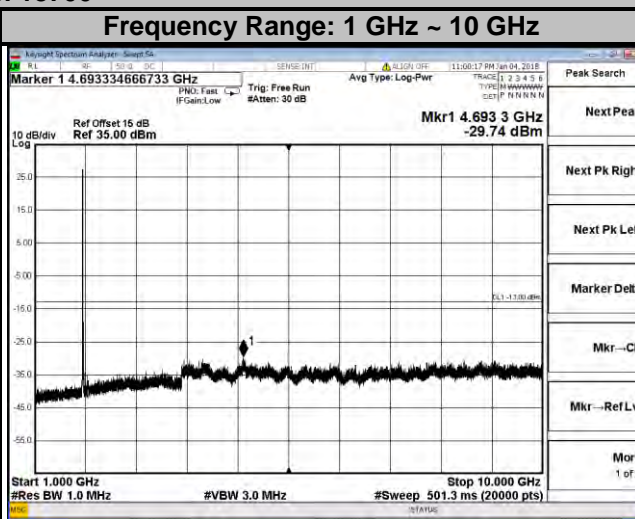
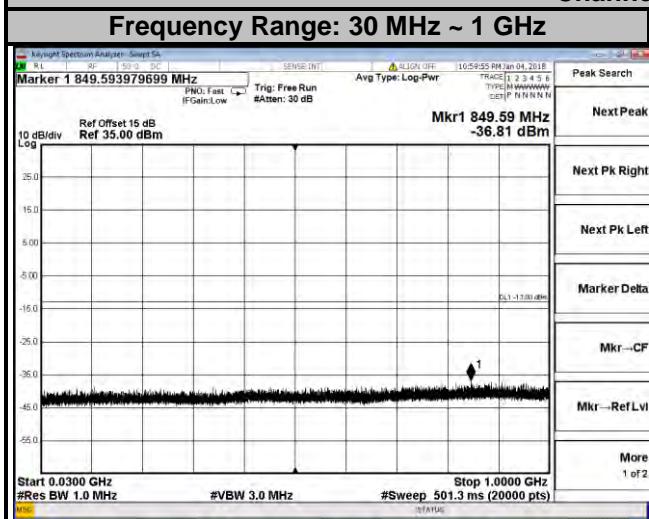

LTE Band 2
Channel Bandwidth: 20 MHz
Channel 18900

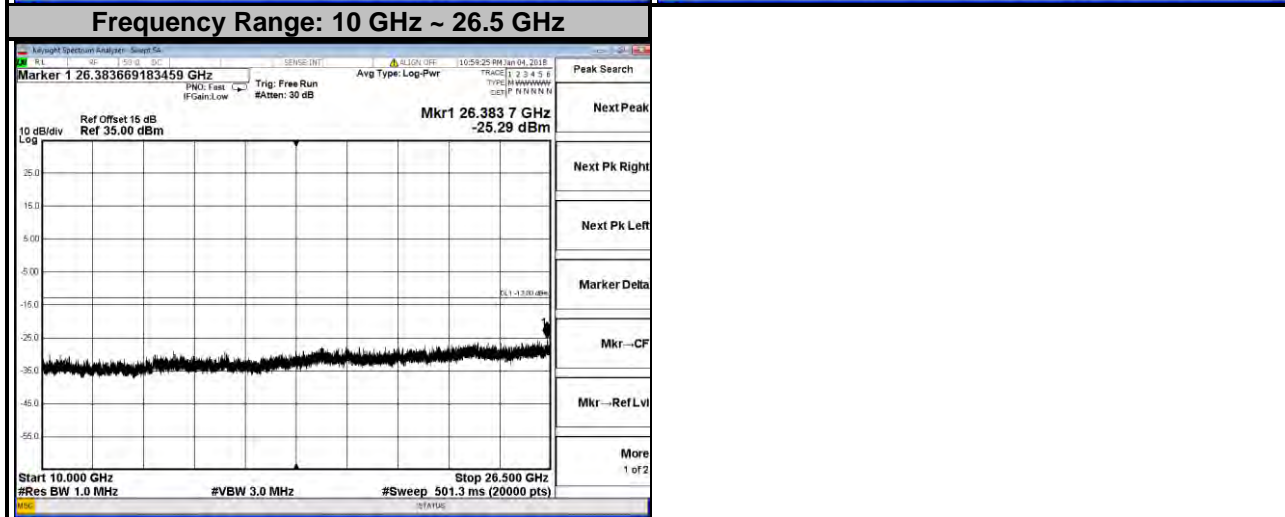
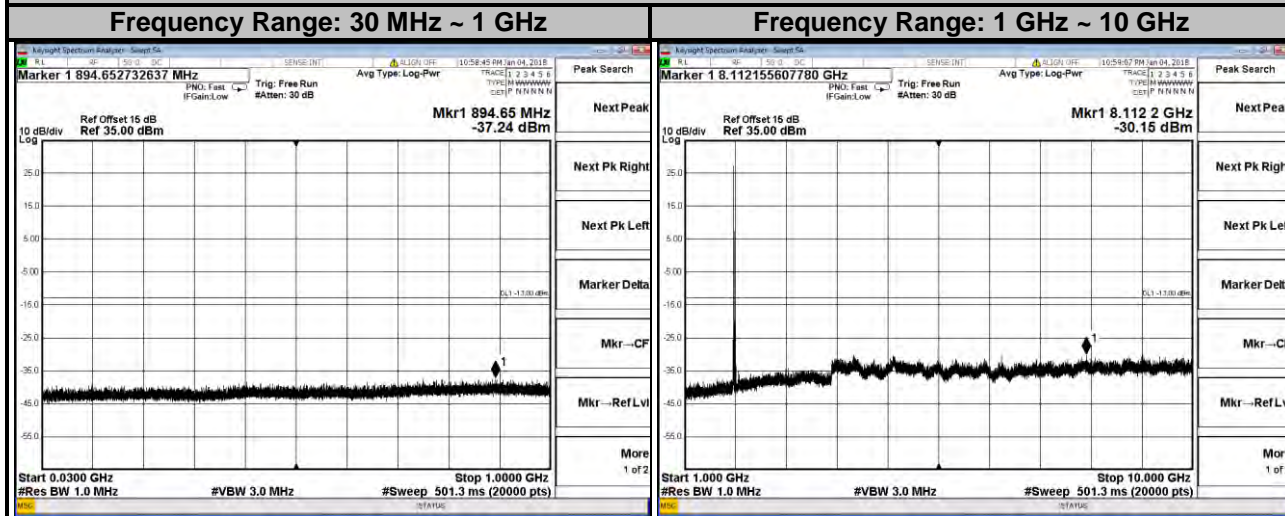

LTE Band 2
Channel Bandwidth: 20 MHz
Channel 19100

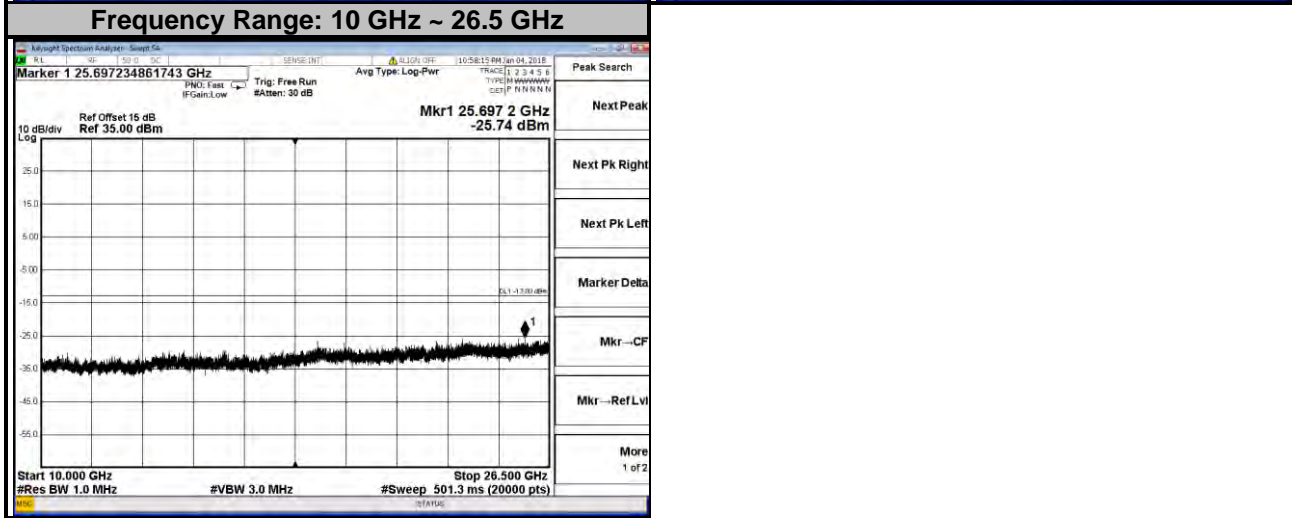
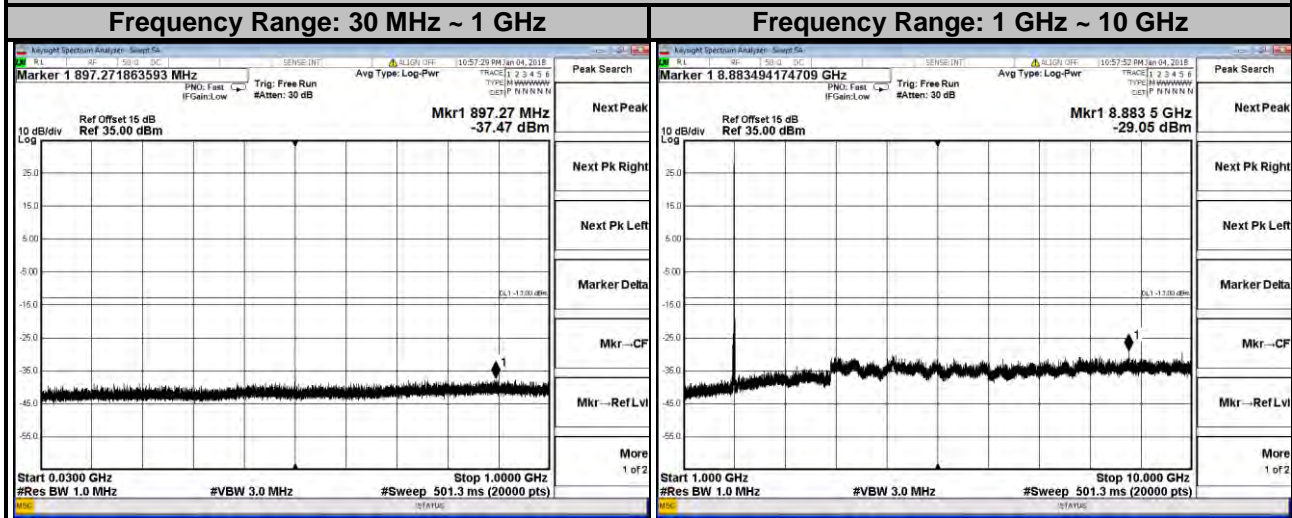

4.7 Radiated Emission Measurement

4.7.1 Limits of Radiated Emission Measurement

The power of any emission outside of the authorized operating frequency ranges must be attenuated below the transmitting power (P) by a factor of at least $43 + 10 \log(P)$ dB. The emission limit is equal to -13 dBm.

4.7.2 Test Procedure

- a. Substitution method is used for E.I.R.P measurement. In the semi-anechoic chamber, EUT placed on the 0.8 m (below or equal 1 GHz) and/or 1.5 m (above 1 GHz) height of Turn Table, rotated the table around 360 degrees to search the maximum radiation power and receiver antenna shall be rotated vertical and horizontal polarization and moved height from 1 m to 4 m to find the maximum polar radiated power. The "Read Value" is the spectrum reading the maximum power value.
- b. The substitution horn antenna is substituted for EUT at the same position and signals generator export the CW signal to the substitution antenna via a TX cable. Rotated the Turn Table and moved receiving antenna to find the maximum radiation power. Adjust output power level of S.G to get a Value of spectrum reading equal to "Read Value" of step a. Record the power level of S.G.
- c. EIRP = Output power level of S.G – TX cable loss + Antenna gain of substitution horn.
- d. E.R.P power can be calculated form E.I.R.P power by subtracting the gain of dipole, E.R.P power = E.I.P.R power - 2.15 dBi.

NOTE: The resolution bandwidth and video bandwidth of test receiver/spectrum analyzer is 1 MHz/3 MHz.

4.7.3 Deviation from Test Standard

No deviation.

4.7.4 Test Setup

<Radiated Emission below or equal 1 GHz>

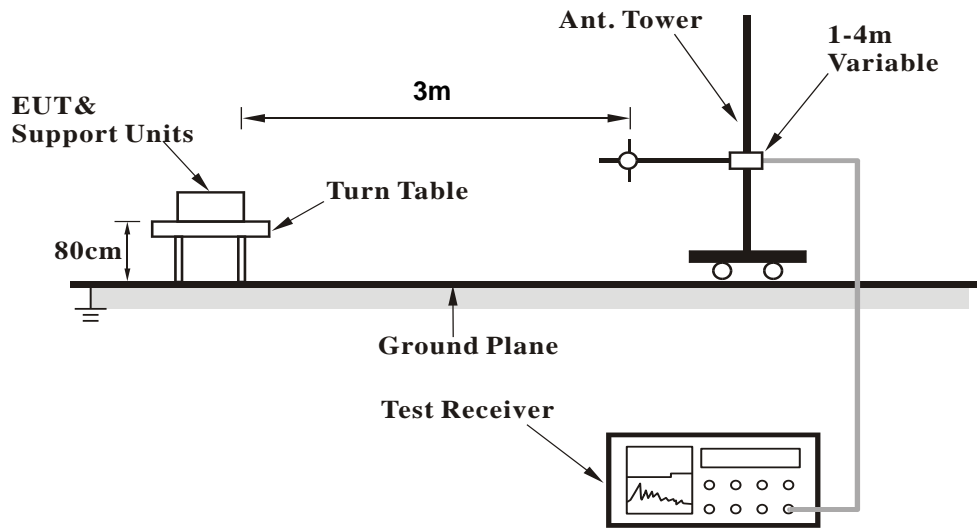

<Radiated Emission above 1 GHz>

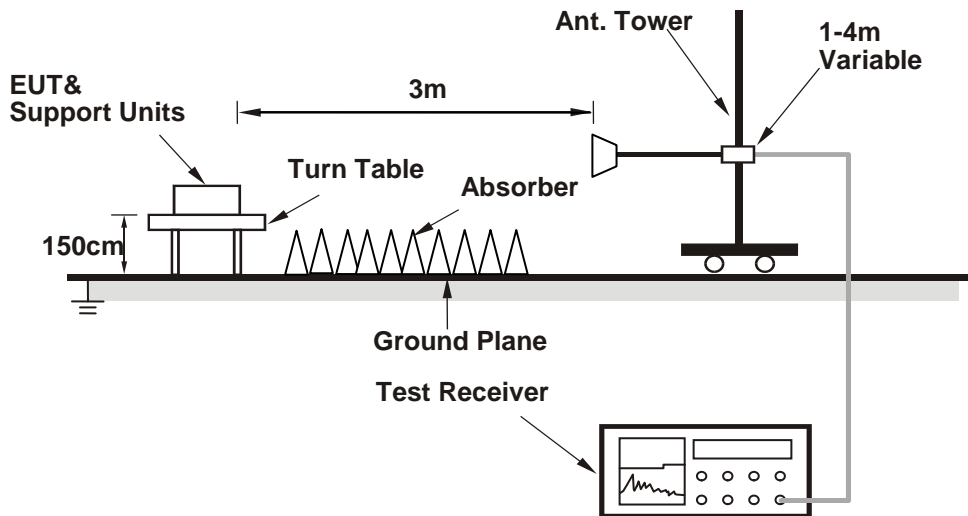

For the actual test configuration, please refer to the attached file (Test Setup Photo).

4.7.5 Test Results

GSM:

Low Channel



Bureau Veritas Consumer Products Services Ltd., Taoyuan Branch

A D T

Data: 9

Date: 2017-12-22

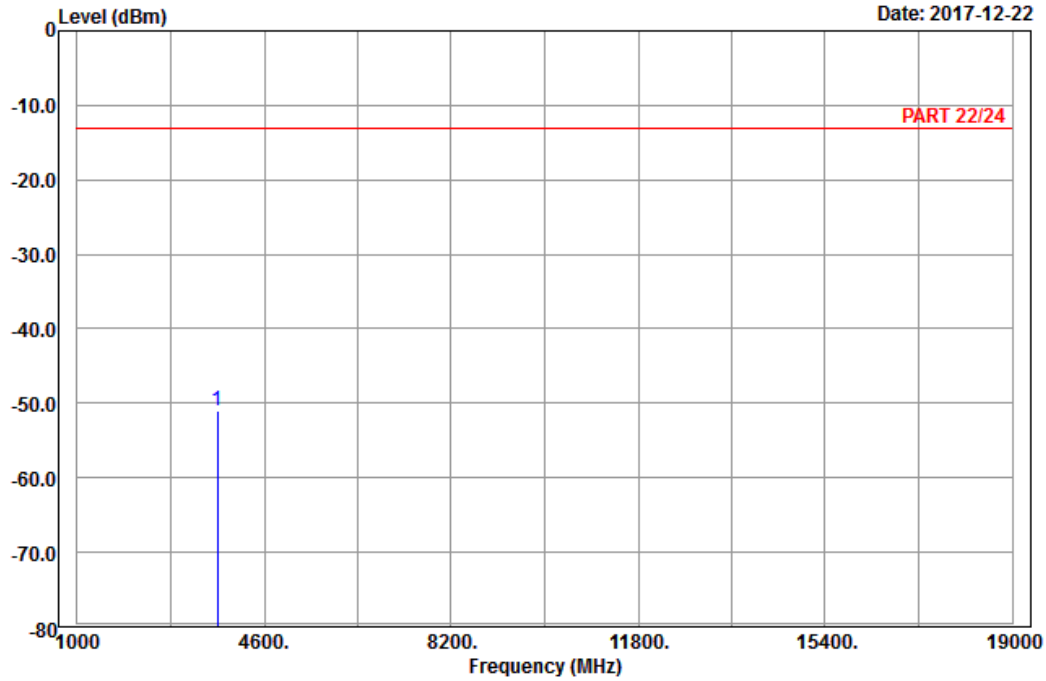

Site : 966 chamber 1
 Condition: PART 22/24 Horizontal
 Remark : PCS 1900_Link_CH512
 Tested by: Karl Lee

	Freq	Level	Read Level	Limit Line	Over Limit	Factor	Remark
	MHz	dBm	dBm	dBm	dB	dB	
1	pp 3700.40	-50.93	-66.81	-13.00	-37.93	15.88	Peak



Bureau Veritas Consumer Products Services Ltd., Taoyuan Branch

A D T

Data: 10

Date: 2017-12-22

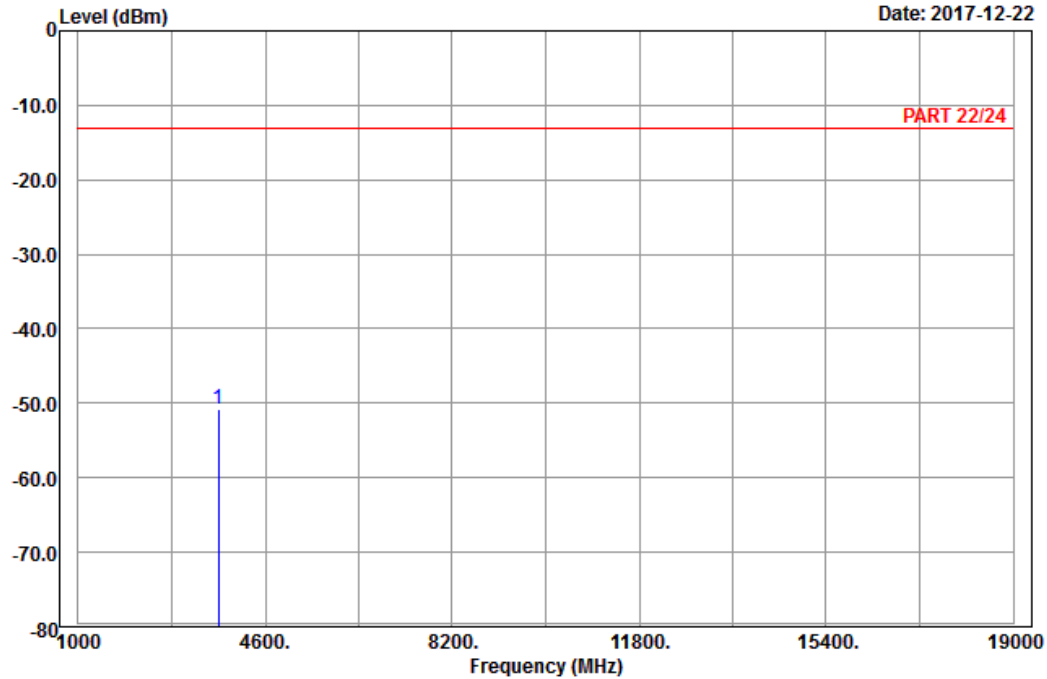

Site : 966 chamber 1
 Condition: PART 22/24 Vertical
 Remark : PCS 1900_Link_CH512
 Tested by: Karl Lee

	Freq	Level	Read Level	Limit Line	Over Limit	Factor	Remark
	MHz	dBm	dBm	dBm	dB	dB	
1	pp 3700.40	-50.71	-66.59	-13.00	-37.71	15.88	Peak

Middle Channel



Bureau Veritas Consumer Products Services Ltd., Taoyuan Branch

A D T

Data: 9

Date: 2017-12-22

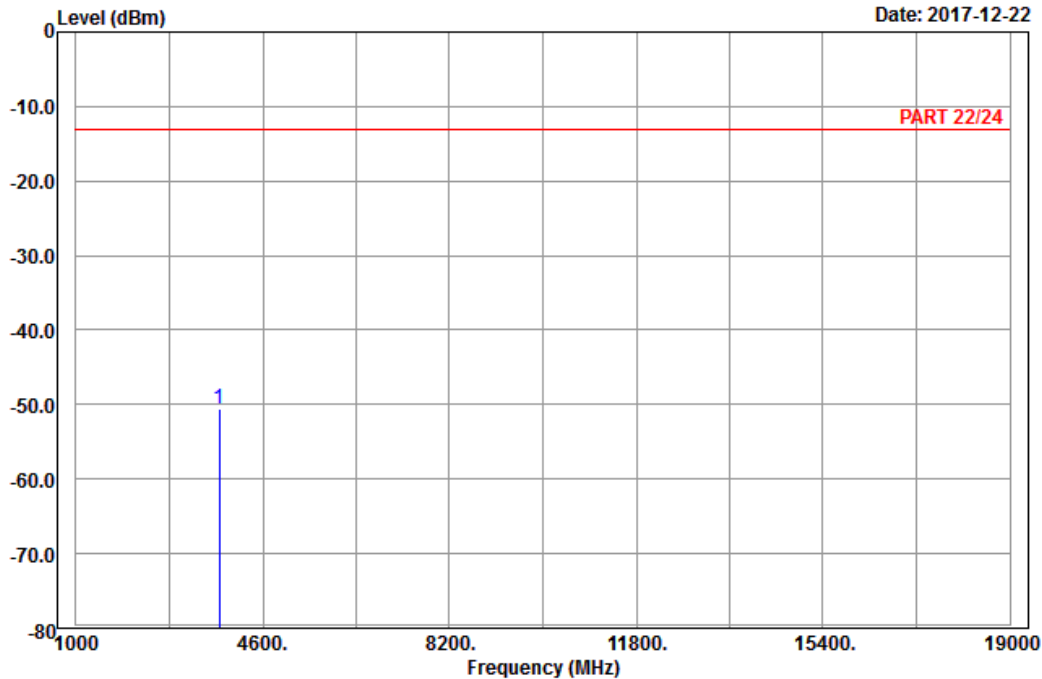

Site : 966 chamber 1
 Condition: PART 22/24 Horizontal
 Remark : PCS 1900_Link_CH661
 Tested by: Karl Lee

Freq	Level	Read Level	Limit Line	Over Limit	Factor	Remark
MHz	dBm	dBm	dBm	dB	dB	
1 pp 3760.00	-50.56	-66.70	-13.00	-37.56	16.14	Peak



Bureau Veritas Consumer Products Services Ltd., Taoyuan Branch

A D T

Data: 10

Date: 2017-12-22

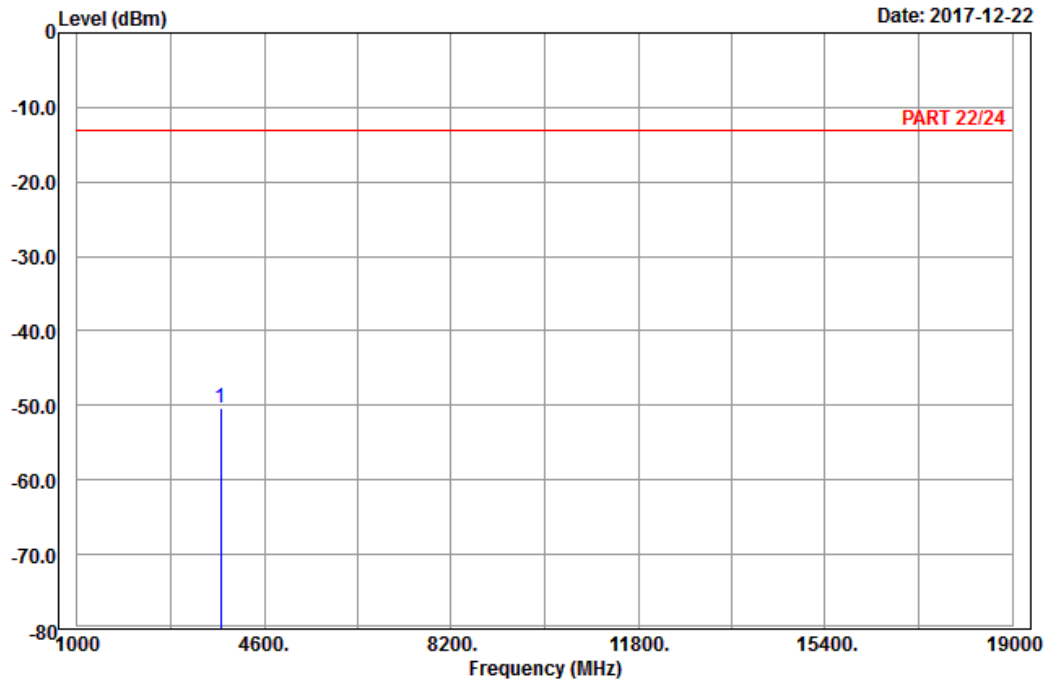

Site : 966 chamber 1
 Condition: PART 22/24 Vertical
 Remark : PCS 1900_Link_CH661
 Tested by: Karl Lee

	Freq	Level	Read Level	Limit Line	Over Limit	Factor	Remark
	MHz	dBm	dBm	dBm	dB	dB	
1	pp 3760.00	-50.41	-66.55	-13.00	-37.41	16.14	Peak

High Channel



Bureau Veritas Consumer Products Services Ltd., Taoyuan Branch

A D T

Data: 13

Date: 2017-12-22

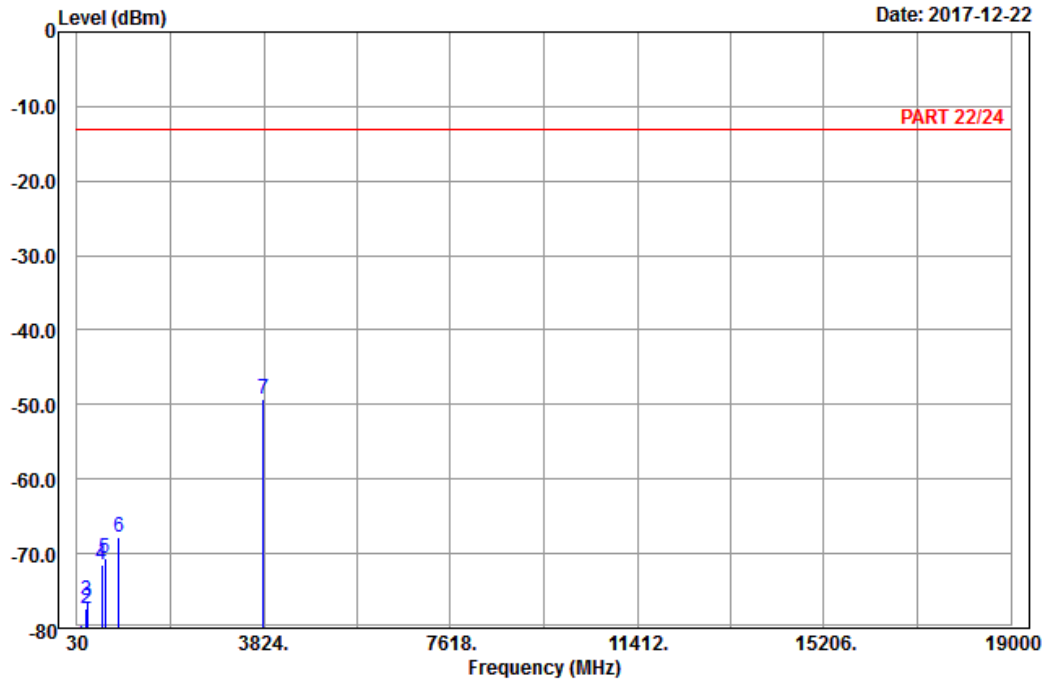

Site : 966 chamber 1
 Condition: PART 22/24 Horizontal
 Remark : PCS 1900_Link_CH810
 Tested by: Karl Lee

	Freq	Level	Read Level	Limit Line	Over Limit	Factor	Remark
	MHz	dBm	dBm	dBm	dB	dB	
1	101.55	-82.31	-72.42	-13.00	-69.31	-9.89	Peak
2	224.94	-77.32	-71.47	-13.00	-64.32	-5.85	Peak
3	241.68	-76.39	-70.77	-13.00	-63.39	-5.62	Peak
4	532.40	-71.59	-68.65	-13.00	-58.59	-2.94	Peak
5	601.70	-70.53	-70.95	-13.00	-57.53	0.42	Peak
6	881.00	-67.81	-70.14	-13.00	-54.81	2.33	Peak
7 pp	3819.60	-49.36	-65.86	-13.00	-36.36	16.50	Peak



Bureau Veritas Consumer Products Services Ltd., Taoyuan Branch

A D T

Data: 14

Date: 2017-12-22

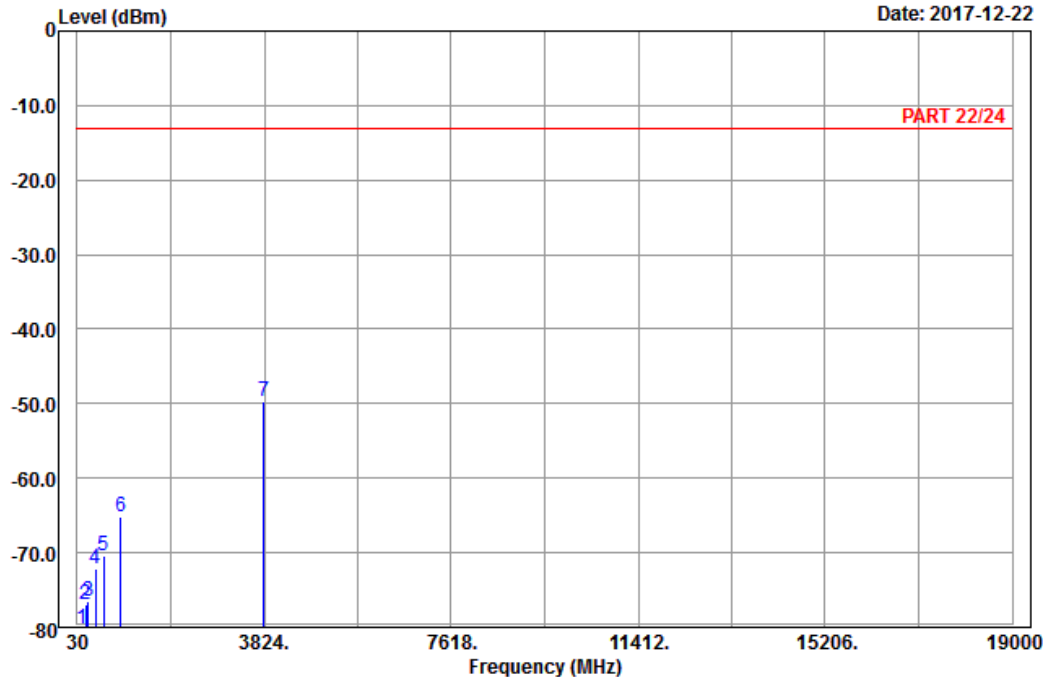

Site : 966 chamber 1
 Condition: PART 22/24 Vertical
 Remark : PCS 1900_Link_CH810
 Tested by: Karl Lee

	Freq	Level	Read Level	Limit Line	Over Limit	Factor	Remark
	MHz	dBm	dBm	dBm	dB	dB	
1	121.26	-80.29	-72.10	-13.00	-67.29	-8.19	Peak
2	203.07	-76.95	-70.81	-13.00	-63.95	-6.14	Peak
3	245.19	-76.49	-70.92	-13.00	-63.49	-5.57	Peak
4	407.10	-72.23	-69.32	-13.00	-59.23	-2.91	Peak
5	561.80	-70.44	-69.26	-13.00	-57.44	-1.18	Peak
6	919.50	-65.23	-68.99	-13.00	-52.23	3.76	Peak
7 pp	3819.60	-49.69	-66.19	-13.00	-36.69	16.50	Peak

EDGE:
Low Channel



Bureau Veritas Consumer Products Services Ltd., Taoyuan Branch

A D T

Data: 9

Date: 2017-12-22

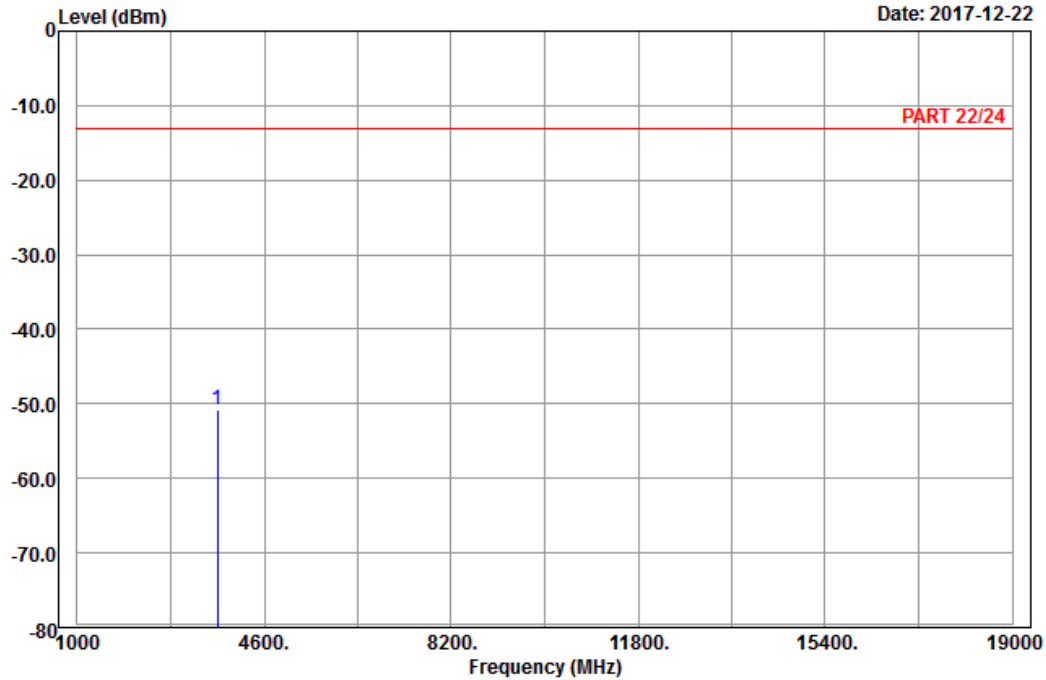

Site : 966 chamber 1
Condition: PART 22/24 Horizontal
Remark : EDGE 1900_Link_CH512
Tested by: Karl Lee

	Read	Limit	Over			
Freq	Level	Level	Line	Limit	Factor	Remark
MHz	dBm	dBm	dBm	dB	dB	
1 pp 3700.40	-50.75	-66.63	-13.00	-37.75	15.88	Peak



Bureau Veritas Consumer Products Services Ltd., Taoyuan Branch

A D T

Data: 10

Date: 2017-12-22

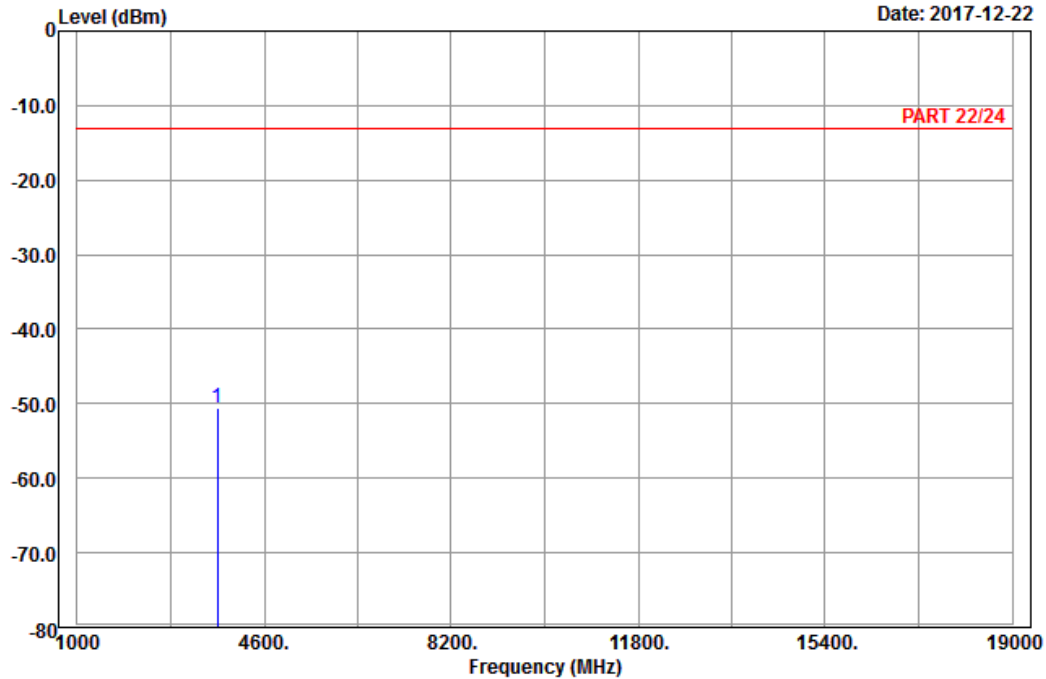

Site : 966 chamber 1
 Condition: PART 22/24 Vertical
 Remark : EDGE 1900_Link_CH512
 Tested by: Karl Lee

	Freq	Level	Read Level	Limit Line	Over Limit	Factor	Remark
	MHz	dBm	dBm	dBm	dB	dB	
1	pp 3700.40	-50.50	-66.38	-13.00	-37.50	15.88	Peak

Middle Channel



Bureau Veritas Consumer Products Services Ltd., Taoyuan Branch

A D T

Data: 9

Date: 2017-12-22

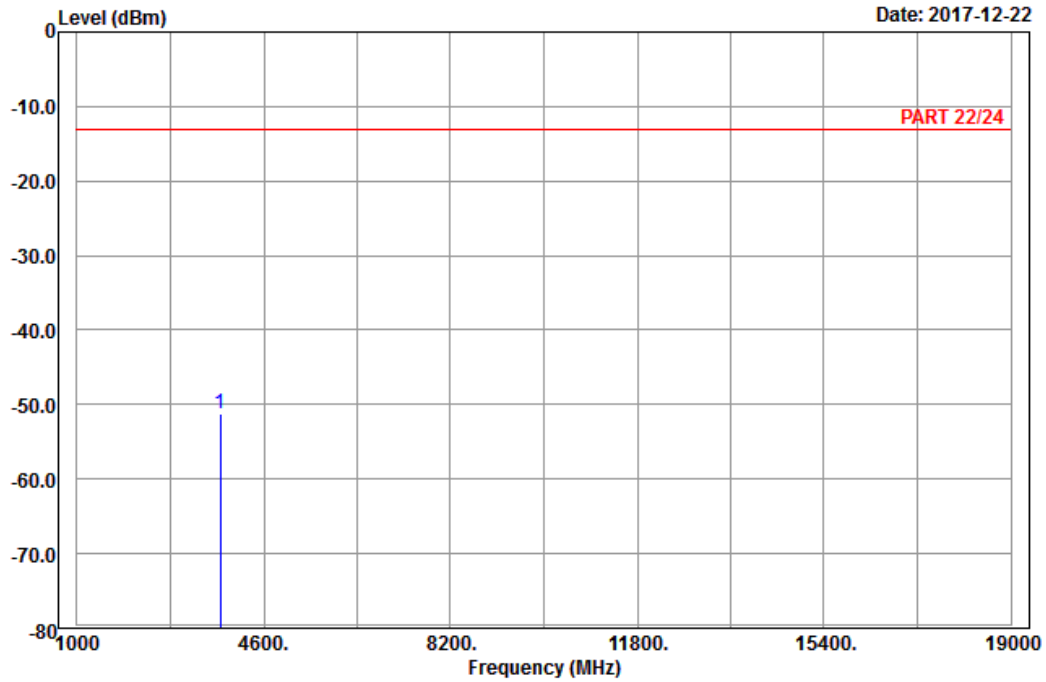

Site : 966 chamber 1
 Condition: PART 22/24 Horizontal
 Remark : EDGE 1900_Link_CH661
 Tested by: Karl Lee

Freq	Level	Read Level	Limit Line	Over Limit	Factor	Remark
MHz	dBm	dBm	dBm	dB	dB	
1 pp 3760.00	-51.30	-67.44	-13.00	-38.30	16.14	Peak



Bureau Veritas Consumer Products Services Ltd., Taoyuan Branch

A D T

Data: 10

Date: 2017-12-22

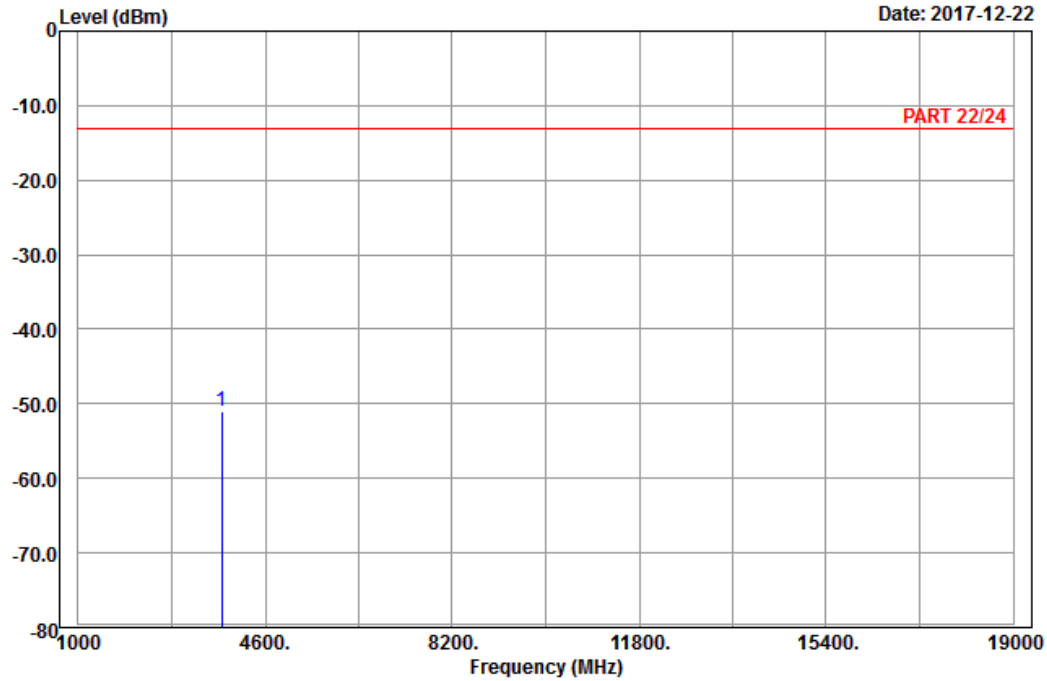

Site : 966 chamber 1
 Condition: PART 22/24 Vertical
 Remark : EDGE 1900_Link_CH661
 Tested by: Karl Lee

	Freq	Level	Read Level	Limit Line	Over Limit	Factor	Remark
	MHz	dBm	dBm	dBm	dB	dB	
1	pp 3760.00	-51.11	-67.25	-13.00	-38.11	16.14	Peak

High Channel



Bureau Veritas Consumer Products Services Ltd., Taoyuan Branch

A D T

Data: 9

Date: 2017-12-22

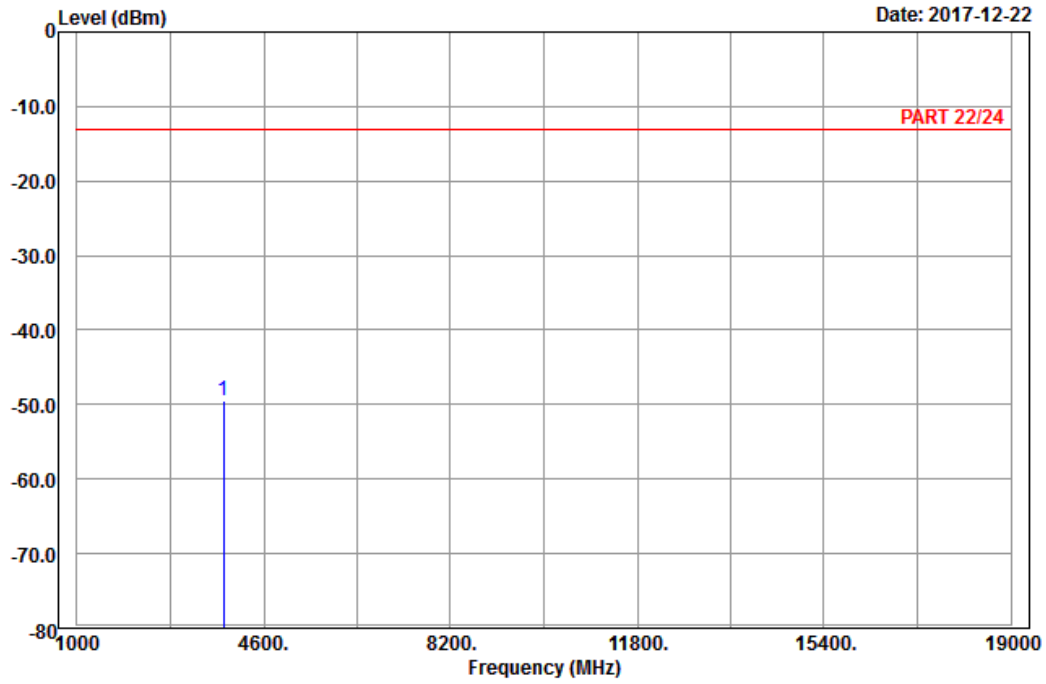

Site : 966 chamber 1
 Condition: PART 22/24 Horizontal
 Remark : EDGE 1900_Link_CH810
 Tested by: Karl Lee

	Freq	Level	Read Level	Limit Line	Over Limit	Factor	Remark
	MHz	dBm	dBm	dBm	dB	dB	
1	pp 3819.60	-49.49	-65.99	-13.00	-36.49	16.50	Peak



Bureau Veritas Consumer Products Services Ltd., Taoyuan Branch

A D T

Data: 10

Date: 2017-12-22

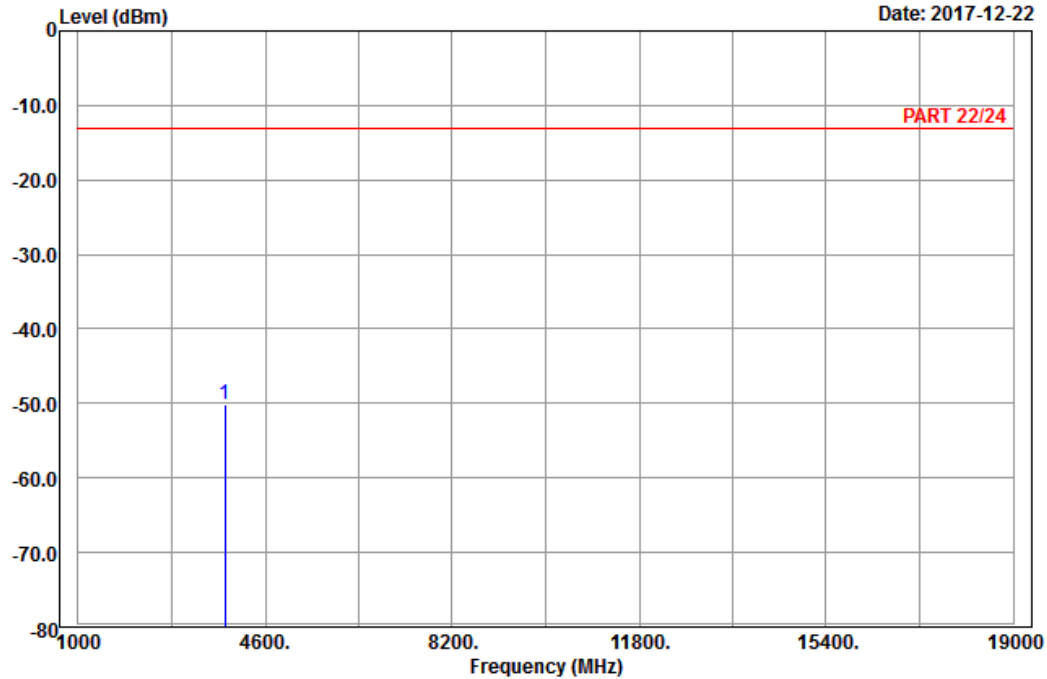

Site : 966 chamber 1
 Condition: PART 22/24 Vertical
 Remark : EDGE 1900_Link_CH810
 Tested by: Karl Lee

	Freq	Level	Read Level	Limit Line	Over Limit	Factor	Remark
	MHz	dBm	dBm	dBm	dB	dB	
1	pp 3819.60	-50.12	-66.62	-13.00	-37.12	16.50	Peak

WCDMA:
Low Channel



Bureau Veritas Consumer Products Services Ltd., Taoyuan Branch

A D T

Data: 9

Date: 2017-12-22

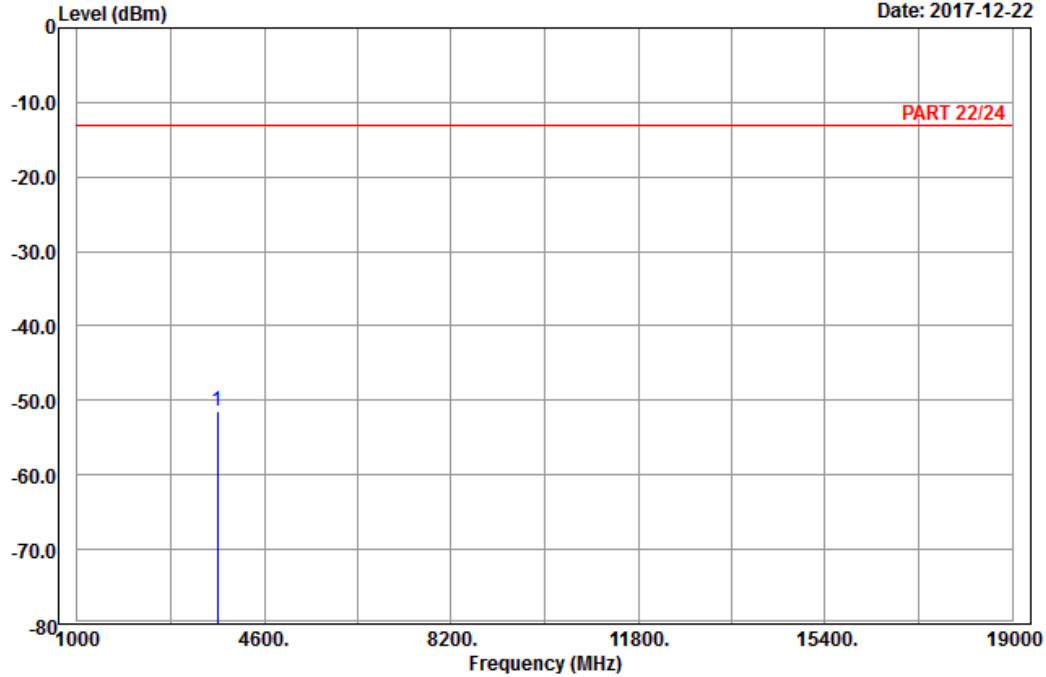

Site : 966 chamber 1
Condition: PART 22/24 Horizontal
Remark : Band II_Link_CH9400
Tested by: Karl Lee

	Freq	Level	Read Level	Limit Line	Over Limit	Factor	Remark
	MHz	dBm	dBm	dBm	dB	dB	
1	pp 3704.80	-51.44	-67.32	-13.00	-38.44	15.88	Peak



Bureau Veritas Consumer Products Services Ltd., Taoyuan Branch

A D T

Data: 10

Date: 2017-12-22

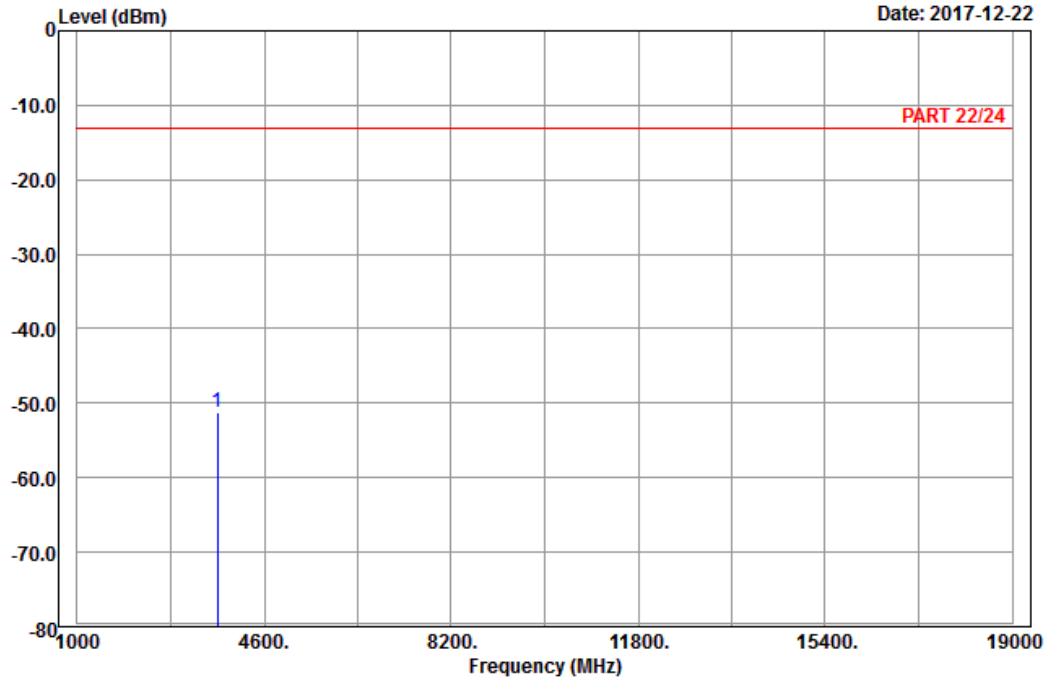

Site : 966 chamber 1
 Condition: PART 22/24 Vertical
 Remark : Band II_Link_CH9400
 Tested by: Karl Lee

	Freq	Level	Read Level	Limit Line	Over Limit	Factor	Remark
	MHz	dBm	dBm	dBm	dB	dB	
1	pp 3704.80	-51.13	-67.01	-13.00	-38.13	15.88	Peak

Middle Channel



Bureau Veritas Consumer Products Services Ltd., Taoyuan Branch

A D T

Data: 9

Date: 2017-12-22

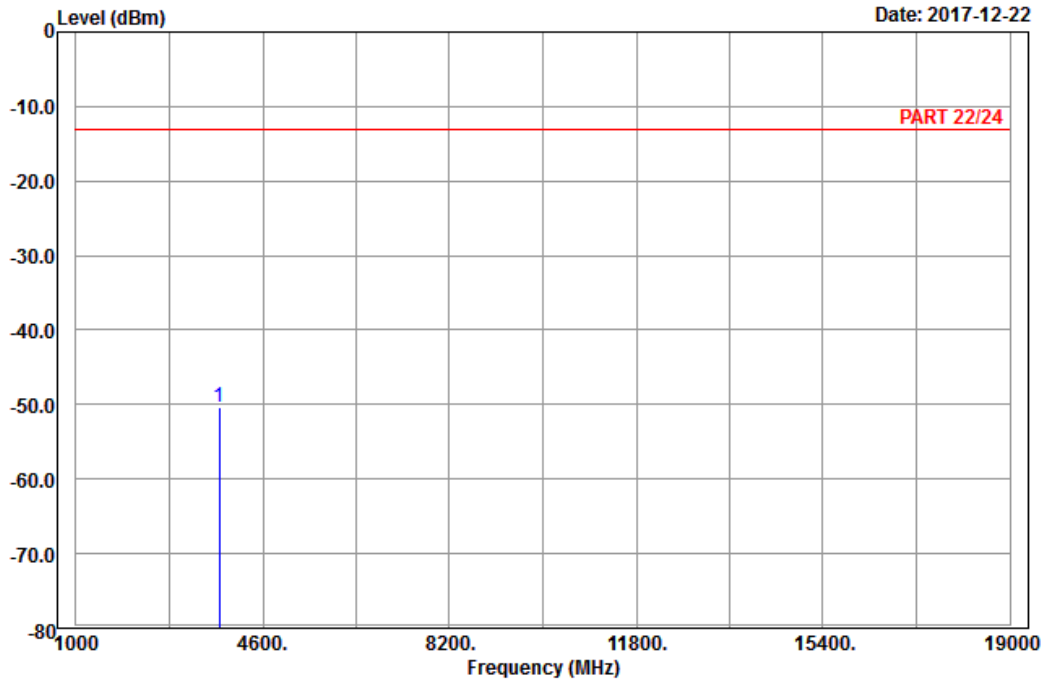

Site : 966 chamber 1
 Condition: PART 22/24 Horizontal
 Remark : Band II_Link_CH9400
 Tested by: Karl Lee

Freq	Level	Read Level	Limit Line	Over Limit	Factor	Remark
MHz	dBm	dBm	dBm	dB	dB	
1 pp 3760.00	-50.41	-66.55	-13.00	-37.41	16.14	Peak



Bureau Veritas Consumer Products Services Ltd., Taoyuan Branch

A D T

Data: 10

Date: 2017-12-22

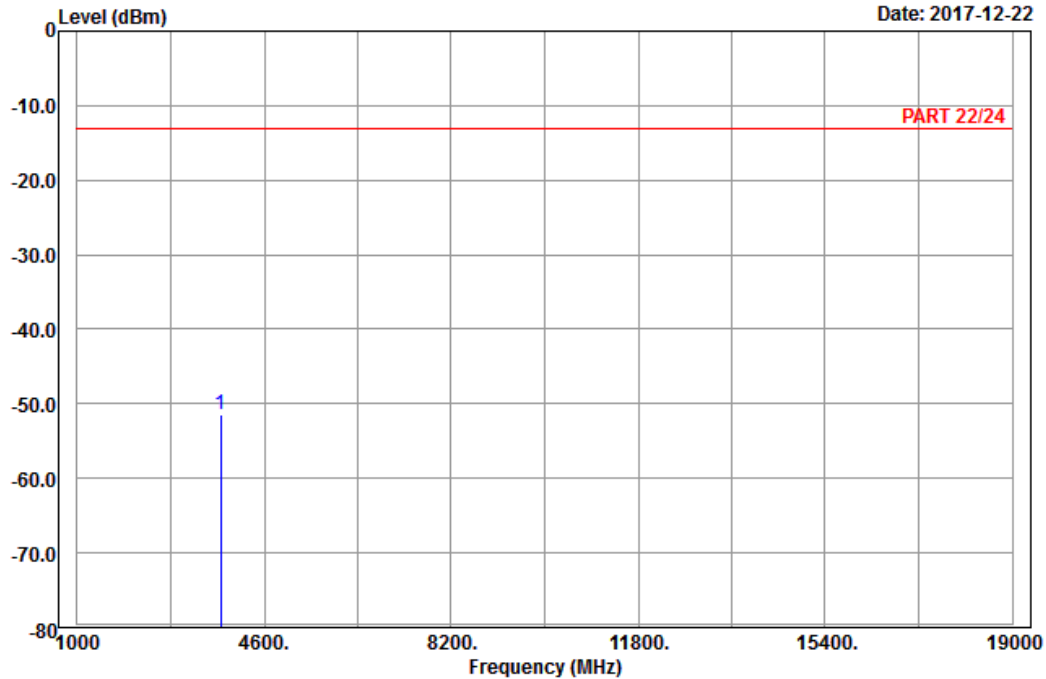

Site : 966 chamber 1
 Condition: PART 22/24 Vertical
 Remark : Band II_Link_CH9400
 Tested by: Karl Lee

	Freq	Level	Read Level	Limit Line	Over Limit	Factor	Remark
	MHz	dBm	dBm	dBm	dB	dB	
1	pp 3760.00	-51.49	-67.63	-13.00	-38.49	16.14	Peak

High Channel



Bureau Veritas Consumer Products Services Ltd., Taoyuan Branch

A D T

Data: 9

Date: 2017-12-22

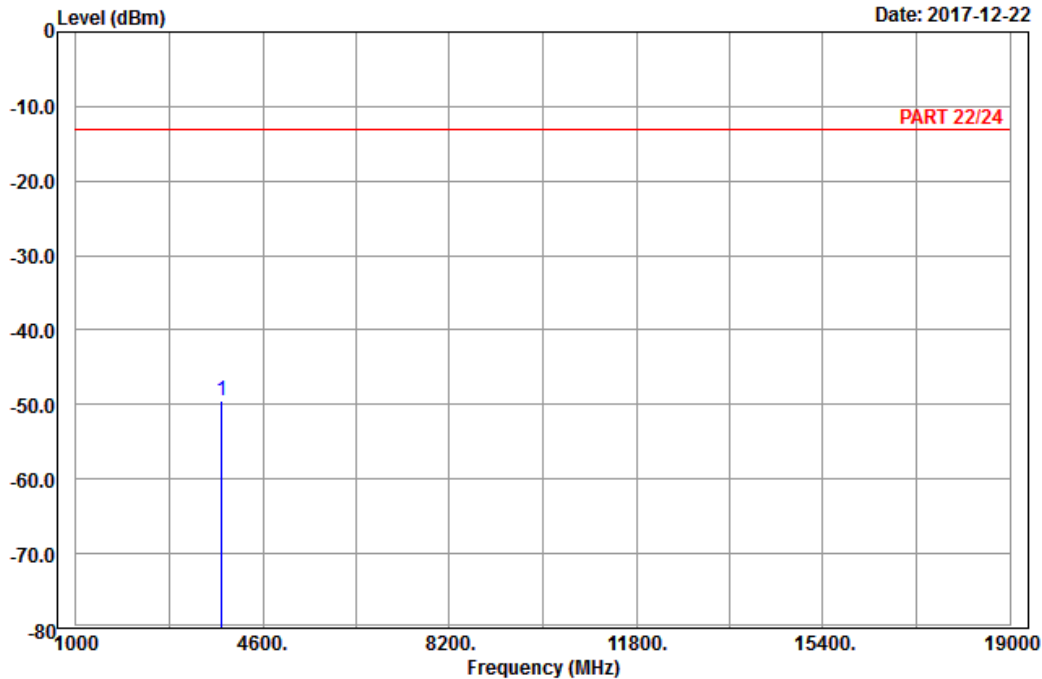

Site : 966 chamber 1
 Condition: PART 22/24 Horizontal
 Remark : Band II_Link_CH9400
 Tested by: Karl Lee

Freq	Level	Read Level	Limit Line	Over Limit	Factor	Remark
MHz	dBm	dBm	dBm	dB	dB	
1 pp 3815.20	-49.52	-65.93	-13.00	-36.52	16.41	Peak



Bureau Veritas Consumer Products Services Ltd., Taoyuan Branch

A D T

Data: 10

Date: 2017-12-22

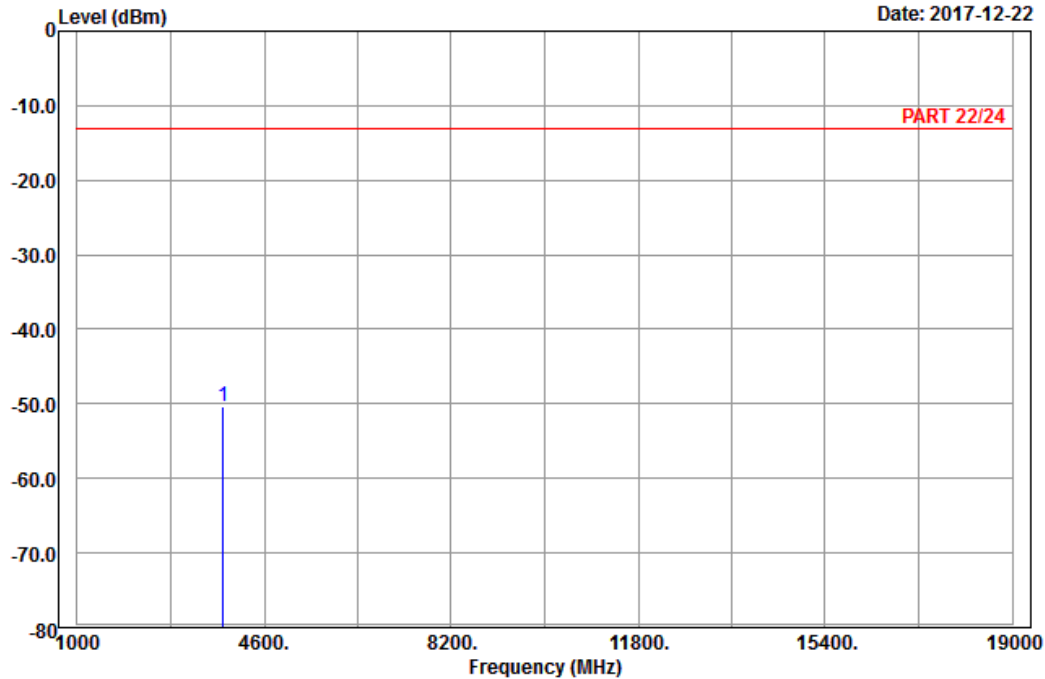

Site : 966 chamber 1
 Condition: PART 22/24 Vertical
 Remark : Band II_Link_CH9400
 Tested by: Karl Lee

	Freq	Level	Read Level	Limit Line	Over Limit	Factor	Remark
	MHz	dBm	dBm	dBm	dB	dB	
1	pp 3815.20	-50.32	-66.73	-13.00	-37.32	16.41	Peak

LTE Band 2
Channel Bandwidth: 20 MHz / QPSK
Low Channel



Bureau Veritas Consumer Products Services Ltd., Taoyuan Branch

A D T

Data: 13

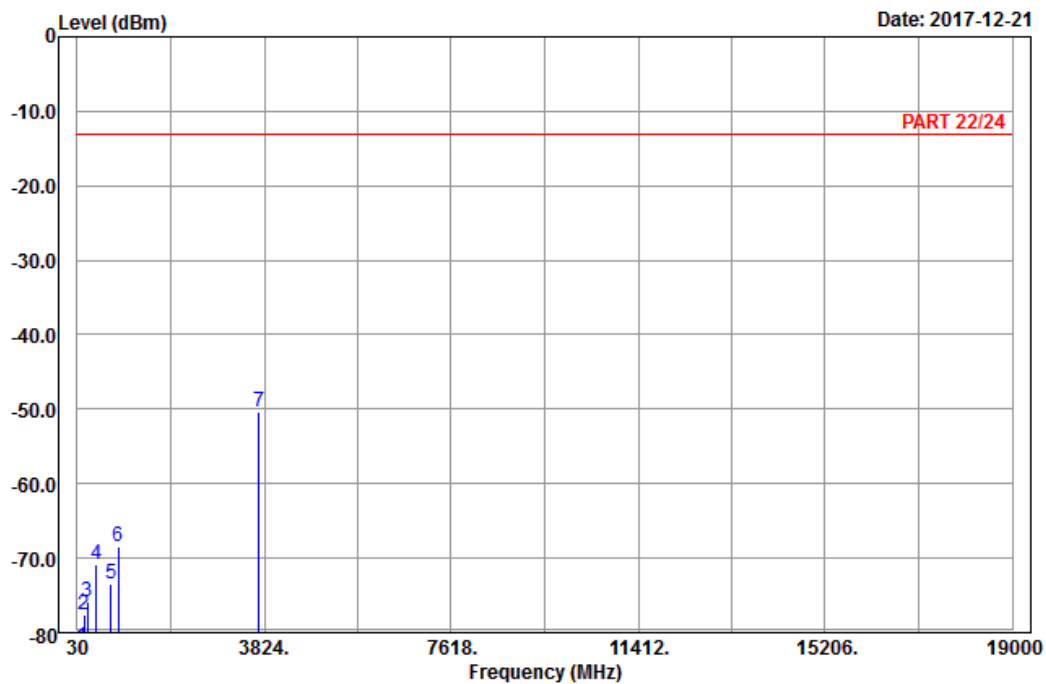

Site : 966 chamber 1
Condition: PART 22/24 Horizontal
Remark : LTE_Band 2_Link_CH18700
Tested by: Karl Lee

	Freq	Level	Read Level	Limit Line	Over Limit	Factor	Remark
	MHz	dBm	dBm	dBm	dB	dB	
1	116.40	-81.94	-73.43	-13.00	-68.94	-8.51	Peak
2	175.26	-77.49	-71.40	-13.00	-64.49	-6.09	Peak
3	237.09	-75.91	-70.22	-13.00	-62.91	-5.69	Peak
4	414.10	-70.91	-67.85	-13.00	-57.91	-3.06	Peak
5	708.10	-73.52	-73.00	-13.00	-60.52	-0.52	Peak
6	857.20	-68.41	-70.08	-13.00	-55.41	1.67	Peak
7 pp	3720.00	-50.28	-66.25	-13.00	-37.28	15.97	Peak



A D T

Data: 14

Date: 2017-12-21

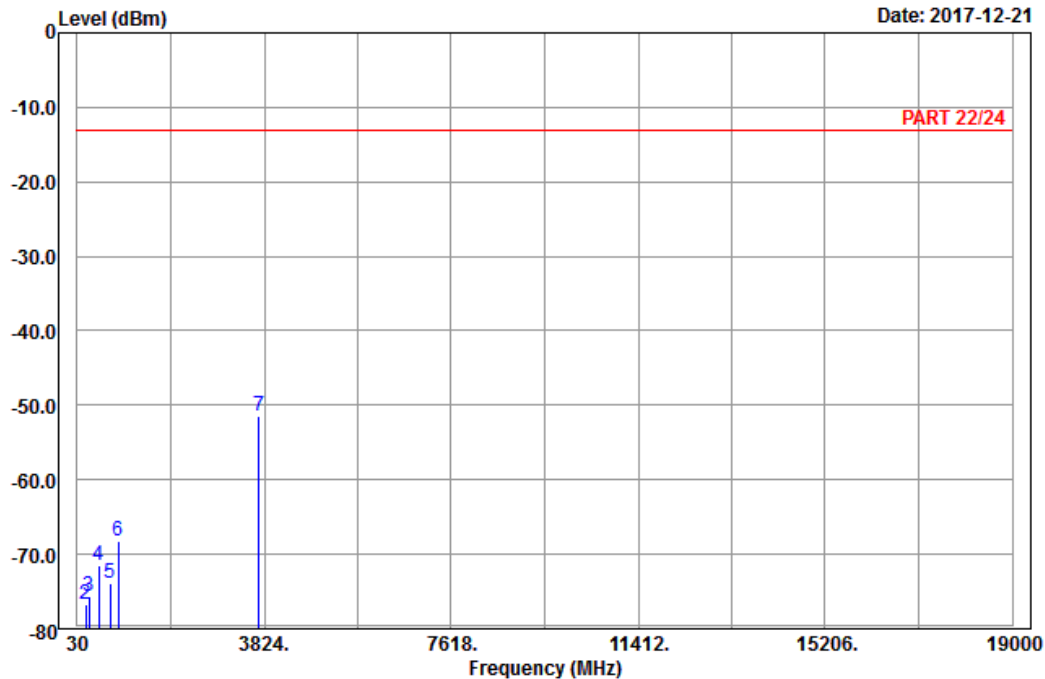

Site : 966 chamber 1
 Condition: PART 22/24 Vertical
 Remark : LTE_Band 2_Link_CH18700
 Tested by: Karl Lee

	Freq	Level	Read Level	Limit Line	Over Limit	Factor	Remark
	MHz	dBm	dBm	dBm	dB	dB	
1	97.50	-83.20	-72.97	-13.00	-70.20	-10.23	Peak
2	202.26	-76.65	-70.51	-13.00	-63.65	-6.14	Peak
3	267.60	-75.63	-69.96	-13.00	-62.63	-5.67	Peak
4	459.60	-71.51	-67.39	-13.00	-58.51	-4.12	Peak
5	702.50	-73.88	-73.47	-13.00	-60.88	-0.41	Peak
6	857.90	-68.21	-69.91	-13.00	-55.21	1.70	Peak
7 pp	3720.00	-51.36	-67.33	-13.00	-38.36	15.97	Peak

Middle Channel



Bureau Veritas Consumer Products Services Ltd., Taoyuan Branch

A D T

Data: 9

Date: 2017-12-21

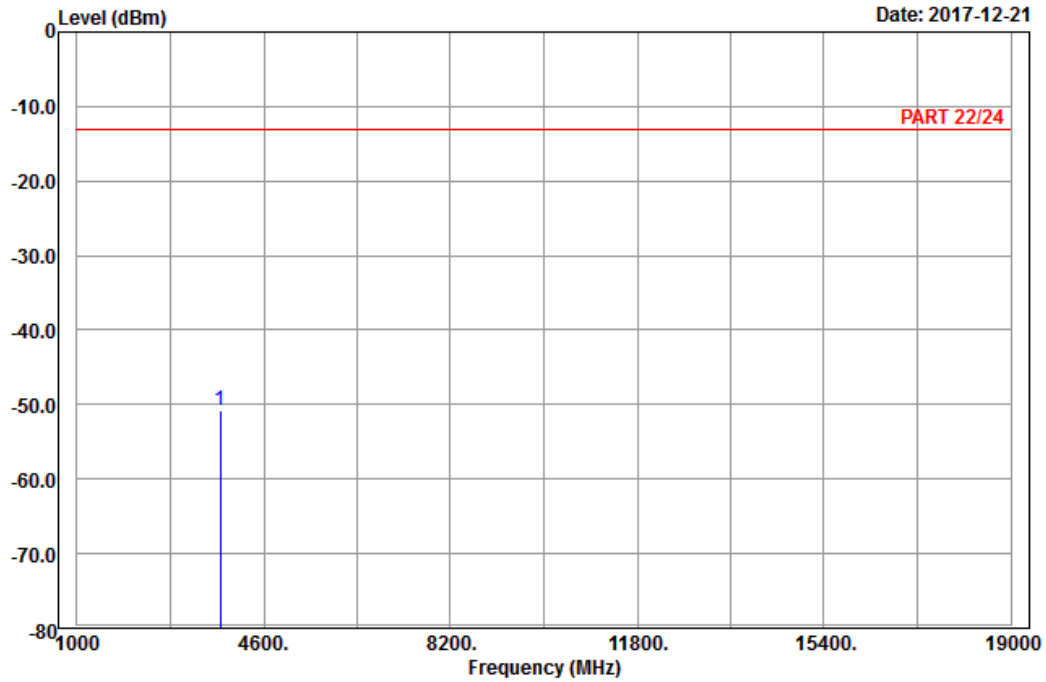

Site : 966 chamber 1
 Condition: PART 22/24 Horizontal
 Remark : LTE_Band 2_Link_CH18900
 Tested by: Karl Lee

	Read	Limit	Over			
Freq	Level	Level	Line	Limit	Factor	Remark
MHz	dBm	dBm	dBm	dB	dB	
1 pp 3760.00	-50.72	-66.86	-13.00	-37.72	16.14	Peak



Bureau Veritas Consumer Products Services Ltd., Taoyuan Branch

A D T

Data: 10

Date: 2017-12-21

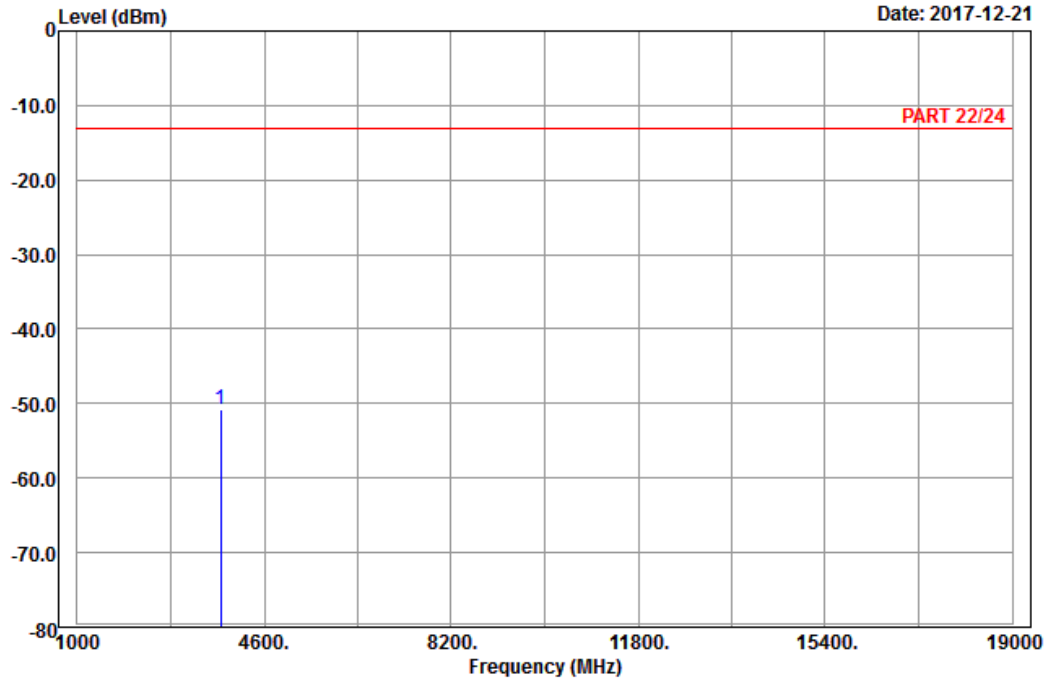

Site : 966 chamber 1
 Condition: PART 22/24 Vertical
 Remark : LTE_Band 2_Link_CH18900
 Tested by: Karl Lee

	Freq	Level	Read Level	Limit Line	Over Limit	Factor	Remark
	MHz	dBm	dBm	dBm	dB	dB	
1	pp 3760.00	-50.88	-67.02	-13.00	-37.88	16.14	Peak

High Channel



Bureau Veritas Consumer Products Services Ltd., Taoyuan Branch

A D T

Data: 9

Date: 2017-12-21

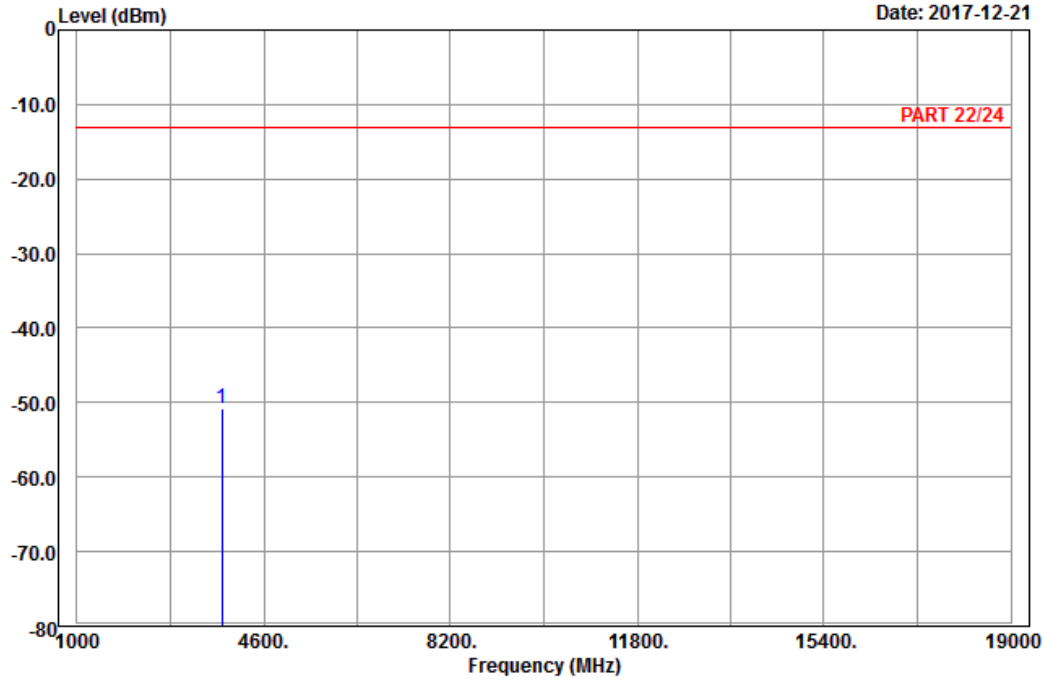

Site : 966 chamber 1
 Condition: PART 22/24 Horizontal
 Remark : LTE_Band 2_Link_CH19100
 Tested by: Karl Lee

	Read	Limit	Over			
Freq	Level	Level	Line	Limit	Factor	Remark
MHz	dBm	dBm	dBm	dB	dB	
1 pp 3800.00	-50.89	-67.30	-13.00	-37.89	16.41	Peak



Bureau Veritas Consumer Products Services Ltd., Taoyuan Branch

A D T

Data: 10

Date: 2017-12-21

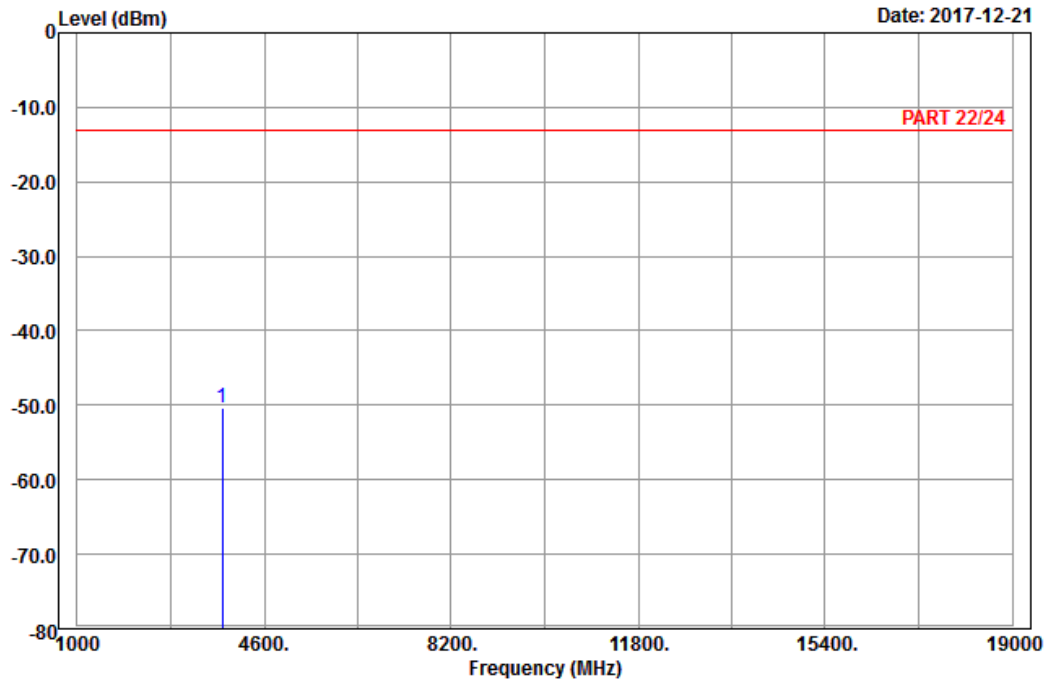

Site : 966 chamber 1
 Condition: PART 22/24 Vertical
 Remark : LTE_Band 2_Link_CH19100
 Tested by: Karl Lee

	Freq	Level	Read Level	Limit Line	Over Limit	Factor	Remark
	MHz	dBm	dBm	dBm	dB	dB	
1	pp 3800.00	-50.41	-66.82	-13.00	-37.41	16.41	Peak

5 Pictures of Test Arrangements

Please refer to the attached file (Test Setup Photo).

Appendix – Information on the Testing Laboratories

We, Bureau Veritas Consumer Products Services (H.K.) Ltd., Taoyuan Branch, were founded in 1988 to provide our best service in EMC, Radio, Telecom and Safety consultation. Our laboratories are FCC recognized accredited test firms and accredited according to ISO/IEC 17025.

If you have any comments, please feel free to contact us at the following:

Linko EMC/RF Lab

Tel: 886-2-26052180

Fax: 886-2-26051924

Hsin Chu EMC/RF/Telecom Lab

Tel: 886-3-6668565

Fax: 886-3-6668323

Hwa Ya EMC/RF/Safety

Tel: 886-3-3183232

Fax: 886-3-3270892

Email: service.adt@tw.bureauveritas.com

Web Site: www.bureauveritas-adt.com

The address and road map of all our labs can be found in our web site also.

--- END ---