



FCC RF Test Report

APPLICANT : HTC Corporation
EQUIPMENT : Smartphone
MODEL NAME : 2PWD100
FCC ID : NM82PWD100
STANDARD : FCC Part 15 Subpart C §15.247
CLASSIFICATION : (DTS) Digital Transmission System

The product was received on Jul. 25, 2016 and testing was completed on Aug. 30, 2016. We, SPORTON INTERNATIONAL INC., would like to declare that the tested sample has been evaluated in accordance with the test procedures and has been in compliance with the applicable technical standards.

The test results in this report apply exclusively to the tested model / sample. Without written approval of SPORTON INTERNATIONAL INC., the test report shall not be reproduced except in full.

Reviewed by: Joseph Lin / Supervisor

Approved by: Jones Tsai / Manager



SPORTON INTERNATIONAL INC.

No. 52, Hwa Ya 1st Rd., Hwa Ya Technology Park, Kwei-Shan District, Tao Yuan City, Taiwan, R.O.C.



TABLE OF CONTENTS

REVISION HISTORY 3

SUMMARY OF TEST RESULT 4

1 GENERAL DESCRIPTION 5

 1.1 Applicant 5

 1.2 Manufacturer 5

 1.3 Product Feature of Equipment Under Test 5

 1.4 Product Specification of Equipment Under Test 5

 1.5 Modification of EUT 5

 1.6 Testing Location 6

 1.7 Applicable Standards 6

2 TEST CONFIGURATION OF EQUIPMENT UNDER TEST 7

 2.1 Carrier Frequency and Channel 7

 2.2 Pre-Scanned RF Power 8

 2.3 Test Mode 8

 2.4 Connection Diagram of Test System 9

 2.5 Support Unit used in test configuration and system 10

 2.6 EUT Operation Test Setup 10

 2.7 Measurement Results Explanation Example 10

3 TEST RESULT 11

 3.1 6dB and 99% Bandwidth Measurement 11

 3.2 Output Power Measurement 13

 3.3 Power Spectral Density Measurement 15

 3.4 Conducted Band Edges and Spurious Emission Measurement 17

 3.5 Radiated Band Edges and Spurious Emission Measurement 30

 3.6 AC Conducted Emission Measurement 34

 3.7 Antenna Requirements 38

4 LIST OF MEASURING EQUIPMENT 39

5 UNCERTAINTY OF EVALUATION 41

APPENDIX A. CONDUCTED TEST RESULTS

APPENDIX B. RADIATED SPURIOUS EMISSION

APPENDIX C. RADIATED SPURIOUS EMISSION PLOTS

APPENDIX D. DUTY CYCLE PLOTS



SUMMARY OF TEST RESULT

Report Section	FCC Rule	Description	Limit	Result	Remark
3.1	15.247(a)(2)	6dB Bandwidth	$\geq 0.5\text{MHz}$	Pass	-
3.1	-	99% Bandwidth	-	Pass	-
3.2	15.247(b)	Power Output Measurement	$\leq 30\text{dBm}$	Pass	-
3.3	15.247(e)	Power Spectral Density	$\leq 8\text{dBm}/3\text{kHz}$	Pass	-
3.4	15.247(d)	Conducted Band Edges	$\leq 20\text{dBc}$	Pass	-
		Conducted Spurious Emission		Pass	-
3.5	15.247(d)	Radiated Band Edges and Radiated Spurious Emission	15.209(a) & 15.247(d)	Pass	Under limit 0.93 dB at 2389.94 MHz
3.6	15.207	AC Conducted Emission	15.207(a)	Pass	Under limit 16.90 dB at 0.294 MHz
3.7	15.203 & 15.247(b)	Antenna Requirement	N/A	Pass	-



1 General Description

1.1 Applicant

HTC Corporation

No.23, Xinghua Rd., Taoyuan District, Taoyuan City, Taiwan 330

1.2 Manufacturer

HTC Corporation

No.23, Xinghua Rd., Taoyuan District, Taoyuan City, Taiwan 330

1.3 Product Feature of Equipment Under Test

Product Feature	
Equipment	Smartphone
Model Name	2PWD100
FCC ID	NM82PWD100
Sample 1	EUT with battery 1 and LCD panel 1_black
Sample 2	EUT with battery 2 and LCD panel 2_white
EUT supports Radios application	GSM/EGPRS/WCDMA/HSPA/LTE/NFC WLAN 11a/b/g/n HT20/HT40 Bluetooth EDR/LE
EUT Stage	Production Unit

Remark: The above EUT's information was declared by manufacturer. Please refer to the specifications or user's manual for more detailed description.

1.4 Product Specification of Equipment Under Test

Standards-related Product Specification	
Tx/Rx Channel Frequency Range	2412 MHz ~ 2462 MHz
Maximum (Peak) Output Power to antenna	802.11b : 20.90 dBm (0.1230 W) 802.11g : 24.30 dBm (0.2692 W) 802.11n HT20 : 24.53 dBm (0.2838 W) 802.11n HT40 : 24.92 dBm (0.3105 W)
99% Occupied Bandwidth	802.11b : 12.80MHz 802.11g : 17.75MHz 802.11n HT20 : 18.50MHz 802.11n HT40 : 36.60MHz
Antenna Type / Gain	PIFA Antenna type with gain -2.00 dBi
Type of Modulation	802.11b : DSSS (DBPSK / DQPSK / CCK) 802.11g/n : OFDM (BPSK / QPSK / 16QAM / 64QAM)

1.5 Modification of EUT

No modifications are made to the EUT during all test items.



1.6 Testing Location

Sporton Lab is accredited to ISO 17025 by Taiwan Accreditation Foundation (TAF code : 1190) and the FCC designation No. TW1022 under the FCC 2.948(e) by Mutual Recognition Agreement (MRA) in FCC Test.

Test Site	SPORTON INTERNATIONAL INC.	
Test Site Location	No. 52, Hwa Ya 1 st Rd., Hwa Ya Technology Park, Kwei-Shan District, Tao Yuan City, Taiwan, R.O.C. TEL: +886-3-327-3456 FAX: +886-3-328-4978	
Test Site No.	Sporton Site No.	
	TH02-HY	CO05-HY

Note: The test site complies with ANSI C63.4 2014 requirement.

Test Site	SPORTON INTERNATIONAL INC.	
Test Site Location	No.58, Aly. 75, Ln. 564, Wenhua 3rd Rd. Guishan Dist, Taoyuan City, Taiwan (R.O.C.) TEL: +886-3-327-0868 FAX: +886-3-327-0855	
Test Site No.	Sporton Site No.	
	03CH12-HY	

1.7 Applicable Standards

According to the specifications of the manufacturer, the EUT must comply with the requirements of the following standards:

- ♦ FCC Part 15 Subpart C §15.247
- ♦ FCC KDB Publication No. 558074 D01 DTS Meas. Guidance v03r05
- ♦ ANSI C63.10-2013

Remark:

1. All test items were verified and recorded according to the standards and without any deviation during the test.
2. This EUT has also been tested and complied with the requirements of FCC Part 15, Subpart B, recorded in a separate test report.



2 Test Configuration of Equipment Under Test

The EUT has been associated with peripherals and configuration operated in a manner tended to maximize its emission characteristics in a typical application. Frequency range investigated: conducted emission (150 kHz to 30 MHz) and radiated emission (9 kHz to the 10th harmonic of the highest fundamental frequency or to 40 GHz, whichever is lower). For radiated measurement, pre-scanned in three orthogonal panels, X, Y, Z. The worst cases (X plane) were recorded in this report.

2.1 Carrier Frequency and Channel

Frequency Band	Channel	Freq. (MHz)	Channel	Freq. (MHz)
2400-2483.5 MHz	1	2412	7	2442
	2	2417	8	2447
	3	2422	9	2452
	4	2427	10	2457
	5	2432	11	2462
	6	2437	-	-



2.2 Pre-Scanned RF Power

Preliminary tests were performed in different data rate and data rate associated with the highest power were chosen for full test shown in the following tables.

802.11b mode				
Data Rate (MHz)	1M bps	2M bps	5.5M bps	11M bps
Peak Power (dBm)	20.90	20.79	20.89	20.85

802.11g mode								
Data Rate (MHz)	6M bps	9M bps	12M bps	18M bps	24M bps	36M bps	48M bps	54M bps
Peak Power (dBm)	24.30	23.89	24.00	24.22	23.69	22.93	24.22	24.11

802.11n HT20 mode								
Data Rate (MHz)	MCS0	MCS1	MCS2	MCS3	MCS4	MCS5	MCS6	MCS7
Peak Power (dBm)	24.29	24.14	24.07	23.96	24.25	24.24	24.26	24.04

802.11n HT40 mode								
Data Rate (MHz)	MCS0	MCS1	MCS2	MCS3	MCS4	MCS5	MCS6	MCS7
Peak Power (dBm)	24.92	24.77	24.45	24.11	23.71	24.21	24.23	23.96

2.3 Test Mode

Final test mode of conducted test items and radiated spurious emissions are considering the modulation and worse data rates from the power table described in section 2.2.

Modulation	Data Rate
802.11b	1 Mbps
802.11g	6 Mbps
802.11n HT20	MCS0
802.11n HT40	MCS0

Test Cases	
AC Conducted Emission	Mode 1 : GSM850 Idle + Bluetooth Link + WLAN (5GHz) Link + USB Cable 2 (Charging from Adapter 2) + Earphone 2 + MP3 for Sample 1
Remark: For Radiated Test Cases, the tests were performed with adapter 1, earphone 1, USB cable 2 and sample 1.	

2.4 Connection Diagram of Test System

<WLAN Tx Mode>

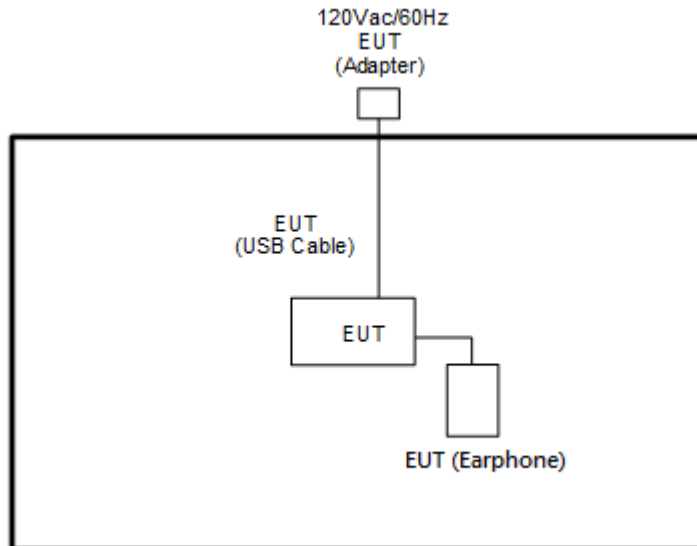

<AC Conducted Emission Mode>

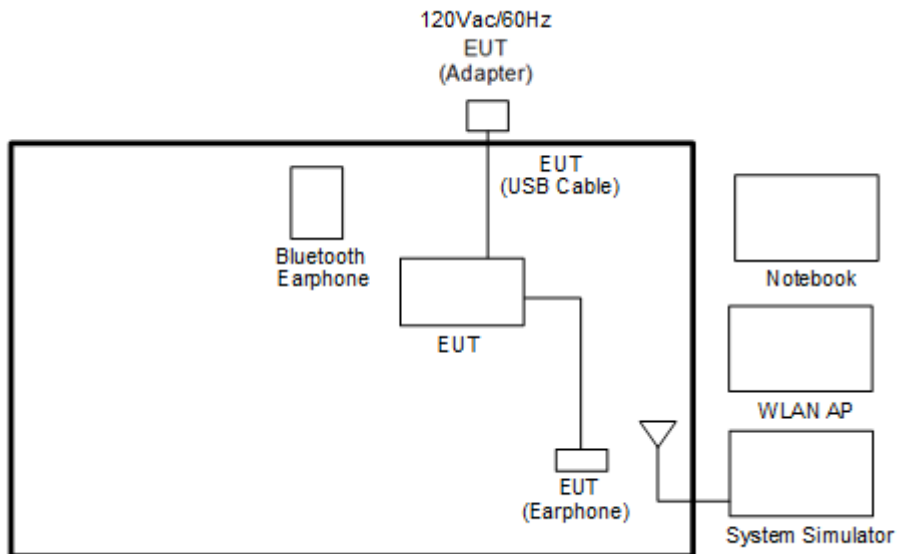



2.5 Support Unit used in test configuration and system

Item	Equipment	Trade Name	Model Name	FCC ID	Data Cable	Power Cord
1.	System Simulator	Anritsu	MT8820C	N/A	N/A	Unshielded, 1.8 m
2.	System Simulator	R&S	CMU 200	N/A	N/A	Unshielded, 1.8 m
3.	Bluetooth Earphone	Sony Ericsson	MW600	PY7DDA-2029	N/A	N/A
4.	WLAN AP	D-Link	DIR-628	KA2DIR628A2	N/A	Unshielded, 1.8 m
5.	Notebook	DELL	Latitude E6320	FCC DoC/ Contains FCC ID: QDS-BRCM1054	N/A	AC I/P: Unshielded, 1.2 m DC O/P: Shielded, 1.8 m
6.	SD Card	SanDisk	MicroSD HC	FCC DoC	N/A	N/A

2.6 EUT Operation Test Setup

For WLAN RF test items, an engineering test program was provided and enabled to make EUT continuous transmit/receive.

2.7 Measurement Results Explanation Example

For all conducted test items:

The offset level is set in the spectrum analyzer to compensate the RF cable loss and attenuator factor between EUT conducted output port and spectrum analyzer. With the offset compensation, the spectrum analyzer reading level is exactly the EUT RF output level.

Example :

The spectrum analyzer offset is derived from RF cable loss and attenuator factor.

Offset = RF cable loss + attenuator factor.

Following shows an offset computation example with cable loss 4.2 dB and 10dB attenuator.

$$\begin{aligned} \text{Offset(dB)} &= \text{RF cable loss(dB)} + \text{attenuator factor(dB)}. \\ &= 4.2 + 10 = 14.2 \text{ (dB)} \end{aligned}$$

3 Test Result

3.1 6dB and 99% Bandwidth Measurement

3.1.1 Limit of 6dB and 99% Bandwidth

The minimum 6 dB bandwidth shall be at least 500 kHz.

3.1.2 Measuring Instruments

The measuring equipment is listed in the section 4 of this test report.

3.1.3 Test Procedures

1. The testing follows FCC KDB Publication No. 558074 DTS D01 Meas. Guidance v03r05.
2. The RF output of EUT was connected to the spectrum analyzer by RF cable and attenuator. The path loss was compensated to the results for each measurement.
3. Set to the maximum power setting and enable the EUT transmit continuously.
4. Make the measurement with the spectrum analyzer's resolution bandwidth (RBW) = 100 kHz. Set the Video bandwidth (VBW) = 300 kHz. In order to make an accurate measurement. The 6 dB bandwidth must be greater than 500 kHz.
5. For 99% Bandwidth Measurement, the spectrum analyzer's resolution bandwidth (RBW) = 1MHz and set the Video bandwidth (VBW) = 3MHz.
6. Measure and record the results in the test report.

3.1.4 Test Setup

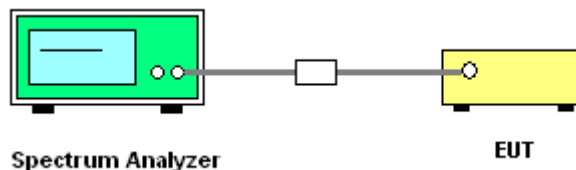



3.1.5 Test Result of 6dB and 99% Occupied Bandwidth

Please refer to Appendix A.

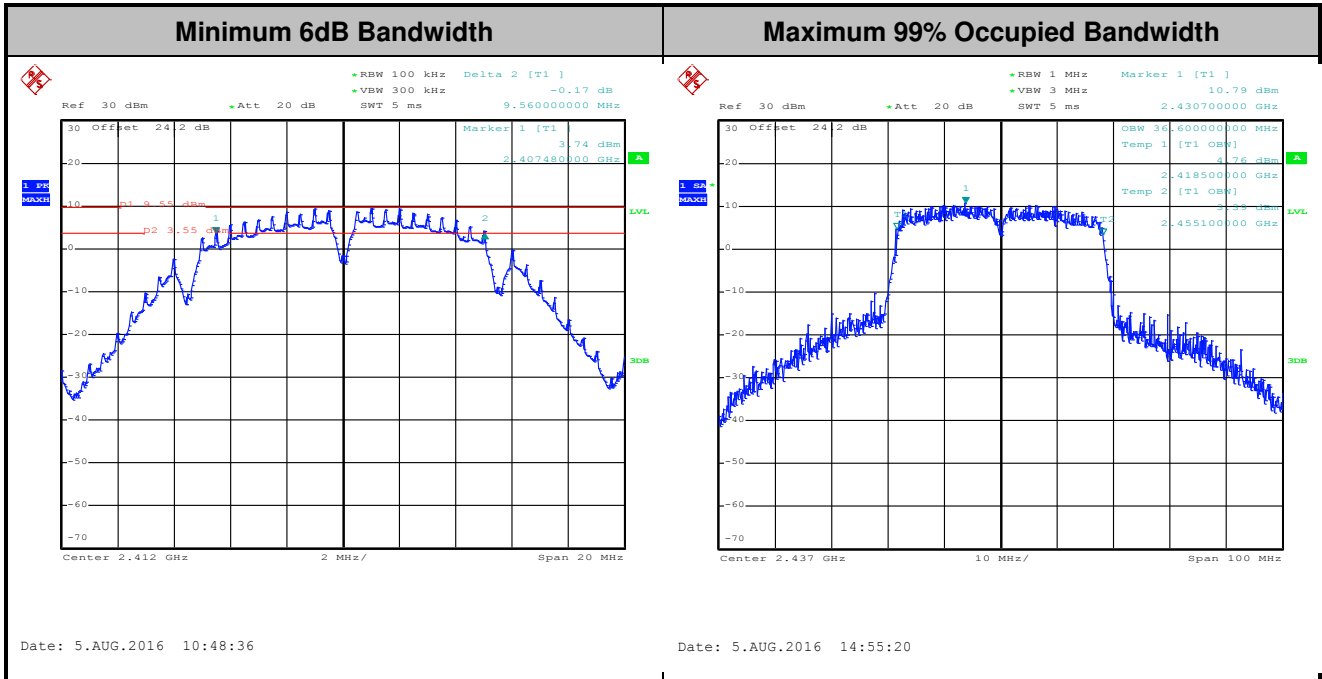

Note : The occupied channel bandwidth is maintained within the band of operation for all of the modulations.

3.2 Output Power Measurement

3.2.1 Limit of Output Power

For systems using digital modulation in the 2400-2483.5MHz, the limit for peak output power is 30dBm. If transmitting antenna of directional gain greater than 6dBi are used the peak output power from the intentional radiator shall be reduced below the above stated value by the amount in dB that the directional gain of the antenna exceeds 6 dBi. In case of point-to-point operation, the limit has to be reduced by 1dB for every 3dB that the directional gain of the antenna exceeds 6dBi.

3.2.2 Measuring Instruments

The measuring equipment is listed in the section 4 of this test report.

3.2.3 Test Procedures

1. The testing follows the Measurement Procedure of FCC KDB No. 558074 DTS D01 Meas. Guidance v03r05 section 9.1.2 PKPM1 Peak power meter method.
2. The RF output of EUT was connected to the power meter by RF cable and attenuator. The path loss was compensated to the results for each measurement.
3. Set to the maximum power setting and enable the EUT transmit continuously.
4. Measure the conducted output power and record the results in the test report.

3.2.4 Test Setup

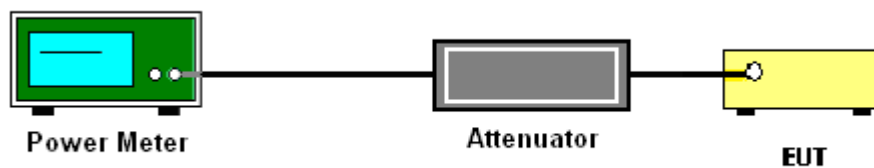



3.2.5 Test Result of Peak Output Power

Please refer to Appendix A.

3.2.6 Test Result of Average output Power (Reporting Only)

Please refer to Appendix A.

3.3 Power Spectral Density Measurement

3.3.1 Limit of Power Spectral Density

The peak power spectral density shall not be greater than 8dBm in any 3kHz band at any time interval of continuous transmission.

3.3.2 Measuring Instruments

The measuring equipment is listed in the section 4 of this test report.

3.3.3 Test Procedures

1. The testing follows Measurement Procedure 10.2 Method PKPSD of FCC KDB Publication No. 558074 D01 DTS Meas. Guidance v03r05
2. The RF output of EUT was connected to the spectrum analyzer by RF cable and attenuator. The path loss was compensated to the results for each measurement.
3. Set to the maximum power setting and enable the EUT transmit continuously.
4. Make the measurement with the spectrum analyzer's resolution bandwidth (RBW) = 3 kHz. Video bandwidth VBW = 10 kHz In order to make an accurate measurement, set the span to 1.5 times DTS Channel Bandwidth. (6dB BW)
5. Detector = peak, Sweep time = auto couple, Trace mode = max hold, Allow trace to fully stabilize. Use the peak marker function to determine the maximum power level.
6. Measure and record the results in the test report.

3.3.4 Test Setup

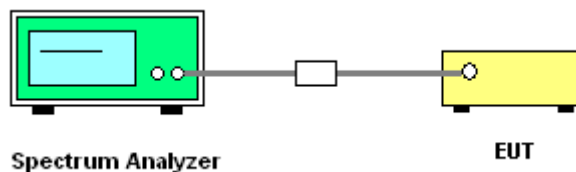



3.3.5 Test Result of Power Spectral Density

Please refer to Appendix A.

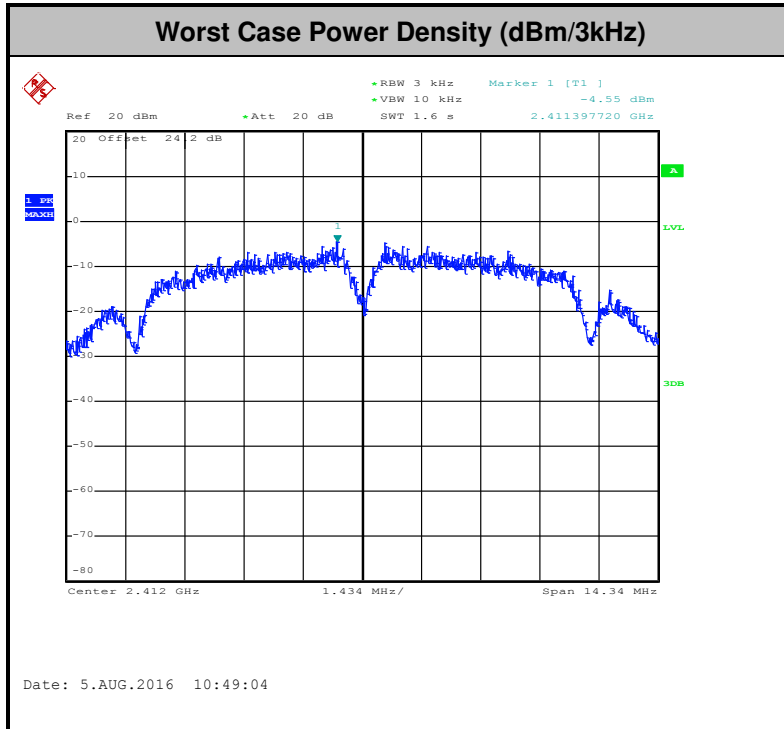

3.4 Conducted Band Edges and Spurious Emission Measurement

3.4.1 Limit of Conducted Band Edges and Spurious Emission Measurement

In any 100 kHz bandwidth outside of the authorized frequency band, the emissions which fall in the non-restricted bands shall be attenuated at least 20 dB / 30dB relative to the maximum PSD level in 100 kHz by RF conducted measurement and radiated emissions which fall in the restricted bands, as defined in Section 15.205(a), must also comply with the radiated emission limits specified in Section 15.209(a).

3.4.2 Measuring Instruments

The measuring equipment is listed in the section 4 of this test report.

3.4.3 Test Procedures

1. The testing follows FCC KDB Publication No. 558074 D01 DTS Meas. Guidance v03r05.
2. The RF output of EUT was connected to the spectrum analyzer by RF cable and attenuator. The path loss was compensated to the results for each measurement.
3. Set to the maximum power setting and enable the EUT transmit continuously.
4. Set RBW = 100 kHz, VBW=300 kHz, Peak Detector. Unwanted Emissions measured in any 100 kHz bandwidth outside of the authorized frequency band shall be attenuated by at least 20 dB relative to the maximum in-band peak PSD level in 100 kHz when maximum peak conducted output power procedure is used. If the transmitter complies with the conducted power limits based on the use of RMS averaging over a time interval, the attenuation required under this paragraph shall be 30 dB instead of 20 dB per 15.247(d).
5. Measure and record the results in the test report.
6. The RF fundamental frequency should be excluded against the limit line in the operating frequency band.

3.4.4 Test Setup

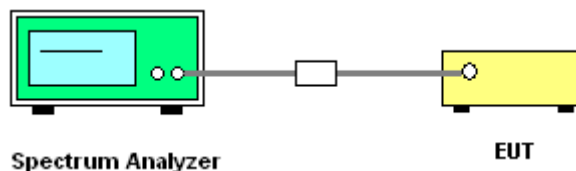



3.4.5 Test Result of Conducted Band Edges and Spurious Emission

Test Mode :	802.11b	Temperature :	21~25°C
Test Band :	2.4GHz Low	Relative Humidity :	51~54%
Test Channel :	01	Test Engineer :	Aking Chang and AC Chang

WLAN 802.11b Channel 01

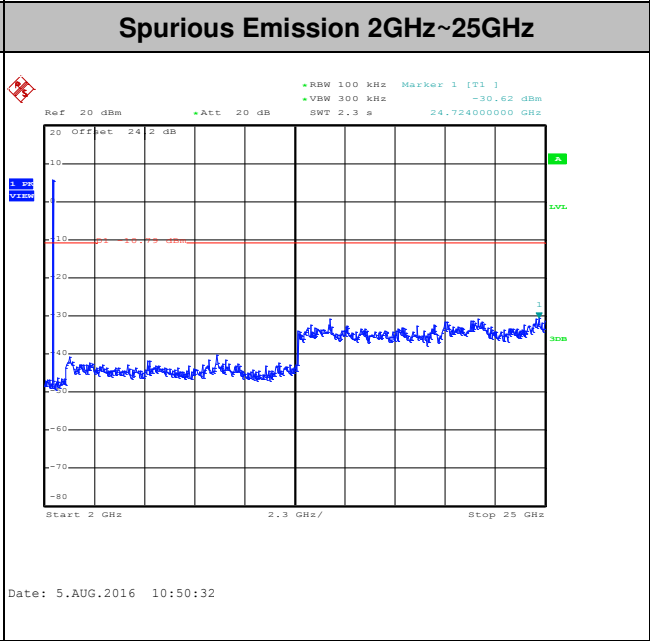
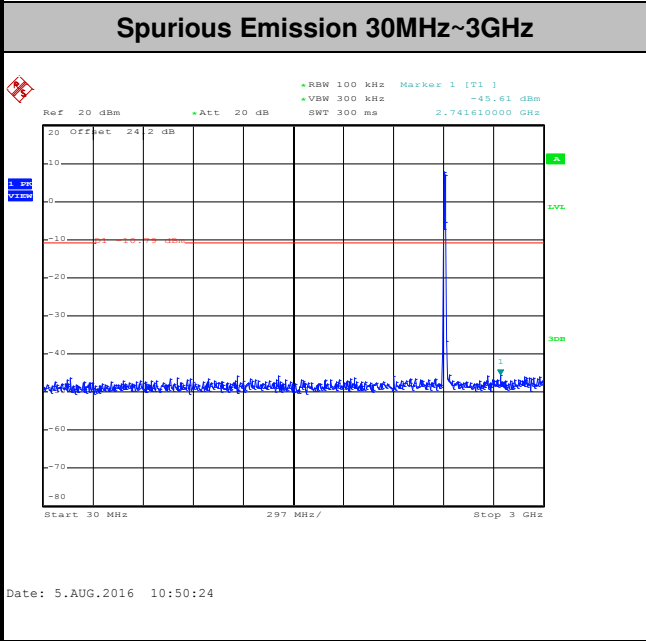
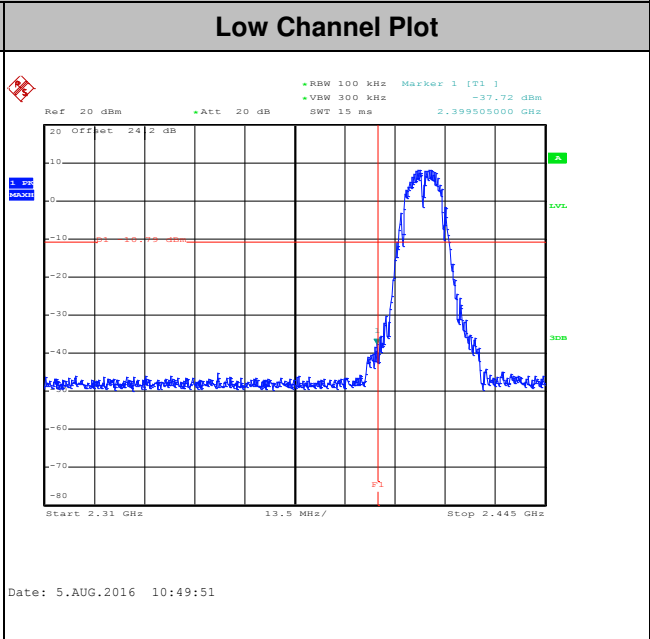
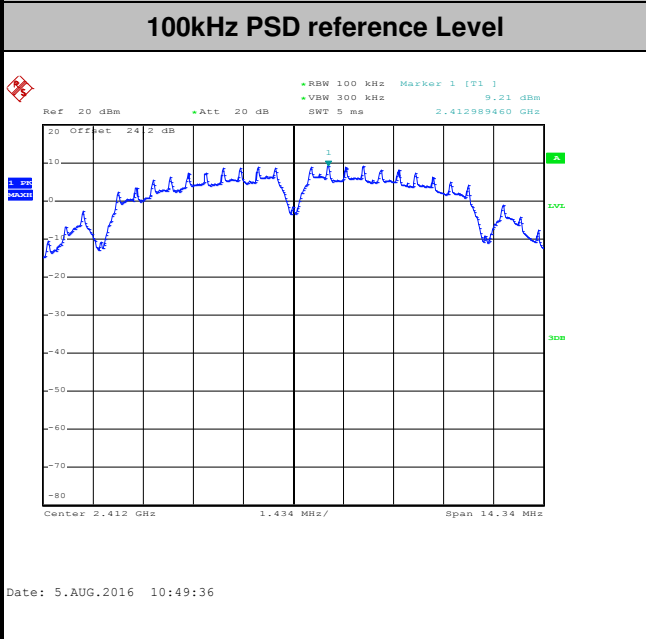



Test Mode :	802.11b	Temperature :	21~25°C
Test Band :	2.4GHz Mid	Relative Humidity :	51~54%
Test Channel :	06	Test Engineer :	Aking Chang and AC Chang

WLAN 802.11b Channel 06

100kHz PSD reference Level

Mid Channel Plot

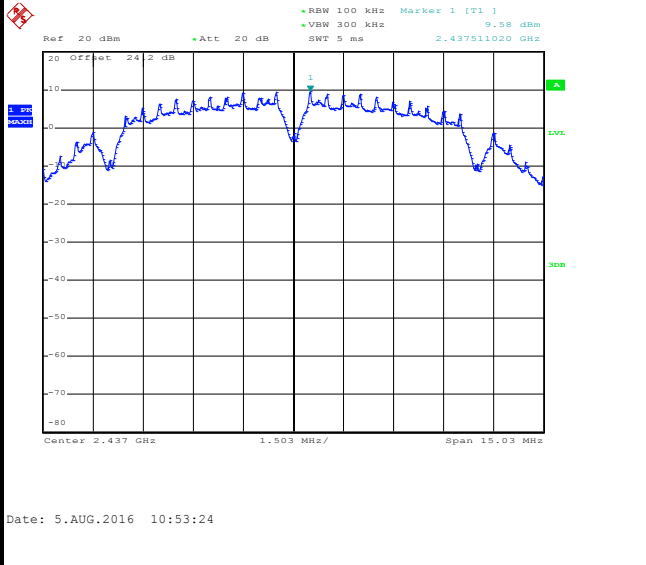

Spurious Emission 30MHz~3GHz

Spurious Emission 2GHz~25GHz

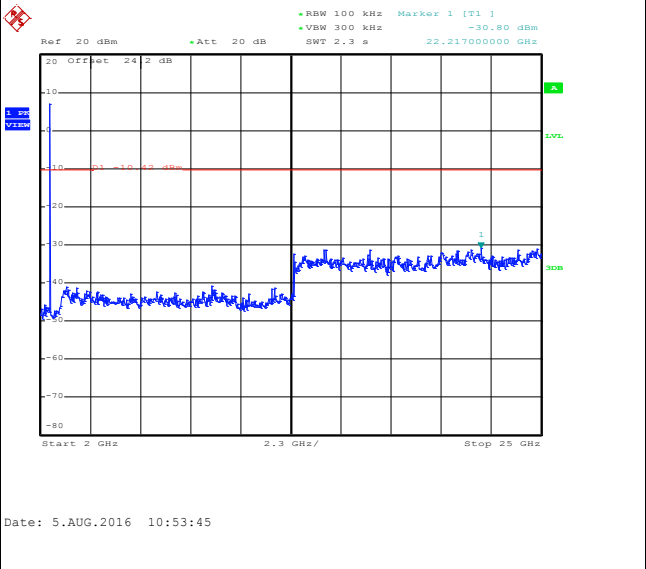
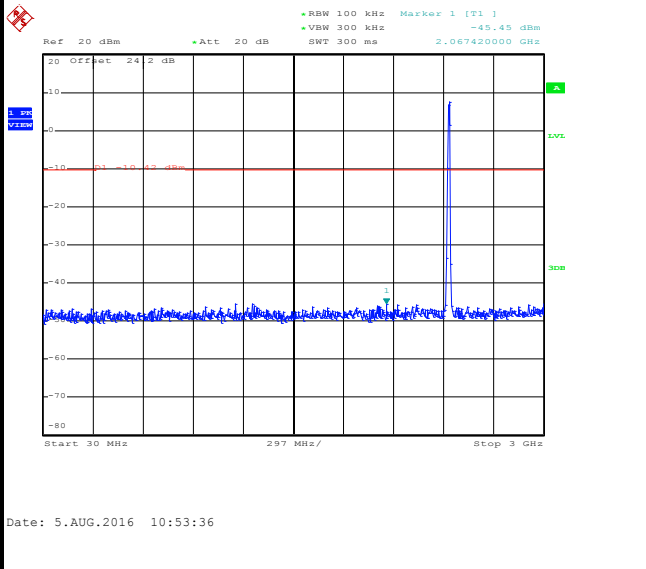



Test Mode :	802.11b	Temperature :	21~25°C
Test Band :	2.4GHz High	Relative Humidity :	51~54%
Test Channel :	11	Test Engineer :	Aking Chang and AC Chang

WLAN 802.11b Channel 11

100kHz PSD reference Level

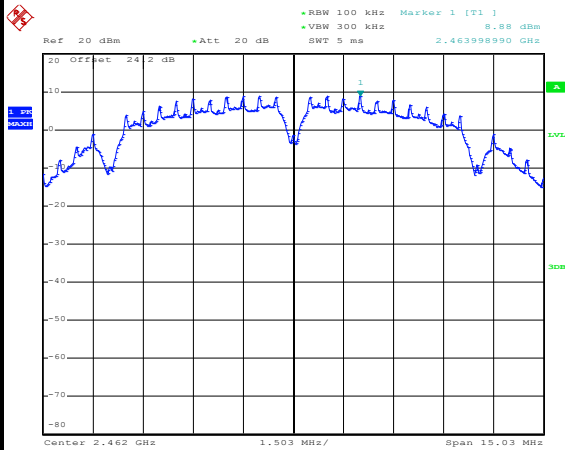

Date: 5.AUG.2016 10:57:11

High Channel Plot

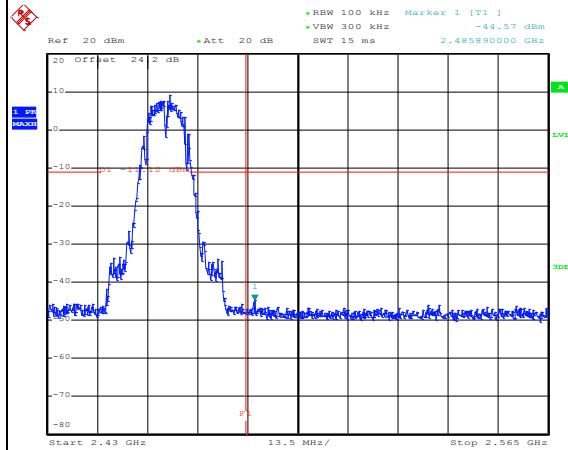

Date: 5.AUG.2016 10:57:29

Spurious Emission 30MHz~3GHz

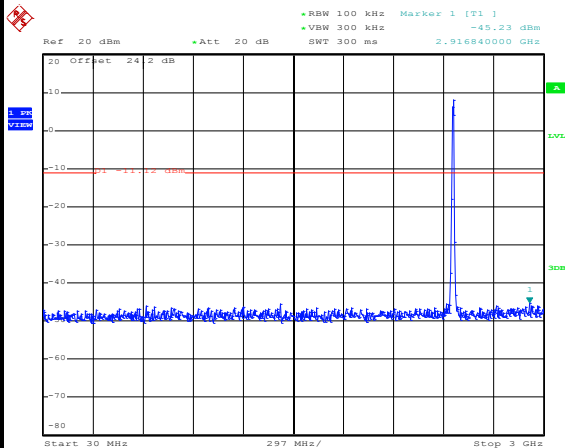

Date: 5.AUG.2016 10:57:41

Spurious Emission 2GHz~25GHz

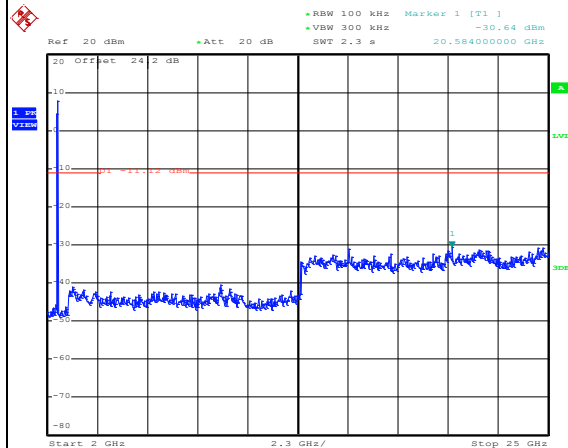

Date: 5.AUG.2016 10:57:50



Test Mode :	802.11g	Temperature :	21~25°C
Test Band :	2.4GHz Low	Relative Humidity :	51~54%
Test Channel :	01	Test Engineer :	Aking Chang and AC Chang

WLAN 802.11g Channel 01

100kHz PSD reference Level

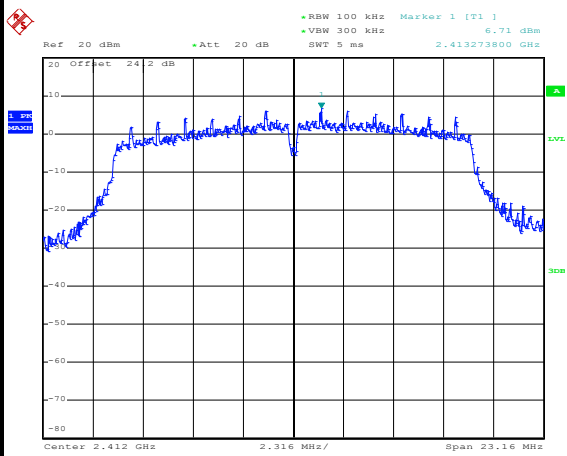

Date: 5.AUG.2016 11:41:21

Low Channel Plot

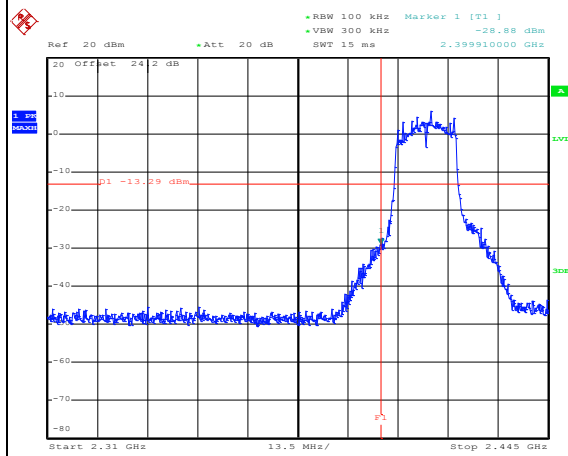

Date: 5.AUG.2016 11:41:39

Spurious Emission 30MHz~3GHz

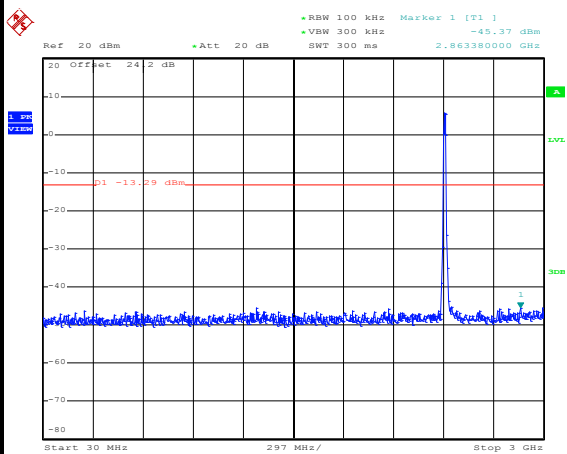

Date: 5.AUG.2016 11:41:51

Spurious Emission 2GHz~25GHz

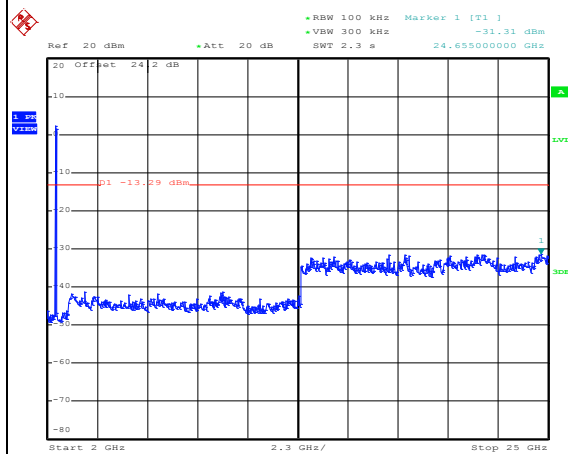

Date: 5.AUG.2016 11:41:59



Test Mode :	802.11g	Temperature :	21~25°C
Test Band :	2.4GHz Mid	Relative Humidity :	51~54%
Test Channel :	06	Test Engineer :	Aking Chang and AC Chang

WLAN 802.11g Channel 06

100kHz PSD reference Level

Mid Channel Plot

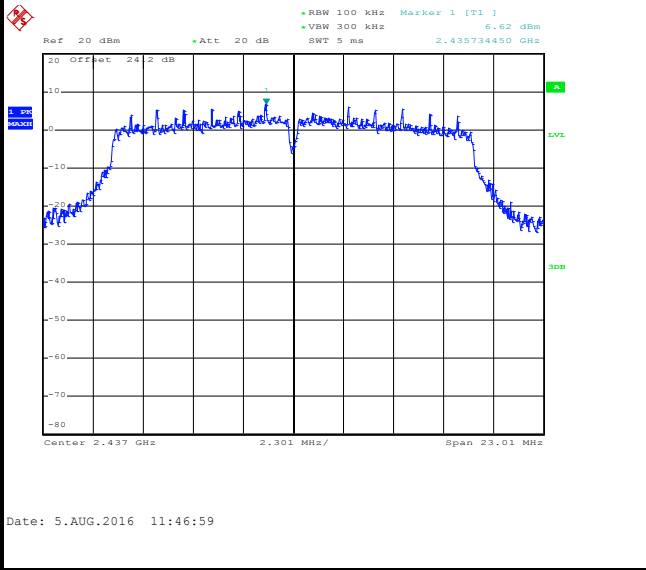

Spurious Emission 30MHz~3GHz

Spurious Emission 2GHz~25GHz

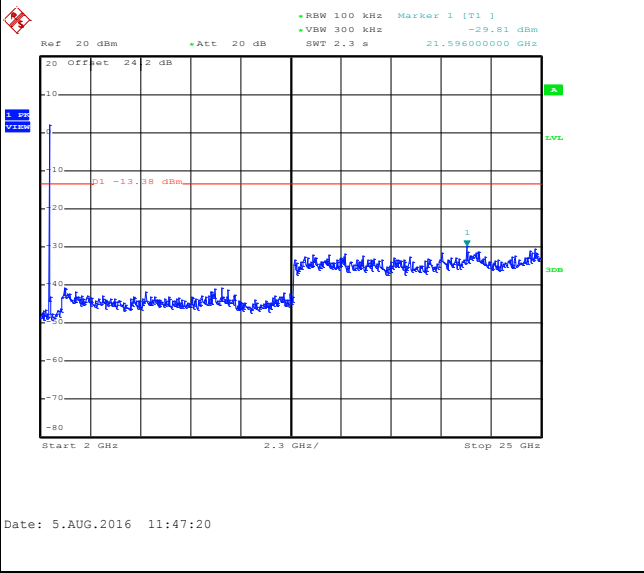
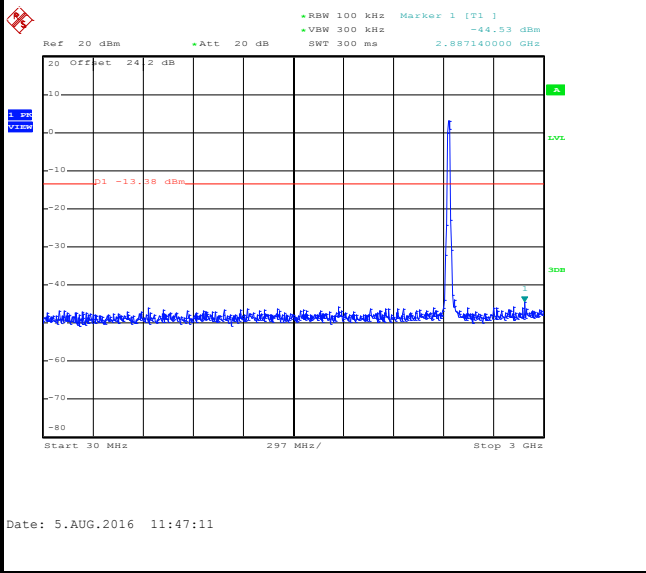



Test Mode :	802.11g	Temperature :	21~25°C
Test Band :	2.4GHz High	Relative Humidity :	51~54%
Test Channel :	11	Test Engineer :	Aking Chang and AC Chang

WLAN 802.11g Channel 11

100kHz PSD reference Level

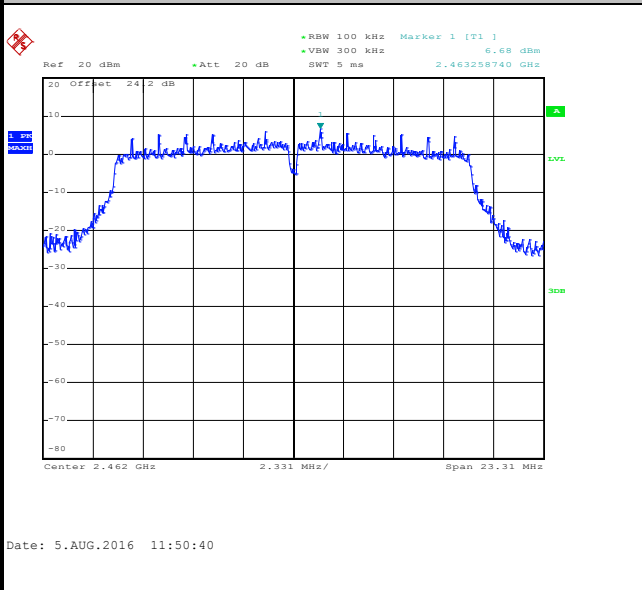

High Channel Plot

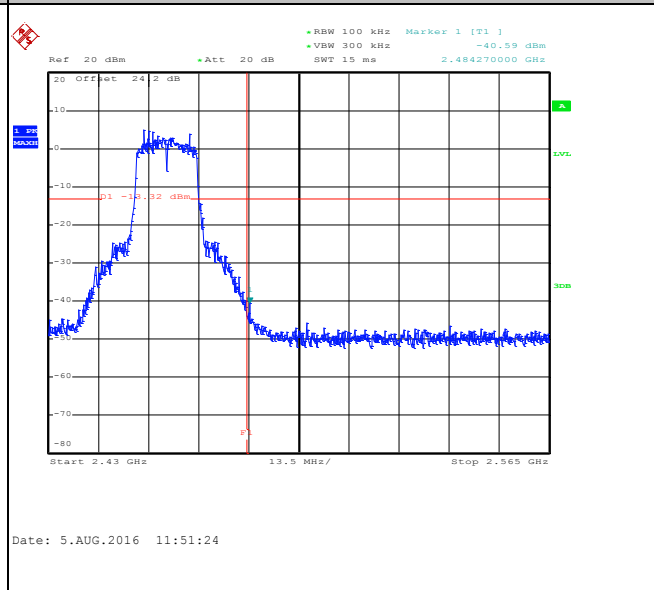

Spurious Emission 30MHz~3GHz

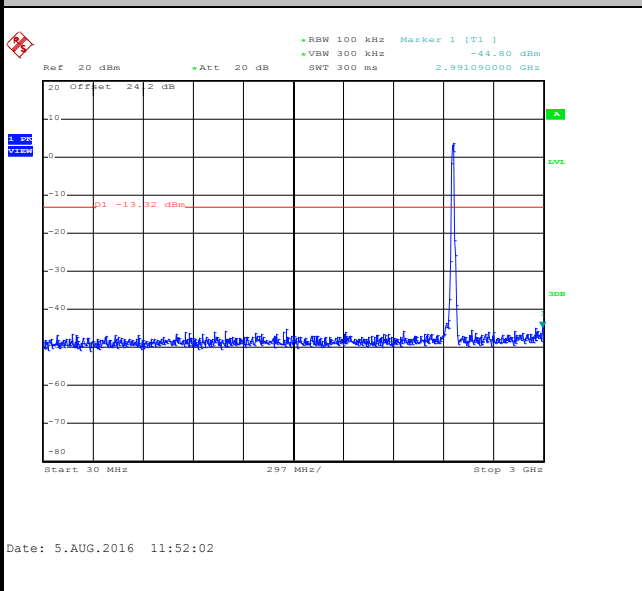

Spurious Emission 2GHz~25GHz

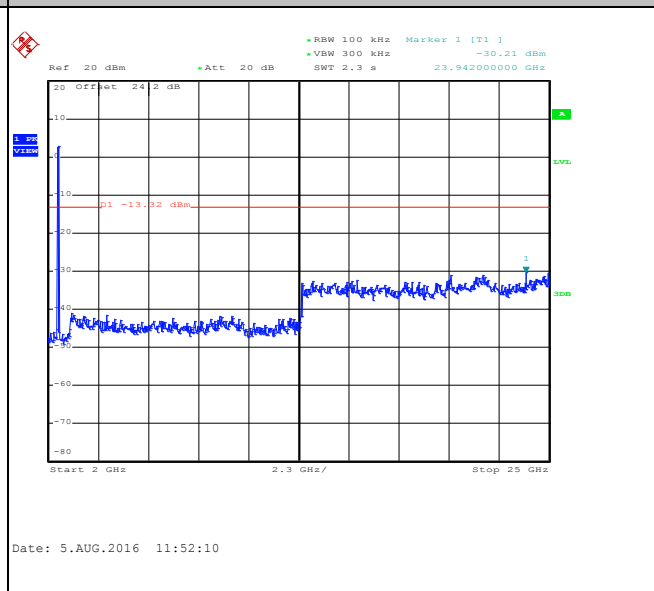



Test Mode :	802.11n HT20	Temperature :	21~25°C
Test Band :	2.4GHz Low	Relative Humidity :	51~54%
Test Channel :	01	Test Engineer :	Aking Chang and AC Chang

WLAN 802.11n HT20 Channel 01

100kHz PSD reference Level

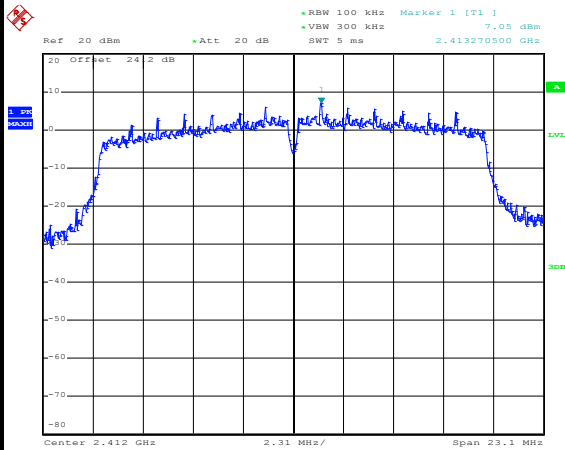

Date: 5.AUG.2016 13:34:18

Low Channel Plot

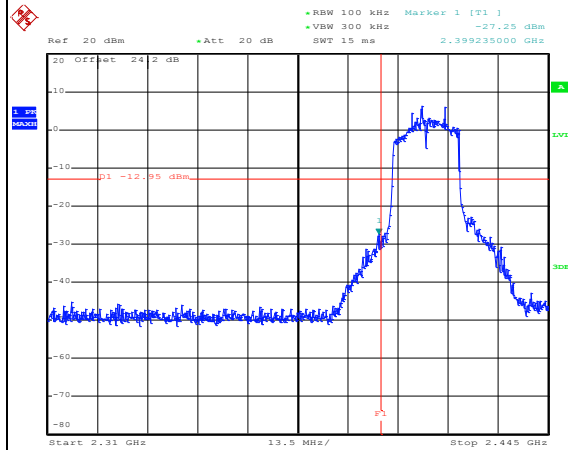

Date: 5.AUG.2016 13:34:39

Spurious Emission 30MHz~3GHz

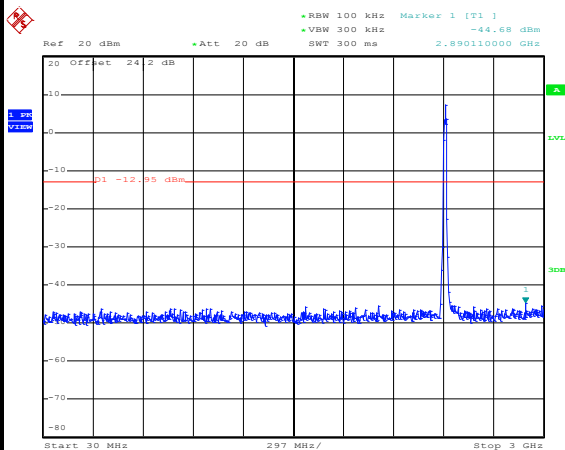

Date: 5.AUG.2016 13:34:51

Spurious Emission 2GHz~25GHz

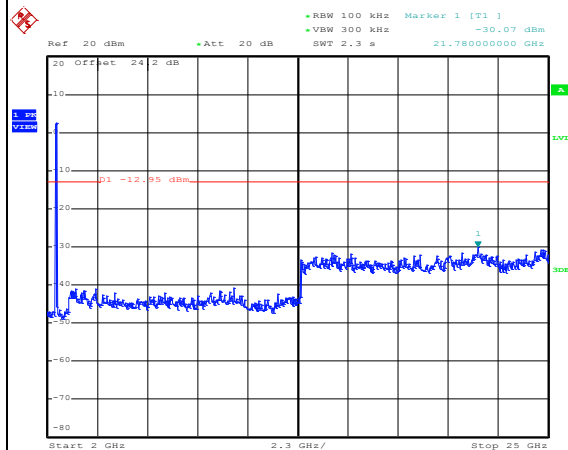

Date: 5.AUG.2016 13:35:00



Test Mode :	802.11n HT20	Temperature :	21~25°C
Test Band :	2.4GHz Mid	Relative Humidity :	51~54%
Test Channel :	06	Test Engineer :	Aking Chang and AC Chang

WLAN 802.11n HT20 Channel 06

100kHz PSD reference Level

Mid Channel Plot

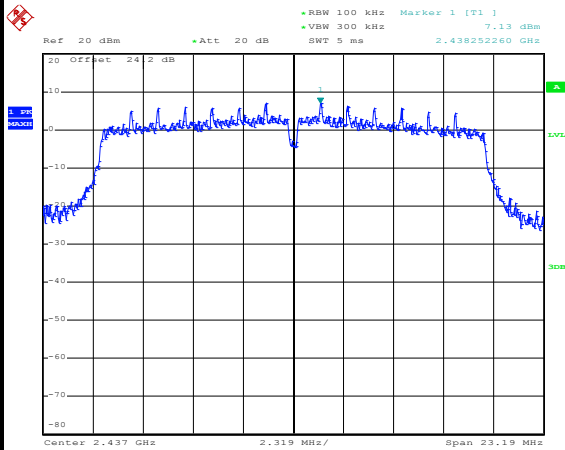

Date: 5.AUG.2016 13:39:09

Spurious Emission 30MHz~3GHz

Spurious Emission 2GHz~25GHz

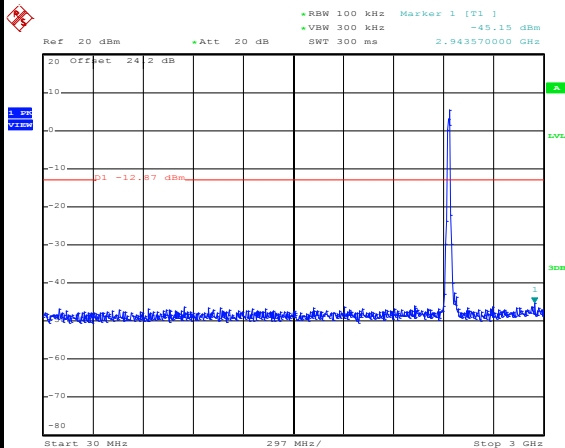

Date: 5.AUG.2016 13:39:21

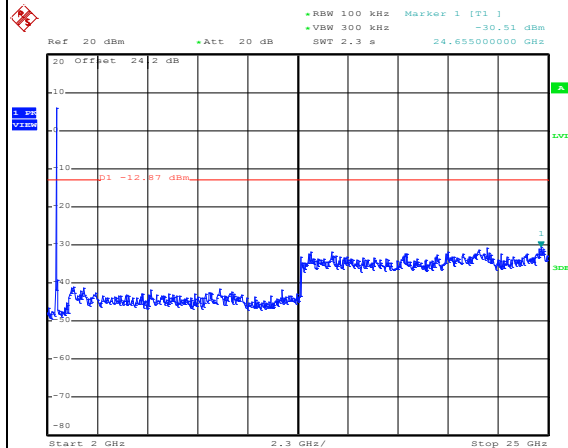

Date: 5.AUG.2016 13:39:29



Test Mode :	802.11n HT20	Temperature :	21~25°C
Test Band :	2.4GHz High	Relative Humidity :	51~54%
Test Channel :	11	Test Engineer :	Aking Chang and AC Chang

WLAN 802.11n HT20 Channel 11

100kHz PSD reference Level

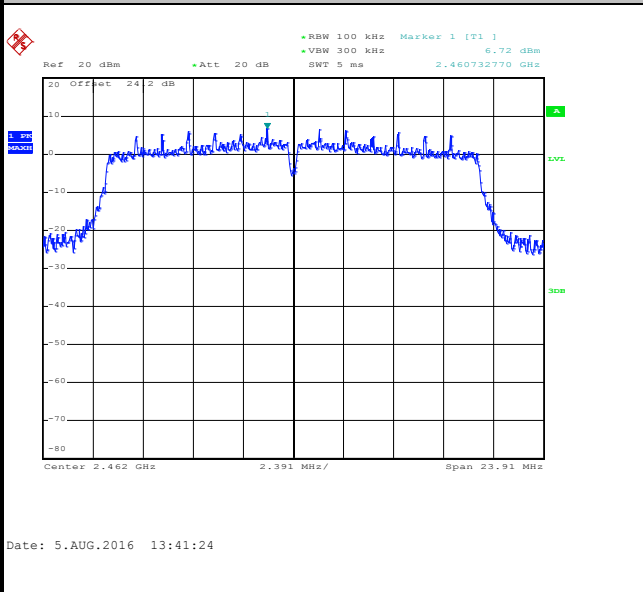

High Channel Plot

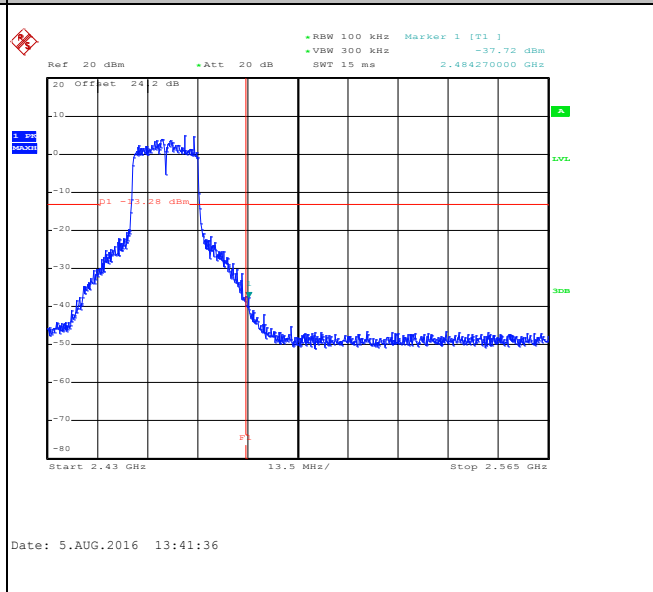

Spurious Emission 30MHz~3GHz

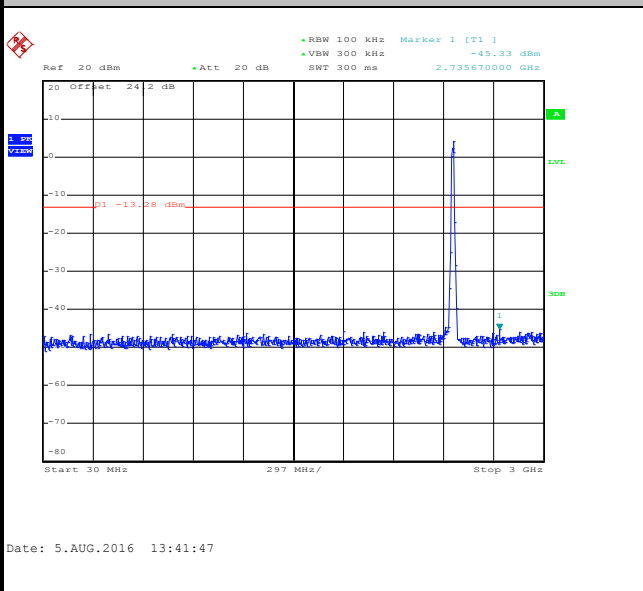

Spurious Emission 2GHz~25GHz

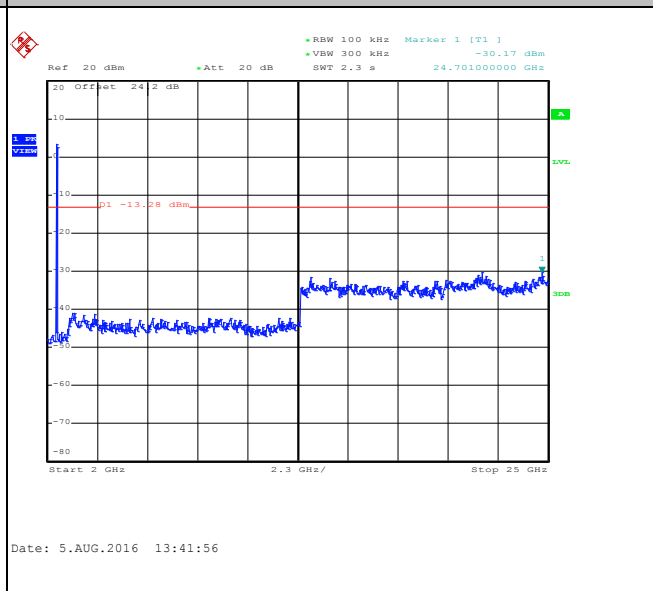



Test Mode :	802.11n HT40	Temperature :	21~25°C
Test Band :	2.4GHz Low	Relative Humidity :	51~54%
Test Channel :	03	Test Engineer :	Aking Chang and AC Chang

WLAN 802.11n HT40 Channel 03

100kHz PSD reference Level

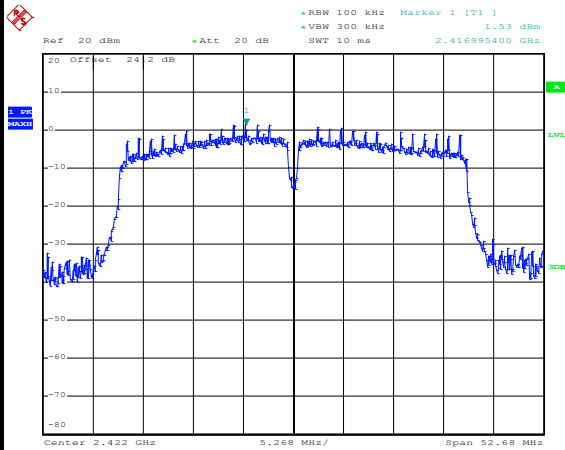

Date: 30.AUG.2016 19:31:28

Low Channel Plot

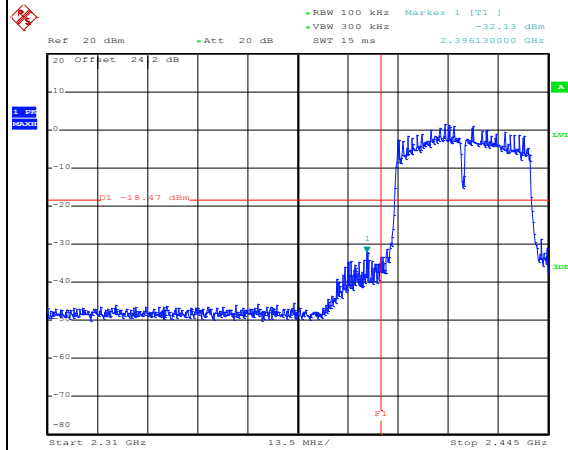

Date: 30.AUG.2016 19:31:42

Spurious Emission 30MHz~3GHz

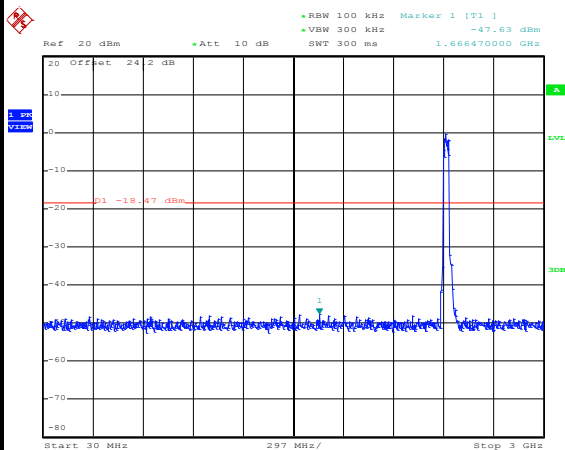

Date: 30.AUG.2016 19:33:19

Spurious Emission 2GHz~25GHz

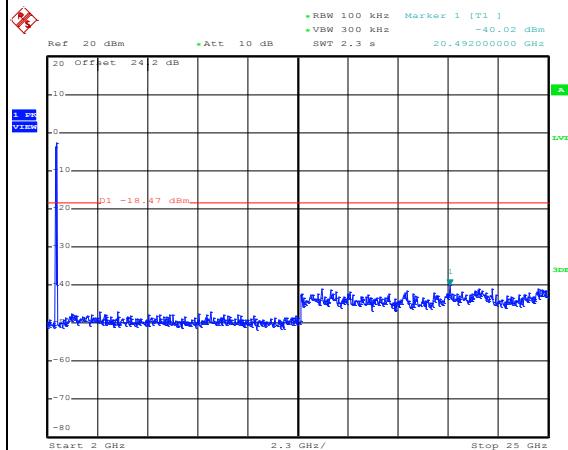

Date: 30.AUG.2016 19:33:27



Test Mode :	802.11n HT40	Temperature :	21~25°C
Test Band :	2.4GHz High	Relative Humidity :	51~54%
Test Channel :	09	Test Engineer :	Aking Chang and AC Chang

WLAN 802.11n HT40 Channel 09

100kHz PSD reference Level

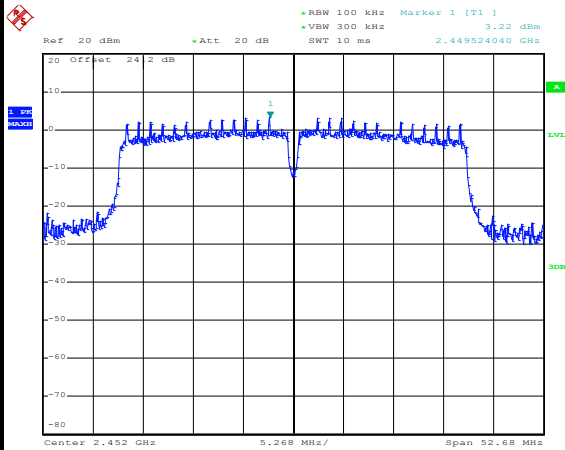

Date: 5.AUG.2016 15:02:21

High Channel Plot

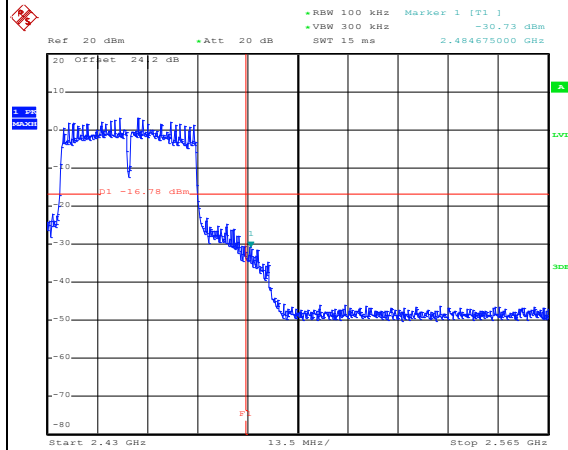

Date: 5.AUG.2016 15:02:34

Spurious Emission 30MHz~3GHz

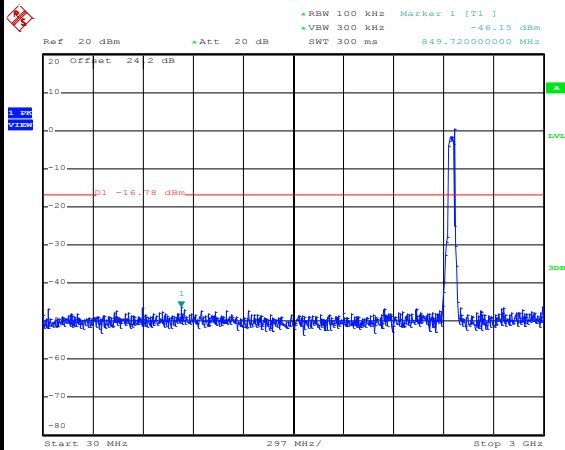

Date: 5.AUG.2016 15:04:09

Spurious Emission 2GHz~25GHz

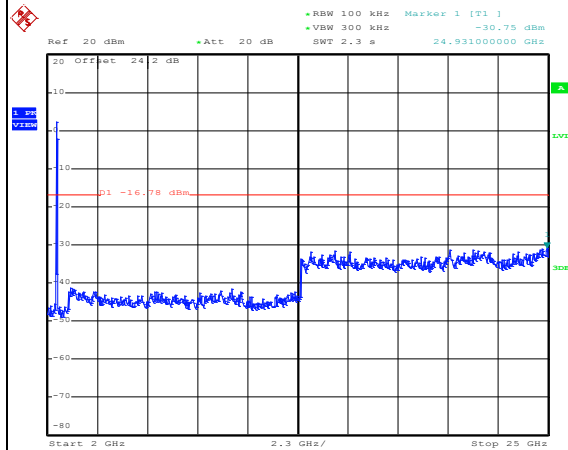

Date: 5.AUG.2016 15:04:18



3.5 Radiated Band Edges and Spurious Emission Measurement

3.5.1 Limit of Radiated band edge and Spurious Emission Measurement

In any 100 kHz bandwidth outside the intentional radiator frequency band, all harmonics/spurious must be at least 20 dB below the highest emission level within the authorized band. If the output power of this device was measured by spectrum analyzer, the attenuation under this paragraph shall be 30 dB instead of 20 dB. In addition, radiated emissions which fall in the restricted bands must also comply with the FCC section 15.209 limits as below.

Frequency (MHz)	Field Strength (microvolts/meter)	Measurement Distance (meters)
0.009 – 0.490	2400/F(kHz)	300
0.490 – 1.705	24000/F(kHz)	30
1.705 – 30.0	30	30
30 – 88	100	3
88 – 216	150	3
216 - 960	200	3
Above 960	500	3

3.5.2 Measuring Instruments

The measuring equipment is listed in the section 4 of this test report.



3.5.3 Test Procedures

1. The testing follows FCC KDB Publication No. 558074 D01 DTS Meas. Guidance v03r05.
2. The EUT was arranged to its worst case and then tune the antenna tower (from 1 m to 4 m) and turntable (from 0 degree to 360 degrees) to find the maximum reading. A pre-amp and a high pass filter are used for the test in order to get better signal level.
3. The EUT was placed on a turntable with 0.8 meter for frequency below 1GHz and 1.5 meter for frequency above 1GHz respectively above ground.
4. The EUT was set 3 meters from the interference receiving antenna, which was mounted on the top of a variable height antenna tower.
5. Corrected Reading: Antenna Factor + Cable Loss + Read Level - Preamp Factor = Level
6. For measurement below 1GHz, If the emission level of the EUT measured by the peak detector is 3 dB lower than the applicable limit, the peak emission level will be reported. Otherwise, the emission measurement will be repeated using the quasi-peak detector and reported.
7. Use the following spectrum analyzer settings:
 - (1) Span shall wide enough to fully capture the emission being measured;
 - (2) Set RBW=100 kHz for $f < 1$ GHz; VBW \geq RBW; Sweep = auto; Detector function = peak; Trace = max hold;
 - (3) Set RBW = 1 MHz, VBW= 3MHz for $f \geq 1$ GHz for peak measurement.
For average measurement:
 - VBW = 10 Hz, when duty cycle is no less than 98 percent.
 - VBW $\geq 1/T$, when duty cycle is less than 98 percent where T is the minimum transmission duration over which the transmitter is on and is transmitting at its maximum power control level for the tested mode of operation.

3.5.4 Test Setup

For radiated emissions below 30MHz

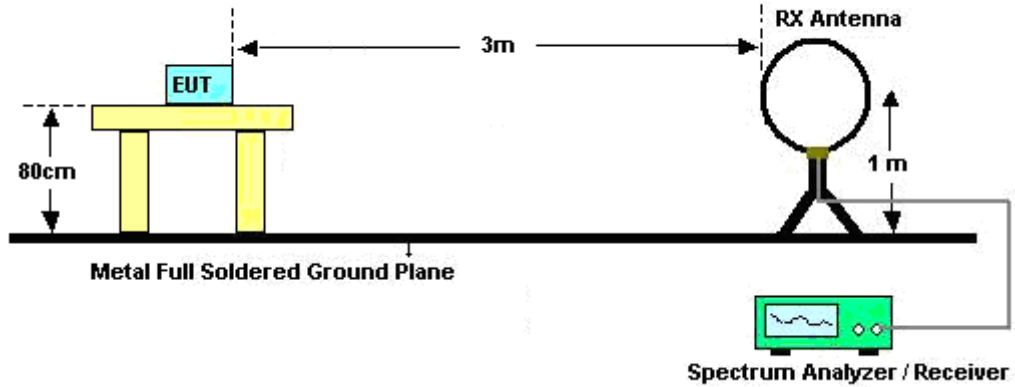

For radiated emissions from 30MHz to 1GHz

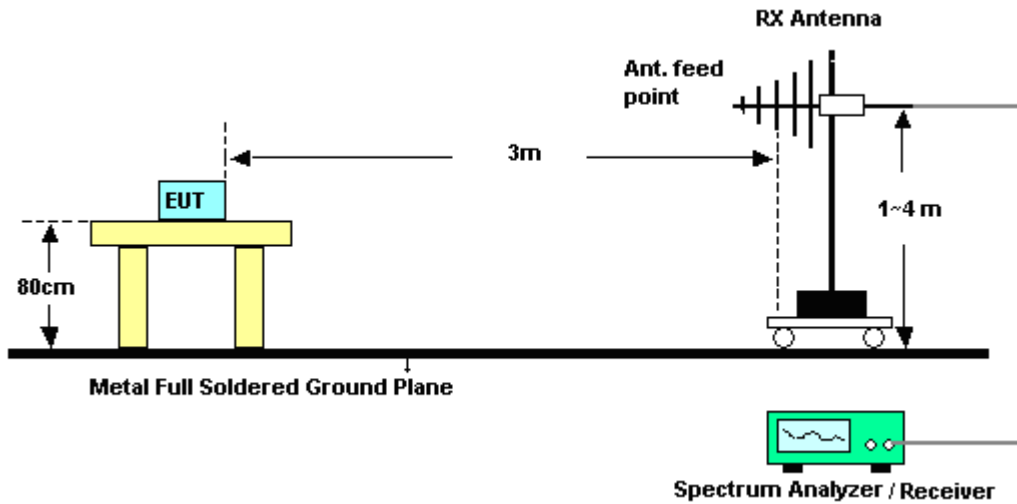

For radiated emissions above 1GHz

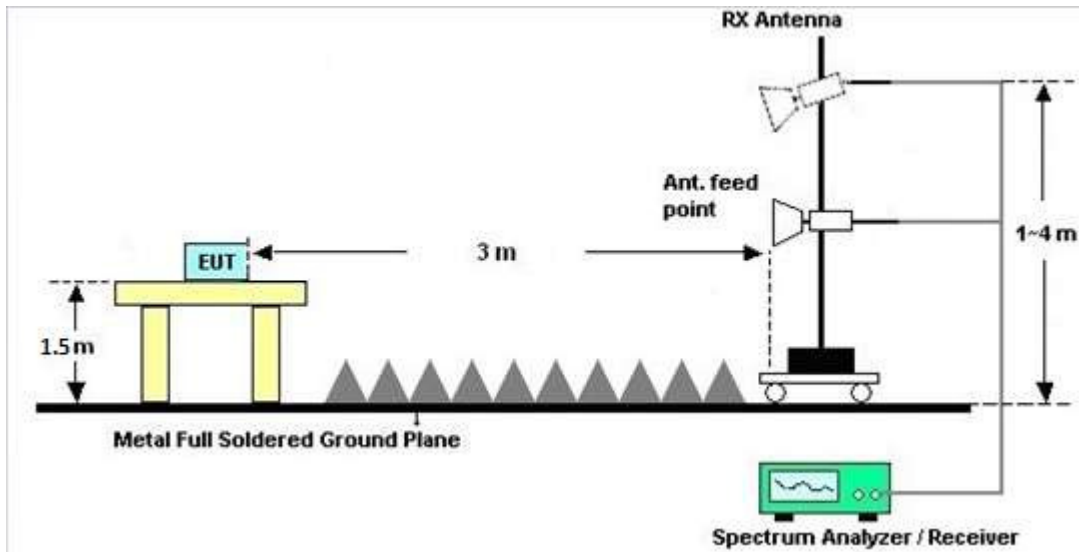

3.5.5 Test Results of Radiated Spurious Emissions (9kHz ~ 30MHz)

The low frequency, which started from 9 kHz to 30MHz, was pre-scanned and the result which was 20dB lower than the limit line per 15.31(o) was not reported.

3.5.6 Test Result of Radiated Spurious at Band Edges

Please refer to Appendix B and C.

3.5.7 Duty Cycle

Please refer to Appendix D.

3.5.8 Test Result of Radiated Spurious Emission (30MHz ~ 10th Harmonic)

Please refer to Appendix B and C.



3.6 AC Conducted Emission Measurement

3.6.1 Limit of AC Conducted Emission

For equipment that is designed to be connected to the public utility (AC) power line, the radio frequency voltage that is conducted back onto the AC power line on any frequency or frequencies within the band 150 kHz to 30 MHz shall not exceed the limits in the following table.

Frequency of Emission (MHz)	Conducted Limit (dB μ V)	
	Quasi-Peak	Average
0.15-0.5	66 to 56*	56 to 46*
0.5-5	56	46
5-30	60	50

*Decreases with the logarithm of the frequency.

For terminal test result, the testing follows FCC KDB 174176.

3.6.2 Measuring Instruments

The measuring equipment is listed in the section 4 of this test report.

3.6.3 Test Procedures

1. The EUT was placed 0.4 meter from the conducting wall of the shielding room, and it was kept at least 80 centimeters from any other grounded conducting surface.
2. Connect EUT to the power mains through a line impedance stabilization network (LISN).
3. All the support units are connecting to the other LISN.
4. The LISN provides 50 ohm coupling impedance for the measuring instrument.
5. The FCC states that a 50 ohm, 50 microhenry LISN should be used.
6. Both sides of AC line were checked for maximum conducted interference.
7. The frequency range from 150 kHz to 30 MHz was searched.
8. Set the test-receiver system to Peak Detect Function and specified bandwidth (IF bandwidth = 9kHz) with Maximum Hold Mode.

3.6.4 Test Setup

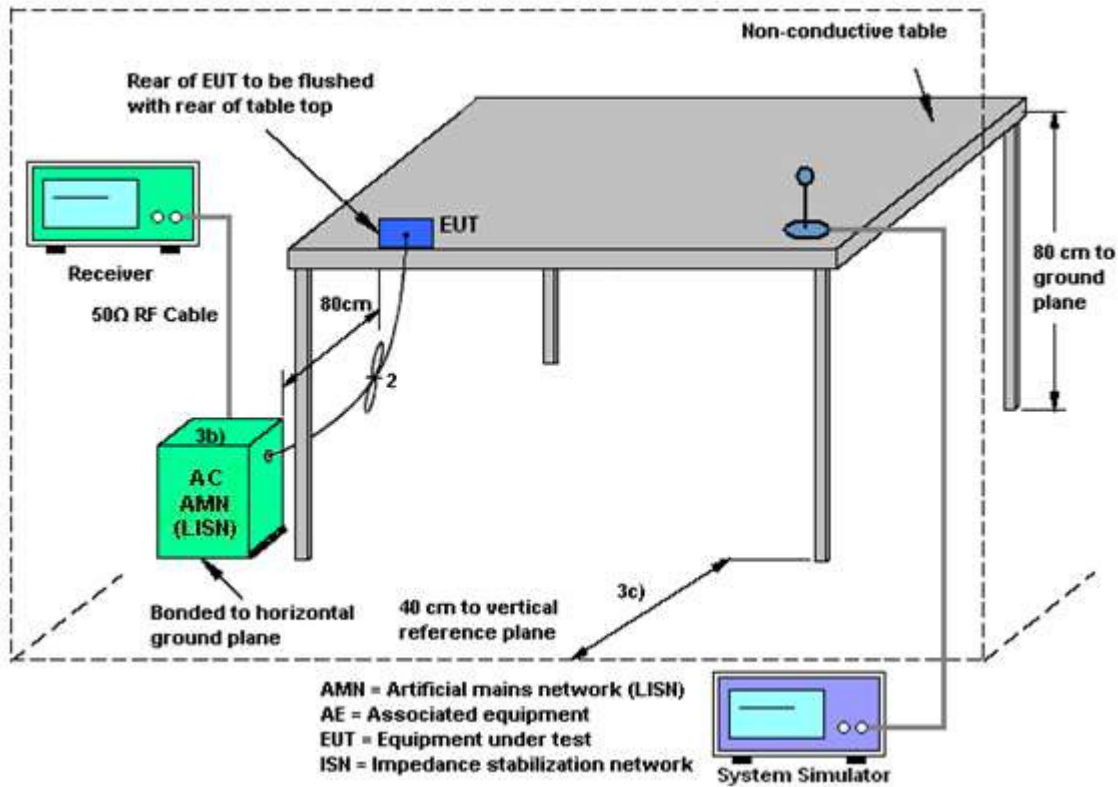



3.6.5 Test Result of AC Conducted Emission

Test Mode :	Mode 1	Temperature :	24~25°C
Test Engineer :	Kai-Chun Chu	Relative Humidity :	44~45%
Test Voltage :	120Vac / 60Hz	Phase :	Line
Function Type :	GSM850 Idle + Bluetooth Link + WLAN (5GHz) Link + USB Cable 2 (Charging from Adapter 2) + Earphone 2 + MP3 for Sample 1		

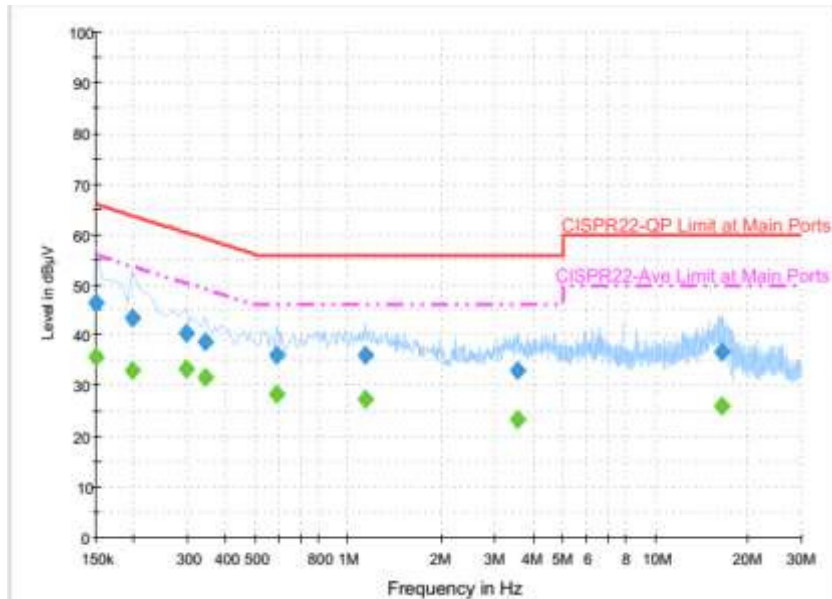

Final Result : Quasi-Peak

Frequency (MHz)	Quasi-Peak (dBµV)	Filter	Line	Corr. (dB)	Margin (dB)	Limit (dBµV)
0.150000	46.6	Off	L1	19.6	19.4	66.0
0.198000	43.6	Off	L1	19.6	20.1	63.7
0.294000	40.4	Off	L1	19.6	20.0	60.4
0.342000	38.6	Off	L1	19.6	20.6	59.2
0.582000	36.1	Off	L1	19.6	19.9	56.0
1.134000	36.0	Off	L1	19.7	20.0	56.0
3.542000	33.2	Off	L1	19.7	22.8	56.0
16.446000	36.9	Off	L1	20.5	23.1	60.0

Final Result : Average

Frequency (MHz)	Average (dBµV)	Filter	Line	Corr. (dB)	Margin (dB)	Limit (dBµV)
0.150000	35.9	Off	L1	19.6	20.1	56.0
0.198000	33.2	Off	L1	19.6	20.5	53.7
0.294000	33.5	Off	L1	19.6	16.9	50.4
0.342000	31.8	Off	L1	19.6	17.4	49.2
0.582000	28.4	Off	L1	19.6	17.6	46.0
1.134000	27.3	Off	L1	19.7	18.7	46.0
3.542000	23.4	Off	L1	19.7	22.6	46.0
16.446000	25.9	Off	L1	20.5	24.1	50.0



Test Mode :	Mode 1	Temperature :	24~25°C
Test Engineer :	Kai-Chun Chu	Relative Humidity :	44~45%
Test Voltage :	120Vac / 60Hz	Phase :	Neutral
Function Type :	GSM850 Idle + Bluetooth Link + WLAN (5GHz) Link + USB Cable 2 (Charging from Adapter 2) + Earphone 2 + MP3 for Sample 1		

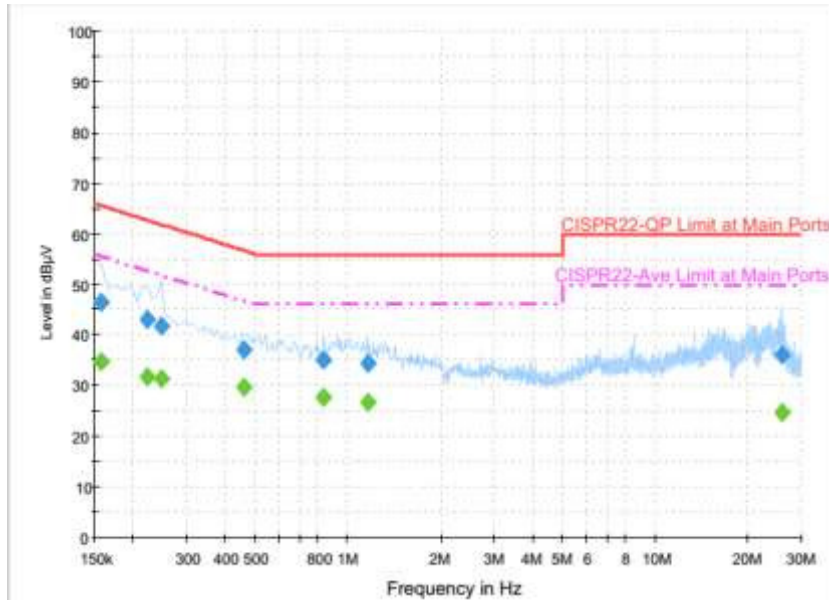

Final Result : Quasi-Peak

Frequency (MHz)	Quasi-Peak (dBµV)	Filter	Line	Corr. (dB)	Margin (dB)	Limit (dBµV)
0.158000	46.5	Off	N	19.6	19.1	65.6
0.222000	43.2	Off	N	19.6	19.5	62.7
0.246000	41.9	Off	N	19.6	20.0	61.9
0.462000	37.1	Off	N	19.6	19.6	56.7
0.838000	35.3	Off	N	19.6	20.7	56.0
1.158000	34.6	Off	N	19.6	21.4	56.0
25.854000	36.2	Off	N	21.1	23.8	60.0

Final Result : Average

Frequency (MHz)	Average (dBµV)	Filter	Line	Corr. (dB)	Margin (dB)	Limit (dBµV)
0.158000	34.9	Off	N	19.6	20.7	55.6
0.222000	31.9	Off	N	19.6	20.8	52.7
0.246000	31.3	Off	N	19.6	20.6	51.9
0.462000	29.7	Off	N	19.6	17.0	46.7
0.838000	27.8	Off	N	19.6	18.2	46.0
1.158000	26.7	Off	N	19.6	19.3	46.0
25.854000	24.9	Off	N	21.1	25.1	50.0



3.7 Antenna Requirements

3.7.1 Standard Applicable

If directional gain of transmitting antennas is greater than 6dBi, the power shall be reduced by the same level in dB comparing to gain minus 6dBi. For the fixed point-to-point operation, the power shall be reduced by one dB for every 3 dB that the directional gain of the antenna exceeds 6 dBi. The use of a permanently attached antenna or of an antenna that uses a unique coupling to the intentional radiator shall be considered sufficient to comply with the FCC rule.

3.7.2 Antenna Anti-Replacement Construction

An embedded-in antenna design is used.

3.7.3 Antenna Gain

The antenna peak gain of EUT is less than 6 dBi. Therefore, it is not necessary to reduce maximum peak output power limit.



4 List of Measuring Equipment

Instrument	Manufacturer	Model No.	Serial No.	Characteristics	Calibration Date	Test Date	Due Date	Remark
Power Meter	Anritsu	ML2495A	0932001	300MHz~40GHz	Oct. 05, 2015	Jul. 27, 2016 ~ Aug. 30, 2016	Oct. 04, 2016	Conducted (TH02-HY)
Power Sensor	Anritsu	MA2411B	1207349	300MHz~40GHz	Sep. 17, 2015	Jul. 27, 2016 ~ Aug. 30, 2016	Sep. 16, 2016	Conducted (TH02-HY)
Spectrum Analyzer	Rohde & Schwarz	FSP40	100057	9kHz-40GHz	Nov. 23, 2015	Jul. 27, 2016 ~ Aug. 30, 2016	Nov. 22, 2016	Conducted (TH02-HY)
Programmable Power Supply	GW Instek	PSS-2005	GEO82176 3	N/A	Nov. 13, 2015	Jul. 27, 2016 ~ Aug. 30, 2016	Nov. 12, 2016	Conducted (TH02-HY)
AC Power Source	ChainTek	APC-1000W	N/A	N/A	N/A	Aug. 30, 2016	N/A	Conduction (CO05-HY)
LISN	Rohde & Schwarz	ENV216	100080	9kHz~30MHz	Dec. 02, 2015	Aug. 30, 2016	Dec. 01, 2016	Conduction (CO05-HY)
LF Cable	HUBER + SUHNER	RG-214/U	LF01	N/A	Jan. 06, 2016	Aug. 30, 2016	Jan. 05, 2017	Conduction (CO05-HY)
EMI Test Receiver	Keysight	N9038A(MXE)	MY541300 85	20Hz ~ 8.4GHz	Nov. 04, 2015	Aug. 30, 2016	Nov. 03, 2016	Conduction (CO05-HY)
Loop Antenna	Rohde & Schwarz	HFH2-Z2	100315	9 kHz~30 MHz	Sep. 02, 2015	Aug. 20, 2016~ Aug. 26, 2016	Sep. 01, 2016	Radiation (03CH12-HY)
Loop Cable	Rohde & Schwarz	N/A	N/A	9KHz~30MHz	Dec. 03, 2015	Aug. 20, 2016~ Aug. 26, 2016	Dec. 02, 2016	Radiation (03CH12-HY)
Amplifier	SONOMA	310N	187312	9kHz~1GHz	Nov. 20, 2015	Aug. 20, 2016~ Aug. 26, 2016	Nov. 19, 2016	Radiation (03CH12-HY)
Bilog Antenna	TESEQ	CBL 6111D	37059	30MHz~1GHz	Dec. 29, 2015	Aug. 20, 2016~ Aug. 26, 2016	Dec. 28, 2016	Radiation (03CH12-HY)
EMI Test Receiver	Rohde & Schwarz	ESU26	100390	20Hz~26.5GHz	Dec. 21, 2015	Aug. 20, 2016~ Aug. 26, 2016	Dec. 20, 2016	Radiation (03CH12-HY)
Preamplifier	MITEQ	TTA0204	1872107	2GHz~40GHz	Feb. 15, 2016	Aug. 20, 2016~ Aug. 26, 2016	Feb. 14, 2017	Radiation (03CH12-HY)
Horn Antenna	SCHWARZBECK	BBHA 9120D	9120D-132 8	1GHz ~ 18GHz	Nov. 02, 2015	Aug. 20, 2016~ Aug. 26, 2016	Nov. 01, 2016	Radiation (03CH12-HY)
Preamplifier	MITEQ	AMF-7D-0010 1800-30-10P	1815698	1GHz~18GHz	Dec. 14, 2015	Aug. 20, 2016~ Aug. 26, 2016	Dec. 13, 2016	Radiation (03CH12-HY)
Preamplifier	Keysight	83017A	MY532701 48	1GHz~26.5GHz	Jan. 30, 2016	Aug. 20, 2016~ Aug. 26, 2016	Jan. 29, 2017	Radiation (03CH12-HY)
RF Cable	HUBER + SUHNER	SUCOFLEX 104	MY24958/ 4,MY2865 3/4,MY983 9/4PE	26GHz~40GHz	Jan. 12, 2016	Aug. 20, 2016~ Aug. 26, 2016	Jan. 11, 2017	Radiation (03CH12-HY)
RF Cable	HUBER + SUHNER	SUCOFLEX 104	MY24958/ 4,MY2865 3/4,MY983 9/4PE	1GHz~26GHz	Jan. 12, 2016	Aug. 20, 2016~ Aug. 26, 2016	Jan. 11, 2017	Radiation (03CH12-HY)



Instrument	Manufacturer	Model No.	Serial No.	Characteristics	Calibration Date	Test Date	Due Date	Remark
RF Cable	HUBER + SUHNER	SUCOFLEX 104	MY24958/4,MY2865 3/4,MY983 9/4PE	30MHz~1GHz	Jan. 12, 2016	Aug. 20, 2016~ Aug. 26, 2016	Jan. 11, 2017	Radiation (03CH12-HY)
RF Cable	HUBER + SUHNER	SUCOFLEX 104	MY24958/4,MY2865 3/4,MY983 9/4PE	9K~30MHz	Jan. 12, 2016	Aug. 20, 2016~ Aug. 26, 2016	Jan. 11, 2017	Radiation (03CH12-HY)
Antenna Mast	EMEC	AM-BS-4500-B	N/A	1m~4m	N/A	Aug. 20, 2016~ Aug. 26, 2016	N/A	Radiation (03CH12-HY)
Turn Table	EMEC	TT2000	N/A	0~360 Degree	N/A	Aug. 20, 2016~ Aug. 26, 2016	N/A	Radiation (03CH12-HY)
SHF-EHF Horn Antenna	SCHWARZBECK	BBHA 9170	BBHA9170 584	18GHz- 40GHz	Nov. 02, 2015	Aug. 20, 2016~ Aug. 26, 2016	Nov. 01, 2016	Radiation (03CH12-HY)



5 Uncertainty of Evaluation

Uncertainty of Conducted Emission Measurement (150 kHz ~ 30 MHz)

Measuring Uncertainty for a Level of Confidence of 95% ($U = 2Uc(y)$)	2.26
---	------

Uncertainty of Radiated Emission Measurement (30 MHz ~ 1000 MHz)

Measuring Uncertainty for a Level of Confidence of 95% ($U = 2Uc(y)$)	5.10
---	------

Uncertainty of Radiated Emission Measurement (1000 MHz ~ 18000 MHz)

Measuring Uncertainty for a Level of Confidence of 95% ($U = 2Uc(y)$)	5.20
---	------

Uncertainty of Radiated Emission Measurement (18000 MHz ~ 40000 MHz)

Measuring Uncertainty for a Level of Confidence of 95% ($U = 2Uc(y)$)	4.70
---	------



Appendix A. Conducted Test Results

A1 - DTS Part

Test Engineer:	Aking Chang and AC Chang	Temperature:	21~25	°C
Test Date:	8/2-8/5	Relative Humidity:	51~54	%

TEST RESULTS DATA
6dB and 99% Occupied Bandwidth

2.4GHz Band								
Mod.	Data Rate	N _{TX}	CH.	Freq. (MHz)	99% Occupied BW (MHz)	6dB BW (MHz)	6dB BW Limit (MHz)	Pass/Fail
11b	1Mbps	1	1	2412	12.55	9.56	0.50	Pass
11b	1Mbps	1	6	2437	12.80	10.02	0.50	Pass
11b	1Mbps	1	11	2462	12.70	10.02	0.50	Pass
11g	6Mbps	1	1	2412	17.55	15.44	0.50	Pass
11g	6Mbps	1	6	2437	17.65	15.34	0.50	Pass
11g	6Mbps	1	11	2462	17.75	15.54	0.50	Pass
HT20	MCS0	1	1	2412	18.15	15.40	0.50	Pass
HT20	MCS0	1	6	2437	18.50	15.46	0.50	Pass
HT20	MCS0	1	11	2462	18.40	15.94	0.50	Pass
HT40	MCS0	1	3	2422	36.00	35.12	0.50	Pass
HT40	MCS0	1	6	2437	36.60	35.16	0.50	Pass
HT40	MCS0	1	9	2452	36.60	35.12	0.50	Pass

TEST RESULTS DATA
Peak Power Table

2.4GHz Band										
Mod.	Data Rate	N _{TX}	CH.	Freq. (MHz)	Peak Conducted Power (dBm)	Conducted Power Limit (dBm)	DG (dBi)	EIRP Power (dBm)	EIRP Power Limit (dBm)	Pass /Fail
11b	1Mbps	1	1	2412	20.73	30.00	-2.00	18.73	36.00	Pass
11b	1Mbps	1	6	2437	20.83	30.00	-2.00	18.83	36.00	Pass
11b	1Mbps	1	11	2462	20.90	30.00	-2.00	18.90	36.00	Pass
11g	6Mbps	1	1	2412	24.00	30.00	-2.00	22.00	36.00	Pass
11g	6Mbps	1	6	2437	24.30	30.00	-2.00	22.30	36.00	Pass
11g	6Mbps	1	11	2462	24.28	30.00	-2.00	22.28	36.00	Pass
HT20	MCS0	1	1	2412	24.11	30.00	-2.00	22.11	36.00	Pass
HT20	MCS0	1	6	2437	24.29	30.00	-2.00	22.29	36.00	Pass
HT20	MCS0	1	11	2462	24.53	30.00	-2.00	22.53	36.00	Pass
HT40	MCS0	1	3	2422	24.81	30.00	-2.00	22.81	36.00	Pass
HT40	MCS0	1	6	2437	24.41	30.00	-2.00	22.41	36.00	Pass
HT40	MCS0	1	9	2452	24.92	30.00	-2.00	22.92	36.00	Pass

TEST RESULTS DATA
Average Power Table
(Reporting Only)

2.4GHz Band						
Mod.	Data Rate	N _{TX}	CH.	Freq. (MHz)	Duty Factor (dB)	Average Conducted Power (dBm)
11b	1Mbps	1	1	2412	0.00	17.94
11b	1Mbps	1	6	2437	0.00	17.95
11b	1Mbps	1	11	2462	0.00	17.99
11g	6Mbps	1	1	2412	0.13	16.87
11g	6Mbps	1	6	2437	0.13	17.18
11g	6Mbps	1	11	2462	0.13	17.17
HT20	MCS0	1	1	2412	0.12	16.88
HT20	MCS0	1	6	2437	0.12	17.36
HT20	MCS0	1	11	2462	0.12	17.35
HT40	MCS0	1	3	2422	0.21	15.29
HT40	MCS0	1	6	2437	0.21	16.81
HT40	MCS0	1	9	2452	0.21	16.54

TEST RESULTS DATA
Peak Power Density

2.4GHz Band								
Mod.	Data Rate	N _{TX}	CH.	Freq. (MHz)	Peak PSD (dBm /3kHz)	DG (dBi)	Peak PSD Limit (dBm /3kHz)	Pass/Fail
11b	1Mbps	1	1	2412	-4.55	-2.00	8.00	Pass
11b	1Mbps	1	6	2437	-4.72	-2.00	8.00	Pass
11b	1Mbps	1	11	2462	-5.12	-2.00	8.00	Pass
11g	6Mbps	1	1	2412	-6.45	-2.00	8.00	Pass
11g	6Mbps	1	6	2437	-6.98	-2.00	8.00	Pass
11g	6Mbps	1	11	2462	-7.74	-2.00	8.00	Pass
HT20	MCS0	1	1	2412	-7.51	-2.00	8.00	Pass
HT20	MCS0	1	6	2437	-8.21	-2.00	8.00	Pass
HT20	MCS0	1	11	2462	-8.32	-2.00	8.00	Pass
HT40	MCS0	1	3	2422	-12.35	-2.00	8.00	Pass
HT40	MCS0	1	6	2437	-10.84	-2.00	8.00	Pass
HT40	MCS0	1	9	2452	-10.30	-2.00	8.00	Pass



Appendix B. Radiated Spurious Emission

Test Engineer :	Karl Hou and Nick Yu and Peter Chiu	Temperature :	22~24°C
		Relative Humidity :	53~58%

2.4GHz 2400~2483.5MHz

WIFI 802.11b (Band Edge @ 3m)

WIFI	Note	Frequency	Level	Over	Limit	Read	Antenna	Cable	Preamp	Ant	Table	Peak	Pol.	
Ant.				Limit	Line	Level	Factor	Loss	Factor	Pos	Pos	Avg.		
1		(MHz)	(dBμV/m)	(dB)	(dBμV/m)	(dBμV)	(dB/m)	(dB)	(dB)	(cm)	(deg)	(P/A)	(H/V)	
802.11b CH 01 2412MHz		2357.565	55.88	-18.12	74	53.04	26.97	7.37	31.5	100	120	P	H	
		2390	44.07	-9.93	54	41.06	27.05	7.45	31.49	100	120	A	H	
	*	2412	103.96	-	-	100.91	27.09	7.45	31.49	100	120	P	H	
	*	2412	99.34	-	-	96.29	27.09	7.45	31.49	100	120	A	H	
													H	
														H
			2333.625	55.72	-18.28	74	53.04	26.89	7.3	31.51	400	97	P	V
			2390	43.83	-10.17	54	40.82	27.05	7.45	31.49	400	97	A	V
	*		2412	100.4	-	-	97.35	27.09	7.45	31.49	400	97	P	V
	*		2412	95.87	-	-	92.82	27.09	7.45	31.49	400	97	A	V
														V
														V
802.11b CH 06 2437MHz		2389.38	55.8	-18.2	74	52.79	27.05	7.45	31.49	100	119	P	H	
		2388.26	43.82	-10.18	54	40.81	27.05	7.45	31.49	100	119	A	H	
	*	2439	104.19	-	-	101	27.18	7.49	31.48	100	119	P	H	
	*	2439	99.52	-	-	96.33	27.18	7.49	31.48	100	119	A	H	
			2496.64	55.89	-18.11	74	52.52	27.3	7.53	31.46	100	119	P	H
			2486.07	43.9	-10.1	54	40.58	27.26	7.53	31.47	100	119	A	H
			2387.28	55.46	-18.54	74	52.45	27.05	7.45	31.49	395	93	P	V
			2389.1	43.65	-10.35	54	40.64	27.05	7.45	31.49	395	93	A	V
	*		2439	102.19	-	-	99	27.18	7.49	31.48	395	93	P	V
	*		2439	97.47	-	-	94.28	27.18	7.49	31.48	395	93	A	V
			2486.42	55.66	-18.34	74	52.34	27.26	7.53	31.47	395	93	P	V
			2485.86	43.76	-10.24	54	40.44	27.26	7.53	31.47	395	93	A	V



802.11b CH 11 2462MHz	*	2462	103.69	-	-	100.41	27.22	7.53	31.47	133	119	P	H
	*	2462	98.66	-	-	95.38	27.22	7.53	31.47	133	119	A	H
		2486.84	56.13	-17.87	74	52.81	27.26	7.53	31.47	133	119	P	H
		2486.04	44.67	-9.33	54	41.35	27.26	7.53	31.47	133	119	A	H
													H
													H
	*	2462	101.23	-	-	97.95	27.22	7.53	31.47	387	93	P	V
	*	2462	96.29	-	-	93.01	27.22	7.53	31.47	387	93	A	V
		2496.16	55.94	-18.06	74	52.57	27.3	7.53	31.46	387	93	P	V
		2486.16	44.32	-9.68	54	41	27.26	7.53	31.47	387	93	A	V
													V
													V
Remark	1. No other spurious found. 2. All results are PASS against Peak and Average limit line.												



2.4GHz 2400~2483.5MHz

WIFI 802.11b (Harmonic @ 3m)

WIFI Ant. 1	Note	Frequency (MHz)	Level (dBμV/m)	Over Limit (dB)	Limit Line (dBμV/m)	Read Level (dBμV)	Antenna Factor (dB/m)	Cable Loss (dB)	Preamp Factor (dB)	Ant Pos (cm)	Table Pos (deg)	Peak Avg. (P/A)	Pol. (H/V)
802.11b CH 01 2412MHz		4824	51.07	-22.93	74	67.21	31.26	10.74	58.14	115	125	P	H
		4824	47.82	-6.18	54	63.96	31.26	10.74	58.14	115	125	A	H
													H
													H
		4824	48.81	-25.19	74	64.95	31.26	10.74	58.14	100	0	P	V
													V
													V
802.11b CH 06 2437MHz		4872	54.82	-19.18	74	70.7	31.33	10.89	58.1	100	125	P	H
		4872	52.55	-1.45	54	68.43	31.33	10.89	58.1	100	125	A	H
		7308	43.23	-30.77	74	52.07	36.07	14.18	59.09	100	0	P	H
													H
		4872	53.39	-20.61	74	69.27	31.33	10.89	58.1	319	76	P	V
		4872	51.06	-2.94	54	66.94	31.33	10.89	58.1	319	76	A	V
		7308	43.55	-30.45	74	52.39	36.07	14.18	59.09	100	0	P	V
802.11b CH 11 2462MHz		4926	54.27	-19.73	74	69.89	31.4	11.04	58.06	100	124	P	H
		4926	51.74	-2.26	54	67.36	31.4	11.04	58.06	100	124	A	H
		7386	44.47	-29.53	74	53.03	36.31	14.27	59.14	100	0	P	H
													H
		4926	51.89	-22.11	74	67.51	31.4	11.04	58.06	322	65	P	V
		4926	49.72	-4.28	54	65.34	31.4	11.04	58.06	322	65	A	V
		7386	44.96	-29.04	74	53.52	36.31	14.27	59.14	100	0	P	V
												V	
Remark	1. No other spurious found. 2. All results are PASS against Peak and Average limit line.												



**2.4GHz 2400~2483.5MHz
WIFI 802.11g (Band Edge @ 3m)**

WIFI Ant. 1	Note	Frequency (MHz)	Level (dBμV/m)	Over Limit (dB)	Limit Line (dBμV/m)	Read Level (dBμV)	Antenna Factor (dB/m)	Cable Loss (dB)	Preamp Factor (dB)	Ant Pos (cm)	Table Pos (deg)	Peak Avg. (P/A)	Pol. (H/V)	
802.11g CH 01 2412MHz		2389.8	57.77	-16.23	74	54.76	27.05	7.45	31.49	148	116	P	H	
		2389.8	46.77	-7.23	54	43.76	27.05	7.45	31.49	148	116	A	H	
	*	2412	104.93	-	-	101.88	27.09	7.45	31.49	148	116	P	H	
	*	2412	96.38	-	-	93.33	27.09	7.45	31.49	148	116	A	H	
													H	
														H
			2390	55.92	-18.08	74	52.91	27.05	7.45	31.49	400	92	P	V
			2390	45.93	-8.07	54	42.92	27.05	7.45	31.49	400	92	A	V
	*		2412	103.64	-	-	100.59	27.09	7.45	31.49	400	92	P	V
	*		2412	94.31	-	-	91.26	27.09	7.45	31.49	400	92	A	V
														V
														V
802.11g CH 06 2437MHz		2365.3	55.74	-18.26	74	52.89	26.97	7.37	31.49	142	116	P	H	
		2389.24	45.68	-8.32	54	42.67	27.05	7.45	31.49	142	116	A	H	
	*	2439	105.18	-	-	101.99	27.18	7.49	31.48	142	116	P	H	
	*	2439	95.59	-	-	92.4	27.18	7.49	31.48	142	116	A	H	
			2489.92	55.88	-18.12	74	52.52	27.3	7.53	31.47	142	116	P	H
			2487.89	45.77	-8.23	54	42.41	27.3	7.53	31.47	142	116	A	H
			2388.26	56.58	-17.42	74	53.57	27.05	7.45	31.49	386	93	P	V
			2389.1	45.69	-8.31	54	42.68	27.05	7.45	31.49	386	93	A	V
	*		2438	103.73	-	-	100.54	27.18	7.49	31.48	386	93	P	V
	*		2438	94.45	-	-	91.26	27.18	7.49	31.48	386	93	A	V
			2491.53	55.61	-18.39	74	52.25	27.3	7.53	31.47	386	93	P	V
			2490.06	45.46	-8.54	54	42.1	27.3	7.53	31.47	386	93	A	V



802.11g CH 11 2462MHz	*	2462	104.45	-	-	101.17	27.22	7.53	31.47	140	116	P	H
	*	2462	94.92	-	-	91.64	27.22	7.53	31.47	140	116	A	H
		2483.8	62.64	-11.36	74	59.32	27.26	7.53	31.47	140	116	P	H
		2483.6	48.34	-5.66	54	45.02	27.26	7.53	31.47	140	116	A	H
													H
													H
	*	2460	102.99	-	-	99.75	27.22	7.49	31.47	386	93	P	V
	*	2460	93.68	-	-	90.44	27.22	7.49	31.47	386	93	A	V
		2484.04	61.17	-12.83	74	57.85	27.26	7.53	31.47	386	93	P	V
		2483.6	47.27	-6.73	54	43.95	27.26	7.53	31.47	386	93	A	V
													V
													V
Remark	1. No other spurious found. 2. All results are PASS against Peak and Average limit line.												



2.4GHz 2400~2483.5MHz

WIFI 802.11g (Harmonic @ 3m)

WIFI Ant. 1	Note	Frequency (MHz)	Level (dBμV/m)	Over Limit (dB)	Limit Line (dBμV/m)	Read Level (dBμV)	Antenna Factor (dB/m)	Cable Loss (dB)	Preamp Factor (dB)	Ant Pos (cm)	Table Pos (deg)	Peak Avg. (P/A)	Pol. (H/V)
802.11g CH 01 2412MHz		4824	47.36	-26.64	74	63.5	31.26	10.74	58.14	100	0	P	H
													H
													H
													H
		4824	45.41	-28.59	74	61.55	31.26	10.74	58.14	100	0	P	V
													V
													V
802.11g CH 06 2437MHz		4874	47.49	-26.51	74	63.37	31.33	10.89	58.1	100	0	P	H
		7311	44.04	-29.96	74	52.88	36.07	14.18	59.09	100	0	P	H
													H
													H
		4874	47.71	-26.29	74	63.59	31.33	10.89	58.1	100	0	P	V
		7311	49.37	-24.63	74	58.21	36.07	14.18	59.09	100	0	P	V
													V
802.11g CH 11 2462MHz		4926	47.87	-26.13	74	63.49	31.4	11.04	58.06	100	0	P	H
		7386	43.53	-30.47	74	52.09	36.31	14.27	59.14	100	0	P	H
													H
													H
		4926	47.54	-26.46	74	63.16	31.4	11.04	58.06	100	0	P	V
		7386	44.9	-29.1	74	53.46	36.31	14.27	59.14	100	0	P	V
													V
Remark	1. No other spurious found.												
	2. All results are PASS against Peak and Average limit line.												



2.4GHz 2400~2483.5MHz
WIFI 802.11n HT20 (Band Edge @ 3m)

WIFI Ant. 1	Note	Frequency (MHz)	Level (dBμV/m)	Over Limit (dB)	Limit Line (dBμV/m)	Read Level (dBμV)	Antenna Factor (dB/m)	Cable Loss (dB)	Preamp Factor (dB)	Ant Pos (cm)	Table Pos (deg)	Peak Avg. (P/A)	Pol. (H/V)	
802.11n HT20 CH 01 2412MHz		2389.59	58.45	-15.55	74	55.44	27.05	7.45	31.49	100	118	P	H	
		2390	46.27	-7.73	54	43.26	27.05	7.45	31.49	100	118	A	H	
	*	2412	104.25	-	-	101.2	27.09	7.45	31.49	100	118	P	H	
	*	2412	95.09	-	-	92.04	27.09	7.45	31.49	100	118	A	H	
													H	
														H
			2390	55.71	-18.29	74	52.7	27.05	7.45	31.49	400	98	P	V
			2389.59	45.17	-8.83	54	42.16	27.05	7.45	31.49	400	98	A	V
		*	2412	101.04	-	-	97.99	27.09	7.45	31.49	400	98	P	V
		*	2412	91.67	-	-	88.62	27.09	7.45	31.49	400	98	A	V
802.11n HT20 CH 06 2437MHz		2389.66	57	-17	74	53.99	27.05	7.45	31.49	100	119	P	H	
		2389.94	45.11	-8.89	54	42.1	27.05	7.45	31.49	100	119	A	H	
		*	2439	103.87	-	-	100.68	27.18	7.49	31.48	100	119	P	H
		*	2439	94.25	-	-	91.06	27.18	7.49	31.48	100	119	A	H
			2486.98	57.85	-16.15	74	54.53	27.26	7.53	31.47	100	119	P	H
			2484.11	45.08	-8.92	54	41.76	27.26	7.53	31.47	100	119	A	H
			2347.38	56.77	-17.23	74	53.97	26.93	7.37	31.5	394	97	P	V
			2384.2	44.62	-9.38	54	41.65	27.01	7.45	31.49	394	97	A	V
		*	2439	102.75	-	-	99.56	27.18	7.49	31.48	394	97	P	V
		*	2439	92.27	-	-	89.08	27.18	7.49	31.48	394	97	A	V
		2494.68	56.87	-17.13	74	53.5	27.3	7.53	31.46	394	97	P	V	
		2487.33	44.82	-9.18	54	41.5	27.26	7.53	31.47	394	97	A	V	



802.11n HT20 CH 11 2462MHz	*	2460	103.42	-	-	100.18	27.22	7.49	31.47	105	120	P	H
	*	2460	93.72	-	-	90.48	27.22	7.49	31.47	105	120	A	H
		2483.8	65.62	-8.38	74	62.3	27.26	7.53	31.47	105	120	P	H
		2483.52	48.66	-5.34	54	45.34	27.26	7.53	31.47	105	120	A	H
													H
													H
	*	2462	101.28	-	-	98	27.22	7.53	31.47	388	95	P	V
	*	2462	91.46	-	-	88.18	27.22	7.53	31.47	388	95	A	V
		2483.52	63.57	-10.43	74	60.25	27.26	7.53	31.47	388	95	P	V
		2483.68	47.25	-6.75	54	43.93	27.26	7.53	31.47	388	95	A	V
												V	
												V	
Remark	1. No other spurious found. 2. All results are PASS against Peak and Average limit line.												



2.4GHz 2400~2483.5MHz

WIFI 802.11n HT20 (Harmonic @ 3m)

WIFI Ant. 1	Note	Frequency (MHz)	Level (dBμV/m)	Over Limit (dB)	Limit Line (dBμV/m)	Read Level (dBμV)	Antenna Factor (dB/m)	Cable Loss (dB)	Preamp Factor (dB)	Ant Pos (cm)	Table Pos (deg)	Peak Avg. (P/A)	Pol. (H/V)	
802.11n HT20 CH 01 2412MHz		4824	46.21	-27.79	74	62.35	31.26	10.74	58.14	100	0	P	H	
													H	
													H	
													H	
			4824	46.26	-27.74	74	62.4	31.26	10.74	58.14	100	0	P	V
														V
														V
802.11n HT20 CH 06 2437MHz		4872	47.68	-26.32	74	63.56	31.33	10.89	58.1	100	0	P	H	
		7308	43.4	-30.6	74	52.24	36.07	14.18	59.09	100	0	P	H	
													H	
													H	
			4872	46.08	-27.92	74	61.96	31.33	10.89	58.1	100	0	P	V
			7308	46.82	-27.18	74	55.66	36.07	14.18	59.09	100	0	P	V
														V
802.11n HT20 CH 11 2462MHz		4926	48.21	-25.79	74	63.83	31.4	11.04	58.06	100	0	P	H	
		7386	43.44	-30.56	74	52	36.31	14.27	59.14	100	0	P	H	
													H	
													H	
			4926	47.23	-26.77	74	62.85	31.4	11.04	58.06	100	0	P	V
			7386	44.64	-29.36	74	53.2	36.31	14.27	59.14	100	0	P	V
														V
Remark	1. No other spurious found.													
	2. All results are PASS against Peak and Average limit line.													



2.4GHz 2400~2483.5MHz
WIFI 802.11n HT40 (Band Edge @ 3m)

WIFI Ant. 1	Note	Frequency (MHz)	Level (dBμV/m)	Over Limit (dB)	Limit Line (dBμV/m)	Read Level (dBμV)	Antenna Factor (dB/m)	Cable Loss (dB)	Preamp Factor (dB)	Ant Pos (cm)	Table Pos (deg)	Peak Avg. (P/A)	Pol. (H/V)
802.11n HT40 CH 03 2422MHz		2389.8	66.47	-7.53	74	63.46	27.05	7.45	31.49	100	118	P	H
		2389.94	53.07	-0.93	54	50.06	27.05	7.45	31.49	100	118	A	H
	*	2420	100.03	-	-	96.93	27.13	7.45	31.48	100	118	P	H
	*	2420	91.23	-	-	88.13	27.13	7.45	31.48	100	118	A	H
		2487.61	57.01	-16.99	74	53.65	27.3	7.53	31.47	100	118	P	H
		2496.43	45.78	-8.22	54	42.41	27.3	7.53	31.46	100	118	A	H
		2389.38	64.33	-9.67	74	61.32	27.05	7.45	31.49	400	98	P	V
		2389.52	50.89	-3.11	54	47.88	27.05	7.45	31.49	400	98	A	V
	*	2420	99.44	-	-	96.34	27.13	7.45	31.48	400	98	P	V
	*	2420	90.91	-	-	87.81	27.13	7.45	31.48	400	98	A	V
		2484.67	56.43	-17.57	74	53.11	27.26	7.53	31.47	400	98	P	V
		2497.55	45.55	-8.45	54	42.18	27.3	7.53	31.46	400	98	A	V
802.11n HT40 CH 06 2437MHz		2389.94	63.14	-10.86	74	60.13	27.05	7.45	31.49	100	121	P	H
		2389.94	51.16	-2.84	54	48.15	27.05	7.45	31.49	100	121	A	H
	*	2439	101.62	-	-	98.43	27.18	7.49	31.48	100	121	P	H
	*	2439	92.34	-	-	89.15	27.18	7.49	31.48	100	121	A	H
		2485.16	64.45	-9.55	74	61.13	27.26	7.53	31.47	100	121	P	H
		2484.11	50.23	-3.77	54	46.91	27.26	7.53	31.47	100	121	A	H
		2388.96	60.72	-13.28	74	57.71	27.05	7.45	31.49	386	96	P	V
		2389.94	47.96	-6.04	54	44.95	27.05	7.45	31.49	386	96	A	V
	*	2439	100.7	-	-	97.51	27.18	7.49	31.48	386	96	P	V
	*	2439	91.45	-	-	88.26	27.18	7.49	31.48	386	96	A	V
	2485.86	62.32	-11.68	74	59	27.26	7.53	31.47	386	96	P	V	
	2483.69	49.56	-4.44	54	46.24	27.26	7.53	31.47	386	96	A	V	



802.11n HT40 CH 09 2452MHz		2388.12	56.85	-17.15	74	53.84	27.05	7.45	31.49	100	120	P	H
		2388.82	45.24	-8.76	54	42.23	27.05	7.45	31.49	100	120	A	H
	*	2452	102.08	-	-	98.88	27.18	7.49	31.47	100	120	P	H
	*	2452	92.9	-	-	89.7	27.18	7.49	31.47	100	120	A	H
		2483.83	66.33	-7.67	74	63.01	27.26	7.53	31.47	100	120	P	H
		2483.5	52.68	-1.32	54	49.36	27.26	7.53	31.47	100	120	A	H
		2386.16	55.58	-18.42	74	52.57	27.05	7.45	31.49	385	95	P	V
		2389.8	45.46	-8.54	54	42.45	27.05	7.45	31.49	385	95	A	V
	*	2450	101.7	-	-	98.5	27.18	7.49	31.47	385	95	P	V
	*	2450	92.69	-	-	89.49	27.18	7.49	31.47	385	95	A	V
		2483.55	64.49	-9.51	74	61.17	27.26	7.53	31.47	385	95	P	V
		2483.5	52.19	-1.81	54	48.87	27.26	7.53	31.47	385	95	A	V
Remark	1. No other spurious found. 2. All results are PASS against Peak and Average limit line.												



2.4GHz 2400~2483.5MHz

WIFI 802.11n HT40 (Harmonic @ 3m)

WIFI Ant. 1	Note	Frequency (MHz)	Level (dBμV/m)	Over Limit (dB)	Limit Line (dBμV/m)	Read Level (dBμV)	Antenna Factor (dB/m)	Cable Loss (dB)	Preamp Factor (dB)	Ant Pos (cm)	Table Pos (deg)	Peak Avg. (P/A)	Pol. (H/V)
802.11n HT40 CH 03 2422MHz		4842	42	-32	74	58.1	31.28	10.74	58.12	100	0	P	H
		7266	42.45	-31.55	74	51.41	35.97	14.14	59.07	100	0	P	H
													H
													H
		4842	42.04	-31.96	74	58.14	31.28	10.74	58.12	100	0	P	V
		7266	45.27	-28.73	74	54.23	35.97	14.14	59.07	100	0	P	V
802.11n HT40 CH 06 2437MHz		4872	40.33	-33.67	74	56.21	31.33	10.89	58.1	100	0	P	H
		7311	43.31	-30.69	74	52.15	36.07	14.18	59.09	100	0	P	H
													H
													H
		4872	42.84	-31.16	74	58.72	31.33	10.89	58.1	100	0	P	V
		7311	45.07	-28.93	74	53.91	36.07	14.18	59.09	100	0	P	V
802.11n HT40 CH 09 2452MHz		4902	44.86	-29.14	74	60.51	31.38	11.04	58.07	100	0	P	H
		7356	43.26	-30.74	74	51.95	36.21	14.22	59.12	100	0	P	H
													H
													H
		4902	41.05	-32.95	74	56.7	31.38	11.04	58.07	100	0	P	V
		7356	46.21	-27.79	74	54.9	36.21	14.22	59.12	100	0	P	V
Remark	1. No other spurious found.												
	2. All results are PASS against Peak and Average limit line.												



2.4GHz 2400~2483.5MHz

Emission below 1GHz

2.4GHz WIFI 802.11n HT40 (LF)

WIFI Ant.	Note	Frequency	Level	Over Limit	Limit Line	Read Level	Antenna Factor	Cable Loss	Preamp Factor	Ant Pos	Table Pos	Peak Avg.	Pol.	
1		(MHz)	(dBμV/m)	(dB)	(dBμV/m)	(dBμV)	(dB/m)	(dB)	(dB)	(cm)	(deg)	(P/A)	(H/V)	
2.4GHz 802.11n HT40 LF		51.06	26.58	-13.42	40	43.67	14.59	0.78	32.46	-	-	P	H	
		107.49	28.58	-14.92	43.5	42.7	16.88	1.43	32.43	-	-	P	H	
		152.58	23.12	-20.38	43.5	36.39	17.4	1.75	32.42	-	-	P	H	
		529.6	23.25	-22.75	46	28.17	24.29	3.19	32.4	-	-	P	H	
		729.1	38.65	-7.35	46	40	27.11	3.89	32.35	100	0	P	H	
		929.3	30.78	-15.22	46	27.77	29.72	4.6	31.31	-	-	P	H	
														H
														H
														H
														H
														H
														H
			50.79	34.61	-5.39	40	51.39	14.9	0.78	32.46	100	0	P	V
			92.1	24.62	-18.88	43.5	40.95	15.04	1.06	32.43	-	-	P	V
			210.09	21.15	-22.35	43.5	35.74	16.1	1.7	32.39	-	-	P	V
			558.3	30.86	-15.14	46	35.3	24.66	3.3	32.4	-	-	P	V
			638.1	25.5	-20.5	46	28.43	25.86	3.61	32.4	-	-	P	V
			953.8	31.23	-14.77	46	27.32	30.25	4.75	31.09	-	-	P	V
													V	
													V	
													V	
													V	
													V	
													V	
Remark	1. No other spurious found. 2. All results are PASS against limit line.													



Note symbol

*	Fundamental Frequency which can be ignored. However, the level of any unwanted emissions shall not exceed the level of the fundamental frequency.
!	Test result is over limit line.
P/A	Peak or Average
H/V	Horizontal or Vertical



A calculation example for radiated spurious emission is shown as below:

WIFI	Note	Frequency	Level	Over	Limit	Read	Antenna	Cable	Preamp	Ant	Table	Peak	Pol.
Ant.				Limit	Line	Level	Factor	Loss	Factor	Pos	Pos	Avg.	
1		(MHz)	(dBμV/m)	(dB)	(dBμV/m)	(dBμV)	(dB/m)	(dB)	(dB)	(cm)	(deg)	(P/A)	(H/V)
802.11b		2390	55.45	-18.55	74	54.51	32.22	4.58	35.86	103	308	P	H
CH 01													
2412MHz		2390	43.54	-10.46	54	42.6	32.22	4.58	35.86	103	308	A	H

- Level(dBμV/m) =
Antenna Factor(dB/m) + Cable Loss(dB) + Read Level(dBμV) - Preamp Factor(dB)
- Over Limit(dB) = Level(dBμV/m) – Limit Line(dBμV/m)

For Peak Limit @ 2390MHz:

- Level(dBμV/m)
= Antenna Factor(dB/m) + Cable Loss(dB) + Read Level(dBμV) - Preamp Factor(dB)
= 32.22(dB/m) + 4.58(dB) + 54.51(dBμV) – 35.86 (dB)
= 55.45 (dBμV/m)
- Over Limit(dB)
= Level(dBμV/m) – Limit Line(dBμV/m)
= 55.45(dBμV/m) – 74(dBμV/m)
= -18.55(dB)

For Average Limit @ 2390MHz:

- Level(dBμV/m)
= Antenna Factor(dB/m) + Cable Loss(dB) + Read Level(dBμV) - Preamp Factor(dB)
= 32.22(dB/m) + 4.58(dB) + 42.6(dBμV) – 35.86 (dB)
= 43.54 (dBμV/m)
- Over Limit(dB)
= Level(dBμV/m) – Limit Line(dBμV/m)
= 43.54(dBμV/m) – 54(dBμV/m)
= -10.46(dB)

Both peak and average measured complies with the limit line, so test result is “PASS”.



Appendix C. Radiated Spurious Emission Plots

Test Engineer :	Karl Hou and Nick Yu and Peter Chiu	Temperature :	22~24°C
		Relative Humidity :	53~58%

Note symbol

-L	Low channel location
-R	High channel location



2.4GHz 2400~2483.5MHz

WIFI 802.11b (Band Edge @ 3m)

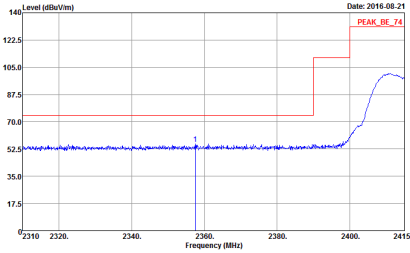
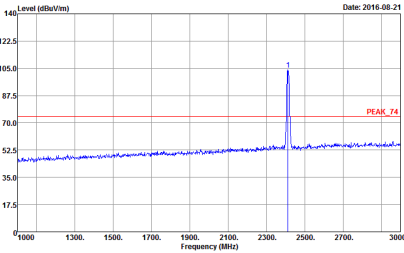
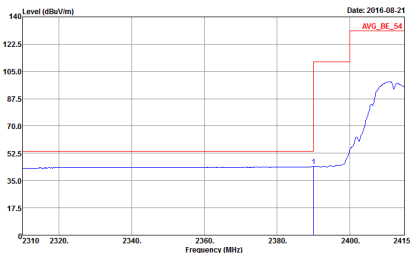
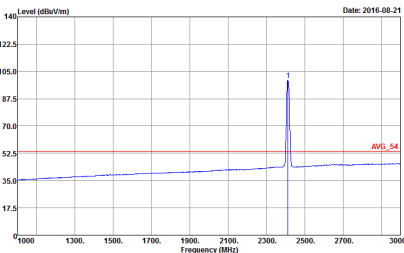
WIFI	2.4GHz 2400~2483.5MHz Band Edge @ 3m	
ANT	802.11b CH01 2412MHz	
1	Horizontal	Fundamental
Peak	 <p>Site : 03CH12-HY Condition : PEAK_BE_74 3m HORN_9120D_1328 HORIZONTAL Detector : Peak Project : 672509 Mode : 7 Setting : 20</p>	 <p>Site : 03CH12-HY Condition : PEAK_74 3m HORN_9120D_1328 HORIZONTAL Detector : Peak Project : 672509 Mode : 7 Setting : 20</p>
Avg.	 <p>Site : 03CH12-HY Condition : AVG_BE_54 3m HORN_9120D_1328 HORIZONTAL Detector : Peak Project : 672509 Mode : 7 Setting : 20</p>	 <p>Site : 03CH12-HY Condition : AVG_54 3m HORN_9120D_1328 HORIZONTAL Detector : Peak Project : 672509 Mode : 7 Setting : 20</p>

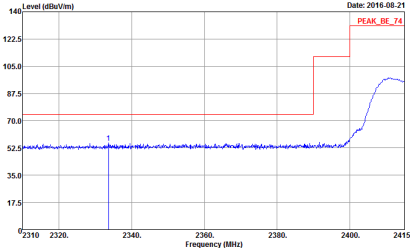
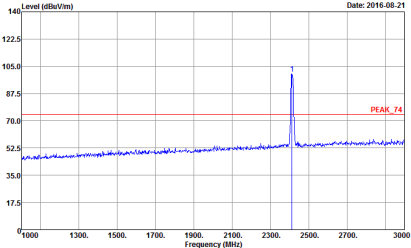
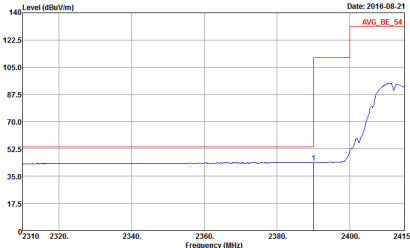
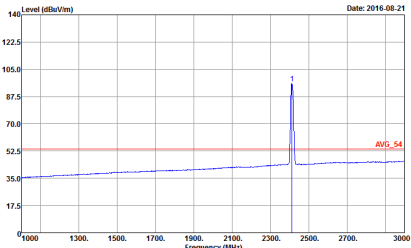

WIFI	2.4GHz 2400~2483.5MHz Band Edge @ 3m	
ANT	802.11b CH01 2412MHz	
1	<p style="text-align: center;">Vertical</p>  <p>Peak</p> <pre> Site : 03CH12-HY Condition : PEAK_BE_74 3m HORN_9120D_1328 VERTICAL : RBW:1000.000KHz VBW:3000.000KHz SWT:Auto Detector : Peak Project : 672509 Mode : 7 Setting : 20 </pre>	<p style="text-align: center;">Fundamental</p>  <pre> Site : 03CH12-HY Condition : PEAK_74 3m HORN_9120D_1328 VERTICAL : RBW:1000.000KHz VBW:3000.000KHz SWT:Auto Detector : Peak Project : 672509 Mode : 7 Setting : 20 </pre>
Avg.	 <pre> Site : 03CH12-HY Condition : AVG_BE_54 3m HORN_9120D_1328 VERTICAL : RBW:1000.000KHz VBW:0.010KHz SWT:Auto Detector : Peak Project : 672509 Mode : 7 Setting : 20 </pre>	 <pre> Site : 03CH12-HY Condition : AVG_54 3m HORN_9120D_1328 VERTICAL : RBW:1000.000KHz VBW:0.010KHz SWT:Auto Detector : Peak Project : 672509 Mode : 7 Setting : 20 </pre>

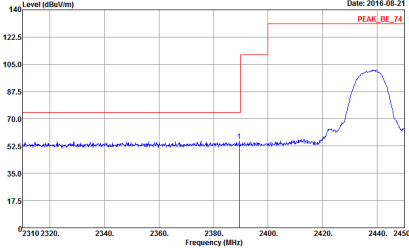
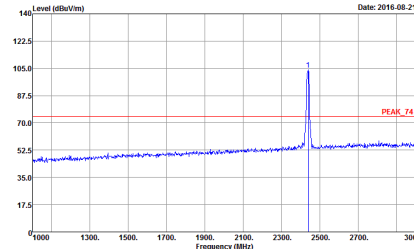
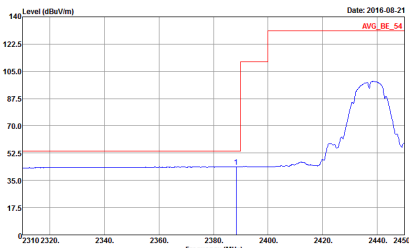
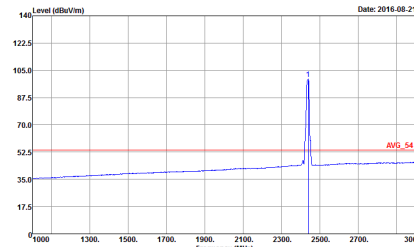

WIFI	2.4GHz 2400~2483.5MHz Band Edge @ 3m	
ANT	802.11b CH06 2437MHz - L	
1	Horizontal	Fundamental
Peak	 <p>Level (dBuV/m) vs Frequency (MHz) plot showing a peak at approximately 2437 MHz. The y-axis ranges from 0 to 140 dBuV/m, and the x-axis ranges from 2310 to 2450 MHz. A red horizontal line indicates the peak level at approximately 135 dBuV/m, labeled 'PEAK_BE_74'.</p> <p>Site : 03CH12-HY Condition : PEAK_BE_74 3m HORN_9120D_1328 HORIZONTAL : RBW:1000.000KHz VBW:3000.000KHz SWT:Auto Detector : Peak Project : 672509 Mode : B Setting : 20</p>	 <p>Level (dBuV/m) vs Frequency (MHz) plot showing a sharp peak at approximately 2437 MHz. The y-axis ranges from 0 to 140 dBuV/m, and the x-axis ranges from 1900 to 3000 MHz. A red horizontal line indicates the peak level at approximately 75 dBuV/m, labeled 'PEAK_I4'.</p> <p>Site : 03CH12-HY Condition : PEAK_I4 3m HORN_9120D_1328 HORIZONTAL : RBW:1000.000KHz VBW:3000.000KHz SWT:Auto Detector : Peak Project : 672509 Mode : B Setting : 20</p>
Avg.	 <p>Level (dBuV/m) vs Frequency (MHz) plot showing the average spectrum. The y-axis ranges from 0 to 140 dBuV/m, and the x-axis ranges from 2310 to 2450 MHz. A red horizontal line indicates the average level at approximately 55 dBuV/m, labeled 'AVG_BE_54'.</p> <p>Site : 03CH12-HY Condition : AVG_BE_54 3m HORN_9120D_1328 HORIZONTAL : RBW:1000.000KHz VBW:0.010KHz SWT:Auto Detector : Peak Project : 672509 Mode : B Setting : 20</p>	 <p>Level (dBuV/m) vs Frequency (MHz) plot showing the average spectrum. The y-axis ranges from 0 to 140 dBuV/m, and the x-axis ranges from 1900 to 3000 MHz. A red horizontal line indicates the average level at approximately 55 dBuV/m, labeled 'AVG_54'.</p> <p>Site : 03CH12-HY Condition : AVG_54 3m HORN_9120D_1328 HORIZONTAL : RBW:1000.000KHz VBW:0.010KHz SWT:Auto Detector : Peak Project : 672509 Mode : B Setting : 20</p>

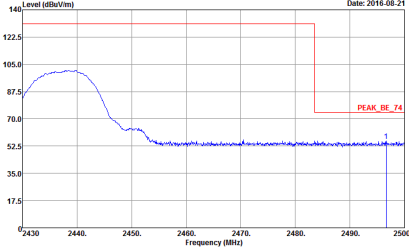
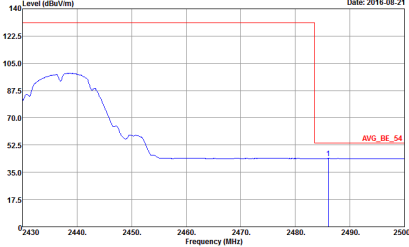

WIFI	2.4GHz 2400~2483.5MHz Band Edge @ 3m	
ANT	802.11b CH06 2437MHz - R	
1	Horizontal	Fundamental
Peak	 <p>Date: 2016-08-21</p> <p>Site : 03CH12-HY Condition : PEAK_BE_74 3m HORN_9120D_1328 HORIZONTAL RBW:1000.000KHz VBW:3000.000KHz SWT:Auto Detector : Peak Project : 672509 Mode : S Setting : 20</p>	Left blank
Avg.	 <p>Date: 2016-08-21</p> <p>Site : 03CH12-HY Condition : AVG_BE_54 3m HORN_9120D_1328 HORIZONTAL RBW:1000.000KHz VBW:0.0100KHz SWT:Auto Detector : Peak Project : 672509 Mode : S Setting : 20</p>	Left blank

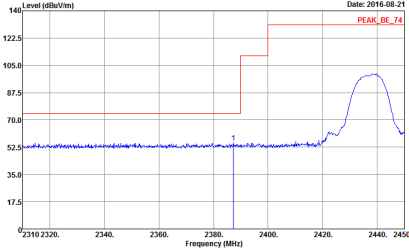
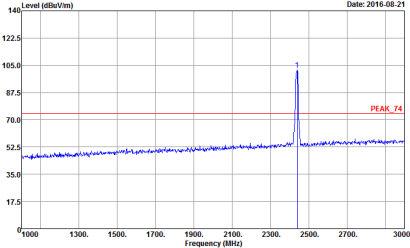
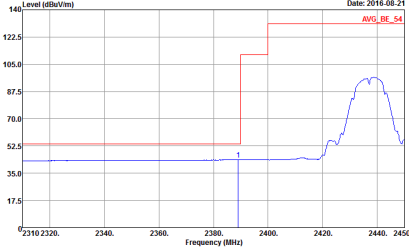
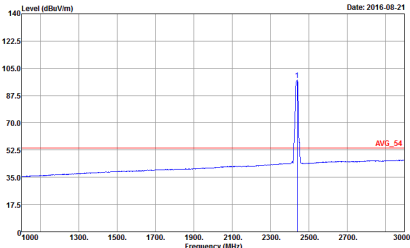

WIFI	2.4GHz 2400~2483.5MHz Band Edge @ 3m	
ANT	802.11b CH06 2437MHz - L	
1	<p style="text-align: center;">Vertical</p> <div style="display: flex; justify-content: space-between;"> <div style="width: 45%;"> <p>Peak</p>  <p style="font-size: small;">Date: 2016-08-21 PEAK_BE_74</p> <p style="font-size: x-small;">Site : 03CH12-HY Condition : PEAK_BE_74 3m HORN_9120D_1328 VERTICAL RBW:1000.000KHz VBW:3000.000KHz SWT:Auto Detector : Peak Project : 672509 Mode : B Setting : 20</p> </div> <div style="width: 45%;"> <p>Fundamental</p>  <p style="font-size: small;">Date: 2016-08-21 PEAK_74</p> <p style="font-size: x-small;">Site : 03CH12-HY Condition : PEAK_74 3m HORN_9120D_1328 VERTICAL RBW:1000.000KHz VBW:3000.000KHz SWT:Auto Detector : Peak Project : 672509 Mode : B Setting : 20</p> </div> </div>	
	<p style="text-align: center;">Vertical</p> <div style="display: flex; justify-content: space-between;"> <div style="width: 45%;"> <p>Avg.</p>  <p style="font-size: small;">Date: 2016-08-21 AVG_BE_54</p> <p style="font-size: x-small;">Site : 03CH12-HY Condition : AVG_BE_54 3m HORN_9120D_1328 VERTICAL RBW:1000.000KHz VBW:0.010KHz SWT:Auto Detector : Peak Project : 672509 Mode : B Setting : 20</p> </div> <div style="width: 45%;"> <p>Fundamental</p>  <p style="font-size: small;">Date: 2016-08-21 AVG_54</p> <p style="font-size: x-small;">Site : 03CH12-HY Condition : AVG_54 3m HORN_9120D_1328 VERTICAL RBW:1000.000KHz VBW:0.010KHz SWT:Auto Detector : Peak Project : 672509 Mode : B Setting : 20</p> </div> </div>	

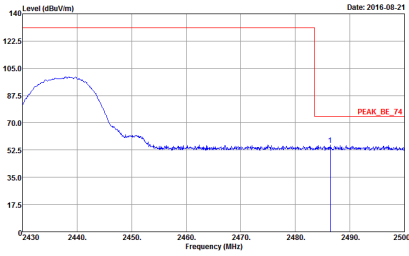
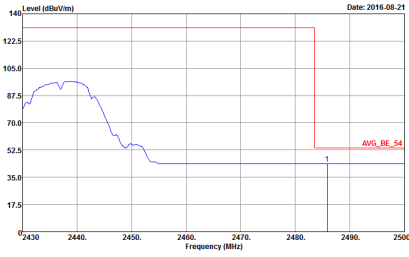

WIFI	2.4GHz 2400~2483.5MHz Band Edge @ 3m	
ANT	802.11b CH06 2437MHz - R	
1	Vertical	Fundamental
<p>Peak</p>	 <p>Date: 2016-08-21</p> <p>Site : 03CH12-HY Condition : PEAK_BE_74 3m HORN_9120D_1328 VERTICAL RBW:1000.000KHz VBW:3000.000KHz SWT:Auto Detector : Peak Project : 672509 Mode : 8 Setting : 20</p>	<p>Left blank</p>
<p>Avg.</p>	 <p>Date: 2016-08-21</p> <p>Site : 03CH12-HY Condition : AVG_BE_54 3m HORN_9120D_1328 VERTICAL RBW:1000.000KHz VBW:0.010KHz SWT:Auto Detector : Peak Project : 672509 Mode : 8 Setting : 20</p>	<p>Left blank</p>

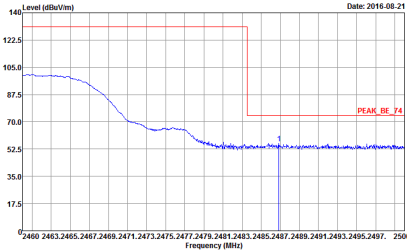
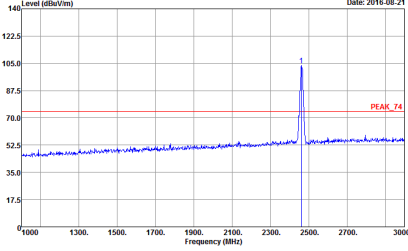
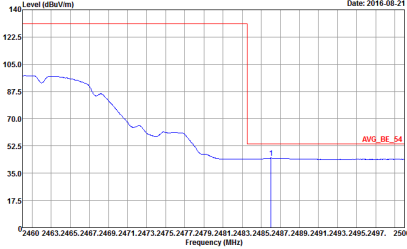
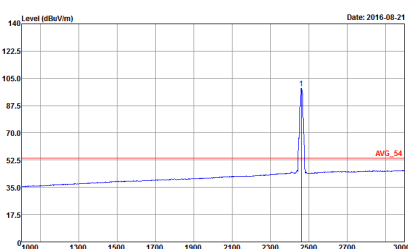

WIFI	2.4GHz 2400~2483.5MHz Band Edge @ 3m	
ANT	802.11b CH11 2462MHz	
1	Horizontal	Fundamental
Peak	 <p>Date: 2016-08-21</p> <p>Level (dBuV/m) vs Frequency (MHz)</p> <p>Site : 03CH12-HY Condition : PEAK_BE_74 3m HORN_9120D_1328 HORIZONTAL : RBW:1000.000KHz VBW:3000.000KHz SWT:Auto Detector : Peak Project : 672509 Mode : 9 Setting : 20</p>	 <p>Date: 2016-08-21</p> <p>Level (dBuV/m) vs Frequency (MHz)</p> <p>Site : 03CH12-HY Condition : PEAK_74 3m HORN_9120D_1328 HORIZONTAL : RBW:1000.000KHz VBW:3000.000KHz SWT:Auto Detector : Peak Project : 672509 Mode : 9 Setting : 20</p>
Avg.	 <p>Date: 2016-08-21</p> <p>Level (dBuV/m) vs Frequency (MHz)</p> <p>Site : 03CH12-HY Condition : AVG_BE_54 3m HORN_9120D_1328 HORIZONTAL : RBW:1000.000KHz VBW:0.010KHz SWT:Auto Detector : Peak Project : 672509 Mode : 9 Setting : 20</p>	 <p>Date: 2016-08-21</p> <p>Level (dBuV/m) vs Frequency (MHz)</p> <p>Site : 03CH12-HY Condition : AVG_54 3m HORN_9120D_1328 HORIZONTAL : RBW:1000.000KHz VBW:0.010KHz SWT:Auto Detector : Peak Project : 672509 Mode : 9 Setting : 20</p>

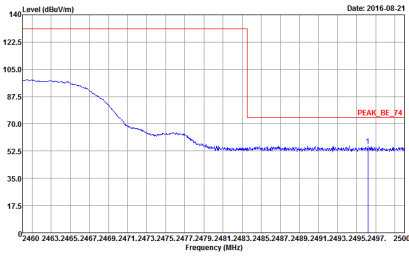
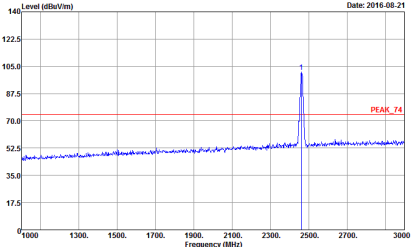
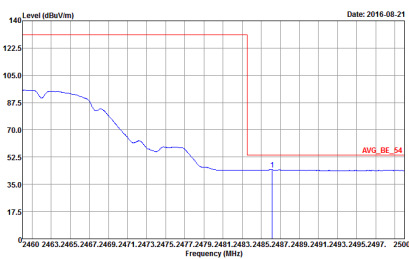
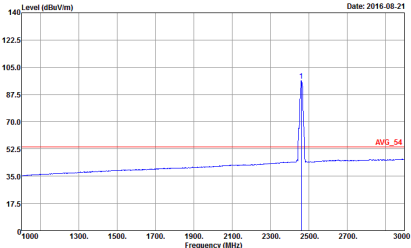

WIFI	2.4GHz 2400~2483.5MHz Band Edge @ 3m	
ANT	802.11b CH11 2462MHz	
<p style="text-align: center;">1</p>	<p style="text-align: center;">Vertical</p>  <p style="text-align: center;">Peak</p> <pre> Site : :03CH12-HY Condition : :PEAK_BE_74 3m HORN_9120D_1328 VERTICAL : :RBW:1000.000KHz VBW:3000.000KHz SWT:Auto Detector : :Peak Project : :672509 Mode : :9 Setting : :20 </pre>	<p style="text-align: center;">Fundamental</p>  <pre> Site : :03CH12-HY Condition : :PEAK_74 3m HORN_9120D_1328 VERTICAL : :RBW:1000.000KHz VBW:3000.000KHz SWT:Auto Detector : :Peak Project : :672509 Mode : :9 Setting : :20 </pre>
<p style="text-align: center;">Avg.</p>	 <pre> Site : :03CH12-HY Condition : :AVG_BE_54 3m HORN_9120D_1328 VERTICAL : :RBW:1000.000KHz VBW:0.010KHz SWT:Auto Detector : :Peak Project : :672509 Mode : :9 Setting : :20 </pre>	 <pre> Site : :03CH12-HY Condition : :AVG_54 3m HORN_9120D_1328 VERTICAL : :RBW:1000.000KHz VBW:0.010KHz SWT:Auto Detector : :Peak Project : :672509 Mode : :9 Setting : :20 </pre>



2.4GHz 2400~2483.5MHz

WIFI 802.11g (Band Edge @ 3m)

WIFI	2.4GHz 2400~2483.5MHz Band Edge @ 3m	
ANT	802.11g CH01 2412MHz	
1	Horizontal	Fundamental
Peak	<p>Date: 2016-08-20</p> <p>Site Condition : 03CH12-HY : PEAK_BE_74 3m HORN_9120D_1328 HORIZONTAL : RBW:1000.000KHz VBW:3000.000KHz SWT:Auto</p> <p>Detector : Peak Project : 672509 Mode : 10 Setting : 19</p>	<p>Date: 2016-08-20</p> <p>Site Condition : 03CH12-HY : PEAK_74 3m HORN_9120D_1328 HORIZONTAL : RBW:1000.000KHz VBW:3000.000KHz SWT:Auto</p> <p>Detector : Peak Project : 672509 Mode : 10 Setting : 19</p>
Avg.	<p>Date: 2016-08-20</p> <p>Site Condition : 03CH12-HY : AVG_BE_54 3m HORN_9120D_1328 HORIZONTAL : RBW:1000.000KHz VBW:3.000KHz SWT:Auto</p> <p>Detector : Peak Project : 672509 Mode : 10 Setting : 19</p>	<p>Date: 2016-08-20</p> <p>Site Condition : 03CH12-HY : AVG_54 3m HORN_9120D_1328 HORIZONTAL : RBW:1000.000KHz VBW:3.000KHz SWT:Auto</p> <p>Detector : Peak Project : 672509 Mode : 10 Setting : 19</p>

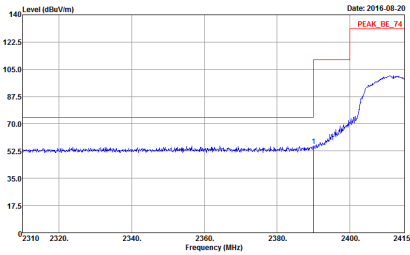
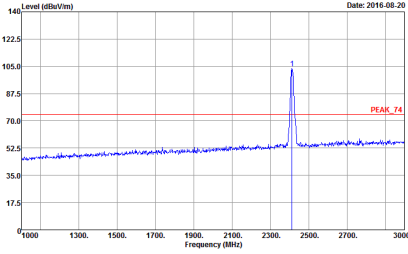
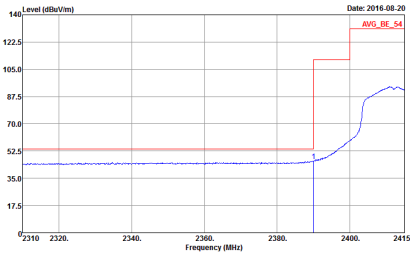
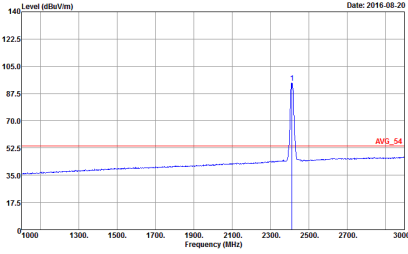

WIFI	2.4GHz 2400~2483.5MHz Band Edge @ 3m	
ANT	802.11g CH01 2412MHz	
1	<p style="text-align: center;">Vertical</p>  <p>Peak</p> <pre> Site : 03CH12-HY Condition : PEAK_BE_74 3m HORN_9120D_1328 VERTICAL Detector : Peak Project : 672509 Mode : 10 Setting : 19 </pre>	<p style="text-align: center;">Fundamental</p>  <pre> Site : 03CH12-HY Condition : PEAK_74 3m HORN_9120D_1328 VERTICAL Detector : Peak Project : 672509 Mode : 10 Setting : 19 </pre>
Avg.	 <p>Avg.</p> <pre> Site : 03CH12-HY Condition : AVG_BE_54 3m HORN_9120D_1328 VERTICAL Detector : Peak Project : 672509 Mode : 10 Setting : 19 </pre>	 <pre> Site : 03CH12-HY Condition : AVG_54 3m HORN_9120D_1328 VERTICAL Detector : Peak Project : 672509 Mode : 10 Setting : 19 </pre>

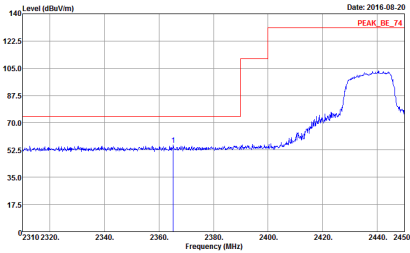
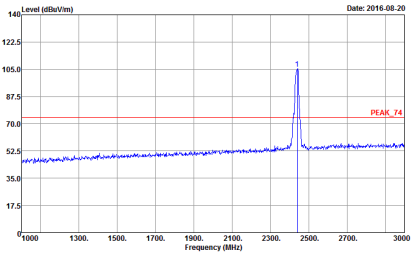
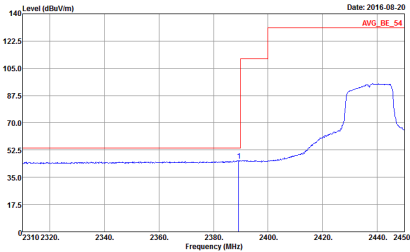
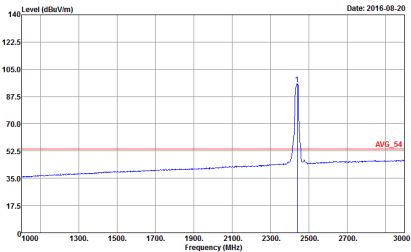

WIFI	2.4GHz 2400~2483.5MHz Band Edge @ 3m	
ANT	802.11g CH06 2437MHz - L	
1	<p style="text-align: center;">Horizontal</p>  <p>Peak</p> <pre> Site : 03CH12-HY Condition : PEAK_BE_74 3m HORN_9120D_1328 HORIZONTAL Detector : RBW:1000.000kHz VBW:3000.000kHz SWT:Auto Project : Peak Mode : 672509 Setting : 11 : 19 </pre>	<p style="text-align: center;">Fundamental</p>  <pre> Site : 03CH12-HY Condition : PEAK_74 3m HORN_9120D_1328 HORIZONTAL Detector : RBW:1000.000kHz VBW:3000.000kHz SWT:Auto Project : Peak Mode : 672509 Setting : 11 : 19 </pre>
Avg.	 <pre> Site : 03CH12-HY Condition : AVG_BE_54 3m HORN_9120D_1328 HORIZONTAL Detector : RBW:1000.000kHz VBW:3.000kHz SWT:Auto Project : Peak Mode : 672509 Setting : 11 : 19 </pre>	 <pre> Site : 03CH12-HY Condition : AVG_54 3m HORN_9120D_1328 HORIZONTAL Detector : RBW:1000.000kHz VBW:3.000kHz SWT:Auto Project : Peak Mode : 672509 Setting : 11 : 19 </pre>

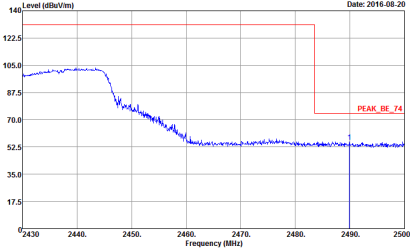
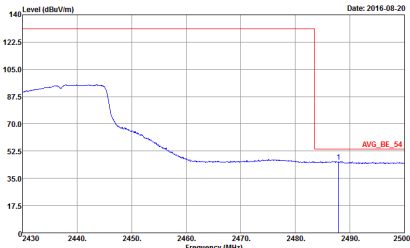

WIFI	2.4GHz 2400~2483.5MHz Band Edge @ 3m	
ANT	802.11g CH06 2437MHz - R	
1	Horizontal	Fundamental
Peak	 <p>Site : 03CH12-HY Condition : PEAK_BE_74 3m HORN_9120D_1328 HORIZONTAL RBW:1000.000KHz VBW:3000.000KHz SWT:Auto Detector : Peak Project : 672509 Mode : 11 Setting : 19</p>	Left blank
Avg.	 <p>Site : 03CH12-HY Condition : AVG_BE_54 3m HORN_9120D_1328 HORIZONTAL RBW:1000.000KHz VBW:3.000KHz SWT:Auto Detector : Peak Project : 672509 Mode : 11 Setting : 19</p>	Left blank

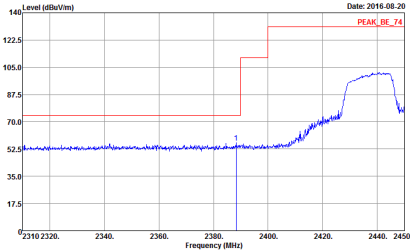
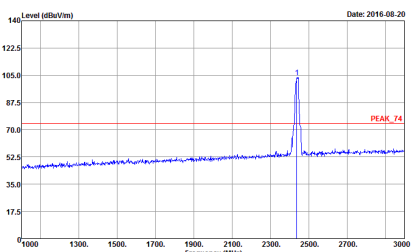
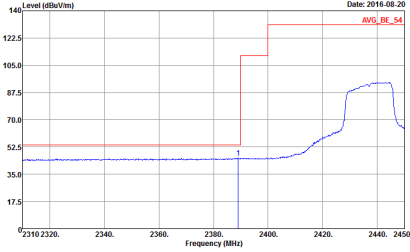
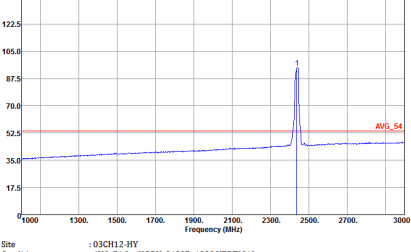

WIFI	2.4GHz 2400~2483.5MHz Band Edge @ 3m	
ANT	802.11g CH06 2437MHz - L	
1	<p style="text-align: center;">Vertical</p>  <p>Site : 03CH12-HY Condition : PEAK_BE_74 3m HORN_9120D_1328 VERTICAL RBW:1000.000KHz VBW:3000.000KHz SWT:Auto Detector : Peak Project : 672509 Mode : 11 Setting : 19</p>	<p style="text-align: center;">Fundamental</p>  <p>Site : 03CH12-HY Condition : PEAK_74 3m HORN_9120D_1328 VERTICAL RBW:1000.000KHz VBW:3000.000KHz SWT:Auto Detector : Peak Project : 672509 Mode : 11 Setting : 19</p>
Avg.	 <p>Site : 03CH12-HY Condition : AVG_BE_54 3m HORN_9120D_1328 VERTICAL RBW:1000.000KHz VBW:3.000KHz SWT:Auto Detector : Peak Project : 672509 Mode : 11 Setting : 19</p>	 <p>Site : 03CH12-HY Condition : AVG_54 3m HORN_9120D_1328 VERTICAL RBW:1000.000KHz VBW:3.000KHz SWT:Auto Detector : Peak Project : 672509 Mode : 11 Setting : 19</p>

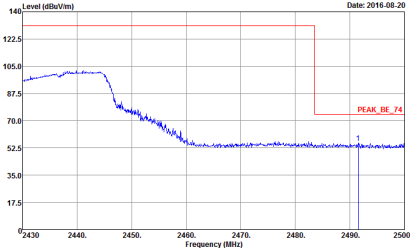
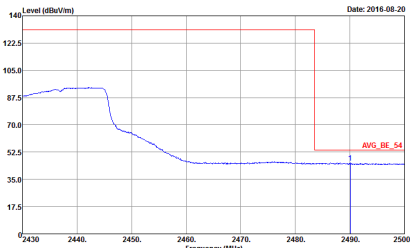

WIFI	2.4GHz 2400~2483.5MHz Band Edge @ 3m	
ANT	802.11g CH06 2437MHz - R	
1	Vertical	Fundamental
Peak	 <p>Date: 2016-08-20</p> <p>Site : 03CH12-HY Condition : PEAK_BE_74 3m HORN_9120D_1328 VERTICAL RBW:1000.000KHz VBW:3000.000KHz SWT:Auto Detector : Peak Project : 672509 Mode : 11 Setting : 19</p>	Left Blank
Avg.	 <p>Date: 2016-08-20</p> <p>Site : 03CH12-HY Condition : AVG_BE_54 3m HORN_9120D_1328 VERTICAL RBW:1000.000KHz VBW:3.000KHz SWT:Auto Detector : Peak Project : 672509 Mode : 11 Setting : 19</p>	Left Blank

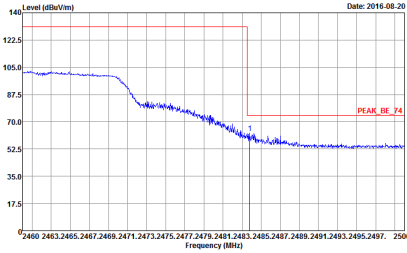
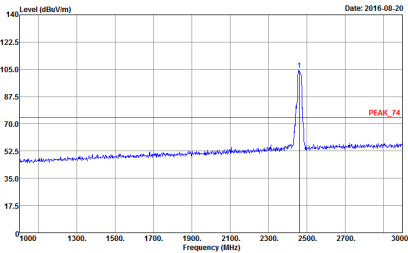
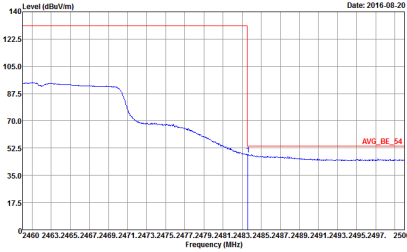
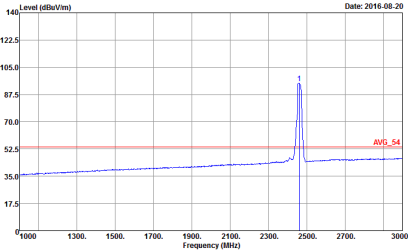

WIFI	2.4GHz 2400~2483.5MHz Band Edge @ 3m	
ANT	802.11g CH11 2462MHz	
1	Horizontal	Fundamental
Peak	 <p>Date: 2016-08-20</p> <p>Level (dBuV/m)</p> <p>Frequency (MHz)</p> <p>PEAK_BE_74</p> <p>Site : 03CH12-HY Condition : PEAK_BE_74 3m HORN_9120D_1328 HORIZONTAL Detector : Peak Project : 672509 Mode : 12 Setting : 19</p>	 <p>Date: 2016-08-20</p> <p>Level (dBuV/m)</p> <p>Frequency (MHz)</p> <p>PEAK_74</p> <p>Site : 03CH12-HY Condition : PEAK_74 3m HORN_9120D_1328 HORIZONTAL Detector : Peak Project : 672509 Mode : 12 Setting : 19</p>
Avg.	 <p>Date: 2016-08-20</p> <p>Level (dBuV/m)</p> <p>Frequency (MHz)</p> <p>AVG_BE_54</p> <p>Site : 03CH12-HY Condition : AVG_BE_54 3m HORN_9120D_1328 HORIZONTAL Detector : Peak Project : 672509 Mode : 12 Setting : 19</p>	 <p>Date: 2016-08-20</p> <p>Level (dBuV/m)</p> <p>Frequency (MHz)</p> <p>AVG_54</p> <p>Site : 03CH12-HY Condition : AVG_54 3m HORN_9120D_1328 HORIZONTAL Detector : Peak Project : 672509 Mode : 12 Setting : 19</p>

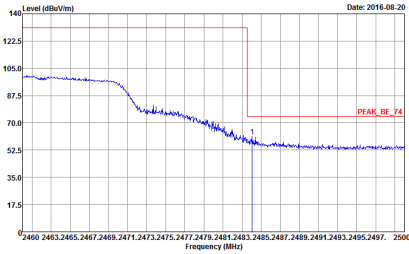
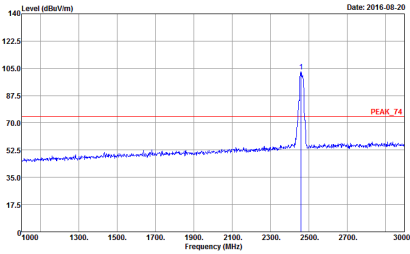
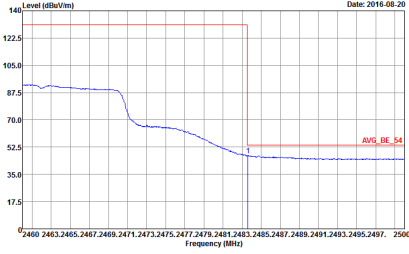
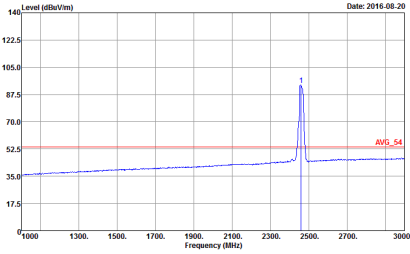

WIFI	2.4GHz 2400~2483.5MHz Band Edge @ 3m	
ANT	802.11g CH11 2462MHz	
1	Vertical	Fundamental
Peak	 <p>Site : 03CH12-HY Condition : PEAK_BE_74 3m HORN_9120D_1328 VERTICAL RBW:1000.000kHz VBW:3000.000kHz SWT:Auto Detector : Peak Project : 672509 Mode : 12 Setting : 19</p>	 <p>Site : 03CH12-HY Condition : PEAK_74 3m HORN_9120D_1328 VERTICAL RBW:1000.000kHz VBW:3000.000kHz SWT:Auto Detector : Peak Project : 672509 Mode : 12 Setting : 19</p>
Avg.	 <p>Site : 03CH12-HY Condition : AVG_BE_54 3m HORN_9120D_1328 VERTICAL RBW:1000.000kHz VBW:3.000kHz SWT:Auto Detector : Peak Project : 672509 Mode : 12 Setting : 19</p>	 <p>Site : 03CH12-HY Condition : AVG_54 3m HORN_9120D_1328 VERTICAL RBW:1000.000kHz VBW:3.000kHz SWT:Auto Detector : Peak Project : 672509 Mode : 12 Setting : 19</p>



2.4GHz 2400~2483.5MHz

WIFI 802.11n HT20 (Band Edge @ 3m)

WIFI	2.4GHz 2400~2483.5MHz Band Edge @ 3m	
ANT	802.11n HT20 CH01 2412MHz	
1	Horizontal	Fundamental
Peak	<p>Site : 03CH12-HY Condition : PEAK_BE_74 3m HORN_9120D_1328 HORIZONTAL : RBW:1000.000KHz VBW:3000.000KHz SWT:Auto : Peak Detector : Peak Project : 672509 Mode : 13 Setting : 19</p>	<p>Site : 03CH12-HY Condition : PEAK_74 3m HORN_9120D_1328 HORIZONTAL : RBW:1000.000KHz VBW:3000.000KHz SWT:Auto Detector : Peak Project : 672509 Mode : 13 Setting : 19</p>
Avg.	<p>Site : 03CH12-HY Condition : AVG_BE_54 3m HORN_9120D_1328 HORIZONTAL : RBW:1000.000KHz VBW:1.000KHz SWT:Auto Detector : Peak Project : 672509 Mode : 13 Setting : 19</p>	<p>Site : 03CH12-HY Condition : AVG_54 3m HORN_9120D_1328 HORIZONTAL : RBW:1000.000KHz VBW:1.000KHz SWT:Auto Detector : Peak Project : 672509 Mode : 13 Setting : 19</p>

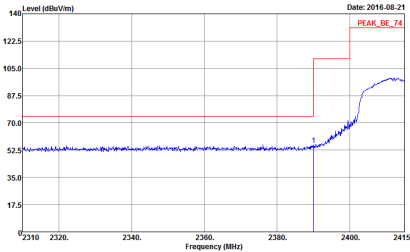
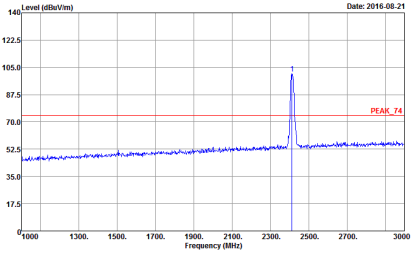
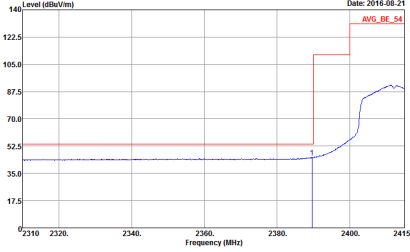
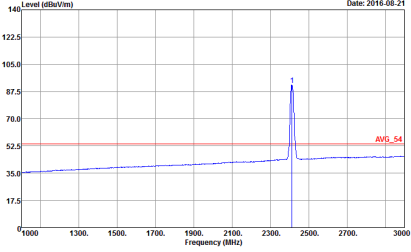

WIFI	2.4GHz 2400~2483.5MHz Band Edge @ 3m	
ANT	802.11n HT20 CH01 2412MHz	
1	Vertical	Fundamental
Peak	 <p>Date: 2016-08-21</p> <p>Site : 03CH12-HY Condition : PEAK_BE_74 3m HORN_9120D_1328 VERTICAL RBW:1000.000KHz VBW:3000.000KHz SWT:Auto Detector : Peak Project : 672509 Mode : 13 Setting : 19</p>	 <p>Date: 2016-08-21</p> <p>Site : 03CH12-HY Condition : PEAK_74 3m HORN_9120D_1328 VERTICAL RBW:1000.000KHz VBW:3000.000KHz SWT:Auto Detector : Peak Project : 672509 Mode : 13 Setting : 19</p>
Avg.	 <p>Date: 2016-08-21</p> <p>Site : 03CH12-HY Condition : AVG_BE_54 3m HORN_9120D_1328 VERTICAL RBW:1000.000KHz VBW:1.000KHz SWT:Auto Detector : Peak Project : 672509 Mode : 13 Setting : 19</p>	 <p>Date: 2016-08-21</p> <p>Site : 03CH12-HY Condition : AVG_54 3m HORN_9120D_1328 VERTICAL RBW:1000.000KHz VBW:1.000KHz SWT:Auto Detector : Peak Project : 672509 Mode : 13 Setting : 19</p>

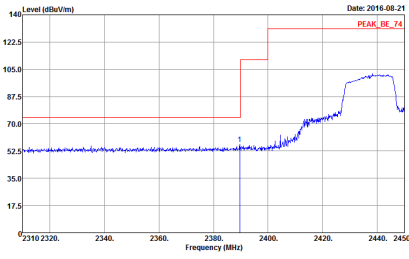
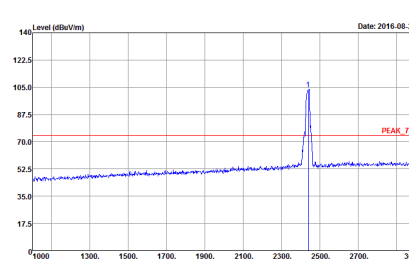
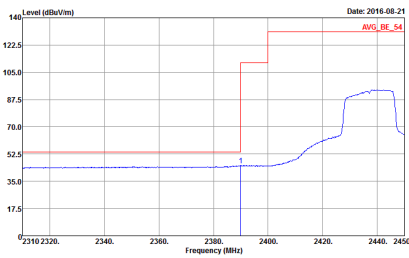
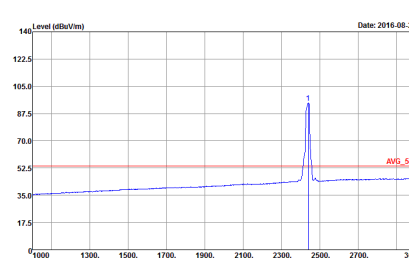

WIFI	2.4GHz 2400~2483.5MHz Band Edge @ 3m	
ANT	802.11n HT20 CH06 2437MHz - L	
1	Horizontal	Fundamental
Peak	 <p>Site Condition : 03CH12-HY : PEAK_BE_74 3m HORN_9120D_1338 HORIZONTAL : RBW:1000.000KHz VBW:3000.000KHz SWT:Auto Detector : Peak Project : 672509 Mode : 14 Setting : 19</p>	 <p>Site Condition : 03CH12-HY : PEAK_74 3m HORN_9120D_1338 HORIZONTAL : RBW:1000.000KHz VBW:3000.000KHz SWT:Auto Detector : Peak Project : 672509 Mode : 14 Setting : 19</p>
Avg.	 <p>Site Condition : 03CH12-HY : AVG_BE_54 3m HORN_9120D_1338 HORIZONTAL : RBW:1000.000KHz VBW:1.000KHz SWT:Auto Detector : Peak Project : 672509 Mode : 14 Setting : 19</p>	 <p>Site Condition : 03CH12-HY : AVG_54 3m HORN_9120D_1338 HORIZONTAL : RBW:1000.000KHz VBW:1.000KHz SWT:Auto Detector : Peak Project : 672509 Mode : 14 Setting : 19</p>

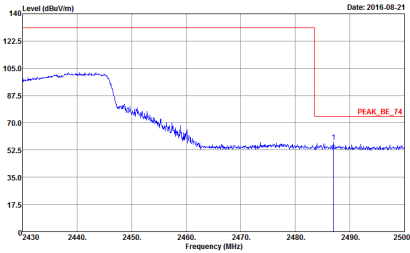
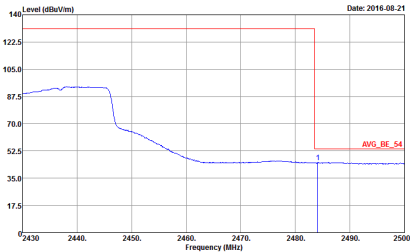

WIFI	2.4GHz 2400~2483.5MHz Band Edge @ 3m	
ANT	802.11n HT20 CH06 2437MHz - R	
1	Horizontal	Fundamental
Peak	 <p>Date: 2016.08.21</p> <p>Site : 03CH12-HY Condition : PEAK_BE_74 3m HORN_9120D_1328 HORIZONTAL Detector : Peak Project : 672509 Mode : 14 Setting : 19</p>	Left blank
Avg.	 <p>Date: 2016.08.21</p> <p>Site : 03CH12-HY Condition : AVG_BE_54 3m HORN_9120D_1328 HORIZONTAL Detector : Peak Project : 672509 Mode : 14 Setting : 19</p>	Left blank

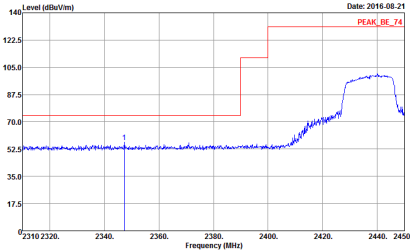
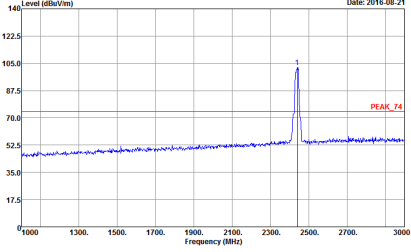
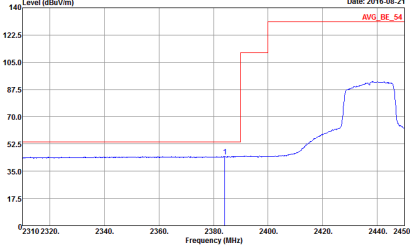
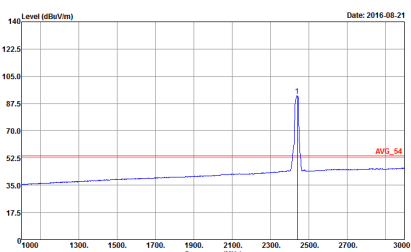

WIFI	2.4GHz 2400~2483.5MHz Band Edge @ 3m	
ANT	802.11n HT20 CH06 2437MHz - L	
1	Vertical	Fundamental
Peak	 <p>Date: 2016-08-21</p> <p>Level (dBuV/m)</p> <p>Frequency (MHz)</p> <p>PEAK_BE_74</p> <p>Site : 03CH12-HY Condition : PEAK_BE_74 3m HORN_9120D_1328 VERTICAL Detector : Peak Project : 672509 Mode : 14 Setting : 19</p>	 <p>Date: 2016-08-21</p> <p>Level (dBuV/m)</p> <p>Frequency (MHz)</p> <p>PEAK_74</p> <p>Site : 03CH12-HY Condition : PEAK_74 3m HORN_9120D_1328 VERTICAL Detector : Peak Project : 672509 Mode : 14 Setting : 19</p>
Avg.	 <p>Date: 2016-08-21</p> <p>Level (dBuV/m)</p> <p>Frequency (MHz)</p> <p>AVG_BE_54</p> <p>Site : 03CH12-HY Condition : AVG_BE_54 3m HORN_9120D_1328 VERTICAL Detector : Peak Project : 672509 Mode : 14 Setting : 19</p>	 <p>Date: 2016-08-21</p> <p>Level (dBuV/m)</p> <p>Frequency (MHz)</p> <p>AVG_54</p> <p>Site : 03CH12-HY Condition : AVG_54 3m HORN_9120D_1328 VERTICAL Detector : Peak Project : 672509 Mode : 14 Setting : 19</p>



WIFI	2.4GHz 2400~2483.5MHz Band Edge @ 3m	
ANT	802.11n HT20 CH06 2437MHz - R	
1	Vertical	Fundamental
Peak	<p>Site : 03CH12-HY Condition : PEAK_BE_74 3m HORN_9120D_1328 VERTICAL RBW:1000.000KHz VBW:3000.000KHz SWT:Auto Detector : Peak Project : 672509 Mode : 14 Setting : 19</p>	Left Blank
Avg.	<p>Site : 03CH12-HY Condition : AVG_BE_54 3m HORN_9120D_1328 VERTICAL RBW:1000.000KHz VBW:1.000KHz SWT:Auto Detector : Peak Project : 672509 Mode : 14 Setting : 19</p>	Left Blank

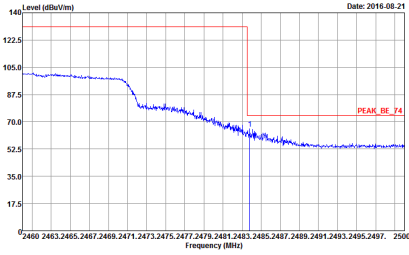
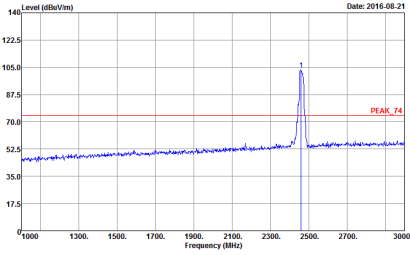
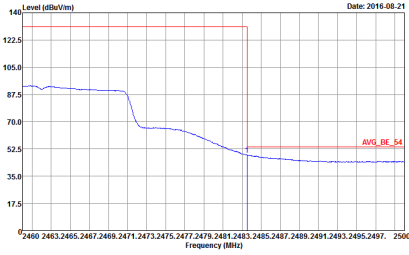
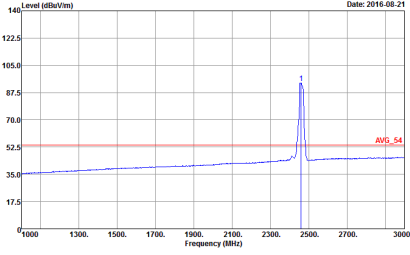

WIFI	2.4GHz 2400~2483.5MHz Band Edge @ 3m	
ANT	802.11n HT20 CH11 2462MHz	
1	<p style="text-align: center;">Horizontal</p>  <p>Site : 03CH12-HY Condition : PEAK_BE_74 3m HORN_9120D_1328 HORIZONTAL Detector : Peak Project : 672509 Mode : 15 Setting : 19</p>	<p style="text-align: center;">Fundamental</p>  <p>Site : 03CH12-HY Condition : PEAK_74 3m HORN_9120D_1328 HORIZONTAL Detector : Peak Project : 672509 Mode : 15 Setting : 19</p>
Peak	 <p>Site : 03CH12-HY Condition : AVG_BE_54 3m HORN_9120D_1328 HORIZONTAL Detector : Peak Project : 672509 Mode : 15 Setting : 19</p>	 <p>Site : 03CH12-HY Condition : AVG_54 3m HORN_9120D_1328 HORIZONTAL Detector : Peak Project : 672509 Mode : 15 Setting : 19</p>
Avg.		

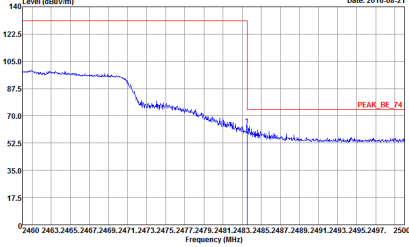
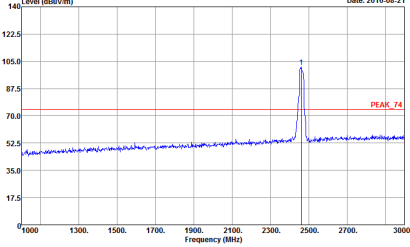
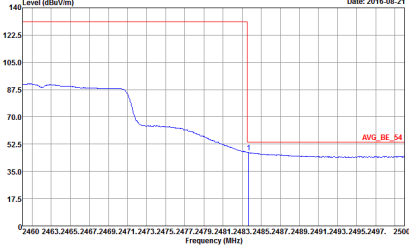
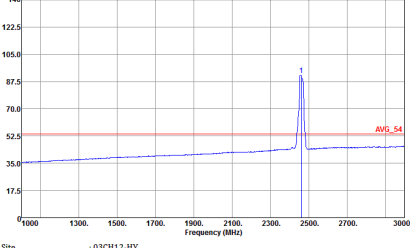

WIFI	2.4GHz 2400~2483.5MHz Fundamental @ 3m	
ANT	802.11n HT20 CH11 2462MHz	
1	<p style="text-align: center;">Vertical</p>  <p>Peak</p> <pre> Site : 03CH12-HY Condition : PEAK_BE_74 3m HORN_9120D_1328 VERTICAL : RBW:1000.000kHz VBW:3000.000kHz SWT:Auto Detector : Peak Project : 672509 Mode : 15 Setting : 19 </pre>	<p style="text-align: center;">Fundamental</p>  <pre> Site : 03CH12-HY Condition : PEAK_74 3m HORN_9120D_1328 VERTICAL : RBW:1000.000kHz VBW:3000.000kHz SWT:Auto Detector : Peak Project : 672509 Mode : 15 Setting : 19 </pre>
Avg.	 <pre> Site : 03CH12-HY Condition : AVG_BE_54 3m HORN_9120D_1328 VERTICAL : RBW:1000.000kHz VBW:1.000kHz SWT:Auto Detector : Peak Project : 672509 Mode : 15 Setting : 19 </pre>	 <pre> Site : 03CH12-HY Condition : AVG_54 3m HORN_9120D_1328 VERTICAL : RBW:1000.000kHz VBW:1.000kHz SWT:Auto Detector : Peak Project : 672509 Mode : 15 Setting : 19 </pre>



2.4GHz 2400~2483.5MHz

WIFI 802.11n HT40 (Band Edge @ 3m)

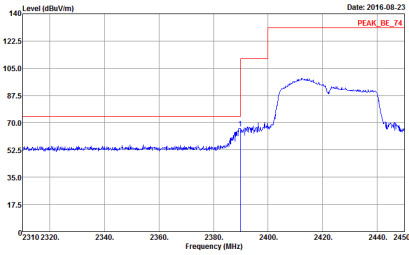
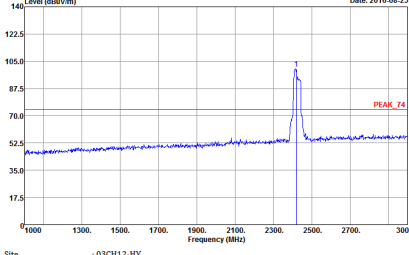
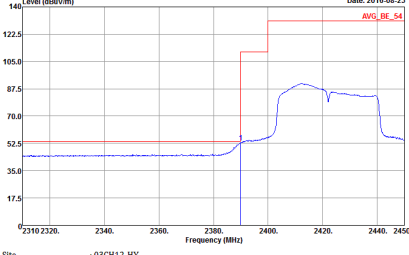
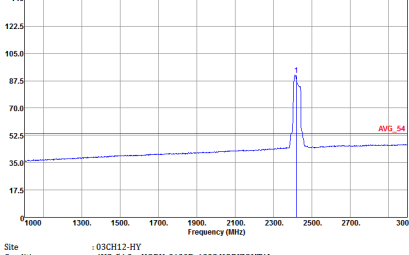
WIFI	2.4GHz 2400~2483.5MHz Band Edge @ 3m	
ANT	802.11n HT40 CH03 2422MHz - L	
1	Horizontal	Fundamental
Peak	 <p>Level (dBuV/m) vs Frequency (MHz) plot showing a peak at approximately 2422 MHz. The y-axis ranges from 17.5 to 140 dBuV/m, and the x-axis ranges from 2310 to 2450 MHz. A red horizontal line indicates the peak level at approximately 135 dBuV/m, labeled 'PEAK_BE_74'.</p> <p>Site : 03CH12-HY Condition : PEAK_BE_74 3m HORN_9120D_1328 HORIZONTAL Detector : Peak Project : 672509 Mode : 16 Setting : 17</p>	 <p>Level (dBuV/m) vs Frequency (MHz) plot showing a sharp peak at approximately 2422 MHz. The y-axis ranges from 17.5 to 140 dBuV/m, and the x-axis ranges from 1900 to 3000 MHz. A red horizontal line indicates the peak level at approximately 70 dBuV/m, labeled 'PEAK_74'.</p> <p>Site : 03CH12-HY Condition : PEAK_74 3m HORN_9120D_1328 HORIZONTAL Detector : Peak Project : 672509 Mode : 16 Setting : 17</p>
Avg.	 <p>Level (dBuV/m) vs Frequency (MHz) plot showing the average spectrum. The y-axis ranges from 17.5 to 140 dBuV/m, and the x-axis ranges from 2310 to 2450 MHz. A red horizontal line indicates the average level at approximately 135 dBuV/m, labeled 'AVG_BE_54'.</p> <p>Site : 03CH12-HY Condition : AVG_BE_54 3m HORN_9120D_1328 HORIZONTAL Detector : Peak Project : 672509 Mode : 16 Setting : 17</p>	 <p>Level (dBuV/m) vs Frequency (MHz) plot showing the average spectrum. The y-axis ranges from 17.5 to 140 dBuV/m, and the x-axis ranges from 1900 to 3000 MHz. A red horizontal line indicates the average level at approximately 55 dBuV/m, labeled 'AVG_54'.</p> <p>Site : 03CH12-HY Condition : AVG_54 3m HORN_9120D_1328 HORIZONTAL Detector : Peak Project : 672509 Mode : 16 Setting : 17</p>



WIFI	2.4GHz 2400~2483.5MHz Band Edge @ 3m	
ANT	802.11n HT40 CH03 2422MHz - R	
1	Horizontal	Fundamental
Peak	<p>Site : -03CH12-HY Condition : -PEAK_BE_74 3m HORN_9120D_1328 HORIZONTAL RBW:1000.000KHz VBW:3000.000KHz SWT:Auto Detector : -Peak Project : -672509 Mode : -16 Setting : -17</p>	Left Blank
Avg.	<p>Site : -03CH12-HY Condition : -AVG_BE_54 3m HORN_9120D_1328 HORIZONTAL RBW:1000.000KHz VBW:3.000KHz SWT:Auto Detector : -Peak Project : -672509 Mode : -16 Setting : -17</p>	Left Blank

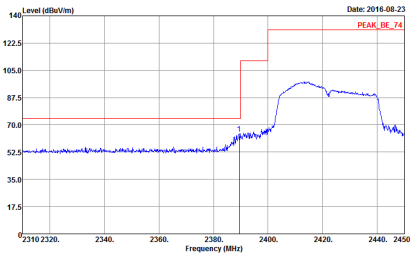
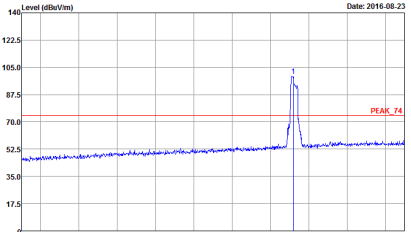
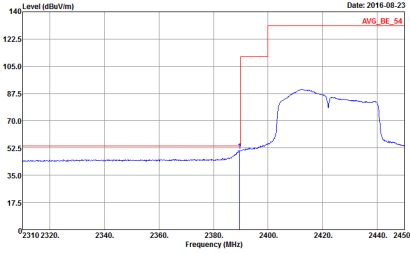
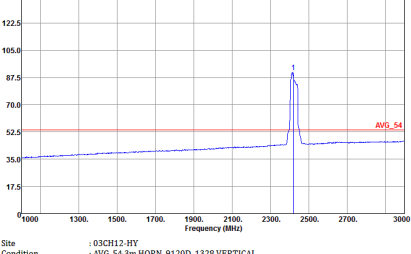

WIFI	2.4GHz 2400~2483.5MHz Band Edge @ 3m	
ANT	802.11n HT40 CH03 2422MHz - L	
1	Vertical	Fundamental
Peak	 <p>Date: 2016-08-23 PEAK_BE_74</p> <p>Site : 03CH12-HY Condition : PEAK_BE_74 3m HORN_9120D_1328 VERTICAL Detector : Peak Project : 672509 Mode : 16 Setting : 17</p>	 <p>Date: 2016-08-23 PEAK_74</p> <p>Site : 03CH12-HY Condition : PEAK_74 3m HORN_9120D_1328 VERTICAL Detector : Peak Project : 672509 Mode : 16 Setting : 17</p>
Avg.	 <p>Date: 2016-08-23 AVG_BE_54</p> <p>Site : 03CH12-HY Condition : AVG_BE_54 3m HORN_9120D_1328 VERTICAL Detector : Peak Project : 672509 Mode : 16 Setting : 17</p>	 <p>Date: 2016-08-23 AVG_54</p> <p>Site : 03CH12-HY Condition : AVG_54 3m HORN_9120D_1328 VERTICAL Detector : Peak Project : 672509 Mode : 16 Setting : 17</p>



WIFI	2.4GHz 2400~2483.5MHz Band Edge @ 3m	
ANT	802.11n HT40 CH03 2422MHz - R	
1	Vertical	Fundamental
Peak	<p>Site : 03CH12-HY Condition : PEAK_BE_74 3m HORN_9120D_1328 VERTICAL : RBW:1000.000KHz VBW:3000.000KHz SWT:Auto Detector : Peak Project : 672509 Mode : 16 Setting : 17</p>	Left blank
Avg.	<p>Site : 03CH12-HY Condition : AVG_BE_54 3m HORN_9120D_1328 VERTICAL : RBW:1000.000KHz VBW:3.000KHz SWT:Auto Detector : Peak Project : 672509 Mode : 16 Setting : 17</p>	Left blank

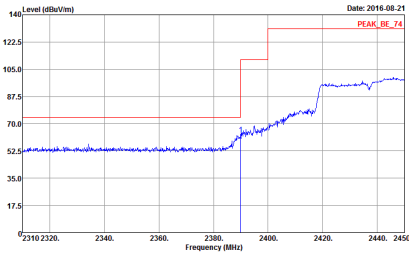
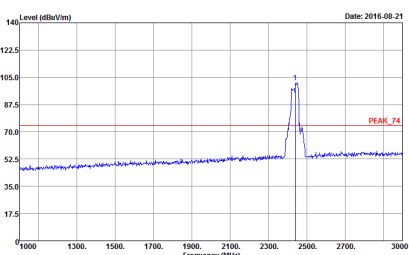
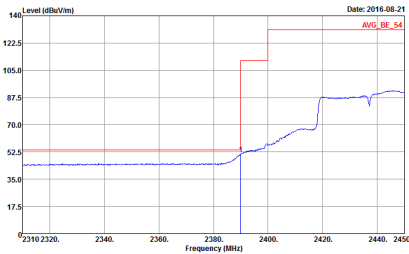
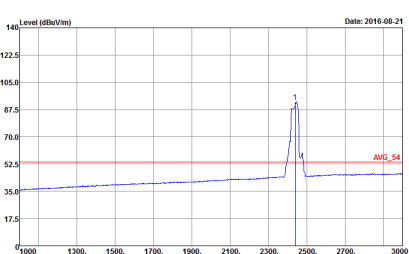

WIFI	2.4GHz 2400~2483.5MHz Band Edge @ 3m	
ANT	802.11n HT40 CH06 2437MHz - L	
1	<p style="text-align: center;">Horizontal</p>  <p style="text-align: right;">Date: 2016-08-21 PEAK_BE_74</p> <p>Site : 03CH12-HY Condition : PEAK_BE_74 3m HORN_9120D_1328 HORIZONTAL Detector : Peak Project : 672509 Mode : 17 Setting : 18.5</p>	<p style="text-align: center;">Fundamental</p>  <p style="text-align: right;">Date: 2016-08-21 PEAK_74</p> <p>Site : 03CH12-HY Condition : PEAK_74 3m HORN_9120D_1328 HORIZONTAL Detector : Peak Project : 672509 Mode : 17 Setting : 18.5</p>
Avg.	 <p style="text-align: right;">Date: 2016-08-21 AVG_BE_54</p> <p>Site : 03CH12-HY Condition : AVG_BE_54 3m HORN_9120D_1328 HORIZONTAL Detector : Peak Project : 672509 Mode : 17 Setting : 18.5</p>	 <p style="text-align: right;">Date: 2016-08-21 AVG_54</p> <p>Site : 03CH12-HY Condition : AVG_54 3m HORN_9120D_1328 HORIZONTAL Detector : Peak Project : 672509 Mode : 17 Setting : 18.5</p>

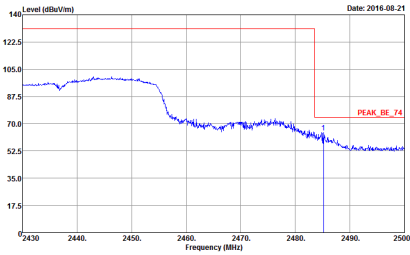
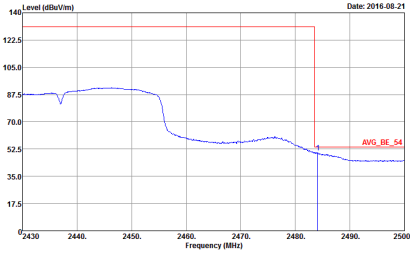

WIFI	2.4GHz 2400~2483.5MHz Band Edge @ 3m	
ANT	802.11n HT40 CH06 2437MHz - R	
1	Horizontal	Fundamental
Peak	 <p> Site : 03CH12-HY Condition : PEAK_BE_74 3m HORN_9120D_1328 HORIZONTAL RBW:1000.000KHz VBW:3000.000KHz SWT:Auto Detector : Peak Project : 672509 Mode : 17 Setting : 18.5 </p>	Left blank
Avg.	 <p> Site : 03CH12-HY Condition : AVG_BE_54 3m HORN_9120D_1328 HORIZONTAL RBW:1000.000KHz VBW:3000.000KHz SWT:Auto Detector : Peak Project : 672509 Mode : 17 Setting : 18.5 </p>	Left blank

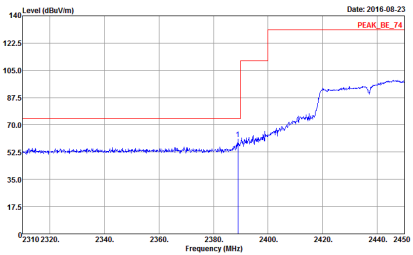
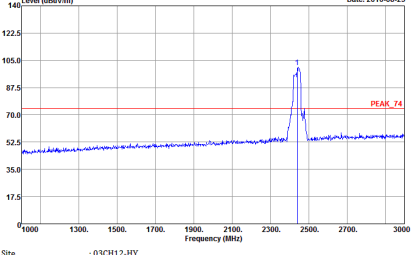
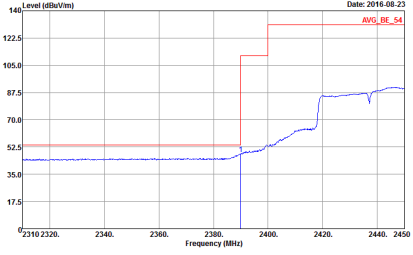
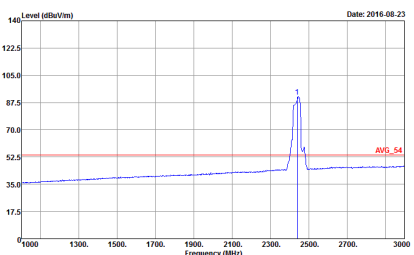

WIFI	2.4GHz 2400~2483.5MHz Band Edge @ 3m	
ANT	802.11n HT40 CH06 2437MHz - L	
1	Vertical	Fundamental
Peak	 <p>Date: 2016-08-23 PEAK_BE_74</p> <p>Site : 03CH12-HY Condition : PEAK_BE_74 3m HORN_9120D_1328 VERTICAL Detector : Peak Project : 672509 Mode : 17 Setting : 18.5</p>	 <p>Date: 2016-08-23 PEAK_74</p> <p>Site : 03CH12-HY Condition : PEAK_74 3m HORN_9120D_1328 VERTICAL Detector : Peak Project : 672509 Mode : 17 Setting : 18.5</p>
Avg.	 <p>Date: 2016-08-23 AVG_BE_54</p> <p>Site : 03CH12-HY Condition : AVG_BE_54 3m HORN_9120D_1328 VERTICAL Detector : Peak Project : 672509 Mode : 17 Setting : 18.5</p>	 <p>Date: 2016-08-23 AVG_54</p> <p>Site : 03CH12-HY Condition : AVG_54 3m HORN_9120D_1328 VERTICAL Detector : Peak Project : 672509 Mode : 17 Setting : 18.5</p>

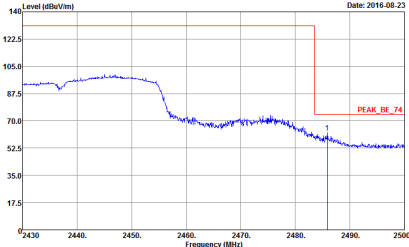
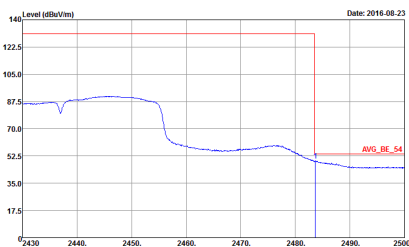

WIFI	2.4GHz 2400~2483.5MHz Band Edge @ 3m	
ANT	802.11n HT40 CH06 2437MHz - R	
1	Horizontal	Fundamental
Peak	 <p>Site : 03CH12-HY Condition : PEAK_BE_74 3m HORN_9120D_1328 VERTICAL RBW:1000.000KHz VBW:3000.000KHz SWT:Auto Detector : Peak Project : 672509 Mode : 17 Setting : 18.5</p>	Left blank
Avg.	 <p>Site : 03CH12-HY Condition : AVG_BE_54 3m HORN_9120D_1328 VERTICAL RBW:1000.000KHz VBW:3.000KHz SWT:Auto Detector : Peak Project : 672509 Mode : 17 Setting : 18.5</p>	Left blank

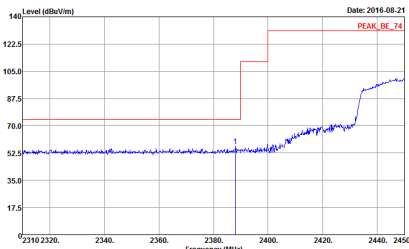
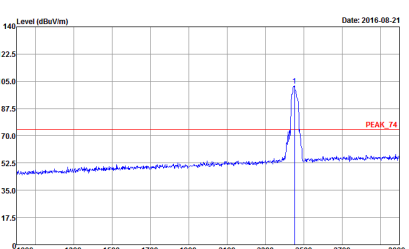
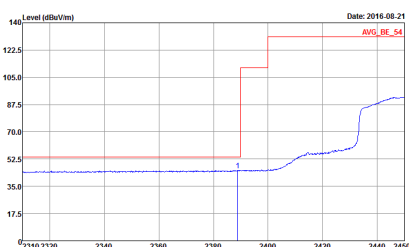
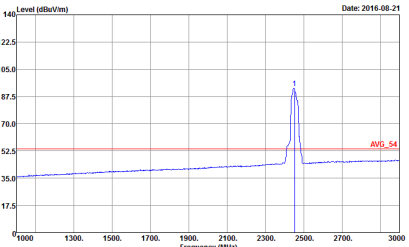

WIFI	2.4GHz 2400~2483.5MHz Band Edge @ 3m	
ANT	802.11n HT40 CH09 2452MHz - L	
1	Horizontal	Fundamental
Peak	 <p>Level (dBuV/m) vs Frequency (MHz) plot showing a peak at 2452 MHz. The y-axis ranges from 17.5 to 140 dBuV/m, and the x-axis ranges from 2310 to 2450 MHz. A red horizontal line indicates the peak level at approximately 135 dBuV/m.</p> <p>Site : 03CH12-HY Condition : PEAK_BE_74 3m HORN_9120D_1328 HORIZONTAL Detector : Peak Project : 672509 Mode : 18 Setting : 18.5</p>	 <p>Level (dBuV/m) vs Frequency (MHz) plot showing a peak at 2452 MHz. The y-axis ranges from 17.5 to 140 dBuV/m, and the x-axis ranges from 1000 to 3000 MHz. A red horizontal line indicates the peak level at approximately 75 dBuV/m.</p> <p>Site : 03CH12-HY Condition : PEAK_74 3m HORN_9120D_1328 HORIZONTAL Detector : Peak Project : 672509 Mode : 18 Setting : 18.5</p>
Avg.	 <p>Level (dBuV/m) vs Frequency (MHz) plot showing the average level. The y-axis ranges from 17.5 to 140 dBuV/m, and the x-axis ranges from 2310 to 2450 MHz. A red horizontal line indicates the average level at approximately 55 dBuV/m.</p> <p>Site : 03CH12-HY Condition : AVG_BE_54 3m HORN_9120D_1328 HORIZONTAL Detector : Peak Project : 672509 Mode : 18 Setting : 18.5</p>	 <p>Level (dBuV/m) vs Frequency (MHz) plot showing the average level. The y-axis ranges from 17.5 to 140 dBuV/m, and the x-axis ranges from 1000 to 3000 MHz. A red horizontal line indicates the average level at approximately 55 dBuV/m.</p> <p>Site : 03CH12-HY Condition : AVG_54 3m HORN_9120D_1328 HORIZONTAL Detector : Peak Project : 672509 Mode : 18 Setting : 18.5</p>

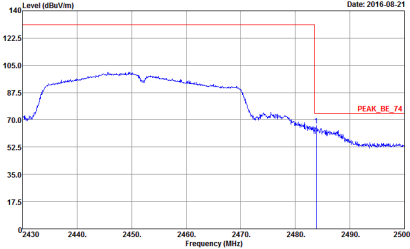
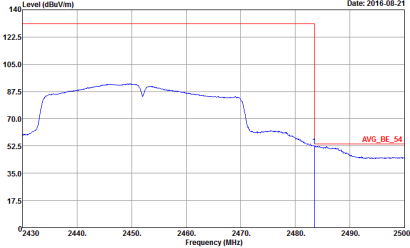

WIFI	2.4GHz 2400~2483.5MHz Band Edge @ 3m	
ANT	802.11n HT40 CH09 2452MHz - R	
1	Horizontal	Fundamental
Peak	 <p>Date: 2016.08.21</p> <p>Site : 03CH12-HY Condition : PEAK_BE_74 3m HORN_9120D_1338 HORIZONTAL Detector : Peak Project : 672509 Mode : 1B Setting : 18.5</p>	Left blank
Avg.	 <p>Date: 2016.08.21</p> <p>Site : 03CH12-HY Condition : AVG_BE_54 3m HORN_9120D_1338 HORIZONTAL Detector : Peak Project : 672509 Mode : 1B Setting : 18.5</p>	Left blank

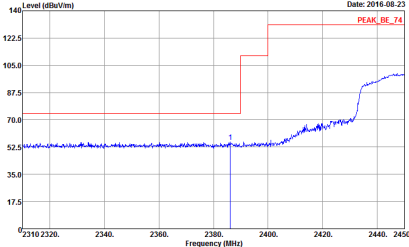
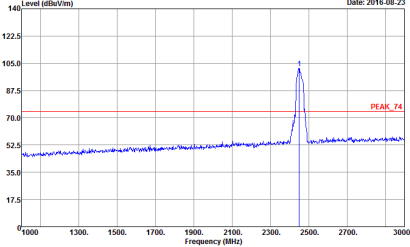
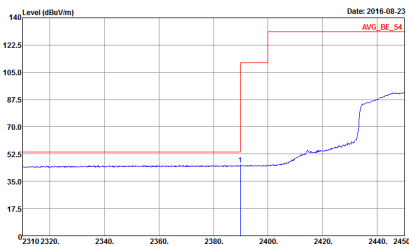
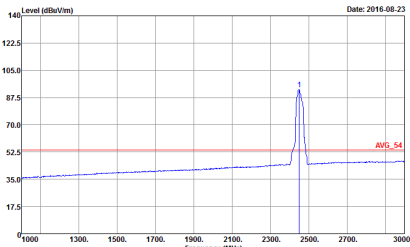

WIFI	2.4GHz 2400~2483.5MHz Band Edge @ 3m	
ANT	802.11n HT40 CH09 2452MHz - L	
1	Vertical	Fundamental
Peak	 <p>Date: 2016-08-23</p> <p>Level (dBuV/m)</p> <p>Frequency (MHz)</p> <p>PEAK_BE_74</p> <p>Site : 03CH12-HY Condition : PEAK_BE_74 3m HORN_9120D_1328 VERTICAL RBW:1000.000KHz VBW:3000.000KHz SWT:Auto Detector : Peak Project : 672509 Mode : 18 Setting : 18.5</p>	 <p>Date: 2016-08-23</p> <p>Level (dBuV/m)</p> <p>Frequency (MHz)</p> <p>PEAK_14</p> <p>Site : 03CH12-HY Condition : PEAK_74 3m HORN_9120D_1328 VERTICAL RBW:1000.000KHz VBW:3000.000KHz SWT:Auto Detector : Peak Project : 672509 Mode : 18 Setting : 18.5</p>
Avg.	 <p>Date: 2016-08-23</p> <p>Level (dBuV/m)</p> <p>Frequency (MHz)</p> <p>AVG_BE_54</p> <p>Site : 03CH12-HY Condition : AVG_BE_54 3m HORN_9120D_1328 VERTICAL RBW:1000.000KHz VBW:3.000KHz SWT:Auto Detector : Peak Project : 672509 Mode : 18 Setting : 18.5</p>	 <p>Date: 2016-08-23</p> <p>Level (dBuV/m)</p> <p>Frequency (MHz)</p> <p>AVG_54</p> <p>Site : 03CH12-HY Condition : AVG_54 3m HORN_9120D_1328 VERTICAL RBW:1000.000KHz VBW:3.000KHz SWT:Auto Detector : Peak Project : 672509 Mode : 18 Setting : 18.5</p>

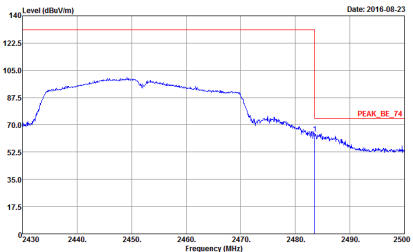
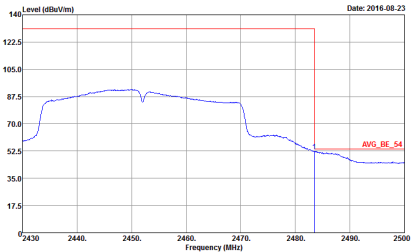

WIFI	2.4GHz 2400~2483.5MHz Band Edge @ 3m	
ANT	802.11n HT40 CH09 2452MHz - R	
1	Vertical	Fundamental
Peak	 <p>Date: 2016.08.23</p> <p>Site : 03CH12-HY Condition : PEAK_BE_74 3m HORN_9120D_1328 VERTICAL RBW:1000.000KHz VBW:3000.000KHz SWT:Auto Detector : Peak Project : 672509 Mode : 1B Setting : 18.5</p>	Left blank
Avg.	 <p>Date: 2016.08.23</p> <p>Site : 03CH12-HY Condition : AVG_BE_54 3m HORN_9120D_1328 VERTICAL RBW:1000.000KHz VBW:3.000KHz SWT:Auto Detector : Peak Project : 672509 Mode : 1B Setting : 18.5</p>	Left blank



2.4GHz 2400~2483.5MHz
WIFI 802.11b (Harmonic @ 3m)

Table with 2 columns: WIFI (2.4GHz 2400~2483.5MHz Harmonic @ 3m), ANT (802.11b CH01 2412MHz). Row 1: 1. Sub-headers: Horizontal, Vertical. Content: Two graphs showing Level (dBuV/m) vs Frequency (MHz) for Horizontal and Vertical orientations. Includes metadata like Date: 2016-08-23, Site: 03CH12-HY, Condition: PEAK_74 3m HORN_9120D_1328 HORIZONTAL, etc.

Peak
Avg.

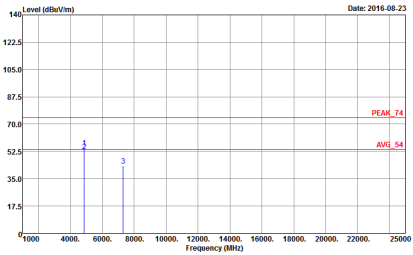
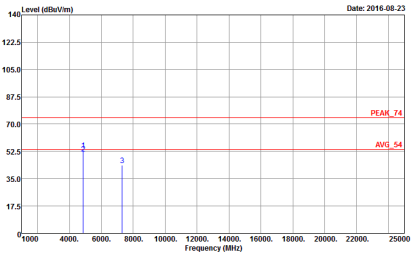

WIFI	2.4GHz 2400~2483.5MHz Harmonic @ 3m	
ANT	802.11b CH06 2437MHz	
1	Horizontal	Vertical
Peak Avg.	 <p>Site : 03CH12-HY Condition : PEAK_74 3m HORN_9120D_132B HORIZONTAL Detector : Peak Project : 672509 Mode : S Setting : 20</p>	 <p>Site : 03CH12-HY Condition : PEAK_74 3m HORN_9120D_132B VERTICAL Detector : Peak Project : 672509 Mode : S Setting : 20</p>

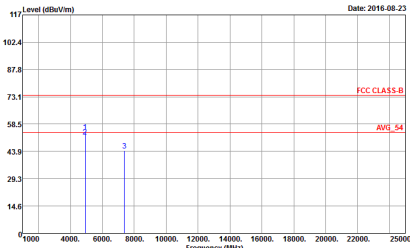
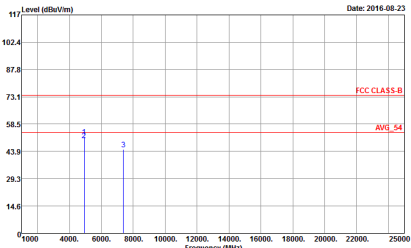

WIFI	2.4GHz 2400~2483.5MHz Harmonic @ 3m	
ANT	802.11b CH11 2462MHz	
1	Horizontal	Vertical
Peak Avg.	 <p>Site : 03CH12-HY Condition : FCC CLASS-B 3m HORN_9120D_1328 HORIZONTAL Detector : Peak Project : 672509 Mode : 9 Setting : 20</p>	 <p>Site : 03CH12-HY Condition : FCC CLASS-B 3m HORN_9120D_1328 VERTICAL Detector : Peak Project : 672509 Mode : 9 Setting : 20</p>



2.4GHz 2400~2483.5MHz

WIFI 802.11g (Harmonic @ 3m)

WIFI	2.4GHz 2400~2483.5MHz Harmonic @ 3m	
ANT	802.11g CH01 2412MHz	
1	Horizontal	Vertical
Peak Avg.	<p>Site : 03CH12-HY Condition : FCC CLASS-B 3m HORN_9120D_1328 HORIZONTAL Detector : Peak Project : 672509 Mode : 10</p>	<p>Site : 03CH12-HY Condition : FCC CLASS-B 3m HORN_9120D_1328 VERTICAL Detector : Peak Project : 672509 Mode : 10</p>

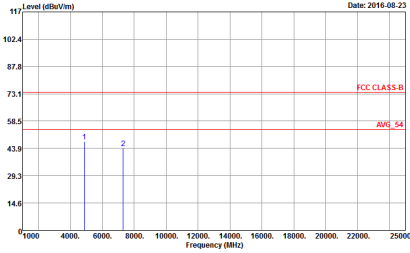
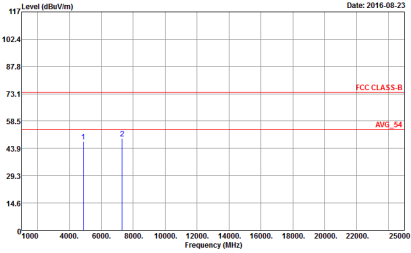

WIFI	2.4GHz 2400~2483.5MHz Harmonic @ 3m	
ANT	802.11g CH06 2437MHz	
1	Horizontal	Vertical
<p>Peak</p> <p>Avg.</p>	 <p>Site : 03CH12-HY Condition : FCC CLASS-B 3m HORN_9120D_1328 HORIZONTAL Detector : Peak Project : 672509 Mode : 11</p>	 <p>Site : 03CH12-HY Condition : FCC CLASS-B 3m HORN_9120D_1328 VERTICAL Detector : Peak Project : 672509 Mode : 11</p>

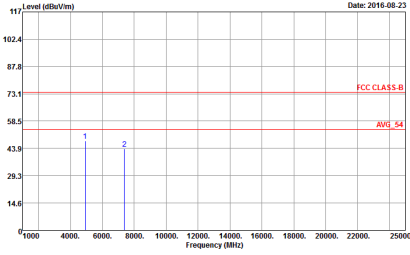
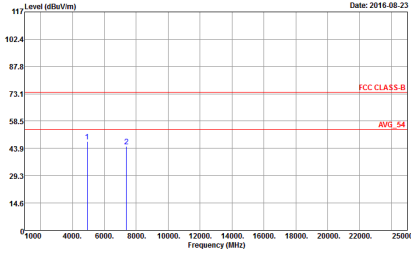

WIFI	2.4GHz 2400~2483.5MHz Harmonic @ 3m	
ANT	802.11g CH11 2462MHz	
1	Horizontal	Vertical
<p>Peak</p> <p>Avg.</p>	 <p>Site : 03CH12-HY Condition : FCC CLASS-B 3m HORN_9120D_1328 HORIZONTAL Detector : Peak Project : 672509 Mode : 12</p>	 <p>Site : 03CH12-HY Condition : FCC CLASS-B 3m HORN_9120D_1328 VERTICAL Detector : Peak Project : 672509 Mode : 12</p>



2.4GHz 2400~2483.5MHz

WIFI 802.11n HT20 (Harmonic @ 3m)

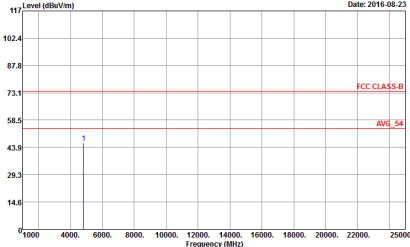
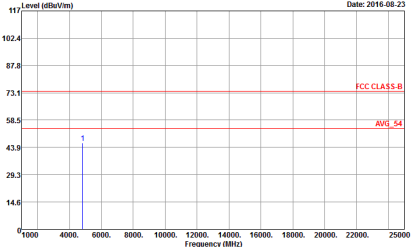
WIFI	2.4GHz 2400~2483.5MHz Harmonic @ 3m	
ANT	802.11n HT20 CH01 2412MHz	
1	Horizontal	Vertical
<p>Peak Avg.</p>	 <p>Site : 03CH12-HY Condition : FCC CLASS-B 3m HORN_9120D_1328 HORIZONTAL Detector : Peak Project : 672509 Mode : 13</p>	 <p>Site : 03CH12-HY Condition : FCC CLASS-B 3m HORN_9120D_1328 VERTICAL Detector : Peak Project : 672509 Mode : 13</p>

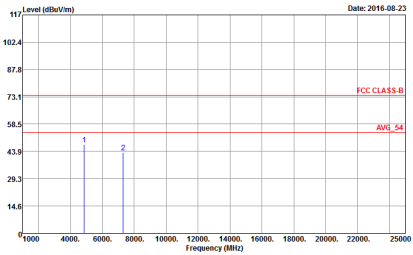
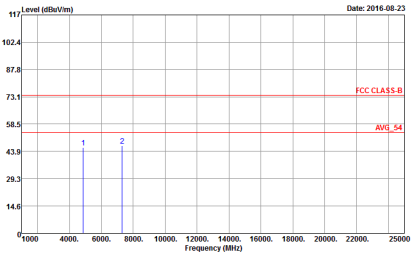

WIFI	2.4GHz 2400~2483.5MHz Harmonic @ 3m	
ANT	802.11n HT20 CH06 2437MHz	
1	Horizontal	Vertical
Peak Avg.	 <p>Site : 03CH12-HY Condition : FCC CLASS-B 3m HORN_9120D_1328 HORIZONTAL Detector : Peak Project : 672509 Mode : 14</p>	 <p>Site : 03CH12-HY Condition : FCC CLASS-B 3m HORN_9120D_1328 VERTICAL Detector : Peak Project : 672509 Mode : 14</p>

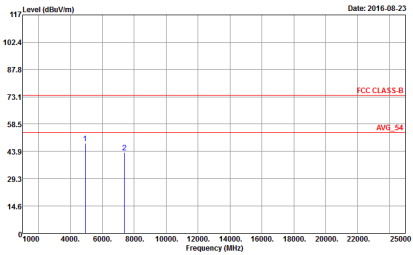
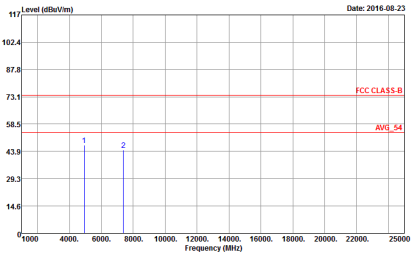

WIFI	2.4GHz 2400~2483.5MHz Harmonic @ 3m	
ANT	802.11n HT20 CH11 2462MHz	
1	Horizontal	Vertical
Peak Avg.	 <p>Site : 03CH12-HY Condition : FCC CLASS-B 3m HORN_9120D_1328 HORIZONTAL Detector : Peak Project : 672509 Mode : 15</p>	 <p>Site : 03CH12-HY Condition : FCC CLASS-B 3m HORN_9120D_1328 VERTICAL Detector : Peak Project : 672509 Mode : 15</p>



2.4GHz 2400~2483.5MHz

WIFI 802.11n HT40 (Harmonic @ 3m)

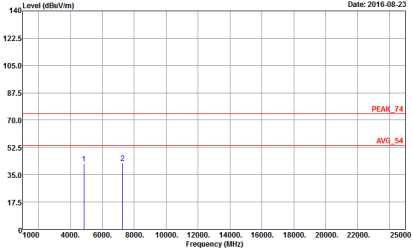
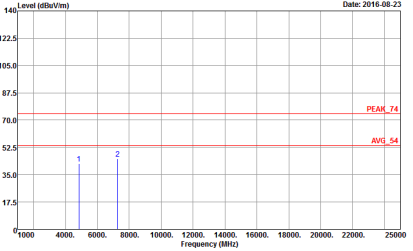
WIFI	2.4GHz 2400~2483.5MHz Harmonic @ 3m	
ANT	802.11n HT40 CH03 2422MHz	
1	Horizontal	Vertical
Peak Avg.	 <p>Site : 03CH12-HY Condition : PEAK_74 3m HORN_9120D_1328 HORIZONTAL Detector : Peak Project : 672509 Mode : 16 Setting : 18.5</p>	 <p>Site : 03CH12-HY Condition : PEAK_74 3m HORN_9120D_1328 VERTICAL Detector : Peak Project : 672509 Mode : 16 Setting : 18.5</p>



WIFI	2.4GHz 2400~2483.5MHz Harmonic @ 3m	
ANT	802.11n HT40 CH06 2437MHz	
1	Horizontal	Vertical
<p>Peak</p> <p>Avg.</p>	<p>Site : 03CH12-HY Condition : PEAK_T4 3m HORN_9120D_1328 HORIZONTAL Detector : Peak Project : 672509 Mode : 17 Setting : 18.5</p>	<p>Site : 03CH12-HY Condition : PEAK_T4 3m HORN_9120D_1328 VERTICAL Detector : Peak Project : 672509 Mode : 17 Setting : 18.5</p>

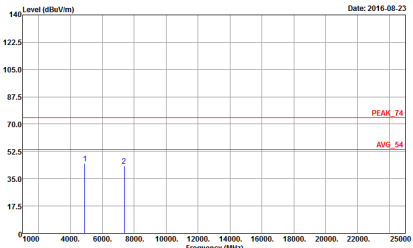
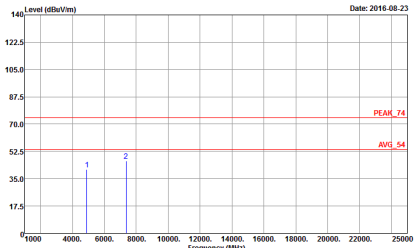

WIFI	2.4GHz 2400~2483.5MHz Harmonic @ 3m	
ANT	802.11n HT40 CH09 2452MHz	
1	Horizontal	Vertical
<p>Peak</p> <p>Avg.</p>	 <p>Site : 03CH12-HY Condition : PEAK_74 3m HORN_9120D_1328 HORIZONTAL Detector : Peak Project : 672509 Mode : 18 Setting : 18.5</p>	 <p>Site : 03CH12-HY Condition : PEAK_74 3m HORN_9120D_1328 VERTICAL Detector : Peak Project : 672509 Mode : 18 Setting : 18.5</p>

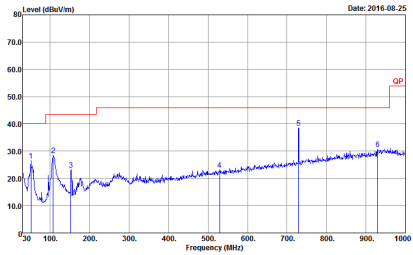
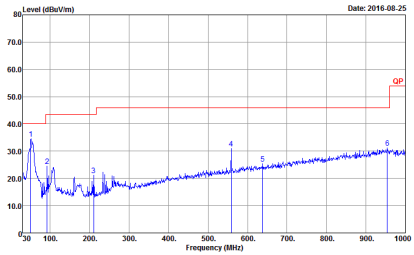

Emission below 1GHz
2.4GHz WIFI 802.11n HT40 (LF)

WIFI	2.4GHz 2400~2483.5MHz	
ANT	802.11n HT40 LF	
1	Horizontal	Vertical
<p>QP / Peak</p>	 <p>Site : 03CH12-HY Condition : QP 3m BILLOG_6111D_37059 HORIZONTAL Detector : Peak Project : 672509 Mode : 19</p>	 <p>Site : 03CH12-HY Condition : QP 3m BILLOG_6111D_37059 VERTICAL Detector : Peak Project : 672509 Mode : 19</p>



Appendix D. Duty Cycle Plots

Band	Duty Cycle(%)	T(us)	1/T(kHz)	VBW Setting
802.11b	100.00	-	-	10Hz
802.11g	94.62	704.00	1.42	3kHz
2.4GHz 802.11n HT20	97.17	1309.30	0.76	1kHz
2.4GHz 802.11n HT40	95.31	650.64	1.54	3kHz



802.11b

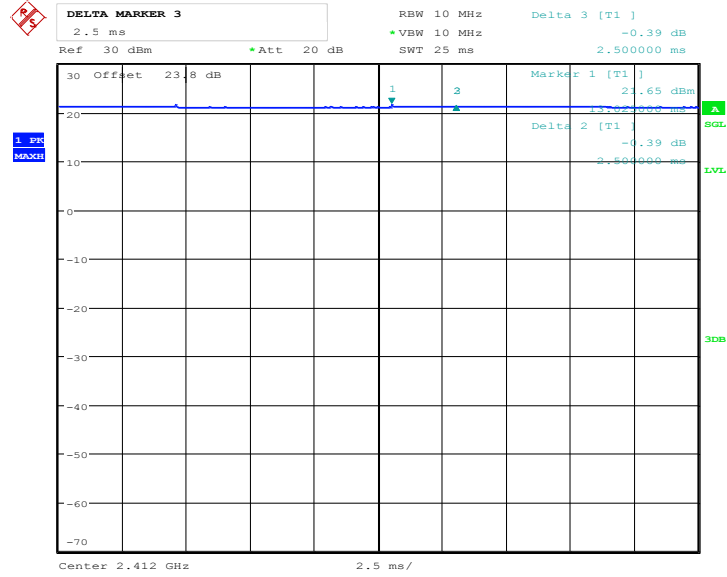

Date: 27.JUL.2016 04:32:54

802.11g

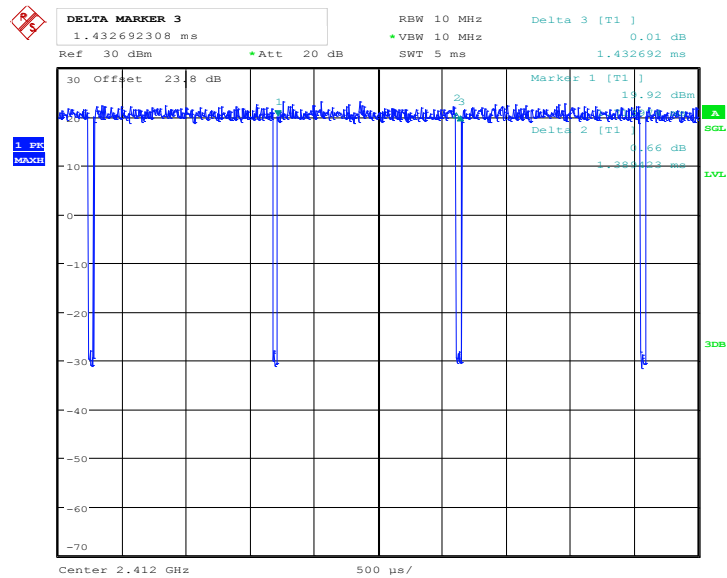

Date: 27.JUL.2016 04:34:43



802.11n HT20

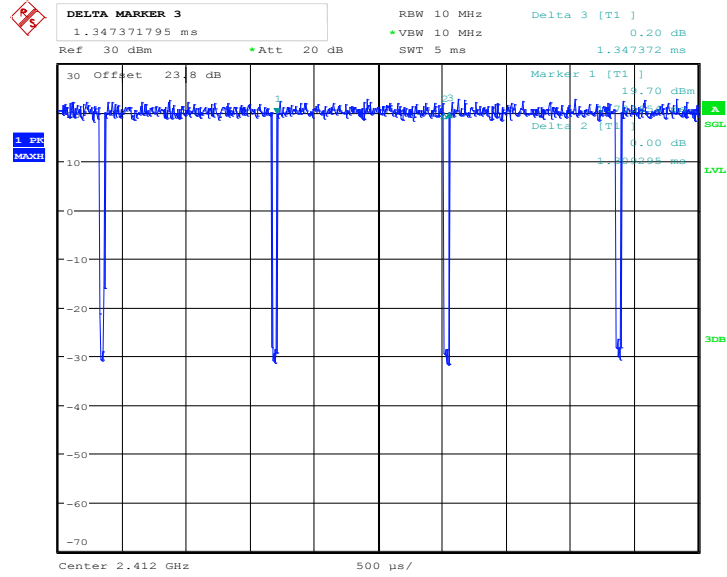

Date: 27.JUL.2016 04:37:06

802.11n HT40

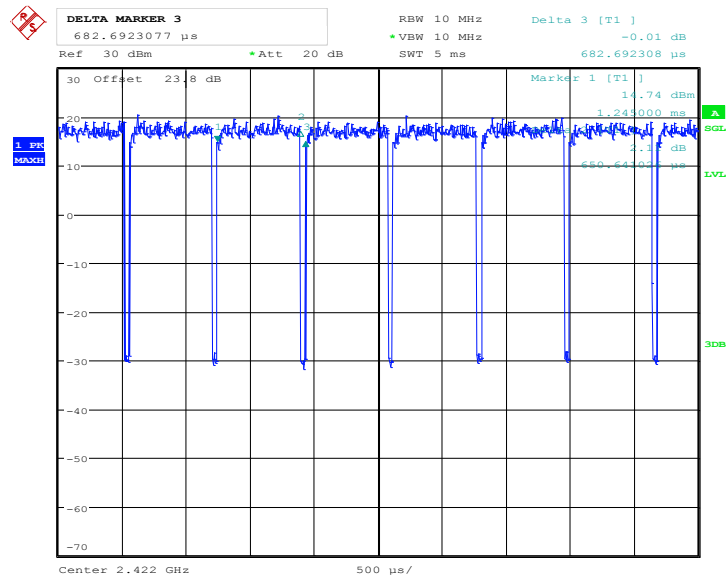

Date: 27.JUL.2016 04:38:35