



# FCC RF Test Report

**APPLICANT** : HTC Corporation  
**EQUIPMENT** : Smartphone  
**MODEL NAME** : 2PWD100  
**FCC ID** : NM82PWD100  
**STANDARD** : FCC 47 CFR Part 2, 22(H), 24(E), 27(L)  
**CLASSIFICATION** : PCS Licensed Transmitter Held to Ear (PCE)

The product was received on Jul. 25, 2016 and testing was completed on Aug. 30, 2016. We, SPORTON INTERNATIONAL INC., would like to declare that the tested sample has been evaluated in accordance with the test procedures given in ANSI / TIA / EIA-603-D-2010 and has been in compliance with the applicable technical standards.

The test results in this report apply exclusively to the tested model / sample. Without written approval of SPORTON INTERNATIONAL INC., the test report shall not be reproduced except in full.

Reviewed by: Joseph Lin / Supervisor

Approved by: Jones Tsai / Manager



## **SPORTON INTERNATIONAL INC.**

No. 52, Hwa Ya 1<sup>st</sup> Rd., Hwa Ya Technology Park, Kwei-Shan District, Tao Yuan City, Taiwan, R.O.C.



# TABLE OF CONTENTS

**REVISION HISTORY.....3**

**SUMMARY OF TEST RESULT .....4**

**1 GENERAL DESCRIPTION .....5**

    1.1 Applicant.....5

    1.2 Manufacturer .....5

    1.3 Product Feature of Equipment Under Test .....5

    1.4 Product Specification of Equipment Under Test .....6

    1.5 Modification of EUT .....6

    1.6 Maximum ERP/EIRP Power, Frequency Tolerance, and Emission Designator .....7

    1.7 Testing Location .....7

    1.8 Applicable Standards .....8

**2 TEST CONFIGURATION OF EQUIPMENT UNDER TEST .....9**

    2.1 Test Mode.....9

    2.2 Connection Diagram of Test System .....10

    2.3 Support Unit used in test configuration .....10

    2.4 Measurement Results Explanation Example .....11

**3 CONDUCTED TEST RESULT .....12**

    3.1 Measuring Instruments.....12

    3.2 Test Setup .....12

    3.3 Test Result of Conducted Test.....12

    3.4 Conducted Output Power .....13

    3.5 Peak-to-Average Ratio .....14

    3.6 99% Occupied Bandwidth and 26dB Bandwidth Measurement.....15

    3.7 Conducted Band Edge .....16

    3.8 Conducted Spurious Emission .....17

    3.9 Frequency Stability.....18

**4 RADIATED TEST ITEMS .....19**

    4.1 Measuring Instruments.....19

    4.2 Test Setup .....19

    4.3 Test Result of Radiated Test.....19

    4.4 Effective Radiated Power and Effective Isotropic Radiated Power Measurement .....20

    4.5 Field Strength of Spurious Radiation Measurement .....22

**5 LIST OF MEASURING EQUIPMENT .....23**

**6 UNCERTAINTY OF EVALUATION .....24**

**APPENDIX A. TEST RESULTS OF CONDUCTED TEST**

**APPENDIX B. TEST RESULTS OF RADIATED TEST**





## SUMMARY OF TEST RESULT

Report Section	FCC Rule	Description	Limit	Result	Remark
3.4	§2.1046	Conducted Output Power	Reporting Only	PASS	-
3.5	§24.232(d)	Peak-to-Average Ratio	< 13 dB	PASS	-
3.6	§2.1049 §22.917(b) §24.238(b) §27.53(g)	Occupied Bandwidth	Reporting Only	PASS	-
3.7	§2.1051 §22.917(a) §24.238(a) §27.53(h)	Band Edge Measurement	< 43+10log10(P[Watts])	PASS	-
3.8	§2.1051 §22.917(a) §24.238(a) §27.53(h)	Conducted Emission	< 43+10log10(P[Watts])	PASS	-
3.9	§2.1055 §22.355	Frequency Stability for Temperature & Voltage	< 2.5 ppm for Part 22	PASS	-
	§2.1055 §24.235 §27.54		Within Authorized Band		
4.4	§22.913(a)(2)	Effective Radiated Power	< 7 Watts	PASS	-
	§24.232(c)	Equivalent Isotropic Radiated Power	< 2 Watts	PASS	-
	§27.50(d)(4)	Equivalent Isotropic Radiated Power	< 1 Watts	PASS	-
4.5	§2.1053 §22.917(a) §24.238(a) §27.53(h)	Field Strength of Spurious Radiation	< 43+10log10(P[Watts])	PASS	Under limit 3.04 dB at 2544.000 MHz



# 1 General Description

## 1.1 Applicant

HTC Corporation

No. 23, Xinghua Rd., Taoyuan District, Taoyuan City, Taiwan 330

## 1.2 Manufacturer

HTC Corporation

No. 23, Xinghua Rd., Taoyuan District, Taoyuan City, Taiwan 330

## 1.3 Product Feature of Equipment Under Test

Product Feature	
Equipment	Smartphone
Model Name	2PWD100
FCC ID	NM82PWD100
Sample 1	EUT with battery 1 and LCD panel 1_black
Sample 2	EUT with battery 2 and LCD panel 2_white
EUT supports Radios application	GSM/EGPRS/WCDMA/HSPA/LTE/NFC WLAN 11a/b/g/n HT20/HT40 Bluetooth EDR/LE
EUT Stage	Production Unit

**Remark:**

1. The above EUT's information was declared by manufacturer. Please refer to the specifications or user's manual for more detailed description.
2. All the tests were performance with Sample 1.



### 1.4 Product Specification of Equipment Under Test

Standards-related Product Specification	
<b>Tx Frequency</b>	<b>GSM/GPRS/EDGE:</b> 850: 824.2 MHz ~ 848.8 MHz 1900: 1850.2 MHz ~ 1909.8MHz <b>WCDMA:</b> Band V: 826.4 MHz ~ 846.6 MHz Band II: 1852.4 MHz ~ 1907.6 MHz Band IV: 1712.4 MHz ~ 1752.6 MHz
<b>Rx Frequency</b>	<b>GSM/GPRS/EDGE:</b> 850: 869.2 MHz ~ 893.8 MHz 1900: 1930.2 MHz ~ 1989.8 MHz <b>WCDMA:</b> Band V: 871.4 MHz ~ 891.6 MHz Band II: 1932.4 MHz ~ 1987.6 MHz Band IV: 2112.4 MHz ~ 2152.6 MHz
<b>Maximum Output Power to Antenna</b>	<b>GSM/GPRS/EDGE:</b> 850: 32.30 dBm 1900: 29.37 dBm <b>WCDMA:</b> Band V: 23.43 dBm Band II: 22.81 dBm Band IV: 22.34 dBm
<b>Antenna Type</b>	Fixed Internal Antenna
<b>Type of Modulation</b>	GSM: GMSK GPRS: GMSK EDGE: GMSK / 8PSK WCDMA: BPSK (Uplink) HSDPA: 64QAM (Downlink) HSUPA: QPSK (Uplink)

### 1.5 Modification of EUT

No modifications are made to the EUT during all test items.

### 1.6 Maximum ERP/EIRP Power, Frequency Tolerance, and Emission Designator

FCC Rule	System	Type of Modulation	Maximum ERP/EIRP (W)		Frequency Tolerance (ppm)	Emission Designator
			Ant. 1	Ant. 2		
Part 22	GSM850 GSM	GMSK	0.2864	0.1483	0.0158 ppm	251KGXW
Part 22	GSM850 EDGE class 8	8PSK	0.0741	0.0326	0.0279 ppm	246KG7W
Part 22	WCDMA Band V RMC 12.2Kbps	BPSK	0.0505	0.0256	0.0145 ppm	4M17F9W
Part 24	GSM1900 GSM	GMSK	0.5768	0.8166	0.0205 ppm	247KGXW
Part 24	GSM1900 EDGE class 8	8PSK	0.2547	0.4074	0.0238 ppm	249KG7W
Part 24	WCDMA Band II RMC 12.2Kbps	BPSK	0.1585	0.1858	0.0070 ppm	4M16F9W
Part 27	WCDMA Band IV RMC 12.2Kbps	BPSK	0.1315	0.1159	0.0070 ppm	4M16F9W

### 1.7 Testing Location

Sporton Lab is accredited to ISO 17025 by Taiwan Accreditation Foundation (TAF code : 1190) and the FCC designation No. TW1022 under the FCC 2.948(e) by Mutual Recognition Agreement (MRA) in FCC Test.

<b>Test Site</b>	SPORTON INTERNATIONAL INC.
<b>Test Site Location</b>	No. 52, Hwa Ya 1 <sup>st</sup> Rd., Hwa Ya Technology Park, Kwei-Shan District, Tao Yuan City, Taiwan, R.O.C. TEL: +886-3-327-3456 FAX: +886-3-328-4978
<b>Test Site No.</b>	<b>Sporton Site No.</b> TH03-HY

<b>Test Site</b>	SPORTON INTERNATIONAL INC.
<b>Test Site Location</b>	No.58, Aly. 75, Ln. 564, Wenhua 3rd Rd. Guishan Dist, Taoyuan City, Taiwan (R.O.C.) TEL: +886-3-327-0868 FAX: +886-3-327-0855
<b>Test Site No.</b>	<b>Sporton Site No.</b> 03CH13-HY



## 1.8 Applicable Standards

According to the specifications of the manufacturer, the EUT must comply with the requirements of the following standards:

- ♦ 47 CFR Part 2, 22(H), 24(E), 27(L)
- ♦ ANSI / TIA / EIA-603-D-2010
- ♦ FCC KDB 971168 D01 Power Meas. License Digital Systems v02r02

### **Remark:**

1. All test items were verified and recorded according to the standards and without any deviation during the test.
2. This EUT has also been tested and complied with the requirements of FCC Part 15, Subpart B, recorded in a separate test report.





## 2 Test Configuration of Equipment Under Test

### 2.1 Test Mode

Antenna port conducted and radiated test items were performed according to KDB 971168 D01 Power Meas. License Digital Systems v02r02 with maximum output power.

Radiated measurements were performed with rotating EUT in different three orthogonal test planes to find the maximum emission.

Radiated emissions were investigated as following frequency range:

1. 30 MHz to 9000 MHz for GSM850 and WCDMA Band V.
2. 30 MHz to 18000 MHz for WCDMA Band IV.
3. 30 MHz to 19100 MHz for GSM1900 and WCDMA Band II.

All modes and data rates and positions were investigated.

Test modes are chosen to be reported as the worst case configuration below:

Test Modes		
Band	Radiated TCs	Conducted TCs
GSM 850	<ul style="list-style-type: none"> <li>■ GSM Link for Ant. 1</li> <li>■ GSM Link for Ant. 2</li> <li>■ EDGE class 8 Link for Ant. 1</li> <li>■ EDGE class 8 Link for Ant. 2</li> </ul>	<ul style="list-style-type: none"> <li>■ GSM Link</li> <li>■ EDGE class 8 Link</li> </ul>
GSM 1900	<ul style="list-style-type: none"> <li>■ GSM Link for Ant. 1</li> <li>■ GSM Link for Ant. 2</li> <li>■ EDGE class 8 Link for Ant. 1</li> <li>■ EDGE class 8 Link for Ant. 2</li> </ul>	<ul style="list-style-type: none"> <li>■ GSM Link</li> <li>■ EDGE class 8 Link</li> </ul>
WCDMA Band V	<ul style="list-style-type: none"> <li>■ RMC 12.2Kbps Link for Ant. 1</li> <li>■ RMC 12.2Kbps Link for Ant. 2</li> </ul>	<ul style="list-style-type: none"> <li>■ RMC 12.2Kbps Link</li> </ul>
WCDMA Band II	<ul style="list-style-type: none"> <li>■ RMC 12.2Kbps Link for Ant. 1</li> <li>■ RMC 12.2Kbps Link for Ant. 2</li> </ul>	<ul style="list-style-type: none"> <li>■ RMC 12.2Kbps Link</li> </ul>
WCDMA Band IV	<ul style="list-style-type: none"> <li>■ RMC 12.2Kbps Link for Ant. 1</li> <li>■ RMC 12.2Kbps Link for Ant. 2</li> </ul>	<ul style="list-style-type: none"> <li>■ RMC 12.2Kbps Link</li> </ul>

## 2.2 Connection Diagram of Test System

<EUT without accessory>

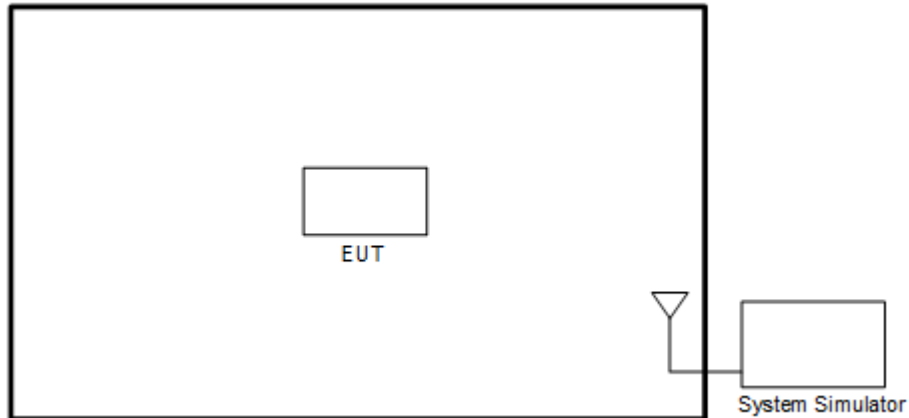

<EUT with accessory>

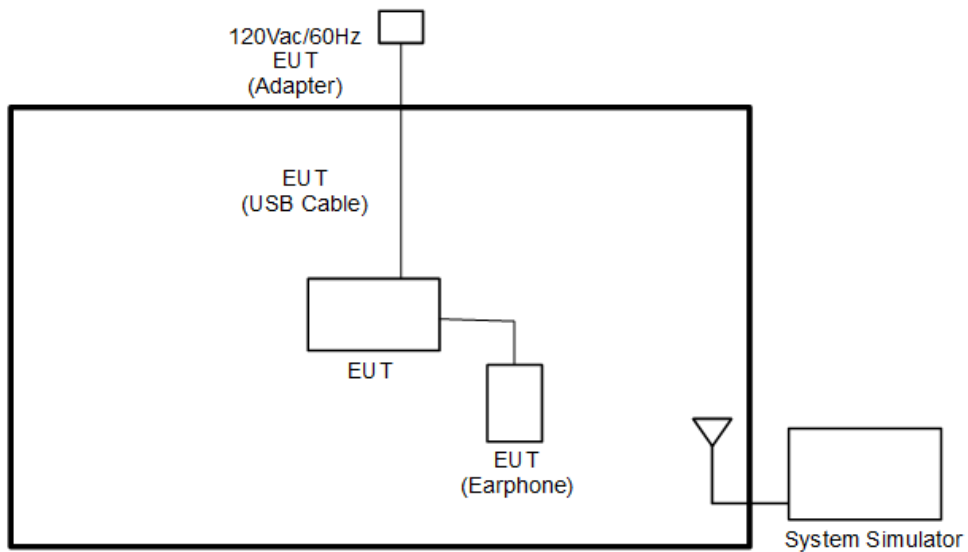

## 2.3 Support Unit used in test configuration

Item	Equipment	Trade Name	Model No.	FCC ID	Data Cable	Power Cord
1.	System Simulator	R&S	CMU 200	N/A	N/A	Unshielded, 1.8 m



## **2.4 Measurement Results Explanation Example**

**For all conducted test items:**

The offset level is set in the spectrum analyzer to compensate the RF cable loss and attenuator factor between RF conducted output port and spectrum analyzer. With the offset compensation, the spectrum analyzer reading level will be exactly the RF output level.

The spectrum analyzer offset is derived from RF cable loss and attenuator factor.

*Offset = RF cable loss + attenuator factor.*

The following shows an offset computation example with RF cable loss 4.2 dB and a 10dB attenuator.

Example :

$$\begin{aligned} \text{Offset(dB)} &= \text{RF cable loss(dB)} + \text{attenuator factor(dB)}. \\ &= 4.2 + 10 = 14.2 \text{ (dB)} \end{aligned}$$

### 3 Conducted Test Result

#### 3.1 Measuring Instruments

See list of measuring instruments of this test report.

#### 3.2 Test Setup

##### 3.2.1 Conducted Output Power

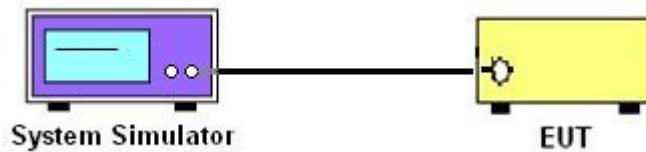

##### 3.2.2 Peak-to-Average Ratio, Occupied Bandwidth, Conducted Band-Edge and Conducted Spurious Emission

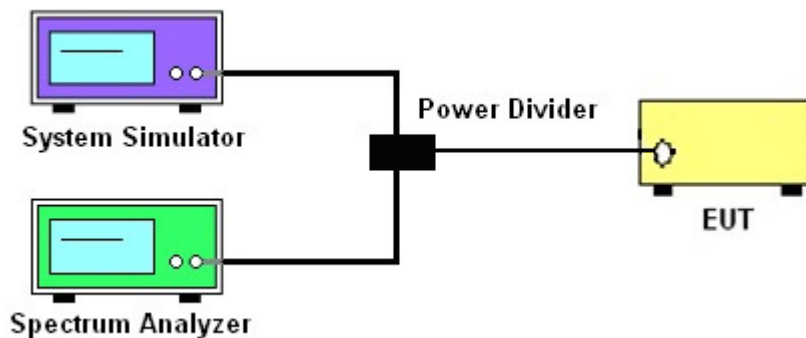

##### 3.2.3 Frequency Stability

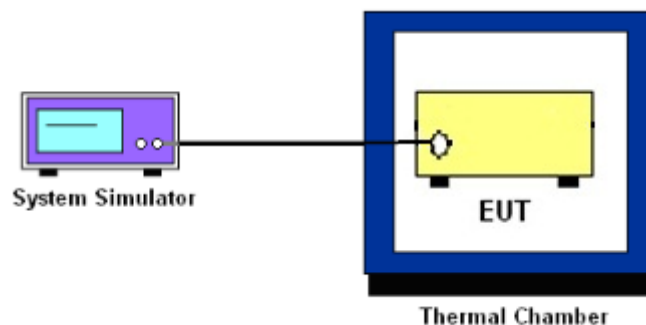

### 3.3 Test Result of Conducted Test

Please refer to Appendix A.



## **3.4 Conducted Output Power**

### **3.4.1 Description of the Conducted Output Power**

A system simulator was used to establish communication with the EUT. Its parameters were set to enforce EUT transmitting at the maximum power. The measured power in the radio frequency on the transmitter output terminals shall be reported.

### **3.4.2 Test Procedures**

1. The transmitter output port was connected to the system simulator.
2. Set EUT at maximum power through system simulator.
3. Select lowest, middle, and highest channels for each band and different modulation.
4. Measure the maximum burst average power for GSM and maximum average power for other modulation signal.



## **3.5 Peak-to-Average Ratio**

### **3.5.1 Description of the PAR Measurement**

The peak-to-average ratio (PAR) of the transmission may not exceed 13 dB.

### **3.5.2 Test Procedures**

1. The testing follows FCC KDB 971168 D01 v02r02 Section 5.7.1.
2. The EUT was connected to spectrum analyzer and system simulator via a power divider.
3. Set EUT to transmit at maximum output power.
4. When the duty cycle is less than 98%, then signal gating will be implemented on the spectrum analyzer by triggering from the system simulator.
5. Set the CCDF (Complementary Cumulative Distribution Function) option of the spectrum analyzer.  
Record the maximum PAPR level associated with a probability of 0.1%.



## 3.6 99% Occupied Bandwidth and 26dB Bandwidth Measurement

### 3.6.1 Description of 99% Occupied Bandwidth and 26dB Bandwidth Measurement

The occupied bandwidth is the width of a frequency band such that, below the lower and above the upper frequency limits, the mean powers emitted are each equal to a specified percentage 0.5% of the total mean transmitted power.

The 26 dB emission bandwidth is defined as the frequency range between two points, one above and one below the carrier frequency, at which the spectral density of the emission is attenuated 26 dB below the maximum in-band spectral density of the modulated signal. Spectral density (power per unit bandwidth) is to be measured with a detector of resolution bandwidth equal to approximately 1.0% of the emission bandwidth.

### 3.6.2 Test Procedures

1. The testing follows FCC KDB 971168 v02r02 Section 4.2.
2. The EUT was connected to spectrum analyzer and system simulator via a power divider.
3. The spectrum analyzer center frequency is set to the nominal EUT channel center frequency. The span range for the spectrum analyzer shall be between two and five times the anticipated OBW.
4. The nominal resolution bandwidth (RBW) shall be in the range of 1 to 5 % of the anticipated OBW, and the VBW shall be at least 3 times the RBW.
5. Set the detection mode to peak, and the trace mode to max hold.
6. Determine the reference value: Set the EUT to transmit a modulated signal. Allow the trace to stabilize. Set the spectrum analyzer marker to the highest level of the displayed trace.  
(this is the reference value)
7. Determine the “-26 dB down amplitude” as equal to (Reference Value – X).
8. Place two markers, one at the lowest and the other at the highest frequency of the envelope of the spectral display such that each marker is at or slightly below the “-X dB down amplitude” determined in step 6. If a marker is below this “-X dB down amplitude” value it shall be placed as close as possible to this value. The OBW is the positive frequency difference between the two markers.
9. Use the 99 % power bandwidth function of the spectrum analyzer and report the measured bandwidth.



### 3.7 Conducted Band Edge

#### 3.7.1 Description of Conducted Band Edge Measurement

The power of any emission outside of the authorized operating frequency ranges must be lower than the transmitter power (P) by a factor of at least  $43 + 10 \log (P)$  dB.

#### 3.7.2 Test Procedures

1. The testing follows FCC KDB 971168 D01 v02r02 Section 6.0.
2. The EUT was connected to the spectrum analyzer and system simulator via a power divider.
3. The RF output of EUT was connected to the spectrum analyzer by an RF cable and attenuator. The path loss was compensated to the results for each measurement.
4. The band edges of low and high channels for the highest RF powers were measured.
5. The RF fundamental frequency should be excluded against the limit line in the operating frequency band.
6. The limit line is derived from  $43 + 10\log(P)$  dB below the transmitter power P(Watts)  
=  $P(W) - [43 + 10\log(P)]$  (dB)  
=  $[30 + 10\log(P)]$  (dBm) -  $[43 + 10\log(P)]$  (dB)  
= -13dBm.





### 3.8 Conducted Spurious Emission

#### 3.8.1 Description of Conducted Spurious Emission Measurement

The power of any emission outside of the authorized operating frequency ranges must be lower than the transmitter power (P) by a factor of at least  $43 + 10 \log (P)$  dB.

It is measured by means of a calibrated spectrum analyzer and scanned from 30 MHz up to a frequency including its 10<sup>th</sup> harmonic.

#### 3.8.2 Test Procedures

1. The testing follows FCC KDB 971168 D01 v02r02 Section 6.0.
2. The EUT was connected to the spectrum analyzer and system simulator via a power divider.
3. The RF output of EUT was connected to the spectrum analyzer by an RF cable and attenuator. The path loss was compensated to the results for each measurement.
4. The middle channel for the highest RF power within the transmitting frequency was measured.
5. The conducted spurious emission for the whole frequency range was taken.
6. The RF fundamental frequency should be excluded against the limit line in the operating frequency band.
7. The limit line is derived from  $43 + 10\log(P)$  dB below the transmitter power P(Watts)  
=  $P(W) - [43 + 10\log(P)]$  (dB)  
=  $[30 + 10\log(P)]$  (dBm) -  $[43 + 10\log(P)]$  (dB)  
= -13dBm.



### 3.9 Frequency Stability

#### 3.9.1 Description of Frequency Stability Measurement

The frequency stability shall be measured by variation of ambient temperature and variation of primary supply voltage to ensure that the fundamental emission stays within the authorized frequency block. The frequency stability of the transmitter shall be maintained within  $\pm 0.00025\%$  ( $\pm 2.5\text{ppm}$ ) of the center frequency.

#### 3.9.2 Test Procedures for Temperature Variation

1. The testing follows FCC KDB 971168 D01 v02r02 Section 9.0.
2. The EUT was set up in the thermal chamber and connected with the system simulator.
3. With power OFF, the temperature was decreased to  $-30^{\circ}\text{C}$  and the EUT was stabilized before testing. Power was applied and the maximum change in frequency was recorded within one minute.
4. With power OFF, the temperature was raised in  $10^{\circ}\text{C}$  steps up to  $50^{\circ}\text{C}$ . The EUT was stabilized at each step for at least half an hour. Power was applied and the maximum frequency change was recorded within one minute.

#### 3.9.3 Test Procedures for Voltage Variation

1. The testing follows FCC KDB 971168 D01 v02r02 Section 9.0.
2. The EUT was placed in a temperature chamber at  $20\pm 5^{\circ}\text{C}$  and connected with the system simulator.
3. The power supply voltage to the EUT was varied from 85% to 115% of the nominal value measured at the input to the EUT.
4. The variation in frequency was measured for the worst case.

## 4 Radiated Test Items

### 4.1 Measuring Instruments

See list of measuring instruments of this test report.

### 4.2 Test Setup

#### 4.2.1 For radiated test from 30MHz to 1GHz

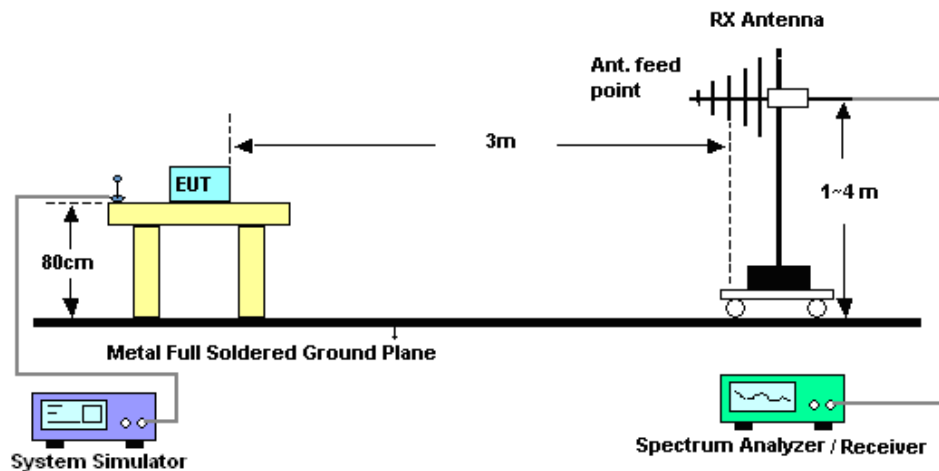

#### 4.2.2 For radiated test above 1GHz

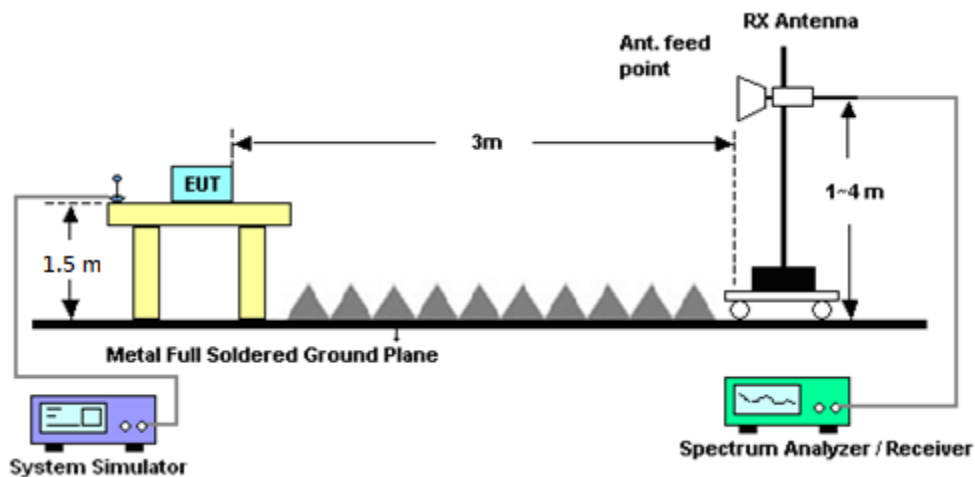

## 4.3 Test Result of Radiated Test

Please refer to Appendix B.



## **4.4 Effective Radiated Power and Effective Isotropic Radiated Power Measurement**

### **4.4.1 Description of the ERP/EIRP Measurement**

The substitution method, in ANSI / TIA / EIA-603-D-2010, was used for ERP/EIRP measurement, and the spectrum analyzer configuration follows KDB 971168 D01 Power Meas. License Digital Systems v02r02. The ERP of mobile transmitters must not exceed 7 Watts (Cellular Band) and the EIRP of mobile transmitters are limited to 2 Watts (PCS Band) and 1 Watts (AWS Band).

### **4.4.2 Test Procedures**

1. The testing follows FCC KDB 971168 D01 v02r02 Section 5.2.1. (for CDMA/WCDMA), Section 5.2.2.2 (for GSM/GPRS/EDGE) and ANSI / TIA-603-D-2010 Section 2.2.17.
2. The EUT was placed on a non-conductive rotating platform (0.8 meters for frequency below 1GHz and 1.5 meter for frequency above 1GHz) in a semi-anechoic chamber. The radiated emission at the fundamental frequency was measured at 3 m with a test antenna and a spectrum analyzer with RMS detector per section 5. of KDB 971168 D01.
3. During the measurement, the system simulator parameters were set to force the EUT transmitting at maximum output power. The maximum emission was recorded from analyzer power level (LVL) from the 360 degrees rotation of the turntable and the test antenna raised and lowered over a range from 1 to 4 meters in both horizontally and vertically polarized orientations.
4. Effective Isotropic Radiated Power (EIRP) was measured by substitution method according to TIA/EIA-603-D. The EUT was replaced by the substitution antenna at same location, and then a known power from S.G. was applied into the dipole antenna through a Tx cable, and then recorded the maximum Analyzer reading through raised and lowered the test antenna. The correction factor (in dB) = S.G. - Tx Cable loss + Substitution antenna gain - Analyzer reading. Then the EUT's EIRP was calculated with the correction factor,  $EIRP = LVL + \text{Correction factor}$  and  $ERP = EIRP - 2.15$ . Take the record of the output power at substitution antenna.



	GSM/GPRS/EDGE	WCDMA/HSPA
SPAN	500kHz	10MHz
RBW	10kHz	100kHz
VBW	30kHz	300kHz
Detector	RMS	RMS
Trace	Average	Average
Average Type	Power	Power
Sweep Count	100	100



## 4.5 Field Strength of Spurious Radiation Measurement

### 4.5.1 Description of Field Strength of Spurious Radiated Measurement

The power of any emission outside of the authorized operating frequency ranges must be attenuated below the transmitter power (P) by a factor of at least  $43 + 10 \log (P)$  dB. The spectrum is scanned from 30 MHz up to a frequency including its 10th harmonic.

### 4.5.2 Test Procedures

1. The testing follows FCC KDB 971168 D01 v02r02 Section 5.8 and ANSI / TIA-603-D-2010 Section 2.2.12.
2. The EUT was placed on a rotatable wooden table 0.8 meters for frequency below 1GHz and 1.5 meter for frequency above 1GHz above the ground.
3. The EUT was set 3 meters from the receiving antenna, which was mounted on the antenna tower.
4. The table was rotated 360 degrees to determine the position of the highest spurious emission.
5. The height of the receiving antenna is varied between one meter and four meters to search for the maximum spurious emission for both horizontal and vertical polarizations.
6. Make the measurement with the spectrum analyzer's RBW = 1MHz, VBW = 3MHz, taking record of maximum spurious emission.
7. A horn antenna was substituted in place of the EUT and was driven by a signal generator.
8. Tune the output power of signal generator to the same emission level with EUT maximum spurious emission.
9. Taking the record of output power at antenna port.
10. Repeat step 7 to step 8 for another polarization.
11.  $EIRP \text{ (dBm)} = S.G. \text{ Power} - Tx \text{ Cable Loss} + Tx \text{ Antenna Gain}$
12.  $ERP \text{ (dBm)} = EIRP - 2.15$
13. The RF fundamental frequency should be excluded against the limit line in the operating frequency band.
14. The limit line is derived from  $43 + 10\log(P)$  dB below the transmitter power P(Watts)  
 $= P(W) - [43 + 10\log(P)] \text{ (dB)}$   
 $= [30 + 10\log(P)] \text{ (dBm)} - [43 + 10\log(P)] \text{ (dB)}$   
 $= -13dBm.$



## 5 List of Measuring Equipment

Instrument	Manufacturer	Model No.	Serial No.	Characteristics	Calibration Date	Test Date	Due Date	Remark
Spectrum Analyzer	Rohde & Schwarz	FSP30	101329	9kHz~30GHz	Jun. 27, 2016	Aug. 22, 2016	Jun. 26, 2017	Conducted (TH03-HY)
Temperature Chamber	ESPEC	SU-641	92013721	-30°C ~70°C	Nov. 20, 2015	Aug. 22, 2016	Nov. 19, 2016	Conducted (TH03-HY)
Programmable Power Supply	GW Instek	PSS-2005	EL883644	Voltage:0~20V;Current:0~5A	Nov. 26, 2015	Aug. 22, 2016	Nov. 25, 2016	Conducted (TH03-HY)
Base Station (Measure)	Rohde & Schwarz	CMU200	117995	GSM / GPRS / WCDMA / CDMA	Aug. 03, 2016	Aug. 22, 2016	Aug,04, 2017	Conducted (TH03-HY)
Horn Antenna	SCHWARZBECK	BBHA 9120D	9120D-1328	1GHz ~ 18GHz	Nov. 02, 2015	Aug. 22 2016 ~ Aug. 30 2016	Nov. 01, 2016	Radiation (03CH13-HY)
SHF-EHF Horn Antenna	SCHWARZBECK	BBHA 9170	BBHA9170576	18GHz ~ 40GHz	Apr. 15, 2016	Aug. 22 2016 ~ Aug. 30 2016	Apr. 14, 2017	Radiation (03CH13-HY)
Amplifier	Sonoma-Instrument	310 N	187282	10MHz~1GHz	Dec. 31, 2015	Aug. 22 2016 ~ Aug. 30 2016	Dec. 30, 2016	Radiation (03CH13-HY)
Bilog Antenna	TESEQ	CBL 6111D	40103	30MHz to 1GHz	Jan. 13, 2016	Aug. 22 2016 ~ Aug. 30 2016	Jan. 12, 2017	Radiation (03CH13-HY)
Horn Antenna	SCHWARZBECK	BBHA 9120D	9120D-1241	1GHz ~ 18GHz	Apr. 25, 2016	Aug. 22 2016 ~ Aug. 30 2016	Apr. 24, 2017	Radiation (03CH13-HY)
Preamplifier	MITEQ	AMF-7D-00 101800-30-1	1590074	1GHz~18GHz	Jun. 27, 2016	Aug. 22 2016 ~ Aug. 30 2016	Jun. 26, 2017	Radiation (03CH13-HY)
Preamplifier	MITEQ	JS44-18004 000-33-8P	1840917	18GHz ~ 40GHz	Jun. 14, 2016	Aug. 22 2016 ~ Aug. 30 2016	Jun. 13, 2017	Radiation (03CH13-HY)
Preamplifier	Keysight	83017A	MY53270147	1GHz~26.5GHz	Jan. 30, 2016	Aug. 22 2016 ~ Aug. 30 2016	Jan. 29, 2017	Radiation (03CH13-HY)
Spectrum Analyzer	Keysight	N9010A	MY55370526	N/A	Mar. 14, 2016	Aug. 22 2016 ~ Aug. 30 2016	Mar. 13, 2017	Radiation (03CH13-HY)
Antenna Mast	EMEC	AM-BS-450 0-B	N/A	1m~4m	N/A	Aug. 22 2016 ~ Aug. 30 2016	N/A	Radiation (03CH13-HY)
Turn Table	EMEC	TT2000	N/A	0~360 Degree	N/A	Aug. 22 2016 ~ Aug. 30 2016	N/A	Radiation (03CH13-HY)
SHF-EHF Horn Antenna	SCHWARZBECK	BBHA 9170	BBHA9170584	18GHz- 40GHz	Nov. 02, 2015	Aug. 22 2016 ~ Aug. 30 2016	Nov. 01, 2016	Radiation (03CH13-HY)
Signal Generator	Rohde & Schwarz	SMF100A	101107	100kHz~40GHz	May 19, 2016	Aug. 22 2016 ~ Aug. 30 2016	May 18, 2017	Radiation (03CH13-HY)



## 6 Uncertainty of Evaluation

### Uncertainty of Radiated Emission Measurement (30 MHz ~ 1000 MHz)

Measuring Uncertainty for a Level of Confidence of 95% ( $U = 2Uc(y)$ )	4.9
---	-----

### Uncertainty of Radiated Emission Measurement (1 GHz ~ 40 GHz)

Measuring Uncertainty for a Level of Confidence of 95% ( $U = 2Uc(y)$ )	5.4
---	-----





## Appendix A. Test Results of Conducted Test

### Conducted Output Power(Average power)

Conducted Power (*Unit: dBm)						
Band	GSM850			GSM1900		
Channel	128	189	251	512	661	810
Frequency	824.2	836.4	848.8	1850.2	1880.0	1909.8
GSM	32.12	32.11	32.30	29.29	29.37	29.14
GPRS class 8	32.11	32.11	32.29	29.28	29.36	29.13
GPRS class 10	31.38	31.36	31.57	28.54	28.63	28.40
GPRS class 11	29.68	29.62	29.80	26.76	26.86	26.62
GPRS class 12	28.62	28.57	28.75	25.69	25.80	25.55
EGPRS class 8	25.96	25.95	26.02	25.14	25.08	25.10
EGPRS class 10	25.33	25.33	25.38	24.50	24.44	24.50
EGPRS class 11	24.60	24.61	24.66	23.72	23.64	23.73
EGPRS class 12	24.39	24.32	24.46	22.30	22.22	22.22

Conducted Power (*Unit: dBm)									
Band	WCDMA Band V			WCDMA Band II			WCDMA Band IV		
Channel	4132	4182	4233	9262	9400	9538	1312	1413	1513
Frequency	826.4	836.4	846.6	1852.4	1880	1907.6	1712.4	1732.6	1752.6
RMC 12.2K	23.43	23.33	23.35	22.53	22.71	22.81	23.34	23.32	23.09
HSDPA Subtest-1	22.36	22.26	22.23	21.57	21.81	21.89	22.34	22.27	22.09
HSDPA Subtest-2	22.34	22.25	22.23	21.55	21.80	21.87	22.34	22.33	22.08
HSDPA Subtest-3	21.87	21.79	21.73	21.10	21.31	21.29	21.88	21.88	21.57
HSDPA Subtest-4	21.85	21.78	21.72	21.09	21.30	21.27	21.86	21.83	21.56
HSUPA Subtest-1	20.31	20.28	20.24	19.58	19.77	19.75	20.39	20.30	20.10
HSUPA Subtest-2	20.33	20.26	20.23	19.54	19.74	19.72	20.37	20.29	20.08
HSUPA Subtest-3	21.36	21.36	21.23	20.57	20.82	20.83	21.40	21.31	21.07
HSUPA Subtest-4	19.87	19.85	19.81	19.13	19.32	19.35	19.92	19.85	19.63
HSUPA Subtest-5	21.31	21.18	21.14	20.59	20.84	20.80	21.41	21.32	21.10



# A1. GSM

## Peak-to-Average Ratio

Mode	GSM850		Limit: 13dB
Mod.	GSM	EDGE class 8	Result
Lowest CH	0.12	3.04	PASS
Middle CH	0.16	3.20	
Highest CH	0.16	3.08	

Mode	GSM1900		Limit: 13dB
Mod.	GSM	EDGE class 8	Result
Lowest CH	0.16	3.12	PASS
Middle CH	0.16	3.24	
Highest CH	0.12	3.20	

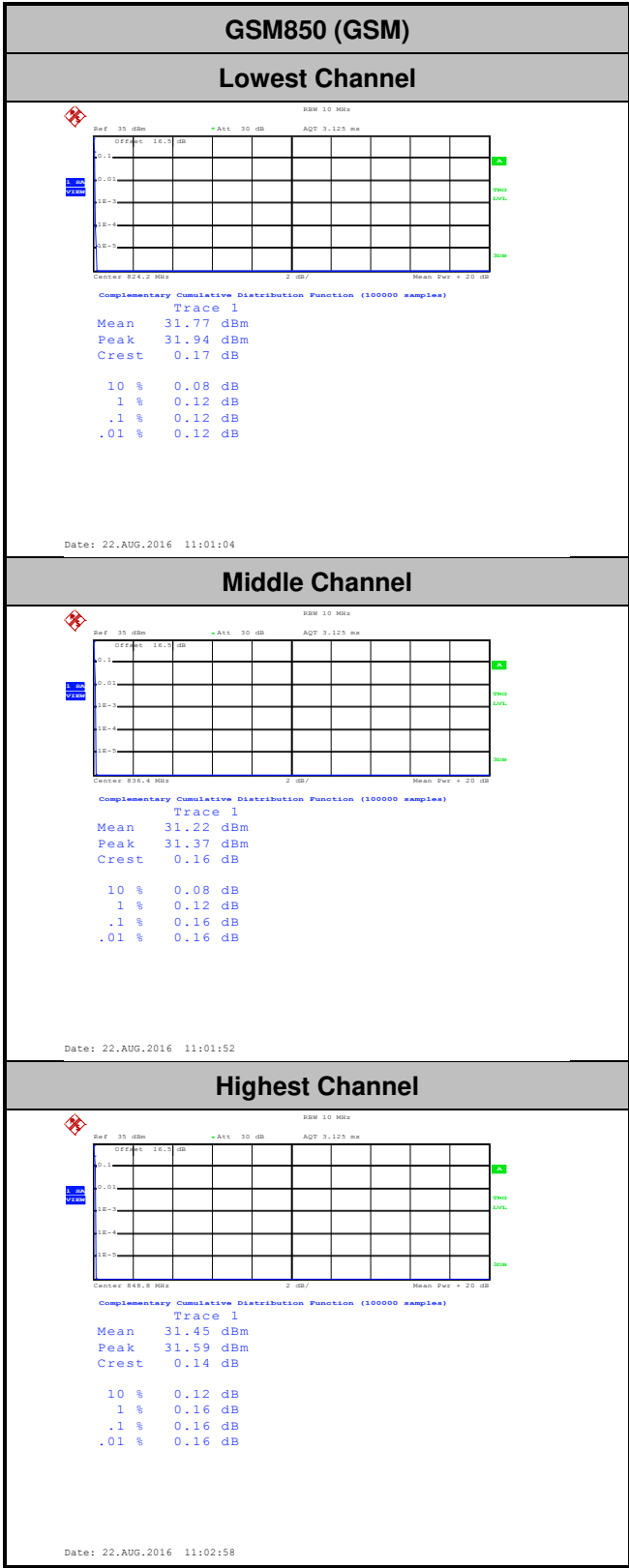

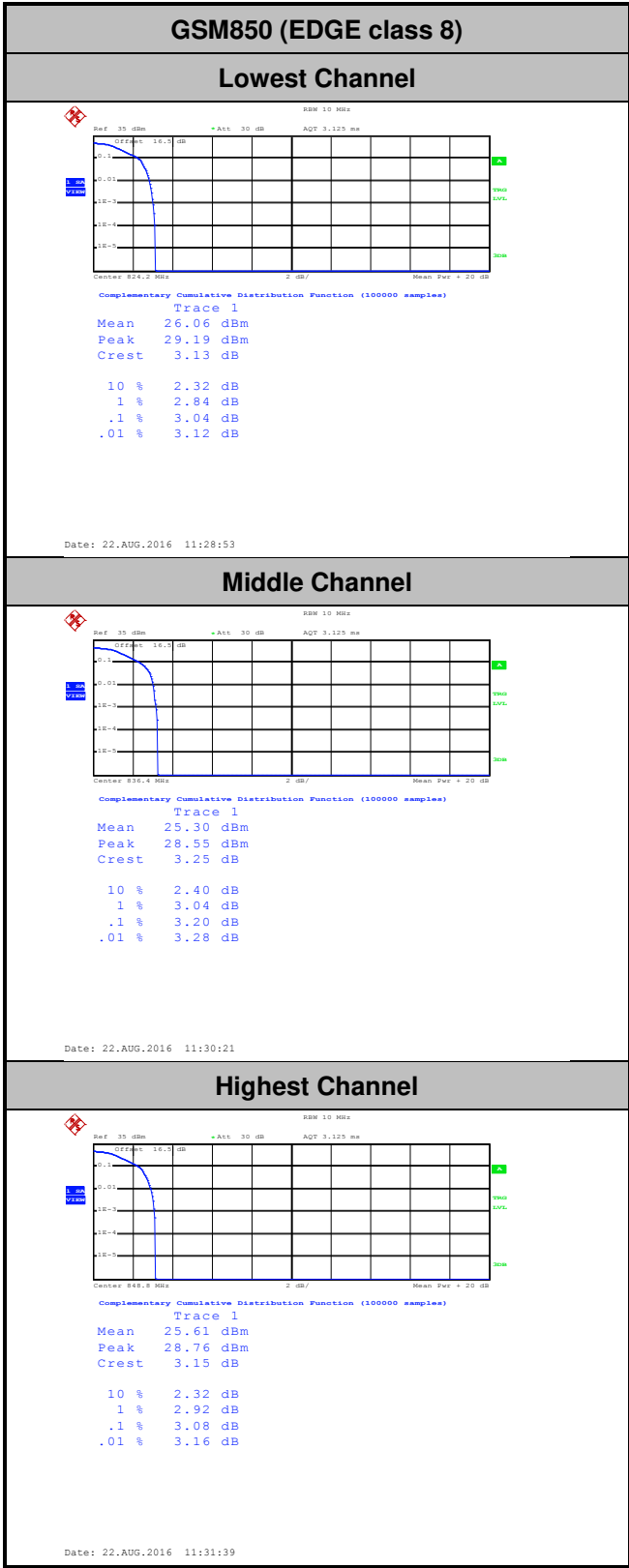



### GSM1900 (GSM)

#### Lowest Channel

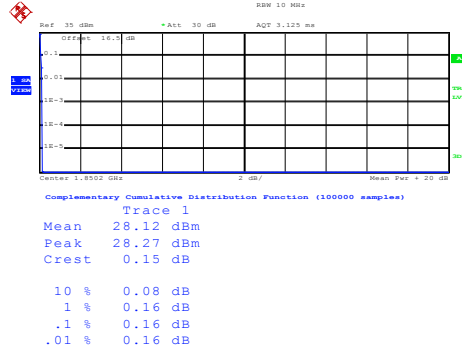

Date: 22.AUG.2016 11:48:56

#### Middle Channel

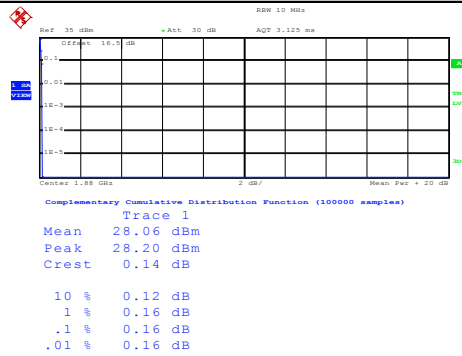

Date: 22.AUG.2016 11:49:37

#### Highest Channel

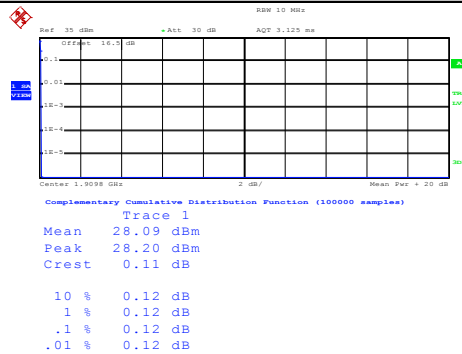

Date: 22.AUG.2016 11:50:20



### GSM1900 (EDGE class 8)

#### Lowest Channel

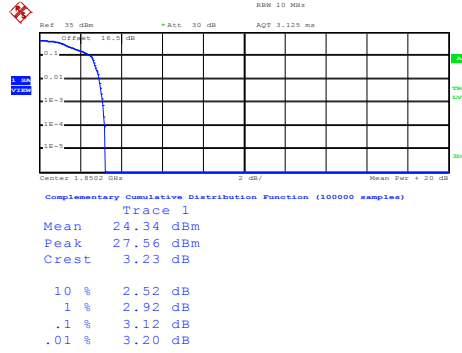

Date: 22.AUG.2016 12:03:10

#### Middle Channel

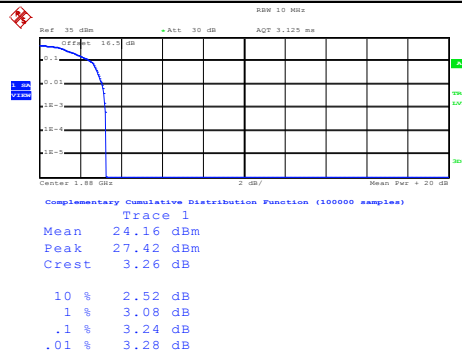

Date: 22.AUG.2016 12:04:18

#### Highest Channel

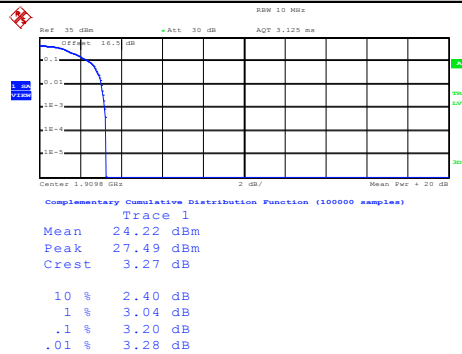

Date: 22.AUG.2016 12:05:42



**26dB Bandwidth**

Mode	GSM850	
Mod.	GSM	EDGE class 8
Lowest CH	0.308	0.286
Middle CH	0.318	0.279
Highest CH	0.315	0.299

Mode	GSM1900	
Mod.	GSM	EDGE class 8
Lowest CH	0.299	0.294
Middle CH	0.300	0.295
Highest CH	0.306	0.299



### GSM850 (GSM)

#### Lowest Channel

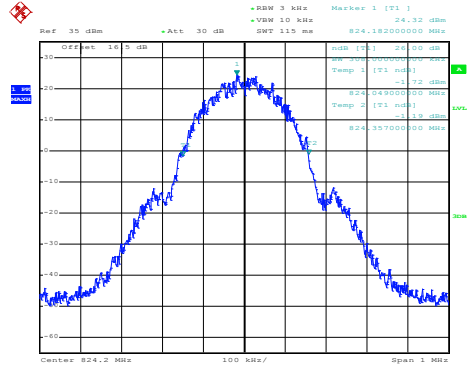

Date: 22.AUG.2016 10:50:08

#### Middle Channel

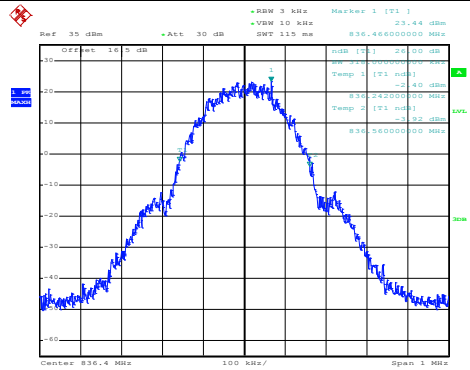

Date: 22.AUG.2016 10:50:36

#### Highest Channel

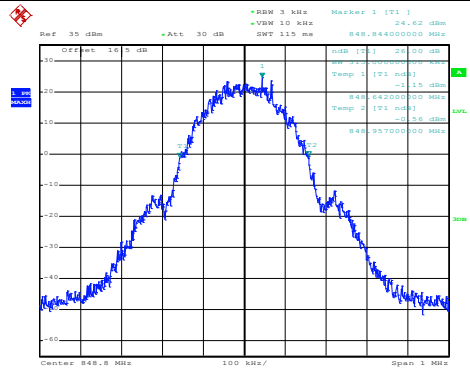

Date: 22.AUG.2016 10:51:04



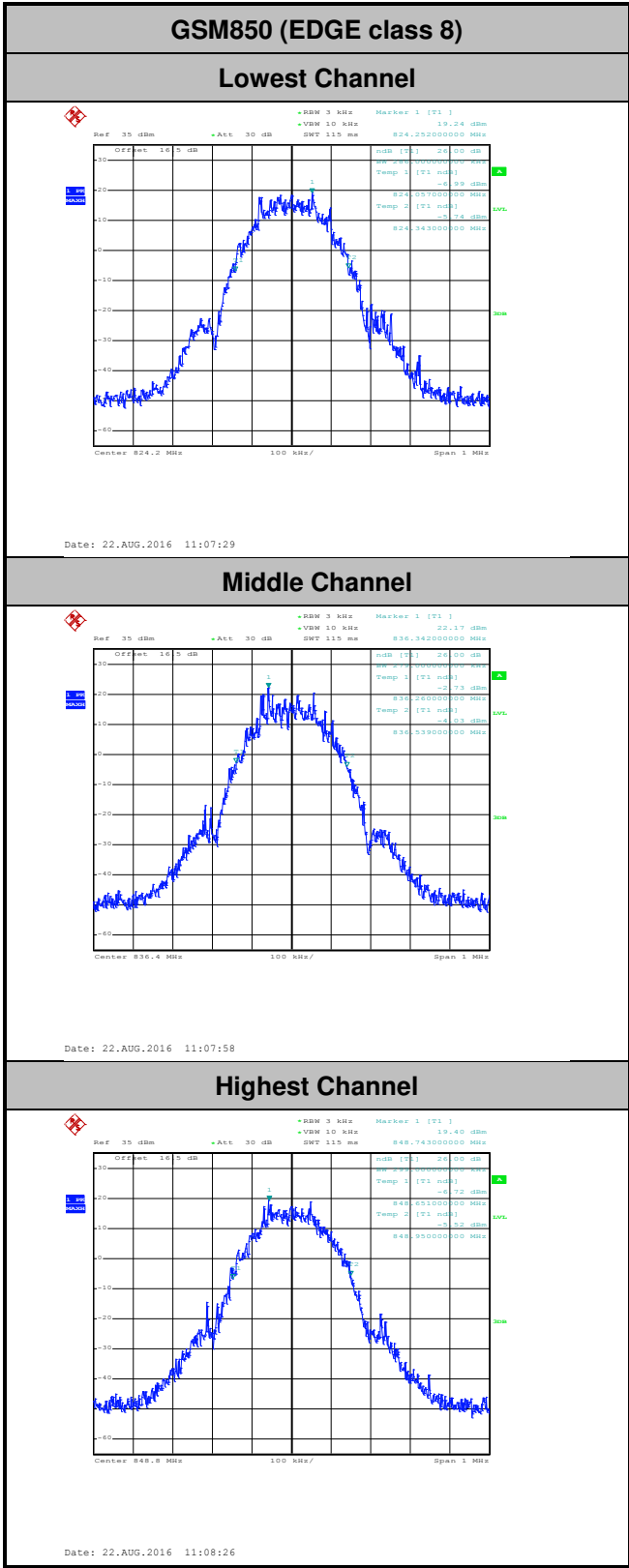



### GSM1900 (GSM)

#### Lowest Channel

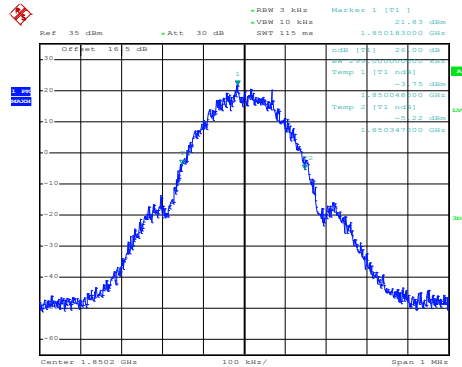

Date: 22.AUG.2016 11:38:16

#### Middle Channel

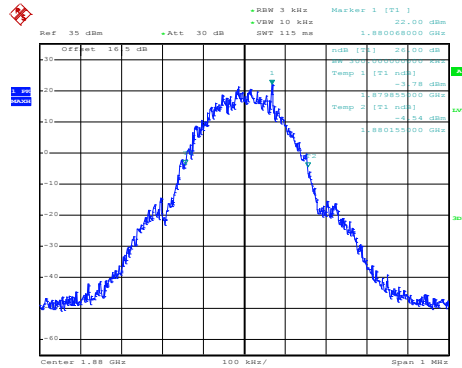

Date: 22.AUG.2016 11:38:44

#### Highest Channel

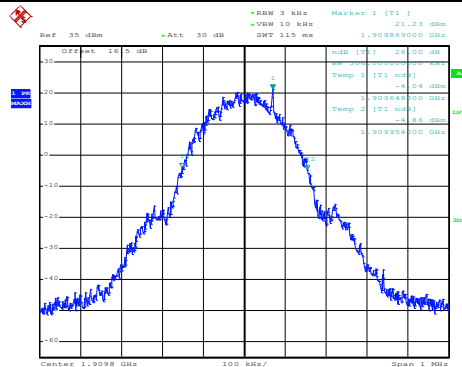

Date: 22.AUG.2016 11:39:12



### GSM1900 (EDGE class 8)

#### Lowest Channel

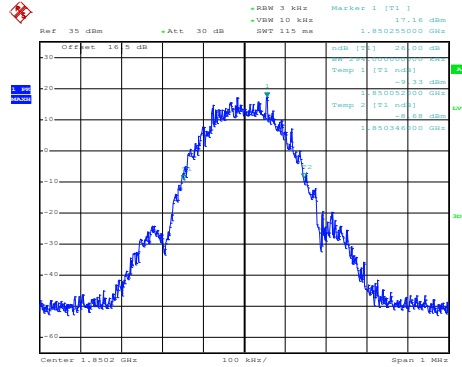

Date: 22.AUG.2016 11:52:18

#### Middle Channel

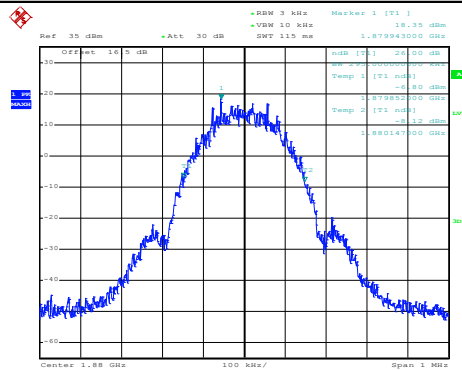

Date: 22.AUG.2016 11:52:46

#### Highest Channel

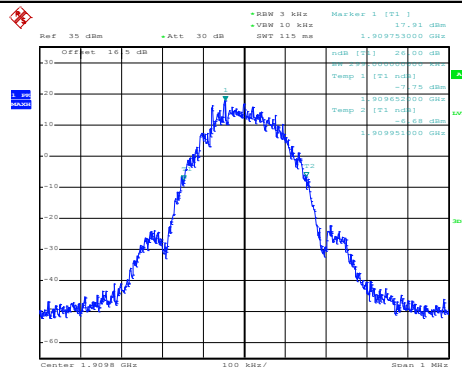

Date: 22.AUG.2016 11:53:15



### Occupied Bandwidth

Mode	GSM850	
Mod.	GSM	EDGE class 8
Lowest CH	0.251	0.241
Middle CH	0.250	0.246
Highest CH	0.248	0.239

Mode	GSM1900	
Mod.	GSM	EDGE class 8
Lowest CH	0.247	0.235
Middle CH	0.244	0.249
Highest CH	0.246	0.244



### GSM850 (GSM)

#### Lowest Channel

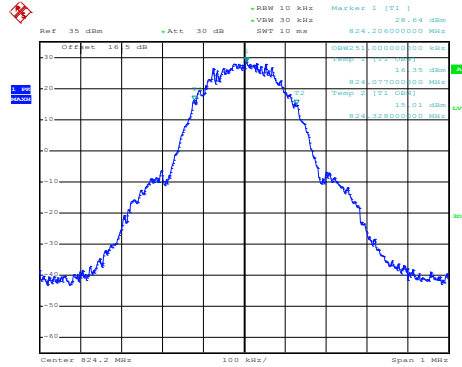

Date: 22.AUG.2016 10:51:41

#### Middle Channel

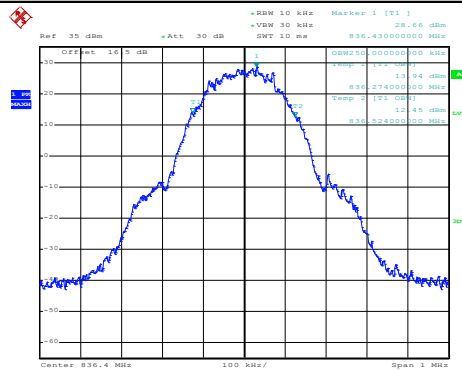

Date: 22.AUG.2016 10:52:09

#### Highest Channel

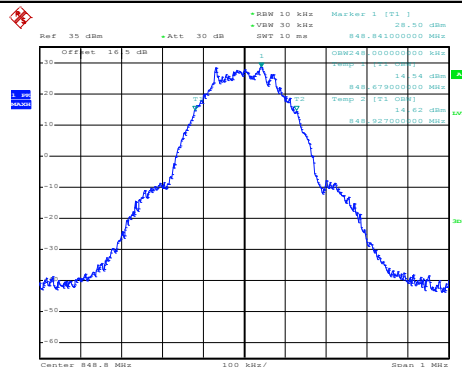

Date: 22.AUG.2016 10:52:37

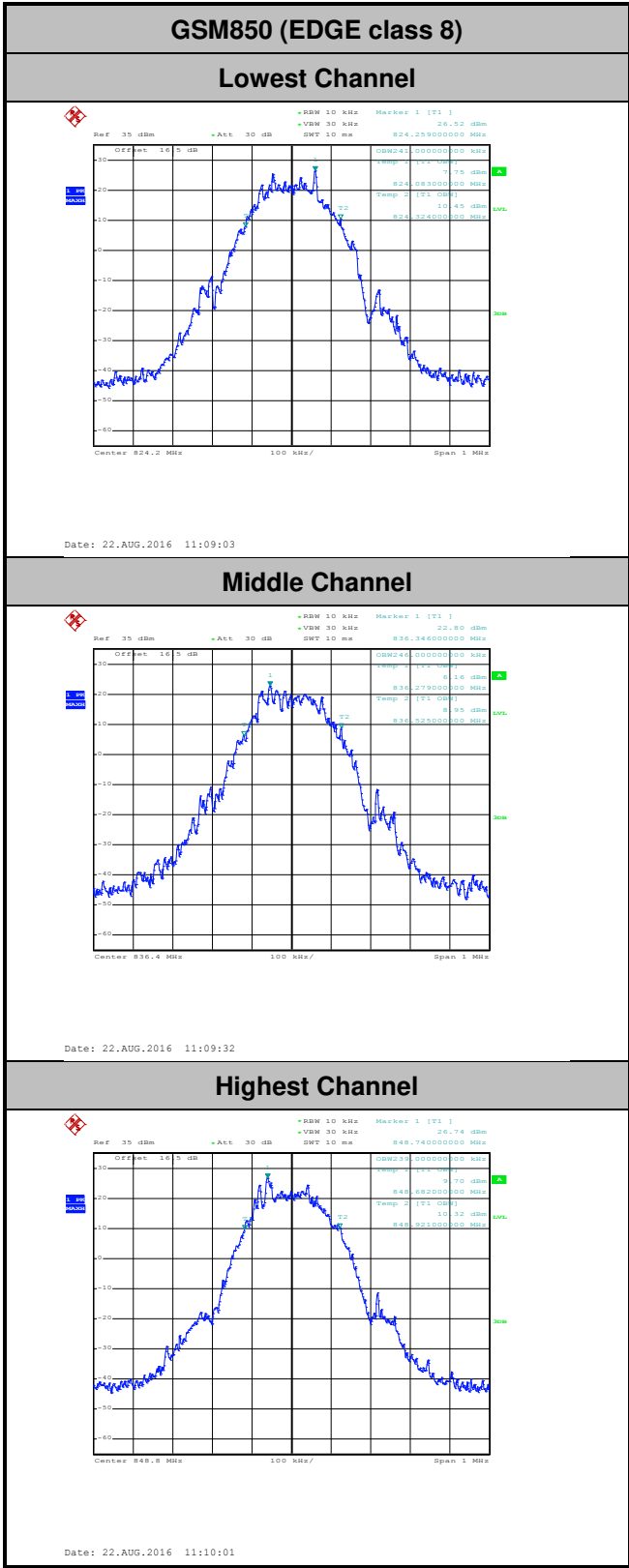



### GSM1900 (GSM)

#### Lowest Channel

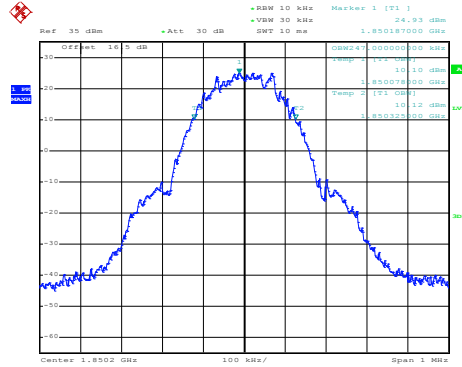

Date: 22.AUG.2016 11:39:48

#### Middle Channel

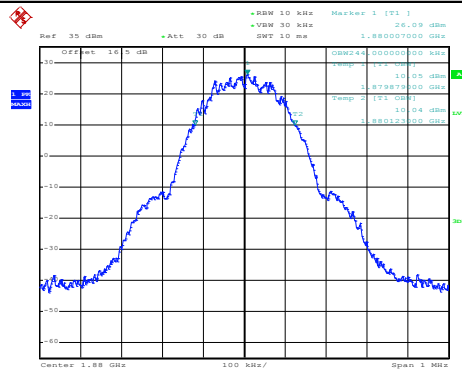

Date: 22.AUG.2016 11:40:16

#### Highest Channel

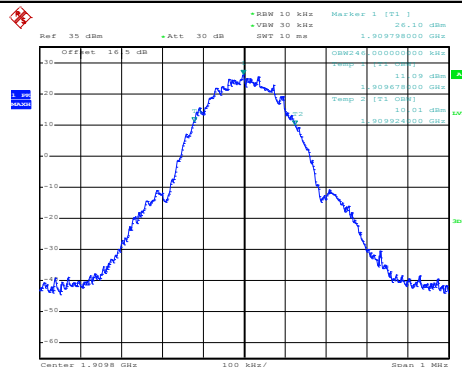

Date: 22.AUG.2016 11:40:44



### GSM1900 (EDGE class 8)

#### Lowest Channel

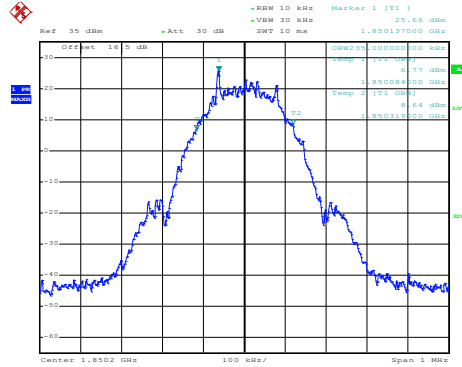

Date: 22.AUG.2016 11:53:50

#### Middle Channel

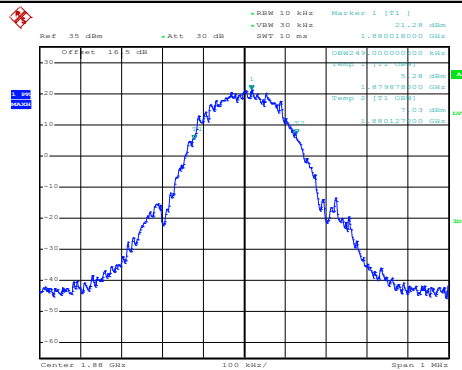

Date: 22.AUG.2016 11:54:18

#### Highest Channel

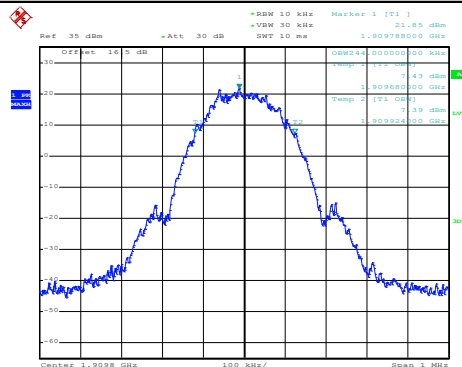

Date: 22.AUG.2016 11:54:46





## Conducted Band Edge

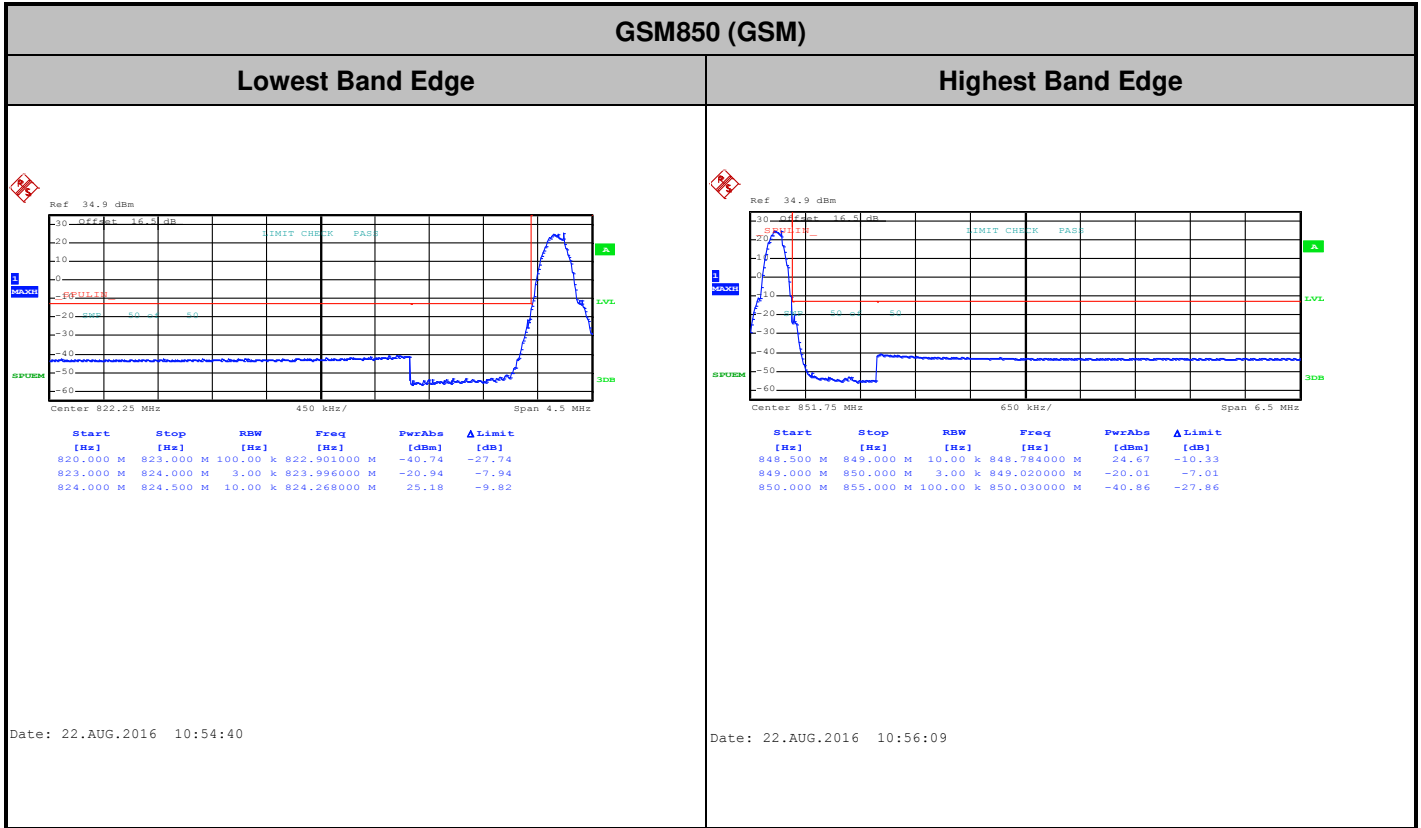



GSM850 (EDGE class 8)

Lowest Band Edge

Highest Band Edge

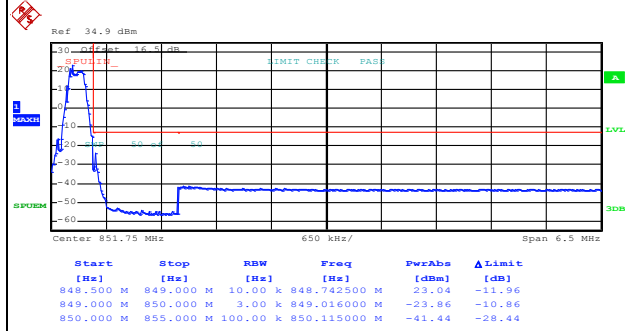
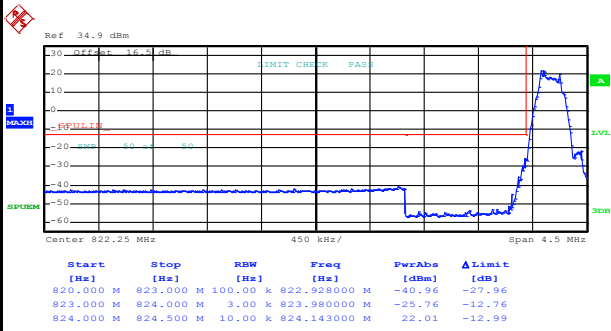

Date: 22.AUG.2016 11:11:33

Date: 22.AUG.2016 11:13:01



GSM1900 (GSM)

Lowest Band Edge

Highest Band Edge

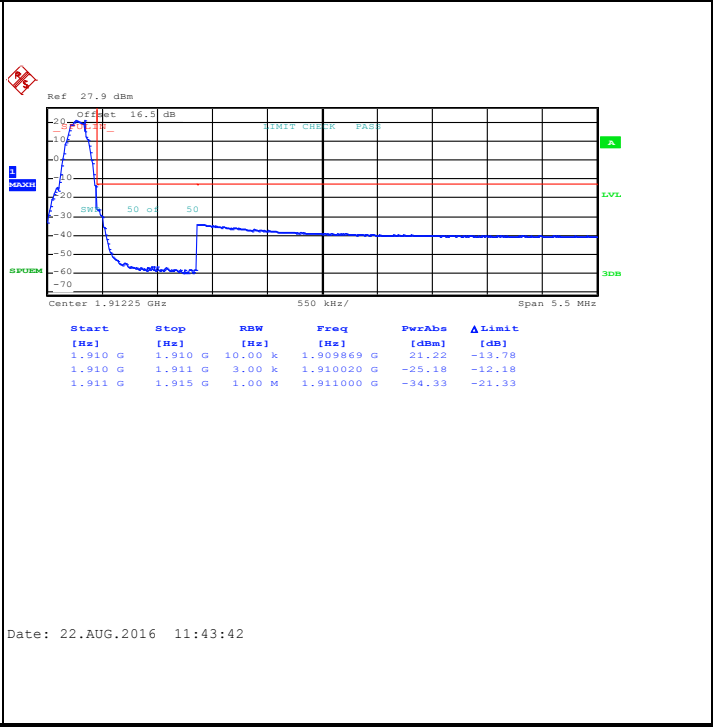
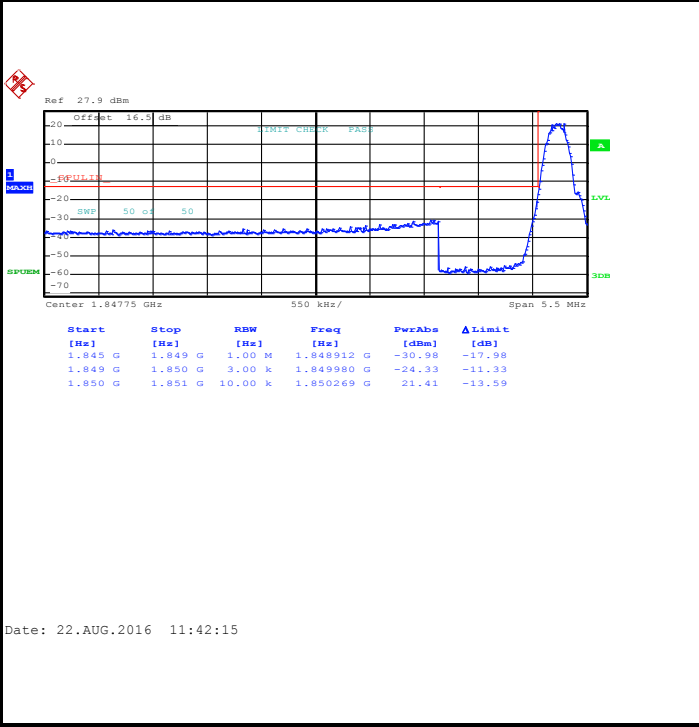



GSM1900 (EDGE class 8)

Lowest Band Edge

Highest Band Edge

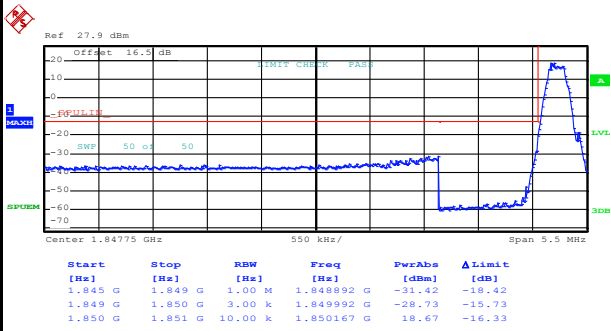

Date: 22.AUG.2016 11:56:15

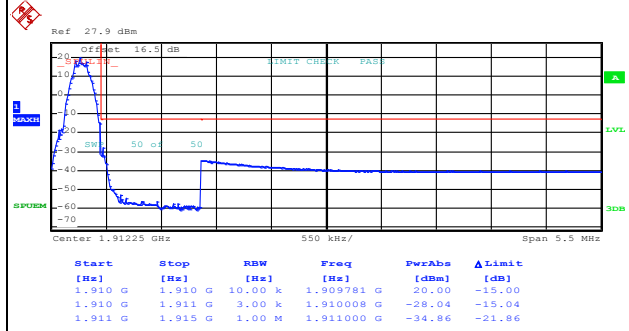

Date: 22.AUG.2016 11:57:42



# Conducted Spurious Emission

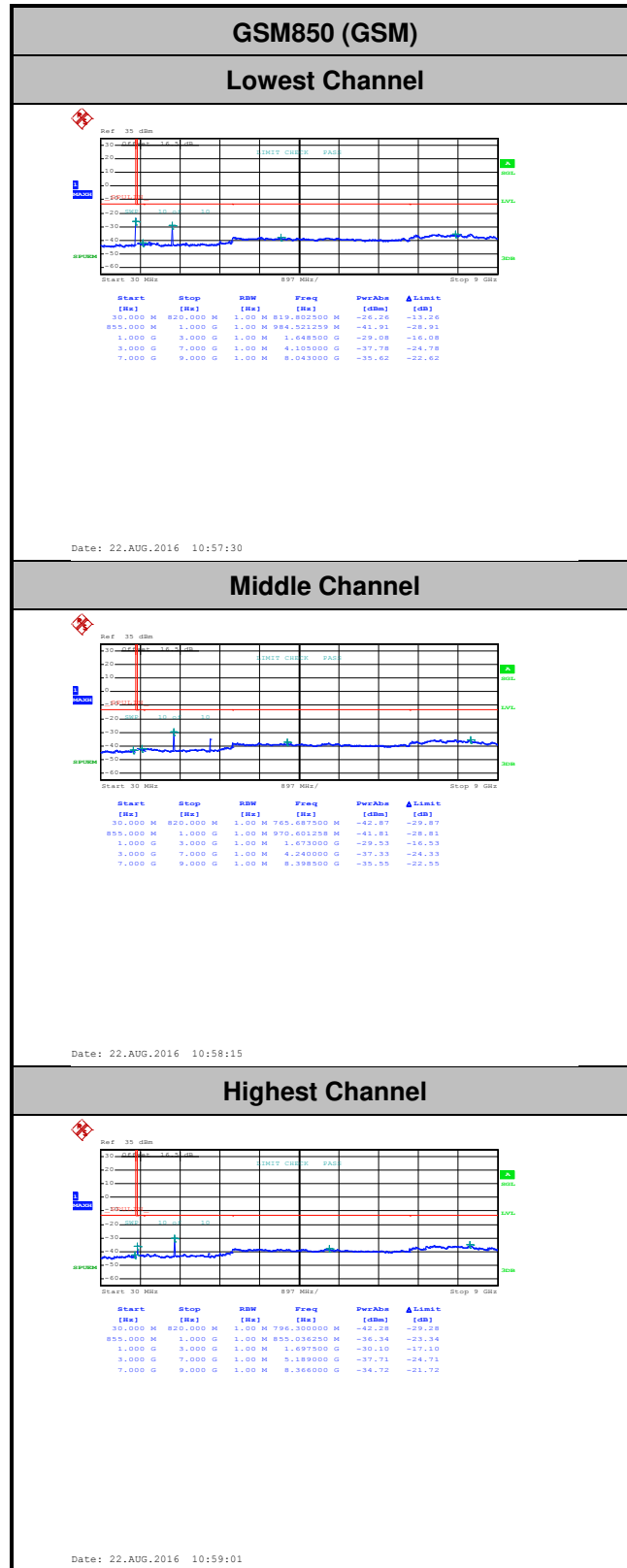

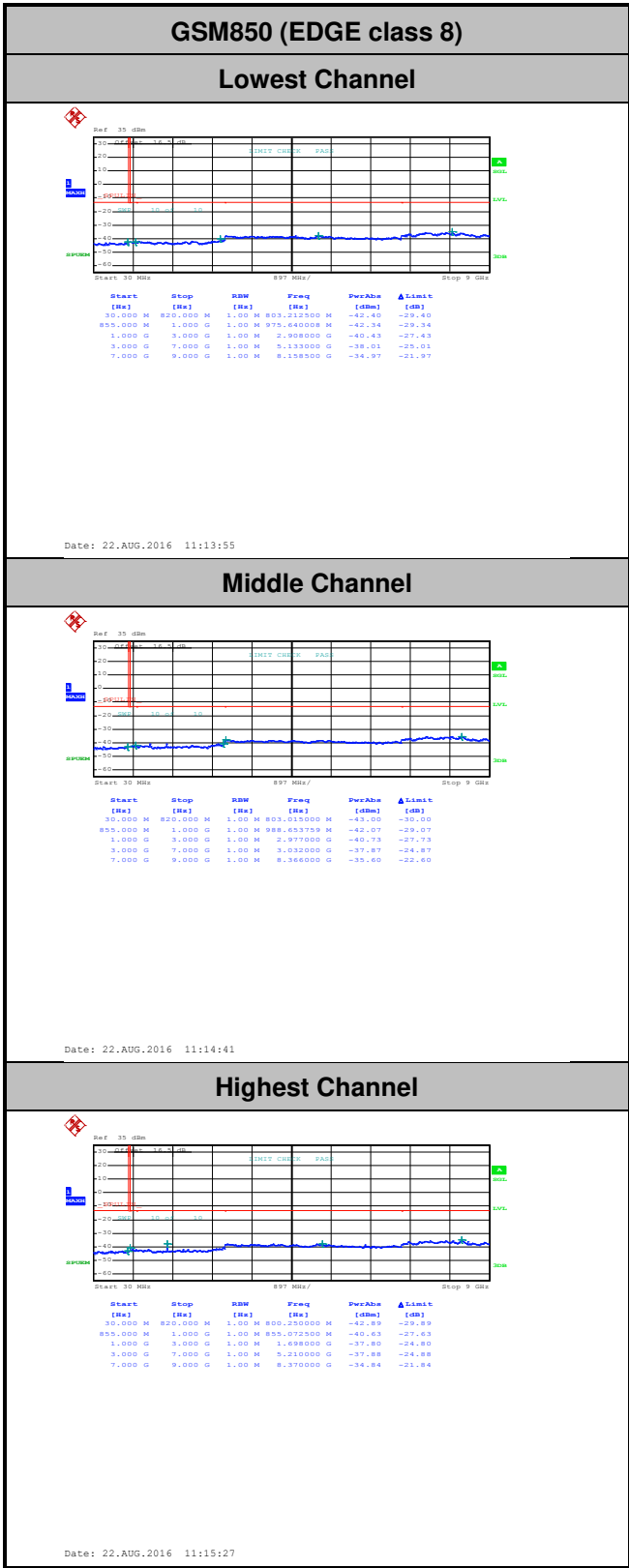



GSM1900 (GSM)

Lowest Channel

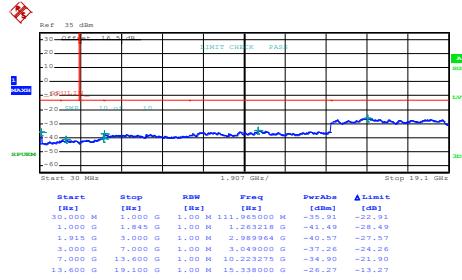

Date: 22.AUG.2016 11:44:40

Middle Channel

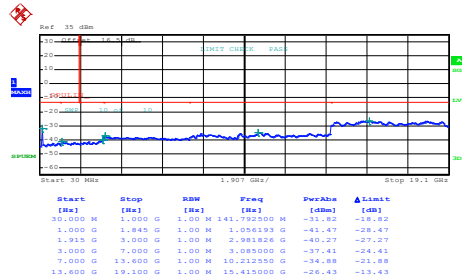

Date: 22.AUG.2016 11:45:26

Highest Channel

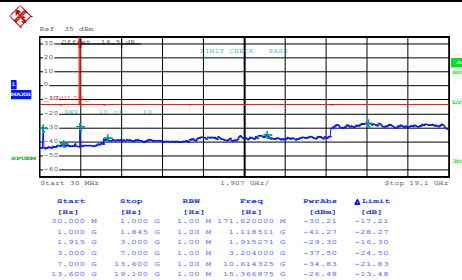

Date: 22.AUG.2016 11:46:11



GSM1900 (EDGE class 8)

Lowest Channel

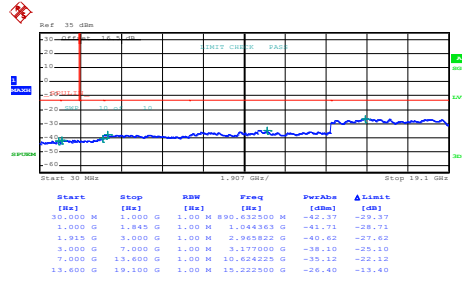

Date: 22.AUG.2016 11:59:20

Middle Channel

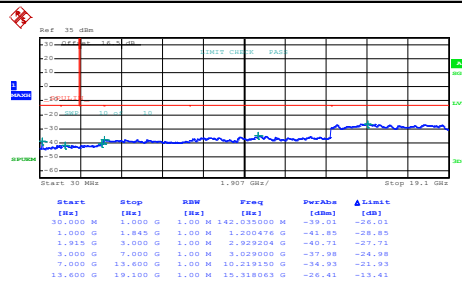

Date: 22.AUG.2016 12:00:06

Highest Channel

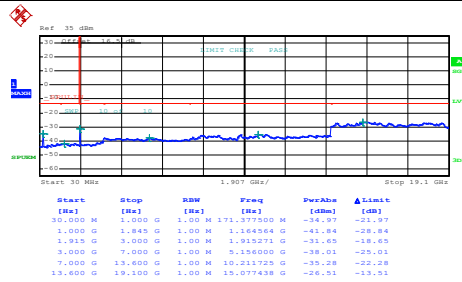

Date: 22.AUG.2016 12:00:53





**Frequency Stability**

Test Conditions	Middle Channel	GSM850 (GSM)	GSM850 (EDGE class 8)	Limit 2.5ppm
Temperature (°C)	Voltage (Volt)	Deviation (ppm)		Result
50	Normal Voltage	0.0097	0.0267	PASS
40	Normal Voltage	0.0121	0.0255	
30	Normal Voltage	0.0085	0.0218	
20(Ref.)	Normal Voltage	0.0061	0.0279	
10	Normal Voltage	0.0049	0.0158	
0	Normal Voltage	0.0073	0.0073	
-10	Normal Voltage	0.0109	0.0061	
-20	Normal Voltage	0.0133	0.0036	
-30	Normal Voltage	0.0158	0.0073	
20	Maximum Voltage	0.0073	0.0267	
20	Normal Voltage	0.0085	0.0243	
20	Battery End Point	0.0085	0.0243	

Test Conditions	Middle Channel	GSM1900 (GSM)	GSM1900 (EDGE class 8)	Limit Note 2.
Temperature (°C)	Voltage (Volt)	Deviation (ppm)		Result
50	Normal Voltage	0.0195	0.0232	PASS
40	Normal Voltage	0.0205	0.0238	
30	Normal Voltage	0.0178	0.0205	
20(Ref.)	Normal Voltage	0.0189	0.0178	
10	Normal Voltage	0.0054	0.0065	
0	Normal Voltage	0.0054	0.0070	
-10	Normal Voltage	0.0070	0.0059	
-20	Normal Voltage	0.0076	0.0054	
-30	Normal Voltage	0.0065	0.0065	
20	Maximum Voltage	0.0173	0.0151	
20	Normal Voltage	0.0178	0.0162	
20	Battery End Point	0.0178	0.0162	

**Note:**

1. Normal Voltage = 3.85V. ; Battery End Point (BEP) = 3.6 V. ; Maximum Voltage =4.4 V
2. The frequency fundamental emissions stay within the authorized frequency block based on the frequency deviation measured is small.



## A2. WCDMA

### Peak-to-Average Ratio

Mode	WCDMA Band V	WCDMA Band II	WCDMA Band IV	Limit: 13dB
Mod.	RMC 12.2Kbps	RMC 12.2Kbps	RMC 12.2Kbps	Result
Lowest CH	2.92	2.92	3.04	<b>PASS</b>
Middle CH	3.12	3.16	3.00	
Highest CH	3.00	2.92	3.24	

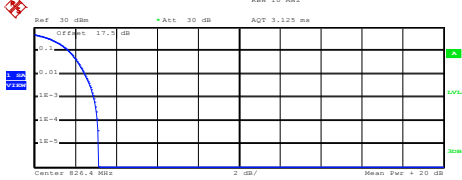
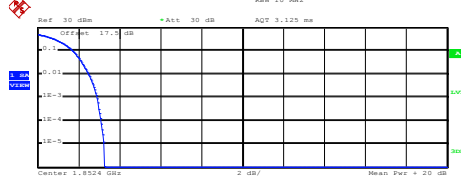
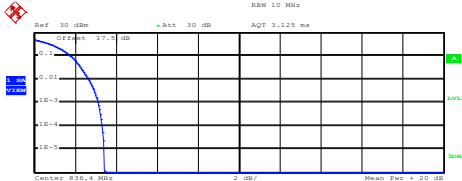
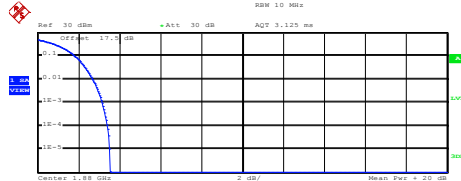
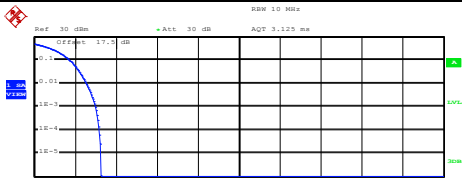
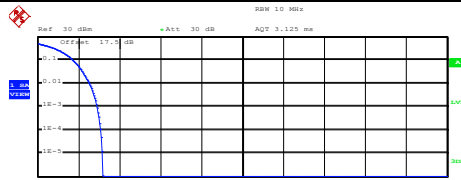

WCDMA Band V (RMC 12.2Kbps)	WCDMA Band II (RMC 12.2Kbps)																
<p style="text-align: center;"><b>Lowest Channel</b></p>  <p>Center 826.4 MHz      2 dB/      Mean Pwr + 20 dB</p> <p>Complementary Cumulative Distribution Function (100000 samples) Trace 1 Mean 24.72 dBm Peak 27.86 dBm Crest 3.13 dB</p> <table border="1"> <tr><td>10 %</td><td>1.68 dB</td></tr> <tr><td>1 %</td><td>2.48 dB</td></tr> <tr><td>.1 %</td><td>2.92 dB</td></tr> <tr><td>.01 %</td><td>3.08 dB</td></tr> </table> <p>Date: 22.AUG.2016 12:51:54</p>	10 %	1.68 dB	1 %	2.48 dB	.1 %	2.92 dB	.01 %	3.08 dB	<p style="text-align: center;"><b>Lowest Channel</b></p>  <p>Center 1.8524 GHz      2 dB/      Mean Pwr + 20 dB</p> <p>Complementary Cumulative Distribution Function (100000 samples) Trace 1 Mean 22.32 dBm Peak 25.60 dBm Crest 3.28 dB</p> <table border="1"> <tr><td>10 %</td><td>1.72 dB</td></tr> <tr><td>1 %</td><td>2.48 dB</td></tr> <tr><td>.1 %</td><td>2.92 dB</td></tr> <tr><td>.01 %</td><td>3.12 dB</td></tr> </table> <p>Date: 22.AUG.2016 12:23:27</p>	10 %	1.72 dB	1 %	2.48 dB	.1 %	2.92 dB	.01 %	3.12 dB
10 %	1.68 dB																
1 %	2.48 dB																
.1 %	2.92 dB																
.01 %	3.08 dB																
10 %	1.72 dB																
1 %	2.48 dB																
.1 %	2.92 dB																
.01 %	3.12 dB																
<p style="text-align: center;"><b>Middle Channel</b></p>  <p>Center 836.4 MHz      2 dB/      Mean Pwr + 20 dB</p> <p>Complementary Cumulative Distribution Function (100000 samples) Trace 1 Mean 24.49 dBm Peak 27.93 dBm Crest 3.44 dB</p> <table border="1"> <tr><td>10 %</td><td>1.80 dB</td></tr> <tr><td>1 %</td><td>2.64 dB</td></tr> <tr><td>.1 %</td><td>3.12 dB</td></tr> <tr><td>.01 %</td><td>3.32 dB</td></tr> </table> <p>Date: 22.AUG.2016 12:52:35</p>	10 %	1.80 dB	1 %	2.64 dB	.1 %	3.12 dB	.01 %	3.32 dB	<p style="text-align: center;"><b>Middle Channel</b></p>  <p>Center 1.88 GHz      2 dB/      Mean Pwr + 20 dB</p> <p>Complementary Cumulative Distribution Function (100000 samples) Trace 1 Mean 22.49 dBm Peak 26.02 dBm Crest 3.53 dB</p> <table border="1"> <tr><td>10 %</td><td>1.84 dB</td></tr> <tr><td>1 %</td><td>2.68 dB</td></tr> <tr><td>.1 %</td><td>3.16 dB</td></tr> <tr><td>.01 %</td><td>3.40 dB</td></tr> </table> <p>Date: 22.AUG.2016 12:24:16</p>	10 %	1.84 dB	1 %	2.68 dB	.1 %	3.16 dB	.01 %	3.40 dB
10 %	1.80 dB																
1 %	2.64 dB																
.1 %	3.12 dB																
.01 %	3.32 dB																
10 %	1.84 dB																
1 %	2.68 dB																
.1 %	3.16 dB																
.01 %	3.40 dB																
<p style="text-align: center;"><b>Highest Channel</b></p>  <p>Center 846.6 MHz      2 dB/      Mean Pwr + 20 dB</p> <p>Complementary Cumulative Distribution Function (100000 samples) Trace 1 Mean 24.02 dBm Peak 27.29 dBm Crest 3.27 dB</p> <table border="1"> <tr><td>10 %</td><td>1.76 dB</td></tr> <tr><td>1 %</td><td>2.56 dB</td></tr> <tr><td>.1 %</td><td>3.00 dB</td></tr> <tr><td>.01 %</td><td>3.20 dB</td></tr> </table> <p>Date: 22.AUG.2016 12:52:57</p>	10 %	1.76 dB	1 %	2.56 dB	.1 %	3.00 dB	.01 %	3.20 dB	<p style="text-align: center;"><b>Highest Channel</b></p>  <p>Center 1.9076 GHz      2 dB/      Mean Pwr + 20 dB</p> <p>Complementary Cumulative Distribution Function (100000 samples) Trace 1 Mean 22.08 dBm Peak 25.25 dBm Crest 3.17 dB</p> <table border="1"> <tr><td>10 %</td><td>1.72 dB</td></tr> <tr><td>1 %</td><td>2.52 dB</td></tr> <tr><td>.1 %</td><td>2.92 dB</td></tr> <tr><td>.01 %</td><td>3.08 dB</td></tr> </table> <p>Date: 22.AUG.2016 12:24:31</p>	10 %	1.72 dB	1 %	2.52 dB	.1 %	2.92 dB	.01 %	3.08 dB
10 %	1.76 dB																
1 %	2.56 dB																
.1 %	3.00 dB																
.01 %	3.20 dB																
10 %	1.72 dB																
1 %	2.52 dB																
.1 %	2.92 dB																
.01 %	3.08 dB																



### WCDMA Band IV (RMC 12.2Kbps)

#### Lowest Channel

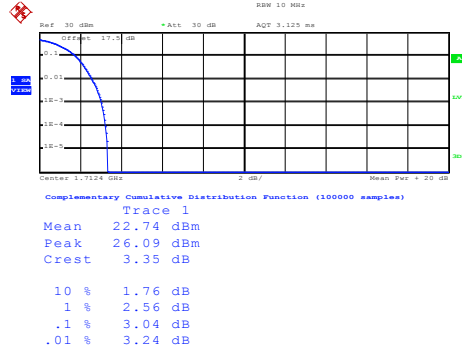

Date: 22.AUG.2016 12:38:36

#### Middle Channel

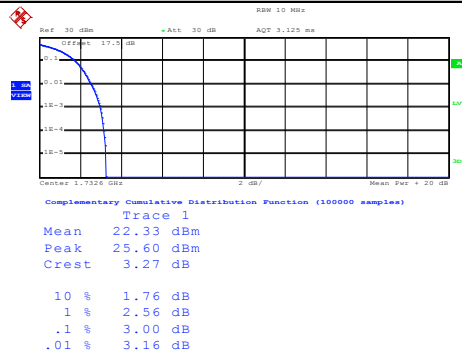

Date: 22.AUG.2016 12:38:55

#### Highest Channel

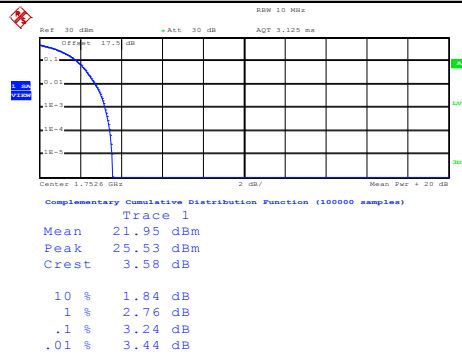

Date: 22.AUG.2016 12:39:30



**26dB Bandwidth**

Mode	WCDMA Band V	WCDMA Band II	WCDMA Band IV
Mod.	RMC 12.2Kbps	RMC 12.2Kbps	RMC 12.2Kbps
Lowest CH	4.68	4.67	4.68
Middle CH	4.67	4.69	4.67
Highest CH	4.69	4.66	4.67

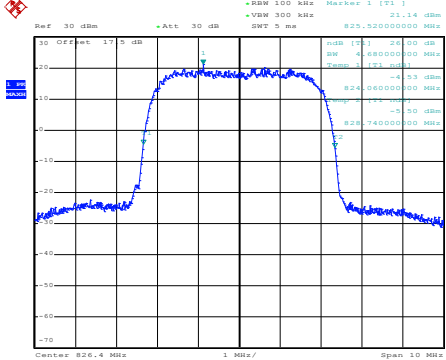
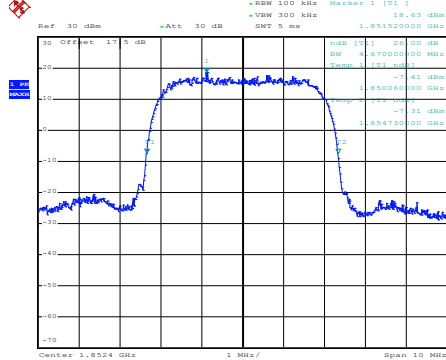
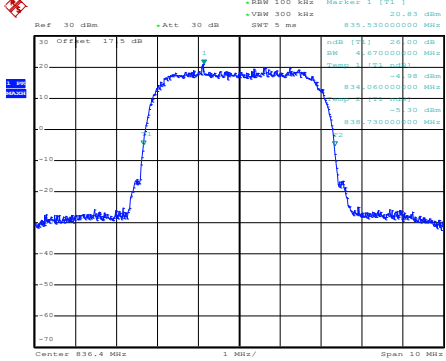
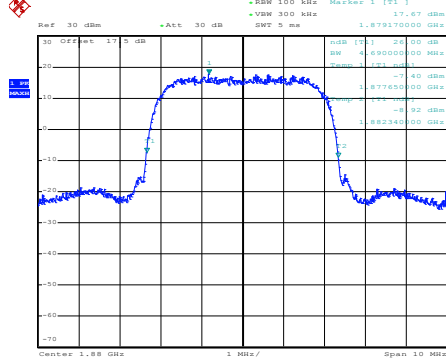
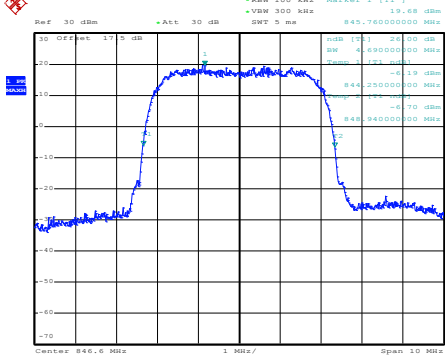
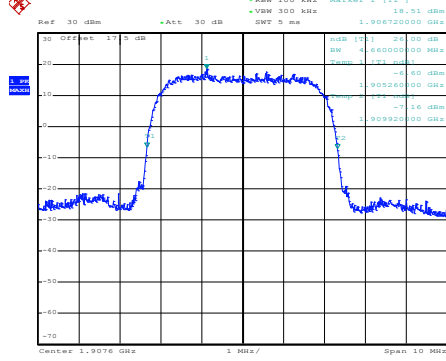

WCDMA Band V (RMC 12.2Kbps)	WCDMA Band II (RMC 12.2Kbps)
<p style="text-align: center;"><b>Lowest Channel</b></p>  <p style="text-align: right;">Date: 22.AUG.2016 12:40:21</p>	<p style="text-align: center;"><b>Lowest Channel</b></p>  <p style="text-align: right;">Date: 22.AUG.2016 12:11:04</p>
<p style="text-align: center;"><b>Middle Channel</b></p>  <p style="text-align: right;">Date: 22.AUG.2016 12:40:49</p>	<p style="text-align: center;"><b>Middle Channel</b></p>  <p style="text-align: right;">Date: 22.AUG.2016 12:11:32</p>
<p style="text-align: center;"><b>Highest Channel</b></p>  <p style="text-align: right;">Date: 22.AUG.2016 12:41:17</p>	<p style="text-align: center;"><b>Highest Channel</b></p>  <p style="text-align: right;">Date: 22.AUG.2016 12:12:00</p>



### WCDMA Band IV (RMC 12.2Kbps)

#### Lowest Channel

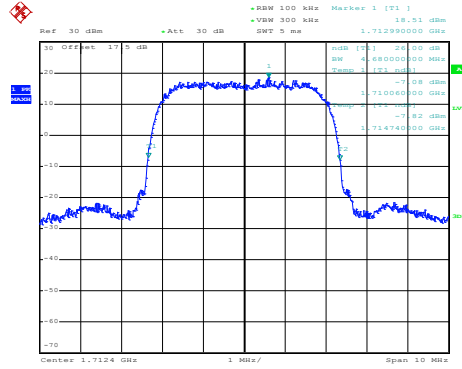

Date: 22.AUG.2016 12:27:05

#### Middle Channel

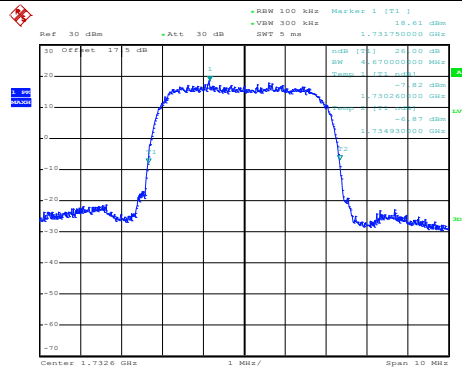

Date: 22.AUG.2016 12:27:33

#### Highest Channel

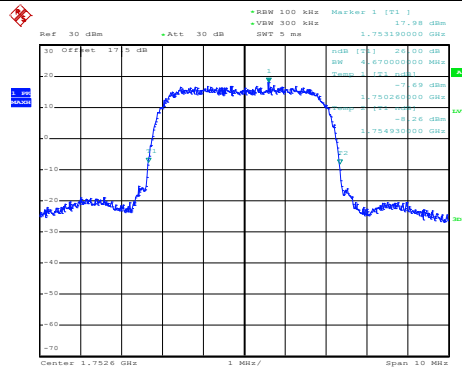

Date: 22.AUG.2016 12:28:01



**Occupied Bandwidth**

Mode	WCDMA Band V	WCDMA Band II	WCDMA Band IV
Mod.	RMC 12.2Kbps	RMC 12.2Kbps	RMC 12.2Kbps
Lowest CH	4.17	4.16	4.16
Middle CH	4.16	4.16	4.16
Highest CH	4.17	4.16	4.16



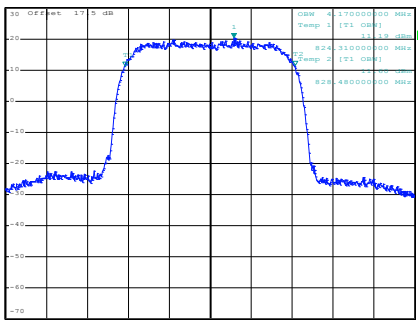
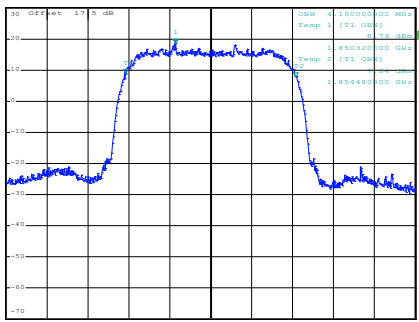
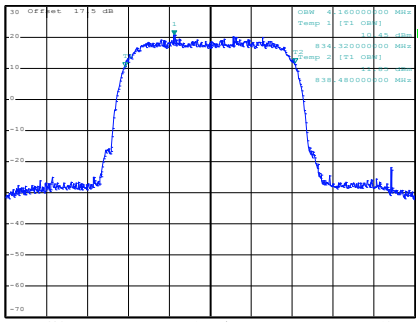
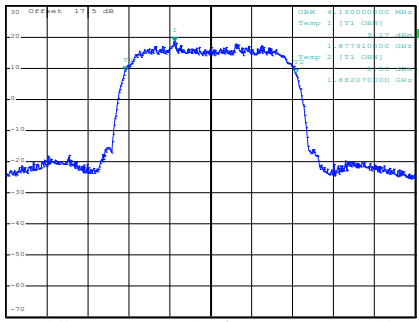
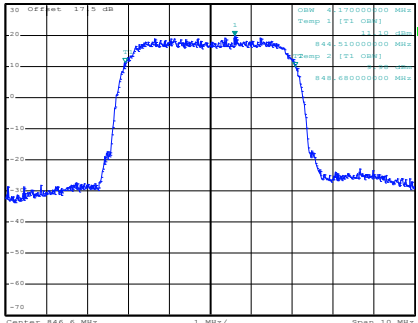
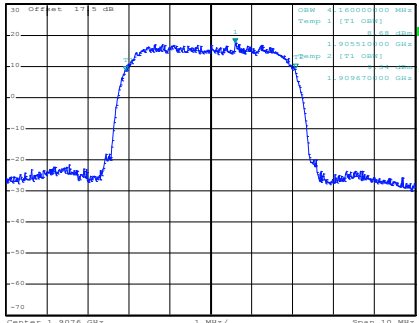

WCDMA Band V (RMC 12.2Kbps)	WCDMA Band II (RMC 12.2Kbps)
<p style="text-align: center;"><b>Lowest Channel</b></p>  <p style="text-align: center;">Date: 22.AUG.2016 12:41:52</p>	<p style="text-align: center;"><b>Lowest Channel</b></p>  <p style="text-align: center;">Date: 22.AUG.2016 12:13:17</p>
<p style="text-align: center;"><b>Middle Channel</b></p>  <p style="text-align: center;">Date: 22.AUG.2016 12:42:20</p>	<p style="text-align: center;"><b>Middle Channel</b></p>  <p style="text-align: center;">Date: 22.AUG.2016 12:13:45</p>
<p style="text-align: center;"><b>Highest Channel</b></p>  <p style="text-align: center;">Date: 22.AUG.2016 12:42:48</p>	<p style="text-align: center;"><b>Highest Channel</b></p>  <p style="text-align: center;">Date: 22.AUG.2016 12:14:13</p>



### WCDMA Band IV (RMC 12.2Kbps)

#### Lowest Channel

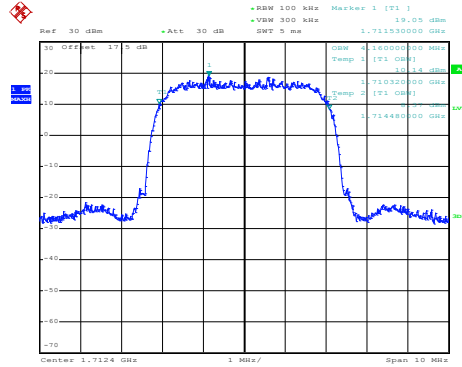

Date: 22.AUG.2016 12:28:50

#### Middle Channel

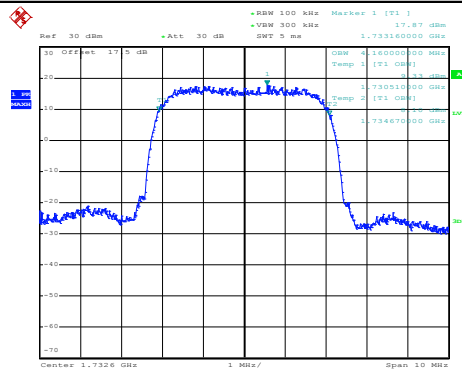

Date: 22.AUG.2016 12:29:18

#### Highest Channel

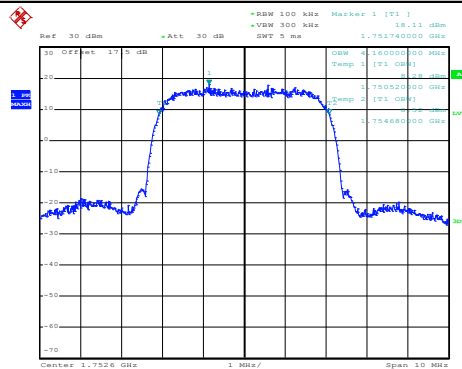

Date: 22.AUG.2016 12:29:46



## Conducted Band Edge

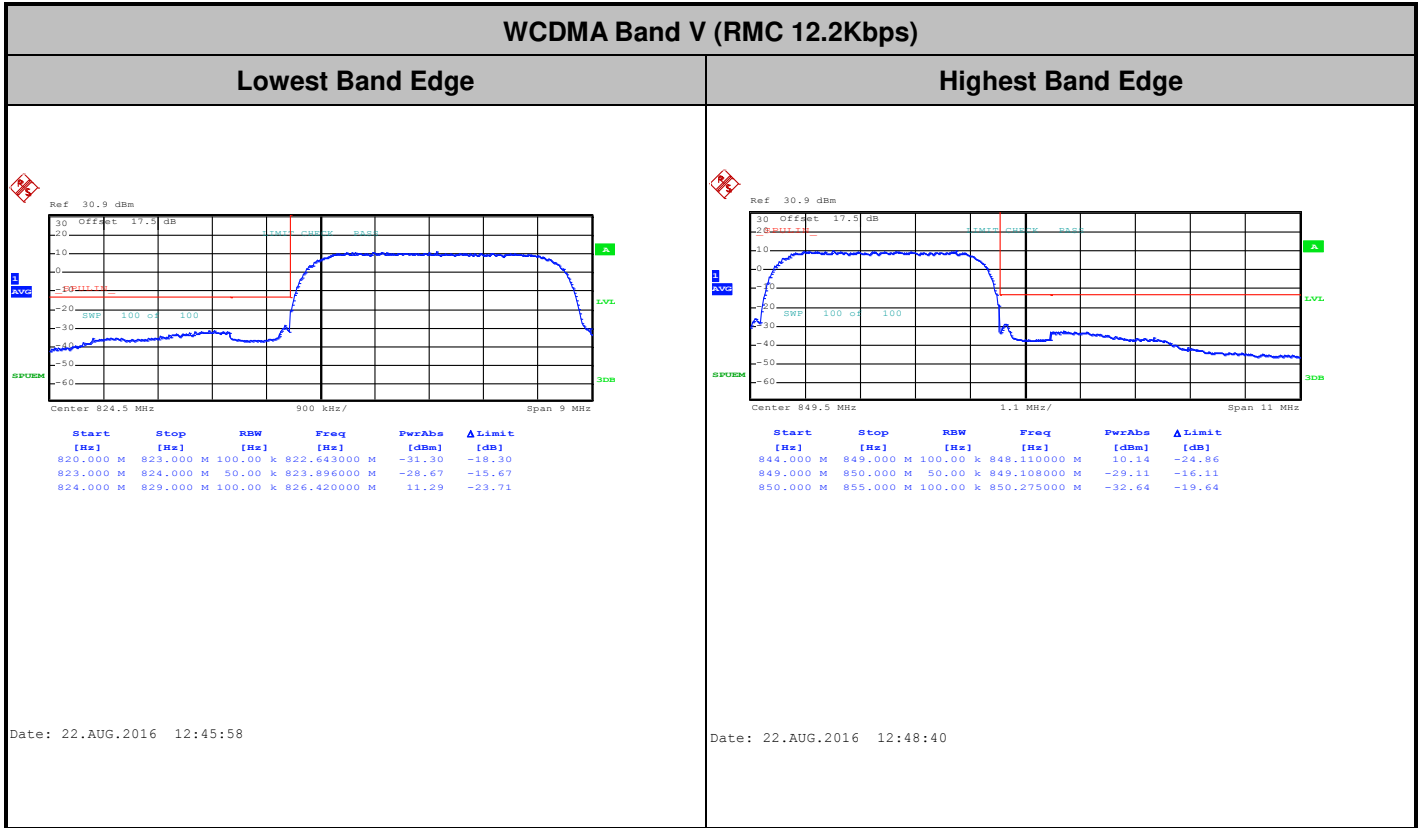



WCDMA Band II (RMC 12.2Kbps)

Lowest Band Edge

Highest Band Edge

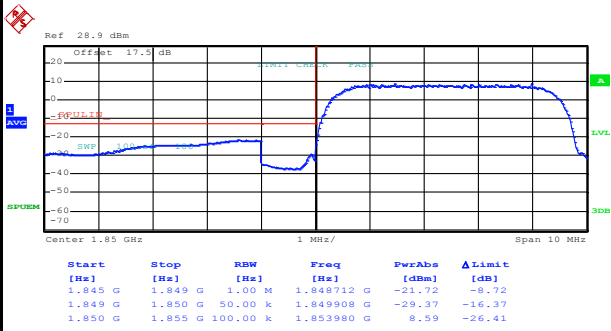

Date: 22.AUG.2016 12:17:31

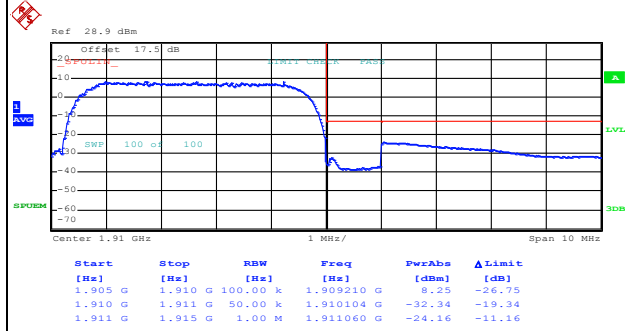

Date: 22.AUG.2016 12:20:13



WCDMA Band IV (RMC 12.2Kbps)

Lowest Band Edge

Highest Band Edge

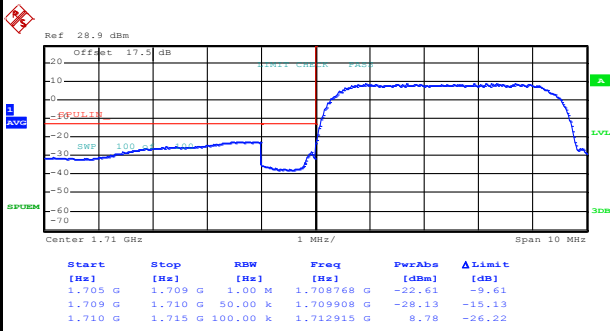

Date: 22.AUG.2016 12:32:35

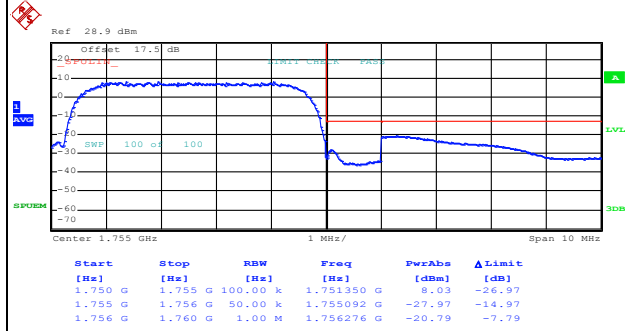

Date: 22.AUG.2016 12:35:18

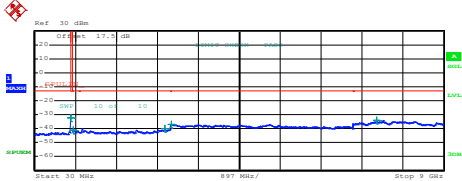
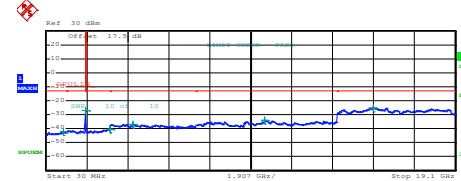
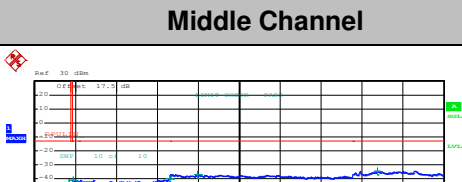
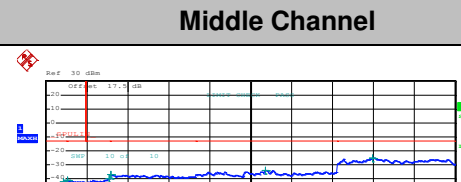
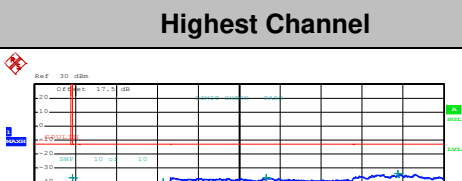
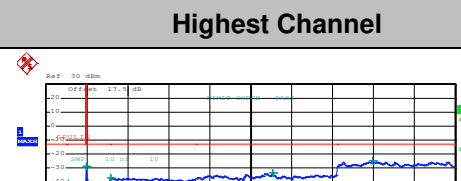

# Conducted Spurious Emission

WCDMA Band V (RMC 12.2Kbps)	WCDMA Band II (RMC 12.2Kbps)																																																																														
Lowest Channel	Lowest Channel																																																																														
 <table border="1" data-bbox="239 660 654 739"> <thead> <tr> <th>Start [Hz]</th> <th>Stop [Hz]</th> <th>RBW [Hz]</th> <th>Freq [Hz]</th> <th>PwrAbs [dBm]</th> <th>ΔLimit [dB]</th> </tr> </thead> <tbody> <tr> <td>30.000 M</td> <td>820.000 M</td> <td>1.00 M</td> <td>816.802000 M</td> <td>-32.35</td> <td>-29.35</td> </tr> <tr> <td>835.000 M</td> <td>1.000 G</td> <td>1.00 M</td> <td>870.623751 M</td> <td>-41.00</td> <td>-28.00</td> </tr> <tr> <td>1.000 G</td> <td>3.000 G</td> <td>1.00 M</td> <td>2.877000 G</td> <td>-39.85</td> <td>-26.85</td> </tr> <tr> <td>3.000 G</td> <td>7.000 G</td> <td>1.00 M</td> <td>3.019000 G</td> <td>-37.08</td> <td>-24.08</td> </tr> <tr> <td>7.000 G</td> <td>9.000 G</td> <td>1.00 M</td> <td>7.527500 G</td> <td>-33.92</td> <td>-20.92</td> </tr> </tbody> </table> <p>Date: 22.AUG.2016 12:49:33</p>	Start [Hz]	Stop [Hz]	RBW [Hz]	Freq [Hz]	PwrAbs [dBm]	ΔLimit [dB]	30.000 M	820.000 M	1.00 M	816.802000 M	-32.35	-29.35	835.000 M	1.000 G	1.00 M	870.623751 M	-41.00	-28.00	1.000 G	3.000 G	1.00 M	2.877000 G	-39.85	-26.85	3.000 G	7.000 G	1.00 M	3.019000 G	-37.08	-24.08	7.000 G	9.000 G	1.00 M	7.527500 G	-33.92	-20.92	 <table border="1" data-bbox="877 660 1292 739"> <thead> <tr> <th>Start [Hz]</th> <th>Stop [Hz]</th> <th>RBW [Hz]</th> <th>Freq [Hz]</th> <th>PwrAbs [dBm]</th> <th>ΔLimit [dB]</th> </tr> </thead> <tbody> <tr> <td>30.000 M</td> <td>1.000 G</td> <td>1.00 M</td> <td>842.617800 M</td> <td>-42.05</td> <td>-29.05</td> </tr> <tr> <td>1.000 G</td> <td>3.000 G</td> <td>1.00 M</td> <td>3.844578 G</td> <td>-26.85</td> <td>-13.85</td> </tr> <tr> <td>3.000 G</td> <td>7.000 G</td> <td>1.00 M</td> <td>2.991049 G</td> <td>-40.34</td> <td>-27.34</td> </tr> <tr> <td>7.000 G</td> <td>13.600 G</td> <td>1.00 M</td> <td>4.088000 G</td> <td>-36.93</td> <td>-23.93</td> </tr> <tr> <td>13.600 G</td> <td>19.100 G</td> <td>1.00 M</td> <td>10.236675 G</td> <td>-34.18</td> <td>-21.18</td> </tr> <tr> <td>19.100 G</td> <td>19.100 G</td> <td>1.00 M</td> <td>15.283000 G</td> <td>-25.04</td> <td>-12.04</td> </tr> </tbody> </table> <p>Date: 22.AUG.2016 12:21:14</p>	Start [Hz]	Stop [Hz]	RBW [Hz]	Freq [Hz]	PwrAbs [dBm]	ΔLimit [dB]	30.000 M	1.000 G	1.00 M	842.617800 M	-42.05	-29.05	1.000 G	3.000 G	1.00 M	3.844578 G	-26.85	-13.85	3.000 G	7.000 G	1.00 M	2.991049 G	-40.34	-27.34	7.000 G	13.600 G	1.00 M	4.088000 G	-36.93	-23.93	13.600 G	19.100 G	1.00 M	10.236675 G	-34.18	-21.18	19.100 G	19.100 G	1.00 M	15.283000 G	-25.04	-12.04
Start [Hz]	Stop [Hz]	RBW [Hz]	Freq [Hz]	PwrAbs [dBm]	ΔLimit [dB]																																																																										
30.000 M	820.000 M	1.00 M	816.802000 M	-32.35	-29.35																																																																										
835.000 M	1.000 G	1.00 M	870.623751 M	-41.00	-28.00																																																																										
1.000 G	3.000 G	1.00 M	2.877000 G	-39.85	-26.85																																																																										
3.000 G	7.000 G	1.00 M	3.019000 G	-37.08	-24.08																																																																										
7.000 G	9.000 G	1.00 M	7.527500 G	-33.92	-20.92																																																																										
Start [Hz]	Stop [Hz]	RBW [Hz]	Freq [Hz]	PwrAbs [dBm]	ΔLimit [dB]																																																																										
30.000 M	1.000 G	1.00 M	842.617800 M	-42.05	-29.05																																																																										
1.000 G	3.000 G	1.00 M	3.844578 G	-26.85	-13.85																																																																										
3.000 G	7.000 G	1.00 M	2.991049 G	-40.34	-27.34																																																																										
7.000 G	13.600 G	1.00 M	4.088000 G	-36.93	-23.93																																																																										
13.600 G	19.100 G	1.00 M	10.236675 G	-34.18	-21.18																																																																										
19.100 G	19.100 G	1.00 M	15.283000 G	-25.04	-12.04																																																																										
<h3>Middle Channel</h3>  <table border="1" data-bbox="239 1131 654 1209"> <thead> <tr> <th>Start [Hz]</th> <th>Stop [Hz]</th> <th>RBW [Hz]</th> <th>Freq [Hz]</th> <th>PwrAbs [dBm]</th> <th>ΔLimit [dB]</th> </tr> </thead> <tbody> <tr> <td>30.000 M</td> <td>820.000 M</td> <td>1.00 M</td> <td>790.770000 M</td> <td>-42.63</td> <td>-29.63</td> </tr> <tr> <td>835.000 M</td> <td>1.000 G</td> <td>1.00 M</td> <td>880.127000 M</td> <td>-43.01</td> <td>-28.01</td> </tr> <tr> <td>1.000 G</td> <td>3.000 G</td> <td>1.00 M</td> <td>2.985000 G</td> <td>-40.04</td> <td>-27.04</td> </tr> <tr> <td>3.000 G</td> <td>7.000 G</td> <td>1.00 M</td> <td>3.195000 G</td> <td>-36.73</td> <td>-23.73</td> </tr> <tr> <td>7.000 G</td> <td>9.000 G</td> <td>1.00 M</td> <td>7.348500 G</td> <td>-34.54</td> <td>-21.54</td> </tr> </tbody> </table> <p>Date: 22.AUG.2016 12:50:19</p>	Start [Hz]	Stop [Hz]	RBW [Hz]	Freq [Hz]	PwrAbs [dBm]	ΔLimit [dB]	30.000 M	820.000 M	1.00 M	790.770000 M	-42.63	-29.63	835.000 M	1.000 G	1.00 M	880.127000 M	-43.01	-28.01	1.000 G	3.000 G	1.00 M	2.985000 G	-40.04	-27.04	3.000 G	7.000 G	1.00 M	3.195000 G	-36.73	-23.73	7.000 G	9.000 G	1.00 M	7.348500 G	-34.54	-21.54	<h3>Middle Channel</h3>  <table border="1" data-bbox="877 1131 1292 1209"> <thead> <tr> <th>Start [Hz]</th> <th>Stop [Hz]</th> <th>RBW [Hz]</th> <th>Freq [Hz]</th> <th>PwrAbs [dBm]</th> <th>ΔLimit [dB]</th> </tr> </thead> <tbody> <tr> <td>30.000 M</td> <td>1.000 G</td> <td>1.00 M</td> <td>821.762500 M</td> <td>-42.10</td> <td>-29.10</td> </tr> <tr> <td>1.000 G</td> <td>3.000 G</td> <td>1.00 M</td> <td>3.02310 G</td> <td>-41.83</td> <td>-28.83</td> </tr> <tr> <td>3.000 G</td> <td>7.000 G</td> <td>1.00 M</td> <td>2.949548 G</td> <td>-39.83</td> <td>-26.83</td> </tr> <tr> <td>7.000 G</td> <td>13.600 G</td> <td>1.00 M</td> <td>3.037000 G</td> <td>-36.98</td> <td>-23.98</td> </tr> <tr> <td>13.600 G</td> <td>19.100 G</td> <td>1.00 M</td> <td>10.248000 G</td> <td>-34.11</td> <td>-21.11</td> </tr> <tr> <td>19.100 G</td> <td>19.100 G</td> <td>1.00 M</td> <td>15.239688 G</td> <td>-25.27</td> <td>-12.27</td> </tr> </tbody> </table> <p>Date: 22.AUG.2016 12:21:59</p>	Start [Hz]	Stop [Hz]	RBW [Hz]	Freq [Hz]	PwrAbs [dBm]	ΔLimit [dB]	30.000 M	1.000 G	1.00 M	821.762500 M	-42.10	-29.10	1.000 G	3.000 G	1.00 M	3.02310 G	-41.83	-28.83	3.000 G	7.000 G	1.00 M	2.949548 G	-39.83	-26.83	7.000 G	13.600 G	1.00 M	3.037000 G	-36.98	-23.98	13.600 G	19.100 G	1.00 M	10.248000 G	-34.11	-21.11	19.100 G	19.100 G	1.00 M	15.239688 G	-25.27	-12.27
Start [Hz]	Stop [Hz]	RBW [Hz]	Freq [Hz]	PwrAbs [dBm]	ΔLimit [dB]																																																																										
30.000 M	820.000 M	1.00 M	790.770000 M	-42.63	-29.63																																																																										
835.000 M	1.000 G	1.00 M	880.127000 M	-43.01	-28.01																																																																										
1.000 G	3.000 G	1.00 M	2.985000 G	-40.04	-27.04																																																																										
3.000 G	7.000 G	1.00 M	3.195000 G	-36.73	-23.73																																																																										
7.000 G	9.000 G	1.00 M	7.348500 G	-34.54	-21.54																																																																										
Start [Hz]	Stop [Hz]	RBW [Hz]	Freq [Hz]	PwrAbs [dBm]	ΔLimit [dB]																																																																										
30.000 M	1.000 G	1.00 M	821.762500 M	-42.10	-29.10																																																																										
1.000 G	3.000 G	1.00 M	3.02310 G	-41.83	-28.83																																																																										
3.000 G	7.000 G	1.00 M	2.949548 G	-39.83	-26.83																																																																										
7.000 G	13.600 G	1.00 M	3.037000 G	-36.98	-23.98																																																																										
13.600 G	19.100 G	1.00 M	10.248000 G	-34.11	-21.11																																																																										
19.100 G	19.100 G	1.00 M	15.239688 G	-25.27	-12.27																																																																										
<h3>Highest Channel</h3>  <table border="1" data-bbox="239 1646 654 1724"> <thead> <tr> <th>Start [Hz]</th> <th>Stop [Hz]</th> <th>RBW [Hz]</th> <th>Freq [Hz]</th> <th>PwrAbs [dBm]</th> <th>ΔLimit [dB]</th> </tr> </thead> <tbody> <tr> <td>30.000 M</td> <td>820.000 M</td> <td>1.00 M</td> <td>612.120000 M</td> <td>-40.52</td> <td>-29.52</td> </tr> <tr> <td>835.000 M</td> <td>1.000 G</td> <td>1.00 M</td> <td>856.015000 M</td> <td>-36.71</td> <td>-23.71</td> </tr> <tr> <td>1.000 G</td> <td>3.000 G</td> <td>1.00 M</td> <td>2.893000 G</td> <td>-40.02</td> <td>-27.02</td> </tr> <tr> <td>3.000 G</td> <td>7.000 G</td> <td>1.00 M</td> <td>3.108000 G</td> <td>-37.18</td> <td>-24.18</td> </tr> <tr> <td>7.000 G</td> <td>9.000 G</td> <td>1.00 M</td> <td>8.004000 G</td> <td>-34.18</td> <td>-21.18</td> </tr> </tbody> </table> <p>Date: 22.AUG.2016 12:51:05</p>	Start [Hz]	Stop [Hz]	RBW [Hz]	Freq [Hz]	PwrAbs [dBm]	ΔLimit [dB]	30.000 M	820.000 M	1.00 M	612.120000 M	-40.52	-29.52	835.000 M	1.000 G	1.00 M	856.015000 M	-36.71	-23.71	1.000 G	3.000 G	1.00 M	2.893000 G	-40.02	-27.02	3.000 G	7.000 G	1.00 M	3.108000 G	-37.18	-24.18	7.000 G	9.000 G	1.00 M	8.004000 G	-34.18	-21.18	<h3>Highest Channel</h3>  <table border="1" data-bbox="877 1646 1292 1724"> <thead> <tr> <th>Start [Hz]</th> <th>Stop [Hz]</th> <th>RBW [Hz]</th> <th>Freq [Hz]</th> <th>PwrAbs [dBm]</th> <th>ΔLimit [dB]</th> </tr> </thead> <tbody> <tr> <td>30.000 M</td> <td>1.000 G</td> <td>1.00 M</td> <td>789.050000 M</td> <td>-41.04</td> <td>-28.04</td> </tr> <tr> <td>1.000 G</td> <td>3.000 G</td> <td>1.00 M</td> <td>3.049855 G</td> <td>-41.01</td> <td>-28.01</td> </tr> <tr> <td>3.000 G</td> <td>7.000 G</td> <td>1.00 M</td> <td>3.035842 G</td> <td>-29.88</td> <td>-16.88</td> </tr> <tr> <td>7.000 G</td> <td>13.600 G</td> <td>1.00 M</td> <td>3.033000 G</td> <td>-37.23</td> <td>-24.23</td> </tr> <tr> <td>13.600 G</td> <td>19.100 G</td> <td>1.00 M</td> <td>10.592000 G</td> <td>-33.70</td> <td>-20.70</td> </tr> <tr> <td>19.100 G</td> <td>19.100 G</td> <td>1.00 M</td> <td>15.245875 G</td> <td>-24.61</td> <td>-11.61</td> </tr> </tbody> </table> <p>Date: 22.AUG.2016 12:22:46</p>	Start [Hz]	Stop [Hz]	RBW [Hz]	Freq [Hz]	PwrAbs [dBm]	ΔLimit [dB]	30.000 M	1.000 G	1.00 M	789.050000 M	-41.04	-28.04	1.000 G	3.000 G	1.00 M	3.049855 G	-41.01	-28.01	3.000 G	7.000 G	1.00 M	3.035842 G	-29.88	-16.88	7.000 G	13.600 G	1.00 M	3.033000 G	-37.23	-24.23	13.600 G	19.100 G	1.00 M	10.592000 G	-33.70	-20.70	19.100 G	19.100 G	1.00 M	15.245875 G	-24.61	-11.61
Start [Hz]	Stop [Hz]	RBW [Hz]	Freq [Hz]	PwrAbs [dBm]	ΔLimit [dB]																																																																										
30.000 M	820.000 M	1.00 M	612.120000 M	-40.52	-29.52																																																																										
835.000 M	1.000 G	1.00 M	856.015000 M	-36.71	-23.71																																																																										
1.000 G	3.000 G	1.00 M	2.893000 G	-40.02	-27.02																																																																										
3.000 G	7.000 G	1.00 M	3.108000 G	-37.18	-24.18																																																																										
7.000 G	9.000 G	1.00 M	8.004000 G	-34.18	-21.18																																																																										
Start [Hz]	Stop [Hz]	RBW [Hz]	Freq [Hz]	PwrAbs [dBm]	ΔLimit [dB]																																																																										
30.000 M	1.000 G	1.00 M	789.050000 M	-41.04	-28.04																																																																										
1.000 G	3.000 G	1.00 M	3.049855 G	-41.01	-28.01																																																																										
3.000 G	7.000 G	1.00 M	3.035842 G	-29.88	-16.88																																																																										
7.000 G	13.600 G	1.00 M	3.033000 G	-37.23	-24.23																																																																										
13.600 G	19.100 G	1.00 M	10.592000 G	-33.70	-20.70																																																																										
19.100 G	19.100 G	1.00 M	15.245875 G	-24.61	-11.61																																																																										



### WCDMA Band IV (RMC 12.2Kbps)

#### Lowest Channel

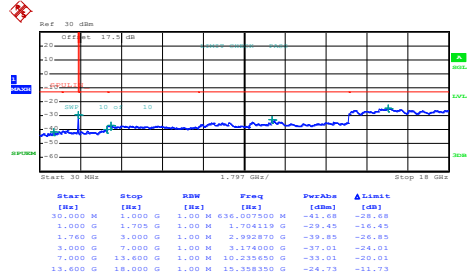

Date: 22.AUG.2016 12:36:20

#### Middle Channel

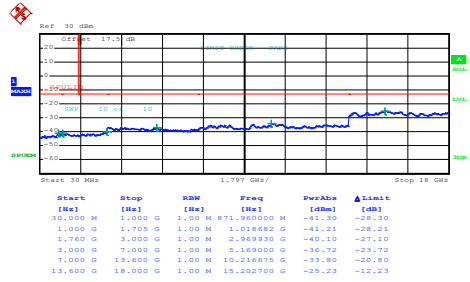

Date: 22.AUG.2016 12:37:06

#### Highest Channel

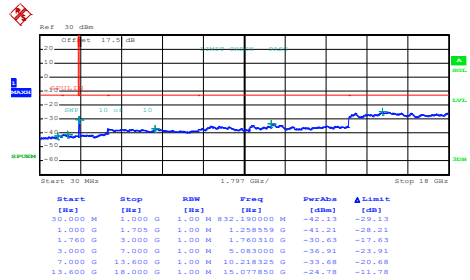

Date: 22.AUG.2016 12:37:52



**Frequency Stability**

Test Conditions	Middle Channel	WCDMA Band V (RMC 12.2Kbps)	Limit 2.5ppm
Temperature (°C)	Voltage (Volt)	Deviation (ppm)	Result
50	Normal Voltage	0.0085	PASS
40	Normal Voltage	0.0097	
30	Normal Voltage	0.0097	
20(Ref.)	Normal Voltage	0.0085	
10	Normal Voltage	0.0085	
0	Normal Voltage	0.0097	
-10	Normal Voltage	0.0097	
-20	Normal Voltage	0.0097	
-30	Normal Voltage	0.0145	
20	Maximum Voltage	0.0085	
20	Normal Voltage	0.0085	
20	Battery End Point	0.0085	

Test Conditions	Middle Channel	WCDMA Band II (RMC 12.2Kbps)	Limit Note 2.
Temperature (°C)	Voltage (Volt)	Deviation (ppm)	Result
50	Normal Voltage	0.0070	PASS
40	Normal Voltage	0.0070	
30	Normal Voltage	0.0070	
20(Ref.)	Normal Voltage	0.0054	
10	Normal Voltage	0.0065	
0	Normal Voltage	0.0065	
-10	Normal Voltage	0.0043	
-20	Normal Voltage	0.0070	
-30	Normal Voltage	0.0065	
20	Maximum Voltage	0.0059	
20	Normal Voltage	0.0059	
20	Battery End Point	0.0070	

**Note:**

1. Normal Voltage = 3.85V. ; Battery End Point (BEP) = 3.6 V. ; Maximum Voltage =4.4 V
2. The frequency fundamental emissions stay within the authorized frequency block based on the frequency deviation measured is small.





Test Conditions	Middle Channel	WCDMA Band IV (RMC 12.2Kbps)	Limit Note 2.
Temperature (°C)	Voltage (Volt)	Deviation (ppm)	Result
50	Normal Voltage	0.0070	PASS
40	Normal Voltage	0.0070	
30	Normal Voltage	0.0070	
20(Ref.)	Normal Voltage	0.0054	
10	Normal Voltage	0.0065	
0	Normal Voltage	0.0065	
-10	Normal Voltage	0.0043	
-20	Normal Voltage	0.0070	
-30	Normal Voltage	0.0065	
20	Maximum Voltage	0.0059	
20	Normal Voltage	0.0059	
20	Battery End Point	0.0070	

**Note:**

1. Normal Voltage = 3.85V. ; Battery End Point (BEP) = 3.6 V. ; Maximum Voltage =4.4 V
2. The frequency fundamental emissions stay within the authorized frequency block based on the frequency deviation measured is small.



## Appendix B. Test Results of Radiated Test

### ERP/EIRP

Channel	Mode	Horizontal		Vertical	
		ERP(dBm)	ERP(W)	ERP(dBm)	ERP(W)
Lowest	GSM850	16.06	0.0404	24.08	0.2559
Middle	GSM	17.99	0.0630	24.13	0.2588
Highest		18.95	0.0785	24.57	0.2864
Lowest	GSM850	11.66	0.0147	18.08	0.0643
Middle	EDGE class 8	11.88	0.0154	18.27	0.0671
Highest		12.70	0.0186	18.70	0.0741
Lowest	WCDMA Band V	9.91	0.0098	17.03	0.0505
Middle	AMR 12.2Kbps	9.88	0.0097	16.93	0.0493
Highest		9.53	0.0090	16.40	0.0437
Limit	ERP < 7W	Result		PASS	

Channel	Mode	Horizontal		Vertical	
		EIRP(dBm)	EIRP(W)	EIRP(dBm)	EIRP(W)
Lowest	GSM1900	25.73	0.3741	27.48	0.5598
Middle	GSM	26.62	0.4592	27.61	0.5768
Highest		26.61	0.4581	27.52	0.5649
Lowest	GSM1900	21.24	0.1330	23.67	0.2328
Middle	EDGE class 8	22.14	0.1637	23.64	0.2312
Highest		22.71	0.1866	24.06	0.2547
Lowest	WCDMA Band II	18.95	0.0785	20.38	0.1091
Middle	AMR 12.2Kbps	20.95	0.1245	20.43	0.1104
Highest		22.00	0.1585	21.24	0.1330
Limit	EIRP < 2W	Result		PASS	

Channel	Mode	Horizontal		Vertical	
		EIRP(dBm)	EIRP(W)	EIRP(dBm)	EIRP(W)
Lowest	WCDMA Band IV	18.77	0.0753	21.19	0.1315
Middle	AMR 12.2Kbps	18.37	0.0687	20.72	0.1180
Highest		17.58	0.0573	20.15	0.1035
Limit	EIRP < 1W	Result		PASS	



**ERP/EIRP**

Channel	Mode	Horizontal		Vertical	
		ERP(dBm)	ERP(W)	ERP(dBm)	ERP(W)
Lowest	GSM850 GSM	9.10	0.0081	21.22	0.1324
Middle		9.63	0.0092	21.39	0.1377
Highest		10.38	0.0109	21.71	0.1483
Lowest	GSM850 EDGE class 8	2.01	0.0016	14.04	0.0254
Middle		3.12	0.0021	14.65	0.0292
Highest		4.38	0.0027	15.13	0.0326
Lowest	WCDMA Band V AMR 12.2Kbps	1.37	0.0014	13.91	0.0246
Middle		0.79	0.0012	14.08	0.0256
Highest		0.16	0.0010	13.66	0.0232
Limit	ERP < 7W	Result		PASS	

Channel	Mode	Horizontal		Vertical	
		EIRP(dBm)	EIRP(W)	EIRP(dBm)	EIRP(W)
Lowest	GSM1900 GSM	24.98	0.3148	27.18	0.5224
Middle		26.44	0.4406	28.34	0.6823
Highest		27.26	0.5321	29.12	0.8166
Lowest	GSM1900 EDGE class 8	21.31	0.1352	23.91	0.2460
Middle		22.99	0.1991	25.01	0.3170
Highest		24.28	0.2679	26.10	0.4074
Lowest	WCDMA Band II AMR 12.2Kbps	19.00	0.0794	21.40	0.1380
Middle		20.84	0.1213	22.44	0.1754
Highest		20.80	0.1202	22.69	0.1858
Limit	EIRP < 2W	Result		PASS	

Channel	Mode	Horizontal		Vertical	
		EIRP(dBm)	EIRP(W)	EIRP(dBm)	EIRP(W)
Lowest	WCDMA Band IV AMR 12.2Kbps	17.50	0.0562	20.12	0.1028
Middle		17.41	0.0551	20.39	0.1094
Highest		17.56	0.0570	20.64	0.1159
Limit	EIRP < 1W	Result		PASS	



Radiated Spurious Emission

<Ant. 1>

Table with columns: Channel, Frequency (MHz), ERP (dBm), Limit (dBm), Over Limit (dB), SPA Reading (dBm), S.G. Power (dBm), TX Cable loss (dB), TX Antenna Gain (dBi), Polarization (H/V). Rows are grouped by 'Lowest', 'Middle', and 'Highest' frequency bands.

Remark: Spurious emissions within 30-1000MHz were found more than 20dB below limit line.



GSM850 (EDGE class 8)									
Channel	Frequency ( MHz )	ERP ( dBm )	Limit ( dBm )	Over Limit ( dB )	SPA Reading (dBm)	S.G. Power ( dBm )	TX Cable loss ( dB )	TX Antenna Gain (dBi)	Polarization (H/V)
Lowest	1648	-54.59	-13	-41.59	-67.76	-56.35	0.98	4.89	H
	2472	-19.11	-13	-6.11	-35.46	-20.99	1.28	5.32	H
	3296	-50.10	-13	-37.10	-69.78	-53.51	1.54	7.10	H
	4120	-49.12	-13	-36.12	-70.58	-53.76	1.83	8.62	H
									H
									H
	1648	-57.28	-13	-44.28	-70.45	-59.04	0.98	4.89	V
	2472	-23.88	-13	-10.88	-40.23	-25.76	1.28	5.32	V
	3296	-54.18	-13	-41.18	-73.86	-57.59	1.54	7.10	V
	4120	-51.37	-13	-38.37	-72.83	-56.01	1.83	8.62	V
								V	
								V	
Middle	1672	-55.32	-13	-42.32	-68.56	-57	0.99	4.82	H
	2512	-16.85	-13	-3.85	-33.37	-18.82	1.29	5.41	H
	3344	-49.51	-13	-36.51	-69.32	-53.12	1.56	7.31	H
	4184	-55.44	-13	-42.44	-77.12	-60.06	1.87	8.64	H
									H
									H
	1672	-55.09	-13	-42.09	-68.33	-56.77	0.99	4.82	V
	2512	-19.70	-13	-6.70	-36.22	-21.67	1.29	5.41	V
	3344	-50.70	-13	-37.70	-70.51	-54.31	1.56	7.31	V
	4184	-54.60	-13	-41.60	-76.28	-59.22	1.87	8.64	V
								V	
								V	
Highest	1696	-49.18	-13	-36.18	-62.48	-50.78	1.00	4.75	H
	2544	-16.04	-13	-3.04	-32.73	-18.02	1.30	5.44	H
	3392	-51.14	-13	-38.14	-71.09	-54.94	1.57	7.52	H
	4248	-47.07	-13	-34.07	-69.01	-51.67	1.90	8.65	H
									H
									H
	1696	-48.54	-13	-35.54	-61.84	-50.14	1.00	4.75	V
	2544	-18.31	-13	-5.31	-35	-20.29	1.30	5.44	V
	3392	-57.38	-13	-44.38	-77.33	-61.18	1.57	7.52	V
	4248	-49.48	-13	-36.48	-71.42	-54.08	1.90	8.65	V
								V	
								V	

Remark: Spurious emissions within 30-1000MHz were found more than 20dB below limit line.



GSM1900 (GSM)									
Channel	Frequency ( MHz )	EIRP ( dBm )	Limit ( dBm )	Over Limit ( dB )	SPA Reading (dBm)	S.G. Power ( dBm )	TX Cable loss ( dB )	TX Antenna Gain (dBi)	Polarization (H/V)
Lowest	3700	-39.98	-13	-26.98	-60.49	-46.55	1.67	8.24	H
	5551	-53.51	-13	-40.51	-80.15	-60.58	2.65	9.72	H
	7401	-47.00	-13	-34.00	-80.23	-56.14	2.46	11.60	H
									H
									H
									H
	3700	-40.41	-13	-27.41	-60.92	-46.98	1.67	8.24	V
	5551	-53.34	-13	-40.34	-79.98	-60.41	2.65	9.72	V
	7401	-46.99	-13	-33.99	-80.22	-56.13	2.46	11.60	V
									V
Middle	3763	-36.79	-13	-23.79	-57.39	-43.42	1.69	8.32	H
	5639	-48.21	-13	-35.21	-75.09	-55.26	2.71	9.76	H
	7520	-46.51	-13	-33.51	-79.95	-55.9	2.42	11.81	H
									H
									H
									H
	3763	-44.99	-13	-31.99	-65.59	-51.62	1.69	8.32	V
	5639	-51.91	-13	-38.91	-78.79	-58.96	2.71	9.76	V
	7520	-46.95	-13	-33.95	-80.39	-56.34	2.42	11.81	V
									V
Highest	3819	-39.13	-13	-26.13	-59.81	-45.81	1.70	8.38	H
	5730	-51.74	-13	-38.74	-78.89	-58.77	2.76	9.79	H
	7639	-46.38	-13	-33.38	-80.01	-55.88	2.38	11.88	H
									H
									H
									H
	3819	-46.08	-13	-33.08	-66.76	-52.76	1.70	8.38	V
	5730	-53.08	-13	-40.08	-80.23	-60.11	2.76	9.79	V
	7639	-46.31	-13	-33.31	-79.94	-55.81	2.38	11.88	V
									V

Remark: Spurious emissions within 30-1000MHz were found more than 20dB below limit line.



GSM1900 (EDGE class 8)									
Channel	Frequency ( MHz )	EIRP ( dBm )	Limit ( dBm )	Over Limit ( dB )	SPA Reading (dBm)	S.G. Power ( dBm )	TX Cable loss ( dB )	TX Antenna Gain (dBi)	Polarization (H/V)
Lowest	3700	-44.71	-13	-31.71	-65.22	-51.28	1.67	8.24	H
	5551	-53.77	-13	-40.77	-80.41	-60.84	2.65	9.72	H
	7401	-47.07	-13	-34.07	-80.3	-56.21	2.46	11.60	H
									H
									H
									H
	3700	-47.87	-13	-34.87	-68.38	-54.44	1.67	8.24	V
	5551	-53.72	-13	-40.72	-80.36	-60.79	2.65	9.72	V
	7401	-46.89	-13	-33.89	-80.12	-56.03	2.46	11.60	V
									V
									V
									V
Middle	3763	-48.24	-13	-35.24	-68.84	-54.87	1.69	8.32	H
	5639	-53.41	-13	-40.41	-80.29	-60.46	2.71	9.76	H
	7520	-46.94	-13	-33.94	-80.38	-56.33	2.42	11.81	H
									H
									H
									H
	3763	-50.09	-13	-37.09	-70.69	-56.72	1.69	8.32	V
	5639	-53.50	-13	-40.50	-80.38	-60.55	2.71	9.76	V
	7520	-46.82	-13	-33.82	-80.26	-56.21	2.42	11.81	V
									V
									V
									V
Highest	3819	-47.74	-13	-34.74	-68.42	-54.42	1.70	8.38	H
	5730	-52.67	-13	-39.67	-79.82	-59.7	2.76	9.79	H
	7639	-46.40	-13	-33.40	-80.03	-55.9	2.38	11.88	H
									H
									H
									H
	3819	-52.57	-13	-39.57	-73.25	-59.25	1.70	8.38	V
	5730	-52.75	-13	-39.75	-79.9	-59.78	2.76	9.79	V
	7639	-46.46	-13	-33.46	-80.09	-55.96	2.38	11.88	V
									V
									V
									V

Remark: Spurious emissions within 30-1000MHz were found more than 20dB below limit line.



WCDMA Band V(RMC 12.2Kbps)									
Channel	Frequency ( MHz )	ERP ( dBm )	Limit ( dBm )	Over Limit ( dB )	SPA Reading (dBm)	S.G. Power ( dBm )	TX Cable loss ( dB )	TX Antenna Gain (dBi)	Polarization (H/V)
Lowest	1648	-62.42	-13	-49.42	-75.59	-64.18	0.98	4.89	H
	2480	-32.29	-13	-19.29	-48.64	-34.2	1.28	5.34	H
	3306	-58.62	-13	-45.62	-78.34	-62.07	1.54	7.15	H
	4128	-55.18	-13	-42.18	-76.65	-59.82	1.83	8.63	H
									H
									H
	1648	-63.39	-13	-50.39	-76.56	-65.15	0.98	4.89	V
	2480	-35.27	-13	-22.27	-51.62	-37.18	1.28	5.34	V
	3306	-58.60	-13	-45.60	-78.32	-62.05	1.54	7.15	V
	4128	-56.03	-13	-43.03	-77.5	-60.67	1.83	8.63	V
									V
									V
Middle	1673	-62.26	-13	-49.26	-75.5	-63.94	0.99	4.82	H
	2509	-32.85	-13	-19.85	-49.37	-34.81	1.29	5.41	H
	3346	-58.76	-13	-45.76	-78.57	-62.38	1.56	7.32	H
	4182	-55.41	-13	-42.41	-77.09	-60.03	1.87	8.64	H
									H
									H
	1673	-62.30	-13	-49.30	-75.54	-63.98	0.99	4.82	V
	2509	-34.22	-13	-21.22	-50.74	-36.18	1.29	5.41	V
	3346	-58.84	-13	-45.84	-78.65	-62.46	1.56	7.32	V
	4182	-55.93	-13	-42.93	-77.61	-60.55	1.87	8.64	V
									V
									V
Highest	1696	-60.34	-13	-47.34	-73.64	-61.94	1.00	4.75	H
	2536	-32.69	-13	-19.69	-49.29	-34.67	1.30	5.43	H
	3386	-58.56	-13	-45.56	-78.47	-62.34	1.57	7.50	H
	4232	-55.20	-13	-42.20	-77.08	-59.8	1.89	8.65	H
									H
									H
	1696	-61.02	-13	-48.02	-74.32	-62.62	1.00	4.75	V
	2536	-34.07	-13	-21.07	-50.67	-36.05	1.30	5.43	V
	3386	-58.68	-13	-45.68	-78.59	-62.46	1.57	7.50	V
	4232	-55.79	-13	-42.79	-77.67	-60.39	1.89	8.65	V
									V
									V

Remark: Spurious emissions within 30-1000MHz were found more than 20dB below limit line.





WCDMA Band II(RMC 12.2Kbps)									
Channel	Frequency ( MHz )	EIRP ( dBm )	Limit ( dBm )	Over Limit ( dB )	SPA Reading (dBm)	S.G. Power ( dBm )	TX Cable loss ( dB )	TX Antenna Gain (dBi)	Polarization (H/V)
Lowest	3707	-55.75	-13	-42.75	-76.26	-62.33	1.67	8.25	H
	5557	-53.04	-13	-40.04	-79.67	-60.1	2.66	9.72	H
	7410	-47.16	-13	-34.16	-80.39	-56.32	2.46	11.62	H
									H
									H
									H
	3707	-56.16	-13	-43.16	-76.67	-62.74	1.67	8.25	V
	5557	-52.99	-13	-39.99	-79.62	-60.05	2.66	9.72	V
	7410	-46.97	-13	-33.97	-80.2	-56.13	2.46	11.62	V
									V
Middle	3763	-57.37	-13	-44.37	-77.97	-64	1.69	8.32	H
	5639	-52.74	-13	-39.74	-79.62	-59.79	2.71	9.76	H
	7520	-46.75	-13	-33.75	-80.19	-56.14	2.42	11.81	H
									H
									H
									H
	3763	-56.66	-13	-43.66	-77.26	-63.29	1.69	8.32	V
	5639	-52.56	-13	-39.56	-79.44	-59.61	2.71	9.76	V
	7520	-46.88	-13	-33.88	-80.32	-56.27	2.42	11.81	V
									V
Highest	3815	-57.36	-13	-44.36	-78.03	-64.03	1.70	8.38	H
	5723	-51.86	-13	-38.86	-79.01	-58.9	2.75	9.79	H
	7630	-46.03	-13	-33.03	-79.63	-55.52	2.39	11.88	H
									H
									H
									H
	3815	-56.87	-13	-43.87	-77.54	-63.54	1.70	8.38	V
	5723	-51.97	-13	-38.97	-79.12	-59.01	2.75	9.79	V
	7630	-45.97	-13	-32.97	-79.57	-55.46	2.39	11.88	V
									V

Remark: Spurious emissions within 30-1000MHz were found more than 20dB below limit line.



WCDMA Band IV(RMC 12.2Kbps)									
Channel	Frequency ( MHz )	EIRP ( dBm )	Limit ( dBm )	Over Limit ( dB )	SPA Reading (dBm)	S.G. Power ( dBm )	TX Cable loss ( dB )	TX Antenna Gain (dBi)	Polarization (H/V)
Lowest	3427	-54.52	-13	-41.52	-76.57	-60.62	1.58	7.68	H
	5137	-54.07	-13	-41.07	-79.62	-61.35	2.42	9.70	H
	6850	-48.17	-13	-35.17	-80.15	-56.15	2.64	10.62	H
									H
									H
									H
	3427	-58.17	-13	-45.17	-78.22	-64.27	1.58	7.68	V
	5137	-53.89	-13	-40.89	-79.44	-61.17	2.42	9.70	V
	6850	-48.46	-13	-35.46	-80.44	-56.44	2.64	10.62	V
									V
Middle	3465	-57.36	-13	-44.36	-77.51	-63.61	1.59	7.85	H
	5198	-54.21	-13	-41.21	-79.93	-61.46	2.45	9.70	H
	6930	-47.54	-13	-34.54	-79.76	-55.64	2.61	10.72	H
									H
									H
									H
	3465	-58.20	-13	-45.20	-78.35	-64.45	1.59	7.85	V
	5198	-54.31	-13	-41.31	-80.03	-61.56	2.45	9.70	V
	6930	-47.87	-13	-34.87	-80.09	-55.97	2.61	10.72	V
									V
Highest	3505	-58.30	-13	-45.30	-78.53	-64.7	1.61	8.01	H
	5258	-54.08	-13	-41.08	-79.92	-61.29	2.49	9.70	H
	7010	-47.55	-13	-34.55	-80.03	-55.78	2.59	10.82	H
									H
									H
									H
	3505	-58.40	-13	-45.40	-78.63	-64.8	1.61	8.01	V
	5258	-53.77	-13	-40.77	-79.61	-60.98	2.49	9.70	V
	7010	-47.66	-13	-34.66	-80.14	-55.89	2.59	10.82	V
									V

Remark: Spurious emissions within 30-1000MHz were found more than 20dB below limit line.



<Ant. 2>

GSM850 (GSM)									
Channel	Frequency ( MHz )	ERP ( dBm )	Limit ( dBm )	Over Limit ( dB )	SPA Reading (dBm)	S.G. Power ( dBm )	TX Cable loss ( dB )	TX Antenna Gain (dBi)	Polarization (H/V)
Lowest	1648	-43.57	-13	-30.57	-57.13	-45.33	0.98	4.89	H
	2472	-23.81	-13	-10.81	-40.31	-25.69	1.28	5.32	H
	3296	-54.71	-13	-41.71	-73.93	-58.12	1.54	7.10	H
	4120	-45.33	-13	-32.33	-67.03	-49.97	1.83	8.62	H
									H
									H
	1648	-49.91	-13	-36.91	-63.11	-51.67	0.98	4.89	V
	2472	-30.58	-13	-17.58	-46.68	-32.46	1.28	5.32	V
	3296	-54.38	-13	-41.38	-74.03	-57.79	1.54	7.10	V
	4120	-52.69	-13	-39.69	-74.34	-57.33	1.83	8.62	V
								V	
								V	
Middle	1672	-43.38	-13	-30.38	-57.19	-45.06	0.99	4.82	H
	2512	-24.22	-13	-11.22	-40.62	-26.19	1.29	5.41	H
	3344	-53.82	-13	-40.82	-73.17	-57.43	1.56	7.31	H
	4184	-48.19	-13	-35.19	-69.96	-52.81	1.87	8.64	H
									H
									H
	1672	-47.94	-13	-34.94	-60.98	-49.62	0.99	4.82	V
	2512	-27.89	-13	-14.89	-44.22	-29.86	1.29	5.41	V
	3344	-54.14	-13	-41.14	-73.84	-57.75	1.56	7.31	V
	4184	-50.04	-13	-37.04	-72.04	-54.66	1.87	8.64	V
								V	
								V	
Highest	1696	-48.77	-13	-35.77	-61.98	-50.37	1.00	4.75	H
	2544	-27.63	-13	-14.63	-44.47	-29.61	1.30	5.44	H
	3392	-55.98	-13	-42.98	-74.97	-59.78	1.57	7.52	H
	4248	-44.94	-13	-31.94	-66.31	-49.54	1.90	8.65	H
									H
									H
	1696	-49.43	-13	-36.43	-63.17	-51.03	1.00	4.75	V
	2544	-30.30	-13	-17.30	-47.11	-32.28	1.30	5.44	V
	3392	-56.31	-13	-43.31	-76.07	-60.11	1.57	7.52	V
	4248	-52.24	-13	-39.24	-73.97	-56.84	1.90	8.65	V
								V	
								V	

Remark: Spurious emissions within 30-1000MHz were found more than 20dB below limit line.



GSM850 (EDGE class 8)									
Channel	Frequency ( MHz )	ERP ( dBm )	Limit ( dBm )	Over Limit ( dB )	SPA Reading (dBm)	S.G. Power ( dBm )	TX Cable loss ( dB )	TX Antenna Gain (dBi)	Polarization (H/V)
Lowest	1648	-45.27	-13	-32.27	-58.5	-47.03	0.98	4.89	H
	2472	-25.31	-13	-12.31	-41.86	-27.19	1.28	5.32	H
	3296	-51.23	-13	-38.23	-71.21	-54.64	1.54	7.10	H
	4120	-49.59	-13	-36.59	-71.42	-54.23	1.83	8.62	H
									H
									H
	1648	-46.50	-13	-33.50	-59.46	-48.26	0.98	4.89	V
	2472	-30.13	-13	-17.13	-46.6	-32.01	1.28	5.32	V
	3296	-53.43	-13	-40.43	-73.5	-56.84	1.54	7.10	V
	4120	-55.85	-13	-42.85	-76.48	-60.49	1.83	8.62	V
								V	
								V	
Middle	1672	-45.68	-13	-32.68	-59.01	-47.36	0.99	4.82	H
	2512	-24.00	-13	-11.00	-41.43	-25.97	1.29	5.41	H
	3344	-52.22	-13	-39.22	-72.8	-55.83	1.56	7.31	H
	4184	-47.52	-13	-34.52	-69.24	-52.14	1.87	8.64	H
									H
									H
	1672	-49.56	-13	-36.56	-62.72	-51.24	0.99	4.82	V
	2512	-27.36	-13	-14.36	-43.69	-29.33	1.29	5.41	V
	3344	-54.45	-13	-41.45	-74.51	-58.06	1.56	7.31	V
	4184	-53.49	-13	-40.49	-74.88	-58.11	1.87	8.64	V
								V	
								V	
Highest	1696	-48.77	-13	-35.77	-62.06	-50.37	1.00	4.75	H
	2544	-25.71	-13	-12.71	-41.7	-27.69	1.30	5.44	H
	3392	-55.38	-13	-42.38	-75.22	-59.18	1.57	7.52	H
	4248	-48.42	-13	-35.42	-70.91	-53.02	1.90	8.65	H
									H
									H
	1696	-49.16	-13	-36.16	-62.49	-50.76	1.00	4.75	V
	2544	-28.30	-13	-15.30	-44.83	-30.28	1.30	5.44	V
	3392	-57.14	-13	-44.14	-77.81	-60.94	1.57	7.52	V
	4248	-52.51	-13	-39.51	-74.52	-57.11	1.90	8.65	V
								V	
								V	

Remark: Spurious emissions within 30-1000MHz were found more than 20dB below limit line.



GSM1900 (GSM)									
Channel	Frequency ( MHz )	EIRP ( dBm )	Limit ( dBm )	Over Limit ( dB )	SPA Reading (dBm)	S.G. Power ( dBm )	TX Cable loss ( dB )	TX Antenna Gain (dBi)	Polarization (H/V)
Lowest	3700	-39.98	-13	-26.98	-60.49	-46.55	1.67	8.24	H
	5551	-53.51	-13	-40.51	-80.15	-60.58	2.65	9.72	H
	7401	-47.00	-13	-34.00	-80.23	-56.14	2.46	11.60	H
									H
									H
									H
	3700	-40.41	-13	-27.41	-60.92	-46.98	1.67	8.24	V
	5551	-53.34	-13	-40.34	-79.98	-60.41	2.65	9.72	V
	7401	-46.99	-13	-33.99	-80.22	-56.13	2.46	11.60	V
									V
Middle	3763	-36.79	-13	-23.79	-57.39	-43.42	1.69	8.32	H
	5639	-48.21	-13	-35.21	-75.09	-55.26	2.71	9.76	H
	7520	-46.51	-13	-33.51	-79.95	-55.9	2.42	11.81	H
									H
									H
									H
	3763	-44.99	-13	-31.99	-65.59	-51.62	1.69	8.32	V
	5639	-51.91	-13	-38.91	-78.79	-58.96	2.71	9.76	V
	7520	-46.95	-13	-33.95	-80.39	-56.34	2.42	11.81	V
									V
Highest	3819	-39.13	-13	-26.13	-59.81	-45.81	1.70	8.38	H
	5730	-51.74	-13	-38.74	-78.89	-58.77	2.76	9.79	H
	7639	-46.38	-13	-33.38	-80.01	-55.88	2.38	11.88	H
									H
									H
									H
	3819	-46.08	-13	-33.08	-66.76	-52.76	1.70	8.38	V
	5730	-53.08	-13	-40.08	-80.23	-60.11	2.76	9.79	V
	7639	-46.31	-13	-33.31	-79.94	-55.81	2.38	11.88	V
									V

Remark: Spurious emissions within 30-1000MHz were found more than 20dB below limit line.



GSM1900 (EDGE class 8)									
Channel	Frequency ( MHz )	EIRP ( dBm )	Limit ( dBm )	Over Limit ( dB )	SPA Reading (dBm)	S.G. Power ( dBm )	TX Cable loss ( dB )	TX Antenna Gain (dBi)	Polarization (H/V)
Lowest	3700	-44.71	-13	-31.71	-65.22	-51.28	1.67	8.24	H
	5551	-53.77	-13	-40.77	-80.41	-60.84	2.65	9.72	H
	7401	-47.07	-13	-34.07	-80.3	-56.21	2.46	11.60	H
									H
									H
									H
	3700	-47.87	-13	-34.87	-68.38	-54.44	1.67	8.24	V
	5551	-53.72	-13	-40.72	-80.36	-60.79	2.65	9.72	V
	7401	-46.89	-13	-33.89	-80.12	-56.03	2.46	11.60	V
									V
									V
									V
Middle	3763	-48.24	-13	-35.24	-68.84	-54.87	1.69	8.32	H
	5639	-53.41	-13	-40.41	-80.29	-60.46	2.71	9.76	H
	7520	-46.94	-13	-33.94	-80.38	-56.33	2.42	11.81	H
									H
									H
									H
	3763	-50.09	-13	-37.09	-70.69	-56.72	1.69	8.32	V
	5639	-53.50	-13	-40.50	-80.38	-60.55	2.71	9.76	V
	7520	-46.82	-13	-33.82	-80.26	-56.21	2.42	11.81	V
									V
									V
									V
Highest	3819	-47.74	-13	-34.74	-68.42	-54.42	1.70	8.38	H
	5730	-52.67	-13	-39.67	-79.82	-59.7	2.76	9.79	H
	7639	-46.40	-13	-33.40	-80.03	-55.9	2.38	11.88	H
									H
									H
									H
	3819	-52.57	-13	-39.57	-73.25	-59.25	1.70	8.38	V
	5730	-52.75	-13	-39.75	-79.9	-59.78	2.76	9.79	V
	7639	-46.46	-13	-33.46	-80.09	-55.96	2.38	11.88	V
									V
									V
									V

Remark: Spurious emissions within 30-1000MHz were found more than 20dB below limit line.



WCDMA Band V(RMC 12.2Kbps)									
Channel	Frequency ( MHz )	ERP ( dBm )	Limit ( dBm )	Over Limit ( dB )	SPA Reading (dBm)	S.G. Power ( dBm )	TX Cable loss ( dB )	TX Antenna Gain (dBi)	Polarization (H/V)
Lowest	1649	-65.99	-13	-52.99	-76.85	-67.74	0.98	4.88	H
	2473	-63.31	-13	-50.31	-77.41	-65.2	1.28	5.32	H
	3297	-60.92	-13	-47.92	-78.7	-64.34	1.54	7.11	H
									H
									H
									H
	1649	-65.93	-13	-52.93	-76.79	-67.68	0.98	4.88	V
	2473	-63.64	-13	-50.64	-77.74	-65.53	1.28	5.32	V
	3297	-60.98	-13	-47.98	-78.76	-64.4	1.54	7.11	V
									V
									V
									V
Middle	1672	-65.40	-13	-52.40	-76.38	-67.08	0.99	4.82	H
	2509	-62.19	-13	-49.19	-77.24	-64.15	1.29	5.41	H
	3345	-60.11	-13	-47.11	-78.75	-63.72	1.56	7.32	H
									H
									H
									H
	1672	-65.66	-13	-52.66	-76.61	-67.34	0.99	4.82	V
	2509	-63.92	-13	-50.92	-77.42	-65.88	1.29	5.41	V
	3345	-60.15	-13	-47.15	-78.4	-63.76	1.56	7.32	V
									V
									V
									V
Highest	1693	-65.70	-13	-52.70	-76.66	-67.31	1.00	4.76	H
	2540	-63.13	-13	-50.13	-77.6	-65.11	1.30	5.43	H
	3386	-60.72	-13	-47.72	-78.73	-64.5	1.57	7.50	H
									H
									H
									H
	1693	-65.48	-13	-52.48	-76.44	-67.09	1.00	4.76	V
	2540	-63.12	-13	-50.12	-77.59	-65.1	1.30	5.43	V
	3386	-60.69	-13	-47.69	-78.7	-64.47	1.57	7.50	V
									V
									V
									V

Remark: Spurious emissions within 30-1000MHz were found more than 20dB below limit line.



WCDMA Band II(RMC 12.2Kbps)									
Channel	Frequency ( MHz )	EIRP ( dBm )	Limit ( dBm )	Over Limit ( dB )	SPA Reading (dBm)	S.G. Power ( dBm )	TX Cable loss ( dB )	TX Antenna Gain (dBi)	Polarization (H/V)
Lowest	3707	-55.75	-13	-42.75	-76.26	-62.33	1.67	8.25	H
	5557	-53.04	-13	-40.04	-79.67	-60.1	2.66	9.72	H
	7410	-47.16	-13	-34.16	-80.39	-56.32	2.46	11.62	H
									H
									H
									H
	3707	-56.16	-13	-43.16	-76.67	-62.74	1.67	8.25	V
	5557	-52.99	-13	-39.99	-79.62	-60.05	2.66	9.72	V
	7410	-46.97	-13	-33.97	-80.2	-56.13	2.46	11.62	V
									V
									V
									V
Middle	3763	-57.37	-13	-44.37	-77.97	-64	1.69	8.32	H
	5639	-52.74	-13	-39.74	-79.62	-59.79	2.71	9.76	H
	7520	-46.75	-13	-33.75	-80.19	-56.14	2.42	11.81	H
									H
									H
									H
	3763	-56.66	-13	-43.66	-77.26	-63.29	1.69	8.32	V
	5639	-52.56	-13	-39.56	-79.44	-59.61	2.71	9.76	V
	7520	-46.88	-13	-33.88	-80.32	-56.27	2.42	11.81	V
									V
									V
									V
Highest	3815	-57.36	-13	-44.36	-78.03	-64.03	1.70	8.38	H
	5723	-51.86	-13	-38.86	-79.01	-58.9	2.75	9.79	H
	7630	-46.03	-13	-33.03	-79.63	-55.52	2.39	11.88	H
									H
									H
									H
	3815	-56.87	-13	-43.87	-77.54	-63.54	1.70	8.38	V
	5723	-51.97	-13	-38.97	-79.12	-59.01	2.75	9.79	V
	7630	-45.97	-13	-32.97	-79.57	-55.46	2.39	11.88	V
									V
									V
									V

Remark: Spurious emissions within 30-1000MHz were found more than 20dB below limit line.





WCDMA Band IV(RMC 12.2Kbps)									
Channel	Frequency ( MHz )	EIRP ( dBm )	Limit ( dBm )	Over Limit ( dB )	SPA Reading (dBm)	S.G. Power ( dBm )	TX Cable loss ( dB )	TX Antenna Gain (dBi)	Polarization (H/V)
Lowest	3425	-58.94	-13	-45.94	-78.26	-65.03	1.58	7.67	H
	5137	-53.31	-13	-40.31	-78.63	-60.59	2.42	9.70	H
	6850	-47.94	-13	-34.94	-79.64	-55.92	2.64	10.62	H
									H
									H
									H
	3425	-58.06	-13	-45.06	-78.29	-64.15	1.58	7.67	V
	5137	-53.49	-13	-40.49	-79.04	-60.77	2.42	9.70	V
	6850	-47.96	-13	-34.96	-79.88	-55.94	2.64	10.62	V
									V
Middle	3464	-57.80	-13	-44.80	-77.99	-64.05	1.59	7.84	H
	5198	-53.12	-13	-40.12	-79.25	-60.37	2.45	9.70	H
	6930	-47.13	-13	-34.13	-79.74	-55.23	2.61	10.72	H
									H
									H
									H
	3464	-58.06	-13	-45.06	-78.32	-64.31	1.59	7.84	V
	5198	-53.83	-13	-40.83	-79.43	-61.08	2.45	9.70	V
	6930	-47.62	-13	-34.62	-79.81	-55.72	2.61	10.72	V
									V
Highest	3505	-57.12	-13	-44.12	-78	-63.52	1.61	8.01	H
	5258	-53.56	-13	-40.56	-79.43	-60.77	2.49	9.70	H
	7010	-46.69	-13	-33.69	-79.38	-54.92	2.59	10.82	H
									H
									H
									H
	3505	-57.77	-13	-44.77	-78.03	-64.17	1.61	8.01	V
	5258	-53.13	-13	-40.13	-79.14	-60.34	2.49	9.70	V
	7010	-47.73	-13	-34.73	-79.55	-55.96	2.59	10.82	V
									V

Remark: Spurious emissions within 30-1000MHz were found more than 20dB below limit line.