

FCC Test Report

(PART 27)

Report No.: RF160303C04-2

FCC ID: NM82PS6700A

Test Model: 2PS6700A

Received Date: Mar. 03, 2016

Test Date: Mar. 17, 2016 ~ Mar. 25, 2016

Issued Date: Apr. 14, 2016

Applicant: HTC Corporation

Address: 1F, 6-3 Baoqiang Road, Xindian District, New Taipei City, Taiwan 231

Issued By: Bureau Veritas Consumer Products Services (H.K.) Ltd., Taoyuan Branch

Lab Address: No. 47-2, 14th Ling, Chia Pau Vil., Lin Kou Dist., New Taipei City, Taiwan (R.O.C)

Test Location (1): No. 19, Hwa Ya 2nd Rd, Wen Hwa Tsuen, Kwei Shan Hsiang, Taoyuan Hsien 333, Taiwan, R.O.C.

Test Location (2): No.215, Sec. 3, Beixin Rd., Xindian Dist., New Taipei City 231, Taiwan, R.O.C



This report is for your exclusive use. Any copying or replication of this report to or for any other person or entity, or use of our name or trademark, is permitted only with our prior written permission. This report sets forth our findings solely with respect to the test samples identified herein. The results set forth in this report are not indicative or representative of the quality or characteristics of the lot from which a test sample was taken or any similar or identical product unless specifically and expressly noted. Our report includes all of the tests requested by you and the results thereof based upon the information that you provided to us. You have 60 days from date of issuance of this report to notify us of any material error or omission caused by our negligence, provided, however, that such notice shall be in writing and shall specifically address the issue you wish to raise. A failure to raise such issue within the prescribed time shall constitute your unqualified acceptance of the completeness of this report, the tests conducted and the correctness of the report contents. Unless specific mention, the uncertainty of measurement has been explicitly taken into account to declare the compliance or non-compliance to the specification. The report must not be used by the client to claim product certification, approval, or endorsement by TAF or any government agency

Table of Contents

Release Control Record	3
1 Certificate of Conformity	4
2 Summary of Test Results.....	5
2.1 Measurement Uncertainty.....	6
2.2 Test Site and Instruments	7
3 General Information	8
3.1 General Description of EUT	8
3.2 Configuration of System under Test.....	9
3.2.1 Description of Support Units.....	9
3.3 Test Mode Applicability and Tested Channel Detail	10
3.4 EUT Operating Conditions	12
3.5 General Description of Applied Standards.....	12
4 Test Types and Results	13
4.1 Output Power Measurement.....	13
4.1.1 Limits of Output Power Measurement	13
4.1.2 Test Procedures.....	13
4.1.3 Test Setup.....	14
4.1.4 Test Results	15
4.2 Frequency Stability Measurement	18
4.2.1 Limits of Frequency Stability Measurement.....	18
4.2.2 Test Procedure	18
4.2.3 Test Setup.....	18
4.2.4 Test Results	19
4.3 Occupied Bandwidth Measurement.....	20
4.3.1 Limits of Occupied Bandwidth Measurement	20
4.3.2 Test Procedure	20
4.3.3 Test Setup.....	20
4.3.4 Test Result	21
4.4 Band Edge Measurement	23
4.4.1 Limits of Band Edge Measurement	23
4.4.2 Test Setup.....	23
4.4.3 Test Procedures.....	23
4.4.4 Test Results	24
4.5 Peak to Average Ratio	28
4.5.1 Limits of Peak to Average Ratio Measurement	28
4.5.2 Test Setup.....	28
4.5.3 Test Procedures.....	28
4.5.4 Test Results	29
4.6 Conducted Spurious Emissions.....	31
4.6.1 Limits of Conducted Spurious Emissions Measurement.....	31
4.6.2 Test Setup.....	31
4.6.3 Test Procedure	31
4.6.4 Test Results	32
4.7 Radiated Emission Measurement.....	33
4.7.1 Limits of Radiated Emission Measurement	33
4.7.2 Test Procedure	33
4.7.3 Deviation from Test Standard	33
4.7.4 Test Setup.....	33
4.7.5 Test Results	34
5 Pictures of Test Arrangements.....	38
Appendix – Information on the Testing Laboratories	39



A D T

Release Control Record

Issue No.	Description	Date Issued
RF160303C04-2	Original Release	Apr. 14, 2016

1 Certificate of Conformity

Product: Smartphone

Brand: HTC

Test Model: 2PS6700A

Sample Status: Production Unit

Applicant: HTC Corporation

Test Date: Mar. 17, 2016 ~ Mar. 25, 2016

Standards: FCC Part 27, Subpart C

The above equipment has been tested by **Bureau Veritas Consumer Products Services (H.K.) Ltd., Taoyuan Branch**, and found compliance with the requirement of the above standards. The test record, data evaluation & Equipment Under Test (EUT) configurations represented herein are true and accurate accounts of the measurements of the sample's EMC characteristics under the conditions specified in this report.

Prepared by : , **Date:** Apr. 14, 2016
Ivonne Wu / Supervisor

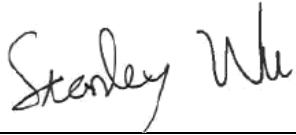
Approved by : , **Date:** Apr. 14, 2016
Stanley Wu / Assistant Manager

2 Summary of Test Results

Applied Standard: FCC Part 27 & Part 2 (LTE 13)			
FCC Clause	Test Item	Result	Remarks
2.1046 27.50(b)(10)	Maximum Peak Output Power	Pass	Meet the requirement of limit.
2.1055 27.54	Frequency Stability	Pass	Meet the requirement of limit.
2.1049 27.53(g)	Occupied Bandwidth	Pass	Meet the requirement of limit.
27.50(d)(5)	Peak to Average Ratio	Pass	Meet the requirement of limit.
27.53(g)	Band Edge Measurements	Pass	Meet the requirement of limit.
2.1051 27.53(g)	Conducted Spurious Emissions	Pass	Meet the requirement of limit.
2.1053 27.53(g)	Radiated Spurious Emissions	Pass	Meet the requirement of limit. Minimum passing margin is -18.43 dB at 1564.00 MHz.

Applied Standard: FCC Part 27 & Part 2 (LTE 17)			
FCC Clause	Test Item	Result	Remarks
2.1046 27.50(C)(10)	Maximum Peak Output Power	Pass	Meet the requirement of limit.
2.1055 27.54	Frequency Stability	Pass	Meet the requirement of limit.
2.1049 27.53(g)	Occupied Bandwidth	Pass	Meet the requirement of limit.
27.50(d)(5)	Peak to Average Ratio	Pass	Meet the requirement of limit.
27.53(g)	Band Edge Measurements	Pass	Meet the requirement of limit.
2.1051 27.53(g)	Conducted Spurious Emissions	Pass	Meet the requirement of limit.
2.1053 27.53(g)	Radiated Spurious Emissions	Pass	Meet the requirement of limit. Minimum passing margin is -37.39 dB at 140.43 MHz.

2.1 Measurement Uncertainty

Where relevant, the following measurement uncertainty levels have been estimated for tests performed on the EUT as specified in CISPR 16-4-2:

Measurement	Frequency	Expanded Uncertainty (k=2) (\pm)
Conducted Emissions at mains ports	150 kHz ~ 30 MHz	2.44 dB
Radiated Emissions up to 1 GHz	30 MHz ~ 200 MHz	2.0153 dB
	200 MHz ~ 1000 MHz	2.0224 dB
Radiated Emissions above 1 GHz	1 GHz ~ 18 GHz	1.0121 dB
	18 GHz ~ 40 GHz	1.1508 dB

2.2 Test Site and Instruments

Description & Manufacturer	Model No.	Serial No.	Date of Calibration	Due Date of Calibration
Test Receiver Agilent Technologies	N9038A	MY52260177	May 19, 2015	May 18, 2016
Spectrum Analyzer ROHDE & SCHWARZ	FSU43	101261	Dec. 17, 2015	Dec. 16, 2016
BILOG Antenna SCHWARZBECK	VULB9168	9168-472	Jan. 07, 2016	Jan. 06, 2017
HORN Antenna ETS-Lindgren	3117	00143293	Jan. 04, 2016	Jan. 03, 2017
Double Ridge Guide Horn Antenna EMCO	3115	5619	Jan. 04, 2016	Jan. 03, 2017
BILOG Antenna SCHWARZBECK	VULB 9168	9168-153	Jan. 07, 2016	Jan. 06, 2017
Agilent Communications Tester-Wireless	8960 Series 10	MY53201073	Jul. 03, 2015	Jul. 02, 2017
Preamplifier Agilent	310N	187226	Jun. 29, 2015	Jun. 28, 2016
Preamplifier Agilent	83017A	MY39501357	Jun. 29, 2015	Jun. 28, 2016
Power Meter Anritsu	ML2495A	1232002	Sep. 21, 2015	Sep. 20, 2016
Power Sensor Anritsu	MA2411B	1207325	Sep. 21, 2015	Sep. 20, 2016
RF signal cable ETS-LINDGREN	5D-FB	Cable-CH1-01(R FC-SMS-100-SM S-120+RFC-SMS -100-SMS-400)	Jun. 27, 2015	Jun. 26, 2016
RF signal cable ETS-LINDGREN	8D-FB	Cable-CH1-02(R FC-SMS-100-SM S-24)	Jun. 27, 2015	Jun. 26, 2016
Software BV ADT	E3 8.130425b	NA	NA	NA
Antenna Tower MF	NA	NA	NA	NA
Turn Table MF	NA	NA	NA	NA
Antenna Tower & Turn Table Controller MF	MF-7802	NA	NA	NA
Communications Tester-Wireless Agilent	8960 Series 10	MY53201073	Jul. 03, 2015	Jul. 02, 2017
Radio Communication Analyzer Anritsu	MT8820C	6201240432	Jul. 06, 2015	Jul. 05, 2017

- Note: 1. The calibration interval of the above test instruments is 12 / 24 months and the calibrations are traceable to NML/ROC and NIST/USA.
2. The test was performed in HsinTien Chamber 1.
3. The horn antenna and preamplifier (model: 83017A) are used only for the measurement of emission frequency above 1 GHz if tested.
4. The FCC Site Registration No. is 149147.
5. The IC Site Registration No. is IC7450I-1.

3 General Information

3.1 General Description of EUT

Product	Smartphone	
Brand	HTC	
Test Model	2PS6700A	
Status of EUT	Production Unit	
Power Supply Rating	5.0 Vdc (adapter or host equipment) 3.85 Vdc (Li-ion battery)	
Modulation Type	LTE	QPSK, 16QAM
Frequency Range	LTE Band 13 (Channel Bandwidth: 5 MHz)	779.5 ~ 784.5 MHz
	LTE Band 13 (Channel Bandwidth: 10 MHz)	782.0 MHz
	LTE Band 17 (Channel Bandwidth: 5 MHz)	706.5 ~ 713.5 MHz
	LTE Band 17 (Channel Bandwidth: 10 MHz)	709 ~ 711 MHz
Emission Designator	LTE Band 13 (Channel Bandwidth: 5 MHz)	4M50G7D
	LTE Band 13 (Channel Bandwidth: 10 MHz)	8M97G7D
	LTE Band 17 (Channel Bandwidth: 5 MHz)	4M49W7D
	LTE Band 17 (Channel Bandwidth: 10 MHz)	8M99G7D
Max. ERP Power	LTE Band 13 (Channel Bandwidth: 5 MHz)	71.19mW
	LTE Band 13 (Channel Bandwidth: 10 MHz)	74.08mW
	LTE Band 17 (Channel Bandwidth: 5 MHz)	44.32mW
	LTE Band 17 (Channel Bandwidth: 10 MHz)	42.94mW
Antenna Type	Fixed Internal Antenna	
Accessory Device	Refer to Note as below	
Data Cable Supplied	Refer to Note as below	

Note:

1. The EUT's accessories list refers to Ext. Pho.
2. The above EUT information is declared by manufacturer and for more detailed features description, please refer to the manufacturer's specifications or user's manual.

3.2 Configuration of System under Test

<Radiated Emission Test>

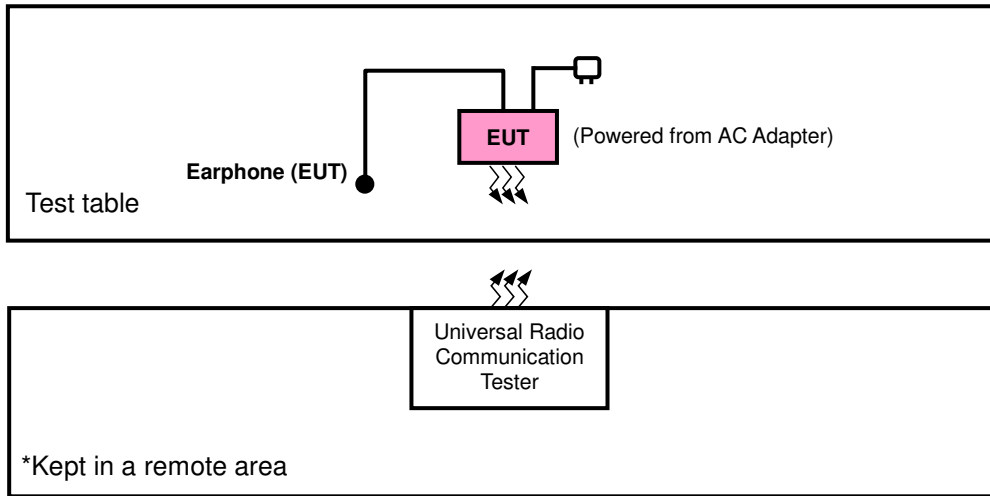

<E.R.P. / E.I.R.P. Test>

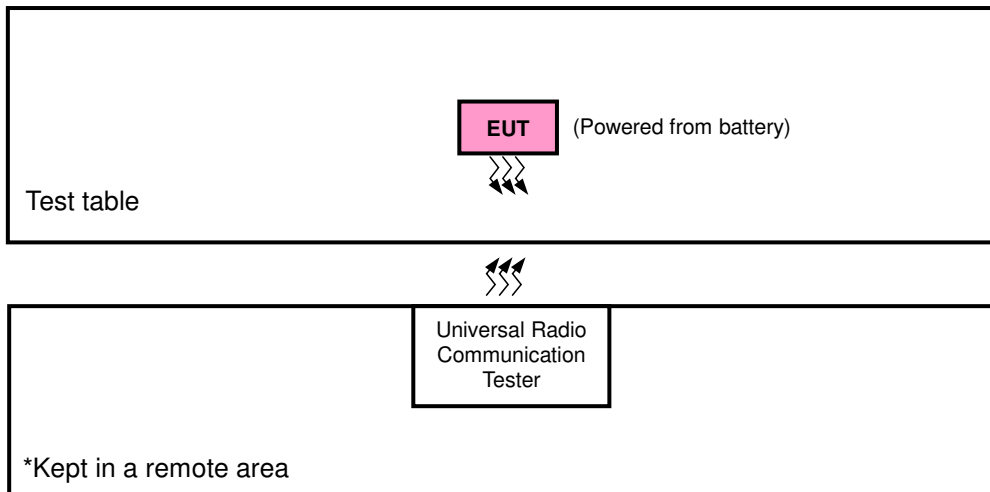

3.2.1 Description of Support Units

The EUT has been tested as an independent unit together with other necessary accessories or support units.

3.3 Test Mode Applicability and Tested Channel Detail

Pre-Scan has been conducted to determine the worst-case mode from all possible combinations between available modulations, data rates, XYZ axis, and antenna ports

The worst case was found when positioned as the table below. Following channel(s) was (were) selected for the final test as listed below:

Band	ERP	Radiated Emission
LTE Band 13	X-plane	X-axis
LTE Band 17	Y-plane	Z-axis

LTE Band 13

EUT Configure Mode	Test Item	Available Channel	Tested Channel	Channel Bandwidth	Modulation	Mode		
-	ERP	23205 to 23255	23205, 23230, 23255	5 MHz	QPSK, 16QAM	1 RB / 0 RB Offset		
		23230	23230	10 MHz	QPSK, 16QAM	1 RB / 0 RB Offset		
-	Frequency Stability	23205 to 23255	23230	5 MHz	QPSK	1 RB / 0 RB Offset		
		23230	23230	10 MHz	QPSK	1 RB / 0 RB Offset		
-	Occupied Bandwidth	23205 to 23255	23205, 23230, 23255	5 MHz	QPSK, 16QAM	25 RB / 0 RB Offset		
		23230	23230	10 MHz	QPSK, 16QAM	50 RB / 0 RB Offset		
-	Peak to Average Ratio	23205 to 23255	23205, 23230, 23255	5 MHz	QPSK, 16QAM	1 RB / 0 RB Offset		
		23230	23230	10 MHz	QPSK, 16QAM	1 RB / 0 RB Offset		
-	Band Edge	23205 to 23255	23205	5 MHz	QPSK	1 RB / 0 RB Offset 25 RB / 0 RB Offset		
			23255	5 MHz	QPSK	1 RB / 24 RB Offset 25 RB / 0 RB Offset		
		23230	23230	10 MHz	QPSK	1 RB / 0 RB Offset 50 RB / 0 RB Offset		
			23230	10 MHz	QPSK	1 RB / 49 RB Offset 50 RB / 0 RB Offset		
		-	Conducted Emission	23205 to 23255	23230	5 MHz	QPSK	1 RB / 0 RB Offset
				23230	23230	10 MHz	QPSK	1 RB / 0 RB Offset
-	Radiated Emission	23230	23230	10 MHz	QPSK	1 RB / 0 RB Offset		

Note: This device was tested under all bandwidths, RB configurations and modulations. The worst case was found in QPSK modulation.

LTE Band 17

EUT Configure Mode	Test Item	Available Channel	Tested Channel	Channel Bandwidth	Modulation	Mode		
-	ERP	23755 to 23825	23755, 23790, 23825	5 MHz	QPSK, 16QAM	1 RB / 0 RB Offset		
		23780 to 23800	23780, 23790, 23800	10 MHz	QPSK, 16QAM	1 RB / 0 RB Offset		
-	Frequency Stability	23755 to 23825	23790	5 MHz	QPSK	1 RB / 0 RB Offset		
		23780 to 23800	23790	10 MHz	QPSK	1 RB / 0 RB Offset		
-	Occupied Bandwidth	23755 to 23825	23755, 23790, 23825	5 MHz	QPSK, 16QAM	25 RB / 0 RB Offset		
		23780 to 23800	23780, 23790, 23800	10 MHz	QPSK, 16QAM	50 RB / 0 RB Offset		
-	Peak to Average Ratio	23755 to 23825	23755, 23790, 23825	5 MHz	QPSK, 16QAM	1 RB / 0 RB Offset		
		23780 to 23800	23780, 23790, 23800	10 MHz	QPSK, 16QAM	1 RB / 0 RB Offset		
-	Band Edge	23755 to 23825	23755	5 MHz	QPSK	1 RB / 0 RB Offset 25 RB / 0 RB Offset		
			23825	5 MHz	QPSK	1 RB / 24 RB Offset 25 RB / 0 RB Offset		
		23780 to 23800	23780	10 MHz	QPSK	1 RB / 0 RB Offset 50 RB / 0 RB Offset		
			23800	10 MHz	QPSK	1 RB / 49 RB Offset 50 RB / 0 RB Offset		
		-	Conducted Emission	23755 to 23825	23790	5 MHz	QPSK	1 RB / 0 RB Offset
				23780 to 23800	23790	10 MHz	QPSK	1 RB / 0 RB Offset
-	Radiated Emission	23780 to 23800	23790	10 MHz	QPSK	1 RB / 0 RB Offset		

Note: This device was tested under all bandwidths, RB configurations and modulations. The worst case was found in QPSK modulation.

Test Condition:

Test Item	Environmental Conditions	Input Power	Tested By
ERP	25 deg. C, 65 % RH	3.85 Vdc	Carlos Chen
Frequency Stability	25 deg. C, 65 % RH	3.85 Vdc	Carlos Chen
Occupied Bandwidth	25 deg. C, 65 % RH	3.85 Vdc	Carlos Chen
Band Edge	25 deg. C, 65 % RH	3.85 Vdc	Carlos Chen
Peak to Average Ratio	25 deg. C, 65 % RH	3.85 Vdc	Carlos Chen
Condcudeted Emission	25 deg. C, 65 % RH	3.85 Vdc	Carlos Chen
Radiated Emission	25 deg. C, 65 % RH	120 Vac, 60 Hz	Charles Hsiao

3.4 EUT Operating Conditions

The EUT makes a call to the communication simulator. The communication simulator station system controlled a EUT to export maximum output power under transmission mode and specific channel frequency

3.5 General Description of Applied Standards

The EUT is a RF Product. According to the specifications of the manufacturer, it must comply with the requirements of the following standards:

FCC 47 CFR Part 2

FCC 47 CFR Part 27

KDB 971168 D01 Power Meas License Digital Systems v02r02

ANSI/TIA/EIA-603-D 2010

NOTE: All test items have been performed and recorded as per the above standards.

4 Test Types and Results

4.1 Output Power Measurement

4.1.1 Limits of Output Power Measurement

Portable stations (hand-held devices) operating in the 699-787 MHz band are limited to 3 watts ERP

4.1.2 Test Procedures

EIRP / ERP Measurement:

- a. All measurements were done at low, middle and high operational frequency range. RBW and VBW is 10 MHz for LTE mode.
- b. Substitution method is used for E.I.R.P measurement. In the semi-anechoic chamber, EUT placed on the 0.8 m height of Turn Table, rotated the table around 360 degrees to search the maximum radiation power and receiver antenna shall be rotated vertical and horizontal polarization and moved height from 1 m to 4 m to find the maximum polar radiated power. The "Read Value" is the spectrum reading the maximum power value.
- c. The substitution horn antenna is substituted for EUT at the same position and signals generator export the CW signal to the substitution antenna via a tx cable. Rotated the Turn Table and moved receiving antenna to find the maximum radiation power. Adjust output power level of S.G to get a Value of spectrum reading equal to "Read Value" of step b. Record the power level of S.G.
- d. $EIRP = \text{Output power level of S.G} - \text{TX cable loss} + \text{Antenna gain of substitution horn}$. E.R.P power can be calculated form E.I.R.P power by subtracting the gain of dipole, $E.R.P \text{ power} = E.I.P.R \text{ power} - 2.15 \text{ dBi}$.

Conducted Power Measurement:

- a. The EUT was set up for the maximum power with LTE link data modulation and link up with simulator.
- b. Set the EUT to transmit under low, middle and high channel and record the power level shown on simulator.

4.1.3 Test Setup

EIRP / ERP Measurement:

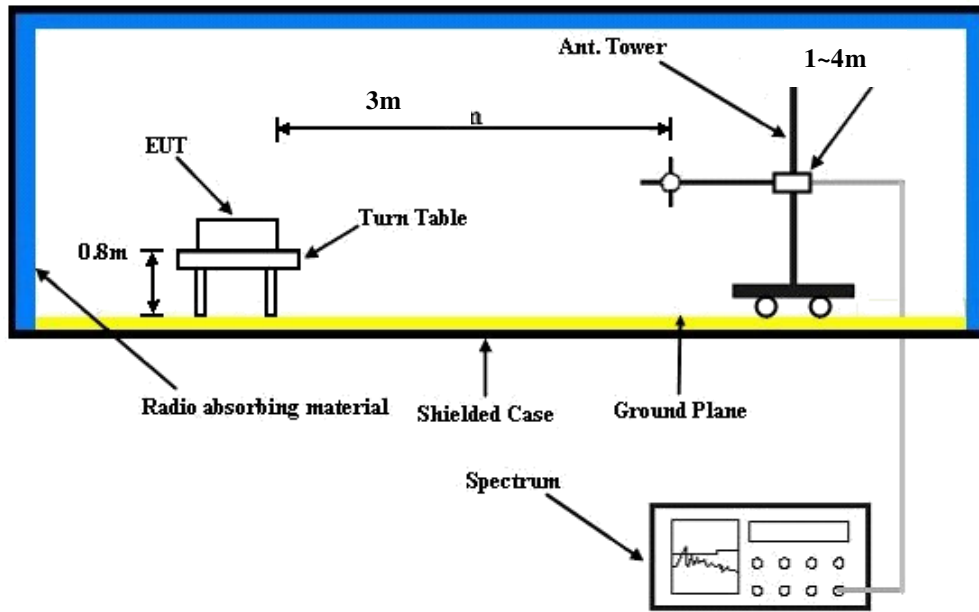

For the actual test configuration, please refer to the attached file (Test Setup Photo).

Conducted Power Measurement:

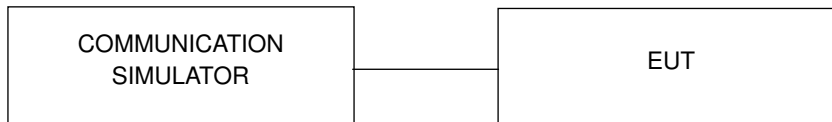

4.1.4 Test Results

Conducted Output Power (dBm)

Band / BW	RB Size	RB Offset	QPSK			3GPP MPR (dB)	16QAM			3GPP MPR (dB)
			Low Ch 23205	Mid Ch 23230	High Ch 23255		Low Ch 23205	Mid Ch 23230	High Ch 23255	
			779.5 MHz	782.0 MHz	784.5 MHz		779.5 MHz	782.0 MHz	784.5 MHz	
13 / 5M	1	0	21.91	22.01	22.12	0	20.93	21.05	21.17	1
	1	12	21.79	21.98	22.07	0	20.82	21.01	21.13	1
	1	24	21.52	21.62	21.70	0	20.55	20.63	20.71	1
	12	0	20.63	20.70	20.86	1	19.60	19.69	19.89	2
	12	6	20.58	20.68	20.79	1	19.55	19.67	19.80	2
	12	13	20.56	20.66	20.77	1	19.53	19.63	19.77	2
	25	0	20.54	20.64	20.75	1	19.52	19.60	19.71	2

Band / BW	RB Size	RB Offset	QPSK		3GPP MPR (dB)	16QAM		3GPP MPR (dB)
			Mid Ch 23230			Mid Ch 23230		
			782.0 MHz			782.0 MHz		
13 / 10M	1	0	22.26		0	21.28		1
	1	24	22.23		0	21.25		1
	1	49	22.20		0	21.21		1
	25	0	21.30		1	20.25		2
	25	12	21.29		1	20.24		2
	25	25	21.27		1	20.22		2
	50	0	21.28		1	20.23		2

Band / BW	RB Size	RB Offset	QPSK			3GPP MPR (dB)	16QAM			3GPP MPR (dB)
			Low Ch 23755	Mid Ch 23790	High Ch 23825		Low Ch 23755	Mid Ch 23790	High Ch 23825	
			706.5 MHz	710.0 MHz	713.5 MHz		706.5 MHz	710.0 MHz	713.5 MHz	
17 / 5M	1	0	21.78	21.83	21.75	0	20.82	20.88	20.78	1
	1	12	21.74	21.81	21.66	0	20.77	20.85	20.71	1
	1	24	21.62	21.71	21.60	0	20.66	20.71	20.58	1
	12	0	20.84	20.89	20.75	1	19.84	19.87	19.72	2
	12	6	20.69	20.78	20.67	1	19.69	19.75	19.63	2
	12	13	20.74	20.82	20.73	1	19.75	19.80	19.69	2
	25	0	20.69	20.75	20.65	1	19.61	19.71	19.60	2

Band / BW	RB Size	RB Offset	QPSK			3GPP MPR (dB)	16QAM			3GPP MPR (dB)
			Low Ch 23780	Mid Ch 23790	High Ch 23800		Low Ch 23780	Mid Ch 23790	High Ch 23800	
			709.0 MHz	710.0 MHz	711.0 MHz		709.0 MHz	710.0 MHz	711.0 MHz	
17 / 10M	1	0	21.83	21.88	21.80	0	20.86	20.93	20.82	1
	1	24	21.80	21.86	21.76	0	20.84	20.90	20.75	1
	1	49	21.74	21.77	21.63	0	20.75	20.78	20.71	1
	25	0	20.94	20.99	20.92	1	19.94	19.99	19.86	2
	25	12	20.84	20.89	20.81	1	19.80	19.86	19.76	2
	25	25	20.90	20.93	20.85	1	19.83	19.91	19.81	2
	50	0	20.83	20.87	20.80	1	19.78	19.82	19.74	2

ERP Power (dBm)

LTE Band 13							
Channel Bandwidth: 5 MHz / QPSK							
Plane	Channel	Frequency (MHz)	LVL (dBm)	Correction Factor (dB)	ERP (dBm)	ERP (mW)	Polarization (H/V)
X	23205	779.5	-12.15	32.771	18.47	70.32	H
	23230	782.0	-12.23	32.741	18.36	68.56	
	23255	784.5	-12.18	32.854	18.52	71.19	
	23205	779.5	-16.85	32.5	13.50	22.39	V
	23230	782.0	-16.74	32.52	13.63	23.07	
	23255	784.5	-16.83	32.62	13.64	23.12	
Channel Bandwidth: 5 MHz / 16QAM							
X	23205	779.5	-13.23	32.771	17.39	54.84	H
	23230	782.0	-13.54	32.741	17.05	50.71	
	23255	784.5	-13.68	32.854	17.02	50.40	
	23205	779.5	-17.59	32.5	12.76	18.88	V
	23230	782.0	-17.84	32.52	12.53	17.91	
	23255	784.5	-17.88	32.62	12.59	18.16	

LTE Band 13							
Channel Bandwidth: 10 MHz / QPSK							
Plane	Channel	Frequency (MHz)	LVL (dBm)	Correction Factor (dB)	ERP (dBm)	ERP (mW)	Polarization (H/V)
X	23230	782.0	-11.89	32.737	18.70	74.08	H
	23230	782.0	-16.95	32.52	13.42	21.98	V
Channel Bandwidth: 10 MHz / 16QAM							
X	23230	782.0	-12.69	32.737	17.90	61.62	H
	23230	782.0	-17.48	32.52	12.89	19.45	V

LTE Band 17							
Channel Bandwidth: 5 MHz / QPSK							
Plane	Channel	Frequency (MHz)	LVL (dBm)	Correction Factor (dB)	ERP (dBm)	ERP (mW)	Polarization (H/V)
Y	23755	706.5	-14.37	32.719	16.20	41.68	H
	23790	710.0	-14.12	32.736	16.47	44.32	
	23825	713.5	-14.09	32.591	16.35	43.16	
	23755	706.5	-18.65	32.69	11.89	15.45	V
	23790	710.0	-18.72	32.81	11.94	15.63	
	23825	713.5	-18.98	32.74	11.61	14.49	
Channel Bandwidth: 5 MHz / 16QAM							
Y	23755	706.5	-14.86	32.719	15.71	37.23	H
	23790	710.0	-14.93	32.736	15.66	36.78	
	23825	713.5	-14.85	32.591	15.59	36.23	
	23755	706.5	-19.66	32.69	10.88	12.25	V
	23790	710.0	-19.80	32.81	10.86	12.19	
	23825	713.5	-19.96	32.74	10.63	11.56	

LTE Band 17							
Channel Bandwidth: 10 MHz / QPSK							
Plane	Channel	Frequency (MHz)	LVL (dBm)	Correction Factor (dB)	ERP (dBm)	ERP (mW)	Polarization (H/V)
Y	23780	709.0	-14.45	32.727	16.13	40.99	H
	23790	710.0	-14.26	32.739	16.33	42.94	
	23800	711.0	-14.52	32.728	16.06	40.35	
	23780	709.0	-18.76	32.75	11.84	15.28	V
	23790	710.0	-18.85	32.81	11.81	15.17	
	23800	711.0	-19.12	32.84	11.57	14.35	
Channel Bandwidth: 10 MHz / 16QAM							
Y	23780	709.0	-15.36	32.727	15.22	33.24	H
	23790	710.0	-15.26	32.739	15.33	34.11	
	23800	711.0	-15.47	32.728	15.11	32.42	
	23780	709.0	-19.65	32.75	10.95	12.45	V
	23790	710.0	-19.87	32.81	10.79	11.99	
	23800	711.0	-19.75	32.84	10.94	12.42	

4.2 Frequency Stability Measurement

4.2.1 Limits of Frequency Stability Measurement

The frequency stability shall be sufficient to ensure that the fundamental emissions stay within the authorized bands of operation.

4.2.2 Test Procedure

- a. Device is placed at the oven room. The oven room could control the temperatures and humidity. Power warm up is at least 15 min and power applied should perform before recording frequency error.
- b. EUT is connected the external power supply to control the DC input power. The test voltage range is from minimum to maximum working voltage. Each step shall be record the frequency error rate.
- c. The temperature range step is 10 degrees in this test items. All temperature levels shall be hold the ± 0.5 °C during the measurement testing. The each temperature step shall be at least 0.5 hours, consider the EUT could be test under the stability condition.

NOTE: The frequency error was recorded frequency error from the communication simulator.

4.2.3 Test Setup

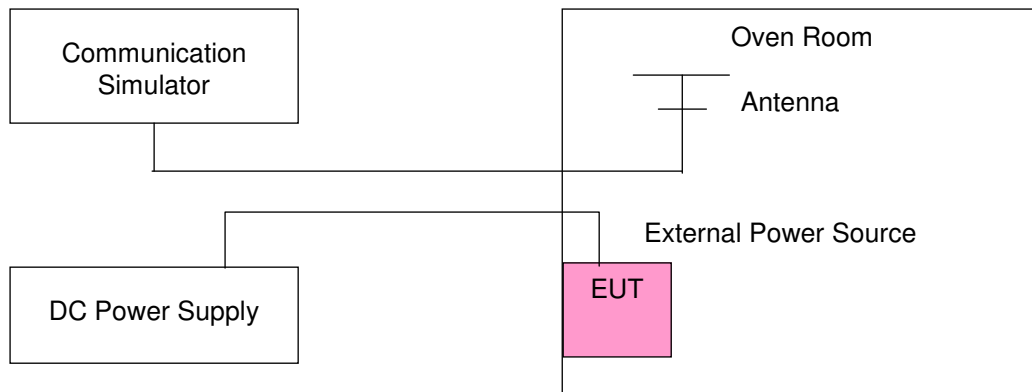

4.2.4 Test Results

Frequency Error vs. Voltage

Voltage (Volts)	Frequency Error (ppm)				Limit (ppm)
	LTE Band 13		LTE Band 17		
	5 MHz	10 MHz	5 MHz	10 MHz	
3.85	0.0019	0.0012	0.0027	0.0015	2.5
3.6	0.0024	0.0019	0.0039	0.0027	2.5
4.4	0.0036	0.0006	0.0001	0.0041	2.5

NOTE: The applicant defined the normal working voltage of the battery is from 3.6 Vdc to 4.4 Vdc.

Frequency Error vs. Temperature

Temp. (°C)	Frequency Error (ppm)				Limit (ppm)
	LTE Band 13		LTE Band 17		
	5 MHz	10 MHz	5 MHz	10 MHz	
-30	0.0023	0.0024	0.0048	0.0025	2.5
-20	0.0008	0.0018	0.0037	0.0037	2.5
-10	0.0006	0.0031	0.0008	0.0037	2.5
0	0.0020	0.0049	0.0048	0.0038	2.5
10	0.0003	0.0022	0.0032	0.0042	2.5
20	-0.0047	-0.0001	-0.0020	-0.0006	2.5
30	-0.0043	-0.0004	-0.0011	-0.0045	2.5
40	-0.0006	-0.0050	-0.0015	-0.0010	2.5
50	-0.0031	-0.0014	-0.0051	-0.0017	2.5
55	-0.0038	-0.0006	-0.0014	-0.0046	2.5

4.3 Occupied Bandwidth Measurement

4.3.1 Limits of Occupied Bandwidth Measurement

The width of a frequency band such that, below the lower and above the upper frequency limits, the mean powers emitted are each equal to a specified percentage 0.5 % of the total mean power of a given emission.

4.3.2 Test Procedure

- The conducted occupied bandwidth used the power splitter via EUT RF power connector between simulation base station and spectrum analyzer.
- Use OBW measurement function of Spectrum analyzer to measure 99 % occupied bandwidth.

4.3.3 Test Setup

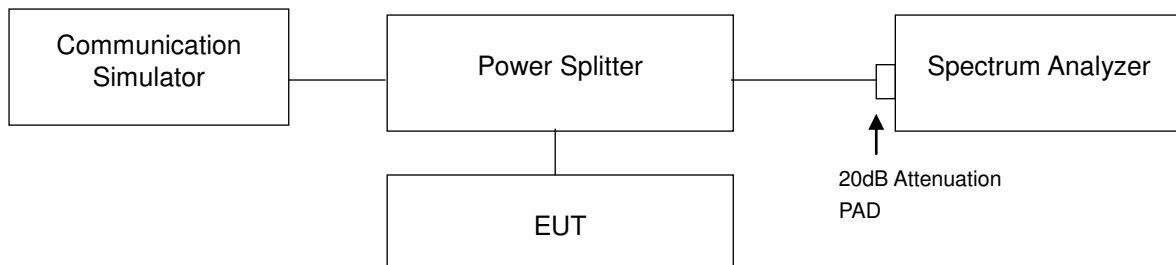

4.3.4 Test Result

LTE Band 13							
Channel Bandwidth: 5 MHz				Channel Bandwidth: 10 MHz			
Channel	Frequency (MHz)	99 % Occupied Bandwidth (MHz)		Channel	Frequency (MHz)	99 % Occupied Bandwidth (MHz)	
		QPSK	16QAM			QPSK	16QAM
23205	779.5	4.4881	4.4872	23230	782.0	8.9732	8.9718
23230	782.0	4.4975	4.4950				
23255	784.5	4.4919	4.4872				





LTE Band 17

Channel Bandwidth: 5 MHz				Channel Bandwidth: 10 MHz			
Channel	Frequency (MHz)	99 % Occupied Bandwidth (MHz)		Channel	Frequency (MHz)	99 % Occupied Bandwidth (MHz)	
		QPSK	16QAM			QPSK	16QAM
23755	706.5	4.4906	4.4923	23780	709.0	8.9878	8.9790
23790	710.0	4.4920	4.4880	23790	710.0	8.9767	8.9704
23825	713.5	4.4880	4.4876	23800	711.0	8.9723	8.9682

Spectrum Plot of Worst Value

5 MHz / QPSK		5 MHz / 16QAM	
<p>Center Freq 710.000000 MHz</p> <p>Occupied Bandwidth: 4.4920 MHz</p> <p>Total Power: 23.6 dBm</p> <p>Transmit Freq Error: 3.069 kHz</p> <p>x dB Bandwidth: 4.795 MHz</p>	<p>Center Freq 706.500000 MHz</p> <p>Occupied Bandwidth: 4.4923 MHz</p> <p>Total Power: 22.6 dBm</p> <p>Transmit Freq Error: -1.896 kHz</p> <p>x dB Bandwidth: 4.803 MHz</p>		
<p>Center Freq 709.000000 MHz</p> <p>Occupied Bandwidth: 8.9878 MHz</p> <p>Total Power: 23.5 dBm</p> <p>Transmit Freq Error: 3.501 kHz</p> <p>x dB Bandwidth: 9.554 MHz</p>	<p>Center Freq 709.000000 MHz</p> <p>Occupied Bandwidth: 8.9790 MHz</p> <p>Total Power: 22.3 dBm</p> <p>Transmit Freq Error: 1.345 kHz</p> <p>x dB Bandwidth: 9.517 MHz</p>		

4.4 Band Edge Measurement

4.4.1 Limits of Band Edge Measurement

For operations in the 699-787 MHz band, the power of any emission outside a licensee's frequency band(s) of operation shall be attenuated below the transmitter power (P) within the licensed band(s) of operation, measured in watts, by at least $43 + 10 \log(P)$ dB. Compliance with this provision is based on the use of measurement instrumentation employing a resolution bandwidth of 100 kilohertz or greater.

However, in the 100 kilohertz bands immediately outside and adjacent to a licensee's frequency block, a resolution bandwidth of at least 30 kHz may be employed.

For operations in the 1710–1755 MHz bands, the power of any emission outside a licensee's frequency block shall be attenuated below the transmitter power (P) by at least $43 + 10 \log_{10}(P)$ dB.

4.4.2 Test Setup

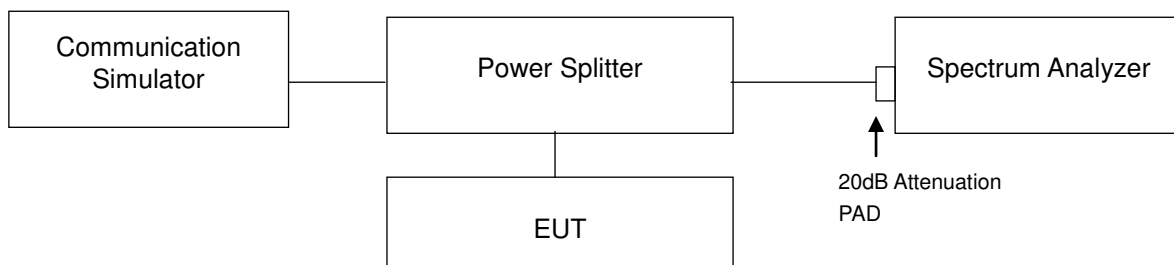

4.4.3 Test Procedures

- All measurements were done at low and high operational frequency range.
- The center frequency of spectrum is the band edge frequency and span is 1 MHz. RB of the spectrum is 100 kHz and VB of the spectrum is 300 kHz (LTE Bandwidth 5 MHz/10 MHz).
- Record the max trace plot into the test report.

4.4.4 Test Results

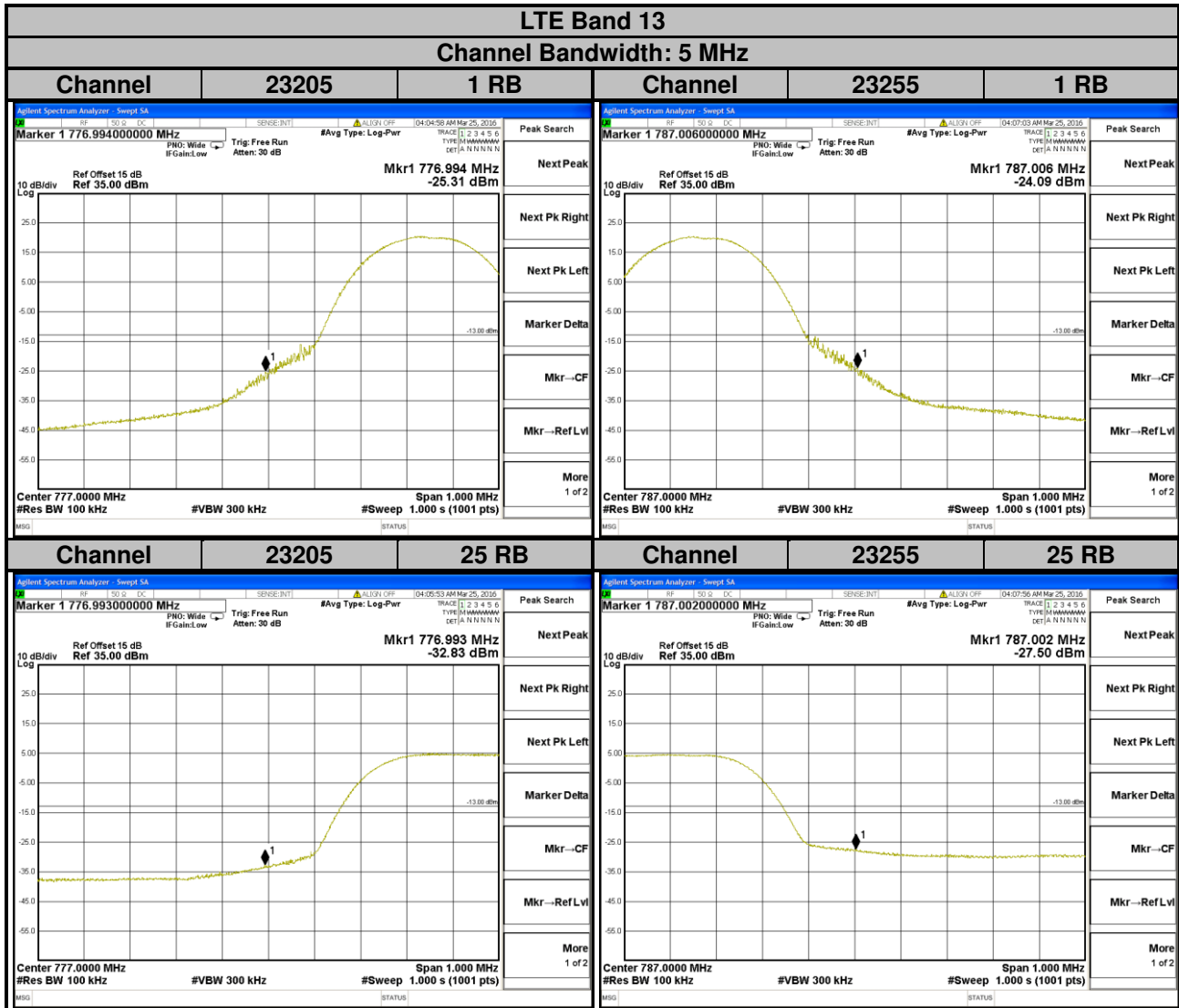



LTE Band 13

Channel Bandwidth: 10 MHz

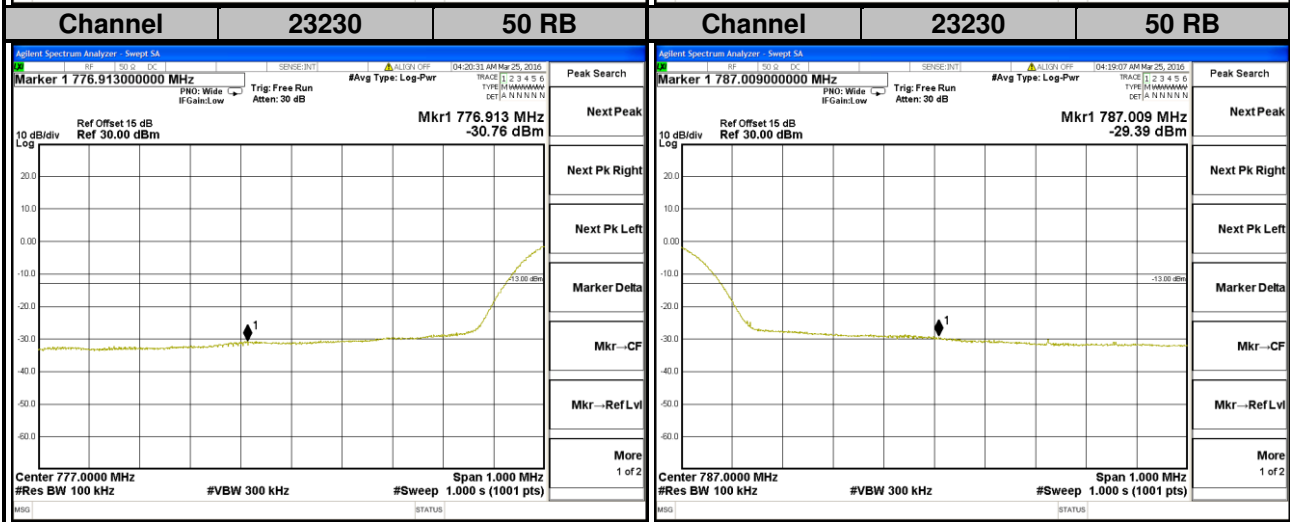
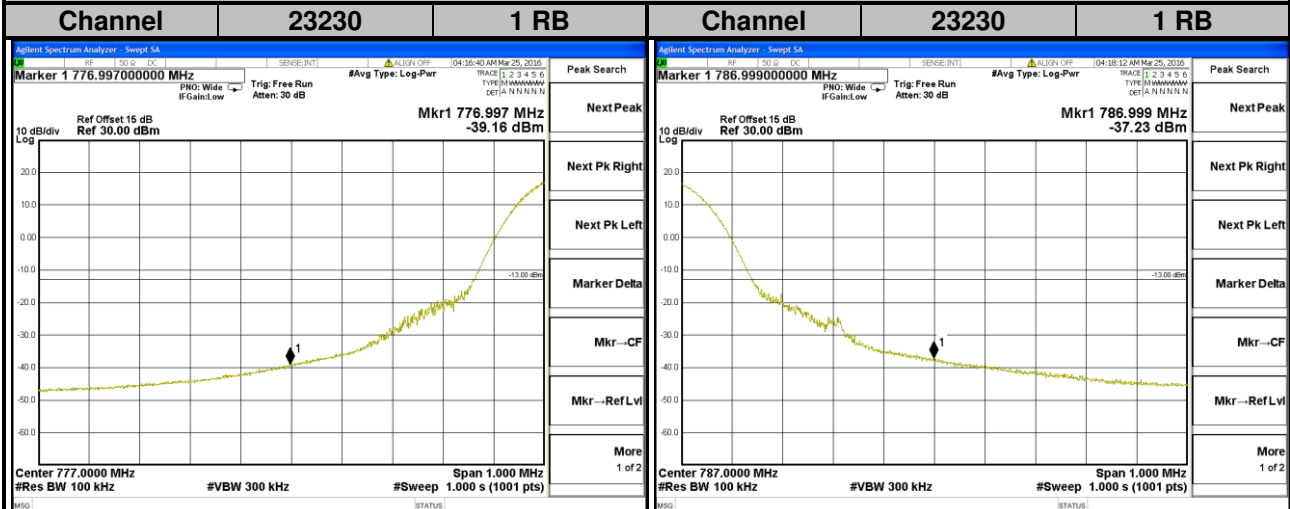



A D T

LTE Band 17

Channel Bandwidth: 5 MHz

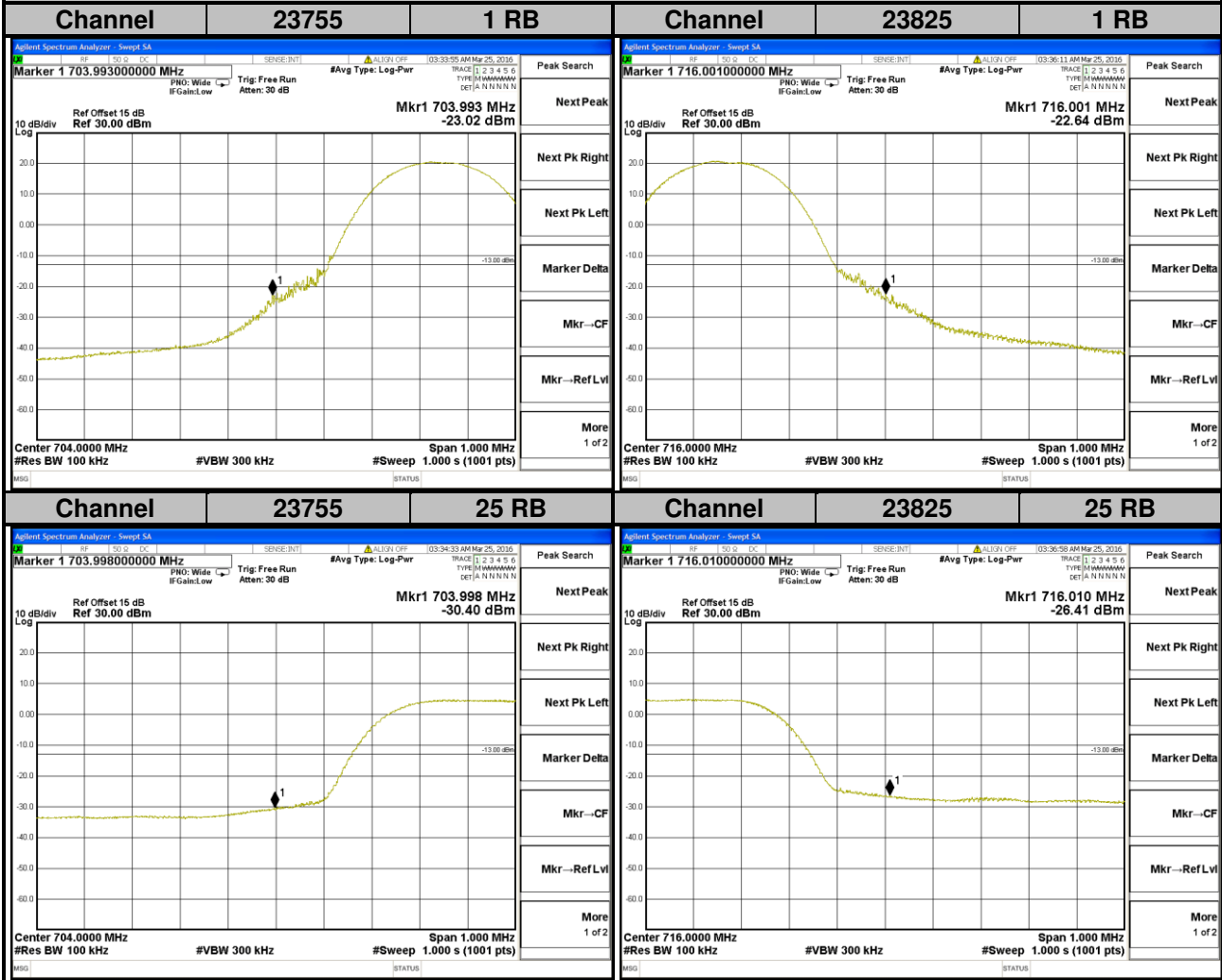



A D T

LTE Band 17

Channel Bandwidth: 10 MHz

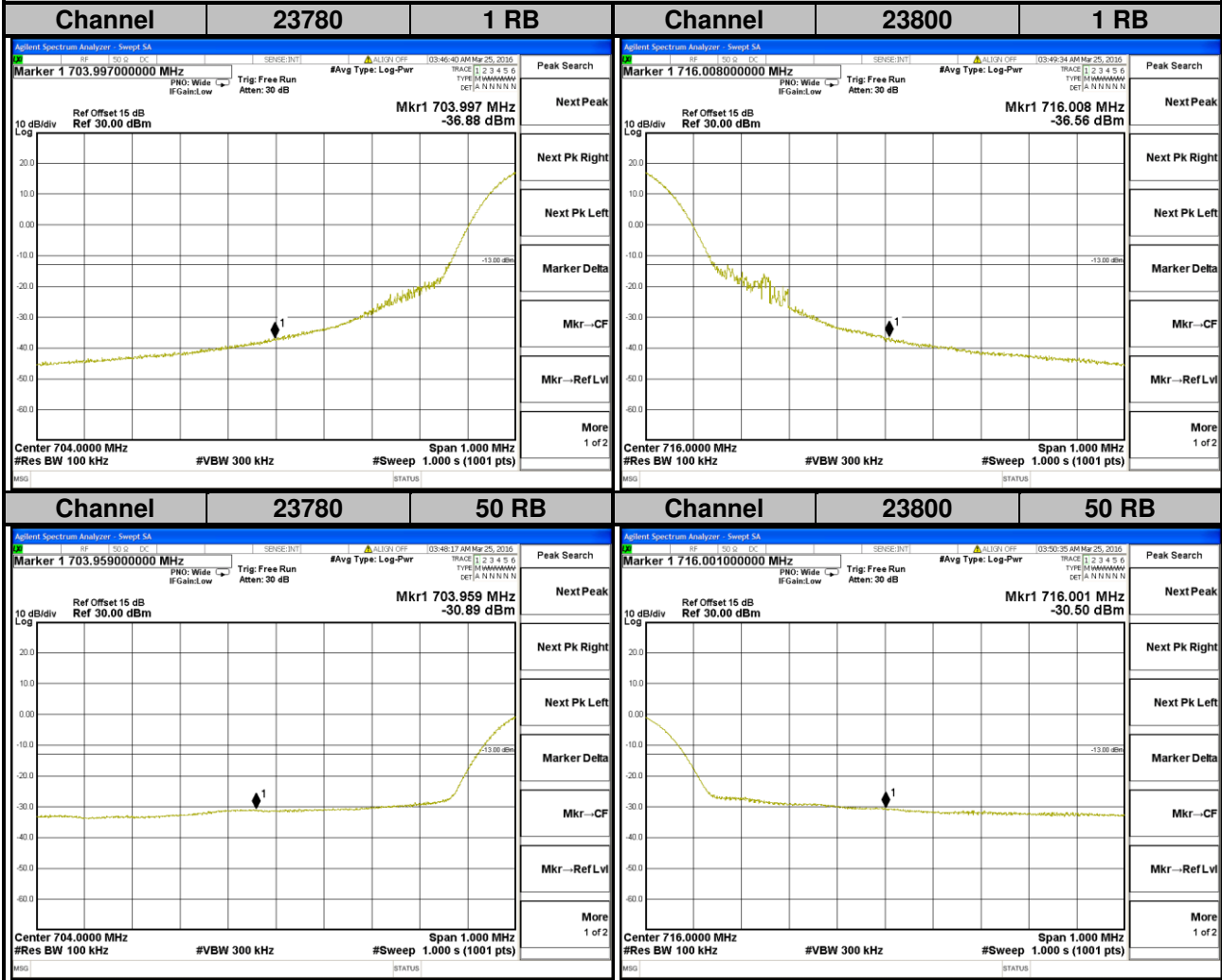

4.5 Peak to Average Ratio

4.5.1 Limits of Peak to Average Ratio Measurement

In measuring transmissions in this band using an average power technique, the peak to-average ratio (PAR) of the transmission may not exceed 13 dB.

4.5.2 Test Setup

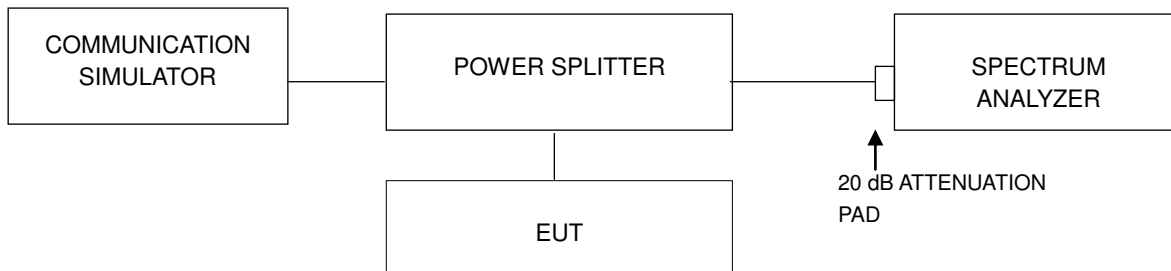

4.5.3 Test Procedures

1. Set resolution/measurement bandwidth \geq signal's occupied bandwidth;
2. Set the number of counts to a value that stabilizes the measured CCDF curve;
3. Record the maximum PAPR level associated with a probability of 0.1 %.

4.5.4 Test Results

LTE Band 13							
Channel Bandwidth: 5 MHz				Channel Bandwidth: 10 MHz			
Channel	Frequency (MHz)	Peak to Average Ratio (dB)		Channel	Frequency (MHz)	Peak to Average Ratio (dB)	
		QPSK	16QAM			QPSK	16QAM
23205	779.5	4.72	5.42	23230	782.0	4.52	5.35
23230	782.0	4.59	5.31				
23255	784.5	4.70	5.44				

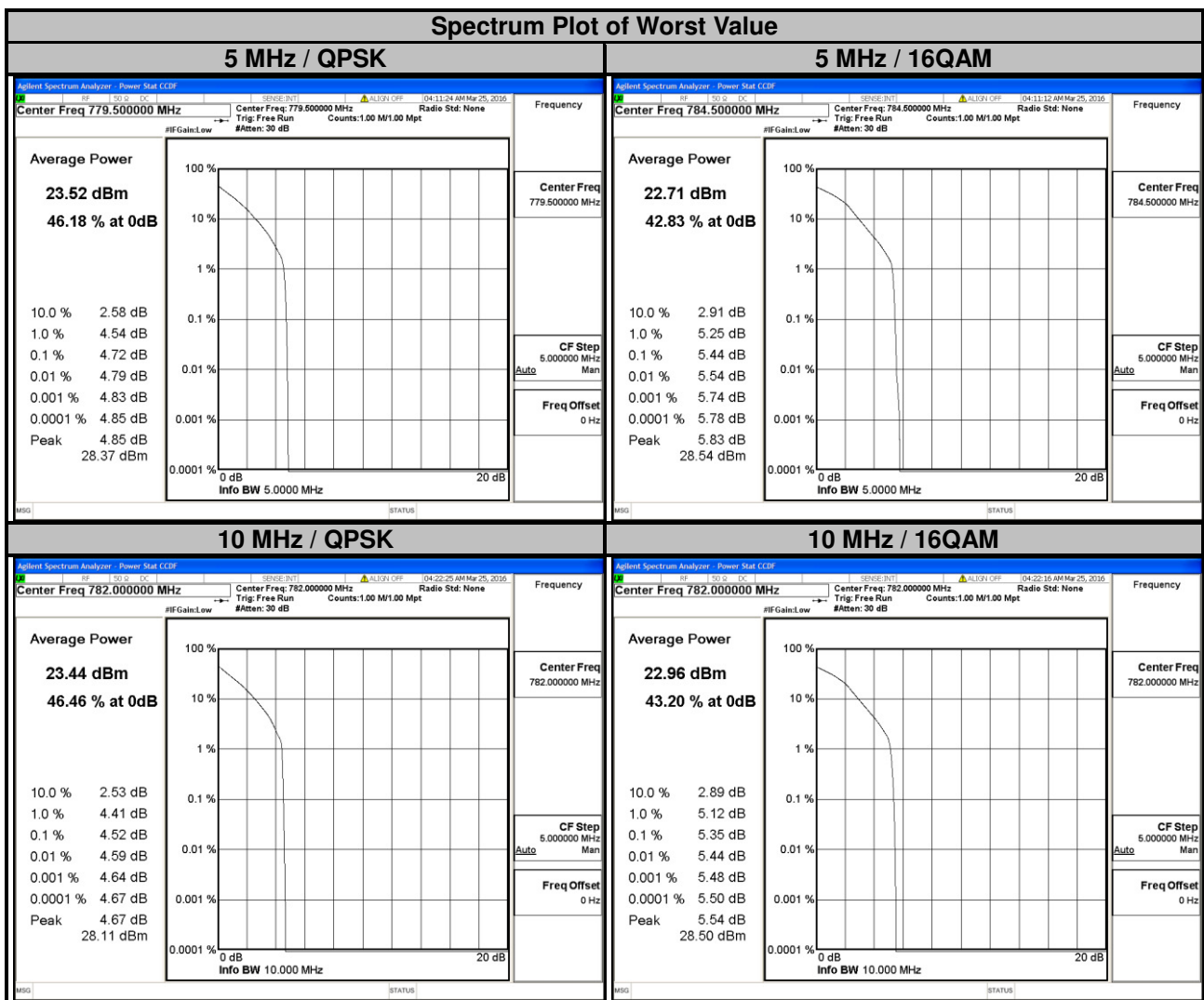



A D T

LTE Band 17

Channel Bandwidth: 5 MHz				Channel Bandwidth: 10 MHz			
Channel	Frequency (MHz)	Peak to Average Ratio (dB)		Channel	Frequency (MHz)	Peak to Average Ratio (dB)	
		QPSK	16QAM			QPSK	16QAM
23755	706.5	4.68	5.40	23780	709.0	4.58	5.24
23790	710.0	4.70	5.43	23790	710.0	4.50	5.24
23825	713.5	4.82	5.54	23800	711.0	4.29	5.12

Spectrum Plot of Worst Value

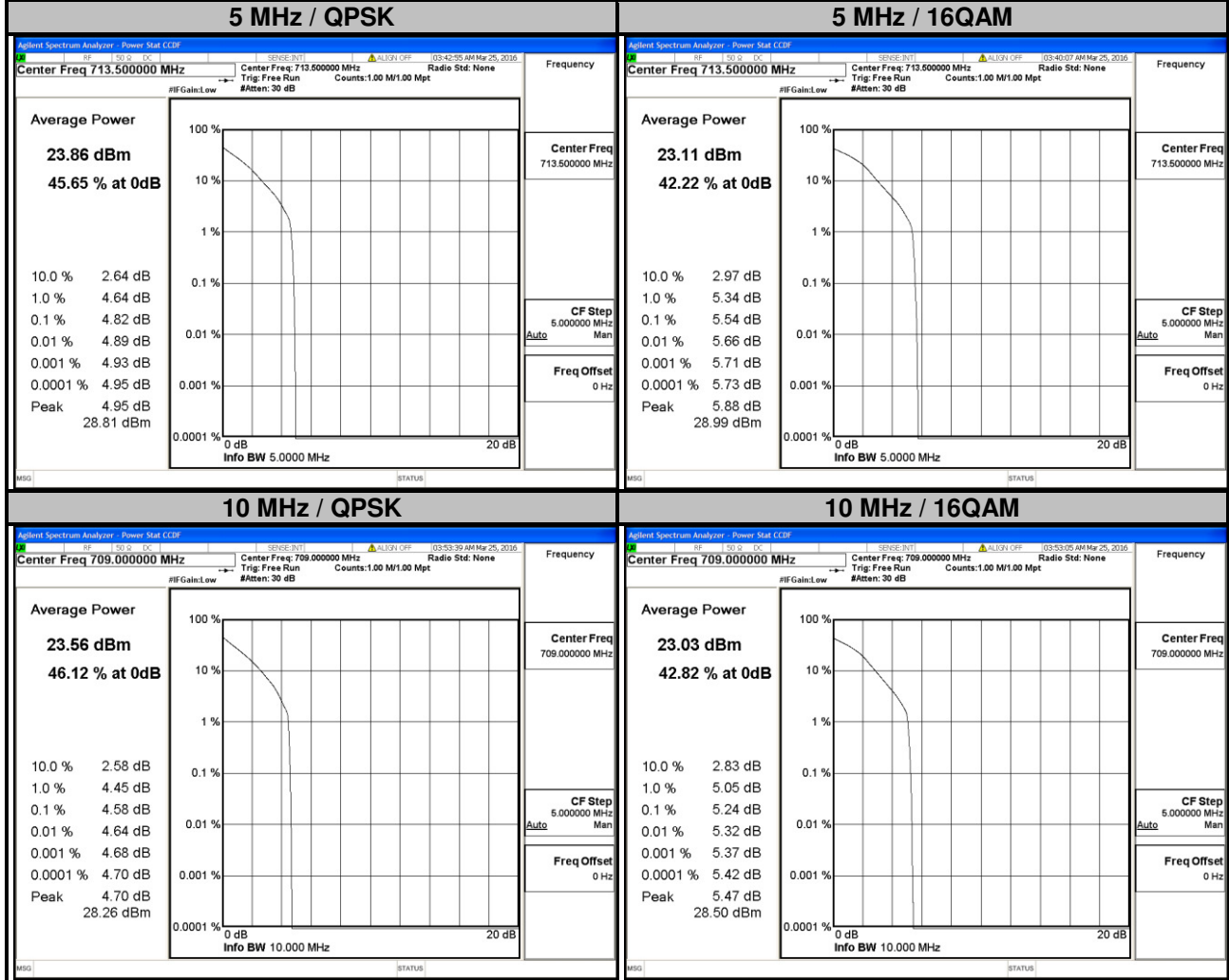

4.6 Conducted Spurious Emissions

4.6.1 Limits of Conducted Spurious Emissions Measurement

The power of any emission outside a licensee's frequency block shall be attenuated below the transmitter power (P) by at least $43 + 10 \log_{10}(P)$ dB. The limit of emission is equal to -13 dBm.

4.6.2 Test Setup

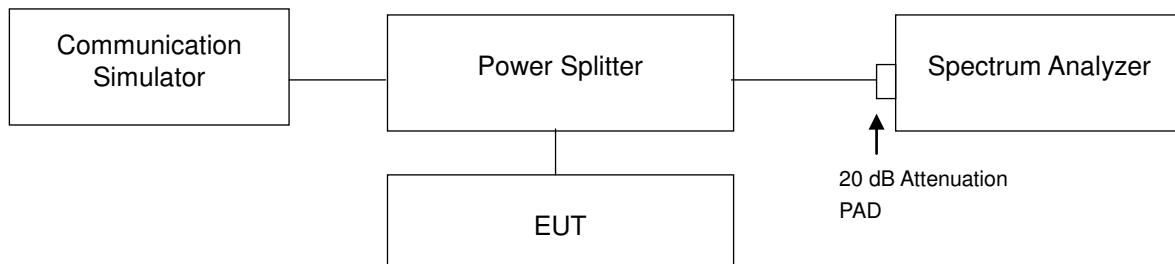

4.6.3 Test Procedure

- The EUT makes a phone call to the communication simulator. All measurements were done at low, middle and high operational frequency range.
- Measuring frequency range is from 30 MHz to 8 GHz. 10 dB attenuation pad is connected with spectrum. RBW=1 MHz and VBW=3 MHz are used for conducted emission measurement.



A D T

4.6.4 Test Results

Frequency Range: 30 MHz ~ 8 GHz

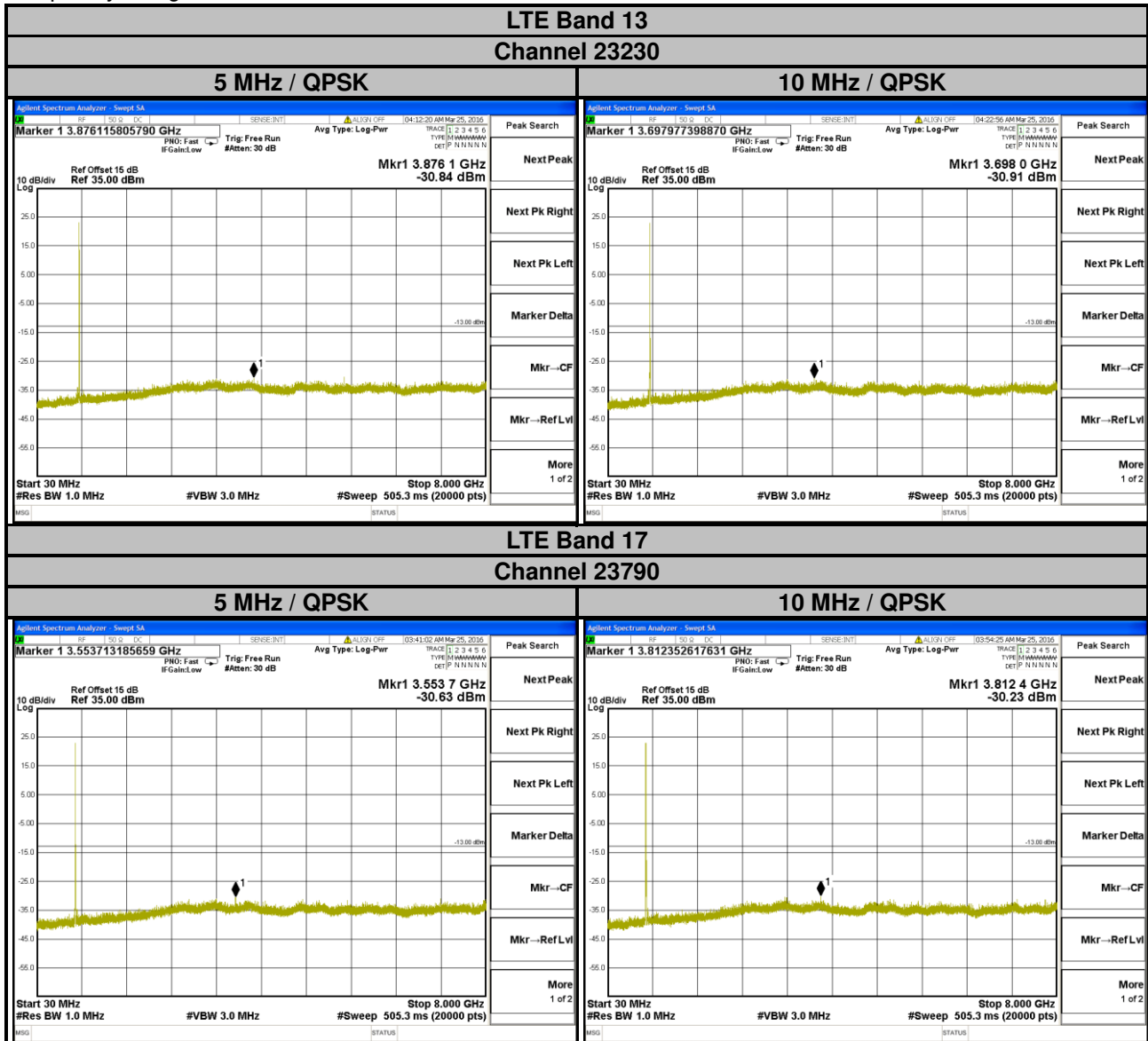

4.7 Radiated Emission Measurement

4.7.1 Limits of Radiated Emission Measurement

The power of any emission outside a licensee's frequency block shall be attenuated below the transmitter power (P) by at least $43 + 10 \log_{10}(P)$ dB. The limit of emission is equal to -13 dBm.

4.7.2 Test Procedure

- Substitution method is used for E.I.R.P measurement. In the semi-anechoic chamber, EUT placed on the 0.8 m height of Turn Table, rotated the table around 360 degrees to search the maximum radiation power and receiver antenna shall be rotated vertical and horizontal polarization and moved height from 1 m to 4 m to find the maximum polar radiated power. The "Read Value" is the spectrum reading the maximum power value.
- The substitution horn antenna is substituted for EUT at the same position and signals generator export the CW signal to the substitution antenna via a TX cable. Rotated the Turn Table and moved receiving antenna to find the maximum radiation power. Adjust output power level of S.G to get a Value of spectrum reading equal to "Read Value" of step a. Record the power level of S.G.
- $EIRP = \text{Output power level of S.G} - \text{TX cable loss} + \text{Antenna gain of substitution horn}$.
- E.R.P power can be calculated form E.I.R.P power by subtracting the gain of dipole, $E.R.P \text{ power} = E.I.P.R \text{ power} - 2.15 \text{ dBi}$.

NOTE: The resolution bandwidth of spectrum analyzer is 1 MHz and the video bandwidth is 3 MHz.

4.7.3 Deviation from Test Standard

No deviation.

4.7.4 Test Setup

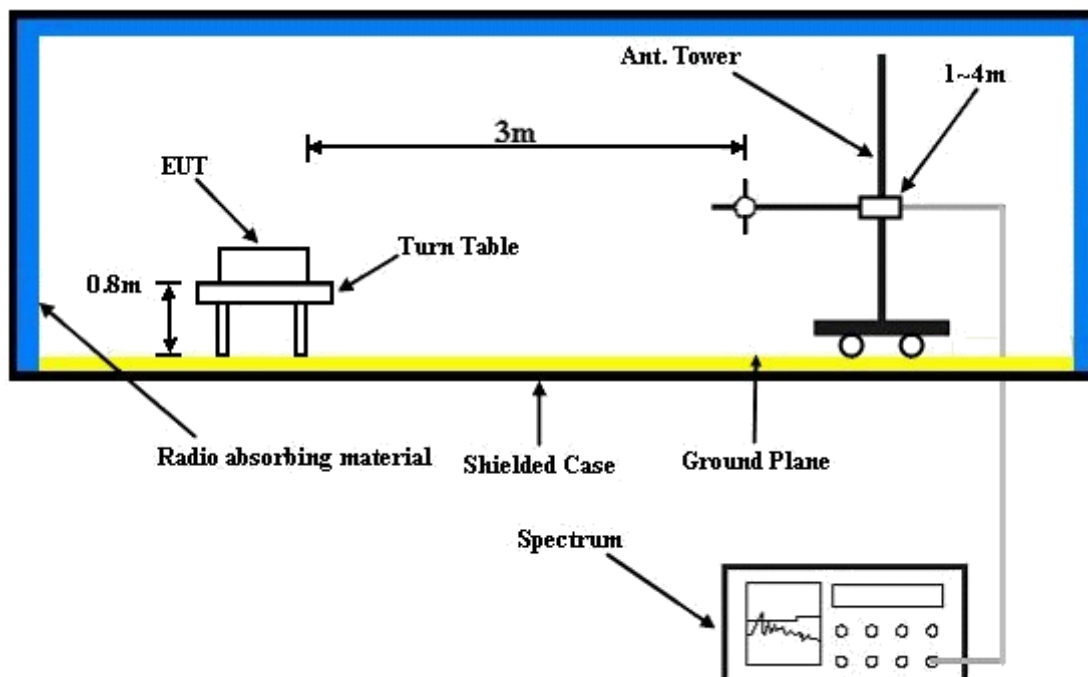

For the actual test configuration, please refer to the attached file (Test Setup Photo).

4.7.5 Test Results

LTE Band 13

Channel Bandwidth: 10 MHz / QPSK



Bureau Veritas Consumer Products Services Ltd., Taoyuan Branch

A D T

Data: 9

Date: 2016-03-17

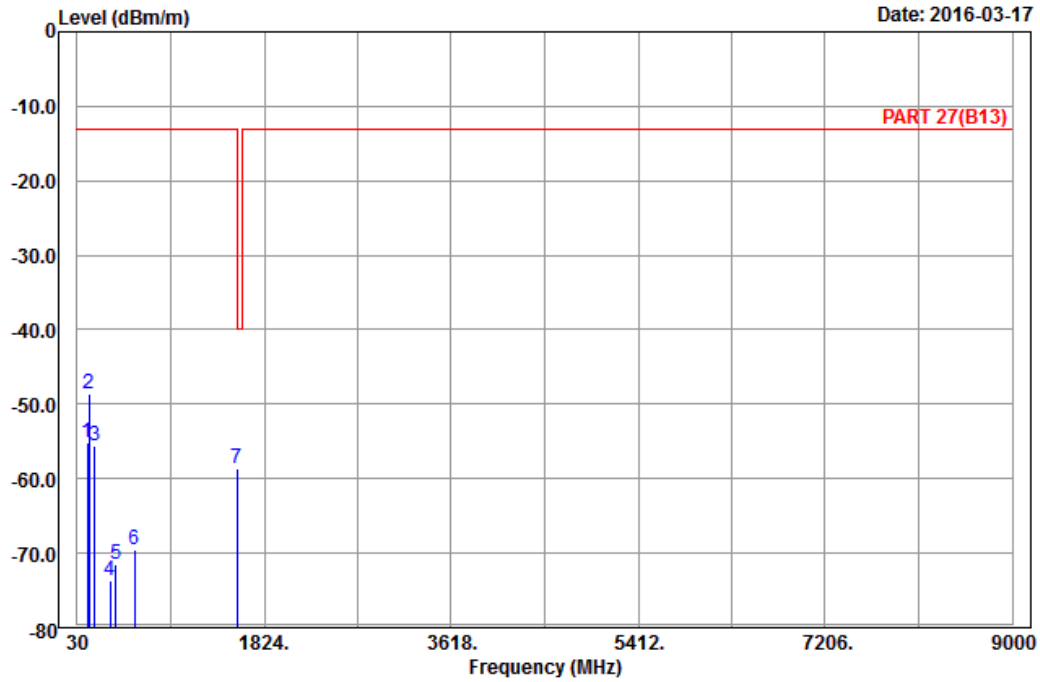

Site : 966 chamber 1
 Condition: PART 27(B13) 3m Horizontal
 Remark : LTE_Band 13_Link_CH23230
 Tested by: Charles Hsiao

	Freq	Level	Read Level	Limit Line	Over Limit	Factor	Remark
	MHz	dBm/m	dBm	dBm/m	dB	dB/m	
1	125.58	-55.15	-47.26	-13.00	-42.15	-7.89	Peak
2	140.70	-48.67	-40.95	-13.00	-35.67	-7.72	Peak
3	196.32	-55.51	-49.51	-13.00	-42.51	-6.00	Peak
4	343.40	-73.73	-68.27	-13.00	-60.73	-5.46	Peak
5	400.10	-71.60	-68.84	-13.00	-58.60	-2.76	Peak
6	578.60	-69.63	-69.17	-13.00	-56.63	-0.46	Peak
7 pp	1564.00	-58.71	-65.57	-40.00	-18.71	6.86	Peak



Bureau Veritas Consumer Products Services Ltd., Taoyuan Branch

A D T

Data: 10

Date: 2016-03-17

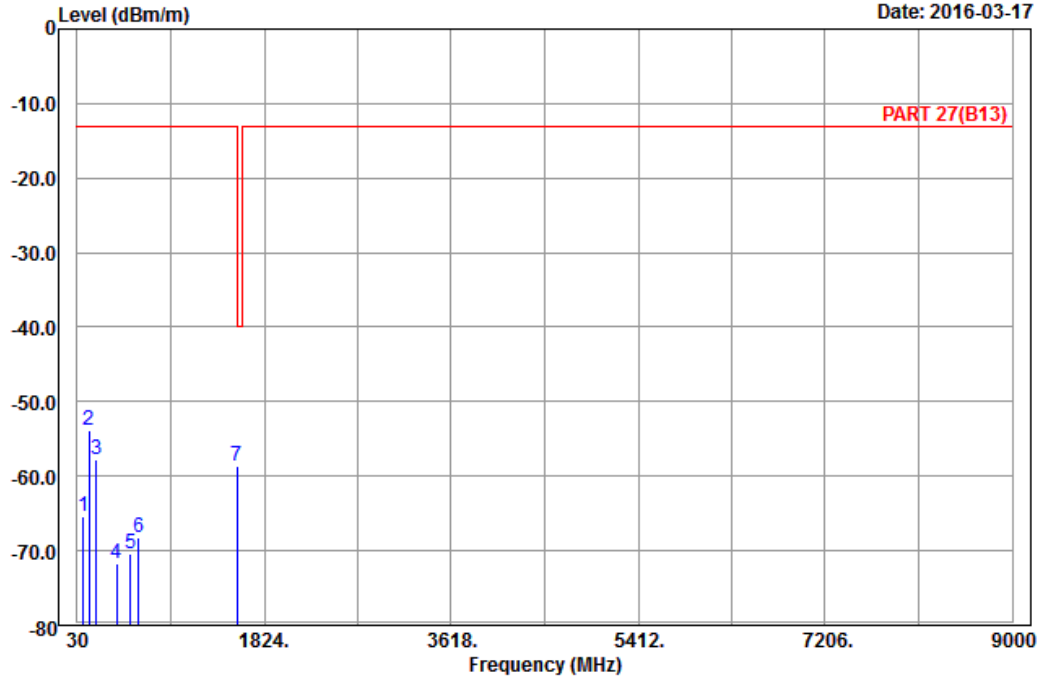

Site : 966 chamber 1
 Condition: PART 27(B13) 3m Vertical
 Remark : LTE_Band 13_Link_CH23230
 Tested by: Charles Hsiao

	Freq	Level	Read Level	Limit Line	Over Limit	Factor	Remark
	MHz	dBm/m	dBm	dBm/m	dB	dB/m	
1	90.21	-65.35	-54.68	-13.00	-52.35	-10.67	Peak
2	144.48	-53.91	-46.10	-13.00	-40.91	-7.81	Peak
3	211.71	-57.69	-51.66	-13.00	-44.69	-6.03	Peak
4	407.80	-71.82	-68.91	-13.00	-58.82	-2.91	Peak
5	539.40	-70.49	-68.05	-13.00	-57.49	-2.44	Peak
6	619.90	-68.18	-68.39	-13.00	-55.18	0.21	Peak
7 pp	1564.00	-58.68	-65.54	-40.00	-18.68	6.86	Peak

LTE Band 17
Channel Bandwidth: 10 MHz / QPSK



Bureau Veritas Consumer Products Services Ltd., Taoyuan Branch

A D T

Data: 9

Date: 2016-03-17

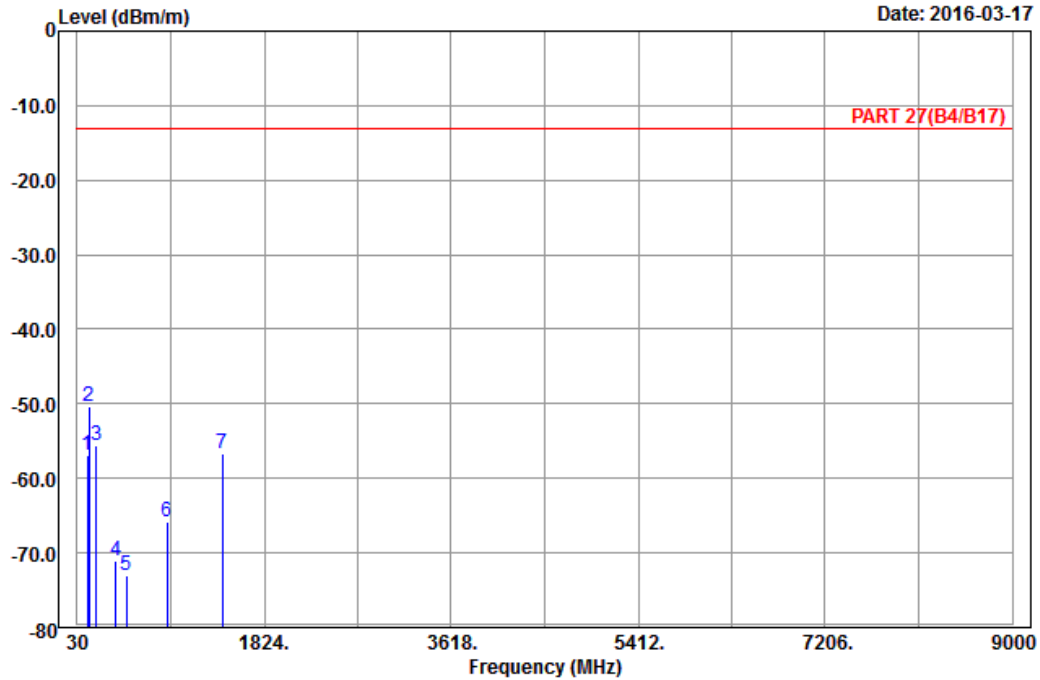

Site : 966 chamber 1
 Condition: PART 27(B4/B17) 3m Horizontal
 Remark : LTE_Band 17_Link_CH23790
 Tested by: Charles Hsiao

	Freq	Level	Read Level	Limit Line	Over Limit	Factor	Remark
	MHz	dBm/m	dBm	dBm/m	dB	dB/m	
1	125.85	-56.99	-49.10	-13.00	-43.99	-7.89	Peak
2	140.43	-50.39	-42.67	-13.00	-37.39	-7.72	Peak
3	212.25	-55.69	-49.68	-13.00	-42.69	-6.01	Peak
4	398.00	-71.07	-68.23	-13.00	-58.07	-2.84	Peak
5	503.70	-72.94	-67.87	-13.00	-59.94	-5.07	Peak
6	894.30	-65.91	-68.63	-13.00	-52.91	2.72	Peak
7	1420.00	-56.76	-63.12	-13.00	-43.76	6.36	Peak



Bureau Veritas Consumer Products Services Ltd., Taoyuan Branch

A D T

Data: 10

Date: 2016-03-17

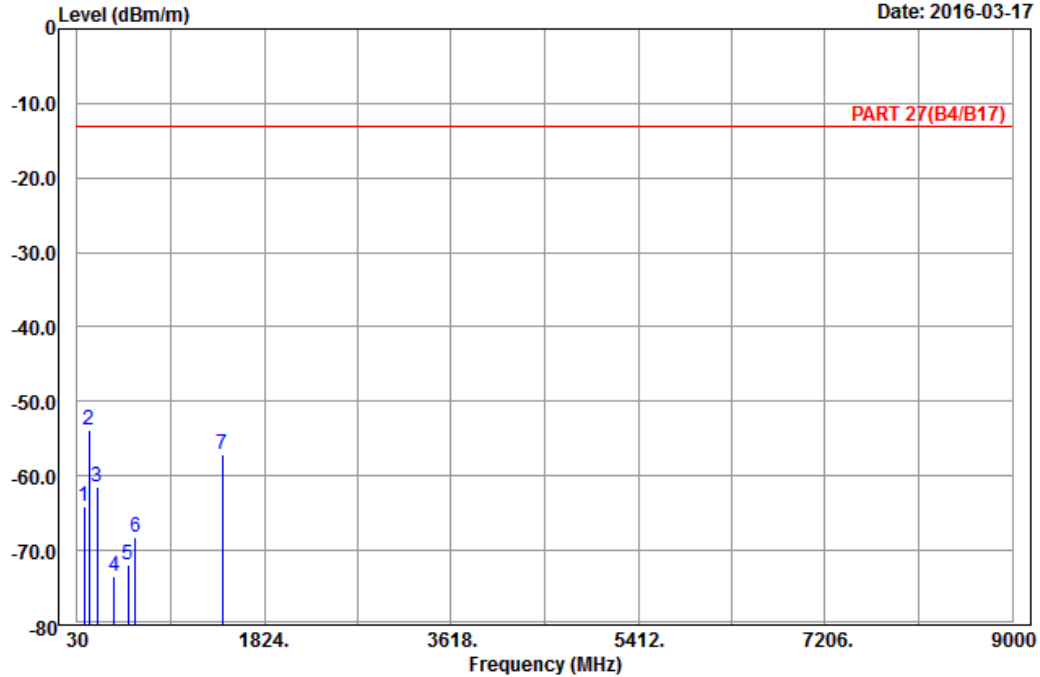

Site : 966 chamber 1
 Condition: PART 27(B4/B17) 3m Vertical
 Remark : LTE_Band 17_Link_CH23790
 Tested by: Charles Hsiao

	Freq	Level	Read Level	Limit Line	Over Limit	Factor	Remark
	MHz	dBm/m	dBm	dBm/m	dB	dB/m	
1	96.15	-64.12	-53.78	-13.00	-51.12	-10.34	Peak
2	pp 144.21	-53.94	-46.13	-13.00	-40.94	-7.81	Peak
3	220.62	-61.41	-55.51	-13.00	-48.41	-5.90	Peak
4	383.30	-73.42	-69.80	-13.00	-60.42	-3.62	Peak
5	514.20	-72.02	-67.73	-13.00	-59.02	-4.29	Peak
6	584.90	-68.18	-67.96	-13.00	-55.18	-0.22	Peak
7	1420.00	-57.11	-63.47	-13.00	-44.11	6.36	Peak



5 Pictures of Test Arrangements

Please refer to the attached file (Test Setup Photo).



A D T

Appendix – Information on the Testing Laboratories

We, Bureau Veritas Consumer Products Services (H.K.) Ltd., Taoyuan Branch, were founded in 1988 to provide our best service in EMC, Radio, Telecom and Safety consultation. Our laboratories are accredited and approved according to ISO/IEC 17025.

If you have any comments, please feel free to contact us at the following:

Linko EMC/RF Lab

Tel: 886-2-26052180

Fax: 886-2-26051924

Hsin Chu EMC/RF/Telecom Lab

Tel: 886-3-6668565

Fax: 886-3-6668323

Hwa Ya EMC/RF/Safety

Tel: 886-3-3183232

Fax: 886-3-3270892

Email: service.adt@tw.bureauveritas.com

Web Site: www.bureauveritas-adt.com

The address and road map of all our labs can be found in our web site also.

--- END ---