



FCC TEST REPORT (15.247)

REPORT NO.: RF140324C25-1
MODEL NO.: 0PAJ500
FCC ID: NM80PAJ500
RECEIVED: Mar. 24, 2014
TESTED: Apr. 19, 2014 ~ Apr. 24, 2014
ISSUED: Jun. 04, 2014

APPLICANT: HTC Corporation

ADDRESS: 1F, 6-3 Baoqiang Road, Xindian District, New Taipei City, Taiwan 231

ISSUED BY: Bureau Veritas Consumer Products Services (H.K.) Ltd., Taoyuan Branch

LAB ADDRESS: No. 47, 14th Ling, Chia Pau Vil., Lin Kou Dist., New Taipei City, Taiwan (R.O.C)

TEST LOCATION: No. 19, Hwa Ya 2nd Rd, Wen Hwa Tsuen, Kwei Shan Hsiang, Taoyuan Hsien 333, Taiwan, R.O.C.

This report should not be used by the client to claim product certification, approval, or endorsement by TAF or any government agencies.



This report is for your exclusive use. Any copying or replication of this report to or for any other person or entity, or use of our name or trademark, is permitted only with our prior written permission. This report sets forth our findings solely with respect to the test samples identified herein. The results set forth in this report are not indicative or representative of the quality or characteristics of the lot from which a test sample was taken or any similar or identical product unless specifically and expressly noted. Our report includes all of the tests requested by you and the results thereof based upon the information that you provided to us. You have 60 days from date of issuance of this report to notify us of any material error or omission caused by our negligence, provided, however, that such notice shall be in writing and shall specifically address the issue you wish to raise. A failure to raise such issue within the prescribed time shall constitute your unqualified acceptance of the completeness of this report, the tests conducted and the correctness of the report contents. Unless specific mention, the uncertainty of measurement has been explicitly taken into account to declare the compliance or non-compliance to the specification.



TABLE OF CONTENTS

- RELEASE CONTROL RECORD5
- 1. CERTIFICATION.....6
- 2. SUMMARY OF TEST RESULTS7
 - 2.1 MEASUREMENT UNCERTAINTY.....7
- 3. GENERAL INFORMATION8
 - 3.1 GENERAL DESCRIPTION OF EUT8
 - 3.2 DESCRIPTION OF TEST MODES9
 - 3.2.1 TEST MODE APPLICABILITY AND TESTED CHANNEL DETAIL 10
 - 3.3 DESCRIPTION OF SUPPORT UNITS 14
 - 3.3.1 CONFIGURATION OF SYSTEM UNDER TEST 14
 - 3.4 DUTY CYCLE TEST SIGNAL 15
 - 3.5 GENERAL DESCRIPTION OF APPLIED STANDARDS 17
- 4. TEST TYPES AND RESULTS (FOR 2.4GHz BAND) 18
 - 4.1 RADIATED EMISSION AND BANDEDGE MEASUREMENT 18
 - 4.1.1 LIMITS OF RADIATED EMISSION AND BANDEDGE MEASUREMENT 18
 - 4.1.2 TEST INSTRUMENTS 19
 - 4.1.3 TEST PROCEDURES 20
 - 4.1.4 DEVIATION FROM TEST STANDARD 20
 - 4.1.5 TEST SETUP 21
 - 4.1.6 EUT OPERATING CONDITIONS 22
 - 4.1.7 TEST RESULTS..... 23
 - 4.2 CONDUCTED EMISSION MEASUREMENT 34
 - 4.2.1 LIMITS OF CONDUCTED EMISSION MEASUREMENT 34
 - 4.2.2 TEST INSTRUMENTS 34
 - 4.2.3 TEST PROCEDURES 35
 - 4.2.4 DEVIATION FROM TEST STANDARD 35
 - 4.2.5 TEST SETUP 36
 - 4.2.6 EUT OPERATING CONDITIONS 36
 - 4.2.7 TEST RESULTS..... 37
 - 4.3 6dB BANDWIDTH MEASUREMENT 41
 - 4.3.1 LIMITS OF 6dB BANDWIDTH MEASUREMENT 41
 - 4.3.2 TEST SETUP 41
 - 4.3.3 TEST INSTRUMENTS 41
 - 4.3.4 TEST PROCEDURE 41
 - 4.3.5 DEVIATION FROM TEST STANDARD 41
 - 4.3.6 EUT OPERATING CONDITIONS 41
 - 4.3.7 TEST RESULTS..... 42
 - 4.4 CONDUCTED OUTPUT POWER 44
 - 4.4.1 LIMITS OF CONDUCTED OUTPUT POWER MEASUREMENT 44
 - 4.4.2 TEST SETUP 44
 - 4.4.3 TEST INSTRUMENTS 44
 - 4.4.4 TEST PROCEDURES 44
 - 4.4.5 DEVIATION FROM TEST STANDARD 44
 - 4.4.6 EUT OPERATING CONDITIONS 44
 - 4.4.7 TEST RESULTS..... 45
 - 4.5 POWER SPECTRAL DENSITY MEASUREMENT 46
 - 4.5.1 LIMITS OF POWER SPECTRAL DENSITY MEASUREMENT 46
 - 4.5.2 TEST SETUP 46
 - 4.5.3 TEST INSTRUMENTS 46
 - 4.5.4 TEST PROCEDURE 46
 - 4.5.5 DEVIATION FROM TEST STANDARD 46
 - 4.5.6 EUT OPERATING CONDITION..... 46



4.5.7	TEST RESULTS.....	47
4.6	CONDUCTED OUT OF BAND EMISSION MEASUREMENT	49
4.6.1	LIMITS OF CONDUCTED OUT OF BAND EMISSION MEASUREMENT	49
4.6.2	TEST SETUP	49
4.6.3	TEST INSTRUMENTS	49
4.6.4	TEST PROCEDURE	49
4.6.5	DEVIATION FROM TEST STANDARD	49
4.6.6	EUT OPERATING CONDITION.....	49
4.6.7	TEST RESULTS.....	50
5.	TEST TYPES AND RESULTS (FOR 5.0GHz BAND)	53
5.1	RADIATED EMISSION AND BANDEDGE MEASUREMENT	53
5.1.1	LIMITS OF RADIATED EMISSION AND BANDEDGE MEASUREMENT	53
5.1.2	TEST INSTRUMENTS.....	54
5.1.3	TEST PROCEDURES	54
5.1.4	DEVIATION FROM TEST STANDARD	54
5.1.5	TEST SETUP	54
5.1.6	EUT OPERATING CONDITIONS	54
5.1.7	TEST RESULTS.....	55
5.2	CONDUCTED EMISSION MEASUREMENT	65
5.2.1	LIMITS OF CONDUCTED EMISSION MEASUREMENT	65
5.2.2	TEST INSTRUMENTS	65
5.2.3	TEST PROCEDURES	65
5.2.4	DEVIATION FROM TEST STANDARD	65
5.2.5	TEST SETUP	65
5.2.6	EUT OPERATING CONDITIONS	65
5.2.7	TEST RESULTS.....	66
5.3	6dB BANDWIDTH MEASUREMENT	70
5.3.1	LIMITS OF 6dB BANDWIDTH MEASUREMENT	70
5.3.2	TEST SETUP	70
5.3.3	TEST INSTRUMENTS.....	70
5.3.4	TEST PROCEDURE	70
5.3.5	DEVIATION FROM TEST STANDARD	70
5.3.6	EUT OPERATING CONDITIONS	70
5.3.7	TEST RESULTS.....	71
5.4	MAXIMUM OUTPUT POWER	73
5.4.1	LIMITS OF MAXIMUM OUTPUT POWER MEASUREMENT	73
5.4.2	TEST SETUP	73
5.4.3	INSTRUMENTS	73
5.4.4	TEST PROCEDURES	73
5.4.5	DEVIATION FROM TEST STANDARD	73
5.4.6	EUT OPERATING CONDITIONS	73
5.4.7	TEST RESULTS.....	74
5.5	POWER SPECTRAL DENSITY MEASUREMENT.....	75
5.5.1	LIMITS OF POWER SPECTRAL DENSITY MEASUREMENT	75
5.5.2	TEST SETUP	75
5.5.3	TEST INSTRUMENTS.....	75
5.5.4	TEST PROCEDURE	75
5.5.5	DEVIATION FROM TEST STANDARD	75
5.5.6	EUT OPERATING CONDITION.....	75
5.5.7	TEST RESULTS.....	76
5.6	CONDUCTED OUT OF BAND EMISSION MEASUREMENT	78
5.6.1	LIMITS OF OUT OF BAND EMISSION MEASUREMENT	78
5.6.2	TEST SETUP	78
5.6.3	TEST INSTRUMENTS.....	78
5.6.4	TEST PROCEDURE	78



A D T

5.6.5	DEVIATION FROM TEST STANDARD	78
5.6.6	EUT OPERATING CONDITION.....	78
5.6.7	TEST RESULTS.....	78
6.	PHOTOGRAPHS OF THE TEST CONFIGURATION.....	82
7.	INFORMATION ON THE TESTING LABORATORIES	83
8.	APPENDIX A – MODIFICATIONS RECORDERS FOR ENGINEERING CHANGES TO THE EUT BY THE LAB	84



A D T

RELEASE CONTROL RECORD

ISSUE NO.	REASON FOR CHANGE	DATE ISSUED
RF140324C25-1	Original release	Jun. 04, 2014

1. CERTIFICATION

PRODUCT: Smartphone
MODEL NO.: 0PAJ500
BRAND: HTC
APPLICANT: HTC Corporation
TESTED: Apr. 19, 2014 ~ Apr. 24, 2014
TEST SAMPLE: Production Unit
STANDARDS: **FCC Part 15, Subpart C (Section 15.247)**
ANSI C63.10-2009

The above equipment (model: 0PAJ500) has been tested by **Bureau Veritas Consumer Products Services (H.K.) Ltd., Taoyuan Branch**, and found compliance with the requirement of the above standards. The test record, data evaluation & Equipment Under Test (EUT) configurations represented herein are true and accurate accounts of the measurements of the sample's EMC characteristics under the conditions specified in this report.

PREPARED BY : Ivonne Wu , **DATE** : Jun. 04, 2014
Ivonne Wu / Supervisor

APPROVED BY : Sam Chen , **DATE** : Jun. 04, 2014
Sam Chen / Senior Project Engineer

2. SUMMARY OF TEST RESULTS

The EUT has been tested according to the following specifications:

APPLIED STANDARD: FCC PART 15, SUBPART C (SECTION 15.247)			
STANDARD SECTION	TEST TYPE	RESULT	REMARK
15.207	AC Power Conducted Emission	PASS	Meet the requirement of limit. Minimum passing margin is -3.03dB at 13.56250MHz.
15.205 & 15.209	Radiated Emissions	PASS	Meet the requirement of limit. Minimum passing margin is -3.03dB at 2484.00MHz.
15.247(d)	Band Edge Measurement	PASS	Meet the requirement of limit.
15.247(d)	Antenna Port Emission	PASS	Meet the requirement of limit.
15.247(a)(2)	6dB bandwidth	PASS	Meet the requirement of limit.
15.247(b)	Conducted power	PASS	Meet the requirement of limit.
15.247(e)	Power Spectral Density	PASS	Meet the requirement of limit.
15.203	Antenna Requirement	PASS	No antenna connector is used.

2.1 MEASUREMENT UNCERTAINTY

Where relevant, the following measurement uncertainty levels have been estimated for tests performed on the EUT as specified in CISPR 16-4-2:

MEASUREMENT	FREQUENCY	UNCERTAINTY
Conducted emissions	9kHz~30MHz	2.44 dB
Radiated emissions	30MHz ~ 200MHz	2.93 dB
	200MHz ~1000MHz	2.95 dB
	1GHz ~ 18GHz	2.26 dB
	18GHz ~ 40GHz	1.94 dB

This uncertainty represents an expanded uncertainty expressed at approximately the 95% confidence level using a coverage factor of $k = 2$.

3. GENERAL INFORMATION

3.1 GENERAL DESCRIPTION OF EUT

EUT	Smartphone
MODEL NO.	0PAJ500
POWER SUPPLY	5.0Vdc (adapter or host equipment) 3.8Vdc (Li-ion battery)
MODULATION TYPE	CCK, DQPSK, DBPSK for DSSS 64QAM, 16QAM, QPSK, BPSK for OFDM
MODULATION TECHNOLOGY	DSSS, OFDM
TRANSFER RATE	802.11b: 11.0 / 5.5 / 2.0 / 1.0 Mbps 802.11g: 54.0 / 48.0 / 36.0 / 24.0 / 18.0 / 12.0 / 9.0 / 6.0 Mbps 802.11a: 54.0 / 48.0 / 36.0 / 24.0 / 18.0 / 12.0 / 9.0 / 6.0 Mbps 802.11n: up to MCS7
OPERATING FREQUENCY	2.4GHz: 2412 ~ 2462MHz 5.0GHz: 5745 ~ 5805MHz
NUMBER OF CHANNEL	2.4GHz: 11 for 802.11b, 802.11g, 802.11n (20MHz) 5.0GHz: 4 for 802.11a, 802.11n (20MHz) 2 for 802.11n (40MHz)
OUTPUT POWER	220.29mW for 2412 ~ 2462MHz 308.32mW for 5745 ~ 5805/5825MHz
ANTENNA TYPE	2.4GHz: PIFA antenna with -1dBi gain 5.0GHz: PIFA antenna with -3.5dBi gain
ANTENNA CONNECTOR	NA
DATA CABLE	Refer to Note as below
I/O PORTS	Refer to user's manual
ACCESSORY DEVICES	Refer to Note as below

NOTE:

- The EUT's accessories list refers to Ext. Pho.
- There're 2 configurations for the EUT listed as below.
Main sample (A): Phone + Battery 1 + LCM 1
2nd sample (B): Phone + Battery 2 + LCM 2
❖ Only the worst test data was presented in the report.
- The above EUT information is declared by the manufacturer and for more detailed features description, please refer to the manufacturer's specifications or User's Manual.

3.2 DESCRIPTION OF TEST MODES

FOR 2.4GHz:

11 channels are provided for 802.11b, 802.11g and 802.11n (20MHz):

CHANNEL	FREQUENCY	CHANNEL	FREQUENCY
1	2412MHz	7	2442MHz
2	2417MHz	8	2447MHz
3	2422MHz	9	2452MHz
4	2427MHz	10	2457MHz
5	2432MHz	11	2462MHz
6	2437MHz		

FOR 5.0GHz (5745 ~ 5805MHz):

5 channels are provided for 802.11a, 802.11n (20MHz):

CHANNEL	FREQUENCY	CHANNEL	FREQUENCY
149	5745MHz	157	5785MHz
153	5765MHz	161	5805MHz

2 channels are provided for 802.11n (40MHz):

CHANNEL	FREQUENCY	CHANNEL	FREQUENCY
151	5755MHz	159	5795MHz



A D T

3.2.1 TEST MODE APPLICABILITY AND TESTED CHANNEL DETAIL

WLAN 2.4GHz:

EUT CONFIGURE MODE	APPLICABLE TO				DESCRIPTION
	RE≥1G	RE<1G	PLC	APCM	
A	√	√	√	√	Main sample
B	√	-	√	-	2 nd sample

Where **RE≥1G**: Radiated Emission above 1GHz **RE<1G**: Radiated Emission below 1GHz
PLC: Power Line Conducted Emission **APCM**: Antenna Port Conducted Measurement

NOTE: The EUT had been pre-tested on the positioned of each 3 axis. The worst case was found when positioned on **Z-plane**.

RADIATED EMISSION TEST (ABOVE 1GHz):

Pre-Scan has been conducted to determine the worst-case mode from all possible combinations between available modulations, data rates and antenna ports (if EUT with antenna diversity architecture).

Following channel(s) was (were) selected for the final test as listed below.

EUT CONFIGURE MODE	MODE	AVAILABLE CHANNEL	TESTED CHANNEL	MODULATION TECHNOLOGY	MODULATION TYPE	DATA RATE (Mbps)
A	802.11b	1 to 11	1, 6, 11	DSSS	DBPSK	1.0
	802.11g	1 to 11	1, 6, 11	OFDM	BPSK	6.0
	802.11n (20MHz)	1 to 11	1, 6, 11	OFDM	BPSK	MCS0
B	802.11g	1 to 11	11	OFDM	BPSK	MCS0

RADIATED EMISSION TEST (BELOW 1GHz):

Pre-Scan has been conducted to determine the worst-case mode from all possible combinations between available modulations, data rates and antenna ports (if EUT with antenna diversity architecture).

Following channel(s) was (were) selected for the final test as listed below.

EUT CONFIGURE MODE	MODE	AVAILABLE CHANNEL	TESTED CHANNEL	MODULATION TECHNOLOGY	MODULATION TYPE	DATA RATE (Mbps)
A	802.11g	1 to 11	11	OFDM	BPSK	6.0

POWER LINE CONDUCTED EMISSION TEST:

EUT CONFIGURE MODE	MODE	AVAILABLE CHANNEL	TESTED CHANNEL	MODULATION TECHNOLOGY	MODULATION TYPE	DATA RATE (Mbps)
A, B	802.11g	1 to 11	11	OFDM	BPSK	6.0



A D T

BANDEDGE MEASUREMENT:

- Pre-Scan has been conducted to determine the worst-case mode from all possible combinations between available modulations, data rates and antenna ports (if EUT with antenna diversity architecture).
- Following channel(s) was (were) selected for the final test as listed below.

EUT CONFIGURE MODE	MODE	AVAILABLE CHANNEL	TESTED CHANNEL	MODULATION TECHNOLOGY	MODULATION TYPE	DATA RATE (Mbps)
A	802.11b	1 to 11	1, 6, 11	DSSS	DBPSK	1.0
	802.11g	1 to 11	1, 6, 11	OFDM	BPSK	6.0
	802.11n (20MHz)	1 to 11	1, 6, 11	OFDM	BPSK	MCS0

ANTENNA PORT CONDUCTED MEASUREMENT:

- This item includes all test value of each mode, but only includes spectrum plot of worst value of each mode.
- Pre-Scan has been conducted to determine the worst-case mode from all possible combinations between available modulations, data rates and antenna ports (if EUT with antenna diversity architecture).
- Following channel(s) was (were) selected for the final test as listed below.

EUT CONFIGURE MODE	MODE	AVAILABLE CHANNEL	TESTED CHANNEL	MODULATION TECHNOLOGY	MODULATION TYPE	DATA RATE (Mbps)
A	802.11b	1 to 11	1, 6, 11	DSSS	DBPSK	1.0
	802.11g	1 to 11	1, 6, 11	OFDM	BPSK	6.0
	802.11n (20MHz)	1 to 11	1, 6, 11	OFDM	BPSK	MCS0

Test CONDITION:

APPLICABLE TO	ENVIRONMENTAL CONDITIONS	INPUT POWER	TESTED BY
RE \geq 1G	25deg. C, 65%RH	120Vac, 60Hz	Johnson Liao
RE $<$ 1G	25deg. C, 65%RH	120Vac, 60Hz	Johnson Liao
PLC	25deg. C, 65%RH	120Vac, 60Hz	Peter Weng
APCM	25deg. C, 65%RH	120Vac, 60Hz	Howard Kao



A D T

WLAN 5.0GHz (5745 ~ 5805MHz):

EUT CONFIGURE MODE	APPLICABLE TO				DESCRIPTION
	RE≥1G	RE<1G	PLC	APCM	
A	√	√	√	√	Main sample
B	√	-	√	-	2 nd sample

Where **RE≥1G**: Radiated Emission above 1GHz **RE<1G**: Radiated Emission below 1GHz
PLC: Power Line Conducted Emission **APCM**: Antenna Port Conducted Measurement

NOTE: The EUT had been pre-tested on the positioned of each 3 axis. The worst case was found when positioned on **X-plane**.

RADIATED EMISSION TEST (ABOVE 1GHz):

- Pre-Scan has been conducted to determine the worst-case mode from all possible combinations between available modulations, data rates and antenna ports (if EUT with antenna diversity architecture).
- Following channel(s) was (were) selected for the final test as listed below.

EUT CONFIGURE MODE	MODE	AVAILABLE CHANNEL	TESTED CHANNEL	MODULATION TECHNOLOGY	MODULATION TYPE	DATA RATE (Mbps)
A	802.11a	149 to 161	149, 157, 161	OFDM	BPSK	6.0
	802.11n (20MHz)	149 to 161	149, 157, 161	OFDM	BPSK	MCS0
	802.11n (40MHz)	151 to 159	151, 159	OFDM	BPSK	MCS0
B	802.11n (40MHz)	151 to 159	159	OFDM	BPSK	MCS0

RADIATED EMISSION TEST (BELOW 1GHz):

- Pre-Scan has been conducted to determine the worst-case mode from all possible combinations between available modulations, data rates and antenna ports (if EUT with antenna diversity architecture).
- Following channel(s) was (were) selected for the final test as listed below.

EUT CONFIGURE MODE	MODE	AVAILABLE CHANNEL	TESTED CHANNEL	MODULATION TECHNOLOGY	MODULATION TYPE	DATA RATE (Mbps)
A	802.11n (40MHz)	151 to 159	159	OFDM	BPSK	MCS0

POWER LINE CONDUCTED EMISSION TEST:

EUT CONFIGURE MODE	MODE	AVAILABLE CHANNEL	TESTED CHANNEL	MODULATION TECHNOLOGY	MODULATION TYPE	DATA RATE (Mbps)
A, B	802.11n (40MHz)	151 to 159	159	OFDM	BPSK	MCS0



A D T

BANDEDGE MEASUREMENT:

- Pre-Scan has been conducted to determine the worst-case mode from all possible combinations between available modulations, data rates and antenna ports (if EUT with antenna diversity architecture).
- Following channel(s) was (were) selected for the final test as listed below.

EUT CONFIGURE MODE	MODE	AVAILABLE CHANNEL	TESTED CHANNEL	MODULATION TECHNOLOGY	MODULATION TYPE	DATA RATE (Mbps)
A	802.11a	149 to 161	149, 157, 161	OFDM	BPSK	6.0
	802.11n (20MHz)	149 to 161	149, 157, 161	OFDM	BPSK	MCS0
	802.11n (40MHz)	151 to 159	151, 159	OFDM	BPSK	MCS0

ANTENNA PORT CONDUCTED MEASUREMENT:

- Pre-Scan has been conducted to determine the worst-case mode from all possible combinations between available modulations, data rates and antenna ports (if EUT with antenna diversity architecture).
- Following channel(s) was (were) selected for the final test as listed below.

EUT CONFIGURE MODE	MODE	AVAILABLE CHANNEL	TESTED CHANNEL	MODULATION TECHNOLOGY	MODULATION TYPE	DATA RATE (Mbps)
A	802.11a	149 to 161	149, 157, 161	OFDM	BPSK	6.0
	802.11n (20MHz)	149 to 161	149, 157, 161	OFDM	BPSK	MCS0
	802.11n (40MHz)	151 to 159	151, 159	OFDM	BPSK	MCS0

Test CONDITION:

APPLICABLE TO	ENVIRONMENTAL CONDITIONS	INPUT POWER	TESTED BY
RE≥1G	25deg. C, 65%RH	120Vac, 60Hz	Johnson Liao
RE<1G	25deg. C, 65%RH	120Vac, 60Hz	Johnson Liao
PLC	25deg. C, 65%RH	120Vac, 60Hz	Peter Weng
APCM	25deg. C, 65%RH	120Vac, 60Hz	Howard Kao

3.3 DESCRIPTION OF SUPPORT UNITS

The EUT has been tested as an independent unit together with other necessary accessories or support units.

3.3.1 CONFIGURATION OF SYSTEM UNDER TEST

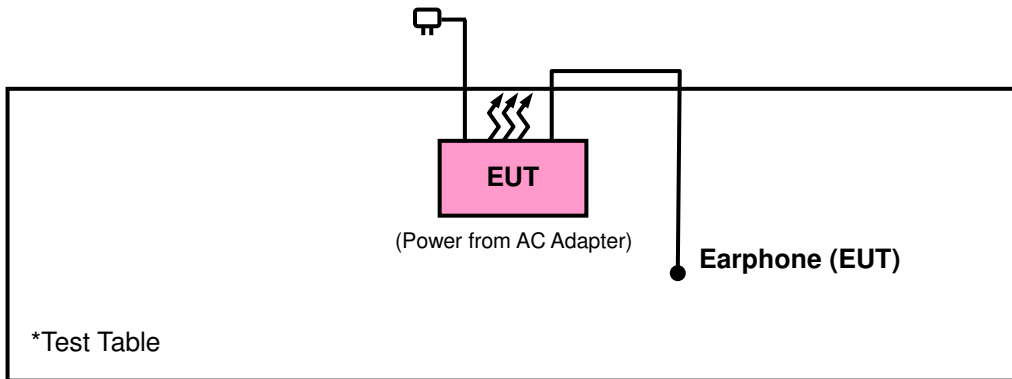



A D T

3.4 DUTY CYCLE TEST SIGNAL

WLAN 2.4GHz

If duty cycle is < 98%

802.11b: Duty cycle = 11.961/12.240 = 0.977, Duty factor = $10 * \log(1/0.977) = 0.10$

802.11g: Duty cycle = 1.352/1.569 = 0.862, Duty factor = $10 * \log(1/0.862) = 0.64$

802.11n (20MHz): Duty cycle = 1.268/1.492 = 0.850, Duty factor = $10 * \log(1/0.850) = 0.71$





A D T

5725MHz ~ 5805MHz

Duty cycle of test signal is > 98 %, duty factor is not required.

802.11a: Duty cycle = 1.354/1.370 = 0.988

802.11n (20MHz): Duty cycle = 1.274/1.298 = 0.982

If duty cycle is < 98%

802.11n (40MHz): Duty cycle = 595.51/643.59 = 0.925, Duty factor = $10 * \log(1/0.925) = 0.34$

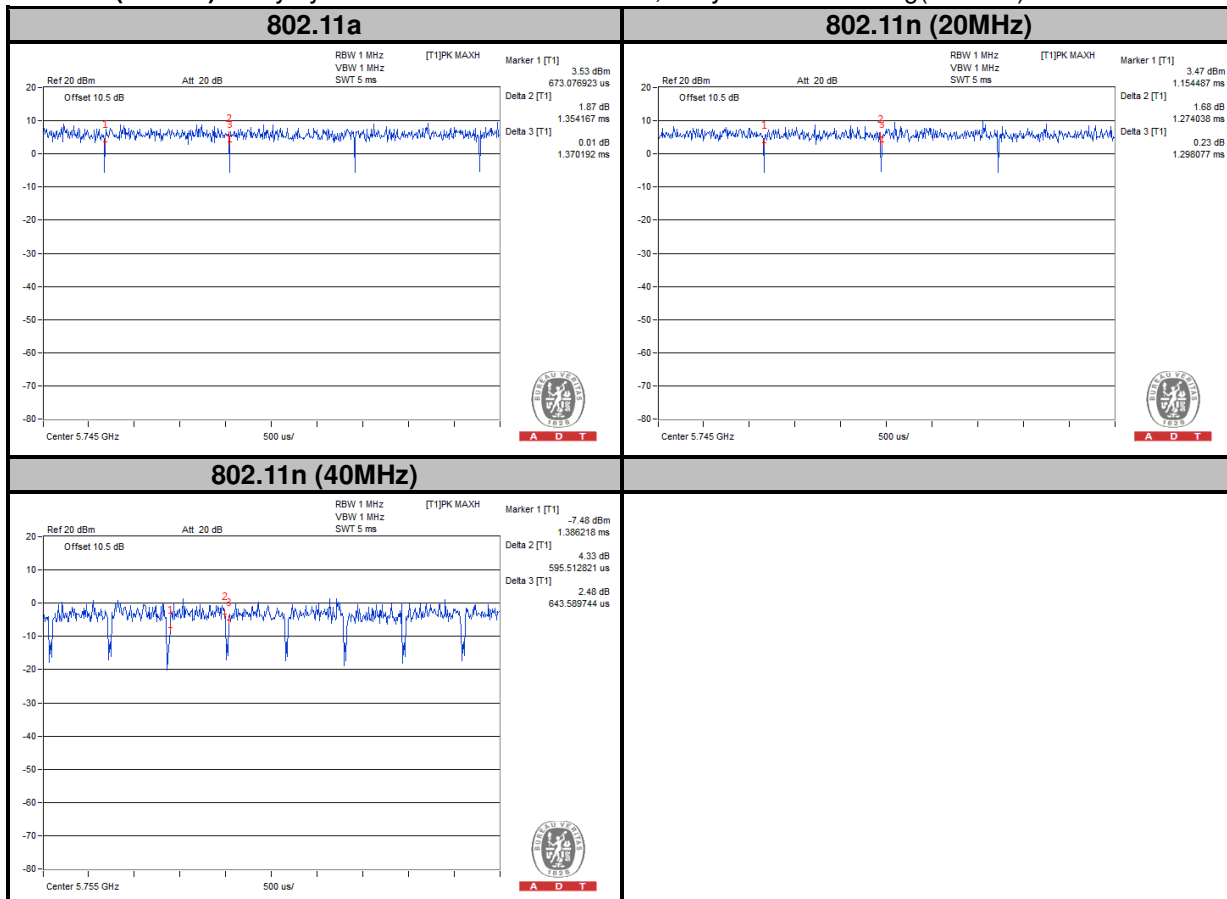



3.5 GENERAL DESCRIPTION OF APPLIED STANDARDS

The EUT is a RF Product. According to the specifications of the manufacturer, it must comply with the requirements of the following standards:

FCC Part 15, Subpart C (15.247)

ANSI C63.10-2009

558074 D01 DTS Meas Guidance v03r01

All test items have been performed and recorded as per the above standards.

NOTE: The EUT is also considered as a kind of computer peripheral, because the connection to computer is necessary for typical use. It has been verified to comply with the requirements of FCC Part 15, Subpart B, Class B (DoC). The test report has been issued separately.

4. TEST TYPES AND RESULTS (FOR 2.4GHz BAND)

4.1 RADIATED EMISSION AND BANDEDGE MEASUREMENT

4.1.1 LIMITS OF RADIATED EMISSION AND BANDEDGE MEASUREMENT

Radiated emissions which fall in the restricted bands must comply with the radiated emission limits specified as below table. Other emissions shall be at least 20dB below the highest level of the desired power:

FREQUENCIES (MHz)	FIELD STRENGTH (microvolts/meter)	MEASUREMENT DISTANCE (meters)
0.009 ~ 0.490	2400/F(kHz)	300
0.490 ~ 1.705	24000/F(kHz)	30
1.705 ~ 30.0	30	30
30 ~ 88	100	3
88 ~ 216	150	3
216 ~ 960	200	3
Above 960	500	3

NOTE:

1. The lower limit shall apply at the transition frequencies.
2. Emission level (dBuV/m) = 20 log Emission level (uV/m).
3. For frequencies above 1000MHz, the field strength limits are based on average detector, however, the peak field strength of any emission shall not exceed the maximum permitted average limits, specified above by more than 20dB under any condition of modulation.



4.1.2 TEST INSTRUMENTS

DESCRIPTION & MANUFACTURER	MODEL NO.	SERIAL NO.	DATE OF CALIBRATION	DUE DATE OF CALIBRATION
Test Receiver AGILENT	N9038A	MY51210203	Jan. 17, 2014	Jan. 16, 2015
Spectrum Analyzer ROHDE & SCHWARZ	FSU43	101261	Dec. 21, 2013	Dec. 20, 2014
BILOG Antenna SCHWARZBECK	VULB9168	9168-472	Feb. 27, 2014	Feb. 26, 2015
HORN Antenna SCHWARZBECK	BBHA 9120 D	9120D-969	Feb. 19, 2014	Feb. 18, 2015
HORN Antenna SCHWARZBECK	BBHA 9170	9170-480	Dec. 18, 2013	Dec. 17, 2014
Loop Antenna	HFH2-Z2	100070	Mar. 06, 2014	Mar. 05, 2016
Preamplifier EMCI	EMC 012645	980115	Dec. 26, 2013	Dec. 25, 2014
Preamplifier EMCI	EMC 184045	980116	Jan. 13, 2014	Jan. 12, 2015
Preamplifier EMCI	EMC 330H	980112	Dec. 27, 2013	Dec. 26, 2014
RF signal cable HUBER+SUHNNER	SUCOFLEX 104	309219/4 2950114	Oct. 18, 2013	Oct. 17, 2014
RF signal cable HUBER+SUHNNER	SUCOFLEX 104	250130/4	Oct. 18, 2013	Oct. 17, 2014
RF signal cable Worken	RG-213	NA	Nov. 07, 2013	Nov. 06, 2014
Software BV ADT	E3 6.120103	NA	NA	NA
Antenna Tower MF	MFA-440H	NA	NA	NA
Turn Table MF	MFT-201SS	NA	NA	NA
Antenna Tower & Turn Table Controller MF	MF-7802	NA	NA	NA
Power Meter	ML2495A	1232002	Aug. 23, 2013	Aug. 22, 2014
Power Sensor	MA2411B	1207325	Aug. 23, 2013	Aug. 22, 2014

- NOTE:**
1. The calibration interval of the above test instruments is 12 months and the calibrations are traceable to NML/ROC and NIST/USA.
 2. The calibration interval of the loop antenna is 24 months and the calibrations are traceable to NML/ROC and NIST/USA.
 3. The test was performed in HwaYa Chamber 10.
 4. The horn antenna and HP preamplifier (model: 8449B) are used only for the measurement of emission frequency above 1GHz if tested.
 5. The FCC Site Registration No. is 690701.
 6. The IC Site Registration No. is IC 7450F-10.

4.1.3 TEST PROCEDURES

- a. The EUT was placed on the top of a rotating table 0.8 meters above the ground at a 3 meters semi-anechoic chamber. The table was rotated 360 degrees to determine the position of the highest radiation.
- b. The EUT was set 3 meters away from the interference-receiving antenna, which was mounted on the top of a variable-height antenna tower.
- c. Height of receiving antenna is varied from one meter to four meters above the ground to determine the maximum value of the field strength. Both horizontal and vertical polarizations of the antenna are set to make the measurement.
- d. For each suspected emission, the EUT was arranged to its worst case and then the antenna was tuned to heights from 1 meter to 4 meters and the rotatable table was turned from 0 degrees to 360 degrees to find the maximum reading.
- e. The test-receiver system was set to Peak Detect Function and Specified Bandwidth with Maximum Hold Mode.
- f. If the emission level of the EUT in peak mode was lower than the limit specified, then testing could be stopped and the peak values of the EUT would be reported. Otherwise the emissions would be re-tested one by one using peak, quasi-peak or average method as specified and then reported in a data sheet.

NOTE:

1. The resolution bandwidth and video bandwidth of test receiver/spectrum analyzer is 120kHz for Quasi-peak detection at frequency below 1GHz.
2. The resolution bandwidth of test receiver/spectrum analyzer is 1MHz and video bandwidth is 3MHz for Peak detection at frequency above 1GHz.
3. The resolution bandwidth of test receiver/spectrum analyzer is 1MHz and the video bandwidth is 1kHz (Duty cycle < 98%) or 10Hz (Duty cycle > 98%) for Average detection (AV) at frequency above 1GHz.
4. All modes of operation were investigated and the worst-case emissions are reported.

4.1.4 DEVIATION FROM TEST STANDARD

No deviation.

4.1.5 TEST SETUP

Frequency Range 30MHz ~ 1GHz

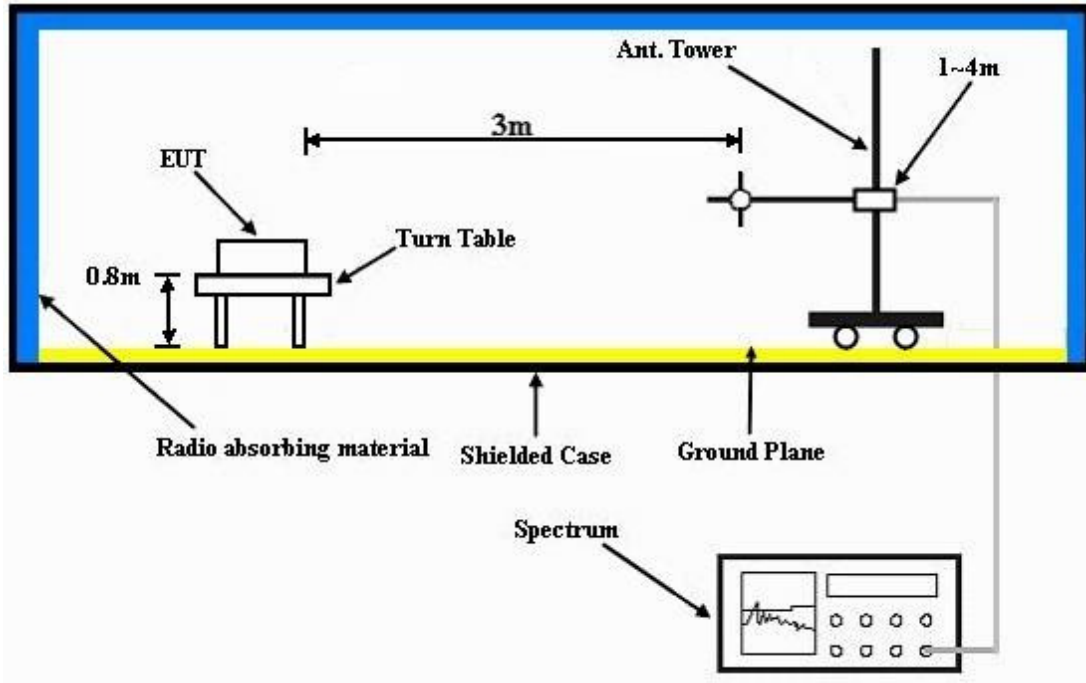

Frequency Range above 1GHz

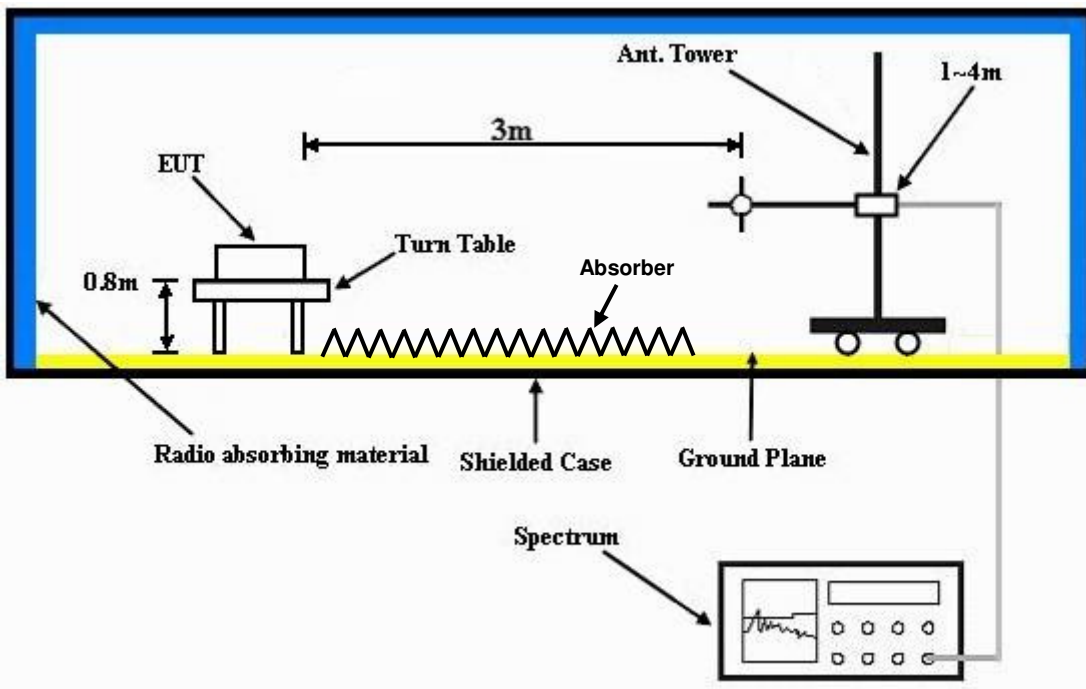

For the actual test configuration, please refer to the attached file (Test Setup Photo).



A D T

4.1.6 EUT OPERATING CONDITIONS

- a. Placed the EUT on a testing table.
- b. Use the software to control the EUT under transmission condition continuously at specific channel frequency.



A D T

4.1.7 TEST RESULTS

ABOVE 1GHz WORST-CASE DATA

MODE A

802.11b

EUT TEST CONDITION		MEASUREMENT DETAIL	
CHANNEL	Channel 1	FREQUENCY RANGE	1GHz ~ 25GHz
INPUT POWER	120Vac, 60 Hz	DETECTOR FUNCTION	Peak (PK) Average (AV)
ENVIRONMENTAL CONDITIONS	25deg. C, 65%RH	TESTED BY	Johnson Liao

ANTENNA POLARITY & TEST DISTANCE: HORIZONTAL AT 3 M										
FREQ. (MHz)	EMISSION LEVEL (dBuV/m)	READ LEVEL (dBuV)	LIMIT (dBuV/m)	MARGIN (dB)	ANTENNA FACTOR (dB/m)	CABLE LOSS (dB)	PREAMP FACTOR (dB)	ANTENNA HEIGHT (cm)	TABLE ANGLE (Degree)	REMARK
2390	43.18	50.25	54	-10.82	26.91	3.54	37.52	120	192	Average
2390	55.38	62.45	74	-18.62	26.91	3.54	37.52	120	192	Peak
2412	105.2	112.22			26.96	3.54	37.52	120	192	Average
2412	109.47	116.49			26.96	3.54	37.52	120	192	Peak
2484	35.06	41.63	54	-18.94	27.15	3.6	37.32	120	192	Average
2484	52.06	58.63	74	-21.94	27.15	3.6	37.32	120	192	Peak
ANTENNA POLARITY & TEST DISTANCE: VERTICAL AT 3 M										
FREQ. (MHz)	EMISSION LEVEL (dBuV/m)	READ LEVEL (dBuV)	LIMIT (dBuV/m)	MARGIN (dB)	ANTENNA FACTOR (dB/m)	CABLE LOSS (dB)	PREAMP FACTOR (dB)	ANTENNA HEIGHT (cm)	TABLE ANGLE (Degree)	REMARK
2390	40.99	48.06	54	-13.01	26.91	3.54	37.52	100	89	Average
2390	52.99	60.06	74	-21.01	26.91	3.54	37.52	100	89	Peak
2412	103.13	110.15			26.96	3.54	37.52	100	89	Average
2412	107.68	114.7			26.96	3.54	37.52	100	89	Peak
2490	35.28	41.78	54	-18.72	27.2	3.62	37.32	100	89	Average
2490	53.57	60.07	74	-20.43	27.2	3.62	37.32	100	89	Peak

REMARKS:

- Emission Level = Read Level + Antenna Factor + Cable Loss - Preamp Factor
Margin value = Emission level – Limit value
- 2412MHz: Fundamental frequency.



A D T

EUT TEST CONDITION		MEASUREMENT DETAIL	
CHANNEL	Channel 6	FREQUENCY RANGE	1GHz ~ 25GHz
INPUT POWER	120Vac, 60 Hz	DETECTOR FUNCTION	Peak (PK) Average (AV)
ENVIRONMENTAL CONDITIONS	25deg. C, 65%RH	TESTED BY	Johnson Liao

ANTENNA POLARITY & TEST DISTANCE: HORIZONTAL AT 3 M

FREQ. (MHz)	EMISSION LEVEL (dBuV/m)	READ LEVEL (dBuV)	LIMIT (dBuV/m)	MARGIN (dB)	ANTENNA FACTOR (dB/m)	CABLE LOSS (dB)	PREAMP FACTOR (dB)	ANTENNA HEIGHT (cm)	TABLE ANGLE (Degree)	REMARK
2390	34.77	41.84	54	-19.23	26.91	3.54	37.52	118	0	Average
2390	52.56	59.63	74	-21.44	26.91	3.54	37.52	118	0	Peak
2437	105.5	112.34			27.06	3.56	37.46	118	0	Average
2437	109.9	116.74			27.06	3.56	37.46	118	0	Peak
2498	36.62	43.05	54	-17.38	27.2	3.62	37.25	118	0	Average
2498	52.32	58.75	74	-21.68	27.2	3.62	37.25	118	0	Peak

ANTENNA POLARITY & TEST DISTANCE: VERTICAL AT 3 M

FREQ. (MHz)	EMISSION LEVEL (dBuV/m)	READ LEVEL (dBuV)	LIMIT (dBuV/m)	MARGIN (dB)	ANTENNA FACTOR (dB/m)	CABLE LOSS (dB)	PREAMP FACTOR (dB)	ANTENNA HEIGHT (cm)	TABLE ANGLE (Degree)	REMARK
2372	34.36	41.48	54	-19.64	26.86	3.52	37.5	100	88	Average
2372	52.81	59.93	74	-21.19	26.86	3.52	37.5	100	88	Peak
2437	103.44	110.28			27.06	3.56	37.46	100	88	Average
2437	107.43	114.27			27.06	3.56	37.46	100	88	Peak
2484	35.69	42.26	54	-18.31	27.15	3.6	37.32	100	88	Average
2484	52.35	58.92	74	-21.65	27.15	3.6	37.32	100	88	Peak

REMARKS:

- Emission Level = Read Level + Antenna Factor + Cable Loss - Preamp Factor
Margin value = Emission level – Limit value
- 2437MHz: Fundamental frequency.



A D T

EUT TEST CONDITION		MEASUREMENT DETAIL	
CHANNEL	Channel 11	FREQUENCY RANGE	1GHz ~ 25GHz
INPUT POWER	120Vac, 60 Hz	DETECTOR FUNCTION	Peak (PK) Average (AV)
ENVIRONMENTAL CONDITIONS	25deg. C, 65%RH	TESTED BY	Johnson Liao

ANTENNA POLARITY & TEST DISTANCE: HORIZONTAL AT 3 M

FREQ. (MHz)	EMISSION LEVEL (dBuV/m)	READ LEVEL (dBuV)	LIMIT (dBuV/m)	MARGIN (dB)	ANTENNA FACTOR (dB/m)	CABLE LOSS (dB)	PREAMP FACTOR (dB)	ANTENNA HEIGHT (cm)	TABLE ANGLE (Degree)	REMARK
2338	34.01	41.21	54	-19.99	26.77	3.5	37.47	118	0	Average
2338	52.08	59.28	74	-21.92	26.77	3.5	37.47	118	0	Peak
2462	105.04	111.75			27.1	3.58	37.39	118	0	Average
2462	109.07	115.78			27.1	3.58	37.39	118	0	Peak
2484	45.01	51.58	54	-8.99	27.15	3.6	37.32	118	0	Average
2484	55.86	62.43	74	-18.14	27.15	3.6	37.32	118	0	Peak

ANTENNA POLARITY & TEST DISTANCE: VERTICAL AT 3 M

FREQ. (MHz)	EMISSION LEVEL (dBuV/m)	READ LEVEL (dBuV)	LIMIT (dBuV/m)	MARGIN (dB)	ANTENNA FACTOR (dB/m)	CABLE LOSS (dB)	PREAMP FACTOR (dB)	ANTENNA HEIGHT (cm)	TABLE ANGLE (Degree)	REMARK
2390	34.44	41.51	54	-19.56	26.91	3.54	37.52	100	89	Average
2390	52.66	59.73	74	-21.34	26.91	3.54	37.52	100	89	Peak
2462	103.31	110.02			27.1	3.58	37.39	100	89	Average
2462	107.65	114.36			27.1	3.58	37.39	100	89	Peak
2484	44.64	51.21	54	-9.36	27.15	3.6	37.32	100	89	Average
2484	54.71	61.28	74	-19.29	27.15	3.6	37.32	100	89	Peak

REMARKS:

- Emission Level = Read Level + Antenna Factor + Cable Loss - Preamp Factor
Margin value = Emission level – Limit value
- 2462MHz: Fundamental frequency.



A D T

802.11g

EUT TEST CONDITION		MEASUREMENT DETAIL	
CHANNEL	Channel 1	FREQUENCY RANGE	1GHz ~ 25GHz
INPUT POWER	120Vac, 60 Hz	DETECTOR FUNCTION	Peak (PK) Average (AV)
ENVIRONMENTAL CONDITIONS	25deg. C, 65%RH	TESTED BY	Johnson Liao

ANTENNA POLARITY & TEST DISTANCE: HORIZONTAL AT 3 M

FREQ. (MHz)	EMISSION LEVEL (dBuV/m)	READ LEVEL (dBuV)	LIMIT (dBuV/m)	MARGIN (dB)	ANTENNA FACTOR (dB/m)	CABLE LOSS (dB)	PREAMP FACTOR (dB)	ANTENNA HEIGHT (cm)	TABLE ANGLE (Degree)	REMARK
2390	49.45	56.52	54	-4.55	26.91	3.54	37.52	100	2	Average
2390	67.18	74.25	74	-6.82	26.91	3.54	37.52	100	2	Peak
2412	97.8	104.82			26.96	3.54	37.52	100	2	Average
2412	107.23	114.25			26.96	3.54	37.52	100	2	Peak
2484	35.13	41.7	54	-18.87	27.15	3.6	37.32	100	2	Average
2484	49.53	56.1	74	-24.47	27.15	3.6	37.32	100	2	Peak

ANTENNA POLARITY & TEST DISTANCE: VERTICAL AT 3 M

FREQ. (MHz)	EMISSION LEVEL (dBuV/m)	READ LEVEL (dBuV)	LIMIT (dBuV/m)	MARGIN (dB)	ANTENNA FACTOR (dB/m)	CABLE LOSS (dB)	PREAMP FACTOR (dB)	ANTENNA HEIGHT (cm)	TABLE ANGLE (Degree)	REMARK
2390	47.98	55.05	54	-6.02	26.91	3.54	37.52	100	88	Average
2390	65.42	72.49	74	-8.58	26.91	3.54	37.52	100	88	Peak
2412	96.9	103.92			26.96	3.54	37.52	100	88	Average
2412	106.84	113.86			26.96	3.54	37.52	100	88	Peak
2484	35.4	41.97	54	-18.6	27.15	3.6	37.32	100	88	Average
2484	49.22	55.79	74	-24.78	27.15	3.6	37.32	100	88	Peak

REMARKS:

- Emission Level = Read Level + Antenna Factor + Cable Loss - Preamp Factor
Margin value = Emission level – Limit value
- 2412MHz: Fundamental frequency.



A D T

EUT TEST CONDITION		MEASUREMENT DETAIL	
CHANNEL	Channel 6	FREQUENCY RANGE	1GHz ~ 25GHz
INPUT POWER	120Vac, 60 Hz	DETECTOR FUNCTION	Peak (PK) Average (AV)
ENVIRONMENTAL CONDITIONS	25deg. C, 65%RH	TESTED BY	Johnson Liao

ANTENNA POLARITY & TEST DISTANCE: HORIZONTAL AT 3 M										
FREQ. (MHz)	EMISSION LEVEL (dBuV/m)	READ LEVEL (dBuV)	LIMIT (dBuV/m)	MARGIN (dB)	ANTENNA FACTOR (dB/m)	CABLE LOSS (dB)	PREAMP FACTOR (dB)	ANTENNA HEIGHT (cm)	TABLE ANGLE (Degree)	REMARK
2390	36.7	43.77	54	-17.3	26.91	3.54	37.52	100	3	Average
2390	50.46	57.53	74	-23.54	26.91	3.54	37.52	100	3	Peak
2437	99.51	106.35			27.06	3.56	37.46	100	3	Average
2437	109.73	116.57			27.06	3.56	37.46	100	3	Peak
2484	39.32	45.89	54	-14.68	27.15	3.6	37.32	100	3	Average
2484	51.16	57.73	74	-22.84	27.15	3.6	37.32	100	3	Peak

ANTENNA POLARITY & TEST DISTANCE: VERTICAL AT 3 M										
FREQ. (MHz)	EMISSION LEVEL (dBuV/m)	READ LEVEL (dBuV)	LIMIT (dBuV/m)	MARGIN (dB)	ANTENNA FACTOR (dB/m)	CABLE LOSS (dB)	PREAMP FACTOR (dB)	ANTENNA HEIGHT (cm)	TABLE ANGLE (Degree)	REMARK
2390	35.73	42.8	54	-18.27	26.91	3.54	37.52	100	88	Average
2390	50.34	57.41	74	-23.66	26.91	3.54	37.52	100	88	Peak
2437	98.59	105.43			27.06	3.56	37.46	100	88	Average
2437	108.27	115.11			27.06	3.56	37.46	100	88	Peak
2484	40.04	46.61	54	-13.96	27.15	3.6	37.32	100	88	Average
2484	52.58	59.15	74	-21.42	27.15	3.6	37.32	100	88	Peak

REMARKS:

- Emission Level = Read Level + Antenna Factor + Cable Loss - Preamp Factor
Margin value = Emission level – Limit value
- 2437MHz: Fundamental frequency.



A D T

EUT TEST CONDITION		MEASUREMENT DETAIL	
CHANNEL	Channel 11	FREQUENCY RANGE	1GHz ~ 25GHz
INPUT POWER	120Vac, 60 Hz	DETECTOR FUNCTION	Peak (PK) Average (AV)
ENVIRONMENTAL CONDITIONS	25deg. C, 65%RH	TESTED BY	Johnson Liao

ANTENNA POLARITY & TEST DISTANCE: HORIZONTAL AT 3 M

FREQ. (MHz)	EMISSION LEVEL (dBuV/m)	READ LEVEL (dBuV)	LIMIT (dBuV/m)	MARGIN (dB)	ANTENNA FACTOR (dB/m)	CABLE LOSS (dB)	PREAMP FACTOR (dB)	ANTENNA HEIGHT (cm)	TABLE ANGLE (Degree)	REMARK
2388	32.07	39.12	54	-21.93	26.91	3.54	37.5	100	3	Average
2388	49.98	57.03	74	-24.02	26.91	3.54	37.5	100	3	Peak
2462	98.27	104.98			27.1	3.58	37.39	100	3	Average
2462	108.12	114.83			27.1	3.58	37.39	100	3	Peak
2484	50.34	56.91	54	-3.66	27.15	3.6	37.32	100	3	Average
2484	67.77	74.34	74	-6.23	27.15	3.6	37.32	100	3	Peak

ANTENNA POLARITY & TEST DISTANCE: VERTICAL AT 3 M

FREQ. (MHz)	EMISSION LEVEL (dBuV/m)	READ LEVEL (dBuV)	LIMIT (dBuV/m)	MARGIN (dB)	ANTENNA FACTOR (dB/m)	CABLE LOSS (dB)	PREAMP FACTOR (dB)	ANTENNA HEIGHT (cm)	TABLE ANGLE (Degree)	REMARK
2366	34.31	41.48	54	-19.69	26.81	3.52	37.5	100	87	Average
2366	49.79	56.96	74	-24.21	26.81	3.52	37.5	100	87	Peak
2462	97.58	104.29			27.1	3.58	37.39	100	87	Average
2462	107.25	113.96			27.1	3.58	37.39	100	87	Peak
2484	50.97	57.54	54	-3.03	27.15	3.6	37.32	100	87	Average
2484	69.43	76	74	-4.57	27.15	3.6	37.32	100	87	Peak

REMARKS:

- Emission Level = Read Level + Antenna Factor + Cable Loss - Preamp Factor
Margin value = Emission level – Limit value
- 2462MHz: Fundamental frequency.



A D T

802.11n (20MHz)

EUT TEST CONDITION		MEASUREMENT DETAIL	
CHANNEL	Channel 1	FREQUENCY RANGE	1GHz ~ 25GHz
INPUT POWER	120Vac, 60 Hz	DETECTOR FUNCTION	Peak (PK) Average (AV)
ENVIRONMENTAL CONDITIONS	25deg. C, 65%RH	TESTED BY	Johnson Liao

ANTENNA POLARITY & TEST DISTANCE: HORIZONTAL AT 3 M										
FREQ. (MHz)	EMISSION LEVEL (dBuV/m)	READ LEVEL (dBuV)	LIMIT (dBuV/m)	MARGIN (dB)	ANTENNA FACTOR (dB/m)	CABLE LOSS (dB)	PREAMP FACTOR (dB)	ANTENNA HEIGHT (cm)	TABLE ANGLE (Degree)	REMARK
2390	50.11	57.18	54	-3.89	26.91	3.54	37.52	100	90	Average
2390	70.62	77.69	74	-3.38	26.91	3.54	37.52	100	90	Peak
2412	98.32	105.34			26.96	3.54	37.52	100	90	Average
2412	108	115.02			26.96	3.54	37.52	100	90	Peak
2484	35.72	42.29	54	-18.28	27.15	3.6	37.32	100	90	Average
2484	50.09	56.66	74	-23.91	27.15	3.6	37.32	100	90	Peak

ANTENNA POLARITY & TEST DISTANCE: VERTICAL AT 3 M										
FREQ. (MHz)	EMISSION LEVEL (dBuV/m)	READ LEVEL (dBuV)	LIMIT (dBuV/m)	MARGIN (dB)	ANTENNA FACTOR (dB/m)	CABLE LOSS (dB)	PREAMP FACTOR (dB)	ANTENNA HEIGHT (cm)	TABLE ANGLE (Degree)	REMARK
2390	49.91	56.98	54	-4.09	26.91	3.54	37.52	124	16	Average
2390	70.89	77.96	74	-3.11	26.91	3.54	37.52	124	16	Peak
2412	96.91	103.93			26.96	3.54	37.52	124	16	Average
2412	106.77	113.79			26.96	3.54	37.52	124	16	Peak
2484	34.27	40.84	54	-19.73	27.15	3.6	37.32	124	16	Average
2484	49.08	55.65	74	-24.92	27.15	3.6	37.32	124	16	Peak

REMARKS:

- Emission Level = Read Level + Antenna Factor + Cable Loss - Preamp Factor
Margin value = Emission level – Limit value
- 2412MHz: Fundamental frequency.



A D T

EUT TEST CONDITION		MEASUREMENT DETAIL	
CHANNEL	Channel 6	FREQUENCY RANGE	1GHz ~ 25GHz
INPUT POWER	120Vac, 60 Hz	DETECTOR FUNCTION	Peak (PK) Average (AV)
ENVIRONMENTAL CONDITIONS	25deg. C, 65%RH	TESTED BY	Johnson Liao

ANTENNA POLARITY & TEST DISTANCE: HORIZONTAL AT 3 M

FREQ. (MHz)	EMISSION LEVEL (dBuV/m)	READ LEVEL (dBuV)	LIMIT (dBuV/m)	MARGIN (dB)	ANTENNA FACTOR (dB/m)	CABLE LOSS (dB)	PREAMP FACTOR (dB)	ANTENNA HEIGHT (cm)	TABLE ANGLE (Degree)	REMARK
2390	37.14	44.21	54	-16.86	26.91	3.54	37.52	120	15	Average
2390	52.17	59.24	74	-21.83	26.91	3.54	37.52	120	15	Peak
2437	99.07	105.91			27.06	3.56	37.46	120	15	Average
2437	108.84	115.68			27.06	3.56	37.46	120	15	Peak
2488	40.73	47.23	54	-13.27	27.2	3.62	37.32	120	15	Average
2488	51.49	57.99	74	-22.51	27.2	3.62	37.32	120	15	Peak

ANTENNA POLARITY & TEST DISTANCE: VERTICAL AT 3 M

FREQ. (MHz)	EMISSION LEVEL (dBuV/m)	READ LEVEL (dBuV)	LIMIT (dBuV/m)	MARGIN (dB)	ANTENNA FACTOR (dB/m)	CABLE LOSS (dB)	PREAMP FACTOR (dB)	ANTENNA HEIGHT (cm)	TABLE ANGLE (Degree)	REMARK
2366	36.14	43.31	54	-17.86	26.81	3.52	37.5	100	85	Average
2366	50.83	58	74	-23.17	26.81	3.52	37.5	100	85	Peak
2437	97.63	104.47			27.06	3.56	37.46	100	85	Average
2437	106.08	112.92			27.06	3.56	37.46	100	85	Peak
2484	41.37	47.94	54	-12.63	27.15	3.6	37.32	100	85	Average
2484	52.16	58.73	74	-21.84	27.15	3.6	37.32	100	85	Peak

REMARKS:

- Emission Level = Read Level + Antenna Factor + Cable Loss - Preamp Factor
Margin value = Emission level – Limit value
- 2437MHz: Fundamental frequency.



A D T

EUT TEST CONDITION		MEASUREMENT DETAIL	
CHANNEL	Channel 11	FREQUENCY RANGE	1GHz ~ 25GHz
INPUT POWER	120Vac, 60 Hz	DETECTOR FUNCTION	Peak (PK) Average (AV)
ENVIRONMENTAL CONDITIONS	25deg. C, 65%RH	TESTED BY	Johnson Liao

ANTENNA POLARITY & TEST DISTANCE: HORIZONTAL AT 3 M

FREQ. (MHz)	EMISSION LEVEL (dBuV/m)	READ LEVEL (dBuV)	LIMIT (dBuV/m)	MARGIN (dB)	ANTENNA FACTOR (dB/m)	CABLE LOSS (dB)	PREAMP FACTOR (dB)	ANTENNA HEIGHT (cm)	TABLE ANGLE (Degree)	REMARK
2362	34.04	41.22	54	-19.96	26.81	3.5	37.49	120	9	Average
2362	49.93	57.11	74	-24.07	26.81	3.5	37.49	120	9	Peak
2462	97.37	104.08			27.1	3.58	37.39	120	9	Average
2462	106.88	113.59			27.1	3.58	37.39	120	9	Peak
2484	50.66	57.23	54	-3.34	27.15	3.6	37.32	120	9	Average
2484	66.78	73.35	74	-7.22	27.15	3.6	37.32	120	9	Peak

ANTENNA POLARITY & TEST DISTANCE: VERTICAL AT 3 M

FREQ. (MHz)	EMISSION LEVEL (dBuV/m)	READ LEVEL (dBuV)	LIMIT (dBuV/m)	MARGIN (dB)	ANTENNA FACTOR (dB/m)	CABLE LOSS (dB)	PREAMP FACTOR (dB)	ANTENNA HEIGHT (cm)	TABLE ANGLE (Degree)	REMARK
2344	33.95	41.17	54	-20.05	26.77	3.5	37.49	100	87	Average
2344	50.41	57.63	74	-23.59	26.77	3.5	37.49	100	87	Peak
2462	95.57	102.28			27.1	3.58	37.39	100	87	Average
2462	104.59	111.3			27.1	3.58	37.39	100	87	Peak
2484	50.92	57.49	54	-3.08	27.15	3.6	37.32	100	87	Average
2484	70.02	76.59	74	-3.98	27.15	3.6	37.32	100	87	Peak

REMARKS:

- Emission Level = Read Level + Antenna Factor + Cable Loss - Preamp Factor
Margin value = Emission level – Limit value
- 2462MHz: Fundamental frequency.



A D T

MODE B

802.11g

EUT TEST CONDITION		MEASUREMENT DETAIL	
CHANNEL	Channel 11	FREQUENCY RANGE	1GHz ~ 25GHz
INPUT POWER	120Vac, 60 Hz	DETECTOR FUNCTION	Peak (PK) Average (AV)
ENVIRONMENTAL CONDITIONS	25deg. C, 65%RH	TESTED BY	Johnson Liao

ANTENNA POLARITY & TEST DISTANCE: HORIZONTAL AT 3 M

FREQ. (MHz)	EMISSION LEVEL (dBuV/m)	READ LEVEL (dBuV)	LIMIT (dBuV/m)	MARGIN (dB)	ANTENNA FACTOR (dB/m)	CABLE LOSS (dB)	PREAMP FACTOR (dB)	ANTENNA HEIGHT (cm)	TABLE ANGLE (Degree)	REMARK
2390	34.44	41.51	54	-19.56	26.91	3.54	37.52	118	190	Average
2390	55.99	63.06	74	-18.01	26.91	3.54	37.52	118	190	Peak
2462	98.21	104.92			27.1	3.58	37.39	118	190	Average
2462	107.73	114.44			27.1	3.58	37.39	118	190	Peak
2484	50.2	56.77	54	-3.8	27.15	3.6	37.32	118	190	Average
2484	69.95	76.52	74	-4.05	27.15	3.6	37.32	118	190	Peak

ANTENNA POLARITY & TEST DISTANCE: VERTICAL AT 3 M

FREQ. (MHz)	EMISSION LEVEL (dBuV/m)	READ LEVEL (dBuV)	LIMIT (dBuV/m)	MARGIN (dB)	ANTENNA FACTOR (dB/m)	CABLE LOSS (dB)	PREAMP FACTOR (dB)	ANTENNA HEIGHT (cm)	TABLE ANGLE (Degree)	REMARK
2390	34.41	41.48	54	-19.59	26.91	3.54	37.52	100	271	Average
2390	56.24	63.31	74	-17.76	26.91	3.54	37.52	100	271	Peak
2462	97.16	103.87			27.1	3.58	37.39	100	271	Average
2462	107.18	113.89			27.1	3.58	37.39	100	271	Peak
2484	48.87	55.44	54	-5.13	27.15	3.6	37.32	100	271	Average
2484	68.53	75.1	74	-5.47	27.15	3.6	37.32	100	271	Peak

REMARKS:

- Emission Level = Read Level + Antenna Factor + Cable Loss - Preamp Factor
Margin value = Emission level – Limit value
- 2462MHz: Fundamental frequency.



A D T

BELOW 1GHz WORST-CASE DATA:

802.11g

EUT TEST CONDITION		MEASUREMENT DETAIL	
CHANNEL	Channel 11	FREQUENCY RANGE	30MHz ~ 1GHz
INPUT POWER	120Vac, 60 Hz	DETECTOR FUNCTION	Peak (PK)
ENVIRONMENTAL CONDITIONS	25deg. C, 65%RH	TESTED BY	Johnson Liao

ANTENNA POLARITY & TEST DISTANCE: HORIZONTAL AT 3 M

FREQ. (MHz)	EMISSION LEVEL (dBuV/m)	READ LEVEL (dBuV)	LIMIT (dBuV/m)	MARGIN (dB)	ANTENNA FACTOR (dB/m)	CABLE LOSS (dB)	PREAMP FACTOR (dB)	ANTENNA HEIGHT (cm)	TABLE ANGLE (Degree)	REMARK
102.63	21.6	43.1	43.5	-21.9	9.34	1.08	31.92	100	93	Peak
166.89	24.81	43.1	43.5	-18.69	12.05	1.43	31.77	100	202	Peak
225.75	20.44	40.06	46	-25.56	10.46	1.72	31.8	100	104	Peak
554.1	21.65	32.13	46	-24.35	18.55	2.96	31.99	100	133	Peak
778.8	26.06	31.91	46	-19.94	21.93	3.64	31.42	100	290	Peak
957.3	28.26	32.24	46	-17.74	23.83	4.09	31.9	100	146	Peak

ANTENNA POLARITY & TEST DISTANCE: VERTICAL AT 3 M

FREQ. (MHz)	EMISSION LEVEL (dBuV/m)	READ LEVEL (dBuV)	LIMIT (dBuV/m)	MARGIN (dB)	ANTENNA FACTOR (dB/m)	CABLE LOSS (dB)	PREAMP FACTOR (dB)	ANTENNA HEIGHT (cm)	TABLE ANGLE (Degree)	REMARK
31.08	35.86	54.27	40	-4.14	12.14	0.57	31.12	100	156	Peak
62.67	27.1	46.16	40	-12.9	11.59	0.85	31.5	100	211	Peak
153.93	22.85	40.49	43.5	-20.65	12.72	1.36	31.72	100	240	Peak
388.2	18.71	33.3	46	-27.29	15.05	2.38	32.02	100	182	Peak
626.2	22.83	31.88	46	-23.17	19.93	3.17	32.15	100	299	Peak
939.1	27.67	31.83	46	-18.33	23.73	4.05	31.94	100	352	Peak

REMARKS: Emission Level = Read Level + Antenna Factor + Cable Loss - Preamp Factor

Margin value = Emission level – Limit value

4.2 CONDUCTED EMISSION MEASUREMENT

4.2.1 LIMITS OF CONDUCTED EMISSION MEASUREMENT

FREQUENCY OF EMISSION (MHz)	CONDUCTED LIMIT (dB μ V)	
	Quasi-peak	Average
0.15 ~ 0.5	66 to 56	56 to 46
0.5 ~ 5	56	46
5 ~ 30	60	50

- NOTE:**
1. The lower limit shall apply at the transition frequencies.
 2. The limit decreases in line with the logarithm of the frequency in the range of 0.15 to 0.50MHz.
 3. All emanations from a class A/B digital device or system, including any network of conductors and apparatus connected thereto, shall not exceed the level of field strengths specified above.

4.2.2 TEST INSTRUMENTS

DESCRIPTION & MANUFACTURER	MODEL NO.	SERIAL NO.	DATE OF CALIBRATION	DUE DATE OF CALIBRATION
Test Receiver ROHDE & SCHWARZ	ESCS30	100288	Nov. 17, 2013	Nov. 16, 2014
RF signal cable Woken	5D-FB	Cable-HYCO2-01	Dec. 27, 2013	Dec. 26, 2014
LISN ROHDE & SCHWARZ (EUT)	ESH2-Z5	100100	Dec. 23, 2013	Dec. 22, 2014
LISN ROHDE & SCHWARZ (Peripheral)	ESH3-Z5	100312	Jul. 08, 2013	Jul. 07, 2014
Software ADT	BV ADT_Cond_ V7.3.7.3	NA	NA	NA

- NOTE:**
1. The calibration interval of the above test instruments is 12 months and the calibrations are traceable to NML/ROC and NIST/USA.
 2. The test was performed in HwaYa Shielded Room 2.
 3. The VCCI Site Registration No. is C-2047.

4.2.3 TEST PROCEDURES

- a. The EUT was placed 0.4 meters from the conducting wall of the shielded room with EUT being connected to the power mains through a line impedance stabilization network (LISN). Other support units were connected to the power mains through another LISN. The two LISNs provide 50 ohm/ 50uH of coupling impedance for the measuring instrument.
- b. Both lines of the power mains connected to the EUT were checked for maximum conducted interference.
- c. The frequency range from 150kHz to 30MHz was searched. Emission levels under (Limit - 20dB) was not recorded.

NOTE: All modes of operation were investigated and the worst-case emissions are reported.

4.2.4 DEVIATION FROM TEST STANDARD

No deviation.

4.2.5 TEST SETUP

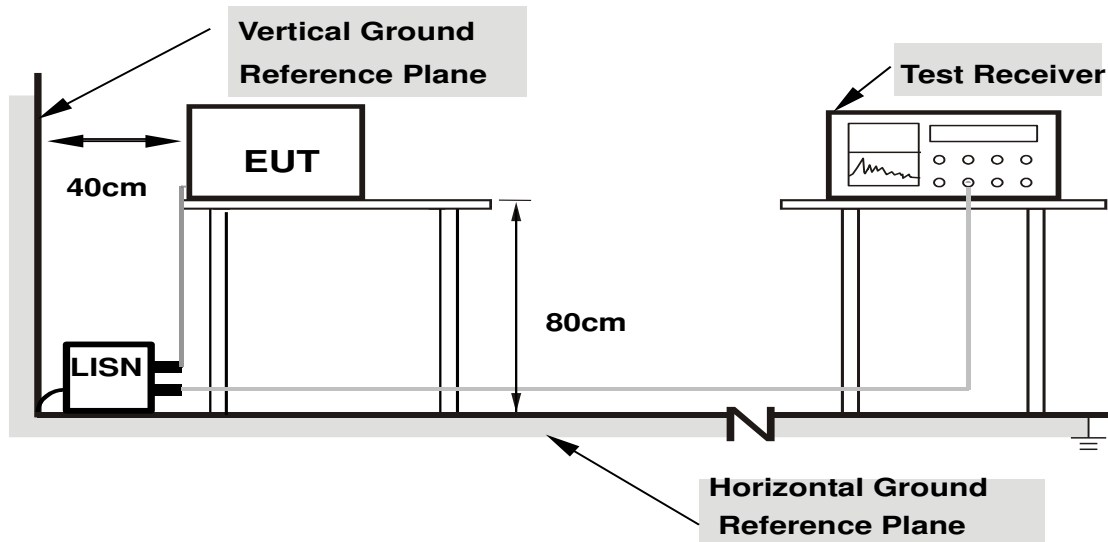

- Note:**
- 1.Support units were connected to second LISN.
 - 2.Both of LISNs (AMN) are 80 cm from EUT and at least 80 from other units and other metal planes

For the actual test configuration, please refer to the attached file (Test Setup Photo).

4.2.6 EUT OPERATING CONDITIONS

Same as section 4.1.6.

4.2.7 TEST RESULTS

CONDUCTED WORST-CASE DATA :

MODE A

PHASE	Line 1	6dB BANDWIDTH	9kHz
--------------	--------	----------------------	------

No	Freq.	Corr. Factor	Reading Value		Emission Level		Limit		Margin	
	[MHz]		[dB (uV)]		[dB (uV)]		[dB (uV)]		(dB)	
			Q.P.	AV.	Q.P.	AV.	Q.P.	AV.	Q.P.	AV.
1	0.16953	0.27	37.15	9.83	37.42	10.10	64.98	54.98	-27.56	-44.88
2	0.50547	0.31	43.21	32.33	43.52	32.64	56.00	46.00	-12.48	-13.36
3	1.34375	0.35	39.78	28.01	40.13	28.36	56.00	46.00	-15.87	-17.64
4	2.85547	0.39	43.25	32.92	43.64	33.31	56.00	46.00	-12.36	-12.69
5	13.55859	0.52	53.12	46.27	53.64	46.79	60.00	50.00	-6.36	-3.21
6	22.11719	0.57	35.23	23.33	35.80	23.90	60.00	50.00	-24.20	-26.10

REMARKS:

1. Q.P. and AV. are abbreviations of quasi-peak and average individually.
2. The emission levels of other frequencies were very low against the limit.
3. Margin value = Emission level - Limit value
4. Correction factor = Insertion loss + Cable loss
5. Emission Level = Correction Factor + Reading Value

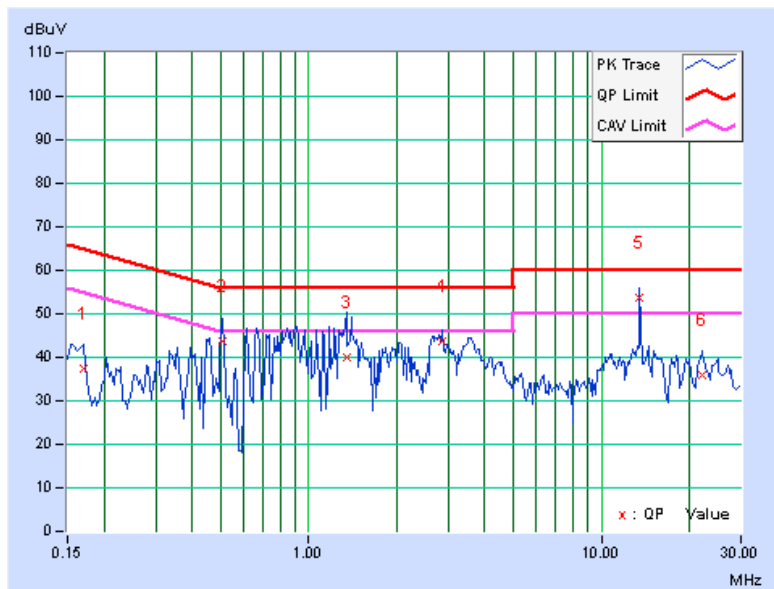

PHASE	Line 2	6dB BANDWIDTH	9kHz
-------	--------	---------------	------

No	Freq. [MHz]	Corr. Factor (dB)	Reading Value [dB (uV)]		Emission Level [dB (uV)]		Limit [dB (uV)]		Margin (dB)	
			Q.P.	AV.	Q.P.	AV.	Q.P.	AV.	Q.P.	AV.
			1	0.16172	0.27	35.12	12.39	35.39	12.66	65.38
2	0.30625	0.29	30.48	16.19	30.77	16.48	60.07	50.07	-29.30	-33.59
3	1.46094	0.35	33.22	23.01	33.57	23.36	56.00	46.00	-22.43	-22.64
4	3.33984	0.42	25.31	10.97	25.73	11.39	56.00	46.00	-30.27	-34.61
5	13.56250	0.55	43.90	41.93	44.45	42.48	60.00	50.00	-15.55	-7.52
6	21.41016	0.62	28.60	16.62	29.22	17.24	60.00	50.00	-30.78	-32.76

REMARKS:

1. Q.P. and AV. are abbreviations of quasi-peak and average individually.
2. The emission levels of other frequencies were very low against the limit.
3. Margin value = Emission level - Limit value
4. Correction factor = Insertion loss + Cable loss
5. Emission Level = Correction Factor + Reading Value

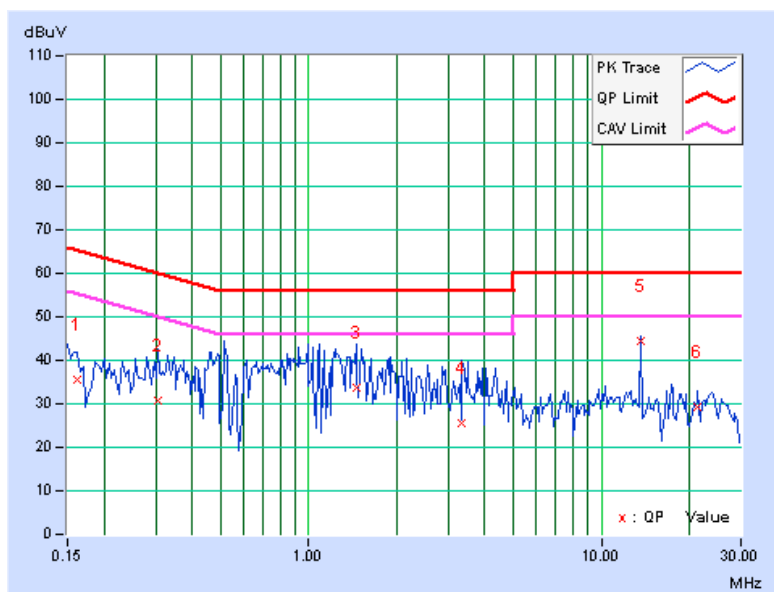

MODE B

PHASE	Line 1	6dB BANDWIDTH	9kHz
--------------	--------	----------------------	------

No	Freq.	Corr. Factor	Reading Value		Emission Level		Limit		Margin	
	[MHz]		[dB (uV)]		[dB (uV)]		[dB (uV)]		(dB)	
			Q.P.	AV.	Q.P.	AV.	Q.P.	AV.	Q.P.	AV.
1	0.19687	0.28	38.01	23.43	38.29	23.71	63.74	53.74	-25.45	-30.03
2	0.54063	0.31	39.85	26.46	40.16	26.77	56.00	46.00	-15.84	-19.23
3	0.98984	0.34	39.17	26.85	39.51	27.19	56.00	46.00	-16.49	-18.81
4	2.91406	0.39	35.29	23.29	35.68	23.68	56.00	46.00	-20.32	-22.32
5	10.30469	0.50	36.45	26.75	36.95	27.25	60.00	50.00	-23.05	-22.75
6	13.55859	0.52	42.24	39.52	42.76	40.04	60.00	50.00	-17.24	-9.96

REMARKS:

1. Q.P. and AV. are abbreviations of quasi-peak and average individually.
2. The emission levels of other frequencies were very low against the limit.
3. Margin value = Emission level - Limit value
4. Correction factor = Insertion loss + Cable loss
5. Emission Level = Correction Factor + Reading Value

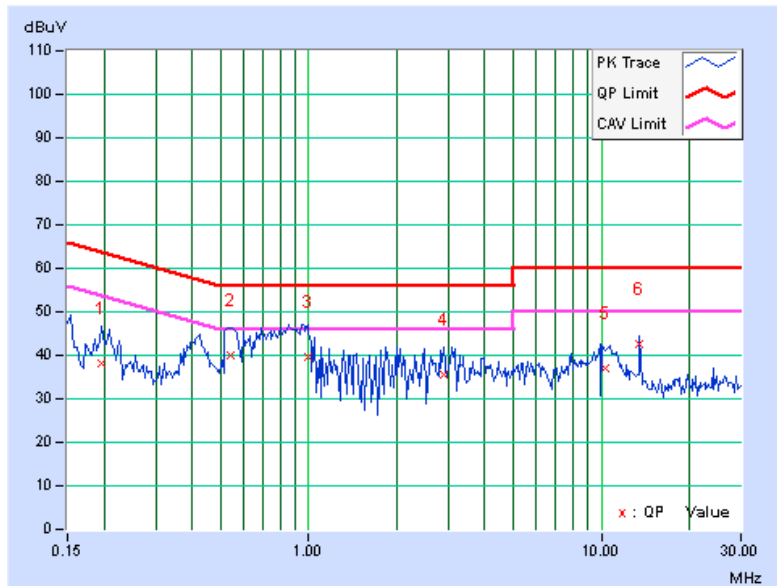



A D T

PHASE	Line 2	6dB BANDWIDTH	9kHz
-------	--------	---------------	------

No	Freq. [MHz]	Corr. Factor (dB)	Reading Value [dB (uV)]		Emission Level [dB (uV)]		Limit [dB (uV)]		Margin (dB)	
			Q.P.	AV.	Q.P.	AV.	Q.P.	AV.	Q.P.	AV.
			1	0.16953	0.27	34.75	24.34	35.02	24.61	64.98
2	0.44297	0.30	40.89	32.64	41.19	32.94	57.01	47.01	-15.81	-14.06
3	0.78672	0.33	35.41	24.38	35.74	24.71	56.00	46.00	-20.26	-21.29
4	2.01953	0.37	31.89	22.87	32.26	23.24	56.00	46.00	-23.74	-22.76
5	10.89063	0.53	34.43	23.53	34.96	24.06	60.00	50.00	-25.04	-25.94
6	13.56250	0.55	46.43	41.14	46.98	41.69	60.00	50.00	-13.02	-8.31

REMARKS:

1. Q.P. and AV. are abbreviations of quasi-peak and average individually.
2. The emission levels of other frequencies were very low against the limit.
3. Margin value = Emission level - Limit value
4. Correction factor = Insertion loss + Cable loss
5. Emission Level = Correction Factor + Reading Value

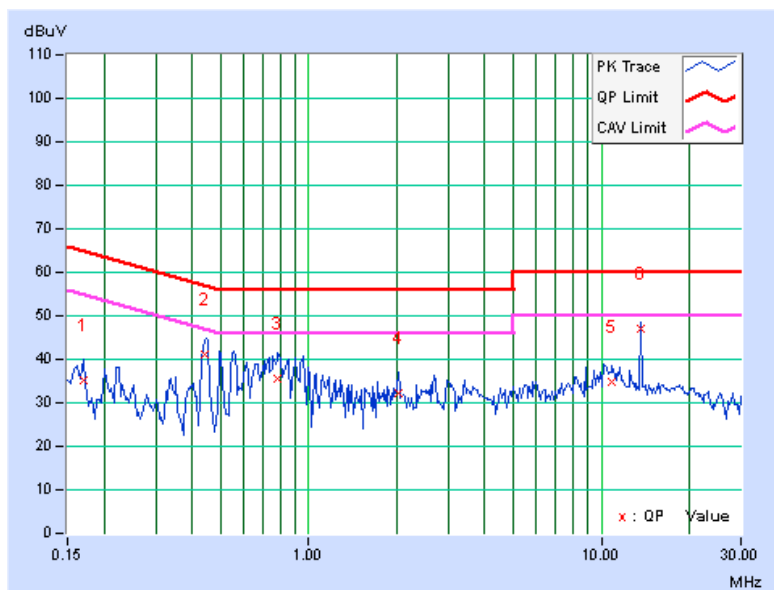

4.3 6dB BANDWIDTH MEASUREMENT

4.3.1 LIMITS OF 6dB BANDWIDTH MEASUREMENT

The minimum of 6dB Bandwidth Measurement is 0.5 MHz.

4.3.2 TEST SETUP

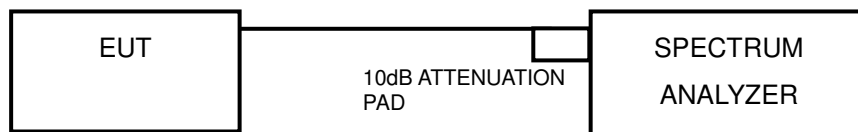

4.3.3 TEST INSTRUMENTS

Refer to section 4.1.2 to get information of above instrument.

4.3.4 TEST PROCEDURE

- Set resolution bandwidth (RBW) = 100kHz
- Set the video bandwidth (VBW) $\geq 3 \times$ RBW, Detector = Peak.
- Trace mode = max hold.
- Sweep = auto couple.
- Measure the maximum width of the emission that is constrained by the frequencies associated with the two amplitude points (upper and lower) that are attenuated by 6 dB relative to the maximum level measured in the fundamental emission

4.3.5 DEVIATION FROM TEST STANDARD

No deviation.

4.3.6 EUT OPERATING CONDITIONS

The software provided by client to enable the EUT under transmission condition continuously at lowest, middle and highest channel frequencies individually.



A D T

4.3.7 TEST RESULTS

802.11b

CHANNEL	FREQUENCY (MHz)	6dB BANDWIDTH (MHz)	MINIMUM LIMIT (MHz)	PASS / FAIL
1	2412	9.06	0.5	PASS
6	2437	9.09	0.5	PASS
11	2462	9.55	0.5	PASS

802.11g

CHANNEL	FREQUENCY (MHz)	6dB BANDWIDTH (MHz)	MINIMUM LIMIT (MHz)	PASS / FAIL
1	2412	16.40	0.5	PASS
6	2437	16.41	0.5	PASS
11	2462	16.36	0.5	PASS

802.11n (20MHz)

CHANNEL	FREQUENCY (MHz)	6dB BANDWIDTH (MHz)	MINIMUM LIMIT (MHz)	PASS / FAIL
1	2412	17.63	0.5	PASS
6	2437	17.63	0.5	PASS
11	2462	17.34	0.5	PASS



A D T

SPECTRUM PLOT OF WORST VALUE

802.11b

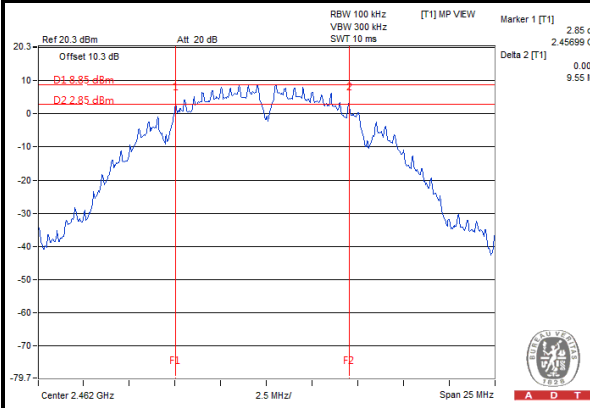

802.11g

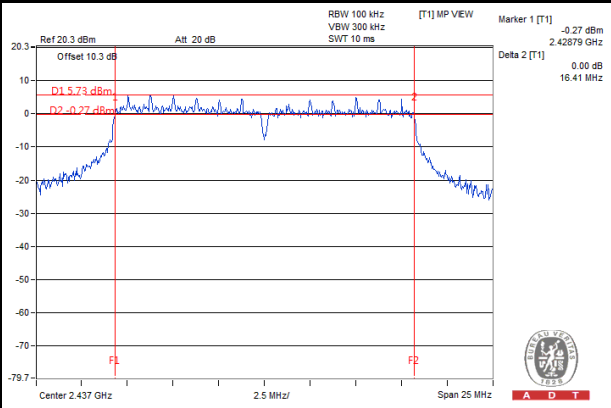

802.11n (20MHz)

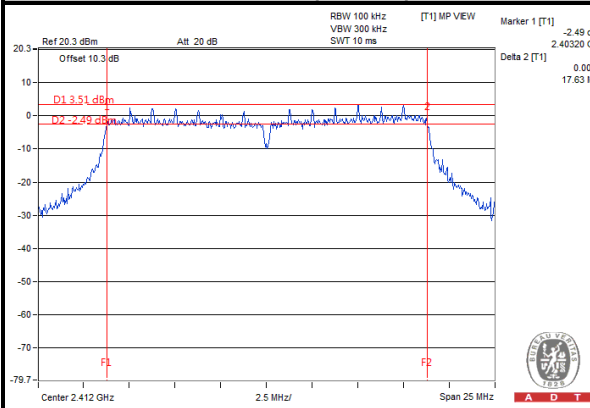

4.4 CONDUCTED OUTPUT POWER

4.4.1 LIMITS OF CONDUCTED OUTPUT POWER MEASUREMENT

For systems using digital modulation in the 2400–2483.5 MHz bands: 1 Watt (30dBm)

4.4.2 TEST SETUP

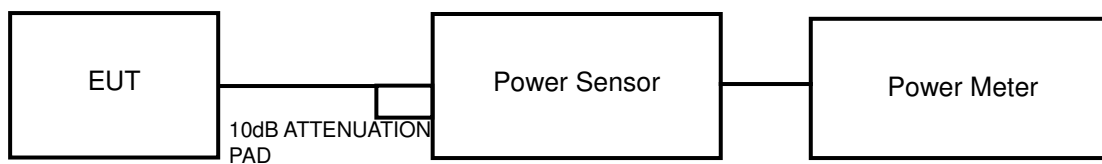

4.4.3 TEST INSTRUMENTS

Refer to section 4.1.2 to get information of above instrument.

4.4.4 TEST PROCEDURES

A peak power sensor was used on the output port of the EUT. A power meter was used to read the response of the peak power sensor. Record the peak power level.

4.4.5 DEVIATION FROM TEST STANDARD

No deviation.

4.4.6 EUT OPERATING CONDITIONS

Same as section 4.3.6.



A D T

4.4.7 TEST RESULTS

802.11b

CHANNEL	FREQUENCY (MHz)	PEAK POWER (mW)	PEAK POWER (dBm)	LIMIT (dBm)	PASS / FAIL
1	2412	118.58	20.74	30	PASS
6	2437	129.42	21.12	30	PASS
11	2462	125.60	20.99	30	PASS

802.11g

CHANNEL	FREQUENCY (MHz)	PEAK POWER (mW)	PEAK POWER (dBm)	LIMIT (dBm)	PASS / FAIL
1	2412	142.23	21.53	30	PASS
6	2437	205.12	23.12	30	PASS
11	2462	220.29	23.43	30	PASS

802.11n (20MHz)

CHANNEL	FREQUENCY (MHz)	PEAK POWER (mW)	PEAK POWER (dBm)	LIMIT (dBm)	PASS / FAIL
1	2412	162.55	22.11	30	PASS
6	2437	190.99	22.81	30	PASS
11	2462	168.27	22.26	30	PASS

4.5 POWER SPECTRAL DENSITY MEASUREMENT

4.5.1 LIMITS OF POWER SPECTRAL DENSITY MEASUREMENT

The Maximum of Power Spectral Density Measurement is 8dBm.

4.5.2 TEST SETUP

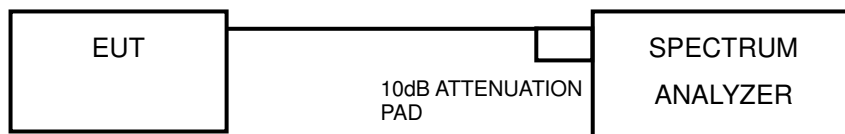

4.5.3 TEST INSTRUMENTS

Refer to section 4.1.2 to get information of above instrument.

4.5.4 TEST PROCEDURE

- Set the RBW = 3 kHz, VBW =10 kHz, Detector = peak.
- Sweep time = auto couple, Trace mode = max hold, allow trace to fully stabilize.
- Use the peak marker function to determine the maximum power level in any 100 kHz band segment within the fundamental EBW.

4.5.5 DEVIATION FROM TEST STANDARD

No deviation.

4.5.6 EUT OPERATING CONDITION

Same as section 4.3.6.



A D T

4.5.7 TEST RESULTS

802.11b

CHANNEL	FREQUENCY (MHz)	PSD (dBm/3kHz)	LIMIT (dBm/3kHz)	PASS / FAIL
1	2412	-3.87	8	PASS
6	2437	-4.49	8	PASS
11	2462	-5.75	8	PASS

802.11g

CHANNEL	FREQUENCY (MHz)	PSD (dBm/3kHz)	LIMIT (dBm/3kHz)	PASS / FAIL
1	2412	-10.08	8	PASS
6	2437	-9.96	8	PASS
11	2462	-8.78	8	PASS

802.11n (20MHz)

CHANNEL	FREQUENCY (MHz)	PSD (dBm/3kHz)	LIMIT (dBm/3kHz)	PASS / FAIL
1	2412	-10.22	8	PASS
6	2437	-9.08	8	PASS
11	2462	-11.64	8	PASS



A D T

SPECTRUM PLOT OF WORST VALUE

802.11b

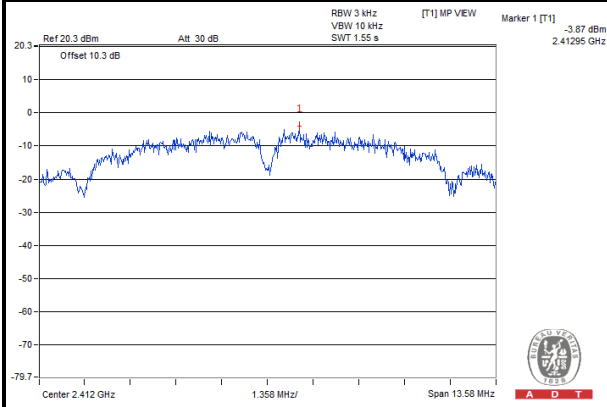

802.11g

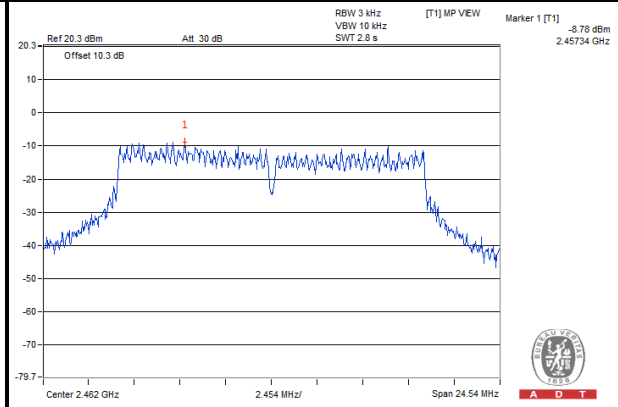

802.11n (20MHz)

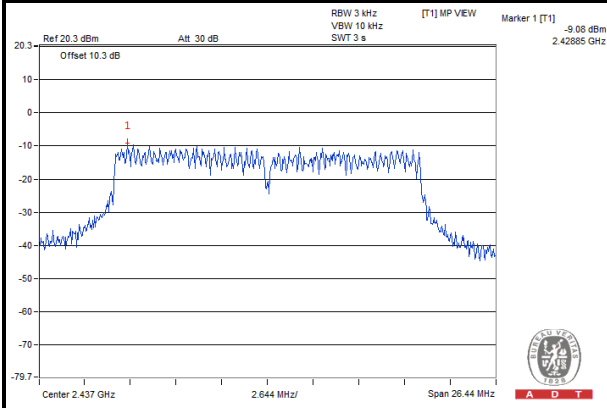

4.6 CONDUCTED OUT OF BAND EMISSION MEASUREMENT

4.6.1 LIMITS OF CONDUCTED OUT OF BAND EMISSION MEASUREMENT

Below -20dB of the highest emission level of operating band (in 100kHz Resolution Bandwidth).

4.6.2 TEST SETUP

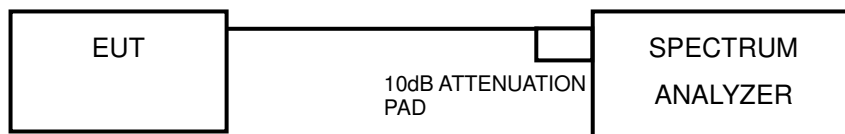

4.6.3 TEST INSTRUMENTS

Refer to section 4.1.2 to get information of above instrument.

4.6.4 TEST PROCEDURE

MEASUREMENT PROCEDURE REF

1. Set the RBW = 100 kHz.
2. Set the VBW \geq 300 kHz.
3. Detector = peak.
4. Sweep time = auto couple.
5. Trace mode = max hold.
6. Allow trace to fully stabilize.
7. Use the peak marker function to determine the maximum power level in any 100 kHz band segment within the fundamental EBW.

MEASUREMENT PROCEDURE OOB

1. Set RBW = 100 kHz.
2. Set VBW \geq 300 kHz.
3. Ensure that the number of measurement points \geq span/RBW
4. According to measurement points to set differ measurement span.
5. Detector = peak.
6. Trace Mode = max hold.
7. Sweep = auto couple.

4.6.5 DEVIATION FROM TEST STANDARD

No deviation.

4.6.6 EUT OPERATING CONDITION

Same as section 4.3.6.

4.6.7 TEST RESULTS

The spectrum plots are attached on the following images. D1 line indicates the highest level, and D2 line indicates the 20dB offset below D1. It shows compliance with the requirement.

802.11b

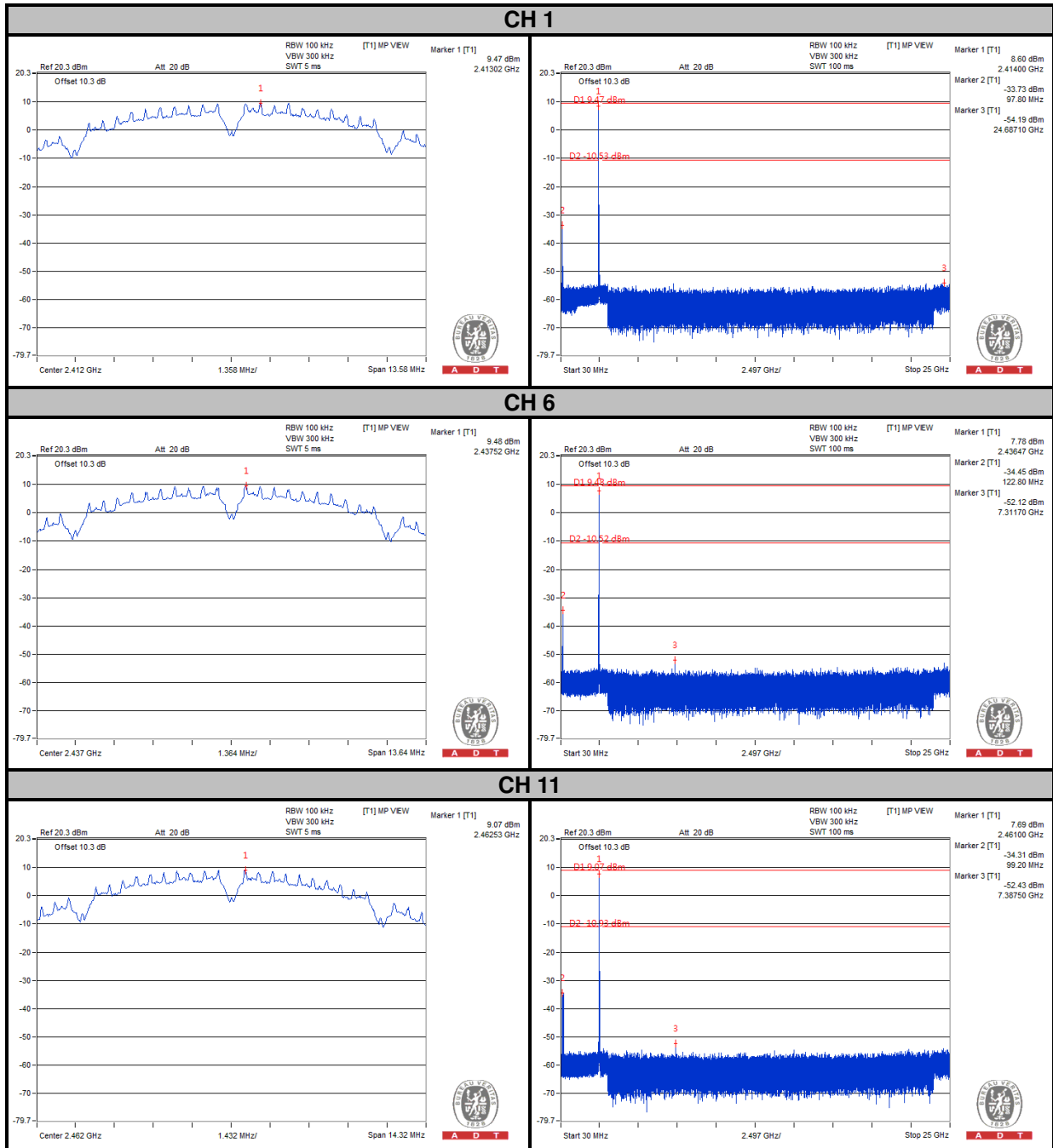



A D T

802.11g

CH 1

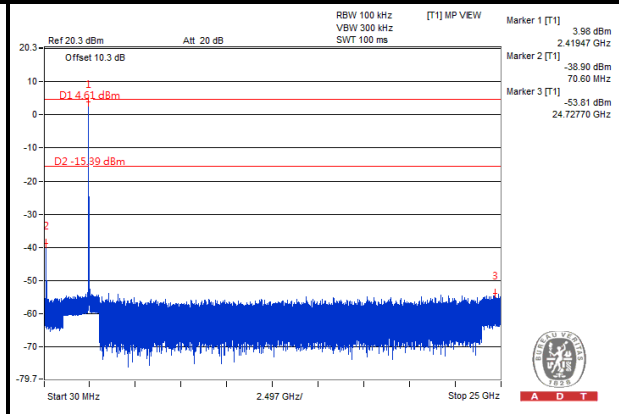
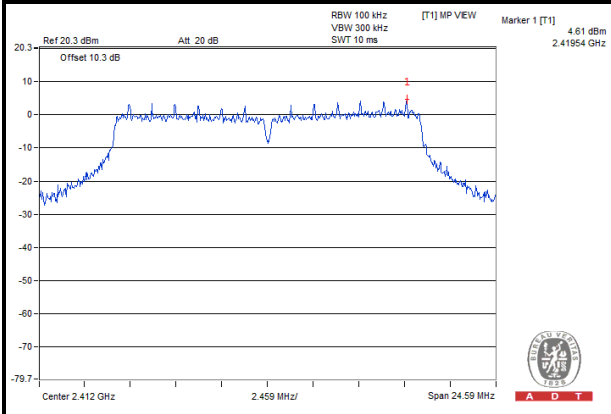

CH 6

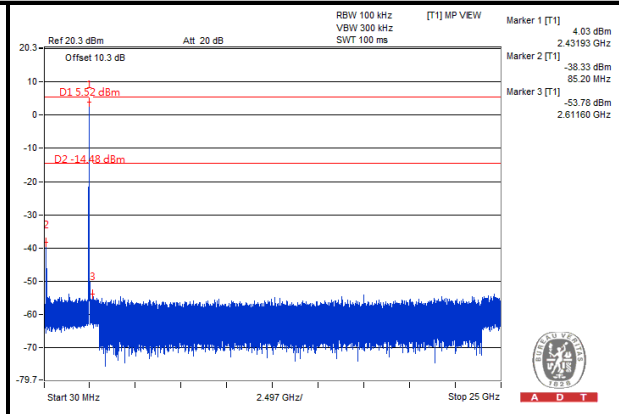
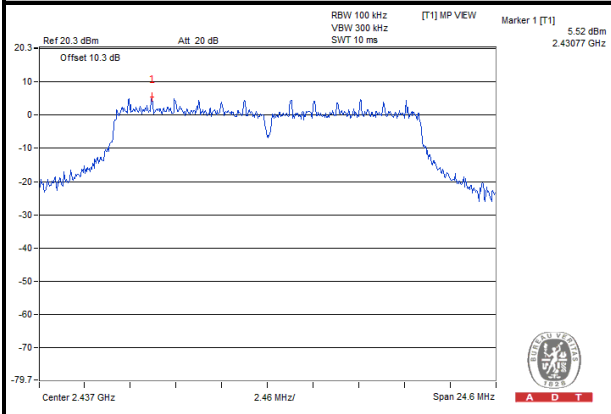

CH 11

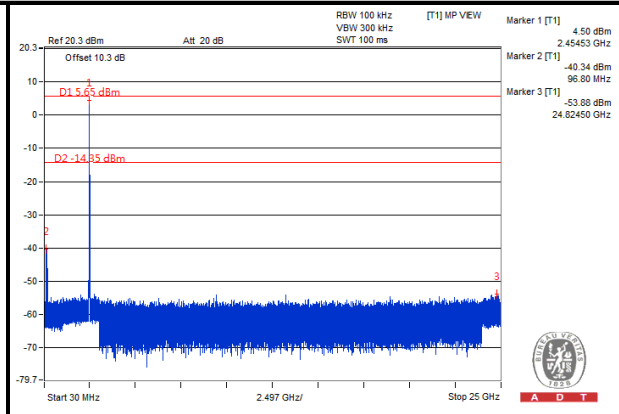
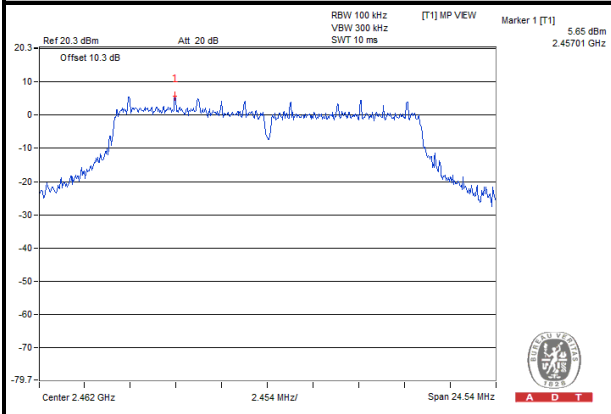



A D T

802.11n (20MHz)

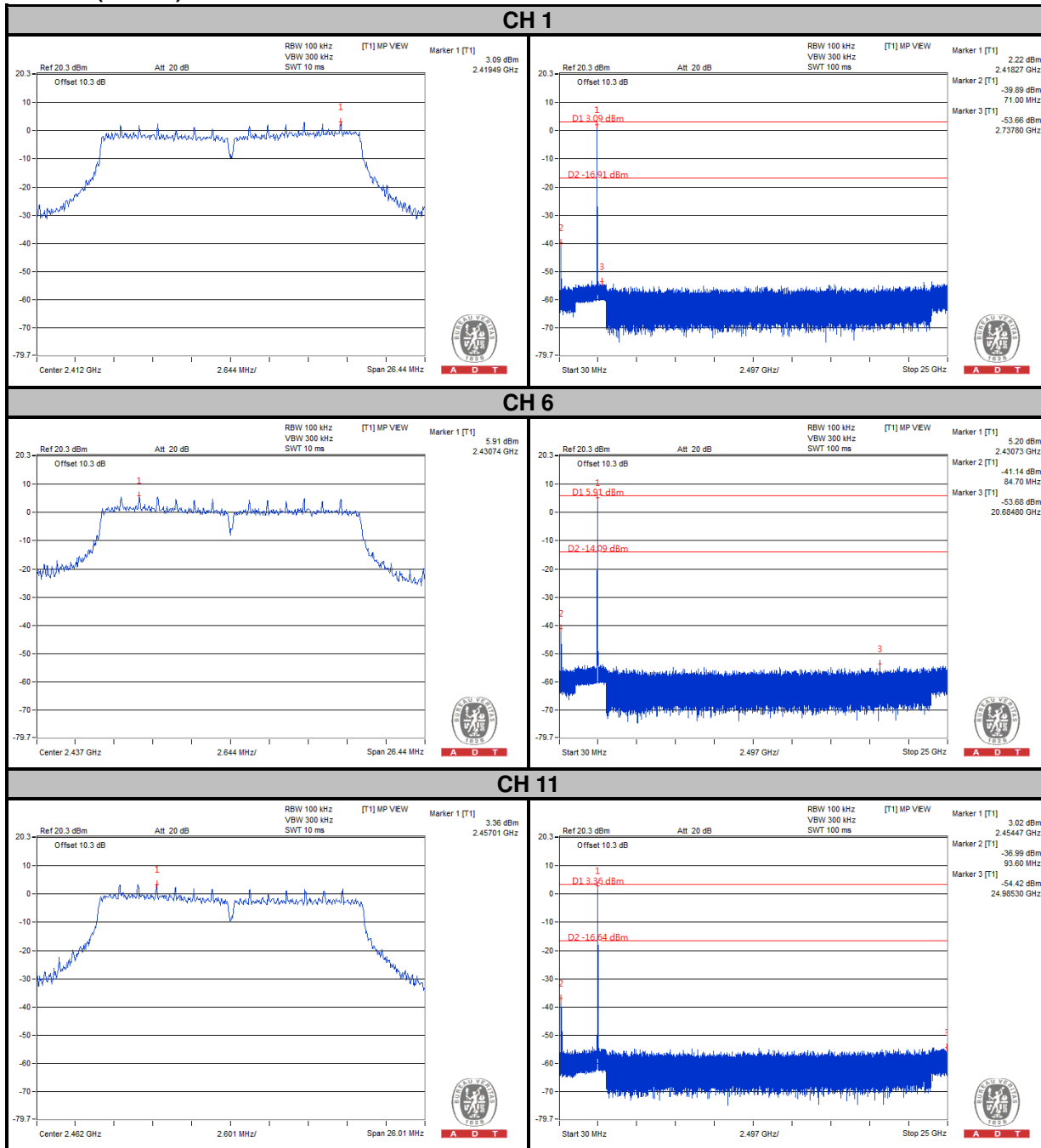

5. TEST TYPES AND RESULTS (FOR 5.0GHz BAND)

5.1 RADIATED EMISSION AND BANDEDGE MEASUREMENT

5.1.1 LIMITS OF RADIATED EMISSION AND BANDEDGE MEASUREMENT

Radiated emissions which fall in the restricted bands must comply with the radiated emission limits specified as below table. Other emissions shall be at least 20dB below the highest level of the desired power:

FREQUENCIES (MHz)	FIELD STRENGTH (microvolts/meter)	MEASUREMENT DISTANCE (meters)
0.009 ~ 0.490	2400/F(kHz)	300
0.490 ~ 1.705	24000/F(kHz)	30
1.705 ~ 30.0	30	30
30 ~ 88	100	3
88 ~ 216	150	3
216 ~ 960	200	3
Above 960	500	3

NOTE:

1. The lower limit shall apply at the transition frequencies.
2. Emission level (dBuV/m) = 20 log Emission level (uV/m).
3. For frequencies above 1000MHz, the field strength limits are based on average detector, however, the peak field strength of any emission shall not exceed the maximum permitted average limits, specified above by more than 20dB under any condition of modulation.



A D T

5.1.2 TEST INSTRUMENTS

Same as section 4.1.2.

5.1.3 TEST PROCEDURES

Same as section 4.1.3.

5.1.4 DEVIATION FROM TEST STANDARD

No deviation.

5.1.5 TEST SETUP

Same as section 4.1.5.

5.1.6 EUT OPERATING CONDITIONS

Same as section 4.1.6.



A D T

5.1.7 TEST RESULTS

ABOVE 1GHz WORST-CASE DATA :

MODE A

802.11a

EUT TEST CONDITION		MEASUREMENT DETAIL	
CHANNEL	Channel 149	FREQUENCY RANGE	1GHz ~ 40GHz
INPUT POWER	120Vac, 60 Hz	DETECTOR FUNCTION	Peak (PK) Average (AV)
ENVIRONMENTAL CONDITIONS	25deg. C, 65%RH	TESTED BY	Johnson Liao

ANTENNA POLARITY & TEST DISTANCE: HORIZONTAL AT 3 M										
FREQ. (MHz)	EMISSION LEVEL (dBuV/m)	READ LEVEL (dBuV)	LIMIT (dBuV/m)	MARGIN (dB)	ANTENNA FACTOR (dB/m)	CABLE LOSS (dB)	PREAMP FACTOR (dB)	ANTENNA HEIGHT (cm)	TABLE ANGLE (Degree)	REMARK
5725	49.14	49.02	76.93	-27.79	31.96	5.59	37.43	102	176	Average
5725	66.55	66.43	86.51	-19.96	31.96	5.59	37.43	102	176	Peak
5745	96.93	96.81			31.99	5.6	37.47	102	176	Average
5745	106.51	106.39			31.99	5.6	37.47	102	176	Peak
5825	37.92	37.69	76.93	-39.01	32.12	5.64	37.53	102	176	Average
5825	58.21	57.98	86.51	-28.3	32.12	5.64	37.53	102	176	Peak
ANTENNA POLARITY & TEST DISTANCE: VERTICAL AT 3 M										
FREQ. (MHz)	EMISSION LEVEL (dBuV/m)	READ LEVEL (dBuV)	LIMIT (dBuV/m)	MARGIN (dB)	ANTENNA FACTOR (dB/m)	CABLE LOSS (dB)	PREAMP FACTOR (dB)	ANTENNA HEIGHT (cm)	TABLE ANGLE (Degree)	REMARK
5725	44.82	44.7	72.25	-27.43	31.96	5.59	37.43	100	345	Average
5725	61.56	61.44	81.42	-19.86	31.96	5.59	37.43	100	345	Peak
5745	92.25	92.13			31.99	5.6	37.47	100	345	Average
5745	101.42	101.3			31.99	5.6	37.47	100	345	Peak
5825	38.17	37.94	72.25	-34.08	32.12	5.64	37.53	100	345	Average
5825	58.11	57.88	81.42	-23.31	32.12	5.64	37.53	100	345	Peak

REMARKS:

- Emission Level = Read Level + Antenna Factor + Cable Loss - Preamp Factor
Margin value = Emission level – Limit value
- 5745MHz: Fundamental frequency.
- 5725MHz & 5825MHz: Out of restricted band



A D T

EUT TEST CONDITION		MEASUREMENT DETAIL	
CHANNEL	Channel 157	FREQUENCY RANGE	1GHz ~ 40GHz
INPUT POWER	120Vac, 60 Hz	DETECTOR FUNCTION	Peak (PK) Average (AV)
ENVIRONMENTAL CONDITIONS	25deg. C, 65%RH	TESTED BY	Johnson Liao

ANTENNA POLARITY & TEST DISTANCE: HORIZONTAL AT 3 M

FREQ. (MHz)	EMISSION LEVEL (dBuV/m)	READ LEVEL (dBuV)	LIMIT (dBuV/m)	MARGIN (dB)	ANTENNA FACTOR (dB/m)	CABLE LOSS (dB)	PREAMP FACTOR (dB)	ANTENNA HEIGHT (cm)	TABLE ANGLE (Degree)	REMARK
5725	37.99	37.87	77.6	-39.61	31.96	5.59	37.43	100	178	Average
5725	58.44	58.32	87	-28.56	31.96	5.59	37.43	100	178	Peak
5785	97.6	97.48			32.04	5.62	37.54	100	178	Average
5785	107	106.88			32.04	5.62	37.54	100	178	Peak
5825	38.86	38.63	77.6	-38.74	32.12	5.64	37.53	100	178	Average
5825	58.5	58.27	87	-28.5	32.12	5.64	37.53	100	178	Peak

ANTENNA POLARITY & TEST DISTANCE: VERTICAL AT 3 M

FREQ. (MHz)	EMISSION LEVEL (dBuV/m)	READ LEVEL (dBuV)	LIMIT (dBuV/m)	MARGIN (dB)	ANTENNA FACTOR (dB/m)	CABLE LOSS (dB)	PREAMP FACTOR (dB)	ANTENNA HEIGHT (cm)	TABLE ANGLE (Degree)	REMARK
5725	37.7	37.58	72.96	-35.26	31.96	5.59	37.43	100	345	Average
5725	58.32	58.2	82.58	-24.26	31.96	5.59	37.43	100	345	Peak
5785	92.96	92.84			32.04	5.62	37.54	100	345	Average
5785	102.58	102.46			32.04	5.62	37.54	100	345	Peak
5825	38.18	37.95	72.96	-34.78	32.12	5.64	37.53	100	345	Average
5825	58.73	58.5	82.58	-23.85	32.12	5.64	37.53	100	345	Peak

REMARKS:

- Emission Level = Read Level + Antenna Factor + Cable Loss - Preamp Factor
Margin value = Emission level – Limit value
- 5785MHz: Fundamental frequency.
- 5725MHz & 5825MHz: Out of restricted band



A D T

EUT TEST CONDITION		MEASUREMENT DETAIL	
CHANNEL	Channel 161	FREQUENCY RANGE	1GHz ~ 40GHz
INPUT POWER	120Vac, 60 Hz	DETECTOR FUNCTION	Peak (PK) Average (AV)
ENVIRONMENTAL CONDITIONS	25deg. C, 65%RH	TESTED BY	Johnson Liao

ANTENNA POLARITY & TEST DISTANCE: HORIZONTAL AT 3 M

FREQ. (MHz)	EMISSION LEVEL (dBuV/m)	READ LEVEL (dBuV)	LIMIT (dBuV/m)	MARGIN (dB)	ANTENNA FACTOR (dB/m)	CABLE LOSS (dB)	PREAMP FACTOR (dB)	ANTENNA HEIGHT (cm)	TABLE ANGLE (Degree)	REMARK
5725	37.94	37.82	77.82	-39.88	31.96	5.59	37.43	100	171	Average
5725	58.7	58.58	87.09	-28.39	31.96	5.59	37.43	100	171	Peak
5805	97.82	97.63			32.1	5.63	37.54	100	171	Average
5805	107.09	106.9			32.1	5.63	37.54	100	171	Peak
5825	48.44	48.21	77.82	-29.38	32.12	5.64	37.53	100	171	Average
5825	67.43	67.2	87.09	-19.66	32.12	5.64	37.53	100	171	Peak

ANTENNA POLARITY & TEST DISTANCE: VERTICAL AT 3 M

FREQ. (MHz)	EMISSION LEVEL (dBuV/m)	READ LEVEL (dBuV)	LIMIT (dBuV/m)	MARGIN (dB)	ANTENNA FACTOR (dB/m)	CABLE LOSS (dB)	PREAMP FACTOR (dB)	ANTENNA HEIGHT (cm)	TABLE ANGLE (Degree)	REMARK
5725	37.82	37.7	72.91	-35.09	31.96	5.59	37.43	100	344	Average
5725	58.9	58.78	81.92	-23.02	31.96	5.59	37.43	100	344	Peak
5805	92.91	92.72			32.1	5.63	37.54	100	344	Average
5805	101.92	101.73			32.1	5.63	37.54	100	344	Peak
5825	44.18	43.95	72.91	-28.73	32.12	5.64	37.53	100	344	Average
5825	62.73	62.5	81.92	-19.19	32.12	5.64	37.53	100	344	Peak

REMARKS:

- Emission Level = Read Level + Antenna Factor + Cable Loss - Preamp Factor
Margin value = Emission level – Limit value
- 5805MHz: Fundamental frequency.
- 5725MHz & 5825MHz: Out of restricted band



A D T

802.11n (20MHz)

EUT TEST CONDITION		MEASUREMENT DETAIL	
CHANNEL	Channel 149	FREQUENCY RANGE	1GHz ~ 40GHz
INPUT POWER	120Vac, 60 Hz	DETECTOR FUNCTION	Peak (PK) Average (AV)
ENVIRONMENTAL CONDITIONS	25deg. C, 65%RH	TESTED BY	Johnson Liao

ANTENNA POLARITY & TEST DISTANCE: HORIZONTAL AT 3 M

FREQ. (MHz)	EMISSION LEVEL (dBuV/m)	READ LEVEL (dBuV)	LIMIT (dBuV/m)	MARGIN (dB)	ANTENNA FACTOR (dB/m)	CABLE LOSS (dB)	PREAMP FACTOR (dB)	ANTENNA HEIGHT (cm)	TABLE ANGLE (Degree)	REMARK
5725	49.72	49.6	77.26	-27.54	31.96	5.59	37.43	102	174	Average
5725	67.81	67.69	87.05	-19.24	31.96	5.59	37.43	102	174	Peak
5745	97.26	97.14			31.99	5.6	37.47	102	174	Average
5745	107.05	106.93			31.99	5.6	37.47	102	174	Peak
5825	37.9	37.67	77.26	-39.36	32.12	5.64	37.53	102	174	Average
5825	58.26	58.03	87.05	-28.79	32.12	5.64	37.53	102	174	Peak

ANTENNA POLARITY & TEST DISTANCE: VERTICAL AT 3 M

FREQ. (MHz)	EMISSION LEVEL (dBuV/m)	READ LEVEL (dBuV)	LIMIT (dBuV/m)	MARGIN (dB)	ANTENNA FACTOR (dB/m)	CABLE LOSS (dB)	PREAMP FACTOR (dB)	ANTENNA HEIGHT (cm)	TABLE ANGLE (Degree)	REMARK
5725	46.08	45.96	72.04	-25.96	31.96	5.59	37.43	100	348	Average
5725	64.16	64.04	82.06	-17.9	31.96	5.59	37.43	100	348	Peak
5745	92.04	91.92			31.99	5.6	37.47	100	348	Average
5745	102.06	101.94			31.99	5.6	37.47	100	348	Peak
5825	37.92	37.69	72.04	-34.12	32.12	5.64	37.53	100	348	Average
5825	58.33	58.1	82.06	-23.73	32.12	5.64	37.53	100	348	Peak

REMARKS:

- Emission Level = Read Level + Antenna Factor + Cable Loss - Preamp Factor
Margin value = Emission level – Limit value
- 5745MHz: Fundamental frequency.
- 5725MHz & 5825MHz: Out of restricted band



A D T

EUT TEST CONDITION		MEASUREMENT DETAIL	
CHANNEL	Channel 157	FREQUENCY RANGE	1GHz ~ 40GHz
INPUT POWER	120Vac, 60 Hz	DETECTOR FUNCTION	Peak (PK) Average (AV)
ENVIRONMENTAL CONDITIONS	25deg. C, 65%RH	TESTED BY	Johnson Liao

ANTENNA POLARITY & TEST DISTANCE: HORIZONTAL AT 3 M

FREQ. (MHz)	EMISSION LEVEL (dBuV/m)	READ LEVEL (dBuV)	LIMIT (dBuV/m)	MARGIN (dB)	ANTENNA FACTOR (dB/m)	CABLE LOSS (dB)	PREAMP FACTOR (dB)	ANTENNA HEIGHT (cm)	TABLE ANGLE (Degree)	REMARK
5725	37.98	37.86	77.73	-39.75	31.96	5.59	37.43	101	176	Average
5725	58.69	58.57	87.14	-28.45	31.96	5.59	37.43	101	176	Peak
5785	97.73	97.61			32.04	5.62	37.54	101	176	Average
5785	107.14	107.02			32.04	5.62	37.54	101	176	Peak
5825	38.98	38.75	77.73	-38.75	32.12	5.64	37.53	101	176	Average
5825	59.73	59.5	87.14	-27.41	32.12	5.64	37.53	101	176	Peak

ANTENNA POLARITY & TEST DISTANCE: VERTICAL AT 3 M

FREQ. (MHz)	EMISSION LEVEL (dBuV/m)	READ LEVEL (dBuV)	LIMIT (dBuV/m)	MARGIN (dB)	ANTENNA FACTOR (dB/m)	CABLE LOSS (dB)	PREAMP FACTOR (dB)	ANTENNA HEIGHT (cm)	TABLE ANGLE (Degree)	REMARK
5725	37.77	37.65	72.98	-35.21	31.96	5.59	37.43	100	348	Average
5725	57.67	57.55	82.13	-24.46	31.96	5.59	37.43	100	348	Peak
5785	92.98	92.86			32.04	5.62	37.54	100	348	Average
5785	102.13	102.01			32.04	5.62	37.54	100	348	Peak
5825	38.08	37.85	72.98	-34.9	32.12	5.64	37.53	100	348	Average
5825	57.93	57.7	82.13	-24.2	32.12	5.64	37.53	100	348	Peak

REMARKS:

- Emission Level = Read Level + Antenna Factor + Cable Loss - Preamp Factor
Margin value = Emission level – Limit value
- 5785MHz: Fundamental frequency.
- 5725MHz & 5825MHz: Out of restricted band



A D T

EUT TEST CONDITION		MEASUREMENT DETAIL	
CHANNEL	Channel 161	FREQUENCY RANGE	1GHz ~ 40GHz
INPUT POWER	120Vac, 60 Hz	DETECTOR FUNCTION	Peak (PK) Average (AV)
ENVIRONMENTAL CONDITIONS	25deg. C, 65%RH	TESTED BY	Johnson Liao

ANTENNA POLARITY & TEST DISTANCE: HORIZONTAL AT 3 M

FREQ. (MHz)	EMISSION LEVEL (dBuV/m)	READ LEVEL (dBuV)	LIMIT (dBuV/m)	MARGIN (dB)	ANTENNA FACTOR (dB/m)	CABLE LOSS (dB)	PREAMP FACTOR (dB)	ANTENNA HEIGHT (cm)	TABLE ANGLE (Degree)	REMARK
5725	37.9	37.78	77.76	-39.86	31.96	5.59	37.43	101	179	Average
5725	59.06	58.94	86.81	-27.75	31.96	5.59	37.43	101	179	Peak
5805	97.76	97.57			32.1	5.63	37.54	101	179	Average
5805	106.81	106.62			32.1	5.63	37.54	101	179	Peak
5825	49.46	49.23	77.76	-28.3	32.12	5.64	37.53	101	179	Average
5825	66.79	66.56	86.81	-20.02	32.12	5.64	37.53	101	179	Peak

ANTENNA POLARITY & TEST DISTANCE: VERTICAL AT 3 M

FREQ. (MHz)	EMISSION LEVEL (dBuV/m)	READ LEVEL (dBuV)	LIMIT (dBuV/m)	MARGIN (dB)	ANTENNA FACTOR (dB/m)	CABLE LOSS (dB)	PREAMP FACTOR (dB)	ANTENNA HEIGHT (cm)	TABLE ANGLE (Degree)	REMARK
5725	37.7	37.58	72.5	-34.8	31.96	5.59	37.43	100	344	Average
5725	58.36	58.24	81.32	-22.96	31.96	5.59	37.43	100	344	Peak
5805	92.5	92.31			32.1	5.63	37.54	100	344	Average
5805	101.32	101.13			32.1	5.63	37.54	100	344	Peak
5825	44.31	44.08	72.5	-28.19	32.12	5.64	37.53	100	344	Average
5825	64.87	64.64	81.32	-16.45	32.12	5.64	37.53	100	344	Peak

REMARKS:

- Emission Level = Read Level + Antenna Factor + Cable Loss - Preamp Factor
Margin value = Emission level – Limit value
- 5805MHz: Fundamental frequency.
- 5725MHz & 5825MHz: Out of restricted band



A D T

802.11n (40MHz)

EUT TEST CONDITION		MEASUREMENT DETAIL	
CHANNEL	Channel 151	FREQUENCY RANGE	1GHz ~ 40GHz
INPUT POWER	120Vac, 60 Hz	DETECTOR FUNCTION	Peak (PK) Average (AV)
ENVIRONMENTAL CONDITIONS	25deg. C, 65%RH	TESTED BY	Johnson Liao

ANTENNA POLARITY & TEST DISTANCE: HORIZONTAL AT 3 M

FREQ. (MHz)	EMISSION LEVEL (dBuV/m)	READ LEVEL (dBuV)	LIMIT (dBuV/m)	MARGIN (dB)	ANTENNA FACTOR (dB/m)	CABLE LOSS (dB)	PREAMP FACTOR (dB)	ANTENNA HEIGHT (cm)	TABLE ANGLE (Degree)	REMARK
5725	50.83	50.71	73.98	-23.15	31.96	5.59	37.43	101	178	Average
5725	63.87	63.75	83.23	-19.36	31.96	5.59	37.43	101	178	Peak
5755	93.98	93.84			32.01	5.6	37.47	101	178	Average
5755	103.23	103.09			32.01	5.6	37.47	101	178	Peak
5825	39.32	39.09	73.98	-34.66	32.12	5.64	37.53	101	178	Average
5825	57.88	57.65	83.23	-25.35	32.12	5.64	37.53	101	178	Peak

ANTENNA POLARITY & TEST DISTANCE: VERTICAL AT 3 M

FREQ. (MHz)	EMISSION LEVEL (dBuV/m)	READ LEVEL (dBuV)	LIMIT (dBuV/m)	MARGIN (dB)	ANTENNA FACTOR (dB/m)	CABLE LOSS (dB)	PREAMP FACTOR (dB)	ANTENNA HEIGHT (cm)	TABLE ANGLE (Degree)	REMARK
5725	46.96	46.84	69.66	-22.7	31.96	5.59	37.43	100	346	Average
5725	62.24	62.12	79.55	-17.31	31.96	5.59	37.43	100	346	Peak
5755	89.66	89.52			32.01	5.6	37.47	100	346	Average
5755	99.55	99.41			32.01	5.6	37.47	100	346	Peak
5825	38.5	38.27	69.66	-31.16	32.12	5.64	37.53	100	346	Average
5825	58.25	58.02	79.55	-21.3	32.12	5.64	37.53	100	346	Peak

REMARKS:

- Emission Level = Read Level + Antenna Factor + Cable Loss - Preamp Factor
Margin value = Emission level – Limit value
- 5755MHz: Fundamental frequency.
- 5725MHz & 5825MHz: Out of restricted band



A D T

EUT TEST CONDITION		MEASUREMENT DETAIL	
CHANNEL	Channel 159	FREQUENCY RANGE	1GHz ~ 40GHz
INPUT POWER	120Vac, 60 Hz	DETECTOR FUNCTION	Peak (PK) Average (AV)
ENVIRONMENTAL CONDITIONS	25deg. C, 65%RH	TESTED BY	Johnson Liao

ANTENNA POLARITY & TEST DISTANCE: HORIZONTAL AT 3 M

FREQ. (MHz)	EMISSION LEVEL (dBuV/m)	READ LEVEL (dBuV)	LIMIT (dBuV/m)	MARGIN (dB)	ANTENNA FACTOR (dB/m)	CABLE LOSS (dB)	PREAMP FACTOR (dB)	ANTENNA HEIGHT (cm)	TABLE ANGLE (Degree)	REMARK
5725	38.97	38.85	74.79	-35.82	31.96	5.59	37.43	100	176	Average
5725	58.08	57.96	83.86	-25.78	31.96	5.59	37.43	100	176	Peak
5795	94.79	94.63			32.07	5.63	37.54	100	176	Average
5795	103.86	103.7			32.07	5.63	37.54	100	176	Peak
5825	50.71	50.48	74.79	-24.08	32.12	5.64	37.53	100	176	Average
5825	69.1	68.87	83.86	-14.76	32.12	5.64	37.53	100	176	Peak

ANTENNA POLARITY & TEST DISTANCE: VERTICAL AT 3 M

FREQ. (MHz)	EMISSION LEVEL (dBuV/m)	READ LEVEL (dBuV)	LIMIT (dBuV/m)	MARGIN (dB)	ANTENNA FACTOR (dB/m)	CABLE LOSS (dB)	PREAMP FACTOR (dB)	ANTENNA HEIGHT (cm)	TABLE ANGLE (Degree)	REMARK
5725	38.47	38.35	70.41	-31.94	31.96	5.59	37.43	100	349	Average
5725	58.55	58.43	79.38	-20.83	31.96	5.59	37.43	100	349	Peak
5795	90.41	90.25			32.07	5.63	37.54	100	349	Average
5795	99.38	99.22			32.07	5.63	37.54	100	349	Peak
5825	45.33	45.1	70.41	-25.08	32.12	5.64	37.53	100	349	Average
5825	63.82	63.59	79.38	-15.56	32.12	5.64	37.53	100	349	Peak

REMARKS:

- Emission Level = Read Level + Antenna Factor + Cable Loss - Preamp Factor
Margin value = Emission level – Limit value
- 5795MHz: Fundamental frequency.
- 5725MHz & 5825MHz: Out of restricted band



A D T

MODE B

802.11n (40MHz)

EUT TEST CONDITION		MEASUREMENT DETAIL	
CHANNEL	Channel 159	FREQUENCY RANGE	1GHz ~ 40GHz
INPUT POWER	120Vac, 60 Hz	DETECTOR FUNCTION	Peak (PK) Average (AV)
ENVIRONMENTAL CONDITIONS	25deg. C, 65%RH	TESTED BY	Johnson Liao

ANTENNA POLARITY & TEST DISTANCE: HORIZONTAL AT 3 M

FREQ. (MHz)	EMISSION LEVEL (dBuV/m)	READ LEVEL (dBuV)	LIMIT (dBuV/m)	MARGIN (dB)	ANTENNA FACTOR (dB/m)	CABLE LOSS (dB)	PREAMP FACTOR (dB)	ANTENNA HEIGHT (cm)	TABLE ANGLE (Degree)	REMARK
5725	40.35	40.23	73.82	-33.47	31.96	5.59	37.43	137	219	Average
5725	58.85	58.73	82.99	-24.14	31.96	5.59	37.43	137	219	Peak
5795	93.82	93.66			32.07	5.63	37.54	137	219	Average
5795	102.99	102.83			32.07	5.63	37.54	137	219	Peak
5825	53.86	53.63	73.82	-19.96	32.12	5.64	37.53	137	219	Average
5825	61.41	61.18	82.99	-21.58	32.12	5.64	37.53	137	219	Peak

ANTENNA POLARITY & TEST DISTANCE: VERTICAL AT 3 M

FREQ. (MHz)	EMISSION LEVEL (dBuV/m)	READ LEVEL (dBuV)	LIMIT (dBuV/m)	MARGIN (dB)	ANTENNA FACTOR (dB/m)	CABLE LOSS (dB)	PREAMP FACTOR (dB)	ANTENNA HEIGHT (cm)	TABLE ANGLE (Degree)	REMARK
5725	39.48	39.36	70.44	-30.96	31.96	5.59	37.43	100	347	Average
5725	57.96	57.84	79.3	-21.34	31.96	5.59	37.43	100	347	Peak
5795	90.44	90.28			32.07	5.63	37.54	100	347	Average
5795	99.3	99.14			32.07	5.63	37.54	100	347	Peak
5825	50.89	50.66	70.44	-19.55	32.12	5.64	37.53	100	347	Average
5825	65.39	65.16	79.3	-13.91	32.12	5.64	37.53	100	347	Peak

REMARKS:

- Emission Level = Read Level + Antenna Factor + Cable Loss - Preamp Factor
Margin value = Emission level – Limit value
- 5795MHz: Fundamental frequency.
- 5725MHz & 5825MHz: Out of restricted band



A D T

BELOW 1GHz WORST-CASE DATA :

802.11n (40MHz)

EUT TEST CONDITION		MEASUREMENT DETAIL	
CHANNEL	Channel 159	FREQUENCY RANGE	30MHz ~ 1GHz
INPUT POWER	120Vac, 60 Hz	DETECTOR FUNCTION	Peak (PK)
ENVIRONMENTAL CONDITIONS	25deg. C, 65%RH	TESTED BY	Johnson Liao

ANTENNA POLARITY & TEST DISTANCE: HORIZONTAL AT 3 M										
FREQ. (MHz)	EMISSION LEVEL (dBuV/m)	READ LEVEL (dBuV)	LIMIT (dBuV/m)	MARGIN (dB)	ANTENNA FACTOR (dB/m)	CABLE LOSS (dB)	PREAMP FACTOR (dB)	ANTENNA HEIGHT (cm)	TABLE ANGLE (Degree)	REMARK
105.33	24.22	45.39	43.5	-19.28	9.62	1.1	31.89	100	95	Peak
140.7	25.37	43.34	43.5	-18.13	12.37	1.3	31.64	100	209	Peak
217.65	21.22	41.12	46	-24.78	10.09	1.68	31.67	100	213	Peak
383.3	20.98	35.66	46	-25.02	14.94	2.36	31.98	100	142	Peak
610.1	24.57	33.8	46	-21.43	19.73	3.12	32.08	100	244	Peak
743.1	26.11	32.57	46	-19.89	21.42	3.55	31.43	100	208	Peak
ANTENNA POLARITY & TEST DISTANCE: VERTICAL AT 3 M										
FREQ. (MHz)	EMISSION LEVEL (dBuV/m)	READ LEVEL (dBuV)	LIMIT (dBuV/m)	MARGIN (dB)	ANTENNA FACTOR (dB/m)	CABLE LOSS (dB)	PREAMP FACTOR (dB)	ANTENNA HEIGHT (cm)	TABLE ANGLE (Degree)	REMARK
30.77	35.82	54.23	40	-4.18	12.14	0.57	31.12	100	211	Peak
58.08	29.25	47.64	40	-10.75	12.15	0.81	31.35	100	207	Peak
140.16	22.11	40.08	43.5	-21.39	12.37	1.3	31.64	100	183	Peak
538	22.01	32.63	46	-23.99	18.19	2.91	31.72	100	281	Peak
648.6	24.1	32.69	46	-21.9	20.2	3.24	32.03	100	102	Peak
754.3	26.26	32.46	46	-19.74	21.59	3.58	31.37	100	253	Peak

REMARKS: Emission Level = Read Level + Antenna Factor + Cable Loss - Preamp Factor

Margin value = Emission level – Limit value

5.2 CONDUCTED EMISSION MEASUREMENT

5.2.1 LIMITS OF CONDUCTED EMISSION MEASUREMENT

FREQUENCY OF EMISSION (MHz)	CONDUCTED LIMIT (dB μ V)	
	Quasi-peak	Average
0.15 ~ 0.5	66 to 56	56 to 46
0.5 ~ 5	56	46
5 ~ 30	60	50

- NOTE:**
1. The lower limit shall apply at the transition frequencies.
 2. The limit decreases in line with the logarithm of the frequency in the range of 0.15 to 0.50MHz.
 3. All emanations from a class A/B digital device or system, including any network of conductors and apparatus connected thereto, shall not exceed the level of field strengths specified above.

5.2.2 TEST INSTRUMENTS

Same as section 4.2.2.

5.2.3 TEST PROCEDURES

Same as section 4.2.3.

5.2.4 DEVIATION FROM TEST STANDARD

No deviation.

5.2.5 TEST SETUP

Same as section 4.2.5.

5.2.6 EUT OPERATING CONDITIONS

Same as section 4.1.6.

5.2.7 TEST RESULTS

CONDUCTED WORST-CASE DATA :

MODE A

PHASE	Line 1	6dB BANDWIDTH	9kHz
-------	--------	---------------	------

No	Freq. [MHz]	Corr. Factor (dB)	Reading Value [dB (uV)]		Emission Level [dB (uV)]		Limit [dB (uV)]		Margin (dB)	
			Q.P.	AV.	Q.P.	AV.	Q.P.	AV.	Q.P.	AV.
			1	0.20469	0.28	36.00	10.35	36.28	10.63	63.42
2	0.50938	0.31	43.57	31.44	43.88	31.75	56.00	46.00	-12.12	-14.25
3	1.27344	0.35	39.69	25.43	40.04	25.78	56.00	46.00	-15.96	-20.22
4	1.74219	0.35	35.97	28.08	36.32	28.43	56.00	46.00	-19.68	-17.57
5	13.56250	0.52	53.40	46.45	53.92	46.97	60.00	50.00	-6.08	-3.03
6	21.29688	0.58	30.96	16.93	31.54	17.51	60.00	50.00	-28.46	-32.49

REMARKS:

1. Q.P. and AV. are abbreviations of quasi-peak and average individually.
2. The emission levels of other frequencies were very low against the limit.
3. Margin value = Emission level - Limit value
4. Correction factor = Insertion loss + Cable loss
5. Emission Level = Correction Factor + Reading Value

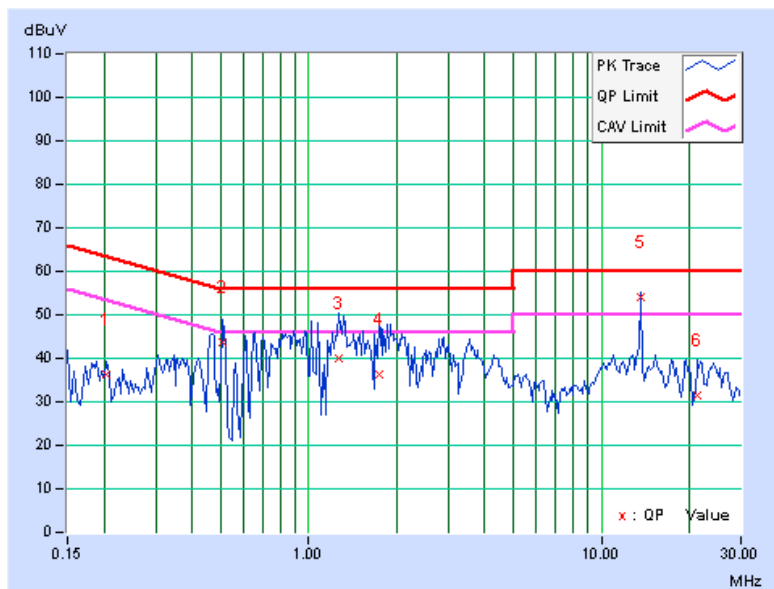

PHASE	Line 2	6dB BANDWIDTH	9kHz
-------	--------	---------------	------

No	Freq. [MHz]	Corr. Factor (dB)	Reading Value [dB (uV)]		Emission Level [dB (uV)]		Limit [dB (uV)]		Margin (dB)	
			Q.P.	AV.	Q.P.	AV.	Q.P.	AV.	Q.P.	AV.
			1	0.16953	0.27	34.95	16.06	35.22	16.33	64.98
2	0.30625	0.29	31.64	15.99	31.93	16.28	60.07	50.07	-28.14	-33.79
3	0.50000	0.31	21.26	9.03	21.57	9.34	56.00	46.00	-34.43	-36.66
4	2.26172	0.38	31.68	17.63	32.06	18.01	56.00	46.00	-23.94	-27.99
5	13.55859	0.55	43.68	41.81	44.23	42.36	60.00	50.00	-15.77	-7.64
6	23.48047	0.59	26.49	18.34	27.08	18.93	60.00	50.00	-32.92	-31.07

REMARKS:

1. Q.P. and AV. are abbreviations of quasi-peak and average individually.
2. The emission levels of other frequencies were very low against the limit.
3. Margin value = Emission level - Limit value
4. Correction factor = Insertion loss + Cable loss
5. Emission Level = Correction Factor + Reading Value

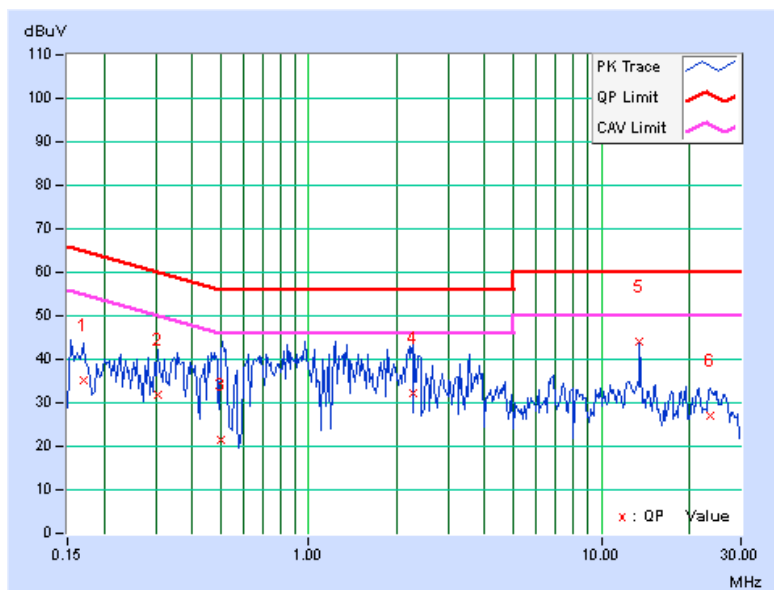

MODE B

PHASE	Line 1	6dB BANDWIDTH	9kHz
--------------	--------	----------------------	------

No	Freq. [MHz]	Corr. Factor (dB)	Reading Value [dB (uV)]		Emission Level [dB (uV)]		Limit [dB (uV)]		Margin (dB)	
			Q.P.	AV.	Q.P.	AV.	Q.P.	AV.	Q.P.	AV.
			1	0.19687	0.28	37.05	23.85	37.33	24.13	63.74
2	0.51328	0.31	35.57	19.40	35.88	19.71	56.00	46.00	-20.12	-26.29
3	0.89219	0.33	38.47	28.22	38.80	28.55	56.00	46.00	-17.20	-17.45
4	2.08203	0.36	35.74	22.93	36.10	23.29	56.00	46.00	-19.90	-22.71
5	10.30078	0.50	35.99	26.98	36.49	27.48	60.00	50.00	-23.51	-22.52
6	13.56250	0.52	47.63	42.88	48.15	43.40	60.00	50.00	-11.85	-6.60

REMARKS:

1. Q.P. and AV. are abbreviations of quasi-peak and average individually.
2. The emission levels of other frequencies were very low against the limit.
3. Margin value = Emission level - Limit value
4. Correction factor = Insertion loss + Cable loss
5. Emission Level = Correction Factor + Reading Value

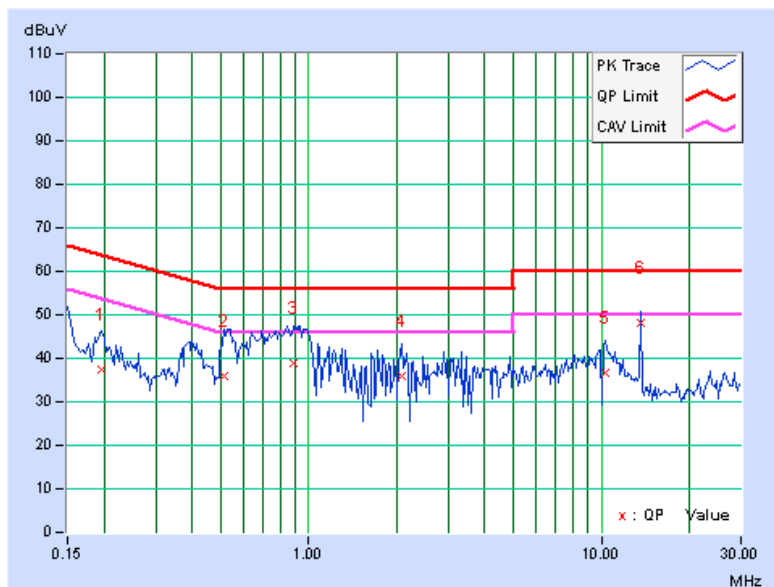

PHASE	Line 2	6dB BANDWIDTH	9kHz
-------	--------	---------------	------

No	Freq. [MHz]	Corr. Factor (dB)	Reading Value [dB (uV)]		Emission Level [dB (uV)]		Limit [dB (uV)]		Margin (dB)	
			Q.P.	AV.	Q.P.	AV.	Q.P.	AV.	Q.P.	AV.
			1	0.18125	0.27	30.89	18.14	31.16	18.41	64.43
2	0.44688	0.30	40.78	33.07	41.08	33.37	56.93	46.93	-15.85	-13.56
3	0.54844	0.31	38.21	28.50	38.52	28.81	56.00	46.00	-17.48	-17.19
4	0.95469	0.34	36.55	27.55	36.89	27.89	56.00	46.00	-19.11	-18.11
5	10.55469	0.52	33.04	24.81	33.56	25.33	60.00	50.00	-26.44	-24.67
6	13.56250	0.55	46.19	41.39	46.74	41.94	60.00	50.00	-13.26	-8.06

REMARKS:

1. Q.P. and AV. are abbreviations of quasi-peak and average individually.
2. The emission levels of other frequencies were very low against the limit.
3. Margin value = Emission level - Limit value
4. Correction factor = Insertion loss + Cable loss
5. Emission Level = Correction Factor + Reading Value

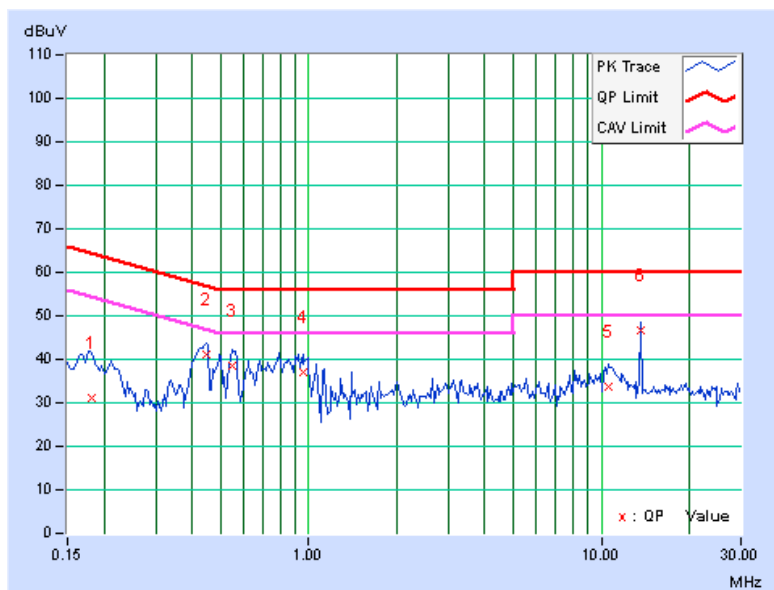



A D T

5.3 6dB BANDWIDTH MEASUREMENT

5.3.1 LIMITS OF 6dB BANDWIDTH MEASUREMENT

The minimum of 6dB Bandwidth Measurement is 0.5MHz.

5.3.2 TEST SETUP

Same as section 4.3.2.

5.3.3 TEST INSTRUMENTS

Refer to section 4.1.2 to get information of above instrument.

5.3.4 TEST PROCEDURE

Same as section 4.3.4.

5.3.5 DEVIATION FROM TEST STANDARD

No deviation.

5.3.6 EUT OPERATING CONDITIONS

Same as section 4.3.6.



A D T

5.3.7 TEST RESULTS

802.11a

CHANNEL	FREQUENCY (MHz)	6dB BANDWIDTH (MHz)	MINIMUM LIMIT (MHz)	PASS / FAIL
149	5745	16.41	0.5	PASS
157	5785	16.41	0.5	PASS
161	5805	16.40	0.5	PASS

802.11n (20MHz)

CHANNEL	FREQUENCY (MHz)	6dB BANDWIDTH (MHz)	MINIMUM LIMIT (MHz)	PASS / FAIL
149	5745	17.63	0.5	PASS
157	5785	17.62	0.5	PASS
161	5805	17.63	0.5	PASS

802.11n (40MHz)

CHANNEL	FREQUENCY (MHz)	6dB BANDWIDTH (MHz)	MINIMUM LIMIT (MHz)	PASS / FAIL
151	5755	35.26	0.5	PASS
159	5795	35.24	0.5	PASS



A D T

SPECTRUM PLOT OF WORST VALUE

802.11a

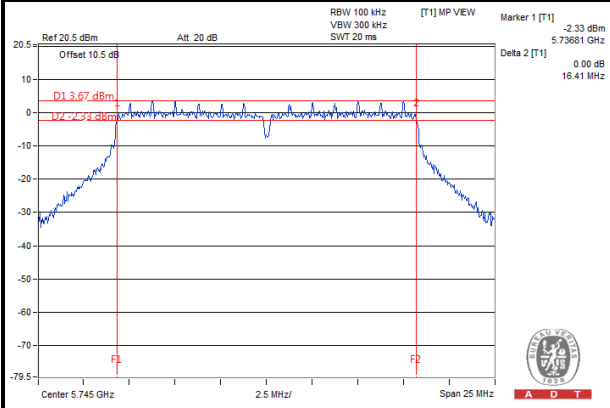

802.11n (20MHz)

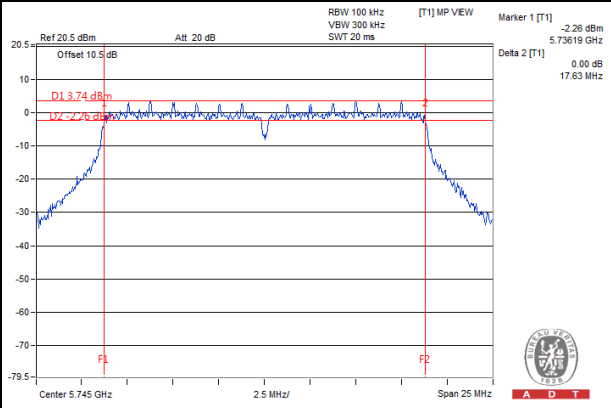

802.11n (40MHz)

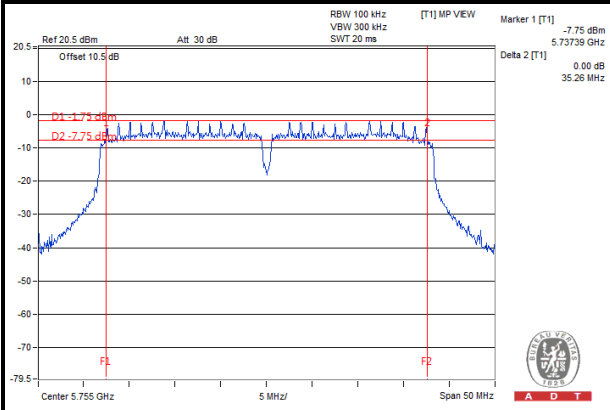

5.4 MAXIMUM OUTPUT POWER

5.4.1 LIMITS OF MAXIMUM OUTPUT POWER MEASUREMENT

For systems using digital modulation in the 5725–5850 MHz bands: 1 Watt (30dBm)

5.4.2 TEST SETUP

Same as section 4.4.2.

5.4.3 INSTRUMENTS

Refer to section 4.1.2 to get information of above instrument.

5.4.4 TEST PROCEDURES

Same as section 4.4.4.

5.4.5 DEVIATION FROM TEST STANDARD

No deviation.

5.4.6 EUT OPERATING CONDITIONS

Same as section 4.3.6.



A D T

5.4.7 TEST RESULTS

802.11a

CHANNEL	FREQUENCY (MHz)	PEAK POWER (mW)	PEAK POWER (dBm)	LIMIT (dBm)	PASS / FAIL
149	5745	308.32	24.89	30	PASS
157	5785	290.40	24.63	30	PASS
161	5805	291.74	24.65	30	PASS

802.11n (20MHz)

CHANNEL	FREQUENCY (MHz)	PEAK POWER (mW)	PEAK POWER (dBm)	LIMIT (dBm)	PASS / FAIL
149	5745	302.69	24.81	30	PASS
157	5785	290.40	24.63	30	PASS
161	5805	293.09	24.67	30	PASS

802.11n (40MHz)

CHANNEL	FREQUENCY (MHz)	PEAK POWER (mW)	PEAK POWER (dBm)	LIMIT (dBm)	PASS / FAIL
151	5755	195.43	22.91	30	PASS
159	5795	198.61	22.98	30	PASS



A D T

5.5 POWER SPECTRAL DENSITY MEASUREMENT

5.5.1 LIMITS OF POWER SPECTRAL DENSITY MEASUREMENT

The Maximum of Power Spectral Density Measurement is 8dBm.

5.5.2 TEST SETUP

Same as section 4.5.2.

5.5.3 TEST INSTRUMENTS

Refer to section 4.1.2 to get information of above instrument.

5.5.4 TEST PROCEDURE.

Same as section 4.5.4.

5.5.5 DEVIATION FROM TEST STANDARD

No deviation.

5.5.6 EUT OPERATING CONDITION

Same as section 4.3.6.

5.5.7 TEST RESULTS

802.11a

CHANNEL	FREQUENCY (MHz)	PSD (dBm/3kHz)	LIMIT (dBm/3kHz)	PASS / FAIL
149	5745	-10.64	8	PASS
157	5785	-10.41	8	PASS
161	5805	-10.16	8	PASS

802.11n (20MHz)

CHANNEL	FREQUENCY (MHz)	PSD (dBm/3kHz)	LIMIT (dBm/3kHz)	PASS / FAIL
149	5745	-10.08	8	PASS
157	5785	-9.85	8	PASS
161	5805	-9.95	8	PASS

802.11n (40MHz)

CHANNEL	FREQUENCY (MHz)	PSD (dBm/3kHz)	LIMIT (dBm/3kHz)	PASS / FAIL
151	5755	-15.00	8	PASS
159	5795	-15.95	8	PASS



A D T

SPECTRUM PLOT OF WORST VALUE

802.11a

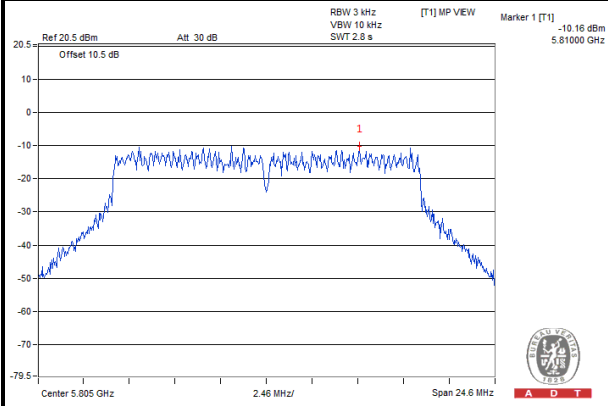

802.11n (20MHz)

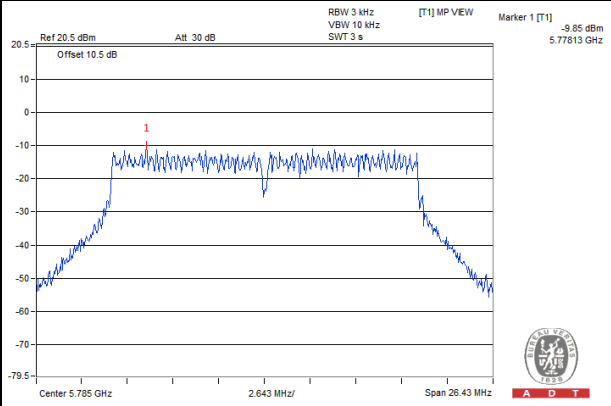

802.11n (40MHz)

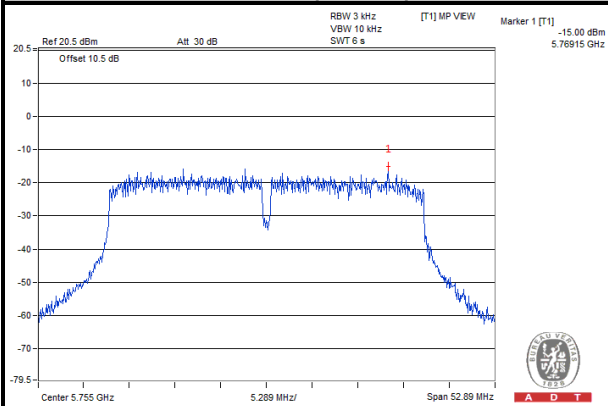

5.6 CONDUCTED OUT OF BAND EMISSION MEASUREMENT

5.6.1 LIMITS OF OUT OF BAND EMISSION MEASUREMENT

Below -20dB of the highest emission level of operating band (in 100kHz Resolution Bandwidth).

5.6.2 TEST SETUP

Same as section 4.6.2.

5.6.3 TEST INSTRUMENTS

Refer to section 4.1.2 to get information of above instrument.

5.6.4 TEST PROCEDURE

Same as section 4.6.4

5.6.5 DEVIATION FROM TEST STANDARD

No deviation.

5.6.6 EUT OPERATING CONDITION

Same as section 4.3.6

5.6.7 TEST RESULTS

The spectrum plots are attached on the following pages. D1 line indicates the highest level, and D2 line indicates the 20dB offset below D1. It shows compliance with the requirement.



A D T

802.11a

CH 149

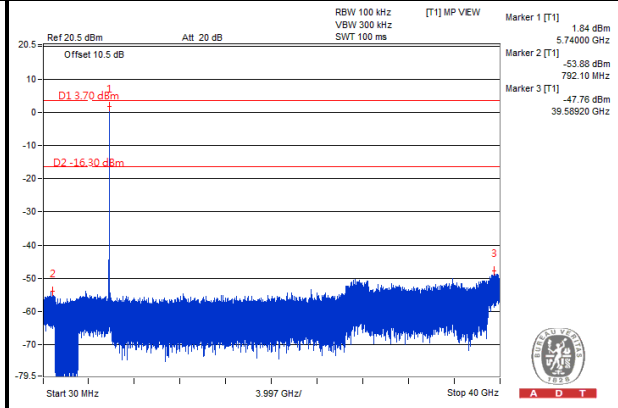
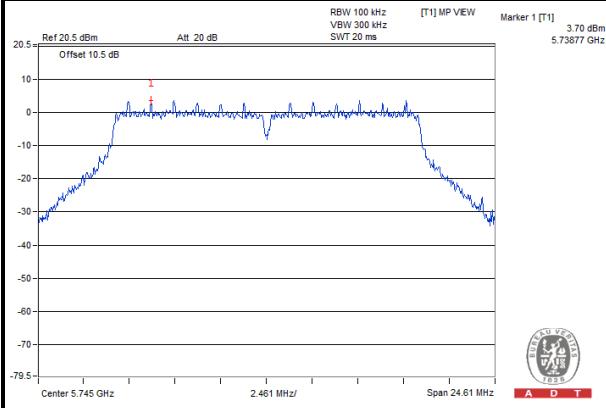

CH 157

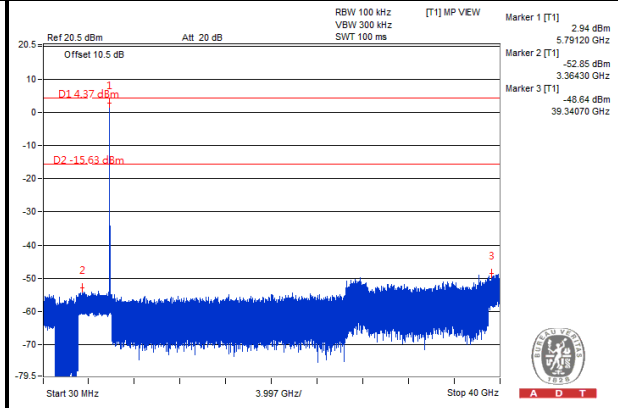
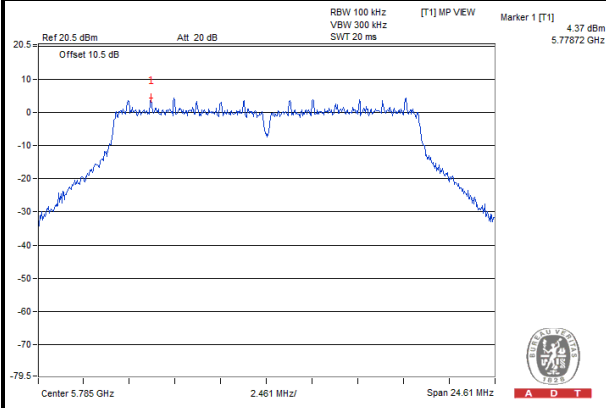

CH 161

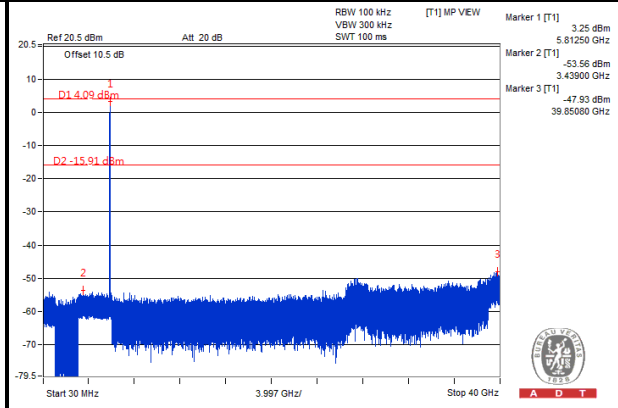
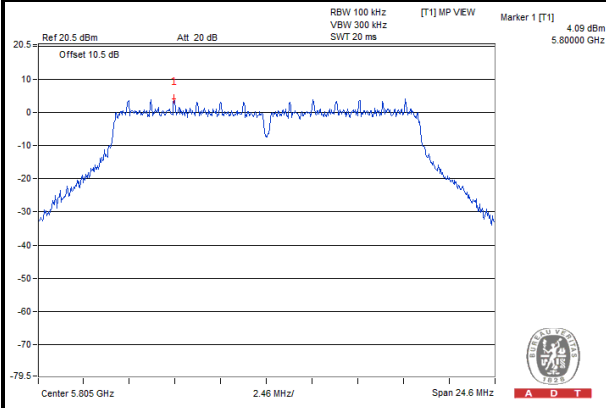



A D T

802.11n (20MHz)

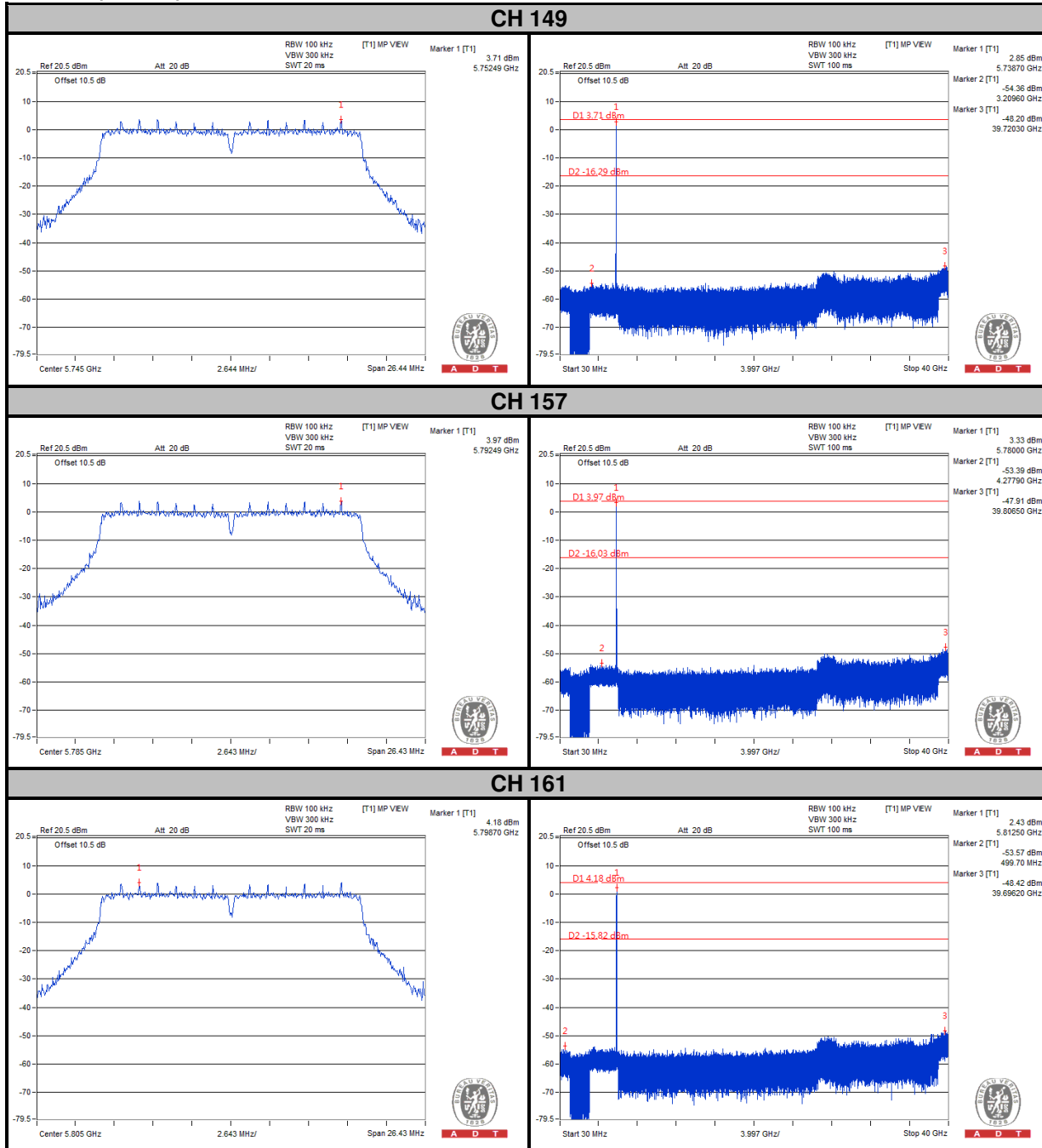



A D T

802.11n (40MHz)

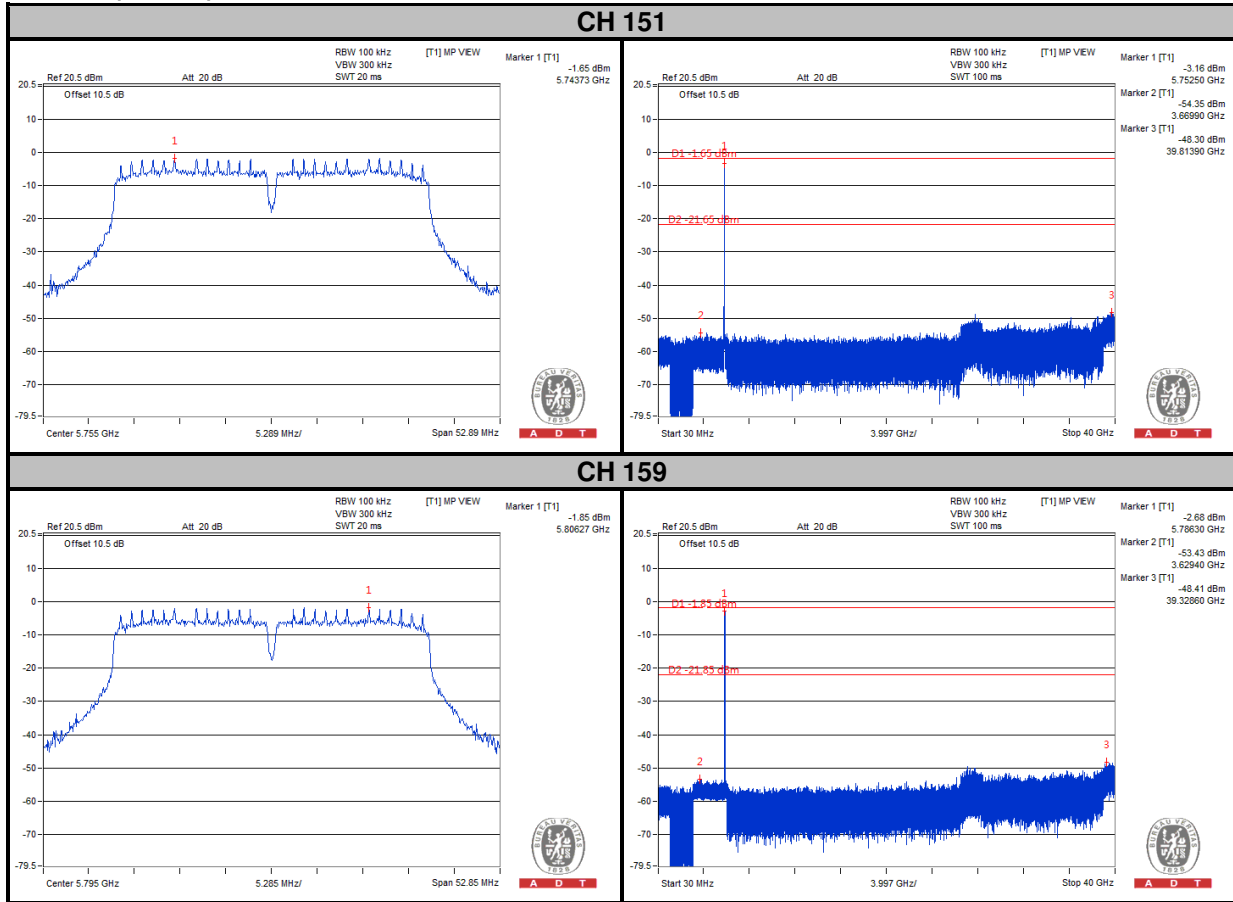



A D T

6. PHOTOGRAPHS OF THE TEST CONFIGURATION

Please refer to the attached file (Test Setup Photo).



7. INFORMATION ON THE TESTING LABORATORIES

We, Bureau Veritas Consumer Products Services (H.K.) Ltd., Taoyuan Branch, were founded in 1988 to provide our best service in EMC, Radio, Telecom and Safety consultation. Our laboratories are accredited and approved according to ISO/IEC 17025.

If you have any comments, please feel free to contact us at the following:

Linko EMC/RF Lab:

Tel: 886-2-26052180

Fax: 886-2-26051924

Hsin Chu EMC/RF Lab:

Tel: 886-3-5935343

Fax: 886-3-5935342

Hwa Ya EMC/RF/Safety Telecom Lab:

Tel: 886-3-3183232

Fax: 886-3-3270892

Email: service.adt@tw.bureauveritas.com

Web Site: www.bureauveritas-adt.com

The address and road map of all our labs can be found in our web site also.



A D T

8. APPENDIX A – MODIFICATIONS RECORDERS FOR ENGINEERING CHANGES TO THE EUT BY THE LAB

No any modifications are made to the EUT by the lab during the test.

---END---