

System Check_Head_835MHz_130710**DUT: D835V2-SN:499**

Communication System: CW; Frequency: 835 MHz; Duty Cycle: 1:1

Medium: HSL_850_130710 Medium parameters used: $f = 835$ MHz; $\sigma = 0.925$ mho/m; $\epsilon_r = 43.3$; $\rho = 1000$ kg/m³

Ambient Temperature : 23.5 °C ; Liquid Temperature : 22.5 °C

DASY4 Configuration:

- Probe: ET3DV6R - SN1788; ConvF(5.96, 5.96, 5.96); Calibrated: 2012/10/23
- Sensor-Surface: 4mm (Mechanical Surface Detection)
- Electronics: DAE3 Sn577; Calibrated: 2013/5/8
- Phantom: SAM_Left; Type: SAM; Serial: TP-1150
- Measurement SW: DASY4, V4.7 Build 80; Postprocessing SW: SEMCAD, V1.8 Build 186

Pin=250mW/Area Scan (61x61x1): Measurement grid: dx=15mm, dy=15mm

Maximum value of SAR (interpolated) = 2.62 mW/g

Pin=250mW/Zoom Scan (5x5x7)/Cube 0: Measurement grid: dx=8mm, dy=8mm, dz=5mm

Reference Value = 55.0 V/m; Power Drift = -0.006 dB

Peak SAR (extrapolated) = 3.42 W/kg

SAR(1 g) = 2.4 mW/g; SAR(10 g) = 1.59 mW/g

Maximum value of SAR (measured) = 2.59 mW/g

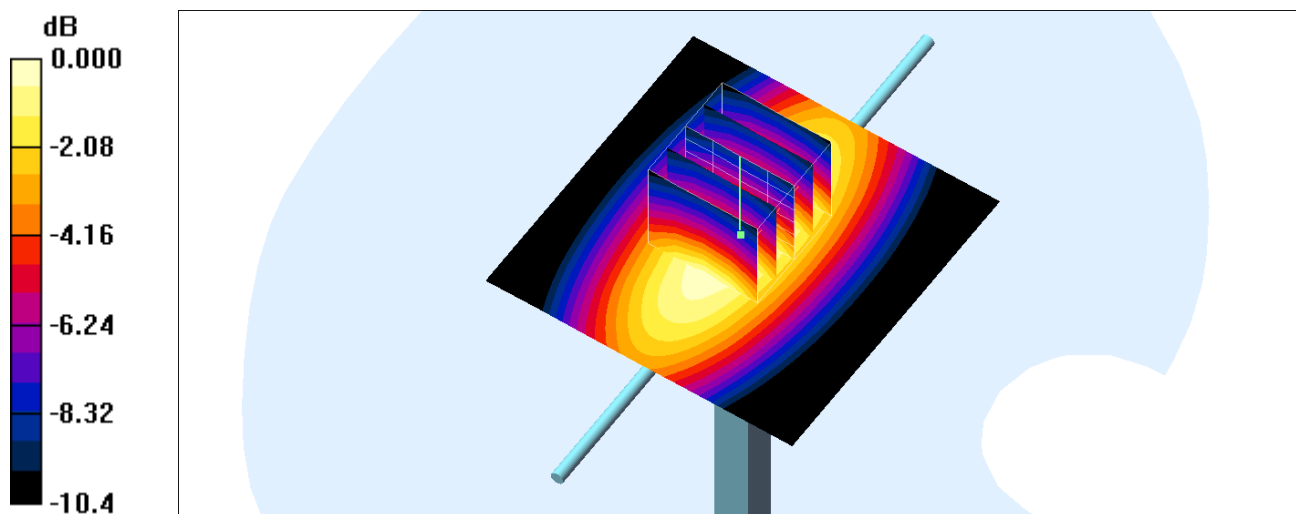

0 dB = 2.59mW/g

System Check_Body_835MHz_130709**DUT: D835V2-SN:499**

Communication System: CW; Frequency: 835 MHz; Duty Cycle: 1:1

Medium: MSL_850_130709 Medium parameters used: $f = 835$ MHz; $\sigma = 0.963$ mho/m; $\epsilon_r = 54.5$; $\rho = 1000$ kg/m³

Ambient Temperature : 23.3 °C ; Liquid Temperature : 22.3 °C

DASY4 Configuration:

- Probe: ET3DV6R - SN1788; ConvF(5.92, 5.92, 5.92); Calibrated: 2012/10/23
- Sensor-Surface: 4mm (Mechanical Surface Detection)
- Electronics: DAE3 Sn577; Calibrated: 2012/6/6
- Phantom: SAM_Right; Type: SAM; Serial: TP-1303
- Measurement SW: DASY4, V4.7 Build 80; Postprocessing SW: SEMCAD, V1.8 Build 186

Pin=250mW/Area Scan (61x61x1): Measurement grid: dx=15mm, dy=15mm

Maximum value of SAR (interpolated) = 2.76 mW/g

Pin=250mW/Zoom Scan (5x5x7)/Cube 0: Measurement grid: dx=8mm, dy=8mm, dz=5mm

Reference Value = 55.6 V/m; Power Drift = 0.019 dB

Peak SAR (extrapolated) = 3.60 W/kg

SAR(1 g) = 2.56 mW/g; SAR(10 g) = 1.7 mW/g

Maximum value of SAR (measured) = 2.76 mW/g

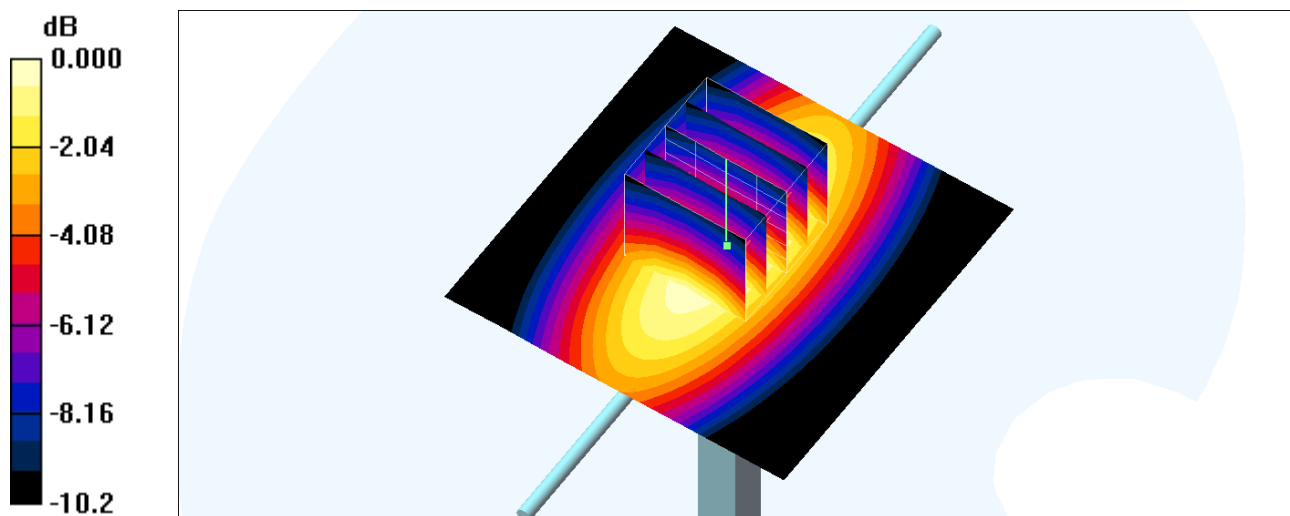

0 dB = 2.76mW/g

System Check_Body_857MHz_130802

DUT: D835V2-SN:499

Communication System: CW; Frequency: 835 MHz; Duty Cycle: 1:1

Medium: MSL_850_130802 Medium parameters used: $f = 835 \text{ MHz}$; $\sigma = 0.981 \text{ mho/m}$; $\epsilon_r = 55.337$; $\rho =$

1000 kg/m^3

Ambient Temperature : $23.5 \text{ }^\circ\text{C}$; Liquid Temperature : $22.5 \text{ }^\circ\text{C}$

DASY5 Configuration:

- Probe: EX3DV4 - SN3792; ConvF(9.15, 9.15, 9.15); Calibrated: 2013/6/4;
- Sensor-Surface: 2mm (Mechanical Surface Detection)
- Electronics: DAE4 Sn1338; Calibrated: 2013/5/28
- Phantom: SAM Left; Type: QD000P40CD; Serial: TP:1542
- Measurement SW: DASY52, Version 52.8 (3); SEMCAD X Version 14.6.5 (6469)

Configuration/Pin=250mW/Area Scan (61x61x1): Measurement grid: $dx=15\text{mm}$, $dy=15\text{mm}$
 Maximum value of SAR (interpolated) = 2.82 mW/g

Configuration/Pin=250mW/Zoom Scan (5x5x7)/Cube 0: Measurement grid: $dx=8\text{mm}$,
 $dy=8\text{mm}$, $dz=5\text{mm}$

Reference Value = 54.511 V/m ; Power Drift = 0.14 dB

Peak SAR (extrapolated) = 3.528 mW/g

SAR(1 g) = 2.34 mW/g ; SAR(10 g) = 1.51 mW/g

Maximum value of SAR (measured) = 2.98 mW/g

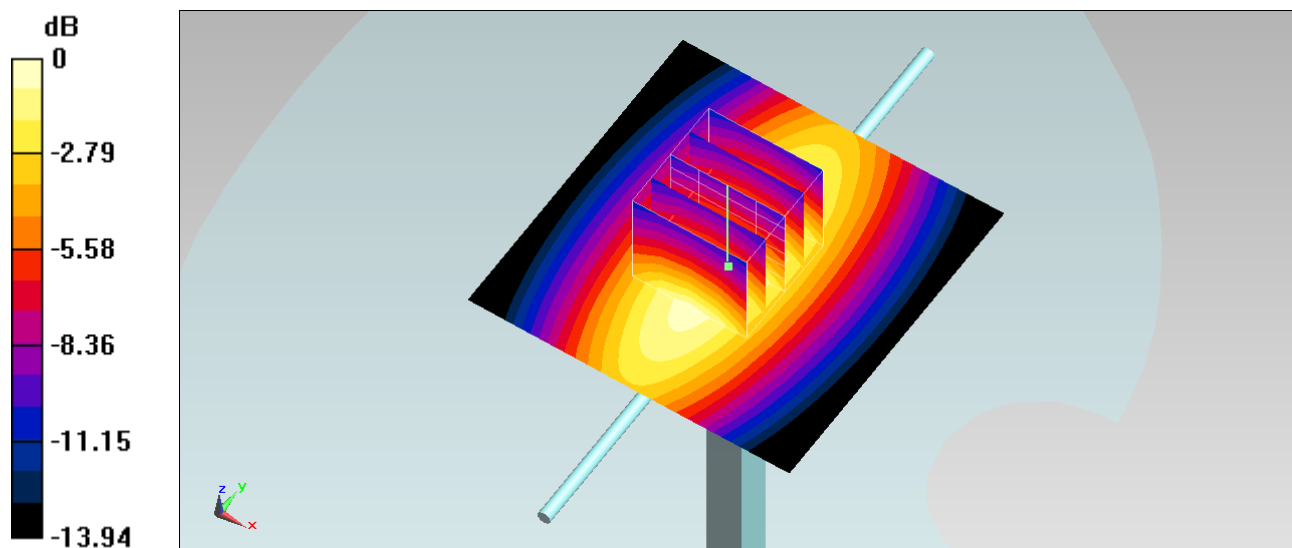

$0 \text{ dB} = 2.98 \text{ mW/g} = 9.48 \text{ dB mW/g}$

System Check_Head_1900MHz_130710

DUT: D1900V2-SN:5d041

Communication System: CW; Frequency: 1900 MHz; Duty Cycle: 1:1

Medium: HSL_1900_130710 Medium parameters used: $f = 1900$ MHz; $\sigma = 1.45$ mho/m; $\epsilon_r = 38.3$; $\rho = 1000$ kg/m³

Ambient Temperature : 2 .5 °C ; Liquid Temperature : 2 .5 °C

DASY4 Configuration:

- Probe: ET3DV6R - SN1788; ConvF(4.65, 4.65, 4.65); Calibrated: 2012/10/23
- Sensor-Surface: 4mm (Mechanical Surface Detection)
- Electronics: DAE3 Sn577; Calibrated: 2013/5/8
- Phantom: SAM_Right; Type: SAM; Serial: TP-1303
- Measurement SW: DASY4, V4.7 Build 80; Postprocessing SW: SEMCAD, V1.8 Build 186

Pin=250mW/Area Scan (61x61x1): Measurement grid: dx=15mm, dy=15mm

Maximum value of SAR (interpolated) = 11.8 mW/g

Pin=250mW/Zoom Scan (5x5x7)/Cube 0: Measurement grid: dx=8mm, dy=8mm, dz=5mm

Reference Value = 92.6 V/m; Power Drift = 0.013 dB

Peak SAR (extrapolated) = 16.4 W/kg

SAR(1 g) = 9.74 mW/g; SAR(10 g) = 5.19 mW/g

Maximum value of SAR (measured) = 10.7 mW/g

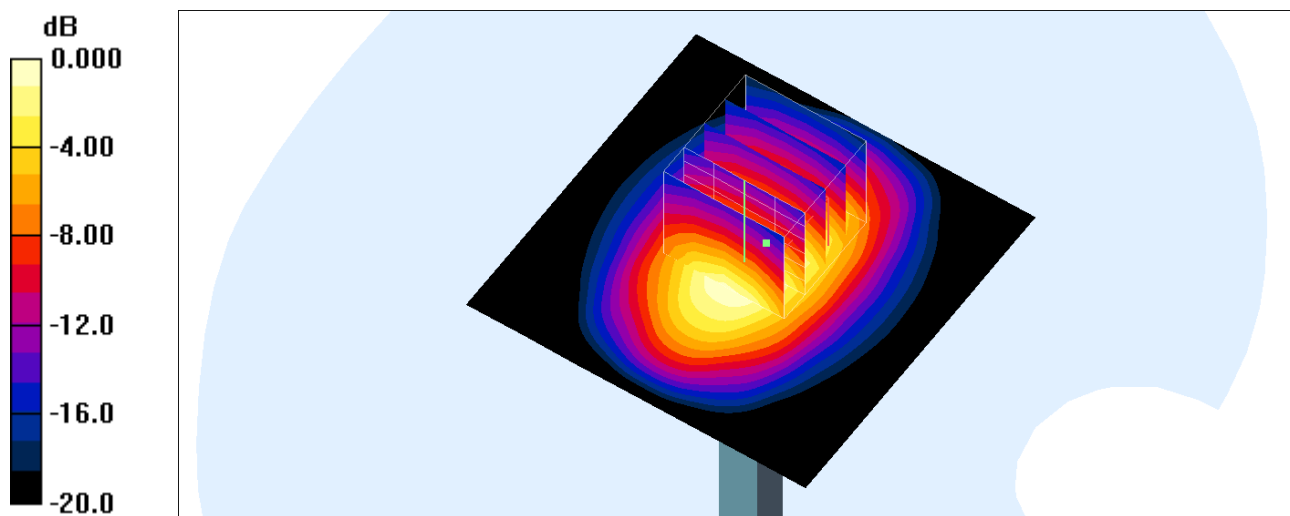

0 dB = 10.7mW/g

System Check_Body_1900MHz_130709

DUT: D1900V2-SN:5d041

Communication System: CW; Frequency: 1900 MHz; Duty Cycle: 1:1

Medium: MSL_1900_130709 Medium parameters used: $f = 1900$ MHz; $\sigma = 1.53$ mho/m; $\epsilon_r = 52.7$; $\rho = 1000$ kg/m³

Ambient Temperature : 25 °C; Liquid Temperature : 25.5 °C

DASY4 Configuration:

- Probe: ET3DV6R - SN1788; ConvF(4.15, 4.15, 4.15); Calibrated: 2012/10/23
- Sensor-Surface: 4mm (Mechanical Surface Detection)
- Electronics: DAE3 Sn577; Calibrated: 2013/5/8
- Phantom: SAM_Right; Type: SAM; Serial: TP-1303
- Measurement SW: DASY4, V4.7 Build 80; Postprocessing SW: SEMCAD, V1.8 Build 186

Pin=250mW/Area Scan (61x61x1): Measurement grid: dx=15mm, dy=15mm

Maximum value of SAR (interpolated) = 11.8 mW/g

Pin=250mW/Zoom Scan (5x5x7)/Cube 0: Measurement grid: dx=8mm, dy=8mm, dz=5mm

Reference Value = 91.5 V/m; Power Drift = 0.024 dB

Peak SAR (extrapolated) = 15.8 W/kg

SAR(1 g) = 9.75 mW/g; SAR(10 g) = 5.21 mW/g

Maximum value of SAR (measured) = 11.0 mW/g

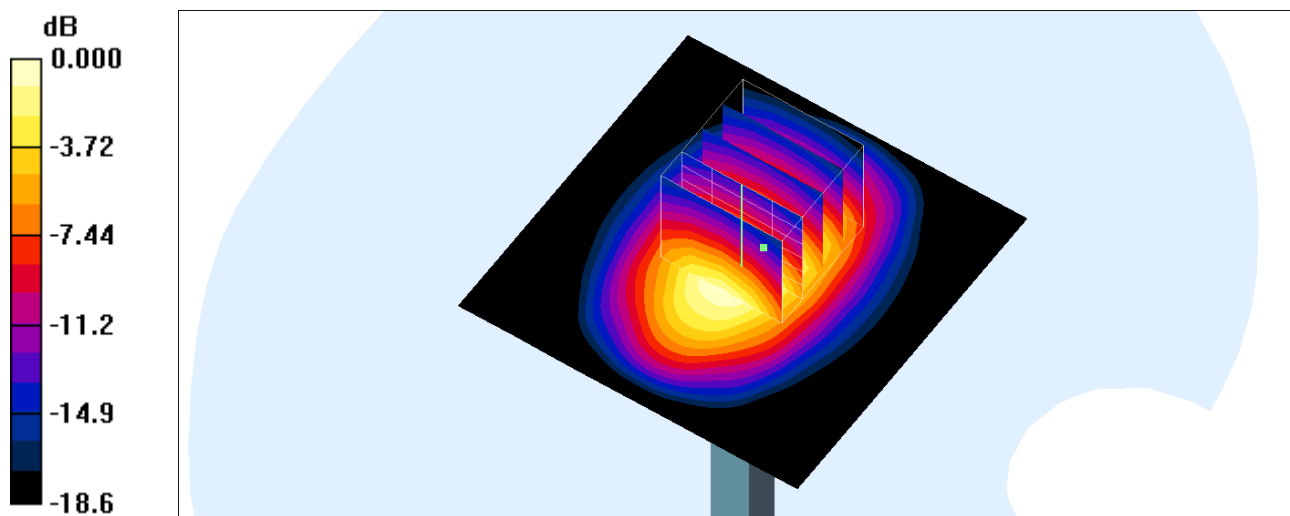

0 dB = 11.0mW/g

System Check_Body_1900MHz_130803

DUT: D1900V2-SN:5d041

Communication System: CW; Frequency: 1900 MHz; Duty Cycle: 1:1

Medium: MSL_1900_130803 Medium parameters used: $f = 1900 \text{ MHz}$; $\sigma = 1.532 \text{ mho/m}$; $\epsilon_r = 52.328$; ρ

$= 1000 \text{ kg/m}^3$

Ambient Temperature : $23.4 \text{ }^\circ\text{C}$; Liquid Temperature : $22.4 \text{ }^\circ\text{C}$

DASY5 Configuration:

- Probe: EX3DV4 - SN3925; ConvF(7.91, 7.91, 7.91); Calibrated: 2013/6/12;
- Sensor-Surface: 2mm (Mechanical Surface Detection)
- Electronics: DAE3 Sn495; Calibrated: 2013/5/8
- Phantom: SAM Left; Type: QD000P40CD; Serial: TP:1542
- Measurement SW: DASY52, Version 52.8 (3); SEMCAD X Version 14.6.5 (6469)

Configuration/Pin=250mW/Area Scan (91x91x1): Measurement grid: $dx=10\text{mm}$, $dy=10\text{mm}$
 Maximum value of SAR (interpolated) = 10.9 mW/g

Configuration/Pin=250mW/Zoom Scan (7x7x7)/Cube 0: Measurement grid: $dx=5\text{mm}$,
 $dy=5\text{mm}$, $dz=5\text{mm}$

Reference Value = 81.972 V/m ; Power Drift = 0.12 dB

Peak SAR (extrapolated) = 18.135 mW/g

SAR(1 g) = 9.88 mW/g ; SAR(10 g) = 5.47 mW/g

Maximum value of SAR (measured) = 10.9 mW/g

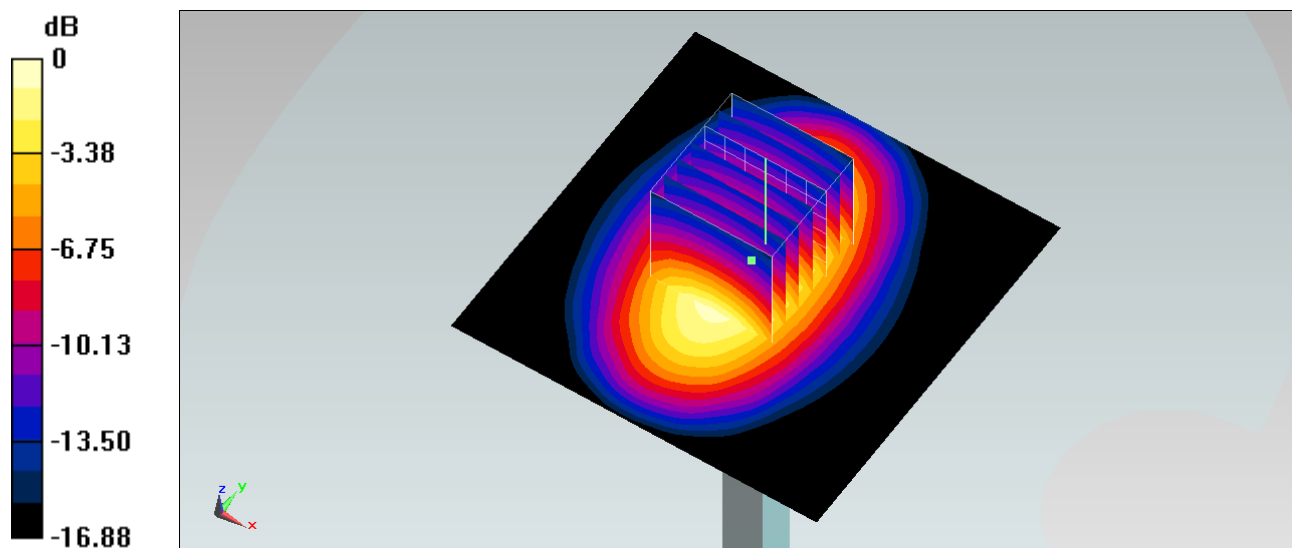

0 dB = $10.9 \text{ mW/g} = 20.75 \text{ dB mW/g}$

System Check_Head_2450MHz_130711

DUT: D2450V2-SN:869

Communication System: CW; Frequency: 2450 MHz; Duty Cycle: 1:1

Medium: HSL_2450_130711 Medium parameters used: $f = 2450$ MHz; $\sigma = 1.856$ mho/m; $\epsilon_r = 39.22$; $\rho =$

1000 kg/m³

Ambient Temperature : 23.5 °C ; Liquid Temperature : 22.5 °C

DASY5 Configuration:

- Probe: ES3DV3 - SN3270; ConvF(4.45, 4.45, 4.45); Calibrated: 2012/9/28;
- Sensor-Surface: 3mm (Mechanical Surface Detection)
- Electronics: DAE4 Sn778; Calibrated: 2012/8/27
- Phantom: SAM Left; Type: QD000P40CD; Serial: TP:1542
- Measurement SW: DASY52, Version 52.8 (3); SEMCAD X Version 14.6.5 (6469)

Configuration/Pin=250mW/Area Scan (61x61x1): Measurement grid: dx=12mm, dy=12mm
Maximum value of SAR (interpolated) = 19.4 mW/g

Configuration/Pin=250mW/Zoom Scan (7x7x7)/Cube 0: Measurement grid: dx=5mm, dy=5mm, dz=5mm

Reference Value = 105.0 V/m; Power Drift = -0.08 dB

Peak SAR (extrapolated) = 29.701 mW/g

SAR(1 g) = 14.2 mW/g; SAR(10 g) = 6.47 mW/g

Maximum value of SAR (measured) = 18.6 mW/g

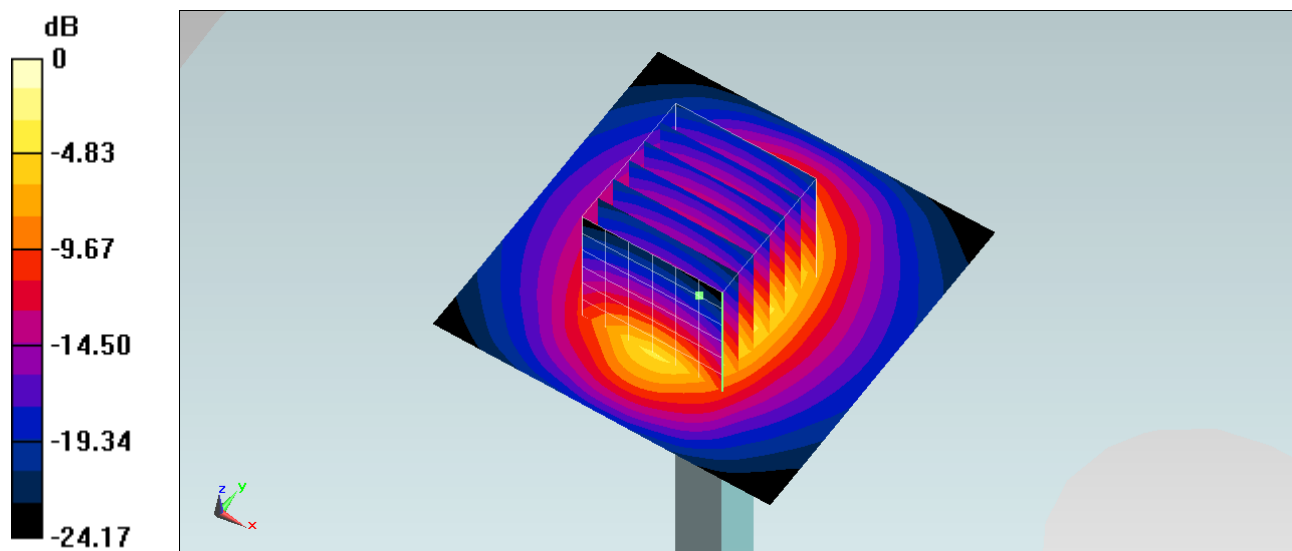

System Check_Body_2450MHz_130711

DUT: D2450V2-SN:869

Communication System: CW; Frequency: 2450 MHz; Duty Cycle: 1:1

Medium: MSL_2450_130711 Medium parameters used: $f = 2450$ MHz; $\sigma = 2.02$ mho/m; $\epsilon_r = 53.886$; $\rho =$

1000 kg/m³

Ambient Temperature : 23.4 °C ; Liquid Temperature : 22.4 °C

DASY5 Configuration:

- Probe: EX3DV4 - SN3925; ConvF(7.44, 7.44, 7.44); Calibrated: 2013/6/12;
- Sensor-Surface: 2mm (Mechanical Surface Detection)
- Electronics: DAE3 Sn495; Calibrated: 2013/5/8
- Phantom: SAM Right; Type: QD000P40CC; Serial: TP:1383
- Measurement SW: DASY52, Version 52.8 (3); SEMCAD X Version 14.6.5 (6469)

Configuration/Pin=250mW/Area Scan (61x61x1): Measurement grid: dx=12mm, dy=12mm
Maximum value of SAR (interpolated) = 22.0 mW/g

Configuration/Pin=250mW/Zoom Scan (7x7x7)/Cube 0: Measurement grid: dx=5mm, dy=5mm, dz=5mm

Reference Value = 99.214 V/m; Power Drift = -0.01 dB

Peak SAR (extrapolated) = 28.733 mW/g

SAR(1 g) = 13.1 mW/g; SAR(10 g) = 6.04 mW/g

Maximum value of SAR (measured) = 20.2 mW/g

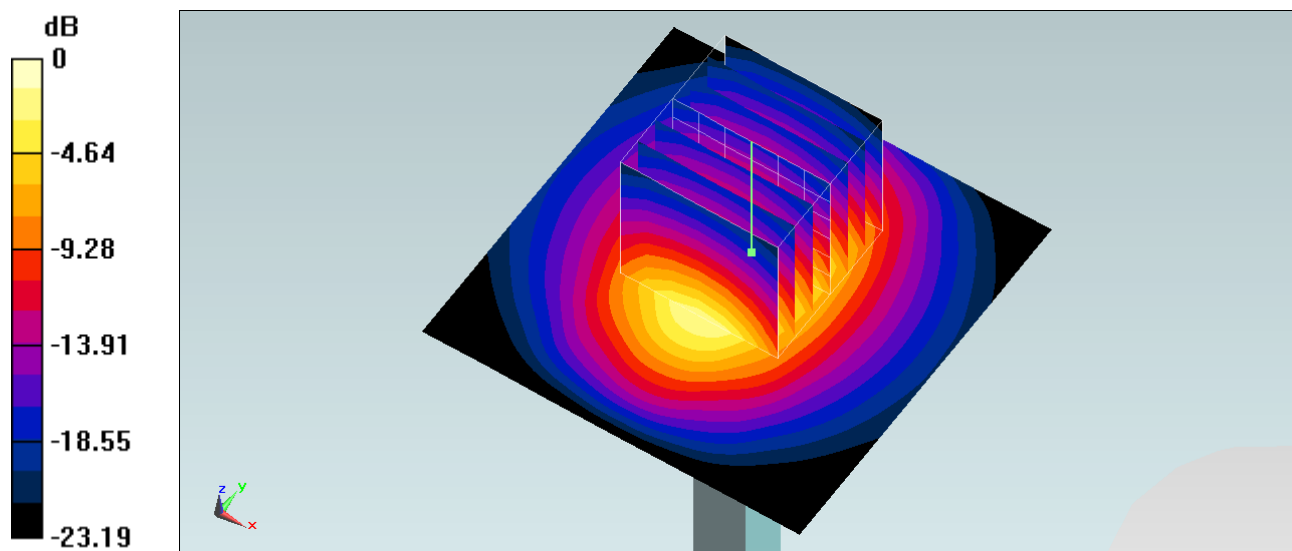

0 dB = 20.2 mW/g = 26.11 dB mW/g