



PRODUCT NAME: AIRONET LM4511 RADIO

NAME OF TEST: The Processing Gain of a Direct Sequence System.

FCC Part 15.247 (e) specifies:

The processing gain of a direct sequence system shall be at least 10 dB.

Guidance on measurement by FCC

The processing gain may be measured using the CW jamming margin method. The test consists of stepping a signal generator in 50kHz increments across the passband of the system. At each point, the generator level required to produce the recommended Bit Error Rate (10<sup>-5</sup>) is recorded. This is the jammer level. The output power of the transmitting unit is measured at the same point. The Jammer to Signal (J/S) ratio is then calculated. Discard the worst 20% of the J/S data points. Total losses in a system including transmitter and receiver, should be assumed to be no more than 2 dB.

therefore, processing gain = S/N + Mj + Lsys

Where :

S/N = Signal to noise ratio required at the receiver output for 10<sup>-5</sup> error rate of a ideal receiver for your demodulation scheme

Mj = Jammer to signal ratio

Lsys = System losses (2dB max)

Test results :

for 1 mb data rate:

S/N = 13 dB ; taken from Wireless Information Networks by Pahlavan & Levesque

Mj = - 0.6 dB ; worst case jamming margin from tests in lab

Lsys = 0.5 dB ; system losses

**therefore the processing gain at 1mb is 13 dB - 0.6 dB + 0.5 dB = 12.9 dB**

for 2 mb data rate:

S/N = 13 dB ; taken from Wireless Information Networks by Pahlavan & Levesque

Mj = - 3.3 dB ; worst case jamming margin from tests in lab

Lsys = 2.0 dB ; system losses

**therefore the processing gain at 2mb is 13 dB - 3.3 dB + 2.0 dB = 11.7 dB**

### Jamming Test Setup

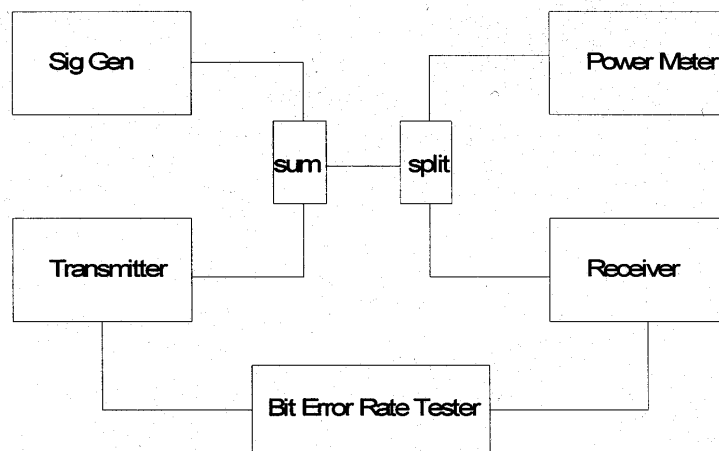

<b>AIRONET</b> RF Systems Engineering	
2.4 GHz SPREAD SPECTRUM RADIO, 2nd GEN	
Jammer Test, R240	
eng: J. Friedmann dvg: J. Friedmann	File: FCC025_2.dwg Date: 3/21/96 rev: