

System Design Specification

Project: SEW-3037WN Wireless Baby Monitor

REVISION NOTE

NO	Revision	Date	Description	Draft
1	1.0	2012-05-22	System Design Specification	Lawrence
2	2.0	2012-07-11	Review the engineering specification	Lawrence
3				
4				
5				
6				
7				

Date	
Charger	
Department	

THE INFORMATION CONTAINED IN THIS DOCUMENT IS PROPRIETARY TO GCT AND SHALL NOT BE REPRODUCED OR USED IN PART OR WHOLE WITHOUT GCT'S WRITTEN CONSENT. ALL RIGHTS RESERVED.

Table of Contents	Page
1. Overview.....	3
1.1 Purpose.....	3
1.2 Structure.....	3
1.3 Document chapter.....	3
2. Wireless monitor overview.....	3
3. Wireless monitor system introduction.....	3
3.1 Conditions are considered during development.....	3
3.1.1 Environment conditions.....	3
3.1.1.1 Operation conditions.....	3
3.1.1.2 Transportation conditions.....	3
3.1.1.3 Storage conditions.....	3
3.1.2 Safety & EMC certificate.....	4
3.2 Wireless baby monitor system structure.....	4
3.2.1 Layout.....	4, 5
3.2.2 Block diagram.....	6, 7
3.2.3 Power supply.....	7
4. System interface.....	8
5. Hardware requirement.....	8
6. Software requirement.....	8
7. Engineering specification.....	9
Appendix A:	10

TITLE:SEW-3037W System Design Specification

1. Overview

1.1 Purpose

This document is subject to explain wireless baby monitor design specification and will be used for develop and verify the function of product.

1.2 Structure

Wireless baby monitor include two sections as below.

Parent unit: Receive video and audio signal that picked up baby unit and output at the speaker. It charges up the Li Ion battery and indicates loudness with sound bar.

Baby unit: Capture video and audio signal from the environment and transit to the parent unit through RF.

1.3 Document chapter

Chapter 2 Wireless baby monitor overview:	Explain the wireless baby monitor
Chapter 3 Wireless baby monitor description:	Explain the structure of the system
Chapter 4 System Interface:	Define the specification of interface
Chapter 5 H/W requirement:	Define feature list
Chapter 6 S/W requirement:	Define S/W requirement
Chapter 7 Engineering specification:	Define H/W parameter specification

2. Wireless baby monitor overview

Having a baby will entail you to sacrifice a lot of things. This could include work, a hobby, and even your normal way of living. But, you do not have to sacrifice that much anymore. If you are thinking that this is about nanny services, then you are wrong. This is really about a device named wireless baby monitor which helps you keep a close monitor on the activities and the status of your baby. In fact, you can even hear him sound even as you are both not in the same room.

The wireless baby monitor, on the other hand, gives you the advantage of traveling even outside your home for as long as the reception is reachable. This will give you unlimited access within your home. Just make sure to check with the manufacturer the maximum distance that the coverage can reach.

3. Wireless baby monitor description

3.1 Conditions are considered during development.

3.1.1 Environment conditions

3.1.1.1 Operation conditions

Temperature:-10~40 Celsius

Humidity: <85%

3.1.1.2 Transportation conditions

Temperature:-20~50 Celsius

Humidity: <90%

3.1.1.3 Storage conditions

Temperature:-20~50 Celsius

Humidity: <90%

TITLE:SEW-3037W System Design Specification

3.1.2 Safety &EMC Certificate

EU version	EN300 328 EN301 489 EN60950
FCC version	FCC Part 15

3.2 Wireless baby monitor system structure.

3.2.1 Layout

Baby unit layout



Parent unit layout

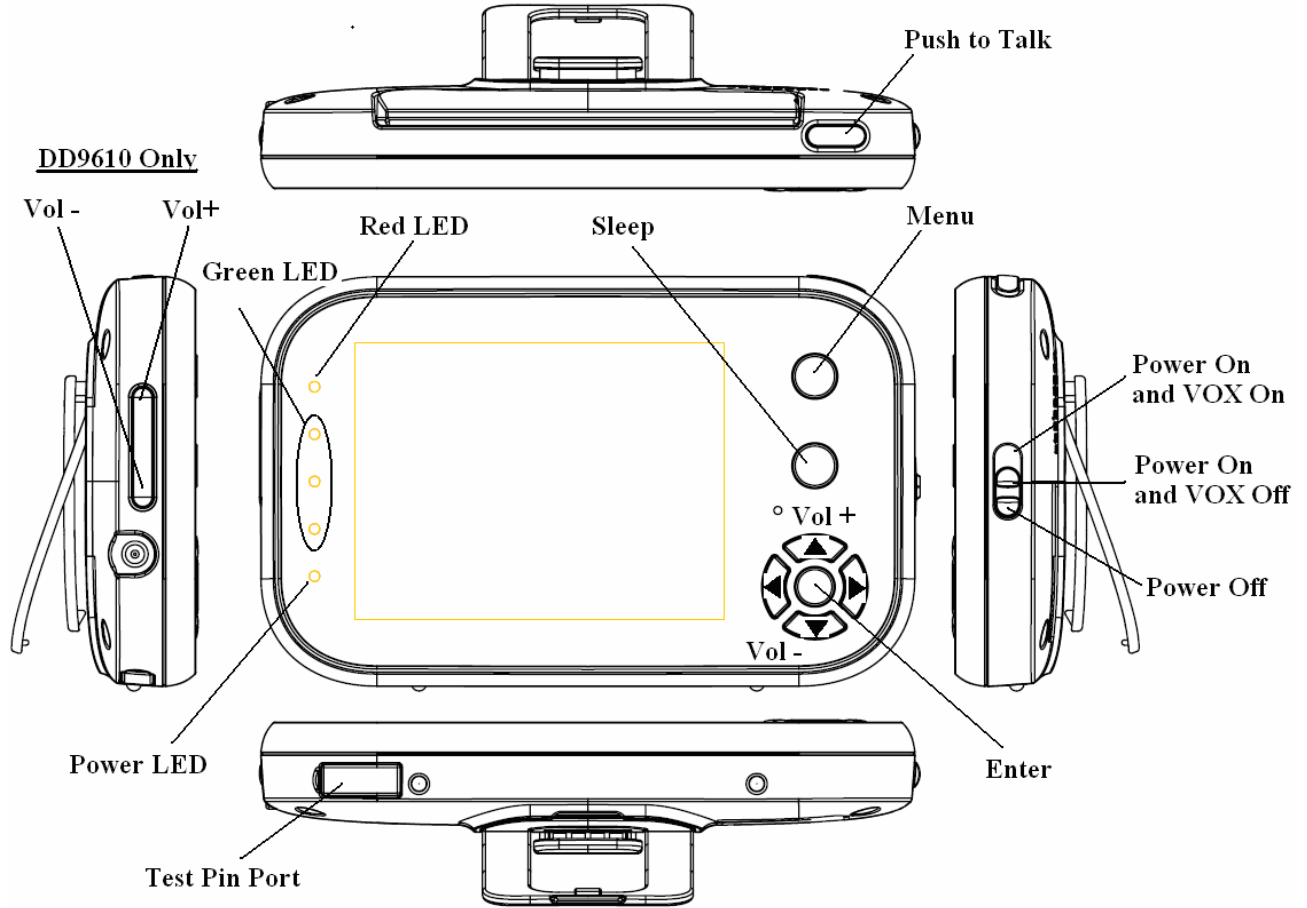

3.2.2 Block Diagram

Baby unit block diagram

SEW-3037W Video Baby Monitor Baby unit block diagram

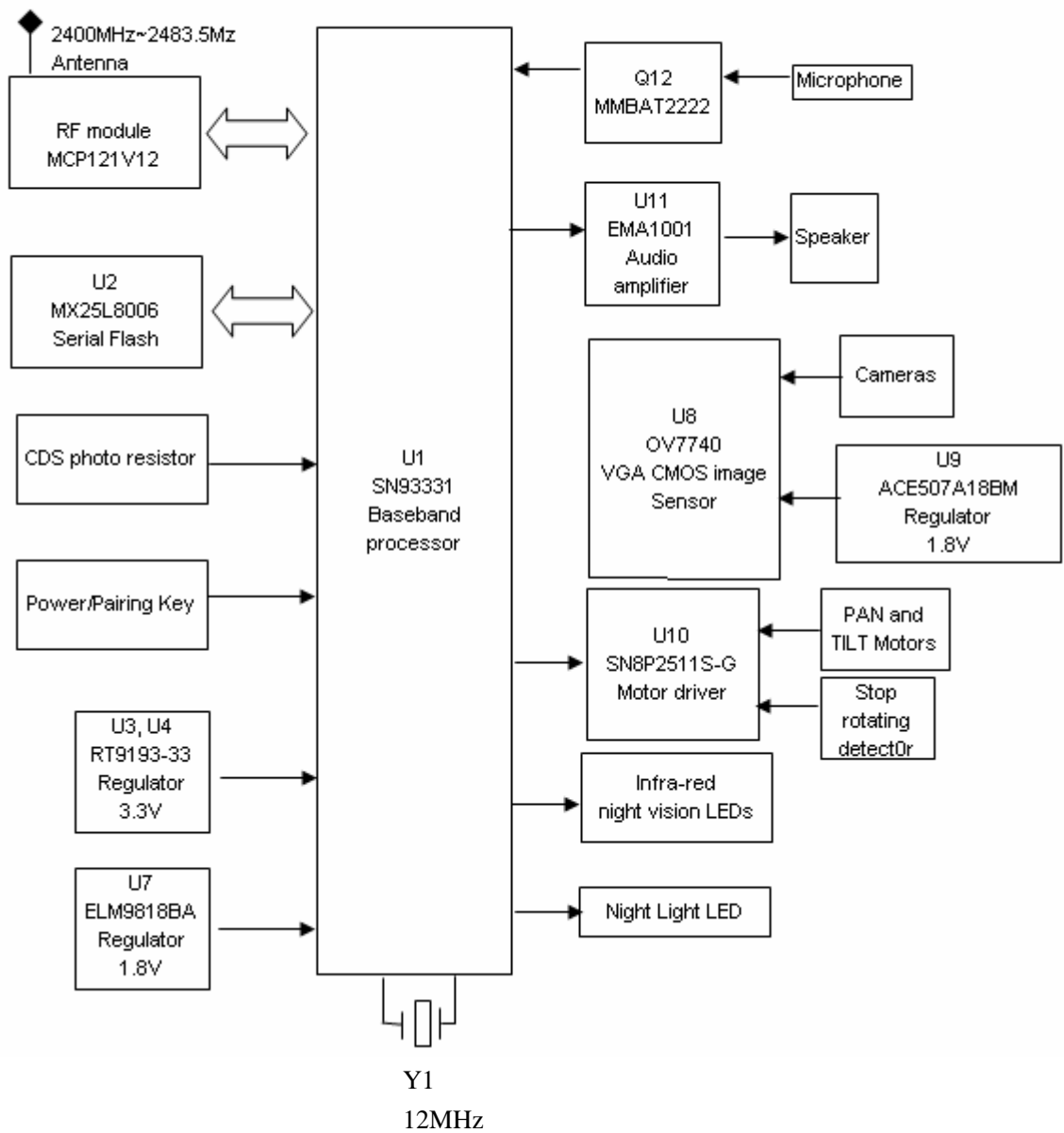

Parent unit block diagram

SEW-3037W Video Baby Monitor Parent unit block diagram

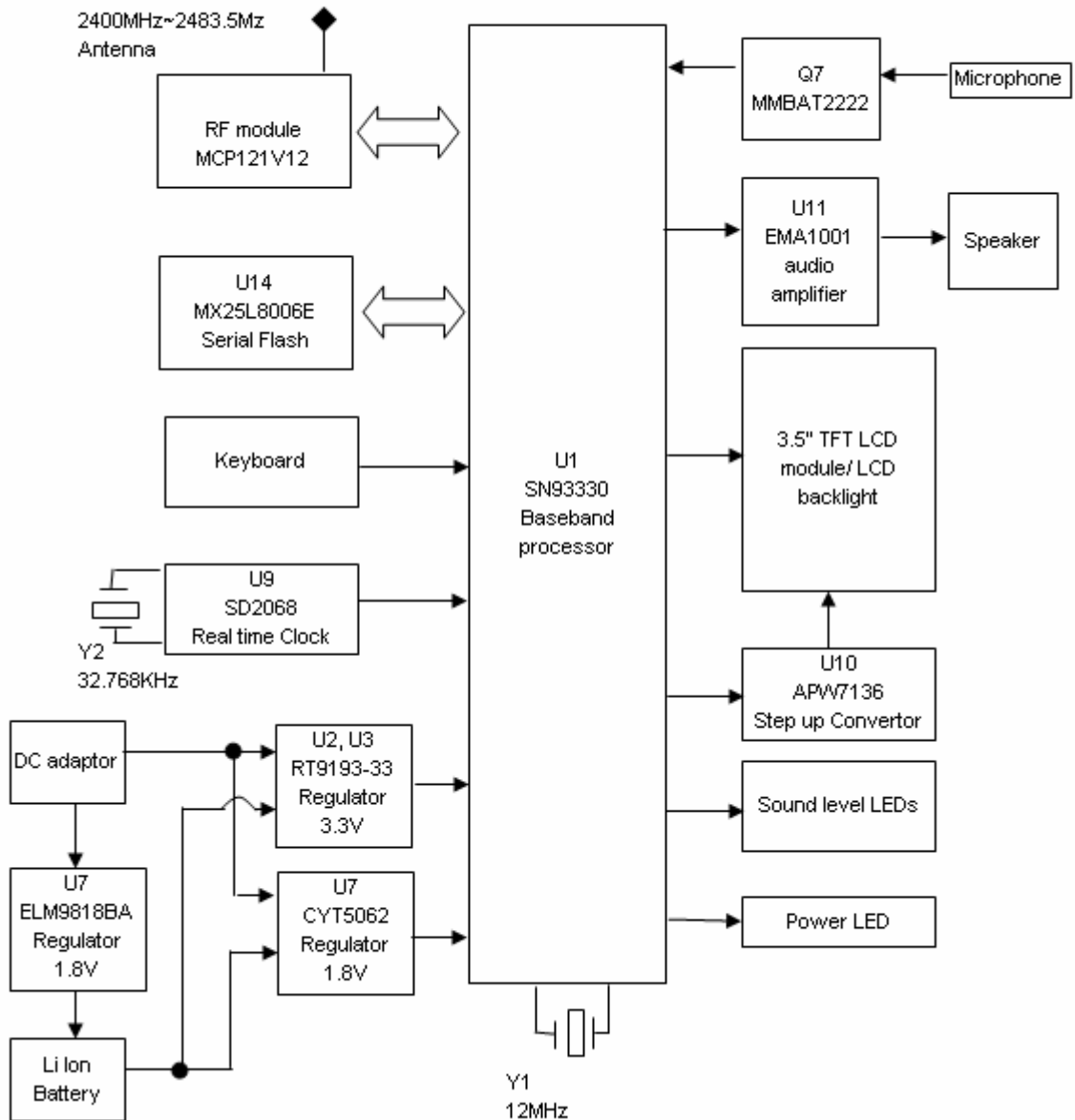

3.2.3 Power supply

6V 800mA Power adaptor uses for both baby and parent units. It complies with CE (EU version) or FCC and TUS/UL (US version) standard.

4. System Interface

Audio sound triggers VOX level at the baby unit side.

VOX level: High: 50dBA/Low: 60dBA at baby microphone section

5. Hardware Requirement

Feature list

Technology

Digital Wireless technology features the latest advancements in wireless video monitor system

Minimize interference with other devices such as wireless routers, cordless phones, and Bluetooth devices. It is Wi-Fi friendly.

100% Digital video and audio provides excellent image quality and crystal clear sound.

Offers a secure connection between the receiver and camera for total privacy

Signal strength and out of range notifications help you find the best possible installation location

Parent unit

3.5" Color LCD monitor with built-in wireless receiver

One preloaded scenery images enable digital picture frame simulation when no sound trigger is detected by the cameras

Low battery indicator and alert

Real time clock

System expandable up to 4 cameras

Place on the tabletop or wall/ under counter mount with included accessories

Viewing Options:

Auto Sequence Mode displays all cameras in Full Screen

Single Channel Full Screen viewing

Screen Saver mode with Sound Activated Single Channel Full Screen Viewing

Intercom function allows for 2 way communication between Parent and Baby units. Speak to the person at the baby unit side.

On-screen menu system makes set-up and changing setting easy

System expandable up to 4 cameras

Baby unit

VGA (640X480) Resolution Camera

IR Night Vision

Sound Trigger

Built-in microphone and speaker for listening and speaking

6. Software Requirement

Please refer to SRS files

7. Engineering Specification

System General	
Operating Frequency Range	2400 MHz~2483.5 MHz
Transmitting Power	17dBm Max
Receiver Sensitivity	-88dBm
Type of Spread Spectrum TX	FHSS
Type of Modulation	GFSK
Data Rate	3Mbps
Transmission range	Outdoor 300 m (Eye of Sight)
Baby unit	
Image Sensor Type	1/5" Color CMOS Image Sensor
Effective Pixel	H 640 V480
White Balance	Auto
Lens	EFL=3.6mm F=2.8
Viewing Angle (Diagonal)	56 degree
IR LED Type/ Night Vision	8pcs IR LED – 940nm
Loud Speaker Output	78dBA
Power Requirement	6V +/-10%
Power Consumption	480mA Condition Night vision mode , motor in motion and talk back
VOX level detection	High:55dBA/Low:65dBA
Operating Temperature Range	-10~40 degree C
Operating Humidity Range	85% RH
Environment Rating	Indoor use only
Regulation Compliance	FCC/CE
RoHS Compliance	Yes for CE version only
Other Special Feature	Built in Microphone/ Speaker
Parent unit	
Display Type/Size	Color TFT 3.5"
Resolution (Pixel)	320X240 (RGB)
Viewing Angle	H 80 degree V 100 degree
Number of Camera Support	Up to 4 baby units
Power Requirement	Adaptor 6 +/-10% Battery 3.7V Li Ion battery
Loud Speaker Output	78dBA
Power Consumption	480mA maximum Condition Charging + Speaker with voice at volume 5
Operating Temperature Range	-10~40degree C
Operating Humidity Range	85% RH
Environment Rating	Indoor use only
Regulation Compliance	FCC/CE
RoHS Compliance	Yes for CE version only
Other Special Feature	Volume control, Pairing

Appendix A

The Digital Wireless signal transmission type used by the SEW-306W, SEW-3037W is also known as FHSS –Frequency Hopping Spread Spectrum. This type of signal is highly resistant to deliberate jamming as it generates a channel hopping sequence using an algorithm generated by the receiver system.

The 2.4GHz (2.400-2.483.5Ghz) band is being divided into sections or paths, and each second the transmission signal hops hundreds of times in a specified sequence within this frequency range. The overall bandwidth required for frequency hopping is much wider than 2MHz however because transmission occurs only on a small section of this bandwidth at any given time, the signal being transmitted does not suffer from greatly reduced signal degradation and also avoids blocked paths other devices who act as sources of competing signals. The strength of the signal being transmitted is set to be from 17dBm (max), which is much higher than the analog transmission signal allowed by authorities around the world.

When an image is captured by the camera it is instantly converted from an analog to digital signal and packaged into small packets. With each successful transmission via the 3 MHz paths discussed above, the packets of information containing images are delivered to the receiver and decoded into analog information. The information can then be displayed on devices that are connected to the wireless receiver (Rx).

A device pairing process is required to synchronize the transmitter (Tx, Baby) and the receiver (RX, Parent). This allows the transmitter and receiver to be on the same frequency and use the same algorithm for frequency hopping. This ensures that only the paired transmitter and receiver can maintain communication signal by hopping to the same frequency paths at the exact same time. As a result, the chance that other devices within the same frequency range are on the same frequency, at the same time and in the same order is extremely unlikely.

Note that the pairing process is already done at the factory for products that ship within the same packaging. Only when add-on devices are purchased is a pairing process required

---End of Document---