



Shenzhen General Testing & Inspection Technology Co.,Ltd.

1-2/F., Building 2, Jiaquan Building, Guanlan High-Tech Park, Shenzhen, Guangdong, China
Tel: +86-755- 27521059 Fax: +86-755- 27521011 Http://www.sz-ctc.com.cn

TEST REPORT

Report No.: **GTI20181998F**

FCC ID.....: **NKS-S597**

Applicant.....: **PeopleNet Communications Corporation**

Address.....: 4400 Baker Road, Minnetonka, Minnesota, United States

Manufacturer.....: STONKAM CO.,LTD.

Address.....: 5/F., #3 Building, Huangzhou Industrial Park, Chebei Rd., Tianhe Dist., 510665 Guangzhou, China

Product Name.....: **DVR S597**

Trade Mark.....: N/A

Model/Type reference.....: E-006-0597

Listed Model(s): N/A

Standard.....: **FCC CFR Title 47 Part 2**
FCC CFR Title 47 Part 22
FCC CFR Title 47 Part 24
FCC CFR Title 47 Part 27

Date of receipt of test sample...: 2018-10-23

Date of testing.....: 2018-10-24 to 2018-11-24

Date of issue.....: 2018-11-25

Result.....: **PASS**

Compiled by:
(Printed name+signature) Terry Su

Supervised by:
(Printed name+signature) Cary Luo

Approved by:
(Printed name+signature) Walter Chen

Testing Laboratory Name..... **Shenzhen General Testing & Inspection Technology Co.,Ltd.**

Address..... 1-2/F., Building 2, Jiaquan Building, Guanlan High-Tech Park,
Shenzhen, Guangdong, China

This test report may be duplicated completely for legal use with the approval of the applicant. It should not be reproduced except in full, without the written approval of our laboratory. The client should not use it to claim product endorsement by GTI. The test results in the report only apply to the tested sample. The test report shall be invalid without all the signatures of testing engineers, reviewer and approver. Any objections must be raised to GTI within 15 days since the date when the report is received. It will not be taken into consideration beyond this limit. The test report merely correspond to the test sample.



Table of Contents

Page

- 1. SUMMARY.....3
 - 1.1. TEST STANDARDS.....3
 - 1.2. REPORT VERSION.....3
 - 1.3. TEST DESCRIPTION.....4
 - 1.4. TEST FACILITY5
 - 1.5. MEASUREMENT UNCERTAINTY5
 - 1.6. ENVIRONMENTAL CONDITIONS6
- 2. GENERAL INFORMATION7
 - 2.1. CLIENT INFORMATION7
 - 2.2. GENERAL DESCRIPTION OF EUT7
 - 2.3. DESCRIPTION OF TEST MODES AND TEST FREQUENCY.....8
 - 2.4. MEASUREMENT INSTRUMENTS LIST10
- 3. TEST ITEM AND RESULTS11
 - 3.1. CONDUCTED OUTPUT POWER11
 - 3.2. PEAK-TO-AVERAGE RATIO12
 - 3.3. OCCUPY BANDWIDTH.....13
 - 3.4. OUT OF BAND EMISSION AT ANTENNA TERMINALS.....14
 - 3.5. BAND EDGE COMPLIANCE15
 - 3.6. RADIATED POWER MEASUREMENT16
 - 3.7. RADIATED SPURIOUS EMISSION.....26
 - 3.8. FREQUENCY STABILITY38
- 4. EUT TEST PHOTOS53
- 5. PHOTOGRAPHS OF EUT CONSTRUCTIONAL54



1. SUMMARY

1.1. Test Standards

The tests were performed according to following standards:

[FCC Rules Part 2:](#) FREQUENCY ALLOCA-TIONS AND RADIO TREATY MAT-TERS; GENERAL RULES AND REG-ULATIONS

[FCC Rules Part 22:](#) PRIVATE LAND MOBILE RADIO SERVICES.

[FCC Rules Part 24:](#) PUBLIC MOBILE SERVICES

[FCC Rules Part 27:](#) MISCELLANEOUS WIRDELESS COMMUNICATIONS SERVICES

[ANSI C63.26: 2015:](#) American National Standard for Compliance Testing of Transmitters Used in Licensed Radio Services

[KDB 971168 D01 Power Meas License Digital Systems v03:](#) MEASUREMENT GUIDANCE FOR CERTIFICATION OF LICENSED DIGITAL TRANSMITTERS

1.2. Report version

Revised No.	Date of issue	Description
01	2018-11-25	Original



1.3. Test Description

Test Item	Section in CFR 47	Result	Test Engineer
Conducted Output Power	Part 2.1046 Part 22.913(a) Part 24.232(c) Part 27.50	Pass	Young He
Peak-to-Average Ratio	Part 24.232 Part 27.50	Pass	Young He
99% Occupied Bandwidth & 26 dB Bandwidth	Part 2.1049 Part 22.917(b) Part 24.238(b) Part 27.53	Pass	Young He
Band Edge	Part 2.1051 Part 22.917 Part 24.238 Part 27.53	Pass	Young He
Conducted Spurious Emissions	Part 2.1051 Part 22.917 Part 24.238 Part 27.53	Pass	Young He
Frequency stability VS Temperature	Part 2.1055(a)(1)(b) Part 22.355 Part 24.235 Part 27.54	Pass	Young He
Frequency stability VS Voltage	Part 2.1055(d)(1)(2) Part 22.355 Part 24.235 Part 27.54	Pass	Young He
ERP and EIRP	Part 22.913(a) Part 24.232(b) Part 27.50	Pass	Young He
Radiated Spurious Emissions	Part 2.1053 Part 22.917 Part 24.238 Part 27.53	Pass	Young He

Note: The measurement uncertainty is not included in the test result.



1.4. Test Facility

Address of the test laboratory

Shenzhen General Testing & Inspection Technology Co., Ltd.

Add: 1F, 2 Block, Jiaquan Building, Guanlan High-tech Park Baoan District, Shenzhen, Guangdong, China

Laboratory accreditation

The test facility is recognized, certified, or accredited by the following organizations:

CNAS-Lab Code: L5365

Shenzhen General Testing & Inspection Technology Co., Ltd. has been assessed and proved to be in Compliance with CNAS-CL01 Accreditation Criteria for Testing and Calibration Laboratories (identical to ISO/IEC 17025: 2005 General Requirements) for the Competence of Testing and Calibration Laboratories.

A2LA-Lab Cert. No.: CN1208

Shenzhen General Testing & Inspection Technology Co., Ltd. EMC Laboratory has been accredited by A2LA for technical competence in the field of electrical testing, and proved to be in compliance with ISO/IEC 17025:2005 General Requirements for the Competence of Testing and Calibration Laboratories and any additional program requirements in the identified field of testing.

IC Registration No.: 9783A-1

The 3m alternate test site of Shenzhen General Testing & Inspection Technology Co., Ltd. EMC Laboratory has been registered by Certification and Engineer Bureau of Industry Canada for the performance of with Registration NO.: 9783A on Jan, 2016.

FCC-Registration No.: 951311

Shenzhen General Testing & Inspection Technology Co., Ltd. EMC Laboratory has been registered and fully described in a report filed with the (FCC) Federal Communications Commission. The acceptance letter from the FCC is maintained in our files. Registration 951311, Aug 26, 2017

1.5. Measurement Uncertainty

The data and results referenced in this document are true and accurate. The reader is cautioned that there may be errors within the calibration limits of the equipment and facilities. The measurement uncertainty was calculated for all measurements listed in this test report acc. To CISPR 16 – 4 Specification for radio disturbance and immunity measuring apparatus and methods – Part 4: Uncertainty in EMC Measurements and is documented in the Shenzhen General Testing & Inspection Technology Co., Ltd quality system acc. To DIN EN ISO/IEC 17025. Furthermore, component and process variability of devices similar to that tested may result in additional deviation. The manufacturer has the sole responsibility of continued compliance of the device.

Hereafter the best measurement capability for General Testing & Inspection laboratory is reported:



Test Items	Measurement Uncertainty	Notes
Frequency stability	25 Hz	(1)
Transmitter power conducted	0.57 dB	(1)
Transmitter power Radiated	2.20 dB	(1)
Conducted spurious emission 9KHz-12.75 GHz	1.60 dB	(1)
Conducted Emission 9KHz-30MHz	3.39 dB	(1)
Radiated Emission 30~1000MHz	4.24 dB	(1)
Radiated Emission 1~18GHz	5.16 dB	(1)
Radiated Emission 18-40GHz	5.54 dB	(1)
Occupied Bandwidth	-----	(1)
Emission Mask	-----	(1)
Modulation Characteristic	-----	(1)
Transmitter Frequency Behavior	-----	(1)

Note: This uncertainty represents an expanded uncertainty expressed at approximately the 95% confidence level using a coverage factor of $k=1.96$.

1.6. Environmental conditions

During the measurement the environmental conditions were within the listed ranges:

Normal Temperature:	25°C
Relative Humidity:	55 %
Air Pressure:	101 kPa



2. GENERAL INFORMATION

2.1. Client Information

Applicant:	PeopleNet Communications Corporation
Address:	4400 Baker Road, Minnetonka, Minnesota, United States
Manufacturer:	STONKAM CO.,LTD.
Address:	5/F., #3 Building, Huangzhou Industrial Park, Chebei Rd., Tianhe Dist., 510665 Guangzhou, China

2.2. General Description of EUT

Product Name:	DVR S597
Model/Type reference:	E-006-0597
Marketing Name:	N/A
Listed Model(s):	N/A
Power supply:	12Vdc from Li-ion Battery
Hardware version:	Rev 1.502
Software version:	DV423V1.0.0
LTE	
Operation Band:	Band 2: UL: 1850.7MHz~1909.3MHz, DL: 1930.7MHz~1989.3MHz Band 4: UL: 1710.7MHz~1754.3MHz, DL: 2110.7MHz~2154.3MHz Band 5: UL: 824.7MHz~848.3MHz, DL: 869.7MHz~893.3MHz Band 12: UL: 699.7MHz~715.3MHz, DL: 729.7MHz~745.3MHz
Modulation Type:	QPSK, 16QAM
Antenna type:	Main Antenna is External Antenna Diversity Antenna is FPC Antenna
Antenna Gain:	Main Antenna: FDD Band 2: 4.16dBi FDD Band 4: 4.16dBi FDD Band 5: 3.34dBi FDD Band 12: 3.34dBi



2.3. Description of Test Modes and Test Frequency

The EUT has been tested under typical operating condition. The CMW500 used to control the EUT staying in continuous transmitting and receiving mode for testing.

Test Frequency:

Band 2			
Test channel	Bandwidth(MHz)	N _{UL}	Frequency of Uplink (MHz)
Low Range	1.4	18607	1850.70
	3	18615	1851.50
	5	18625	1852.50
	10	18650	1855.00
	15	18675	1857.50
	20	18700	1860.00
Mid Range	1.4/3/5/10/15/20	18900	1880.00
High Range	1.4	19193	1909.30
	3	19185	1908.50
	5	19175	1907.50
	10	19150	1905.00
	15	19125	1902.50
	20	19100	1900.00

Band 4			
Test channel	Bandwidth(MHz)	N _{UL}	Frequency of Uplink (MHz)
Low Range	1.4	19957	1710.70
	3	19965	1711.50
	5	19975	1712.50
	10	20000	1715.00
	15	20025	1717.50
	20	20050	1720.00
Mid Range	1.4/3/5/10/15/20	20175	1732.50
High Range	1.4	20393	1754.30
	3	20385	1753.50
	5	20375	1752.50
	10	20350	1750.00
	15	20325	1747.50
	20	20300	1745.00

Band 5			
Test channel	Bandwidth(MHz)	N _{UL}	Frequency of Uplink (MHz)
Low Range	1.4	20407	824.70
	3	20415	825.50
	5	20425	826.50
	10	20450	829.00
Mid Range	1.4/3/5/10	20525	836.50
High Range	1.4	20643	848.30
	3	20635	847.50
	5	20625	846.50
	10	20600	844.00



Band 12			
Test channel	Bandwidth(MHz)	N _{UL}	Frequency of Uplink (MHz)
Low Range	1.4	23017	699.70
	3	23025	700.50
	5	23035	701.50
	10	23060	704.00
Mid Range	1.4/3/5/10	23095	707.50
High Range	1.4	23173	715.30
	3	23165	714.50
	5	23155	713.50
	10	23130	711.00



2.4. Measurement Instruments List

Output Power (Radiated) & Radiated Spurious Emission					
Item	Test Equipment	Manufacturer	Model No.	Serial No.	Calibrated until
1	EMI Test Receiver	R&S	ESCI	100967	Jan. 04, 2019
2	High pass filter	Compliance Direction systems	BSU-6	34202	Jan. 04, 2019
3	Log-Bicon Antenna	Schwarzbeck	CBL6141A	4180	Jan. 04, 2019
4	Log-Bicon Antenna	Schwarzbeck	CBL6141A	4181	Jan. 04, 2019
5	Spectrum Analyzer	HP	8563E	02052	Jan. 04, 2019
6	Horn Antenna	Schwarzbeck	BBHA 9120D	648	Jan. 04, 2019
7	Horn Antenna	Schwarzbeck	BBHA 9120D	649	Jan. 04, 2019
8	Ultra-Broadband Antenna	ShwarzBeck	BBHA9170	25841	Jan. 04, 2019
9	Ultra-Broadband Antenna	ShwarzBeck	BBHA9170	25842	Jan. 04, 2019
10	Pre-Amplifier	HP	8447D	1937A03050	Jan. 04, 2019
11	Pre-Amplifier	EMCI	EMC051835	980075	Jan. 04, 2019
12	Splitter	Mini-Circuit	ZAPD-4	400059	Jan. 04, 2019
13	Signal Generator	Agilent	N5182A	1019356	Jan. 04, 2019
14	UNIVERSAL RADIO COMMUNICATION	Rohde & Schwarz	CMU200	114694	Jan. 04, 2019
15	Antenna Mast	UC	UC3000	N/A	N/A
16	Antenna mast	MATURO	TAM-4.0-P	N/A	N/A
17	Turn Table	UC	UC3000	N/A	N/A
18	Cable Below 1GHz	Schwarzbeck	AK9515E	33155	Jan. 04, 2019
19	Cable Above 1GHz	Hubersuhner	SUCOFLEX102	DA1580	Jan. 04, 2019

Output Power(Conducted) & Occupied Bandwidth & Emission Bandwidth & Band Edge Compliance & Conducted Spurious Emission					
Item	Test Equipment	Manufacturer	Model No.	Serial No.	Calibrated until
1	UNIVERSAL RADIO COMMUNICATION	Rohde & Schwarz	CMU200	114694	Jan. 04, 2019
2	Spectrum Analyzer	Rohde & Schwarz	FSU	100105	Jan. 04, 2019
3	Spectrum Analyzer	Rohde & Schwarz	FUV40-N	101331	Jun. 22, 2019
4	Splitter	Mini-Circuit	ZAPD-4	400059	Jan. 04, 2019

Frequency Stability					
Item	Test Equipment	Manufacturer	Model No.	Serial No.	Calibrated until
1	UNIVERSAL RADIO COMMUNICATION	Rohde & Schwarz	CMU200	114694	Jan. 04, 2019
2	Spectrum Analyzer	Rohde & Schwarz	FSU	100105	Jan. 04, 2019
3	Spectrum Analyzer	Rohde & Schwarz	FUV40-N	101331	Jun. 22, 2019
4	Splitter	Mini-Circuit	ZAPD-4	400059	Jan. 04, 2019
5	Climate Chamber	ESPEC	EL-10KA	05107008	Jan. 04, 2019

Note: 1. The Cal. Interval was one year.

2. The cable loss has calculated in test result which connection between each test instruments.



3. TEST ITEM AND RESULTS

3.1. Conducted Output Power

LIMIT

Conducted Output Power: N/A

TEST CONFIGURATION



Note: Measurement setup for testing on Antenna connector

TEST PROCEDURE

1. The transmitter output port was connected to base station.
2. The RF output of EUT was connected to the power meter by RF cable and attenuator, the path loss was compensated to the results for each measurement.
3. Set EUT at maximum power through base station.
4. Select lowest, middle, and highest channels for each band and different modulation.
5. Measure the maximum PK burst power and maximum Avg. burst power.

TEST RESULTS

Please see the Appendix for every tested Band.

3.2. Peak-to-Average Ratio

LIMIT:

The Peak-to-Average Ratio (PAR) of the transmission may not exceed 13dB.

TEST CONFIGURATION

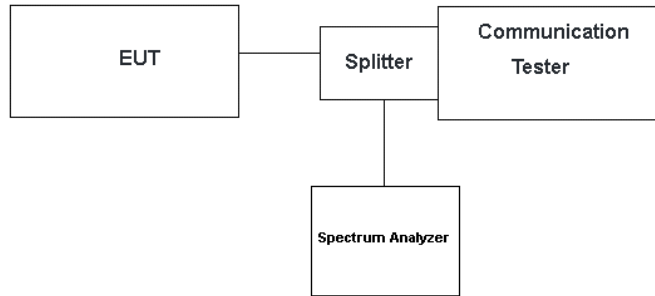

TEST PROCEDURE

1. The testing follows FCC KDB 971168 v02r02 Section 5.7.1.
2. The EUT was connected to spectrum and communication tester via a splitter
3. Set the CCDF (Complementary Cumulative Distribution Function) option in spectrum analyzer.
4. The highest RF powers were measured and recorded the maximum PAPR level associated with a probability of 0.1 %.
6. Record the deviation as Peak to Average Ratio.

TEST RESULTS

Please see the Appendix for every tested Band.



3.3. Occupy Bandwidth

TEST CONFIGURATION

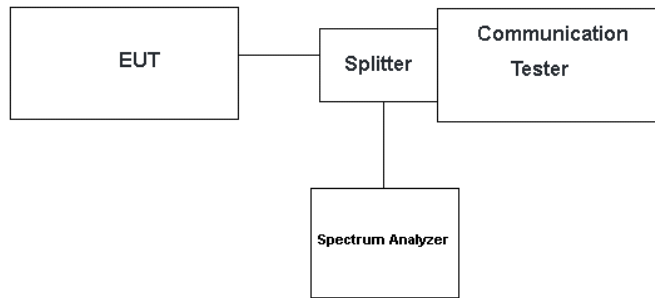

TEST PROCEDURE

1. The EUT's output RF connector was connected with a short cable to the spectrum analyzer
2. RBW was set to about 1% of emission BW, VBW ≥ 3 times RBW.
3. -26dBc display line was placed on the screen (or 99% bandwidth), the occupied bandwidth is the delta frequency between the two points where the display line intersects the signal trace.

TEST RESULTS

Please see the Appendix for every tested Band.



3.4. Out of band emission at antenna terminals

LIMIT

FDD Band 2: The power of any emission outside of the authorized operating frequency ranges must be attenuated below the transmitting power (P) by a factor of at least $43 + 10 \log(P)$ dB.

FDD Band 4: The power of any emission outside a licensee's frequency block shall be attenuated below the transmitter power (P) in watts by at least $43 + 10 \log_{10}(P)$ dB.

FDD Band 5: The power of any emission outside of the authorized operating frequency ranges must be attenuated below the transmitting power (P) by a factor of at least $43 + 10 \log(P)$ dB.

FDD Band 12: The power of any emission outside a licensee's frequency band(s) of operation shall be attenuated below the transmitter power (P) within the licensed band(s) of operation, measured in watts, by at least $43 + 10 \log(P)$ dB.

TEST CONFIGURATION

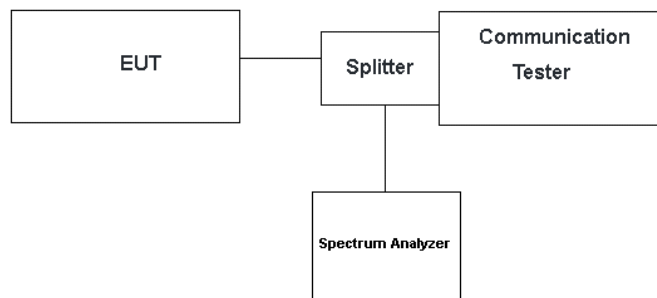

TEST PROCEDURE

1. The RF output of the transceiver was connected to a spectrum analyzer through appropriate attenuation.
2. The resolution bandwidth of the spectrum analyzer was set at 1MHz; sufficient scans were taken to show the out of band Emissions if any up to 10th harmonic.
3. For the out of band: Set the RBW = 1MHz VBW ≥ 3 times RBW, Start=30MHz, Stop= 10th harmonic.

TEST RESULTS

Please see the Appendix for every tested Band.



3.5. Band Edge compliance

LIMIT

FDD Band 2: The power of any emission outside of the authorized operating frequency ranges must be attenuated below the transmitting power (P) by a factor of at least $43 + 10 \log(P)$ dB.

FDD Band 4: The power of any emission outside a licensee's frequency block shall be attenuated below the transmitter power (P) in watts by at least $43 + 10 \log_{10}(P)$ dB.

FDD Band 5: The power of any emission outside of the authorized operating frequency ranges must be attenuated below the transmitting power (P) by a factor of at least $43 + 10 \log(P)$ dB.

FDD Band 12: The power of any emission outside a licensee's frequency band(s) of operation shall be attenuated below the transmitter power (P) within the licensed band(s) of operation, measured in watts, by at least $43 + 10 \log(P)$ dB.

TEST CONFIGURATION

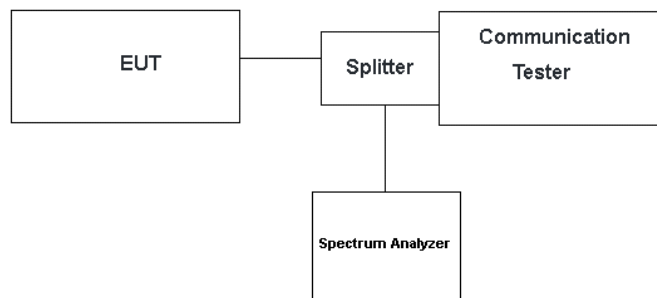

TEST PROCEDURE

1. The RF output of the transceiver was connected to a spectrum analyzer through appropriate attenuation.
2. RBW was set to about 1% of emission BW, $VBW \geq 3$ times RBW.

TEST RESULTS

Please see the Appendix for every tested Band.

3.6. Radiated Power Measurement

LIMIT

LTE FDD Band 2: 2W(33dBm) EIRP
 LTE FDD Band 4: 1W(30dBm) EIRP
 LTE FDD Band 5: 7W(38.45dBm) ERP
 LTE FDD Band 12: 3W(34.77dBm) EPR

TEST CONFIGURATION

For the actual test configuration, please refer to the related Item – EUT Test Photos.

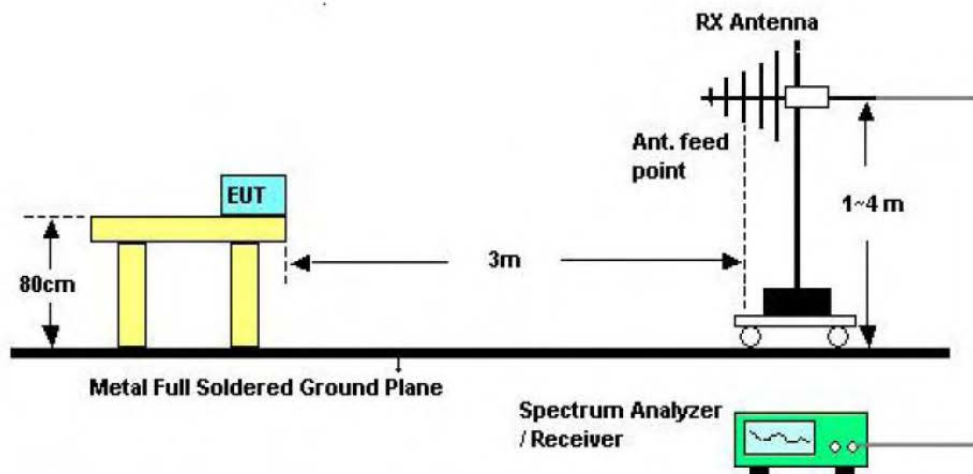

Below 1GHz

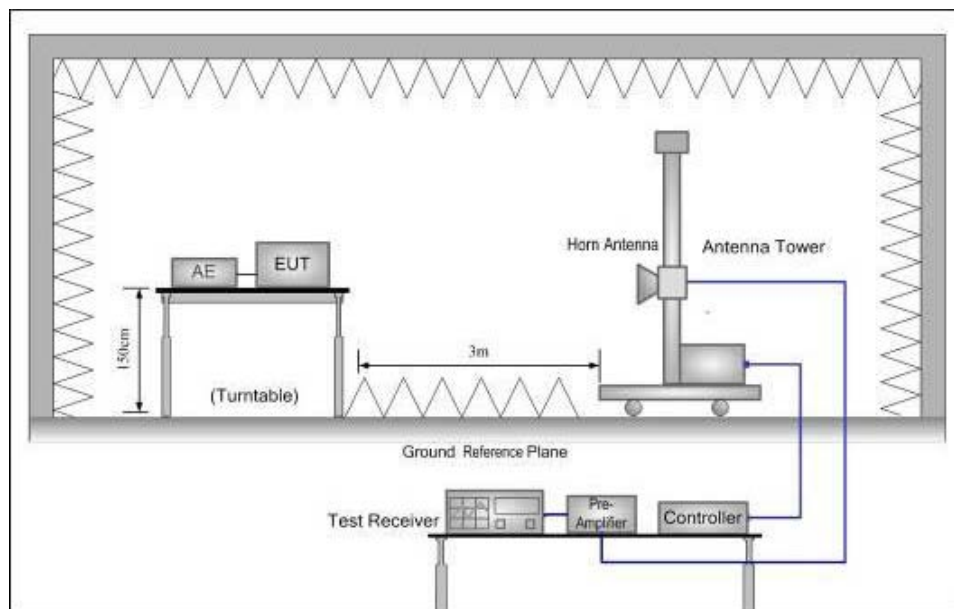

Above 1GHz



TEST PROCEDURE

1. EUT was placed on a 1.50 meter high non-conductive stand at a 3 meter test distance from the receive antenna. A receiving antenna was placed on the antenna mast 3 meters from the EUT for emission measurements. The height of receiving antenna is 1.50m. Detected emissions were maximized at each frequency by rotating the EUT through 360° and adjusting the receiving antenna polarization. The radiated emission measurements of all transmit frequencies in three channels (High, Middle, Low) were measured with peak detector.
2. A log-periodic antenna or double-ridged waveguide horn antenna shall be substituted in place of the EUT. The log-periodic antenna will be driven by a signal generator and the level will be adjusted till the same power value on the spectrum analyzer or receiver. The level of the spurious emissions can be calculated through the level of the signal generator, cable loss, the gain of the substitution antenna and the reading of the spectrum analyzer or receiver.
3. The EUT is then put into continuously transmitting mode at its maximum power level during the test. Set Test Receiver or Spectrum RBW=1MHz, VBW=3MHz, and the maximum value of the receiver should be recorded as (Pr).
4. The EUT shall be replaced by a substitution antenna. In the chamber, an substitution antenna for the frequency band of interest is placed at the reference point of the chamber. An RF Signal source for the frequency band of interest is connected to the substitution antenna with a cable that has been constructed to not interfere with the radiation pattern of the antenna. A power (PMea) is applied to the input of the substitution antenna, and adjusts the level of the signal generator output until the value of the receiver reach the previously recorded (Pr). The power of signal source (PMea) is recorded. The test should be performed by rotating the test item and adjusting the receiving antenna polarization.
5. An amplifier should be connected to the Signal Source output port. And the cable should be connecting between the Amplifier and the Substitution Antenna. The cable loss (Pcl), the Substitution Antenna Gain (Ga) and the Amplifier Gain (PAg) should be recorded after test.
6. The measurement results are obtained as described below:
Power(EIRP)=PMea- PAg - Pcl + Ga
We used N5182A microwave signal generator which signal level can up to 33dBm,so we not used power Amplifier for substitution test; The measurement results are amend as described below:
Power(EIRP)=PMea- Pcl + Ga
7. This value is EIRP since the measurement is calibrated using an antenna of known gain (2.15 dBi) and known input power.
ERP can be calculated from EIRP by subtracting the gain of the dipole, ERP = EIRP-2.15dBi.

TEST RESULTS

Remark:

1. By preliminary testing and verifying three axis (X, Y and Z) position of EUT transmitted status, it was found that “Z axis” position was the worst, and test data recorded in this report.



LTE Band 2 - 1.4MHz					
Modulation	Channel	EIRP (dBm)		Limit (dBm)	Result
		Vertical	Horizontal		
QPSK	Low	20.72	18.50	≤33	PASS
	Mid	20.77	18.76		
	High	20.61	19.10		
16QAM	Low	20.45	19.31		
	Mid	20.60	18.60		
	High	20.94	19.01		

LTE Band 2 - 3MHz					
Modulation	Channel	EIRP (dBm)		Limit (dBm)	Result
		Vertical	Horizontal		
QPSK	Low	20.41	18.97	≤33	PASS
	Mid	20.53	18.59		
	High	21.03	18.74		
16QAM	Low	20.68	18.93		
	Mid	20.87	19.18		
	High	20.37	18.89		

LTE Band 2 - 5MHz					
Modulation	Channel	EIRP (dBm)		Limit (dBm)	Result
		Vertical	Horizontal		
QPSK	Low	20.89	18.86	≤33	PASS
	Mid	21.13	18.67		
	High	21.05	18.72		
16QAM	Low	20.92	18.68		
	Mid	20.63	18.50		
	High	20.63	18.65		



LTE Band 2 - 10MHz					
Modulation	Channel	EIRP (dBm)		Limit (dBm)	Result
		Vertical	Horizontal		
QPSK	Low	21.08	18.40	≤33	PASS
	Mid	20.60	18.61		
	High	20.76	19.04		
16QAM	Low	20.62	19.16		
	Mid	20.83	19.23		
	High	20.52	19.03		

LTE Band 2 - 15MHz					
Modulation	Channel	EIRP (dBm)		Limit (dBm)	Result
		Vertical	Horizontal		
QPSK	Low	21.01	18.51	≤33	PASS
	Mid	20.42	18.88		
	High	20.48	18.67		
16QAM	Low	20.66	18.41		
	Mid	20.25	19.31		
	High	20.63	18.93		

LTE Band 2 - 20MHz					
Modulation	Channel	EIRP (dBm)		Limit (dBm)	Result
		Vertical	Horizontal		
QPSK	Low	20.43	18.61	≤33	PASS
	Mid	20.81	19.04		
	High	21.14	18.95		
16QAM	Low	20.62	18.60		
	Mid	21.10	19.29		
	High	20.97	19.15		



LTE Band 4 - 1.4MHz					
Modulation	Channel	EIRP (dBm)		Limit (dBm)	Result
		Vertical	Horizontal		
QPSK	Low	20.56	18.79	≤33	PASS
	Mid	20.91	19.25		
	High	20.77	19.01		
16QAM	Low	21.05	18.38		
	Mid	21.12	18.35		
	High	21.20	18.37		

LTE Band 4 - 3MHz					
Modulation	Channel	EIRP (dBm)		Limit (dBm)	Result
		Vertical	Horizontal		
QPSK	Low	20.33	19.29	≤33	PASS
	Mid	20.70	18.77		
	High	20.46	18.63		
16QAM	Low	20.81	18.80		
	Mid	21.14	18.67		
	High	20.61	18.66		

LTE Band 4 - 5MHz					
Modulation	Channel	EIRP (dBm)		Limit (dBm)	Result
		Vertical	Horizontal		
QPSK	Low	20.73	19.22	≤33	PASS
	Mid	20.74	18.59		
	High	20.35	18.86		
16QAM	Low	20.80	18.39		
	Mid	21.11	18.95		
	High	20.91	18.87		



LTE Band 4 - 10MHz					
Modulation	Channel	EIRP (dBm)		Limit (dBm)	Result
		Vertical	Horizontal		
QPSK	Low	20.98	18.70	≤33	PASS
	Mid	20.25	18.62		
	High	20.62	18.45		
16QAM	Low	21.07	18.54		
	Mid	20.67	19.08		
	High	20.33	19.33		

LTE Band 4 - 15MHz					
Modulation	Channel	EIRP (dBm)		Limit (dBm)	Result
		Vertical	Horizontal		
QPSK	Low	21.18	19.24	≤33	PASS
	Mid	21.12	19.04		
	High	20.28	19.17		
16QAM	Low	20.46	18.36		
	Mid	21.06	18.88		
	High	20.63	18.42		

LTE Band 4 - 20MHz					
Modulation	Channel	EIRP (dBm)		Limit (dBm)	Result
		Vertical	Horizontal		
QPSK	Low	21.52	18.75	≤33	PASS
	Mid	20.84	18.48		
	High	20.81	19.26		
16QAM	Low	20.36	18.54		
	Mid	20.89	18.66		
	High	20.50	19.23		



LTE Band 5 - 1.4MHz					
Modulation	Channel	ERP (dBm)		Limit (dBm)	Result
		Vertical	Horizontal		
QPSK	Low	23.24	19.40	≤33	PASS
	Mid	22.78	19.29		
	High	23.10	18.67		
16QAM	Low	23.28	18.68		
	Mid	22.40	18.95		
	High	23.52	18.77		

LTE Band 5 - 3MHz					
Modulation	Channel	ERP (dBm)		Limit (dBm)	Result
		Vertical	Horizontal		
QPSK	Low	23.63	19.27	≤33	PASS
	Mid	23.65	18.70		
	High	23.29	18.88		
16QAM	Low	23.09	19.09		
	Mid	22.57	18.83		
	High	23.60	18.96		

LTE Band 5 - 5MHz					
Modulation	Channel	ERP (dBm)		Limit (dBm)	Result
		Vertical	Horizontal		
QPSK	Low	23.35	18.49	≤33	PASS
	Mid	23.43	19.08		
	High	23.77	18.46		
16QAM	Low	23.57	19.23		
	Mid	23.29	18.74		
	High	23.33	18.80		



LTE Band 5 - 10MHz					
Modulation	Channel	ERP (dBm)		Limit (dBm)	Result
		Vertical	Horizontal		
QPSK	Low	23.78	18.66	≤33	PASS
	Mid	23.48	19.16		
	High	22.89	18.58		
16QAM	Low	23.49	18.41		
	Mid	23.02	19.14		
	High	23.61	18.41		



LTE Band 12 - 1.4MHz					
Modulation	Channel	ERP (dBm)		Limit (dBm)	Result
		Vertical	Horizontal		
QPSK	Low	23.34	18.36	≤33	PASS
	Mid	23.31	18.36		
	High	22.75	18.85		
16QAM	Low	23.05	18.65		
	Mid	23.38	18.66		
	High	22.96	18.57		

LTE Band 12 - 3MHz					
Modulation	Channel	ERP (dBm)		Limit (dBm)	Result
		Vertical	Horizontal		
QPSK	Low	23.26	18.56	≤33	PASS
	Mid	22.91	19.09		
	High	22.80	19.35		
16QAM	Low	22.78	19.15		
	Mid	23.40	19.16		
	High	23.04	18.68		

LTE Band 12 - 5MHz					
Modulation	Channel	ERP (dBm)		Limit (dBm)	Result
		Vertical	Horizontal		
QPSK	Low	23.47	18.86	≤33	PASS
	Mid	22.73	18.67		
	High	23.33	18.66		
16QAM	Low	22.77	18.54		
	Mid	22.86	18.51		
	High	22.79	19.21		



LTE Band 12 -10MHz					
Modulation	Channel	ERP (dBm)		Limit (dBm)	Result
		Vertical	Horizontal		
QPSK	Low	23.10	19.12	≤33	PASS
	Mid	23.47	18.71		
	High	23.64	18.58		
16QAM	Low	22.87	18.86		
	Mid	23.05	18.91		
	High	23.67	18.46		

3.7. Radiated Spurious Emission

LIMIT

FDD Band 2: The power of any emission outside of the authorized operating frequency ranges must be attenuated below the transmitting power (P) by a factor of at least $43 + 10 \log(P)$ dB.

FDD Band 4: The power of any emission outside a licensee's frequency block shall be attenuated below the transmitter power (P) in watts by at least $43 + 10 \log_{10}(P)$ dB.

FDD Band 5: The power of any emission outside of the authorized operating frequency ranges must be attenuated below the transmitting power (P) by a factor of at least $43 + 10 \log(P)$ dB.

FDD Band 12: the power of any emission outside a licensee's frequency band(s) of operation shall be attenuated below the transmitter power (P) within the licensed band(s) of operation, measured in watts, by at least $43 + 10 \log(P)$ dB.

TEST CONFIGURATION

For the actual test configuration, please refer to the related Item – EUT Test Photos.

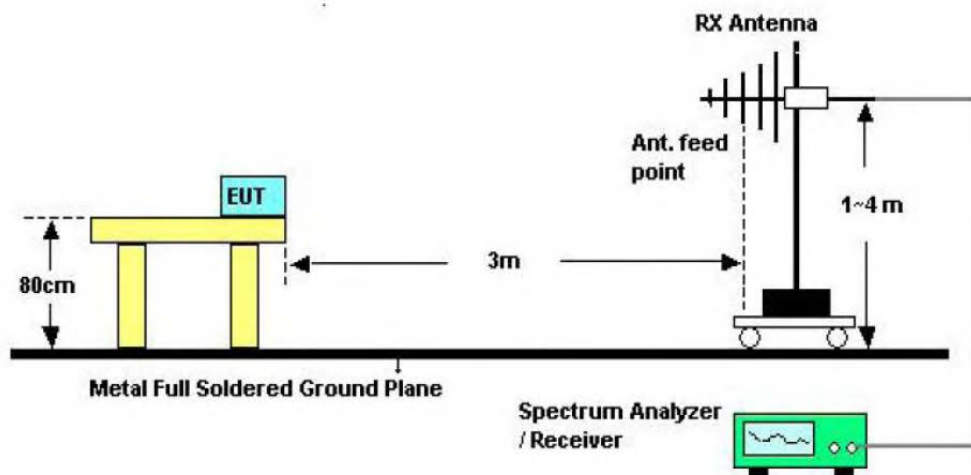

Below 1GHz

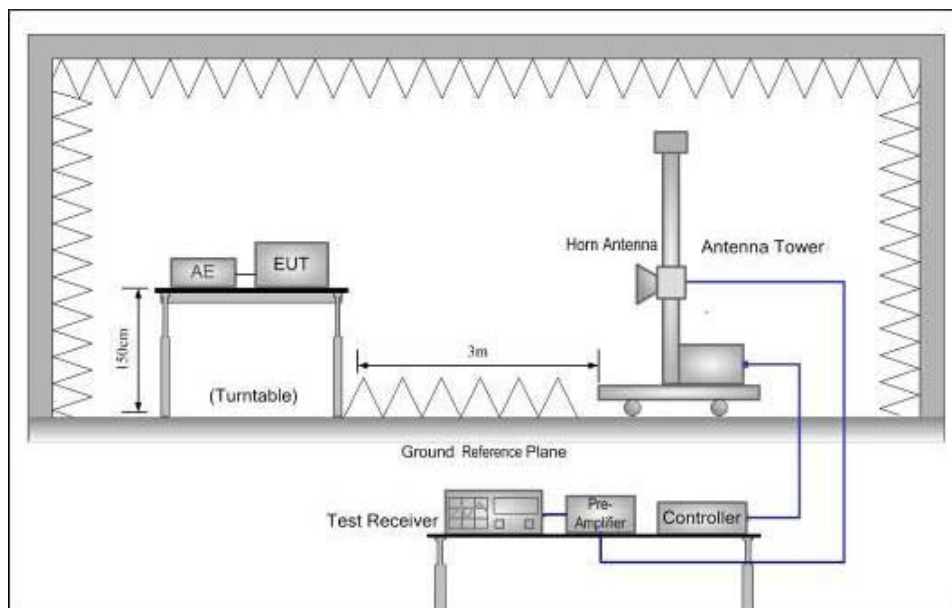

Above 1GHz



TEST PROCEDURE

1. EUT was placed on a 1.50 meter high non-conductive stand at a 3 meter test distance from the receive antenna. A receiving antenna was placed on the antenna mast 3 meters from the EUT for emission measurements. The height of receiving antenna is 1.50m. Detected emissions were maximized at each frequency by rotating the EUT through 360° and adjusting the receiving antenna polarization. The radiated emission measurements of all transmit frequencies in three channels (High, Middle, Low) were measured with peak detector.
2. A log-periodic antenna or double-ridged waveguide horn antenna shall be substituted in place of the EUT. The log-periodic antenna will be driven by a signal generator and the level will be adjusted till the same power value on the spectrum analyzer or receiver. The level of the spurious emissions can be calculated through the level of the signal generator, cable loss, the gain of the substitution antenna and the reading of the spectrum analyzer or receiver.
3. The EUT is then put into continuously transmitting mode at its maximum power level during the test. Set Test Receiver or Spectrum RBW=1MHz, VBW=3MHz, and the maximum value of the receiver should be recorded as (Pr).
4. The EUT shall be replaced by a substitution antenna. In the chamber, an substitution antenna for the frequency band of interest is placed at the reference point of the chamber. An RF Signal source for the frequency band of interest is connected to the substitution antenna with a cable that has been constructed to not interfere with the radiation pattern of the antenna. A power (PMea) is applied to the input of the substitution antenna, and adjusts the level of the signal generator output until the value of the receiver reach the previously recorded (Pr). The power of signal source (PMea) is recorded. The test should be performed by rotating the test item and adjusting the receiving antenna polarization.
5. An amplifier should be connected to the Signal Source output port. And the cable should be connecting between the Amplifier and the Substitution Antenna. The cable loss (Pcl), the Substitution Antenna Gain (Ga) and the Amplifier Gain (PAg) should be recorded after test.
6. The measurement results are obtained as described below:
Power(EIRP)=PMea- PAg - Pcl + Ga
We used SMF100A microwave signal generator which signal level can up to 33dBm,so we not used power Amplifier for substitution test; The measurement results are amend as described below:
Power(EIRP)=PMea- Pcl + Ga
7. This value is EIRP since the measurement is calibrated using an antenna of known gain (2.15 dBi) and known input power.
ERP can be calculated from EIRP by subtracting the gain of the dipole, ERP = EIRP-2.15dBi.
8. Test frequency range should extend to 10th harmonic of highest fundamental frequency.

TEST RESULTS

Remark:

1. By preliminary testing and verifying three axis (X, Y and Z) position of EUT transmitted status, it was found that "Z axis" position was the worst, and test data recorded in this report.
2. We test all modulation type and record worst case at Voice mode.
3. No report for the emission which more than 10 dB below the prescribed limit.



Measured data (worst case):

Band 2 Radiated Spurious Emissions							
Bandwidth	Modulation	Test Channel	Spurious Emission			Limit (dBm)	Result
			Frequency	Level (dBm)	Polarization		
1.4MHz	QPSK	L	3701.40	-41.37	Vertical	-13.00	Pass
			5552.10	-47.71	Vertical		
			3701.40	-47.45	Horizontal		
			5552.10	-53.46	Horizontal		
1.4MHz	QPSK	M	3760.00	-42.57	Vertical	-13.00	Pass
			5640.00	-48.17	Vertical		
			3760.00	-42.94	Horizontal		
			5640.00	-52.99	Horizontal		
1.4MHz	QPSK	H	3818.60	-42.49	Vertical	-13.00	Pass
			5727.90	-47.60	Vertical		
			3818.60	-40.50	Horizontal		
			5727.90	-52.62	Horizontal		
3MHz	QPSK	L	3703.00	-40.39	Vertical	-13.00	Pass
			5554.50	-48.94	Vertical		
			3703.00	-42.78	Horizontal		
			5554.50	-53.98	Horizontal		
3MHz	QPSK	M	3760.00	-40.50	Vertical	-13.00	Pass
			5640.00	-47.05	Vertical		
			3760.00	-42.51	Horizontal		
			5640.00	-52.54	Horizontal		
3MHz	QPSK	H	3817.00	-42.24	Vertical	-13.00	Pass
			5725.50	-47.50	Vertical		
			3817.00	-42.63	Horizontal		
			5725.50	-52.40	Horizontal		

Remark :

1. The emission behavior belongs to narrowband spurious emission.
2. The emission levels of below 1 GHz are very lower than the limit above 10dB and not show in test report.



Band 2 Radiated Spurious Emissions							
Bandwidth	Modulation	Test Channel	Spurious Emission			Limit (dBm)	Result
			Frequency	Level (dBm)	Polarization		
5MHz	QPSK	L	3705.00	-41.57	Vertical	-13.00	Pass
			5557.50	-47.67	Vertical		
			3705.00	-47.40	Horizontal		
			5557.50	-53.70	Horizontal		
5MHz	QPSK	M	3760.00	-41.51	Vertical	-13.00	Pass
			5640.00	-48.04	Vertical		
			3760.00	-41.56	Horizontal		
			5640.00	-54.01	Horizontal		
5MHz	QPSK	H	3815.00	-42.50	Vertical	-13.00	Pass
			5722.50	-47.69	Vertical		
			3815.00	-42.79	Horizontal		
			5722.50	-54.68	Horizontal		
10MHz	QPSK	L	3710.00	-42.05	Vertical	-13.00	Pass
			5565.00	-48.09	Vertical		
			3710.00	-42.81	Horizontal		
			5565.00	-54.72	Horizontal		
10MHz	QPSK	M	3760.00	-41.21	Vertical	-13.00	Pass
			5640.00	-47.91	Vertical		
			3760.00	-41.01	Horizontal		
			5640.00	-52.39	Horizontal		
10MHz	QPSK	H	3810.00	-42.03	Vertical	-13.00	Pass
			5715.00	-47.05	Vertical		
			3810.00	-42.07	Horizontal		
			5715.00	-52.03	Horizontal		

Remark :

1. The emission behavior belongs to narrowband spurious emission.
2. The emission levels of below 1 GHz are very lower than the limit above 10dB and not show in test report.



Band 2 Radiated Spurious Emissions							
Bandwidth	Modulation	Test Channel	Spurious Emission			Limit (dBm)	Result
			Frequency	Level (dBm)	Polarization		
15MHz	QPSK	L	3715.00	-40.84	Vertical	-13.00	Pass
			5572.50	-48.47	Vertical		
			3715.00	-45.10	Horizontal		
			5572.50	-53.68	Horizontal		
15MHz	QPSK	M	3760.00	-42.95	Vertical	-13.00	Pass
			5640.00	-47.97	Vertical		
			3760.00	-41.33	Horizontal		
			5640.00	-52.28	Horizontal		
15MHz	QPSK	H	3805.00	-41.28	Vertical	-13.00	Pass
			5707.50	-49.90	Vertical		
			3805.00	-42.90	Horizontal		
			5707.50	-52.99	Horizontal		
20MHz	QPSK	L	3720.00	-41.41	Vertical	-13.00	Pass
			5580.00	-48.33	Vertical		
			3720.00	-40.70	Horizontal		
			5580.00	-54.54	Horizontal		
20MHz	QPSK	M	3760.00	-40.72	Vertical	-13.00	Pass
			5640.00	-48.62	Vertical		
			3760.00	-41.02	Horizontal		
			5640.00	-54.71	Horizontal		
20MHz	QPSK	H	3800.00	-42.22	Vertical	-13.00	Pass
			5700.00	-48.82	Vertical		
			3800.00	-41.56	Horizontal		
			5700.00	-52.99	Horizontal		

Remark :

1. The emission behavior belongs to narrowband spurious emission.
2. The emission levels of below 1 GHz are very lower than the limit above 10dB and not show in test report.



Band 4 Radiated Spurious Emissions							
Bandwidth	Modulation	Test Channel	Spurious Emission			Limit (dBm)	Result
			Frequency	Level (dBm)	Polarization		
1.4MHz	QPSK	L	3421.40	-42.64	Vertical	-13.00	Pass
			5132.10	-47.59	Vertical		
			3421.40	-47.55	Horizontal		
			5132.10	-53.20	Horizontal		
1.4MHz	QPSK	M	3465.00	-42.09	Vertical	-13.00	Pass
			5197.50	-47.37	Vertical		
			3465.00	-41.51	Horizontal		
			5197.50	-54.47	Horizontal		
1.4MHz	QPSK	H	3508.60	-42.43	Vertical	-13.00	Pass
			5262.90	-49.39	Vertical		
			3508.60	-42.30	Horizontal		
			5262.90	-53.71	Horizontal		
3MHz	QPSK	L	3423.00	-40.47	Vertical	-13.00	Pass
			5134.50	-49.94	Vertical		
			3423.00	-40.21	Horizontal		
			5134.50	-54.77	Horizontal		
3MHz	QPSK	M	3465.00	-41.58	Vertical	-13.00	Pass
			5197.50	-49.43	Vertical		
			3465.00	-42.28	Horizontal		
			5197.50	-53.01	Horizontal		
3MHz	QPSK	H	3507.00	-40.47	Vertical	-13.00	Pass
			5260.50	-47.98	Vertical		
			3507.00	-40.58	Horizontal		
			5260.50	-52.98	Horizontal		

Remark :

1. The emission behavior belongs to narrowband spurious emission.
2. The emission levels of below 1 GHz are very lower than the limit above 10dB and not show in test report.



Band 4 Radiated Spurious Emissions							
Bandwidth	Modulation	Test Channel	Spurious Emission			Limit (dBm)	Result
			Frequency	Level (dBm)	Polarization		
5MHz	QPSK	L	3425.00	-40.82	Vertical	-13.00	Pass
			5137.50	-48.77	Vertical		
			3425.00	-47.58	Horizontal		
			5137.50	-53.23	Horizontal		
5MHz	QPSK	M	3465.00	-42.57	Vertical	-13.00	Pass
			5197.50	-47.78	Vertical		
			3465.00	-41.14	Horizontal		
			5197.50	-53.44	Horizontal		
5MHz	QPSK	H	3505.00	-41.85	Vertical	-13.00	Pass
			5257.50	-48.49	Vertical		
			3505.00	-42.39	Horizontal		
			5257.50	-54.24	Horizontal		
10MHz	QPSK	L	3430.00	-40.72	Vertical	-13.00	Pass
			5145.00	-49.98	Vertical		
			3430.00	-40.75	Horizontal		
			5145.00	-53.34	Horizontal		
10MHz	QPSK	M	3465.00	-42.68	Vertical	-13.00	Pass
			5197.50	-47.95	Vertical		
			3465.00	-41.43	Horizontal		
			5197.50	-53.46	Horizontal		
10MHz	QPSK	H	3500.00	-41.43	Vertical	-13.00	Pass
			5250.00	-47.26	Vertical		
			3500.00	-40.79	Horizontal		
			5250.00	-54.45	Horizontal		

Remark :

1. The emission behavior belongs to narrowband spurious emission.
2. The emission levels of below 1 GHz are very lower than the limit above 10dB and not show in test report.



Band 4 Radiated Spurious Emissions							
Bandwidth	Modulation	Test Channel	Spurious Emission			Limit (dBm)	Result
			Frequency	Level (dBm)	Polarization		
15MHz	QPSK	L	3435.00	-41.45	Vertical	-13.00	Pass
			5152.50	-49.44	Vertical		
			3435.00	-47.16	Horizontal		
			5152.50	-54.22	Horizontal		
15MHz	QPSK	M	3465.00	-41.47	Vertical	-13.00	Pass
			5197.50	-47.87	Vertical		
			3465.00	-41.69	Horizontal		
			5197.50	-54.10	Horizontal		
15MHz	QPSK	H	3495.00	-42.32	Vertical	-13.00	Pass
			5242.50	-48.95	Vertical		
			3495.00	-41.82	Horizontal		
			5242.50	-53.50	Horizontal		
20MHz	QPSK	L	3440.00	-40.81	Vertical	-13.00	Pass
			5160.00	-48.09	Vertical		
			3440.00	-40.72	Horizontal		
			5160.00	-52.86	Horizontal		
20MHz	QPSK	M	3465.00	-41.50	Vertical	-13.00	Pass
			5197.50	-47.14	Vertical		
			3465.00	-40.11	Horizontal		
			5197.50	-53.30	Horizontal		
20MHz	QPSK	H	3490.00	-42.29	Vertical	-13.00	Pass
			5235.00	-47.92	Vertical		
			3490.00	-40.04	Horizontal		
			5235.00	-52.54	Horizontal		

Remark :

1. The emission behavior belongs to narrowband spurious emission.
2. The emission levels of below 1 GHz are very lower than the limit above 10dB and not show in test report.



Band 5 Radiated Spurious Emissions							
Bandwidth	Modulation	Test Channel	Spurious Emission			Limit (dBm)	Result
			Frequency	Level (dBm)	Polarization		
1.4MHz	QPSK	L	3421.40	-42.60	Vertical	-13.00	Pass
			5132.10	-48.20	Vertical		
			3421.40	-47.49	Horizontal		
			5132.10	-52.11	Horizontal		
1.4MHz	QPSK	M	3465.00	-41.76	Vertical	-13.00	Pass
			5197.50	-47.69	Vertical		
			3465.00	-42.61	Horizontal		
			5197.50	-54.53	Horizontal		
1.4MHz	QPSK	H	3508.60	-40.16	Vertical	-13.00	Pass
			5262.90	-48.44	Vertical		
			3508.60	-40.53	Horizontal		
			5262.90	-54.34	Horizontal		
3MHz	QPSK	L	3423.00	-41.02	Vertical	-13.00	Pass
			5134.50	-48.36	Vertical		
			3423.00	-41.86	Horizontal		
			5134.50	-53.85	Horizontal		
3MHz	QPSK	M	3465.00	-41.96	Vertical	-13.00	Pass
			5197.50	-48.91	Vertical		
			3465.00	-42.28	Horizontal		
			5197.50	-52.74	Horizontal		
3MHz	QPSK	H	3507.00	-42.85	Vertical	-13.00	Pass
			5260.50	-49.53	Vertical		
			3507.00	-40.71	Horizontal		
			5260.50	-53.30	Horizontal		

Remark :

1. The emission behavior belongs to narrowband spurious emission.
2. The emission levels of below 1 GHz are very lower than the limit above 10dB and not show in test report.



Band 5 Radiated Spurious Emissions							
Bandwidth	Modulation	Test Channel	Spurious Emission			Limit (dBm)	Result
			Frequency	Level (dBm)	Polarization		
5MHz	QPSK	L	3425.00	-41.91	Vertical	-13.00	Pass
			5137.50	-47.53	Vertical		
			3425.00	-47.43	Horizontal		
			5137.50	-54.33	Horizontal		
5MHz	QPSK	M	3465.00	-40.12	Vertical	-13.00	Pass
			5197.50	-47.75	Vertical		
			3465.00	-40.27	Horizontal		
			5197.50	-54.06	Horizontal		
5MHz	QPSK	H	3505.00	-40.15	Vertical	-13.00	Pass
			5257.50	-48.74	Vertical		
			3505.00	-41.27	Horizontal		
			5257.50	-54.39	Horizontal		
10MHz	QPSK	L	3430.00	-42.23	Vertical	-13.00	Pass
			5145.00	-47.72	Vertical		
			3430.00	-40.41	Horizontal		
			5145.00	-52.45	Horizontal		
10MHz	QPSK	M	3465.00	-40.81	Vertical	-13.00	Pass
			5197.50	-47.34	Vertical		
			3465.00	-40.57	Horizontal		
			5197.50	-53.34	Horizontal		
10MHz	QPSK	H	3500.00	-41.86	Vertical	-13.00	Pass
			5250.00	-49.69	Vertical		
			3500.00	-42.34	Horizontal		
			5250.00	-54.05	Horizontal		

Remark :

1. The emission behavior belongs to narrowband spurious emission.
2. The emission levels of below 1 GHz are very lower than the limit above 10dB and not show in test report.



Band 12 Radiated Spurious Emissions							
Bandwidth	Modulation	Test Channel	Spurious Emission			Limit (dBm)	Result
			Frequency	Level (dBm)	Polarization		
1.4MHz	QPSK	L	1399.40	-41.20	Vertical	-13.00	Pass
			2099.10	-47.25	Vertical		
			1399.40	-45.92	Horizontal		
			2099.10	-52.33	Horizontal		
1.4MHz	QPSK	M	1415.00	-41.98	Vertical	-13.00	Pass
			2122.50	-48.75	Vertical		
			1415.00	-41.38	Horizontal		
			2122.50	-52.14	Horizontal		
1.4MHz	QPSK	H	1430.60	-41.29	Vertical	-13.00	Pass
			2145.90	-47.51	Vertical		
			1430.60	-40.49	Horizontal		
			2145.90	-53.68	Horizontal		
3MHz	QPSK	L	1401.00	-42.78	Vertical	-13.00	Pass
			2101.50	-49.79	Vertical		
			1401.00	-41.56	Horizontal		
			2101.50	-53.90	Horizontal		
3MHz	QPSK	M	1415.00	-42.22	Vertical	-13.00	Pass
			2122.50	-49.77	Vertical		
			1415.00	-42.73	Horizontal		
			2122.50	-54.35	Horizontal		
3MHz	QPSK	H	1429.00	-40.83	Vertical	-13.00	Pass
			2143.50	-48.69	Vertical		
			1429.00	-42.07	Horizontal		
			2143.50	-52.10	Horizontal		

Remark :

1. The emission behavior belongs to narrowband spurious emission.
2. The emission levels of below 1 GHz are very lower than the limit above 10dB and not show in test report.



Band 12 Radiated Spurious Emissions							
Bandwidth	Modulation	Test Channel	Spurious Emission			Limit (dBm)	Result
			Frequency	Level (dBm)	Polarization		
5MHz	QPSK	L	1403.00	-41.81	Vertical	-13.00	Pass
			2104.50	-48.52	Vertical		
			1403.00	-45.73	Horizontal		
			2104.50	-53.53	Horizontal		
5MHz	QPSK	M	1415.00	-42.04	Vertical	-13.00	Pass
			2122.50	-47.91	Vertical		
			1415.00	-42.97	Horizontal		
			2122.50	-53.29	Horizontal		
5MHz	QPSK	H	1427.00	-40.00	Vertical	-13.00	Pass
			2140.50	-48.54	Vertical		
			1427.00	-40.92	Horizontal		
			2140.50	-54.28	Horizontal		
10MHz	QPSK	L	1408.00	-41.09	Vertical	-13.00	Pass
			2112.00	-47.08	Vertical		
			1408.00	-40.03	Horizontal		
			2112.00	-52.63	Horizontal		
10MHz	QPSK	M	1415.00	-40.44	Vertical	-13.00	Pass
			2122.50	-49.15	Vertical		
			1415.00	-40.95	Horizontal		
			2122.50	-53.56	Horizontal		
10MHz	QPSK	H	1422.00	-41.45	Vertical	-13.00	Pass
			2133.00	-47.63	Vertical		
			1422.00	-41.47	Horizontal		
			2133.00	-54.18	Horizontal		

Remark :

1. The emission behavior belongs to narrowband spurious emission.
2. The emission levels of below 1 GHz are very lower than the limit above 10dB and not show in test report.

3.8. Frequency stability

LIMIT

Cellular Band: $\pm 2.5\text{ppm}$ PCS Band: Within the authorized frequency block

TEST CONFIGURATION

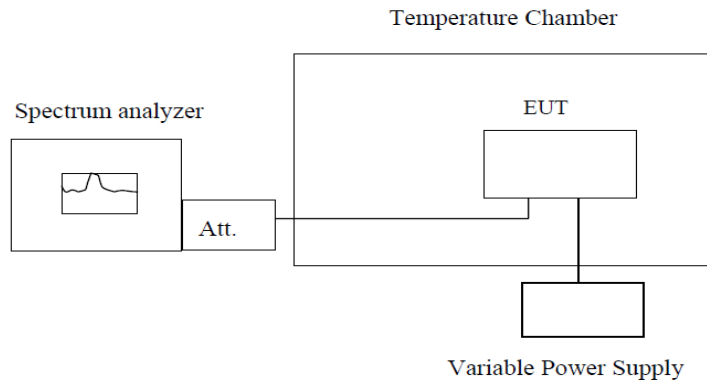

Note : Measurement setup for testing on Antenna connector

TEST PROCEDURE

1. The equipment under test was connected to an external DC power supply and input rated voltage.
2. RF output was connected to a frequency counter or spectrum analyzer via feed through attenuators.
3. The EUT was placed inside the temperature chamber.
4. Set the spectrum analyzer RBW low enough to obtain the desired frequency resolution and measure EUT 25 $^{\circ}\text{C}$ operating frequency as reference frequency.
5. Turn EUT off and set the chamber temperature to -30°C . After the test approximately 30 minutes recorded the frequency.
6. Repeat step measure with 10 $^{\circ}\text{C}$ increased per stage reached.
7. Reduce the input voltage to specified extreme voltage variation ($\pm 15\%$) and endpoint, record the maximum frequency change.

TEST RESULTS

Remark: For this item, all test of Low/Middle/High channel have been test, the report only present the worse case



1. Temperature measurement:

Reference Frequency: Band 2(1.4MHz) Middle channel=18900 channel=1880.00MHz					
Voltage (V)	Temperature (°C)	Frequency error		Limit (ppm)	Result
		Hz	ppm		
3.85	-30	159	0.08	±2.5	Pass
	-20	177	0.09		
	-10	218	0.12		
	0	196	0.10		
	10	153	0.08		
	20	153	0.08		
	30	229	0.12		
	40	167	0.09		
	50	168	0.09		
Reference Frequency: Band 2(3MHz) Middle channel=18900 channel=1880.00MHz					
Voltage (V)	Temperature (°C)	Frequency error		Limit (ppm)	Result
		Hz	ppm		
3.85	-30	232	0.12	±2.5	Pass
	-20	247	0.13		
	-10	194	0.10		
	0	223	0.12		
	10	244	0.13		
	20	250	0.13		
	30	205	0.11		
	40	204	0.11		
	50	220	0.12		



Reference Frequency: Band 2(5MHz) Middle channel=18900 channel=1880.00MHz					
Voltage (V)	Temperature (°C)	Frequency error		Limit (ppm)	Result
		Hz	ppm		
3.85	-30	242	0.13	±2.5	Pass
	-20	341	0.18		
	-10	200	0.11		
	0	194	0.10		
	10	150	0.08		
	20	234	0.12		
	30	192	0.10		
	40	152	0.08		
	50	245	0.13		
Reference Frequency: Band 2(10MHz) Middle channel=18900 channel=1880.00MHz					
Voltage (V)	Temperature (°C)	Frequency error		Limit (ppm)	Result
		Hz	ppm		
3.85	-30	256	0.14	±2.5	Pass
	-20	105	0.06		
	-10	108	0.06		
	0	165	0.09		
	10	208	0.11		
	20	236	0.13		
	30	208	0.11		
	40	153	0.08		
	50	240	0.13		



Reference Frequency: Band 2(15MHz) Middle channel=18900 channel=1880.00MHz					
Voltage (V)	Temperature (°C)	Frequency error		Limit (ppm)	Result
		Hz	ppm		
3.85	-30	145	0.08	±2.5	Pass
	-20	124	0.07		
	-10	181	0.10		
	0	190	0.10		
	10	199	0.11		
	20	296	0.16		
	30	111	0.06		
	40	219	0.12		
	50	128	0.07		
Reference Frequency: Band 2(20MHz) Middle channel=18900 channel=1880.00MHz					
Voltage (V)	Temperature (°C)	Frequency error		Limit (ppm)	Result
		Hz	ppm		
3.85	-30	117	0.06	±2.5	Pass
	-20	176	0.09		
	-10	206	0.11		
	0	295	0.16		
	10	226	0.12		
	20	208	0.11		
	30	119	0.06		
	40	147	0.08		
	50	111	0.06		



Reference Frequency: Band 4(1.4MHz) Middle channel=20175 channel=1732.50MHz					
Voltage (V)	Temperature (°C)	Frequency error		Limit (ppm)	Result
		Hz	ppm		
3.85	-30	175	0.10	±2.5	Pass
	-20	277	0.16		
	-10	125	0.07		
	0	204	0.12		
	10	193	0.11		
	20	151	0.09		
	30	148	0.09		
	40	199	0.11		
	50	161	0.09		
Reference Frequency: Band 4(3MHz) Middle channel=20175 channel=1732.50MHz					
Voltage (V)	Temperature (°C)	Frequency error		Limit (ppm)	Result
		Hz	ppm		
3.85	-30	274	0.16	±2.5	Pass
	-20	204	0.12		
	-10	180	0.10		
	0	148	0.09		
	10	233	0.13		
	20	218	0.13		
	30	106	0.06		
	40	268	0.15		
	50	295	0.17		



Reference Frequency: Band 4(5MHz) Middle channel=20175 channel=1732.50MHz					
Voltage (V)	Temperature (°C)	Frequency error		Limit (ppm)	Result
		Hz	ppm		
3.85	-30	162	0.09	±2.5	Pass
	-20	210	0.12		
	-10	149	0.09		
	0	269	0.16		
	10	261	0.15		
	20	160	0.09		
	30	198	0.11		
	40	176	0.10		
	50	217	0.13		
Reference Frequency: Band 4(10MHz) Middle channel=20175 channel=1732.50MHz					
Voltage (V)	Temperature (°C)	Frequency error		Limit (ppm)	Result
		Hz	ppm		
3.85	-30	117	0.07	±2.5	Pass
	-20	201	0.12		
	-10	275	0.16		
	0	261	0.15		
	10	274	0.16		
	20	105	0.06		
	30	116	0.07		
	40	290	0.17		
	50	231	0.13		



Reference Frequency: Band 4(15MHz) Middle channel=20175 channel=1732.50MHz					
Voltage (V)	Temperature (°C)	Frequency error		Limit (ppm)	Result
		Hz	ppm		
3.85	-30	151	0.09	±2.5	Pass
	-20	157	0.09		
	-10	103	0.06		
	0	179	0.10		
	10	161	0.09		
	20	157	0.09		
	30	144	0.08		
	40	255	0.15		
	50	263	0.15		
Reference Frequency: Band 4(20MHz) Middle channel=20175 channel=1732.50MHz					
Voltage (V)	Temperature (°C)	Frequency error		Limit (ppm)	Result
		Hz	ppm		
3.85	-30	217	0.13	±2.5	Pass
	-20	285	0.16		
	-10	130	0.08		
	0	215	0.12		
	10	215	0.12		
	20	264	0.15		
	30	289	0.17		
	40	185	0.11		
	50	191	0.11		



Reference Frequency: Band 5(1.4MHz) Middle channel=20525 channel=836.50MHz					
Voltage (V)	Temperature (°C)	Frequency error		Limit (ppm)	Result
		Hz	ppm		
3.85	-30	195	0.23	±2.5	Pass
	-20	189	0.23		
	-10	203	0.24		
	0	137	0.16		
	10	257	0.31		
	20	231	0.28		
	30	154	0.18		
	40	283	0.34		
	50	235	0.28		
Reference Frequency: Band 5(3MHz) Middle channel=20525 channel=836.50MHz					
Voltage (V)	Temperature (°C)	Frequency error		Limit (ppm)	Result
		Hz	ppm		
3.85	-30	227	0.27	±2.5	Pass
	-20	146	0.17		
	-10	213	0.25		
	0	212	0.25		
	10	142	0.17		
	20	224	0.27		
	30	196	0.23		
	40	237	0.28		
	50	249	0.30		



Reference Frequency: Band 5(5MHz) Middle channel=20525 channel=836.50MHz					
Voltage (V)	Temperature (°C)	Frequency error		Limit (ppm)	Result
		Hz	ppm		
3.85	-30	141	0.17	±2.5	Pass
	-20	175	0.21		
	-10	221	0.26		
	0	284	0.34		
	10	177	0.21		
	20	153	0.18		
	30	246	0.29		
	40	192	0.23		
	50	269	0.32		
Reference Frequency: Band 5(10MHz) Middle channel=20525 channel=836.50MHz					
Voltage (V)	Temperature (°C)	Frequency error		Limit (ppm)	Result
		Hz	ppm		
3.85	-30	231	0.28	±2.5	Pass
	-20	284	0.34		
	-10	269	0.32		
	0	134	0.16		
	10	128	0.15		
	20	169	0.20		
	30	196	0.23		
	40	198	0.24		
	50	278	0.33		



Reference Frequency: Band 12(1.4MHz) Middle channel=23095 channel=707.5MHz					
Voltage (V)	Temperature (°C)	Frequency error		Limit (ppm)	Result
		Hz	ppm		
3.85	-30	107	0.15	±2.5	Pass
	-20	260	0.37		
	-10	183	0.26		
	0	129	0.18		
	10	262	0.37		
	20	290	0.41		
	30	165	0.23		
	40	174	0.25		
	50	195	0.27		
Reference Frequency: Band 12(3MHz) Middle channel=23095 channel=707.5MHz					
Voltage (V)	Temperature (°C)	Frequency error		Limit (ppm)	Result
		Hz	ppm		
3.85	-30	248	0.35	±2.5	Pass
	-20	100	0.14		
	-10	156	0.22		
	0	217	0.31		
	10	210	0.30		
	20	281	0.40		
	30	105	0.15		
	40	282	0.40		
	50	152	0.21		



Reference Frequency: Band 12(5MHz) Middle channel=23095 channel=707.5MHz					
Voltage (V)	Temperature (°C)	Frequency error		Limit (ppm)	Result
		Hz	ppm		
3.85	-30	126	0.18	±2.5	Pass
	-20	288	0.41		
	-10	184	0.26		
	0	164	0.23		
	10	160	0.23		
	20	117	0.17		
	30	201	0.28		
	40	182	0.26		
	50	196	0.28		
Reference Frequency: Band 12(10MHz) Middle channel=23095 channel=707.5MHz					
Voltage (V)	Temperature (°C)	Frequency error		Limit (ppm)	Result
		Hz	ppm		
3.85	-30	241	0.34	±2.5	Pass
	-20	159	0.22		
	-10	264	0.37		
	0	153	0.22		
	10	180	0.25		
	20	110	0.16		
	30	125	0.18		
	40	227	0.32		
	50	275	0.39		



2. Voltage measurement:

Reference Frequency: Band 2(1.4MHz) Middle channel=18900 channel=1880.00MHz					
Temperature (°C)	Voltage (V)	Frequency error		Limit (ppm)	Result
		Hz	ppm		
25	4.42	188	0.10	±2.5	Pass
	3.85	240	0.13		
	3.27	297	0.16		
Reference Frequency: Band 2(3MHz) Middle channel=18900 channel=1880.00MHz					
Temperature (°C)	Voltage (V)	Frequency error		Limit (ppm)	Result
		Hz	ppm		
25	4.42	209	0.11	±2.5	Pass
	3.85	253	0.13		
	3.27	271	0.14		
Reference Frequency: Band 2(5MHz) Middle channel=18900 channel=1880.00MHz					
Temperature (°C)	Voltage (V)	Frequency error		Limit (ppm)	Result
		Hz	ppm		
25	4.42	253	0.13	±2.5	Pass
	3.85	155	0.08		
	3.27	251	0.13		
Reference Frequency: Band 2(10MHz) Middle channel=18900 channel=1880.00MHz					
Temperature (°C)	Voltage (V)	Frequency error		Limit (ppm)	Result
		Hz	ppm		
25	4.42	279	0.15	±2.5	Pass
	3.85	146	0.08		
	3.27	145	0.08		
Reference Frequency: Band 2(15MHz) Middle channel=18900 channel=1880.00MHz					
Temperature (°C)	Voltage (V)	Frequency error		Limit (ppm)	Result
		Hz	ppm		
25	4.42	212	0.11	±2.5	Pass
	3.85	139	0.07		
	3.27	334	0.18		
Reference Frequency: Band 2(20MHz) Middle channel=18900 channel=1880.00MHz					
Temperature (°C)	Voltage (V)	Frequency error		Limit (ppm)	Result
		Hz	ppm		
25	4.42	158	0.08	±2.5	Pass
	3.85	153	0.08		
	3.27	253	0.13		



Reference Frequency: Band 4(1.4MHz) Middle channel=20175 channel=1732.50MHz					
Temperature (°C)	Voltage (V)	Frequency error		Limit (ppm)	Result
		Hz	ppm		
25	4.42	235	0.14	±2.5	Pass
	3.85	169	0.10		
	3.27	121	0.07		
Reference Frequency: Band 4(3MHz) Middle channel=20175 channel=1732.50MHz					
Temperature (°C)	Voltage (V)	Frequency error		Limit (ppm)	Result
		Hz	ppm		
25	4.42	291	0.17	±2.5	Pass
	3.85	286	0.17		
	3.27	195	0.11		
Reference Frequency: Band 4(5MHz) Middle channel=20175 channel=1732.50MHz					
Temperature (°C)	Voltage (V)	Frequency error		Limit (ppm)	Result
		Hz	ppm		
25	4.42	133	0.08	±2.5	Pass
	3.85	120	0.07		
	3.27	105	0.06		
Reference Frequency: Band 4(10MHz) Middle channel=20175 channel=1732.50MHz					
Temperature (°C)	Voltage (V)	Frequency error		Limit (ppm)	Result
		Hz	ppm		
25	4.42	270	0.16	±2.5	Pass
	3.85	151	0.09		
	3.27	229	0.13		
Reference Frequency: Band 4(15MHz) Middle channel=20175 channel=1732.50MHz					
Temperature (°C)	Voltage (V)	Frequency error		Limit (ppm)	Result
		Hz	ppm		
25	4.42	294	0.17	±2.5	Pass
	3.85	286	0.16		
	3.27	162	0.09		
Reference Frequency: Band 4(20MHz) Middle channel=20175 channel=1732.50MHz					
Temperature (°C)	Voltage (V)	Frequency error		Limit (ppm)	Result
		Hz	ppm		
25	4.42	125	0.07	±2.5	Pass
	3.85	255	0.15		
	3.27	149	0.09		



Reference Frequency: Band 5(1.4MHz) Middle channel=20525 channel=836.50MHz					
Temperature (°C)	Voltage (V)	Frequency error		Limit (ppm)	Result
		Hz	ppm		
25	4.42	130	0.16	±2.5	Pass
	3.85	118	0.14		
	3.27	211	0.25		
Reference Frequency: Band 5(3MHz) Middle channel=20525 channel=836.50MHz					
Temperature (°C)	Voltage (V)	Frequency error		Limit (ppm)	Result
		Hz	ppm		
25	4.42	212	0.25	±2.5	Pass
	3.85	163	0.19		
	3.27	153	0.18		
Reference Frequency: Band 5(5MHz) Middle channel=20525 channel=836.50MHz					
Temperature (°C)	Voltage (V)	Frequency error		Limit (ppm)	Result
		Hz	ppm		
25	4.42	182	0.22	±2.5	Pass
	3.85	299	0.36		
	3.27	131	0.16		
Reference Frequency: Band 5(10MHz) Middle channel=20525 channel=836.50MHz					
Temperature (°C)	Voltage (V)	Frequency error		Limit (ppm)	Result
		Hz	ppm		
25	4.42	313	0.37	±2.5	Pass
	3.85	348	0.42		
	3.27	321	0.38		



Reference Frequency: Band 12(1.4MHz) Middle channel=23095 channel=707.5MHz					
Temperature (°C)	Voltage (V)	Frequency error		Limit (ppm)	Result
		Hz	ppm		
25	4.42	158	0.22	±2.5	Pass
	3.85	128	0.18		
	3.27	231	0.33		
Reference Frequency: Band 12(3MHz) Middle channel=23095 channel=707.5MHz					
Temperature (°C)	Voltage (V)	Frequency error		Limit (ppm)	Result
		Hz	ppm		
25	4.42	238	0.34	±2.5	Pass
	3.85	248	0.35		
	3.27	151	0.21		
Reference Frequency: Band 12(5MHz) Middle channel=23095 channel=707.5MHz					
Temperature (°C)	Voltage (V)	Frequency error		Limit (ppm)	Result
		Hz	ppm		
25	4.42	131	0.19	±2.5	Pass
	3.85	241	0.34		
	3.27	175	0.25		
Reference Frequency: Band 12(10MHz) Middle channel=23095 channel=707.5MHz					
Temperature (°C)	Voltage (V)	Frequency error		Limit (ppm)	Result
		Hz	ppm		
25	4.42	288	0.41	±2.5	Pass
	3.85	300	0.42		
	3.27	122	0.17		



4. EUT TEST PHOTOS

Reference to the document No.: Test Photographs 2.



5. PHOTOGRAPHS OF EUT CONSTRUCTIONAL

Reference to the document No.: External Photographs and Internal Photographs.

*****THE END*****