

## FCC Test Report

### (PART 22)

**Report No.:** RFBGSN-WTW-P20080589

**FCC ID:** NKS-PA1

**Test Model:** Trimble Gateway-PA1

**Received Date:** Aug. 29, 2020

**Test Date:** Sep. 24, 2020 ~ Oct. 19, 2020

**Issued Date:** Oct. 28, 2020

**Applicant:** PeopleNet Communications Corporation

**Address:** 4400 Baker Road, Minnetonka Minnesota 55343-8684 United States

**Issued By:** Bureau Veritas Consumer Products Services (H.K.) Ltd., Taoyuan Branch  
Lin Kou Laboratories

**Lab Address:** No. 47-2, 14th Ling, Chia Pau Vil., Lin Kou Dist., New Taipei City, Taiwan

**Test Location:** No.19, Hwa Ya 2nd Rd., Wen Hwa Vil., Kwei Shan Dist., Taoyuan City  
33383, Taiwan

**FCC Registration /  
Designation Number:** 788550 / TW0003



This report is for your exclusive use. Any copying or replication of this report to or for any other person or entity, or use of our name or trademark, is permitted only with our prior written permission. This report sets forth our findings solely with respect to the test samples identified herein. The results set forth in this report are not indicative or representative of the quality or characteristics of the lot from which a test sample was taken or any similar or identical product unless specifically and expressly noted. Our report includes all of the tests requested by you and the results thereof based upon the information that you provided to us. You have 60 days from date of issuance of this report to notify us of any material error or omission caused by our negligence, provided, however, that such notice shall be in writing and shall specifically address the issue you wish to raise. A failure to raise such issue within the prescribed time shall constitute your unqualified acceptance of the completeness of this report, the tests conducted and the correctness of the report contents. Unless specifically mentioned, the uncertainty of measurement has been explicitly taken into account to declare the compliance or non-compliance to the specification.

## Table of Contents

<b>Release Control Record</b> .....	<b>4</b>
<b>1 Certificate of Conformity</b> .....	<b>5</b>
<b>2 Summary of Test Results</b> .....	<b>6</b>
2.1 Measurement Uncertainty .....	6
2.2 Test Site and Instruments .....	7
<b>3 General Information</b> .....	<b>8</b>
3.1 General Description of EUT .....	8
3.2 Configuration of System under Test .....	9
3.2.1 Description of Support Units .....	9
3.3 Test Mode Applicability and Tested Channel Detail .....	10
3.4 EUT Operating Conditions .....	11
3.5 General Description of Applied Standards and references .....	11
<b>4 Test Types and Results</b> .....	<b>12</b>
4.1 Output Power Measurement .....	12
4.1.1 Limits of Output Power Measurement .....	12
4.1.2 Test Procedures .....	12
4.1.3 Test Setup .....	13
4.1.4 Test Results .....	14
4.2 Modulation Characteristics Measurement .....	15
4.2.1 Limits of Modulation Characteristics .....	15
4.2.2 Test Setup .....	15
4.2.3 Test Procedure .....	15
4.2.4 Test Results .....	15
4.3 Frequency Stability Measurement .....	16
4.3.1 Limits of Frequency Stability Measurement .....	16
4.3.2 Test Procedure .....	16
4.3.3 Test Setup .....	16
4.3.4 Test Results .....	17
4.4 Occupied Bandwidth Measurement .....	18
4.4.1 Test Procedure .....	18
4.4.2 Test Setup .....	18
4.4.3 Test Result .....	18
4.5 Band Edge Measurement .....	19
4.5.1 Limits of Band Edge Measurement .....	19
4.5.2 Test Setup .....	19
4.5.3 Test Procedures .....	19
4.5.4 Test Results .....	19
4.6 Peak to Average Ratio .....	20
4.6.1 Limits of Peak to Average Ratio Measurement .....	20
4.6.2 Test Setup .....	20
4.6.3 Test Procedures .....	20
4.6.4 Test Results .....	20
4.7 Conducted Spurious Emissions .....	21
4.7.1 Limits of Conducted Spurious Emissions Measurement .....	21
4.7.2 Test Setup .....	21
4.7.3 Test Procedure .....	21
4.7.4 Test Results .....	22
4.8 Radiated Emission Measurement .....	23
4.8.1 Limits of Radiated Emission Measurement .....	23
4.8.2 Test Procedure .....	23
4.8.3 Deviation from Test Standard .....	23
4.8.4 Test Setup .....	24
4.8.5 Test Results .....	25

<b>5 Pictures of Test Arrangements.....</b>	<b>37</b>
<b>Appendix – Information of the Testing Laboratories .....</b>	<b>38</b>



### Release Control Record

Issue No.	Description	Date Issued
RFBGSN-WTW-P20080589	Original Release	Oct. 28, 2020

## 1 Certificate of Conformity

**Product:** Trimble Gateway NA

**Brand:** Trimble

**Test Model:** Trimble Gateway-PA1

**Sample Status:** Engineering Sample

**Applicant:** PeopleNet Communications Corporation

**Test Date:** Sep. 24, 2020 ~ Oct. 19, 2020

**Standards:** FCC Part 22, Subpart H

The above equipment has been tested by **Bureau Veritas Consumer Products Services (H.K.) Ltd., Taoyuan Branch**, and found compliance with the requirement of the above standards. The test record, data evaluation & Equipment Under Test (EUT) configurations represented herein are true and accurate accounts of the measurements of the sample's RF characteristics under the conditions specified in this report.

**Prepared by :** , **Date:** Oct. 28, 2020  
Vera Huang / Specialist

**Approved by :** , **Date:** Oct. 28, 2020  
Dylan Chiou / Senior Project Engineer

## 2 Summary of Test Results

Applied Standard: FCC Part 22 & Part 2			
FCC Clause	Test Item	Result	Remarks
2.1046 22.913 (a)	Effective Radiated Power	Pass	Meet the requirement of limit.
2.1047	Modulation Characteristics	Pass	Meet the requirement.
22.913 (d)	Peak to Average Ratio	Pass	Meet the requirement of limit.
2.1055 22.355	Frequency Stability	Pass	Meet the requirement of limit.
2.1049	Occupied Bandwidth	Pass	Meet the requirement of limit.
22.917	Band Edge Measurements	Pass	Meet the requirement of limit.
2.1051 22.917	Conducted Spurious Emissions	Pass	Meet the requirement of limit.
2.1053 22.917	Radiated Spurious Emissions	Pass	Meet the requirement of limit. Minimum passing margin is -23.73 dB at 44.55 MHz.

Note: Determining compliance based on the results of the compliance measurement, not taking into account measurement instrumentation uncertainty.

### 2.1 Measurement Uncertainty

Where relevant, the following measurement uncertainty levels have been estimated for tests performed on the EUT as specified in CISPR 16-4-2:

Measurement	Frequency	Expanded Uncertainty (k=2) ( $\pm$ )
Radiated Emissions up to 1 GHz	9 kHz ~ 30 MHz	3.04 dB
	30 MHz ~ 200 MHz	2.93 dB
	200 MHz ~ 1000 MHz	2.95 dB
Radiated Emissions above 1 GHz	1 GHz ~ 18 GHz	2.26 dB
	18 GHz ~ 40 GHz	1.94 dB

## 2.2 Test Site and Instruments

Description & Manufacturer	Model No.	Serial No.	Date of Calibration	Due Date of Calibration
Test Receiver Agilent	N9038A	MY51210203	Mar. 18, 2020	Mar. 17, 2021
Spectrum Analyzer Agilent	N9010A	MY52220314	Dec. 12, 2019	Dec. 11, 2020
Spectrum Analyzer ROHDE & SCHWARZ	FSU43	101261	Apr. 16, 2020	Apr. 15, 2021
HORN Antenna SCHWARZBECK	BBHA 9120D	9120D-969	Nov. 24, 2019	Nov. 23, 2020
BILOG Antenna SCHWARZBECK	VULB 9168	9168-472	Nov. 08, 2019	Nov. 07, 2020
Fixed Attenuator WOKEN	MDCS18N-10	MDCS18N-10-01	Apr. 14, 2020	Apr. 13, 2021
BILOG Antenna SCHWARZBECK	VULB 9168	9168-160	Nov. 07, 2019	Nov. 06, 2020
MXG Vector signal generator Agilent	N5182B	MY53050430	Oct. 25, 2019	Oct. 24, 2020
Preamplifier EMCI	EMC001340	980201	Oct. 14, 2019 Oct. 21, 2020	Oct. 13, 2020 Oct. 20, 2021
Preamplifier EMCI	EMC 012645	980115	Oct. 08, 2019 Oct. 07, 2020	Oct. 07, 2020 Oct. 06, 2021
Preamplifier EMCI	EMC 330H	980112	Oct. 08, 2019 Oct. 07, 2020	Oct. 07, 2020 Oct. 06, 2021
RF Coaxial Cable EMCI	EMC104-SM-SM-8000	180409	Jan. 18, 2020	Jan. 17, 2021
RF Coaxial Cable HUBER+SUHNNER	SUCOFLEX 104	EMC104-SM-SM-1000(140807)	Oct. 08, 2019 Oct. 07, 2020	Oct. 07, 2020 Oct. 06, 2021
RF Coaxial Cable WOKEN	8D-FB	Cable-Ch10-01	Oct. 08, 2019 Oct. 07, 2020	Oct. 07, 2020 Oct. 06, 2021
Boresight Antenna Fixture	FBA-01	FBA-SIP01	NA	NA
Software BV ADT	E3 6.120103	NA	NA	NA
Antenna Tower MF	MFA-440H	NA	NA	NA
Turn Table MF	MFT-201SS	NA	NA	NA
Antenna Tower & Turn Table Controller MF	MF-7802	NA	NA	NA
Communications Tester- Wireless Agilent	8960 Series 10	MY53201073	Jul. 01, 2019	Jun. 30, 2021
Radio Communication Analyzer Anritsu	MT8821C	6201462755	Feb. 13, 2020	Feb. 12, 2021
Temperature & Humidity Chamber	GTH-120-40-CP-AR	MAA1306-019	Sep. 09, 2020	Sep. 08, 2021
DC Power Supply Topward	33010D	807748	NA	NA

Note: 1. The calibration interval of the above test instruments is 12 / 24 months and the calibrations are traceable to NML/ROC and NIST/USA.

2. The test was performed in HwaYa Chamber 10.

### 3 General Information

#### 3.1 General Description of EUT

<b>Product</b>	Trimble Gateway NA		
<b>Brand</b>	Trimble		
<b>Test Model</b>	Trimble Gateway-PA1		
<b>Status of EUT</b>	Engineering Sample		
<b>Power Supply Rating</b>	12 Vdc (adapter)		
<b>Modulation Type</b>	WCDMA	QPSK	
<b>Frequency Range</b>	WCDMA	826.4 ~ 846.6 MHz	
<b>Max. ERP Power</b>	WCDMA	Mode A	148.59 mW
		Mode B	157.04 mW
<b>Emission Designator</b>	WCDMA	4M15F9W	
<b>Antenna Type</b>	Refer to Note as below		
<b>Accessory Device</b>	N/A		
<b>Data Cable Supplied</b>	N/A		

Note:

1. The information of module collocated in this EUT is listed as below.

Product	Brand	Model
BT/WLAN Module	msi	BM25
WWAN Module	Quectel	EC25-A
AH Module	silex	SX-NEWAH

2. The antenna information is listed as below.

Ant.	Brand	Model	Antenna Type	Antenna Gain (dBi)	Remark
1	TAOGLAS	PCS.06.A	SMD Antenna	0.53	Internal, Main Antenna
2	TAOGLAS	PCS.06.B	SMD Antenna	0.75	Internal, Aux. Antenna
3	TAOGLAS	MA240.LBI.001	Adhesive Mount Combination Antenna	0.94	External, Main Antenna
4	TAOGLAS	MA240.LBI.001	Adhesive Mount Combination Antenna	1	External, Aux. Antenna

3. The above Antenna information is declared by manufacturer and for more detailed features description, please refer to the manufacturer's specifications, the laboratory shall not be held responsible.

4. The above EUT information is declared by manufacturer and for more detailed features description, please refers to the manufacturer's specifications or user's manual.



### 3.2 Configuration of System under Test

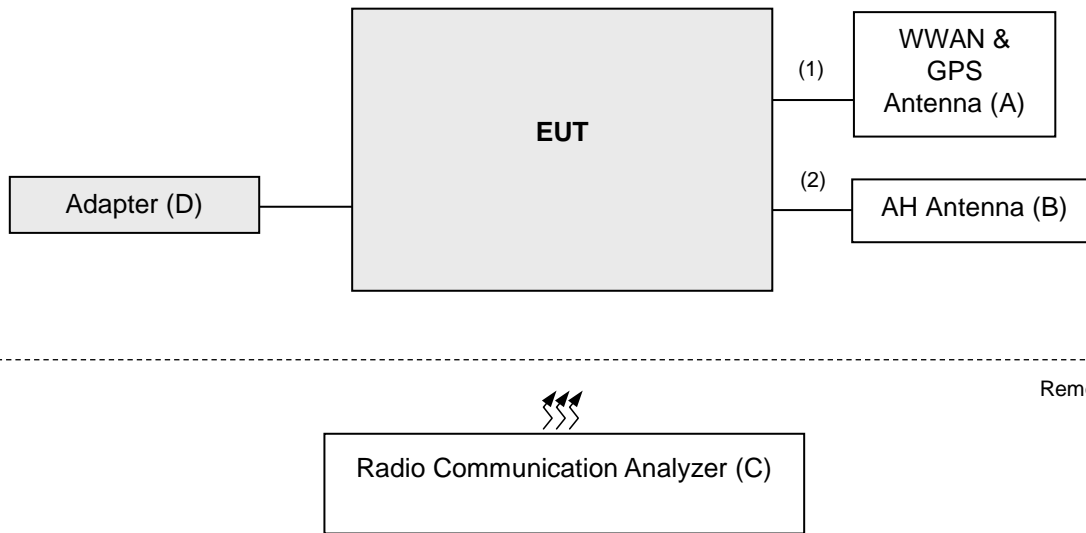

#### 3.2.1 Description of Support Units

The EUT has been tested as an independent unit together with other necessary accessories or support units. The following support units or accessories were used to form a representative test configuration during the tests.

ID	Product	Brand	Model No.	Serial No.	FCC ID	Remarks
A	WWAN & GPS Antenna	TAOGLAS	MA240.LBI.001	NA	NA	Provided by client
B	AH Antenna	TAOGLAS	IS.05.B.301111	NA	NA	Provided by client
C	Radio Communication Analyzer	Anritsu	MT8821C	6201462755	NA	--
D	Adapter	TPT	PMW120300W8	NA	NA	Provided by client AC Input: 100-240V~, 50-60Hz, 1.1A MAX DC Output: 12V, 3.0A

Note:

1. All power cords of the above support units are non-shielded (1.8m).
2. Item C acted as a communication partner to transfer data.

ID	Descriptions	Qty.	Length (m)	Shielding (Yes/No)	Cores (Qty.)	Remarks
1.	RF Cable	3	3	N	0	-
2.	RF Cable	1	3	N	0	-

### 3.3 Test Mode Applicability and Tested Channel Detail

Pre-Scan has been conducted to determine the worst-case mode from all possible combinations between available modulations, data rates, XYZ axis, and antenna ports.

The worst case was found when positioned as the table below. Following channel(s) was (were) selected for the final test as listed below:

EUT Configure Mode	Description	ERP	Radiated Emission
A	EUT + Antenna 1 & 2	Y-plane	Y-axis
B	EUT + Antenna 3 & 4	X-plane	X-axis

#### WCDMA

EUT Configure Mode	Test Item	Available Channel	Tested Channel	Mode
A, B	ERP	4132 to 4233	4132, 4182, 4233	WCDMA
-	Modulation Characteristics	4132 to 4233	4182	WCDMA
-	Frequency Stability	4132 to 4233	4132, 4233	WCDMA
-	Occupied Bandwidth	4132 to 4233	4132, 4182, 4233	WCDMA
-	Band Edge	4132 to 4233	4132, 4233	WCDMA
-	Peak to Average Ratio	4132 to 4233	4132, 4182, 4233	WCDMA
-	Conducted Emission	4132 to 4233	4132, 4182, 4233	WCDMA
A, B	Radiated Emission	4132 to 4233	4132, 4182, 4233	WCDMA

Note:

1. This device was tested under all modulations. The worst case of conducted output power was found in WCDMA modulation. Therefore, all test items were performed under WCDMA mode only.
2. For radiated emissions below 1 GHz, select the worst radiated emission channel (above 1GHz) for final testing.

#### Test Condition:

Test Item	Environmental Conditions	Input Power	Tested By
ERP	25 deg. C, 65 % RH	12 Vdc	Cyril Chen / Tim Chen
Modulation Characteristics	25 deg. C, 65 % RH	12 Vdc	Getaz Yang
Frequency Stability	25 deg. C, 65 % RH	12 Vdc	Getaz Yang
Occupied Bandwidth	25 deg. C, 65 % RH	12 Vdc	Getaz Yang
Band Edge	25 deg. C, 65 % RH	12 Vdc	Getaz Yang
Peak to Average Ratio	25 deg. C, 65 % RH	12 Vdc	Getaz Yang
Conducted Emission	25 deg. C, 65 % RH	12 Vdc	Getaz Yang
Radiated Emission	25 deg. C, 65 % RH	120 Vac, 60 Hz	Cyril Chen / Tim Chen

### **3.4 EUT Operating Conditions**

The EUT makes a call to the communication simulator. The communication simulator station system controlled a EUT to export maximum output power under transmission mode and specific channel frequency.

### **3.5 General Description of Applied Standards and references**

The EUT is a RF Product. According to the specifications of the manufacturer, it must comply with the requirements of the following standards and references:

**Test Standard:**

**FCC 47 CFR Part 2**

**FCC 47 CFR Part 22**

**ANSI 63.26-2015**

**Note:** All test items have been performed and recorded as per the above standards.

**References Test Guidance:**

**KDB 971168 D01 Power Meas License Digital Systems v03r01**

**ANSI/TIA/EIA-603-E 2016**

**Note:** All test items have been performed as a reference to the above KDB test guidance.

## 4 Test Types and Results

### 4.1 Output Power Measurement

#### 4.1.1 Limits of Output Power Measurement

Mobile / Portable station are limited to 7 watts e.r.p.

#### 4.1.2 Test Procedures

##### **EIRP / ERP Measurement:**

- a. All measurements were done at low, middle and high operational frequency range. RBW is 5 MHz for WCDMA, and VBW  $\geq 3 \times$  RBW.
- b. Substitution method is used for E.I.R.P measurement. In the semi-anechoic chamber, EUT placed on the 0.8 m (below or equal 1 GHz) and/or 1.5 m (above 1 GHz) height of Turn Table, rotated the table around 360 degrees to search the maximum radiation power and receiver antenna shall be rotated vertical and horizontal polarization and moved height from 1 m to 4 m to find the maximum polar radiated power. The "Read Value" is the spectrum reading the maximum power value.
- c. EIRP = Output power level of S.G – TX cable loss + Antenna gain of substitution horn. E.R.P power can be calculated form E.I.R.P power by subtracting the gain of dipole, E.R.P power = E.I.R.P power - 2.15 dB.

##### **Conducted Power Measurement:**

The EUT was set up for the maximum power with WCDMA link data modulation and link up with simulator. Set the EUT to transmit under low, middle and high channel and record the power level shown on simulator.

4.1.3 Test Setup

**EIRP / ERP Measurement:**

**<Radiated Emission below or equal 1 GHz>**

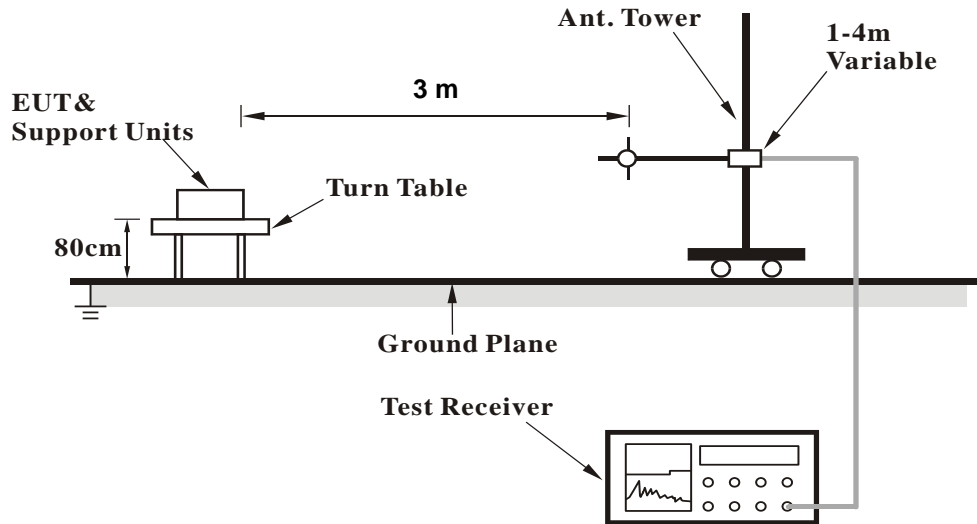

**<Radiated Emission above 1 GHz>**

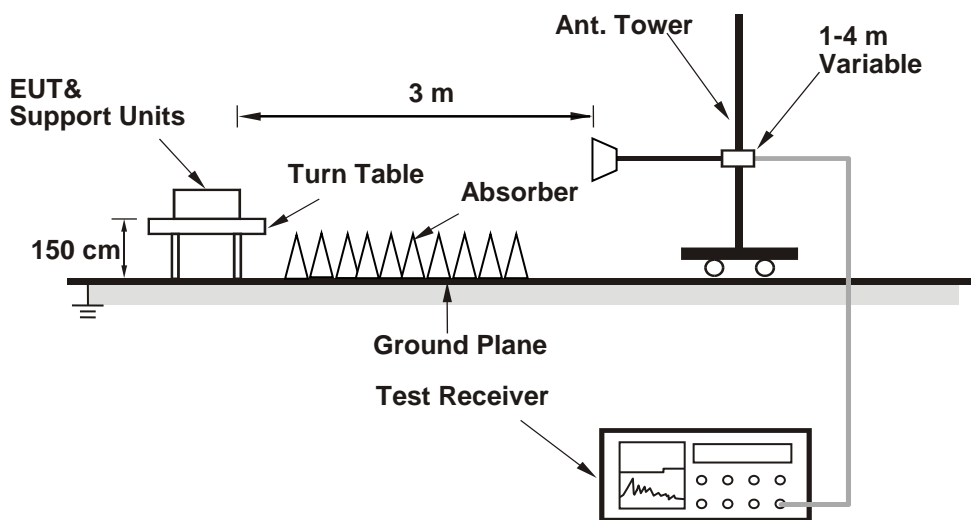

For the actual test configuration, please refer to the attached file (Test Setup Photo).

**Conducted Power Measurement:**



#### 4.1.4 Test Results

##### Conducted Output Power (dBm)

Band	WCDMA V		
Channel	4132	4182	4233
Frequency (MHz)	826.4	836.4	846.6
RMC 12.2K	22.78	23.11	22.98
HSDPA Subtest-1	21.88	22.28	22.08
HSDPA Subtest-2	21.84	22.21	22.01
HSDPA Subtest-3	21.81	22.18	21.94
HSDPA Subtest-4	21.75	22.14	21.91
HSUPA Subtest-1	21.82	22.21	22.05
HSUPA Subtest-2	19.89	20.31	20.07
HSUPA Subtest-3	20.91	21.34	21.06
HSUPA Subtest-4	19.85	20.28	20.05
HSUPA Subtest-5	21.80	22.18	22.01

##### Mode A

##### ERP Power (dBm)

WCDMA							
Plane	Channel	Frequency (MHz)	Reading (dBm)	Correction Factor (dB)	ERP (dBm)	ERP (mW)	Polarization (H/V)
Y	4132	826.4	-18.57	32.62	14.05	25.41	H
	4182	836.4	-18.40	32.52	14.12	25.82	
	4233	846.6	-18.46	32.65	14.19	26.24	
	4132	826.4	-11.16	32.76	21.60	144.54	V
	4182	836.4	-10.75	32.39	21.64	145.88	
	4233	846.6	-10.82	32.54	21.72	148.59	

Note: ERP (dBm) = Reading (dBm) + Correction Factor (dB)

##### Mode B

##### ERP Power (dBm)

WCDMA							
Plane	Channel	Frequency (MHz)	Reading (dBm)	Correction Factor (dB)	ERP (dBm)	ERP (mW)	Polarization (H/V)
X	4132	826.4	-10.71	32.62	21.91	155.24	H
	4182	836.4	-10.56	32.52	21.96	157.04	
	4233	846.6	-10.78	32.65	21.87	153.82	
	4132	826.4	-18.40	32.76	14.36	27.29	V
	4182	836.4	-17.94	32.39	14.45	27.86	
	4233	846.6	-18.14	32.54	14.40	27.54	

Note: ERP (dBm) = Reading (dBm) + Correction Factor (dB)

## 4.2 Modulation Characteristics Measurement

### 4.2.1 Limits of Modulation Characteristics

N/A

### 4.2.2 Test Setup



### 4.2.3 Test Procedure

Connect the EUT to Communication Simulator via the antenna connector. The frequency band is set as EUT supported Modulation and Channels, the EUT output is matched with 50 ohm load, the waveform quality and constellation of the EUT was tested.

### 4.2.4 Test Results

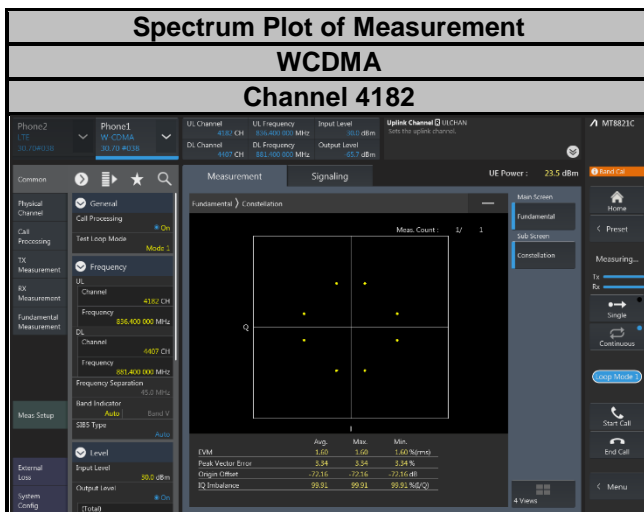

### 4.3 Frequency Stability Measurement

#### 4.3.1 Limits of Frequency Stability Measurement

1.5 ppm is for base and fixed station. 2.5 ppm is for mobile station.

#### 4.3.2 Test Procedure

- a. Device is placed at the oven room. The oven room could control the temperatures and humidity. Power warm up is at least 15 min and power applied should perform before recording frequency error.
- b. EUT is connected the external power supply to control the DC input power. The test voltage range is from minimum to maximum working voltage. Each step shall be record the frequency error rate.
- c. The temperature range step is 10 degrees in this test items. All temperature levels shall be hold the  $\pm 0.5$  °C during the measurement testing. The each temperature step shall be at least 0.5 hours, consider the EUT could be test under the stability condition.

**NOTE:** The frequency error was recorded frequency error from the communication simulator.

#### 4.3.3 Test Setup

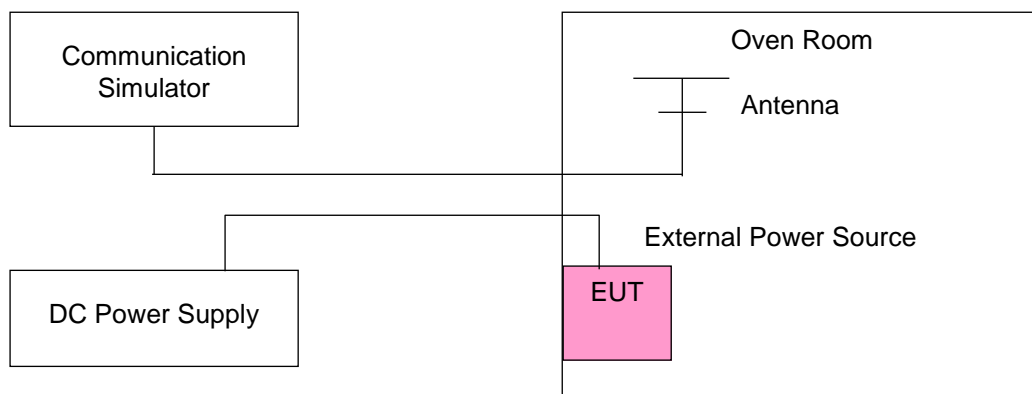



#### 4.3.4 Test Results

##### Frequency Error vs. Voltage

Voltage (Volts)	WCDMA				Limit (ppm)
	Low Channel		High Channel		
	Frequency (MHz)	Frequency Error (ppm)	Frequency (MHz)	Frequency Error (ppm)	
12	826.400001	0.001	846.600002	0.002	2.5
10.2	826.400002	0.002	846.600004	0.004	2.5
13.8	826.400002	0.002	846.600003	0.003	2.5

**Note:** The applicant defined the normal working voltage is from 10.2 Vdc to 13.8 Vdc.

##### Frequency Error vs. Temperature

Temp. (°C)	WCDMA				Limit (ppm)
	Low Channel		High Channel		
	Frequency (MHz)	Frequency Error (ppm)	Frequency (MHz)	Frequency Error (ppm)	
-40	826.400004	0.004	846.600003	0.004	2.5
-30	826.400002	0.002	846.600001	0.001	2.5
-20	826.400003	0.003	846.600003	0.003	2.5
-10	826.400003	0.004	846.600002	0.002	2.5
0	826.399996	-0.005	846.599996	-0.004	2.5
10	826.399998	-0.002	846.599997	-0.003	2.5
20	826.399997	-0.004	846.599999	-0.002	2.5
30	826.399997	-0.003	846.599996	-0.004	2.5
40	826.399997	-0.004	846.599998	-0.003	2.5
50	826.399997	-0.003	846.599999	-0.002	2.5
60	826.399996	-0.004	846.599998	-0.002	2.5
70	826.399998	-0.003	846.599997	-0.004	2.5
80	826.399997	-0.003	846.599997	-0.004	2.5
85	826.399996	-0.004	846.599999	-0.001	2.5

**Note:**

1. The applicant declared that the normal operating temperature of the EUT is from -40°C to 85°C.
2. The EUT would shut down automatically as below -40°C.

#### 4.4 Occupied Bandwidth Measurement

##### 4.4.1 Test Procedure

The EUT makes a call to the communication simulator. All measurements were done at low, middle and high operational frequency range. The communication simulator station system controlled a EUT to export maximum output power under transmission mode and specific channel frequency. Use OBW measurement function of Spectrum analyzer to measure 99 % occupied bandwidth.

##### 4.4.2 Test Setup

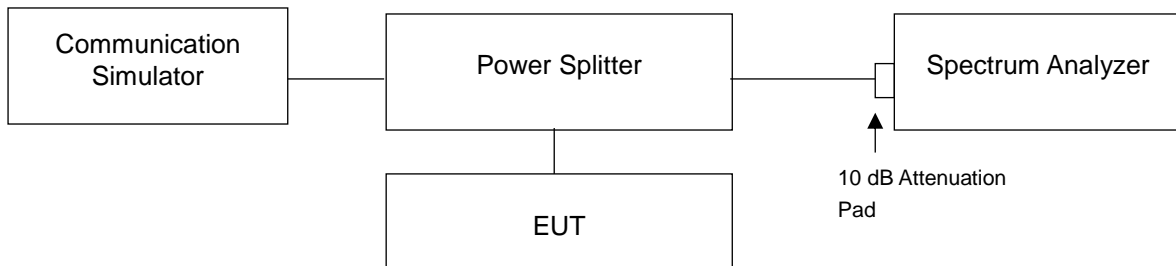

##### 4.4.3 Test Result

WCDMA			
Channel	Frequency (MHz)	99 % Occupied Bandwidth (MHz)	26 dB Bandwidth (MHz)
4132	826.4	4.1410	4.728
4182	836.4	4.1391	4.703
4233	846.6	4.1521	4.725

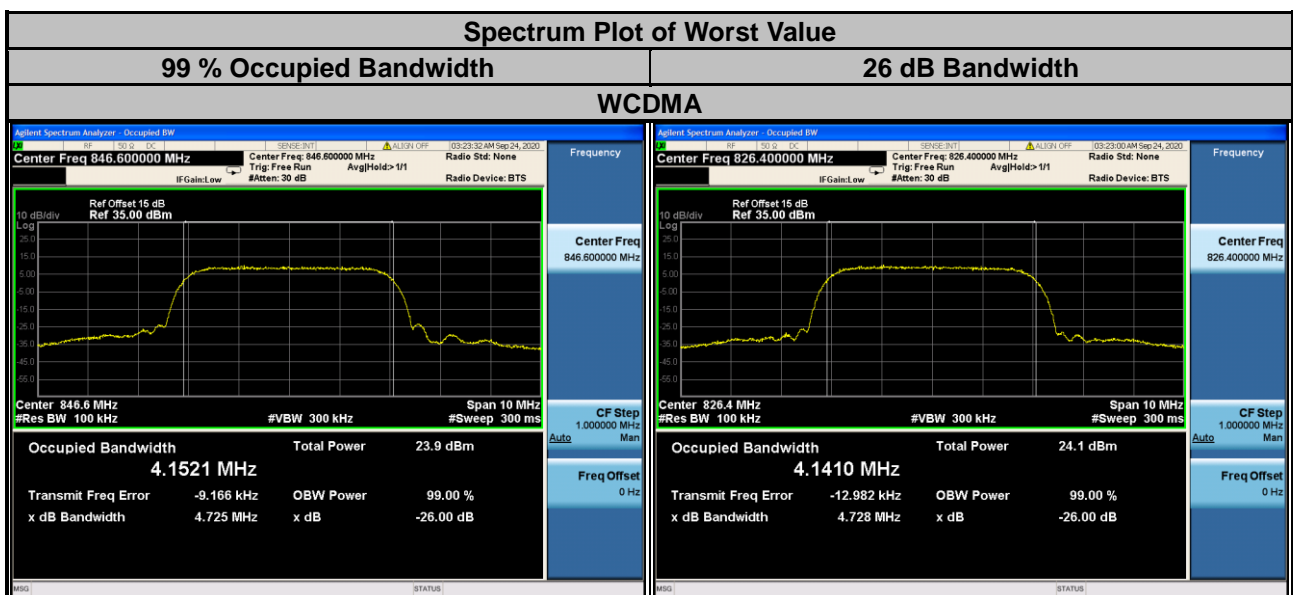

## 4.5 Band Edge Measurement

### 4.5.1 Limits of Band Edge Measurement

Power of any emission outside of the authorized operating frequency ranges must be attenuated below the transmitting power (P) by a factor of at least  $43 + 10 \log(P)$  dB. In the 1 MHz bands immediately outside and adjacent to the frequency block a resolution bandwidth of at least one percent of the emission bandwidth of the fundamental emission of the transmitter may be employed.

### 4.5.2 Test Setup

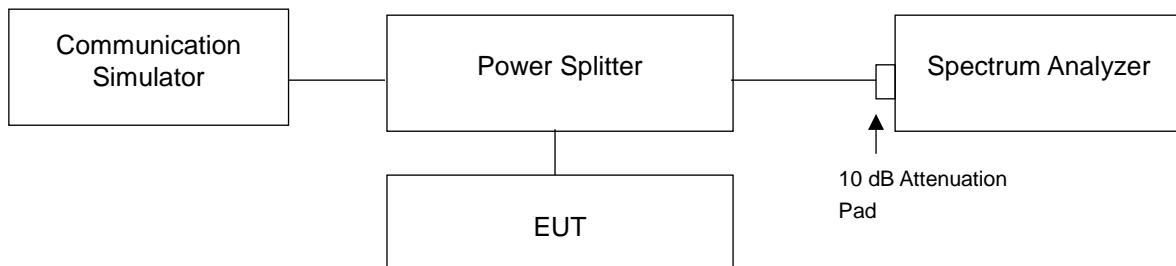

### 4.5.3 Test Procedures

- All measurements were done at low and high operational frequency range.
- The center frequency of spectrum is the band edge frequency and span is 5 MHz. RB of the spectrum is 51 kHz and VB of the spectrum is 160 kHz (WCDMA).
- Record the max trace plot into the test report.

### 4.5.4 Test Results

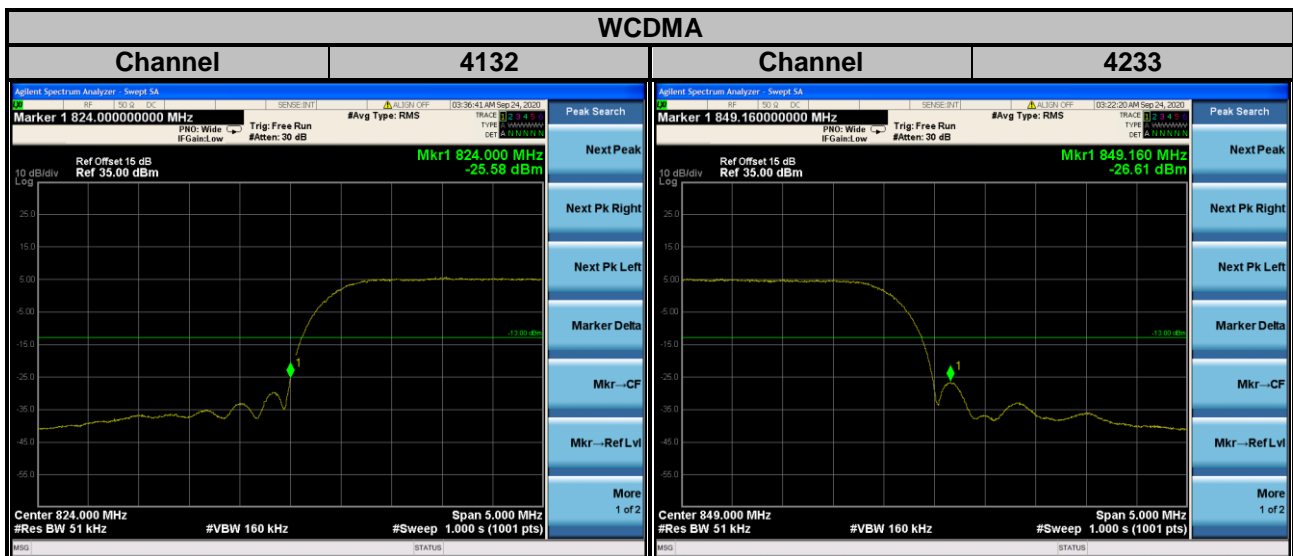

## 4.6 Peak to Average Ratio

### 4.6.1 Limits of Peak to Average Ratio Measurement

In measuring transmissions in this band using an average power technique, the peak to-average ratio (PAR) of the transmission may not exceed 13 dB.

### 4.6.2 Test Setup

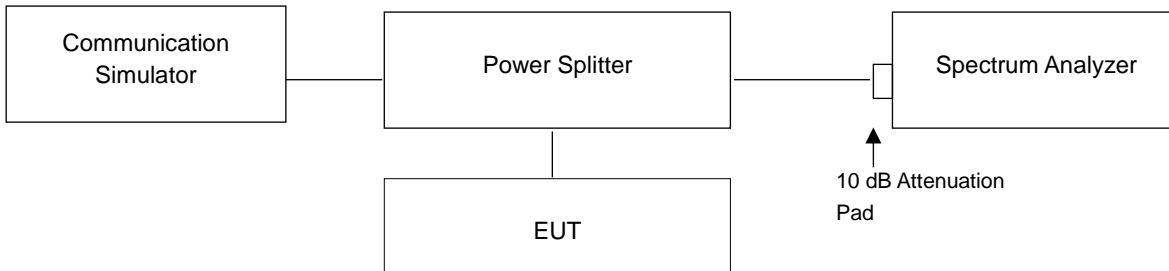

### 4.6.3 Test Procedures

1. Set resolution/measurement bandwidth  $\geq$  signal's occupied bandwidth;
2. Set the number of counts to a value that stabilizes the measured CCDF curve;
3. Record the maximum PAPR level associated with a probability of 0.1 %.

### 4.6.4 Test Results

Channel	Frequency (MHz)	Peak to Average Ratio (dB)
		WCDMA
4132	826.4	2.85
4182	836.4	3.50
4233	846.6	3.03

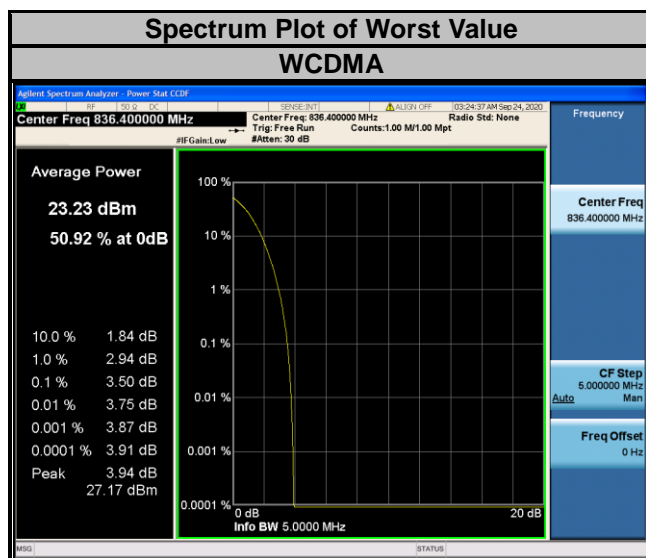

## 4.7 Conducted Spurious Emissions

### 4.7.1 Limits of Conducted Spurious Emissions Measurement

The power of any emission outside of the authorized operating frequency ranges must be attenuated below the transmitting power (P) by a factor of at least  $43 + 10 \log(P)$  dB. The emission limit equal to -13 dBm.

### 4.7.2 Test Setup

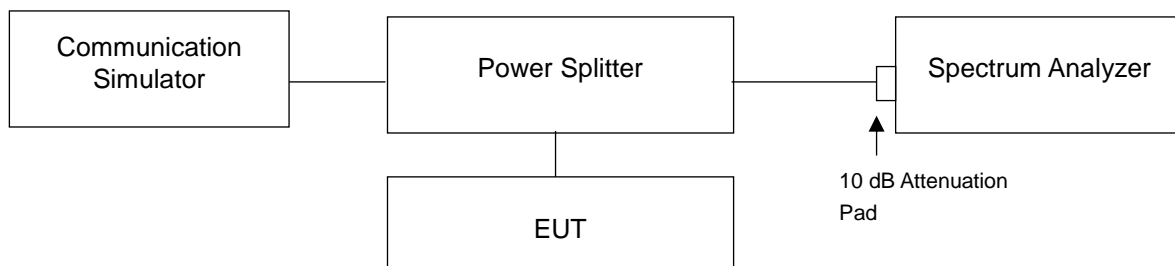

### 4.7.3 Test Procedure

- The EUT makes a phone call to the communication simulator. All measurements were done at low, middle and high operational frequency range.
- Measuring frequency range is from 9 kHz to 1 GHz. 10 dB attenuation pad is connected with spectrum. RBW = 100 kHz and VBW = 300 kHz is used for conducted emission measurement.
- Measuring frequency range is from 1 GHz to 9 GHz. 10 dB attenuation pad is connected with spectrum. RBW = 1 MHz and VBW = 3 MHz is used for conducted emission measurement.

### 4.7.4 Test Results

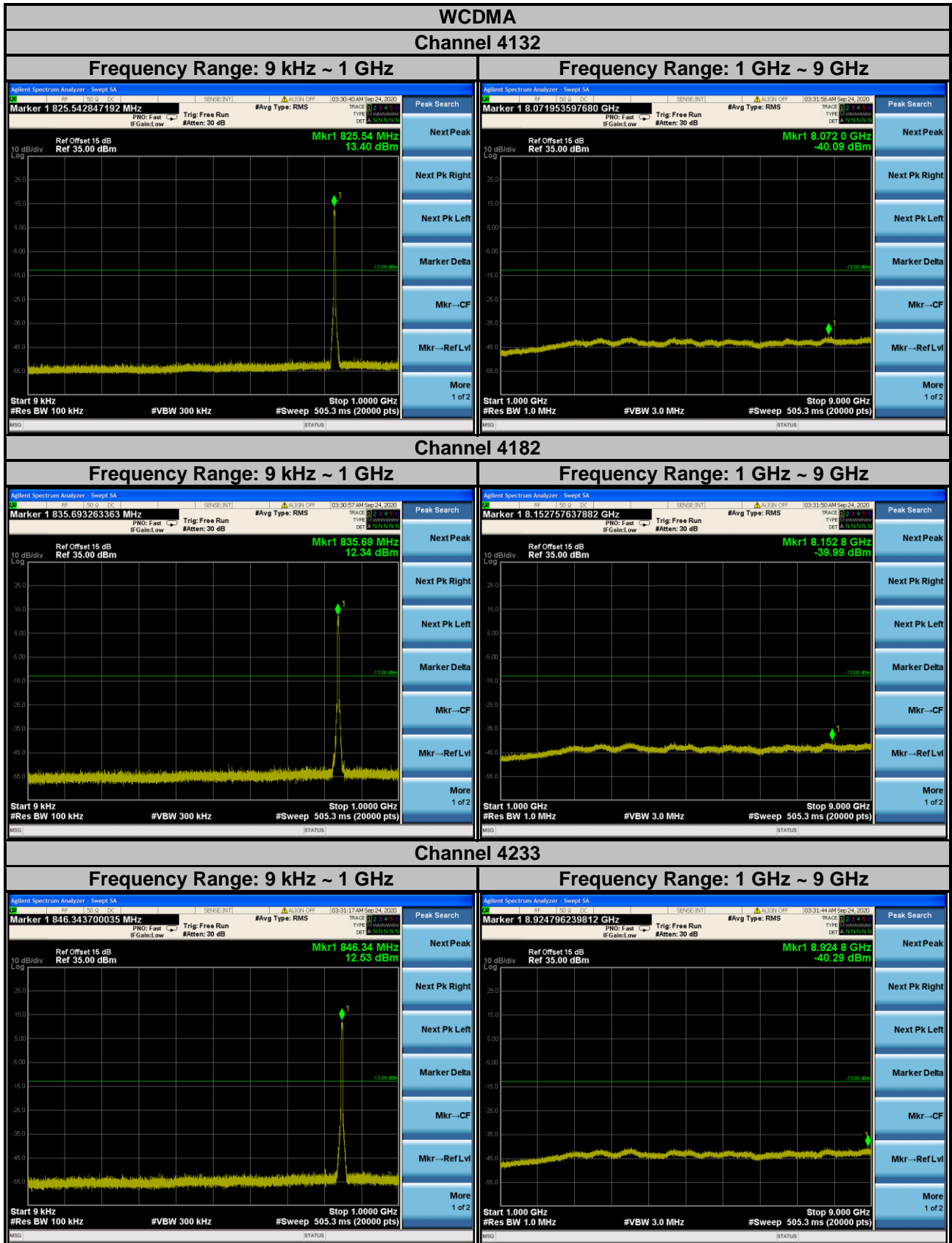

Note: The signal over the limit in 9 kHz is from spectrum analyzer.

## 4.8 Radiated Emission Measurement

### 4.8.1 Limits of Radiated Emission Measurement

The power of any emission outside of the authorized operating frequency ranges must be attenuated below the transmitting power (P) by a factor of at least  $43 + 10 \log(P)$  dB. The emission limit is equal to -13 dBm.

### 4.8.2 Test Procedure

- a. Substitution method is used for E.I.R.P measurement. In the semi-anechoic chamber, EUT placed on the 0.8 m (below or equal 1 GHz) and/or 1.5 m (above 1 GHz) height of Turn Table, rotated the table around 360 degrees to search the maximum radiation power and receiver antenna shall be rotated vertical and horizontal polarization and moved height from 1 m to 4 m to find the maximum polar radiated power. The "Read Value" is the spectrum reading the maximum power value.
- b. EIRP = Output power level of S.G – TX cable loss + Antenna gain of substitution horn.
- c. E.R.P power can be calculated form E.I.R.P power by subtracting the gain of dipole, E.R.P power = E.I.R.P power - 2.15 dB.

#### NOTE:

1. The resolution bandwidth and video bandwidth of test receiver/spectrum analyzer is 1 MHz/3 MHz.
2. The emission levels were against the limit of frequency range 9 kHz ~ 30 MHz:

The amplitude of spurious emissions attenuated more than 20 dB below the permissible value is not required to be report.

### 4.8.3 Deviation from Test Standard

No deviation.

#### 4.8.4 Test Setup

##### <Radiated Emission below or equal 1 GHz>

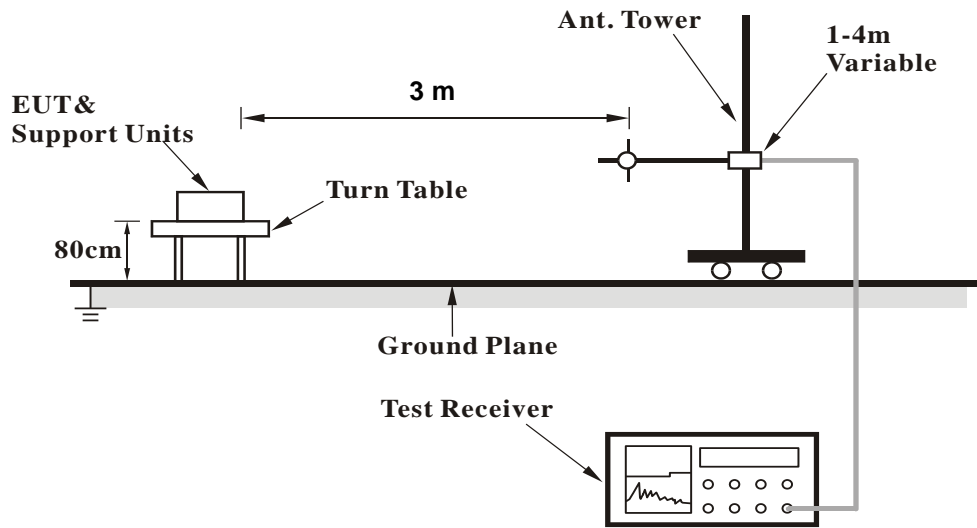

##### <Radiated Emission above 1 GHz>

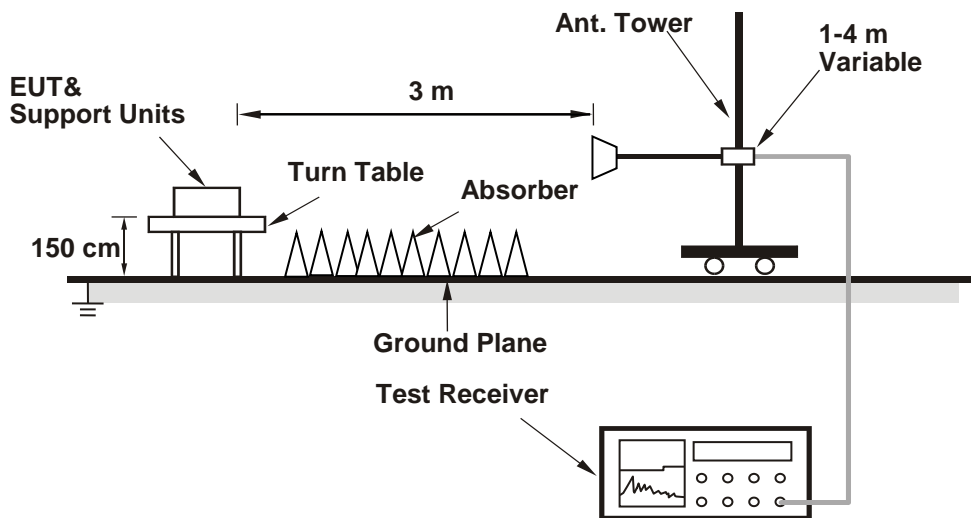

For the actual test configuration, please refer to the attached file (Test Setup Photo).



4.8.5 Test Results

**Mode A**

**WCDMA:**

**Low Channel**



Bureau Veritas Consumer Products Services Ltd., Taoyuan Branch

A D T

Data: 3

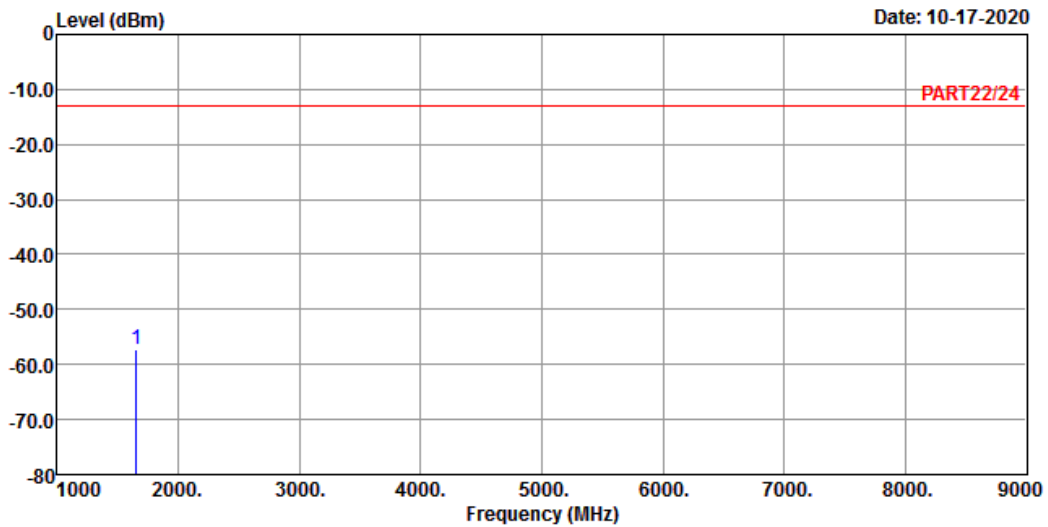

Site : 966 Chamber 5  
 Condition: PART22/24 HORIZONTAL  
 Remak : WCDMA Band 5 Link\_L-CH  
 Tested by: Cyril Chen

Freq	Level	Read Level	Limit	Over	Remark
MHz	dBm	dBm	dBm	dB	dB

1 pp 1652.80 -57.38 -43.61 -13.00 -13.77 -44.38 Peak



Bureau Veritas Consumer Products Services Ltd., Taoyuan Branch

A D T

Data: 4

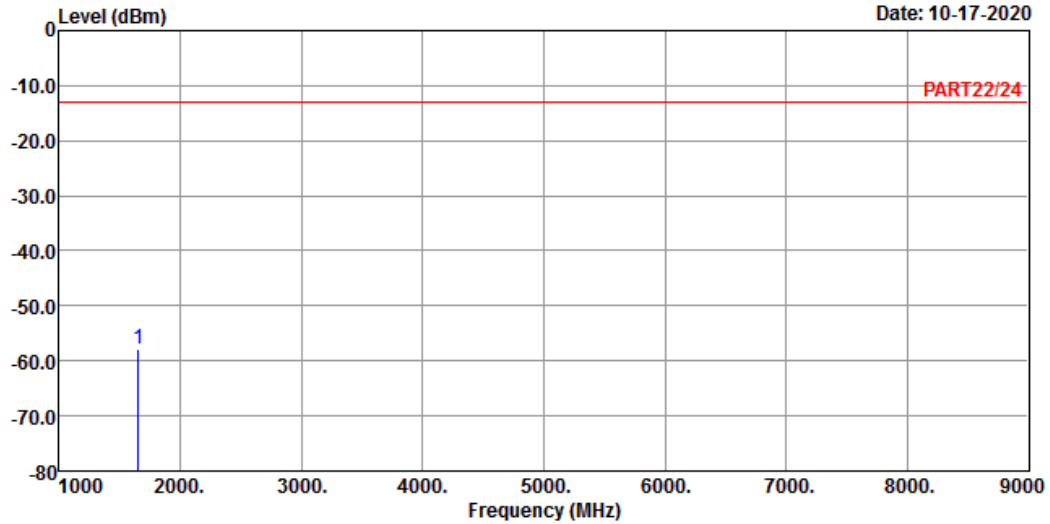

Site : 966 Chamber 5  
 Condition: PART22/24 VERTICAL  
 Remak : WCDMA Band 5 Link\_L-CH  
 Tested by: Cyril Chen

Freq	Level	Read Level	Limit	Line Factor	Over Limit	Remark
MHz	dBm	dBm	dBm	dB	dB	
1 pp 1652.80	-57.93	-44.16	-13.00	-13.77	-44.93	Peak

Middle Channel



Bureau Veritas Consumer Products Services Ltd., Taoyuan Branch

A D T

Data: 3

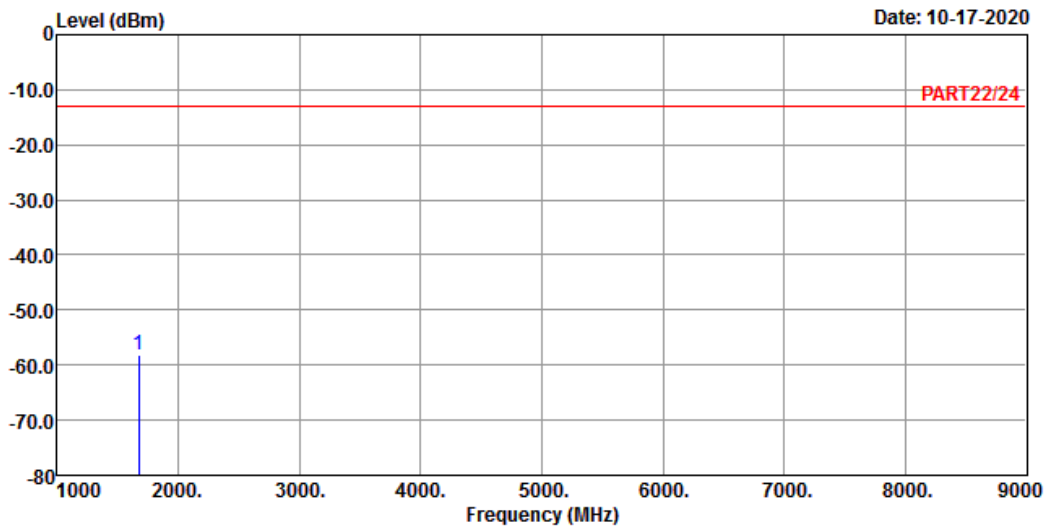

Site : 966 Chamber 5  
 Condition: PART22/24 HORIZONTAL  
 Remak : WCDMA Band 5 Link\_M-CH  
 Tested by: Cyril Chen

Freq	Level	Read Level	Limit	Line Factor	Over Limit	Remark
MHz	dBm	dBm	dBm	dB	dB	

1 pp 1672.80 -58.02 -44.12 -13.00 -13.90 -45.02 Peak



Bureau Veritas Consumer Products Services Ltd., Taoyuan Branch

A D T

Data: 4

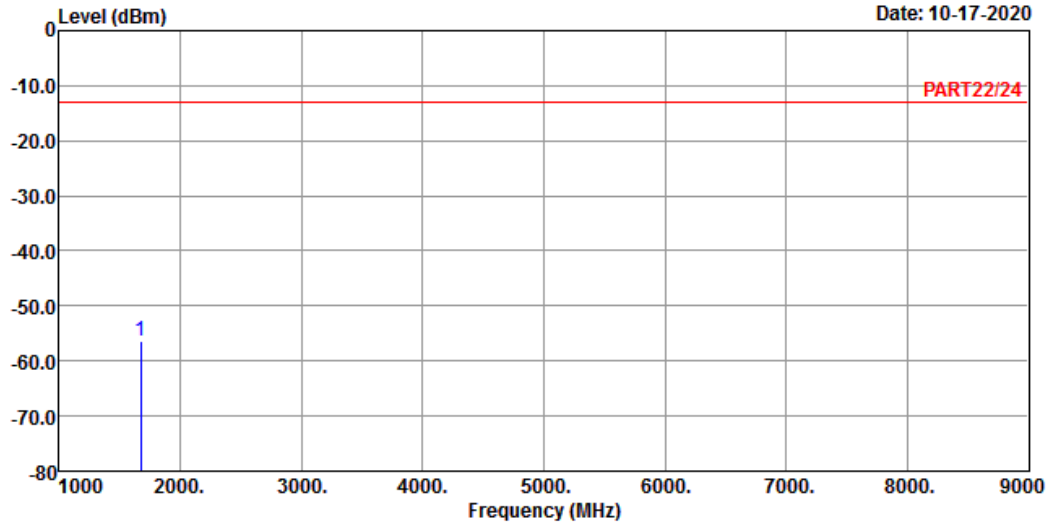

Site : 966 Chamber 5  
 Condition: PART22/24 VERTICAL  
 Remak : WCDMA Band 5 Link\_M-CH  
 Tested by: Cyril Chen

Freq	Level	Read Level	Limit	Line Factor	Over Limit	Remark
MHz	dBm	dBm	dBm	dB	dB	
1 pp 1672.80	-56.44	-42.54	-13.00	-13.90	-43.44	Peak

# High Channel



Bureau Veritas Consumer Products Services Ltd., Taoyuan Branch

A D T

Data: 5

Date: 2020-10-19

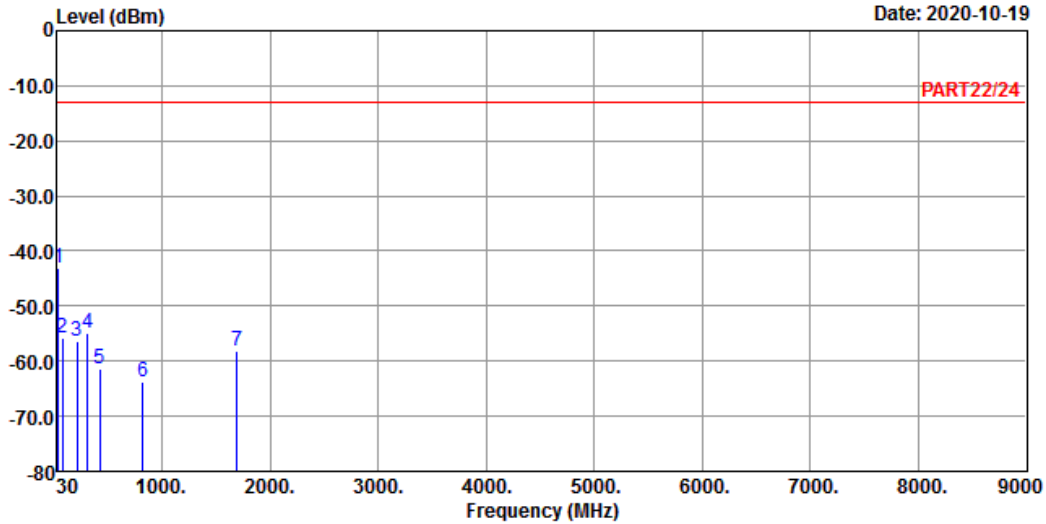

Site : 966 Chamber 5  
 Condition: PART22/24 HORIZONTAL  
 Remak : WCDMA Band 5 Link\_H-CH  
 Tested by: Cyril Chen

	Freq	Level	Read Level	Limit	Line Factor	Over Limit	Remark
	MHz	dBm	dBm	dBm	dB	dB	
1 pp	42.61	-43.01	-42.07	-13.00	-0.94	-30.01	Peak
2	77.53	-55.76	-45.56	-13.00	-10.20	-42.76	Peak
3	212.36	-56.47	-48.96	-13.00	-7.51	-43.47	Peak
4	308.39	-55.04	-48.16	-13.00	-6.88	-42.04	Peak
5	424.79	-61.42	-55.67	-13.00	-5.75	-48.42	Peak
6	822.49	-63.67	-64.21	-13.00	0.54	-50.67	Peak
7	1693.20	-58.14	-44.12	-13.00	-14.02	-45.14	Peak



Bureau Veritas Consumer Products Services Ltd., Taoyuan Branch

A D T

Data: 6

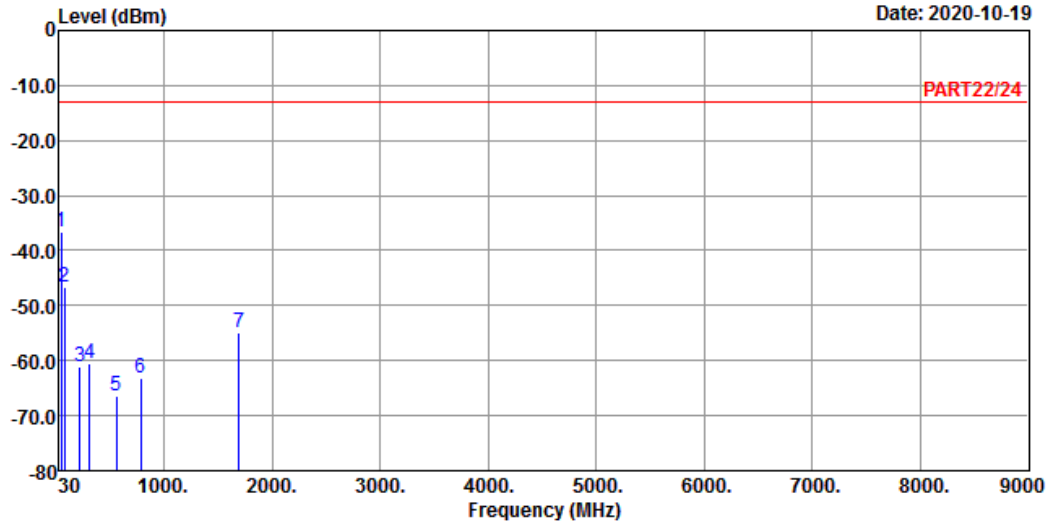

Site : 966 Chamber 5  
 Condition: PART22/24 VERTICAL  
 Remak : WCDMA Band 5 Link\_H-CH  
 Tested by: Cyril Chen

	Freq	Level	Read Level	Limit Line	Over Factor	Over Limit	Remark
	MHz	dBm	dBm	dBm	dB	dB	
1 pp	44.55	-36.73	-34.74	-13.00	-1.99	-23.73	Peak
2	77.53	-46.58	-36.38	-13.00	-10.20	-33.58	Peak
3	220.12	-61.08	-53.88	-13.00	-7.20	-48.08	Peak
4	309.36	-60.56	-53.70	-13.00	-6.86	-47.56	Peak
5	559.62	-66.52	-64.07	-13.00	-2.45	-53.52	Peak
6	781.75	-63.08	-63.87	-13.00	0.79	-50.08	Peak
7	1693.20	-54.91	-40.89	-13.00	-14.02	-41.91	Peak

**Mode B**  
**WCDMA:**  
**Low Channel**



Bureau Veritas Consumer Products Services Ltd., Taoyuan Branch

A D T

Data: 3

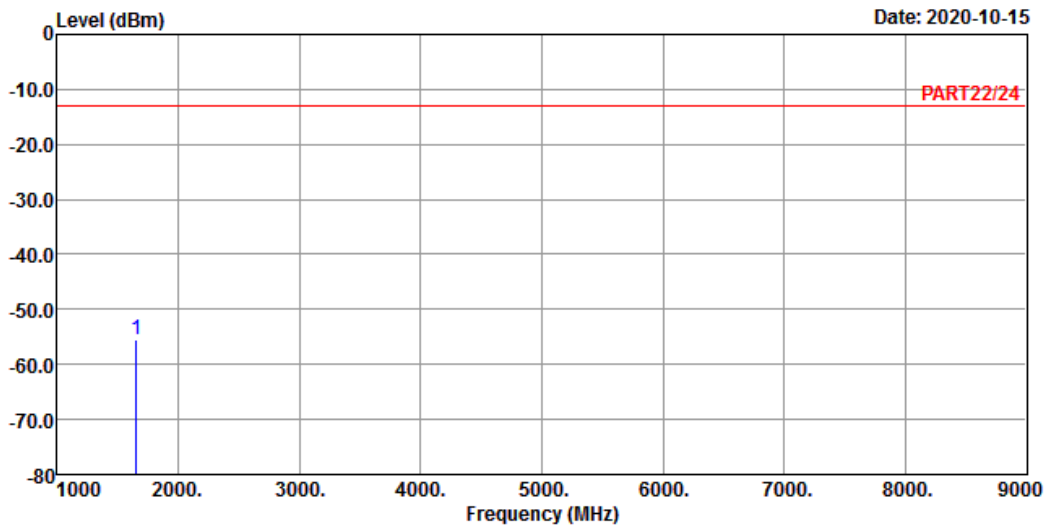

Site : 966 Chamber 5  
 Condition: PART22/24 HORIZONTAL  
 Remak : WCDMA Band 5 Link\_L-CH  
 Tested by: tim-chen

Freq	Level	Read Level	Limit	Line Factor	Over Limit	Remark
MHz	dBm	dBm	dBm	dB	dB	
1 pp 1652.80	-55.62	-41.85	-13.00	-13.77	-42.62	Peak



Bureau Veritas Consumer Products Services Ltd., Taoyuan Branch

A D T

Data: 4

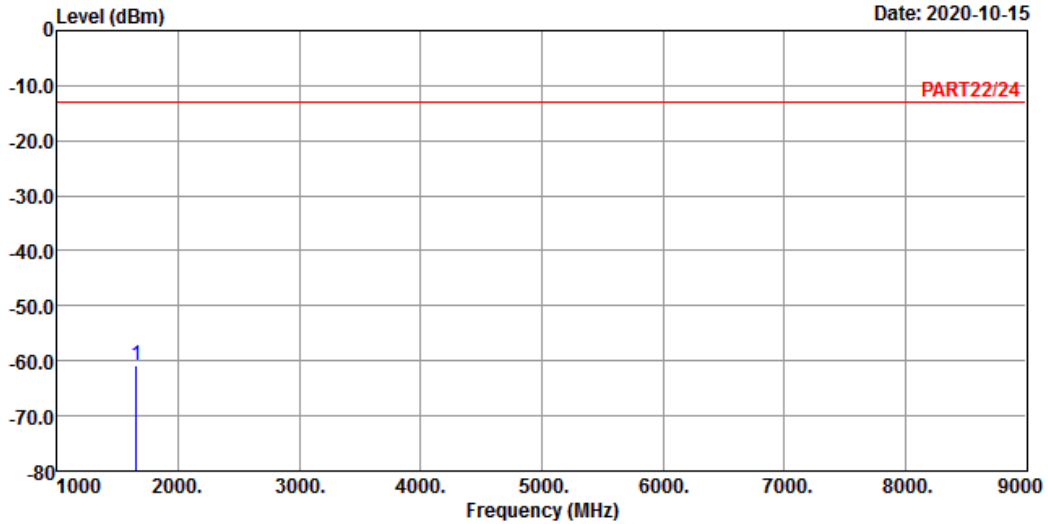

Site : 966 Chamber 5  
 Condition: PART22/24 VERTICAL  
 Remak : WCDMA Band 5 Link\_L-CH  
 Tested by: tim-chen

Freq	Level	Read Level	Limit	Over	Remark
MHz	dBm	dBm	dBm	dB	
1 pp 1652.80	-60.68	-46.91	-13.00	-13.77	-47.68 Peak



### Middle Channel



Bureau Veritas Consumer Products Services Ltd., Taoyuan Branch

A D T

Data: 5

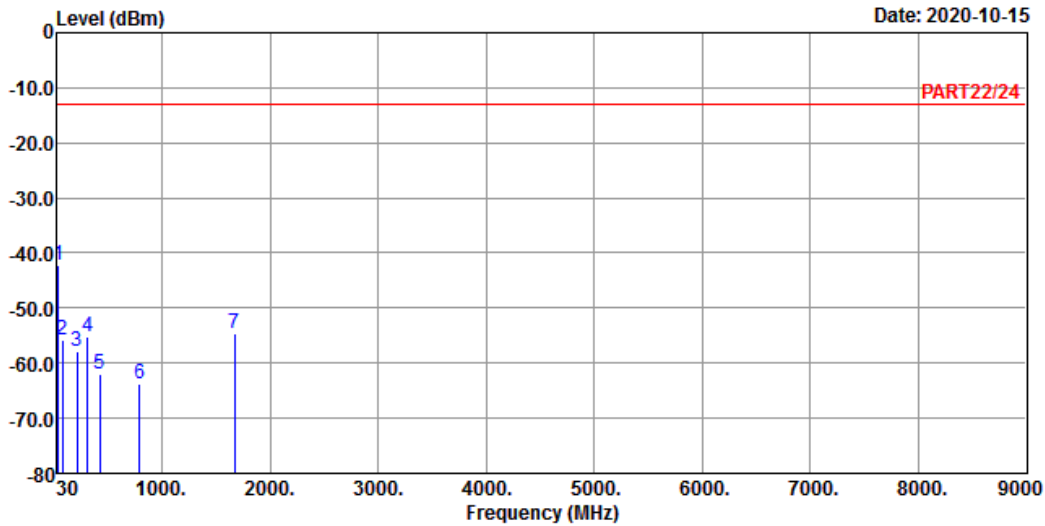

Site : 966 Chamber 5  
 Condition: PART22/24 HORIZONTAL  
 Remak : WCDMA Band 5 Link\_M-CH  
 Tested by: tim-chen

	Freq	Level	Read Level	Limit	Line Factor	Over Limit	Remark
	MHz	dBm	dBm	dBm	dB	dB	
1 pp	42.61	-42.08	-41.14	-13.00	-0.94	-29.08	Peak
2	76.56	-55.76	-45.78	-13.00	-9.98	-42.76	Peak
3	211.39	-57.98	-50.43	-13.00	-7.55	-44.98	Peak
4	309.36	-55.08	-48.22	-13.00	-6.86	-42.08	Peak
5	422.85	-61.85	-56.09	-13.00	-5.76	-48.85	Peak
6	790.48	-63.73	-64.49	-13.00	0.76	-50.73	Peak
7	1672.00	-54.75	-40.85	-13.00	-13.90	-41.75	Peak



Bureau Veritas Consumer Products Services Ltd., Taoyuan Branch

A D T

Data: 6

Date: 2020-10-15

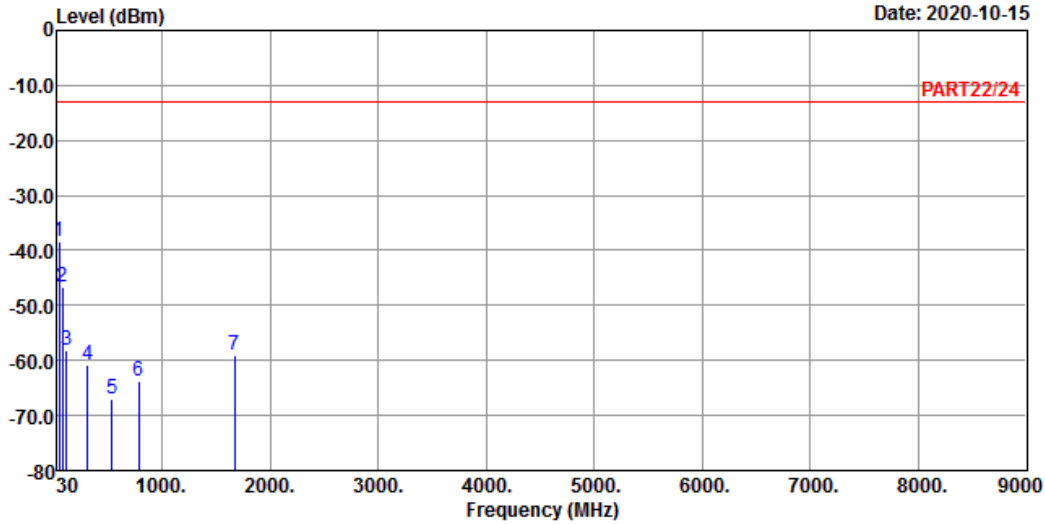

Site : 966 Chamber 5  
 Condition: PART22/24 VERTICAL  
 Remak : WCDMA Band 5 Link\_M-CH  
 Tested by: tim-chen

	Freq	Level	Read Level	Limit	Line Factor	Over Limit	Remark
	MHz	dBm	dBm	dBm	dB	dB	
1 pp	43.58	-38.31	-36.84	-13.00	-1.47	-25.31	Peak
2	76.56	-46.79	-36.81	-13.00	-9.98	-33.79	Peak
3	114.39	-58.10	-47.99	-13.00	-10.11	-45.10	Peak
4	309.36	-60.76	-53.90	-13.00	-6.86	-47.76	Peak
5	536.34	-66.90	-63.57	-13.00	-3.33	-53.90	Peak
6	782.72	-63.91	-64.70	-13.00	0.79	-50.91	Peak
7	1672.00	-59.00	-45.10	-13.00	-13.90	-46.00	Peak

# High Channel



Bureau Veritas Consumer Products Services Ltd., Taoyuan Branch

A D T

Data: 3

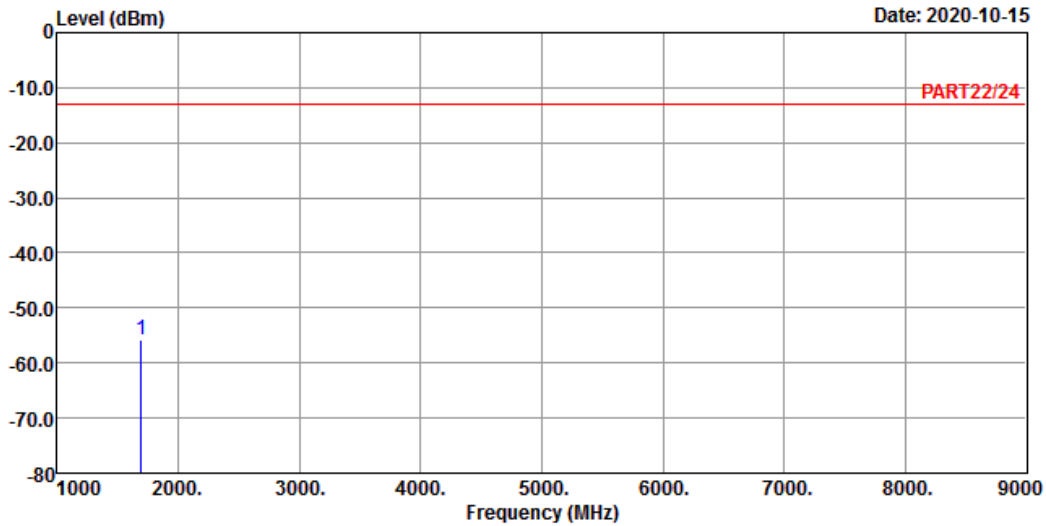

Site : 966 Chamber 5  
 Condition: PART22/24 HORIZONTAL  
 Remak : WCDMA Band 5 Link\_H-CH  
 Tested by: tim-chen

Freq	Level	Read Level	Limit	Line Factor	Over Limit	Remark
MHz	dBm	dBm	dBm	dB	dB	
1 pp 1693.20	-55.69	-41.67	-13.00	-14.02	-42.69	Peak



Bureau Veritas Consumer Products Services Ltd., Taoyuan Branch

A D T

Data: 4

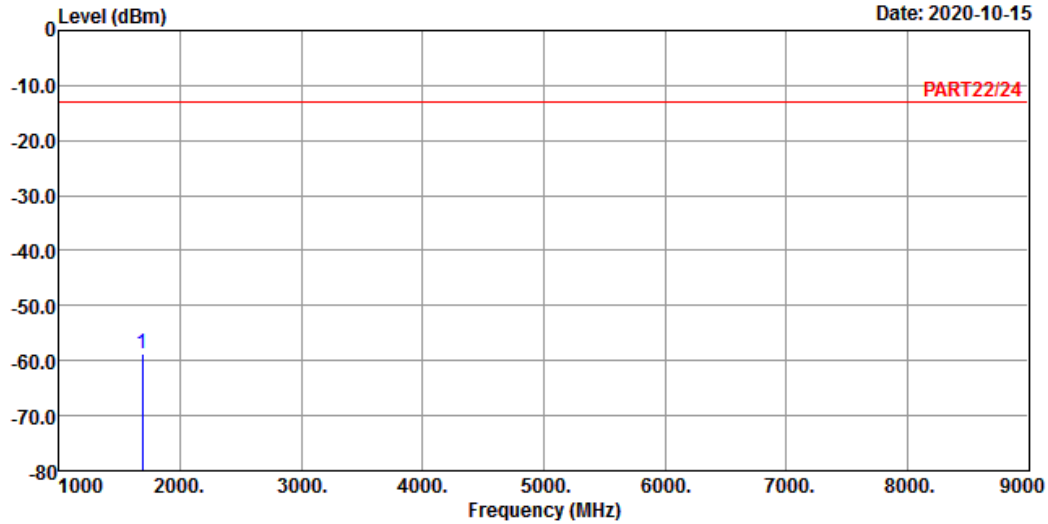

Site : 966 Chamber 5  
 Condition: PART22/24 VERTICAL  
 Remak : WCDMA Band 5 Link\_H-CH  
 Tested by: tim-chen

Freq	Level	Read Level	Limit	Over	Remark
MHz	dBm	dBm	dBm	dB	

1 pp 1688.00 -58.74 -44.75 -13.00 -13.99 -45.74 Peak

## 5 Pictures of Test Arrangements

Please refer to the attached file (Test Setup Photo).

## Appendix – Information of the Testing Laboratories

We, Bureau Veritas Consumer Products Services (H.K.) Ltd., Taoyuan Branch, were founded in 1988 to provide our best service in EMC, Radio, Telecom and Safety consultation. Our laboratories are FCC recognized accredited test firms and accredited according to ISO/IEC 17025.

If you have any comments, please feel free to contact us at the following:

**Lin Kou EMC/RF Lab**

Tel: 886-2-26052180

Fax: 886-2-26051924

**Hsin Chu EMC/RF/Telecom Lab**

Tel: 886-3-6668565

Fax: 886-3-6668323

**Hwa Ya EMC/RF/Safety Lab**

Tel: 886-3-3183232

Fax: 886-3-3270892

**Email:** [service.adt@tw.bureauveritas.com](mailto:service.adt@tw.bureauveritas.com)

**Web Site:** [www.bureauveritas-adt.com](http://www.bureauveritas-adt.com)

The address and road map of all our labs can be found in our web site also.

--- END ---