

## 6.6 Frequency Stability

Manufacturers ensured the EUT meet the requirement of frequency stability, such that an emission is maintained within the band of operation under all conditions of normal operation as specified in the user's manual.(According to15.407(g) and RSS-Gen 8.11)

## 6.7 Transmitter Spurious Emission

### 6.7.1 Measurement Limit

#### Below 1G:

| Frequency of emission (MHz) | Field strength(dB $\mu$ V/m) | Measurement distance(m) |
|-----------------------------|------------------------------|-------------------------|
| 0.009-0.490                 | 129-94                       | 3                       |
| 0.490-1.705                 | 74-63                        | 3                       |
| 1.705-30                    | 70                           | 3                       |
| 30-88                       | 40.0                         | 3                       |
| 88-216                      | 43.5                         | 3                       |
| 216-960                     | 46.0                         | 3                       |
| Above 960                   | 54.0                         | 3                       |

Note: for frequency range below 960MHz, the limit in 15.209 is defined in 10m test distance. The limit used above is calculated from 10m to 3m

#### Above 1G, non-restricted band:

| Standard  | Limit             |
|-----------|-------------------|
| 15.407(b) | EIRP < -27dBm/MHz |

#### Above 1G, Restricted band:

| Standard  | Limit             |                |
|-----------|-------------------|----------------|
| 15.407(b) | EIRP < -27dBm/MHz |                |
| 15.209    | Peak              | 74dB $\mu$ V/m |
|           | Average           | 54dB $\mu$ V/m |

$$\text{EIRP[dBm]} = \text{E[dB}\mu\text{V/m]} + 20 \log(d[\text{m}]) - 104.7$$

$$\text{E[dB}\mu\text{V/m]} = \text{EIRP[dBm]} - 20 \log(d[\text{m}]) + 104.7$$

$$\text{E[dB}\mu\text{V/m]} = \text{EIRP[dBm]} + 95.2 = 68.2, \text{ for } d = 3\text{m}$$

### 6.7.2 Test procedures

The measurement is made according to KDB 789033

Set the spectrum analyzer in the following:

#### Procedure for Unwanted Emissions Measurements below 1000 MHz:

- Follow the requirements in II.G.3. "General Requirements for Unwanted Emissions Measurements."
- Compliance shall be demonstrated using CISPR quasi-peak detection; however, peak detection is permitted as an alternative to quasi-peak detection.

Detector: Peak and Quasi-Peak

RBW=100kHz / VBW=300kHz / Sweep=AUTO

#### Procedure for Unwanted Maximum Emissions Measurements above 1000 MHz:

- a) Follow the requirements in II.G.3, “General Requirements for Unwanted Emissions Measurements.”
- b) Maximum emission levels are measured by setting the analyzer as follows:
  - (i) RBW = 1 MHz.
  - (ii) VBW  $\geq$  3 MHz.
  - (iii) Detector = Peak.
  - (iv) Sweep time = auto.
  - (v) Trace mode = max hold.
  - (vi) Allow sweeps to continue until the trace stabilizes. Note that if the transmission is not continuous, the time required for the trace to stabilize will increase by a factor of approximately  $1/x$ , where  $x$  is the duty cycle. For example, at 50% duty cycle, the measurement time will increase by a factor of two relative to measurement time for continuous transmission.

**Procedures for Average Unwanted Emissions Measurements above 1000 MHz:**

- a) Follow the requirements in section II.G.3., “General Requirements for Unwanted Emissions Measurements.”
- b) Average emission levels shall be measured using one of the following two methods.
- c) Method AD (Average Detection): Primary method
  - (i) RBW = 1 MHz.
  - (ii) VBW  $\geq$  3 MHz.
  - (iii) Detector = power averaging (rms), if span/(# of points in sweep)  $\leq$  RBW/2. Satisfying this condition may require increasing the number of points in the sweep or reducing the span. If the condition is not satisfied, the detector mode shall be set to peak.
  - (iv) Averaging type = power averaging (rms)

As an alternative, the detector and averaging type may be set for linear voltage averaging. Some instruments require linear display mode in order to use linear voltage averaging. Log or dB averaging shall not be used.
  - (v) Sweep time = auto.
  - (vi) Perform a trace average of at least 100 traces if the transmission is continuous. If the transmission is not continuous, the number of traces shall be increased by a factor of  $1/x$ , where  $x$  is the duty cycle. For example, with 50% duty cycle, at least 200 traces shall be averaged. (If a specific emission is demonstrated to be continuous—i.e., 100% duty cycle—rather than turning on and off with the transmit cycle, at least 100 traces shall be averaged.)
  - (vii) If tests are performed with the EUT transmitting at a duty cycle less than 98%, a correction factor shall be added to the measurement results prior to comparing to the emission limit in order to compute the emission level that would have been measured had the test been performed at 100% duty cycle. The correction factor is computed as follows:

If power averaging (rms) mode was used in step (iv) above, the correction factor is  $10 \log (1/x)$ , where  $x$  is the duty cycle. For example, if the transmit duty cycle was 50%, then 3 dB must be added to the measured emission levels.

If linear voltage averaging mode was used in step (iv) above, the correction factor is  $20 \log (1/x)$ , where  $x$  is the duty cycle. For example, if the transmit duty cycle was 50%, then 6 dB must be added to the measured emission levels.

If a specific emission is demonstrated to be continuous (100% duty cycle) rather than turning on and off with the transmit cycle, no duty cycle correction is required for that emission.

Portable, small, lightweight, or modular devices that may be handheld, worn on the body, or placed on a table during operation shall be positioned on a non-conducting platform, the top of which is 80 cm above the reference ground plane. The preferred area occupied by the EUT arrangement is 1 m by 1.5 m, For emissions testing at or below 1 GHz, the table height shall be 80 cm above the reference ground plane. For emission measurements above 1 GHz, the table height shall be 1.5 m. but it may be larger or smaller to accommodate various sized EUTs. For testing purposes, ceiling- and wall-mounted devices also shall be positioned on a tabletop (see also ANSI C63.10-2013 section 6.3.4 and 6.3.5). In making any tests involving handheld, body-worn, or ceiling-mounted equipment, it is essential to recognize that the measured levels may be dependent on the orientation (attitude) of the three orthogonal axes of the EUT. Thus, exploratory tests as specified in 8.3.1 shall be carried out for various axes orientations to determine the attitude having maximum or near-maximum emission level.

The EUT was placed on a non-conductive table. Below 18GHz , the measurement antenna was placed at a distance of 3 meters from the EUT. Above 18GHz , the measurement antenna was placed at a distance of 1 meter from the EUT. During the tests, the antenna height varied from 1m to 4m and the EUT azimuth were varied from 0° to 360° in order to identify the maximum level of emissions from the EUT. This maximization process was repeated with the EUT positioned in each of its three orthogonal orientations.

Remark:

1. Factor= Antenna Factor + Cable Loss (-Amplifier, is employed)
2. Measured level= Original Receiver Reading + Factor
3. Margin = Limit – Measured level
4. If the PK measured level is lower than AV limit, the AV test can be elided

#### 6.7.3 Test Setup

##### Below 30MHz Test Setup

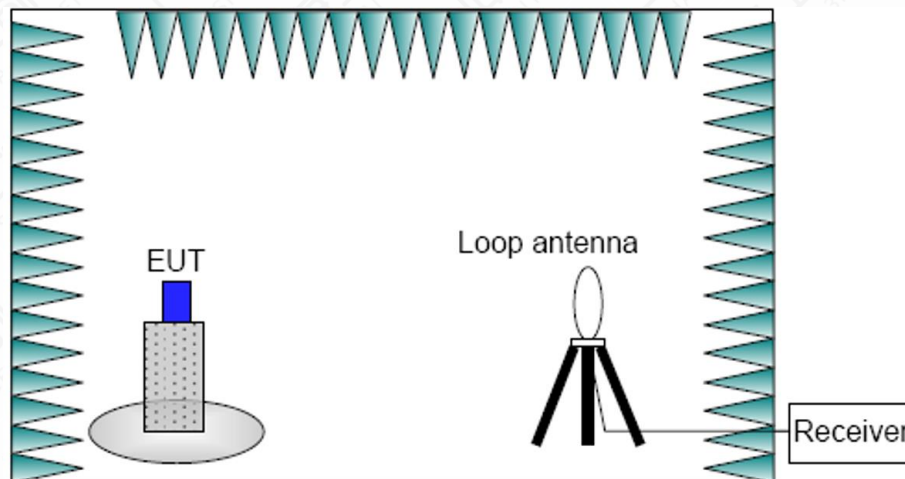



## Below 1GHz Test Setup

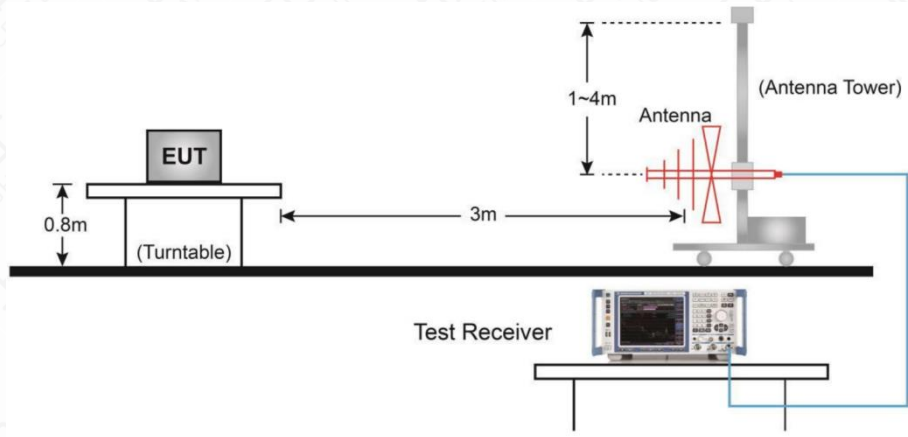

## Above 1GHz Test Setup

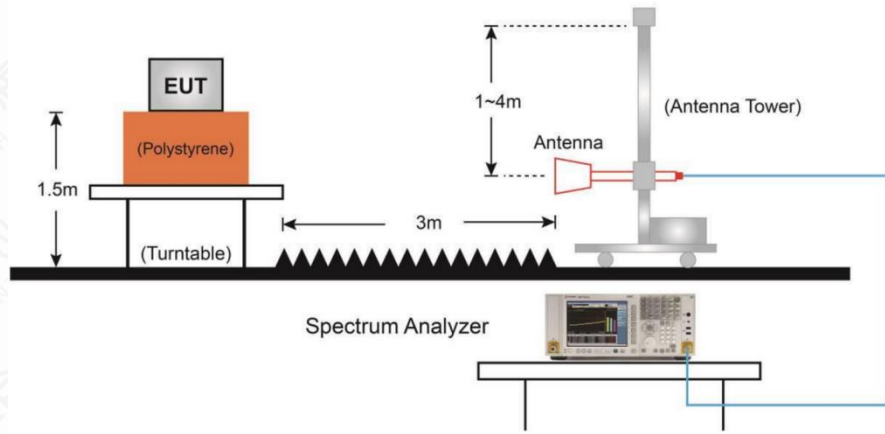

## 6.7.4 Measurement Results

| Mode       | Channel      | Frequency Range   | Conclusion |
|------------|--------------|-------------------|------------|
| 11A-CDD    | 149(5745MHz) | 30 MHz ~ 1 GHz    | P          |
|            |              | 1 GHz ~ 8 GHz     | P          |
|            |              | 8 GHz ~ 18 GHz    | P          |
|            |              | 18 GHz ~ 26.5 GHz | P          |
|            |              | 26.5 GHz ~ 40 GHz | P          |
| 11N20 MIMO | 157(5785MHz) | 30 MHz ~ 1 GHz    | P          |
|            |              | 1 GHz ~ 8 GHz     | P          |
|            |              | 8 GHz ~ 18 GHz    | P          |
|            |              | 18 GHz ~ 26.5 GHz | P          |
|            |              | 26.5 GHz ~ 40 GHz | P          |
| 11N40 MIMO | 159(5795MHz) | 30 MHz ~ 1 GHz    | P          |
|            |              | 1 GHz ~ 8 GHz     | P          |
|            |              | 8 GHz ~ 18 GHz    | P          |

|             |              |                   |   |
|-------------|--------------|-------------------|---|
|             |              | 18 GHz ~ 26.5 GHz | P |
|             |              | 26.5 GHz~ 40 GHz  | P |
| 11AC20 MIMO | 165(5825MHz) | 30 MHz ~1 GHz     | P |
|             |              | 1 GHz ~ 8 GHz     | P |
|             |              | 8 GHz ~ 18 GHz    | P |
|             |              | 18 GHz ~ 26.5 GHz | P |
|             |              | 26.5 GHz~ 40 GHz  | P |
|             |              |                   |   |
| 11AC40 MIMO | 151(5755MHz) | 30 MHz ~1 GHz     | P |
|             |              | 1 GHz ~ 8 GHz     | P |
|             |              | 8 GHz ~ 18 GHz    | P |
|             |              | 18 GHz ~ 26.5 GHz | P |
|             |              | 26.5 GHz~ 40 GHz  | P |
|             |              |                   |   |
| 11AC80 MIMO | 155(5775MHz) | 30 MHz ~1 GHz     | P |
|             |              | 1 GHz ~ 8 GHz     | P |
|             |              | 8 GHz ~ 18 GHz    | P |
|             |              | 18 GHz ~ 26.5 GHz | P |
|             |              | 26.5 GHz~ 40 GHz  | P |
|             |              |                   |   |
| 11AX20 MIMO | 165(5825MHz) | 30 MHz ~1 GHz     | P |
|             |              | 1 GHz ~ 8 GHz     | P |
|             |              | 8 GHz ~ 18 GHz    | P |
|             |              | 18 GHz ~ 26.5 GHz | P |
|             |              | 26.5 GHz~ 40 GHz  | P |
|             |              |                   |   |
| 11AX40 MIMO | 151(5755MHz) | 30 MHz ~1 GHz     | P |
|             |              | 1 GHz ~ 8 GHz     | P |
|             |              | 8 GHz ~ 18 GHz    | P |
|             |              | 18 GHz ~ 26.5 GHz | P |
|             |              | 26.5 GHz~ 40 GHz  | P |
|             |              |                   |   |
| 11AX80 MIMO | 155(5775MHz) | 30 MHz ~1 GHz     | P |
|             |              | 1 GHz ~ 8 GHz     | P |
|             |              | 8 GHz ~ 18 GHz    | P |
|             |              | 18 GHz ~ 26.5 GHz | P |
|             |              | 26.5 GHz~ 40 GHz  | P |
|             |              |                   |   |

Test graphs as below

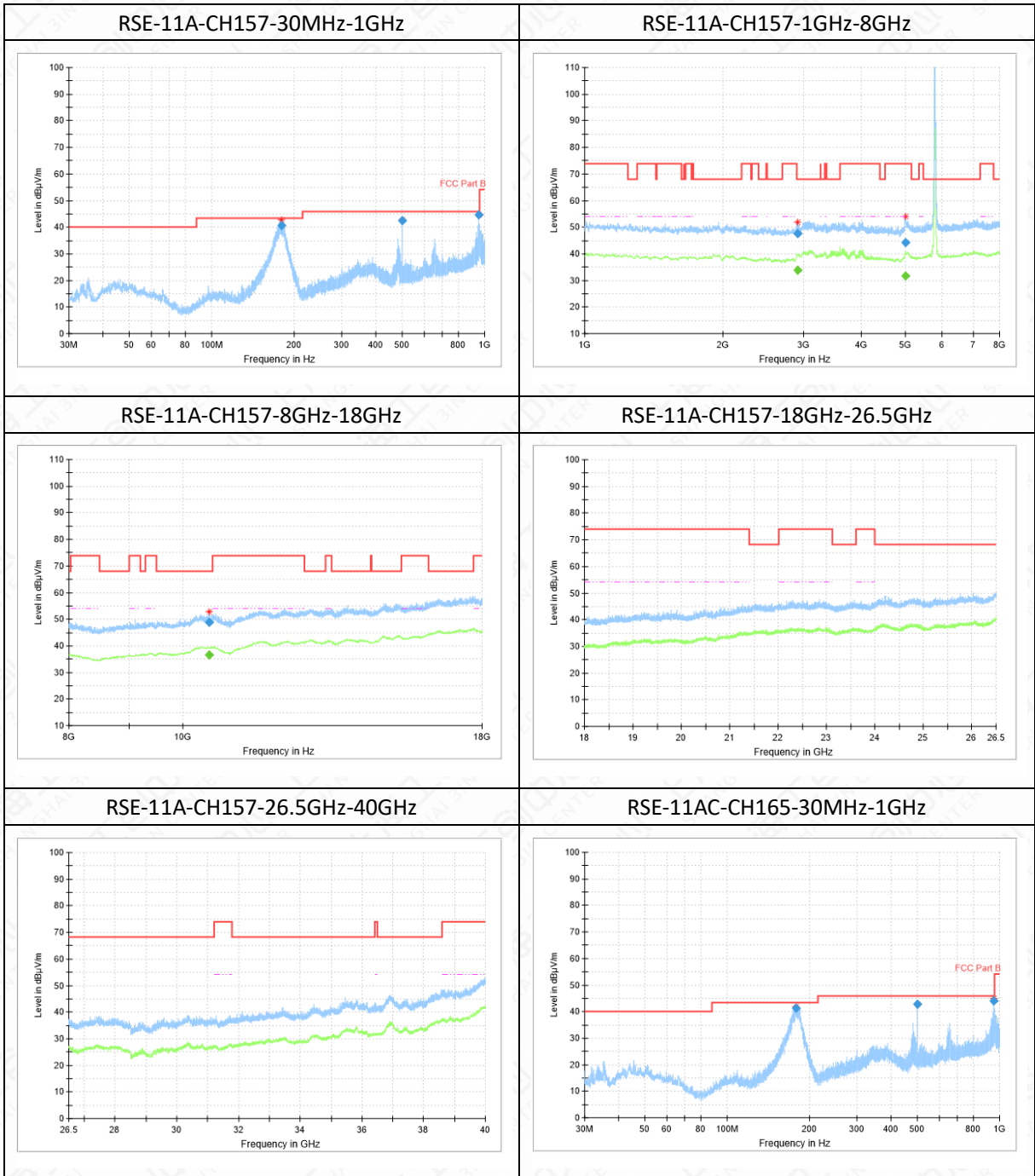

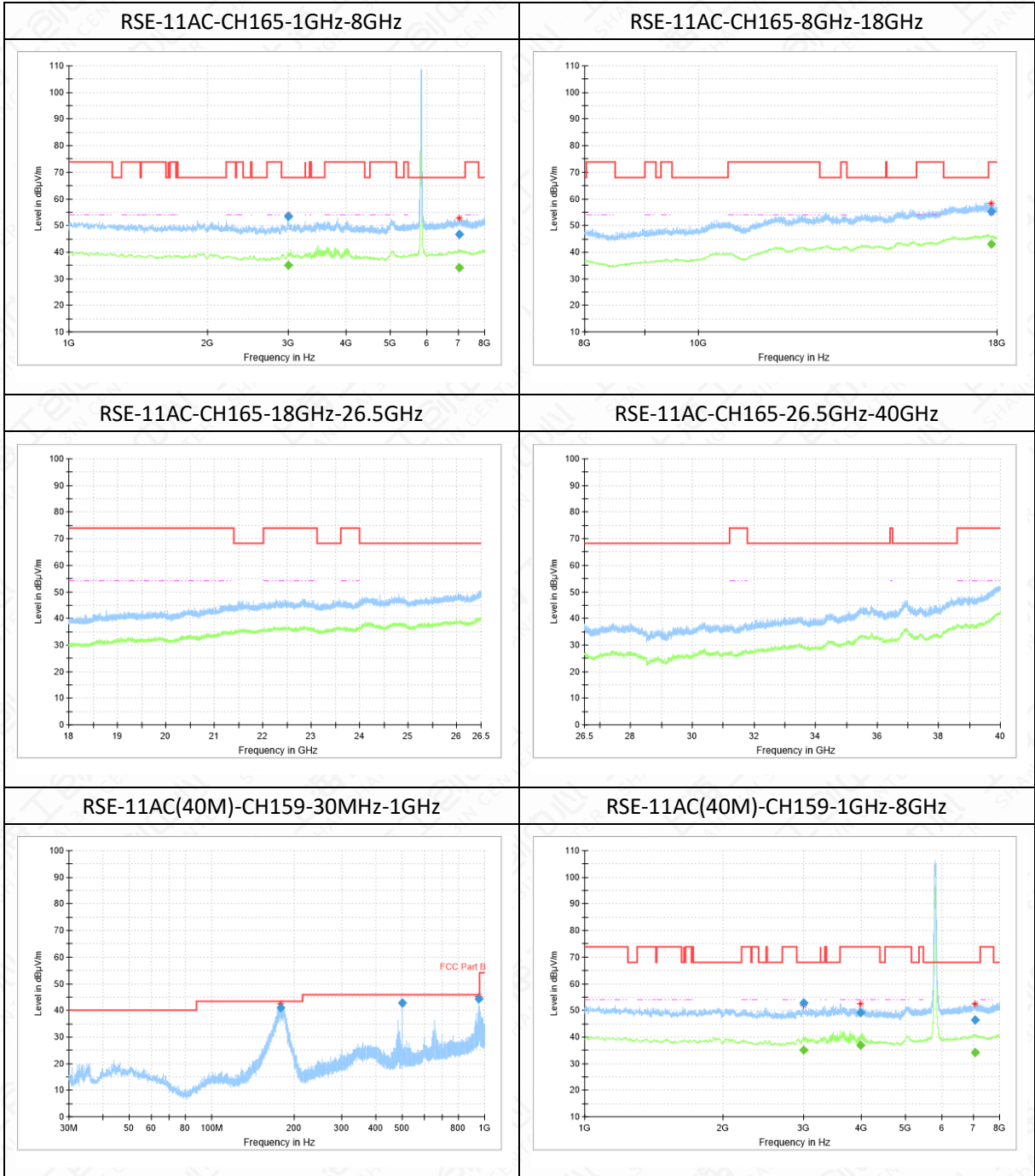

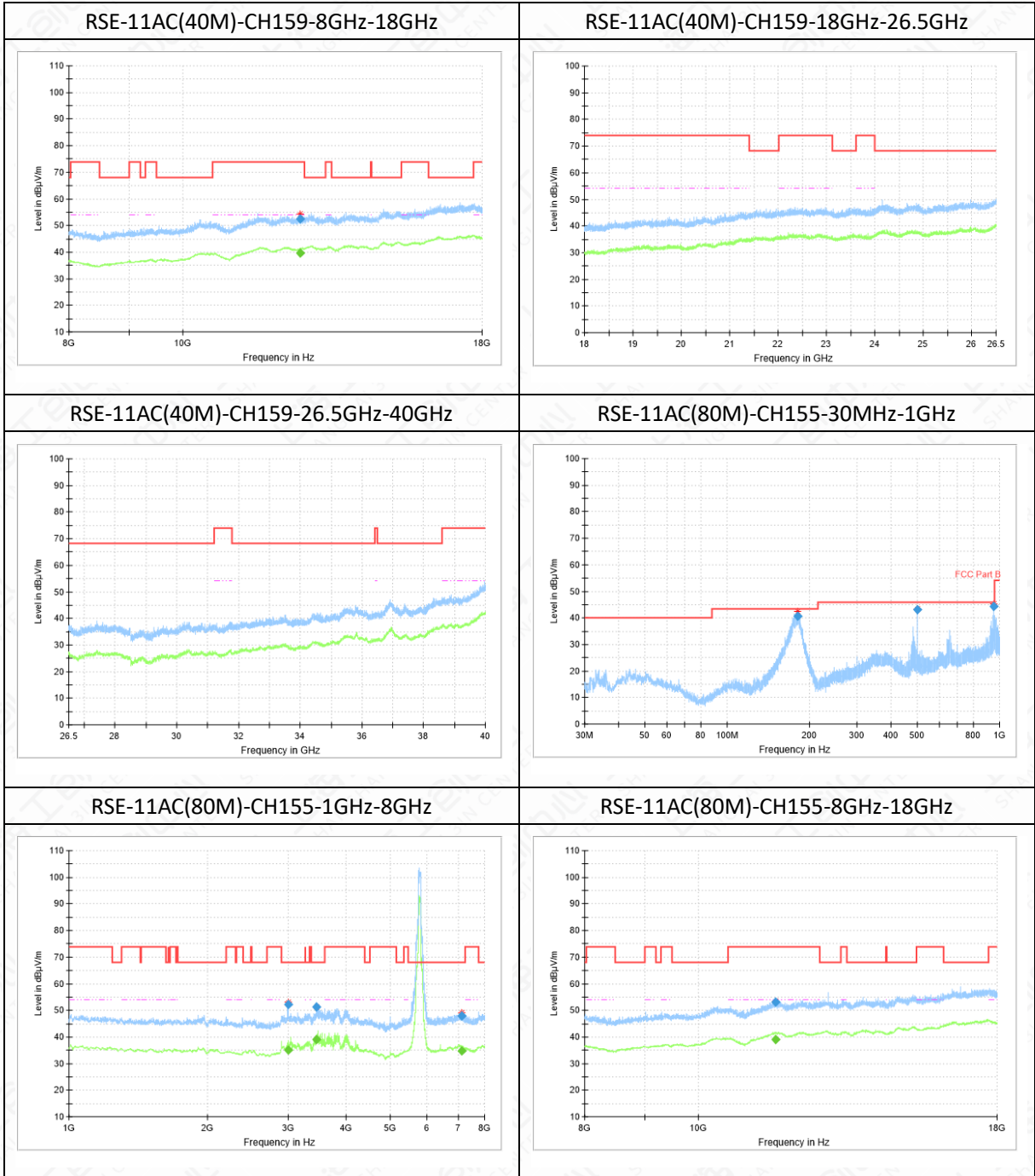

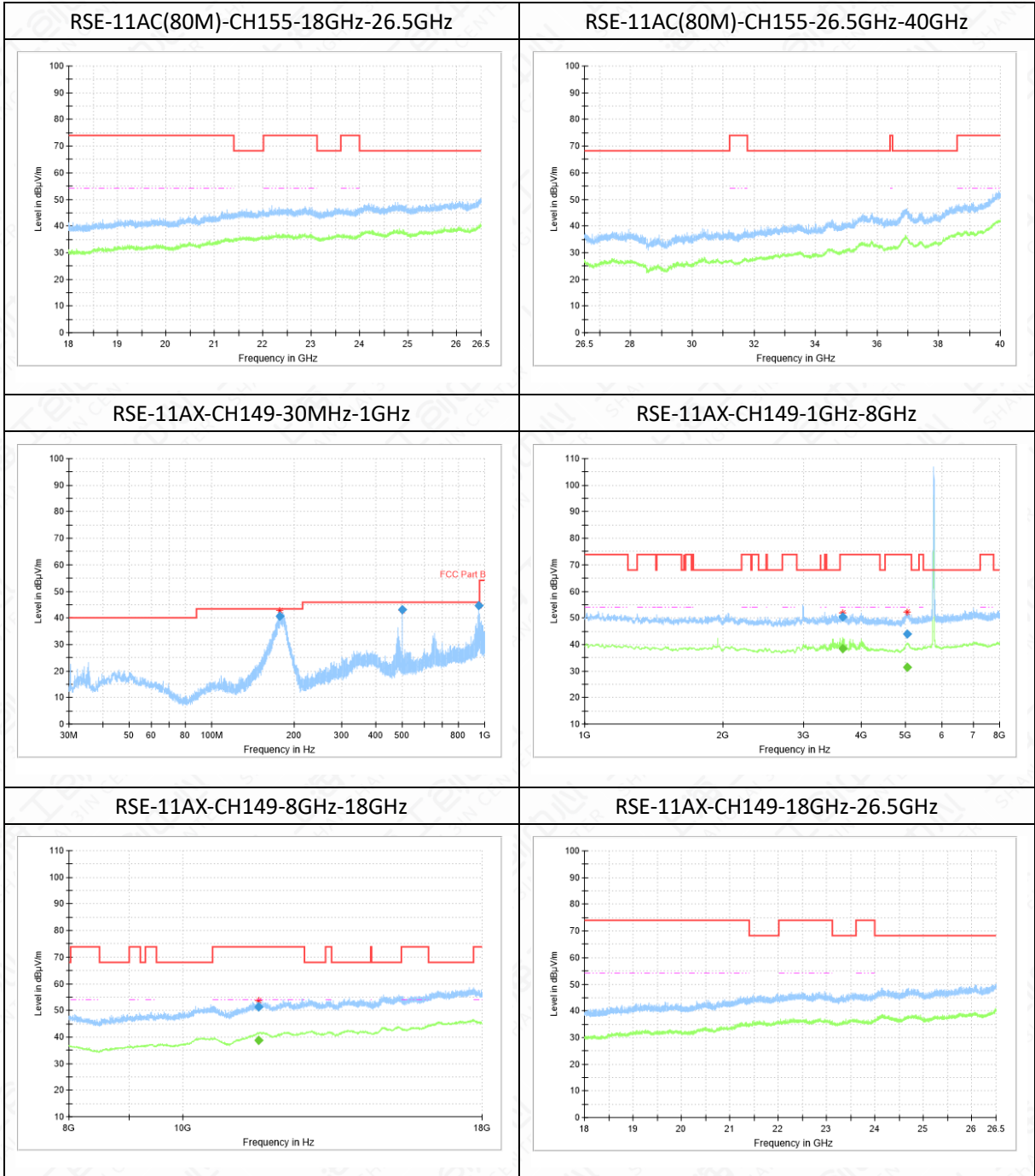

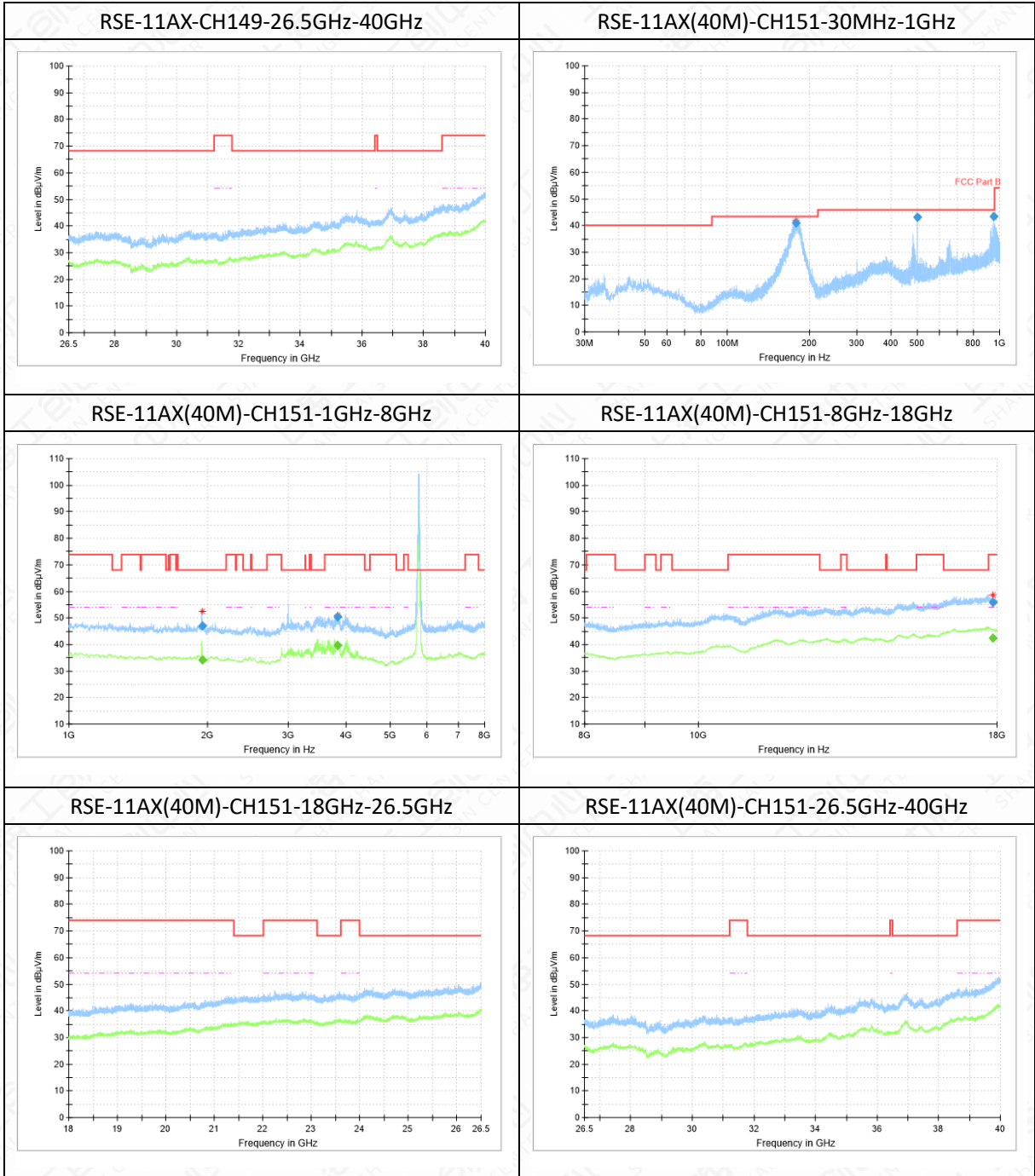

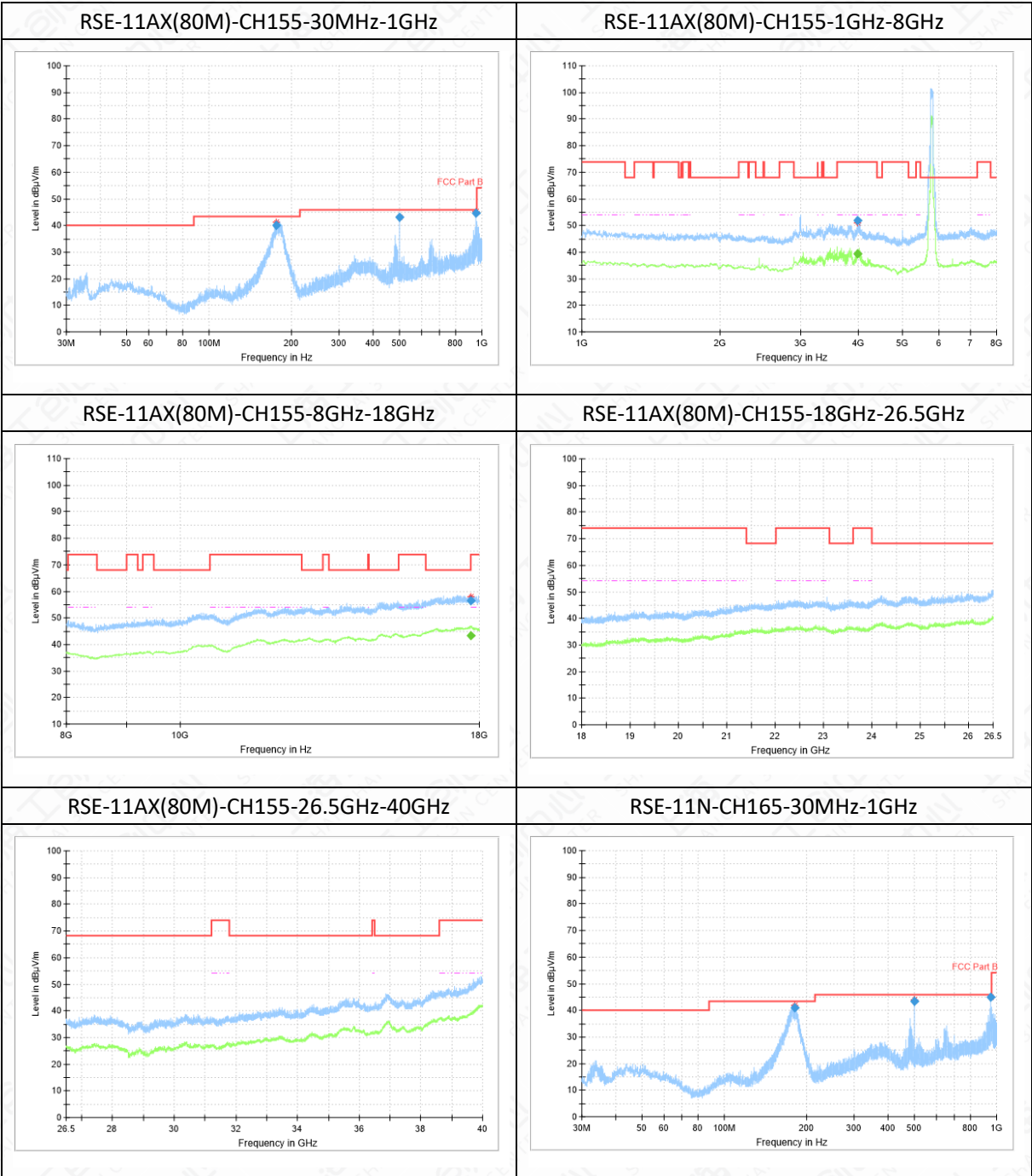



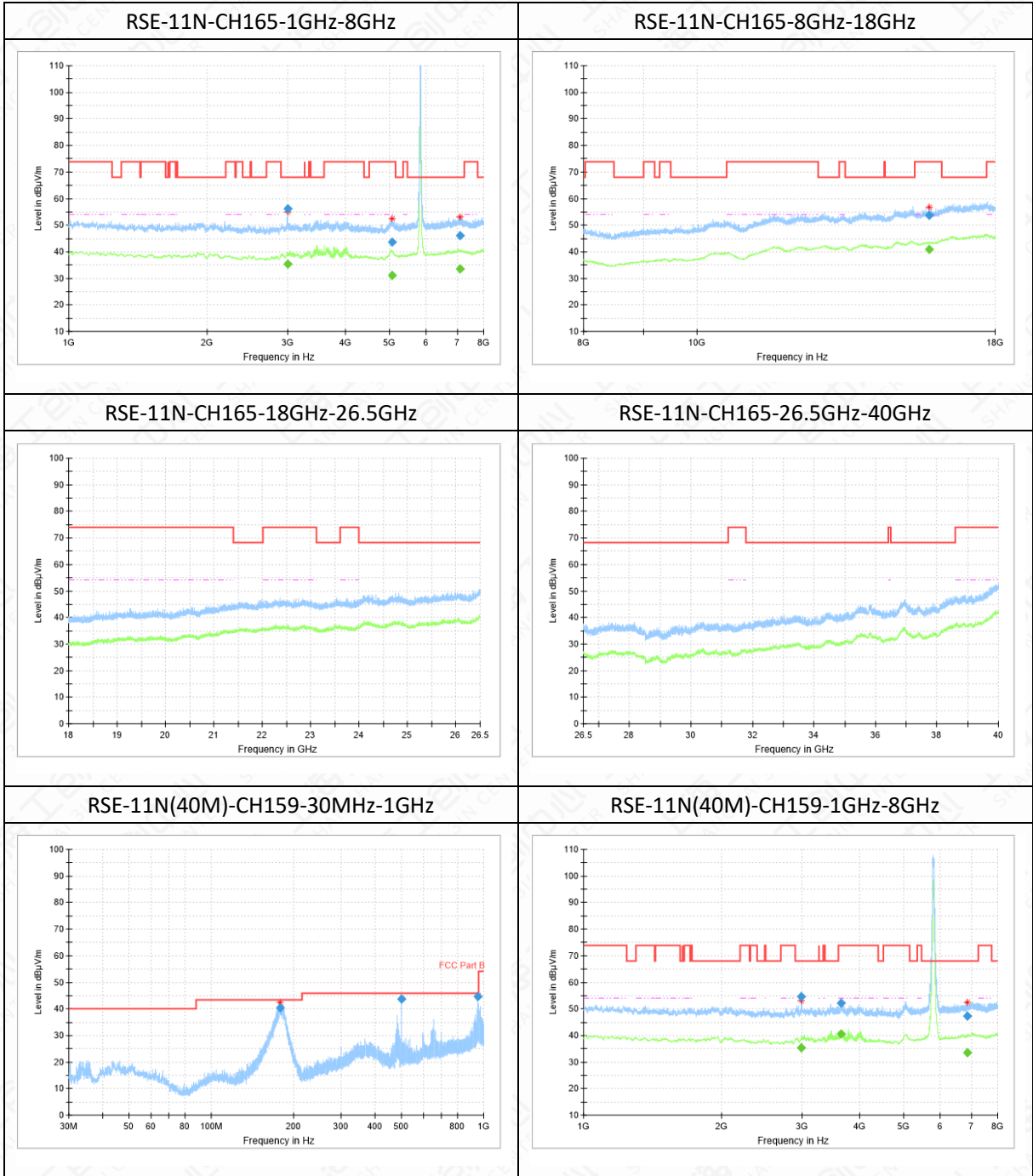

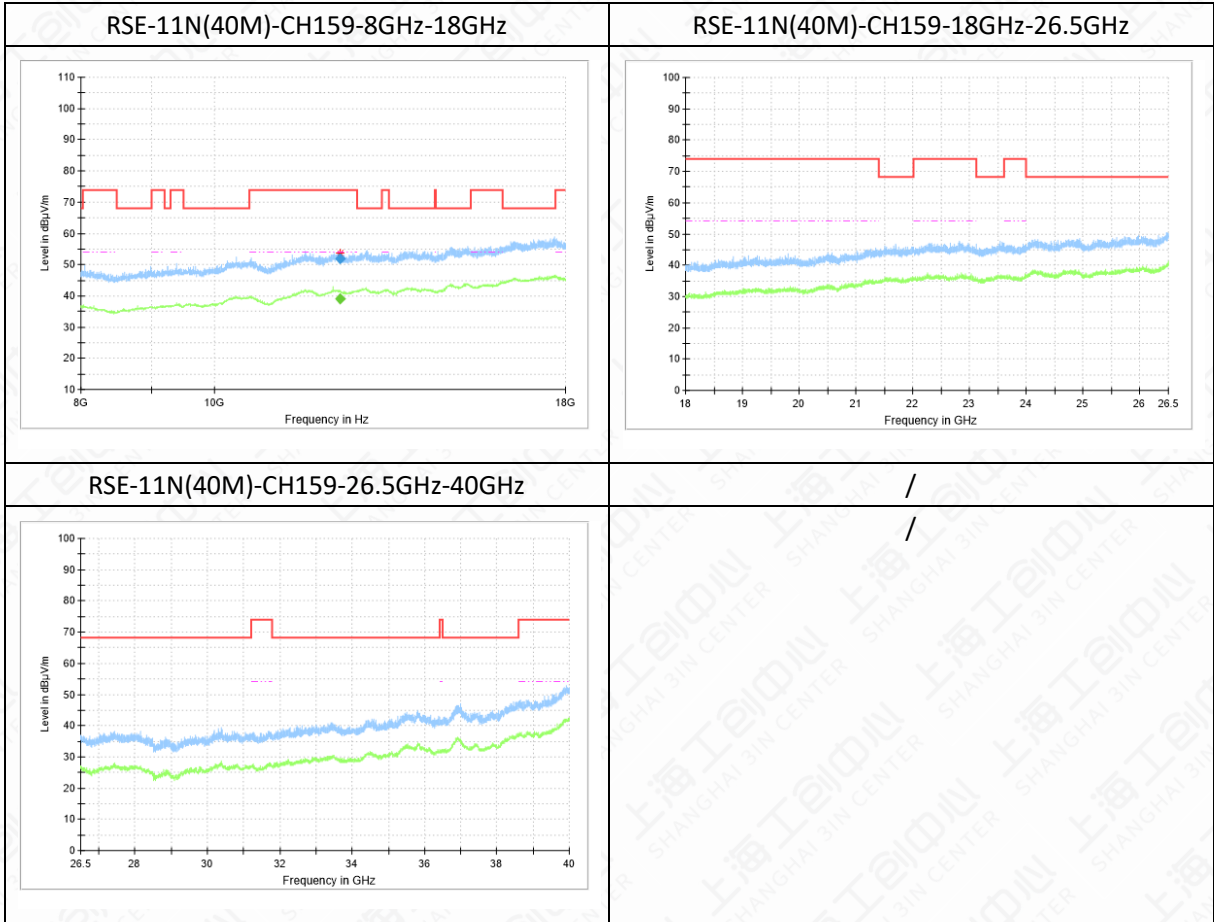

**Note:**

1. The out-of- limit signal in the picture is the main frequency signal.
2. Only data in worst mode is provided.
3. The test data below 30MHz is more than 20dB lower than the limit value, so it is not provided in the report.

## RSE-11AC-CH165-30MHz-1GHz

| Frequency (MHz) | QuasiPeak(dBμV/m) | ARpl (dB) | PMea (dBμV/m) | Margin(dB) | Limit(dBμV/m) | Polarity |
|-----------------|-------------------|-----------|---------------|------------|---------------|----------|
| 179.1           | 41.15             | -15       | 56.15         | 2.35       | 43.50         | H        |
| 500.0           | 42.86             | -6        | 48.86         | 3.14       | 46.00         | H        |
| 949.8           | 43.92             | 1         | 42.92         | 2.08       | 46.00         | H        |

## RSE-11AC-CH165-1GHz-8GHz

| Frequency (MHz) | MaxPeak(dBμV/m) | ARpl (dB) | PMea (dBμV/m) | Margin(dB) | Limit(dBμV/m) | Polarity |
|-----------------|-----------------|-----------|---------------|------------|---------------|----------|
| 2993.2          | 53.55           | 2         | 51.55         | 14.65      | 68.20         | V        |
| 7048.5          | 46.67           | 4         | 42.67         | 21.53      | 68.20         | H        |

## RSE-11AC-CH165-1GHz-8GHz

| Frequency (MHz) | Average(dBμV/m) | ARpl (dB) | PMea (dBμV/m) | Margin(dB) | Limit(dBμV/m) | Polarity |
|-----------------|-----------------|-----------|---------------|------------|---------------|----------|
| 2993.2          | 34.97           | 2         | 32.97         | ---        | ---           | V        |
| 7048.5          | 34.19           | 4         | 30.19         | ---        | ---           | H        |

## RSE-11AC-CH165-8GHz-18GHz

| Frequency (MHz) | MaxPeak(dBμV/m) | ARpl (dB) | PMea (dBμV/m) | Margin(dB) | Limit(dBμV/m) | Polarity |
|-----------------|-----------------|-----------|---------------|------------|---------------|----------|
| 17781.2         | 55.38           | 18        | 37.38         | 18.62      | 74.00         | H        |

## RSE-11AC-CH165-8GHz-18GHz

| Frequency (MHz) | Average(dBμV/m) | ARpl (dB) | PMea (dBμV/m) | Margin(dB) | Limit(dBμV/m) | Polarity |
|-----------------|-----------------|-----------|---------------|------------|---------------|----------|
| 17781.2         | 42.88           | 18        | 24.88         | 11.12      | 54.00         | H        |

## RSE-11AC(40M)-CH159-30MHz-1GHz

| Frequency (MHz) | QuasiPeak(dBμV/m) | ARpl (dB) | PMea (dBμV/m) | Margin(dB) | Limit(dBμV/m) | Polarity |
|-----------------|-------------------|-----------|---------------|------------|---------------|----------|
| 179.2           | 40.98             | -15       | 55.98         | 2.52       | 43.50         | H        |
| 500.0           | 42.96             | -6        | 48.96         | 3.04       | 46.00         | H        |
| 949.8           | 44.45             | 1         | 43.45         | 1.55       | 46.00         | H        |

## RSE-11AC(40M)-CH159-1GHz-8GHz

| Frequency (MHz) | MaxPeak(dBμV/m) | ARpl (dB) | PMea (dBμV/m) | Margin(dB) | Limit(dBμV/m) | Polarity |
|-----------------|-----------------|-----------|---------------|------------|---------------|----------|
| 2995.9          | 52.69           | 2         | 50.69         | 15.51      | 68.20         | V        |
| 3985.9          | 49.11           | 1         | 48.11         | 24.89      | 74.00         | H        |
| 7076.0          | 46.53           | 4         | 42.53         | 21.67      | 68.20         | H        |

## RSE-11AC(40M)-CH159-1GHz-8GHz

| Frequency (MHz) | Average(dBμV/m) | ARpl (dB) | PMea (dBμV/m) | Margin(dB) | Limit(dBμV/m) | Polarity |
|-----------------|-----------------|-----------|---------------|------------|---------------|----------|
| 2995.9          | 34.98           | 2         | 32.98         | ---        | ---           | V        |
| 3985.9          | 36.86           | 1         | 35.86         | 17.14      | 54.00         | H        |
| 7076.0          | 34.12           | 4         | 30.12         | ---        | ---           | H        |

## RSE-11AC(40M)-CH159-8GHz-18GHz

| Frequency (MHz) | MaxPeak(dBμV/m) | ARpl (dB) | PMea (dBμV/m) | Margin(dB) | Limit(dBμV/m) | Polarity |
|-----------------|-----------------|-----------|---------------|------------|---------------|----------|
| 12604.2         | 52.45           | 11        | 41.45         | 21.55      | 74.00         | V        |

## RSE-11AC(40M)-CH159-8GHz-18GHz

| Frequency (MHz) | Average(dBμV/m) | ARpl (dB) | PMea (dBμV/m) | Margin(dB) | Limit(dBμV/m) | Polarity |
|-----------------|-----------------|-----------|---------------|------------|---------------|----------|
| 12604.2         | 39.62           | 11        | 28.62         | 14.38      | 54.00         | V        |

## RSE-11AC(80M)-CH155-30MHz-1GHz

| Frequency (MHz) | QuasiPeak(dBμV/m) | ARpl (dB) | PMea (dBμV/m) | Margin(dB) | Limit(dBμV/m) | Polarity |
|-----------------|-------------------|-----------|---------------|------------|---------------|----------|
| 181.9           | 40.59             | -14       | 54.59         | 2.91       | 43.50         | H        |
| 500.0           | 43.04             | -6        | 49.04         | 2.96       | 46.00         | H        |
| 949.9           | 44.19             | 1         | 43.19         | 1.81       | 46.00         | H        |

## RSE-11AC(80M)-CH155-1GHz-8GHz

| Frequency (MHz) | MaxPeak(dBμV/m) | ARpl (dB) | PMea (dBμV/m) | Margin(dB) | Limit(dBμV/m) | Polarity |
|-----------------|-----------------|-----------|---------------|------------|---------------|----------|
| 2994.5          | 52.29           | 2         | 50.29         | 15.92      | 68.20         | V        |
| 3449.6          | 51.3            | 1         | 50.3          | 16.90      | 68.20         | V        |
| 7138.2          | 48.07           | 4         | 44.07         | 20.13      | 68.20         | V        |

## RSE-11AC(80M)-CH155-1GHz-8GHz

| Frequency (MHz) | Average(dBμV/m) | ARpl (dB) | PMea (dBμV/m) | Margin(dB) | Limit(dBμV/m) | Polarity |
|-----------------|-----------------|-----------|---------------|------------|---------------|----------|
| 2994.5          | 34.99           | 2         | 32.99         | ---        | ---           | V        |
| 3449.6          | 39.19           | 1         | 38.19         | ---        | ---           | V        |
| 7138.2          | 34.79           | 4         | 30.79         | ---        | ---           | V        |

## RSE-11AC(80M)-CH155-8GHz-18GHz

| Frequency (MHz) | MaxPeak(dBμV/m) | ARpl (dB) | PMea (dBμV/m) | Margin(dB) | Limit(dBμV/m) | Polarity |
|-----------------|-----------------|-----------|---------------|------------|---------------|----------|
| 11650.8         | 53.24           | 10        | 43.24         | 20.76      | 74.00         | V        |

## RSE-11AC(80M)-CH155-8GHz-18GHz

| Frequency (MHz) | Average(dBμV/m) | ARpl (dB) | PMea (dBμV/m) | Margin(dB) | Limit(dBμV/m) | Polarity |
|-----------------|-----------------|-----------|---------------|------------|---------------|----------|
| 11650.8         | 39.05           | 10        | 29.05         | 14.95      | 54.00         | V        |

## RSE-11A-CH157-30MHz-1GHz

| Frequency (MHz) | QuasiPeak(dBμV/m) | ARpl (dB) | PMea (dBμV/m) | Margin(dB) | Limit(dBμV/m) | Polarity |
|-----------------|-------------------|-----------|---------------|------------|---------------|----------|
| 180.3           | 40.73             | -14       | 54.73         | 2.77       | 43.50         | H        |
| 500.0           | 42.63             | -6        | 48.63         | 3.37       | 46.00         | H        |
| 949.8           | 44.54             | 1         | 43.54         | 1.46       | 46.00         | H        |

## RSE-11A-CH157-1GHz-8GHz

| Frequency (MHz) | MaxPeak(dBμV/m) | ARpl (dB) | PMea (dBμV/m) | Margin(dB) | Limit(dBμV/m) | Polarity |
|-----------------|-----------------|-----------|---------------|------------|---------------|----------|
| 2912.9          | 47.54           | 2         | 45.54         | 20.66      | 68.20         | H        |
| 4995.2          | 44.14           | 4         | 40.14         | 29.86      | 74.00         | H        |

## RSE-11A-CH157-1GHz-8GHz

| Frequency (MHz) | Average(dBμV/m) | ARpl (dB) | PMea (dBμV/m) | Margin(dB) | Limit(dBμV/m) | Polarity |
|-----------------|-----------------|-----------|---------------|------------|---------------|----------|
| 2912.9          | 33.87           | 2         | 31.87         | ---        | ---           | H        |
| 4995.2          | 31.78           | 4         | 27.78         | 22.22      | 54.00         | H        |

## RSE-11A-CH157-8GHz-18GHz

| Frequency (MHz) | MaxPeak(dBμV/m) | ARpl (dB) | PMea (dBμV/m) | Margin(dB) | Limit(dBμV/m) | Polarity |
|-----------------|-----------------|-----------|---------------|------------|---------------|----------|
| 10543.8         | 48.99           | 8         | 40.99         | 19.21      | 68.20         | V        |

## RSE-11A-CH157-8GHz-18GHz

| Frequency (MHz) | Average(dBμV/m) | ARpl (dB) | PMea (dBμV/m) | Margin(dB) | Limit(dBμV/m) | Polarity |
|-----------------|-----------------|-----------|---------------|------------|---------------|----------|
| 10543.8         | 36.48           | 8         | 28.48         | ---        | ---           | V        |

## RSE-11AX(40M)-CH151-30MHz-1GHz

| Frequency (MHz) | QuasiPeak(dBμV/m) | ARpl (dB) | PMea (dBμV/m) | Margin(dB) | Limit(dBμV/m) | Polarity |
|-----------------|-------------------|-----------|---------------|------------|---------------|----------|
| 179.2           | 40.92             | -15       | 55.92         | 2.58       | 43.50         | H        |
| 500.0           | 43.14             | -6        | 49.14         | 2.86       | 46.00         | H        |
| 949.8           | 43.32             | 1         | 42.32         | 2.68       | 46.00         | H        |

## RSE-11AX(40M)-CH151-1GHz-8GHz

| Frequency (MHz) | MaxPeak(dBμV/m) | ARpl (dB) | PMea (dBμV/m) | Margin(dB) | Limit(dBμV/m) | Polarity |
|-----------------|-----------------|-----------|---------------|------------|---------------|----------|
|-----------------|-----------------|-----------|---------------|------------|---------------|----------|

|        |       |   |       |       |       |   |
|--------|-------|---|-------|-------|-------|---|
| 1945.5 | 46.89 | 3 | 43.89 | 21.31 | 68.20 | V |
| 3826.2 | 50.4  | 2 | 48.4  | 23.60 | 74.00 | V |

## RSE-11AX(40M)-CH151-1GHz-8GHz

| Frequency (MHz) | Average(dBμV/m) | ARpl (dB) | PMea (dBμV/m) | Margin(dB) | Limit(dBμV/m) | Polarity |
|-----------------|-----------------|-----------|---------------|------------|---------------|----------|
| 1945.5          | 34.03           | 3         | 31.03         | ---        | ---           | V        |
| 3826.2          | 39.66           | 2         | 37.66         | 14.34      | 54.00         | V        |

## RSE-11AX(40M)-CH151-8GHz-18GHz

| Frequency (MHz) | MaxPeak(dBμV/m) | ARpl (dB) | PMea (dBμV/m) | Margin(dB) | Limit(dBμV/m) | Polarity |
|-----------------|-----------------|-----------|---------------|------------|---------------|----------|
| 17851.2         | 55.79           | 18        | 37.79         | 18.21      | 74.00         | H        |

## RSE-11AX(40M)-CH151-8GHz-18GHz

| Frequency (MHz) | Average(dBμV/m) | ARpl (dB) | PMea (dBμV/m) | Margin(dB) | Limit(dBμV/m) | Polarity |
|-----------------|-----------------|-----------|---------------|------------|---------------|----------|
| 17851.2         | 42.54           | 18        | 24.54         | 11.46      | 54.00         | H        |

## RSE-11AX(80M)-CH155-30MHz-1GHz

| Frequency (MHz) | QuasiPeak(dBμV/m) | ARpl (dB) | PMea (dBμV/m) | Margin(dB) | Limit(dBμV/m) | Polarity |
|-----------------|-------------------|-----------|---------------|------------|---------------|----------|
| 177.0           | 40.08             | -15       | 55.08         | 3.42       | 43.50         | H        |
| 500.0           | 43.02             | -6        | 49.02         | 2.98       | 46.00         | H        |
| 949.8           | 44.69             | 1         | 43.69         | 1.31       | 46.00         | H        |

## RSE-11AX(80M)-CH155-1GHz-8GHz

| Frequency (MHz) | MaxPeak(dBμV/m) | ARpl (dB) | PMea (dBμV/m) | Margin(dB) | Limit(dBμV/m) | Polarity |
|-----------------|-----------------|-----------|---------------|------------|---------------|----------|
| 3986.4          | 51.92           | 1         | 50.92         | 22.08      | 74.00         | V        |

## RSE-11AX(80M)-CH155-1GHz-8GHz

| Frequency (MHz) | Average(dBμV/m) | ARpl (dB) | PMea (dBμV/m) | Margin(dB) | Limit(dBμV/m) | Polarity |
|-----------------|-----------------|-----------|---------------|------------|---------------|----------|
| 3986.4          | 39.49           | 1         | 38.49         | 14.51      | 54.00         | V        |

## RSE-11AX(80M)-CH155-8GHz-18GHz

| Frequency (MHz) | MaxPeak(dBμV/m) | ARpl (dB) | PMea (dBμV/m) | Margin(dB) | Limit(dBμV/m) | Polarity |
|-----------------|-----------------|-----------|---------------|------------|---------------|----------|
| 17703.5         | 56.4            | 18        | 38.4          | 17.60      | 74.00         | V        |

## RSE-11AX(80M)-CH155-8GHz-18GHz

| Frequency (MHz) | Average(dBμV/m) | ARpl (dB) | PMea (dBμV/m) | Margin(dB) | Limit(dBμV/m) | Polarity |
|-----------------|-----------------|-----------|---------------|------------|---------------|----------|
| 17703.5         | 43.43           | 18        | 25.43         | 10.57      | 54.00         | V        |

## RSE-11AX-CH149-30MHz-1GHz

| Frequency (MHz) | QuasiPeak(dBμV/m) | ARpl (dB) | PMea (dBμV/m) | Margin(dB) | Limit(dBμV/m) | Polarity |
|-----------------|-------------------|-----------|---------------|------------|---------------|----------|
| 178.1           | 40.82             | -15       | 55.82         | 2.68       | 43.50         | H        |
| 500.0           | 43.09             | -6        | 49.09         | 2.91       | 46.00         | H        |
| 949.9           | 44.54             | 1         | 43.54         | 1.56       | 46.00         | H        |

## RSE-11AX-CH149-1GHz-8GHz

| Frequency (MHz) | MaxPeak(dBμV/m) | ARpl (dB) | PMea (dBμV/m) | Margin(dB) | Limit(dBμV/m) | Polarity |
|-----------------|-----------------|-----------|---------------|------------|---------------|----------|
| 3646.9          | 50.4            | 1         | 49.4          | 23.60      | 74.00         | H        |
| 5027.1          | 43.83           | 5         | 38.83         | 30.17      | 74.00         | H        |

## RSE-11AX-CH149-1GHz-8GHz

| Frequency (MHz) | Average(dBμV/m) | ARpl (dB) | PMea (dBμV/m) | Margin(dB) | Limit(dBμV/m) | Polarity |
|-----------------|-----------------|-----------|---------------|------------|---------------|----------|
| 3646.9          | 38.56           | 1         | 37.56         | 15.44      | 54.00         | H        |
| 5027.1          | 31.33           | 5         | 26.33         | 22.67      | 54.00         | H        |

## RSE-11AX-CH149-8GHz-18GHz

| Frequency (MHz) | MaxPeak(dBμV/m) | ARpl (dB) | PMea (dBμV/m) | Margin(dB) | Limit(dBμV/m) | Polarity |
|-----------------|-----------------|-----------|---------------|------------|---------------|----------|
| 11602.0         | 51.27           | 10        | 41.27         | 22.73      | 74.00         | V        |

## RSE-11AX-CH149-8GHz-18GHz

| Frequency (MHz) | Average(dBμV/m) | ARpl (dB) | PMea (dBμV/m) | Margin(dB) | Limit(dBμV/m) | Polarity |
|-----------------|-----------------|-----------|---------------|------------|---------------|----------|
| 11602.0         | 38.73           | 10        | 28.73         | 15.27      | 54.00         | V        |

## RSE-11N(40M)-CH159-30MHz-1GHz

| Frequency (MHz) | QuasiPeak(dBμV/m) | ARpl (dB) | PMea (dBμV/m) | Margin(dB) | Limit(dBμV/m) | Polarity |
|-----------------|-------------------|-----------|---------------|------------|---------------|----------|
| 179.1           | 40.34             | -15       | 55.34         | 3.16       | 43.50         | H        |
| 500.0           | 43.86             | -6        | 49.86         | 2.14       | 46.00         | H        |
| 949.8           | 44.76             | 1         | 43.76         | 1.24       | 46.00         | H        |

## RSE-11N(40M)-CH159-1GHz-8GHz

| Frequency (MHz) | MaxPeak(dBμV/m) | ARpl (dB) | PMea (dBμV/m) | Margin(dB) | Limit(dBμV/m) | Polarity |
|-----------------|-----------------|-----------|---------------|------------|---------------|----------|
| 2987.0          | 54.66           | 2         | 52.66         | 13.54      | 68.20         | V        |
| 3642.4          | 52.17           | 1         | 51.17         | 21.83      | 74.00         | H        |
| 6878.1          | 47.34           | 4         | 43.34         | 20.86      | 68.20         | H        |

**RSE-11N(40M)-CH159-1GHz-8GHz**

| Frequency (MHz) | Average(dBμV/m) | ARpl (dB) | PMea (dBμV/m) | Margin(dB) | Limit(dBμV/m) | Polarity |
|-----------------|-----------------|-----------|---------------|------------|---------------|----------|
| 2987.0          | 35.33           | 2         | 33.33         | ---        | ---           | V        |
| 3642.4          | 40.47           | 1         | 39.47         | 13.53      | 54.00         | H        |
| 6878.1          | 33.67           | 4         | 29.67         | ---        | ---           | H        |

**RSE-11N(40M)-CH159-8GHz-18GHz**

| Frequency (MHz) | MaxPeak(dBμV/m) | ARpl (dB) | PMea (dBμV/m) | Margin(dB) | Limit(dBμV/m) | Polarity |
|-----------------|-----------------|-----------|---------------|------------|---------------|----------|
| 12352.2         | 51.98           | 11        | 40.98         | 22.02      | 74.00         | V        |

**RSE-11N(40M)-CH159-8GHz-18GHz**

| Frequency (MHz) | Average(dBμV/m) | ARpl (dB) | PMea (dBμV/m) | Margin(dB) | Limit(dBμV/m) | Polarity |
|-----------------|-----------------|-----------|---------------|------------|---------------|----------|
| 12352.2         | 39.14           | 11        | 28.14         | 14.86      | 54.00         | V        |

**RSE-11N-CH165-30MHz-1GHz**

| Frequency (MHz) | QuasiPeak(dBμV/m) | ARpl (dB) | PMea (dBμV/m) | Margin(dB) | Limit(dBμV/m) | Polarity |
|-----------------|-------------------|-----------|---------------|------------|---------------|----------|
| 181.8           | 40.91             | -14       | 54.91         | 2.59       | 43.50         | H        |
| 500.0           | 43.45             | -6        | 49.45         | 2.55       | 46.00         | H        |
| 949.9           | 45                | 1         | 44            | 1.00       | 46.00         | H        |

**RSE-11N-CH165-1GHz-8GHz**

| Frequency (MHz) | MaxPeak(dBμV/m) | ARpl (dB) | PMea (dBμV/m) | Margin(dB) | Limit(dBμV/m) | Polarity |
|-----------------|-----------------|-----------|---------------|------------|---------------|----------|
| 2995.0          | 56.18           | 2         | 54.18         | 12.02      | 68.20         | V        |
| 5053.0          | 43.67           | 5         | 38.67         | 30.33      | 74.00         | H        |
| 7110.2          | 46.15           | 4         | 42.15         | 22.05      | 68.20         | H        |

**RSE-11N-CH165-1GHz-8GHz**

| Frequency (MHz) | Average(dBμV/m) | ARpl (dB) | PMea (dBμV/m) | Margin(dB) | Limit(dBμV/m) | Polarity |
|-----------------|-----------------|-----------|---------------|------------|---------------|----------|
| 2995.0          | 35.36           | 2         | 33.36         | ---        | ---           | V        |
| 5053.0          | 31.01           | 5         | 26.01         | 22.99      | 54.00         | H        |
| 7110.2          | 33.65           | 4         | 29.65         | ---        | ---           | H        |

**RSE-11N-CH165-8GHz-18GHz**

| Frequency (MHz) | MaxPeak(dBμV/m) | ARpl (dB) | PMea (dBμV/m) | Margin(dB) | Limit(dBμV/m) | Polarity |
|-----------------|-----------------|-----------|---------------|------------|---------------|----------|
| 15814.5         | 53.64           | 15        | 38.64         | 20.36      | 74.00         | V        |



## RSE-11N-CH165-8GHz-18GHz

| Frequency (MHz) | Average(dB $\mu$ V/m) | ARpl (dB) | PMea (dB $\mu$ V/m) | Margin(dB) | Limit(dB $\mu$ V/m) | Polarity |
|-----------------|-----------------------|-----------|---------------------|------------|---------------------|----------|
| 15814.5         | 40.75                 | 15        | 25.75               | 13.25      | 54.00               | V        |

## 6.8 Band Edges Compliance (Radiated)

### 6.8.1 Measurement Limit

#### Above 1G, non-restricted band

| Standard  | Limit             |
|-----------|-------------------|
| 15.407(b) | EIRP < -27dBm/MHz |

#### Above 1G, Restricted band

| Standard  | Limit             |          |
|-----------|-------------------|----------|
| 15.407(b) | EIRP < -27dBm/MHz |          |
| 15.209    | Peak              | 74dBμV/m |
|           | Average           | 54dBμV/m |

$$\text{EIRP[dBm]} = \text{E[dB}\mu\text{V/m]} + 20 \log(d[\text{m}]) - 104.7$$

$$\text{E[dB}\mu\text{V/m]} = \text{EIRP[dBm]} - 20 \log(d[\text{m}]) + 104.7$$

$$\text{E[dB}\mu\text{V/m]} = \text{EIRP[dBm]} + 95.2 = 68.2, \text{ for } d = 3\text{m}$$

### 6.8.2 Test Procedure

The measurement is made according to KDB 789033.

Marker-Delta Method: The marker-delta method, as described in ANSI C63.10, can be used to perform measurements of the radiated unwanted emissions level of emissions provided that the 99% occupied bandwidth of the fundamental is within 2 MHz of the authorized band-edge.

#### Procedure for peak unwanted emissions measurements above 1000 MHz

The procedure for peak unwanted emissions measurements above 1000 MHz is as follows:

- a) Follow the requirements in 12.7.4.
- b) Peak emission levels are measured by setting the instrument as follows:
  - 1) RBW = 1 MHz.
  - 2) VBW  $\geq [3 \times \text{RBW}]$ .
  - 3) Detector = peak.
  - 4) Sweep time = auto.
  - 5) Trace mode = max hold.
  - 6) Allow sweeps to continue until the trace stabilizes. Note that if the transmission is not continuous, then the time required for the trace to stabilize will increase by a factor of approximately  $1 / D$ , where  $D$  is the duty cycle. For example, at 50% duty cycle, the measurement time will increase by a factor of two, relative to measurement time for continuous transmission.

#### Procedures for average unwanted emissions measurements above 1000 MHz

- a) RBW = 1 MHz.
- b) Video bandwidth:
  - 1) If the EUT is configured to transmit with  $D \geq 98\%$ , then set  $\text{VBW} \leq \text{RBW} / 100$  (i.e., 10 kHz), but not less than 10 Hz.
  - 2) If the EUT  $D$  is  $< 98\%$ , then set  $\text{VBW} \geq 1 / T$ , where  $T$  is defined in item a1) of 12.2.
- c) Video bandwidth mode or display mode:

- 1) The instrument shall be set with video filtering applied in the power domain. Typically, this requires setting the detector mode to RMS (power averaging) and setting the average-VBW type to power (rms).
- 2) As an alternative, the instrument may be set to linear detector mode. Video filtering shall be applied in linear voltage domain (rather than in a log or dB domain). Some instruments require linear display mode to accomplish this. Others have a setting for average-VBW type, which can be set to "voltage" regardless of the display mode.

d) Detector = peak.

e) Sweep time = auto.

f) Trace mode = max hold.

g) Allow max hold to run for at least 50 traces if the transmitted signal is continuous or has at least 98% duty cycle. For lower duty cycles, increase the minimum number of traces by a factor of  $1/x$ , where  $D$  is the duty cycle. For example, use at least 200 traces if the duty cycle is 25%. (If a specific emission is demonstrated to be continuous—i.e., 100% duty cycle—then rather than turning ON and OFF with the transmit cycle, at least 50 traces should be averaged.)

The measurement was applied in a fully anechoic chamber. While testing for spurious emission higher than 1GHz, if applied, the pre-amplifier would be equipped just at the output terminal of the antenna. Tabletop devices shall be placed on a nonconducting platform with nominal top surface dimensions 1 m by 1.5 m. For emission measurements above 1 GHz, the table height shall be 1.5 m. The turntable rotated 360 degrees to determine the position of the maximum emission level. The EUT was set 3 meters away from the receiving antenna which was mounted on an antenna mast. During the tests, the antenna height varied from 1m to 4m and the EUT azimuth were varied from 0° to 360° in order to identify the maximum level of emissions from the EUT. In making any tests involving handheld, body-worn, or ceiling-mounted equipment, it is essential to recognize that the measured levels may be dependent on the orientation (attitude) of the three orthogonal axes of the EUT. Thus, exploratory tests as specified in 8.3.1 shall be carried out for various axes orientations to determine the attitude having maximum or near-maximum emission level. This maximization process was repeated with the EUT positioned in each of its three orthogonal orientations.

### 6.8.3 Test Setup

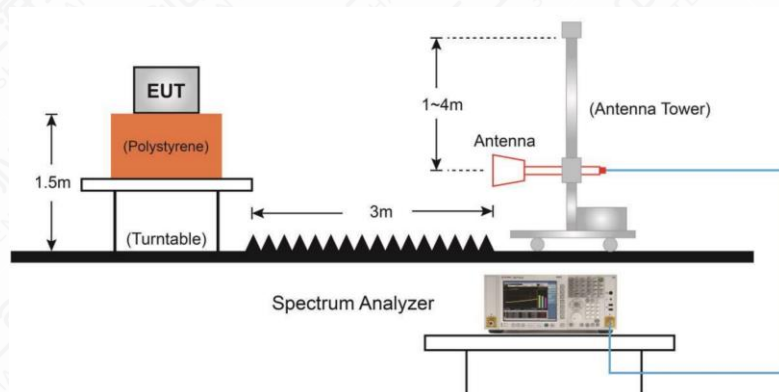

### 6.8.4 Measurement Result

| Mode    | Channel | Conclusion |
|---------|---------|------------|
| 802.11a | 149     | P          |

|                |     |   |
|----------------|-----|---|
|                | 165 | P |
| 802.11n HT20   | 149 | P |
|                | 165 | P |
| 802.11n HT40   | 151 | P |
|                | 159 | P |
| 802.11ac VHT20 | 149 | P |
|                | 165 | P |
| 802.11ac VHT40 | 151 | P |
|                | 159 | P |
| 802.11ac VHT80 | 155 | P |
| 802.11ax VHT20 | 149 | P |
|                | 165 | P |
| 802.11ax VHT40 | 151 | P |
|                | 159 | P |
| 802.11ax VHT80 | 155 | P |

Test graphs as below:

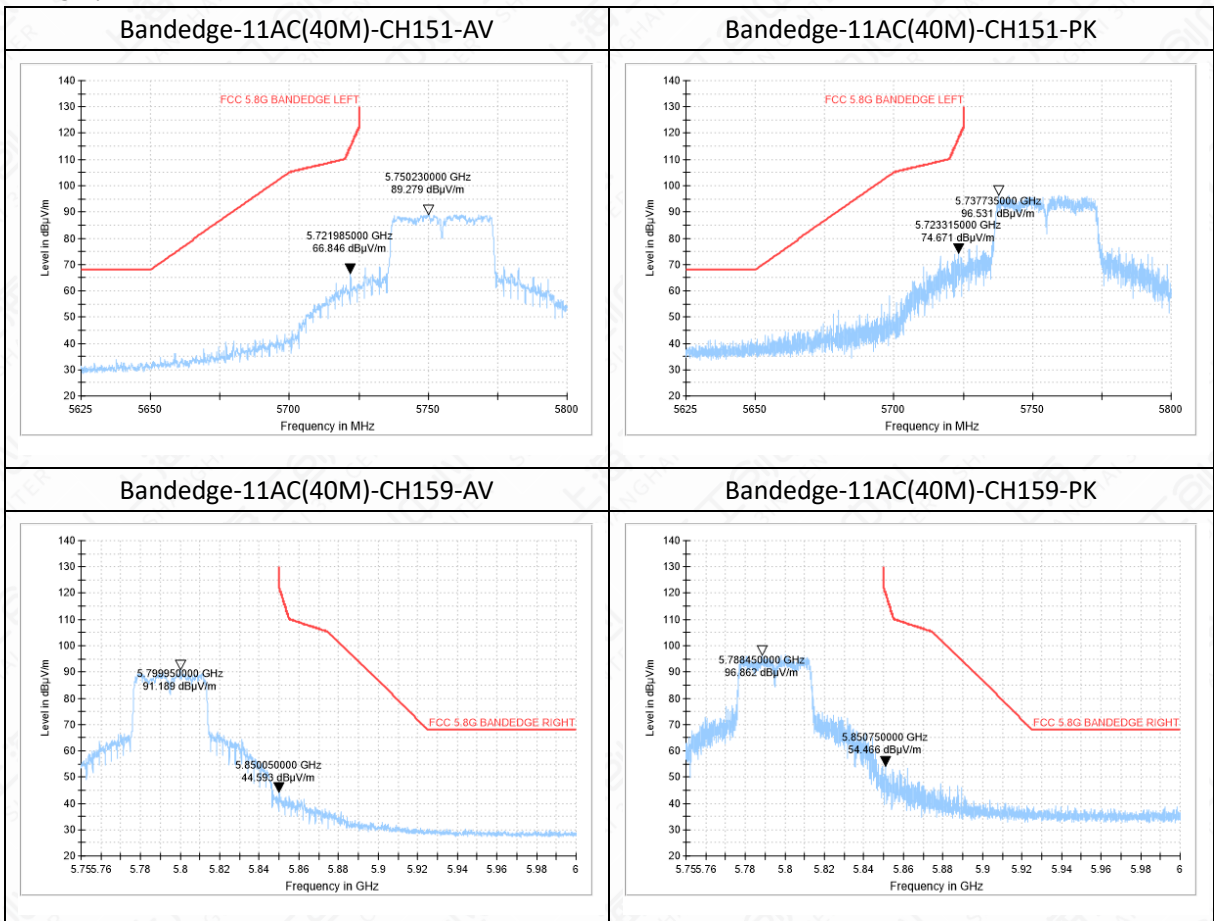

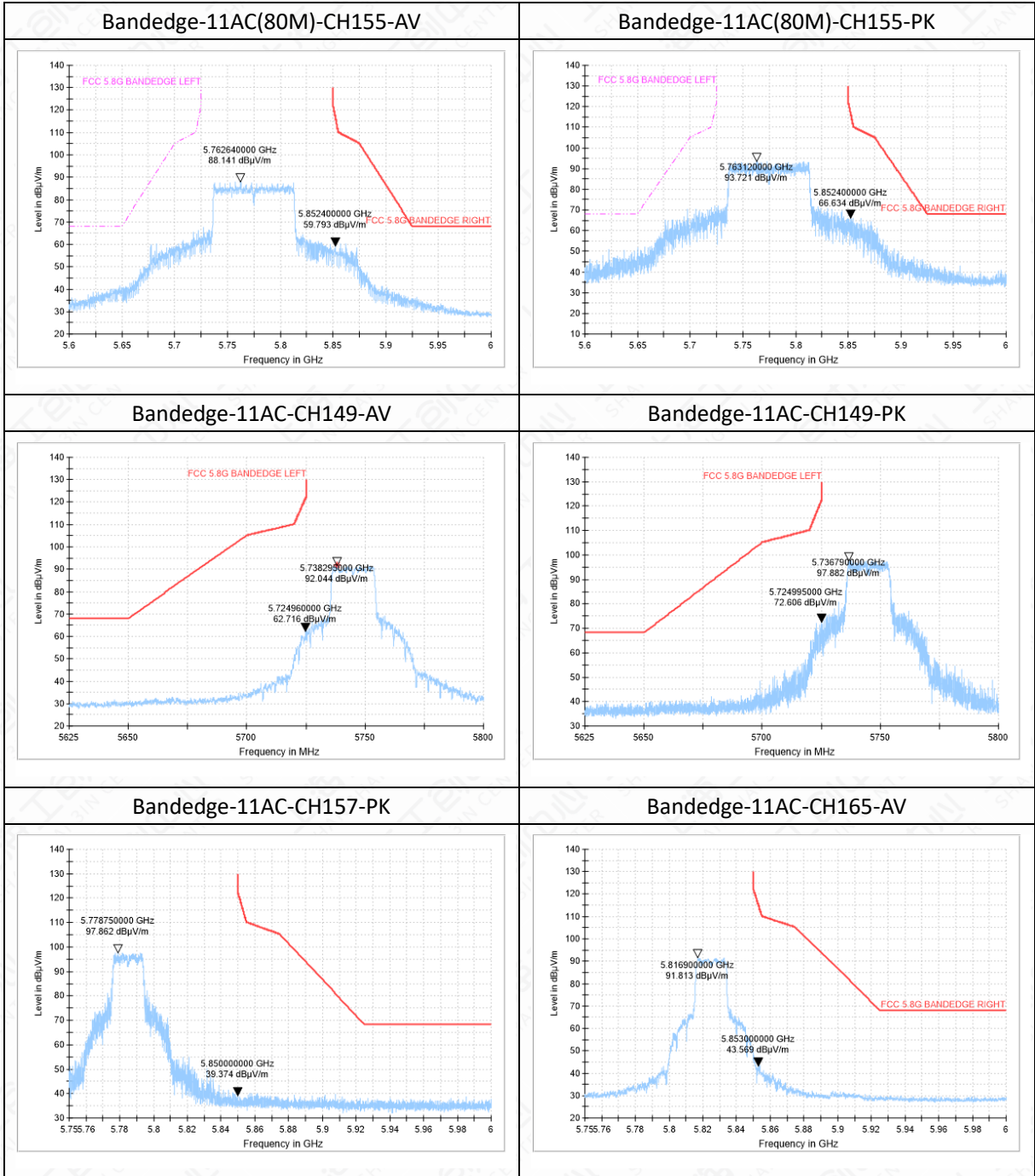

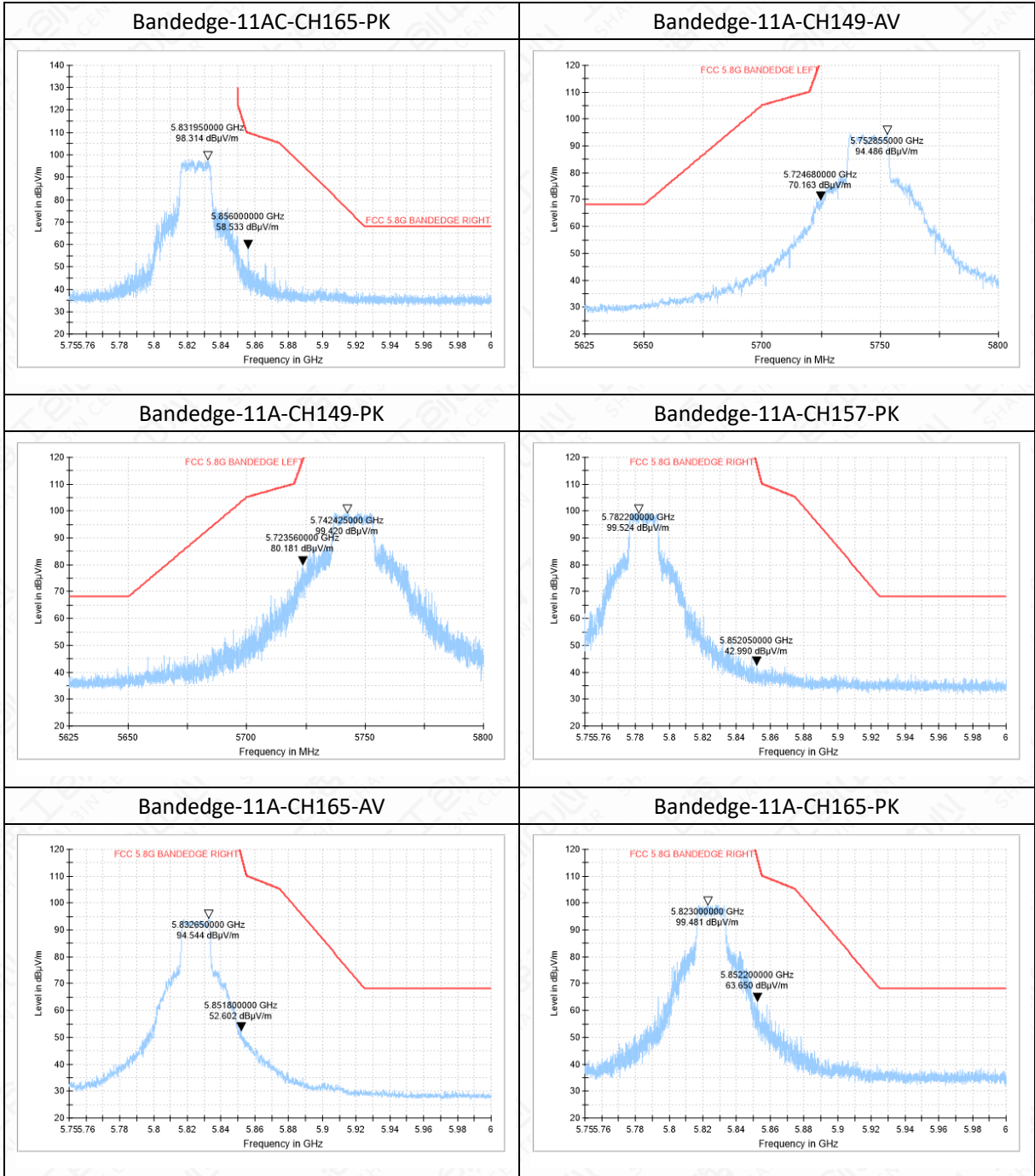

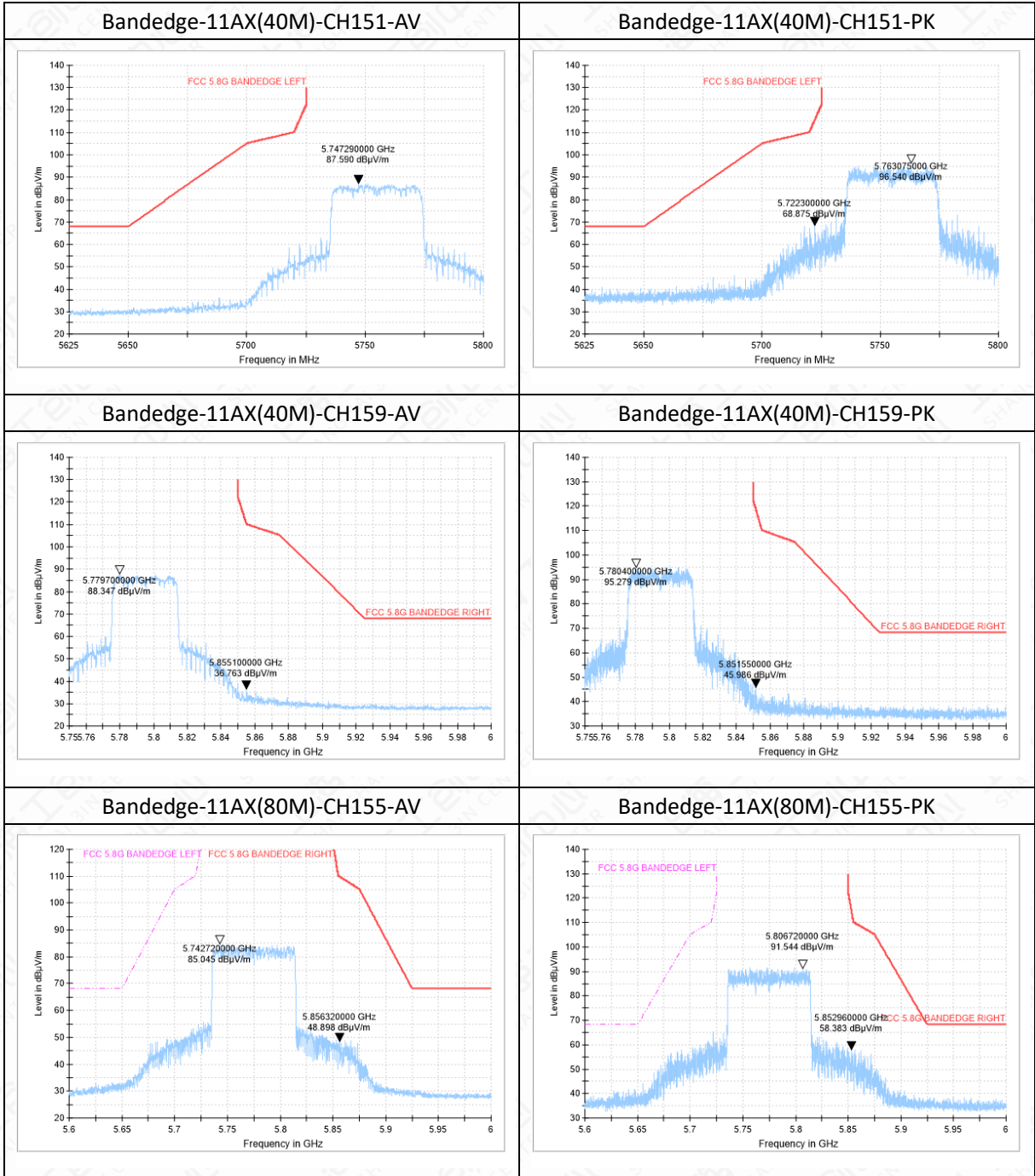

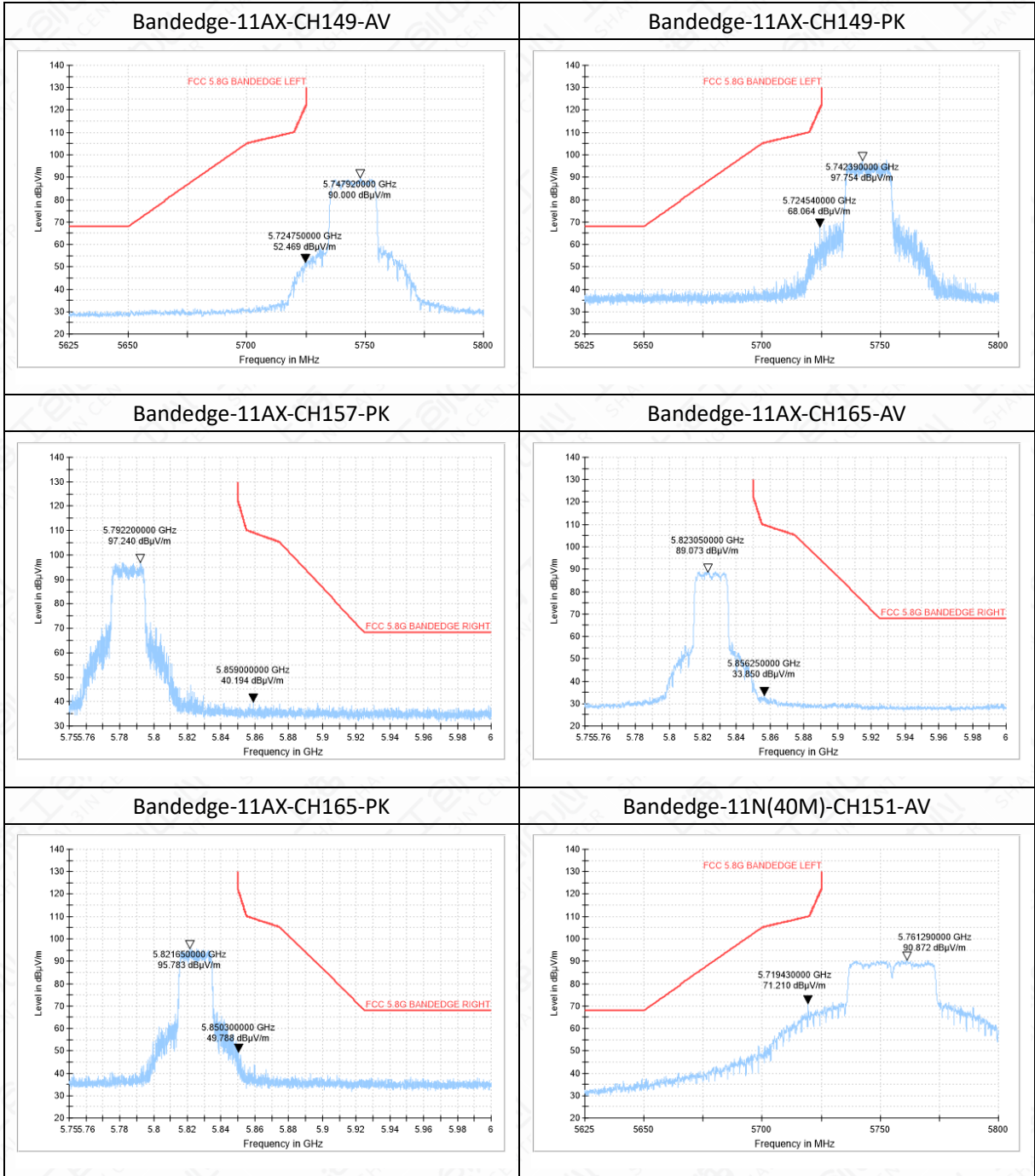



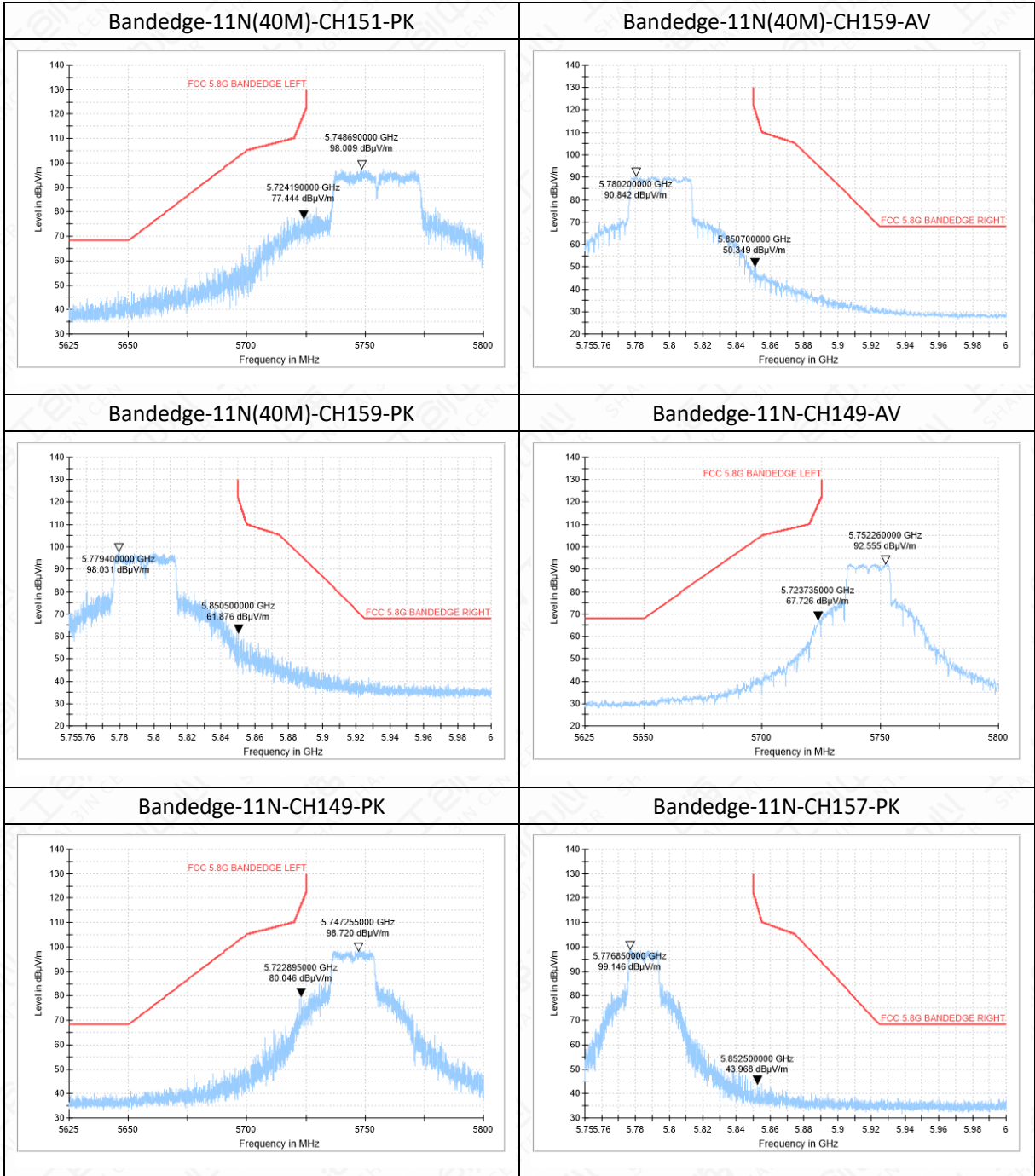

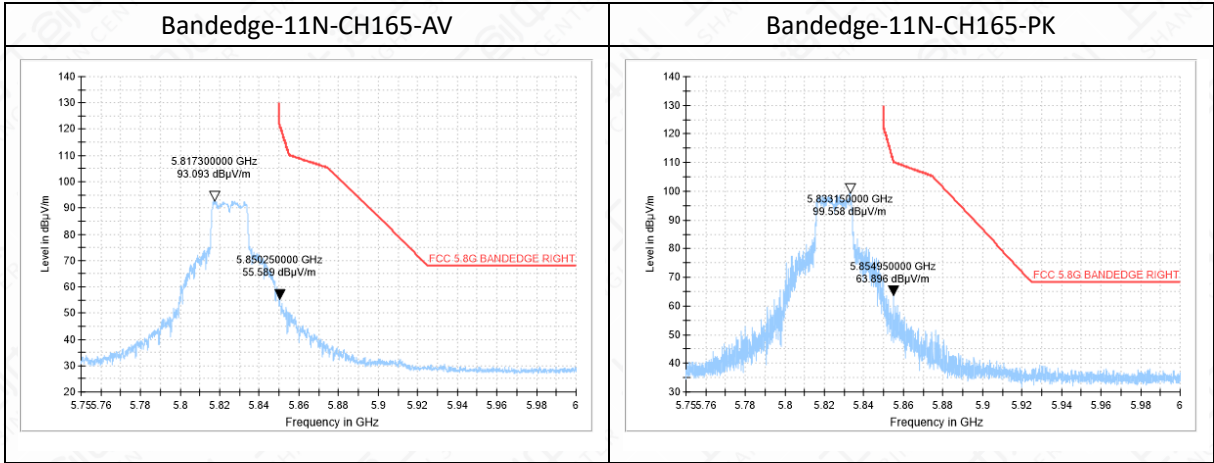

Note: Only data in worst mode is provided.

## 6.9 AC Powerline Conducted Emission

### 6.9.1 Method of Measurement: ANSI C63.10-2013-clause 6.2

1. The one EUT cable configuration and arrangement and mode of operation that produced the emission with the highest amplitude relative to the limit is selected for the final measurement, while applying the appropriate modulating signal to the EUT.
2. If the EUT is relocated from an exploratory test site to a final test site, the highest emissions shall be remaximized at the final test location before final ac power-line conducted emission measurements are performed.
3. The final test on all current-carrying conductors of all of the power cords to the equipment that comprises the EUT (but not the cords associated with other non-EUT equipment in the system) is then performed for the full frequency range for which the EUT is being tested for compliance without further variation of the EUT arrangement, cable positions, or EUT mode of operation.
4. If the EUT is comprised of equipment units that have their own separate ac power connections, e.g., floor-standing equipment with independent power cords for each shelf that are able to connect directly to the ac power network, each current-carrying conductor of one unit is measured while the other units are connected to a second (or more) LISN(s). All units shall be separately measured. If a power strip is provided by the manufacturer, to supply all of the units making up the EUT, only the conductors in the power cord of the power strip shall be measured.

If the EUT uses a detachable antenna, these measurements shall be made with a suitable dummy load connected to the antenna output terminals; otherwise, the tests shall be made with the antenna connected and, if adjustable, fully extended. When measuring the ac conducted emissions from a device that operates between 150 kHz and 30 MHz a non-detachable antenna may be replaced with a dummy load for the measurements within the fundamental emission band of the transmitter, but only for those measurements.<sup>36</sup> Record the six highest EUT emissions relative to the limit of each of the current-carrying conductors of the power cords of the equipment that comprises the EUT over the frequency range specified by the procuring or regulatory agency. Diagram or photograph the test setup that was used. See Clause 8 for full reporting requirements.

6.9.2 Test Setup

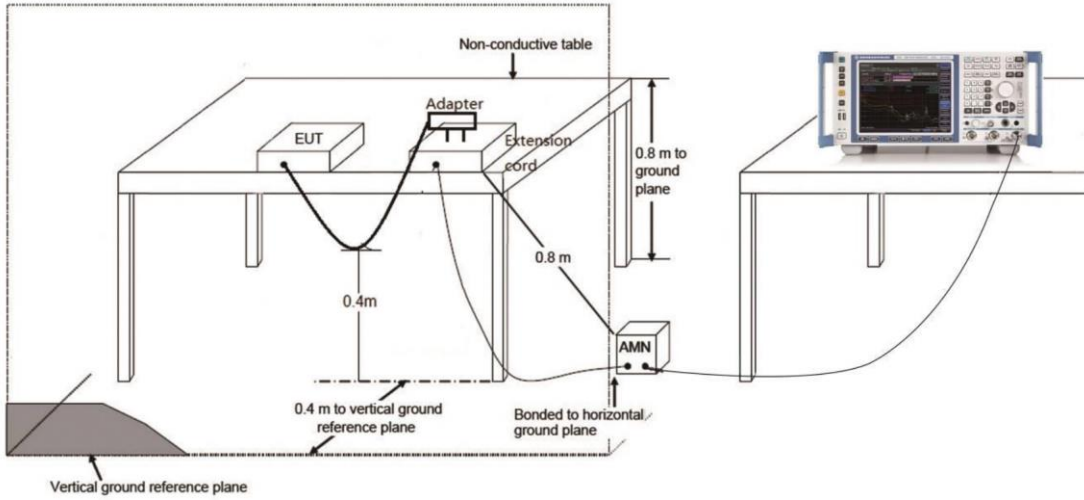

6.9.3 Test Condition

|             |                |
|-------------|----------------|
| Voltage (V) | Frequency (Hz) |
| 120         | 60             |

6.9.4 Measurement limit

(Quasi-peak-average Limit)

| Frequency range (MHz) | Quasi-peak Limit (dB $\mu$ V) | Average Limit (dB $\mu$ V) | Conclusion |
|-----------------------|-------------------------------|----------------------------|------------|
| 0.15 to 0.5           | 66 to 56                      | 56 to 46                   | P          |
| 0.5 to 5              | 56                            | 46                         |            |
| 5 to 30               | 60                            | 50                         |            |

NOTE: The limit decreases linearly with the logarithm of the frequency in the range 0.15 MHz to 0.5 MHz.

## 6.9.5 Measurement Result

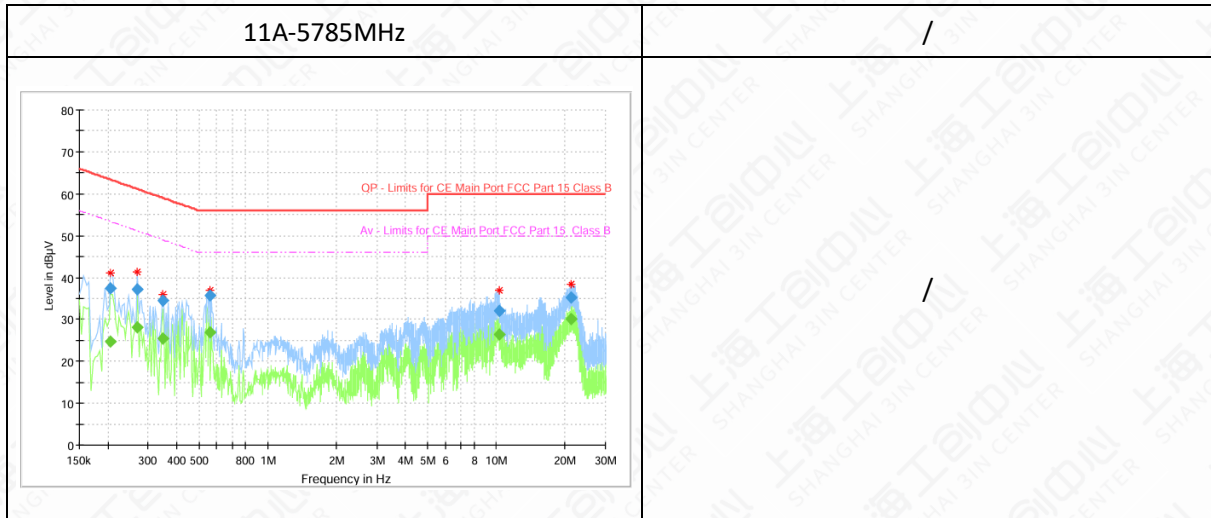

| Frequency (MHz) | QuasiPeak (dBµV) | Average (dBµV) | Limit (dBµV) | Margin (dB) | Meas. Time (ms) | Bandwidth (kHz) | Line | Filter | Corr. (dB) |
|-----------------|------------------|----------------|--------------|-------------|-----------------|-----------------|------|--------|------------|
| 0.205969        | 37.41            | ---            | 63.37        | 25.96       | 15000.0         | 9.000           | N    | ON     | 5.7        |
| 0.205969        | ---              | 24.79          | 53.37        | 28.57       | 15000.0         | 9.000           | N    | ON     | 5.7        |
| 0.269400        | 37.12            | ---            | 61.14        | 24.02       | 15000.0         | 9.000           | N    | ON     | 6.9        |
| 0.269400        | ---              | 28.14          | 51.14        | 22.99       | 15000.0         | 9.000           | N    | ON     | 6.9        |
| 0.347756        | 34.58            | ---            | 59.02        | 24.44       | 15000.0         | 9.000           | N    | ON     | 8.0        |
| 0.347756        | ---              | 25.50          | 49.02        | 23.51       | 15000.0         | 9.000           | N    | ON     | 8.0        |
| 0.556706        | 35.76            | ---            | 56.00        | 20.24       | 15000.0         | 9.000           | N    | ON     | 9.6        |
| 0.556706        | ---              | 26.99          | 46.00        | 19.01       | 15000.0         | 9.000           | N    | ON     | 9.6        |
| 10.295269       | ---              | 26.52          | 50.00        | 23.48       | 15000.0         | 9.000           | L1   | ON     | 9.8        |
| 10.295269       | 32.16            | ---            | 60.00        | 27.84       | 15000.0         | 9.000           | L1   | ON     | 9.8        |
| 21.197981       | ---              | 30.08          | 50.00        | 19.92       | 15000.0         | 9.000           | L1   | ON     | 10.0       |
| 21.197981       | 35.15            | ---            | 60.00        | 24.85       | 15000.0         | 9.000           | L1   | ON     | 10.0       |

Note: All modes have been tested and only the worst mode is recorded in the report.

**Annex A: Revised History**

| Version | Revised Content |
|---------|-----------------|
| V00     | Initial         |

Annex B: Accreditation Certificate



**Accredited Laboratory**

A2LA has accredited

**INDUSTRIAL INTERNET INNOVATION CENTER  
(SHANGHAI) CO., LTD.**  
*Shanghai, People's Republic of China*

for technical competence in the field of

**Electrical Testing**

This laboratory is accredited in accordance with the recognized International Standard ISO/IEC 17025:2017 *General requirements for the competence of testing and calibration laboratories*. This accreditation demonstrates technical competence for a defined scope and the operation of a laboratory quality management system (refer to joint ISO-ILAC-IAF Communiqué dated April 2017).



Presented this 20<sup>th</sup> day of September 2023.



Mr. Trace McInturff, Vice President, Accreditation Services  
For the Accreditation Council  
Certificate Number 3682.01  
Valid to February 28, 2025

*For the tests to which this accreditation applies, please refer to the laboratory's Electrical Scope of Accreditation.*

END OF REPORT