

Design Specification
Model: UPA-US

1.0 INTERFACE REQUIREMENTS

1.1 HARDWARE BLOCK DIAGRAM

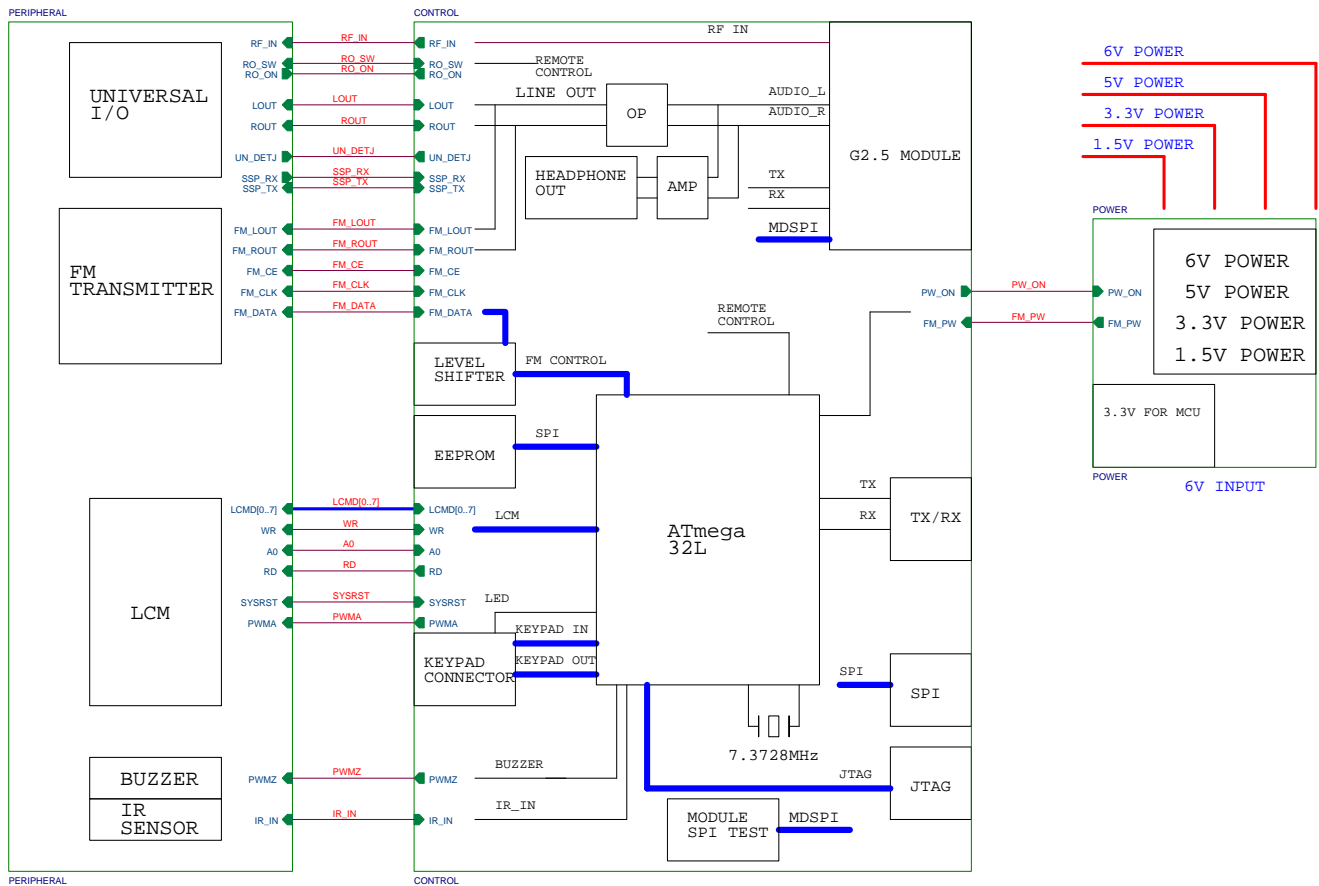

1.2 INPUT INTERFACE

- **Input power supply**

The UPA-US work on 6V~7VDC input, and maximum current less 1.5A. Ripple Noise less 100mVp-p

- **Input RF signal**

Power Level: -95dBm~ +5dBm

Frequency: 2.3~2.4G

Modulation: QPSK

- **IR remote Control**

Distance: 3m

Frequency: 38K

1.3 OUTPUT INTERFACE

- **Audio Line out**

Audio Level: 0~-9dB

Quality: Must meet RX55 specification

- **Audio Earphone out**

Audio Level: 0~-9dB

- **FM transmitter**

Frequency: 88.1~107.9MHz

Quality: Must meet RX57 specification

SOFTWARE/firmware REQUIREMENTS

1.4 CPU/MIPS SPECIFICATION

The firmware shall operate on an Atmega32 8-bit micro-controller running at a clock of at least 7MHz.

1.5 OS REQUIREMENT

The firmware shall operate without OS. A proprietary task switching mechanism will be implemented, instead.

1.6 MEMORY REQUIREMENT

The firmware shall require no more than 32KB program memory and no more than 2KB data memory. No more than 1KB of EEPROM shall be needed for power-off parameter storage.

1.7 USER INTERFACE REQUIREMENT

The product shall provide an user interface similar to JVC PnP XXX whenever possible. The operational menu tree is described in document XXX.....[more descriptions about UI]

1.8 PROTOCOL REQUIREMENT

The CPU of this product communicates with SSM module with SSP protocol. The firmware consists of SSP API provided by Sirius. The infrared remote control signal is a NEC repeat-pulse protocol. [more description about communication protocols]

2.0 PERFORMANCE REQUIREMENTS

2.1 BASELINE BER TESTING

- COFDM:

CNR: 9dB
 Power Level: -77dBm
 Test Period: 15 seconds
 Test Criteria: 5E-2 max

- CNR: 7.5dB

Power Level: -74.5dBm
 Test Period: 15 seconds
 Test Criteria: 8E-2 max

- TDM1 & TDM2:

CNR: 10dB
 Power Level: -74dBm
 Test Period: 15 second
 Test Criteria: 5E-2 max

- CNR: 6.4dB
 Power Level: -78dBm
 Test Period: 15 second
 Test Criteria: 8E-2 max

2.2 BER VS. CNR TEST

- COFDM:

Power level: -60, -65, -70dBm
 Test Period: 15 second
 Test Criteria: Refer Table

Table COFDM vs. CNR Limit

CNR (dB)	COFDM BER Limit
6	2.0E-1
7	1.5E-1
8	1.0E-1
9	6.5E-2
10	3.5E-2
11	2.0E-2
12	9.5E-3
13	4.0E-3
14	1.5E-3
15	5.0E-4
16	2.0E-4
17	6.0E-5
18	1.5E-5
19	1.0E-5
20	5.0E-6

- TDM1 & TDM2:

Power Level: -60, -65, 70dBm
 Test Period: 15 second
 Test Criteria: Refer table

Table TDM BER vs. CNR Limits

CNR (dB)	TDM BER Limits
4	1.3E-1
5	9.2E-2
6	5.6E-2
7	3.1E-2
8	1.5E-2
9	7.0E-3
10	2.5E-3

11	7.5E-4
12	1.8E-4
13	4.9E-5
14	7.2E-6
15	1.4E-6

2.3 BER PERFORMANCE- INPUT AMPLITUDE DYNAMIC RANGE

- COFDM: Noise: 15.75dB at -85dBm
 20.75dB at -80dBm
 -75~+4dBm noise off
 Power Level: 5dB step from -85dBm to +4dBm
 Test Period: 15 second
 Test Criteria: 5E-2 max
- TDM1 & TDM2 Noise: 11.75dB at -89dBm
 15.75dB at -85dBm
 20.75dB at -80dBm
 -75~-55dBm noise off
 Power Level: 5dB step form -89dBm to -55dBm
 Test Period: 15 second
 Test Criteria: 5E-2

2.4 BER PERFORMANCE- INPUT FREQUENCY DYNAMIC RANGE (DOPPLER SHIFT)

- COFDM: CNR: 9dB
 Power Level: -77dBm
 Frequency: a. 2326.25MHz to 2326.2495MHz.
 b. 2326.25MHz to 2326.2505MHz
 Test Period: 15 second
 Test Criteria: 5E-2
- TDM1 & TDM2: CNR: 10dBm
 Power Level: -74dBm
 Frequency: a. 2322.293MHz to 2322.255MHz
 b. 2322.293 MHz to 2322.331MHz
 Test Period: 15 second
 Test Criteria: 5E-2

2.5 BER PERFORMANCE - OUT OF BAND INTERFERENCE

- COFDM: CNR: 17.9dB
 Power Level: -67dBm
 Test Criteria: 5E-2
- TDM1 & TDM2: CNR: 10.4dBm
 Power Level: -71dBm
 Test Period: 15 second
 Test Criteria: 5E-2

Out of band interference table

Frequency (MHz)	Amplitude at TDM port of DLP (dBm)	Amplitude at COFDM port of DLP (dBm)
837(CW)	-23	-28
915(CW)	-23	-28
1990(IS95 MOD)	-23	-28
2338.75(XM MOD)	-35	-44
2400(CW)	-21	-32

2.6 BER PERFORMANCE - COFDM AGC TEST

- COFDM: Setup refer to Sirius document RX000055 page 48~49
 Test Criteria: >178dB/Sec

2.7 BER PERFORMANCE-XM INTERFERENCE TEST W/LNA

- TDM1 & TDM2: Setup refer to Sirius document RX000055 page 50~52
Test Criteria: >-29dBm

2.8 AUDIO PERFORMANCE-THDPN

The total harmonic distortion plus noise for each channel must less than 0.2% for 1KHz -2dB input.

2.9 AUDIO PERFORMANCE-SNR

SNR in each channel must be greater than 80 dB.

2.10 AUDIO PERFORMANCE-FREQUENCY RESPONSE

Test Setup refers RX55 section 8.6

For 14.5 kHz, the result must be in the window of [-1.7 dB to + 0.3 dB] for both left and right channels
[7.25 kHz = 0 dB].

For 14.8 kHz, the result must be in the window of [-6.5 dB to +0.0 dB] for both left and right channels
[7.25 kHz = 0 dB].

For 20 Hz, the result must be in the window of [-3.0 dB to +3.0 dB] for both left and right channels
[7.25 kHz = 0 dB].

2.11 AUDIO PERFORMANCE-FREQUENCY RESPONSE

Test Setup refers RX55 section 8.6

For 100Hz, the result must be in the window of [-1.0 dB to + 1.0 dB] for both left and right channels
[7.2kHz = 0 dB].

For 300Hz, the result must be in the window of [-1.0 dB to + 1.0 dB] for both left and right channels
[7.2kHz = 0 dB].

For 500Hz, the result must be in the window of [-1.0 dB to + 1.0 dB] for both left and right channels
[7.2kHz = 0 dB].

For 1kHz, the result must be in the window of [-1.0 dB to + 1.0 dB] for both left and right channels
[7.2kHz = 0 dB].

For 2kHz, the result must be in the window of [-1.0 dB to + 1.0 dB] for both left and right channels
[7.2kHz = 0 dB].

For 4kHz, the result must be in the window of [-1.0 dB to + 1.0 dB] for both left and right channels
[7.2kHz = 0 dB].

For 12k Hz, the result must be in the window of [-1.0 dB to + 1.0 dB] for both left and right channels
[7.2kHz = 0 dB].

2.12 FM-MODULATED AUDIO MODULATION LEVEL

Test Setup refers RX57 section 5.1

For Stream 223, the waveform is stable 0.5 seconds after periodic silence at -10dBFS, 1KHz L+R Sine wave.
Bandwidth 20~20KHZ

Modulation Level: 48~72%

For Stream 184, the waveform is stable 4 seconds after periodic silence at -2.97dBFS, 1KHz L+R Sine wave.
Bandwidth 20~20KHZ

Modulation Level: >100%

2.13 FM-MODULATED AUDIO TOTAL HARMONIC DISTORTION PLUS NOISE

Test Setup refers RX57 section 5.2

For Stream 223, the waveform is stable 0.5 seconds after periodic silence at -10dBFS, 1KHz L+R Sine wave.
Bandwidth 20~20KHZ

THD+N: <1%

For Stream 184, the waveform is stable 4 seconds after periodic silence at -2.97dBFS, 1KHz L+R Sine wave.
Bandwidth 20~20KHZ

THD+N: <2%

2.14 FM-MODULATED AUDIO CHANNEL BALANCE

Test Setup refers RX57 section 5.3

For Stream 211, the waveform is stable 3 seconds after periodic silence at -5.13dBFS, 1KHz L+R Sine wave.
Bandwidth 20~20KHZ
±1.5dB

2.15 FM-MODULATED AUDIO SIGNAL TO NOISE

Test Setup refers RX57 section 5.4

For Stream 223, the waveform is stable 0.5 seconds after periodic silence at -10dBFS, 1KHz L+R Sine wave.
Bandwidth 20~20KHZ
For Stream 204, the waveform is digital silence.
Bandwidth 20~20KHZ
SNR >50dB

2.16 FM-MODULATED AUDIO MULTI-TONE TESTING

Test Setup refers RX57 section 5.5

For Stream 206, the waveform is stable 1 seconds after periodic silence.
Bandwidth 20~20KHZ

For Stream 207, the waveform is stable 1 seconds after periodic silence.
Bandwidth 20~20KHZ

For Stream 208, the waveform is stable 1 seconds after periodic silence.
Bandwidth 20~20KHZ

Stream #	206		207		208	
Frequency	Left	Right	Left	Right	Left	Right
20Hz	•	•	•			•
100Hz	•	•	•			•
400Hz	•	•	•			•
1kHz	•	•	•			•
2.5kHz		•				•
5kHz	•		•			
12kHz	•	•	•			•

Stereo separation >18dB

2.17 FM-MODULATED AUDIO WHITE NOISE TEST INF-FREQUENCY RESPONSE

Test Setup refers RX57 section 5.6

For Stream 221, the waveform is stable 1 seconds after periodic silence.
Bandwidth 20~20KHZ

Frequency (Hz)	LL	UL	Units
21.5	-2.5	1.5	dBr1k
32.3	-2.5	1.5	dBr1k
118.4	-2.0	2.0	dBr1k
398.4	-2.0	2.0	dBr1k
1001.3	ref	ref	dB
6998.3	-1.5	2.5	dBr1k
12004.8	-1.5	2.5	dBr1k
13996.6	-2.0	2.0	dBr1k
14502.6	-3.0	1.0	dBr1k
14804.1	-8.0	-4.0	dBr1k

3.0 POWER REQUIREMENTS

3.1 AC-DC POWER SUPPLY

The UPA-US shall operate when a power supply dc voltage is applied to the output interface

- Input voltage: 90~264VAC 50/60HZ
- Output voltage: 1.5A 6.5VDC±5%
- Ripple Noise: Less 90mVP-P @1.5A
- ESD: ±18KV
- OVP: OVP 10VDC
- OCP: 2A
- Safety: UL60950
- EMC: FCC CLASSB

3.2 CIGARETTE LIGHTER ADAPTER

The UPA-US shall operate when a power supply dc voltage is applied to the output interface

- Input voltage: 9~24VDC
- Output voltage: 1.5A 6.5VDC±5%
- Ripple Noise: Less 100mVP-P @1.5A
- ESD: ±18KV
- OVP 10VDC
- Fuse Protect: 2A