

FCC Test Report

(Part 27 – LTE Band 4 / 7 / 12 / 17 / 66 / 71)

Report No.: RFBHKI-WTW-P22030766-2

FCC ID: NKRUMC-STD31LFN

Test Model: UMC-STD31LFN

Received Date: Mar. 18, 2022

Test Date: Apr. 06 ~ Apr. 15, 2022

Issued Date: Jul. 04, 2022

Applicant: Wistron NeWeb Corporation

Address: 20 Park Ave. II, Hsinchu Science Park, Hsinchu 308, Taiwan

Issued By: Bureau Veritas Consumer Products Services (H.K.) Ltd., Taoyuan Branch
Lin Kou Laboratories

Lab Address: No. 47-2, 14th Ling, Chia Pau Vil., Lin Kou Dist., New Taipei City, Taiwan

Test Location(1): No. 19, Hwa Ya 2nd Rd., Wen Hwa Vil., Kwei Shan Dist., Taoyuan City
33383, Taiwan

**FCC Registration /
Designation Number(1):** 788550 / TW0003

Test Location(2): No. 70, Wenming Rd., Guishan Dist., Taoyuan City 333, Taiwan (R.O.C.)

**FCC Registration /
Designation Number(2):** 281270 / TW0032



This report is governed by, and incorporates by reference, the Conditions of Testing as posted at the date of issuance of this report at <http://www.bureauveritas.com/home/about-us/our-business/cps/about-us/terms-conditions/> and is intended for your exclusive use. Any copying or replication of this report to or for any other person or entity, or use of our name or trademark, is permitted only with our prior written permission. This report sets forth our findings solely with respect to the test samples identified herein. The results set forth in this report are not indicative or representative of the quality or characteristics of the lot from which a test sample was taken or any similar or identical product unless specifically and expressly noted. Our report includes all of the tests requested by you and the results thereof based upon the information that you provided to us. Measurement uncertainty is only provided upon request for accredited tests. Statements of conformity are based on simple acceptance criteria without taking measurement uncertainty into account, unless otherwise requested in writing. You have 60 days from date of issuance of this report to notify us of any material error or omission caused by our negligence or if you require measurement uncertainty; provided, however, that such notice shall be in writing and shall specifically address the issue you wish to raise. A failure to raise such issue within the prescribed time shall constitute your unqualified acceptance of the completeness of this report, the tests conducted and the correctness of the report contents.

Table of Contents

| | |
|--|-----------|
| Release Control Record | 4 |
| 1 Certificate of Conformity | 5 |
| 2 Summary of Test Results | 6 |
| 2.1 Measurement Uncertainty..... | 6 |
| 2.2 Test Site and Instruments..... | 7 |
| 3 General Information | 8 |
| 3.1 General Description of EUT..... | 8 |
| 3.2 Configuration of System under Test..... | 11 |
| 3.2.1 Description of Support Units..... | 11 |
| 3.3 Test Mode Applicability and Tested Channel Detail..... | 12 |
| 3.4 EUT Operating Conditions..... | 25 |
| 3.5 General Description of Applied Standards and References..... | 25 |
| 4 Test Types and Results | 26 |
| 4.1 Output Power Measurement..... | 26 |
| 4.1.1 Limits of Output Power Measurement..... | 26 |
| 4.1.2 Test Procedures..... | 26 |
| 4.1.3 Test Setup..... | 26 |
| 4.1.4 Test Results..... | 27 |
| 4.2 Modulation Characteristics Measurement..... | 79 |
| 4.2.1 Limits of Modulation Characteristics..... | 79 |
| 4.2.2 Test Procedure..... | 79 |
| 4.2.3 Test Setup..... | 79 |
| 4.2.4 Test Results..... | 80 |
| 4.3 Frequency Stability Measurement..... | 86 |
| 4.3.1 Limits of Frequency Stability Measurement..... | 86 |
| 4.3.2 Test Procedure..... | 86 |
| 4.3.3 Test Instruments..... | 86 |
| 4.3.4 Test Setup..... | 86 |
| 4.3.5 Test Results..... | 87 |
| 4.4 Occupied Bandwidth Measurement..... | 113 |
| 4.4.1 Limits of Occupied Bandwidth Measurement..... | 113 |
| 4.4.2 Test Procedure..... | 113 |
| 4.4.3 Test Setup..... | 113 |
| 4.4.4 Test Result..... | 114 |
| 4.5 Channel Edge / Out-of-Band Emissions Measurement..... | 140 |
| 4.5.1 Limits of Band Edge / Out-of-Band Emissions Measurement..... | 140 |
| 4.5.2 Test Setup..... | 140 |
| 4.5.3 Test Procedures..... | 141 |
| 4.5.4 Test Results..... | 142 |
| 4.6 Peak to Average Ratio..... | 168 |
| 4.6.1 Limits of Peak to Average Ratio Measurement..... | 168 |
| 4.6.2 Test Setup..... | 168 |
| 4.6.3 Test Procedures..... | 168 |
| 4.6.4 Test Results..... | 169 |
| 4.7 Conducted Spurious Emissions..... | 195 |
| 4.7.1 Limits of Conducted Spurious Emissions Measurement..... | 195 |
| 4.7.2 Test Setup..... | 195 |
| 4.7.3 Test Procedure..... | 196 |
| 4.7.4 Test Results..... | 197 |
| 4.8 Radiated Emission Measurement..... | 223 |
| 4.8.1 Limits of Radiated Emission Measurement..... | 223 |
| 4.8.2 Test Procedure..... | 224 |
| 4.8.3 Deviation from Test Standard..... | 224 |

| | |
|---|------------|
| 4.8.4 Test Setup..... | 225 |
| 4.8.5 Test Results | 226 |
| 5 Pictures of Test Arrangements..... | 268 |
| Appendix – Information of the Testing Laboratories | 269 |

Release Control Record

| Issue No. | Description | Date Issued |
|------------------------|------------------|---------------|
| RFBHKI-WTW-P22030766-2 | Original release | Jul. 04, 2022 |

1 Certificate of Conformity

Product: Cellular module
Brand: WNC
Test Model: UMC-STD31LFN
Sample Status: Engineering sample
Applicant: Wistron NeWeb Corporation
Test Date: Apr. 06 ~ Apr. 18, 2022
Standards: FCC Part 27, Subpart C, H, L, M, N

The above equipment has been tested by **Bureau Veritas Consumer Products Services (H.K.) Ltd., Taoyuan Branch**, and found compliance with the requirement of the above standards. The test record, data evaluation & Equipment Under Test (EUT) configurations represented herein are true and accurate accounts of the measurements of the sample's RF characteristics under the conditions specified in this report.

Prepared by : Pettie Chen , **Date:** Jul. 04, 2022
Pettie Chen / Senior Specialist

Approved by : Jeremy Lin , **Date:** Jul. 04, 2022
Jeremy Lin / Project Engineer

2 Summary of Test Results

| Applied Standard: FCC Part 27 & Part 2 | | | | | | | |
|--|------------------------|------------------------------|------------------------|---------------------------|---|--------|---|
| FCC Clause | | | | | Test Item | Result | Remarks |
| WCDMA B4 / LTE B4 | LTE B12 / LTE B71 | LTE B7 | LTE B17 | LTE B66 | | | |
| 2.1046 27.50 (d)(4) | 2.1046 27.50 (c) | 2.1046 27.50 (h)(2) | 2.1046 27.50(c) | 2.1046 27.50 (d)(4) | Equivalent Isotropically Radiated Power / Equivalent Radiated Power | Pass | Meet the requirement of limit. |
| 2.1047 | 2.1047 | 2.1047 | 2.1047 | 2.1047 | Modulation Characteristics | Pass | Meet the requirement of limit. |
| 27.50 (d)(5) | ---- | ---- | ---- | 27.50 (d)(5) | Peak To Average Ratio | Pass | Meet the requirement of limit. |
| 2.1055 27.54 | 2.1055 27.54 | 2.1055 27.54 | 2.1055 27.54 | 2.1055 27.54 | Frequency Stability Stay with the authorized bands of operation | Pass | Meet the requirement of limit. |
| 2.1049 | 2.1049 | 2.1049 | 2.1049 | 2.1049 | Occupied Bandwidth | Pass | Meet the requirement of limit. |
| 2.1051 27.53 (h) | 2.1051 27.53 (g) | 2.1051 27.53 (m)(4)(6) | 2.1051 27.53 (g) | 2.1051 27.53 (h) | Band Edge / Out of Band Emissions Measurements | Pass | Meet the requirement of limit. |
| 2.1051 27.53 (h) | 2.1051 27.53 (g) | 2.1051 27.53 (m)(4)(6) | 2.1051 27.53 (g) | 2.1051 27.53 (h) | Conducted Spurious Emissions | Pass | Meet the requirement of limit. |
| 2.1053 27.53 (h) | 2.1053 27.53 (g) | 2.1053 27.53 (m)(4)(6) | 2.1053 27.53 (g) | 2.1053 27.53 (h) | Radiated Spurious Emissions | Pass | Meet the requirement of limit. Minimum passing margin is -10.18dB at 62.01MHz. |

Note: Determining compliance based on the results of the compliance measurement, not taking into account measurement instrumentation uncertainty.

2.1 Measurement Uncertainty

Where relevant, the following measurement uncertainty levels have been estimated for tests performed on the EUT as specified in CISPR 16-4-2:

| Measurement | Frequency | Expanded Uncertainty (k=2) (\pm) |
|--------------------------------|------------------|--------------------------------------|
| Radiated Emissions up to 1 GHz | 9kHz ~ 30MHz | 3.04 dB |
| | 30MHz ~ 200MHz | 3.59 dB |
| | 200MHz ~ 1000MHz | 3.60 dB |
| Radiated Emissions above 1 GHz | 1GHz ~ 18GHz | 2.29 dB |
| | 18GHz ~ 40GHz | 2.29 dB |

2.2 Test Site and Instruments

| Description & Manufacturer | Model No. | Serial No. | Cal. Date | Cal. Due |
|---|---------------------------------|---------------------------|---------------|---------------|
| Test Receiver KEYSIGHT | N9038B | MY60180018 | Feb. 18, 2022 | Feb. 17, 2023 |
| Spectrum Analyzer KEYSIGHT | N9020B | MY60110513 | Dec. 24, 2021 | Dec. 23, 2022 |
| BILOG Antenna SCHWARZBECK | VULB9168 | 9168-1214 | Oct. 27, 2021 | Oct. 26, 2022 |
| HORN Antenna RF SPIN | DRH18-E | 210101A18E | Nov. 14, 2021 | Nov. 13, 2022 |
| HORN Antenna SCHWARZBECK | BBHA 9170 | 9170-1049 | Nov. 14, 2021 | Nov. 13, 2022 |
| Loop Antenna TESEQ | HLA 6121 | 45745 | Jul. 21, 2021 | Jul. 20, 2022 |
| Preamplifier EMCI | EMC330N | 980798 | Jan. 17, 2022 | Jan. 16, 2023 |
| Preamplifier EMCI | EMC118A45SE | 980809 | Dec. 30, 2021 | Dec. 29, 2022 |
| Preamplifier EMCI | EMC184045SE | 980786 | Jan. 17, 2022 | Jan. 16, 2023 |
| RF signal cable EMCI | EMC104-SM-SM-(9000+3000+1000) | 201244+ 201232+ 210103 | Jan. 17, 2022 | Jan. 16, 2023 |
| RF signal cable EMCI | EMCCFD400-NM-NM-(9000+3000+500) | 201251+ 201249+ 201248 | Jan. 17, 2022 | Jan. 16, 2023 |
| RF signal cable EMCI | EMC101G-KM-KM-(5000+3000+2000) | 201261+201258+ 201255 | Jan. 17, 2022 | Jan. 16, 2023 |
| Software BV ADT | ADT_Radiated_V7.6.15.9.5 | NA | NA | NA |
| Antenna Tower Max-Full | MFA-515BSN | NA | NA | NA |
| Turn Table Max-Full | MFT-201SS | NA | NA | NA |
| Turn Table Controller Max-Full | MF-7802BS | MF780208676 | NA | NA |
| Radio Communication Analyzer Anritsu | MT8821C | 6261806803 | Feb. 16, 2022 | Feb. 15, 2023 |
| Spectrum Analyzer KEYSIGHT | N9030B | MY57140953 | Jul. 06, 2021 | Jul. 05, 2022 |
| Temperature & Humidity Chamber TERCHY | HRM-120RF | 931022 | Jan. 03, 2022 | Jan. 02, 2023 |
| DC power supply KEYSIGHT | U8002A | MY56330015 | NA | NA |
| Digital Multimeter Fluke | 87-III | 70360755 | Jul. 08, 2021 | Jul. 07, 2022 |

Note: 1. The calibration interval of the above test instruments is 12 months and the calibrations are traceable to NML/ROC and NIST/USA.
2. The test was performed in WM Chamber 9.

3 General Information

3.1 General Description of EUT

| | | |
|---------------------------------------|--|-----------------------|
| Product | Cellular module | |
| Brand | WNC | |
| Test Model | UMC-STD31LFN | |
| Sample Status | Engineering sample | |
| Power Supply Rating | 4.0Vdc | |
| Modulation Type | QPSK, 16QAM, 64QAM | |
| Operating Frequency | LTE Band 4 (Channel Bandwidth 1.4MHz) | 1710.7MHz ~ 1754.3MHz |
| | LTE Band 4 (Channel Bandwidth 3MHz) | 1711.5MHz ~ 1753.5MHz |
| | LTE Band 4 (Channel Bandwidth 5MHz) | 1712.5MHz ~ 1752.5MHz |
| | LTE Band 4 (Channel Bandwidth 10MHz) | 1715.0MHz ~ 1750.0MHz |
| | LTE Band 4 (Channel Bandwidth 15MHz) | 1717.5MHz ~ 1747.5MHz |
| | LTE Band 4 (Channel Bandwidth 20MHz) | 1720.0MHz ~ 1745.0MHz |
| | LTE Band 7 (Channel Bandwidth 5MHz) | 2502.5MHz ~ 2567.5MHz |
| | LTE Band 7 (Channel Bandwidth 10MHz) | 2505.0MHz ~ 2565.0MHz |
| | LTE Band 7 (Channel Bandwidth 15MHz) | 2507.5MHz ~ 2562.5MHz |
| | LTE Band 7 (Channel Bandwidth 20MHz) | 2510.0MHz ~ 2560.0MHz |
| | LTE Band 12 (Channel Bandwidth 1.4MHz) | 699.7MHz ~ 715.3MHz |
| | LTE Band 12 (Channel Bandwidth 3MHz) | 700.5MHz ~ 714.5MHz |
| | LTE Band 12 (Channel Bandwidth 5MHz) | 701.5MHz ~ 713.5MHz |
| | LTE Band 12 (Channel Bandwidth 10MHz) | 704.0MHz ~ 711.0MHz |
| | LTE Band 17 (Channel Bandwidth: 5MHz) | 706.5MHz ~ 713.5 MHz |
| | LTE Band 17 (Channel Bandwidth: 10MHz) | 709.0MHz ~ 711.0 MHz |
| | LTE Band 66 (Channel Bandwidth 1.4MHz) | 1710.7MHz ~ 1779.3MHz |
| | LTE Band 66 (Channel Bandwidth 3MHz) | 1711.5MHz ~ 1778.5MHz |
| | LTE Band 66 (Channel Bandwidth 5MHz) | 1712.5MHz ~ 1777.5MHz |
| | LTE Band 66 (Channel Bandwidth 10MHz) | 1715.0MHz ~ 1775.0MHz |
| | LTE Band 66 (Channel Bandwidth 15MHz) | 1717.5MHz ~ 1772.5MHz |
| | LTE Band 66 (Channel Bandwidth 20MHz) | 1720.0MHz ~ 1770.0MHz |
| | LTE Band 71 (Channel Bandwidth 5MHz) | 665.5MHz ~ 695.5MHz |
| LTE Band 71 (Channel Bandwidth 10MHz) | 668.0MHz ~ 693.0MHz | |
| LTE Band 71 (Channel Bandwidth 15MHz) | 670.5MHz ~ 690.5MHz | |
| LTE Band 71 (Channel Bandwidth 20MHz) | 673.0MHz ~ 688.0MHz | |

| | | QPSK | 16QAM | 64QAM | |
|----------------|--|--|---------------------------------------|-------------------------|-------------------------|
| | | Max. EIRP Power | LTE Band 4 (Channel Bandwidth 1.4MHz) | 289.068mW (24.61dBm) | 233.884mW (23.69dBm) |
| | LTE Band 4 (Channel Bandwidth 3MHz) | 281.838mW (24.50dBm) | 227.510mW (23.57dBm) | 178.649mW (22.52dBm) | |
| | LTE Band 4 (Channel Bandwidth 5MHz) | 290.402mW (24.63dBm) | 232.809mW (23.67dBm) | 184.077mW (22.65dBm) | |
| | LTE Band 4 (Channel Bandwidth 10MHz) | 282.488mW (24.51dBm) | 229.615mW (23.61dBm) | 181.552mW (22.59dBm) | |
| | LTE Band 4 (Channel Bandwidth 15MHz) | 283.792mW (24.53dBm) | 227.510mW (23.57dBm) | 178.649mW (22.52dBm) | |
| | LTE Band 4 (Channel Bandwidth 20MHz) | 281.190mW (24.49dBm) | 226.986mW (23.56dBm) | 180.302mW (22.56dBm) | |
| | LTE Band 7 (Channel Bandwidth 5MHz) | 300.608mW (24.78dBm) | 242.103mW (23.84dBm) | 191.867mW (22.83dBm) | |
| | LTE Band 7 (Channel Bandwidth 10MHz) | 303.389mW (24.82dBm) | 243.781mW (23.87dBm) | 190.985mW (22.81dBm) | |
| | LTE Band 7 (Channel Bandwidth 15MHz) | 304.789mW (24.84dBm) | 246.037mW (23.91dBm) | 194.089mW (22.88dBm) | |
| | LTE Band 7 (Channel Bandwidth 20MHz) | 304.089mW (24.83dBm) | 244.906mW (23.89dBm) | 191.867mW (22.83dBm) | |
| | LTE Band 66 (Channel Bandwidth 1.4MHz) | 278.612mW (24.45dBm) | 226.464mW (23.55dBm) | 178.649mW (22.52dBm) | |
| | LTE Band 66 (Channel Bandwidth 3MHz) | 278.612mW (24.45dBm) | 222.331mW (23.47dBm) | 175.388mW (22.44dBm) | |
| | LTE Band 66 (Channel Bandwidth 5MHz) | 281.838mW (24.50dBm) | 225.944mW (23.54dBm) | 178.649mW (22.52dBm) | |
| | LTE Band 66 (Channel Bandwidth 10MHz) | 279.254mW (24.46dBm) | 223.872mW (23.50dBm) | 174.582mW (22.42dBm) | |
| | LTE Band 66 (Channel Bandwidth 15MHz) | 279.254mW (24.46dBm) | 226.986mW (23.56dBm) | 176.604mW (22.47dBm) | |
| | LTE Band 66 (Channel Bandwidth 20MHz) | 277.332mW (24.43dBm) | 224.905mW (23.52dBm) | 178.649mW (22.52dBm) | |
| Max. ERP Power | | QPSK | 16QAM | 64QAM | |
| | | LTE Band 12 (Channel Bandwidth 1.4MHz) | 185.353mW (22.68dBm) | 149.279mW (21.74dBm) | 117.761mW (20.71dBm) |
| | | LTE Band 12 (Channel Bandwidth 3MHz) | 183.654mW (22.64dBm) | 149.279mW (21.74dBm) | 116.145mW (20.65dBm) |
| | | LTE Band 12 (Channel Bandwidth 5MHz) | 180.302mW (22.56dBm) | 145.211mW (21.62dBm) | 113.763mW (20.56dBm) |
| | | LTE Band 12 (Channel Bandwidth 10MHz) | 184.077mW (22.65dBm) | 149.279mW (21.74dBm) | 115.878mW (20.64dBm) |
| | | LTE Band 17 (Channel Bandwidth: 5MHz) | 189.671mW (22.78dBm) | 154.170mW (21.88dBm) | 122.180mW (20.87dBm) |
| | | LTE Band 17 (Channel Bandwidth: 10MHz) | 188.799mW (22.76dBm) | 152.405mW (21.83dBm) | 119.674mW (20.78dBm) |
| | | LTE Band 71 (Channel Bandwidth 5MHz) | 202.768mW (23.07dBm) | 162.930mW (22.12dBm) | 128.529mW (21.09dBm) |
| | | LTE Band 71 (Channel Bandwidth 10MHz) | 207.014mW (23.16dBm) | 164.816mW (22.17dBm) | 130.918mW (21.17dBm) |
| | | LTE Band 71 (Channel Bandwidth 15MHz) | 208.449mW (23.19dBm) | 169.044mW (22.28dBm) | 131.220mW (21.18dBm) |
| | | LTE Band 71 (Channel Bandwidth 20MHz) | 201.372mW (23.04dBm) | 162.181mW (22.10dBm) | 126.183mW (21.01dBm) |

| | | | | |
|---------------------------------------|--|---------|---------|---------|
| Emission Designator | | QPSK | 16QAM | 64QAM |
| | LTE Band 4 (Channel Bandwidth 1.4MHz) | 1M09G7D | 1M09D7W | 1M09D7W |
| | LTE Band 4 (Channel Bandwidth 3MHz) | 2M69G7D | 2M69D7W | 2M69D7W |
| | LTE Band 4 (Channel Bandwidth 5MHz) | 4M50G7D | 4M49D7W | 4M50D7W |
| | LTE Band 4 (Channel Bandwidth 10MHz) | 8M98G7D | 8M98D7W | 8M98D7W |
| | LTE Band 4 (Channel Bandwidth 15MHz) | 13M5G7D | 13M5D7W | 13M5D7W |
| | LTE Band 4 (Channel Bandwidth 20MHz) | 18M0G7D | 18M0D7W | 18M0D7W |
| | LTE Band 7 (Channel Bandwidth 5MHz) | 4M50G7D | 4M49D7W | 4M50D7W |
| | LTE Band 7 (Channel Bandwidth 10MHz) | 8M98G7D | 8M99D7W | 8M99D7W |
| | LTE Band 7 (Channel Bandwidth 15MHz) | 13M5G7D | 13M5D7W | 13M5D7W |
| | LTE Band 7 (Channel Bandwidth 20MHz) | 18M0G7D | 18M0D7W | 18M0D7W |
| | LTE Band 12 (Channel Bandwidth 1.4MHz) | 1M09G7D | 1M09D7W | 1M09D7W |
| | LTE Band 12 (Channel Bandwidth 3MHz) | 2M69G7D | 2M69D7W | 2M69D7W |
| | LTE Band 12 (Channel Bandwidth 5MHz) | 4M50G7D | 4M50D7W | 4M50D7W |
| | LTE Band 12 (Channel Bandwidth 10MHz) | 9M01G7D | 9M01D7W | 9M01D7W |
| | LTE Band 17 (Channel Bandwidth: 5MHz) | 4M50G7D | 4M50D7W | 4M50D7W |
| | LTE Band 17 (Channel Bandwidth: 10MHz) | 9M00G7D | 9M00D7W | 9M01D7W |
| | LTE Band 66 (Channel Bandwidth 1.4MHz) | 1M09G7D | 1M09D7W | 1M09D7W |
| | LTE Band 66 (Channel Bandwidth 3MHz) | 2M69G7D | 2M69D7W | 2M69D7W |
| | LTE Band 66 (Channel Bandwidth 5MHz) | 4M50G7D | 4M49D7W | 4M50D7W |
| | LTE Band 66 (Channel Bandwidth 10MHz) | 8M98G7D | 8M98D7W | 8M98D7W |
| | LTE Band 66 (Channel Bandwidth 15MHz) | 13M5G7D | 13M5D7W | 13M5D7W |
| | LTE Band 66 (Channel Bandwidth 20MHz) | 18M0G7D | 18M0D7W | 18M0D7W |
| LTE Band 71 (Channel Bandwidth 5MHz) | 4M49G7D | 4M49D7W | 4M50D7W | |
| LTE Band 71 (Channel Bandwidth 10MHz) | 8M99G7D | 8M99D7W | 9M00D7W | |
| LTE Band 71 (Channel Bandwidth 15MHz) | 13M5G7D | 13M5D7W | 13M5D7W | |
| LTE Band 71 (Channel Bandwidth 20MHz) | 18M0G7D | 18M0D7W | 18M0D7W | |
| Antenna Type | Refer to Note as below | | | |
| Antenna Connector | Refer to Note as below | | | |
| Accessory Device | NA | | | |
| Cable Supplied | NA | | | |

Note: The antenna information is listed as below.

| Type | Connector | Gain (dBi) | | | | | | | | | | | | | |
|--------|-----------|------------|----------|----------|----------|--------|--------|--------|--------|---------|---------|---------|---------|---------|---------|
| | | GSM 850 | GSM 1900 | WCDMA B2 | WCDMA B5 | LTE B2 | LTE B4 | LTE B5 | LTE B7 | LTE B12 | LTE B17 | LTE B25 | LTE B26 | LTE B66 | LTE B71 |
| Dipole | SMA | 1.82 | 1.80 | 1.80 | 1.82 | 1.80 | 1.57 | 1.82 | 2.15 | 2.02 | 2.02 | 1.80 | 1.82 | 1.57 | 2.02 |

* The above Antenna information is declared by manufacturer and for more detailed features description, please refer to the manufacturer's specifications, the laboratory shall not be held responsible.

3.2 Configuration of System under Test

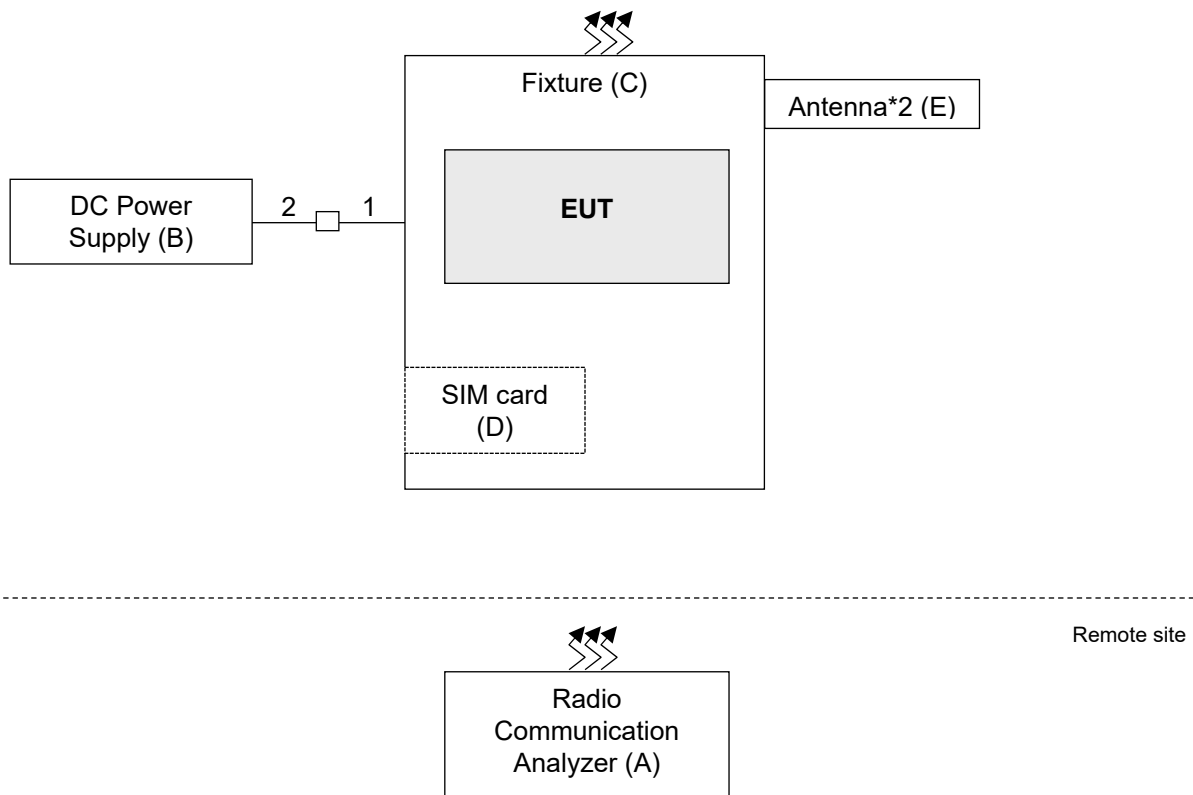

3.2.1 Description of Support Units

The EUT has been tested as an independent unit together with other necessary accessories or support units. The following support units or accessories were used to form a representative test configuration during the tests.

| ID | Product | Brand | Model No. | Serial No. | FCC ID | Remarks |
|----|------------------------------|----------|-----------|------------|--------|-----------------------|
| A. | Radio Communication Analyzer | Anritsu | MT8820C | 6201240432 | NA | For LTE |
| B. | DC Power Supply | TOP WARD | 6603A | 725906 | NA | - |
| C. | Fixture | NA | NA | NA | NA | Supplied by applicant |
| D. | SIM Card | R&S | CRT-Z3 | NA | NA | Provided by Lab |
| E. | Antenna*2 | NA | NA | NA | NA | Supplied by applicant |

Note:

- All power cords of the above support units are non-shielded (1.8m).
- Item A acted as a communication partner to transfer data.

| ID | Descriptions | Qty. | Length (m) | Shielding (Yes/No) | Cores (Qty.) | Remarks |
|----|----------------|------|------------|--------------------|--------------|---------|
| 1. | DC Power Cable | 1 | 0.1 | N | 0 | - |
| 2. | DC Power Cable | 1 | 1.0 | N | 0 | - |

3.3 Test Mode Applicability and Tested Channel Detail

Pre-Scan has been conducted to determine the worst-case mode from all possible combinations between available modulations, data rates, XYZ axis and antenna ports. The worst case was found when positioned as the table below. Following channel(s) was (were) selected for the final test as listed below:

| Band | Radiated Emission |
|-------------|-------------------|
| LTE Band 4 | Z-plane |
| LTE Band 7 | Z-plane |
| LTE Band 12 | Z-plane |
| LTE Band 17 | Z-plane |
| LTE Band 66 | Z-plane |
| LTE Band 71 | Z-plane |

LTE Band 4

| EUT Configure Mode | Test Item | Available Channel | Tested Channel | Channel Bandwidth | Modulation | Mode |
|--------------------|----------------------------|-------------------|---|-------------------|-------------------------|-------------------|
| - | EIRP | 19957 to 20393 | 19957 (1710.7MHz), 20175 (1732.5MHz), 20393 (1754.3MHz) | 1.4MHz | QPSK / 16QAM / 64QAM | 1 Half Full |
| | | 19965 to 20385 | 19965 (1711.5MHz), 20175 (1732.5MHz), 20385 (1753.5MHz) | 3MHz | QPSK / 16QAM / 64QAM | 1 Half Full |
| | | 19975 to 20375 | 19975 (1712.5MHz), 20175 (1732.5MHz), 20375 (1752.5MHz) | 5MHz | QPSK / 16QAM / 64QAM | 1 Half Full |
| | | 20000 to 20350 | 20000 (1715.0MHz), 20175 (1732.5MHz), 20350 (1750.0MHz) | 10MHz | QPSK / 16QAM / 64QAM | 1 Half Full |
| | | 20025 to 20325 | 20025 (1717.5MHz), 20175 (1732.5MHz), 20325 (1747.5MHz) | 15MHz | QPSK / 16QAM / 64QAM | 1 Half Full |
| | | 20050 to 20300 | 20050 (1720.0MHz), 20175 (1732.5MHz), 20300 (1745.0MHz) | 20MHz | QPSK / 16QAM / 64QAM | 1 Half Full |
| - | Modulation Characteristics | 20050 to 20300 | 20175 (1732.5MHz) | 20MHz | QPSK / 16QAM / 64QAM | Full |
| - | Frequency Stability | 19957 to 20393 | 19957 (1710.7MHz), 20393 (1754.3MHz) | 1.4MHz | QPSK | Full |
| | | 19965 to 20385 | 19965 (1711.5MHz), 20385 (1753.5MHz) | 3MHz | QPSK | Full |
| | | 19975 to 20375 | 19975 (1712.5MHz), 20375 (1752.5MHz) | 5MHz | QPSK | Full |
| | | 20000 to 20350 | 20000 (1715.0MHz), 20350 (1750.0MHz) | 10MHz | QPSK | Full |
| | | 20025 to 20325 | 20025 (1717.5MHz), 20325 (1747.5MHz) | 15MHz | QPSK | Full |
| | | 20050 to 20300 | 20050 (1720.0MHz), 20300 (1745.0MHz) | 20MHz | QPSK | Full |

| EUT Configure Mode | Test Item | Available Channel | Tested Channel | Channel Bandwidth | Modulation | Mode |
|--------------------|--------------------|-------------------|---|-------------------|-------------------------|-------------------|
| - | Emission Bandwidth | 19957 to 20393 | 19957 (1710.7MHz), 20175 (1732.5MHz), 20393 (1754.3MHz) | 1.4MHz | QPSK / 16QAM / 64QAM | Full |
| | | 19965 to 20385 | 19965 (1711.5MHz), 20175 (1732.5MHz), 20385 (1753.5MHz) | 3MHz | QPSK / 16QAM / 64QAM | Full |
| | | 19975 to 20375 | 19975 (1712.5MHz), 20175 (1732.5MHz), 20375 (1752.5MHz) | 5MHz | QPSK / 16QAM / 64QAM | Full |
| | | 20000 to 20350 | 20000 (1715.0MHz), 20175 (1732.5MHz), 20350 (1750.0MHz) | 10MHz | QPSK / 16QAM / 64QAM | Full |
| | | 20025 to 20325 | 20025 (1717.5MHz), 20175 (1732.5MHz), 20325 (1747.5MHz) | 15MHz | QPSK / 16QAM / 64QAM | Full |
| | | 20050 to 20300 | 20050 (1720.0MHz), 20175 (1732.5MHz), 20300 (1745.0MHz) | 20MHz | QPSK / 16QAM / 64QAM | Full |
| - | Band Edge | 19957 to 20393 | 19957 (1710.7MHz), 20393 (1754.3MHz) | 1.4MHz | QPSK | 1 Half Full |
| | | 19965 to 20385 | 19965 (1711.5MHz), 20385 (1753.5MHz) | 3MHz | QPSK | 1 Half Full |
| | | 19975 to 20375 | 19975 (1712.5MHz), 20375 (1752.5MHz) | 5MHz | QPSK | 1 Half Full |
| | | 20000 to 20350 | 20000 (1715.0MHz), 20350 (1750.0MHz) | 10MHz | QPSK | 1 Half Full |
| | | 20025 to 20325 | 20025 (1717.5MHz), 20325 (1747.5MHz) | 15MHz | QPSK | 1 Half Full |
| | | 20050 to 20300 | 20050 (1720.0MHz), 20300 (1745.0MHz) | 20MHz | QPSK | 1 Half Full |

| EUT Configure Mode | Test Item | Available Channel | Tested Channel | Channel Bandwidth | Modulation | Mode |
|--------------------|------------------------------|-------------------|---|-------------------|-------------------------|------|
| - | Peak To Average Ratio | 19957 to 20393 | 19957 (1710.7MHz), 20175 (1732.5MHz), 20393 (1754.3MHz) | 1.4MHz | QPSK / 16QAM / 64QAM | 1 |
| | | 19965 to 20385 | 19965 (1711.5MHz), 20175 (1732.5MHz), 20385 (1753.5MHz) | 3MHz | QPSK / 16QAM / 64QAM | 1 |
| | | 19975 to 20375 | 19975 (1712.5MHz), 20175 (1732.5MHz), 20375 (1752.5MHz) | 5MHz | QPSK / 16QAM / 64QAM | 1 |
| | | 20000 to 20350 | 20000 (1715.0MHz), 20175 (1732.5MHz), 20350 (1750.0MHz) | 10MHz | QPSK / 16QAM / 64QAM | 1 |
| | | 20025 to 20325 | 20025 (1717.5MHz), 20175 (1732.5MHz), 20325 (1747.5MHz) | 15MHz | QPSK / 16QAM / 64QAM | 1 |
| | | 20050 to 20300 | 20050 (1720.0MHz), 20175 (1732.5MHz), 20300 (1745.0MHz) | 20MHz | QPSK / 16QAM / 64QAM | 1 |
| - | Conducted Emission | 19957 to 20393 | 19957 (1710.7MHz), 20175 (1732.5MHz), 20393 (1754.3MHz) | 1.4MHz | QPSK | 1 |
| | | 19965 to 20385 | 19965 (1711.5MHz), 20175 (1732.5MHz), 20385 (1753.5MHz) | 3MHz | QPSK | 1 |
| | | 19975 to 20375 | 19975 (1712.5MHz), 20175 (1732.5MHz), 20375 (1752.5MHz) | 5MHz | QPSK | 1 |
| | | 20000 to 20350 | 20000 (1715.0MHz), 20175 (1732.5MHz), 20350 (1750.0MHz) | 10MHz | QPSK | 1 |
| | | 20025 to 20325 | 20025 (1717.5MHz), 20175 (1732.5MHz), 20325 (1747.5MHz) | 15MHz | QPSK | 1 |
| | | 20050 to 20300 | 20050 (1720.0MHz), 20175 (1732.5MHz), 20300 (1745.0MHz) | 20MHz | QPSK | 1 |
| - | Radiated Emission Below 1GHz | 20050 to 20300 | 20175 (1732.5MHz) | 20MHz | QPSK | 1 |
| - | Radiated Emission Above 1GHz | 19957 to 20393 | 19957 (1710.7MHz), 20175 (1732.5MHz), 20393 (1754.3MHz) | 1.4MHz | QPSK | 1 |
| | | 19975 to 20375 | 19975 (1712.5MHz), 20175 (1732.5MHz), 20375 (1752.5MHz) | 5MHz | QPSK | 1 |
| | | 20050 to 20300 | 20050 (1720.0MHz), 20175 (1732.5MHz), 20300 (1745.0MHz) | 20MHz | QPSK | 1 |

Note:

1. For radiated emission below 1GHz, select the worst radiated emission channel (above 1GHz) for final testing.
2. For radiated emission above 1GHz, according to 3GPP 36.521-1 Section 6.6.3.1.4.1, choose the lowest, 5MHz & highest channel bandwidth for final test.

3. The output power for QPSK, 16QAM and 64QAM, measured value of QPSK is higher than 16QAM, and 64QAM mode. Therefore, only Modulation characteristics, occupied bandwidth and Peak to average ratio items had been tested under QPSK, 16QAM and 64QAM modes, the other test items were performed under worse mode according to the maximum output power.

LTE Band 7

| EUT Configure Mode | Test item | Available channel | Tested channel | Channel Bandwidth | Modulation | Mode |
|--------------------|----------------------------|-------------------|---|-------------------|-------------------------|-------------------|
| - | EIRP | 20775 to 21425 | 20775 (2502.5MHz), 21100 (2535.0MHz), 21425 (2567.5MHz) | 5MHz | QPSK / 16QAM / 64QAM | 1 Half Full |
| | | 20800 to 21400 | 20800 (2505.0MHz), 21100 (2535.0MHz), 21400 (2565.0MHz) | 10MHz | QPSK / 16QAM / 64QAM | 1 Half Full |
| | | 20825 to 21375 | 20825 (2507.5MHz), 21100 (2535.0MHz), 21375 (2562.5MHz) | 15MHz | QPSK / 16QAM / 64QAM | 1 Half Full |
| | | 20850 to 21350 | 20850 (2510.0MHz), 21100 (2535.0MHz), 21350 (2560.0MHz) | 20MHz | QPSK / 16QAM / 64QAM | 1 Half Full |
| - | Modulation Characteristics | 20850 to 21350 | 21100 (2535.0MHz) | 20MHz | QPSK / 16QAM / 64QAM | Full |
| - | Frequency Stability | 20775 to 21425 | 20775 (2502.5MHz), 21425 (2567.5MHz) | 5MHz | QPSK | Full |
| | | 20800 to 21400 | 20800 (2505.0MHz), 21400 (2565.0MHz) | 10MHz | QPSK | Full |
| | | 20825 to 21375 | 20825 (2507.5MHz), 21375 (2562.5MHz) | 15MHz | QPSK | Full |
| | | 20850 to 21350 | 20850 (2510.0MHz), 21350 (2560.0MHz) | 20MHz | QPSK | Full |
| - | Emission Bandwidth | 20775 to 21425 | 20775 (2502.5MHz), 21100 (2535.0MHz), 21425 (2567.5MHz) | 5MHz | QPSK / 16QAM / 64QAM | Full |
| | | 20800 to 21400 | 20800 (2505.0MHz), 21100 (2535.0MHz), 21400 (2565.0MHz) | 10MHz | QPSK / 16QAM / 64QAM | Full |
| | | 20825 to 21375 | 20825 (2507.5MHz), 21100 (2535.0MHz), 21375 (2562.5MHz) | 15MHz | QPSK / 16QAM / 64QAM | Full |
| | | 20850 to 21350 | 20850 (2510.0MHz), 21100 (2535.0MHz), 21350 (2560.0MHz) | 20MHz | QPSK / 16QAM / 64QAM | Full |
| - | Out-of-Band Emissions | 20775 to 21425 | 20775 (2502.5MHz), 21425 (2567.5MHz) | 5MHz | QPSK | 1 Half Full |
| | | 20800 to 21400 | 20800 (2505.0MHz), 21400 (2565.0MHz) | 10MHz | QPSK | 1 Half Full |
| | | 20825 to 21375 | 20825 (2507.5MHz), 21375 (2562.5MHz) | 15MHz | QPSK | 1 Half Full |
| | | 20850 to 21350 | 20850 (2510.0MHz), 21350 (2560.0MHz) | 20MHz | QPSK | 1 Half Full |

| EUT Configure Mode | Test item | Available channel | Tested channel | Channel Bandwidth | Modulation | Mode |
|--------------------|------------------------------|-------------------|---|-------------------|-------------------------|------|
| - | Peak to Average Ratio | 20775 to 21425 | 20775 (2502.5MHz), 21100 (2535.0MHz), 21425 (2567.5MHz) | 5MHz | QPSK / 16QAM / 64QAM | 1 |
| | | 20800 to 21400 | 20800 (2505.0MHz), 21100 (2535.0MHz), 21400 (2565.0MHz) | 10MHz | QPSK / 16QAM / 64QAM | 1 |
| | | 20825 to 21375 | 20825 (2507.5MHz), 21100 (2535.0MHz), 21375 (2562.5MHz) | 15MHz | QPSK / 16QAM / 64QAM | 1 |
| | | 20850 to 21350 | 20850 (2510.0MHz), 21100 (2535.0MHz), 21350 (2560.0MHz) | 20MHz | QPSK / 16QAM / 64QAM | 1 |
| - | Conducted Emission | 20775 to 21425 | 20775 (2502.5MHz), 21100 (2535.0MHz), 21425 (2567.5MHz) | 5MHz | QPSK | 1 |
| | | 20800 to 21400 | 20800 (2505.0MHz), 21100 (2535.0MHz), 21400 (2565.0MHz) | 10MHz | QPSK | 1 |
| | | 20825 to 21375 | 20825 (2507.5MHz), 21100 (2535.0MHz), 21375 (2562.5MHz) | 15MHz | QPSK | 1 |
| | | 20850 to 21350 | 20850 (2510.0MHz), 21100 (2535.0MHz), 21350 (2560.0MHz) | 20MHz | QPSK | 1 |
| - | Radiated Emission Below 1GHz | 20850 to 21350 | 21350 (2560.0MHz) | 20MHz | QPSK | 1 |
| - | Radiated Emission Above 1GHz | 20775 to 21425 | 20775 (2502.5MHz), 21100 (2535.0MHz), 21425 (2567.5MHz) | 5MHz | QPSK | 1 |
| | | 20850 to 21350 | 20850 (2510.0MHz), 21100 (2535.0MHz), 21350 (2560.0MHz) | 20MHz | QPSK | 1 |

Note:

1. For radiated emission below 1GHz, select the worst radiated emission channel (above 1GHz) for final testing.
2. For radiated emission above 1GHz, according to 3GPP 36.521-1 Section 6.6.3.1.4.1, choose the 5MHz & highest channel bandwidth for final test.
3. The output power for QPSK, 16QAM and 64QAM, measured value of QPSK is higher than 16QAM, and 64QAM mode. Therefore, only Modulation characteristics, occupied bandwidth and Peak to average ratio items had been tested under QPSK, 16QAM and 64QAM modes, the other test items were performed under worse mode according to the maximum output power.

LTE Band 12

| EUT Configure Mode | Test item | Available channel | Tested channel | Channel Bandwidth | Modulation | Mode |
|--------------------|----------------------------|-------------------|---|-------------------|-------------------------|-------------------|
| - | ERP | 23017 to 23173 | 23017 (699.7MHz), 23095 (707.5MHz), 23173 (715.3MHz) | 1.4MHz | QPSK / 16QAM / 64QAM | 1 Half Full |
| | | 23025 to 23165 | 23025 (700.5MHz), 23095 (707.5MHz), 23165 (714.5MHz) | 3MHz | QPSK / 16QAM / 64QAM | 1 Half Full |
| | | 23035 to 23155 | 23035 (701.5MHz), 23095 (707.5MHz), 23155 (713.5MHz) | 5MHz | QPSK / 16QAM / 64QAM | 1 Half Full |
| | | 23060 to 23130 | 23060 (704.0MHz), 23095 (707.5MHz), 23130 (711.0 MHz) | 10MHz | QPSK / 16QAM / 64QAM | 1 Half Full |
| - | Modulation Characteristics | 23060 to 23130 | 23095 (707.5MHz) | 10MHz | QPSK / 16QAM / 64QAM | Full |
| - | Frequency Stability | 23017 to 23173 | 23017 (699.7MHz), 23173 (715.3MHz) | 1.4MHz | QPSK | Full |
| | | 23025 to 23165 | 23025 (700.5MHz), 23165 (714.5MHz) | 3MHz | QPSK | Full |
| | | 23035 to 23155 | 23035 (701.5MHz), 23155 (713.5MHz) | 5MHz | QPSK | Full |
| | | 23060 to 23130 | 23060 (704.0MHz), 23130 (711.0MHz) | 10MHz | QPSK | Full |
| - | Emission Bandwidth | 23017 to 23173 | 23017 (699.7MHz), 23095 (707.5MHz), 23173 (715.3MHz) | 1.4MHz | QPSK / 16QAM / 64QAM | Full |
| | | 23025 to 23165 | 23025 (700.5MHz), 23095 (707.5MHz), 23165 (714.5MHz) | 3MHz | QPSK / 16QAM / 64QAM | Full |
| | | 23035 to 23155 | 23035 (701.5MHz), 23095 (707.5MHz), 23155 (713.5MHz) | 5MHz | QPSK / 16QAM / 64QAM | Full |
| | | 23060 to 23130 | 23060 (704.0MHz), 23095 (707.5MHz), 23130 (711.0MHz) | 10MHz | QPSK / 16QAM / 64QAM | Full |
| - | Band Edge | 23017 to 23173 | 23017 (699.7MHz), 23173 (715.3MHz) | 1.4MHz | QPSK | 1 Half Full |
| | | 23025 to 23165 | 23025 (700.5MHz), 23165 (714.5MHz) | 3MHz | QPSK | 1 Half Full |
| | | 23035 to 23155 | 23035 (701.5MHz), 23155 (713.5MHz) | 5MHz | QPSK | 1 Half Full |
| | | 23060 to 23130 | 23060 (704.0MHz), 23130 (711.0MHz) | 10MHz | QPSK | 1 Half Full |

| EUT Configure Mode | Test item | Available channel | Tested channel | Channel Bandwidth | Modulation | Mode |
|--------------------|------------------------------|-------------------|--|-------------------|-------------------------|------|
| - | Peak to Average Ratio | 23017 to 23173 | 23017 (699.7MHz), 23095 (707.5MHz), 23173 (715.3MHz) | 1.4MHz | QPSK / 16QAM / 64QAM | 1 |
| | | 23025 to 23165 | 23025 (700.5MHz), 23095 (707.5MHz), 23165 (714.5MHz) | 3MHz | QPSK / 16QAM / 64QAM | 1 |
| | | 23035 to 23155 | 23035 (701.5MHz), 23095 (707.5MHz), 23155 (713.5MHz) | 5MHz | QPSK / 16QAM / 64QAM | 1 |
| | | 23060 to 23130 | 23060 (704.0MHz), 23095 (707.5MHz), 23130 (711.0MHz) | 10MHz | QPSK / 16QAM / 64QAM | 1 |
| - | Conducted Emission | 23017 to 23173 | 23017 (699.7MHz), 23095 (707.5MHz), 23173 (715.3MHz) | 1.4MHz | QPSK | 1 |
| | | 23025 to 23165 | 23025 (700.5MHz), 23095 (707.5MHz), 23165 (714.5MHz) | 3MHz | QPSK | 1 |
| | | 23035 to 23155 | 23035 (701.5MHz), 23095 (707.5MHz), 23155 (713.5MHz) | 5MHz | QPSK | 1 |
| | | 23060 to 23130 | 23060 (704.0MHz), 23095 (707.5MHz), 23130 (711.0MHz) | 10MHz | QPSK | 1 |
| - | Radiated Emission Below 1GHz | 23017 to 23173 | 23173 (715.3MHz) | 1.4MHz | QPSK | 1 |
| - | Radiated Emission Above 1GHz | 23017 to 23173 | 23017 (699.7MHz), 23095 (707.5MHz), 23173 (715.3MHz) | 1.4MHz | QPSK | 1 |
| | | 23035 to 23155 | 23035 (701.5MHz), 23095 (707.5MHz), 23155 (713.5MHz) | 5MHz | QPSK | 1 |
| | | 23060 to 23130 | 23060 (704.0MHz), 23095 (707.5MHz), 23130 (711.0MHz) | 10MHz | QPSK | 1 |

Note:

1. For radiated emission below 1GHz, select the worst radiated emission channel (above 1GHz) for final testing.
2. For radiated emission above 1GHz, according to 3GPP 36.521-1 Section 6.6.3.1.4.1, choose the lowest, 5MHz & highest channel bandwidth for final test.
3. The output power for QPSK, 16QAM and 64QAM, measured value of QPSK is higher than 16QAM, and 64QAM mode. Therefore, only Modulation characteristics, occupied bandwidth and Peak to average ratio items had been tested under QPSK, 16QAM and 64QAM modes, the other test items were performed under worse mode according to the maximum output power.

LTE Band 17

| EUT Configure Mode | Test item | Available channel | Tested channel | Channel Bandwidth | Modulation | RB # |
|--------------------|------------------------------|-------------------|--|-------------------|-------------------------|-------------------|
| - | ERP | 23755 to 23825 | 23755 (706.5MHz), 23790 (710.0MHz), 23825 (713.5MHz) | 5MHz | QPSK / 16QAM / 64QAM | 1 Half Full |
| | | 23780 to 23800 | 23780 (709.0MHz), 23790 (710.0MHz), 23800 (711.0MHz) | 10MHz | QPSK / 16QAM / 64QAM | 1 Half Full |
| - | Modulation Characteristics | 23780 to 23800 | 23790 (710.0MHz) | 10MHz | QPSK / 16QAM / 64QAM | Full |
| - | Frequency Stability | 23755 to 23825 | 23755 (706.5MHz), 23825 (713.5MHz) | 5MHz | QPSK | Full |
| | | 23780 to 23800 | 23780 (709.0MHz), 23800 (711.0MHz) | 10MHz | QPSK | Full |
| - | Emission Bandwidth | 23755 to 23825 | 23755 (706.5MHz), 23790 (710.0MHz), 23825 (713.5MHz) | 5MHz | QPSK / 16QAM / 64QAM | Full |
| | | 23780 to 23800 | 23780 (709.0MHz), 23790 (710.0MHz), 23800 (711.0MHz) | 10MHz | QPSK / 16QAM / 64QAM | Full |
| - | Band Edge | 23755 to 23825 | 23755 (706.5MHz), 23825 (713.5MHz) | 5MHz | QPSK | 1 Half Full |
| | | 23780 to 23800 | 23780 (709.0MHz), 23800 (711.0MHz) | 10MHz | QPSK | 1 Half Full |
| - | Peak to Average Ratio | 23755 to 23825 | 23755 (706.5MHz), 23790 (710.0MHz), 23825 (713.5MHz) | 5MHz | QPSK / 16QAM / 64QAM | 1 |
| | | 23780 to 23800 | 23780 (709.0MHz), 23790 (710.0MHz), 23800 (711.0MHz) | 10MHz | QPSK / 16QAM / 64QAM | 1 |
| - | Conducted Emission | 23755 to 23825 | 23755 (706.5MHz), 23790 (710.0MHz), 23825 (713.5MHz) | 5MHz | QPSK | 1 |
| | | 23780 to 23800 | 23780 (709.0MHz), 23790 (710.0MHz), 23800 (711.0MHz) | 10MHz | QPSK | 1 |
| - | Radiated Emission Below 1GHz | 23780 to 23800 | 23780 (709.0MHz) | 10MHz | QPSK | 1 |
| - | Radiated Emission Above 1GHz | 23755 to 23825 | 23755 (706.5MHz), 23790 (710.0MHz), 23825 (713.5MHz) | 5MHz | QPSK | 1 |
| | | 23780 to 23800 | 23780 (709.0MHz), 23790 (710.0MHz), 23800 (711.0MHz) | 10MHz | QPSK | 1 |

Note:

1. For radiated emission below 1GHz, select the worst radiated emission channel (above 1GHz) for final testing.
2. For radiated emission above 1GHz, according to 3GPP 36.521-1 Section 6.6.3.1.4.1, choose the 5MHz & highest channel bandwidth for final test.
3. The output power for QPSK, 16QAM and 64QAM, measured value of QPSK is higher than 16QAM, and 64QAM mode. Therefore, only Modulation characteristics, occupied bandwidth and Peak to average ratio

items had been tested under QPSK, 16QAM and 64QAM modes, the other test items were performed under worse mode according to the maximum output power.

LTE Band 66

| EUT Configure Mode | Test Item | Available Channel | Tested Channel | Channel Bandwidth | Modulation | Mode |
|--------------------|----------------------------|-------------------|--|-------------------|-------------------------|-------------------|
| - | EIRP | 131979 to 132665 | 131979 (1710.7MHz), 132322 (1745.0MHz), 132665 (1779.3MHz) | 1.4MHz | QPSK / 16QAM / 64QAM | 1 Half Full |
| | | 131987 to 132657 | 131987 (1711.5MHz), 132322 (1745.0MHz), 132657 (1778.5MHz) | 3MHz | QPSK / 16QAM / 64QAM | 1 Half Full |
| | | 131997 to 132647 | 131997 (1712.5MHz), 132322 (1745.0MHz), 132647 (1777.5MHz) | 5MHz | QPSK / 16QAM / 64QAM | 1 Half Full |
| | | 132022 to 132622 | 132022 (1715.0MHz), 132322 (1745.0MHz), 132622 (1775.0MHz) | 10MHz | QPSK / 16QAM / 64QAM | 1 Half Full |
| | | 132047 to 132597 | 132047 (1717.5MHz), 132322 (1745.0MHz), 132597 (1772.5MHz) | 15MHz | QPSK / 16QAM / 64QAM | 1 Half Full |
| | | 132072 to 132572 | 132072 (1720.0MHz), 132322 (1745.0MHz), 132572 (1770.0MHz) | 20MHz | QPSK / 16QAM / 64QAM | 1 Half Full |
| - | Modulation Characteristics | 132072 to 132572 | 132322 (1745.0MHz) | 20MHz | QPSK / 16QAM / 64QAM | Full |
| - | Frequency Stability | 131979 to 132665 | 131979 (1710.7MHz), 132665 (1779.3MHz) | 1.4MHz | QPSK | Full |
| | | 131987 to 132657 | 131987 (1711.5MHz), 132657 (1778.5MHz) | 3MHz | QPSK | Full |
| | | 131997 to 132647 | 131997 (1712.5MHz), 132647 (1777.5MHz) | 5MHz | QPSK | Full |
| | | 132022 to 132622 | 132022 (1715.0MHz), 132622 (1775.0MHz) | 10MHz | QPSK | Full |
| | | 132047 to 132597 | 132047 (1717.5MHz), 132597 (1772.5MHz) | 15MHz | QPSK | Full |
| | | 132072 to 132572 | 132072 (1720.0MHz), 132572 (1770.0MHz) | 20MHz | QPSK | Full |

| EUT Configure Mode | Test Item | Available Channel | Tested Channel | Channel Bandwidth | Modulation | Mode |
|--------------------|--------------------|-------------------|--|-------------------|-------------------------|-------------------|
| - | Emission Bandwidth | 131979 to 132665 | 131979 (1710.7MHz), 132322 (1745.0MHz), 132665 (1779.3MHz) | 1.4MHz | QPSK / 16QAM / 64QAM | Full |
| | | 131987 to 132657 | 131987 (1711.5MHz), 132322 (1745.0MHz), 132657 (1778.5MHz) | 3MHz | QPSK / 16QAM / 64QAM | Full |
| | | 131997 to 132647 | 131997 (1712.5MHz), 132322 (1745.0MHz), 132647 (1777.5MHz) | 5MHz | QPSK / 16QAM / 64QAM | Full |
| | | 132022 to 132622 | 132022 (1715.0MHz), 132322 (1745.0MHz), 132622 (1775.0MHz) | 10MHz | QPSK / 16QAM / 64QAM | Full |
| | | 132047 to 132597 | 132047 (1717.5MHz), 132322 (1745.0MHz), 132597 (1772.5MHz) | 15MHz | QPSK / 16QAM / 64QAM | Full |
| | | 132072 to 132572 | 132072 (1720.0MHz), 132322 (1745.0MHz), 132572 (1770.0MHz) | 20MHz | QPSK / 16QAM / 64QAM | Full |
| - | Band Edge | 131979 to 132665 | 131979 (1710.7MHz), 132665 (1779.3MHz) | 1.4MHz | QPSK | 1 Half Full |
| | | 131987 to 132657 | 131987 (1711.5MHz), 132657 (1778.5MHz) | 3MHz | QPSK | 1 Half Full |
| | | 131997 to 132647 | 131997 (1712.5MHz), 132647 (1777.5MHz) | 5MHz | QPSK | 1 Half Full |
| | | 132022 to 132622 | 132022 (1715.0MHz), 132622 (1775.0MHz) | 10MHz | QPSK | 1 Half Full |
| | | 132047 to 132597 | 132047 (1717.5MHz), 132597 (1772.5MHz) | 15MHz | QPSK | 1 Half Full |
| | | 132072 to 132572 | 132072 (1720.0MHz), 132572 (1770.0MHz) | 20MHz | QPSK | 1 Half Full |

| EUT Configure Mode | Test Item | Available Channel | Tested Channel | Channel Bandwidth | Modulation | Mode |
|--------------------|------------------------------|-------------------|--|-------------------|------------|------|
| - | Conducted Emission | 131979 to 132665 | 131979 (1710.7MHz), 132322 (1745.0MHz), 132665 (1779.3MHz) | 1.4MHz | QPSK | 1 |
| | | 131987 to 132657 | 131987 (1711.5MHz), 132322 (1745.0MHz), 132657 (1778.5MHz) | 3MHz | QPSK | 1 |
| | | 131997 to 132647 | 131997 (1712.5MHz), 132322 (1745.0MHz), 132647 (1777.5MHz) | 5MHz | QPSK | 1 |
| | | 132022 to 132622 | 132022 (1715.0MHz), 132322 (1745.0MHz), 132622 (1775.0MHz) | 10MHz | QPSK | 1 |
| | | 132047 to 132597 | 132047 (1717.5MHz), 132322 (1745.0MHz), 132597 (1772.5MHz) | 15MHz | QPSK | 1 |
| | | 132072 to 132572 | 132072 (1720.0MHz), 132322 (1745.0MHz), 132572 (1770.0MHz) | 20MHz | QPSK | 1 |
| - | Radiated Emission Below 1GHz | 132072 to 132572 | 132322 (1745.0MHz) | 20MHz | QPSK | 1 |
| - | Radiated Emission Above 1GHz | 131979 to 132665 | 131979 (1710.7MHz), 132322 (1745.0MHz), 132665 (1779.3MHz) | 1.4MHz | QPSK | 1 |
| | | 131997 to 132647 | 131997 (1712.5MHz), 132322 (1745.0MHz), 132647 (1777.5MHz) | 5MHz | QPSK | 1 |
| | | 132072 to 132572 | 132072 (1720.0MHz), 132322 (1745.0MHz), 132572 (1770.0MHz) | 20MHz | QPSK | 1 |

Note:

1. For radiated emission below 1GHz, select the worst radiated emission channel (above 1GHz) for final testing.
2. For radiated emission above 1GHz, according to 3GPP 36.521-1 Section 6.6.3.1.4.1, choose the lowest, 5MHz & highest channel bandwidth for final test.
3. The output power for QPSK, 16QAM and 64QAM, measured value of QPSK is higher than 16QAM, and 64QAM mode. Therefore, only Modulation characteristics, occupied bandwidth and Peak to average ratio items had been tested under QPSK, 16QAM and 64QAM modes, the other test items were performed under worse mode according to the maximum output power.

LTE Band 71

| EUT Configure Mode | Test item | Available channel | Tested channel | Channel Bandwidth | Modulation | Mode |
|--------------------|----------------------------|-------------------|---|-------------------|-------------------------|-------------------|
| - | ERP | 133147 to 133447 | 133147 (665.5MHz), 133297 (680.5MHz), 133447 (695.5MHz) | 5MHz | QPSK / 16QAM / 64QAM | 1 Half Full |
| | | 133172 to 133422 | 133172 (668.0MHz), 133297 (680.5MHz), 133422 (693.0MHz) | 10MHz | QPSK / 16QAM / 64QAM | 1 Half Full |
| | | 133197 to 133397 | 133197 (670.5MHz), 133297 (680.5MHz), 133397 (690.5MHz) | 15MHz | QPSK / 16QAM / 64QAM | 1 Half Full |
| | | 133222 to 133372 | 133222 (673.0MHz), 133297 (680.5MHz), 133372 (688.0MHz) | 20MHz | QPSK / 16QAM / 64QAM | 1 Half Full |
| - | Modulation Characteristics | 133222 to 133372 | 133297 (680.5MHz) | 20MHz | QPSK / 16QAM / 64QAM | Full |
| - | Frequency Stability | 133147 to 133447 | 133147 (665.5MHz), 133447 (695.5MHz) | 5MHz | QPSK | Full |
| | | 133172 to 133422 | 133172 (668.0MHz), 133422 (693.0MHz) | 10MHz | QPSK | Full |
| | | 133197 to 133397 | 133197 (670.5MHz), 133397 (690.5MHz) | 15MHz | QPSK | Full |
| | | 133222 to 133372 | 133222 (673.0MHz), 133372 (688.0MHz) | 20MHz | QPSK | Full |
| - | Emission Bandwidth | 133147 to 133447 | 133147 (665.5MHz), 133297 (680.5MHz), 133447 (695.5MHz) | 5MHz | QPSK / 16QAM / 64QAM | Full |
| | | 133172 to 133422 | 133172 (668.0MHz), 133297 (680.5MHz), 133422 (693.0MHz) | 10MHz | QPSK / 16QAM / 64QAM | Full |
| | | 133197 to 133397 | 133197 (670.5MHz), 133297 (680.5MHz), 133397 (690.5MHz) | 15MHz | QPSK / 16QAM / 64QAM | Full |
| | | 133222 to 133372 | 133222 (673.0MHz), 133297 (680.5MHz), 133372 (688.0MHz) | 20MHz | QPSK / 16QAM / 64QAM | Full |
| - | Band Edge | 133147 to 133447 | 133147 (665.5MHz), 133447 (695.5MHz) | 5MHz | QPSK | 1 Half Full |
| | | 133172 to 133422 | 133172 (668.0MHz), 133422 (693.0MHz) | 10MHz | QPSK | 1 Half Full |
| | | 133197 to 133397 | 133197 (670.5MHz), 133397 (690.5MHz) | 15MHz | QPSK | 1 Half Full |
| | | 133222 to 133372 | 133222 (673.0MHz), 133372 (688.0MHz) | 20MHz | QPSK | 1 Half Full |

| EUT Configure Mode | Test item | Available channel | Tested channel | Channel Bandwidth | Modulation | Mode |
|--------------------|------------------------------|-------------------|---|-------------------|-------------------------|------|
| - | Peak to Average Ratio | 133147 to 133447 | 133147 (665.5MHz), 133297 (680.5MHz), 133447 (695.5MHz) | 5MHz | QPSK / 16QAM / 64QAM | 1 |
| | | 133172 to 133422 | 133172 (668.0MHz), 133297 (680.5MHz), 133422 (693.0MHz) | 10MHz | QPSK / 16QAM / 64QAM | 1 |
| | | 133197 to 133397 | 133197 (670.5MHz), 133297 (680.5MHz), 133397 (690.5MHz) | 15MHz | QPSK / 16QAM / 64QAM | 1 |
| | | 133222 to 133372 | 133222 (673.0MHz), 133297 (680.5MHz), 133372 (688.0MHz) | 20MHz | QPSK / 16QAM / 64QAM | 1 |
| - | Conducted Emission | 133147 to 133447 | 133147 (665.5MHz), 133297 (680.5MHz), 133447 (695.5MHz) | 5MHz | QPSK | 1 |
| | | 133172 to 133422 | 133172 (668.0MHz), 133297 (680.5MHz), 133422 (693.0MHz) | 10MHz | QPSK | 1 |
| | | 133197 to 133397 | 133197 (670.5MHz), 133297 (680.5MHz), 133397 (690.5MHz) | 15MHz | QPSK | 1 |
| | | 133222 to 133372 | 133222 (673.0MHz), 133297 (680.5MHz), 133372 (688.0MHz) | 20MHz | QPSK | 1 |
| - | Radiated Emission Below 1GHz | 133222 to 133372 | 133372 (688.0MHz) | 20MHz | QPSK | 1 |
| - | Radiated Emission Above 1GHz | 133147 to 133447 | 133147 (665.5MHz), 133297 (680.5MHz), 133447 (695.5MHz) | 5MHz | QPSK | 1 |
| | | 133222 to 133372 | 133222 (673.0MHz), 133297 (680.5MHz), 133372 (688.0MHz) | 20MHz | QPSK | 1 |

Note:

1. For radiated emission below 1GHz, select the worst radiated emission channel (above 1GHz) for final testing.
2. For radiated emission above 1GHz, according to 3GPP 36.521-1 Section 6.6.3.1.4.1, choose the 5MHz & highest channel bandwidth for final test.
3. The output power for QPSK, 16QAM and 64QAM, measured value of QPSK is higher than 16QAM, and 64QAM mode. Therefore, only Modulation characteristics, occupied bandwidth and Peak to average ratio items had been tested under QPSK, 16QAM and 64QAM modes, the other test items were performed under worse mode according to the maximum output power.

Test Condition:

| Test Item | Environmental Conditions | Input Power | Tested By |
|----------------------------|--------------------------|-------------|------------|
| EIRP / ERP | 25deg. C, 60%RH | 4.0Vdc | Noah Chang |
| Modulation Characteristics | 25deg. C, 60%RH | 4.0Vdc | Noah Chang |
| Frequency Stability | 25deg. C, 60%RH | 4.0Vdc | Noah Chang |
| Occupied Bandwidth | 25deg. C, 60%RH | 4.0Vdc | Noah Chang |
| Band Edge | 25deg. C, 60%RH | 4.0Vdc | Noah Chang |
| Peak To Average Ratio | 25deg. C, 60%RH | 4.0Vdc | Noah Chang |
| Conducted Emission | 25deg. C, 60%RH | 4.0Vdc | Noah Chang |
| Radiated Emission | 21deg. C, 67%RH | 4.0Vdc | Edison Lee |

3.4 EUT Operating Conditions

The EUT makes a call to the communication simulator. The communication simulator station system controlled a EUT to export maximum output power under transmission mode and specific channel frequency

3.5 General Description of Applied Standards and References

The EUT is a RF Product. According to the specifications of the manufacturer, it must comply with the requirements of the following standards and References:

Test Standard:

FCC 47 CFR Part 2

FCC 47 CFR Part 27

ANSI/TIA/EIA-603-E 2016

ANSI 63.26-2015

References Test Guidance:

KDB 971168 D01 Power Meas License Digital Systems v03r01

All test items have been performed as a reference to the above KDB test guidance.

4 Test Types and Results

4.1 Output Power Measurement

4.1.1 Limits of Output Power Measurement

For LTE Band 4, LTE Band 66:

Mobile / Portable station are limited to 1 watts e.i.r.p.

For LTE Band 7:

Mobile stations are limited to 2.0 watts EIRP. All user stations are limited to 2.0 watts transmitter output power.

For LTE Band 12, LTE Band 17, LTE Band 71:

Control and mobile stations in the 698-746 MHz band are limited to 30 watts ERP.

Portable stations (hand-held devices) in the 600 MHz uplink band and the 698-746 MHz band, and fixed and mobile stations in the 600 MHz uplink, band are limited to 3 watts ERP.

4.1.2 Test Procedures

Conducted Power Measurement:

The EUT was set up for the maximum power with LTE link data modulation and link up with simulator. Set the EUT to transmit under low, middle and high channel and record the power level shown on simulator.

Maximum EIRP / ERP

The relevant equation for determining the maximum ERP or EIRP from the measured RF output power is given in Equation as follows:

$$\text{EIRP} = P_{\text{Meas}} + G_{\text{T}}$$

$$\text{ERP} = P_{\text{Meas}} + G_{\text{T}} - 2.15$$

where

ERP or EIRP effective radiated power or equivalent isotropically radiated power, respectively

(expressed in the same units as P_{Meas} , e.g., dBm or dBW)

P_{Meas} measured transmitter output power or PSD, in dBm or dBW

G_{T} gain of the transmitting antenna, in dBd (ERP) or dBi (EIRP)

4.1.3 Test Setup

Conducted Power Measurement:



4.1.4 Test Results

Conducted Output Power (dBm)

| LTE Band 4 | | | | | | |
|------------|-----------|-----------------|-----------|--------------|--------|-------|
| BW | MCS Index | RB Size | RB Offset | Low | Mid | High |
| | | Channel | | 20050 | 20175 | 20300 |
| | | Frequency (MHz) | | 1720 | 1732.5 | 1745 |
| 20M | QPSK | 1 | 0 | 22.83 | 22.83 | 22.79 |
| | | 1 | 50 | 22.92 | 22.91 | 22.88 |
| | | 1 | 99 | 22.90 | 22.87 | 22.80 |
| | | 50 | 0 | 21.87 | 21.90 | 21.82 |
| | | 50 | 25 | 21.92 | 21.88 | 21.89 |
| | | 50 | 50 | 21.81 | 21.91 | 21.94 |
| | | 100 | 0 | 21.76 | 21.85 | 21.83 |
| 20M | 16QAM | 1 | 0 | 21.93 | 21.90 | 21.82 |
| | | 1 | 50 | 21.99 | 21.94 | 21.93 |
| | | 1 | 99 | 21.93 | 21.97 | 21.81 |
| | | 50 | 0 | 20.93 | 20.91 | 20.92 |
| | | 50 | 25 | 20.96 | 20.97 | 20.93 |
| | | 50 | 50 | 20.82 | 20.97 | 21.01 |
| | | 100 | 0 | 20.83 | 20.95 | 20.92 |
| 20M | 64QAM | 1 | 0 | 20.83 | 20.90 | 20.82 |
| | | 1 | 50 | 20.99 | 20.93 | 20.92 |
| | | 1 | 99 | 20.92 | 20.89 | 20.73 |
| | | 50 | 0 | 19.89 | 19.84 | 19.87 |
| | | 50 | 25 | 19.87 | 19.93 | 19.90 |
| | | 50 | 50 | 19.76 | 19.95 | 19.92 |
| | | 100 | 0 | 19.76 | 19.95 | 19.88 |

| LTE Band 4 | | | | | | |
|------------|-----------|-----------------|-----------|--------|--------|--------------|
| BW | MCS Index | RB Size | RB Offset | Low | Mid | High |
| | | Channel | | 20025 | 20175 | 20325 |
| | | Frequency (MHz) | | 1717.5 | 1732.5 | 1747.5 |
| 15M | QPSK | 1 | 0 | 22.80 | 22.88 | 22.83 |
| | | 1 | 37 | 22.82 | 22.89 | 22.96 |
| | | 1 | 74 | 22.85 | 22.86 | 22.89 |
| | | 36 | 0 | 21.86 | 21.95 | 21.92 |
| | | 36 | 19 | 21.86 | 21.89 | 21.81 |
| | | 36 | 39 | 21.81 | 21.87 | 21.97 |
| | | 75 | 0 | 21.81 | 21.85 | 21.77 |
| 15M | 16QAM | 1 | 0 | 21.80 | 21.96 | 21.90 |
| | | 1 | 37 | 21.91 | 21.99 | 22.00 |
| | | 1 | 74 | 21.87 | 21.93 | 21.95 |
| | | 36 | 0 | 20.96 | 20.99 | 20.92 |
| | | 36 | 19 | 20.88 | 20.93 | 20.90 |
| | | 36 | 39 | 20.91 | 20.97 | 20.97 |
| | | 75 | 0 | 20.85 | 20.87 | 20.82 |
| 15M | 64QAM | 1 | 0 | 20.78 | 20.90 | 20.80 |
| | | 1 | 37 | 20.86 | 20.89 | 20.95 |
| | | 1 | 74 | 20.86 | 20.84 | 20.88 |
| | | 36 | 0 | 19.90 | 19.98 | 19.82 |
| | | 36 | 19 | 19.88 | 19.86 | 19.82 |
| | | 36 | 39 | 19.90 | 19.97 | 19.92 |
| | | 75 | 0 | 19.77 | 19.77 | 19.77 |

| LTE Band 4 | | | | | | |
|------------|-----------|-----------------|-----------|-------|--------------|-------|
| BW | MCS Index | RB Size | RB Offset | Low | Mid | High |
| | | Channel | | 20000 | 20175 | 20350 |
| | | Frequency (MHz) | | 1715 | 1732.5 | 1750 |
| 10M | QPSK | 1 | 0 | 22.93 | 22.94 | 22.88 |
| | | 1 | 24 | 22.82 | 22.90 | 22.82 |
| | | 1 | 49 | 22.90 | 22.89 | 22.88 |
| | | 25 | 0 | 21.88 | 21.93 | 21.96 |
| | | 25 | 12 | 21.91 | 21.84 | 21.85 |
| | | 25 | 25 | 22.09 | 22.00 | 21.91 |
| | | 50 | 0 | 21.91 | 21.92 | 22.02 |
| 10M | 16QAM | 1 | 0 | 21.93 | 22.04 | 21.95 |
| | | 1 | 24 | 21.83 | 21.98 | 21.83 |
| | | 1 | 49 | 21.93 | 21.89 | 21.88 |
| | | 25 | 0 | 20.97 | 20.94 | 20.99 |
| | | 25 | 12 | 20.97 | 20.91 | 20.85 |
| | | 25 | 25 | 21.11 | 21.00 | 20.96 |
| | | 50 | 0 | 20.97 | 21.02 | 21.11 |
| 10M | 64QAM | 1 | 0 | 20.85 | 21.02 | 20.85 |
| | | 1 | 24 | 20.81 | 20.96 | 20.82 |
| | | 1 | 49 | 20.86 | 20.89 | 20.82 |
| | | 25 | 0 | 19.87 | 19.88 | 19.96 |
| | | 25 | 12 | 19.87 | 19.88 | 19.82 |
| | | 25 | 25 | 20.04 | 19.90 | 19.88 |
| | | 50 | 0 | 19.88 | 19.97 | 20.01 |

| LTE Band 4 | | | | | | |
|------------|-----------|-----------------|-----------|--------------|--------|--------------|
| BW | MCS Index | RB Size | RB Offset | Low | Mid | High |
| | | Channel | | 19975 | 20175 | 20375 |
| | | Frequency (MHz) | | 1712.5 | 1732.5 | 1752.5 |
| 5M | QPSK | 1 | 0 | 23.06 | 22.99 | 23.06 |
| | | 1 | 12 | 22.90 | 22.93 | 22.97 |
| | | 1 | 24 | 22.80 | 22.87 | 22.85 |
| | | 12 | 0 | 21.85 | 21.85 | 21.86 |
| | | 12 | 6 | 21.88 | 21.88 | 21.84 |
| | | 12 | 13 | 21.85 | 21.92 | 21.95 |
| | | 25 | 0 | 22.03 | 21.93 | 21.94 |
| 5M | 16QAM | 1 | 0 | 22.06 | 22.09 | 22.10 |
| | | 1 | 12 | 21.98 | 22.00 | 21.97 |
| | | 1 | 24 | 21.82 | 21.94 | 21.95 |
| | | 12 | 0 | 20.92 | 20.85 | 20.90 |
| | | 12 | 6 | 20.94 | 20.88 | 20.89 |
| | | 12 | 13 | 20.89 | 20.95 | 20.95 |
| | | 25 | 0 | 21.03 | 21.02 | 20.99 |
| 5M | 64QAM | 1 | 0 | 21.03 | 21.02 | 21.08 |
| | | 1 | 12 | 20.93 | 20.99 | 20.88 |
| | | 1 | 24 | 20.78 | 20.86 | 20.92 |
| | | 12 | 0 | 19.82 | 19.80 | 19.84 |
| | | 12 | 6 | 19.92 | 19.78 | 19.82 |
| | | 12 | 13 | 19.89 | 19.90 | 19.94 |
| | | 25 | 0 | 19.95 | 20.01 | 19.99 |

| LTE Band 4 | | | | | | |
|------------|-----------|-----------------|-----------|--------|--------------|--------------|
| BW | MCS Index | RB Size | RB Offset | Low | Mid | High |
| | | Channel | | 19965 | 20175 | 20385 |
| | | Frequency (MHz) | | 1711.5 | 1732.5 | 1753.5 |
| 3M | QPSK | 1 | 0 | 22.83 | 22.88 | 22.93 |
| | | 1 | 7 | 22.84 | 22.93 | 22.86 |
| | | 1 | 14 | 22.92 | 22.86 | 22.89 |
| | | 8 | 0 | 21.88 | 21.83 | 21.93 |
| | | 8 | 3 | 22.00 | 22.01 | 21.91 |
| | | 8 | 7 | 21.77 | 21.85 | 21.94 |
| | | 15 | 0 | 21.92 | 21.92 | 21.97 |
| 3M | 16QAM | 1 | 0 | 21.84 | 21.95 | 21.98 |
| | | 1 | 7 | 21.86 | 22.00 | 21.87 |
| | | 1 | 14 | 21.92 | 21.96 | 21.94 |
| | | 8 | 0 | 20.91 | 20.87 | 21.01 |
| | | 8 | 3 | 21.00 | 21.01 | 20.94 |
| | | 8 | 7 | 20.85 | 20.94 | 21.00 |
| | | 15 | 0 | 21.01 | 20.95 | 21.07 |
| 3M | 64QAM | 1 | 0 | 20.76 | 20.95 | 20.89 |
| | | 1 | 7 | 20.81 | 20.91 | 20.79 |
| | | 1 | 14 | 20.87 | 20.87 | 20.87 |
| | | 8 | 0 | 19.81 | 19.77 | 19.97 |
| | | 8 | 3 | 19.98 | 19.95 | 19.92 |
| | | 8 | 7 | 19.79 | 19.92 | 19.91 |
| | | 15 | 0 | 19.93 | 19.88 | 20.01 |

| LTE Band 4 | | | | | | |
|------------|-----------|-----------------|-----------|--------|--------|--------------|
| BW | MCS Index | RB Size | RB Offset | Low | Mid | High |
| | | Channel | | 19957 | 20175 | 20393 |
| | | Frequency (MHz) | | 1710.7 | 1732.5 | 1754.3 |
| 1.4M | QPSK | 1 | 0 | 22.85 | 22.85 | 22.79 |
| | | 1 | 2 | 22.97 | 22.91 | 22.97 |
| | | 1 | 5 | 22.87 | 22.88 | 22.97 |
| | | 3 | 0 | 22.81 | 22.89 | 22.83 |
| | | 3 | 1 | 22.99 | 22.92 | 22.94 |
| | | 3 | 3 | 22.88 | 22.94 | 23.04 |
| | | 6 | 0 | 21.79 | 21.87 | 21.81 |
| 1.4M | 16QAM | 1 | 0 | 21.94 | 21.92 | 21.88 |
| | | 1 | 2 | 22.01 | 21.91 | 22.01 |
| | | 1 | 5 | 21.95 | 21.95 | 21.97 |
| | | 3 | 0 | 21.81 | 21.92 | 21.84 |
| | | 3 | 1 | 22.02 | 22.00 | 21.99 |
| | | 3 | 3 | 21.91 | 22.03 | 22.12 |
| | | 6 | 0 | 20.88 | 20.94 | 20.85 |
| 1.4M | 64QAM | 1 | 0 | 20.94 | 20.89 | 20.82 |
| | | 1 | 2 | 20.94 | 20.87 | 20.91 |
| | | 1 | 5 | 20.87 | 20.91 | 20.87 |
| | | 3 | 0 | 20.80 | 20.90 | 20.83 |
| | | 3 | 1 | 20.95 | 20.97 | 20.91 |
| | | 3 | 3 | 20.84 | 21.02 | 21.08 |
| | | 6 | 0 | 19.88 | 19.94 | 19.85 |

| LTE Band 7 | | | | | | |
|------------|-----------|-----------------|-----------|--------------|--------------|-------|
| BW | MCS Index | RB Size | RB Offset | Low | Mid | High |
| | | Channel | | 20850 | 21100 | 21350 |
| | | Frequency (MHz) | | 2510 | 2535 | 2560 |
| 20M | QPSK | 1 | 0 | 22.68 | 22.63 | 22.56 |
| | | 1 | 50 | 22.54 | 22.57 | 22.64 |
| | | 1 | 99 | 22.58 | 22.53 | 22.61 |
| | | 50 | 0 | 21.54 | 21.51 | 21.55 |
| | | 50 | 25 | 21.56 | 21.57 | 21.55 |
| | | 50 | 50 | 21.49 | 21.49 | 21.40 |
| | | 100 | 0 | 21.64 | 21.60 | 21.50 |
| 20M | 16QAM | 1 | 0 | 21.74 | 21.70 | 21.59 |
| | | 1 | 50 | 21.59 | 21.62 | 21.68 |
| | | 1 | 99 | 21.59 | 21.62 | 21.67 |
| | | 50 | 0 | 20.59 | 20.55 | 20.61 |
| | | 50 | 25 | 20.62 | 20.64 | 20.65 |
| | | 50 | 50 | 20.52 | 20.52 | 20.50 |
| | | 100 | 0 | 20.64 | 20.60 | 20.53 |
| 20M | 64QAM | 1 | 0 | 20.64 | 20.68 | 20.51 |
| | | 1 | 50 | 20.53 | 20.52 | 20.59 |
| | | 1 | 99 | 20.58 | 20.59 | 20.65 |
| | | 50 | 0 | 19.51 | 19.55 | 19.60 |
| | | 50 | 25 | 19.57 | 19.58 | 19.58 |
| | | 50 | 50 | 19.44 | 19.50 | 19.47 |
| | | 100 | 0 | 19.59 | 19.58 | 19.45 |

| LTE Band 7 | | | | | | |
|------------|-----------|-----------------|-----------|--------------|-------|--------------|
| BW | MCS Index | RB Size | RB Offset | Low | Mid | High |
| | | Channel | | 20825 | 21100 | 21375 |
| | | Frequency (MHz) | | 2507.5 | 2535 | 2562.5 |
| 15M | QPSK | 1 | 0 | 22.69 | 22.65 | 22.56 |
| | | 1 | 37 | 22.48 | 22.58 | 22.67 |
| | | 1 | 74 | 22.46 | 22.51 | 22.59 |
| | | 36 | 0 | 21.65 | 21.65 | 21.55 |
| | | 36 | 19 | 21.53 | 21.59 | 21.63 |
| | | 36 | 39 | 21.46 | 21.53 | 21.50 |
| | | 75 | 0 | 21.57 | 21.54 | 21.47 |
| 15M | 16QAM | 1 | 0 | 21.71 | 21.68 | 21.60 |
| | | 1 | 37 | 21.49 | 21.64 | 21.76 |
| | | 1 | 74 | 21.55 | 21.51 | 21.65 |
| | | 36 | 0 | 20.75 | 20.70 | 20.61 |
| | | 36 | 19 | 20.60 | 20.62 | 20.69 |
| | | 36 | 39 | 20.48 | 20.56 | 20.53 |
| | | 75 | 0 | 20.65 | 20.55 | 20.56 |
| 15M | 64QAM | 1 | 0 | 20.62 | 20.66 | 20.55 |
| | | 1 | 37 | 20.46 | 20.63 | 20.73 |
| | | 1 | 74 | 20.48 | 20.48 | 20.59 |
| | | 36 | 0 | 19.74 | 19.66 | 19.61 |
| | | 36 | 19 | 19.58 | 19.53 | 19.64 |
| | | 36 | 39 | 19.43 | 19.46 | 19.46 |
| | | 75 | 0 | 19.55 | 19.46 | 19.52 |

| LTE Band 7 | | | | | | |
|------------|-----------|-----------------|-----------|-------|-------|--------------|
| BW | MCS Index | RB Size | RB Offset | Low | Mid | High |
| | | Channel | | 20800 | 21100 | 21400 |
| | | Frequency (MHz) | | 2505 | 2535 | 2565 |
| 10M | QPSK | 1 | 0 | 22.62 | 22.65 | 22.67 |
| | | 1 | 24 | 22.54 | 22.56 | 22.50 |
| | | 1 | 49 | 22.46 | 22.55 | 22.51 |
| | | 25 | 0 | 21.69 | 21.62 | 21.64 |
| | | 25 | 12 | 21.54 | 21.59 | 21.53 |
| | | 25 | 25 | 21.54 | 21.60 | 21.64 |
| | | 50 | 0 | 21.50 | 21.58 | 21.63 |
| 10M | 16QAM | 1 | 0 | 21.62 | 21.67 | 21.72 |
| | | 1 | 24 | 21.62 | 21.66 | 21.59 |
| | | 1 | 49 | 21.49 | 21.65 | 21.57 |
| | | 25 | 0 | 20.76 | 20.72 | 20.72 |
| | | 25 | 12 | 20.55 | 20.60 | 20.60 |
| | | 25 | 25 | 20.59 | 20.66 | 20.71 |
| | | 50 | 0 | 20.59 | 20.63 | 20.69 |
| 10M | 64QAM | 1 | 0 | 20.55 | 20.60 | 20.66 |
| | | 1 | 24 | 20.54 | 20.58 | 20.52 |
| | | 1 | 49 | 20.48 | 20.55 | 20.54 |
| | | 25 | 0 | 19.73 | 19.72 | 19.72 |
| | | 25 | 12 | 19.51 | 19.59 | 19.57 |
| | | 25 | 25 | 19.49 | 19.59 | 19.64 |
| | | 50 | 0 | 19.58 | 19.56 | 19.61 |

| LTE Band 7 | | | | | | |
|------------|-----------|-----------------|-----------|--------|--------------|--------------|
| BW | MCS Index | RB Size | RB Offset | Low | Mid | High |
| | | Channel | | 20775 | 21100 | 21425 |
| | | Frequency (MHz) | | 2502.5 | 2535 | 2567.5 |
| 5M | QPSK | 1 | 0 | 22.52 | 22.61 | 22.63 |
| | | 1 | 12 | 22.56 | 22.59 | 22.61 |
| | | 1 | 24 | 22.47 | 22.57 | 22.56 |
| | | 12 | 0 | 21.58 | 21.64 | 21.61 |
| | | 12 | 6 | 21.57 | 21.66 | 21.74 |
| | | 12 | 13 | 21.69 | 21.62 | 21.65 |
| | | 25 | 0 | 21.64 | 21.56 | 21.50 |
| 5M | 16QAM | 1 | 0 | 21.58 | 21.64 | 21.68 |
| | | 1 | 12 | 21.64 | 21.69 | 21.69 |
| | | 1 | 24 | 21.52 | 21.62 | 21.60 |
| | | 12 | 0 | 20.58 | 20.72 | 20.67 |
| | | 12 | 6 | 20.67 | 20.67 | 20.83 |
| | | 12 | 13 | 20.76 | 20.69 | 20.71 |
| | | 25 | 0 | 20.70 | 20.57 | 20.51 |
| 5M | 64QAM | 1 | 0 | 20.49 | 20.62 | 20.67 |
| | | 1 | 12 | 20.55 | 20.68 | 20.61 |
| | | 1 | 24 | 20.48 | 20.56 | 20.55 |
| | | 12 | 0 | 19.56 | 19.63 | 19.66 |
| | | 12 | 6 | 19.66 | 19.62 | 19.76 |
| | | 12 | 13 | 19.72 | 19.60 | 19.63 |
| | | 25 | 0 | 19.60 | 19.54 | 19.47 |

| LTE Band 12 | | | | | | |
|-------------|-----------|-----------------|-----------|-------|-------|--------------|
| BW | MCS Index | RB Size | RB Offset | Low | Mid | High |
| | | Channel | | 23060 | 23095 | 23130 |
| | | Frequency (MHz) | | 704 | 707.5 | 711 |
| 10M | QPSK | 1 | 0 | 22.70 | 22.69 | 22.67 |
| | | 1 | 24 | 22.74 | 22.64 | 22.69 |
| | | 1 | 49 | 22.68 | 22.70 | 22.78 |
| | | 25 | 0 | 21.62 | 21.69 | 21.76 |
| | | 25 | 12 | 21.58 | 21.64 | 21.64 |
| | | 25 | 25 | 21.64 | 21.58 | 21.64 |
| | | 50 | 0 | 21.51 | 21.55 | 21.47 |
| 10M | 16QAM | 1 | 0 | 21.76 | 21.75 | 21.69 |
| | | 1 | 24 | 21.82 | 21.70 | 21.77 |
| | | 1 | 49 | 21.77 | 21.74 | 21.87 |
| | | 25 | 0 | 20.62 | 20.76 | 20.76 |
| | | 25 | 12 | 20.66 | 20.73 | 20.65 |
| | | 25 | 25 | 20.67 | 20.64 | 20.72 |
| | | 50 | 0 | 20.61 | 20.59 | 20.53 |
| 10M | 64QAM | 1 | 0 | 20.71 | 20.70 | 20.62 |
| | | 1 | 24 | 20.73 | 20.61 | 20.73 |
| | | 1 | 49 | 20.70 | 20.64 | 20.77 |
| | | 25 | 0 | 19.57 | 19.76 | 19.72 |
| | | 25 | 12 | 19.62 | 19.69 | 19.62 |
| | | 25 | 25 | 19.58 | 19.59 | 19.68 |
| | | 50 | 0 | 19.59 | 19.58 | 19.53 |

| LTE Band 12 | | | | | | |
|-------------|-----------|-----------------|-----------|--------------|-------|--------------|
| BW | MCS Index | RB Size | RB Offset | Low | Mid | High |
| | | Channel | | 23035 | 23095 | 23155 |
| | | Frequency (MHz) | | 701.5 | 707.5 | 713.5 |
| 5M | QPSK | 1 | 0 | 22.53 | 22.61 | 22.69 |
| | | 1 | 12 | 22.60 | 22.63 | 22.66 |
| | | 1 | 24 | 22.65 | 22.65 | 22.61 |
| | | 12 | 0 | 21.77 | 21.67 | 21.57 |
| | | 12 | 6 | 21.69 | 21.59 | 21.67 |
| | | 12 | 13 | 21.68 | 21.63 | 21.63 |
| | | 25 | 0 | 21.69 | 21.70 | 21.75 |
| 5M | 16QAM | 1 | 0 | 21.53 | 21.69 | 21.69 |
| | | 1 | 12 | 21.63 | 21.72 | 21.71 |
| | | 1 | 24 | 21.75 | 21.73 | 21.68 |
| | | 12 | 0 | 20.78 | 20.75 | 20.59 |
| | | 12 | 6 | 20.69 | 20.63 | 20.70 |
| | | 12 | 13 | 20.76 | 20.71 | 20.73 |
| | | 25 | 0 | 20.72 | 20.70 | 20.75 |
| 5M | 64QAM | 1 | 0 | 20.47 | 20.63 | 20.69 |
| | | 1 | 12 | 20.53 | 20.62 | 20.64 |
| | | 1 | 24 | 20.65 | 20.63 | 20.61 |
| | | 12 | 0 | 19.78 | 19.75 | 19.59 |
| | | 12 | 6 | 19.60 | 19.58 | 19.62 |
| | | 12 | 13 | 19.73 | 19.71 | 19.67 |
| | | 25 | 0 | 19.68 | 19.69 | 19.67 |

| LTE Band 12 | | | | | | |
|-------------|-----------|-----------------|-----------|-------|-------|-------|
| BW | MCS Index | RB Size | RB Offset | Low | Mid | High |
| | | Channel | | 23025 | 23095 | 23165 |
| | | Frequency (MHz) | | 700.5 | 707.5 | 714.5 |
| 3M | QPSK | 1 | 0 | 22.56 | 22.59 | 22.53 |
| | | 1 | 7 | 22.61 | 22.64 | 22.54 |
| | | 1 | 14 | 22.77 | 22.75 | 22.72 |
| | | 8 | 0 | 21.78 | 21.71 | 21.70 |
| | | 8 | 3 | 21.73 | 21.69 | 21.67 |
| | | 8 | 7 | 21.66 | 21.73 | 21.73 |
| | | 15 | 0 | 21.77 | 21.77 | 21.80 |
| 3M | 16QAM | 1 | 0 | 21.61 | 21.65 | 21.54 |
| | | 1 | 7 | 21.70 | 21.66 | 21.62 |
| | | 1 | 14 | 21.87 | 21.75 | 21.77 |
| | | 8 | 0 | 20.83 | 20.81 | 20.80 |
| | | 8 | 3 | 20.74 | 20.79 | 20.70 |
| | | 8 | 7 | 20.67 | 20.80 | 20.75 |
| | | 15 | 0 | 20.82 | 20.85 | 20.87 |
| 3M | 64QAM | 1 | 0 | 20.57 | 20.64 | 20.52 |
| | | 1 | 7 | 20.68 | 20.65 | 20.59 |
| | | 1 | 14 | 20.78 | 20.68 | 20.77 |
| | | 8 | 0 | 19.79 | 19.75 | 19.75 |
| | | 8 | 3 | 19.68 | 19.79 | 19.64 |
| | | 8 | 7 | 19.57 | 19.78 | 19.75 |
| | | 15 | 0 | 19.76 | 19.82 | 19.83 |

| LTE Band 12 | | | | | | |
|-------------|-----------|-----------------|-----------|-------|--------------|--------------|
| BW | MCS Index | RB Size | RB Offset | Low | Mid | High |
| | | Channel | | 23017 | 23095 | 23173 |
| | | Frequency (MHz) | | 699.7 | 707.5 | 715.3 |
| 1.4M | QPSK | 1 | 0 | 22.77 | 22.75 | 22.75 |
| | | 1 | 2 | 22.74 | 22.76 | 22.81 |
| | | 1 | 5 | 22.70 | 22.61 | 22.54 |
| | | 3 | 0 | 22.55 | 22.64 | 22.63 |
| | | 3 | 1 | 22.54 | 22.60 | 22.60 |
| | | 3 | 3 | 22.79 | 22.77 | 22.78 |
| | | 6 | 0 | 21.79 | 21.70 | 21.71 |
| 1.4M | 16QAM | 1 | 0 | 21.82 | 21.81 | 21.77 |
| | | 1 | 2 | 21.76 | 21.83 | 21.81 |
| | | 1 | 5 | 21.75 | 21.62 | 21.54 |
| | | 3 | 0 | 21.55 | 21.66 | 21.69 |
| | | 3 | 1 | 21.62 | 21.67 | 21.63 |
| | | 3 | 3 | 21.86 | 21.87 | 21.81 |
| | | 6 | 0 | 20.82 | 20.78 | 20.72 |
| 1.4M | 64QAM | 1 | 0 | 20.80 | 20.71 | 20.71 |
| | | 1 | 2 | 20.74 | 20.79 | 20.73 |
| | | 1 | 5 | 20.67 | 20.62 | 20.51 |
| | | 3 | 0 | 20.51 | 20.63 | 20.59 |
| | | 3 | 1 | 20.52 | 20.66 | 20.57 |
| | | 3 | 3 | 20.80 | 20.84 | 20.75 |
| | | 6 | 0 | 19.72 | 19.69 | 19.67 |

| LTE Band 17 | | | | | | |
|-------------|-----------|-----------------|-----------|--------------|-------|-------|
| BW | MCS Index | RB Size | RB Offset | Low | Mid | High |
| | | Channel | | 23780 | 23790 | 23800 |
| | | Frequency (MHz) | | 709 | 710 | 711 |
| 10M | QPSK | 1 | 0 | 22.76 | 22.75 | 22.75 |
| | | 1 | 24 | 22.89 | 22.88 | 22.80 |
| | | 1 | 49 | 22.88 | 22.87 | 22.77 |
| | | 25 | 0 | 21.81 | 21.83 | 21.91 |
| | | 25 | 12 | 21.81 | 21.89 | 21.92 |
| | | 25 | 25 | 22.01 | 21.93 | 22.03 |
| | | 50 | 0 | 21.82 | 21.90 | 21.80 |
| 10M | 16QAM | 1 | 0 | 21.79 | 21.85 | 21.76 |
| | | 1 | 24 | 21.96 | 21.92 | 21.82 |
| | | 1 | 49 | 21.94 | 21.88 | 21.84 |
| | | 25 | 0 | 20.91 | 20.91 | 20.98 |
| | | 25 | 12 | 20.83 | 20.89 | 20.98 |
| | | 25 | 25 | 21.01 | 20.98 | 21.10 |
| | | 50 | 0 | 20.84 | 21.00 | 20.80 |
| 10M | 64QAM | 1 | 0 | 20.78 | 20.75 | 20.69 |
| | | 1 | 24 | 20.91 | 20.87 | 20.72 |
| | | 1 | 49 | 20.86 | 20.84 | 20.75 |
| | | 25 | 0 | 19.91 | 19.88 | 19.95 |
| | | 25 | 12 | 19.79 | 19.86 | 19.90 |
| | | 25 | 25 | 19.98 | 19.95 | 20.00 |
| | | 50 | 0 | 19.74 | 19.99 | 19.80 |

| LTE Band 17 | | | | | | |
|-------------|-----------|-----------------|-----------|--------------|-------|-------|
| BW | MCS Index | RB Size | RB Offset | Low | Mid | High |
| | | Channel | | 23755 | 23790 | 23825 |
| | | Frequency (MHz) | | 706.5 | 710 | 713.5 |
| 5M | QPSK | 1 | 0 | 22.81 | 22.79 | 22.82 |
| | | 1 | 12 | 22.91 | 22.85 | 22.77 |
| | | 1 | 24 | 22.87 | 22.86 | 22.76 |
| | | 12 | 0 | 21.78 | 21.86 | 21.76 |
| | | 12 | 6 | 21.98 | 21.94 | 22.01 |
| | | 12 | 13 | 21.84 | 21.80 | 21.78 |
| | | 25 | 0 | 21.90 | 21.85 | 21.77 |
| 5M | 16QAM | 1 | 0 | 21.86 | 21.86 | 21.83 |
| | | 1 | 12 | 22.01 | 21.91 | 21.87 |
| | | 1 | 24 | 21.93 | 21.90 | 21.85 |
| | | 12 | 0 | 20.83 | 20.95 | 20.85 |
| | | 12 | 6 | 21.07 | 21.04 | 21.01 |
| | | 12 | 13 | 20.84 | 20.81 | 20.80 |
| | | 25 | 0 | 20.95 | 20.88 | 20.79 |
| 5M | 64QAM | 1 | 0 | 20.78 | 20.85 | 20.80 |
| | | 1 | 12 | 21.00 | 20.84 | 20.78 |
| | | 1 | 24 | 20.92 | 20.81 | 20.85 |
| | | 12 | 0 | 19.82 | 19.89 | 19.84 |
| | | 12 | 6 | 19.99 | 20.04 | 19.95 |
| | | 12 | 13 | 19.79 | 19.77 | 19.78 |
| | | 25 | 0 | 19.85 | 19.82 | 19.70 |

| LTE Band 66 | | | | | | |
|-------------|-----------|-----------------|-----------|--------------|--------|--------|
| BW | MCS Index | RB Size | RB Offset | Low | Mid | High |
| | | Channel | | 132072 | 132322 | 132572 |
| | | Frequency (MHz) | | 1720 | 1745 | 1770 |
| 20M | QPSK | 1 | 0 | 22.86 | 22.81 | 22.74 |
| | | 1 | 50 | 22.80 | 22.78 | 22.82 |
| | | 1 | 99 | 22.83 | 22.79 | 22.69 |
| | | 50 | 0 | 21.54 | 21.63 | 21.62 |
| | | 50 | 25 | 21.58 | 21.65 | 21.59 |
| | | 50 | 50 | 21.64 | 21.73 | 21.73 |
| | | 100 | 0 | 21.75 | 21.72 | 21.69 |
| 20M | 16QAM | 1 | 0 | 21.95 | 21.90 | 21.80 |
| | | 1 | 50 | 21.86 | 21.86 | 21.88 |
| | | 1 | 99 | 21.85 | 21.88 | 21.70 |
| | | 50 | 0 | 20.64 | 20.73 | 20.69 |
| | | 50 | 25 | 20.64 | 20.72 | 20.66 |
| | | 50 | 50 | 20.64 | 20.74 | 20.76 |
| | | 100 | 0 | 20.84 | 20.82 | 20.77 |
| 20M | 64QAM | 1 | 0 | 20.95 | 20.88 | 20.76 |
| | | 1 | 50 | 20.83 | 20.80 | 20.84 |
| | | 1 | 99 | 20.75 | 20.80 | 20.63 |
| | | 50 | 0 | 19.64 | 19.72 | 19.62 |
| | | 50 | 25 | 19.58 | 19.65 | 19.57 |
| | | 50 | 50 | 19.61 | 19.71 | 19.72 |
| | | 100 | 0 | 19.77 | 19.78 | 19.73 |

| LTE Band 66 | | | | | | |
|-------------|-----------|-----------------|-----------|--------------|--------|--------------|
| BW | MCS Index | RB Size | RB Offset | Low | Mid | High |
| | | Channel | | 132047 | 132322 | 132597 |
| | | Frequency (MHz) | | 1717.5 | 1745 | 1772.5 |
| 15M | QPSK | 1 | 0 | 22.85 | 22.79 | 22.80 |
| | | 1 | 37 | 22.72 | 22.81 | 22.87 |
| | | 1 | 74 | 22.86 | 22.83 | 22.89 |
| | | 36 | 0 | 21.63 | 21.65 | 21.67 |
| | | 36 | 19 | 21.68 | 21.69 | 21.70 |
| | | 36 | 39 | 21.71 | 21.71 | 21.74 |
| | | 75 | 0 | 21.69 | 21.67 | 21.63 |
| 15M | 16QAM | 1 | 0 | 21.90 | 21.79 | 21.84 |
| | | 1 | 37 | 21.79 | 21.90 | 21.88 |
| | | 1 | 74 | 21.93 | 21.91 | 21.99 |
| | | 36 | 0 | 20.68 | 20.72 | 20.67 |
| | | 36 | 19 | 20.77 | 20.71 | 20.80 |
| | | 36 | 39 | 20.75 | 20.81 | 20.79 |
| | | 75 | 0 | 20.74 | 20.71 | 20.68 |
| 15M | 64QAM | 1 | 0 | 20.90 | 20.75 | 20.77 |
| | | 1 | 37 | 20.79 | 20.80 | 20.83 |
| | | 1 | 74 | 20.90 | 20.89 | 20.89 |
| | | 36 | 0 | 19.65 | 19.72 | 19.57 |
| | | 36 | 19 | 19.73 | 19.71 | 19.73 |
| | | 36 | 39 | 19.66 | 19.71 | 19.71 |
| | | 75 | 0 | 19.69 | 19.61 | 19.61 |

| LTE Band 66 | | | | | | |
|-------------|-----------|-----------------|-----------|--------------|--------|--------------|
| BW | MCS Index | RB Size | RB Offset | Low | Mid | High |
| | | Channel | | 132022 | 132322 | 132622 |
| | | Frequency (MHz) | | 1715 | 1745 | 1775 |
| 10M | QPSK | 1 | 0 | 22.75 | 22.75 | 22.68 |
| | | 1 | 24 | 22.89 | 22.80 | 22.85 |
| | | 1 | 49 | 22.75 | 22.82 | 22.72 |
| | | 25 | 0 | 21.55 | 21.65 | 21.72 |
| | | 25 | 12 | 21.66 | 21.69 | 21.73 |
| | | 25 | 25 | 21.67 | 21.70 | 21.68 |
| | | 50 | 0 | 21.69 | 21.76 | 21.66 |
| 10M | 16QAM | 1 | 0 | 21.85 | 21.77 | 21.78 |
| | | 1 | 24 | 21.93 | 21.90 | 21.85 |
| | | 1 | 49 | 21.75 | 21.91 | 21.79 |
| | | 25 | 0 | 20.61 | 20.67 | 20.81 |
| | | 25 | 12 | 20.72 | 20.75 | 20.77 |
| | | 25 | 25 | 20.76 | 20.72 | 20.70 |
| | | 50 | 0 | 20.74 | 20.86 | 20.72 |
| 10M | 64QAM | 1 | 0 | 20.79 | 20.73 | 20.68 |
| | | 1 | 24 | 20.85 | 20.84 | 20.85 |
| | | 1 | 49 | 20.65 | 20.84 | 20.74 |
| | | 25 | 0 | 19.54 | 19.61 | 19.72 |
| | | 25 | 12 | 19.63 | 19.73 | 19.71 |
| | | 25 | 25 | 19.67 | 19.65 | 19.60 |
| | | 50 | 0 | 19.66 | 19.77 | 19.68 |

| LTE Band 66 | | | | | | |
|-------------|-----------|-----------------|-----------|--------|--------|--------------|
| BW | MCS Index | RB Size | RB Offset | Low | Mid | High |
| | | Channel | | 131997 | 132322 | 132647 |
| | | Frequency (MHz) | | 1712.5 | 1745 | 1777.5 |
| 5M | QPSK | 1 | 0 | 22.72 | 22.79 | 22.70 |
| | | 1 | 12 | 22.84 | 22.83 | 22.93 |
| | | 1 | 24 | 22.79 | 22.81 | 22.72 |
| | | 12 | 0 | 21.66 | 21.65 | 21.59 |
| | | 12 | 6 | 21.57 | 21.63 | 21.62 |
| | | 12 | 13 | 21.71 | 21.71 | 21.77 |
| | | 25 | 0 | 21.69 | 21.73 | 21.64 |
| 5M | 16QAM | 1 | 0 | 21.73 | 21.83 | 21.73 |
| | | 1 | 12 | 21.92 | 21.90 | 21.97 |
| | | 1 | 24 | 21.79 | 21.89 | 21.74 |
| | | 12 | 0 | 20.70 | 20.73 | 20.63 |
| | | 12 | 6 | 20.60 | 20.71 | 20.67 |
| | | 12 | 13 | 20.72 | 20.73 | 20.85 |
| | | 25 | 0 | 20.75 | 20.76 | 20.66 |
| 5M | 64QAM | 1 | 0 | 20.73 | 20.75 | 20.72 |
| | | 1 | 12 | 20.90 | 20.88 | 20.95 |
| | | 1 | 24 | 20.73 | 20.80 | 20.69 |
| | | 12 | 0 | 19.62 | 19.71 | 19.54 |
| | | 12 | 6 | 19.50 | 19.69 | 19.61 |
| | | 12 | 13 | 19.63 | 19.67 | 19.75 |
| | | 25 | 0 | 19.65 | 19.76 | 19.66 |

| LTE Band 66 | | | | | | |
|-------------|-----------|-----------------|-----------|--------------|--------------|--------|
| BW | MCS Index | RB Size | RB Offset | Low | Mid | High |
| | | Channel | | 131987 | 132322 | 132657 |
| | | Frequency (MHz) | | 1711.5 | 1745 | 1778.5 |
| 3M | QPSK | 1 | 0 | 22.75 | 22.79 | 22.82 |
| | | 1 | 7 | 22.88 | 22.81 | 22.82 |
| | | 1 | 14 | 22.77 | 22.83 | 22.81 |
| | | 8 | 0 | 21.74 | 21.65 | 21.62 |
| | | 8 | 3 | 21.76 | 21.69 | 21.76 |
| | | 8 | 7 | 21.71 | 21.63 | 21.70 |
| | | 15 | 0 | 21.72 | 21.70 | 21.76 |
| 3M | 16QAM | 1 | 0 | 21.81 | 21.83 | 21.89 |
| | | 1 | 7 | 21.90 | 21.90 | 21.85 |
| | | 1 | 14 | 21.82 | 21.88 | 21.83 |
| | | 8 | 0 | 20.81 | 20.67 | 20.67 |
| | | 8 | 3 | 20.78 | 20.79 | 20.77 |
| | | 8 | 7 | 20.73 | 20.64 | 20.74 |
| | | 15 | 0 | 20.72 | 20.79 | 20.80 |
| 3M | 64QAM | 1 | 0 | 20.71 | 20.78 | 20.84 |
| | | 1 | 7 | 20.82 | 20.87 | 20.79 |
| | | 1 | 14 | 20.74 | 20.81 | 20.81 |
| | | 8 | 0 | 19.71 | 19.64 | 19.61 |
| | | 8 | 3 | 19.70 | 19.73 | 19.77 |
| | | 8 | 7 | 19.66 | 19.61 | 19.70 |
| | | 15 | 0 | 19.65 | 19.71 | 19.79 |

| LTE Band 66 | | | | | | |
|-------------|-----------|-----------------|-----------|--------|--------|--------------|
| BW | MCS Index | RB Size | RB Offset | Low | Mid | High |
| | | Channel | | 131979 | 132322 | 132665 |
| | | Frequency (MHz) | | 1710.7 | 1745 | 1779.3 |
| 1.4M | QPSK | 1 | 0 | 22.85 | 22.75 | 22.73 |
| | | 1 | 2 | 22.81 | 22.80 | 22.88 |
| | | 1 | 5 | 22.73 | 22.73 | 22.81 |
| | | 3 | 0 | 22.61 | 22.69 | 22.59 |
| | | 3 | 1 | 22.78 | 22.79 | 22.69 |
| | | 3 | 3 | 22.83 | 22.75 | 22.83 |
| | | 6 | 0 | 21.66 | 21.64 | 21.60 |
| 1.4M | 16QAM | 1 | 0 | 21.94 | 21.82 | 21.82 |
| | | 1 | 2 | 21.88 | 21.81 | 21.98 |
| | | 1 | 5 | 21.74 | 21.82 | 21.87 |
| | | 3 | 0 | 21.68 | 21.79 | 21.60 |
| | | 3 | 1 | 21.80 | 21.82 | 21.77 |
| | | 3 | 3 | 21.84 | 21.81 | 21.85 |
| | | 6 | 0 | 20.72 | 20.68 | 20.70 |
| 1.4M | 64QAM | 1 | 0 | 20.92 | 20.80 | 20.81 |
| | | 1 | 2 | 20.78 | 20.75 | 20.95 |
| | | 1 | 5 | 20.66 | 20.80 | 20.85 |
| | | 3 | 0 | 20.65 | 20.74 | 20.56 |
| | | 3 | 1 | 20.73 | 20.78 | 20.74 |
| | | 3 | 3 | 20.74 | 20.72 | 20.81 |
| | | 6 | 0 | 19.69 | 19.61 | 19.62 |

| LTE Band 71 | | | | | | |
|-------------|-----------|-----------------|-----------|--------|--------|--------|
| BW | MCS Index | RB Size | RB Offset | Low | Mid | High |
| | | Channel | | 133222 | 133297 | 133372 |
| | | Frequency (MHz) | | 673 | 680.5 | 688 |
| 20M | QPSK | 1 | 0 | 23.11 | 23.16 | 23.09 |
| | | 1 | 50 | 23.10 | 23.15 | 23.13 |
| | | 1 | 99 | 23.17 | 23.10 | 23.17 |
| | | 50 | 0 | 22.22 | 22.16 | 22.16 |
| | | 50 | 25 | 22.26 | 22.21 | 22.28 |
| | | 50 | 50 | 22.11 | 22.19 | 22.24 |
| | | 100 | 0 | 22.24 | 22.23 | 22.21 |
| 20M | 16QAM | 1 | 0 | 22.20 | 22.23 | 22.17 |
| | | 1 | 50 | 22.14 | 22.16 | 22.14 |
| | | 1 | 99 | 22.21 | 22.15 | 22.18 |
| | | 50 | 0 | 21.30 | 21.25 | 21.18 |
| | | 50 | 25 | 21.29 | 21.25 | 21.33 |
| | | 50 | 50 | 21.19 | 21.27 | 21.26 |
| | | 100 | 0 | 21.26 | 21.24 | 21.28 |
| 20M | 64QAM | 1 | 0 | 21.12 | 21.14 | 21.08 |
| | | 1 | 50 | 21.13 | 21.10 | 21.05 |
| | | 1 | 99 | 21.11 | 21.11 | 21.11 |
| | | 50 | 0 | 20.23 | 20.23 | 20.15 |
| | | 50 | 25 | 20.26 | 20.21 | 20.24 |
| | | 50 | 50 | 20.10 | 20.26 | 20.16 |
| | | 100 | 0 | 20.20 | 20.21 | 20.19 |

| LTE Band 71 | | | | | | |
|-------------|-----------|-----------------|-----------|--------|--------|--------------|
| BW | MCS Index | RB Size | RB Offset | Low | Mid | High |
| | | Channel | | 133197 | 133297 | 133397 |
| | | Frequency (MHz) | | 670.5 | 680.5 | 690.5 |
| 15M | QPSK | 1 | 0 | 23.24 | 23.29 | 23.32 |
| | | 1 | 37 | 23.13 | 23.16 | 23.11 |
| | | 1 | 74 | 23.15 | 23.20 | 23.15 |
| | | 36 | 0 | 22.22 | 22.16 | 22.24 |
| | | 36 | 19 | 22.18 | 22.21 | 22.29 |
| | | 36 | 39 | 22.23 | 22.19 | 22.15 |
| | | 75 | 0 | 22.22 | 22.21 | 22.11 |
| 15M | 16QAM | 1 | 0 | 22.34 | 22.29 | 22.41 |
| | | 1 | 37 | 22.20 | 22.18 | 22.17 |
| | | 1 | 74 | 22.18 | 22.29 | 22.16 |
| | | 36 | 0 | 21.30 | 21.19 | 21.28 |
| | | 36 | 19 | 21.25 | 21.31 | 21.29 |
| | | 36 | 39 | 21.26 | 21.28 | 21.16 |
| | | 75 | 0 | 21.24 | 21.25 | 21.15 |
| 15M | 64QAM | 1 | 0 | 21.28 | 21.21 | 21.31 |
| | | 1 | 37 | 21.16 | 21.17 | 21.08 |
| | | 1 | 74 | 21.16 | 21.29 | 21.12 |
| | | 36 | 0 | 20.29 | 20.12 | 20.19 |
| | | 36 | 19 | 20.19 | 20.27 | 20.21 |
| | | 36 | 39 | 20.22 | 20.22 | 20.10 |
| | | 75 | 0 | 20.24 | 20.18 | 20.05 |

| LTE Band 71 | | | | | | |
|-------------|-----------|-----------------|-----------|--------|--------|--------------|
| BW | MCS Index | RB Size | RB Offset | Low | Mid | High |
| | | Channel | | 133172 | 133297 | 133422 |
| | | Frequency (MHz) | | 668 | 680.5 | 693 |
| 10M | QPSK | 1 | 0 | 23.20 | 23.19 | 23.29 |
| | | 1 | 24 | 23.26 | 23.21 | 23.11 |
| | | 1 | 49 | 23.19 | 23.19 | 23.13 |
| | | 25 | 0 | 22.18 | 22.16 | 22.06 |
| | | 25 | 12 | 22.26 | 22.20 | 22.18 |
| | | 25 | 25 | 22.20 | 22.16 | 22.08 |
| | | 50 | 0 | 22.11 | 22.13 | 22.10 |
| 10M | 16QAM | 1 | 0 | 22.20 | 22.21 | 22.30 |
| | | 1 | 24 | 22.27 | 22.22 | 22.14 |
| | | 1 | 49 | 22.20 | 22.25 | 22.17 |
| | | 25 | 0 | 21.21 | 21.26 | 21.10 |
| | | 25 | 12 | 21.36 | 21.26 | 21.21 |
| | | 25 | 25 | 21.28 | 21.23 | 21.15 |
| | | 50 | 0 | 21.15 | 21.20 | 21.17 |
| 10M | 64QAM | 1 | 0 | 21.20 | 21.11 | 21.30 |
| | | 1 | 24 | 21.19 | 21.21 | 21.12 |
| | | 1 | 49 | 21.17 | 21.25 | 21.16 |
| | | 25 | 0 | 20.18 | 20.26 | 20.03 |
| | | 25 | 12 | 20.30 | 20.23 | 20.14 |
| | | 25 | 25 | 20.21 | 20.20 | 20.15 |
| | | 50 | 0 | 20.14 | 20.17 | 20.13 |

| LTE Band 71 | | | | | | |
|-------------|-----------|-----------------|-----------|--------|--------|--------|
| BW | MCS Index | RB Size | RB Offset | Low | Mid | High |
| | | Channel | | 133147 | 133297 | 133447 |
| | | Frequency (MHz) | | 665.5 | 680.5 | 695.5 |
| 5M | QPSK | 1 | 0 | 23.20 | 23.15 | 23.05 |
| | | 1 | 12 | 23.15 | 23.12 | 23.19 |
| | | 1 | 24 | 23.11 | 23.03 | 23.02 |
| | | 12 | 0 | 22.03 | 22.10 | 22.02 |
| | | 12 | 6 | 22.25 | 22.19 | 22.26 |
| | | 12 | 13 | 22.13 | 22.06 | 22.07 |
| | | 25 | 0 | 22.08 | 22.13 | 22.03 |
| 5M | 16QAM | 1 | 0 | 22.22 | 22.23 | 22.11 |
| | | 1 | 12 | 22.25 | 22.20 | 22.21 |
| | | 1 | 24 | 22.12 | 22.07 | 22.05 |
| | | 12 | 0 | 21.12 | 21.20 | 21.05 |
| | | 12 | 6 | 21.26 | 21.29 | 21.27 |
| | | 12 | 13 | 21.15 | 21.08 | 21.09 |
| | | 25 | 0 | 21.16 | 21.23 | 21.05 |
| 5M | 64QAM | 1 | 0 | 21.13 | 21.22 | 21.04 |
| | | 1 | 12 | 21.16 | 21.12 | 21.20 |
| | | 1 | 24 | 21.04 | 21.03 | 20.97 |
| | | 12 | 0 | 20.05 | 20.18 | 20.02 |
| | | 12 | 6 | 20.26 | 20.29 | 20.18 |
| | | 12 | 13 | 20.06 | 19.98 | 20.06 |
| | | 25 | 0 | 20.12 | 20.14 | 20.03 |

EIRP / ERP Power (dBm)

| LTE Band 4 | | | | | | |
|------------|-----------|-----------------|-----------|--------------|--------|-------|
| BW | MCS Index | RB Size | RB Offset | Low | Mid | High |
| | | Channel | | 20050 | 20175 | 20300 |
| | | Frequency (MHz) | | 1720 | 1732.5 | 1745 |
| 20M | QPSK | 1 | 0 | 24.40 | 24.40 | 24.36 |
| | | 1 | 50 | 24.49 | 24.48 | 24.45 |
| | | 1 | 99 | 24.47 | 24.44 | 24.37 |
| | | 50 | 0 | 23.44 | 23.47 | 23.39 |
| | | 50 | 25 | 23.49 | 23.45 | 23.46 |
| | | 50 | 50 | 23.38 | 23.48 | 23.51 |
| | | 100 | 0 | 23.33 | 23.42 | 23.40 |
| 20M | 16QAM | 1 | 0 | 23.50 | 23.47 | 23.39 |
| | | 1 | 50 | 23.56 | 23.51 | 23.50 |
| | | 1 | 99 | 23.50 | 23.54 | 23.38 |
| | | 50 | 0 | 22.50 | 22.48 | 22.49 |
| | | 50 | 25 | 22.53 | 22.54 | 22.50 |
| | | 50 | 50 | 22.39 | 22.54 | 22.58 |
| | | 100 | 0 | 22.40 | 22.52 | 22.49 |
| 20M | 64QAM | 1 | 0 | 22.40 | 22.47 | 22.39 |
| | | 1 | 50 | 22.56 | 22.50 | 22.49 |
| | | 1 | 99 | 22.49 | 22.46 | 22.30 |
| | | 50 | 0 | 21.46 | 21.41 | 21.44 |
| | | 50 | 25 | 21.44 | 21.50 | 21.47 |
| | | 50 | 50 | 21.33 | 21.52 | 21.49 |
| | | 100 | 0 | 21.33 | 21.52 | 21.45 |

*EIRP = Conducted + antenna gain (1.57dBi)

| LTE Band 4 | | | | | | |
|------------|-----------|-----------------|-----------|--------|--------|--------------|
| BW | MCS Index | RB Size | RB Offset | Low | Mid | High |
| | | Channel | | 20025 | 20175 | 20325 |
| | | Frequency (MHz) | | 1717.5 | 1732.5 | 1747.5 |
| 15M | QPSK | 1 | 0 | 24.37 | 24.45 | 24.40 |
| | | 1 | 37 | 24.39 | 24.46 | 24.53 |
| | | 1 | 74 | 24.42 | 24.43 | 24.46 |
| | | 36 | 0 | 23.43 | 23.52 | 23.49 |
| | | 36 | 19 | 23.43 | 23.46 | 23.38 |
| | | 36 | 39 | 23.38 | 23.44 | 23.54 |
| | | 75 | 0 | 23.38 | 23.42 | 23.34 |
| 15M | 16QAM | 1 | 0 | 23.37 | 23.53 | 23.47 |
| | | 1 | 37 | 23.48 | 23.56 | 23.57 |
| | | 1 | 74 | 23.44 | 23.50 | 23.52 |
| | | 36 | 0 | 22.53 | 22.56 | 22.49 |
| | | 36 | 19 | 22.45 | 22.50 | 22.47 |
| | | 36 | 39 | 22.48 | 22.54 | 22.54 |
| | | 75 | 0 | 22.42 | 22.44 | 22.39 |
| 15M | 64QAM | 1 | 0 | 22.35 | 22.47 | 22.37 |
| | | 1 | 37 | 22.43 | 22.46 | 22.52 |
| | | 1 | 74 | 22.43 | 22.41 | 22.45 |
| | | 36 | 0 | 21.47 | 21.55 | 21.39 |
| | | 36 | 19 | 21.45 | 21.43 | 21.39 |
| | | 36 | 39 | 21.47 | 21.54 | 21.49 |
| | | 75 | 0 | 21.34 | 21.34 | 21.34 |

*EIRP = Conducted + antenna gain (1.57dBi)

| LTE Band 4 | | | | | | |
|------------|-----------|-----------------|-----------|-------|--------------|-------|
| BW | MCS Index | RB Size | RB Offset | Low | Mid | High |
| | | Channel | | 20000 | 20175 | 20350 |
| | | Frequency (MHz) | | 1715 | 1732.5 | 1750 |
| 10M | QPSK | 1 | 0 | 24.50 | 24.51 | 24.45 |
| | | 1 | 24 | 24.39 | 24.47 | 24.39 |
| | | 1 | 49 | 24.47 | 24.46 | 24.45 |
| | | 25 | 0 | 23.45 | 23.50 | 23.53 |
| | | 25 | 12 | 23.48 | 23.41 | 23.42 |
| | | 25 | 25 | 23.66 | 23.57 | 23.48 |
| | | 50 | 0 | 23.48 | 23.49 | 23.59 |
| 10M | 16QAM | 1 | 0 | 23.50 | 23.61 | 23.52 |
| | | 1 | 24 | 23.40 | 23.55 | 23.40 |
| | | 1 | 49 | 23.50 | 23.46 | 23.45 |
| | | 25 | 0 | 22.54 | 22.51 | 22.56 |
| | | 25 | 12 | 22.54 | 22.48 | 22.42 |
| | | 25 | 25 | 22.68 | 22.57 | 22.53 |
| | | 50 | 0 | 22.54 | 22.59 | 22.68 |
| 10M | 64QAM | 1 | 0 | 22.42 | 22.59 | 22.42 |
| | | 1 | 24 | 22.38 | 22.53 | 22.39 |
| | | 1 | 49 | 22.43 | 22.46 | 22.39 |
| | | 25 | 0 | 21.44 | 21.45 | 21.53 |
| | | 25 | 12 | 21.44 | 21.45 | 21.39 |
| | | 25 | 25 | 21.61 | 21.47 | 21.45 |
| | | 50 | 0 | 21.45 | 21.54 | 21.58 |

*EIRP = Conducted + antenna gain (1.57dBi)

| LTE Band 4 | | | | | | |
|------------|-----------|-----------------|-----------|--------------|--------|--------------|
| BW | MCS Index | RB Size | RB Offset | Low | Mid | High |
| | | Channel | | 19975 | 20175 | 20375 |
| | | Frequency (MHz) | | 1712.5 | 1732.5 | 1752.5 |
| 5M | QPSK | 1 | 0 | 24.63 | 24.56 | 24.63 |
| | | 1 | 12 | 24.47 | 24.50 | 24.54 |
| | | 1 | 24 | 24.37 | 24.44 | 24.42 |
| | | 12 | 0 | 23.42 | 23.42 | 23.43 |
| | | 12 | 6 | 23.45 | 23.45 | 23.41 |
| | | 12 | 13 | 23.42 | 23.49 | 23.52 |
| | | 25 | 0 | 23.60 | 23.50 | 23.51 |
| 5M | 16QAM | 1 | 0 | 23.63 | 23.66 | 23.67 |
| | | 1 | 12 | 23.55 | 23.57 | 23.54 |
| | | 1 | 24 | 23.39 | 23.51 | 23.52 |
| | | 12 | 0 | 22.49 | 22.42 | 22.47 |
| | | 12 | 6 | 22.51 | 22.45 | 22.46 |
| | | 12 | 13 | 22.46 | 22.52 | 22.52 |
| | | 25 | 0 | 22.60 | 22.59 | 22.56 |
| 5M | 64QAM | 1 | 0 | 22.60 | 22.59 | 22.65 |
| | | 1 | 12 | 22.50 | 22.56 | 22.45 |
| | | 1 | 24 | 22.35 | 22.43 | 22.49 |
| | | 12 | 0 | 21.39 | 21.37 | 21.41 |
| | | 12 | 6 | 21.49 | 21.35 | 21.39 |
| | | 12 | 13 | 21.46 | 21.47 | 21.51 |
| | | 25 | 0 | 21.52 | 21.58 | 21.56 |

*EIRP = Conducted + antenna gain (1.57dBi)

| LTE Band 4 | | | | | | |
|------------|-----------|-----------------|-----------|--------|--------------|--------------|
| BW | MCS Index | RB Size | RB Offset | Low | Mid | High |
| | | Channel | | 19965 | 20175 | 20385 |
| | | Frequency (MHz) | | 1711.5 | 1732.5 | 1753.5 |
| 3M | QPSK | 1 | 0 | 24.40 | 24.45 | 24.50 |
| | | 1 | 7 | 24.41 | 24.50 | 24.43 |
| | | 1 | 14 | 24.49 | 24.43 | 24.46 |
| | | 8 | 0 | 23.45 | 23.40 | 23.50 |
| | | 8 | 3 | 23.57 | 23.58 | 23.48 |
| | | 8 | 7 | 23.34 | 23.42 | 23.51 |
| | | 15 | 0 | 23.49 | 23.49 | 23.54 |
| 3M | 16QAM | 1 | 0 | 23.41 | 23.52 | 23.55 |
| | | 1 | 7 | 23.43 | 23.57 | 23.44 |
| | | 1 | 14 | 23.49 | 23.53 | 23.51 |
| | | 8 | 0 | 22.48 | 22.44 | 22.58 |
| | | 8 | 3 | 22.57 | 22.58 | 22.51 |
| | | 8 | 7 | 22.42 | 22.51 | 22.57 |
| | | 15 | 0 | 22.58 | 22.52 | 22.64 |
| 3M | 64QAM | 1 | 0 | 22.33 | 22.52 | 22.46 |
| | | 1 | 7 | 22.38 | 22.48 | 22.36 |
| | | 1 | 14 | 22.44 | 22.44 | 22.44 |
| | | 8 | 0 | 21.38 | 21.34 | 21.54 |
| | | 8 | 3 | 21.55 | 21.52 | 21.49 |
| | | 8 | 7 | 21.36 | 21.49 | 21.48 |
| | | 15 | 0 | 21.50 | 21.45 | 21.58 |

*EIRP = Conducted + antenna gain (1.57dBi)

| LTE Band 4 | | | | | | |
|------------|-----------|-----------------|-----------|--------|--------|--------------|
| BW | MCS Index | RB Size | RB Offset | Low | Mid | High |
| | | Channel | | 19957 | 20175 | 20393 |
| | | Frequency (MHz) | | 1710.7 | 1732.5 | 1754.3 |
| 1.4M | QPSK | 1 | 0 | 24.42 | 24.42 | 24.36 |
| | | 1 | 2 | 24.54 | 24.48 | 24.54 |
| | | 1 | 5 | 24.44 | 24.45 | 24.54 |
| | | 3 | 0 | 24.38 | 24.46 | 24.40 |
| | | 3 | 1 | 24.56 | 24.49 | 24.51 |
| | | 3 | 3 | 24.45 | 24.51 | 24.61 |
| | | 6 | 0 | 23.36 | 23.44 | 23.38 |
| 1.4M | 16QAM | 1 | 0 | 23.51 | 23.49 | 23.45 |
| | | 1 | 2 | 23.58 | 23.48 | 23.58 |
| | | 1 | 5 | 23.52 | 23.52 | 23.54 |
| | | 3 | 0 | 23.38 | 23.49 | 23.41 |
| | | 3 | 1 | 23.59 | 23.57 | 23.56 |
| | | 3 | 3 | 23.48 | 23.60 | 23.69 |
| | | 6 | 0 | 22.45 | 22.51 | 22.42 |
| 1.4M | 64QAM | 1 | 0 | 22.51 | 22.46 | 22.39 |
| | | 1 | 2 | 22.51 | 22.44 | 22.48 |
| | | 1 | 5 | 22.44 | 22.48 | 22.44 |
| | | 3 | 0 | 22.37 | 22.47 | 22.40 |
| | | 3 | 1 | 22.52 | 22.54 | 22.48 |
| | | 3 | 3 | 22.41 | 22.59 | 22.65 |
| | | 6 | 0 | 21.45 | 21.51 | 21.42 |

*EIRP = Conducted + antenna gain (1.57dBi)

| LTE Band 7 | | | | | | |
|------------|-----------|-----------------|-----------|-------|-------|-------|
| BW | MCS Index | RB Size | RB Offset | Low | Mid | High |
| | | Channel | | 20850 | 21100 | 21350 |
| | | Frequency (MHz) | | 2510 | 2535 | 2560 |
| 20M | QPSK | 1 | 0 | 24.83 | 24.78 | 24.71 |
| | | 1 | 50 | 24.69 | 24.72 | 24.79 |
| | | 1 | 99 | 24.73 | 24.68 | 24.76 |
| | | 50 | 0 | 23.69 | 23.66 | 23.70 |
| | | 50 | 25 | 23.71 | 23.72 | 23.70 |
| | | 50 | 50 | 23.64 | 23.64 | 23.55 |
| | | 100 | 0 | 23.79 | 23.75 | 23.65 |
| 20M | 16QAM | 1 | 0 | 23.89 | 23.85 | 23.74 |
| | | 1 | 50 | 23.74 | 23.77 | 23.83 |
| | | 1 | 99 | 23.74 | 23.77 | 23.82 |
| | | 50 | 0 | 22.74 | 22.70 | 22.76 |
| | | 50 | 25 | 22.77 | 22.79 | 22.80 |
| | | 50 | 50 | 22.67 | 22.67 | 22.65 |
| | | 100 | 0 | 22.79 | 22.75 | 22.68 |
| 20M | 64QAM | 1 | 0 | 22.79 | 22.83 | 22.66 |
| | | 1 | 50 | 22.68 | 22.67 | 22.74 |
| | | 1 | 99 | 22.73 | 22.74 | 22.80 |
| | | 50 | 0 | 21.66 | 21.70 | 21.75 |
| | | 50 | 25 | 21.72 | 21.73 | 21.73 |
| | | 50 | 50 | 21.59 | 21.65 | 21.62 |
| | | 100 | 0 | 21.74 | 21.73 | 21.60 |

*EIRP = Conducted + antenna gain (2.15dBi)

| LTE Band 7 | | | | | | |
|------------|-----------|-----------------|-----------|--------------|-------|--------------|
| BW | MCS Index | RB Size | RB Offset | Low | Mid | High |
| | | Channel | | 20825 | 21100 | 21375 |
| | | Frequency (MHz) | | 2507.5 | 2535 | 2562.5 |
| 15M | QPSK | 1 | 0 | 24.84 | 24.80 | 24.71 |
| | | 1 | 37 | 24.63 | 24.73 | 24.82 |
| | | 1 | 74 | 24.61 | 24.66 | 24.74 |
| | | 36 | 0 | 23.80 | 23.80 | 23.70 |
| | | 36 | 19 | 23.68 | 23.74 | 23.78 |
| | | 36 | 39 | 23.61 | 23.68 | 23.65 |
| | | 75 | 0 | 23.72 | 23.69 | 23.62 |
| 15M | 16QAM | 1 | 0 | 23.86 | 23.83 | 23.75 |
| | | 1 | 37 | 23.64 | 23.79 | 23.91 |
| | | 1 | 74 | 23.70 | 23.66 | 23.80 |
| | | 36 | 0 | 22.90 | 22.85 | 22.76 |
| | | 36 | 19 | 22.75 | 22.77 | 22.84 |
| | | 36 | 39 | 22.63 | 22.71 | 22.68 |
| | | 75 | 0 | 22.80 | 22.70 | 22.71 |
| 15M | 64QAM | 1 | 0 | 22.77 | 22.81 | 22.70 |
| | | 1 | 37 | 22.61 | 22.78 | 22.88 |
| | | 1 | 74 | 22.63 | 22.63 | 22.74 |
| | | 36 | 0 | 21.89 | 21.81 | 21.76 |
| | | 36 | 19 | 21.73 | 21.68 | 21.79 |
| | | 36 | 39 | 21.58 | 21.61 | 21.61 |
| | | 75 | 0 | 21.70 | 21.61 | 21.67 |

*EIRP = Conducted + antenna gain (2.15dBi)

| LTE Band 7 | | | | | | |
|------------|-----------|-----------------|-----------|-------|-------|--------------|
| BW | MCS Index | RB Size | RB Offset | Low | Mid | High |
| | | Channel | | 20800 | 21100 | 21400 |
| | | Frequency (MHz) | | 2505 | 2535 | 2565 |
| 10M | QPSK | 1 | 0 | 24.77 | 24.80 | 24.82 |
| | | 1 | 24 | 24.69 | 24.71 | 24.65 |
| | | 1 | 49 | 24.61 | 24.70 | 24.66 |
| | | 25 | 0 | 23.84 | 23.77 | 23.79 |
| | | 25 | 12 | 23.69 | 23.74 | 23.68 |
| | | 25 | 25 | 23.69 | 23.75 | 23.79 |
| | | 50 | 0 | 23.65 | 23.73 | 23.78 |
| 10M | 16QAM | 1 | 0 | 23.77 | 23.82 | 23.87 |
| | | 1 | 24 | 23.77 | 23.81 | 23.74 |
| | | 1 | 49 | 23.64 | 23.80 | 23.72 |
| | | 25 | 0 | 22.91 | 22.87 | 22.87 |
| | | 25 | 12 | 22.70 | 22.75 | 22.75 |
| | | 25 | 25 | 22.74 | 22.81 | 22.86 |
| | | 50 | 0 | 22.74 | 22.78 | 22.84 |
| 10M | 64QAM | 1 | 0 | 22.70 | 22.75 | 22.81 |
| | | 1 | 24 | 22.69 | 22.73 | 22.67 |
| | | 1 | 49 | 22.63 | 22.70 | 22.69 |
| | | 25 | 0 | 21.88 | 21.87 | 21.87 |
| | | 25 | 12 | 21.66 | 21.74 | 21.72 |
| | | 25 | 25 | 21.64 | 21.74 | 21.79 |
| | | 50 | 0 | 21.73 | 21.71 | 21.76 |

*EIRP = Conducted + antenna gain (2.15dBi)

| LTE Band 7 | | | | | | |
|------------|-----------|-----------------|-----------|--------|--------------|--------------|
| BW | MCS Index | RB Size | RB Offset | Low | Mid | High |
| | | Channel | | 20775 | 21100 | 21425 |
| | | Frequency (MHz) | | 2502.5 | 2535 | 2567.5 |
| 5M | QPSK | 1 | 0 | 24.67 | 24.76 | 24.78 |
| | | 1 | 12 | 24.71 | 24.74 | 24.76 |
| | | 1 | 24 | 24.62 | 24.72 | 24.71 |
| | | 12 | 0 | 23.73 | 23.79 | 23.76 |
| | | 12 | 6 | 23.72 | 23.81 | 23.89 |
| | | 12 | 13 | 23.84 | 23.77 | 23.80 |
| | | 25 | 0 | 23.79 | 23.71 | 23.65 |
| 5M | 16QAM | 1 | 0 | 23.73 | 23.79 | 23.83 |
| | | 1 | 12 | 23.79 | 23.84 | 23.84 |
| | | 1 | 24 | 23.67 | 23.77 | 23.75 |
| | | 12 | 0 | 22.73 | 22.87 | 22.82 |
| | | 12 | 6 | 22.82 | 22.82 | 22.98 |
| | | 12 | 13 | 22.91 | 22.84 | 22.86 |
| | | 25 | 0 | 22.85 | 22.72 | 22.66 |
| 5M | 64QAM | 1 | 0 | 22.64 | 22.77 | 22.82 |
| | | 1 | 12 | 22.70 | 22.83 | 22.76 |
| | | 1 | 24 | 22.63 | 22.71 | 22.70 |
| | | 12 | 0 | 21.71 | 21.78 | 21.81 |
| | | 12 | 6 | 21.81 | 21.77 | 21.91 |
| | | 12 | 13 | 21.87 | 21.75 | 21.78 |
| | | 25 | 0 | 21.75 | 21.69 | 21.62 |

*EIRP = Conducted + antenna gain (2.15dBi)

| LTE Band 12 | | | | | | |
|-------------|-----------|-----------------|-----------|-------|-------|--------------|
| BW | MCS Index | RB Size | RB Offset | Low | Mid | High |
| | | Channel | | 23060 | 23095 | 23130 |
| | | Frequency (MHz) | | 704 | 707.5 | 711 |
| 10M | QPSK | 1 | 0 | 22.57 | 22.56 | 22.54 |
| | | 1 | 24 | 22.61 | 22.51 | 22.56 |
| | | 1 | 49 | 22.55 | 22.57 | 22.65 |
| | | 25 | 0 | 21.49 | 21.56 | 21.63 |
| | | 25 | 12 | 21.45 | 21.51 | 21.51 |
| | | 25 | 25 | 21.51 | 21.45 | 21.51 |
| | | 50 | 0 | 21.38 | 21.42 | 21.34 |
| 10M | 16QAM | 1 | 0 | 21.63 | 21.62 | 21.56 |
| | | 1 | 24 | 21.69 | 21.57 | 21.64 |
| | | 1 | 49 | 21.64 | 21.61 | 21.74 |
| | | 25 | 0 | 20.49 | 20.63 | 20.63 |
| | | 25 | 12 | 20.53 | 20.60 | 20.52 |
| | | 25 | 25 | 20.54 | 20.51 | 20.59 |
| | | 50 | 0 | 20.48 | 20.46 | 20.40 |
| 10M | 64QAM | 1 | 0 | 20.58 | 20.57 | 20.49 |
| | | 1 | 24 | 20.60 | 20.48 | 20.60 |
| | | 1 | 49 | 20.57 | 20.51 | 20.64 |
| | | 25 | 0 | 19.44 | 19.63 | 19.59 |
| | | 25 | 12 | 19.49 | 19.56 | 19.49 |
| | | 25 | 25 | 19.45 | 19.46 | 19.55 |
| | | 50 | 0 | 19.46 | 19.45 | 19.40 |

*ERP = Conducted + antenna gain (2.02dBi)-2.15

| LTE Band 12 | | | | | | |
|-------------|-----------|-----------------|-----------|--------------|-------|--------------|
| BW | MCS Index | RB Size | RB Offset | Low | Mid | High |
| | | Channel | | 23035 | 23095 | 23155 |
| | | Frequency (MHz) | | 701.5 | 707.5 | 713.5 |
| 5M | QPSK | 1 | 0 | 22.40 | 22.48 | 22.56 |
| | | 1 | 12 | 22.47 | 22.50 | 22.53 |
| | | 1 | 24 | 22.52 | 22.52 | 22.48 |
| | | 12 | 0 | 21.64 | 21.54 | 21.44 |
| | | 12 | 6 | 21.56 | 21.46 | 21.54 |
| | | 12 | 13 | 21.55 | 21.50 | 21.50 |
| | | 25 | 0 | 21.56 | 21.57 | 21.62 |
| 5M | 16QAM | 1 | 0 | 21.40 | 21.56 | 21.56 |
| | | 1 | 12 | 21.50 | 21.59 | 21.58 |
| | | 1 | 24 | 21.62 | 21.60 | 21.55 |
| | | 12 | 0 | 20.65 | 20.62 | 20.46 |
| | | 12 | 6 | 20.56 | 20.50 | 20.57 |
| | | 12 | 13 | 20.63 | 20.58 | 20.60 |
| | | 25 | 0 | 20.59 | 20.57 | 20.62 |
| 5M | 64QAM | 1 | 0 | 20.34 | 20.50 | 20.56 |
| | | 1 | 12 | 20.40 | 20.49 | 20.51 |
| | | 1 | 24 | 20.52 | 20.50 | 20.48 |
| | | 12 | 0 | 19.65 | 19.62 | 19.46 |
| | | 12 | 6 | 19.47 | 19.45 | 19.49 |
| | | 12 | 13 | 19.60 | 19.58 | 19.54 |
| | | 25 | 0 | 19.55 | 19.56 | 19.54 |

*ERP = Conducted + antenna gain (2.02dBi)-2.15

| LTE Band 12 | | | | | | |
|-------------|-----------|-----------------|-----------|--------------|-------|-------|
| BW | MCS Index | RB Size | RB Offset | Low | Mid | High |
| | | Channel | | 23025 | 23095 | 23165 |
| | | Frequency (MHz) | | 700.5 | 707.5 | 714.5 |
| 3M | QPSK | 1 | 0 | 22.43 | 22.46 | 22.40 |
| | | 1 | 7 | 22.48 | 22.51 | 22.41 |
| | | 1 | 14 | 22.64 | 22.62 | 22.59 |
| | | 8 | 0 | 21.65 | 21.58 | 21.57 |
| | | 8 | 3 | 21.60 | 21.56 | 21.54 |
| | | 8 | 7 | 21.53 | 21.60 | 21.60 |
| | | 15 | 0 | 21.64 | 21.64 | 21.67 |
| 3M | 16QAM | 1 | 0 | 21.48 | 21.52 | 21.41 |
| | | 1 | 7 | 21.57 | 21.53 | 21.49 |
| | | 1 | 14 | 21.74 | 21.62 | 21.64 |
| | | 8 | 0 | 20.70 | 20.68 | 20.67 |
| | | 8 | 3 | 20.61 | 20.66 | 20.57 |
| | | 8 | 7 | 20.54 | 20.67 | 20.62 |
| | | 15 | 0 | 20.69 | 20.72 | 20.74 |
| 3M | 64QAM | 1 | 0 | 20.44 | 20.51 | 20.39 |
| | | 1 | 7 | 20.55 | 20.52 | 20.46 |
| | | 1 | 14 | 20.65 | 20.55 | 20.64 |
| | | 8 | 0 | 19.66 | 19.62 | 19.62 |
| | | 8 | 3 | 19.55 | 19.66 | 19.51 |
| | | 8 | 7 | 19.44 | 19.65 | 19.62 |
| | | 15 | 0 | 19.63 | 19.69 | 19.70 |

*ERP = Conducted + antenna gain (2.02dBi)-2.15

| LTE Band 12 | | | | | | |
|-------------|-----------|-----------------|-----------|-------|--------------|--------------|
| BW | MCS Index | RB Size | RB Offset | Low | Mid | High |
| | | Channel | | 23017 | 23095 | 23173 |
| | | Frequency (MHz) | | 699.7 | 707.5 | 715.3 |
| 1.4M | QPSK | 1 | 0 | 22.64 | 22.62 | 22.62 |
| | | 1 | 2 | 22.61 | 22.63 | 22.68 |
| | | 1 | 5 | 22.57 | 22.48 | 22.41 |
| | | 3 | 0 | 22.42 | 22.51 | 22.50 |
| | | 3 | 1 | 22.41 | 22.47 | 22.47 |
| | | 3 | 3 | 22.66 | 22.64 | 22.65 |
| | | 6 | 0 | 21.66 | 21.57 | 21.58 |
| 1.4M | 16QAM | 1 | 0 | 21.69 | 21.68 | 21.64 |
| | | 1 | 2 | 21.63 | 21.70 | 21.68 |
| | | 1 | 5 | 21.62 | 21.49 | 21.41 |
| | | 3 | 0 | 21.42 | 21.53 | 21.56 |
| | | 3 | 1 | 21.49 | 21.54 | 21.50 |
| | | 3 | 3 | 21.73 | 21.74 | 21.68 |
| | | 6 | 0 | 20.69 | 20.65 | 20.59 |
| 1.4M | 64QAM | 1 | 0 | 20.67 | 20.58 | 20.58 |
| | | 1 | 2 | 20.61 | 20.66 | 20.60 |
| | | 1 | 5 | 20.54 | 20.49 | 20.38 |
| | | 3 | 0 | 20.38 | 20.50 | 20.46 |
| | | 3 | 1 | 20.39 | 20.53 | 20.44 |
| | | 3 | 3 | 20.67 | 20.71 | 20.62 |
| | | 6 | 0 | 19.59 | 19.56 | 19.54 |

*ERP = Conducted + antenna gain (2.02dBi)-2.15

| LTE Band 17 | | | | | | |
|-------------|-----------|-----------------|-----------|--------------|-------|-------|
| BW | MCS Index | RB Size | RB Offset | Low | Mid | High |
| | | Channel | | 23780 | 23790 | 23800 |
| | | Frequency (MHz) | | 709 | 710 | 711 |
| 10M | QPSK | 1 | 0 | 22.63 | 22.62 | 22.62 |
| | | 1 | 12 | 22.76 | 22.75 | 22.67 |
| | | 1 | 24 | 22.75 | 22.74 | 22.64 |
| | | 12 | 0 | 21.68 | 21.70 | 21.78 |
| | | 12 | 6 | 21.68 | 21.76 | 21.79 |
| | | 12 | 13 | 21.88 | 21.80 | 21.90 |
| | | 25 | 0 | 21.69 | 21.77 | 21.67 |
| 10M | 16QAM | 1 | 0 | 21.66 | 21.72 | 21.63 |
| | | 1 | 12 | 21.83 | 21.79 | 21.69 |
| | | 1 | 24 | 21.81 | 21.75 | 21.71 |
| | | 12 | 0 | 20.78 | 20.78 | 20.85 |
| | | 12 | 6 | 20.70 | 20.76 | 20.85 |
| | | 12 | 13 | 20.88 | 20.85 | 20.97 |
| | | 25 | 0 | 20.71 | 20.87 | 20.67 |
| 10M | 64QAM | 1 | 0 | 20.65 | 20.62 | 20.56 |
| | | 1 | 12 | 20.78 | 20.74 | 20.59 |
| | | 1 | 24 | 20.73 | 20.71 | 20.62 |
| | | 12 | 0 | 19.78 | 19.75 | 19.82 |
| | | 12 | 6 | 19.66 | 19.73 | 19.77 |
| | | 12 | 13 | 19.85 | 19.82 | 19.87 |
| | | 25 | 0 | 19.61 | 19.86 | 19.67 |

*ERP = Conducted + antenna gain (2.02dBi)-2.15

| LTE Band 17 | | | | | | |
|-------------|-----------|-----------------|-----------|--------------|-------|-------|
| BW | MCS Index | RB Size | RB Offset | Low | Mid | High |
| | | Channel | | 23755 | 23790 | 23825 |
| | | Frequency (MHz) | | 706.5 | 710 | 713.5 |
| 5M | QPSK | 1 | 0 | 22.68 | 22.66 | 22.69 |
| | | 1 | 12 | 22.78 | 22.72 | 22.64 |
| | | 1 | 24 | 22.74 | 22.73 | 22.63 |
| | | 12 | 0 | 21.65 | 21.73 | 21.63 |
| | | 12 | 6 | 21.85 | 21.81 | 21.88 |
| | | 12 | 13 | 21.71 | 21.67 | 21.65 |
| | | 25 | 0 | 21.77 | 21.72 | 21.64 |
| 5M | 16QAM | 1 | 0 | 21.73 | 21.73 | 21.70 |
| | | 1 | 12 | 21.88 | 21.78 | 21.74 |
| | | 1 | 24 | 21.80 | 21.77 | 21.72 |
| | | 12 | 0 | 20.70 | 20.82 | 20.72 |
| | | 12 | 6 | 20.94 | 20.91 | 20.88 |
| | | 12 | 13 | 20.71 | 20.68 | 20.67 |
| | | 25 | 0 | 20.82 | 20.75 | 20.66 |
| 5M | 64QAM | 1 | 0 | 20.65 | 20.72 | 20.67 |
| | | 1 | 12 | 20.87 | 20.71 | 20.65 |
| | | 1 | 24 | 20.79 | 20.68 | 20.72 |
| | | 12 | 0 | 19.69 | 19.76 | 19.71 |
| | | 12 | 6 | 19.86 | 19.91 | 19.82 |
| | | 12 | 13 | 19.66 | 19.64 | 19.65 |
| | | 25 | 0 | 19.72 | 19.69 | 19.57 |

*ERP = Conducted + antenna gain (2.02dBi)-2.15

| LTE Band 66 | | | | | | |
|-------------|-----------|-----------------|-----------|--------------|--------|--------|
| BW | MCS Index | RB Size | RB Offset | Low | Mid | High |
| | | Channel | | 132072 | 132322 | 132572 |
| | | Frequency (MHz) | | 1720 | 1745 | 1770 |
| 20M | QPSK | 1 | 0 | 24.43 | 24.38 | 24.31 |
| | | 1 | 50 | 24.37 | 24.35 | 24.39 |
| | | 1 | 99 | 24.40 | 24.36 | 24.26 |
| | | 50 | 0 | 23.11 | 23.20 | 23.19 |
| | | 50 | 25 | 23.15 | 23.22 | 23.16 |
| | | 50 | 50 | 23.21 | 23.30 | 23.30 |
| | | 100 | 0 | 23.32 | 23.29 | 23.26 |
| 20M | 16QAM | 1 | 0 | 23.52 | 23.47 | 23.37 |
| | | 1 | 50 | 23.43 | 23.43 | 23.45 |
| | | 1 | 99 | 23.42 | 23.45 | 23.27 |
| | | 50 | 0 | 22.21 | 22.30 | 22.26 |
| | | 50 | 25 | 22.21 | 22.29 | 22.23 |
| | | 50 | 50 | 22.21 | 22.31 | 22.33 |
| | | 100 | 0 | 22.41 | 22.39 | 22.34 |
| 20M | 64QAM | 1 | 0 | 22.52 | 22.45 | 22.33 |
| | | 1 | 50 | 22.40 | 22.37 | 22.41 |
| | | 1 | 99 | 22.32 | 22.37 | 22.20 |
| | | 50 | 0 | 21.21 | 21.29 | 21.19 |
| | | 50 | 25 | 21.15 | 21.22 | 21.14 |
| | | 50 | 50 | 21.18 | 21.28 | 21.29 |
| | | 100 | 0 | 21.34 | 21.35 | 21.30 |

*EIRP = Conducted + antenna gain (1.57dBi)

| LTE Band 66 | | | | | | |
|-------------|-----------|-----------------|-----------|--------------|--------|--------------|
| BW | MCS Index | RB Size | RB Offset | Low | Mid | High |
| | | Channel | | 132047 | 132322 | 132597 |
| | | Frequency (MHz) | | 1717.5 | 1745 | 1772.5 |
| 15M | QPSK | 1 | 0 | 24.42 | 24.36 | 24.37 |
| | | 1 | 37 | 24.29 | 24.38 | 24.44 |
| | | 1 | 74 | 24.43 | 24.40 | 24.46 |
| | | 36 | 0 | 23.20 | 23.22 | 23.24 |
| | | 36 | 19 | 23.25 | 23.26 | 23.27 |
| | | 36 | 39 | 23.28 | 23.28 | 23.31 |
| | | 75 | 0 | 23.26 | 23.24 | 23.20 |
| 15M | 16QAM | 1 | 0 | 23.47 | 23.36 | 23.41 |
| | | 1 | 37 | 23.36 | 23.47 | 23.45 |
| | | 1 | 74 | 23.50 | 23.48 | 23.56 |
| | | 36 | 0 | 22.25 | 22.29 | 22.24 |
| | | 36 | 19 | 22.34 | 22.28 | 22.37 |
| | | 36 | 39 | 22.32 | 22.38 | 22.36 |
| | | 75 | 0 | 22.31 | 22.28 | 22.25 |
| 15M | 64QAM | 1 | 0 | 22.47 | 22.32 | 22.34 |
| | | 1 | 37 | 22.36 | 22.37 | 22.40 |
| | | 1 | 74 | 22.47 | 22.46 | 22.46 |
| | | 36 | 0 | 21.22 | 21.29 | 21.14 |
| | | 36 | 19 | 21.30 | 21.28 | 21.30 |
| | | 36 | 39 | 21.23 | 21.28 | 21.28 |
| | | 75 | 0 | 21.26 | 21.18 | 21.18 |

*EIRP = Conducted + antenna gain (1.57dBi)

| LTE Band 66 | | | | | | |
|-------------|-----------|-----------------|-----------|--------------|--------|--------------|
| BW | MCS Index | RB Size | RB Offset | Low | Mid | High |
| | | Channel | | 132022 | 132322 | 132622 |
| | | Frequency (MHz) | | 1715 | 1745 | 1775 |
| 10M | QPSK | 1 | 0 | 24.32 | 24.32 | 24.25 |
| | | 1 | 24 | 24.46 | 24.37 | 24.42 |
| | | 1 | 49 | 24.32 | 24.39 | 24.29 |
| | | 25 | 0 | 23.12 | 23.22 | 23.29 |
| | | 25 | 12 | 23.23 | 23.26 | 23.30 |
| | | 25 | 25 | 23.24 | 23.27 | 23.25 |
| | | 50 | 0 | 23.26 | 23.33 | 23.23 |
| 10M | 16QAM | 1 | 0 | 23.42 | 23.34 | 23.35 |
| | | 1 | 24 | 23.50 | 23.47 | 23.42 |
| | | 1 | 49 | 23.32 | 23.48 | 23.36 |
| | | 25 | 0 | 22.18 | 22.24 | 22.38 |
| | | 25 | 12 | 22.29 | 22.32 | 22.34 |
| | | 25 | 25 | 22.33 | 22.29 | 22.27 |
| | | 50 | 0 | 22.31 | 22.43 | 22.29 |
| 10M | 64QAM | 1 | 0 | 22.36 | 22.30 | 22.25 |
| | | 1 | 24 | 22.42 | 22.41 | 22.42 |
| | | 1 | 49 | 22.22 | 22.41 | 22.31 |
| | | 25 | 0 | 21.11 | 21.18 | 21.29 |
| | | 25 | 12 | 21.20 | 21.30 | 21.28 |
| | | 25 | 25 | 21.24 | 21.22 | 21.17 |
| | | 50 | 0 | 21.23 | 21.34 | 21.25 |

*EIRP = Conducted + antenna gain (1.57dBi)

| LTE Band 66 | | | | | | |
|-------------|-----------|-----------------|-----------|--------|--------|--------------|
| BW | MCS Index | RB Size | RB Offset | Low | Mid | High |
| | | Channel | | 131997 | 132322 | 132647 |
| | | Frequency (MHz) | | 1712.5 | 1745 | 1777.5 |
| 5M | QPSK | 1 | 0 | 24.29 | 24.36 | 24.27 |
| | | 1 | 12 | 24.41 | 24.40 | 24.50 |
| | | 1 | 24 | 24.36 | 24.38 | 24.29 |
| | | 12 | 0 | 23.23 | 23.22 | 23.16 |
| | | 12 | 6 | 23.14 | 23.20 | 23.19 |
| | | 12 | 13 | 23.28 | 23.28 | 23.34 |
| | | 25 | 0 | 23.26 | 23.30 | 23.21 |
| 5M | 16QAM | 1 | 0 | 23.30 | 23.40 | 23.30 |
| | | 1 | 12 | 23.49 | 23.47 | 23.54 |
| | | 1 | 24 | 23.36 | 23.46 | 23.31 |
| | | 12 | 0 | 22.27 | 22.30 | 22.20 |
| | | 12 | 6 | 22.17 | 22.28 | 22.24 |
| | | 12 | 13 | 22.29 | 22.30 | 22.42 |
| | | 25 | 0 | 22.32 | 22.33 | 22.23 |
| 5M | 64QAM | 1 | 0 | 22.30 | 22.32 | 22.29 |
| | | 1 | 12 | 22.47 | 22.45 | 22.52 |
| | | 1 | 24 | 22.30 | 22.37 | 22.26 |
| | | 12 | 0 | 21.19 | 21.28 | 21.11 |
| | | 12 | 6 | 21.07 | 21.26 | 21.18 |
| | | 12 | 13 | 21.20 | 21.24 | 21.32 |
| | | 25 | 0 | 21.22 | 21.33 | 21.23 |

*EIRP = Conducted + antenna gain (1.57dBi)

| LTE Band 66 | | | | | | |
|-------------|-----------|-----------------|-----------|--------|--------|--------|
| BW | MCS Index | RB Size | RB Offset | Low | Mid | High |
| | | Channel | | 131987 | 132322 | 132657 |
| | | Frequency (MHz) | | 1711.5 | 1745 | 1778.5 |
| 3M | QPSK | 1 | 0 | 24.32 | 24.36 | 24.39 |
| | | 1 | 7 | 24.45 | 24.38 | 24.39 |
| | | 1 | 14 | 24.34 | 24.40 | 24.38 |
| | | 8 | 0 | 23.31 | 23.22 | 23.19 |
| | | 8 | 3 | 23.33 | 23.26 | 23.33 |
| | | 8 | 7 | 23.28 | 23.20 | 23.27 |
| | | 15 | 0 | 23.29 | 23.27 | 23.33 |
| 3M | 16QAM | 1 | 0 | 23.38 | 23.40 | 23.46 |
| | | 1 | 7 | 23.47 | 23.47 | 23.42 |
| | | 1 | 14 | 23.39 | 23.45 | 23.40 |
| | | 8 | 0 | 22.38 | 22.24 | 22.24 |
| | | 8 | 3 | 22.35 | 22.36 | 22.34 |
| | | 8 | 7 | 22.30 | 22.21 | 22.31 |
| | | 15 | 0 | 22.29 | 22.36 | 22.37 |
| 3M | 64QAM | 1 | 0 | 22.28 | 22.35 | 22.41 |
| | | 1 | 7 | 22.39 | 22.44 | 22.36 |
| | | 1 | 14 | 22.31 | 22.38 | 22.38 |
| | | 8 | 0 | 21.28 | 21.21 | 21.18 |
| | | 8 | 3 | 21.27 | 21.30 | 21.34 |
| | | 8 | 7 | 21.23 | 21.18 | 21.27 |
| | | 15 | 0 | 21.22 | 21.28 | 21.36 |

*EIRP = Conducted + antenna gain (1.57dBi)

| LTE Band 66 | | | | | | |
|-------------|-----------|-----------------|-----------|--------|--------|--------------|
| BW | MCS Index | RB Size | RB Offset | Low | Mid | High |
| | | Channel | | 131979 | 132322 | 132665 |
| | | Frequency (MHz) | | 1710.7 | 1745 | 1779.3 |
| 1.4M | QPSK | 1 | 0 | 24.42 | 24.32 | 24.30 |
| | | 1 | 2 | 24.38 | 24.37 | 24.45 |
| | | 1 | 5 | 24.30 | 24.30 | 24.38 |
| | | 3 | 0 | 24.18 | 24.26 | 24.16 |
| | | 3 | 1 | 24.35 | 24.36 | 24.26 |
| | | 3 | 3 | 24.40 | 24.32 | 24.40 |
| | | 6 | 0 | 23.23 | 23.21 | 23.17 |
| 1.4M | 16QAM | 1 | 0 | 23.51 | 23.39 | 23.39 |
| | | 1 | 2 | 23.45 | 23.38 | 23.55 |
| | | 1 | 5 | 23.31 | 23.39 | 23.44 |
| | | 3 | 0 | 23.25 | 23.36 | 23.17 |
| | | 3 | 1 | 23.37 | 23.39 | 23.34 |
| | | 3 | 3 | 23.41 | 23.38 | 23.42 |
| | | 6 | 0 | 22.29 | 22.25 | 22.27 |
| 1.4M | 64QAM | 1 | 0 | 22.49 | 22.37 | 22.38 |
| | | 1 | 2 | 22.35 | 22.32 | 22.52 |
| | | 1 | 5 | 22.23 | 22.37 | 22.42 |
| | | 3 | 0 | 22.22 | 22.31 | 22.13 |
| | | 3 | 1 | 22.30 | 22.35 | 22.31 |
| | | 3 | 3 | 22.31 | 22.29 | 22.38 |
| | | 6 | 0 | 21.26 | 21.18 | 21.19 |

*EIRP = Conducted + antenna gain (1.57dBi)

| LTE Band 71 | | | | | | |
|-------------|-----------|-----------------|-----------|--------------|--------------|--------------|
| BW | MCS Index | RB Size | RB Offset | Low | Mid | High |
| | | Channel | | 133222 | 133297 | 133372 |
| | | Frequency (MHz) | | 673 | 680.5 | 688 |
| 20M | QPSK | 1 | 0 | 22.98 | 23.03 | 22.96 |
| | | 1 | 50 | 22.97 | 23.02 | 23.00 |
| | | 1 | 99 | 23.04 | 22.97 | 23.04 |
| | | 50 | 0 | 22.09 | 22.03 | 22.03 |
| | | 50 | 25 | 22.13 | 22.08 | 22.15 |
| | | 50 | 50 | 21.98 | 22.06 | 22.11 |
| | | 100 | 0 | 22.11 | 22.10 | 22.08 |
| 20M | 16QAM | 1 | 0 | 22.07 | 22.10 | 22.04 |
| | | 1 | 50 | 22.01 | 22.03 | 22.01 |
| | | 1 | 99 | 22.08 | 22.02 | 22.05 |
| | | 50 | 0 | 21.17 | 21.12 | 21.05 |
| | | 50 | 25 | 21.16 | 21.12 | 21.20 |
| | | 50 | 50 | 21.06 | 21.14 | 21.13 |
| | | 100 | 0 | 21.13 | 21.11 | 21.15 |
| 20M | 64QAM | 1 | 0 | 20.99 | 21.01 | 20.95 |
| | | 1 | 50 | 21.00 | 20.97 | 20.92 |
| | | 1 | 99 | 20.98 | 20.98 | 20.98 |
| | | 50 | 0 | 20.10 | 20.10 | 20.02 |
| | | 50 | 25 | 20.13 | 20.08 | 20.11 |
| | | 50 | 50 | 19.97 | 20.13 | 20.03 |
| | | 100 | 0 | 20.07 | 20.08 | 20.06 |

*ERP = Conducted + antenna gain (2.02dBi)-2.15

| LTE Band 71 | | | | | | |
|-------------|-----------|-----------------|-----------|--------|--------|--------------|
| BW | MCS Index | RB Size | RB Offset | Low | Mid | High |
| | | Channel | | 133197 | 133297 | 133397 |
| | | Frequency (MHz) | | 670.5 | 680.5 | 690.5 |
| 15M | QPSK | 1 | 0 | 23.11 | 23.16 | 23.19 |
| | | 1 | 37 | 23.00 | 23.03 | 22.98 |
| | | 1 | 74 | 23.02 | 23.07 | 23.02 |
| | | 36 | 0 | 22.09 | 22.03 | 22.11 |
| | | 36 | 19 | 22.05 | 22.08 | 22.16 |
| | | 36 | 39 | 22.10 | 22.06 | 22.02 |
| | | 75 | 0 | 22.09 | 22.08 | 21.98 |
| 15M | 16QAM | 1 | 0 | 22.21 | 22.16 | 22.28 |
| | | 1 | 37 | 22.07 | 22.05 | 22.04 |
| | | 1 | 74 | 22.05 | 22.16 | 22.03 |
| | | 36 | 0 | 21.17 | 21.06 | 21.15 |
| | | 36 | 19 | 21.12 | 21.18 | 21.16 |
| | | 36 | 39 | 21.13 | 21.15 | 21.03 |
| | | 75 | 0 | 21.11 | 21.12 | 21.02 |
| 15M | 64QAM | 1 | 0 | 21.15 | 21.08 | 21.18 |
| | | 1 | 37 | 21.03 | 21.04 | 20.95 |
| | | 1 | 74 | 21.03 | 21.16 | 20.99 |
| | | 36 | 0 | 20.16 | 19.99 | 20.06 |
| | | 36 | 19 | 20.06 | 20.14 | 20.08 |
| | | 36 | 39 | 20.09 | 20.09 | 19.97 |
| | | 75 | 0 | 20.11 | 20.05 | 19.92 |

*ERP = Conducted + antenna gain (2.02dBi)-2.15

| LTE Band 71 | | | | | | |
|-------------|-----------|-----------------|-----------|--------|--------|--------------|
| BW | MCS Index | RB Size | RB Offset | Low | Mid | High |
| | | Channel | | 133172 | 133297 | 133422 |
| | | Frequency (MHz) | | 668 | 680.5 | 693 |
| 10M | QPSK | 1 | 0 | 23.07 | 23.06 | 23.16 |
| | | 1 | 24 | 23.13 | 23.08 | 22.98 |
| | | 1 | 49 | 23.06 | 23.06 | 23.00 |
| | | 25 | 0 | 22.05 | 22.03 | 21.93 |
| | | 25 | 12 | 22.13 | 22.07 | 22.05 |
| | | 25 | 25 | 22.07 | 22.03 | 21.95 |
| | | 50 | 0 | 21.98 | 22.00 | 21.97 |
| 10M | 16QAM | 1 | 0 | 22.07 | 22.08 | 22.17 |
| | | 1 | 24 | 22.14 | 22.09 | 22.01 |
| | | 1 | 49 | 22.07 | 22.12 | 22.04 |
| | | 25 | 0 | 21.08 | 21.13 | 20.97 |
| | | 25 | 12 | 21.23 | 21.13 | 21.08 |
| | | 25 | 25 | 21.15 | 21.10 | 21.02 |
| | | 50 | 0 | 21.02 | 21.07 | 21.04 |
| 10M | 64QAM | 1 | 0 | 21.07 | 20.98 | 21.17 |
| | | 1 | 24 | 21.06 | 21.08 | 20.99 |
| | | 1 | 49 | 21.04 | 21.12 | 21.03 |
| | | 25 | 0 | 20.05 | 20.13 | 19.90 |
| | | 25 | 12 | 20.17 | 20.10 | 20.01 |
| | | 25 | 25 | 20.08 | 20.07 | 20.02 |
| | | 50 | 0 | 20.01 | 20.04 | 20.00 |

*ERP = Conducted + antenna gain (2.02dBi)-2.15

| LTE Band 71 | | | | | | |
|-------------|-----------|-----------------|-----------|--------------|--------------|--------|
| BW | MCS Index | RB Size | RB Offset | Low | Mid | High |
| | | Channel | | 133147 | 133297 | 133447 |
| | | Frequency (MHz) | | 665.5 | 680.5 | 695.5 |
| 5M | QPSK | 1 | 0 | 23.07 | 23.02 | 22.92 |
| | | 1 | 12 | 23.02 | 22.99 | 23.06 |
| | | 1 | 24 | 22.98 | 22.90 | 22.89 |
| | | 12 | 0 | 21.90 | 21.97 | 21.89 |
| | | 12 | 6 | 22.12 | 22.06 | 22.13 |
| | | 12 | 13 | 22.00 | 21.93 | 21.94 |
| | | 25 | 0 | 21.95 | 22.00 | 21.90 |
| 5M | 16QAM | 1 | 0 | 22.09 | 22.10 | 21.98 |
| | | 1 | 12 | 22.12 | 22.07 | 22.08 |
| | | 1 | 24 | 21.99 | 21.94 | 21.92 |
| | | 12 | 0 | 20.99 | 21.07 | 20.92 |
| | | 12 | 6 | 21.13 | 21.16 | 21.14 |
| | | 12 | 13 | 21.02 | 20.95 | 20.96 |
| | | 25 | 0 | 21.03 | 21.10 | 20.92 |
| 5M | 64QAM | 1 | 0 | 21.00 | 21.09 | 20.91 |
| | | 1 | 12 | 21.03 | 20.99 | 21.07 |
| | | 1 | 24 | 20.91 | 20.90 | 20.84 |
| | | 12 | 0 | 19.92 | 20.05 | 19.89 |
| | | 12 | 6 | 20.13 | 20.16 | 20.05 |
| | | 12 | 13 | 19.93 | 19.85 | 19.93 |
| | | 25 | 0 | 19.99 | 20.01 | 19.90 |

*ERP = Conducted + antenna gain (2.02dBi)-2.15

4.2 Modulation Characteristics Measurement

4.2.1 Limits of Modulation Characteristics

N/A

4.2.2 Test Procedure

Connect the EUT to Communication Simulator via the antenna connector, The frequency band is set as EUT supported Modulation and Channels, the EUT output is matched with 50 ohm load, the waveform quality and constellation of the EUT was tested.

4.2.3 Test Setup



4.2.4 Test Results

LTE Band 4

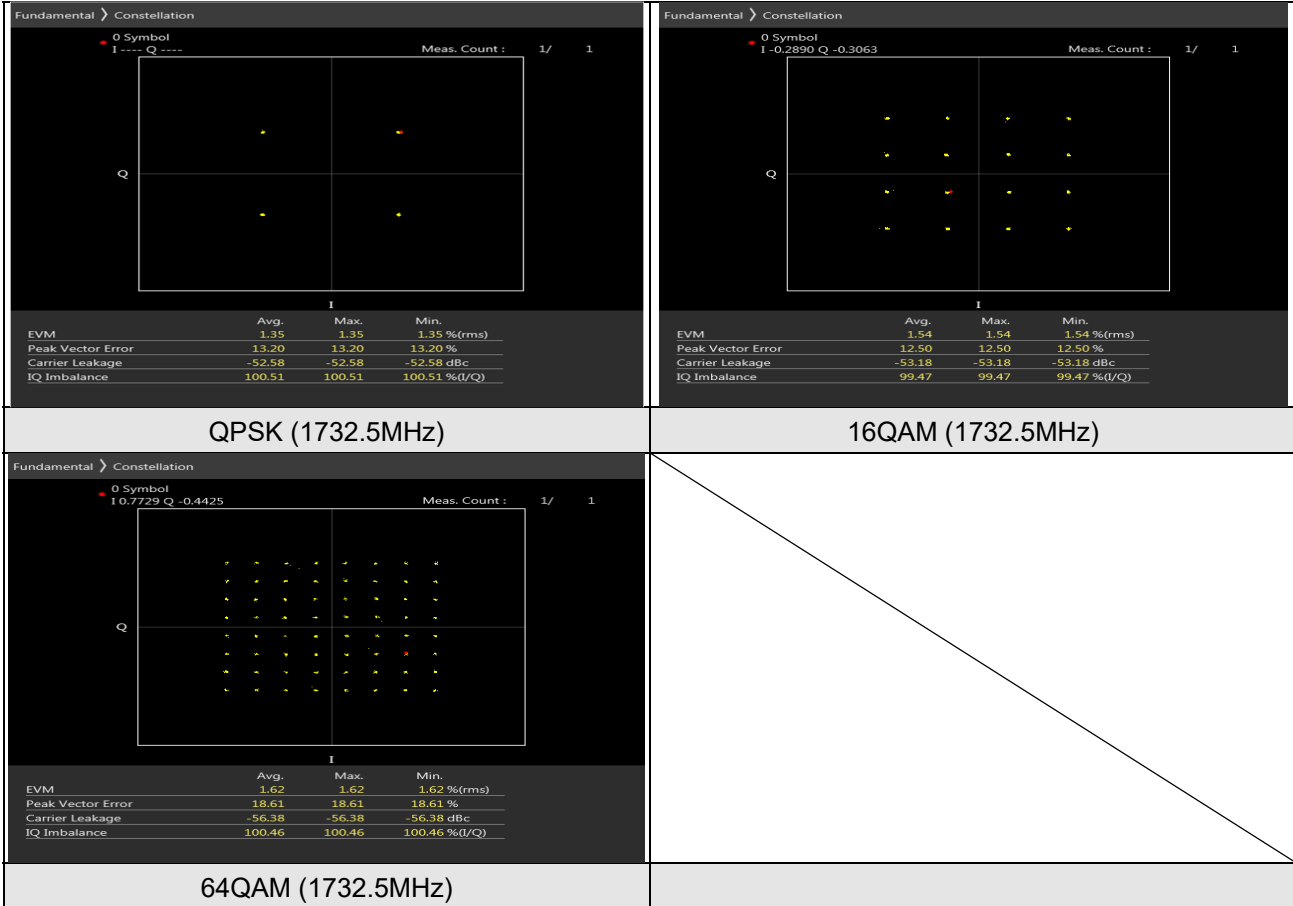

LTE Band 7

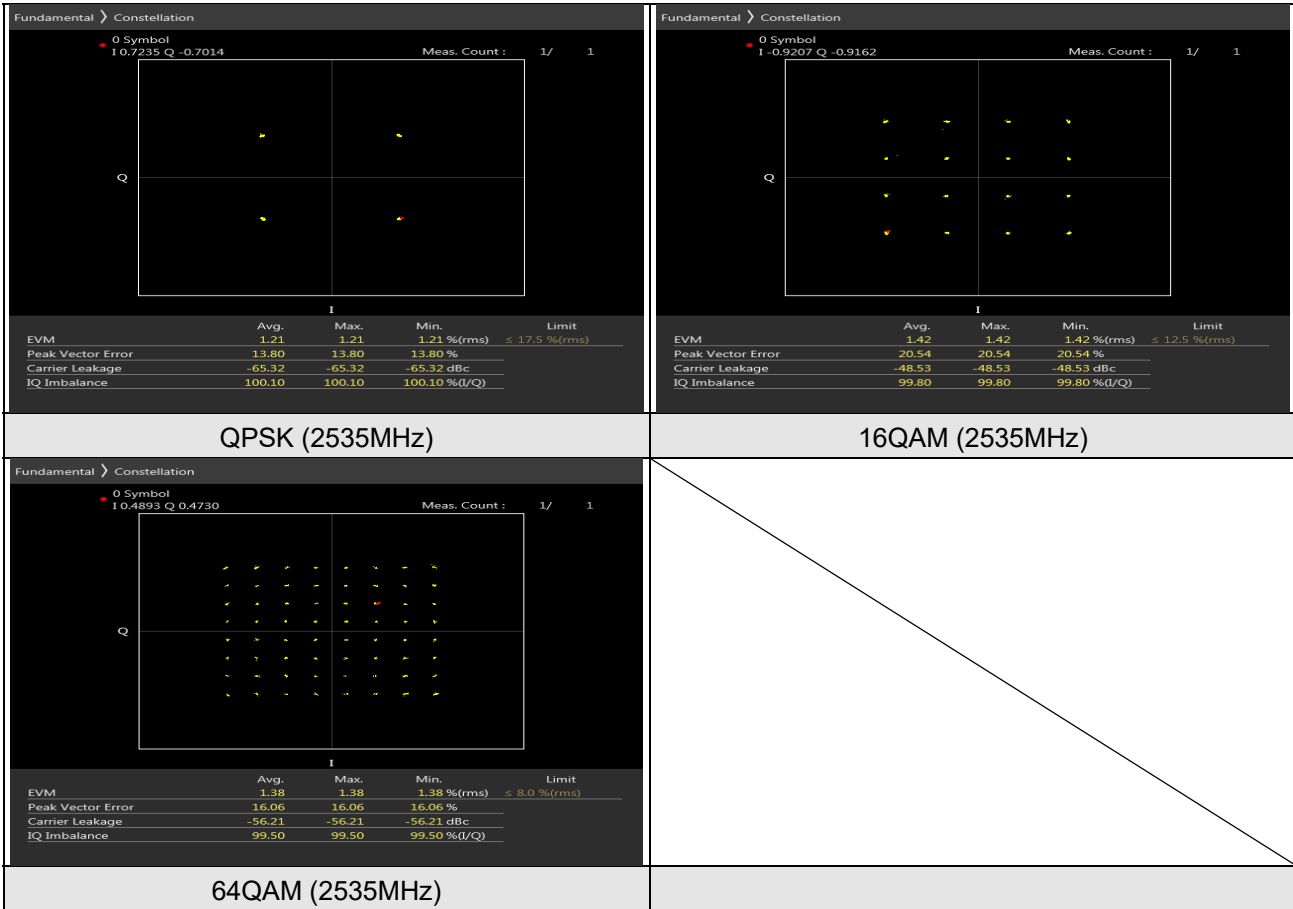

LTE Band 12



LTE Band 17

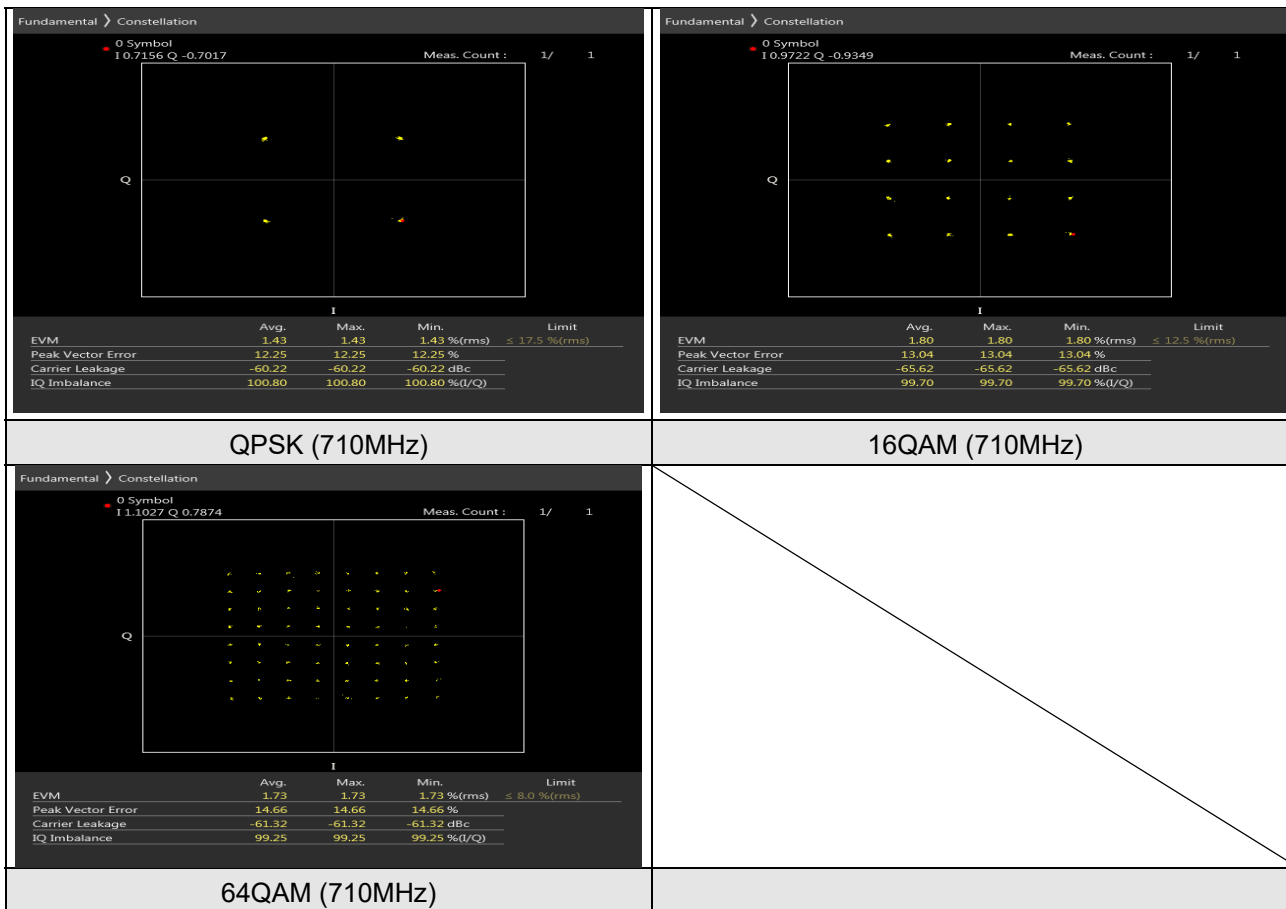

LTE Band 66

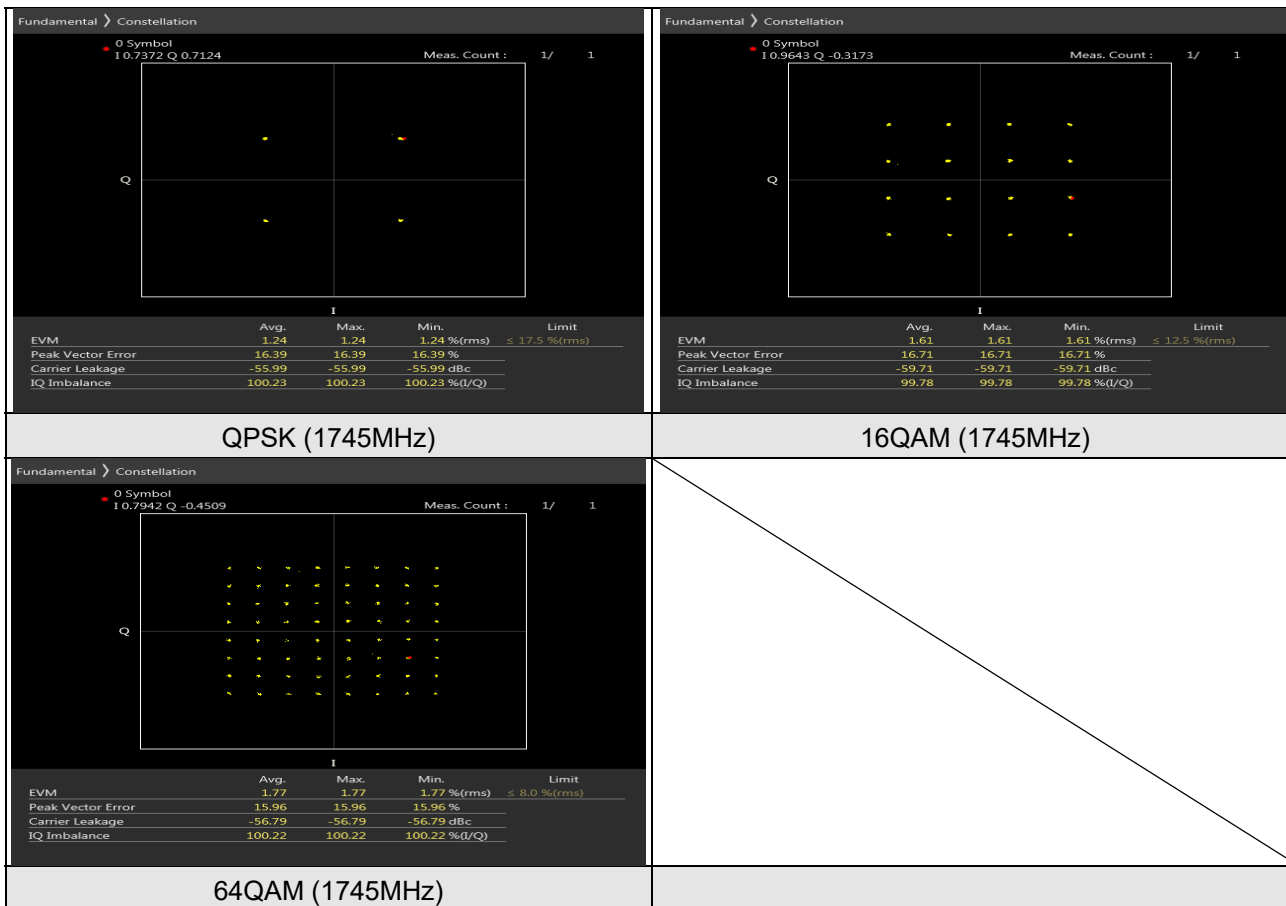

LTE Band 71

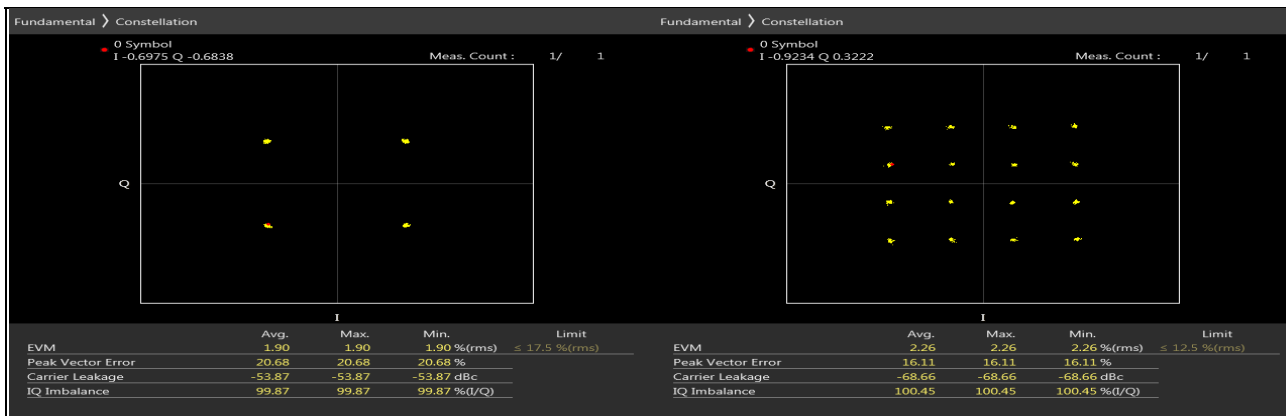

QPSK (680.5MHz)

16QAM (680.5MHz)

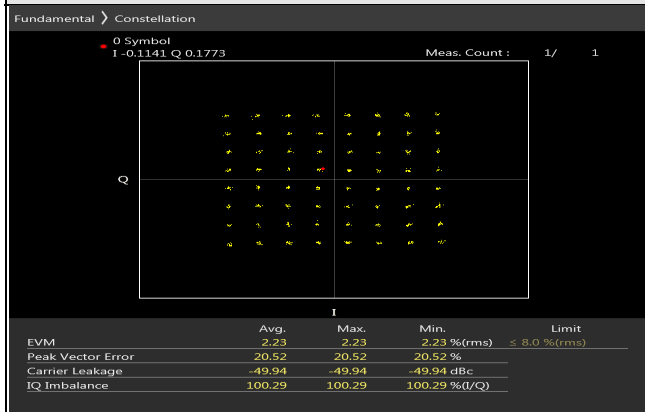

64QAM (680.5MHz)

4.3 Frequency Stability Measurement

4.3.1 Limits of Frequency Stability Measurement

The frequency stability shall be sufficient to ensure that the fundamental emissions stay within the authorized bands of operation.

4.3.2 Test Procedure

- a. Device is placed at the oven room. The oven room could control the temperatures and humidity. Power warm up is at least 15 min and power applied should perform before recording frequency error.
- b. EUT is connected the external power supply to control the DC input power. The test voltage range is from minimum to maximum working voltage. Each step shall be record the frequency error rate.
- c. The temperature range step is 10 degrees in this test items. All temperature levels shall be hold the ± 0.5 °C during the measurement testing. The each temperature step shall be at least 0.5 hours, consider the EUT could be test under the stability condition.

Note: The frequency error was recorded frequency error from the communication simulator.

4.3.3 Test Instruments

| Description & Manufacturer | Model No. | Serial No. | Cal. Date | Cal. Due |
|--|-----------|------------|---------------|---------------|
| Radio Communication Analyzer Anritsu | MT8821C | 6261806803 | Feb. 16, 2022 | Feb. 15, 2023 |
| Temperature & Humidity Chamber TERCHY | HRM-120RF | 931022 | Jan. 03, 2022 | Jan. 02, 2023 |
| Digital Multimeter Fluke | 87-III | 70360742 | Jun. 24, 2021 | Jun. 23, 2022 |
| DC Power Supply Topward | 6306A | 727263 | NA | NA |

Note: 1. The calibration interval of the above test instruments is 12 months and the calibrations are traceable to NML/ROC and NIST/USA.

4.3.4 Test Setup

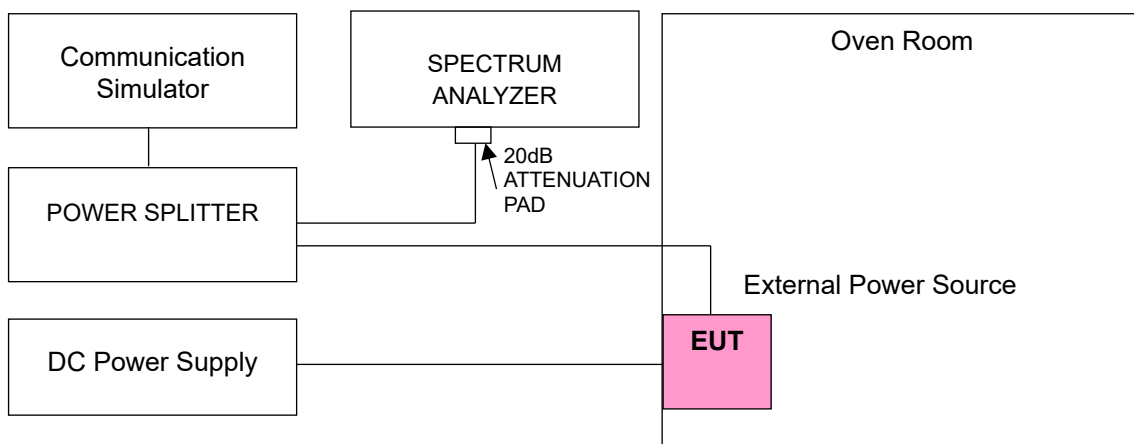

4.3.5 Test Results

Frequency Error vs. Voltage

| Voltage (Vdc) | LTE Band 4 | | | |
|---------------|---------------------------|-----------------------|-----------------|-----------------------|
| | Channel Bandwidth 1.4 MHz | | | |
| | Low Channel | | High Channel | |
| | Frequency (MHz) | Frequency Error (ppm) | Frequency (MHz) | Frequency Error (ppm) |
| 3.4 | 1710.700004 | 0.002 | 1754.300004 | 0.002 |
| 4.0 | 1710.700001 | 0.001 | 1754.300003 | 0.002 |
| 4.6 | 1710.700004 | 0.002 | 1754.299997 | -0.002 |

Note: The applicant defined the normal working voltage is from 3.4Vdc to 4.6Vdc.

Frequency Error vs. Temperature

| Temp. (°C) | LTE Band 4 | | | |
|------------|---------------------------|-----------------------|-----------------|-----------------------|
| | Channel Bandwidth 1.4 MHz | | | |
| | Low Channel | | High Channel | |
| | Frequency (MHz) | Frequency Error (ppm) | Frequency (MHz) | Frequency Error (ppm) |
| -40 | 1710.699996 | -0.002 | 1754.300003 | 0.002 |
| -30 | 1710.699998 | -0.001 | 1754.300002 | 0.001 |
| -20 | 1710.699999 | -0.001 | 1754.299999 | -0.001 |
| -10 | 1710.699997 | -0.002 | 1754.300004 | 0.002 |
| 0 | 1710.700002 | 0.001 | 1754.299995 | -0.003 |
| 10 | 1710.699999 | -0.001 | 1754.300004 | 0.002 |
| 20 | 1710.700003 | 0.002 | 1754.300003 | 0.002 |
| 30 | 1710.699996 | -0.002 | 1754.300002 | 0.001 |
| 40 | 1710.699998 | -0.001 | 1754.299997 | -0.002 |
| 50 | 1710.700005 | 0.003 | 1754.300002 | 0.001 |
| 60 | 1710.700003 | 0.002 | 1754.300001 | 0.001 |
| 70 | 1710.699997 | -0.002 | 1754.299995 | -0.003 |
| 80 | 1710.699998 | -0.001 | 1754.299998 | -0.001 |
| 85 | 1710.700003 | 0.002 | 1754.299996 | -0.002 |

Frequency Error vs. Voltage

| Voltage (Vdc) | LTE Band 4 | | | |
|---------------|-------------------------|-----------------------|-----------------|-----------------------|
| | Channel Bandwidth 3 MHz | | | |
| | Low Channel | | High Channel | |
| | Frequency (MHz) | Frequency Error (ppm) | Frequency (MHz) | Frequency Error (ppm) |
| 3.4 | 1711.499997 | -0.002 | 1753.499996 | -0.002 |
| 4.0 | 1711.499995 | -0.003 | 1753.500004 | 0.002 |
| 4.6 | 1711.500002 | 0.001 | 1753.500005 | 0.003 |

Note: The applicant defined the normal working voltage is from 3.4Vdc to 4.6Vdc.

Frequency Error vs. Temperature

| Temp. (°C) | LTE Band 4 | | | |
|------------|-------------------------|-----------------------|-----------------|-----------------------|
| | Channel Bandwidth 3 MHz | | | |
| | Low Channel | | High Channel | |
| | Frequency (MHz) | Frequency Error (ppm) | Frequency (MHz) | Frequency Error (ppm) |
| -40 | 1711.499998 | -0.001 | 1753.499995 | -0.003 |
| -30 | 1711.500001 | 0.001 | 1753.499999 | -0.001 |
| -20 | 1711.499999 | -0.001 | 1753.499995 | -0.003 |
| -10 | 1711.499997 | -0.002 | 1753.500003 | 0.002 |
| 0 | 1711.500001 | 0.001 | 1753.499997 | -0.002 |
| 10 | 1711.499996 | -0.002 | 1753.499999 | -0.001 |
| 20 | 1711.500001 | 0.001 | 1753.499997 | -0.002 |
| 30 | 1711.500001 | 0.001 | 1753.499999 | -0.001 |
| 40 | 1711.499998 | -0.001 | 1753.500005 | 0.003 |
| 50 | 1711.499999 | -0.001 | 1753.499997 | -0.002 |
| 60 | 1711.500002 | 0.001 | 1753.500002 | 0.001 |
| 70 | 1711.500003 | 0.002 | 1753.499996 | -0.002 |
| 80 | 1711.499998 | -0.001 | 1753.500001 | 0.001 |
| 85 | 1711.499998 | -0.001 | 1753.499999 | -0.001 |

Frequency Error vs. Voltage

| Voltage (Vdc) | LTE Band 4 | | | |
|---------------|------------------------|-----------------------|-----------------|-----------------------|
| | Channel Bandwidth 5MHz | | | |
| | Low Channel | | High Channel | |
| | Frequency (MHz) | Frequency Error (ppm) | Frequency (MHz) | Frequency Error (ppm) |
| 3.4 | 1712.499995 | -0.003 | 1752.500005 | 0.003 |
| 4.0 | 1712.499996 | -0.002 | 1752.499999 | -0.001 |
| 4.6 | 1712.499996 | -0.002 | 1752.499997 | -0.002 |

Note: The applicant defined the normal working voltage is from 3.4Vdc to 4.6Vdc.

Frequency Error vs. Temperature

| Temp. (°C) | LTE Band 4 | | | |
|------------|------------------------|-----------------------|-----------------|-----------------------|
| | Channel Bandwidth 5MHz | | | |
| | Low Channel | | High Channel | |
| | Frequency (MHz) | Frequency Error (ppm) | Frequency (MHz) | Frequency Error (ppm) |
| -40 | 1712.499996 | -0.002 | 1752.500003 | 0.002 |
| -30 | 1712.499995 | -0.003 | 1752.500003 | 0.002 |
| -20 | 1712.500003 | 0.002 | 1752.500005 | 0.003 |
| -10 | 1712.499995 | -0.003 | 1752.499999 | -0.001 |
| 0 | 1712.499999 | -0.001 | 1752.500005 | 0.003 |
| 10 | 1712.500005 | 0.003 | 1752.499999 | -0.001 |
| 20 | 1712.499997 | -0.002 | 1752.499997 | -0.002 |
| 30 | 1712.500005 | 0.003 | 1752.499998 | -0.001 |
| 40 | 1712.500005 | 0.003 | 1752.499999 | -0.001 |
| 50 | 1712.500004 | 0.002 | 1752.500002 | 0.001 |
| 60 | 1712.499995 | -0.003 | 1752.499995 | -0.003 |
| 70 | 1712.500003 | 0.002 | 1752.500004 | 0.002 |
| 80 | 1712.499999 | -0.001 | 1752.499999 | -0.001 |
| 85 | 1712.500001 | 0.001 | 1752.500002 | 0.001 |

Frequency Error vs. Voltage

| Voltage (Vdc) | LTE Band 4 | | | |
|---------------|-------------------------|-----------------------|-----------------|-----------------------|
| | Channel Bandwidth 10MHz | | | |
| | Low Channel | | High Channel | |
| | Frequency (MHz) | Frequency Error (ppm) | Frequency (MHz) | Frequency Error (ppm) |
| 3.4 | 1714.999998 | -0.001 | 1749.999998 | -0.001 |
| 4.0 | 1714.999995 | -0.003 | 1750.000004 | 0.002 |
| 4.6 | 1714.999996 | -0.002 | 1750.000004 | 0.002 |

Note: The applicant defined the normal working voltage is from 3.4Vdc to 4.6Vdc.

Frequency Error vs. Temperature

| Temp. (°C) | LTE Band 4 | | | |
|------------|-------------------------|-----------------------|-----------------|-----------------------|
| | Channel Bandwidth 10MHz | | | |
| | Low Channel | | High Channel | |
| | Frequency (MHz) | Frequency Error (ppm) | Frequency (MHz) | Frequency Error (ppm) |
| -40 | 1715.000005 | 0.003 | 1750.000002 | 0.001 |
| -30 | 1714.999999 | -0.001 | 1750.000001 | 0.001 |
| -20 | 1715.000005 | 0.003 | 1749.999996 | -0.002 |
| -10 | 1714.999998 | -0.001 | 1749.999997 | -0.002 |
| 0 | 1715.000005 | 0.003 | 1750.000003 | 0.002 |
| 10 | 1715.000001 | 0.001 | 1749.999999 | -0.001 |
| 20 | 1714.999997 | -0.002 | 1749.999996 | -0.002 |
| 30 | 1714.999996 | -0.002 | 1749.999999 | -0.001 |
| 40 | 1714.999995 | -0.003 | 1750.000005 | 0.003 |
| 50 | 1715.000001 | 0.001 | 1750.000002 | 0.001 |
| 60 | 1714.999995 | -0.003 | 1749.999998 | -0.001 |
| 70 | 1714.999996 | -0.002 | 1749.999996 | -0.002 |
| 80 | 1714.999999 | -0.001 | 1749.999996 | -0.002 |
| 85 | 1714.999998 | -0.001 | 1750.000002 | 0.001 |

Frequency Error vs. Voltage

| Voltage (Vdc) | LTE Band 4 | | | |
|---------------|-------------------------|-----------------------|-----------------|-----------------------|
| | Channel Bandwidth 15MHz | | | |
| | Low Channel | | High Channel | |
| | Frequency (MHz) | Frequency Error (ppm) | Frequency (MHz) | Frequency Error (ppm) |
| 3.4 | 1717.500001 | 0.001 | 1747.499995 | -0.003 |
| 4.0 | 1717.500002 | 0.001 | 1747.499997 | -0.002 |
| 4.6 | 1717.500004 | 0.002 | 1747.500001 | 0.001 |

Note: The applicant defined the normal working voltage is from 3.4Vdc to 4.6Vdc.

Frequency Error vs. Temperature

| Temp. (°C) | LTE Band 4 | | | |
|------------|-------------------------|-----------------------|-----------------|-----------------------|
| | Channel Bandwidth 15MHz | | | |
| | Low Channel | | High Channel | |
| | Frequency (MHz) | Frequency Error (ppm) | Frequency (MHz) | Frequency Error (ppm) |
| -40 | 1717.500002 | 0.001 | 1747.500005 | 0.003 |
| -30 | 1717.499995 | -0.003 | 1747.499997 | -0.002 |
| -20 | 1717.499997 | -0.002 | 1747.500005 | 0.003 |
| -10 | 1717.499999 | -0.001 | 1747.500005 | 0.003 |
| 0 | 1717.499999 | -0.001 | 1747.500002 | 0.001 |
| 10 | 1717.499996 | -0.002 | 1747.500003 | 0.002 |
| 20 | 1717.500004 | 0.002 | 1747.499996 | -0.002 |
| 30 | 1717.500002 | 0.001 | 1747.500003 | 0.002 |
| 40 | 1717.500005 | 0.003 | 1747.499997 | -0.002 |
| 50 | 1717.499999 | -0.001 | 1747.500003 | 0.002 |
| 60 | 1717.500005 | 0.003 | 1747.500002 | 0.001 |
| 70 | 1717.499995 | -0.003 | 1747.499998 | -0.001 |
| 80 | 1717.499995 | -0.003 | 1747.500005 | 0.003 |
| 85 | 1717.500002 | 0.001 | 1747.500005 | 0.003 |

Frequency Error vs. Voltage

| Voltage (Vdc) | LTE Band 4 | | | |
|---------------|-------------------------|-----------------------|-----------------|-----------------------|
| | Channel Bandwidth 20MHz | | | |
| | Low Channel | | High Channel | |
| | Frequency (MHz) | Frequency Error (ppm) | Frequency (MHz) | Frequency Error (ppm) |
| 3.4 | 1719.999995 | -0.003 | 1744.999998 | -0.001 |
| 4.0 | 1719.999997 | -0.002 | 1744.999998 | -0.001 |
| 4.6 | 1720.000005 | 0.003 | 1745.000002 | 0.001 |

Note: The applicant defined the normal working voltage is from 3.4Vdc to 4.6Vdc.

Frequency Error vs. Temperature

| Temp. (°C) | LTE Band 4 | | | |
|------------|-------------------------|-----------------------|-----------------|-----------------------|
| | Channel Bandwidth 20MHz | | | |
| | Low Channel | | High Channel | |
| | Frequency (MHz) | Frequency Error (ppm) | Frequency (MHz) | Frequency Error (ppm) |
| -40 | 1720.000004 | 0.002 | 1744.999998 | -0.001 |
| -30 | 1720.000004 | 0.002 | 1745.000004 | 0.002 |
| -20 | 1720.000004 | 0.002 | 1744.999999 | -0.001 |
| -10 | 1719.999998 | -0.001 | 1744.999996 | -0.002 |
| 0 | 1719.999995 | -0.003 | 1745.000005 | 0.003 |
| 10 | 1719.999999 | -0.001 | 1745.000002 | 0.001 |
| 20 | 1719.999998 | -0.001 | 1745.000003 | 0.002 |
| 30 | 1720.000005 | 0.003 | 1744.999996 | -0.002 |
| 40 | 1719.999995 | -0.003 | 1745.000001 | 0.001 |
| 50 | 1720.000001 | 0.001 | 1745.000003 | 0.002 |
| 60 | 1719.999995 | -0.003 | 1744.999998 | -0.001 |
| 70 | 1720.000005 | 0.003 | 1744.999997 | -0.002 |
| 80 | 1719.999995 | -0.003 | 1745.000003 | 0.002 |
| 85 | 1719.999998 | -0.001 | 1745.000002 | 0.001 |

Frequency Error vs. Voltage

| Voltage (Vdc) | LTE Band 7 | | | |
|---------------|------------------------|-----------------------|-----------------|-----------------------|
| | Channel Bandwidth 5MHz | | | |
| | Low Channel | | High Channel | |
| | Frequency (MHz) | Frequency Error (ppm) | Frequency (MHz) | Frequency Error (ppm) |
| 3.4 | 2502.499999 | 0.000 | 2567.500001 | 0.000 |
| 4.0 | 2502.499998 | -0.001 | 2567.499998 | -0.001 |
| 4.6 | 2502.499996 | -0.002 | 2567.499996 | -0.002 |

Note: The applicant defined the normal working voltage is from 3.4Vdc to 4.6Vdc.

Frequency Error vs. Temperature

| Temp. (°C) | LTE Band 7 | | | |
|------------|------------------------|-----------------------|-----------------|-----------------------|
| | Channel Bandwidth 5MHz | | | |
| | Low Channel | | High Channel | |
| | Frequency (MHz) | Frequency Error (ppm) | Frequency (MHz) | Frequency Error (ppm) |
| -40 | 2502.499995 | -0.002 | 2567.500003 | 0.001 |
| -30 | 2502.499996 | -0.002 | 2567.499998 | -0.001 |
| -20 | 2502.500001 | 0.000 | 2567.500001 | 0.000 |
| -10 | 2502.500002 | 0.001 | 2567.500004 | 0.002 |
| 0 | 2502.500001 | 0.000 | 2567.500005 | 0.002 |
| 10 | 2502.499998 | -0.001 | 2567.500002 | 0.001 |
| 20 | 2502.499997 | -0.001 | 2567.499996 | -0.002 |
| 30 | 2502.500003 | 0.001 | 2567.499998 | -0.001 |
| 40 | 2502.499995 | -0.002 | 2567.500005 | 0.002 |
| 50 | 2502.500001 | 0.000 | 2567.500003 | 0.001 |
| 60 | 2502.500001 | 0.000 | 2567.499998 | -0.001 |
| 70 | 2502.499999 | 0.000 | 2567.500001 | 0.000 |
| 80 | 2502.499998 | -0.001 | 2567.499996 | -0.002 |
| 85 | 2502.500001 | 0.000 | 2567.499995 | -0.002 |

Frequency Error vs. Voltage

| Voltage (Vdc) | LTE Band 7 | | | |
|---------------|-------------------------|-----------------------|-----------------|-----------------------|
| | Channel Bandwidth 10MHz | | | |
| | Low Channel | | High Channel | |
| | Frequency (MHz) | Frequency Error (ppm) | Frequency (MHz) | Frequency Error (ppm) |
| 3.4 | 2504.999998 | -0.001 | 2565.000001 | 0.000 |
| 4.0 | 2505.000004 | 0.002 | 2565.000003 | 0.001 |
| 4.6 | 2504.999997 | -0.001 | 2565.000003 | 0.001 |

Note: The applicant defined the normal working voltage is from 3.4Vdc to 4.6Vdc.

Frequency Error vs. Temperature

| Temp. (°C) | LTE Band 7 | | | |
|------------|-------------------------|-----------------------|-----------------|-----------------------|
| | Channel Bandwidth 10MHz | | | |
| | Low Channel | | High Channel | |
| | Frequency (MHz) | Frequency Error (ppm) | Frequency (MHz) | Frequency Error (ppm) |
| -40 | 2505.000003 | 0.001 | 2565.000004 | 0.002 |
| -30 | 2504.999998 | -0.001 | 2564.999996 | -0.002 |
| -20 | 2504.999999 | 0.000 | 2564.999997 | -0.001 |
| -10 | 2505.000001 | 0.000 | 2565.000005 | 0.002 |
| 0 | 2504.999996 | -0.002 | 2564.999995 | -0.002 |
| 10 | 2505.000003 | 0.001 | 2564.999996 | -0.002 |
| 20 | 2504.999997 | -0.001 | 2564.999995 | -0.002 |
| 30 | 2504.999999 | 0.000 | 2564.999999 | 0.000 |
| 40 | 2504.999997 | -0.001 | 2565.000005 | 0.002 |
| 50 | 2505.000004 | 0.002 | 2564.999996 | -0.002 |
| 60 | 2504.999999 | 0.000 | 2564.999995 | -0.002 |
| 70 | 2504.999998 | -0.001 | 2565.000005 | 0.002 |
| 80 | 2504.999995 | -0.002 | 2564.999999 | 0.000 |
| 85 | 2505.000005 | 0.002 | 2564.999998 | -0.001 |

Frequency Error vs. Voltage

| Voltage (Vdc) | LTE Band 7 | | | |
|---------------|-------------------------|-----------------------|-----------------|-----------------------|
| | Channel Bandwidth 15MHz | | | |
| | Low Channel | | High Channel | |
| | Frequency (MHz) | Frequency Error (ppm) | Frequency (MHz) | Frequency Error (ppm) |
| 3.4 | 2507.499996 | -0.002 | 2562.499999 | 0.000 |
| 4.0 | 2507.499997 | -0.001 | 2562.499997 | -0.001 |
| 4.6 | 2507.499995 | -0.002 | 2562.500003 | 0.001 |

Note: The applicant defined the normal working voltage is from 3.4Vdc to 4.6Vdc.

Frequency Error vs. Temperature

| Temp. (°C) | LTE Band 7 | | | |
|------------|-------------------------|-----------------------|-----------------|-----------------------|
| | Channel Bandwidth 15MHz | | | |
| | Low Channel | | High Channel | |
| | Frequency (MHz) | Frequency Error (ppm) | Frequency (MHz) | Frequency Error (ppm) |
| -40 | 2507.499997 | -0.001 | 2562.499996 | -0.002 |
| -30 | 2507.500004 | 0.002 | 2562.499997 | -0.001 |
| -20 | 2507.500001 | 0.000 | 2562.500004 | 0.002 |
| -10 | 2507.500004 | 0.002 | 2562.500003 | 0.001 |
| 0 | 2507.499995 | -0.002 | 2562.500002 | 0.001 |
| 10 | 2507.499996 | -0.002 | 2562.499995 | -0.002 |
| 20 | 2507.500003 | 0.001 | 2562.500005 | 0.002 |
| 30 | 2507.499999 | 0.000 | 2562.499999 | 0.000 |
| 40 | 2507.499999 | 0.000 | 2562.499995 | -0.002 |
| 50 | 2507.500005 | 0.002 | 2562.500001 | 0.000 |
| 60 | 2507.500001 | 0.000 | 2562.500005 | 0.002 |
| 70 | 2507.499996 | -0.002 | 2562.499997 | -0.001 |
| 80 | 2507.499995 | -0.002 | 2562.500002 | 0.001 |
| 85 | 2507.500004 | 0.002 | 2562.499996 | -0.002 |

Frequency Error vs. Voltage

| Voltage (Vdc) | LTE Band 7 | | | |
|---------------|-------------------------|-----------------------|-----------------|-----------------------|
| | Channel Bandwidth 20MHz | | | |
| | Low Channel | | High Channel | |
| | Frequency (MHz) | Frequency Error (ppm) | Frequency (MHz) | Frequency Error (ppm) |
| 3.4 | 2510.000003 | 0.001 | 2559.999996 | -0.002 |
| 4.0 | 2509.999998 | -0.001 | 2560.000001 | 0.000 |
| 4.6 | 2510.000005 | 0.002 | 2559.999997 | -0.001 |

Note: The applicant defined the normal working voltage is from 3.4Vdc to 4.6Vdc.

Frequency Error vs. Temperature

| Temp. (°C) | LTE Band 7 | | | |
|------------|-------------------------|-----------------------|-----------------|-----------------------|
| | Channel Bandwidth 20MHz | | | |
| | Low Channel | | High Channel | |
| | Frequency (MHz) | Frequency Error (ppm) | Frequency (MHz) | Frequency Error (ppm) |
| -40 | 2509.999997 | -0.001 | 2559.999998 | -0.001 |
| -30 | 2510.000004 | 0.002 | 2559.999995 | -0.002 |
| -20 | 2510.000004 | 0.002 | 2560.000005 | 0.002 |
| -10 | 2510.000001 | 0.000 | 2560.000001 | 0.000 |
| 0 | 2509.999997 | -0.001 | 2560.000005 | 0.002 |
| 10 | 2509.999999 | 0.000 | 2560.000003 | 0.001 |
| 20 | 2509.999997 | -0.001 | 2560.000001 | 0.000 |
| 30 | 2510.000005 | 0.002 | 2560.000004 | 0.002 |
| 40 | 2510.000005 | 0.002 | 2559.999997 | -0.001 |
| 50 | 2509.999998 | -0.001 | 2560.000003 | 0.001 |
| 60 | 2510.000005 | 0.002 | 2559.999995 | -0.002 |
| 70 | 2510.000001 | 0.000 | 2560.000004 | 0.002 |
| 80 | 2509.999997 | -0.001 | 2560.000003 | 0.001 |
| 85 | 2509.999995 | -0.002 | 2560.000004 | 0.002 |

Frequency Error vs. Voltage

| Voltage (Vdc) | LTE Band 12 | | | |
|---------------|---------------------------|-----------------------|-----------------|-----------------------|
| | Channel Bandwidth 1.4 MHz | | | |
| | Low Channel | | High Channel | |
| | Frequency (MHz) | Frequency Error (ppm) | Frequency (MHz) | Frequency Error (ppm) |
| 3.4 | 699.699997 | -0.004 | 715.299997 | -0.004 |
| 4.0 | 699.699995 | -0.007 | 715.300002 | 0.003 |
| 4.6 | 699.700004 | 0.006 | 715.299999 | -0.001 |

Note: The applicant defined the normal working voltage is from 3.4Vdc to 4.6Vdc.

Frequency Error vs. Temperature

| Temp. (°C) | LTE Band 12 | | | |
|------------|---------------------------|-----------------------|-----------------|-----------------------|
| | Channel Bandwidth 1.4 MHz | | | |
| | Low Channel | | High Channel | |
| | Frequency (MHz) | Frequency Error (ppm) | Frequency (MHz) | Frequency Error (ppm) |
| -40 | 699.700001 | 0.001 | 715.300002 | 0.003 |
| -30 | 699.700001 | 0.001 | 715.300004 | 0.006 |
| -20 | 699.699997 | -0.004 | 715.299999 | -0.001 |
| -10 | 699.699999 | -0.001 | 715.300004 | 0.006 |
| 0 | 699.699996 | -0.006 | 715.300005 | 0.007 |
| 10 | 699.699997 | -0.004 | 715.300004 | 0.006 |
| 20 | 699.699995 | -0.007 | 715.300005 | 0.007 |
| 30 | 699.700004 | 0.006 | 715.299998 | -0.003 |
| 40 | 699.700001 | 0.001 | 715.299997 | -0.004 |
| 50 | 699.700004 | 0.006 | 715.299997 | -0.004 |
| 60 | 699.699998 | -0.003 | 715.299997 | -0.004 |
| 70 | 699.699997 | -0.004 | 715.300001 | 0.001 |
| 80 | 699.699998 | -0.003 | 715.299996 | -0.006 |
| 85 | 699.699998 | -0.003 | 715.299997 | -0.004 |

Frequency Error vs. Voltage

| Voltage (Vdc) | LTE Band 12 | | | |
|---------------|-------------------------|-----------------------|-----------------|-----------------------|
| | Channel Bandwidth 3 MHz | | | |
| | Low Channel | | High Channel | |
| | Frequency (MHz) | Frequency Error (ppm) | Frequency (MHz) | Frequency Error (ppm) |
| 3.4 | 700.499996 | -0.006 | 714.500004 | 0.006 |
| 4.0 | 700.499997 | -0.004 | 714.499996 | -0.006 |
| 4.6 | 700.499998 | -0.003 | 714.500001 | 0.001 |

Note: The applicant defined the normal working voltage is from 3.4Vdc to 4.6Vdc.

Frequency Error vs. Temperature

| Temp. (°C) | LTE Band 12 | | | |
|------------|-------------------------|-----------------------|-----------------|-----------------------|
| | Channel Bandwidth 3 MHz | | | |
| | Low Channel | | High Channel | |
| | Frequency (MHz) | Frequency Error (ppm) | Frequency (MHz) | Frequency Error (ppm) |
| -40 | 700.500004 | 0.006 | 714.499996 | -0.006 |
| -30 | 700.500004 | 0.006 | 714.499998 | -0.003 |
| -20 | 700.499996 | -0.006 | 714.500002 | 0.003 |
| -10 | 700.499995 | -0.007 | 714.499998 | -0.003 |
| 0 | 700.500005 | 0.007 | 714.500003 | 0.004 |
| 10 | 700.500004 | 0.006 | 714.499999 | -0.001 |
| 20 | 700.500002 | 0.003 | 714.500003 | 0.004 |
| 30 | 700.499998 | -0.003 | 714.500002 | 0.003 |
| 40 | 700.500002 | 0.003 | 714.500004 | 0.006 |
| 50 | 700.500002 | 0.003 | 714.500004 | 0.006 |
| 60 | 700.500004 | 0.006 | 714.500001 | 0.001 |
| 70 | 700.499998 | -0.003 | 714.500002 | 0.003 |
| 80 | 700.499998 | -0.003 | 714.499996 | -0.006 |
| 85 | 700.500005 | 0.007 | 714.500003 | 0.004 |

Frequency Error vs. Voltage

| Voltage (Vdc) | LTE Band 12 | | | |
|---------------|------------------------|-----------------------|-----------------|-----------------------|
| | Channel Bandwidth 5MHz | | | |
| | Low Channel | | High Channel | |
| | Frequency (MHz) | Frequency Error (ppm) | Frequency (MHz) | Frequency Error (ppm) |
| 3.4 | 701.499996 | -0.006 | 713.499998 | -0.003 |
| 4.0 | 701.500003 | 0.004 | 713.500003 | 0.004 |
| 4.6 | 701.499998 | -0.003 | 713.500004 | 0.006 |

Note: The applicant defined the normal working voltage is from 3.4Vdc to 4.6Vdc.

Frequency Error vs. Temperature

| Temp. (°C) | LTE Band 12 | | | |
|------------|------------------------|-----------------------|-----------------|-----------------------|
| | Channel Bandwidth 5MHz | | | |
| | Low Channel | | High Channel | |
| | Frequency (MHz) | Frequency Error (ppm) | Frequency (MHz) | Frequency Error (ppm) |
| -40 | 701.499998 | -0.003 | 713.500004 | 0.006 |
| -30 | 701.500003 | 0.004 | 713.499997 | -0.004 |
| -20 | 701.499997 | -0.004 | 713.500003 | 0.004 |
| -10 | 701.499999 | -0.001 | 713.500004 | 0.006 |
| 0 | 701.499996 | -0.006 | 713.500001 | 0.001 |
| 10 | 701.500001 | 0.001 | 713.500004 | 0.006 |
| 20 | 701.499999 | -0.001 | 713.499998 | -0.003 |
| 30 | 701.500005 | 0.007 | 713.499998 | -0.003 |
| 40 | 701.500005 | 0.007 | 713.499995 | -0.007 |
| 50 | 701.500003 | 0.004 | 713.500001 | 0.001 |
| 60 | 701.500001 | 0.001 | 713.500002 | 0.003 |
| 70 | 701.499999 | -0.001 | 713.499995 | -0.007 |
| 80 | 701.499996 | -0.006 | 713.499999 | -0.001 |
| 85 | 701.500004 | 0.006 | 713.500002 | 0.003 |

Frequency Error vs. Voltage

| Voltage (Vdc) | LTE Band 12 | | | |
|---------------|-------------------------|-----------------------|-----------------|-----------------------|
| | Channel Bandwidth 10MHz | | | |
| | Low Channel | | High Channel | |
| | Frequency (MHz) | Frequency Error (ppm) | Frequency (MHz) | Frequency Error (ppm) |
| 3.4 | 703.999999 | -0.001 | 710.999999 | -0.001 |
| 4.0 | 704.000001 | 0.001 | 711.000001 | 0.001 |
| 4.6 | 704.000004 | 0.006 | 710.999999 | -0.001 |

Note: The applicant defined the normal working voltage is from 3.4Vdc to 4.6Vdc.

Frequency Error vs. Temperature

| Temp. (°C) | LTE Band 12 | | | |
|------------|-------------------------|-----------------------|-----------------|-----------------------|
| | Channel Bandwidth 10MHz | | | |
| | Low Channel | | High Channel | |
| | Frequency (MHz) | Frequency Error (ppm) | Frequency (MHz) | Frequency Error (ppm) |
| -40 | 703.999998 | -0.003 | 711.000001 | 0.001 |
| -30 | 704.000002 | 0.003 | 711.000005 | 0.007 |
| -20 | 704.000004 | 0.006 | 711.000004 | 0.006 |
| -10 | 703.999995 | -0.007 | 710.999997 | -0.004 |
| 0 | 703.999998 | -0.003 | 711.000003 | 0.004 |
| 10 | 704.000003 | 0.004 | 710.999996 | -0.006 |
| 20 | 703.999995 | -0.007 | 710.999998 | -0.003 |
| 30 | 704.000003 | 0.004 | 710.999998 | -0.003 |
| 40 | 703.999995 | -0.007 | 710.999996 | -0.006 |
| 50 | 703.999998 | -0.003 | 711.000005 | 0.007 |
| 60 | 704.000005 | 0.007 | 710.999997 | -0.004 |
| 70 | 704.000002 | 0.003 | 710.999999 | -0.001 |
| 80 | 703.999998 | -0.003 | 711.000001 | 0.001 |
| 85 | 704.000002 | 0.003 | 710.999998 | -0.003 |

Frequency Error vs. Voltage

| Voltage (Vdc) | LTE Band 17 | | | |
|---------------|------------------------|-----------------------|-----------------|-----------------------|
| | Channel Bandwidth 5MHz | | | |
| | Low Channel | | High Channel | |
| | Frequency (MHz) | Frequency Error (ppm) | Frequency (MHz) | Frequency Error (ppm) |
| 3.4 | 706.499996 | -0.006 | 713.500002 | 0.003 |
| 4.0 | 706.500002 | 0.003 | 713.500003 | 0.004 |
| 4.6 | 706.500005 | 0.007 | 713.500004 | 0.006 |

Note: The applicant defined the normal working voltage is from 3.4Vdc to 4.6Vdc.

Frequency Error vs. Temperature

| Temp. (°C) | LTE Band 17 | | | |
|------------|------------------------|-----------------------|-----------------|-----------------------|
| | Channel Bandwidth 5MHz | | | |
| | Low Channel | | High Channel | |
| | Frequency (MHz) | Frequency Error (ppm) | Frequency (MHz) | Frequency Error (ppm) |
| -40 | 706.500002 | 0.003 | 713.500003 | 0.004 |
| -30 | 706.500004 | 0.006 | 713.499996 | -0.006 |
| -20 | 706.500002 | 0.003 | 713.500002 | 0.003 |
| -10 | 706.500002 | 0.003 | 713.500005 | 0.007 |
| 0 | 706.500003 | 0.004 | 713.499999 | -0.001 |
| 10 | 706.499996 | -0.006 | 713.499997 | -0.004 |
| 20 | 706.500005 | 0.007 | 713.500003 | 0.004 |
| 30 | 706.499996 | -0.006 | 713.500002 | 0.003 |
| 40 | 706.499998 | -0.003 | 713.500005 | 0.007 |
| 50 | 706.500005 | 0.007 | 713.500001 | 0.001 |
| 60 | 706.499997 | -0.004 | 713.499995 | -0.007 |
| 70 | 706.499998 | -0.003 | 713.500002 | 0.003 |
| 80 | 706.500002 | 0.003 | 713.499996 | -0.006 |
| 85 | 706.500002 | 0.003 | 713.499999 | -0.001 |

Frequency Error vs. Voltage

| Voltage (Vdc) | LTE Band 17 | | | |
|---------------|-------------------------|-----------------------|-----------------|-----------------------|
| | Channel Bandwidth 10MHz | | | |
| | Low Channel | | High Channel | |
| | Frequency (MHz) | Frequency Error (ppm) | Frequency (MHz) | Frequency Error (ppm) |
| 3.4 | 708.999996 | -0.006 | 710.999999 | -0.001 |
| 4.0 | 708.999999 | -0.001 | 710.999995 | -0.007 |
| 4.6 | 708.999995 | -0.007 | 711.000005 | 0.007 |

Note: The applicant defined the normal working voltage is from 3.4Vdc to 4.6Vdc.

Frequency Error vs. Temperature

| Temp. (°C) | LTE Band 17 | | | |
|------------|-------------------------|-----------------------|-----------------|-----------------------|
| | Channel Bandwidth 10MHz | | | |
| | Low Channel | | High Channel | |
| | Frequency (MHz) | Frequency Error (ppm) | Frequency (MHz) | Frequency Error (ppm) |
| -40 | 709.000001 | 0.001 | 711.000002 | 0.003 |
| -30 | 708.999999 | -0.001 | 710.999996 | -0.006 |
| -20 | 708.999996 | -0.006 | 710.999999 | -0.001 |
| -10 | 709.000003 | 0.004 | 710.999996 | -0.006 |
| 0 | 708.999995 | -0.007 | 710.999997 | -0.004 |
| 10 | 708.999999 | -0.001 | 710.999998 | -0.003 |
| 20 | 708.999996 | -0.006 | 710.999995 | -0.007 |
| 30 | 709.000001 | 0.001 | 711.000005 | 0.007 |
| 40 | 709.000002 | 0.003 | 710.999995 | -0.007 |
| 50 | 708.999998 | -0.003 | 710.999998 | -0.003 |
| 60 | 708.999997 | -0.004 | 711.000005 | 0.007 |
| 70 | 708.999998 | -0.003 | 711.000001 | 0.001 |
| 80 | 709.000001 | 0.001 | 710.999995 | -0.007 |
| 85 | 708.999998 | -0.003 | 711.000004 | 0.006 |

Frequency Error vs. Voltage

| Voltage (Vdc) | LTE Band 66 | | | |
|---------------|---------------------------|-----------------------|-----------------|-----------------------|
| | Channel Bandwidth 1.4 MHz | | | |
| | Low Channel | | High Channel | |
| | Frequency (MHz) | Frequency Error (ppm) | Frequency (MHz) | Frequency Error (ppm) |
| 3.4 | 1710.699997 | -0.002 | 1779.300004 | 0.002 |
| 4.0 | 1710.700001 | 0.001 | 1779.300002 | 0.001 |
| 4.6 | 1710.699996 | -0.002 | 1779.300005 | 0.003 |

Note: The applicant defined the normal working voltage is from 3.4Vdc to 4.6Vdc.

Frequency Error vs. Temperature

| Temp. (°C) | LTE Band 66 | | | |
|------------|---------------------------|-----------------------|-----------------|-----------------------|
| | Channel Bandwidth 1.4 MHz | | | |
| | Low Channel | | High Channel | |
| | Frequency (MHz) | Frequency Error (ppm) | Frequency (MHz) | Frequency Error (ppm) |
| -40 | 1710.699997 | -0.002 | 1779.300005 | 0.003 |
| -30 | 1710.699996 | -0.002 | 1779.300003 | 0.002 |
| -20 | 1710.699997 | -0.002 | 1779.299995 | -0.003 |
| -10 | 1710.700002 | 0.001 | 1779.299997 | -0.002 |
| 0 | 1710.699997 | -0.002 | 1779.300001 | 0.001 |
| 10 | 1710.700005 | 0.003 | 1779.300004 | 0.002 |
| 20 | 1710.699997 | -0.002 | 1779.299998 | -0.001 |
| 30 | 1710.699995 | -0.003 | 1779.299996 | -0.002 |
| 40 | 1710.700005 | 0.003 | 1779.300001 | 0.001 |
| 50 | 1710.699999 | -0.001 | 1779.299999 | -0.001 |
| 60 | 1710.699995 | -0.003 | 1779.299998 | -0.001 |
| 70 | 1710.699999 | -0.001 | 1779.299998 | -0.001 |
| 80 | 1710.700005 | 0.003 | 1779.300005 | 0.003 |
| 85 | 1710.700004 | 0.002 | 1779.300003 | 0.002 |

Frequency Error vs. Voltage

| Voltage (Vdc) | LTE Band 66 | | | |
|---------------|-------------------------|-----------------------|-----------------|-----------------------|
| | Channel Bandwidth 3 MHz | | | |
| | Low Channel | | High Channel | |
| | Frequency (MHz) | Frequency Error (ppm) | Frequency (MHz) | Frequency Error (ppm) |
| 3.4 | 1711.499997 | -0.002 | 1778.500005 | 0.003 |
| 4.0 | 1711.500001 | 0.001 | 1778.500003 | 0.002 |
| 4.6 | 1711.499997 | -0.002 | 1778.500001 | 0.001 |

Note: The applicant defined the normal working voltage is from 3.4Vdc to 4.6Vdc.

Frequency Error vs. Temperature

| Temp. (°C) | LTE Band 66 | | | |
|------------|-------------------------|-----------------------|-----------------|-----------------------|
| | Channel Bandwidth 3 MHz | | | |
| | Low Channel | | High Channel | |
| | Frequency (MHz) | Frequency Error (ppm) | Frequency (MHz) | Frequency Error (ppm) |
| -40 | 1711.499999 | -0.001 | 1778.499996 | -0.002 |
| -30 | 1711.500005 | 0.003 | 1778.500001 | 0.001 |
| -20 | 1711.500004 | 0.002 | 1778.500003 | 0.002 |
| -10 | 1711.500002 | 0.001 | 1778.500005 | 0.003 |
| 0 | 1711.500005 | 0.003 | 1778.499998 | -0.001 |
| 10 | 1711.500003 | 0.002 | 1778.499999 | -0.001 |
| 20 | 1711.500001 | 0.001 | 1778.499995 | -0.003 |
| 30 | 1711.500001 | 0.001 | 1778.499998 | -0.001 |
| 40 | 1711.499995 | -0.003 | 1778.500005 | 0.003 |
| 50 | 1711.499996 | -0.002 | 1778.500001 | 0.001 |
| 60 | 1711.499999 | -0.001 | 1778.500001 | 0.001 |
| 70 | 1711.499997 | -0.002 | 1778.500005 | 0.003 |
| 80 | 1711.500002 | 0.001 | 1778.500003 | 0.002 |
| 85 | 1711.500002 | 0.001 | 1778.500002 | 0.001 |

Frequency Error vs. Voltage

| Voltage (Vdc) | LTE Band 66 | | | |
|---------------|------------------------|-----------------------|-----------------|-----------------------|
| | Channel Bandwidth 5MHz | | | |
| | Low Channel | | High Channel | |
| | Frequency (MHz) | Frequency Error (ppm) | Frequency (MHz) | Frequency Error (ppm) |
| 3.4 | 1712.500001 | 0.001 | 1777.499998 | -0.001 |
| 4.0 | 1712.499999 | -0.001 | 1777.500003 | 0.002 |
| 4.6 | 1712.499999 | -0.001 | 1777.500003 | 0.002 |

Note: The applicant defined the normal working voltage is from 3.4Vdc to 4.6Vdc.

Frequency Error vs. Temperature

| Temp. (°C) | LTE Band 66 | | | |
|------------|------------------------|-----------------------|-----------------|-----------------------|
| | Channel Bandwidth 5MHz | | | |
| | Low Channel | | High Channel | |
| | Frequency (MHz) | Frequency Error (ppm) | Frequency (MHz) | Frequency Error (ppm) |
| -40 | 1712.499995 | -0.003 | 1777.499995 | -0.003 |
| -30 | 1712.500001 | 0.001 | 1777.500002 | 0.001 |
| -20 | 1712.499996 | -0.002 | 1777.499999 | -0.001 |
| -10 | 1712.500002 | 0.001 | 1777.500001 | 0.001 |
| 0 | 1712.500001 | 0.001 | 1777.499998 | -0.001 |
| 10 | 1712.500001 | 0.001 | 1777.500002 | 0.001 |
| 20 | 1712.500005 | 0.003 | 1777.499997 | -0.002 |
| 30 | 1712.500001 | 0.001 | 1777.499999 | -0.001 |
| 40 | 1712.499997 | -0.002 | 1777.500004 | 0.002 |
| 50 | 1712.499995 | -0.003 | 1777.500003 | 0.002 |
| 60 | 1712.500001 | 0.001 | 1777.499998 | -0.001 |
| 70 | 1712.499995 | -0.003 | 1777.499998 | -0.001 |
| 80 | 1712.499996 | -0.002 | 1777.499998 | -0.001 |
| 85 | 1712.500004 | 0.002 | 1777.499999 | -0.001 |

Frequency Error vs. Voltage

| Voltage (Vdc) | LTE Band 66 | | | |
|---------------|-------------------------|-----------------------|-----------------|-----------------------|
| | Channel Bandwidth 10MHz | | | |
| | Low Channel | | High Channel | |
| | Frequency (MHz) | Frequency Error (ppm) | Frequency (MHz) | Frequency Error (ppm) |
| 3.4 | 1715.000003 | 0.002 | 1774.999999 | -0.001 |
| 4.0 | 1715.000004 | 0.002 | 1775.000005 | 0.003 |
| 4.6 | 1715.000004 | 0.002 | 1775.000004 | 0.002 |

Note: The applicant defined the normal working voltage is from 3.4Vdc to 4.6Vdc.

Frequency Error vs. Temperature

| Temp. (°C) | LTE Band 66 | | | |
|------------|-------------------------|-----------------------|-----------------|-----------------------|
| | Channel Bandwidth 10MHz | | | |
| | Low Channel | | High Channel | |
| | Frequency (MHz) | Frequency Error (ppm) | Frequency (MHz) | Frequency Error (ppm) |
| -40 | 1714.999996 | -0.002 | 1774.999997 | -0.002 |
| -30 | 1715.000001 | 0.001 | 1774.999999 | -0.001 |
| -20 | 1714.999999 | -0.001 | 1775.000001 | 0.001 |
| -10 | 1715.000005 | 0.003 | 1775.000003 | 0.002 |
| 0 | 1714.999999 | -0.001 | 1774.999996 | -0.002 |
| 10 | 1714.999999 | -0.001 | 1774.999999 | -0.001 |
| 20 | 1715.000004 | 0.002 | 1775.000002 | 0.001 |
| 30 | 1715.000005 | 0.003 | 1775.000002 | 0.001 |
| 40 | 1714.999996 | -0.002 | 1775.000005 | 0.003 |
| 50 | 1714.999998 | -0.001 | 1775.000001 | 0.001 |
| 60 | 1715.000005 | 0.003 | 1775.000002 | 0.001 |
| 70 | 1715.000004 | 0.002 | 1774.999995 | -0.003 |
| 80 | 1715.000003 | 0.002 | 1775.000005 | 0.003 |
| 85 | 1715.000005 | 0.003 | 1774.999997 | -0.002 |

Frequency Error vs. Voltage

| Voltage (Vdc) | LTE Band 66 | | | |
|---------------|-------------------------|-----------------------|-----------------|-----------------------|
| | Channel Bandwidth 15MHz | | | |
| | Low Channel | | High Channel | |
| | Frequency (MHz) | Frequency Error (ppm) | Frequency (MHz) | Frequency Error (ppm) |
| 3.4 | 1717.500003 | 0.002 | 1772.499996 | -0.002 |
| 4.0 | 1717.499997 | -0.002 | 1772.499997 | -0.002 |
| 4.6 | 1717.499998 | -0.001 | 1772.500001 | 0.001 |

Note: The applicant defined the normal working voltage is from 3.4Vdc to 4.6Vdc.

Frequency Error vs. Temperature

| Temp. (°C) | LTE Band 66 | | | |
|------------|-------------------------|-----------------------|-----------------|-----------------------|
| | Channel Bandwidth 15MHz | | | |
| | Low Channel | | High Channel | |
| | Frequency (MHz) | Frequency Error (ppm) | Frequency (MHz) | Frequency Error (ppm) |
| -40 | 1717.499999 | -0.001 | 1772.499995 | -0.003 |
| -30 | 1717.499996 | -0.002 | 1772.499996 | -0.002 |
| -20 | 1717.500002 | 0.001 | 1772.499999 | -0.001 |
| -10 | 1717.499996 | -0.002 | 1772.499995 | -0.003 |
| 0 | 1717.499997 | -0.002 | 1772.500002 | 0.001 |
| 10 | 1717.499996 | -0.002 | 1772.499995 | -0.003 |
| 20 | 1717.499996 | -0.002 | 1772.499999 | -0.001 |
| 30 | 1717.499995 | -0.003 | 1772.500001 | 0.001 |
| 40 | 1717.500001 | 0.001 | 1772.500004 | 0.002 |
| 50 | 1717.499997 | -0.002 | 1772.499997 | -0.002 |
| 60 | 1717.500002 | 0.001 | 1772.499999 | -0.001 |
| 70 | 1717.499997 | -0.002 | 1772.499999 | -0.001 |
| 80 | 1717.499999 | -0.001 | 1772.499996 | -0.002 |
| 85 | 1717.499995 | -0.003 | 1772.500005 | 0.003 |

Frequency Error vs. Voltage

| Voltage (Vdc) | LTE Band 66 | | | |
|---------------|-------------------------|-----------------------|-----------------|-----------------------|
| | Channel Bandwidth 20MHz | | | |
| | Low Channel | | High Channel | |
| | Frequency (MHz) | Frequency Error (ppm) | Frequency (MHz) | Frequency Error (ppm) |
| 3.4 | 1719.999995 | -0.003 | 1770.000001 | 0.001 |
| 4.0 | 1720.000003 | 0.002 | 1770.000002 | 0.001 |
| 4.6 | 1719.999995 | -0.003 | 1770.000001 | 0.001 |

Note: The applicant defined the normal working voltage is from 3.4Vdc to 4.6Vdc.

Frequency Error vs. Temperature

| Temp. (°C) | LTE Band 66 | | | |
|------------|-------------------------|-----------------------|-----------------|-----------------------|
| | Channel Bandwidth 20MHz | | | |
| | Low Channel | | High Channel | |
| | Frequency (MHz) | Frequency Error (ppm) | Frequency (MHz) | Frequency Error (ppm) |
| -40 | 1719.999997 | -0.002 | 1769.999997 | -0.002 |
| -30 | 1720.000003 | 0.002 | 1769.999998 | -0.001 |
| -20 | 1719.999997 | -0.002 | 1769.999997 | -0.002 |
| -10 | 1720.000005 | 0.003 | 1769.999998 | -0.001 |
| 0 | 1719.999995 | -0.003 | 1770.000004 | 0.002 |
| 10 | 1720.000003 | 0.002 | 1770.000005 | 0.003 |
| 20 | 1719.999999 | -0.001 | 1769.999996 | -0.002 |
| 30 | 1719.999999 | -0.001 | 1769.999998 | -0.001 |
| 40 | 1720.000004 | 0.002 | 1769.999999 | -0.001 |
| 50 | 1720.000005 | 0.003 | 1769.999997 | -0.002 |
| 60 | 1720.000003 | 0.002 | 1770.000003 | 0.002 |
| 70 | 1719.999998 | -0.001 | 1769.999996 | -0.002 |
| 80 | 1720.000002 | 0.001 | 1769.999996 | -0.002 |
| 85 | 1719.999997 | -0.002 | 1770.000005 | 0.003 |

Frequency Error vs. Voltage

| Voltage (Vdc) | LTE Band 71 | | | |
|---------------|------------------------|-----------------------|-----------------|-----------------------|
| | Channel Bandwidth 5MHz | | | |
| | Low Channel | | High Channel | |
| | Frequency (MHz) | Frequency Error (ppm) | Frequency (MHz) | Frequency Error (ppm) |
| 3.4 | 665.499995 | -0.008 | 695.499996 | -0.006 |
| 4.0 | 665.500001 | 0.002 | 695.499995 | -0.007 |
| 4.6 | 665.499995 | -0.008 | 695.499995 | -0.007 |

Note: The applicant defined the normal working voltage is from 3.4Vdc to 4.6Vdc.

Frequency Error vs. Temperature

| Temp. (°C) | LTE Band 71 | | | |
|------------|------------------------|-----------------------|-----------------|-----------------------|
| | Channel Bandwidth 5MHz | | | |
| | Low Channel | | High Channel | |
| | Frequency (MHz) | Frequency Error (ppm) | Frequency (MHz) | Frequency Error (ppm) |
| -40 | 665.499995 | -0.008 | 695.499997 | -0.004 |
| -30 | 665.500001 | 0.002 | 695.499998 | -0.003 |
| -20 | 665.499999 | -0.002 | 695.500002 | 0.003 |
| -10 | 665.500001 | 0.002 | 695.500002 | 0.003 |
| 0 | 665.499996 | -0.006 | 695.499996 | -0.006 |
| 10 | 665.500005 | 0.008 | 695.499996 | -0.006 |
| 20 | 665.499999 | -0.002 | 695.499995 | -0.007 |
| 30 | 665.499995 | -0.008 | 695.500003 | 0.004 |
| 40 | 665.499995 | -0.008 | 695.499996 | -0.006 |
| 50 | 665.500003 | 0.005 | 695.499998 | -0.003 |
| 60 | 665.500005 | 0.008 | 695.500005 | 0.007 |
| 70 | 665.499995 | -0.008 | 695.499996 | -0.006 |
| 80 | 665.499997 | -0.005 | 695.499995 | -0.007 |
| 85 | 665.500001 | 0.002 | 695.499996 | -0.006 |

Frequency Error vs. Voltage

| Voltage (Vdc) | LTE Band 71 | | | |
|---------------|-------------------------|-----------------------|-----------------|-----------------------|
| | Channel Bandwidth 10MHz | | | |
| | Low Channel | | High Channel | |
| | Frequency (MHz) | Frequency Error (ppm) | Frequency (MHz) | Frequency Error (ppm) |
| 3.4 | 667.999999 | -0.001 | 693.000002 | 0.003 |
| 4.0 | 667.999996 | -0.006 | 693.000002 | 0.003 |
| 4.6 | 667.999996 | -0.006 | 692.999999 | -0.001 |

Note: The applicant defined the normal working voltage is from 3.4Vdc to 4.6Vdc.

Frequency Error vs. Temperature

| Temp. (°C) | LTE Band 71 | | | |
|------------|-------------------------|-----------------------|-----------------|-----------------------|
| | Channel Bandwidth 10MHz | | | |
| | Low Channel | | High Channel | |
| | Frequency (MHz) | Frequency Error (ppm) | Frequency (MHz) | Frequency Error (ppm) |
| -40 | 667.999995 | -0.007 | 693.000002 | 0.003 |
| -30 | 667.999999 | -0.001 | 692.999997 | -0.004 |
| -20 | 668.000005 | 0.007 | 693.000002 | 0.003 |
| -10 | 668.000002 | 0.003 | 692.999998 | -0.003 |
| 0 | 667.999998 | -0.003 | 693.000002 | 0.003 |
| 10 | 667.999999 | -0.001 | 692.999995 | -0.007 |
| 20 | 667.999998 | -0.003 | 693.000003 | 0.004 |
| 30 | 667.999997 | -0.004 | 693.000001 | 0.001 |
| 40 | 667.999997 | -0.004 | 692.999997 | -0.004 |
| 50 | 667.999995 | -0.007 | 692.999995 | -0.007 |
| 60 | 668.000001 | 0.001 | 692.999995 | -0.007 |
| 70 | 668.000005 | 0.007 | 692.999999 | -0.001 |
| 80 | 668.000002 | 0.003 | 693.000003 | 0.004 |
| 85 | 667.999998 | -0.003 | 693.000004 | 0.006 |

Frequency Error vs. Voltage

| Voltage (Vdc) | LTE Band 71 | | | |
|---------------|-------------------------|-----------------------|-----------------|-----------------------|
| | Channel Bandwidth 15MHz | | | |
| | Low Channel | | High Channel | |
| | Frequency (MHz) | Frequency Error (ppm) | Frequency (MHz) | Frequency Error (ppm) |
| 3.4 | 670.499995 | -0.007 | 690.500003 | 0.004 |
| 4.0 | 670.499998 | -0.003 | 690.500005 | 0.007 |
| 4.6 | 670.500005 | 0.007 | 690.499998 | -0.003 |

Note: The applicant defined the normal working voltage is from 3.4Vdc to 4.6Vdc.

Frequency Error vs. Temperature

| Temp. (°C) | LTE Band 71 | | | |
|------------|-------------------------|-----------------------|-----------------|-----------------------|
| | Channel Bandwidth 15MHz | | | |
| | Low Channel | | High Channel | |
| | Frequency (MHz) | Frequency Error (ppm) | Frequency (MHz) | Frequency Error (ppm) |
| -40 | 670.500002 | 0.003 | 690.499996 | -0.006 |
| -30 | 670.499996 | -0.006 | 690.500002 | 0.003 |
| -20 | 670.499999 | -0.001 | 690.500005 | 0.007 |
| -10 | 670.500001 | 0.001 | 690.500005 | 0.007 |
| 0 | 670.499995 | -0.007 | 690.500004 | 0.006 |
| 10 | 670.500001 | 0.001 | 690.499996 | -0.006 |
| 20 | 670.500003 | 0.004 | 690.500004 | 0.006 |
| 30 | 670.500003 | 0.004 | 690.499999 | -0.001 |
| 40 | 670.500005 | 0.007 | 690.500003 | 0.004 |
| 50 | 670.499996 | -0.006 | 690.500003 | 0.004 |
| 60 | 670.500005 | 0.007 | 690.500005 | 0.007 |
| 70 | 670.500005 | 0.007 | 690.500002 | 0.003 |
| 80 | 670.500004 | 0.006 | 690.500005 | 0.007 |
| 85 | 670.500004 | 0.006 | 690.499998 | -0.003 |

Frequency Error vs. Voltage

| Voltage (Vdc) | LTE Band 71 | | | |
|---------------|-------------------------|-----------------------|-----------------|-----------------------|
| | Channel Bandwidth 20MHz | | | |
| | Low Channel | | High Channel | |
| | Frequency (MHz) | Frequency Error (ppm) | Frequency (MHz) | Frequency Error (ppm) |
| 3.4 | 673.000004 | 0.006 | 688.000002 | 0.003 |
| 4.0 | 673.000005 | 0.007 | 688.000001 | 0.001 |
| 4.6 | 673.000001 | 0.001 | 688.000004 | 0.006 |

Note: The applicant defined the normal working voltage is from 3.4Vdc to 4.6Vdc.

Frequency Error vs. Temperature

| Temp. (°C) | LTE Band 71 | | | |
|------------|-------------------------|-----------------------|-----------------|-----------------------|
| | Channel Bandwidth 20MHz | | | |
| | Low Channel | | High Channel | |
| | Frequency (MHz) | Frequency Error (ppm) | Frequency (MHz) | Frequency Error (ppm) |
| -40 | 673.000001 | 0.001 | 687.999995 | -0.007 |
| -30 | 672.999996 | -0.006 | 688.000004 | 0.006 |
| -20 | 672.999998 | -0.003 | 687.999996 | -0.006 |
| -10 | 673.000003 | 0.004 | 687.999999 | -0.001 |
| 0 | 672.999997 | -0.004 | 688.000004 | 0.006 |
| 10 | 673.000001 | 0.001 | 688.000003 | 0.004 |
| 20 | 673.000002 | 0.003 | 688.000001 | 0.001 |
| 30 | 672.999998 | -0.003 | 687.999998 | -0.003 |
| 40 | 673.000002 | 0.003 | 687.999997 | -0.004 |
| 50 | 673.000003 | 0.004 | 688.000001 | 0.001 |
| 60 | 673.000003 | 0.004 | 688.000005 | 0.007 |
| 70 | 673.000005 | 0.007 | 687.999997 | -0.004 |
| 80 | 673.000001 | 0.001 | 687.999998 | -0.003 |
| 85 | 672.999998 | -0.003 | 688.000001 | 0.001 |

4.4 Occupied Bandwidth Measurement

4.4.1 Limits of Occupied Bandwidth Measurement

The occupied bandwidth (OBW), that is the frequency bandwidth such that, below its lower and above its upper frequency limits, the mean powers radiated are each equal to 0.5 % of the total mean power radiated by a given emission.

4.4.2 Test Procedure

For the 26dBc bandwidth measurement method, please refer to section 5.4.3 of ANSI C63.26.

- a) The spectrum analyzer center frequency is set to the nominal EUT channel center frequency. The span range for the spectrum analyzer shall be wide enough to see sufficient roll off of the signal to make the measurement.
- b) The nominal RBW shall be in the range of 1% to 5% of the anticipated OBW, and the VBW shall be set $\geq 3 \times$ RBW.
- c) Set the reference level of the instrument as required to prevent the signal amplitude from exceeding the maximum spectrum analyzer input mixer level for linear operation. See guidance provided in 4.2.3.
- d) The dynamic range of the spectrum analyzer at the selected RBW shall be more than 10 dB below the target “-X dB” requirement, i.e., if the requirement calls for measuring the -26 dB OBW, the spectrum analyzer noise floor at the selected RBW shall be at least 36 dB below the reference level.
- e) Set spectrum analyzer detection mode to peak, and the trace mode to max hold.
- f) Determine the following reference values: Set the EUT to transmit a modulated signal. Allow the trace to stabilize. Set the spectrum analyzer marker to the highest level of the displayed trace (this is the reference value).
- g) Determine the “-X dB amplitude” as equal to (Reference Value - X). Alternatively, this calculation can be performed on the spectrum analyzer using the delta-marker measurement function.
- h) Place two markers, one at the lowest and the other at the highest frequency of the envelope of the spectral display such that each marker is at or slightly below the “-X dB amplitude” determined in step f). If a marker is below this “-X dB amplitude” value it should be as close as possible to this value. The OBW is the positive frequency difference between the two markers.
- i) The OBW shall be reported by providing plot(s) of the measuring instrument display, to include markers depicting the relevant frequency and amplitude information (e.g., marker table). The frequency and amplitude axis and scale shall be clearly labeled. Tabular data may be reported in addition to the plot(s).

For the occupied bandwidth measurement method, please refer to section 5.4.4 of ANSI C63.26.

4.4.3 Test Setup

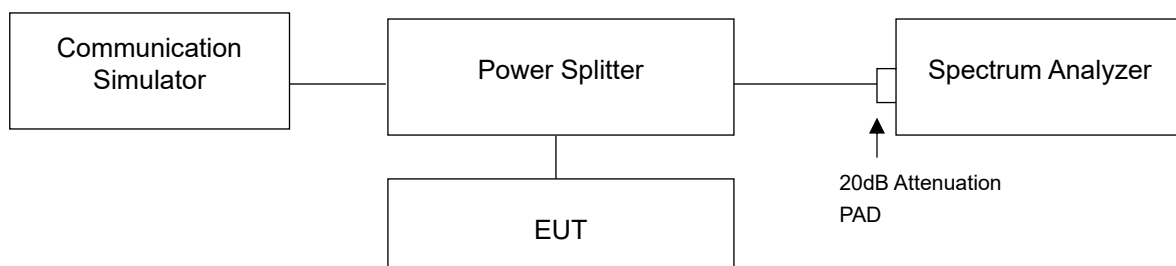

4.4.4 Test Result

LTE Band 4 (Channel Bandwidth 1.4MHz)

| Test Condition | Channel | Frequency (MHz) | Occupied bandwidth (MHz) | 26 dB Bandwidth (MHz) |
|----------------|---------|-----------------|--------------------------|-----------------------|
| QPSK | 19957 | 1710.7 | 1.0852 | 1.241 |
| QPSK | 20175 | 1732.5 | 1.0902 | 1.252 |
| QPSK | 20393 | 1754.3 | 1.0893 | 1.255 |
| 16QAM | 19957 | 1710.7 | 1.0871 | 1.251 |
| 16QAM | 20175 | 1732.5 | 1.0876 | 1.252 |
| 16QAM | 20393 | 1754.3 | 1.0864 | 1.248 |
| 64QAM | 19957 | 1710.7 | 1.0875 | 1.255 |
| 64QAM | 20175 | 1732.5 | 1.0875 | 1.247 |
| 64QAM | 20393 | 1754.3 | 1.0872 | 1.253 |

NOTE: For the test plots please refer to the below pages.

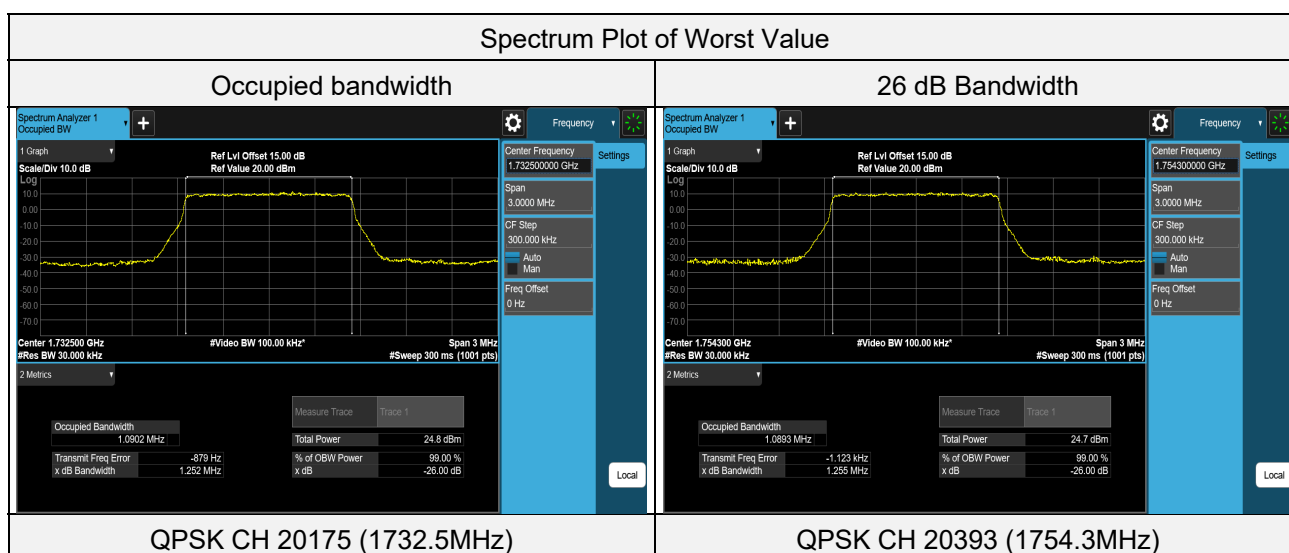

LTE Band 4 (Channel Bandwidth 3MHz)

| Test Condition | Channel | Frequency (MHz) | Occupied bandwidth (MHz) | 26 dB Bandwidth (MHz) |
|----------------|---------|-----------------|--------------------------|-----------------------|
| QPSK | 19965 | 1711.5 | 2.6901 | 2.857 |
| QPSK | 20175 | 1732.5 | 2.6927 | 2.861 |
| QPSK | 20385 | 1753.5 | 2.6933 | 2.863 |
| 16QAM | 19965 | 1711.5 | 2.6875 | 2.870 |
| 16QAM | 20175 | 1732.5 | 2.6903 | 2.865 |
| 16QAM | 20385 | 1753.5 | 2.6898 | 2.874 |
| 64QAM | 19965 | 1711.5 | 2.6900 | 2.861 |
| 64QAM | 20175 | 1732.5 | 2.6907 | 2.863 |
| 64QAM | 20385 | 1753.5 | 2.6901 | 2.860 |

NOTE: For the test plots please refer to the below pages.

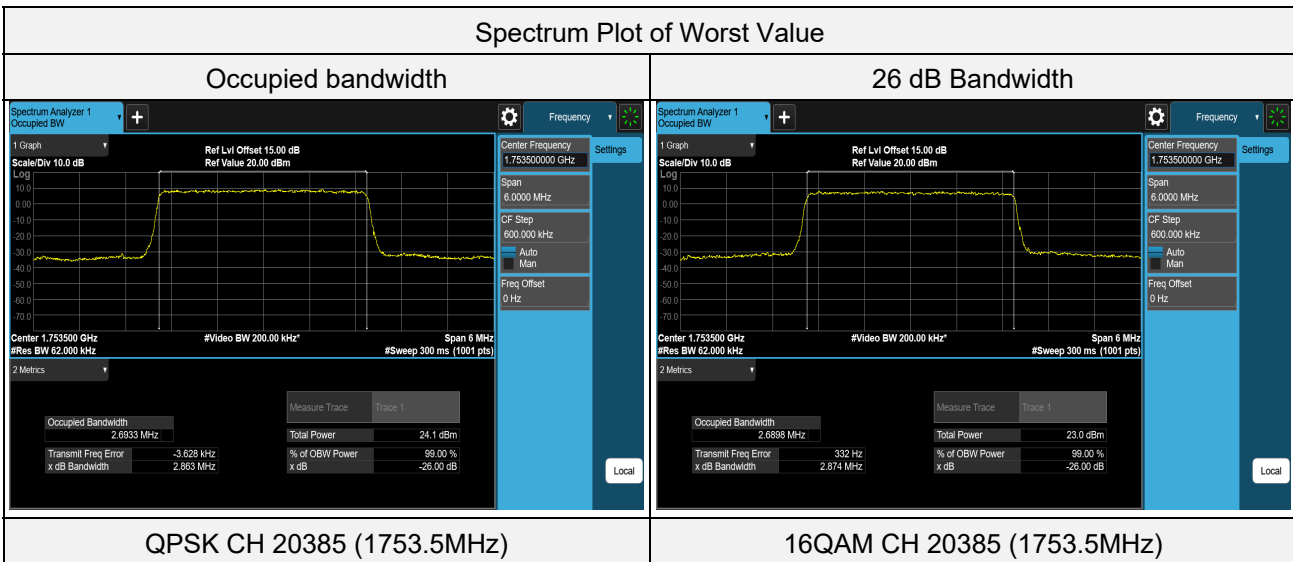

LTE Band 4 (Channel Bandwidth 5MHz)

| Test Condition | Channel | Frequency (MHz) | Occupied bandwidth (MHz) | 26 dB Bandwidth (MHz) |
|----------------|---------|-----------------|--------------------------|-----------------------|
| QPSK | 19975 | 1712.5 | 4.4959 | 4.784 |
| QPSK | 20175 | 1732.5 | 4.4929 | 4.778 |
| QPSK | 20375 | 1752.5 | 4.4936 | 4.781 |
| 16QAM | 19975 | 1712.5 | 4.4918 | 4.772 |
| 16QAM | 20175 | 1732.5 | 4.4902 | 4.785 |
| 16QAM | 20375 | 1752.5 | 4.4892 | 4.769 |
| 64QAM | 19975 | 1712.5 | 4.4928 | 4.778 |
| 64QAM | 20175 | 1732.5 | 4.4926 | 4.782 |
| 64QAM | 20375 | 1752.5 | 4.4964 | 4.779 |

NOTE: For the test plots please refer to the below pages.

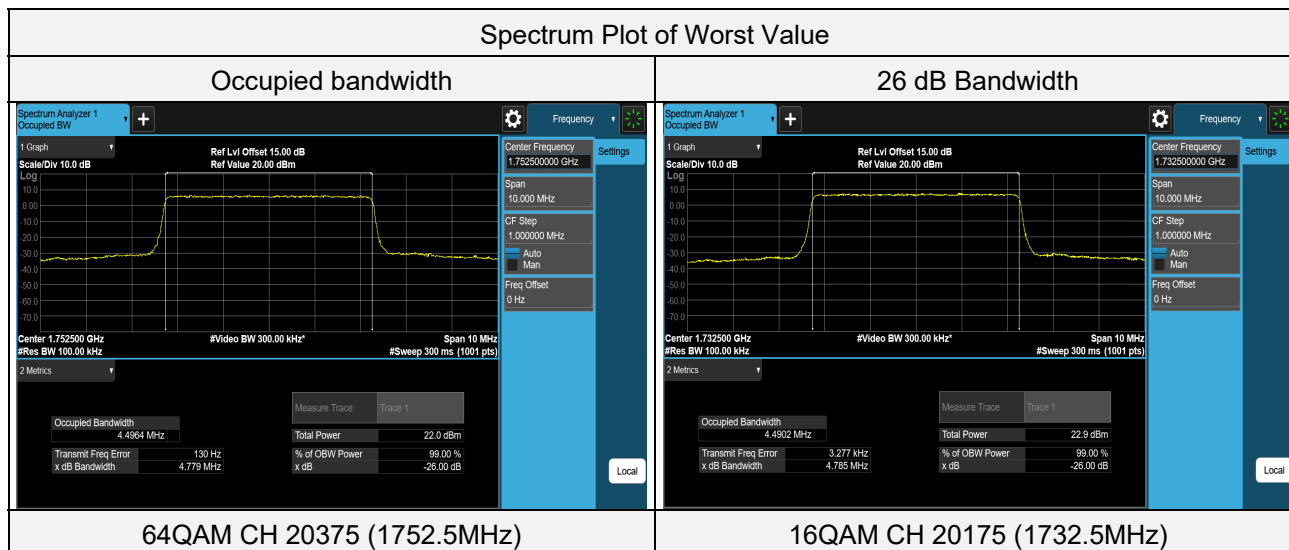

LTE Band 4 (Channel Bandwidth 10MHz)

| Test Condition | Channel | Frequency (MHz) | Occupied bandwidth (MHz) | 26 dB Bandwidth (MHz) |
|----------------|---------|-----------------|--------------------------|-----------------------|
| QPSK | 20000 | 1715 | 8.9800 | 9.507 |
| QPSK | 20175 | 1732.5 | 8.9822 | 9.492 |
| QPSK | 20350 | 1750 | 8.9753 | 9.496 |
| 16QAM | 20000 | 1715 | 8.9785 | 9.509 |
| 16QAM | 20175 | 1732.5 | 8.9776 | 9.501 |
| 16QAM | 20350 | 1750 | 8.9800 | 9.501 |
| 64QAM | 20000 | 1715 | 8.9803 | 9.509 |
| 64QAM | 20175 | 1732.5 | 8.9804 | 9.505 |
| 64QAM | 20350 | 1750 | 8.9787 | 9.505 |

NOTE: For the test plots please refer to the below pages.

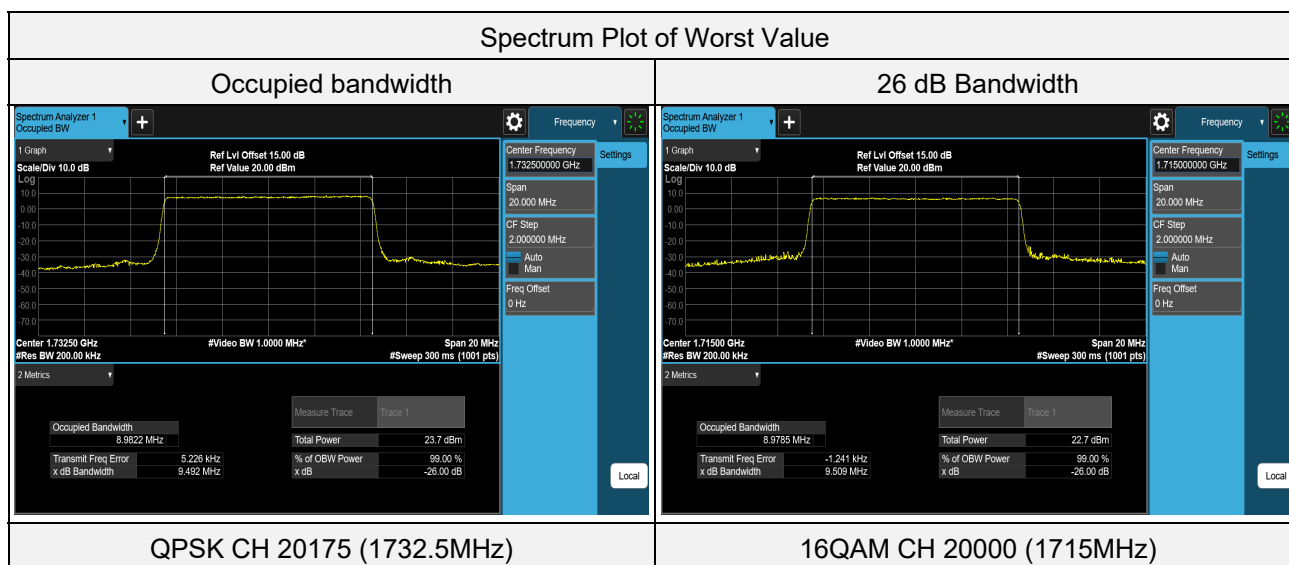

LTE Band 4 (Channel Bandwidth 15MHz)

| Test Condition | Channel | Frequency (MHz) | Occupied bandwidth (MHz) | 26 dB Bandwidth (MHz) |
|----------------|---------|-----------------|--------------------------|-----------------------|
| QPSK | 20025 | 1717.5 | 13.4739 | 14.236 |
| QPSK | 20175 | 1732.5 | 13.4685 | 14.224 |
| QPSK | 20325 | 1747.5 | 13.4664 | 14.222 |
| 16QAM | 20025 | 1717.5 | 13.4616 | 14.244 |
| 16QAM | 20175 | 1732.5 | 13.4558 | 14.241 |
| 16QAM | 20325 | 1747.5 | 13.4495 | 14.229 |
| 64QAM | 20025 | 1717.5 | 13.4563 | 14.229 |
| 64QAM | 20175 | 1732.5 | 13.4495 | 14.220 |
| 64QAM | 20325 | 1747.5 | 13.4469 | 14.230 |

NOTE: For the test plots please refer to the below pages.

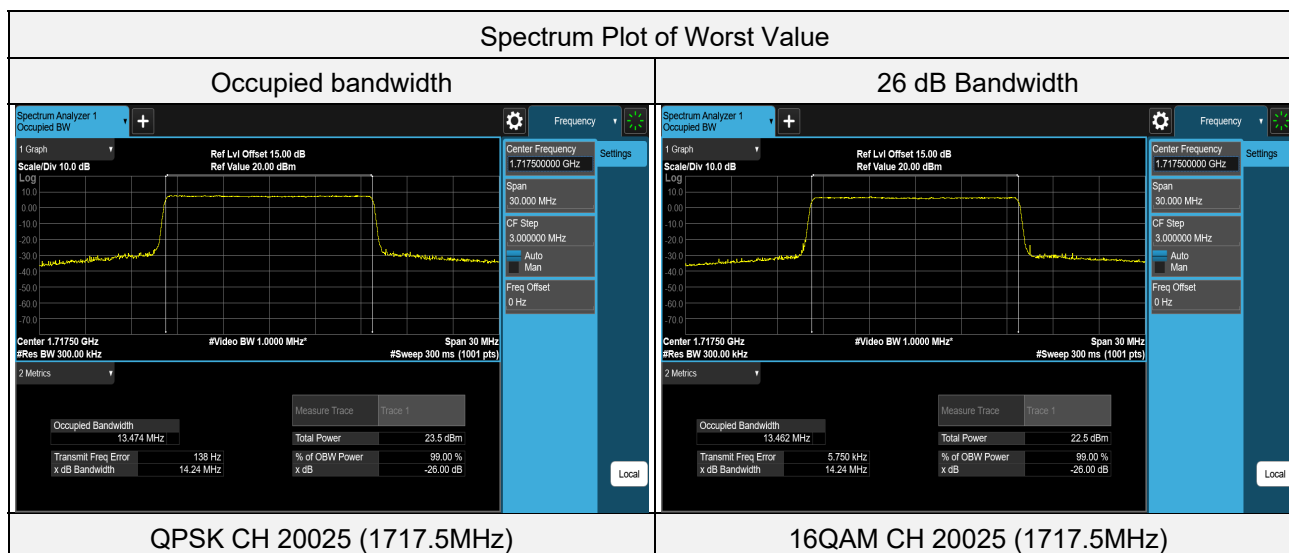

LTE Band 4 (Channel Bandwidth 20MHz)

| Test Condition | Channel | Frequency (MHz) | Occupied bandwidth (MHz) | 26 dB Bandwidth (MHz) |
|----------------|---------|-----------------|--------------------------|-----------------------|
| QPSK | 20050 | 1720 | 17.9608 | 19.033 |
| QPSK | 20175 | 1732.5 | 17.9478 | 19.018 |
| QPSK | 20300 | 1745 | 17.9382 | 19.019 |
| 16QAM | 20050 | 1720 | 17.9819 | 19.036 |
| 16QAM | 20175 | 1732.5 | 17.9664 | 19.025 |
| 16QAM | 20300 | 1745 | 17.9482 | 19.035 |
| 64QAM | 20050 | 1720 | 17.9610 | 19.033 |
| 64QAM | 20175 | 1732.5 | 17.9557 | 19.020 |
| 64QAM | 20300 | 1745 | 17.9463 | 19.030 |

NOTE: For the test plots please refer to the below pages.

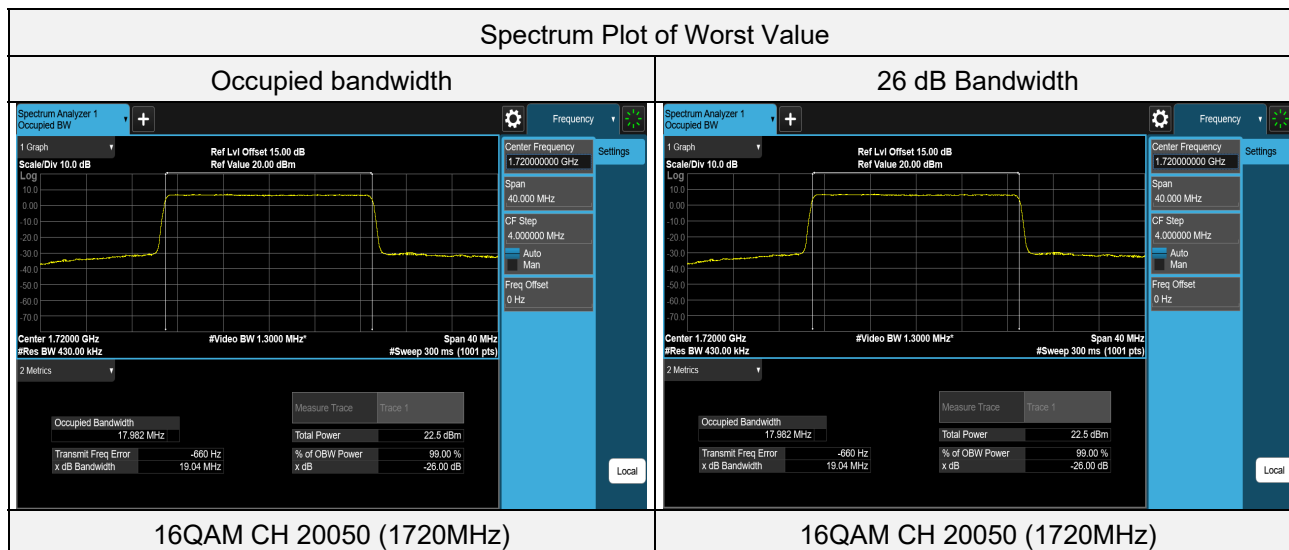

LTE Band 7 (Channel Bandwidth 5MHz)

| Test Condition | Channel | Frequency (MHz) | Occupied bandwidth (MHz) | 26 dB Bandwidth (MHz) |
|----------------|---------|-----------------|--------------------------|-----------------------|
| QPSK | 20775 | 2502.5 | 4.4958 | 4.783 |
| QPSK | 21100 | 2535 | 4.4926 | 4.769 |
| QPSK | 21425 | 2567.5 | 4.4918 | 4.775 |
| 16QAM | 20775 | 2502.5 | 4.4901 | 4.772 |
| 16QAM | 21100 | 2535 | 4.4939 | 4.770 |
| 16QAM | 21425 | 2567.5 | 4.4917 | 4.767 |
| 64QAM | 20775 | 2502.5 | 4.4952 | 4.776 |
| 64QAM | 21100 | 2535 | 4.4920 | 4.764 |
| 64QAM | 21425 | 2567.5 | 4.4960 | 4.779 |

NOTE: For the test plots please refer to the below pages.

Spectrum Plot of Worst Value

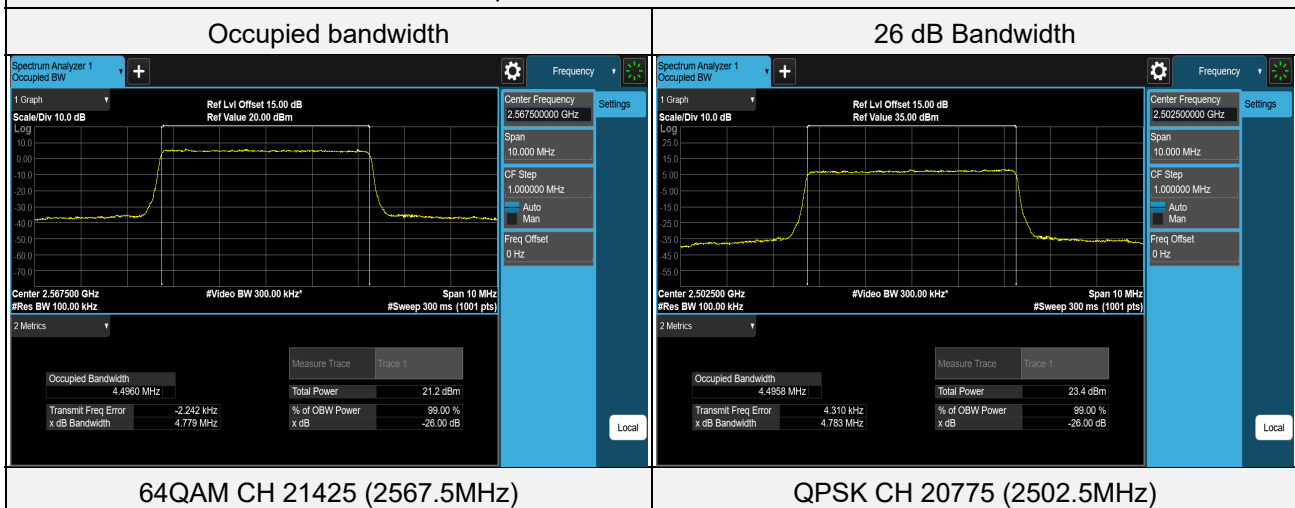

LTE Band 7 (Channel Bandwidth 10MHz)

| Test Condition | Channel | Frequency (MHz) | Occupied bandwidth (MHz) | 26 dB Bandwidth (MHz) |
|----------------|---------|-----------------|--------------------------|-----------------------|
| QPSK | 20800 | 2505 | 8.9729 | 9.483 |
| QPSK | 21100 | 2535 | 8.9845 | 9.503 |
| QPSK | 21400 | 2565 | 8.9822 | 9.500 |
| 16QAM | 20800 | 2505 | 8.9758 | 9.478 |
| 16QAM | 21100 | 2535 | 8.9847 | 9.501 |
| 16QAM | 21400 | 2565 | 8.9886 | 9.490 |
| 64QAM | 20800 | 2505 | 8.9716 | 9.491 |
| 64QAM | 21100 | 2535 | 8.9857 | 9.515 |
| 64QAM | 21400 | 2565 | 8.9845 | 9.509 |

NOTE: For the test plots please refer to the below pages.

Spectrum Plot of Worst Value

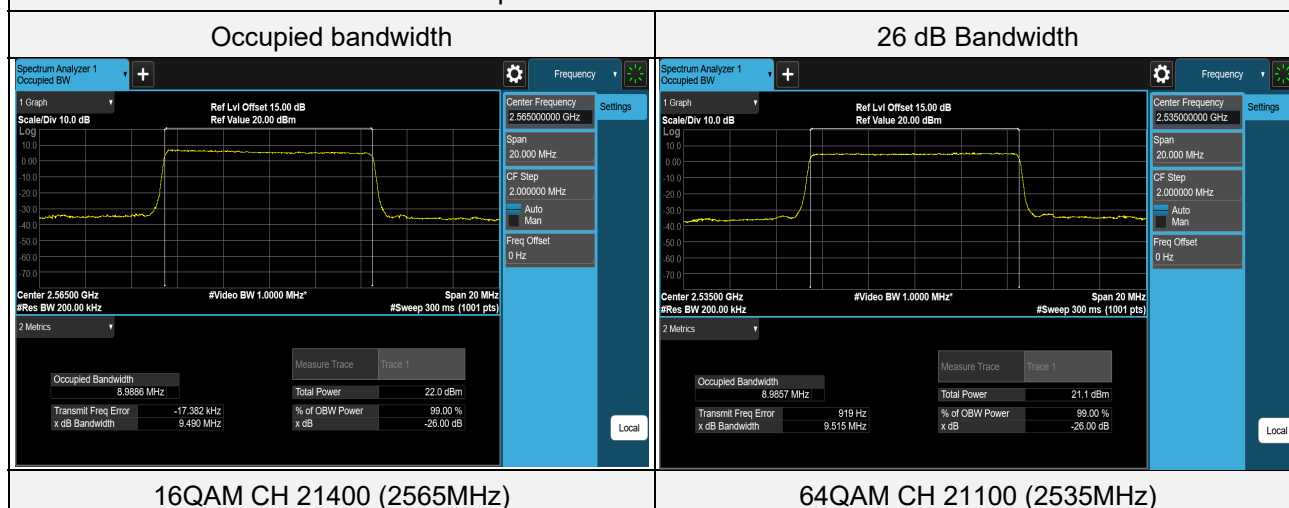

LTE Band 7 (Channel Bandwidth 15MHz)

| Test Condition | Channel | Frequency (MHz) | Occupied bandwidth (MHz) | 26 dB Bandwidth (MHz) |
|----------------|---------|-----------------|--------------------------|-----------------------|
| QPSK | 20825 | 2507.5 | 13.4468 | 14.203 |
| QPSK | 21100 | 2535 | 13.4856 | 14.225 |
| QPSK | 21375 | 2562.5 | 13.4709 | 14.198 |
| 16QAM | 20825 | 2507.5 | 13.4351 | 14.201 |
| 16QAM | 21100 | 2535 | 13.4760 | 14.233 |
| 16QAM | 21375 | 2562.5 | 13.4518 | 14.201 |
| 64QAM | 20825 | 2507.5 | 13.4270 | 14.194 |
| 64QAM | 21100 | 2535 | 13.4729 | 14.234 |
| 64QAM | 21375 | 2562.5 | 13.4511 | 14.200 |

NOTE: For the test plots please refer to the below pages.

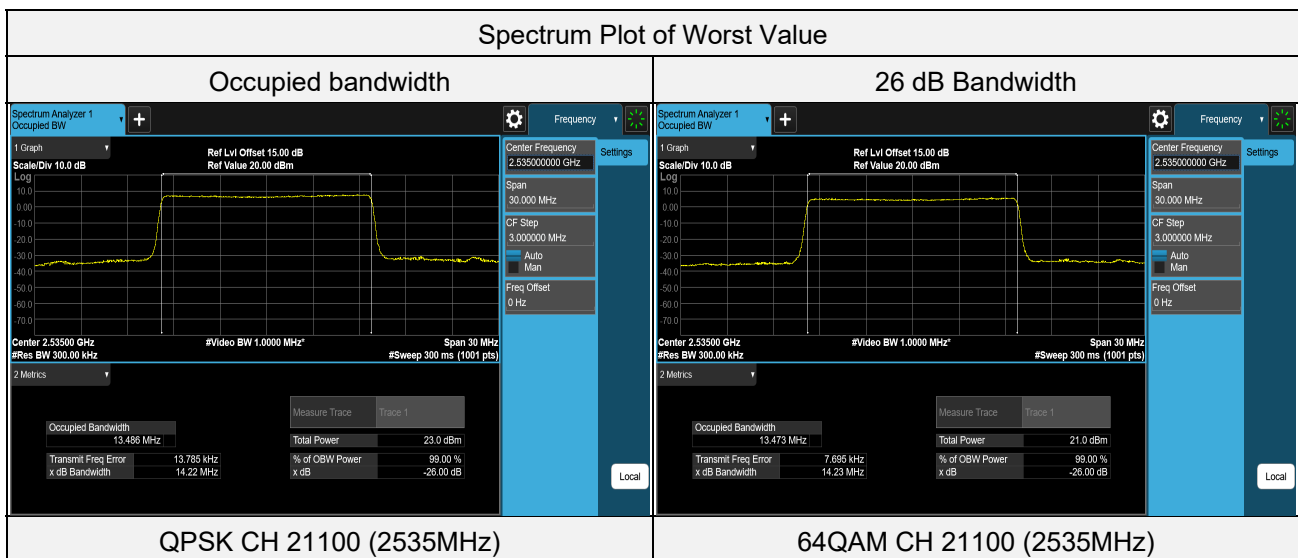

LTE Band 7 (Channel Bandwidth 20MHz)

| Test Condition | Channel | Frequency (MHz) | Occupied bandwidth (MHz) | 26 dB Bandwidth (MHz) |
|----------------|---------|-----------------|--------------------------|-----------------------|
| QPSK | 20850 | 2510 | 17.8697 | 18.984 |
| QPSK | 21100 | 2535 | 18.0004 | 19.033 |
| QPSK | 21350 | 2560 | 17.8973 | 18.976 |
| 16QAM | 20850 | 2510 | 17.8944 | 18.989 |
| 16QAM | 21100 | 2535 | 18.0076 | 19.038 |
| 16QAM | 21350 | 2560 | 17.9095 | 18.980 |
| 64QAM | 20850 | 2510 | 17.8807 | 18.979 |
| 64QAM | 21100 | 2535 | 18.0035 | 19.033 |
| 64QAM | 21350 | 2560 | 17.9054 | 18.977 |

NOTE: For the test plots please refer to the below pages.

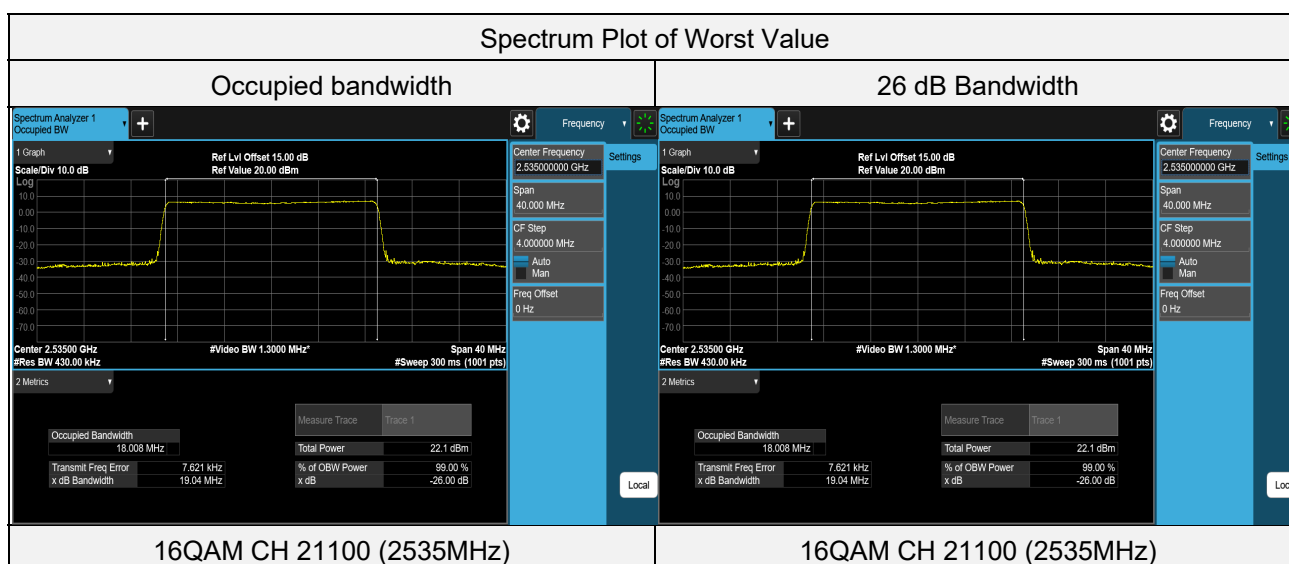

LTE Band 12 (Channel Bandwidth 1.4MHz)

| Test Condition | Channel | Frequency (MHz) | Occupied bandwidth (MHz) | 26 dB Bandwidth (MHz) |
|----------------|---------|-----------------|--------------------------|-----------------------|
| QPSK | 23017 | 699.7 | 1.0857 | 1.242 |
| QPSK | 23095 | 707.5 | 1.0904 | 1.265 |
| QPSK | 23173 | 715.3 | 1.0889 | 1.248 |
| 16QAM | 23017 | 699.7 | 1.0865 | 1.250 |
| 16QAM | 23095 | 707.5 | 1.0870 | 1.249 |
| 16QAM | 23173 | 715.3 | 1.0859 | 1.250 |
| 64QAM | 23017 | 699.7 | 1.0885 | 1.248 |
| 64QAM | 23095 | 707.5 | 1.0884 | 1.251 |
| 64QAM | 23173 | 715.3 | 1.0870 | 1.257 |

NOTE: For the test plots please refer to the below pages.

Spectrum Plot of Worst Value

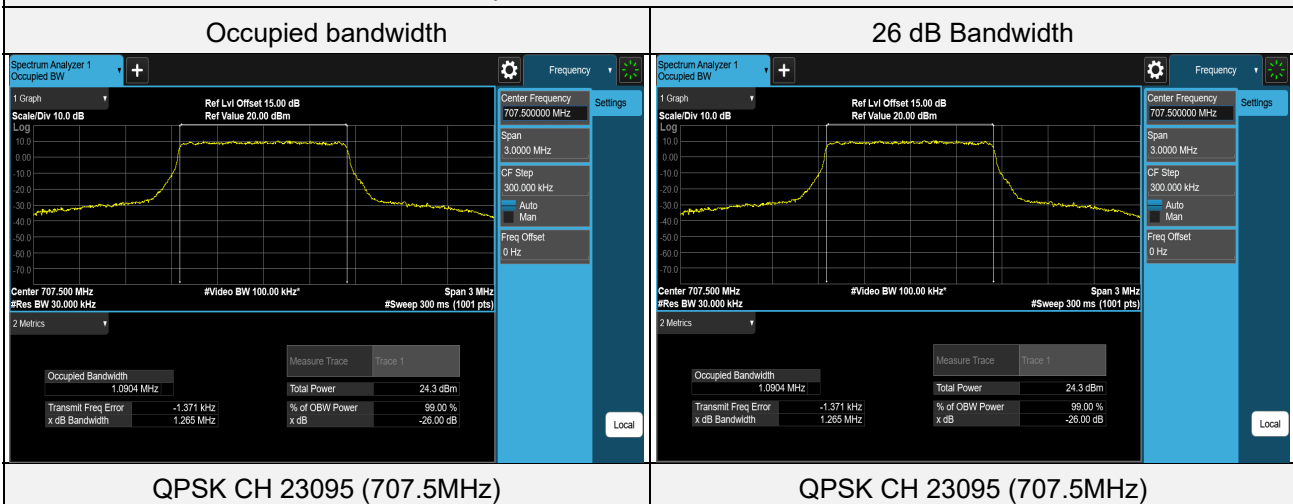

LTE Band 12 (Channel Bandwidth 3MHz)

| Test Condition | Channel | Frequency (MHz) | Occupied bandwidth (MHz) | 26 dB Bandwidth (MHz) |
|----------------|---------|-----------------|--------------------------|-----------------------|
| QPSK | 23025 | 700.5 | 2.6923 | 2.863 |
| QPSK | 23095 | 707.5 | 2.6928 | 2.878 |
| QPSK | 23165 | 714.5 | 2.6901 | 2.858 |
| 16QAM | 23025 | 700.5 | 2.6913 | 2.876 |
| 16QAM | 23095 | 707.5 | 2.6901 | 2.870 |
| 16QAM | 23165 | 714.5 | 2.6864 | 2.865 |
| 64QAM | 23025 | 700.5 | 2.6928 | 2.860 |
| 64QAM | 23095 | 707.5 | 2.6925 | 2.862 |
| 64QAM | 23165 | 714.5 | 2.6877 | 2.852 |

NOTE: For the test plots please refer to the below pages.

Spectrum Plot of Worst Value

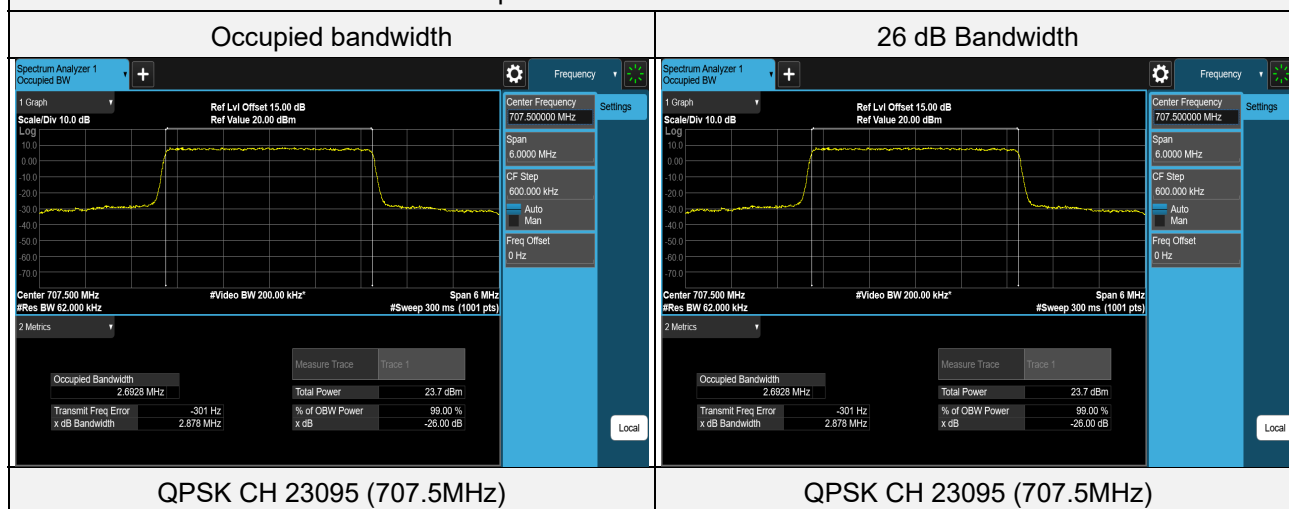

LTE Band 12 (Channel Bandwidth 5MHz)

| Test Condition | Channel | Frequency (MHz) | Occupied bandwidth (MHz) | 26 dB Bandwidth (MHz) |
|----------------|---------|-----------------|--------------------------|-----------------------|
| QPSK | 23035 | 701.5 | 4.4917 | 4.858 |
| QPSK | 23095 | 707.5 | 4.5047 | 4.915 |
| QPSK | 23155 | 713.5 | 4.4873 | 4.839 |
| 16QAM | 23035 | 701.5 | 4.4860 | 4.857 |
| 16QAM | 23095 | 707.5 | 4.5021 | 4.878 |
| 16QAM | 23155 | 713.5 | 4.4872 | 4.841 |
| 64QAM | 23035 | 701.5 | 4.4894 | 4.844 |
| 64QAM | 23095 | 707.5 | 4.5031 | 4.900 |
| 64QAM | 23155 | 713.5 | 4.4925 | 4.856 |

NOTE: For the test plots please refer to the below pages.

Spectrum Plot of Worst Value

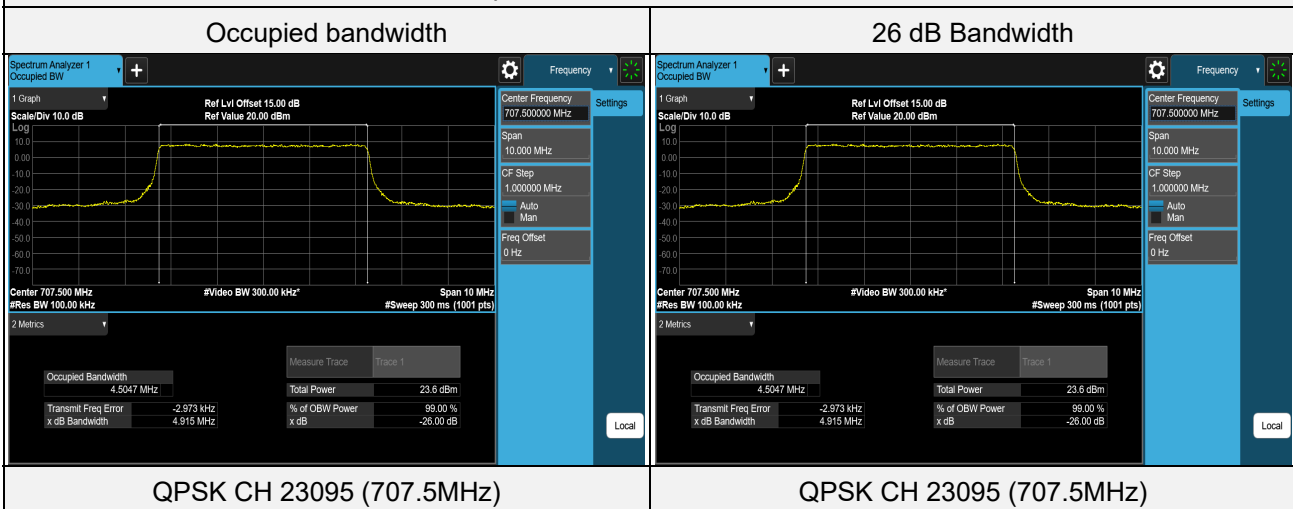

LTE Band 12 (Channel Bandwidth 10MHz)

| Test Condition | Channel | Frequency (MHz) | Occupied bandwidth (MHz) | 26 dB Bandwidth (MHz) |
|----------------|---------|-----------------|--------------------------|-----------------------|
| QPSK | 23060 | 704 | 8.9639 | 9.513 |
| QPSK | 23095 | 707.5 | 9.0119 | 9.561 |
| QPSK | 23130 | 711 | 8.9768 | 9.535 |
| 16QAM | 23060 | 704 | 8.9614 | 9.496 |
| 16QAM | 23095 | 707.5 | 9.0086 | 9.549 |
| 16QAM | 23130 | 711 | 8.9734 | 9.518 |
| 64QAM | 23060 | 704 | 8.9666 | 9.537 |
| 64QAM | 23095 | 707.5 | 9.0118 | 9.575 |
| 64QAM | 23130 | 711 | 8.9755 | 9.548 |

NOTE: For the test plots please refer to the below pages.

Spectrum Plot of Worst Value

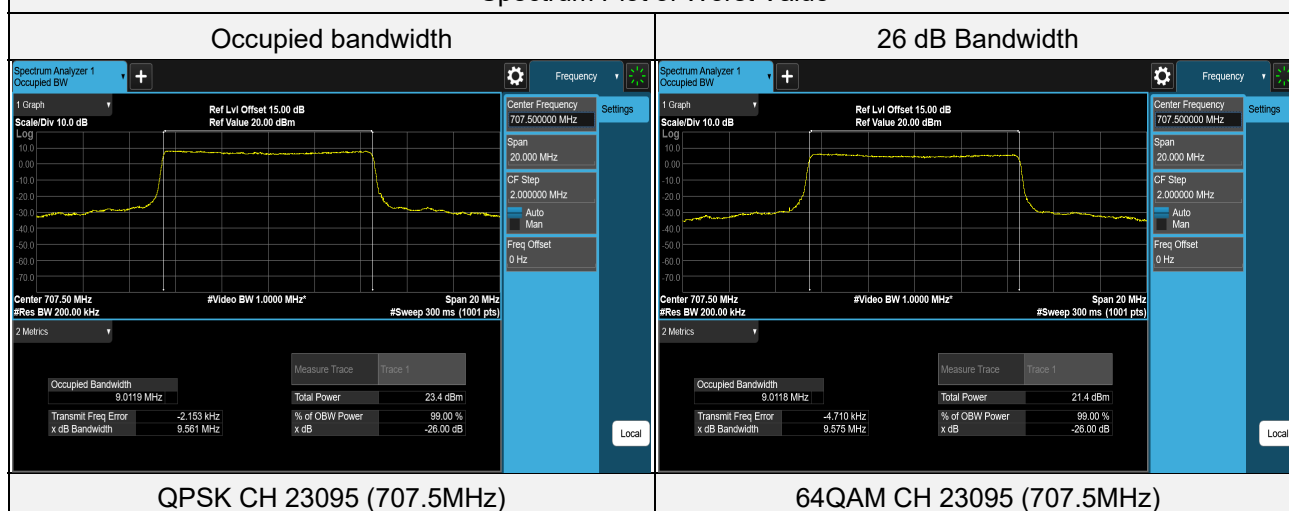

LTE Band 17 (Channel Bandwidth 5MHz)

| Test Condition | Channel | Frequency (MHz) | Occupied bandwidth (MHz) | 26 dB Bandwidth (MHz) |
|----------------|---------|-----------------|--------------------------|-----------------------|
| QPSK | 23755 | 706.5 | 4.4978 | 4.889 |
| QPSK | 23790 | 710 | 4.5009 | 4.868 |
| QPSK | 23825 | 713.5 | 4.4877 | 4.855 |
| 16QAM | 23755 | 706.5 | 4.5003 | 4.871 |
| 16QAM | 23790 | 710 | 4.4996 | 4.863 |
| 16QAM | 23825 | 713.5 | 4.4857 | 4.834 |
| 64QAM | 23755 | 706.5 | 4.5045 | 4.881 |
| 64QAM | 23790 | 710 | 4.5015 | 4.862 |
| 64QAM | 23825 | 713.5 | 4.4846 | 4.854 |

NOTE: For the test plots please refer to the below pages.

Spectrum Plot of Worst Value

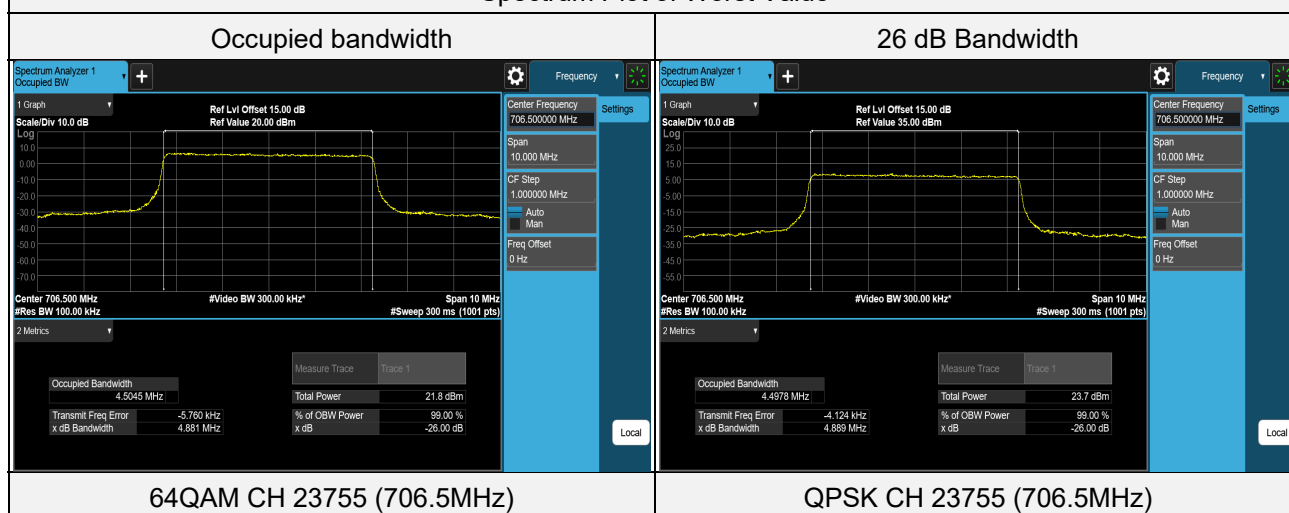

LTE Band 17 (Channel Bandwidth 10MHz)

| Test Condition | Channel | Frequency (MHz) | Occupied bandwidth (MHz) | 26 dB Bandwidth (MHz) |
|----------------|---------|-----------------|--------------------------|-----------------------|
| QPSK | 23780 | 709 | 9.0043 | 9.594 |
| QPSK | 23790 | 710 | 8.9893 | 9.520 |
| QPSK | 23800 | 711 | 8.9774 | 9.541 |
| 16QAM | 23780 | 709 | 9.0002 | 9.549 |
| 16QAM | 23790 | 710 | 8.9919 | 9.536 |
| 16QAM | 23800 | 711 | 8.9696 | 9.521 |
| 64QAM | 23780 | 709 | 9.0072 | 9.589 |
| 64QAM | 23790 | 710 | 8.9902 | 9.556 |
| 64QAM | 23800 | 711 | 8.9758 | 9.533 |

NOTE: For the test plots please refer to the below pages.

Spectrum Plot of Worst Value

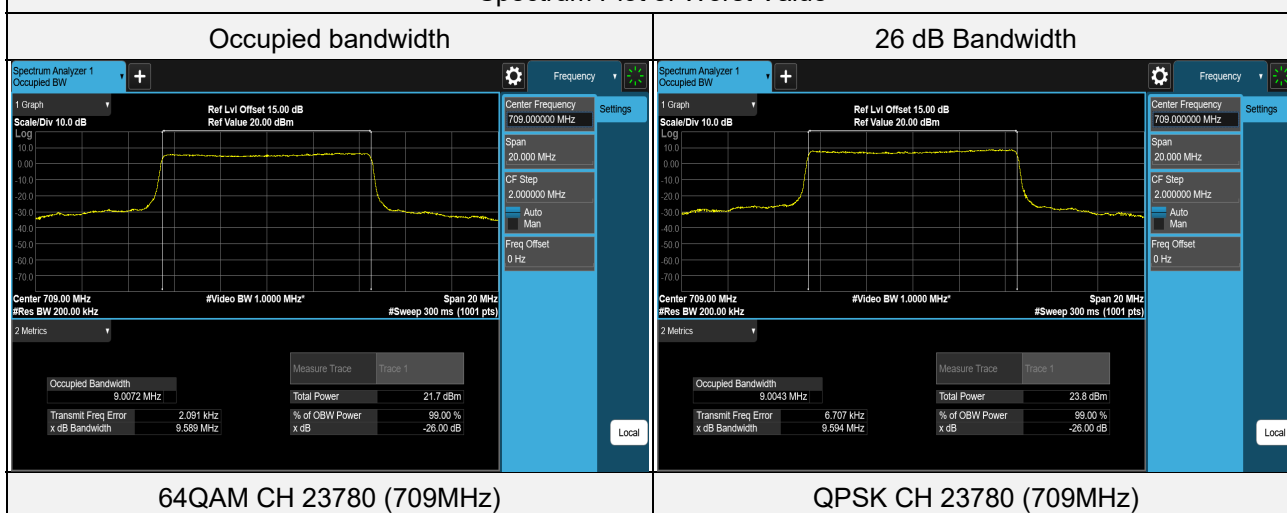

LTE Band 66 (Channel Bandwidth 1.4MHz)

| Test Condition | Channel | Frequency (MHz) | Occupied bandwidth (MHz) | 26 dB Bandwidth (MHz) |
|----------------|---------|-----------------|--------------------------|-----------------------|
| QPSK | 131979 | 1710.7 | 1.0881 | 1.262 |
| QPSK | 132322 | 1745 | 1.0893 | 1.254 |
| QPSK | 132665 | 1779.3 | 1.0889 | 1.258 |
| 16QAM | 131979 | 1710.7 | 1.0870 | 1.255 |
| 16QAM | 132322 | 1745 | 1.0870 | 1.248 |
| 16QAM | 132665 | 1779.3 | 1.0877 | 1.251 |
| 64QAM | 131979 | 1710.7 | 1.0877 | 1.252 |
| 64QAM | 132322 | 1745 | 1.0875 | 1.253 |
| 64QAM | 132665 | 1779.3 | 1.0883 | 1.254 |

NOTE: For the test plots please refer to the below pages.

Spectrum Plot of Worst Value

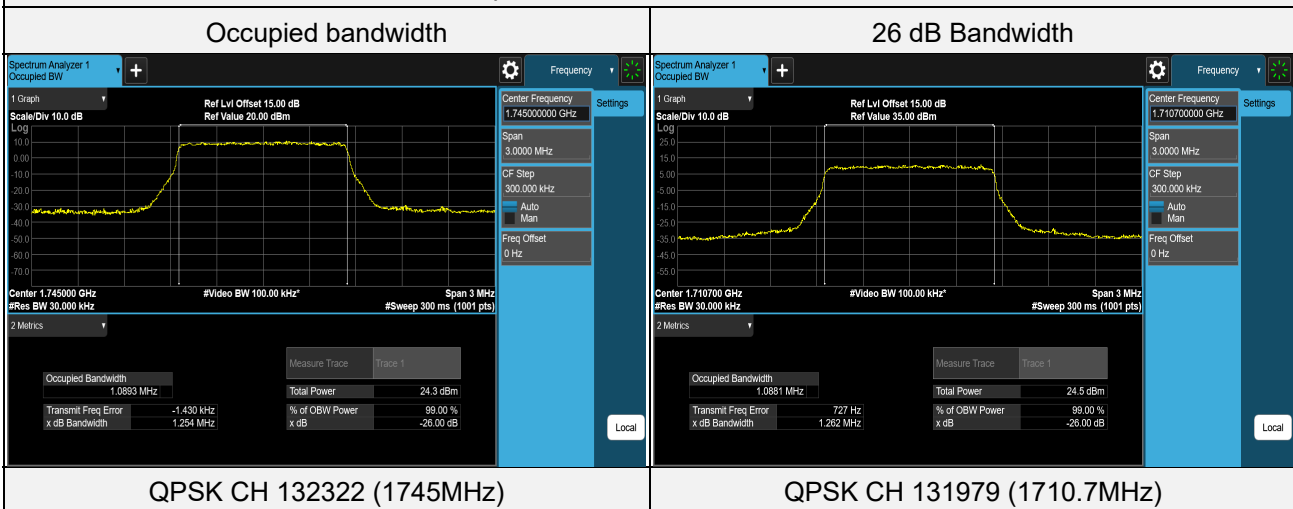

LTE Band 66 (Channel Bandwidth 3MHz)

| Test Condition | Channel | Frequency (MHz) | Occupied bandwidth (MHz) | 26 dB Bandwidth (MHz) |
|----------------|---------|-----------------|--------------------------|-----------------------|
| QPSK | 131987 | 1711.5 | 2.6918 | 2.870 |
| QPSK | 132322 | 1745 | 2.6932 | 2.868 |
| QPSK | 132657 | 1778.5 | 2.6886 | 2.861 |
| 16QAM | 131987 | 1711.5 | 2.6925 | 2.862 |
| 16QAM | 132322 | 1745 | 2.6919 | 2.859 |
| 16QAM | 132657 | 1778.5 | 2.6895 | 2.874 |
| 64QAM | 131987 | 1711.5 | 2.6910 | 2.863 |
| 64QAM | 132322 | 1745 | 2.6926 | 2.865 |
| 64QAM | 132657 | 1778.5 | 2.6921 | 2.860 |

NOTE: For the test plots please refer to the below pages.

Spectrum Plot of Worst Value

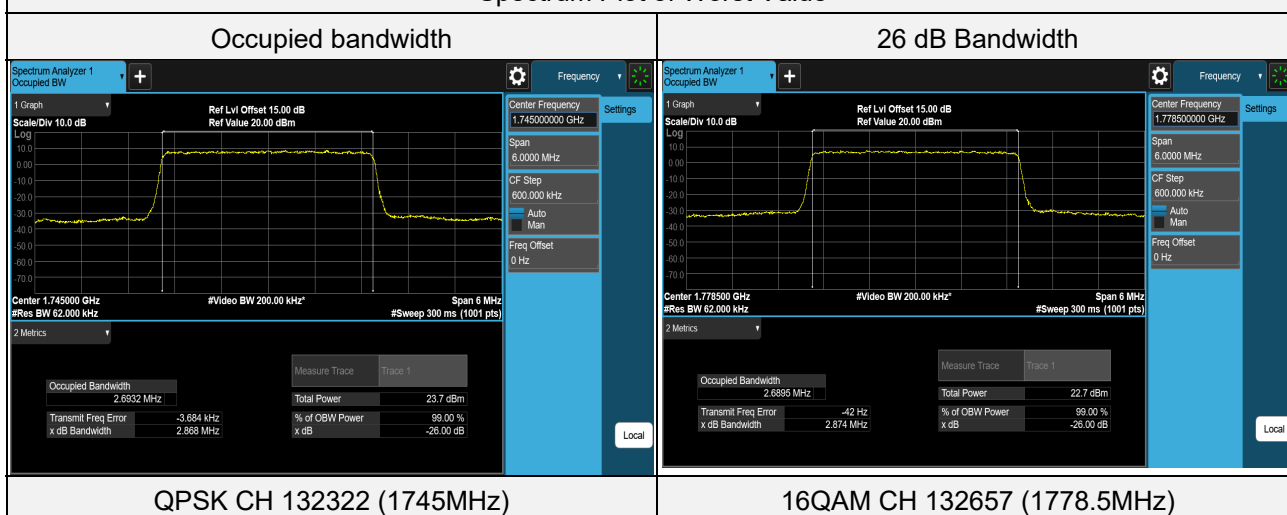

LTE Band 66 (Channel Bandwidth 5MHz)

| Test Condition | Channel | Frequency (MHz) | Occupied bandwidth (MHz) | 26 dB Bandwidth (MHz) |
|----------------|---------|-----------------|--------------------------|-----------------------|
| QPSK | 131997 | 1712.5 | 4.4971 | 4.867 |
| QPSK | 132322 | 1745 | 4.4956 | 4.861 |
| QPSK | 132647 | 1777.5 | 4.4966 | 4.860 |
| 16QAM | 131997 | 1712.5 | 4.4910 | 4.866 |
| 16QAM | 132322 | 1745 | 4.4916 | 4.882 |
| 16QAM | 132647 | 1777.5 | 4.4935 | 4.875 |
| 64QAM | 131997 | 1712.5 | 4.4979 | 4.868 |
| 64QAM | 132322 | 1745 | 4.4996 | 4.862 |
| 64QAM | 132647 | 1777.5 | 4.4983 | 4.873 |

NOTE: For the test plots please refer to the below pages.

Spectrum Plot of Worst Value

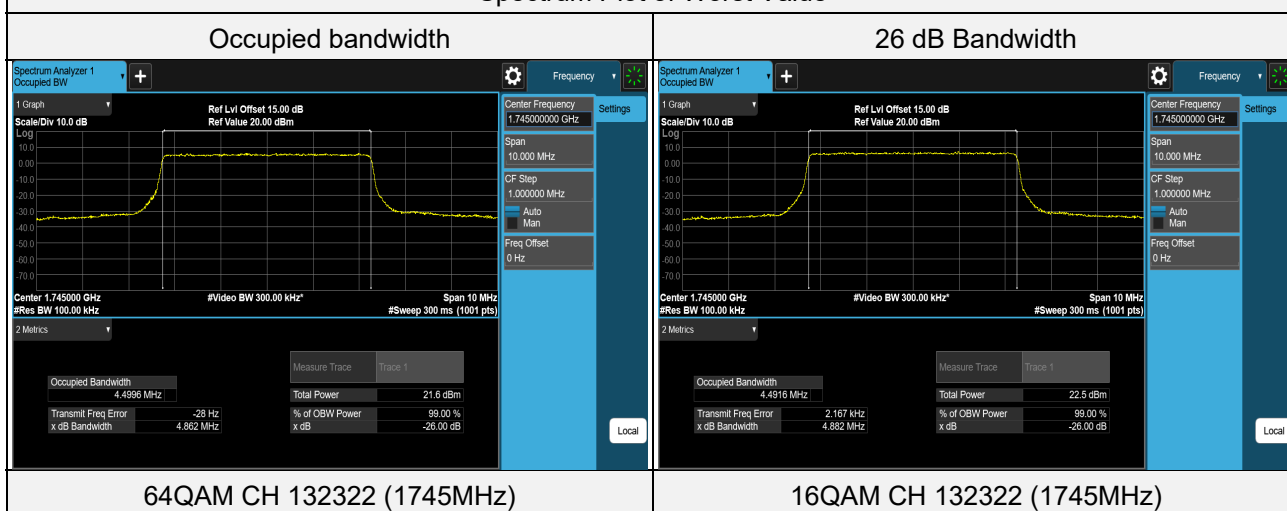

LTE Band 66 (Channel Bandwidth 10MHz)

| Test Condition | Channel | Frequency (MHz) | Occupied bandwidth (MHz) | 26 dB Bandwidth (MHz) |
|----------------|---------|-----------------|--------------------------|-----------------------|
| QPSK | 132022 | 1715 | 8.9829 | 9.554 |
| QPSK | 132322 | 1745 | 8.9782 | 9.570 |
| QPSK | 132622 | 1775 | 8.9829 | 9.573 |
| 16QAM | 132022 | 1715 | 8.9797 | 9.526 |
| 16QAM | 132322 | 1745 | 8.9812 | 9.523 |
| 16QAM | 132622 | 1775 | 8.9765 | 9.540 |
| 64QAM | 132022 | 1715 | 8.9808 | 9.603 |
| 64QAM | 132322 | 1745 | 8.9811 | 9.561 |
| 64QAM | 132622 | 1775 | 8.9812 | 9.561 |

NOTE: For the test plots please refer to the below pages.

Spectrum Plot of Worst Value

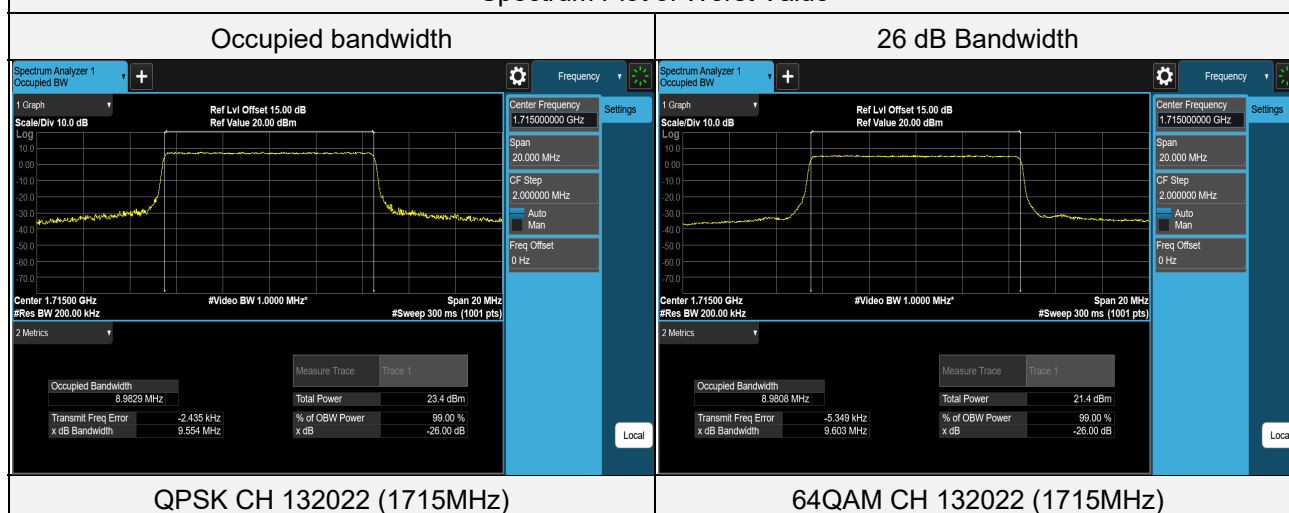

LTE Band 66 (Channel Bandwidth 15MHz)

| Test Condition | Channel | Frequency (MHz) | Occupied bandwidth (MHz) | 26 dB Bandwidth (MHz) |
|----------------|---------|-----------------|--------------------------|-----------------------|
| QPSK | 132047 | 1717.5 | 13.4772 | 14.270 |
| QPSK | 132322 | 1745 | 13.4717 | 14.256 |
| QPSK | 132597 | 1772.5 | 13.4603 | 14.261 |
| 16QAM | 132047 | 1717.5 | 13.4634 | 14.291 |
| 16QAM | 132322 | 1745 | 13.4495 | 14.266 |
| 16QAM | 132597 | 1772.5 | 13.4559 | 14.266 |
| 64QAM | 132047 | 1717.5 | 13.4593 | 14.288 |
| 64QAM | 132322 | 1745 | 13.4516 | 14.301 |
| 64QAM | 132597 | 1772.5 | 13.4501 | 14.279 |

NOTE: For the test plots please refer to the below pages.

Spectrum Plot of Worst Value

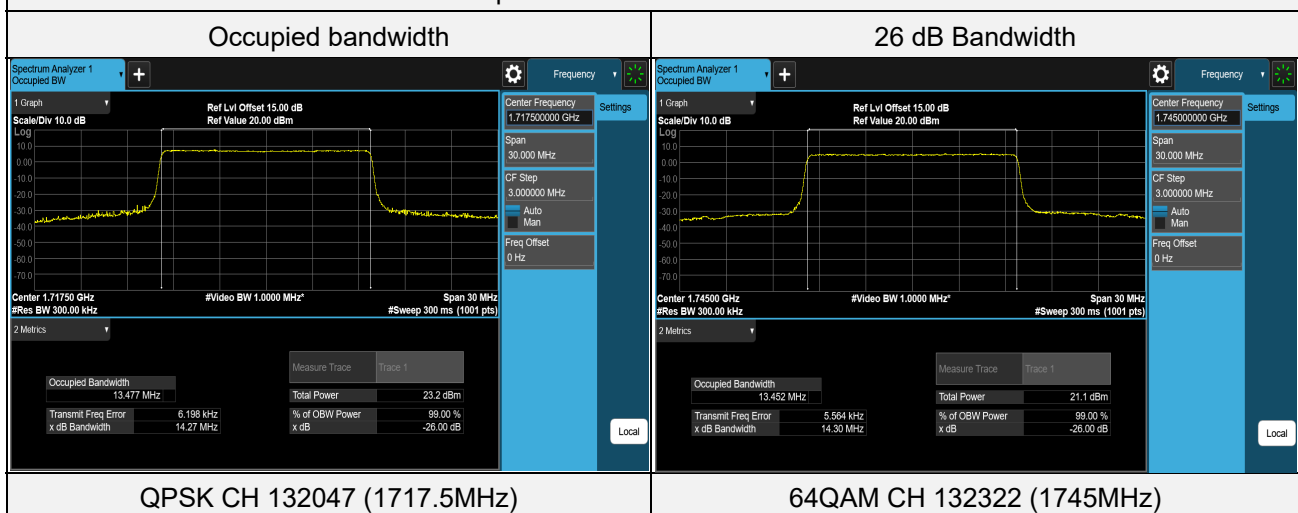

LTE Band 66 (Channel Bandwidth 20MHz)

| Test Condition | Channel | Frequency (MHz) | Occupied bandwidth (MHz) | 26 dB Bandwidth (MHz) |
|----------------|---------|-----------------|--------------------------|-----------------------|
| QPSK | 132072 | 1720 | 17.9663 | 19.047 |
| QPSK | 132322 | 1745 | 17.9457 | 19.051 |
| QPSK | 132572 | 1770 | 17.9478 | 19.046 |
| 16QAM | 132072 | 1720 | 17.9764 | 19.060 |
| 16QAM | 132322 | 1745 | 17.9499 | 19.042 |
| 16QAM | 132572 | 1770 | 17.9619 | 19.036 |
| 64QAM | 132072 | 1720 | 17.9635 | 19.066 |
| 64QAM | 132322 | 1745 | 17.9504 | 19.046 |
| 64QAM | 132572 | 1770 | 17.9546 | 19.058 |

NOTE: For the test plots please refer to the below pages.

Spectrum Plot of Worst Value

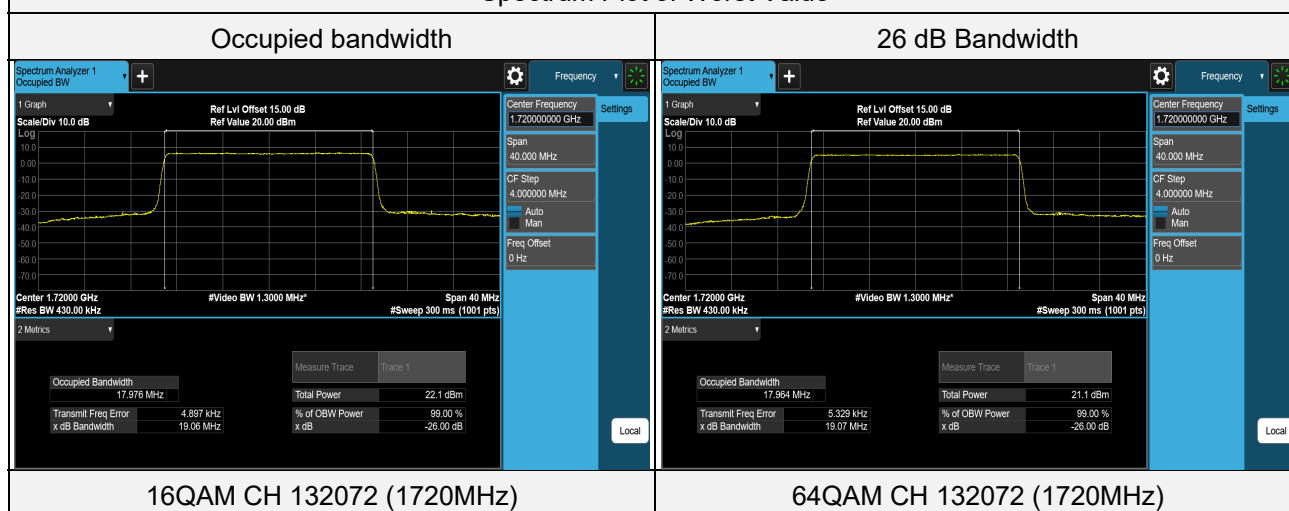

LTE Band 71 (Channel Bandwidth 5MHz)

| Test Condition | Channel | Frequency (MHz) | Occupied bandwidth (MHz) | 26 dB Bandwidth (MHz) |
|----------------|---------|-----------------|--------------------------|-----------------------|
| QPSK | 133147 | 665.5 | 4.4832 | 4.825 |
| QPSK | 133297 | 680.5 | 4.4891 | 4.857 |
| QPSK | 133447 | 695.5 | 4.4944 | 4.864 |
| 16QAM | 133147 | 665.5 | 4.4801 | 4.834 |
| 16QAM | 133297 | 680.5 | 4.4870 | 4.836 |
| 16QAM | 133447 | 695.5 | 4.4920 | 4.859 |
| 64QAM | 133147 | 665.5 | 4.4825 | 4.803 |
| 64QAM | 133297 | 680.5 | 4.4926 | 4.852 |
| 64QAM | 133447 | 695.5 | 4.4987 | 4.850 |

NOTE: For the test plots please refer to the below pages.

Spectrum Plot of Worst Value

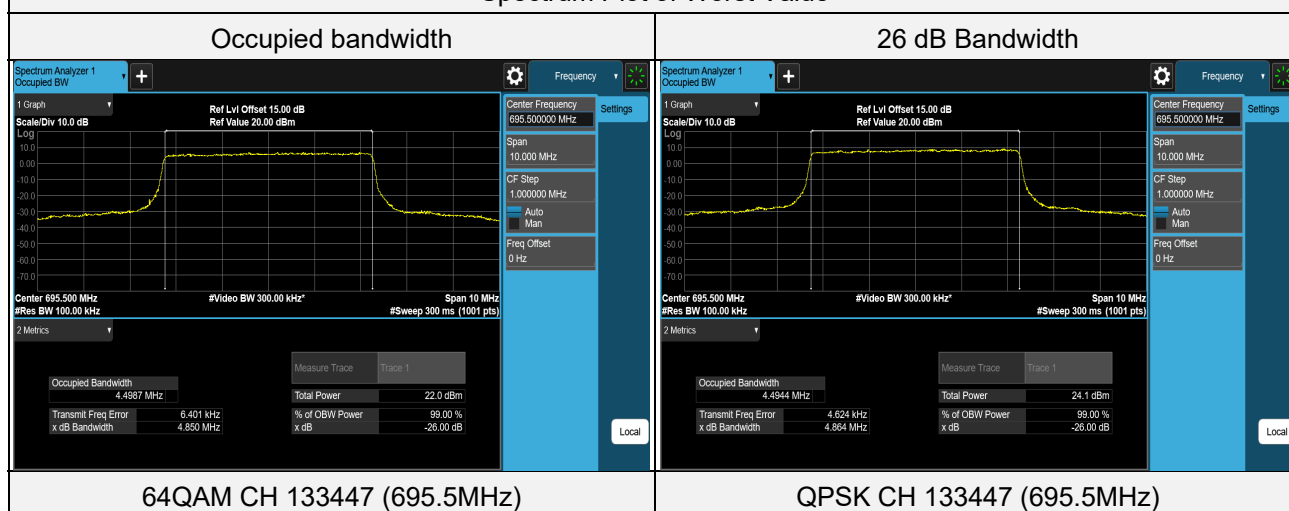

LTE Band 71 (Channel Bandwidth 10MHz)

| Test Condition | Channel | Frequency (MHz) | Occupied bandwidth (MHz) | 26 dB Bandwidth (MHz) |
|----------------|---------|-----------------|--------------------------|-----------------------|
| QPSK | 133172 | 668 | 8.9225 | 9.506 |
| QPSK | 133297 | 680.5 | 8.9446 | 9.496 |
| QPSK | 133422 | 693 | 8.9948 | 9.554 |
| 16QAM | 133172 | 668 | 8.9171 | 9.499 |
| 16QAM | 133297 | 680.5 | 8.9446 | 9.505 |
| 16QAM | 133422 | 693 | 8.9945 | 9.540 |
| 64QAM | 133172 | 668 | 8.9164 | 9.500 |
| 64QAM | 133297 | 680.5 | 8.9454 | 9.511 |
| 64QAM | 133422 | 693 | 8.9969 | 9.567 |

NOTE: For the test plots please refer to the below pages.

Spectrum Plot of Worst Value

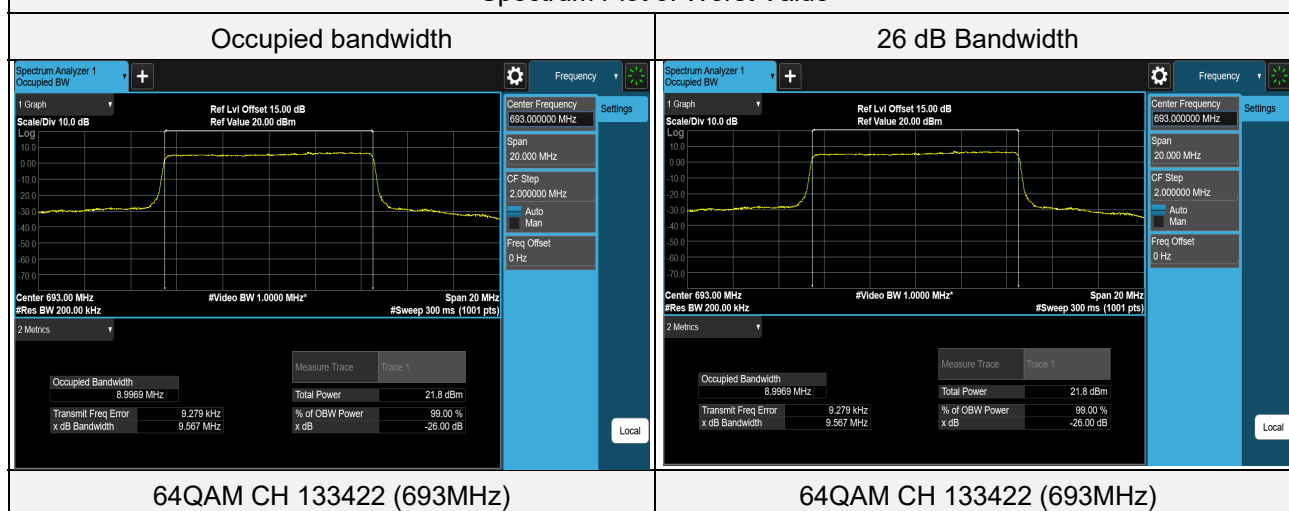

LTE Band 71 (Channel Bandwidth 15MHz)

| Test Condition | Channel | Frequency (MHz) | Occupied bandwidth (MHz) | 26 dB Bandwidth (MHz) |
|----------------|---------|-----------------|--------------------------|-----------------------|
| QPSK | 133197 | 670.5 | 13.4405 | 14.245 |
| QPSK | 133297 | 680.5 | 13.3878 | 14.203 |
| QPSK | 133397 | 690.5 | 13.5255 | 14.310 |
| 16QAM | 133197 | 670.5 | 13.4301 | 14.250 |
| 16QAM | 133297 | 680.5 | 13.3744 | 14.218 |
| 16QAM | 133397 | 690.5 | 13.5149 | 14.311 |
| 64QAM | 133197 | 670.5 | 13.4249 | 14.257 |
| 64QAM | 133297 | 680.5 | 13.3691 | 14.203 |
| 64QAM | 133397 | 690.5 | 13.5124 | 14.345 |

NOTE: For the test plots please refer to the below pages.

Spectrum Plot of Worst Value

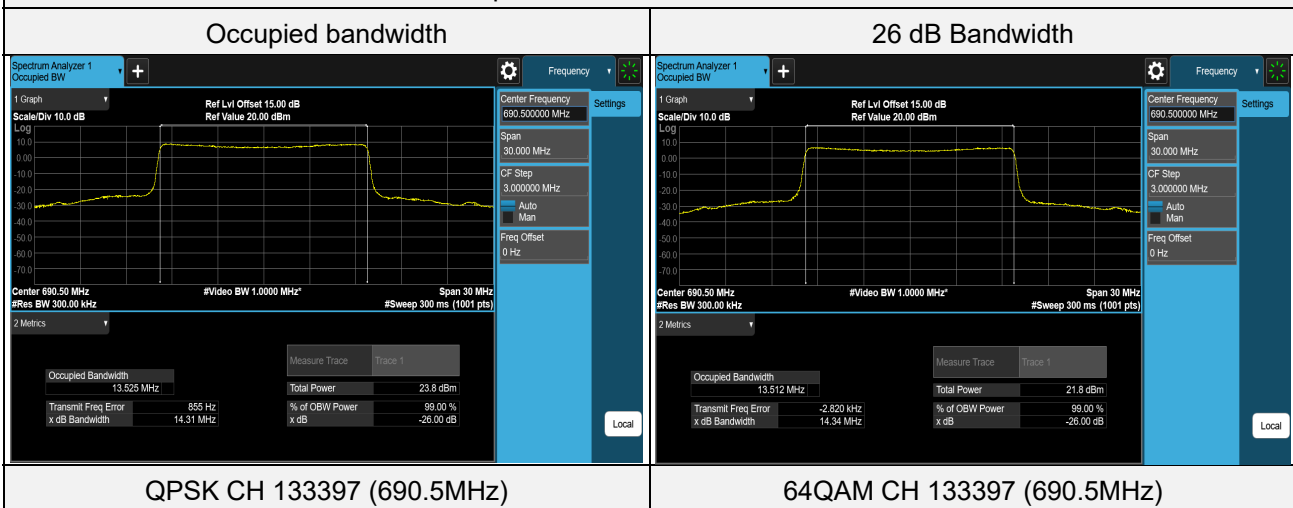

LTE Band 71 (Channel Bandwidth 20MHz)

| Test Condition | Channel | Frequency (MHz) | Occupied bandwidth (MHz) | 26 dB Bandwidth (MHz) |
|----------------|---------|-----------------|--------------------------|-----------------------|
| QPSK | 133222 | 673 | 17.9336 | 19.015 |
| QPSK | 133297 | 680.5 | 17.8617 | 18.978 |
| QPSK | 133372 | 688 | 18.0109 | 19.060 |
| 16QAM | 133222 | 673 | 17.9473 | 19.010 |
| 16QAM | 133297 | 680.5 | 17.8743 | 18.969 |
| 16QAM | 133372 | 688 | 18.0156 | 19.041 |
| 64QAM | 133222 | 673 | 17.9301 | 19.003 |
| 64QAM | 133297 | 680.5 | 17.8696 | 18.986 |
| 64QAM | 133372 | 688 | 18.0021 | 19.048 |

NOTE: For the test plots please refer to the below pages.

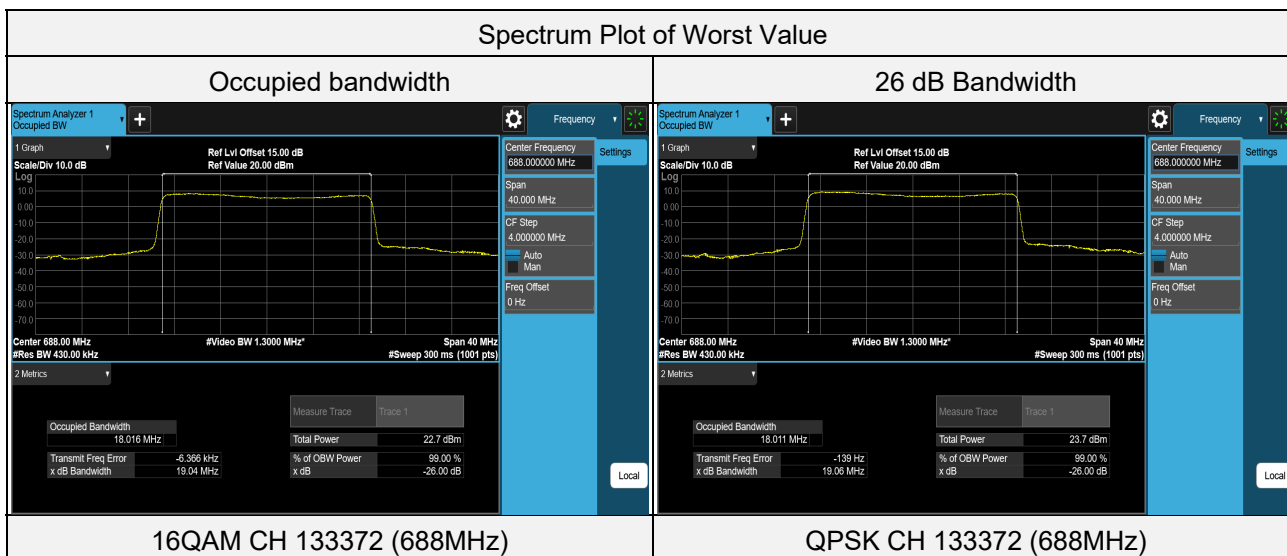

4.5 Channel Edge / Out-of-Band Emissions Measurement

4.5.1 Limits of Band Edge / Out-of-Band Emissions Measurement

For LTE Band 4, LTE Band 66:

According to FCC 27.53(h) for operations in the 1695-1710MHz, 1710-1755MHz, 1755-1780 MHz, 1915-1920MHz, 1995-2000 MHz, 2000-2020MHz, 2110-2155MHz, 2155-2180 MHz, and 2180-2200 bands, the power of any emission outside a licensee's frequency block shall be attenuated below the transmitter power (P) in watts by at least $43 + 10 \log (P)$ dB.

For LTE Band 7:

According to FCC 27.53(m)(4) specified that power of any emission outside of the channel edge must be attenuated below the transmitting power (P) by a factor shall be not less than $40 + 10 \log (P)$ dB on all frequencies between the channel edge and 5 megahertz from the channel edge, $43 + 10 \log (P)$ dB on all frequencies between 5 megahertz and X megahertz from the channel edge, and $55 + 10 \log (P)$ dB on all frequencies more than X megahertz from the channel edge, where X is the greater of 6 megahertz or the actual emission bandwidth. In addition, the attenuation factor shall not be less that $43 + 10 \log (P)$ dB on all frequencies between 2490.5MHz and 2496 MHz and $55 + 10 \log (P)$ dB at or below 2490.5MHz. In the 1 MHz bands immediately outside and adjacent to the frequency block a resolution bandwidth of at least two percent may be employed, except when the 1 megahertz band is 2495-2496 MHz, in which case a resolution bandwidth of at least one percent may be employed.

For LTE Band 12, LTE Band 17, LTE Band 71:

According to FCC 27.53(g) for operations in the 600 MHz band and the 698-746 MHz band, the power of any emission outside a licensee's frequency band(s) of operation shall be attenuated below the transmitter power (P) within the licensed band(s) of operation, measured in watts, by at least $43 + 10 \log (P)$ dB. Compliance with this provision is based on the use of measurement instrumentation employing a resolution bandwidth of 100 kilohertz or greater.

4.5.2 Test Setup

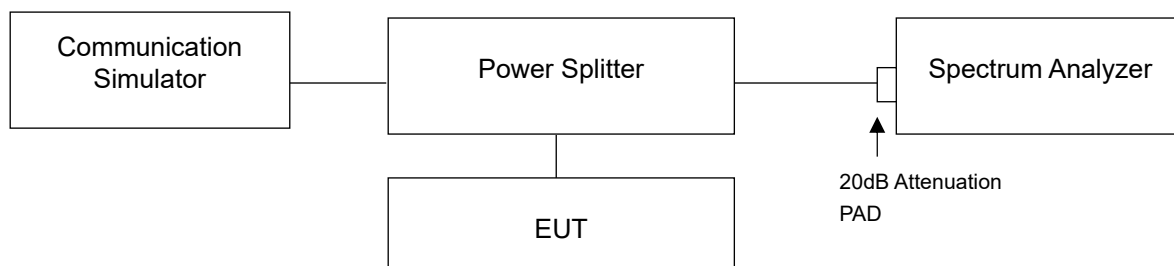

4.5.3 Test Procedures

- a. The EUT was set up for the rated peak power. The power was measured with Spectrum Analyzer. Band edge measurements were done at 2 channels: low and high operational frequency range.
- b. The center frequency of spectrum is the band edge frequency and span is 1MHz. RB of the spectrum is 15kHz and VB of the spectrum is 51kHz (LTE Channel Bandwidth 1.4MHz).
- c. The center frequency of spectrum is the band edge frequency and span is 1MHz. RB of the spectrum is 30kHz and VB of the spectrum is 100kHz (LTE Channel Bandwidth 3MHz).
- d. The center frequency of spectrum is the band edge frequency and span is 1MHz. RB of the spectrum is 51kHz and VB of the spectrum is 160kHz (LTE Channel Bandwidth 5MHz).
- e. The center frequency of spectrum is the band edge frequency and span is 1MHz. RB of the spectrum is 100kHz and VB of the spectrum is 300kHz (LTE Channel Bandwidth 10MHz).
- f. The center frequency of spectrum is the band edge frequency and span is 1MHz. RB of the spectrum is 150kHz and VB of the spectrum is 470kHz (LTE Channel Bandwidth 15MHz).
- g. The center frequency of spectrum is the band edge frequency and span is 1MHz. RB of the spectrum is 200kHz and VB of the spectrum is 1MHz (LTE Channel Bandwidth 20MHz).
- h. Except LTE Band 12 measurement procedure refer 27.53(g).
 - i. LTE Band 7 measurement, for 5 MHz and 10 MHz channel BW mode, extend the 1% range from 1M to 2M above and below the channel edge and then reduce the limit further by $10 \log (1000/100) = 10\text{dB}$ (i.e. total $-10 + -10 = -20\text{dB}$) to compensate for the integration from 100k to 1M.
- j. Record the max trace plot into the test report.

4.5.4 Test Results

Band Edge

LTE Band 4 (Channel Bandwidth 1.4MHz)

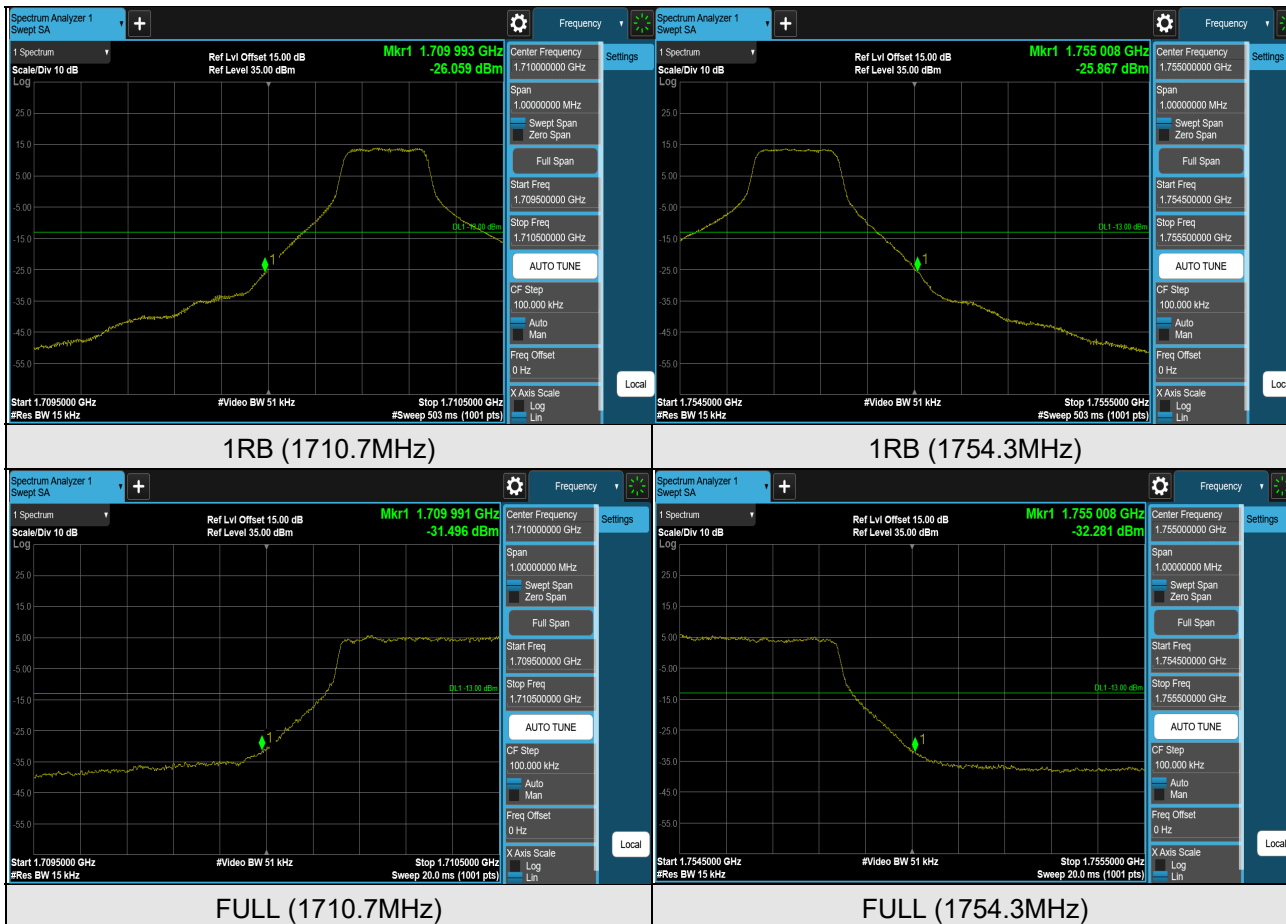

LTE Band 4 (Channel Bandwidth 3MHz)

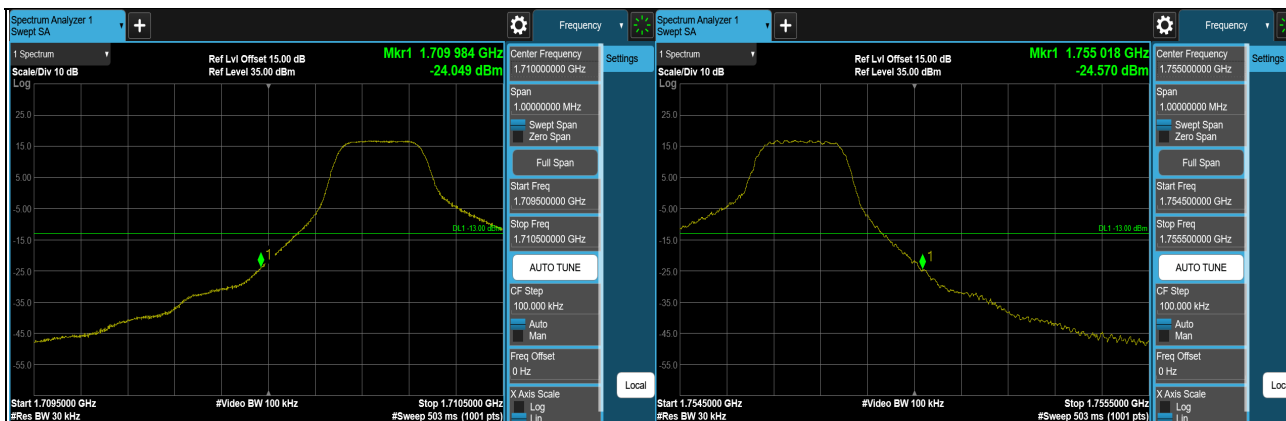

1RB (1711.5MHz)

1RB (1753.5MHz)

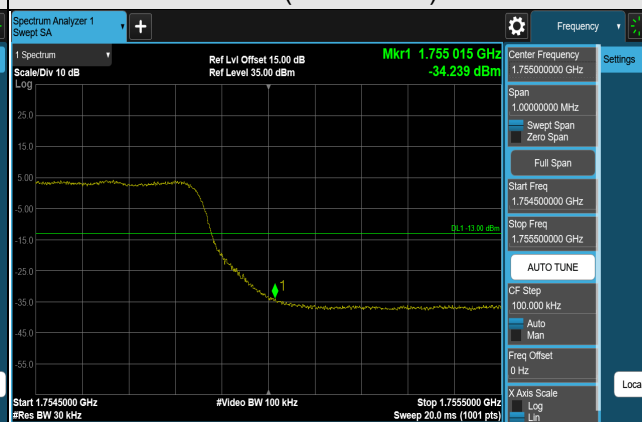
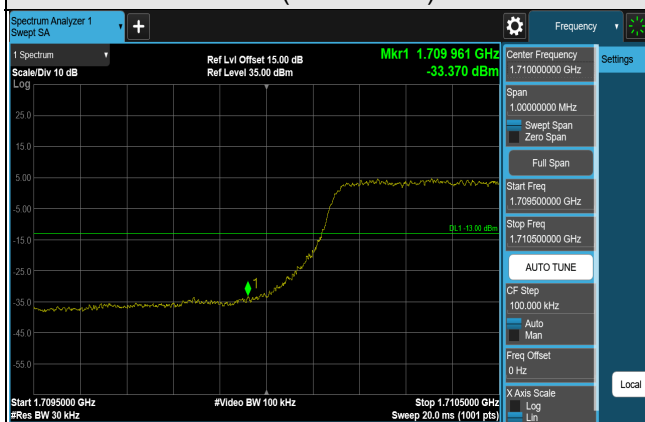

FULL (1711.5MHz)

FULL (1753.5MHz)

LTE Band 4 (Channel Bandwidth 5MHz)

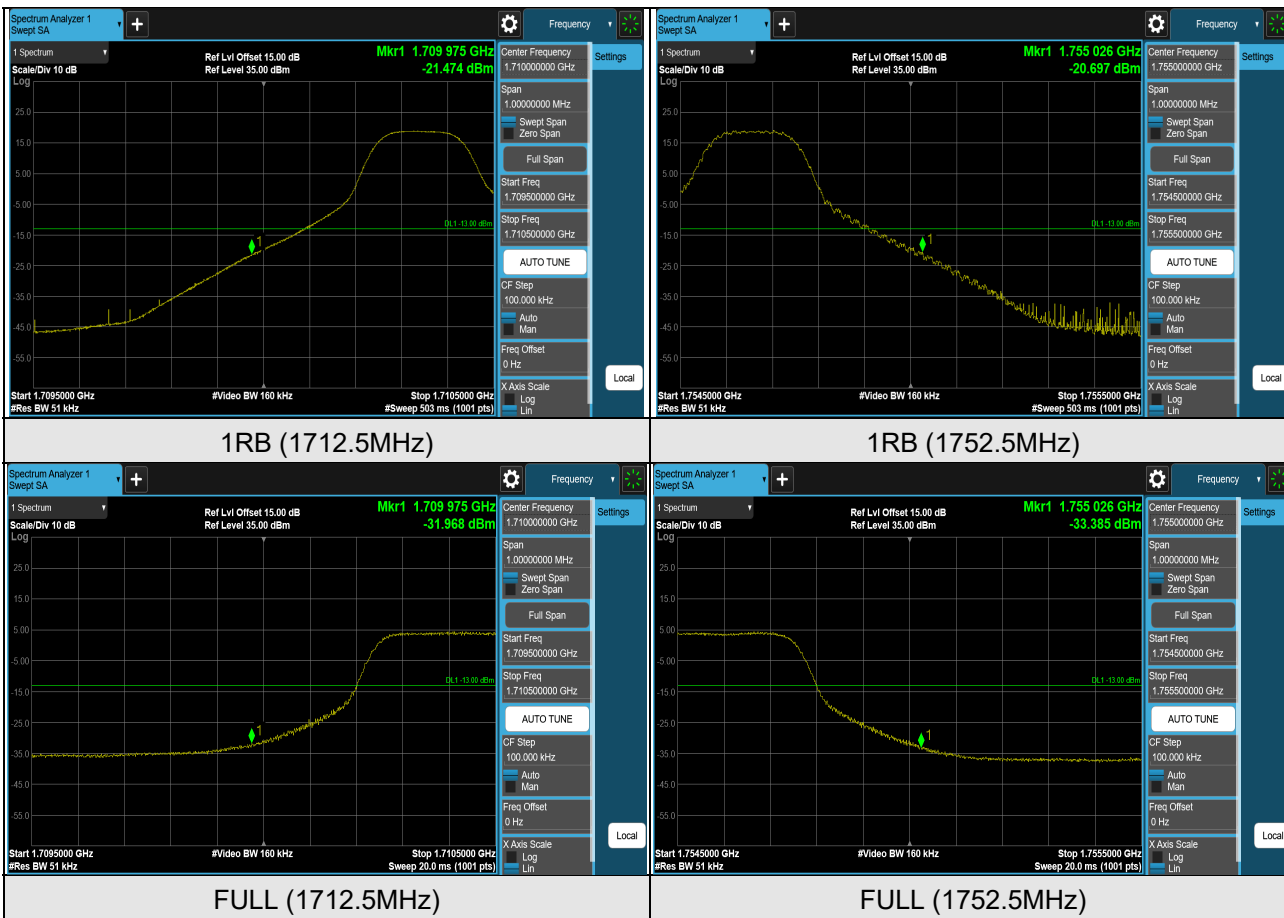

LTE Band 4 (Channel Bandwidth 10MHz)

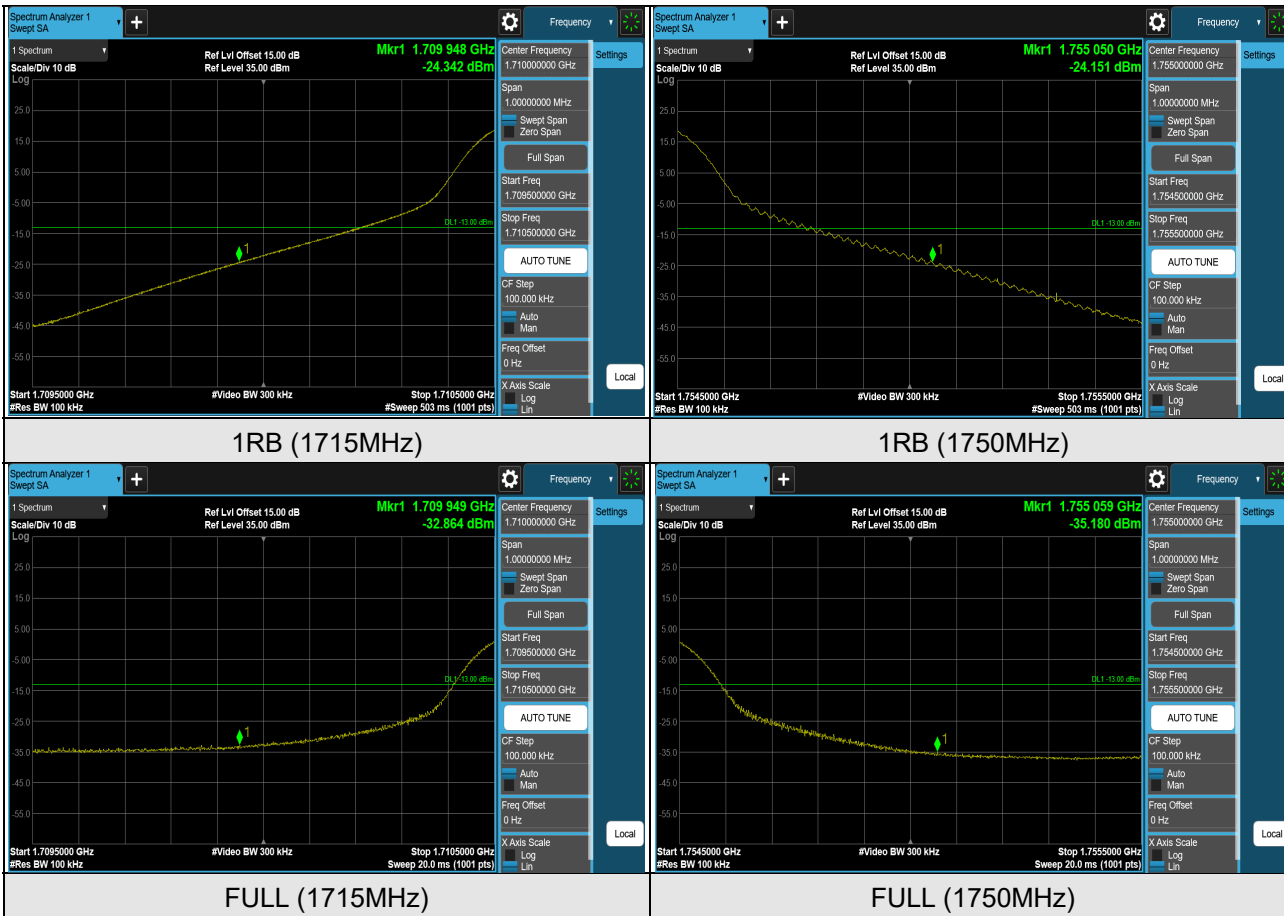

LTE Band 4 (Channel Bandwidth 15MHz)

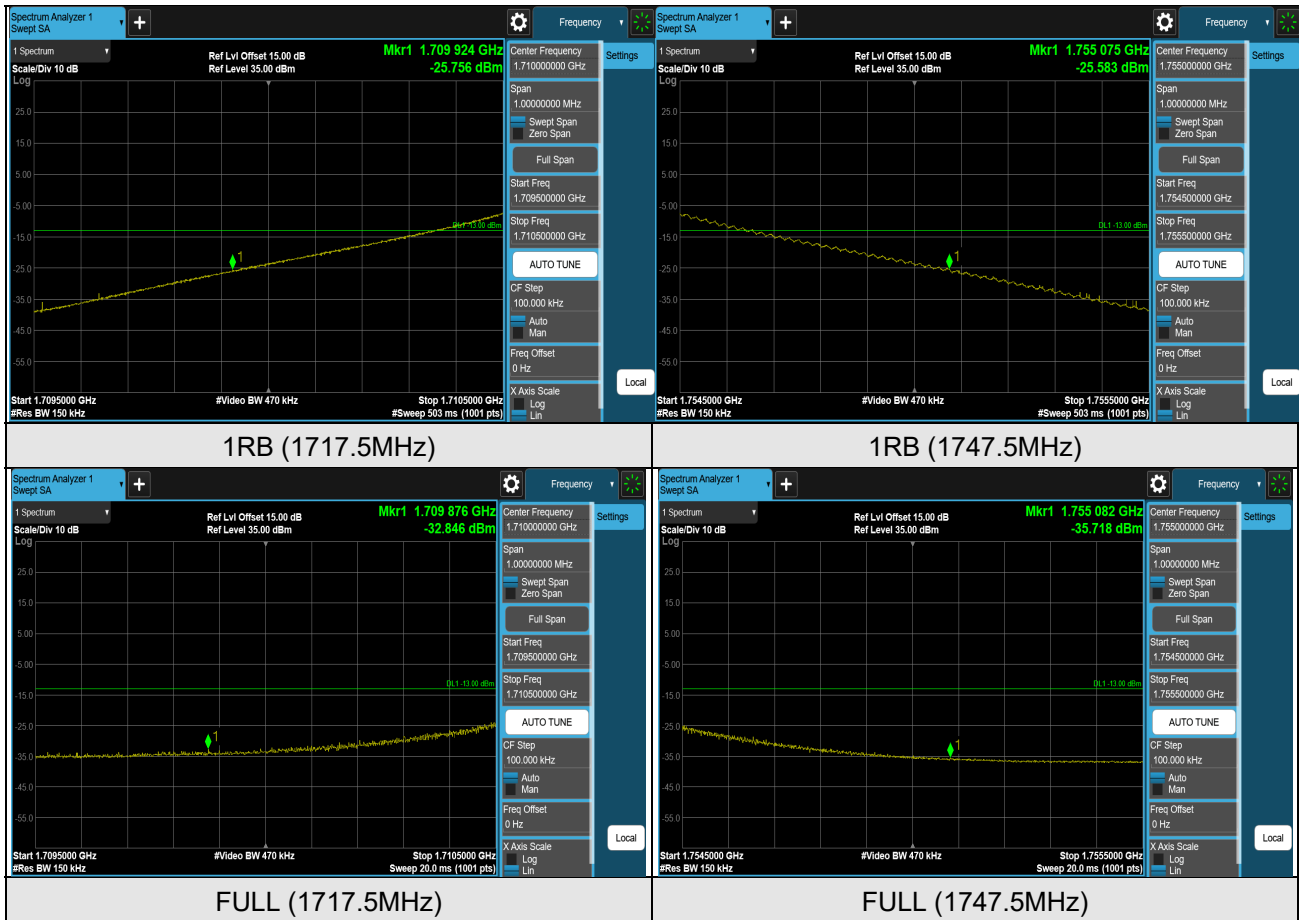

LTE Band 4 (Channel Bandwidth 20MHz)

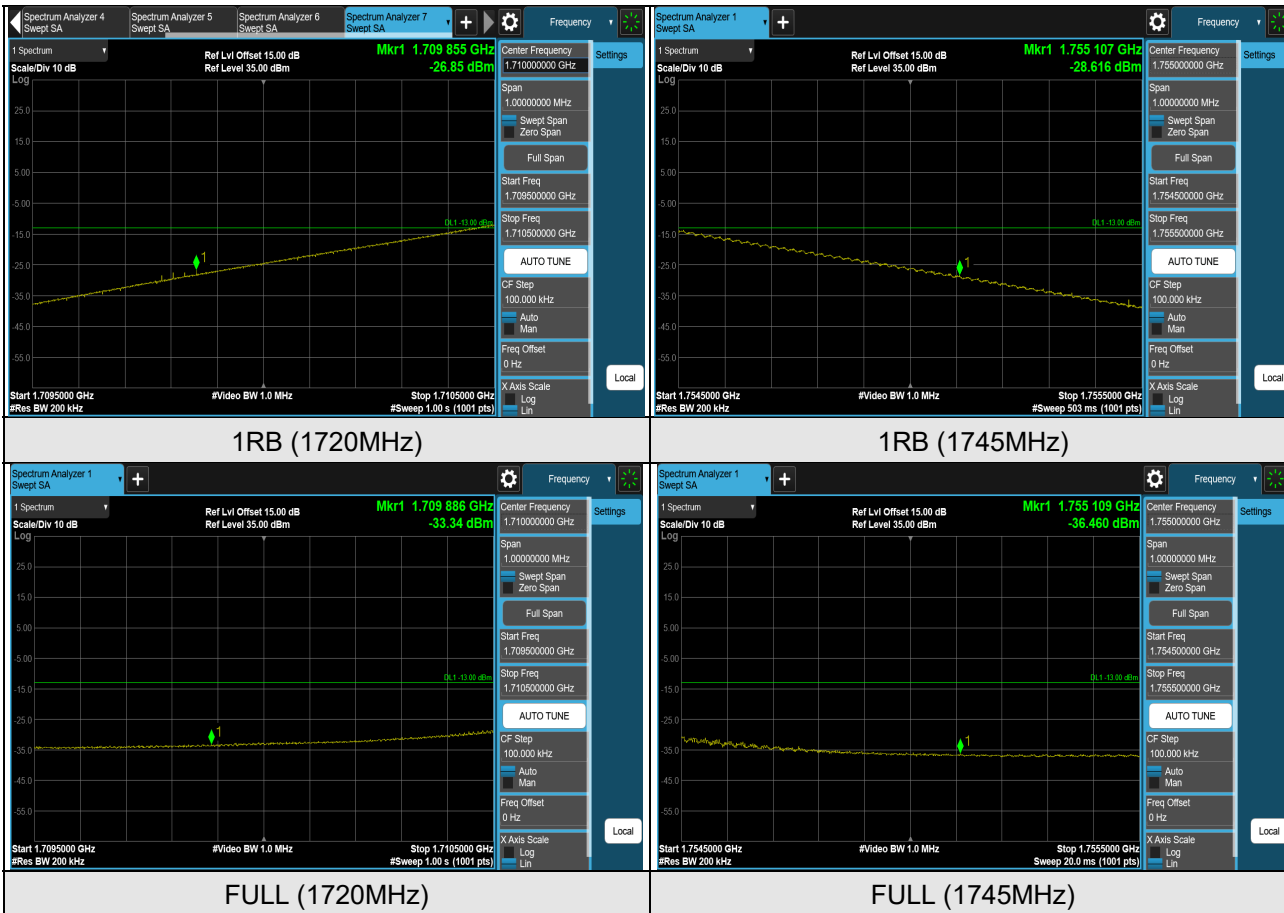

LTE Band 7 (Channel Bandwidth 5MHz)

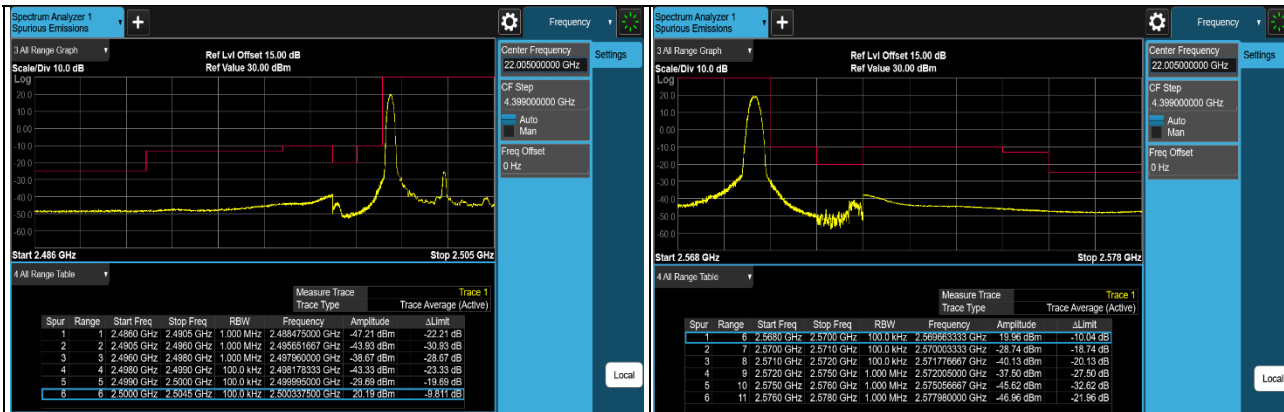

1RB (2502.5MHz)

1RB (2567.5MHz)

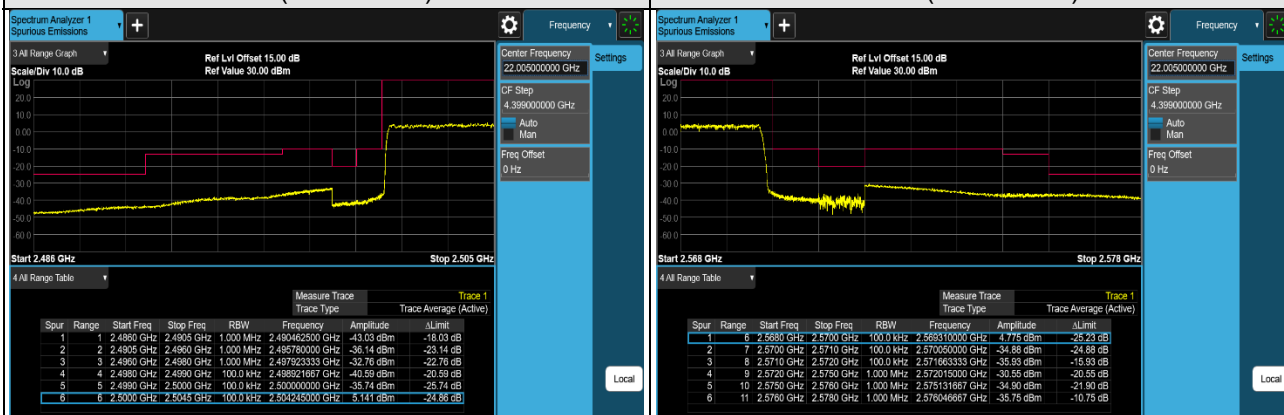

FULL (2502.5MHz)

FULL (2567.5MHz)

LTE Band 7 (Channel Bandwidth 10MHz)

