

FCC Test Report (PART 27)

Report No.: RF190819E05-2

FCC ID: NKRM18QF

Test Model: M18QF

Series Model: M18QA, M14QF, M14QA

Received Date: Aug. 19, 2019

Test Date: Aug. 30 to Sep. 06, 2019

Issued Date: Oct. 18, 2019

Applicant: Wistron NeWeb Corporation

Address: 20 Park Ave. II, Hsinchu Science Park, Hsinchu 308, Taiwan

Issued By: Bureau Veritas Consumer Products Services (H.K.) Ltd., Taoyuan Branch
Hsin Chu Laboratory

Lab Address: E-2, No.1, Li Hsin 1st Road, Hsinchu Science Park, Hsinchu City 300,
Taiwan

Test Location: E-2, No.1, Li Hsin 1st Road, Hsinchu Science Park, Hsinchu City 300,
Taiwan

**FCC Registration /
Designation Number:** 723255 / TW2022



This report is for your exclusive use. Any copying or replication of this report to or for any other person or entity, or use of our name or trademark, is permitted only with our prior written permission. This report sets forth our findings solely with respect to the test samples identified herein. The results set forth in this report are not indicative or representative of the quality or characteristics of the lot from which a test sample was taken or any similar or identical product unless specifically and expressly noted. Our report includes all of the tests requested by you and the results thereof based upon the information that you provided to us. You have 60 days from date of issuance of this report to notify us of any material error or omission caused by our negligence, provided, however, that such notice shall be in writing and shall specifically address the issue you wish to raise. A failure to raise such issue within the prescribed time shall constitute your unqualified acceptance of the completeness of this report, the tests conducted and the correctness of the report contents. Unless specific mention, the uncertainty of measurement has been explicitly taken into account to declare the compliance or non-compliance to the specification. The report must not be used by the client to claim product certification, approval, or endorsement by TAF or any government agencies.

Table of Contents

Release Control Record	4
1 Certificate of Conformity	5
2 Summary of Test Results	6
2.1 Measurement Uncertainty	6
2.2 Test Site and Instruments	7
3 General Information	9
3.1 General Description of EUT	9
3.2 Configuration of System under Test	12
3.2.1 Description of Support Units	13
3.3 Test Mode Applicability and Tested Channel Detail	14
3.4 EUT Operating Conditions	18
3.5 General Description of Applied Standards	18
4 Test Types and Results	19
4.1 Output Power Measurement	19
4.1.1 Limits of Output Power Measurement	19
4.1.2 Test Procedures	19
4.1.3 Test Setup	20
4.1.4 Test Results	21
4.2 Modulation characteristics Measurement	30
4.2.1 Limits of Modulation characteristics	30
4.2.2 Test Procedure	30
4.2.3 Test Setup	30
4.2.4 Test Results	31
4.3 Frequency Stability Measurement	32
4.3.1 Limits of Frequency Stability Measurement	32
4.3.2 Test Procedure	32
4.3.3 Test Setup	32
4.3.4 Test Results	33
4.4 Emission Bandwidth Measurement	36
4.4.1 Limits of Emission Bandwidth Measurement	36
4.4.2 Test Procedure	36
4.4.3 Test Setup	36
4.4.4 Test Results (-26dB Bandwidth)	37
4.4.5 Test Results (Occupied Bandwidth)	41
4.5 Channel Edge Measurement	45
4.5.1 Limits of Channel Edge Measurement	45
4.5.2 Test Setup	46
4.5.3 Test Procedures	46
4.5.4 Test Results	47
4.6 Peak to Average Ratio	59
4.6.1 Limits of Peak to Average Ratio Measurement	59
4.6.2 Test Setup	59
4.6.3 Test Procedures	59
4.6.4 Test Results	60
4.7 Conducted Spurious Emissions	64
4.7.1 Limits of Conducted Spurious Emissions Measurement	64
4.7.2 Test Setup	64
4.7.3 Test Procedure	64
4.7.5 Test Results	65
4.8 Radiated Emission Measurement	89
4.8.1 Limits of Radiated Emission Measurement	89
4.8.2 Test Procedure	90
4.8.3 Deviation from Test Standard	90

4.8.4 Test Setup.....	91
4.8.5 Test Results	92
5 Pictures of Test Arrangements.....	160
Appendix – Information of the Testing Laboratories	161

Release Control Record

Issue No.	Description	Date Issued
RF190819E05-2	Original release.	Oct. 18, 2019

1 Certificate of Conformity

Product: M2M DATA MODULE

Brand: Wistron NeWeb Corporation

Test Model: M18QF

Series Model: M18QA, M14QF, M14QA

Sample Status: ENGINEERING SAMPLE

Applicant: Wistron NeWeb Corporation

Test Date: Aug. 30 to Sep. 06, 2019

Standards: FCC Part 27, Subpart H / L / F
FCC Part 2

The above equipment has been tested by **Bureau Veritas Consumer Products Services (H.K.) Ltd., Taoyuan Branch**, and found compliance with the requirement of the above standards. The test record, data evaluation & Equipment Under Test (EUT) configurations represented herein are true and accurate accounts of the measurements of the sample's EMC characteristics under the conditions specified in this report.

Prepared by :  , **Date:** Oct. 18, 2019
Claire Kuan / Specialist

Approved by :  , **Date:** Oct. 18, 2019
Clark Lin / Technical Manager

2 Summary of Test Results

Applied Standard: FCC Part 27 & Part 2			
FCC Clause	Test Item	Result	Remarks
2.1046 27.50	Radiated Power	PASS	Meet the requirement of limit.
2.1047	Modulation characteristics	PASS	Meet the requirement
2.1055 27.54	Frequency Stability Stay with the authorized bands of operation	PASS	Meet the requirement of limit.
2.1049 27.53	Occupied Bandwidth	PASS	Meet the requirement of limit.
27.53	Band Edge Measurements	PASS	Meet the requirement of limit.
---	Peak To Average Ratio	PASS	Meet the requirement of limit.
2.1051 27.53	Conducted Spurious Emissions	PASS	Meet the requirement of limit.
2.1053 27.53	Radiated Spurious Emissions	PASS	Meet the requirement of limit. Minimum passing margin is -14.44dB at 1564MHz.

Note:

Determining compliance based on the results of the compliance measurement, not taking into account measurement instrumentation uncertainty

2.1 Measurement Uncertainty

Where relevant, the following measurement uncertainty levels have been estimated for tests performed on the EUT as specified in CISPR 16-4-2:

Measurement	Frequency	Expanded Uncertainty (k=2) (\pm)
Radiated Emissions up to 1 GHz	9kHz ~ 30MHz	3.0 dB
	30MHz ~ 1GHz	4.9 dB
Radiated Emissions above 1 GHz	1GHz ~ 6GHz	5.1 dB
	6GHz ~ 18GHz	4.9 dB
	18GHz ~ 40GHz	5.2 dB

2.2 Test Site and Instruments

For radiated spurious emissions test:

DESCRIPTION & MANUFACTURER	MODEL NO.	SERIAL NO.	CALIBRATED DATE	CALIBRATED UNTIL
Test Receiver Keysight	N9038A	MY54450088	July 03, 2019	July 02, 2020
Pre-Amplifier EMCI	EMC001340	980142	May 30, 2019	May 29, 2020
Loop Antenna Electro-Metrics	EM-6879	264	Jan. 22, 2019	Jan. 21, 2020
RF Cable	NA	LOOPCAB-001	Jan. 14, 2019	Jan. 13, 2020
RF Cable	NA	LOOPCAB-002	Jan. 14, 2019	Jan. 13, 2020
Pre-Amplifier Mini-Circuits	ZFL-1000VH2B	AMP-ZFL-01	Oct. 30, 2018	Oct. 29, 2019
Trilog Broadband Antenna SCHWARZBECK	VULB 9168	9168-406	Nov. 22, 2018	Nov. 21, 2019
RF Cable	8D	966-4-1	Mar. 19, 2019	Mar. 18, 2020
RF Cable	8D	966-4-2	Mar. 19, 2019	Mar. 18, 2020
RF Cable	8D	966-4-3	Mar. 19, 2019	Mar. 18, 2020
Fixed attenuator Mini-Circuits	UNAT-5+	PAD-3m-4-01	Sep. 27, 2018	Sep. 26, 2019
Horn_Antenna SCHWARZBECK	BBHA 9120D	9120D-783	Nov. 25, 2018	Nov. 24, 2019
Pre-Amplifier EMCI	EMC12630SE	980385	Aug. 15, 2019	Aug. 14, 2020
RF Cable	EMC104-SM-SM-1200	160923	Jan. 28, 2019	Jan. 27, 2020
RF Cable	104 RF cable	131215	Jan. 10, 2019	Jan. 09, 2020
RF Cable	EMC104-SM-SM-6000	180418	May 03, 2019	May 02, 2020
Pre-Amplifier EMCI	EMC184045SE	980387	Jan. 28, 2019	Jan. 27, 2020
Horn_Antenna SCHWARZBECK	BBHA 9170	BBHA9170519	Nov. 25, 2018	Nov. 24, 2019
RF Cable	EMC102-KM-KM-1200	160924	Jan. 28, 2019	Jan. 27, 2020
RF Cable	EMC102-KM-KM-1200	160925	Jan. 28, 2019	Jan. 27, 2020
Software	ADT_Radiated_V8.7.08	NA	NA	NA
Boresight Antenna Tower & Turn Table Max-Full	MF-7802BS	MF780208530	NA	NA

Note:

1. The calibration interval of the above test instruments is 12 months and the calibrations are traceable to NML/ROC and NIST/USA.
2. The test was performed in 966 Chamber No. 4.
3. Loop antenna was used for all emissions below 30 MHz.
4. Tested Date: Aug. 30 to Sep. 06, 2019

For other test items:

DESCRIPTION & MANUFACTURER	MODEL NO.	SERIAL NO.	CALIBRATED DATE	CALIBRATED UNTIL
Spectrum Analyzer R&S	FSV40	100964	June 04, 2019	June 03, 2020
Spectrum Analyzer Agilent	E4446A	MY48250253	July 24, 2019	July 23, 2020
Power meter Anritsu	ML2495A	1014008	May 13, 2019	May 12, 2020
Power sensor Anritsu	MA2411B	0917122	May 13, 2019	May 12, 2020
Fixed Attenuator Mini-Circuits	MDCS18N-10	MDCS18N-10-01	Apr. 15, 2019	Apr. 14, 2020
AC Power Source Extech Electronics	6205	1440452	NA	NA
DC Power Supply Topward	6603D	795558	NA	NA
Temperature & Humidity Chamber Giant Force	GTH-150-40-SP-AR	MAA0812-008	Jan. 09, 2019	Jan. 08, 2020
True RMS Clamp Meter FLUKE	325	31130711WS	May 21, 2019	May 20, 2020
ESG Vector signal generator Agilent	E4438C	MY45094468/005 506 602 UK6 UNJ	Nov. 19, 2018	Nov. 18, 2019
Mech Switch Absorptive Mini-Circuits	MSP4TA-18+	0140	Feb. 11, 2019	Feb. 10, 2020
FXD ATTEN Mini-Circuits	BW-S3W2+	MN71981	Feb. 11, 2019	Feb. 10, 2020
Software	ADT_RF Test Software V6.6.5.4	NA	NA	NA
LTE Wireless Communication Test Set Keysight	E7515A	MY55340229	May 29, 2019	May 28, 2020

- NOTE:**
1. The test was performed in Oven room 2.
 2. The calibration interval of the above test instruments is 12 months and the calibrations are traceable to NML/ROC and NIST/USA.
 3. Tested Date: Sep. 03 to 13, 2019

3 General Information

3.1 General Description of EUT

Product	M2M DATA MODULE	
Brand	Wistron NeWeb Corporation	
Test Model	M18QF	
Series Model	M18QA, M14QF, M14QA	
Status of EUT	ENGINEERING SAMPLE	
Power Supply Rating	DC 3.8V from host equipment	
Modulation Type	LTE	QPSK, 16QAM
Operating Frequency	LTE Band 4	1710.7 ~ 1754.3 MHz
	LTE Band 12	699.7 ~ 715.3 MHz
	LTE Band 13	779.5 ~ 784.5 MHz
Max. EIRP Power	LTE Band 4 (Channel Bandwidth 1.4MHz)	24.42dBm
	LTE Band 4 (Channel Bandwidth 3MHz)	24.59dBm
	LTE Band 4 (Channel Bandwidth 5MHz)	24.38dBm
	LTE Band 4 (Channel Bandwidth 10MHz)	24.60dBm
	LTE Band 4 (Channel Bandwidth 15MHz)	24.49dBm
	LTE Band 4 (Channel Bandwidth 20MHz)	24.64dBm
Max. ERP Power	LTE Band 12 (Channel Bandwidth 1.4MHz)	23.61dBm
	LTE Band 12 (Channel Bandwidth 3MHz)	23.67dBm
	LTE Band 12 (Channel Bandwidth 5MHz)	23.63dBm
	LTE Band 12 (Channel Bandwidth 10MHz)	23.83dBm
	LTE Band 13 (Channel Bandwidth 5MHz)	24.04dBm
	LTE Band 13 (Channel Bandwidth 10MHz)	23.68dBm

Emission Designator	LTE Band 4 (Channel Bandwidth 1.4MHz)	QPSK: 1M09G7D 16QAM: 1M10D7W	
	LTE Band 4 (Channel Bandwidth 3MHz)	QPSK: 2M70G7D 16QAM: 2M69D7W	
	LTE Band 4 (Channel Bandwidth 5MHz)	QPSK: 4M51G7D 16QAM: 4M52D7W	
	LTE Band 4 (Channel Bandwidth 10MHz)	QPSK: 9M00G7D 16QAM: 9M00D7W	
	LTE Band 4 (Channel Bandwidth 15MHz)	QPSK: 13M5G7D 16QAM: 13M4D7W	
	LTE Band 4 (Channel Bandwidth 20MHz)	QPSK: 18M0G7D 16QAM: 17M9D7W	
	LTE Band 12 (Channel Bandwidth 1.4MHz)	QPSK: 1M09G7D 16QAM: 1M10D7W	
	LTE Band 12 (Channel Bandwidth 3MHz)	QPSK: 2M70G7D 16QAM: 2M69D7W	
	LTE Band 12 (Channel Bandwidth 5MHz)	QPSK: 4M51G7D 16QAM: 4M51D7W	
	LTE Band 12 (Channel Bandwidth 10MHz)	QPSK: 9M02G7D 16QAM: 9M00D7W	
	LTE Band 13 (Channel Bandwidth 5MHz)	QPSK: 4M52G7D 16QAM: 4M51D7W	
	LTE Band 13 (Channel Bandwidth 10MHz)	QPSK: 8M96G7D 16QAM: 8M94D7W	
	Antenna Type	Refer to Note	
	Antenna Connector	Refer to Note	
Accessory Device	NA		
Data Cable Supplied	NA		

Note:

1. All models are listed as below.

No.	Model Name	Support Spec.	
		LTE	GPS
1	M18QF	CAT4, LTE B2/4/5/12/13, WCDMA B2/5	Yes
2	M18QA	CAT4, LTE B2/4/5/12/14, WCDMA B2/5	No
3	M14QF	CAT1, LTE B2/4/5/12/13, WCDMA B2/5	Yes
4	M14QA	CAT1, LTE B2/4/5/12/14, WCDMA B2/5	No

Note: From the above models, model: M18QF was selected as representative model for the test and its data was recorded in this report.

- M18QF (LTE B2/4/5/12/13; 3G: B2/5) and M18QA (LTE B2/4/5/12/14; 3G: B2/5) are with same layout and the only difference is LTE supporting bands through software control.
- M18QA has only component change for B13/B14 of passive filter. For more details please refer to operation description exhibit.

2. The antennas provided to the EUT, please refer to the following table:

For GPS							
Antenna No.	Brand	Model	Antenna Net Gain (dBi)	Frequency Range (MHz)	Antenna Type	Connector Type	
GPS	Master	98619ZSAX029	2.24	1559~1606	Dipole	SMA	
For WWAN							
Antenna No.	RF Chain No.	Brand	Model	Antenna Net Gain (dBi)	Frequency Range (MHz)	Antenna Type	Connector Type
1	Main	Wieson	GY115	Please refer to below table	Please refer to below table	Dipole	SMA
2	Aux	Wieson	GY115	Please refer to below table	Please refer to below table	Dipole	SMA

Antenna gain list			
Band	Freq. Range (MHz)	Gain (dBi)	
		Ant 1 (Main)	Ant 2 (Aux)
WCDMA II (B2)	1850~1910	1.56	1.56
WCDMA V (B5)	824~849	3.2	3.2
LTE Band (2)	1850~1910	1.56	1.56
LTE Band (4)	1710~1755	1.62	1.62
LTE Band (5)	824~849	3.2	3.2
LTE Band (12)	698~716	1.49	1.49
LTE Band (13)	777~787	1.66	1.66
LTE Band (14)	788~798	1.60	1.60

3. The above EUT information is declared by manufacturer and for more detailed features description, please refer to the manufacturer's specifications or User's Manual.

3.2 Configuration of System under Test

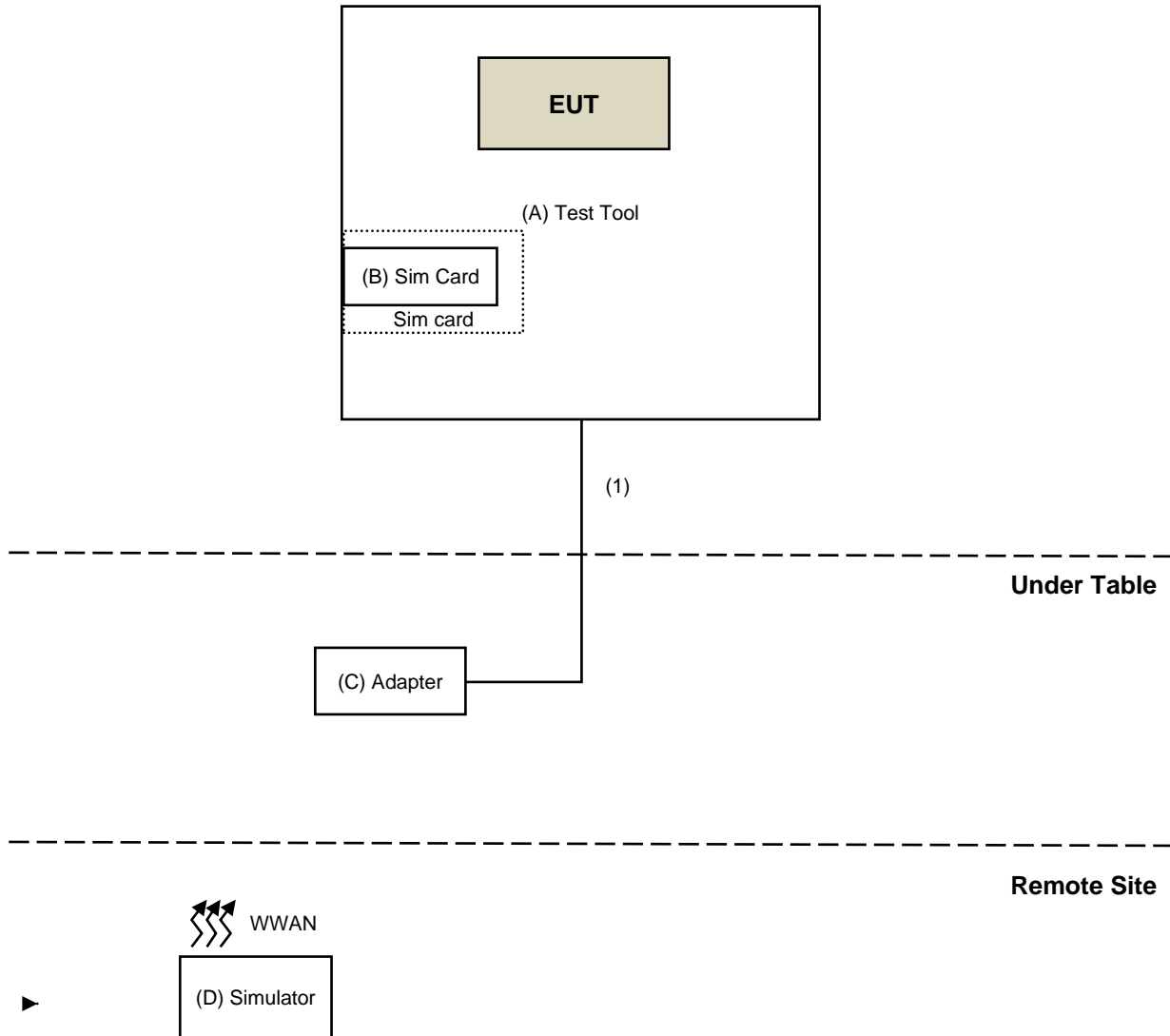

3.2.1 Description of Support Units

The EUT has been tested as an independent unit together with other necessary accessories or support units. The following support units or accessories were used to form a representative test configuration during the tests.

ID	Product	Brand	Model No.	Serial No.	FCC ID	Remarks
A.	Test Tool	NA	NA	NA	NA	Supplied by client
B.	Sim Card	R&S	CRT-Z3	NA	NA	Provided by Lab
C.	Adapter	L.E.I	MU24-Y120200-A1	NA	NA	Supplied by client
D.	Simulator	Keysight	E7515A	MY55340229	NA	Provided by Lab

Note:

1. All power cords of the above support units are non-shielded (1.8m).

ID	Descriptions	Qty.	Length (m)	Shielding (Yes/No)	Cores (Qty.)	Remarks
1.	DC Cable	1	1.5	No	0	Supplied by client

3.3 Test Mode Applicability and Tested Channel Detail

LTE Band 4

TEST ITEM	AVAILABLE CHANNEL	TESTED CHANNEL	CHANNEL BANDWIDTH	MODULATION	MODE
EIRP	19957 to 20393	19957, 20175, 20393	1.4MHz	QPSK/16QAM	1RB / 0 RB offset
	19965 to 20385	19965, 20175, 20385	3MHz	QPSK/16QAM	1RB / 0 RB offset
	19975 to 20375	19975, 20175, 20375	5MHz	QPSK/16QAM	1RB / 0 RB offset
	20000 to 20350	20000, 20175, 20350	10MHz	QPSK/16QAM	1RB / 0 RB offset
	20025 to 20325	20025, 20175, 20325	15MHz	QPSK/16QAM	1RB / 0 RB offset
	20050 to 20300	20050, 20175, 20300	20MHz	QPSK/16QAM	1RB / 0 RB offset
Frequency Stability	19957 to 20393	20175	1.4MHz	QPSK	-
	19965 to 20385	20175	3MHz	QPSK	-
	19975 to 20375	20175	5MHz	QPSK	-
	20000 to 20350	20175	10MHz	QPSK	-
	20025 to 20325	20175	15MHz	QPSK	-
	20050 to 20300	20175	20MHz	QPSK	-
Occupied Bandwidth	19957 to 20393	19957, 20175, 20393	1.4MHz	QPSK/16QAM	Full RB
	19965 to 20385	19965, 20175, 20385	3MHz	QPSK/16QAM	Full RB
	19975 to 20375	19975, 20175, 20375	5MHz	QPSK/16QAM	Full RB
	20000 to 20350	20000, 20175, 20350	10MHz	QPSK/16QAM	Full RB
	20025 to 20325	20025, 20175, 20325	15MHz	QPSK/16QAM	Full RB
	20050 to 20300	20050, 20175, 20300	20MHz	QPSK/16QAM	Full RB
Peak to Average Ratio	19957 to 20393	19957, 20175, 20393	1.4MHz	QPSK/16QAM	Full RB
	19965 to 20385	19965, 20175, 20385	3MHz	QPSK/16QAM	Full RB
	19975 to 20375	19975, 20175, 20375	5MHz	QPSK/16QAM	Full RB
	20000 to 20350	20000, 20175, 20350	10MHz	QPSK/16QAM	Full RB
	20025 to 20325	20025, 20175, 20325	15MHz	QPSK/16QAM	Full RB
	20050 to 20300	20050, 20175, 20300	20MHz	QPSK/16QAM	Full RB
Band Edge	19957 to 20393	19957	1.4MHz	QPSK	1 RB / 0 RB Offset
		20393			1 RB / 5 RB Offset
		19957, 20393			6 RB / 0 RB Offset
	19965 to 20385	19965	3MHz	QPSK	1 RB / 0 RB Offset
		20385			1 RB / 14 RB Offset
		19965, 20385			15 RB / 0 RB Offset
	19975 to 20375	19975	5MHz	QPSK	1 RB / 0 RB Offset
		20375			1 RB / 24 RB Offset
		19975, 20375			25 RB / 0 RB Offset
	20000 to 20350	20000	10MHz	QPSK	1 RB / 0 RB Offset
		20350			1 RB / 49 RB Offset
		20000, 20350			50 RB / 0 RB Offset
	20025 to 20325	20025	15MHz	QPSK	1 RB / 0 RB Offset
		20325			1 RB / 74 RB Offset
		20025, 20325			75 RB / 0 RB Offset
	20050 to 20300	20050	20MHz	QPSK	1 RB / 0 RB Offset
		20300			1 RB / 99 RB Offset
		20050, 20300			100 RB / 0 RB Offset

Conducted Emission	19957 to 20393	19957, 20175, 20393	1.4MHz	QPSK	1 RB / 0 RB Offset
	19965 to 20385	19965, 20175, 20385	3MHz	QPSK	1 RB / 0 RB Offset
	19975 to 20375	19975, 20175, 20375	5MHz	QPSK	1 RB / 0 RB Offset
	20000 to 20350	20000, 20175, 20350	10MHz	QPSK	1 RB / 0 RB Offset
	20025 to 20325	20025, 20175, 20325	15MHz	QPSK	1 RB / 0 RB Offset
	20050 to 20300	20050, 20175, 20300	20MHz	QPSK	1 RB / 0 RB Offset
Radiated Emission	19957 to 20393	19957, 20175, 20393	1.4MHz	QPSK	1 RB / 0 RB Offset
	19965 to 20385	19965, 20175, 20385	3MHz	QPSK	1 RB / 0 RB Offset
	19975 to 20375	19975, 20175, 20375	5MHz	QPSK	1 RB / 0 RB Offset
	20000 to 20350	20000, 20175, 20350	10MHz	QPSK	1 RB / 0 RB Offset
	20025 to 20325	20025, 20175, 20325	15MHz	QPSK	1 RB / 0 RB Offset
	20050 to 20300	20050, 20175, 20300	20MHz	QPSK	1 RB / 0 RB Offset

Test Condition:

Test Item	Environmental Conditions	Input Power (System)	Tested By
EIRP	25deg. C, 60%RH	120Vac, 60Hz	Jynuchun Lin
Frequency Stability	25deg. C, 60%RH	120Vac, 60Hz	Jynuchun Lin
Occupied Bandwidth	25deg. C, 60%RH	120Vac, 60Hz	Jynuchun Lin
Band Edge	25deg. C, 60%RH	120Vac, 60Hz	Jynuchun Lin
Peak to Average Ratio	25deg. C, 60%RH	120Vac, 60Hz	Jynuchun Lin
Condcudeted Emission	25deg. C, 60%RH	120Vac, 60Hz	Jynuchun Lin
Radiated Emission Below 1GHz	24deg. C, 79%RH	120Vac, 60Hz	Andy Ho
Radiated Emission Above 1GHz	25deg. C, 75%RH	120Vac, 60Hz	Andy Ho

LTE Band 12

TEST ITEM	AVAILABLE CHANNEL	TESTED CHANNEL	CHANNEL BANDWIDTH	MODULATION	MODE
ERP	23017 to 23173	23017, 23095, 23173	1.4MHz	QPSK/16QAM	1RB / 0 RB offset
	23025 to 23165	23025, 23095, 23165	3MHz	QPSK/16QAM	1RB / 0 RB offset
	23035 to 23155	23035, 23095, 23155	5MHz	QPSK/16QAM	1RB / 0 RB offset
	23060 to 23130	23060, 23095, 23130	10MHz	QPSK/16QAM	1RB / 0 RB offset
Frequency Stability	23017 to 23173	23095	1.4MHz	QPSK	-
	23025 to 23165	23095	3MHz	QPSK	-
	23035 to 23155	23095	5MHz	QPSK	-
	23060 to 23130	23095	10MHz	QPSK	-
Occupied Bandwidth	23017 to 23173	23017, 23095, 23173	1.4MHz	QPSK/16QAM	Full RB
	23025 to 23165	23025, 23095, 23165	3MHz	QPSK/16QAM	Full RB
	23035 to 23155	23035, 23095, 23155	5MHz	QPSK/16QAM	Full RB
	23060 to 23130	23060, 23095, 23130	10MHz	QPSK/16QAM	Full RB
Peak to Average Ratio	23017 to 23173	23017, 23095, 23173	1.4MHz	QPSK/16QAM	Full RB
	23025 to 23165	23025, 23095, 23165	3MHz	QPSK/16QAM	Full RB
	23035 to 23155	23035, 23095, 23155	5MHz	QPSK/16QAM	Full RB
	23060 to 23130	23060, 23095, 23130	10MHz	QPSK/16QAM	Full RB
Band Edge	23017 to 23173	23017	1.4MHz	QPSK	1 RB / 0 RB Offset
		23173			1 RB / 5 RB Offset
		23017, 23173			6 RB / 0 RB Offset
	23025 to 23165	23025	3MHz	QPSK	1 RB / 0 RB Offset
		23165			1 RB / 14 RB Offset
		23025, 23165			15 RB / 0 RB Offset
	23035 to 23155	23035	5MHz	QPSK	1 RB / 0 RB Offset
		23155			1 RB / 24 RB Offset
		23035, 23155			25 RB / 0 RB Offset
	23060 to 23130	23060	10MHz	QPSK	1 RB / 0 RB Offset
		23130			1 RB / 49 RB Offset
		23060, 23130			50 RB / 0 RB Offset
Conducted Emission	23017 to 23173	23017, 23095, 23173	1.4MHz	QPSK	1RB / 0 RB offset
	23025 to 23165	23025, 23095, 23165	3MHz	QPSK	1RB / 0 RB offset
	23035 to 23155	23035, 23095, 23155	5MHz	QPSK	1RB / 0 RB offset
	23060 to 23130	23060, 23095, 23130	10MHz	QPSK	1RB / 0 RB offset
Radiated Emission	23017 to 23173	23017, 23095, 23173	1.4MHz	QPSK	1RB / 0 RB offset
	23025 to 23165	23025, 23095, 23165	3MHz	QPSK	1RB / 0 RB offset
	23035 to 23155	23035, 23095, 23155	5MHz	QPSK	1RB / 0 RB offset
	23060 to 23130	23060, 23095, 23130	10MHz	QPSK	1RB / 0 RB offset

NOTE:

All supported modulation types were evaluated. The Worst case of QPSK was selected. Therefore, the Frequency Stability, Band Edge, Condcudeted Emission and Radiated Emission were presented under QPSK mode only.

LTE Band 13

TEST ITEM	AVAILABLE CHANNEL	TESTED CHANNEL	CHANNEL BANDWIDTH	MODULATION	MODE
ERP	23205 to 23255	23205, 23230, 23255	5MHz	QPSK	1RB / 0 RB offset
	23230	23230	10MHz	QPSK	1RB / 0 RB offset
Frequency Stability	23205 to 23255	23230	5MHz	QPSK	-
	23230	23230	10MHz	QPSK	-
Occupied Bandwidth	23205 to 23255	23205, 23230, 23255	5MHz	QPSK/16QAM	Full RB
	23230	23230	10MHz	QPSK/16QAM	Full RB
Peak to Average Ratio	23205 to 23255	23205, 23230, 23255	5MHz	QPSK/16QAM	Full RB
	23230	23230	10MHz	QPSK/16QAM	Full RB
Band Edge	23205 to 23255	23205	5MHz	QPSK	1 RB / 0 RB Offset
		23255			1 RB / 24 RB Offset
		23205, 23255			25 RB / 0 RB Offset
	23230	23230	10MHz	QPSK	1 RB / 0 RB Offset
					1 RB / 49 RB Offset
					50 RB / 0 RB Offset
Condcudeted Emission	23205 to 23255	23230	5MHz	QPSK	1RB / 0 RB offset
	23230	23230	10MHz	QPSK	1RB / 0 RB offset
Radiated Emission	23205 to 23255	23230	5MHz	QPSK	1RB / 0 RB offset
	23230	23230	10MHz	QPSK	1RB / 0 RB offset

NOTE:

All supported modulation types were evaluated. The Worst case of QPSK was selected. Therefore, the Frequency Stability, Band Edge, Condcudeted Emission and Radiated Emission were presented under QPSK mode only.

Test Condition:

Test Item	Environmental Conditions	Input Power (System)	Tested By
ERP	25deg. C, 60%RH	120Vac, 60Hz	Jynuchun Lin
Frequency Stability	25deg. C, 60%RH	120Vac, 60Hz	Jynuchun Lin
Occupied Bandwidth	25deg. C, 60%RH	120Vac, 60Hz	Jynuchun Lin
Band Edge	25deg. C, 60%RH	120Vac, 60Hz	Jynuchun Lin
Peak to Average Ratio	25deg. C, 60%RH	120Vac, 60Hz	Jynuchun Lin
Condcudeted Emission	25deg. C, 60%RH	120Vac, 60Hz	Jynuchun Lin
Radiated Emission Below 1GHz	24deg. C, 79%RH	120Vac, 60Hz	Andy Ho
Radiated Emission Above 1GHz	25deg. C, 75%RH	120Vac, 60Hz	Andy Ho

3.4 EUT Operating Conditions

The communication simulator station system controlled a EUT to export maximum output power under transmission mode and specific channel frequency

3.5 General Description of Applied Standards

The EUT is a RF Product. According to the specifications of the manufacturer, it must comply with the requirements of the following standards:

FCC 47 CFR Part 2

FCC 47 CFR Part 27, Subpart H / L / F

KDB 971168 D01 Power Meas License Digital Systems v03r01

ANSI/TIA/EIA-603-E 2016

ANSI 63.26-2015

NOTE: All test items have been performed and recorded as per the above standards.

4 Test Types and Results

4.1 Output Power Measurement

4.1.1 Limits of Output Power Measurement

For section 27.50(d)(4): Fixed, mobile, and portable (hand-held) stations operating in the 1710-1755 MHz band and mobile and portable stations operating in the 1695-1710 MHz and 1755-1780 MHz bands are limited to 1 watt EIRP.

For section 27.50(b)(10): Portable stations (hand-held devices) operating in the 698-787 MHz band are limited to 3 watts ERP.

4.1.2 Test Procedures

Conducted Power Measurement:

The EUT was set up for the maximum power with LTE link data modulation and link up with simulator. Set the EUT to transmit under low, middle and high channel and difference RB size/ RB offset for difference bandwidth record the power level shown on power meter.

EIRP / ERP Measurement:

- a. $EIRP = \text{Conducted Output power level} + \text{Antenna gain}$.
- b. ERP power can be calculated from EIRP power by subtracting the gain of dipole, $ERP \text{ power} = EIRP \text{ power} - 2.15dBi$.
- c. $ERP = \text{Conducted Output power level} + \text{Antenna gain (dBi)} - \text{Isotropically Factor (2.15dB)}$

4.1.3 Test Setup

Conducted Power Measurement:

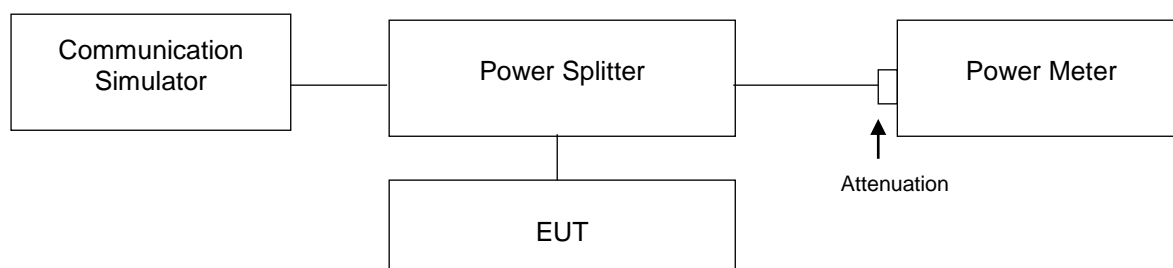

4.1.4 Test Results

CONDUCTED OUTPUT POWER (dBm)
LTE Band 4

Band / BW	RB Size	RB Offset	QPSK			3GPP MPR (dB)	16QAM			3GPP MPR (dB)
			Low CH	Mid CH	High CH		Low CH	Mid CH	High CH	
			19957	20175	20393		19957	20175	20393	
			1710.7	1732.5	1754.3		1710.7	1732.5	1754.3	
			MHz	MHz	MHz		MHz	MHz	MHz	
4 / 1.4M	1	0	22.80	22.50	21.77	0	21.57	21.60	20.90	1
	1	2	22.77	22.44	21.94	0	21.52	21.63	20.93	1
	1	5	22.71	22.27	21.95	0	21.75	21.81	21.35	1
	3	0	22.75	22.35	21.88	0	21.67	21.39	21.13	1
	3	1	22.68	22.47	20.78	0	21.65	21.34	20.96	1
	3	3	22.74	22.32	21.69	0	21.32	21.37	20.89	1
	6	0	21.64	21.47	21.63	1	20.63	20.37	19.81	2

Band / BW	RB Size	RB Offset	QPSK			3GPP MPR (dB)	16QAM			3GPP MPR (dB)
			Low CH	Mid CH	High CH		Low CH	Mid CH	High CH	
			19965	20175	20385		19965	20175	20385	
			1711.5	1732.5	1753.5		1711.5	1732.5	1753.5	
			MHz	MHz	MHz		MHz	MHz	MHz	
4 / 3M	1	0	22.97	22.46	22.12	0	21.78	21.39	21.42	1
	1	7	22.78	22.36	21.72	0	21.22	21.34	21.40	1
	1	14	22.77	22.18	21.01	0	21.68	21.60	21.38	1
	8	0	21.70	21.44	20.91	1	20.67	20.25	19.90	2
	8	3	21.77	21.45	20.87	1	20.64	20.21	19.55	2
	8	7	21.72	21.36	20.87	1	20.88	20.42	19.64	2
	15	0	21.65	21.40	21.78	1	20.89	20.41	19.68	2

Band / BW	RB Size	RB Offset	QPSK			3GPP MPR (dB)	16QAM			3GPP MPR (dB)
			Low CH	Mid CH	High CH		Low CH	Mid CH	High CH	
			19975	20175	20375		19975	20175	20375	
			1712.5	1732.5	1752.5		1712.5	1732.5	1752.5	
			MHz	MHz	MHz		MHz	MHz	MHz	
4 / 5M	1	0	22.76	22.36	22.38	0	20.97	21.62	20.95	1
	1	12	22.55	22.29	22.02	0	21.09	21.79	20.90	1
	1	24	22.75	21.44	21.87	0	21.36	21.70	20.83	1
	12	0	21.61	21.19	21.02	1	21.68	20.47	20.12	2
	12	6	21.64	21.24	21.02	1	20.53	20.45	19.81	2
	12	13	21.63	21.41	21.03	1	20.55	20.20	19.66	2
	25	0	21.61	21.35	20.98	1	20.76	20.34	19.79	2

Band / BW	RB Size	RB Offset	QPSK			3GPP MPR (dB)	16QAM			3GPP MPR (dB)
			Low CH	Mid CH	High CH		Low CH	Mid CH	High CH	
			20000	20175	20350		20000	20175	20350	
			1715	1732.5	1750		1715	1732.5	1750	
			MHz	MHz	MHz		MHz	MHz	MHz	
4 / 10M	1	0	22.91	22.86	22.98	0	21.72	21.39	21.45	1
	1	24	22.82	22.46	22.74	0	21.30	21.43	21.53	1
	1	49	22.53	22.68	22.11	0	21.62	21.12	21.04	1
	25	0	21.77	21.46	21.18	1	20.67	20.56	20.08	2
	25	12	21.81	21.52	20.85	1	20.72	20.51	20.25	2
	25	25	21.71	21.47	21.12	1	20.58	20.13	19.93	2
	50	0	21.70	21.29	21.63	1	20.48	20.18	19.89	2

Band / BW	RB Size	RB Offset	QPSK			3GPP MPR (dB)	16QAM			3GPP MPR (dB)
			Low CH	Mid CH	High CH		Low CH	Mid CH	High CH	
			20025	20175	20325		20025	20175	20325	
			1717.5	1732.5	1747.5		1717.5	1732.5	1747.5	
			MHz	MHz	MHz		MHz	MHz	MHz	
4 / 15M	1	0	22.87	22.49	22.37	0	20.57	21.31	21.11	1
	1	37	22.65	22.69	22.39	0	21.69	21.85	21.47	1
	1	74	22.56	22.00	22.08	0	21.17	21.34	20.99	1
	36	0	21.51	21.47	21.03	1	20.47	20.20	20.22	2
	36	19	21.63	21.31	21.25	1	20.50	20.16	20.19	2
	36	39	21.57	21.23	21.06	1	20.53	20.16	19.99	2
	75	0	21.65	21.37	21.08	1	20.65	20.33	20.02	2

Band / BW	RB Size	RB Offset	QPSK			3GPP MPR (dB)	16QAM			3GPP MPR (dB)
			Low CH	Mid CH	High CH		Low CH	Mid CH	High CH	
			20050	20175	20300		20050	20175	20300	
			1720	1732.5	1745		1720	1732.5	1745	
			MHz	MHz	MHz		MHz	MHz	MHz	
4 / 20M	1	0	23.02	22.68	22.45	0	21.16	21.26	21.44	1
	1	50	22.28	22.39	22.51	0	21.06	21.42	21.80	1
	1	99	22.51	22.21	21.24	0	21.71	20.89	20.91	1
	50	0	21.67	21.36	21.27	1	20.51	20.40	20.11	2
	50	25	21.71	21.22	21.06	1	20.21	20.26	20.23	2
	50	50	21.56	21.18	21.10	1	20.71	20.13	20.11	2
	100	0	21.62	21.36	21.69	1	20.73	20.42	20.04	2

LTE Band 12

Band / BW	RB Size	RB Offset	QPSK			3GPP MPR (dB)	16QAM			3GPP MPR (dB)
			Low CH	Mid CH	High CH		Low CH	Mid CH	High CH	
			23017	23095	23173		23017	23095	23173	
			699.7	707.5	715.3		699.7	707.5	715.3	
			MHz	MHz	MHz	MHz	MHz	MHz		
12 / 1.4M	1	0	24.27	24.19	24.09	0	23.11	23.16	23.00	1
	1	2	24.04	24.08	24.05	0	23.13	23.04	23.13	1
	1	5	24.05	24.03	24.01	0	22.76	23.09	23.12	1
	3	0	21.01	24.01	23.97	0	22.75	23.19	23.13	1
	3	1	21.06	24.09	24.01	0	22.95	23.11	23.02	1
	3	3	24.06	24.04	23.00	0	23.07	23.15	23.21	1
	6	0	23.11	23.09	23.06	1	21.73	22.04	21.98	2

Band / BW	RB Size	RB Offset	QPSK			3GPP MPR (dB)	16QAM			3GPP MPR (dB)
			Low CH	Mid CH	High CH		Low CH	Mid CH	High CH	
			23025	23095	23165		23025	23095	23165	
			700.5	707.5	714.5		700.5	707.5	714.5	
			MHz	MHz	MHz	MHz	MHz	MHz		
12 / 3M	1	0	24.20	24.33	24.01	0	23.13	23.16	23.10	1
	1	7	23.86	24.03	23.98	0	23.15	23.05	23.16	1
	1	14	23.87	24.11	23.93	0	23.10	23.15	23.23	1
	8	0	23.10	23.17	23.06	1	22.18	22.06	22.13	2
	8	3	23.24	23.22	22.94	1	22.20	22.00	22.05	2
	8	7	23.08	23.16	22.86	1	22.05	22.17	21.95	2
	15	0	23.08	23.21	23.00	1	22.22	22.04	22.12	2

Band / BW	RB Size	RB Offset	QPSK			3GPP MPR (dB)	16QAM			3GPP MPR (dB)	
			Low CH	Mid CH	High CH		Low CH	Mid CH	High CH		
			23035	23095	23155		23035	23095	23155		
			701.5	707.5	713.5		701.5	707.5	713.5		
			MHz	MHz	MHz						
12 / 5M	1	0	24.13	24.29	23.94	0	23.02	23.12	22.87	1	
	1	12	24.00	23.46	23.79	0	23.11	23.03	22.79	1	
	1	24	24.08	23.85	23.13	0	23.16	23.15	22.89	1	
	12	0	23.12	23.08	23.02	1	22.01	22.05	21.76	2	
	12	6	23.03	23.00	22.92	1	21.97	22.10	21.88	2	
	12	13	23.00	23.17	22.85	1	22.05	22.16	21.91	2	
	25	0	23.06	23.01	23.09	1	22.16	22.12	21.99	2	

Band / BW	RB Size	RB Offset	QPSK			3GPP MPR (dB)	16QAM			3GPP MPR (dB)	
			Low CH	Mid CH	High CH		Low CH	Mid CH	High CH		
			23060	23095	23130		23060	23095	23130		
			704	707.5	711		704	707.5	711		
			MHz	MHz	MHz						
12 / 10M	1	0	24.49	24.40	24.33	0	23.02	22.72	23.30	1	
	1	24	24.01	24.05	24.02	0	23.17	23.24	23.18	1	
	1	49	24.03	24.00	23.80	0	23.22	22.90	23.21	1	
	25	0	23.12	23.18	23.37	1	22.13	22.16	22.14	2	
	25	12	23.13	23.27	23.23	1	22.15	22.20	22.15	2	
	25	25	23.09	22.96	23.03	1	22.03	22.08	21.92	2	
	50	0	23.15	23.09	23.05	1	22.18	22.14	21.87	2	

LTE Band 13

Band / BW	RB Size	RB Offset	QPSK			3GPP MPR (dB)	16QAM			3GPP MPR (dB)
			Low CH	Mid CH	High CH		Low CH	Mid CH	High CH	
			23205	23230	23255		23205	23230	23255	
			779.5 MHz	782 MHz	784.5 MHz		779.5 MHz	782 MHz	784.5 MHz	
13 / 5M	1	0	24.53	24.33	24.22	0	23.15	23.22	23.19	1
	1	12	24.14	23.91	24.10	0	23.04	23.09	23.11	1
	1	24	24.25	24.03	24.09	0	23.13	23.05	22.89	1
	12	0	23.19	23.27	23.25	1	22.00	21.85	22.19	2
	12	6	23.31	23.29	23.34	1	22.08	21.94	22.15	2
	12	13	23.28	23.33	23.21	1	21.75	22.09	22.16	2
	25	0	23.21	23.22	23.19	1	22.11	22.18	22.10	2

Band / BW	RB Size	RB Offset	QPSK		3GPP MPR (dB)	16QAM		3GPP MPR (dB)
			Mid CH			Mid CH		
			23230			23230		
			782			782		
			MHz			MHz		
13 / 10M	1	0	24.17		0	23.05		1
	1	24	23.93		0	23.01		1
	1	49	24.07		0	23.06		1
	25	0	23.06		1	22.08		2
	25	12	23.09		1	22.11		2
	25	25	23.02		1	22.04		2
	50	0	23.08		1	22.06		2

EIRP / ERP POWER
LTE Band 4

Band / BW	RB Size	RB Offset	QPSK			3GPP MPR (dB)	16QAM			3GPP MPR (dB)
			Low CH	Mid CH	High CH		Low CH	Mid CH	High CH	
			19957	20175	20393		19957	20175	20393	
			1710.7	1732.5	1754.3		1710.7	1732.5	1754.3	
MHz	MHz	MHz	MHz	MHz	MHz					
4 / 1.4M	1	0	22.80	22.50	21.77	0	21.57	21.60	20.90	1
Gain (dBi)		1.62	1.62	1.62	1.62	1.62	1.62			
Max EIRP Power (dBm)		24.42	24.12	23.39	23.19	23.22	22.52			

Band / BW	RB Size	RB Offset	QPSK			3GPP MPR (dB)	16QAM			3GPP MPR (dB)
			Low CH	Mid CH	High CH		Low CH	Mid CH	High CH	
			19965	20175	20385		19965	20175	20385	
			1711.5	1732.5	1753.5		1711.5	1732.5	1753.5	
MHz	MHz	MHz	MHz	MHz	MHz					
4 / 3M	1	0	22.97	22.46	22.12	0	21.78	21.39	21.42	1
Gain (dBi)		1.62	1.62	1.62	1.62	1.62	1.62			
Max EIRP Power (dBm)		24.59	24.08	23.74	23.40	23.01	23.04			

Band / BW	RB Size	RB Offset	QPSK			3GPP MPR (dB)	16QAM			3GPP MPR (dB)
			Low CH	Mid CH	High CH		Low CH	Mid CH	High CH	
			19975	20175	20375		19975	20175	20375	
			1712.5	1732.5	1752.5		1712.5	1732.5	1752.5	
MHz	MHz	MHz	MHz	MHz	MHz					
4 / 5M	1	0	22.76	22.36	22.38	0	20.97	21.62	20.95	1
Gain (dBi)		1.62	1.62	1.62	1.62	1.62	1.62			
Max EIRP Power (dBm)		24.38	23.98	24.00	22.59	23.24	22.57			

Band / BW	RB Size	RB Offset	QPSK			3GPP MPR (dB)	16QAM			3GPP MPR (dB)
			Low CH	Mid CH	High CH		Low CH	Mid CH	High CH	
			20000	20175	20350		20000	20175	20350	
			1715	1732.5	1750		1715	1732.5	1750	
MHz	MHz	MHz	MHz	MHz	MHz					
4 / 10M	1	0	22.91	22.86	22.98	0	21.72	21.39	21.45	1
Gain (dBi)		1.62	1.62	1.62	1.62	1.62	1.62			
Max EIRP Power (dBm)		24.53	24.48	24.60	23.34	23.01	23.07			

Band / BW	RB Size	RB Offset	QPSK			3GPP MPR (dB)	16QAM			3GPP MPR (dB)
			Low CH	Mid CH	High CH		Low CH	Mid CH	High CH	
			20025	20175	20325		20025	20175	20325	
			1717.5	1732.5	1747.5		1717.5	1732.5	1747.5	
			MHz	MHz	MHz	MHz	MHz			
4 / 15M	1	0	22.87	22.49	22.37	0	20.57	21.31	21.11	1
Gain (dBi)			1.62	1.62	1.62		1.62	1.62	1.62	
Max EIRP Power (dBm)			24.49	24.11	23.99		22.19	22.93	22.73	

Band / BW	RB Size	RB Offset	QPSK			3GPP MPR (dB)	16QAM			3GPP MPR (dB)
			Low CH	Mid CH	High CH		Low CH	Mid CH	High CH	
			20050	20175	20300		20050	20175	20300	
			1720	1732.5	1745		1720	1732.5	1745	
			MHz	MHz	MHz	MHz	MHz			
4 / 20M	1	0	23.02	22.68	22.45	0	21.16	21.26	21.44	1
Gain (dBi)			1.62	1.62	1.62		1.62	1.62	1.62	
Max EIRP Power (dBm)			24.64	24.30	24.07		22.78	22.88	23.06	

LTE Band 12

Band / BW	RB Size	RB Offset	QPSK			3GPP MPR (dB)	16QAM			3GPP MPR (dB)
			Low CH	Mid CH	High CH		Low CH	Mid CH	High CH	
			23017	23095	23173		23017	23095	23173	
			699.7	707.5	715.3		699.7	707.5	715.3	
	MHz	MHz	MHz	MHz	MHz	MHz				
12 / 1.4M	1	0	24.27	24.19	24.09	0	23.11	23.16	23.00	1
Gain (dBi)		1.49	1.49	1.49	1.49	1.49	1.49	1.49		
Isotropically Factor (dBc)		2.15	2.15	2.15	2.15	2.15	2.15	2.15		
Max ERP Power (dBm)		23.61	23.53	23.43	22.45	22.50	22.34			

Band / BW	RB Size	RB Offset	QPSK			3GPP MPR (dB)	16QAM			3GPP MPR (dB)
			Low CH	Mid CH	High CH		Low CH	Mid CH	High CH	
			23025	23095	23165		23025	23095	23165	
			700.5	707.5	714.5		700.5	707.5	714.5	
	MHz	MHz	MHz	MHz	MHz	MHz				
12 / 3M	1	0	24.20	24.33	24.01	0	23.13	23.16	23.10	1
Gain (dBi)		1.49	1.49	1.49	1.49	1.49	1.49			
Isotropically Factor (dBc)		2.15	2.15	2.15	2.15	2.15	2.15			
Max ERP Power (dBm)		23.54	23.67	23.35	22.47	22.50	22.44			

Band / BW	RB Size	RB Offset	QPSK			3GPP MPR (dB)	16QAM			3GPP MPR (dB)
			Low CH	Mid CH	High CH		Low CH	Mid CH	High CH	
			23035	23095	23155		23035	23095	23155	
			701.5	707.5	713.5		701.5	707.5	713.5	
	MHz	MHz	MHz	MHz	MHz	MHz				
12 / 5M	1	0	24.13	24.29	23.94	0	23.02	23.12	22.87	1
Gain (dBi)		1.49	1.49	1.49	1.49	1.49	1.49			
Isotropically Factor (dBc)		2.15	2.15	2.15	2.15	2.15	2.15			
Max ERP Power (dBm)		23.47	23.63	23.28	22.36	22.46	22.21			

Band / BW	RB Size	RB Offset	QPSK			3GPP MPR (dB)	16QAM			3GPP MPR (dB)
			Low CH	Mid CH	High CH		Low CH	Mid CH	High CH	
			23060	23095	23130		23060	23095	23130	
			704	707.5	711		704	707.5	711	
	MHz	MHz	MHz	MHz	MHz	MHz				
12 / 10M	1	0	24.49	24.40	24.33	0	23.02	22.72	23.30	1
Gain (dBi)		1.49	1.49	1.49	1.49	1.49	1.49			
Isotropically Factor (dBc)		2.15	2.15	2.15	2.15	2.15	2.15			
Max ERP Power (dBm)		23.83	23.74	23.67	22.36	22.06	22.64			

LTE Band 13

Band / BW	RB Size	RB Offset	QPSK			3GPP MPR (dB)	16QAM			3GPP MPR (dB)
			Low CH	Mid CH	High CH		Low CH	Mid CH	High CH	
			23205	23230	23255		23205	23230	23255	
			779.5	782	784.5		779.5	782	784.5	
			MHz	MHz	MHz	MHz	MHz	MHz		
13 / 5M	1	0	24.53	24.33	24.22	0	23.15	23.22	23.19	1
Gain (dBi)			1.66	1.66	1.66		1.66	1.66	1.66	
Isotropically Factor (dBc)			2.15	2.15	2.15		2.15	2.15	2.15	
Max ERP Power (dBm)			24.04	23.84	23.73		22.66	22.73	22.70	

Band / BW	RB Size	RB Offset	QPSK		3GPP MPR (dB)	16QAM		3GPP MPR (dB)
			Mid CH	Mid CH				
			23230	23230				
			782	782				
			MHz	MHz				
13 / 10M	1	0	24.17	23.05	0	23.05	1	
Gain (dBi)			1.66	1.66				
Isotropically Factor (dBc)			2.15	2.15				
Max ERP Power (dBm)			23.68	22.56				

4.2 Modulation characteristics Measurement

4.2.1 Limits of Modulation characteristics

N/A

4.2.2 Test Procedure

Connect the EUT to Communication Simulator via the antenna connector. The frequency band is set as EUT supported Modulation and Channels, the EUT output is matched with 50 ohm load, the waveform quality and constellation of the EUT was tested.

4.2.3 Test Setup



4.2.4 Test Results

LTE Band 4

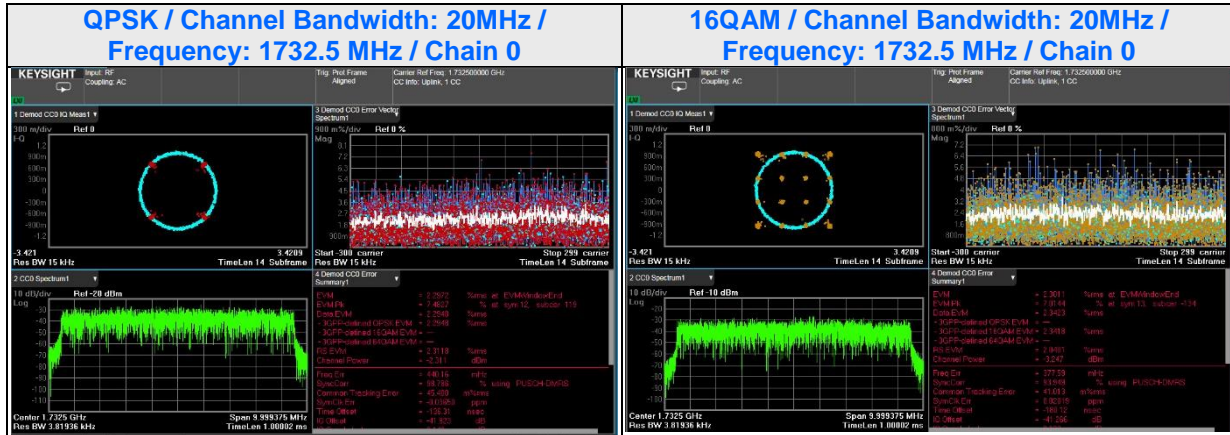

LTE Band 12

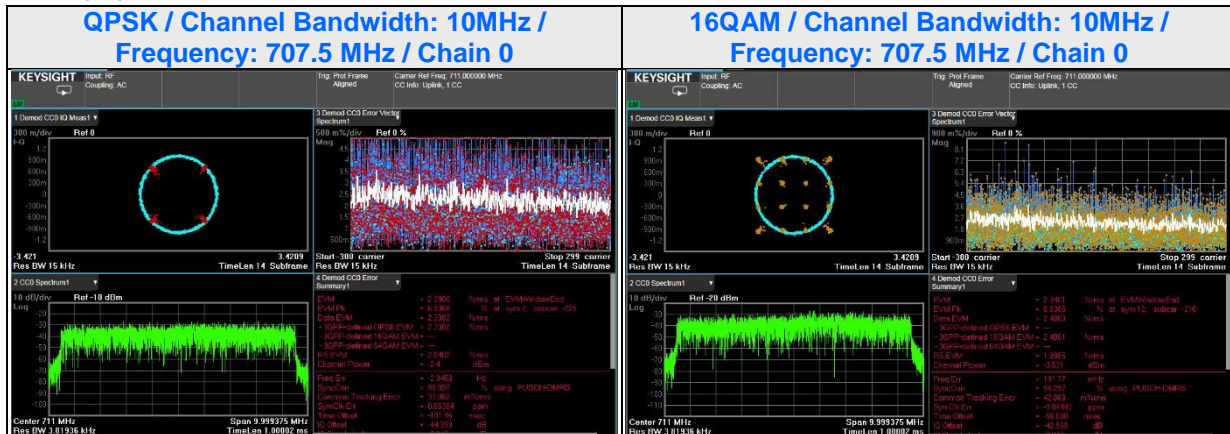

LTE Band 13

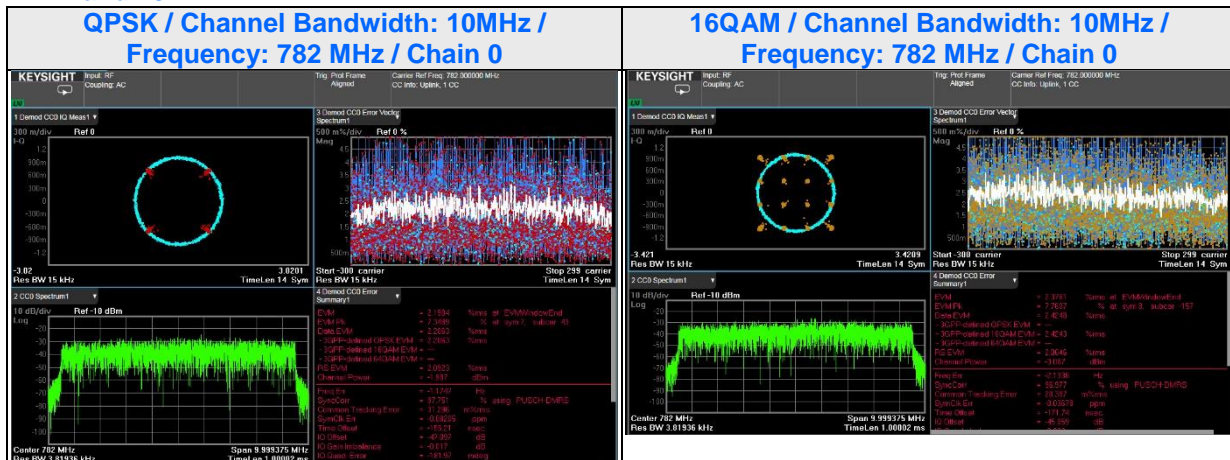

4.3 Frequency Stability Measurement

4.3.1 Limits of Frequency Stability Measurement

The frequency stability shall be sufficient to ensure that the fundamental emissions stay within the authorized bands of operation.

According to the FCC part 2.1055 shall be tested the frequency stability. The rule is defined that "The frequency stability shall be sufficient to ensure that the fundamental emission stays within the authorized frequency block." The test extreme voltage is according to the 2.1055(d)(1) Vary primary supply voltage from 85 to 115 percent of the nominal value for other than hand carried battery equipment and the extreme temperature rule is comply with specification of EUT $-30^{\circ}\text{C} \sim 60^{\circ}\text{C}$.

4.3.2 Test Procedure

- a. Device is placed at the oven room. The oven room could control the temperatures and humidity. Power warm up is at least 15 min and power applied should perform before recording frequency error.
- b. EUT is connected the external power supply to control the DC input power. The test voltage range is from minimum to maximum working voltage. Each step shall be record the frequency error rate.
- c. The temperature range step is 10 degrees in this test items. All temperature levels shall be hold the $\pm 0.5^{\circ}\text{C}$ during the measurement testing. The each temperature step shall be at least 0.5 hours, consider the EUT could be test under the stability condition.

NOTE: The frequency error was recorded frequency error from the communication simulator.

4.3.3 Test Setup

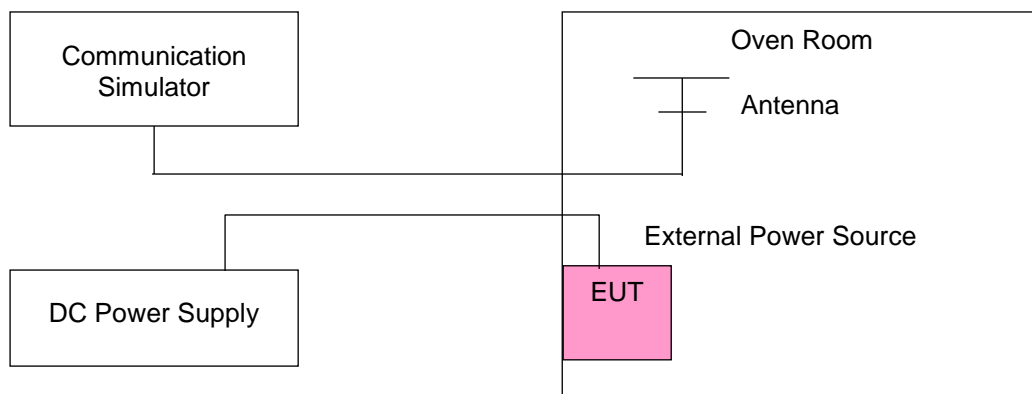

4.3.4 Test Results

LTE Band 4

Voltage (Volts)	Frequency Error (MHz)												Limit (MHz)	
	1.4MHz		3MHz		5MHz		10MHz		15MHz		20MHz			
	Low	High	Low	High	Low	High	Low	High	Low	High	Low	High	Low Edge	High Edge
3.23	1710.06	1754.78	1710.06	1754.91	1710.34	1754.73	1710.48	1754.40	1710.68	1754.20	1711.08	1754.03	1710	1755
4.37	1710.14	1754.76	1710.03	1754.87	1710.18	1754.70	1710.58	1754.46	1710.86	1754.32	1710.95	1754.07	1710	1755

Temp. (°C)	Frequency Error (MHz)												Limit (MHz)	
	1.4MHz		3MHz		5MHz		10MHz		15MHz		20MHz			
	Low	High	Low	High	Low	High	Low	High	Low	High	Low	High	Low	High
60	1710.09	1754.82	1710.14	1754.90	1710.33	1754.84	1710.48	1754.46	1710.80	1754.27	1710.97	1754.09	1710	1755
50	1710.10	1754.76	1710.03	1754.77	1710.27	1754.82	1710.58	1754.56	1710.80	1754.30	1710.97	1754.04	1710	1755
40	1710.19	1754.88	1710.21	1754.83	1710.21	1754.80	1710.43	1754.52	1710.77	1754.20	1711.04	1754.05	1710	1755
30	1710.23	1754.77	1710.03	1754.92	1710.32	1754.67	1710.50	1754.50	1710.82	1754.25	1710.96	1754.01	1710	1755
20	1710.17	1754.88	1710.14	1754.86	1710.26	1754.83	1710.55	1754.53	1710.75	1754.33	1710.97	1753.98	1710	1755
10	1710.14	1754.81	1710.18	1754.94	1710.27	1754.68	1710.44	1754.55	1710.74	1754.26	1711.09	1753.96	1710	1755
0	1710.18	1754.87	1710.21	1754.76	1710.32	1754.78	1710.49	1754.46	1710.69	1754.18	1711.13	1753.91	1710	1755
-10	1710.10	1754.89	1710.12	1754.78	1710.19	1754.72	1710.42	1754.58	1710.85	1754.15	1710.97	1753.98	1710	1755
-20	1710.11	1754.89	1710.08	1754.94	1710.22	1754.83	1710.45	1754.51	1710.79	1754.26	1711.04	1754.02	1710	1755
-30	1710.21	1754.81	1710.19	1754.82	1710.21	1754.66	1710.54	1754.42	1710.78	1754.25	1710.95	1754.04	1710	1755

LTE Band 12

Voltage (Volts)	Frequency Error (MHz)								Limit (MHz)	
	1.4MHz		3MHz		5MHz		10MHz			
	Low	High	Low	High	Low	High	Low	High	Low Edge	High Edge
3.23	699.10	715.81	699.14	715.90	699.18	715.79	699.58	715.55	699	716
4.37	699.07	715.87	699.23	715.75	699.24	715.74	699.53	715.46	699	716

Temp. (°C)	Frequency Error (MHz)								Limit (MHz)	
	1.4MHz		3MHz		5MHz		10MHz			
	Low	High	Low	High	Low	High	Low	High	Low Edge	High Edge
60	699.23	715.82	699.11	715.77	699.27	715.80	699.54	715.45	699	716
50	699.18	715.83	699.18	715.93	699.19	715.84	699.50	715.43	699	716
40	699.07	715.88	699.11	715.91	699.34	715.79	699.47	715.53	699	716
30	699.23	715.92	699.16	715.75	699.18	715.75	699.52	715.50	699	716
20	699.23	715.90	699.16	715.75	699.33	715.67	699.49	715.41	699	716
10	699.06	715.78	699.05	715.77	699.21	715.70	699.56	715.47	699	716
0	699.13	715.87	699.22	715.92	699.28	715.74	699.59	715.41	699	716
-10	699.16	715.75	699.24	715.89	699.23	715.69	699.53	715.47	699	716
-20	699.06	715.94	699.10	715.75	699.23	715.67	699.56	715.40	699	716
-30	699.12	715.88	699.24	715.92	699.15	715.78	699.46	715.47	699	716

LTE Band 13

Voltage (Volts)	Frequency Error (MHz)				Limit (MHz)	
	5MHz		10MHz			
	Low	High	Low	High	Low Edge	High Edge
3.23	777.18	786.83	777.61	786.53	777	787
4.37	777.33	786.71	777.59	786.41	777	787

Temp. (°C)	Frequency Error (MHz)				Limit (MHz)	
	5MHz		10MHz			
	Low	High	Low	High	Low Edge	High Edge
60	777.16	786.82	777.49	786.55	777	787
50	777.15	786.68	777.54	786.51	777	787
40	777.33	786.69	777.51	786.44	777	787
30	777.32	786.80	777.61	786.51	777	787
20	777.32	786.79	777.52	786.45	777	787
10	777.25	786.83	777.52	786.48	777	787
0	777.25	786.82	777.61	786.51	777	787
-10	777.27	786.83	777.49	786.46	777	787
-20	777.29	786.77	777.44	786.38	777	787
-30	777.16	786.73	777.55	786.52	777	787

4.4 Emission Bandwidth Measurement

4.4.1 Limits of Emission Bandwidth Measurement

-26dB Bandwidth

According to FCC 27.53 specified that emission bandwidth is defined as the width of the signal between two points, one below the carrier center frequency and one above the carrier center frequency, outside of which all emissions are attenuated at least 26dB below the transmitter power.

Occupied Bandwidth

The EUT makes a call to the communication simulator. All measurements were done at low, middle and high operational frequency range. The communication simulator station system controlled a EUT to export maximum output power under transmission mode and specific channel frequency. Use OBW measurement function of Spectrum analyzer to measure 99 % occupied bandwidth.

4.4.2 Test Procedure

The transmitter output was connected to the spectrum analyzer through an attenuator. The bandwidth of the fundamental frequency was measured by spectrum analyzer with $RBW \geq 1\% \times OBW$ and $VBW \geq 3 \times VBW$.

4.4.3 Test Setup

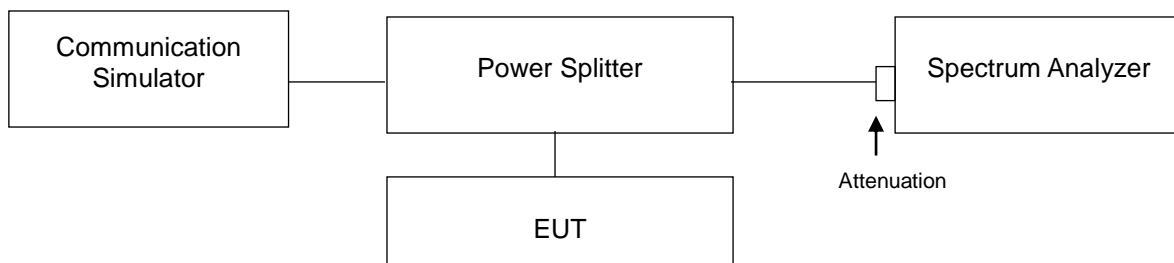

4.4.4 Test Results (-26dB Bandwidth)

LTE Band 4							
Channel Bandwidth 1.4MHz				Channel Bandwidth 3MHz			
Channel	Frequency (MHz)	-26dB Bandwidth (MHz)		Channel	Frequency (MHz)	-26dB Bandwidth (MHz)	
		QPSK	16QAM			QPSK	16QAM
19957	1710.7	1.28	1.28	19965	1711.5	2.94	2.95
20175	1732.5	1.28	1.29	20175	1732.5	2.98	2.96
20393	1754.3	1.29	1.29	20385	1753.5	2.95	2.96
Channel Bandwidth 5MHz				Channel Bandwidth 10MHz			
Channel	Frequency (MHz)	-26dB Bandwidth (MHz)		Channel	Frequency (MHz)	-26dB Bandwidth (MHz)	
		QPSK	16QAM			QPSK	16QAM
19975	1712.5	4.95	4.99	20000	1715	9.89	9.92
20175	1732.5	4.99	4.96	20175	1732.5	9.86	9.90
20375	1752.5	5.01	4.98	20350	1750	9.90	9.88
Channel Bandwidth 15MHz				Channel Bandwidth 20MHz			
Channel	Frequency (MHz)	-26dB Bandwidth (MHz)		Channel	Frequency (MHz)	-26dB Bandwidth (MHz)	
		QPSK	16QAM			QPSK	16QAM
20025	1717.5	14.64	14.62	20050	1720	19.40	19.41
20175	1732.5	14.64	14.65	20175	1732.5	19.50	19.41
20325	1747.5	14.72	14.76	20300	1745	19.57	19.55

Spectrum Plot of Worst Value

1.4MHz / QPSK

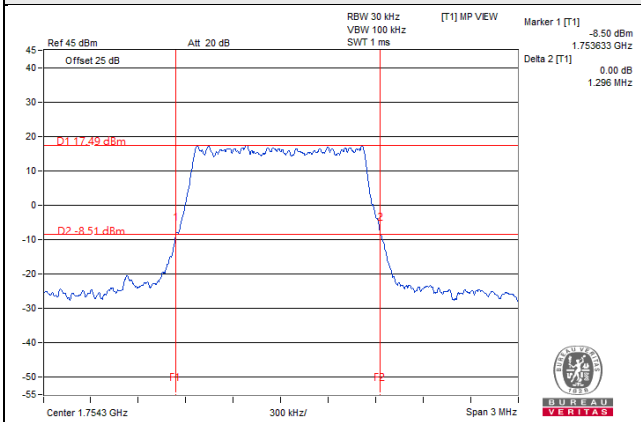

3MHz / QPSK

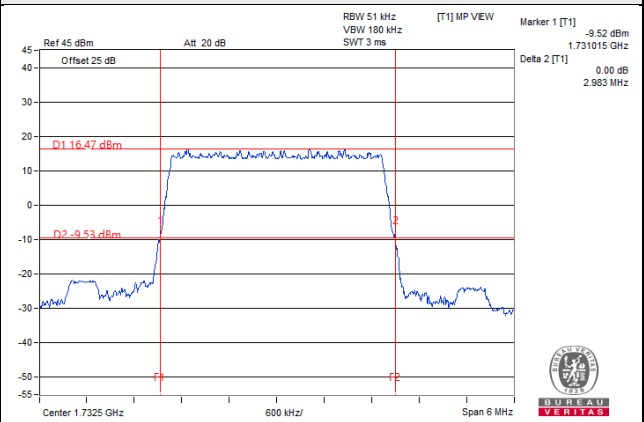

5MHz / QPSK

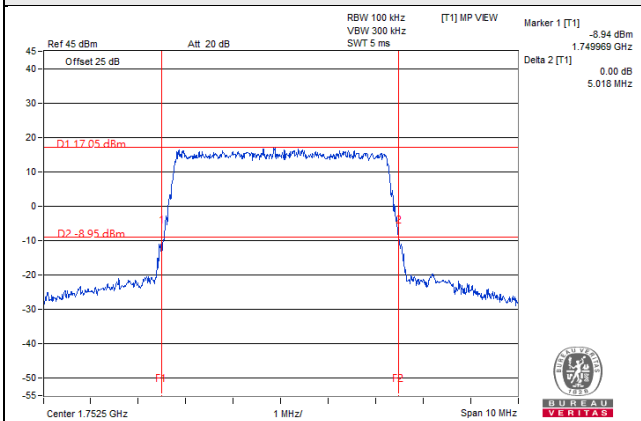

10MHz / 16QAM

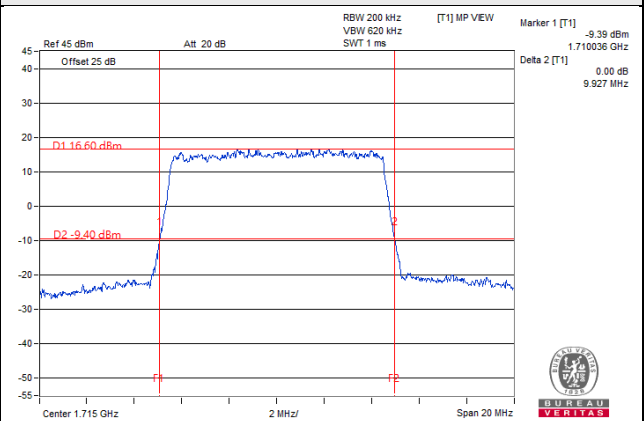

15MHz / 16QAM

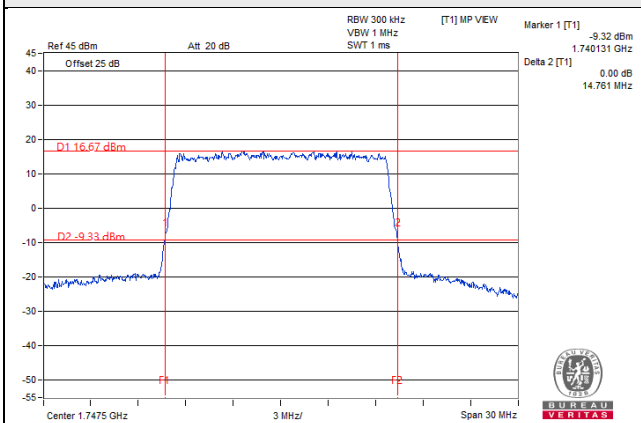

20MHz / QPSK

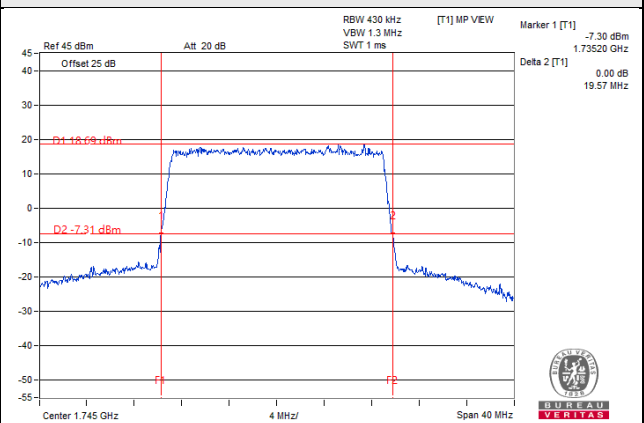

LTE Band 12							
Channel Bandwidth 1.4MHz				Channel Bandwidth 3MHz			
Channel	Frequency (MHz)	-26dB Bandwidth (MHz)		Channel	Frequency (MHz)	-26dB Bandwidth (MHz)	
		QPSK	16QAM			QPSK	16QAM
23017	699.7	1.30	1.30	23025	700.5	2.98	2.95
23095	707.5	1.29	1.29	23095	707.5	2.97	2.96
23173	715.3	1.29	1.29	23165	714.5	2.99	2.95
Channel Bandwidth 5MHz				Channel Bandwidth 10MHz			
Channel	Frequency (MHz)	-26dB Bandwidth (MHz)		Channel	Frequency (MHz)	-26dB Bandwidth (MHz)	
		QPSK	16QAM			QPSK	16QAM
23035	701.5	5.01	4.95	23060	704	9.85	9.90
23095	707.5	5.00	5.00	23095	707.5	9.89	9.95
23155	713.5	4.98	4.96	23130	711	9.76	9.82

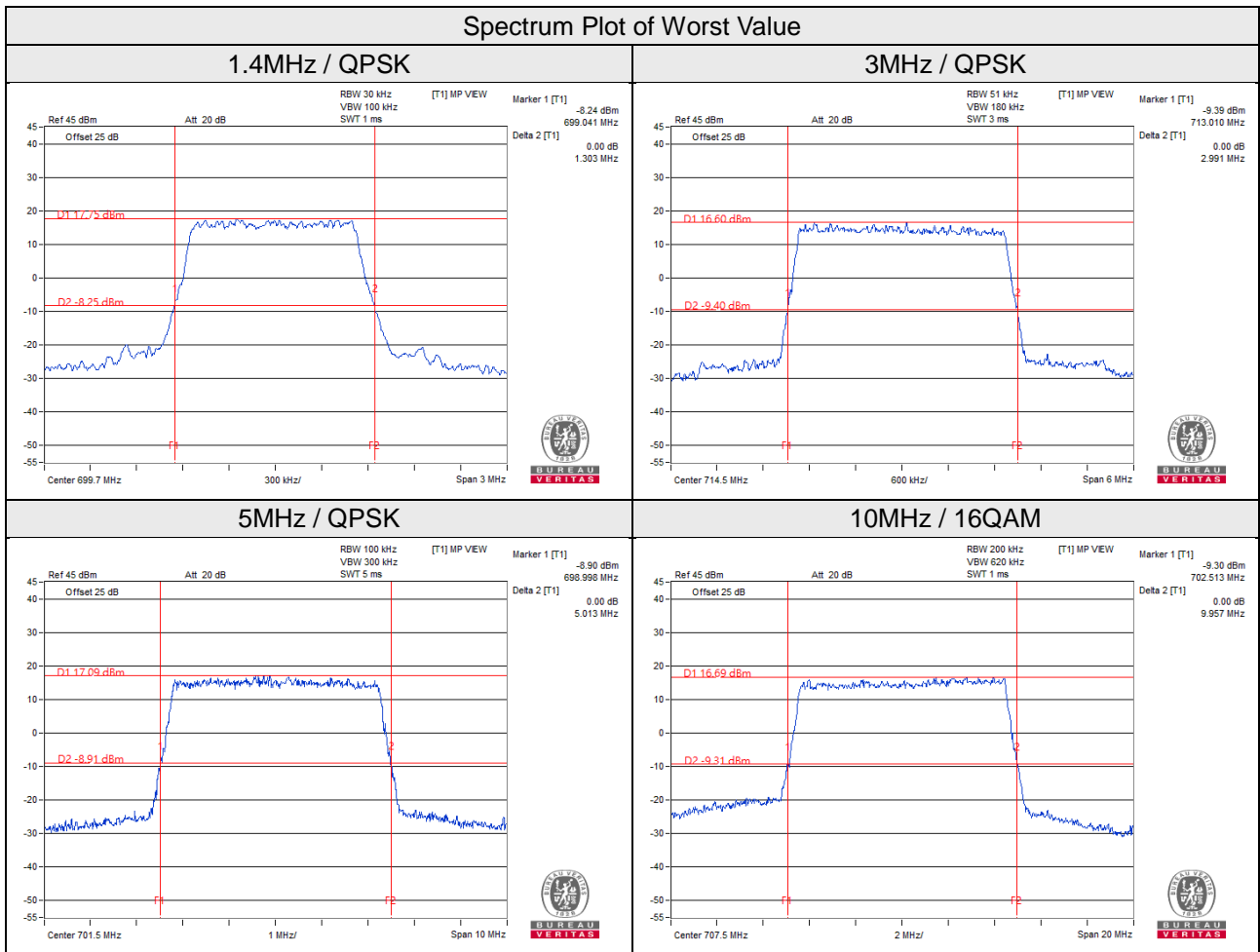

LTE Band 13

Channel Bandwidth 5MHz				Channel Bandwidth 10MHz			
Channel	Frequency (MHz)	-26dB Bandwidth (MHz)		Channel	Frequency (MHz)	-26dB Bandwidth (MHz)	
		QPSK	16QAM			QPSK	16QAM
23205	779.5	4.98	5.00	23230	782	9.85	9.85
23230	782	5.00	4.98				
23255	784.5	4.99	4.96				

Spectrum Plot of Worst Value

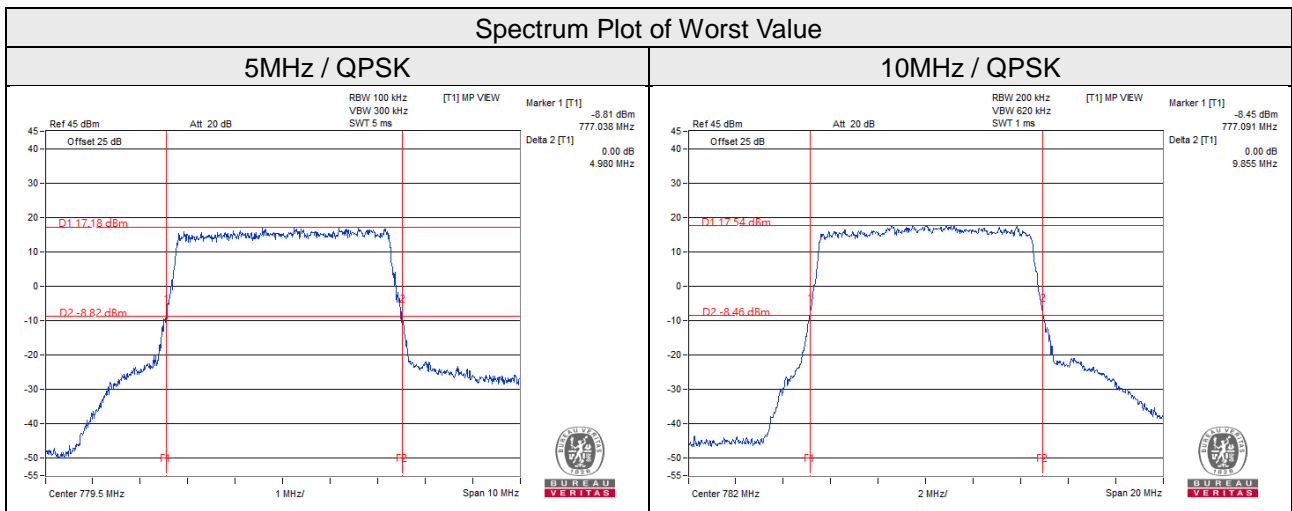

4.4.5 Test Results (Occupied Bandwidth)

LTE Band 4							
Channel Bandwidth 1.4MHz				Channel Bandwidth 3MHz			
Channel	Frequency (MHz)	Occupied Bandwidth (MHz)		Channel	Frequency (MHz)	Occupied Bandwidth (MHz)	
		QPSK	16QAM			QPSK	16QAM
19957	1710.7	1.09	1.10	19965	1711.5	2.70	2.69
20175	1732.5	1.09	1.10	20175	1732.5	2.70	2.68
20393	1754.3	1.09	1.10	20385	1753.5	2.70	2.68
Channel Bandwidth 5MHz				Channel Bandwidth 10MHz			
Channel	Frequency (MHz)	Occupied Bandwidth (MHz)		Channel	Frequency (MHz)	Occupied Bandwidth (MHz)	
		QPSK	16QAM			QPSK	16QAM
19975	1712.5	4.50	4.50	20000	1715	9.00	8.96
20175	1732.5	4.51	4.50	20175	1732.5	8.98	8.98
20375	1752.5	4.51	4.52	20350	1750	9.00	9.00
Channel Bandwidth 15MHz				Channel Bandwidth 20MHz			
Channel	Frequency (MHz)	Occupied Bandwidth (MHz)		Channel	Frequency (MHz)	Occupied Bandwidth (MHz)	
		QPSK	16QAM			QPSK	16QAM
20025	1717.5	13.47	13.44	20050	1720	17.92	17.88
20175	1732.5	13.44	13.44	20175	1732.5	17.88	17.84
20325	1747.5	13.50	13.44	20300	1745	18.00	17.92

Spectrum Plot of Worst Value

1.4MHz / 16QAM

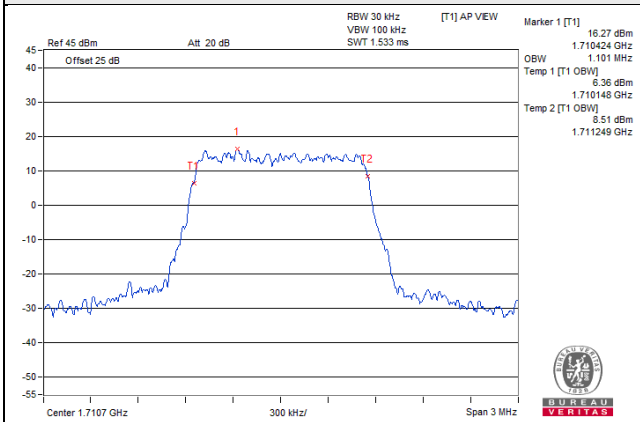

3MHz / QPSK

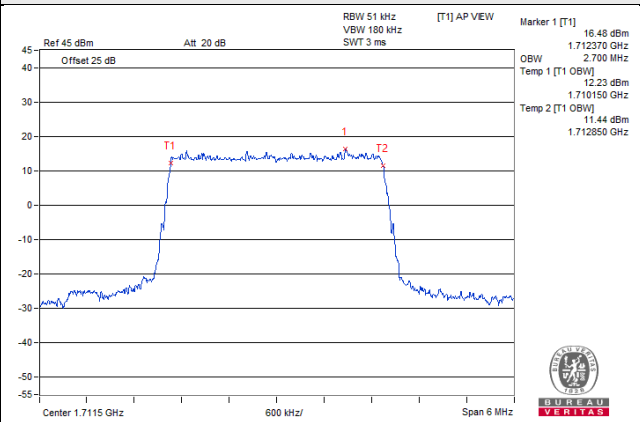

5MHz / 16QAM

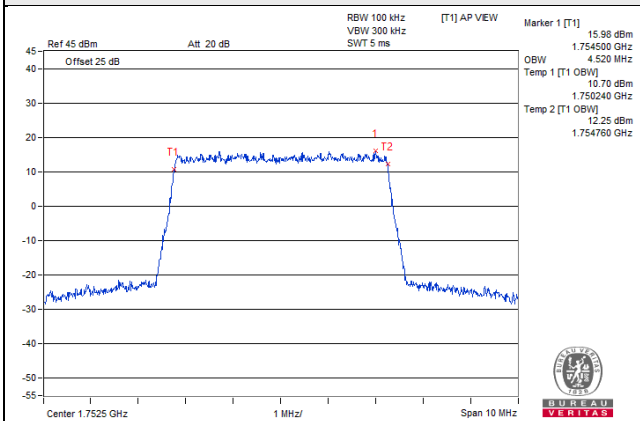

10MHz / QPSK

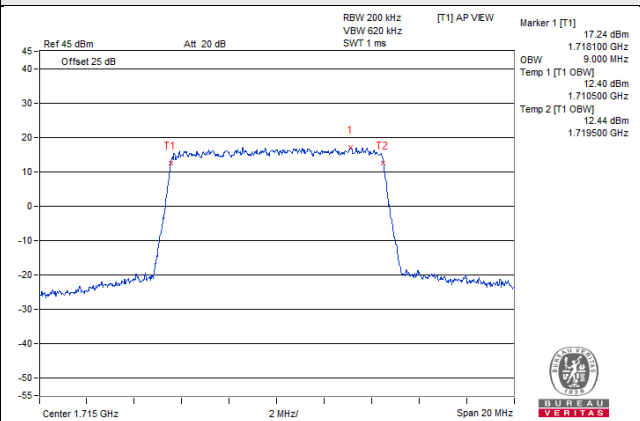

15MHz / QPSK

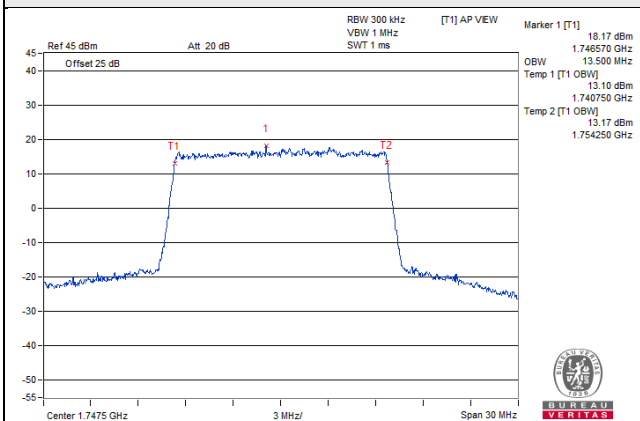

20MHz / QPSK

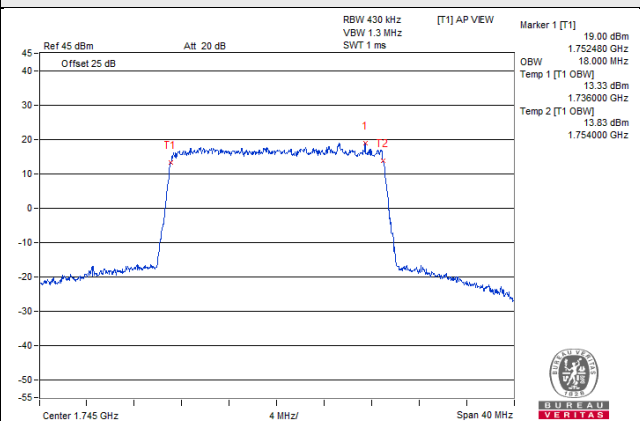

LTE Band 12							
Channel Bandwidth 1.4MHz				Channel Bandwidth 3MHz			
Channel	Frequency (MHz)	Occupied Bandwidth (MHz)		Channel	Frequency (MHz)	Occupied Bandwidth (MHz)	
		QPSK	16QAM			QPSK	16QAM
23017	699.7	1.09	1.10	23025	700.5	2.70	2.68
23095	707.5	1.09	1.10	23095	707.5	2.70	2.69
23173	715.3	1.09	1.09	23165	714.5	2.70	2.68
Channel Bandwidth 5MHz				Channel Bandwidth 10MHz			
Channel	Frequency (MHz)	Occupied Bandwidth (MHz)		Channel	Frequency (MHz)	Occupied Bandwidth (MHz)	
		QPSK	16QAM			QPSK	16QAM
23035	701.5	4.51	4.50	23060	704	8.98	8.96
23095	707.5	4.51	4.51	23095	707.5	9.02	9.00
23155	713.5	4.49	4.50	23130	711	8.96	8.94

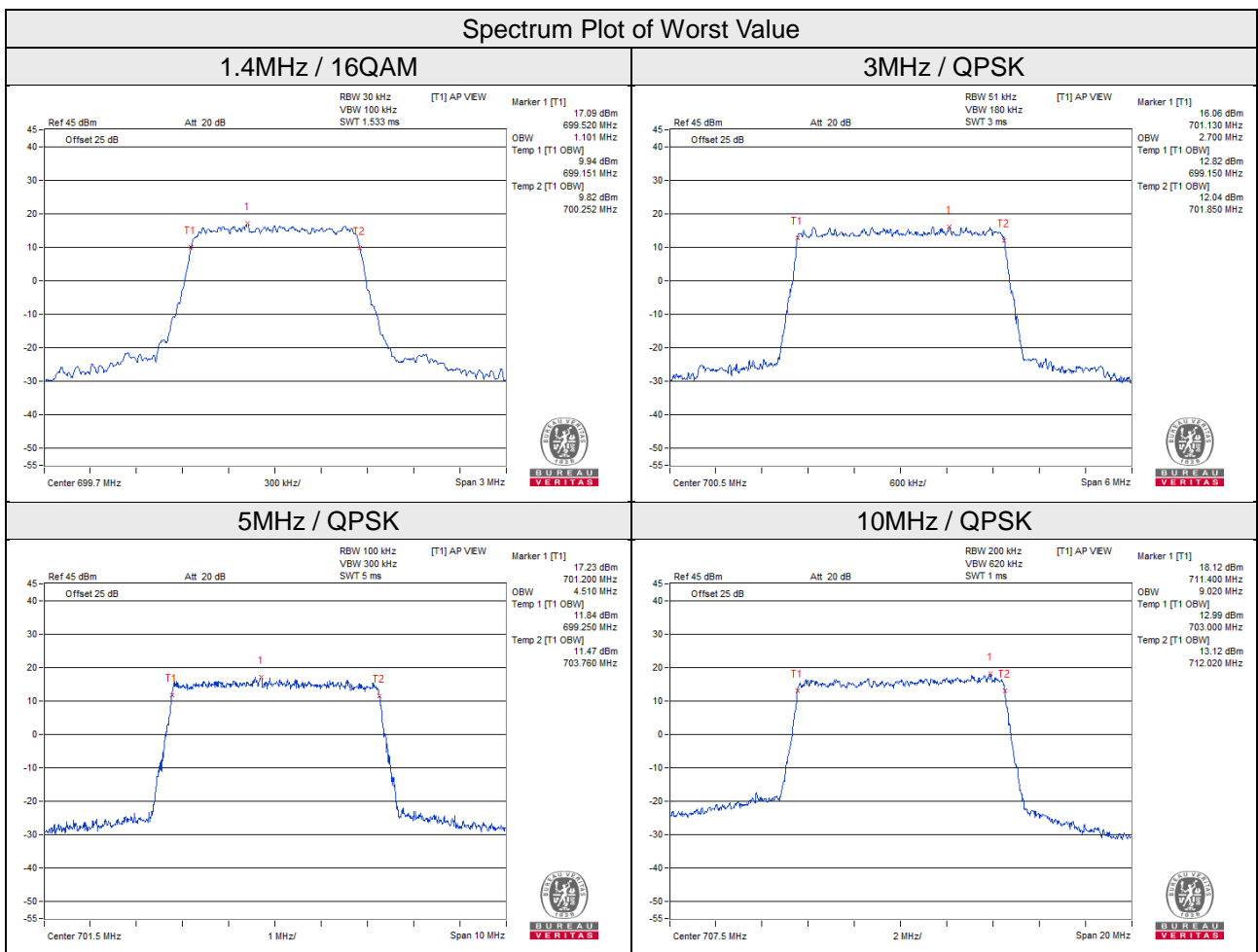

LTE Band 13

Channel Bandwidth 5MHz				Channel Bandwidth 10MHz			
Channel	Frequency (MHz)	Occupied Bandwidth (MHz)		Channel	Frequency (MHz)	Occupied Bandwidth (MHz)	
		QPSK	16QAM			QPSK	16QAM
23205	779.5	4.51	4.50	23230	782	8.96	8.94
23230	782	4.49	4.51				
23255	784.5	4.52	4.51				

Spectrum Plot of Worst Value

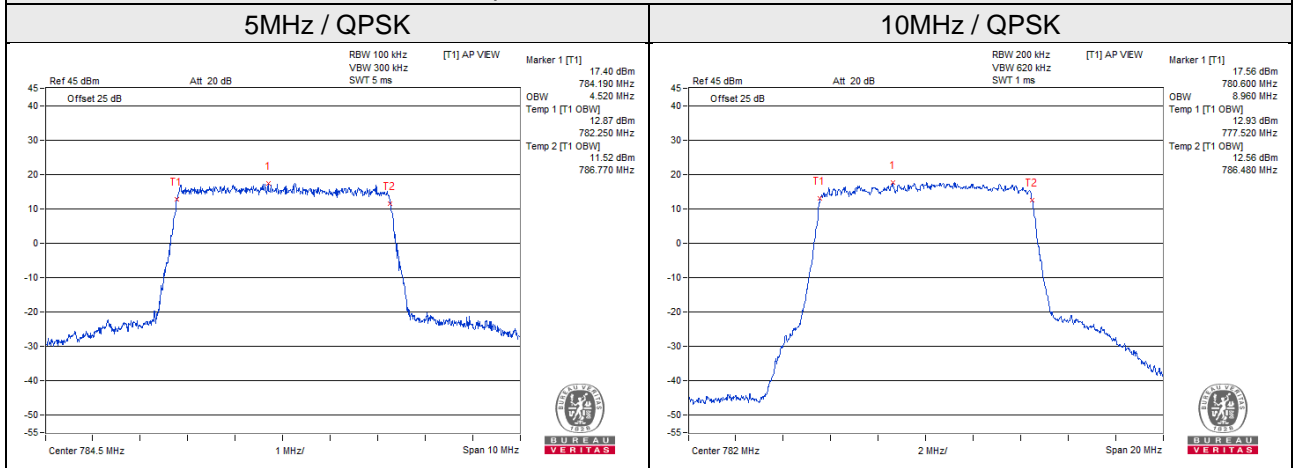

4.5 Channel Edge Measurement

4.5.1 Limits of Channel Edge Measurement

For Subpart L : LTE Band 4

According to FCC 27.53(h) AWS emission limits— General protection levels. Except as otherwise specified below, for operations in the 1695-1710 MHz, 1710-1755 MHz, 1755-1780 MHz, 1915-1920 MHz, 1995-2000 MHz, 2000-2020 MHz, 2110-2155 MHz, 2155-2180 MHz, and 2180-2200 bands, the power of any emission outside a licensee's frequency block shall be attenuated below the transmitter power (P) in watts by at least $43 + 10 \log_{10}(P)$ dB.

For Subpart H : LTE Band 12

According to FCC 27.53(g) For operations in the 600 MHz band and the 698-746 MHz band, the power of any emission outside a licensee's frequency band(s) of operation shall be attenuated below the transmitter power (P) within the licensed band(s) of operation, measured in watts, by at least $43 + 10 \log(P)$ dB. Compliance with this provision is based on the use of measurement instrumentation employing a resolution bandwidth of 100 kilohertz or greater. However, in the 100 kilohertz bands immediately outside and adjacent to a licensee's frequency block, a resolution bandwidth of at least 30 kHz may be employed.

For Subpart F : LTE Band 13

According to FCC 27.53 (c) For operations in the 746-758 MHz band and the 776-788 MHz band, the power of any emission outside the licensee's frequency band(s) of operation shall be attenuated below the transmitter power (P) within the licensed band(s) of operation, measured in watts, in accordance with the following:

- (1) On any frequency outside the 746-758 MHz band, the power of any emission shall be attenuated outside the band below the transmitter power (P) by at least $43 + 10 \log(P)$ dB;
- (2) On any frequency outside the 776-788 MHz band, the power of any emission shall be attenuated outside the band below the transmitter power (P) by at least $43 + 10 \log(P)$ dB;
- (3) On all frequencies between 763-775 MHz and 793-805 MHz, by a factor not less than $76 + 10 \log(P)$ dB in a 6.25 kHz band segment, for base and fixed stations;
- (4) On all frequencies between 763-775 MHz and 793-805 MHz, by a factor not less than $65 + 10 \log(P)$ dB in a 6.25 kHz band segment, for mobile and portable stations;
- (5) Compliance with the provisions of paragraphs (c)(1) and (c)(2) of this section is based on the use of measurement instrumentation employing a resolution bandwidth of 100 kHz or greater. However, in the 100 kHz bands immediately outside and adjacent to the frequency block, a resolution bandwidth of at least 30 kHz may be employed;
- (6) Compliance with the provisions of paragraphs (c)(3) and (c)(4) of this section is based on the use of measurement instrumentation such that the reading taken with any resolution bandwidth setting should be adjusted to indicate spectral energy in a 6.25 kHz segment.

According to FCC 27.53(f) For operations in the 746–758 MHz, 775–788 MHz, and 805–806 MHz bands, emissions in the band 1559–1610 MHz shall be limited to -70 dBW/MHz equivalent isotropically radiated power (EIRP) for wideband signals, and -80 dBW EIRP for discrete emissions of less than 700 Hz bandwidth.

4.5.2 Test Setup

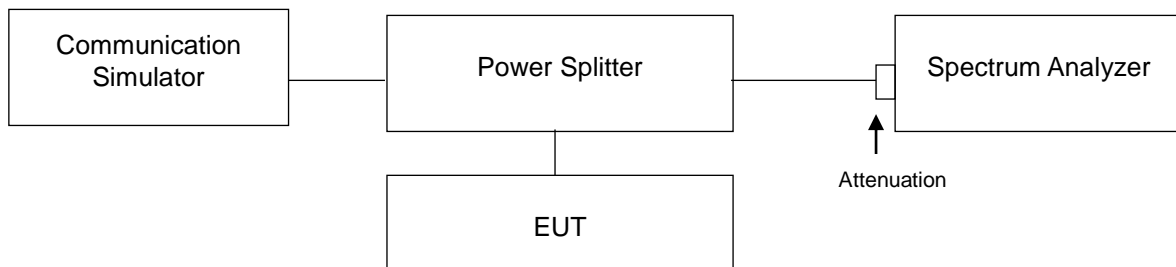

4.5.3 Test Procedures

- a. All measurements were done at low and high operational frequency range.
- b. The center frequency of spectrum is the band edge frequency and s RB of the spectrum is >1% emission bandwidth and VB of the spectrum is $\geq 3*RB$.
- c. Record the max trace plot into the test report.

4.5.4 Test Results

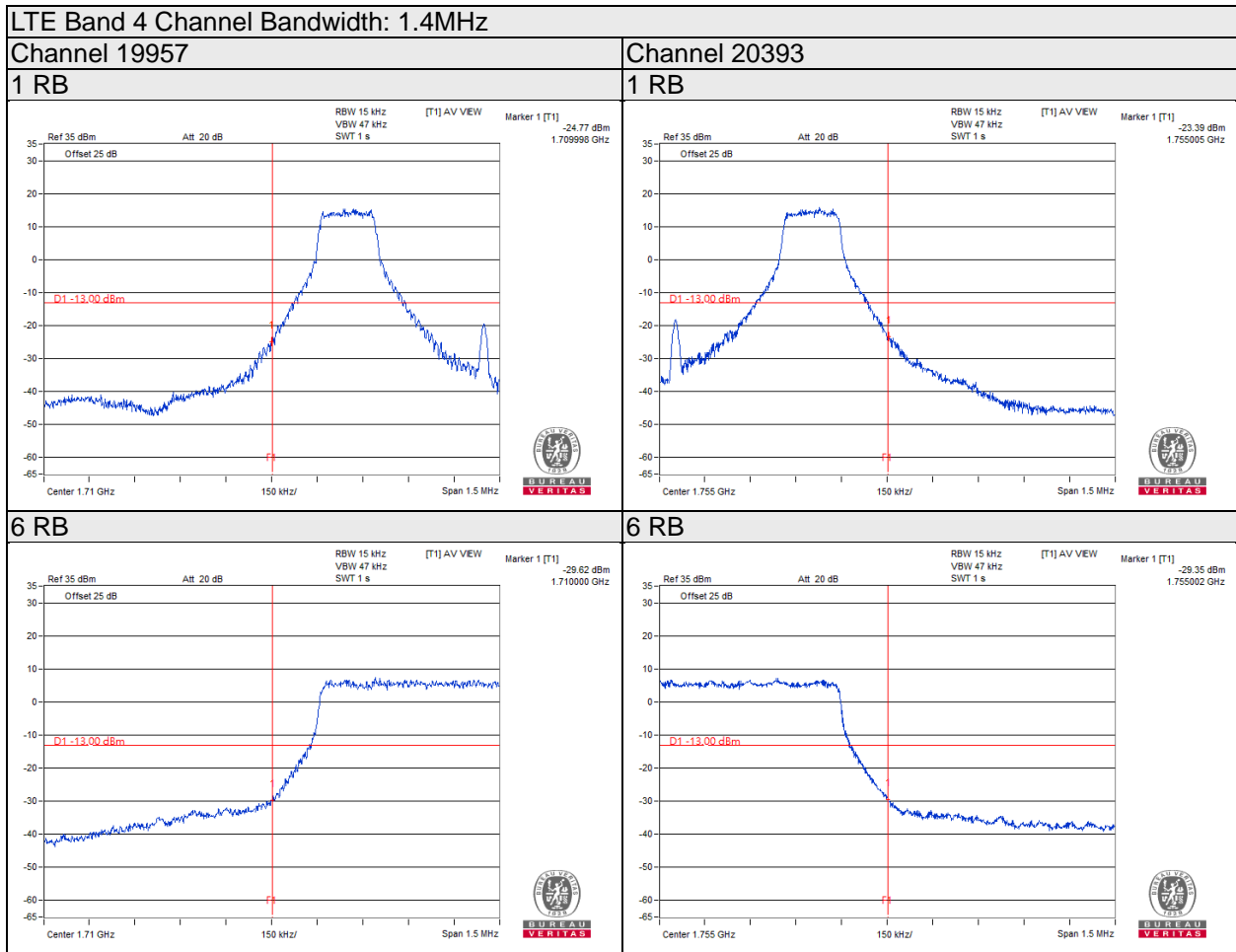

LTE Band 4 Channel Bandwidth: 3MHz

Channel 19965

1 RB

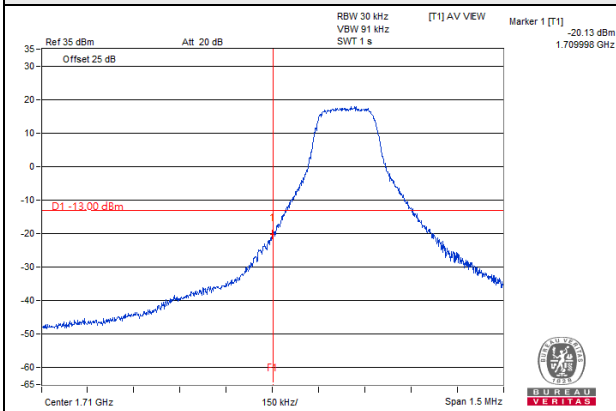

Channel 20385

1 RB

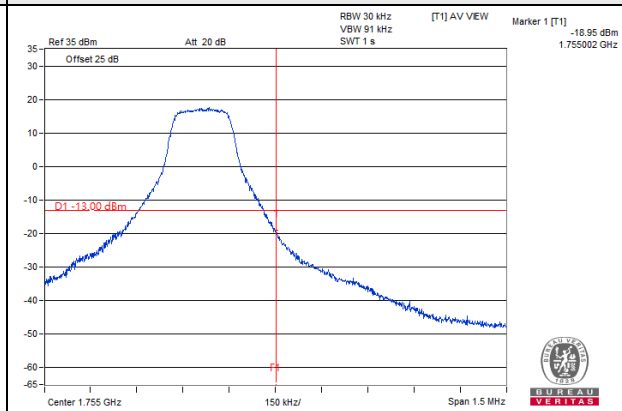

15 RB

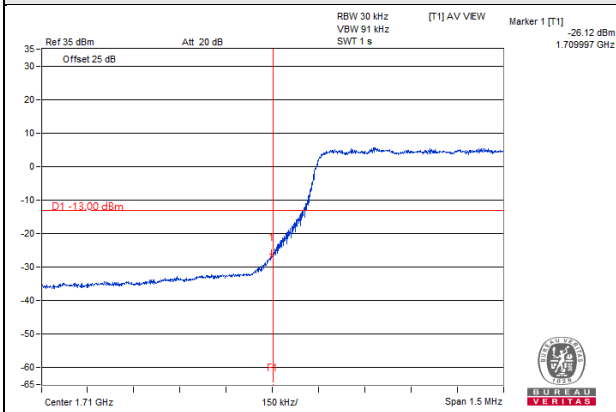

15 RB

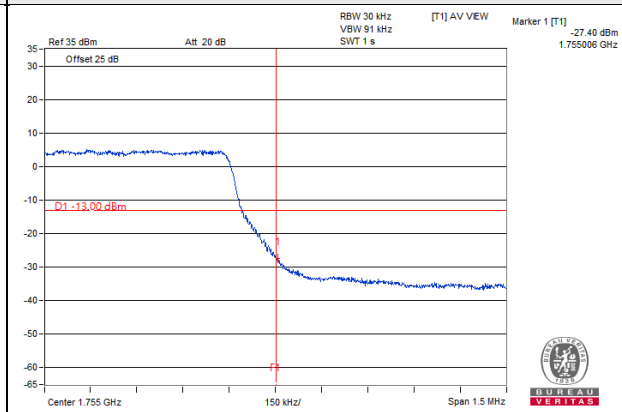

LTE Band 4 Channel Bandwidth: 5MHz

Channel 19975

1 RB

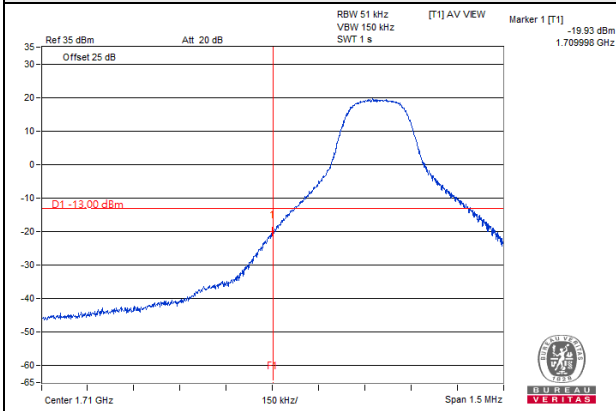

Channel 20375

1 RB

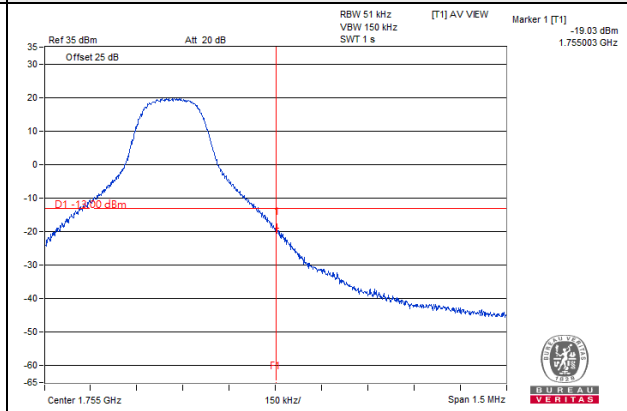

25 RB

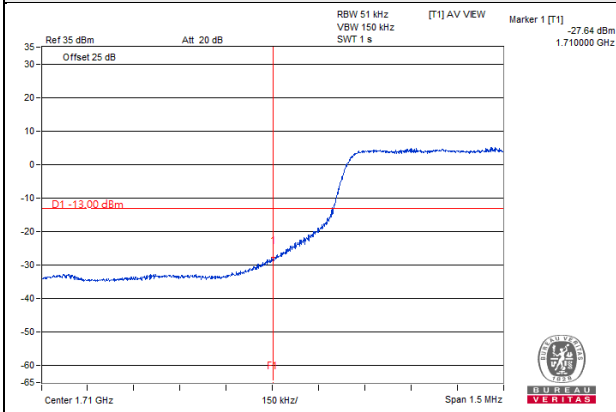

25 RB

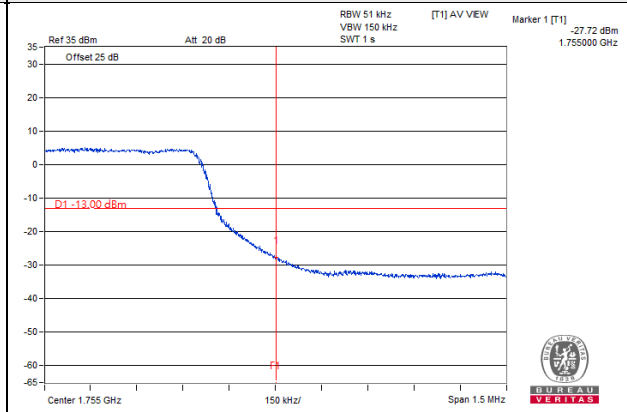

LTE Band 4 Channel Bandwidth: 10MHz

Channel 20000

1 RB

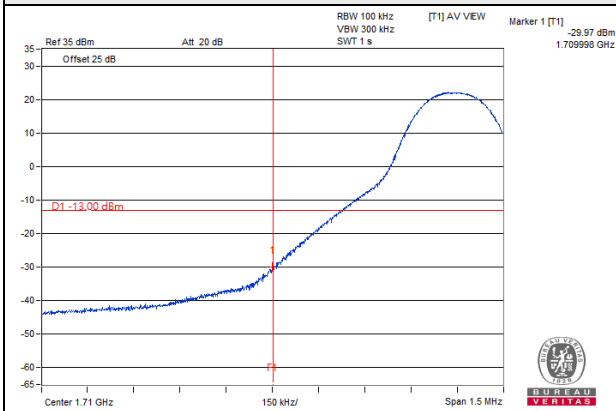

Channel 20350

1 RB

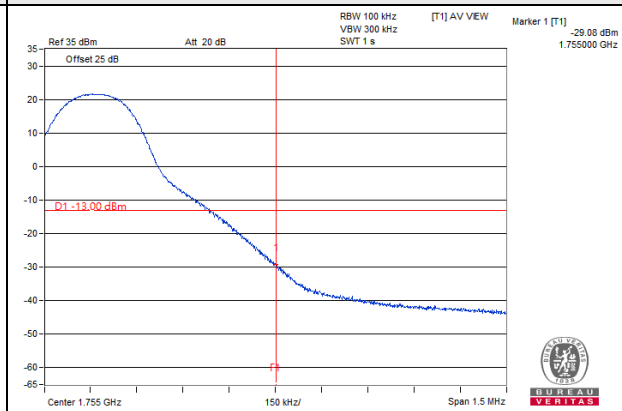

50 RB

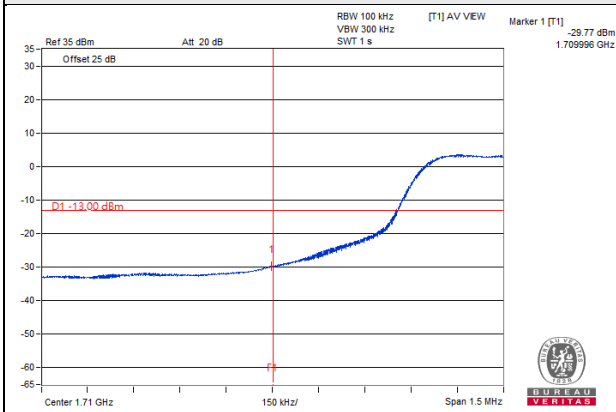

50 RB

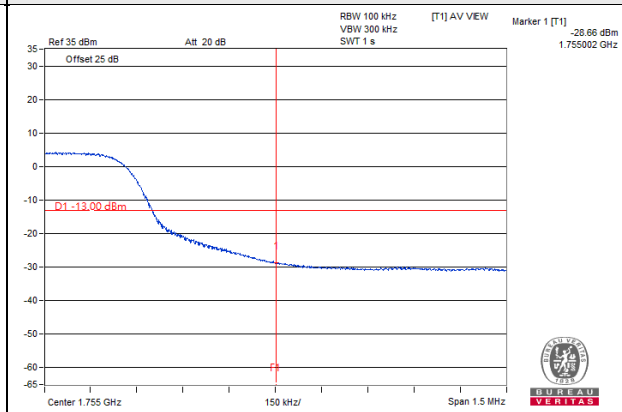

LTE Band 4 Channel Bandwidth: 15MHz

Channel 20025

1 RB

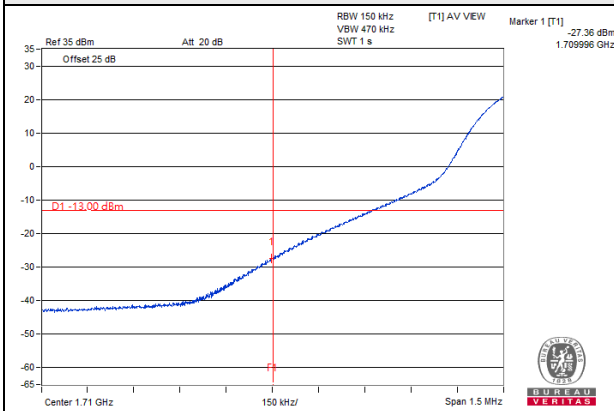

Channel 20325

1 RB

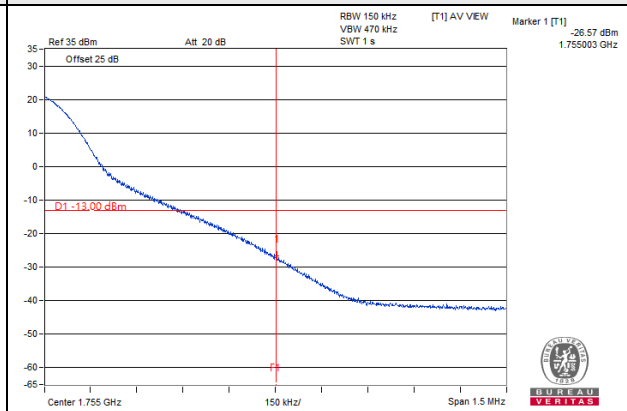

75 RB

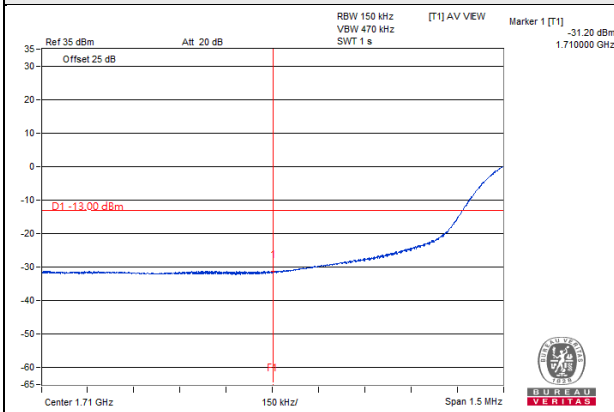

75 RB

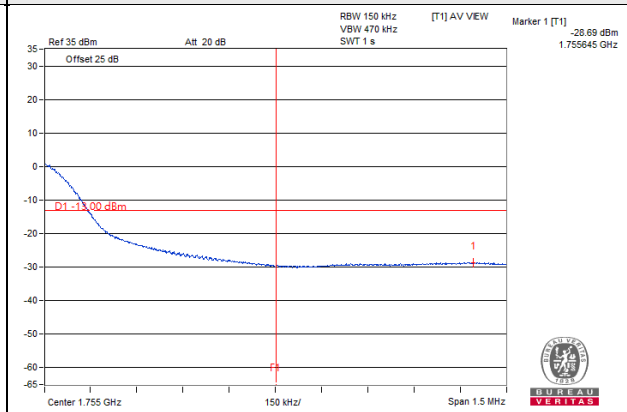

LTE Band 4 Channel Bandwidth: 20MHz

Channel 20050

1 RB

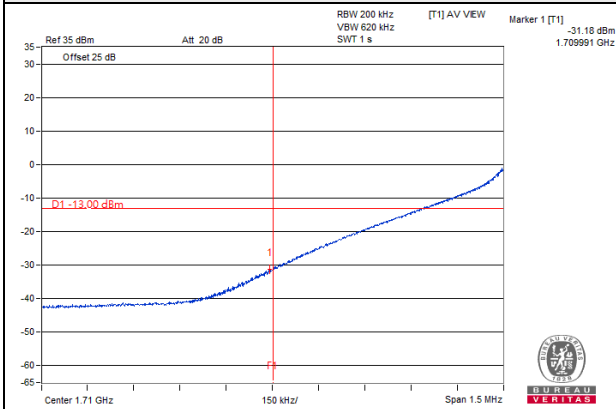

Channel 20300

1 RB

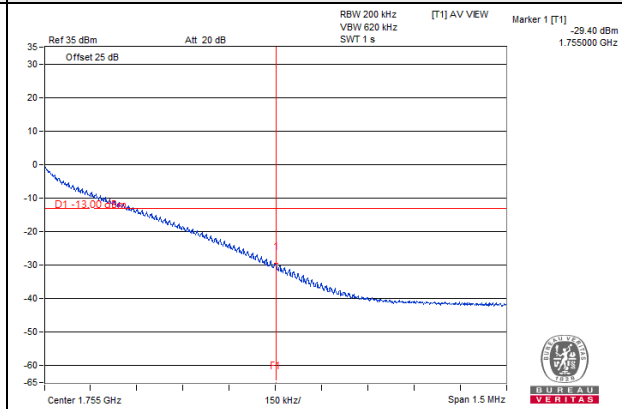

100 RB

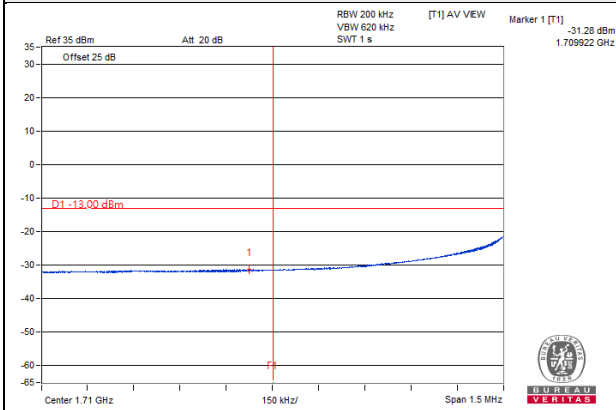

100 RB

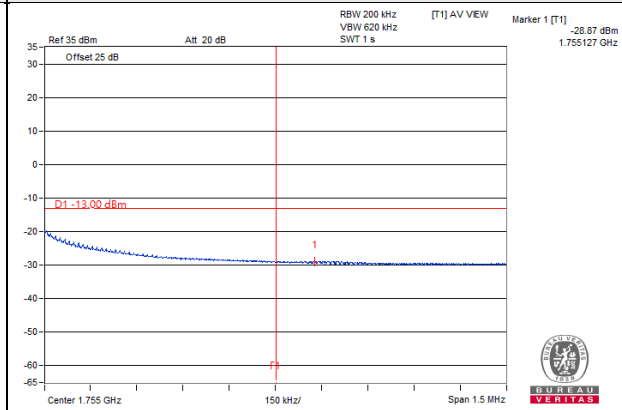

LTE Band 12 Channel Bandwidth: 1.4MHz

Channel 23017

1 RB

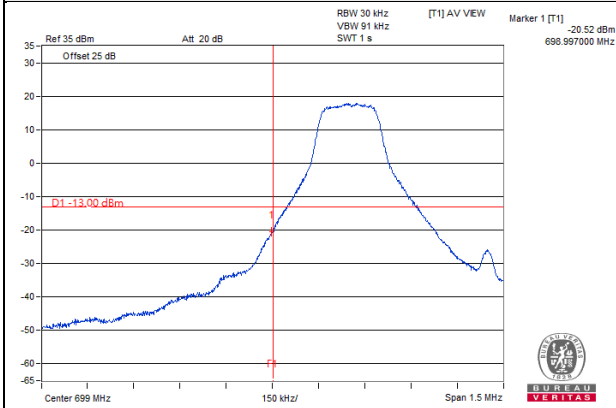

Channel 23173

1 RB

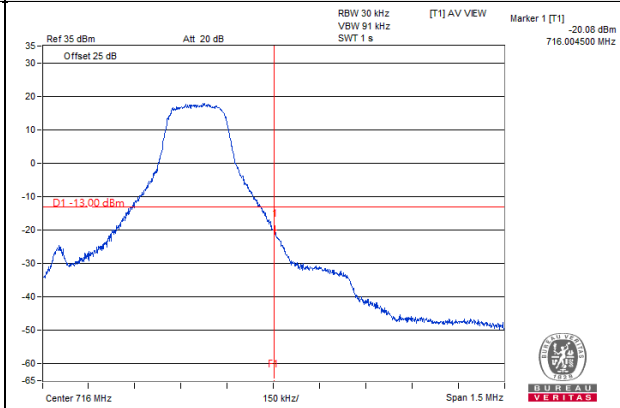

6 RB

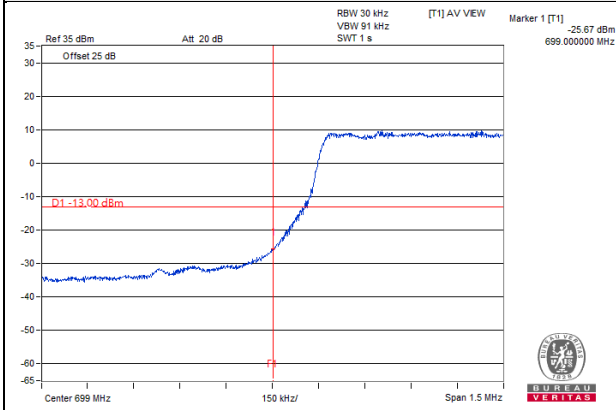

6 RB

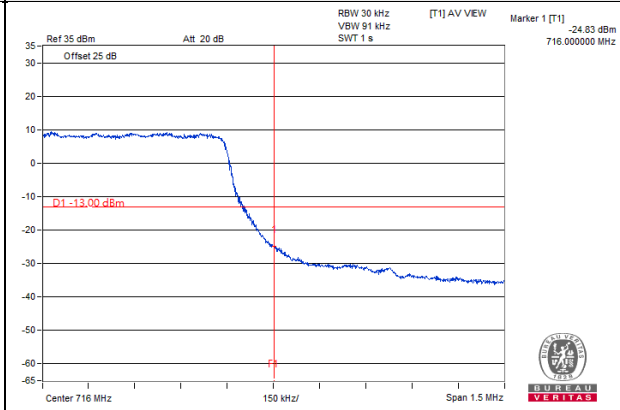

LTE Band 12 Channel Bandwidth: 3MHz

Channel 23025

1 RB

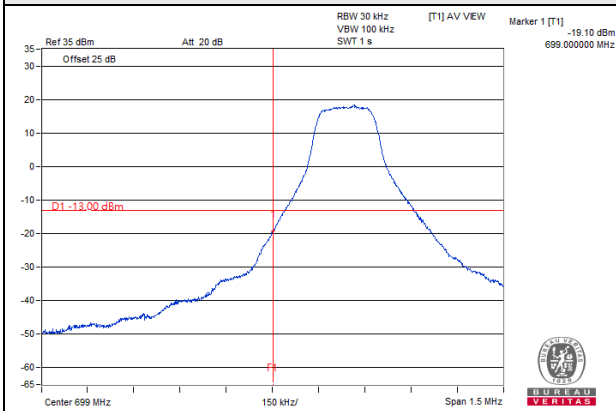

Channel 23165

1 RB

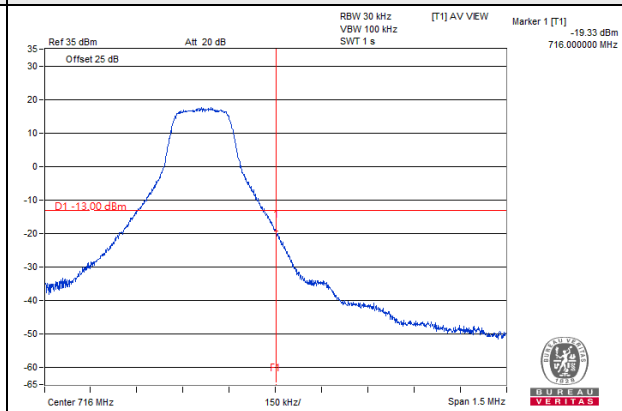

15 RB

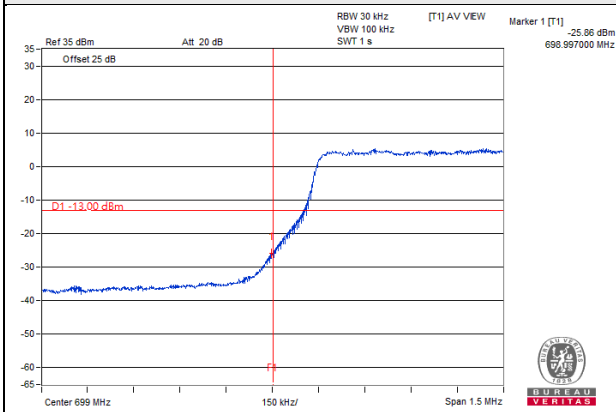

15 RB

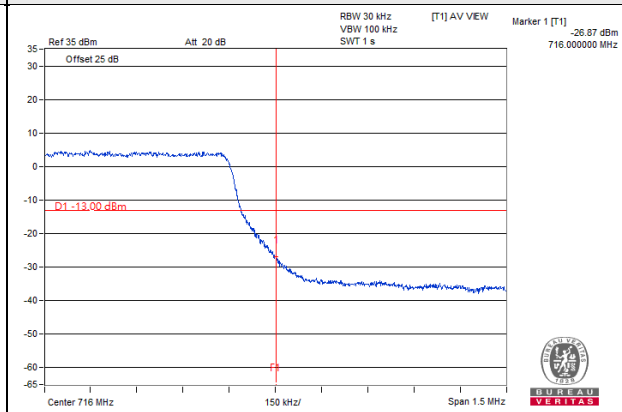

LTE Band 12 Channel Bandwidth: 5MHz

Channel 23035

1 RB

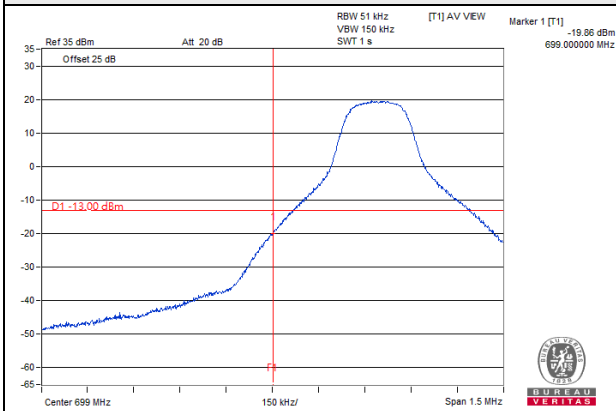

Channel 23155

1 RB

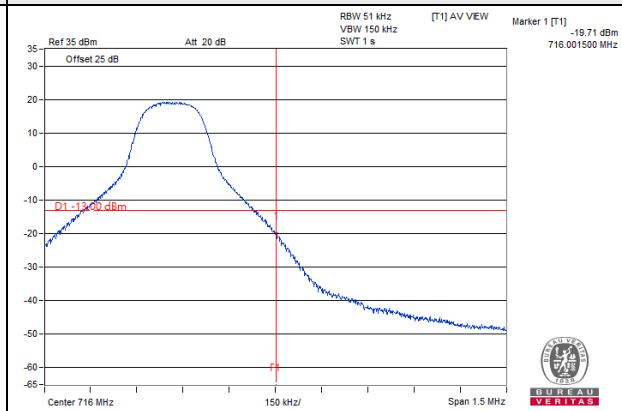

25 RB

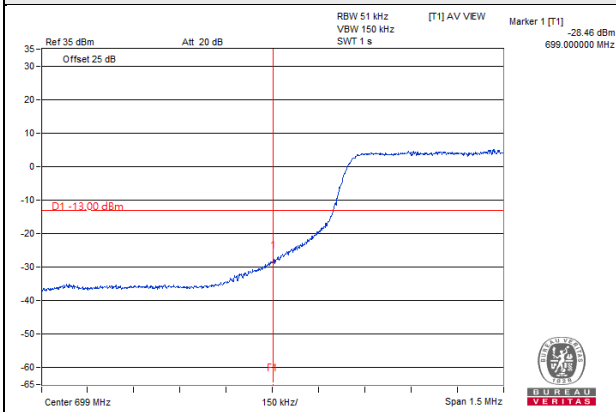

25 RB

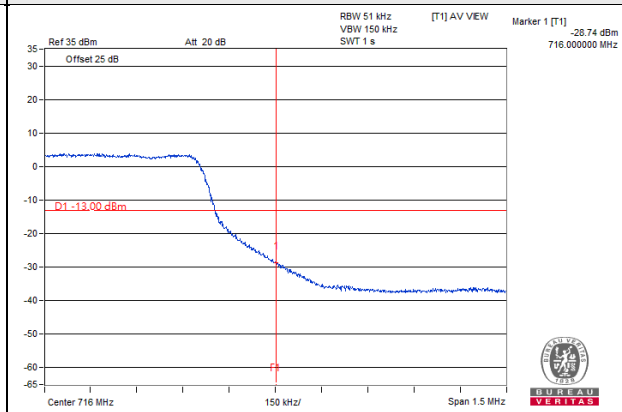

LTE Band 12 Channel Bandwidth: 10MHz

Channel 23060

1 RB

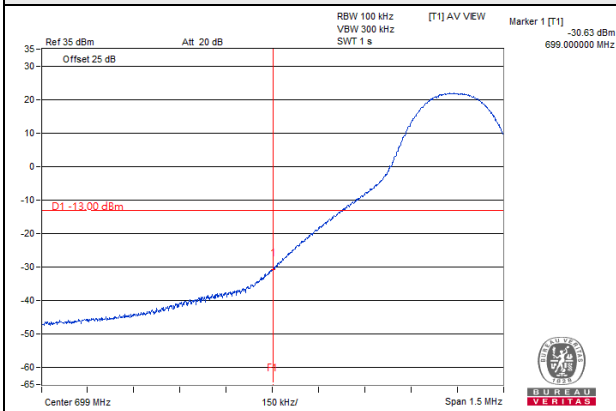

Channel 23130

1 RB

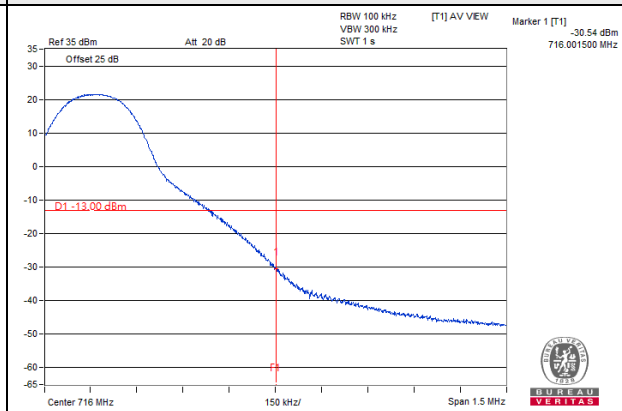

50 RB

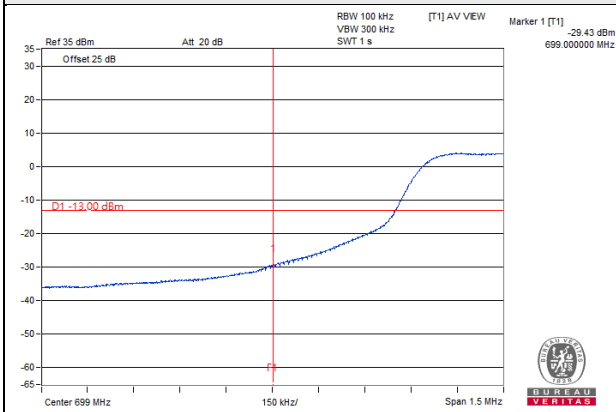

50 RB

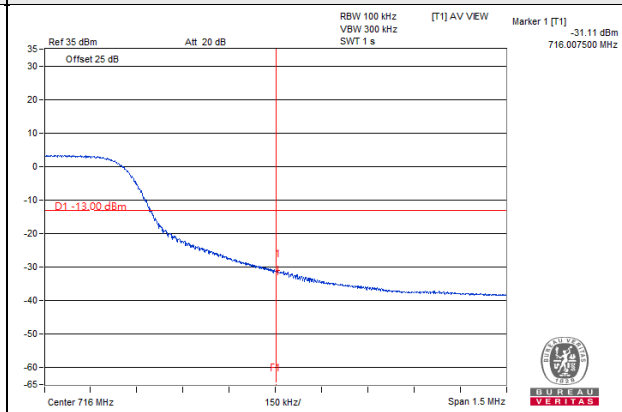

LTE Band 13 Channel Bandwidth: 5MHz

Channel 23205

1 RB

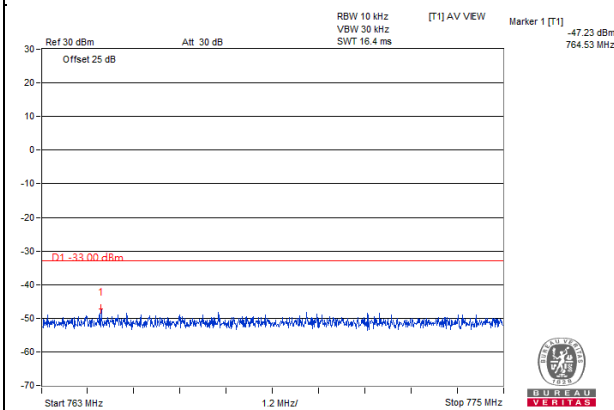
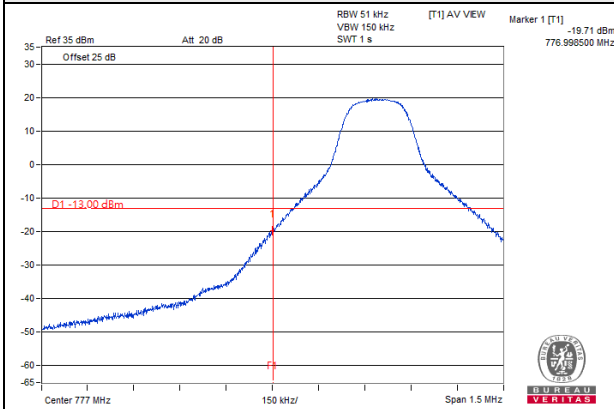

Channel 23255

1 RB

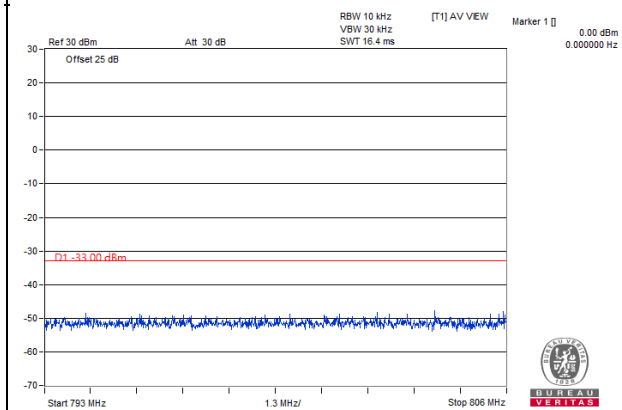
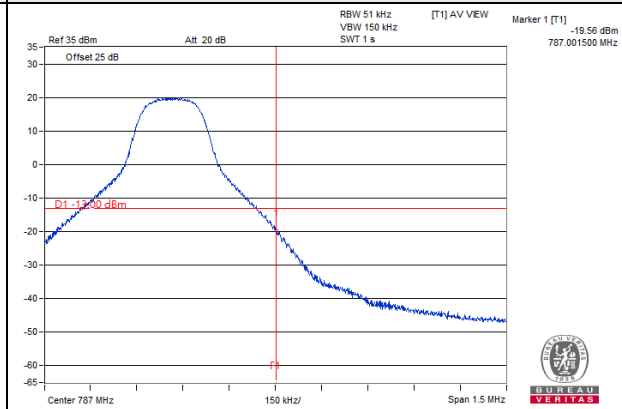

25 RB

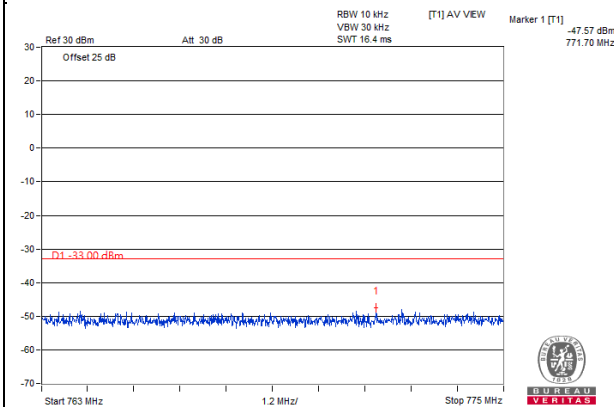
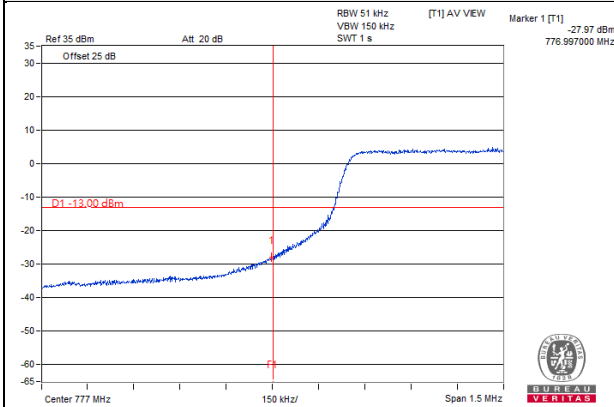

25 RB

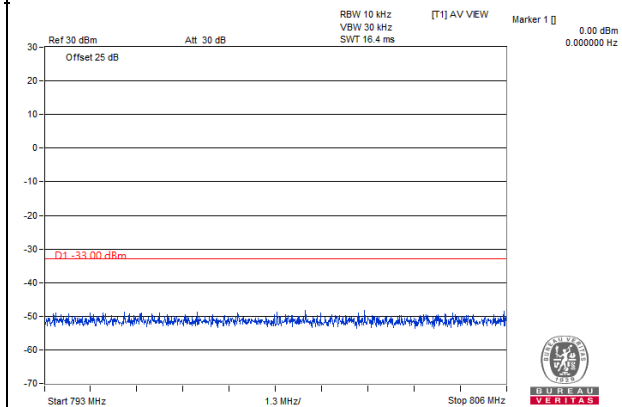
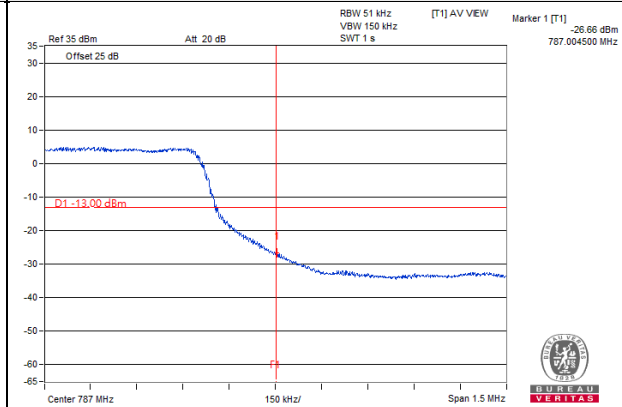

LTE Band 13 Channel Bandwidth: 10MHz

Channel 23230

1 RB

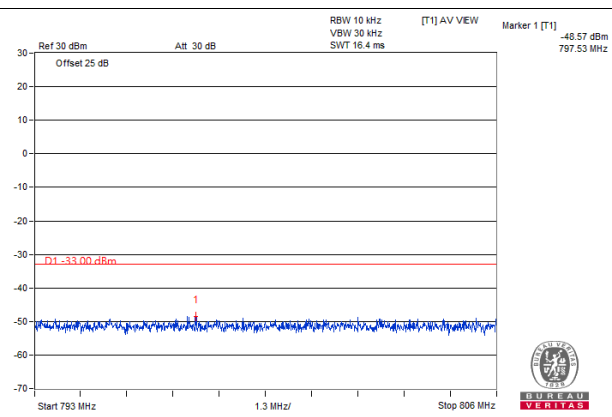
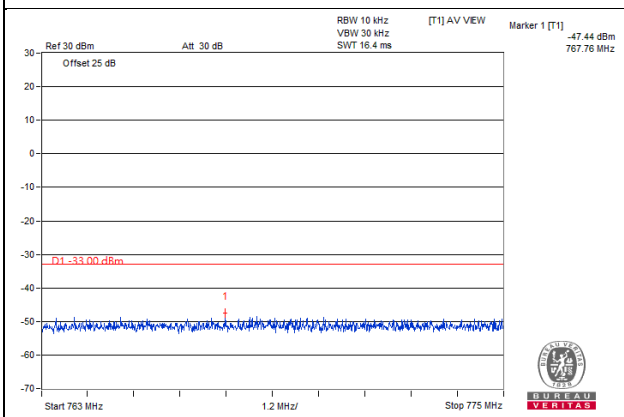
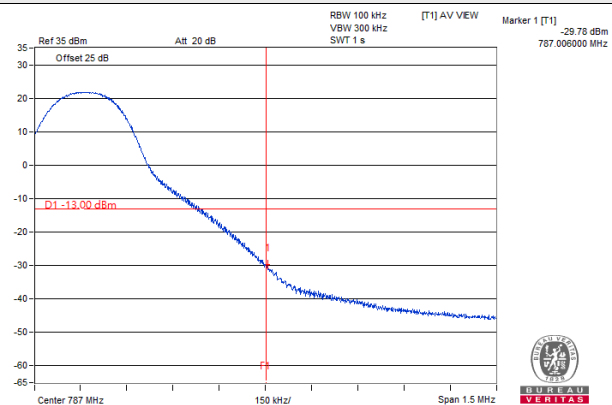
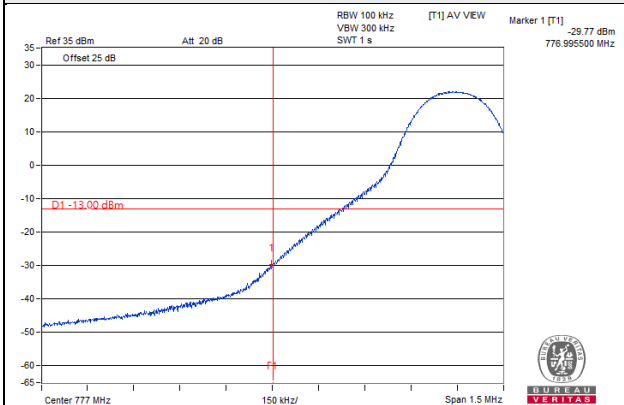

50 RB

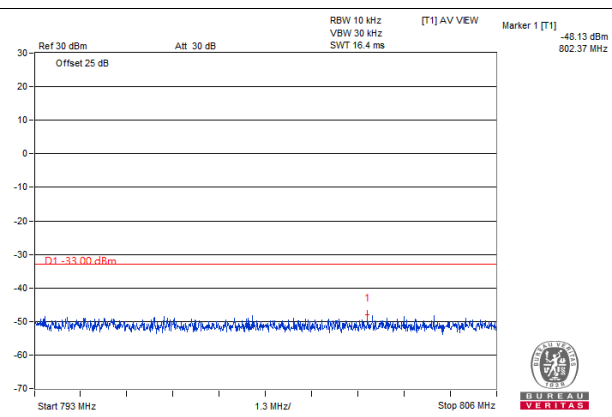
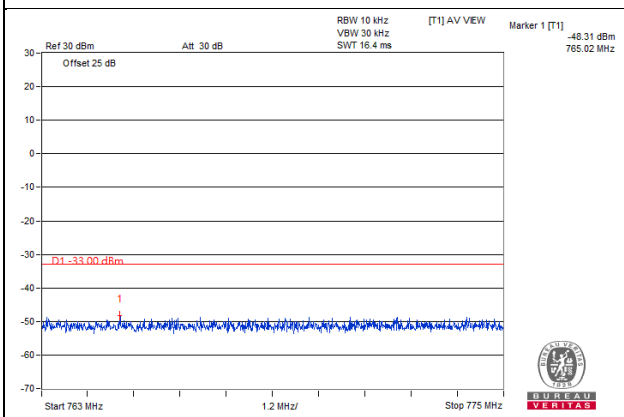
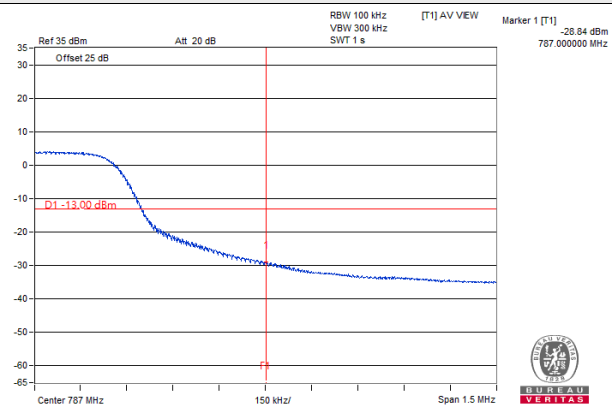
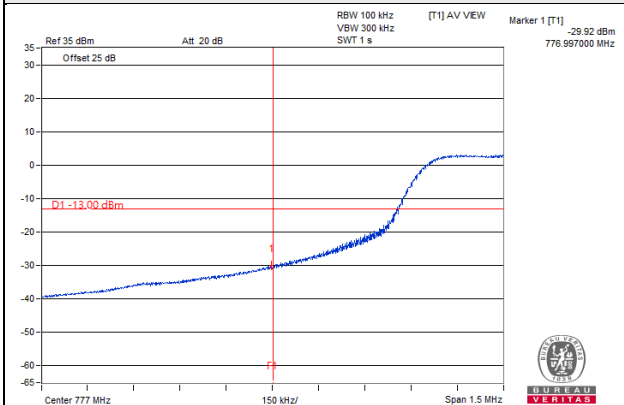

4.6 Peak to Average Ratio

4.6.1 Limits of Peak to Average Ratio Measurement

In measuring transmissions in this band using an average power technique, the peak to-average ratio (PAR) of the transmission may not exceed 13 dB

4.6.2 Test Setup

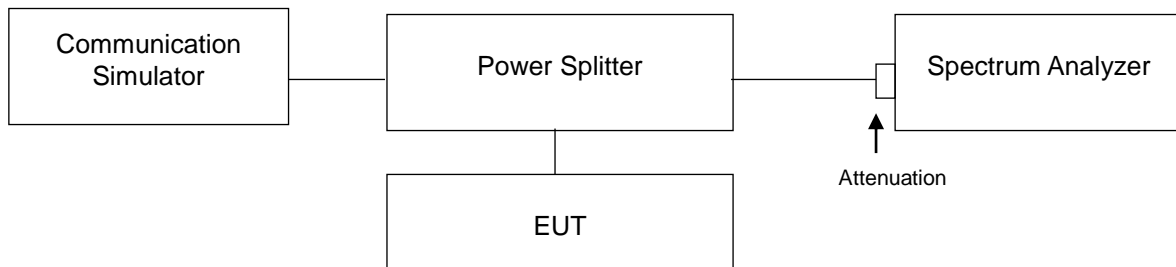

4.6.3 Test Procedures

1. Set resolution/measurement bandwidth \geq signal's occupied bandwidth;
2. Set the number of counts to a value that stabilizes the measured CCDF curve;
3. Record the maximum PAPR level associated with a probability of 0.1%.

4.6.4 Test Results

LTE Band 4							
Channel Bandwidth 1.4MHz				Channel Bandwidth 3MHz			
Channel	Frequency (MHz)	Peak To Average Ratio (dB)		Channel	Frequency (MHz)	Peak To Average Ratio (dB)	
		QPSK	16QAM			QPSK	16QAM
19957	1710.7	5.42	6.23	19965	1711.5	5.47	6.39
20175	1732.5	5.45	6.26	20175	1732.5	5.45	6.35
20393	1754.3	5.39	6.24	20385	1753.5	5.47	6.41
Channel Bandwidth 5MHz				Channel Bandwidth 10MHz			
Channel	Frequency (MHz)	Peak To Average Ratio (dB)		Channel	Frequency (MHz)	Peak To Average Ratio (dB)	
		QPSK	16QAM			QPSK	16QAM
19975	1712.5	5.43	6.35	20000	1715	5.45	6.33
20175	1732.5	5.45	6.29	20175	1732.5	5.38	6.24
20375	1752.5	5.48	6.37	20350	1750	5.45	6.35
Channel Bandwidth 15MHz				Channel Bandwidth 20MHz			
Channel	Frequency (MHz)	Peak To Average Ratio (dB)		Channel	Frequency (MHz)	Peak To Average Ratio (dB)	
		QPSK	16QAM			QPSK	16QAM
20025	1717.5	5.62	6.30	20050	1720	5.42	6.28
20175	1732.5	5.54	6.25	20175	1732.5	5.45	6.22
20325	1747.5	5.64	6.35	20300	1745	5.47	6.32

Spectrum Plot of Worst Value

1.4MHz / 16QAM

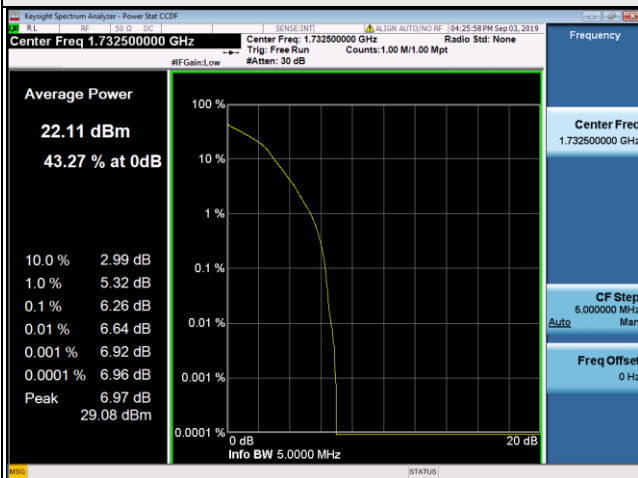

3MHz / 16QAM

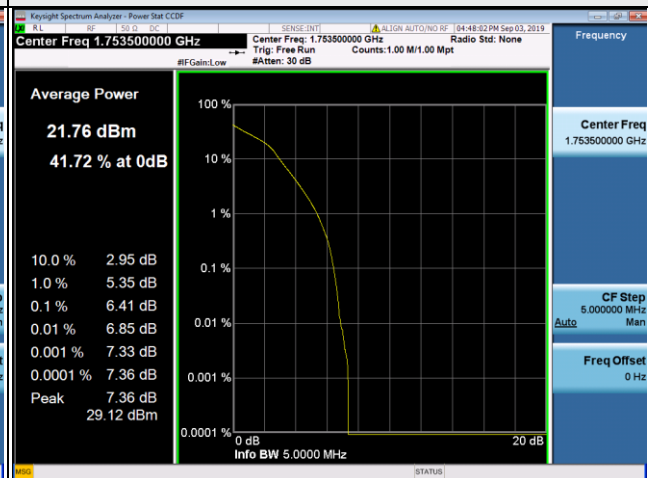

5MHz / 16QAM

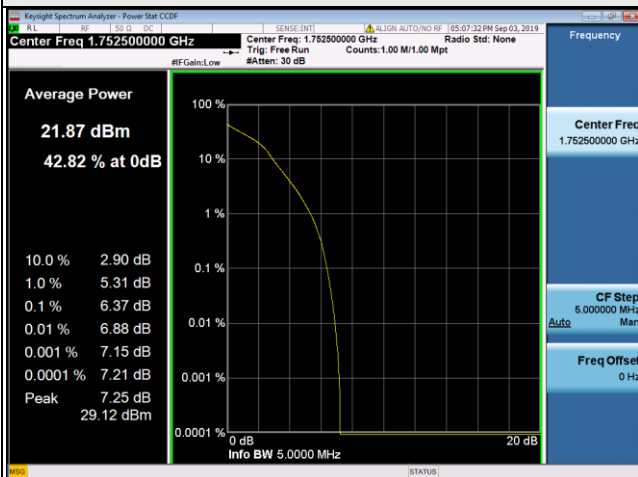

10MHz / 16QAM



15MHz / 16QAM

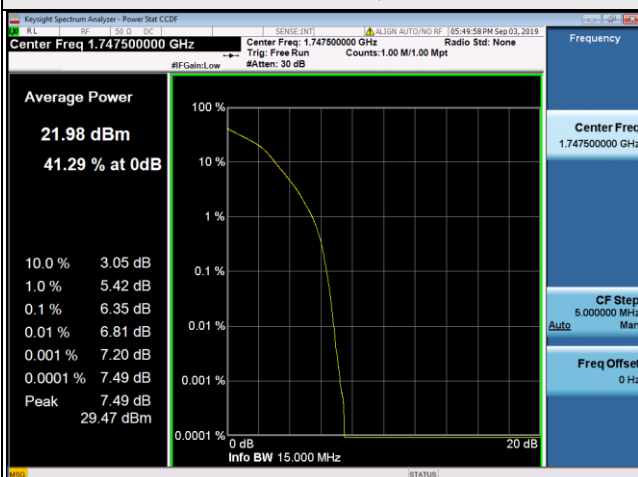

20MHz / 16QAM

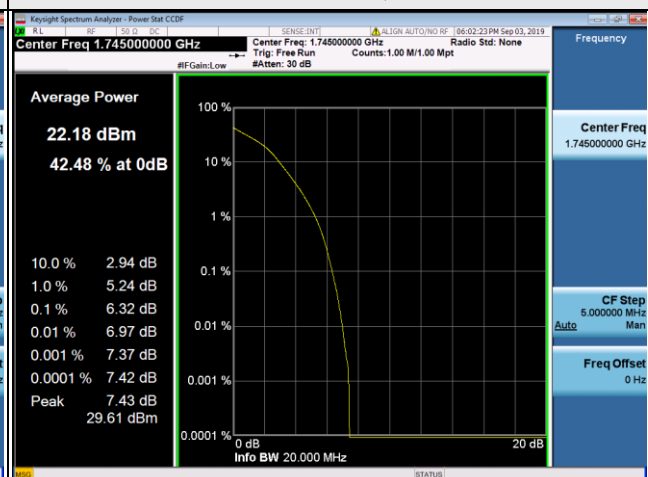

LTE Band 12							
Channel Bandwidth 1.4MHz				Channel Bandwidth 3MHz			
Channel	Frequency (MHz)	Peak To Average Ratio (dB)		Channel	Frequency (MHz)	Peak To Average Ratio (dB)	
		QPSK	16QAM			QPSK	16QAM
23017	699.7	4.95	5.74	23025	700.5	4.96	5.82
23095	707.5	5.01	5.77	23095	707.5	5.04	5.84
23173	715.3	4.79	5.58	23165	714.5	4.85	5.72
Channel Bandwidth 5MHz				Channel Bandwidth 10MHz			
Channel	Frequency (MHz)	Peak To Average Ratio (dB)		Channel	Frequency (MHz)	Peak To Average Ratio (dB)	
		QPSK	16QAM			QPSK	16QAM
23035	701.5	5.00	5.88	23060	704	5.07	5.88
23095	707.5	5.12	5.97	23095	707.5	5.2	6.01
23155	713.5	4.95	5.83	23130	711	4.87	5.80

Spectrum Plot of Worst Value



LTE Band 13							
Channel Bandwidth 5MHz				Channel Bandwidth 10MHz			
Channel	Frequency (MHz)	Peak To Average Ratio (dB)		Channel	Frequency (MHz)	Peak To Average Ratio (dB)	
		QPSK	16QAM			QPSK	16QAM
23205	779.5	4.99	5.85	23230	782	4.85	5.75
23230	782	4.91	5.78				
23255	784.5	4.92	5.74				

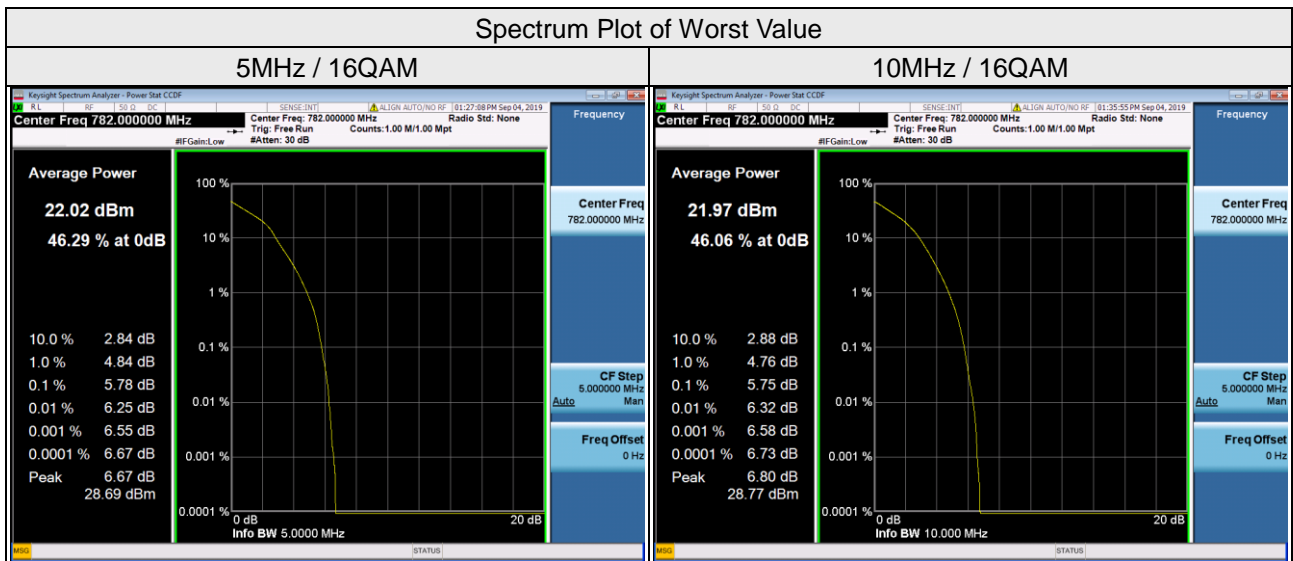

4.7 Conducted Spurious Emissions

4.7.1 Limits of Conducted Spurious Emissions Measurement

According to FCC 27.53(g) For operations in the 600 MHz band and the 698-746 MHz band, the power of any emission outside a licensee's frequency band(s) of operation shall be attenuated below the transmitter power (P) within the licensed band(s) of operation, measured in watts, by at least $43 + 10 \log (P)$ dB. Compliance with this provision is based on the use of measurement instrumentation employing a resolution bandwidth of 100 kilohertz or greater. However, in the 100 kilohertz bands immediately outside and adjacent to a licensee's frequency block, a resolution bandwidth of at least 30 kHz may be employed.

According to FCC 27.53(h) AWS emission limits— General protection levels. Except as otherwise specified below, for operations in the 1695-1710 MHz, 1710-1755 MHz, 1755-1780 MHz, 1915-1920 MHz, 1995-2000 MHz, 2000-2020 MHz, 2110-2155 MHz, 2155-2180 MHz, and 2180-2200 bands, the power of any emission outside a licensee's frequency block shall be attenuated below the transmitter power (P) in watts by at least $43 + 10 \log_{10} (P)$ dB.

According to FCC 27.53 (c) For operations in the 746-758 MHz band and the 776-788 MHz band, the power of any emission outside the licensee's frequency band(s) of operation shall be attenuated below the transmitter power (P) within the licensed band(s) of operation, measured in watts, in accordance with the following:

- (1) On any frequency outside the 746-758 MHz band, the power of any emission shall be attenuated outside the band below the transmitter power (P) by at least $43 + 10 \log (P)$ dB;
- (2) On any frequency outside the 776-788 MHz band, the power of any emission shall be attenuated outside the band below the transmitter power (P) by at least $43 + 10 \log (P)$ dB;
- (3) On all frequencies between 763-775 MHz and 793-805 MHz, by a factor not less than $76 + 10 \log (P)$ dB in a 6.25 kHz band segment, for base and fixed stations;
- (4) On all frequencies between 763-775 MHz and 793-805 MHz, by a factor not less than $65 + 10 \log (P)$ dB in a 6.25 kHz band segment, for mobile and portable stations;
- (5) Compliance with the provisions of paragraphs (c)(1) and (c)(2) of this section is based on the use of measurement instrumentation employing a resolution bandwidth of 100 kHz or greater. However, in the 100 kHz bands immediately outside and adjacent to the frequency block, a resolution bandwidth of at least 30 kHz may be employed;
- (6) Compliance with the provisions of paragraphs (c)(3) and (c)(4) of this section is based on the use of measurement instrumentation such that the reading taken with any resolution bandwidth setting should be adjusted to indicate spectral energy in a 6.25 kHz segment.

According to FCC 27.53(f) For operations in the 746–758 MHz, 775–788 MHz, and 805–806 MHz bands, emissions in the band 1559–1610 MHz shall be limited to -70 dBW/MHz equivalent isotropically radiated power (EIRP) for wideband signals, and -80 dBW EIRP for discrete emissions of less than 700 Hz bandwidth.

4.7.2 Test Setup

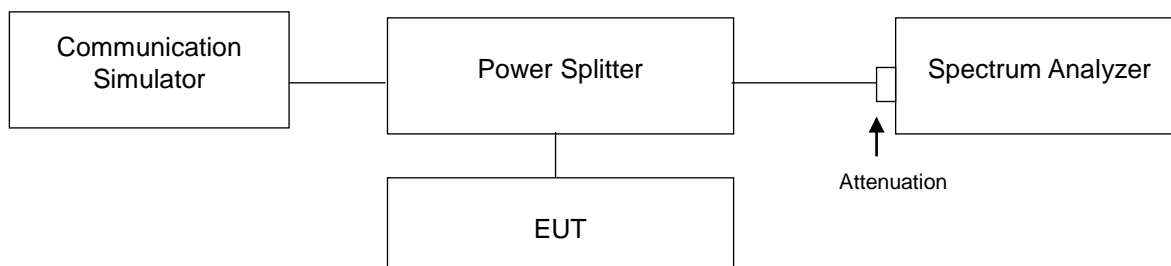

4.7.3 Test Procedure

- a. All measurements were done at 3 channels: low, middle and high operational frequency range.
- b. When the spectrum scanned from 9 kHz to the tenth harmonic of the highest fundamental frequency, it shall be connected to the 20dB pad attenuated the carried frequency.

4.7.4 Test Results

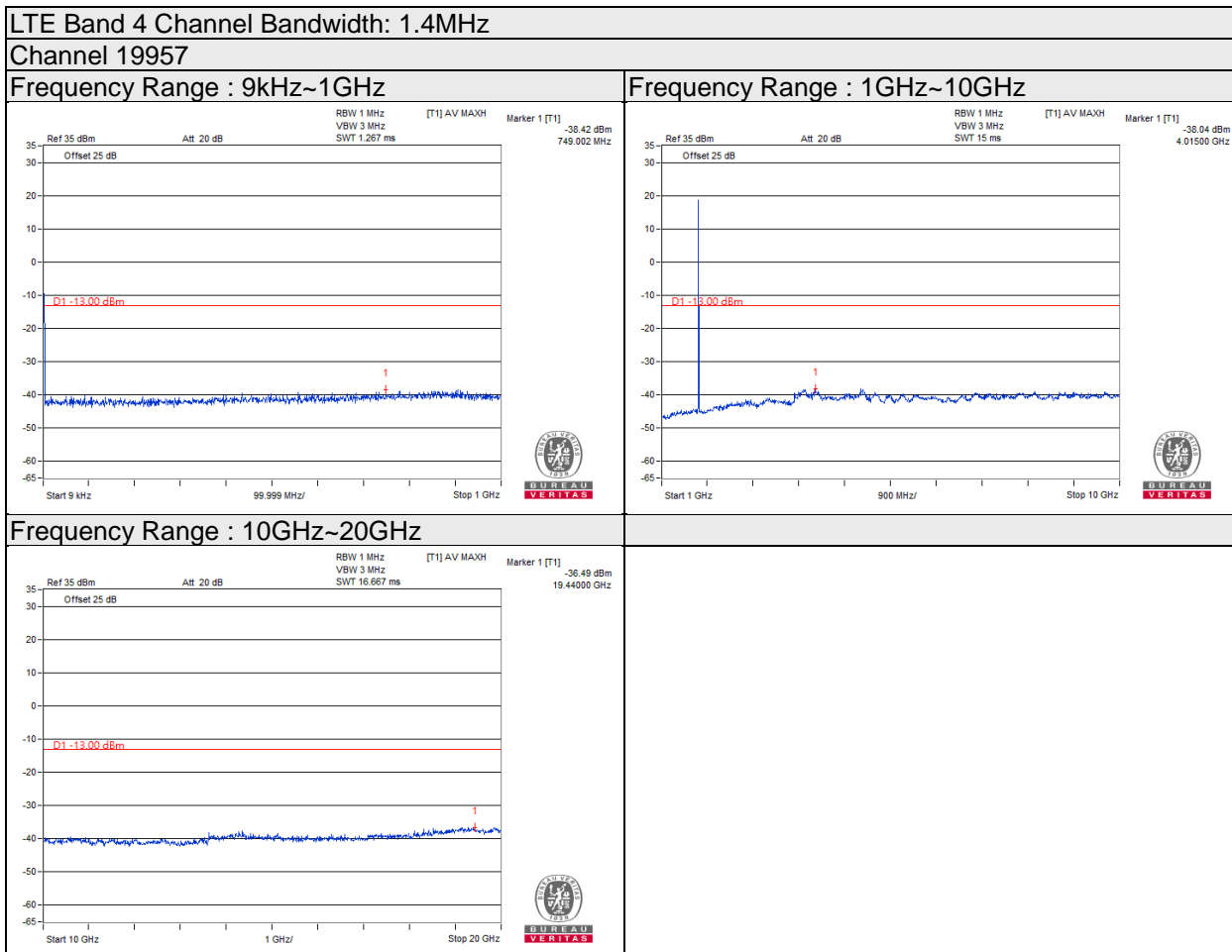

Note: The signal of 9kHz is IF signal from test instrument.

LTE Band 4 Channel Bandwidth: 1.4MHz

Channel 20175

Frequency Range : 9kHz~1GHz

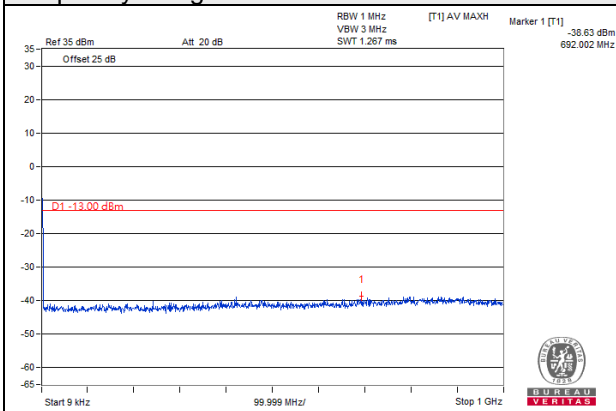

Frequency Range : 1GHz~10GHz

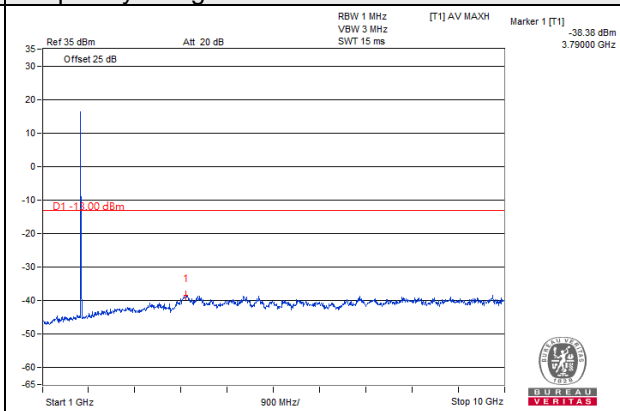

Frequency Range : 10GHz~20GHz

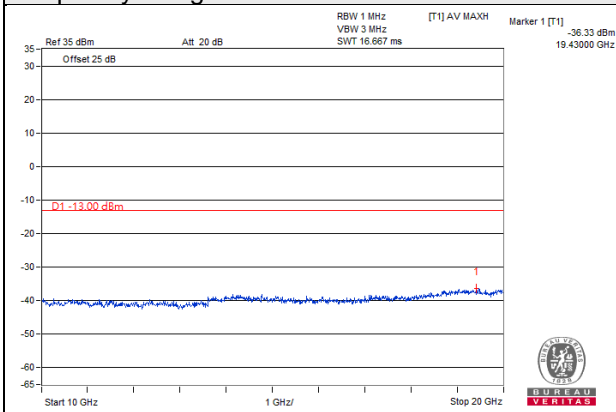

Note: The signal of 9kHz is IF signal from test instrument.

LTE Band 4 Channel Bandwidth: 1.4MHz

Channel 20393

Frequency Range : 9kHz~1GHz

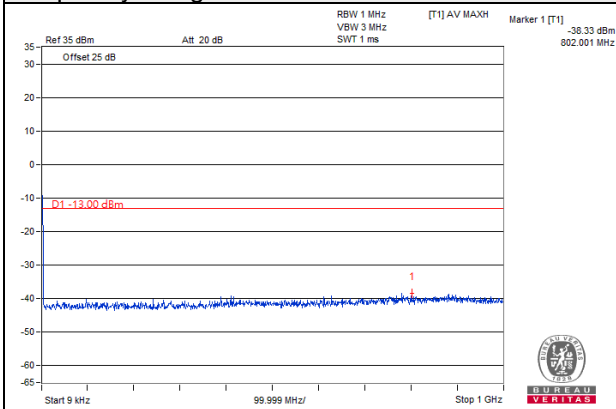

Frequency Range : 1GHz~10GHz

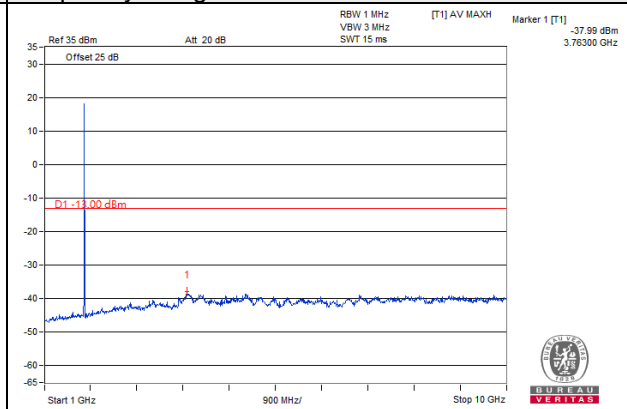

Frequency Range : 10GHz~20GHz

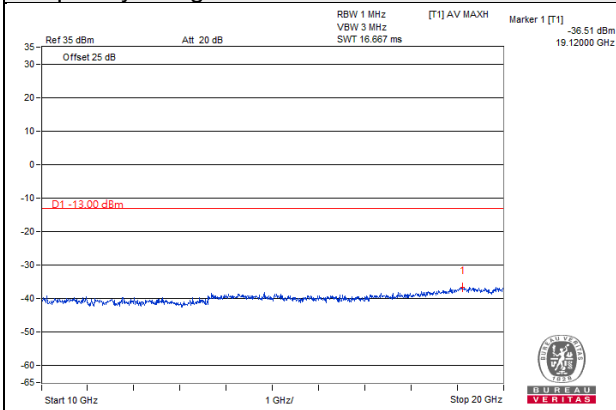

Note: The signal of 9kHz is IF signal from test instrument.

LTE Band 4 Channel Bandwidth: 3MHz

Channel 19965

Frequency Range : 9kHz~1GHz

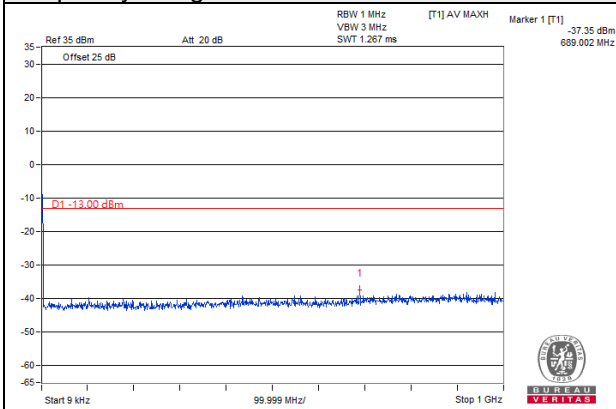

Frequency Range : 1GHz~10GHz

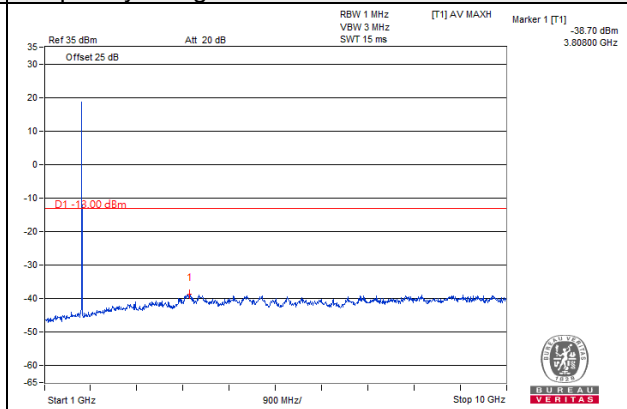

Frequency Range : 10GHz~20GHz

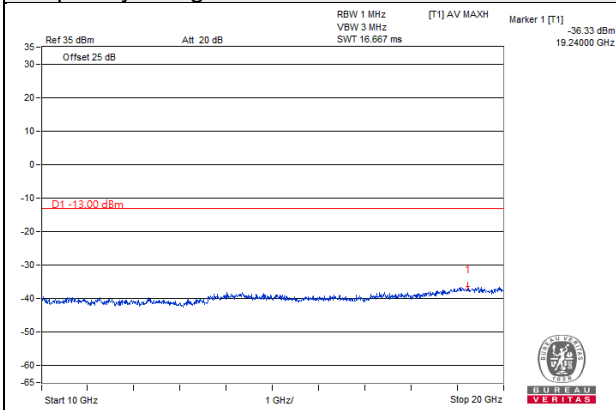

Note: The signal of 9kHz is IF signal from test instrument.

LTE Band 4 Channel Bandwidth: 3MHz

Channel 20175

Frequency Range : 9kHz~1GHz **Frequency Range : 1GHz~10GHz**

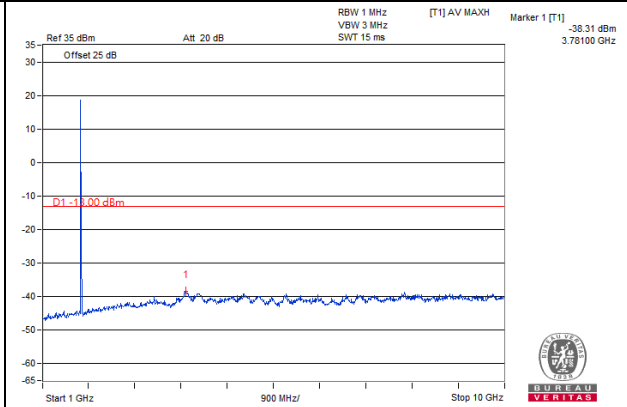
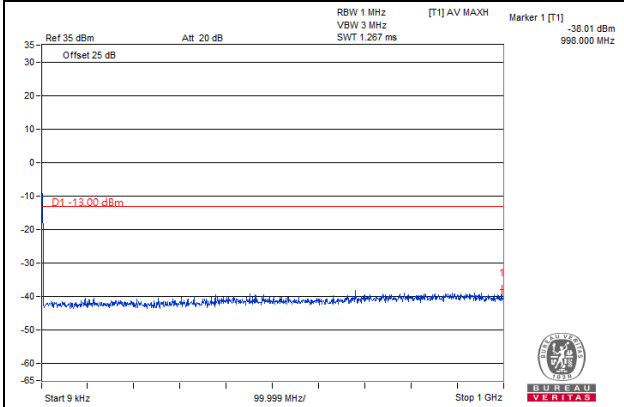

Frequency Range : 10GHz~20GHz

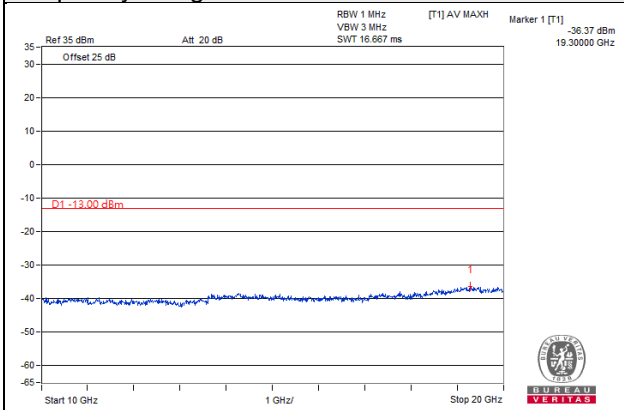

Note: The signal of 9kHz is IF signal from test instrument.

LTE Band 4 Channel Bandwidth: 3MHz

Channel 20385

Frequency Range : 9kHz~1GHz

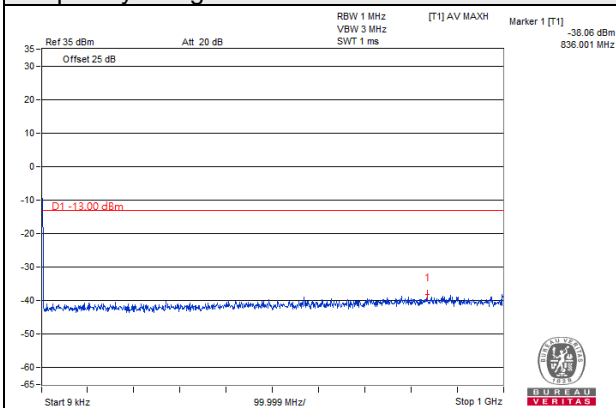

Frequency Range : 1GHz~10GHz

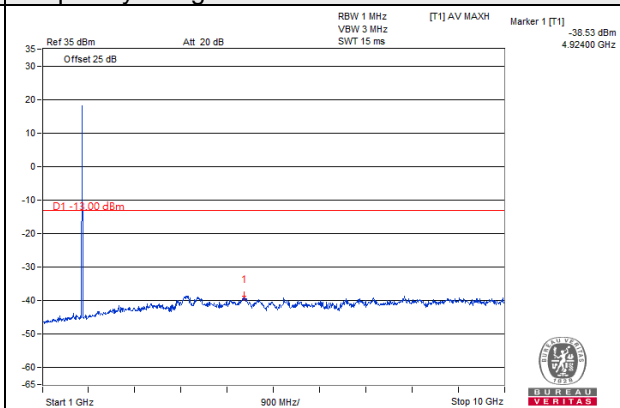

Frequency Range : 10GHz~20GHz

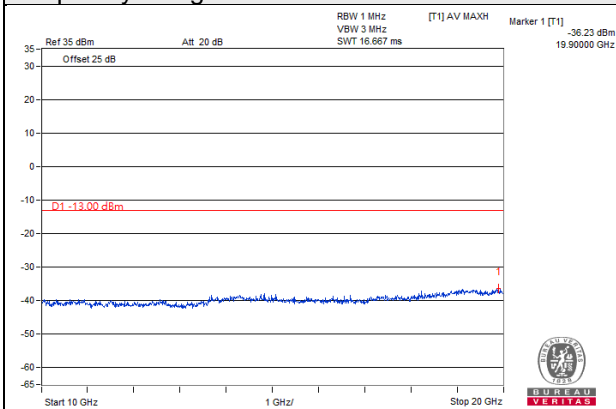

Note: The signal of 9kHz is IF signal from test instrument.

LTE Band 4 Channel Bandwidth: 5MHz

Channel 19975

Frequency Range : 9kHz~1GHz

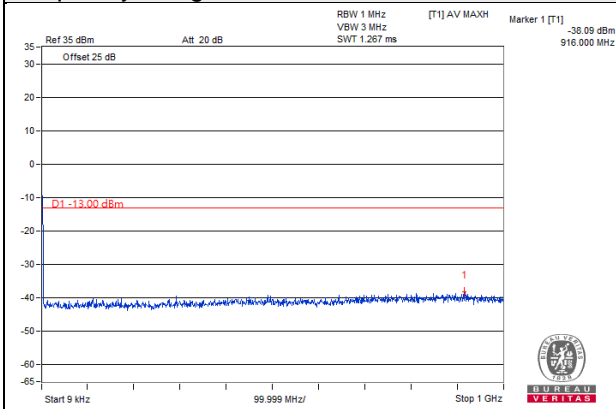

Frequency Range : 1GHz~10GHz

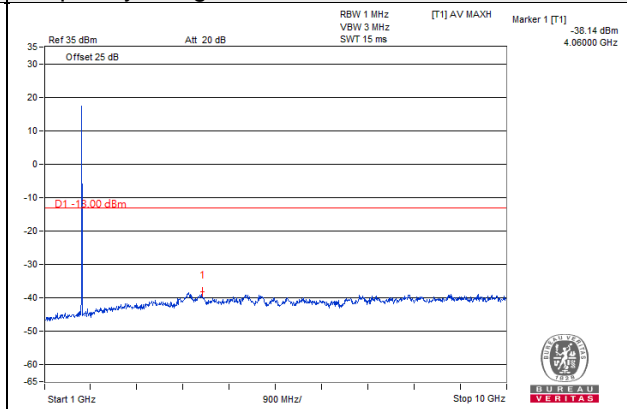

Frequency Range : 10GHz~20GHz

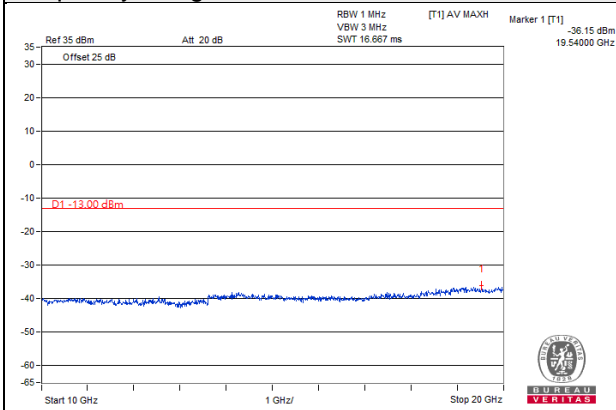

Note: The signal of 9kHz is IF signal from test instrument.

LTE Band 4 Channel Bandwidth: 5MHz

Channel 20175

Frequency Range : 9kHz~1GHz

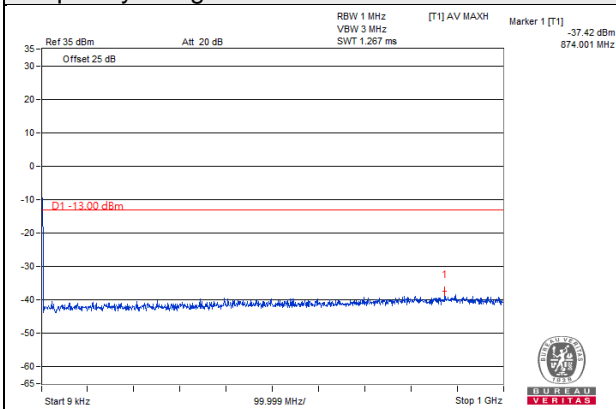

Frequency Range : 1GHz~10GHz

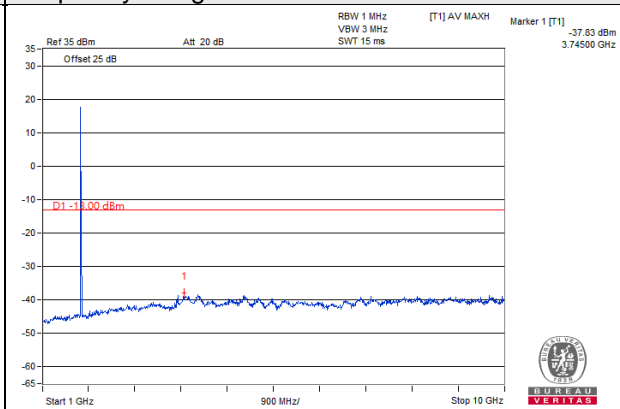

Frequency Range : 10GHz~20GHz

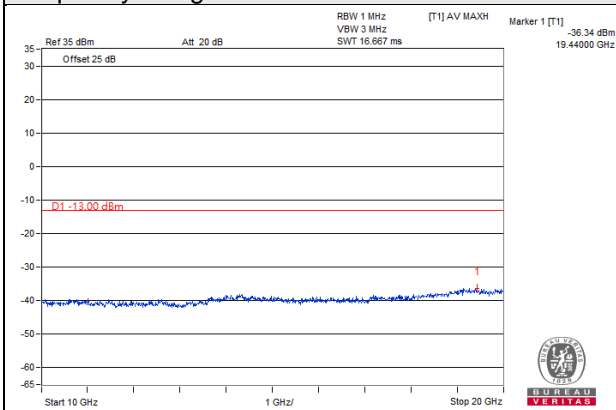

Note: The signal of 9kHz is IF signal from test instrument.

LTE Band 4 Channel Bandwidth: 5MHz

Channel 20375

Frequency Range : 9kHz~1GHz

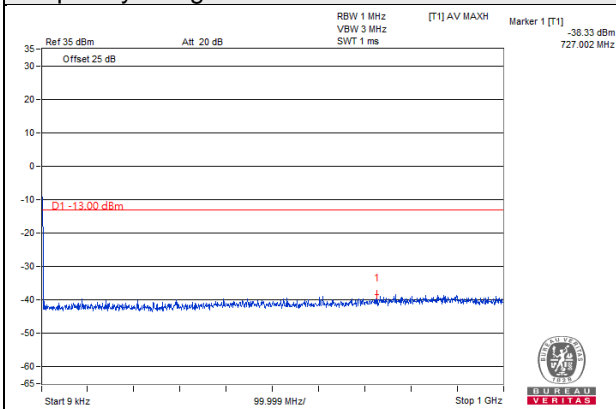

Frequency Range : 1GHz~10GHz

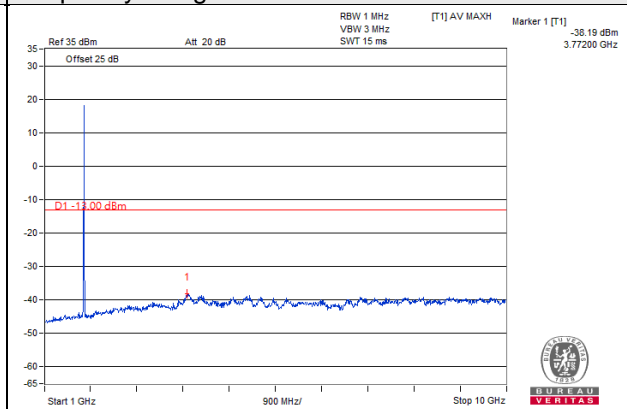

Frequency Range : 10GHz~20GHz

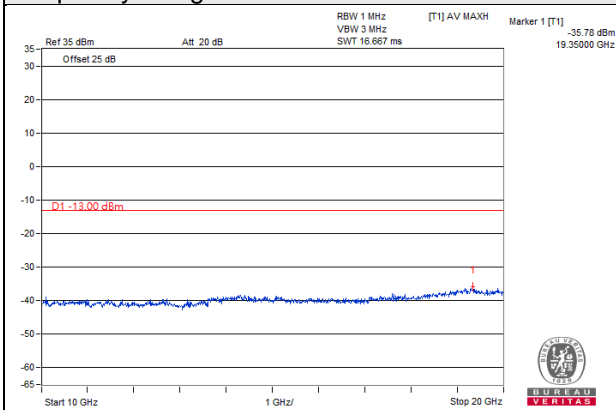

Note: The signal of 9kHz is IF signal from test instrument.

LTE Band 4 Channel Bandwidth: 10MHz

Channel 20000

Frequency Range : 9kHz~1GHz

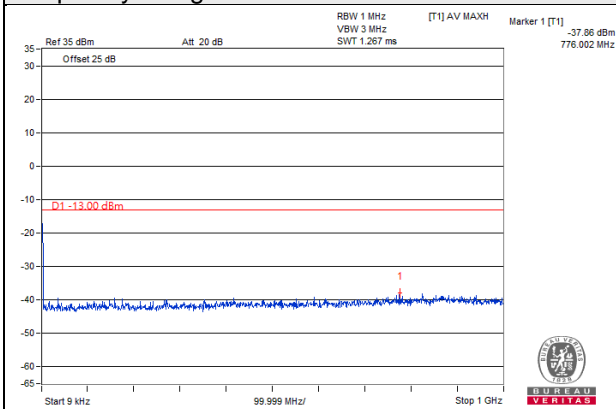

Frequency Range : 1GHz~10GHz

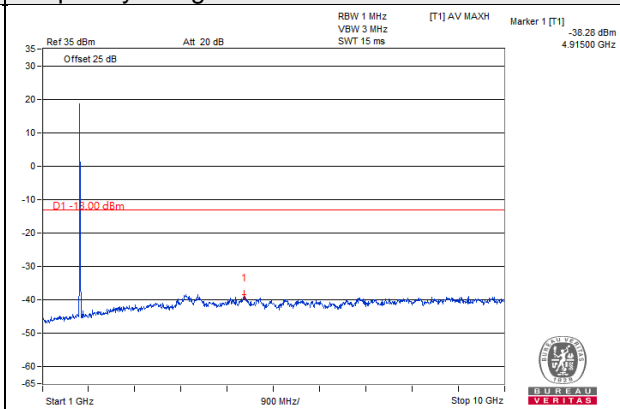

Frequency Range : 10GHz~20GHz

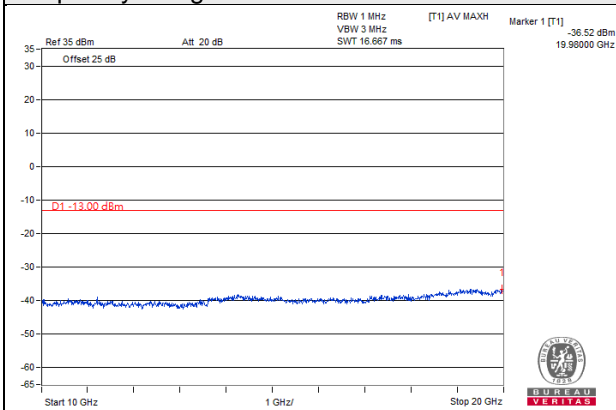

Note: The signal of 9kHz is IF signal from test instrument.

LTE Band 4 Channel Bandwidth: 10MHz

Channel 20175

Frequency Range : 9kHz~1GHz

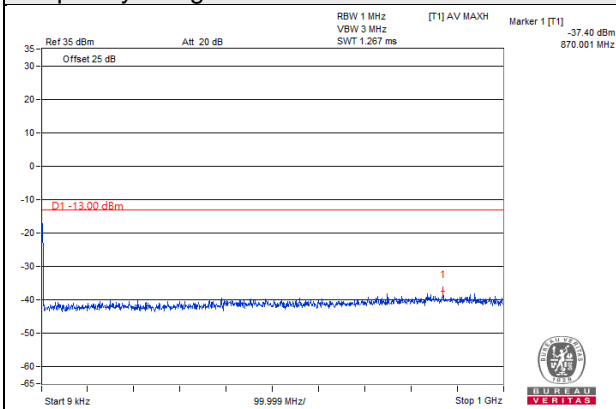

Frequency Range : 1GHz~10GHz

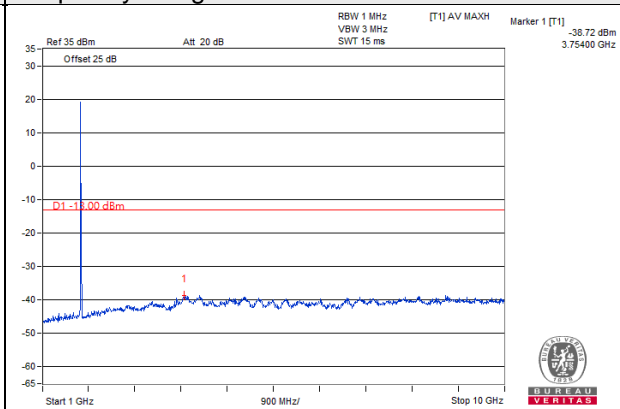

Frequency Range : 10GHz~20GHz

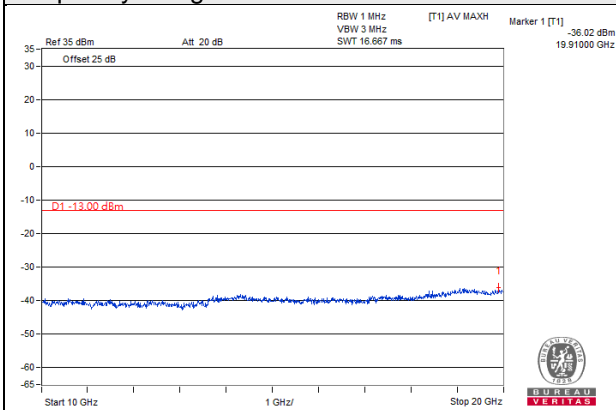

Note: The signal of 9kHz is IF signal from test instrument.

LTE Band 4 Channel Bandwidth: 10MHz
Channel 20350

Frequency Range : 9kHz~1GHz

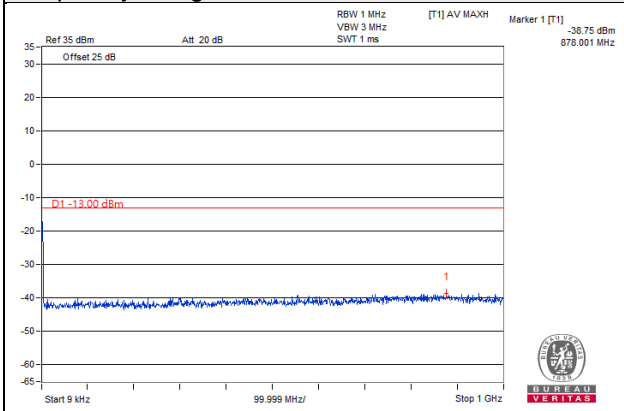

Frequency Range : 1GHz~10GHz

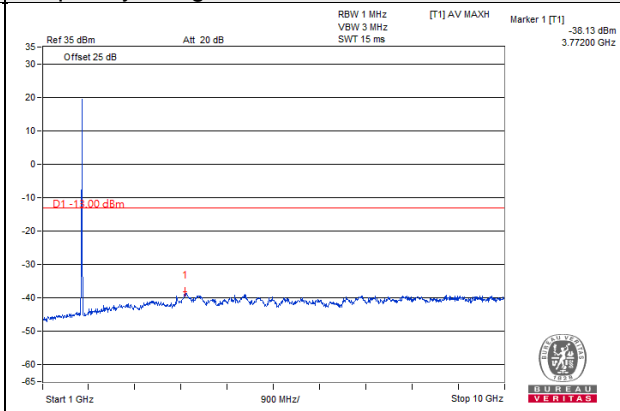

Frequency Range : 10GHz~20GHz

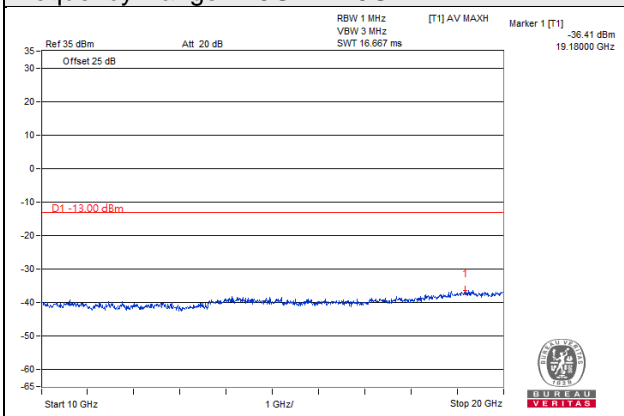

Note: The signal of 9kHz is IF signal from test instrument.

LTE Band 4 Channel Bandwidth: 15MHz

Channel 20025

Frequency Range : 9kHz~1GHz

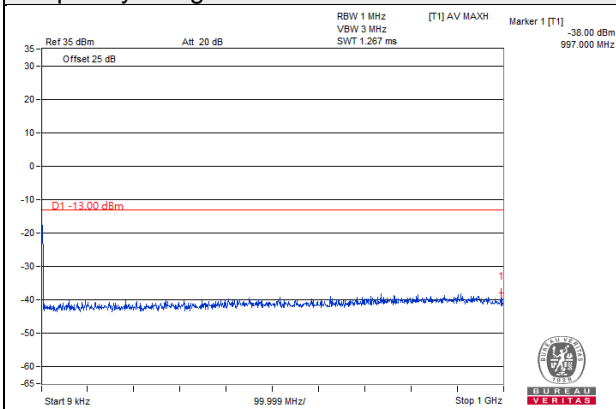

Frequency Range : 1GHz~10GHz

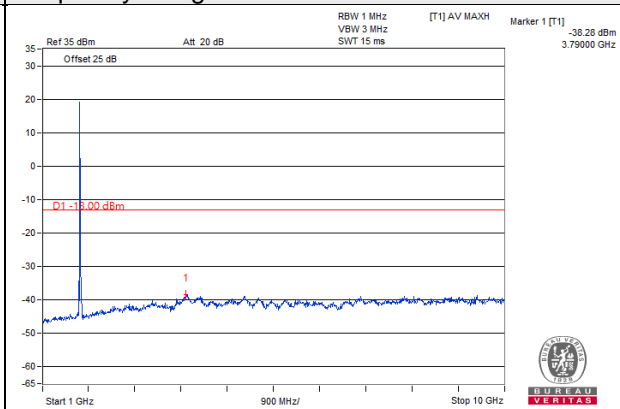

Frequency Range : 10GHz~20GHz

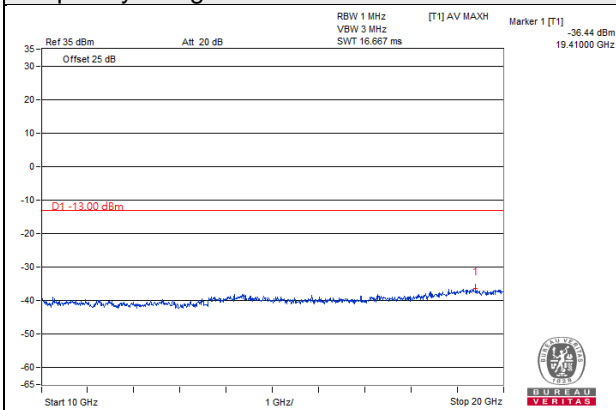

Note: The signal of 9kHz is IF signal from test instrument.

LTE Band 4 Channel Bandwidth: 15MHz

Channel 20175

Frequency Range : 9kHz~1GHz

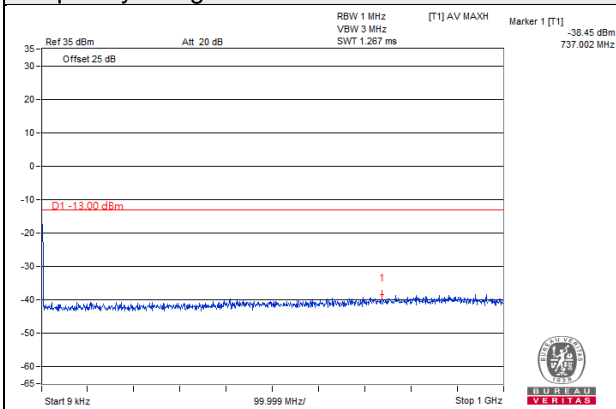

Frequency Range : 1GHz~10GHz

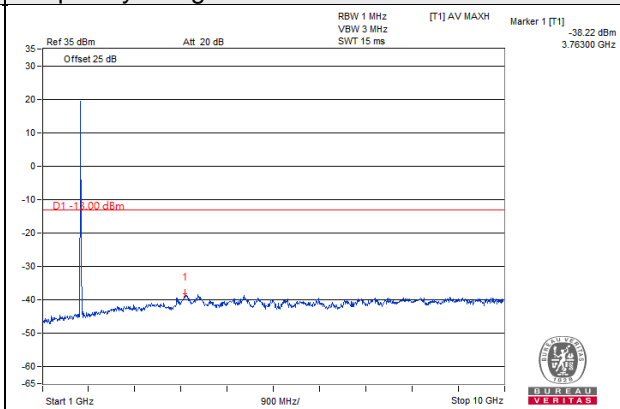

Frequency Range : 10GHz~20GHz

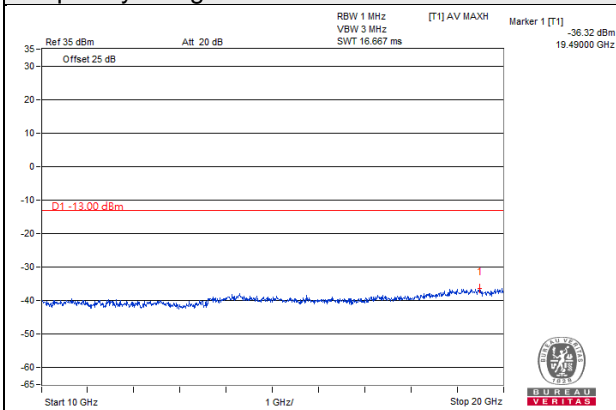

Note: The signal of 9kHz is IF signal from test instrument.

LTE Band 4 Channel Bandwidth: 15MHz

Channel 20325

Frequency Range : 9kHz~1GHz

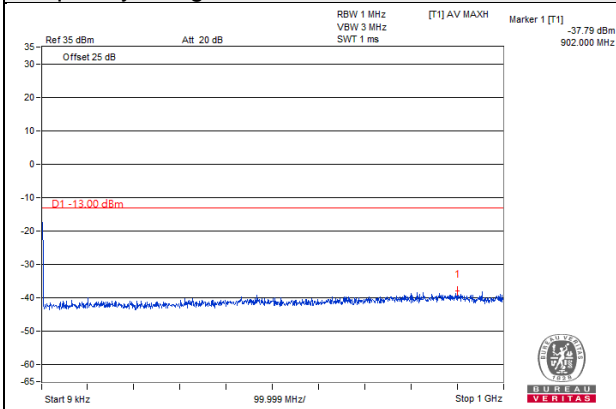

Frequency Range : 1GHz~10GHz

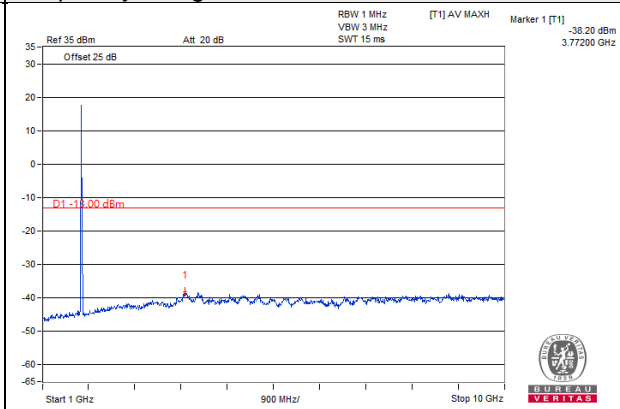

Frequency Range : 10GHz~20GHz

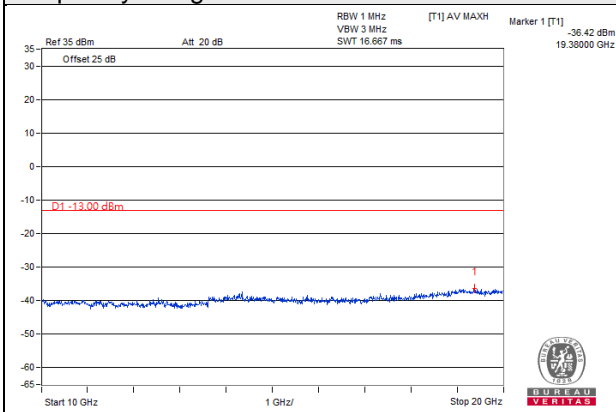

Note: The signal of 9kHz is IF signal from test instrument.

LTE Band 4 Channel Bandwidth: 20MHz

Channel 20050

Frequency Range : 9kHz~1GHz

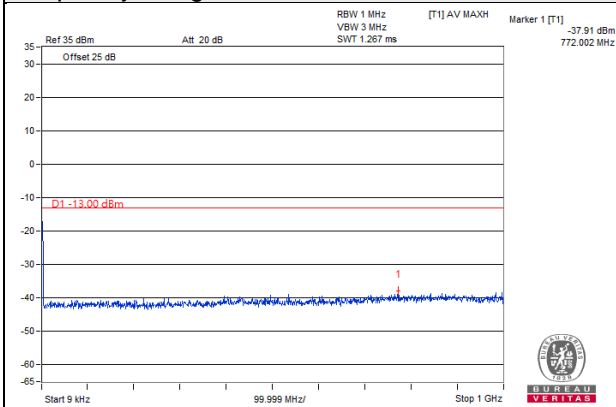

Frequency Range : 1GHz~10GHz

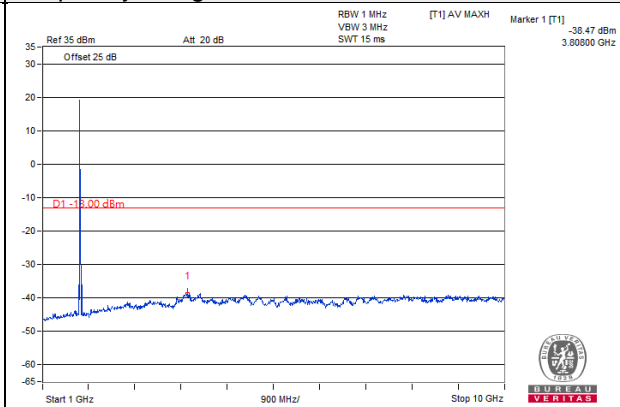

Frequency Range : 10GHz~20GHz

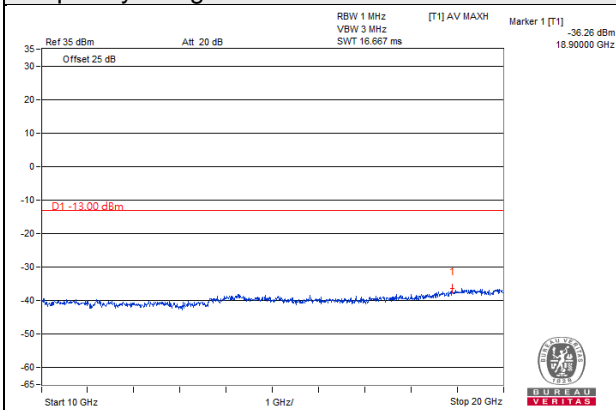

Note: The signal of 9kHz is IF signal from test instrument.

LTE Band 4 Channel Bandwidth: 20MHz

Channel 20175

Frequency Range : 9kHz~1GHz

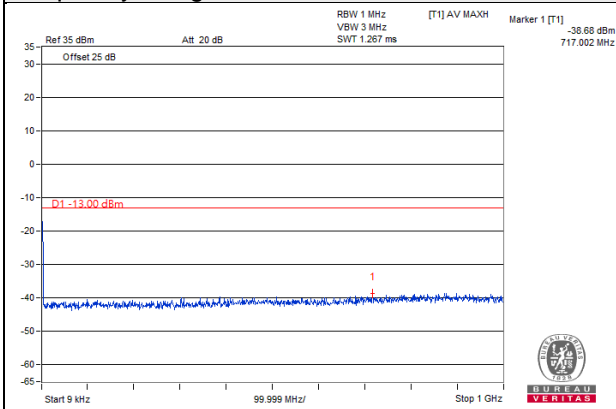

Frequency Range : 1GHz~10GHz

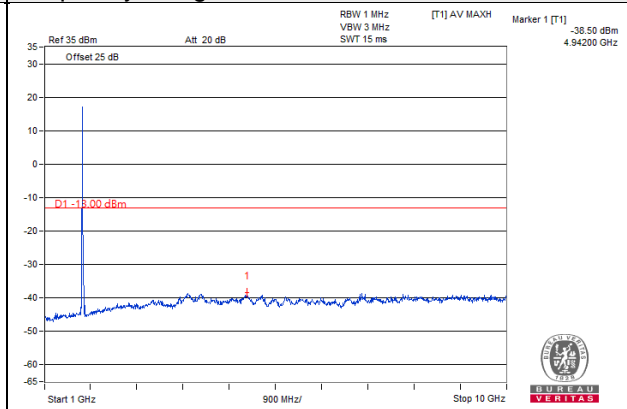

Frequency Range : 10GHz~20GHz

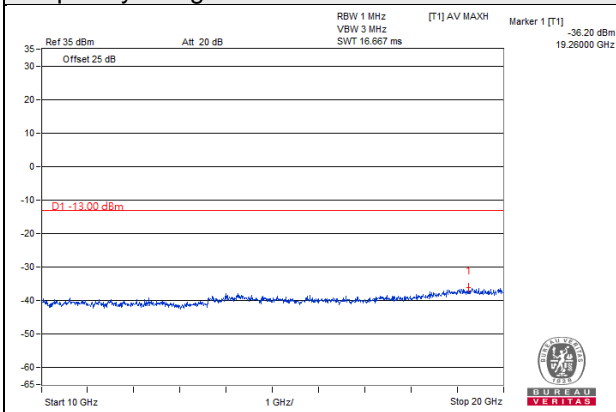

Note: The signal of 9kHz is IF signal from test instrument.

LTE Band 4 Channel Bandwidth: 20MHz

Channel 20300

Frequency Range : 9kHz~1GHz

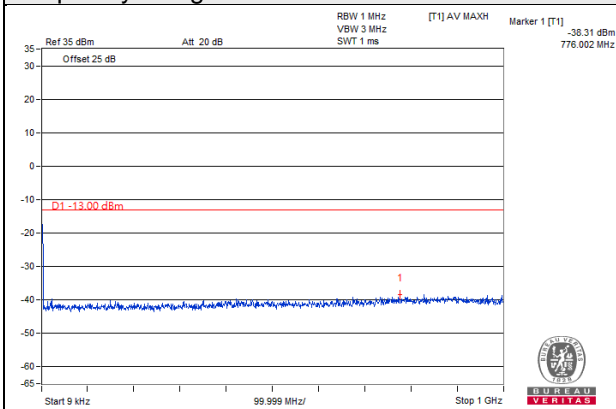

Frequency Range : 1GHz~10GHz

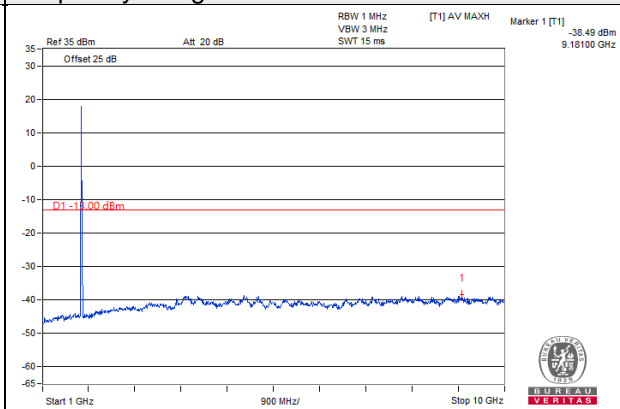

Frequency Range : 10GHz~20GHz

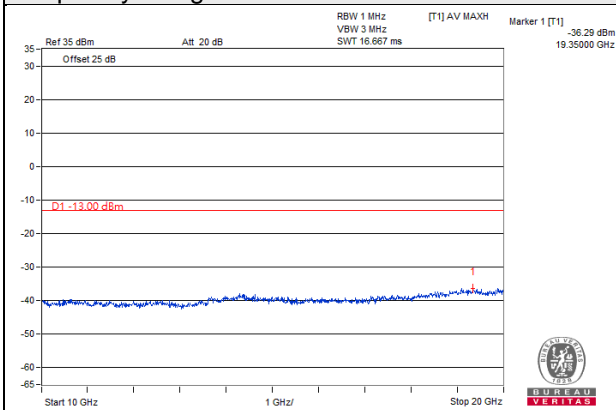

Note: The signal of 9kHz is IF signal from test instrument.

LTE Band 12 Channel Bandwidth: 1.4MHz

Channel 23017

Frequency Range : 9kHz~1GHz

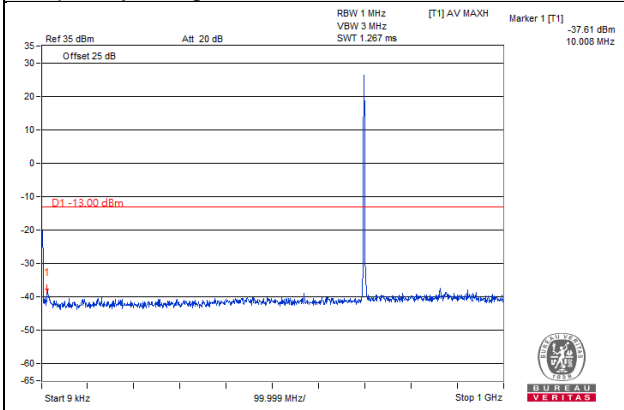

Frequency Range : 1GHz~10GHz

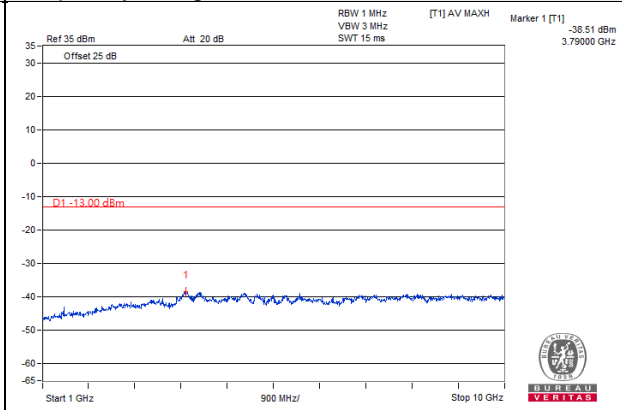

Channel 23095

Frequency Range : 9kHz~1GHz

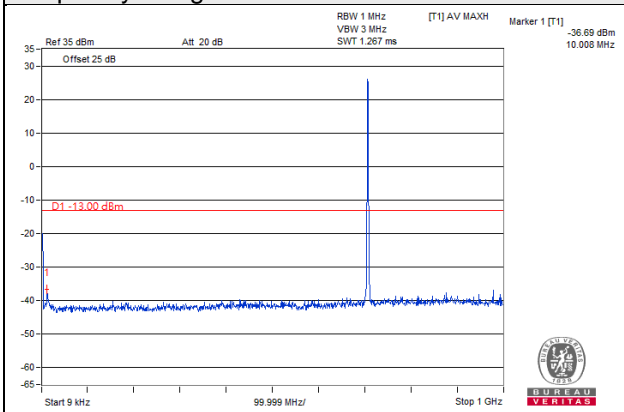

Frequency Range : 1GHz~10GHz

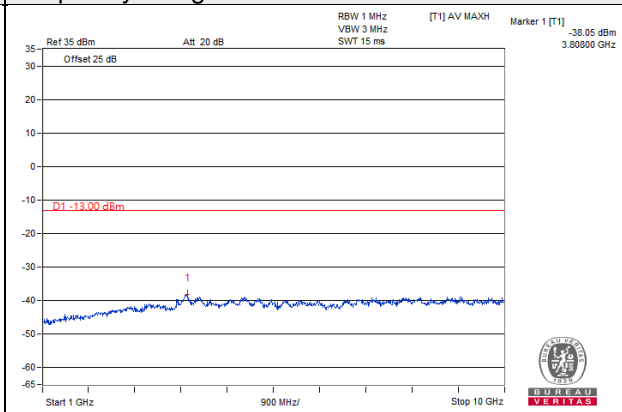

Channel 23173

Frequency Range : 9kHz~1GHz

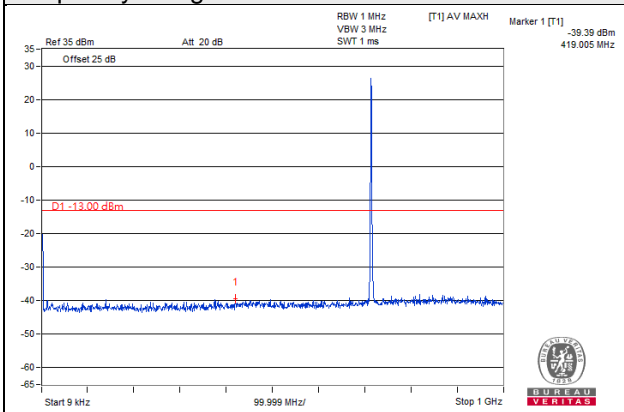

Frequency Range : 1GHz~10GHz

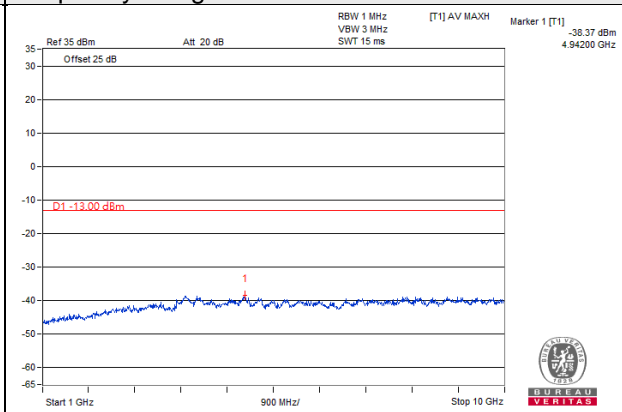

Note: The signal of 9kHz is IF signal from test instrument.

LTE Band 12 Channel Bandwidth: 3MHz

Channel 23025

Frequency Range : 9kHz~1GHz

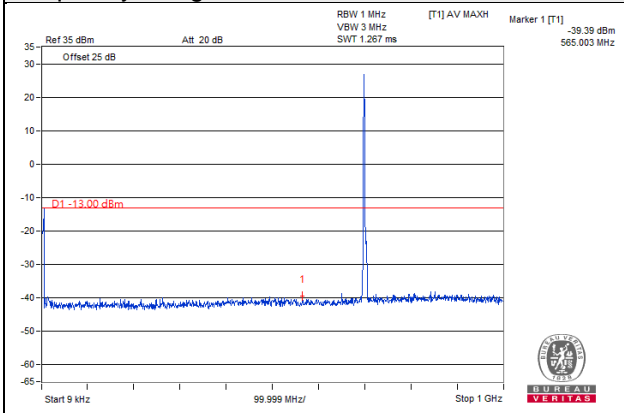

Frequency Range : 1GHz~10GHz

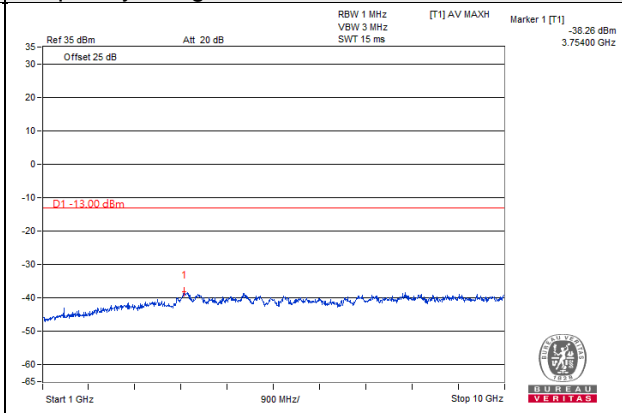

Channel 23095

Frequency Range : 9kHz~1GHz

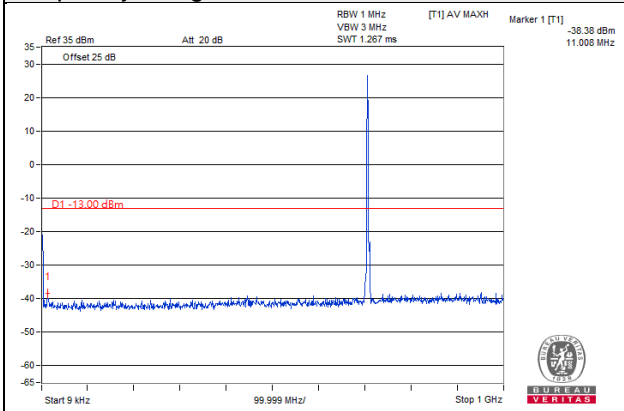

Frequency Range : 1GHz~10GHz

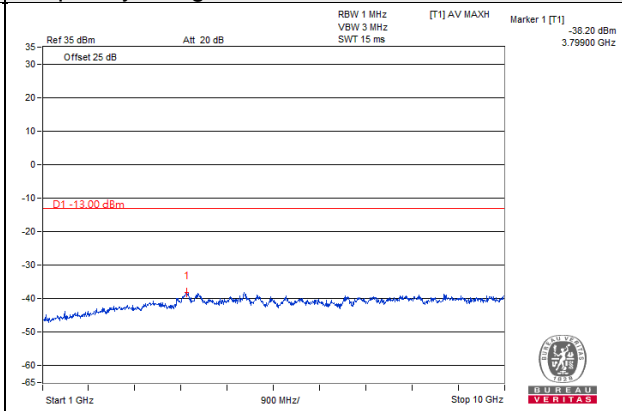

Channel 23165

Frequency Range : 9kHz~1GHz

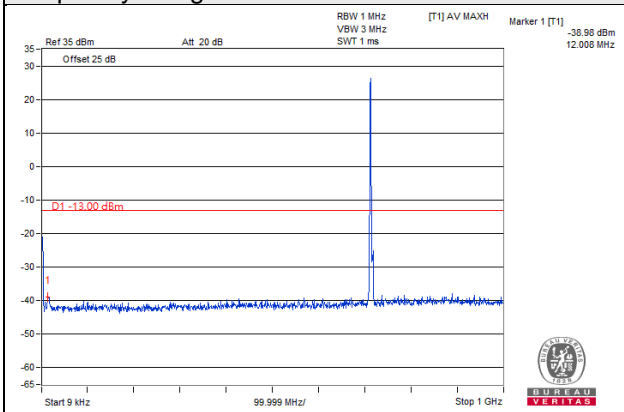

Frequency Range : 1GHz~10GHz

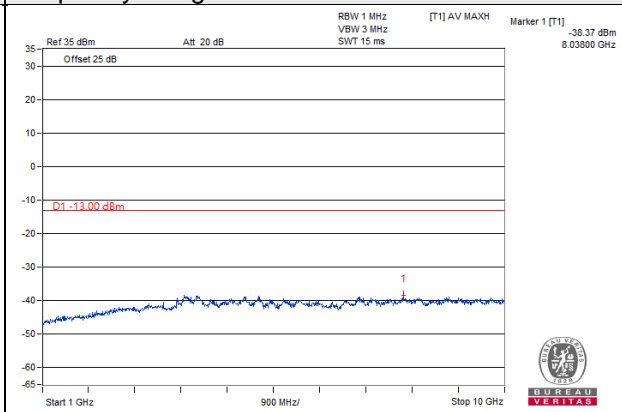

Note: The signal of 9kHz is IF signal from test instrument.

LTE Band 12 Channel Bandwidth: 5MHz

Channel 23035

Frequency Range : 9kHz~1GHz

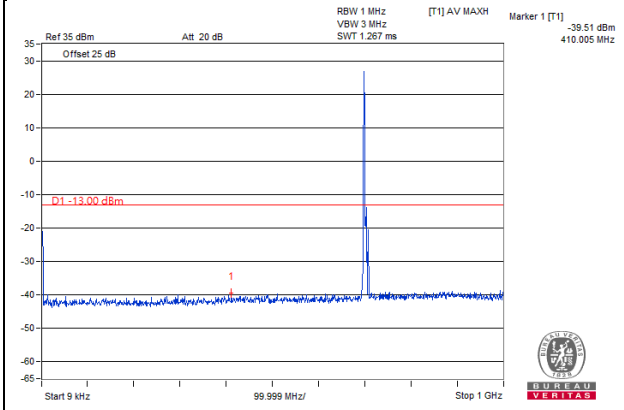

Frequency Range : 1GHz~10GHz

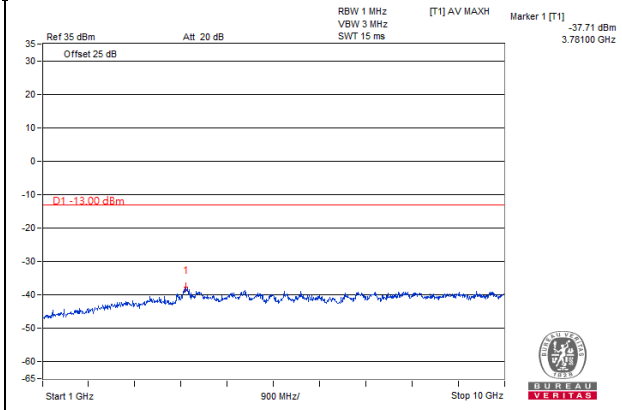

Channel 23095

Frequency Range : 9kHz~1GHz

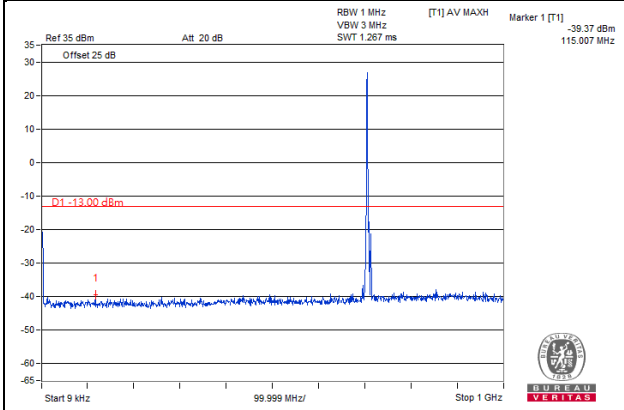

Frequency Range : 1GHz~10GHz

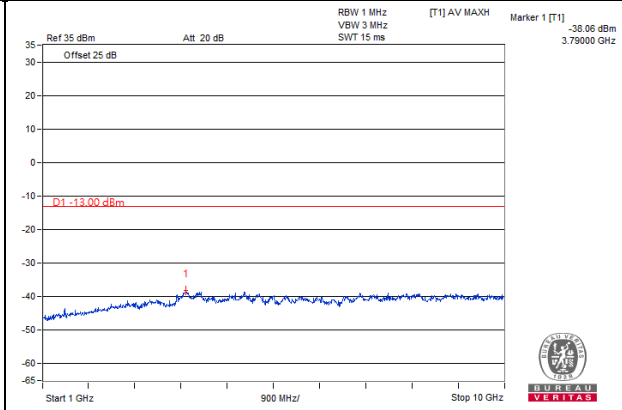

Channel 23155

Frequency Range : 9kHz~1GHz

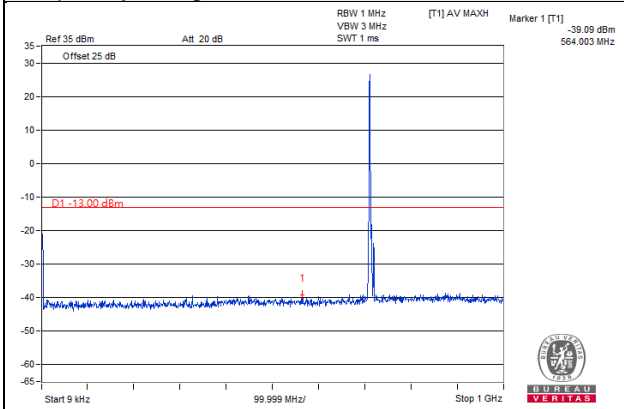

Frequency Range : 1GHz~10GHz

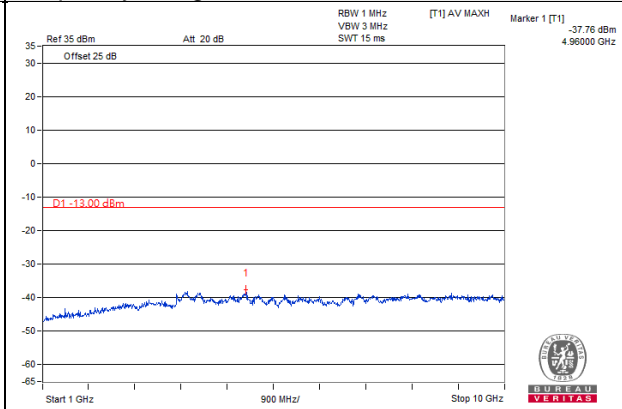

Note: The signal of 9kHz is IF signal from test instrument.

LTE Band 12 Channel Bandwidth: 10MHz

Channel 23060

Frequency Range : 9kHz~1GHz

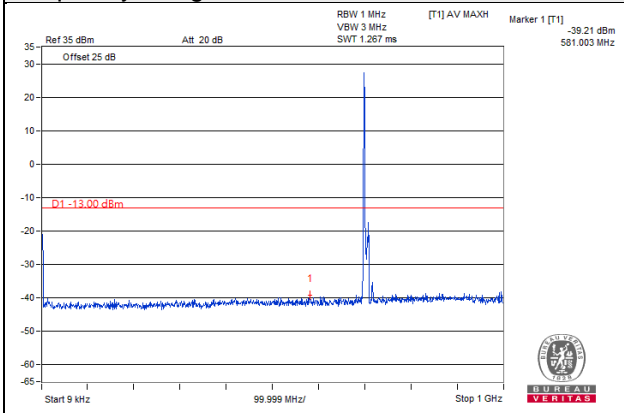

Frequency Range : 1GHz~10GHz

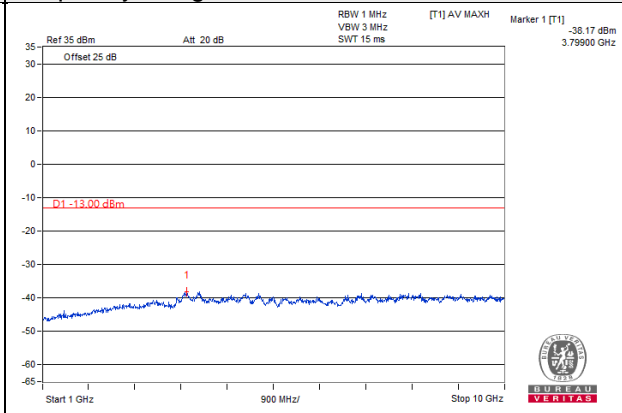

Channel 23095

Frequency Range : 9kHz~1GHz

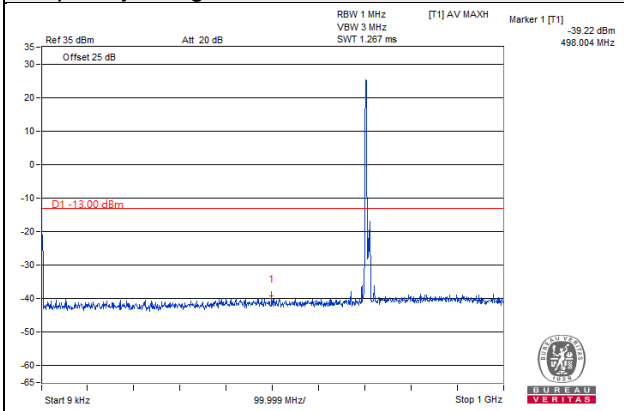

Frequency Range : 1GHz~10GHz

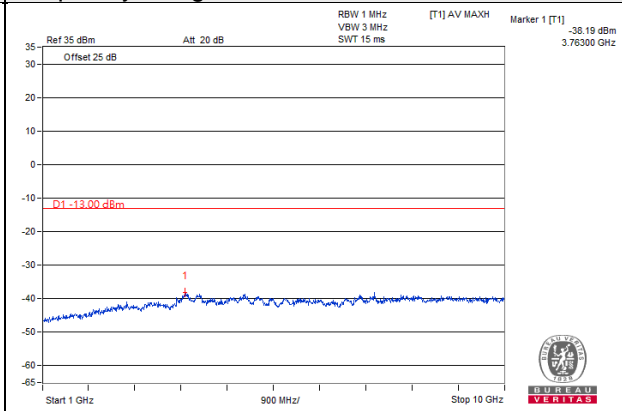

Channel 23130

Frequency Range : 9kHz~1GHz

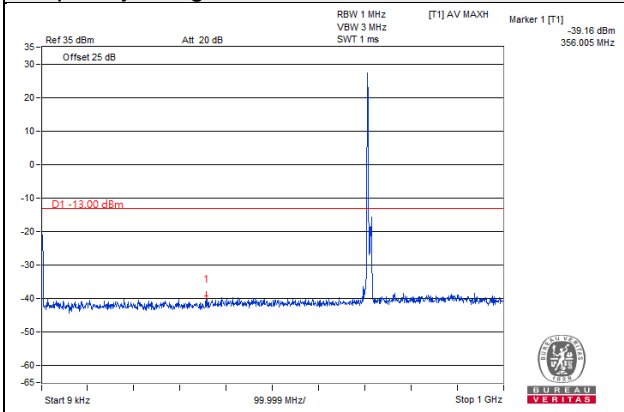

Frequency Range : 1GHz~10GHz

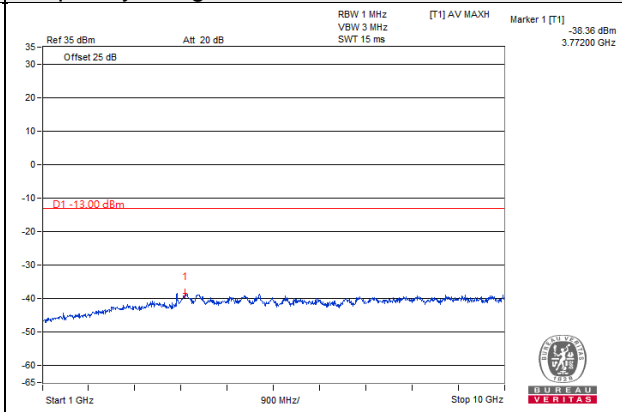

Note: The signal of 9kHz is IF signal from test instrument.

LTE Band 13 Channel Bandwidth: 5MHz

Channel 23205

Frequency Range : 9kHz~1GHz

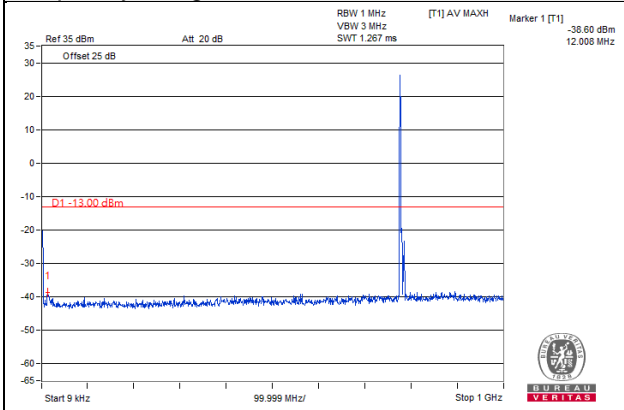

Frequency Range : 1GHz~10GHz

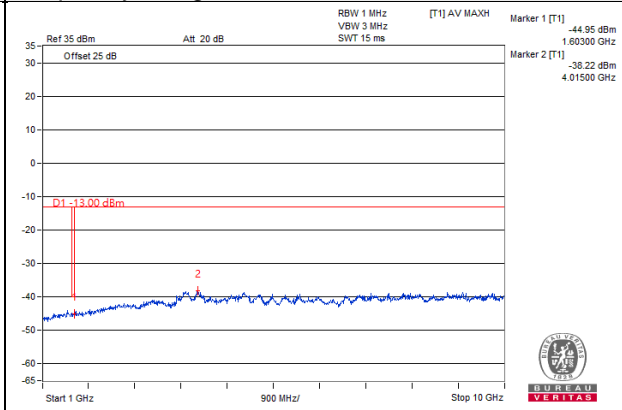

Channel 23230

Frequency Range : 9kHz~1GHz

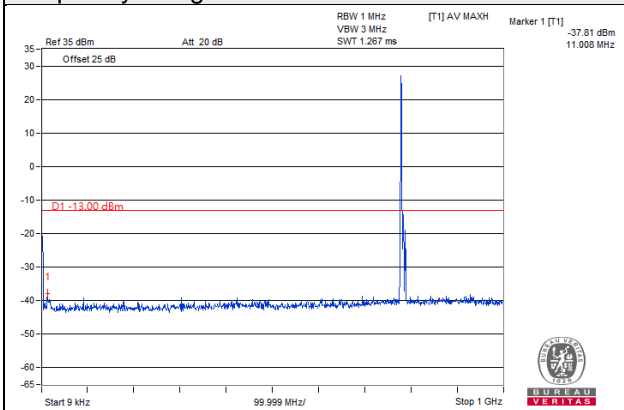

Frequency Range : 1GHz~10GHz

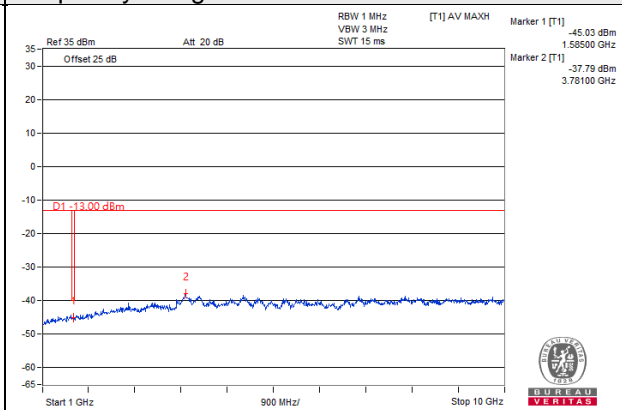

Channel 23255

Frequency Range : 9kHz~1GHz

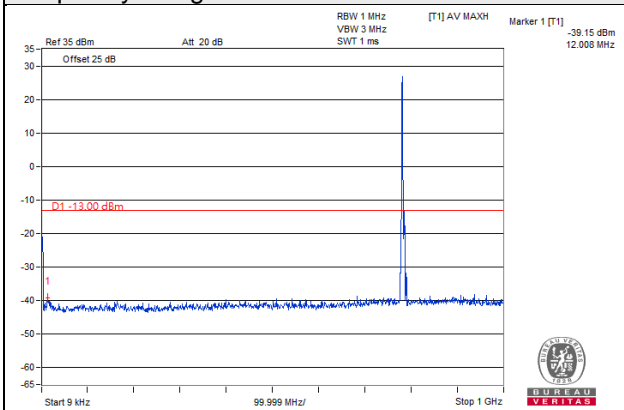

Frequency Range : 1GHz~10GHz

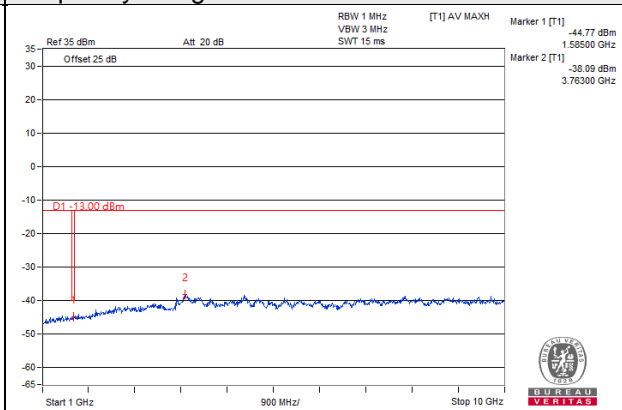

Note: The signal of 9kHz is IF signal from test instrument.

LTE Band 13 Channel Bandwidth: 10MHz

Channel 23230

Frequency Range : 9kHz~1GHz

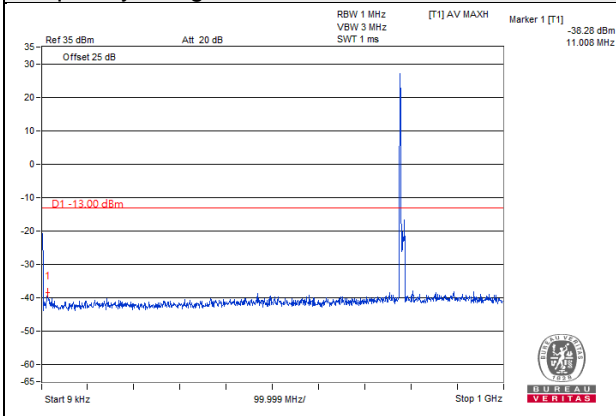

Frequency Range : 1GHz~10GHz

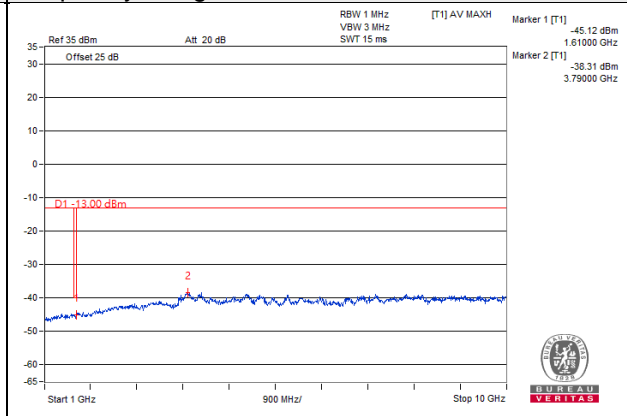

Note: The signal of 9kHz is IF signal from test instrument.

4.8 Radiated Emission Measurement

4.8.1 Limits of Radiated Emission Measurement

According to FCC 27.53(g) For operations in the 600 MHz band and the 698-746 MHz band, the power of any emission outside a licensee's frequency band(s) of operation shall be attenuated below the transmitter power (P) within the licensed band(s) of operation, measured in watts, by at least $43 + 10 \log (P)$ dB. Compliance with this provision is based on the use of measurement instrumentation employing a resolution bandwidth of 100 kilohertz or greater. However, in the 100 kilohertz bands immediately outside and adjacent to a licensee's frequency block, a resolution bandwidth of at least 30 kHz may be employed.

According to FCC 27.53(h) AWS emission limits— General protection levels. Except as otherwise specified below, for operations in the 1695-1710 MHz, 1710-1755 MHz, 1755-1780 MHz, 1915-1920 MHz, 1995-2000 MHz, 2000-2020 MHz, 2110-2155 MHz, 2155-2180 MHz, and 2180-2200 bands, the power of any emission outside a licensee's frequency block shall be attenuated below the transmitter power (P) in watts by at least $43 + 10 \log_{10} (P)$ dB.

According to FCC 27.53 (c) For operations in the 746-758 MHz band and the 776-788 MHz band, the power of any emission outside the licensee's frequency band(s) of operation shall be attenuated below the transmitter power (P) within the licensed band(s) of operation, measured in watts, in accordance with the following:

- (1) On any frequency outside the 746-758 MHz band, the power of any emission shall be attenuated outside the band below the transmitter power (P) by at least $43 + 10 \log (P)$ dB;
- (2) On any frequency outside the 776-788 MHz band, the power of any emission shall be attenuated outside the band below the transmitter power (P) by at least $43 + 10 \log (P)$ dB;
- (3) On all frequencies between 763-775 MHz and 793-805 MHz, by a factor not less than $76 + 10 \log (P)$ dB in a 6.25 kHz band segment, for base and fixed stations;
- (4) On all frequencies between 763-775 MHz and 793-805 MHz, by a factor not less than $65 + 10 \log (P)$ dB in a 6.25 kHz band segment, for mobile and portable stations;
- (5) Compliance with the provisions of paragraphs (c)(1) and (c)(2) of this section is based on the use of measurement instrumentation employing a resolution bandwidth of 100 kHz or greater. However, in the 100 kHz bands immediately outside and adjacent to the frequency block, a resolution bandwidth of at least 30 kHz may be employed;
- (6) Compliance with the provisions of paragraphs (c)(3) and (c)(4) of this section is based on the use of measurement instrumentation such that the reading taken with any resolution bandwidth setting should be adjusted to indicate spectral energy in a 6.25 kHz segment.

According to FCC 27.53(f) For operations in the 746–758 MHz, 775–788 MHz, and 805–806 MHz bands, emissions in the band 1559–1610 MHz shall be limited to -70 dBW/MHz equivalent isotropically radiated power (EIRP) for wideband signals, and -80 dBW EIRP for discrete emissions of less than 700 Hz bandwidth.

4.8.2 Test Procedure

- a. The power was measured with Spectrum Analyzer. All measurements were done at 3 channels (low, middle and high channel of operational frequency range.)
- b. Substitution method is used for EIRP measurement. In the semi-anechoic chamber, EUT placed on the 0.8m/1.5m height of Turn Table, rotated the table around 360 degrees to search the maximum radiation power and receiver antenna shall be rotated vertical and horizontal polarization and moved height from 1m to 4m to find the maximum polar radiated power. The "Read Value" is the spectrum reading the maximum power value.
- c. Follow ANSI 63.26 section 5.2.7 d), EIRP Value (dBm) = Read Value (dB μ V/m) - Correction Factor @ 3m
- d. Correction Factor (dB) @ 3m = $20\log(D) - 104.8$; where D is the measurement distance @ 3m = -95.26dB

NOTE: The resolution bandwidth and video bandwidth of test receiver/spectrum analyzer is 1MHz/3MHz.

4.8.3 Deviation from Test Standard

No deviation.

4.8.4 Test Setup

<Frequency Range below 1GHz>

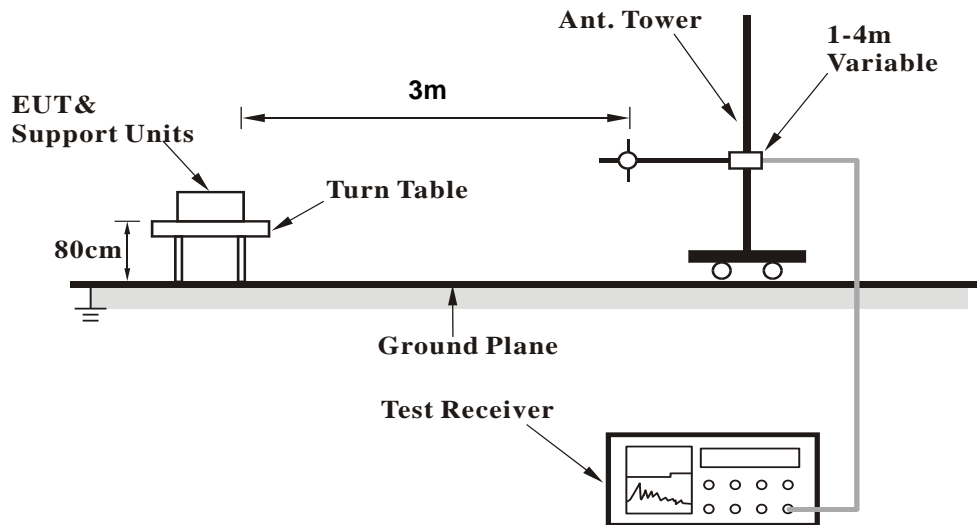

<Frequency Range above 1GHz>

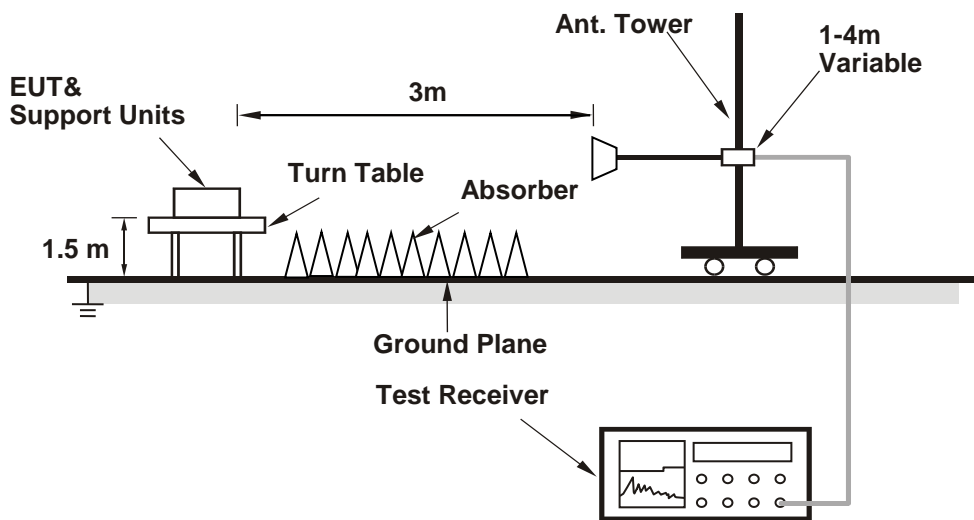

For the actual test configuration, please refer to the attached file (Test Setup Photo).

4.8.5 Test Results

Below 1GHz

LTE Band 4: 1.4MHz

Mode	TX channel 19957	Frequency Range	Below 1000 MHz
------	------------------	-----------------	----------------

Antenna Polarity & Test Distance: Horizontal at 3 M						
No.	Freq. (MHz)	Reading (dB μ V/m)	Correction Factor (dB)	EIRP (dBm)	Limit (dBm)	Margin (dB)
1	189.9	33.26	-95.26	-62.00	-13	-49.00
2	235.64	35.65	-95.26	-59.61	-13	-46.61
3	271.08	28.9	-95.26	-66.36	-13	-53.36
4	293.49	31.74	-95.26	-63.52	-13	-50.52
5	757.87	32.9	-95.26	-62.36	-13	-49.36
6	902.56	27.57	-95.26	-67.69	-13	-54.69
Antenna Polarity & Test Distance: Vertical at 3 M						
No.	Freq. (MHz)	Reading (dB μ V/m)	Correction Factor (dB)	EIRP (dBm)	Limit (dBm)	Margin (dB)
1	54.12	35.41	-95.26	-59.85	-13	-46.85
2	74.35	35.46	-95.26	-59.80	-13	-46.80
3	144.73	30.13	-95.26	-65.13	-13	-52.13
4	179.7	27.58	-95.26	-67.68	-13	-54.68
5	212.34	36.03	-95.26	-59.23	-13	-46.23
6	837.83	35.15	-95.26	-60.11	-13	-47.11

Remarks:

1. Follow ANSI 63.26 section 5.2.7 d), EIRP Value (dBm) = E (dB μ V/m) - Correction Factor @ 3m.
2. Correction Factor (dB) = 20log(D) - 104.8; where D is the measurement distance @ 3m.

Mode	TX channel 20175	Frequency Range	Below 1000 MHz
------	------------------	-----------------	----------------

Antenna Polarity & Test Distance: Horizontal at 3 M

No.	Freq. (MHz)	Reading (dB μ V/m)	Correction Factor (dB)	EIRP (dBm)	Limit (dBm)	Margin (dB)
1	198	33.69	-95.26	-61.57	-13	-48.57
2	237.36	36.6	-95.26	-58.66	-13	-45.66
3	274.67	31.07	-95.26	-64.19	-13	-51.19
4	296.89	35.29	-95.26	-59.97	-13	-46.97
5	761.85	30.69	-95.26	-64.57	-13	-51.57
6	904	31.4	-95.26	-63.86	-13	-50.86

Antenna Polarity & Test Distance: Vertical at 3 M

No.	Freq. (MHz)	Reading (dB μ V/m)	Correction Factor (dB)	EIRP (dBm)	Limit (dBm)	Margin (dB)
1	56.41	36.58	-95.26	-58.68	-13	-45.68
2	73.93	39.67	-95.26	-55.59	-13	-42.59
3	146.3	31.24	-95.26	-64.02	-13	-51.02
4	184.22	29.23	-95.26	-66.03	-13	-53.03
5	214.28	33.46	-95.26	-61.80	-13	-48.80
6	838.21	35.25	-95.26	-60.01	-13	-47.01

Remarks:

1. Follow ANSI 63.26 section 5.2.7 d), EIRP Value (dBm) = E (dB μ V/m) - Correction Factor @ 3m.
2. Correction Factor (dB) = 20log(D) - 104.8; where D is the measurement distance @ 3m.

Mode	TX channel 20393	Frequency Range	Below 1000 MHz
------	------------------	-----------------	----------------

Antenna Polarity & Test Distance: Horizontal at 3 M

No.	Freq. (MHz)	Reading (dB μ V/m)	Correction Factor (dB)	EIRP (dBm)	Limit (dBm)	Margin (dB)
1	201.43	34.91	-95.26	-60.35	-13	-47.35
2	242.42	38.12	-95.26	-57.14	-13	-44.14
3	281.24	28.69	-95.26	-66.57	-13	-53.57
4	300.06	31.93	-95.26	-63.33	-13	-50.33
5	764.46	33.93	-95.26	-61.33	-13	-48.33
6	904.81	32.68	-95.26	-62.58	-13	-49.58

Antenna Polarity & Test Distance: Vertical at 3 M

No.	Freq. (MHz)	Reading (dB μ V/m)	Correction Factor (dB)	EIRP (dBm)	Limit (dBm)	Margin (dB)
1	58.88	35.96	-95.26	-59.30	-13	-46.30
2	82	35.2	-95.26	-60.06	-13	-47.06
3	150.18	32.37	-95.26	-62.89	-13	-49.89
4	186.79	27.62	-95.26	-67.64	-13	-54.64
5	220.51	33.69	-95.26	-61.57	-13	-48.57
6	844.75	30.15	-95.26	-65.11	-13	-52.11

Remarks:

1. Follow ANSI 63.26 section 5.2.7 d), EIRP Value (dBm) = E (dB μ V/m) - Correction Factor @ 3m.
2. Correction Factor (dB) = $20\log(D) - 104.8$; where D is the measurement distance @ 3m.

LTE Band 4: 3MHz

Mode	TX channel 19965	Frequency Range	Below 1000 MHz
------	------------------	-----------------	----------------

Antenna Polarity & Test Distance: Horizontal at 3 M

No.	Freq. (MHz)	Reading (dB μ V/m)	Correction Factor (dB)	EIRP (dBm)	Limit (dBm)	Margin (dB)
1	208.61	32.61	-95.26	-62.65	-13	-49.65
2	243.1	36.66	-95.26	-58.60	-13	-45.60
3	287.49	28.31	-95.26	-66.95	-13	-53.95
4	304.58	33.38	-95.26	-61.88	-13	-48.88
5	764.32	33.15	-95.26	-62.11	-13	-49.11
6	908.02	32.45	-95.26	-62.81	-13	-49.81

Antenna Polarity & Test Distance: Vertical at 3 M

No.	Freq. (MHz)	Reading (dB μ V/m)	Correction Factor (dB)	EIRP (dBm)	Limit (dBm)	Margin (dB)
1	58.76	35.39	-95.26	-59.87	-13	-46.87
2	82.98	35.7	-95.26	-59.56	-13	-46.56
3	150.54	34.84	-95.26	-60.42	-13	-47.42
4	189.44	28.13	-95.26	-67.13	-13	-54.13
5	226.87	36.51	-95.26	-58.75	-13	-45.75
6	848.94	31.55	-95.26	-63.71	-13	-50.71

Remarks:

1. Follow ANSI 63.26 section 5.2.7 d), EIRP Value (dBm) = E (dB μ V/m) - Correction Factor @ 3m.
2. Correction Factor (dB) = 20log(D) - 104.8; where D is the measurement distance @ 3m.

Mode	TX channel 20175	Frequency Range	Below 1000 MHz
------	------------------	-----------------	----------------

Antenna Polarity & Test Distance: Horizontal at 3 M

No.	Freq. (MHz)	Reading (dB μ V/m)	Correction Factor (dB)	EIRP (dBm)	Limit (dBm)	Margin (dB)
1	211.32	33.83	-95.26	-61.43	-13	-48.43
2	243.27	34.71	-95.26	-60.55	-13	-47.55
3	295	26.94	-95.26	-68.32	-13	-55.32
4	306.65	35.34	-95.26	-59.92	-13	-46.92
5	767.8	31.36	-95.26	-63.90	-13	-50.90
6	909.58	33.66	-95.26	-61.60	-13	-48.60

Antenna Polarity & Test Distance: Vertical at 3 M

No.	Freq. (MHz)	Reading (dB μ V/m)	Correction Factor (dB)	EIRP (dBm)	Limit (dBm)	Margin (dB)
1	66.33	34.59	-95.26	-60.67	-13	-47.67
2	89.49	34.09	-95.26	-61.17	-13	-48.17
3	156.75	31.36	-95.26	-63.90	-13	-50.90
4	195.79	30.18	-95.26	-65.08	-13	-52.08
5	228.76	32.23	-95.26	-63.03	-13	-50.03
6	852.82	34.04	-95.26	-61.22	-13	-48.22

Remarks:

1. Follow ANSI 63.26 section 5.2.7 d), EIRP Value (dBm) = E (dB μ V/m) - Correction Factor @ 3m.
2. Correction Factor (dB) = $20\log(D) - 104.8$; where D is the measurement distance @ 3m.

Mode	TX channel 20385	Frequency Range	Below 1000 MHz
------	------------------	-----------------	----------------

Antenna Polarity & Test Distance: Horizontal at 3 M

No.	Freq. (MHz)	Reading (dB μ V/m)	Correction Factor (dB)	EIRP (dBm)	Limit (dBm)	Margin (dB)
1	216.74	37.44	-95.26	-57.82	-13	-44.82
2	249.18	34.01	-95.26	-61.25	-13	-48.25
3	300.85	26.69	-95.26	-68.57	-13	-55.57
4	307.96	37.75	-95.26	-57.51	-13	-44.51
5	769.62	31.57	-95.26	-63.69	-13	-50.69
6	911.95	28.46	-95.26	-66.80	-13	-53.80

Antenna Polarity & Test Distance: Vertical at 3 M

No.	Freq. (MHz)	Reading (dB μ V/m)	Correction Factor (dB)	EIRP (dBm)	Limit (dBm)	Margin (dB)
1	66.89	37.18	-95.26	-58.08	-13	-45.08
2	91.78	39.55	-95.26	-55.71	-13	-42.71
3	163.91	29.96	-95.26	-65.30	-13	-52.30
4	204	28.31	-95.26	-66.95	-13	-53.95
5	228.67	35.06	-95.26	-60.20	-13	-47.20
6	856.19	32.51	-95.26	-62.75	-13	-49.75

Remarks:

1. Follow ANSI 63.26 section 5.2.7 d), EIRP Value (dBm) = E (dB μ V/m) - Correction Factor @ 3m.
2. Correction Factor (dB) = $20\log(D) - 104.8$; where D is the measurement distance @ 3m.

LTE Band 4: 5MHz

Mode	TX channel 19975	Frequency Range	Below 1000 MHz
------	------------------	-----------------	----------------

Antenna Polarity & Test Distance: Horizontal at 3 M

No.	Freq. (MHz)	Reading (dB μ V/m)	Correction Factor (dB)	EIRP (dBm)	Limit (dBm)	Margin (dB)
1	223.04	36.53	-95.26	-58.73	-13	-45.73
2	249.77	35.2	-95.26	-60.06	-13	-47.06
3	305.99	27.37	-95.26	-67.89	-13	-54.89
4	310.38	35.58	-95.26	-59.68	-13	-46.68
5	770.71	35.04	-95.26	-60.22	-13	-47.22
6	914.22	30.3	-95.26	-64.96	-13	-51.96

Antenna Polarity & Test Distance: Vertical at 3 M

No.	Freq. (MHz)	Reading (dB μ V/m)	Correction Factor (dB)	EIRP (dBm)	Limit (dBm)	Margin (dB)
1	67.64	36.31	-95.26	-58.95	-13	-45.95
2	99.56	35.67	-95.26	-59.59	-13	-46.59
3	169.75	32.75	-95.26	-62.51	-13	-49.51
4	205.75	26.13	-95.26	-69.13	-13	-56.13
5	228.97	35.56	-95.26	-59.70	-13	-46.70
6	858.33	31.44	-95.26	-63.82	-13	-50.82

Remarks:

1. Follow ANSI 63.26 section 5.2.7 d), EIRP Value (dBm) = E (dB μ V/m) - Correction Factor @ 3m.
2. Correction Factor (dB) = $20\log(D) - 104.8$; where D is the measurement distance @ 3m.

Mode	TX channel 20175	Frequency Range	Below 1000 MHz
------	------------------	-----------------	----------------

Antenna Polarity & Test Distance: Horizontal at 3 M

No.	Freq. (MHz)	Reading (dB μ V/m)	Correction Factor (dB)	EIRP (dBm)	Limit (dBm)	Margin (dB)
1	227.76	33	-95.26	-62.26	-13	-49.26
2	255.56	32.97	-95.26	-62.29	-13	-49.29
3	306.47	27.23	-95.26	-68.03	-13	-55.03
4	314.13	37.67	-95.26	-57.59	-13	-44.59
5	772.78	34.02	-95.26	-61.24	-13	-48.24
6	918.29	32.98	-95.26	-62.28	-13	-49.28

Antenna Polarity & Test Distance: Vertical at 3 M

No.	Freq. (MHz)	Reading (dB μ V/m)	Correction Factor (dB)	EIRP (dBm)	Limit (dBm)	Margin (dB)
1	69.5	35.19	-95.26	-60.07	-13	-47.07
2	105.01	36.54	-95.26	-58.72	-13	-45.72
3	169.93	31.54	-95.26	-63.72	-13	-50.72
4	213.21	25.66	-95.26	-69.60	-13	-56.60
5	232.82	35.23	-95.26	-60.03	-13	-47.03
6	860.16	34.8	-95.26	-60.46	-13	-47.46

Remarks:

1. Follow ANSI 63.26 section 5.2.7 d), EIRP Value (dBm) = E (dB μ V/m) - Correction Factor @ 3m.
2. Correction Factor (dB) = 20log(D) - 104.8; where D is the measurement distance @ 3m.

Mode	TX channel 20375	Frequency Range	Below 1000 MHz
------	------------------	-----------------	----------------

Antenna Polarity & Test Distance: Horizontal at 3 M

No.	Freq. (MHz)	Reading (dB μ V/m)	Correction Factor (dB)	EIRP (dBm)	Limit (dBm)	Margin (dB)
1	230.42	36.48	-95.26	-58.78	-13	-45.78
2	258.36	36.9	-95.26	-58.36	-13	-45.36
3	314.37	26.44	-95.26	-68.82	-13	-55.82
4	322	33.89	-95.26	-61.37	-13	-48.37
5	778.58	32.54	-95.26	-62.72	-13	-49.72
6	925.13	28.17	-95.26	-67.09	-13	-54.09

Antenna Polarity & Test Distance: Vertical at 3 M

No.	Freq. (MHz)	Reading (dB μ V/m)	Correction Factor (dB)	EIRP (dBm)	Limit (dBm)	Margin (dB)
1	72.33	33.77	-95.26	-61.49	-13	-48.49
2	107.31	39.22	-95.26	-56.04	-13	-43.04
3	171.41	32.53	-95.26	-62.73	-13	-49.73
4	217.16	23.59	-95.26	-71.67	-13	-58.67
5	239.19	34.77	-95.26	-60.49	-13	-47.49
6	861.31	30.02	-95.26	-65.24	-13	-52.24

Remarks:

1. Follow ANSI 63.26 section 5.2.7 d), EIRP Value (dBm) = E (dB μ V/m) - Correction Factor @ 3m.
2. Correction Factor (dB) = 20log(D) - 104.8; where D is the measurement distance @ 3m.

LTE Band 4: 10MHz

Mode	TX channel 20000	Frequency Range	Below 1000 MHz
------	------------------	-----------------	----------------

Antenna Polarity & Test Distance: Horizontal at 3 M

No.	Freq. (MHz)	Reading (dB μ V/m)	Correction Factor (dB)	EIRP (dBm)	Limit (dBm)	Margin (dB)
1	231.82	34.13	-95.26	-61.13	-13	-48.13
2	258.78	33.88	-95.26	-61.38	-13	-48.38
3	317.7	32.02	-95.26	-63.24	-13	-50.24
4	329.94	36.94	-95.26	-58.32	-13	-45.32
5	781.99	34.55	-95.26	-60.71	-13	-47.71
6	933.18	30.75	-95.26	-64.51	-13	-51.51

Antenna Polarity & Test Distance: Vertical at 3 M

No.	Freq. (MHz)	Reading (dB μ V/m)	Correction Factor (dB)	EIRP (dBm)	Limit (dBm)	Margin (dB)
1	78.95	36.84	-95.26	-58.42	-13	-45.42
2	115.08	39.78	-95.26	-55.48	-13	-42.48
3	174.31	32.93	-95.26	-62.33	-13	-49.33
4	218.88	26.92	-95.26	-68.34	-13	-55.34
5	242.74	33.72	-95.26	-61.54	-13	-48.54
6	862.16	31.69	-95.26	-63.57	-13	-50.57

Remarks:

1. Follow ANSI 63.26 section 5.2.7 d), EIRP Value (dBm) = E (dB μ V/m) - Correction Factor @ 3m.
2. Correction Factor (dB) = $20\log(D) - 104.8$; where D is the measurement distance @ 3m.

Mode	TX channel 20175	Frequency Range	Below 1000 MHz
------	------------------	-----------------	----------------

Antenna Polarity & Test Distance: Horizontal at 3 M

No.	Freq. (MHz)	Reading (dB μ V/m)	Correction Factor (dB)	EIRP (dBm)	Limit (dBm)	Margin (dB)
1	233.7	31.61	-95.26	-63.65	-13	-50.65
2	266.16	36.29	-95.26	-58.97	-13	-45.97
3	324.2	25.18	-95.26	-70.08	-13	-57.08
4	331.79	32.48	-95.26	-62.78	-13	-49.78
5	784.94	31.1	-95.26	-64.16	-13	-51.16
6	937.24	28.76	-95.26	-66.50	-13	-53.50

Antenna Polarity & Test Distance: Vertical at 3 M

No.	Freq. (MHz)	Reading (dB μ V/m)	Correction Factor (dB)	EIRP (dBm)	Limit (dBm)	Margin (dB)
1	84.88	33.83	-95.26	-61.43	-13	-48.43
2	121.85	35.64	-95.26	-59.62	-13	-46.62
3	179.56	31.03	-95.26	-64.23	-13	-51.23
4	223.57	26.1	-95.26	-69.16	-13	-56.16
5	242.78	33.09	-95.26	-62.17	-13	-49.17
6	870.37	30.74	-95.26	-64.52	-13	-51.52

Remarks:

1. Follow ANSI 63.26 section 5.2.7 d), EIRP Value (dBm) = E (dB μ V/m) - Correction Factor @ 3m.
2. Correction Factor (dB) = 20log(D) - 104.8; where D is the measurement distance @ 3m.

Mode	TX channel 20350	Frequency Range	Below 1000 MHz
------	------------------	-----------------	----------------

Antenna Polarity & Test Distance: Horizontal at 3 M

No.	Freq. (MHz)	Reading (dB μ V/m)	Correction Factor (dB)	EIRP (dBm)	Limit (dBm)	Margin (dB)
1	240.72	35.72	-95.26	-59.54	-13	-46.54
2	270.46	39.26	-95.26	-56.00	-13	-43.00
3	324.14	29.26	-95.26	-66.00	-13	-53.00
4	337.33	35.57	-95.26	-59.69	-13	-46.69
5	789.88	32.92	-95.26	-62.34	-13	-49.34
6	939.61	29.41	-95.26	-65.85	-13	-52.85

Antenna Polarity & Test Distance: Vertical at 3 M

No.	Freq. (MHz)	Reading (dB μ V/m)	Correction Factor (dB)	EIRP (dBm)	Limit (dBm)	Margin (dB)
1	91.36	34.76	-95.26	-60.50	-13	-47.50
2	123.1	35.82	-95.26	-59.44	-13	-46.44
3	184.25	32.11	-95.26	-63.15	-13	-50.15
4	229.63	28.21	-95.26	-67.05	-13	-54.05
5	245.17	33.89	-95.26	-61.37	-13	-48.37
6	876.94	34.47	-95.26	-60.79	-13	-47.79

Remarks:

1. Follow ANSI 63.26 section 5.2.7 d), EIRP Value (dBm) = E (dB μ V/m) - Correction Factor @ 3m.
2. Correction Factor (dB) = $20\log(D) - 104.8$; where D is the measurement distance @ 3m.

LTE Band 4: 15MHz

Mode	TX channel 20025	Frequency Range	Below 1000 MHz
------	------------------	-----------------	----------------

Antenna Polarity & Test Distance: Horizontal at 3 M

No.	Freq. (MHz)	Reading (dB μ V/m)	Correction Factor (dB)	EIRP (dBm)	Limit (dBm)	Margin (dB)
1	188.62	31.19	-95.26	-64.07	-13	-51.07
2	234.37	36.9	-95.26	-58.36	-13	-45.36
3	267.39	29.13	-95.26	-66.13	-13	-53.13
4	295.76	33.61	-95.26	-61.65	-13	-48.65
5	755.13	31.53	-95.26	-63.73	-13	-50.73
6	899.72	31.7	-95.26	-63.56	-13	-50.56

Antenna Polarity & Test Distance: Vertical at 3 M

No.	Freq. (MHz)	Reading (dB μ V/m)	Correction Factor (dB)	EIRP (dBm)	Limit (dBm)	Margin (dB)
1	53.76	36.13	-95.26	-59.13	-13	-46.13
2	71.91	36.42	-95.26	-58.84	-13	-45.84
3	146.72	30.15	-95.26	-65.11	-13	-52.11
4	184.36	29.48	-95.26	-65.78	-13	-52.78
5	208.64	36	-95.26	-59.26	-13	-46.26
6	831.65	34.67	-95.26	-60.59	-13	-47.59

Remarks:

1. Follow ANSI 63.26 section 5.2.7 d), EIRP Value (dBm) = E (dB μ V/m) - Correction Factor @ 3m.
2. Correction Factor (dB) = $20\log(D) - 104.8$; where D is the measurement distance @ 3m.

Mode	TX channel 20175	Frequency Range	Below 1000 MHz
------	------------------	-----------------	----------------

Antenna Polarity & Test Distance: Horizontal at 3 M

No.	Freq. (MHz)	Reading (dB μ V/m)	Correction Factor (dB)	EIRP (dBm)	Limit (dBm)	Margin (dB)
1	195.53	32.37	-95.26	-62.89	-13	-49.89
2	239.45	34.13	-95.26	-61.13	-13	-48.13
3	274.17	26.47	-95.26	-68.79	-13	-55.79
4	302.48	35.78	-95.26	-59.48	-13	-46.48
5	761.01	34.86	-95.26	-60.40	-13	-47.40
6	903.89	27.84	-95.26	-67.42	-13	-54.42

Antenna Polarity & Test Distance: Vertical at 3 M

No.	Freq. (MHz)	Reading (dB μ V/m)	Correction Factor (dB)	EIRP (dBm)	Limit (dBm)	Margin (dB)
1	57.33	36.66	-95.26	-58.60	-13	-45.60
2	79.64	37.71	-95.26	-57.55	-13	-44.55
3	150.09	32.45	-95.26	-62.81	-13	-49.81
4	189.73	27.25	-95.26	-68.01	-13	-55.01
5	214.58	32.33	-95.26	-62.93	-13	-49.93
6	838.16	33.5	-95.26	-61.76	-13	-48.76

Remarks:

1. Follow ANSI 63.26 section 5.2.7 d), EIRP Value (dBm) = E (dB μ V/m) - Correction Factor @ 3m.
2. Correction Factor (dB) = $20\log(D) - 104.8$; where D is the measurement distance @ 3m.

Mode	TX channel 20325	Frequency Range	Below 1000 MHz
------	------------------	-----------------	----------------

Antenna Polarity & Test Distance: Horizontal at 3 M

No.	Freq. (MHz)	Reading (dB μ V/m)	Correction Factor (dB)	EIRP (dBm)	Limit (dBm)	Margin (dB)
1	200.56	34.7	-95.26	-60.56	-13	-47.56
2	246.44	35.27	-95.26	-59.99	-13	-46.99
3	280.11	31.14	-95.26	-64.12	-13	-51.12
4	308.49	36.33	-95.26	-58.93	-13	-45.93
5	764.66	30.82	-95.26	-64.44	-13	-51.44
6	908.64	27.17	-95.26	-68.09	-13	-55.09

Antenna Polarity & Test Distance: Vertical at 3 M

No.	Freq. (MHz)	Reading (dB μ V/m)	Correction Factor (dB)	EIRP (dBm)	Limit (dBm)	Margin (dB)
1	59.01	34.71	-95.26	-60.55	-13	-47.55
2	80.7	37.9	-95.26	-57.36	-13	-44.36
3	154.16	32.21	-95.26	-63.05	-13	-50.05
4	194.04	25.98	-95.26	-69.28	-13	-56.28
5	218.44	36.97	-95.26	-58.29	-13	-45.29
6	841.39	33.66	-95.26	-61.60	-13	-48.60

Remarks:

1. Follow ANSI 63.26 section 5.2.7 d), EIRP Value (dBm) = E (dB μ V/m) - Correction Factor @ 3m.
2. Correction Factor (dB) = $20\log(D) - 104.8$; where D is the measurement distance @ 3m.

LTE Band 4: 20MHz

Mode	TX channel 20050	Frequency Range	Below 1000 MHz
------	------------------	-----------------	----------------

Antenna Polarity & Test Distance: Horizontal at 3 M

No.	Freq. (MHz)	Reading (dB μ V/m)	Correction Factor (dB)	EIRP (dBm)	Limit (dBm)	Margin (dB)
1	193.39	34.66	-95.26	-60.60	-13	-47.60
2	242.69	33.86	-95.26	-61.40	-13	-48.40
3	269.22	26.46	-95.26	-68.80	-13	-55.80
4	293.47	33.14	-95.26	-62.12	-13	-49.12
5	756.07	29.3	-95.26	-65.96	-13	-52.96
6	897.68	31.4	-95.26	-63.86	-13	-50.86

Antenna Polarity & Test Distance: Vertical at 3 M

No.	Freq. (MHz)	Reading (dB μ V/m)	Correction Factor (dB)	EIRP (dBm)	Limit (dBm)	Margin (dB)
1	51.12	34.1	-95.26	-61.16	-13	-48.16
2	67.5	35.18	-95.26	-60.08	-13	-47.08
3	148.79	34.79	-95.26	-60.47	-13	-47.47
4	184.56	29.16	-95.26	-66.10	-13	-53.10
5	210.42	34.82	-95.26	-60.44	-13	-47.44
6	838.49	34.7	-95.26	-60.56	-13	-47.56

Remarks:

1. Follow ANSI 63.26 section 5.2.7 d), EIRP Value (dBm) = E (dB μ V/m) - Correction Factor @ 3m.
2. Correction Factor (dB) = 20log(D) - 104.8; where D is the measurement distance @ 3m.

Mode	TX channel 20175	Frequency Range	Below 1000 MHz
------	------------------	-----------------	----------------

Antenna Polarity & Test Distance: Horizontal at 3 M

No.	Freq. (MHz)	Reading (dB μ V/m)	Correction Factor (dB)	EIRP (dBm)	Limit (dBm)	Margin (dB)
1	193.35	33.4	-95.26	-61.86	-13	-48.86
2	247.45	36.82	-95.26	-58.44	-13	-45.44
3	273.98	25.75	-95.26	-69.51	-13	-56.51
4	298.47	35.13	-95.26	-60.13	-13	-47.13
5	761.19	31.51	-95.26	-63.75	-13	-50.75
6	905.67	28.75	-95.26	-66.51	-13	-53.51

Antenna Polarity & Test Distance: Vertical at 3 M

No.	Freq. (MHz)	Reading (dB μ V/m)	Correction Factor (dB)	EIRP (dBm)	Limit (dBm)	Margin (dB)
1	57.23	34.31	-95.26	-60.95	-13	-47.95
2	75.12	35.84	-95.26	-59.42	-13	-46.42
3	157	30.36	-95.26	-64.90	-13	-51.90
4	187.94	25.16	-95.26	-70.10	-13	-57.10
5	211.5	33.84	-95.26	-61.42	-13	-48.42
6	843.77	36.45	-95.26	-58.81	-13	-45.81

Remarks:

1. Follow ANSI 63.26 section 5.2.7 d), EIRP Value (dBm) = E (dB μ V/m) - Correction Factor @ 3m.
2. Correction Factor (dB) = $20\log(D) - 104.8$; where D is the measurement distance @ 3m.

Mode	TX channel 20300	Frequency Range	Below 1000 MHz
------	------------------	-----------------	----------------

Antenna Polarity & Test Distance: Horizontal at 3 M

No.	Freq. (MHz)	Reading (dB μ V/m)	Correction Factor (dB)	EIRP (dBm)	Limit (dBm)	Margin (dB)
1	197.21	32.29	-95.26	-62.97	-13	-49.97
2	248.02	36.56	-95.26	-58.70	-13	-45.70
3	276.61	27.17	-95.26	-68.09	-13	-55.09
4	303.32	35.82	-95.26	-59.44	-13	-46.44
5	768.77	32.96	-95.26	-62.30	-13	-49.30
6	910.15	29.45	-95.26	-65.81	-13	-52.81

Antenna Polarity & Test Distance: Vertical at 3 M

No.	Freq. (MHz)	Reading (dB μ V/m)	Correction Factor (dB)	EIRP (dBm)	Limit (dBm)	Margin (dB)
1	63.71	34.73	-95.26	-60.53	-13	-47.53
2	75.94	35.06	-95.26	-60.20	-13	-47.20
3	157.22	33.73	-95.26	-61.53	-13	-48.53
4	193.9	24.89	-95.26	-70.37	-13	-57.37
5	215.25	35.2	-95.26	-60.06	-13	-47.06
6	849.86	32.13	-95.26	-63.13	-13	-50.13

Remarks:

1. Follow ANSI 63.26 section 5.2.7 d), EIRP Value (dBm) = E (dB μ V/m) - Correction Factor @ 3m.
2. Correction Factor (dB) = $20\log(D) - 104.8$; where D is the measurement distance @ 3m.

LTE Band 12: 1.4MHz

Mode	TX channel 23017	Frequency Range	Below 1000 MHz
------	------------------	-----------------	----------------

Antenna Polarity & Test Distance: Horizontal at 3 M

No.	Freq. (MHz)	Reading (dB μ V/m)	Correction Factor (dB)	EIRP (dBm)	Limit (dBm)	Margin (dB)
1	188.78	34.43	-95.26	-60.83	-13	-47.83
2	238.82	34.89	-95.26	-60.37	-13	-47.37
3	269.23	26.49	-95.26	-68.77	-13	-55.77
4	299.63	32.41	-95.26	-62.85	-13	-49.85
5	751.96	33.35	-95.26	-61.91	-13	-48.91
6	910.27	32.68	-95.26	-62.58	-13	-49.58

Antenna Polarity & Test Distance: Vertical at 3 M

No.	Freq. (MHz)	Reading (dB μ V/m)	Correction Factor (dB)	EIRP (dBm)	Limit (dBm)	Margin (dB)
1	63.63	33.79	-95.26	-61.47	-13	-48.47
2	74.46	37.01	-95.26	-58.25	-13	-45.25
3	149.45	28.5	-95.26	-66.76	-13	-53.76
4	189.01	26.96	-95.26	-68.30	-13	-55.30
5	214.98	31.38	-95.26	-63.88	-13	-50.88
6	845.15	30.67	-95.26	-64.59	-13	-51.59

Remarks:

1. Follow ANSI 63.26 section 5.2.7 d), EIRP Value (dBm) = E (dB μ V/m) - Correction Factor @ 3m.
2. Correction Factor (dB) = $20\log(D) - 104.8$; where D is the measurement distance @ 3m.

Mode	TX channel 23095	Frequency Range	Below 1000 MHz
------	------------------	-----------------	----------------

Antenna Polarity & Test Distance: Horizontal at 3 M

No.	Freq. (MHz)	Reading (dB μ V/m)	Correction Factor (dB)	EIRP (dBm)	Limit (dBm)	Margin (dB)
1	190.1	33.26	-95.26	-62.00	-13	-49.00
2	240.14	37.46	-95.26	-57.80	-13	-44.80
3	269.87	30.54	-95.26	-64.72	-13	-51.72
4	301.93	32.18	-95.26	-63.08	-13	-50.08
5	760.06	32.17	-95.26	-63.09	-13	-50.09
6	914.48	28.52	-95.26	-66.74	-13	-53.74

Antenna Polarity & Test Distance: Vertical at 3 M

No.	Freq. (MHz)	Reading (dB μ V/m)	Correction Factor (dB)	EIRP (dBm)	Limit (dBm)	Margin (dB)
1	70.9	34.83	-95.26	-60.43	-13	-47.43
2	78.73	34.39	-95.26	-60.87	-13	-47.87
3	154.09	31.96	-95.26	-63.30	-13	-50.30
4	190.36	29.16	-95.26	-66.10	-13	-53.10
5	218.26	34.47	-95.26	-60.79	-13	-47.79
6	847.09	34.2	-95.26	-61.06	-13	-48.06

Remarks:

1. Follow ANSI 63.26 section 5.2.7 d), EIRP Value (dBm) = E (dB μ V/m) - Correction Factor @ 3m.
2. Correction Factor (dB) = $20\log(D) - 104.8$; where D is the measurement distance @ 3m.

Mode	TX channel 23173	Frequency Range	Below 1000 MHz
------	------------------	-----------------	----------------

Antenna Polarity & Test Distance: Horizontal at 3 M

No.	Freq. (MHz)	Reading (dB μ V/m)	Correction Factor (dB)	EIRP (dBm)	Limit (dBm)	Margin (dB)
1	197.59	33.14	-95.26	-62.12	-13	-49.12
2	241.03	34.82	-95.26	-60.44	-13	-47.44
3	271.76	29.66	-95.26	-65.60	-13	-52.60
4	305.47	34.31	-95.26	-60.95	-13	-47.95
5	759.81	31.74	-95.26	-63.52	-13	-50.52
6	915.19	30.07	-95.26	-65.19	-13	-52.19

Antenna Polarity & Test Distance: Vertical at 3 M

No.	Freq. (MHz)	Reading (dB μ V/m)	Correction Factor (dB)	EIRP (dBm)	Limit (dBm)	Margin (dB)
1	74.95	39	-95.26	-56.26	-13	-43.26
2	78.67	34.14	-95.26	-61.12	-13	-48.12
3	158.81	32.5	-95.26	-62.76	-13	-49.76
4	194.57	28.28	-95.26	-66.98	-13	-53.98
5	217.8	37.26	-95.26	-58.00	-13	-45.00
6	850.48	35.17	-95.26	-60.09	-13	-47.09

Remarks:

1. Follow ANSI 63.26 section 5.2.7 d), EIRP Value (dBm) = E (dB μ V/m) - Correction Factor @ 3m.
2. Correction Factor (dB) = $20\log(D) - 104.8$; where D is the measurement distance @ 3m.

LTE Band 12: 3MHz

Mode	TX channel 23025	Frequency Range	Below 1000 MHz
------	------------------	-----------------	----------------

Antenna Polarity & Test Distance: Horizontal at 3 M

No.	Freq. (MHz)	Reading (dB μ V/m)	Correction Factor (dB)	EIRP (dBm)	Limit (dBm)	Margin (dB)
1	200.15	35.23	-95.26	-60.03	-13	-47.03
2	248.92	36.09	-95.26	-59.17	-13	-46.17
3	275.78	31.21	-95.26	-64.05	-13	-51.05
4	306.09	33.23	-95.26	-62.03	-13	-49.03
5	760.6	32.59	-95.26	-62.67	-13	-49.67
6	921.38	29.32	-95.26	-65.94	-13	-52.94

Antenna Polarity & Test Distance: Vertical at 3 M

No.	Freq. (MHz)	Reading (dB μ V/m)	Correction Factor (dB)	EIRP (dBm)	Limit (dBm)	Margin (dB)
1	81.98	34.36	-95.26	-60.90	-13	-47.90
2	79.41	33.85	-95.26	-61.41	-13	-48.41
3	158.41	29.97	-95.26	-65.29	-13	-52.29
4	201.61	23.97	-95.26	-71.29	-13	-58.29
5	222.58	33.75	-95.26	-61.51	-13	-48.51
6	854.41	30.69	-95.26	-64.57	-13	-51.57

Remarks:

1. Follow ANSI 63.26 section 5.2.7 d), EIRP Value (dBm) = E (dB μ V/m) - Correction Factor @ 3m.
2. Correction Factor (dB) = $20\log(D) - 104.8$; where D is the measurement distance @ 3m.

Mode	TX channel 23095	Frequency Range	Below 1000 MHz
------	------------------	-----------------	----------------

Antenna Polarity & Test Distance: Horizontal at 3 M

No.	Freq. (MHz)	Reading (dB μ V/m)	Correction Factor (dB)	EIRP (dBm)	Limit (dBm)	Margin (dB)
1	200.75	38.02	-95.26	-57.24	-13	-44.24
2	253.55	36.07	-95.26	-59.19	-13	-46.19
3	276.09	29.09	-95.26	-66.17	-13	-53.17
4	309.52	30.69	-95.26	-64.57	-13	-51.57
5	765.67	31.58	-95.26	-63.68	-13	-50.68
6	922.99	33.59	-95.26	-61.67	-13	-48.67

Antenna Polarity & Test Distance: Vertical at 3 M

No.	Freq. (MHz)	Reading (dB μ V/m)	Correction Factor (dB)	EIRP (dBm)	Limit (dBm)	Margin (dB)
1	90.16	32.41	-95.26	-62.85	-13	-49.85
2	83.6	32.94	-95.26	-62.32	-13	-49.32
3	166.65	32.8	-95.26	-62.46	-13	-49.46
4	207.91	24.38	-95.26	-70.88	-13	-57.88
5	227.13	35.2	-95.26	-60.06	-13	-47.06
6	859.36	30.04	-95.26	-65.22	-13	-52.22

Remarks:

1. Follow ANSI 63.26 section 5.2.7 d), EIRP Value (dBm) = E (dB μ V/m) - Correction Factor @ 3m.
2. Correction Factor (dB) = 20log(D) - 104.8; where D is the measurement distance @ 3m.

Mode	TX channel 23165	Frequency Range	Below 1000 MHz
------	------------------	-----------------	----------------

Antenna Polarity & Test Distance: Horizontal at 3 M

No.	Freq. (MHz)	Reading (dB μ V/m)	Correction Factor (dB)	EIRP (dBm)	Limit (dBm)	Margin (dB)
1	204.45	32.87	-95.26	-62.39	-13	-49.39
2	255.31	38.54	-95.26	-56.72	-13	-43.72
3	276.34	26.49	-95.26	-68.77	-13	-55.77
4	310.92	34.92	-95.26	-60.34	-13	-47.34
5	766.77	34.23	-95.26	-61.03	-13	-48.03
6	930.27	29.13	-95.26	-66.13	-13	-53.13

Antenna Polarity & Test Distance: Vertical at 3 M

No.	Freq. (MHz)	Reading (dB μ V/m)	Correction Factor (dB)	EIRP (dBm)	Limit (dBm)	Margin (dB)
1	95.62	33.75	-95.26	-61.51	-13	-48.51
2	88.43	32.39	-95.26	-62.87	-13	-49.87
3	171.27	32.61	-95.26	-62.65	-13	-49.65
4	208.33	25.98	-95.26	-69.28	-13	-56.28
5	227.29	32.97	-95.26	-62.29	-13	-49.29
6	859.58	30.3	-95.26	-64.96	-13	-51.96

Remarks:

1. Follow ANSI 63.26 section 5.2.7 d), EIRP Value (dBm) = E (dB μ V/m) - Correction Factor @ 3m.
2. Correction Factor (dB) = 20log(D) - 104.8; where D is the measurement distance @ 3m.

LTE Band 12: 5MHz

Mode	TX channel 23035	Frequency Range	Below 1000 MHz
------	------------------	-----------------	----------------

Antenna Polarity & Test Distance: Horizontal at 3 M

No.	Freq. (MHz)	Reading (dB μ V/m)	Correction Factor (dB)	EIRP (dBm)	Limit (dBm)	Margin (dB)
1	209.18	35.15	-95.26	-60.11	-13	-47.11
2	259.92	35.64	-95.26	-59.62	-13	-46.62
3	279.64	27.25	-95.26	-68.01	-13	-55.01
4	312.93	35.51	-95.26	-59.75	-13	-46.75
5	772.94	32.12	-95.26	-63.14	-13	-50.14
6	933.72	30.09	-95.26	-65.17	-13	-52.17

Antenna Polarity & Test Distance: Vertical at 3 M

No.	Freq. (MHz)	Reading (dB μ V/m)	Correction Factor (dB)	EIRP (dBm)	Limit (dBm)	Margin (dB)
1	98.5	38.38	-95.26	-56.88	-13	-43.88
2	88.2	34.89	-95.26	-60.37	-13	-47.37
3	178.65	29.08	-95.26	-66.18	-13	-53.18
4	213.55	23.92	-95.26	-71.34	-13	-58.34
5	234.45	34.87	-95.26	-60.39	-13	-47.39
6	862.68	33.42	-95.26	-61.84	-13	-48.84

Remarks:

1. Follow ANSI 63.26 section 5.2.7 d), EIRP Value (dBm) = E (dB μ V/m) - Correction Factor @ 3m.
2. Correction Factor (dB) = $20\log(D) - 104.8$; where D is the measurement distance @ 3m.

Mode	TX channel 23095	Frequency Range	Below 1000 MHz
------	------------------	-----------------	----------------

Antenna Polarity & Test Distance: Horizontal at 3 M

No.	Freq. (MHz)	Reading (dB μ V/m)	Correction Factor (dB)	EIRP (dBm)	Limit (dBm)	Margin (dB)
1	214.49	34.83	-95.26	-60.43	-13	-47.43
2	265.28	37.45	-95.26	-57.81	-13	-44.81
3	287.18	31.18	-95.26	-64.08	-13	-51.08
4	314.97	35.48	-95.26	-59.78	-13	-46.78
5	773.25	31.62	-95.26	-63.64	-13	-50.64
6	940.56	29.44	-95.26	-65.82	-13	-52.82

Antenna Polarity & Test Distance: Vertical at 3 M

No.	Freq. (MHz)	Reading (dB μ V/m)	Correction Factor (dB)	EIRP (dBm)	Limit (dBm)	Margin (dB)
1	106.76	37.91	-95.26	-57.35	-13	-44.35
2	96.19	33.88	-95.26	-61.38	-13	-48.38
3	185.38	31.76	-95.26	-63.50	-13	-50.50
4	215.89	28.08	-95.26	-67.18	-13	-54.18
5	236.89	35.87	-95.26	-59.39	-13	-46.39
6	866.02	34.41	-95.26	-60.85	-13	-47.85

Remarks:

1. Follow ANSI 63.26 section 5.2.7 d), EIRP Value (dBm) = E (dB μ V/m) - Correction Factor @ 3m.
2. Correction Factor (dB) = $20\log(D) - 104.8$; where D is the measurement distance @ 3m.

Mode	TX channel 23155	Frequency Range	Below 1000 MHz
------	------------------	-----------------	----------------

Antenna Polarity & Test Distance: Horizontal at 3 M

No.	Freq. (MHz)	Reading (dB μ V/m)	Correction Factor (dB)	EIRP (dBm)	Limit (dBm)	Margin (dB)
1	215.48	31.76	-95.26	-63.50	-13	-50.50
2	269.84	34.29	-95.26	-60.97	-13	-47.97
3	292.39	29.37	-95.26	-65.89	-13	-52.89
4	316.3	31.76	-95.26	-63.50	-13	-50.50
5	780.22	31.97	-95.26	-63.29	-13	-50.29
6	944.07	33.19	-95.26	-62.07	-13	-49.07

Antenna Polarity & Test Distance: Vertical at 3 M

No.	Freq. (MHz)	Reading (dB μ V/m)	Correction Factor (dB)	EIRP (dBm)	Limit (dBm)	Margin (dB)
1	109.88	37.53	-95.26	-57.73	-13	-44.73
2	102.07	38.02	-95.26	-57.24	-13	-44.24
3	188.79	30.17	-95.26	-65.09	-13	-52.09
4	223.54	23.97	-95.26	-71.29	-13	-58.29
5	241.22	36.41	-95.26	-58.85	-13	-45.85
6	869.18	32.4	-95.26	-62.86	-13	-49.86

Remarks:

1. Follow ANSI 63.26 section 5.2.7 d), EIRP Value (dBm) = E (dB μ V/m) - Correction Factor @ 3m.
2. Correction Factor (dB) = $20\log(D) - 104.8$; where D is the measurement distance @ 3m.

LTE Band 12: 10MHz

Mode	TX channel 23060	Frequency Range	Below 1000 MHz
------	------------------	-----------------	----------------

Antenna Polarity & Test Distance: Horizontal at 3 M

No.	Freq. (MHz)	Reading (dB μ V/m)	Correction Factor (dB)	EIRP (dBm)	Limit (dBm)	Margin (dB)
1	188.67	34.65	-95.26	-60.61	-13	-47.61
2	235.85	36.74	-95.26	-58.52	-13	-45.52
3	266.23	27.95	-95.26	-67.31	-13	-54.31
4	291.75	34.35	-95.26	-60.91	-13	-47.91
5	751.42	32.01	-95.26	-63.25	-13	-50.25
6	905.37	31.86	-95.26	-63.40	-13	-50.40

Antenna Polarity & Test Distance: Vertical at 3 M

No.	Freq. (MHz)	Reading (dB μ V/m)	Correction Factor (dB)	EIRP (dBm)	Limit (dBm)	Margin (dB)
1	55.43	36.84	-95.26	-58.42	-13	-45.42
2	72.88	33.92	-95.26	-61.34	-13	-48.34
3	142.95	30.13	-95.26	-65.13	-13	-52.13
4	183.91	23.22	-95.26	-72.04	-13	-59.04
5	210.53	35.04	-95.26	-60.22	-13	-47.22
6	837.04	35.19	-95.26	-60.07	-13	-47.07

Remarks:

1. Follow ANSI 63.26 section 5.2.7 d), EIRP Value (dBm) = E (dB μ V/m) - Correction Factor @ 3m.
2. Correction Factor (dB) = $20\log(D) - 104.8$; where D is the measurement distance @ 3m.

Mode	TX channel 23095	Frequency Range	Below 1000 MHz
------	------------------	-----------------	----------------

Antenna Polarity & Test Distance: Horizontal at 3 M

No.	Freq. (MHz)	Reading (dB μ V/m)	Correction Factor (dB)	EIRP (dBm)	Limit (dBm)	Margin (dB)
1	191.92	34.13	-95.26	-61.13	-13	-48.13
2	243.87	38.44	-95.26	-56.82	-13	-43.82
3	266.65	32.11	-95.26	-63.15	-13	-50.15
4	295.11	31.25	-95.26	-64.01	-13	-51.01
5	751.1	31.67	-95.26	-63.59	-13	-50.59
6	912.93	29.5	-95.26	-65.76	-13	-52.76

Antenna Polarity & Test Distance: Vertical at 3 M

No.	Freq. (MHz)	Reading (dB μ V/m)	Correction Factor (dB)	EIRP (dBm)	Limit (dBm)	Margin (dB)
1	56.12	33.89	-95.26	-61.37	-13	-48.37
2	80.64	35.83	-95.26	-59.43	-13	-46.43
3	146.82	31.1	-95.26	-64.16	-13	-51.16
4	189.17	24.4	-95.26	-70.86	-13	-57.86
5	217.18	32.66	-95.26	-62.60	-13	-49.60
6	837.86	31.42	-95.26	-63.84	-13	-50.84

Remarks:

1. Follow ANSI 63.26 section 5.2.7 d), EIRP Value (dBm) = E (dB μ V/m) - Correction Factor @ 3m.
2. Correction Factor (dB) = $20\log(D) - 104.8$; where D is the measurement distance @ 3m.

Mode	TX channel 23130	Frequency Range	Below 1000 MHz
------	------------------	-----------------	----------------

Antenna Polarity & Test Distance: Horizontal at 3 M

No.	Freq. (MHz)	Reading (dB μ V/m)	Correction Factor (dB)	EIRP (dBm)	Limit (dBm)	Margin (dB)
1	193.63	34.27	-95.26	-60.99	-13	-47.99
2	249.73	38.77	-95.26	-56.49	-13	-43.49
3	269.24	30.53	-95.26	-64.73	-13	-51.73
4	295.01	33.09	-95.26	-62.17	-13	-49.17
5	753.48	29.78	-95.26	-65.48	-13	-52.48
6	918.17	29.22	-95.26	-66.04	-13	-53.04

Antenna Polarity & Test Distance: Vertical at 3 M

No.	Freq. (MHz)	Reading (dB μ V/m)	Correction Factor (dB)	EIRP (dBm)	Limit (dBm)	Margin (dB)
1	57.57	36.6	-95.26	-58.66	-13	-45.66
2	83.09	33.19	-95.26	-62.07	-13	-49.07
3	146.49	31.6	-95.26	-63.66	-13	-50.66
4	190.03	23.7	-95.26	-71.56	-13	-58.56
5	223.6	32.13	-95.26	-63.13	-13	-50.13
6	838.37	33.33	-95.26	-61.93	-13	-48.93

Remarks:

1. Follow ANSI 63.26 section 5.2.7 d), EIRP Value (dBm) = E (dB μ V/m) - Correction Factor @ 3m.
2. Correction Factor (dB) = 20log(D) - 104.8; where D is the measurement distance @ 3m.

LTE Band 13: 5MHz

Mode	TX channel 23205	Frequency Range	Below 1000 MHz
------	------------------	-----------------	----------------

Antenna Polarity & Test Distance: Horizontal at 3 M

No.	Freq. (MHz)	Reading (dB μ V/m)	Correction Factor (dB)	EIRP (dBm)	Limit (dBm)	Margin (dB)
1	191.19	38.83	-95.26	-56.43	-13	-43.43
2	235.21	37.88	-95.26	-57.38	-13	-44.38
3	264.94	28.73	-95.26	-66.53	-13	-53.53
4	298.29	39.17	-95.26	-56.09	-13	-43.09
5	755.52	33	-95.26	-62.26	-13	-49.26
6	899.51	30.64	-95.26	-64.62	-13	-51.62

Antenna Polarity & Test Distance: Vertical at 3 M

No.	Freq. (MHz)	Reading (dB μ V/m)	Correction Factor (dB)	EIRP (dBm)	Limit (dBm)	Margin (dB)
1	57.23	40.15	-95.26	-55.11	-13	-42.11
2	70.06	34.5	-95.26	-60.76	-13	-47.76
3	143.53	28.21	-95.26	-67.05	-13	-54.05
4	185.33	26.3	-95.26	-68.96	-13	-55.96
5	213.65	36.57	-95.26	-58.69	-13	-45.69
6	838.6	33.1	-95.26	-62.16	-13	-49.16

Remarks:

1. Follow ANSI 63.26 section 5.2.7 d), EIRP Value (dBm) = E (dB μ V/m) - Correction Factor @ 3m.
2. Correction Factor (dB) = 20log(D) - 104.8; where D is the measurement distance @ 3m.

Mode	TX channel 23230	Frequency Range	Below 1000 MHz
------	------------------	-----------------	----------------

Antenna Polarity & Test Distance: Horizontal at 3 M

No.	Freq. (MHz)	Reading (dB μ V/m)	Correction Factor (dB)	EIRP (dBm)	Limit (dBm)	Margin (dB)
1	198.41	36	-95.26	-59.26	-13	-46.26
2	234.92	36.78	-95.26	-58.48	-13	-45.48
3	267.89	34.15	-95.26	-61.11	-13	-48.11
4	304.42	35.18	-95.26	-60.08	-13	-47.08
5	749.99	31.81	-95.26	-63.45	-13	-50.45
6	906.29	30.85	-95.26	-64.41	-13	-51.41

Antenna Polarity & Test Distance: Vertical at 3 M

No.	Freq. (MHz)	Reading (dB μ V/m)	Correction Factor (dB)	EIRP (dBm)	Limit (dBm)	Margin (dB)
1	62.51	41.95	-95.26	-53.31	-13	-40.31
2	73.49	35.67	-95.26	-59.59	-13	-46.59
3	151.93	33.34	-95.26	-61.92	-13	-48.92
4	186.5	32.28	-95.26	-62.98	-13	-49.98
5	217.92	36.29	-95.26	-58.97	-13	-45.97
6	843.87	35.62	-95.26	-59.64	-13	-46.64

Remarks:

1. Follow ANSI 63.26 section 5.2.7 d), EIRP Value (dBm) = E (dB μ V/m) - Correction Factor @ 3m.
2. Correction Factor (dB) = 20log(D) - 104.8; where D is the measurement distance @ 3m.

Mode	TX channel 23255	Frequency Range	Below 1000 MHz
------	------------------	-----------------	----------------

Antenna Polarity & Test Distance: Horizontal at 3 M

No.	Freq. (MHz)	Reading (dB μ V/m)	Correction Factor (dB)	EIRP (dBm)	Limit (dBm)	Margin (dB)
1	201.04	35.83	-95.26	-59.43	-13	-46.43
2	235.88	38	-95.26	-57.26	-13	-44.26
3	270.66	28.46	-95.26	-66.80	-13	-53.80
4	312.91	34.92	-95.26	-60.34	-13	-47.34
5	751.2	31.36	-95.26	-63.90	-13	-50.90
6	910.75	36.8	-95.26	-58.46	-13	-45.46

Antenna Polarity & Test Distance: Vertical at 3 M

No.	Freq. (MHz)	Reading (dB μ V/m)	Correction Factor (dB)	EIRP (dBm)	Limit (dBm)	Margin (dB)
1	69.79	37.86	-95.26	-57.40	-13	-44.40
2	77.33	36.72	-95.26	-58.54	-13	-45.54
3	153.75	33.2	-95.26	-62.06	-13	-49.06
4	193.18	22.75	-95.26	-72.51	-13	-59.51
5	222.01	35.98	-95.26	-59.28	-13	-46.28
6	848.56	34.57	-95.26	-60.69	-13	-47.69

Remarks:

1. Follow ANSI 63.26 section 5.2.7 d), EIRP Value (dBm) = E (dB μ V/m) - Correction Factor @ 3m.
2. Correction Factor (dB) = $20\log(D) - 104.8$; where D is the measurement distance @ 3m.

LTE Band 13: 10MHz

Mode	TX channel 23230	Frequency Range	Below 1000 MHz
------	------------------	-----------------	----------------

Antenna Polarity & Test Distance: Horizontal at 3 M

No.	Freq. (MHz)	Reading (dB μ V/m)	Correction Factor (dB)	EIRP (dBm)	Limit (dBm)	Margin (dB)
1	193.43	38.27	-95.26	-56.99	-13	-43.99
2	238.95	40.47	-95.26	-54.79	-13	-41.79
3	272.15	29.72	-95.26	-65.54	-13	-52.54
4	304.41	36.62	-95.26	-58.64	-13	-45.64
5	755.35	35.88	-95.26	-59.38	-13	-46.38
6	901.62	30.71	-95.26	-64.55	-13	-51.55

Antenna Polarity & Test Distance: Vertical at 3 M

No.	Freq. (MHz)	Reading (dB μ V/m)	Correction Factor (dB)	EIRP (dBm)	Limit (dBm)	Margin (dB)
1	59.48	40.13	-95.26	-55.13	-13	-42.13
2	73.25	32.99	-95.26	-62.27	-13	-49.27
3	147.58	30.39	-95.26	-64.87	-13	-51.87
4	191.57	24.81	-95.26	-70.45	-13	-57.45
5	215.64	36.26	-95.26	-59.00	-13	-46.00
6	841.17	34.1	-95.26	-61.16	-13	-48.16

Remarks:

1. Follow ANSI 63.26 section 5.2.7 d), EIRP Value (dBm) = E (dB μ V/m) - Correction Factor @ 3m.
2. Correction Factor (dB) = 20log(D) - 104.8; where D is the measurement distance @ 3m.

ABOVE 1GHz

LTE Band 4: 1.4MHz

Mode	TX channel 19957	Frequency Range	Above 1000 MHz
------	------------------	-----------------	----------------

Antenna Polarity & Test Distance: Horizontal at 3 M						
No.	Freq. (MHz)	Reading (dB μ V/m)	Correction Factor (dB)	EIRP (dBm)	Limit (dBm)	Margin (dB)
1	3421.4	39.63	-95.26	-55.63	-13	-42.63
2	5132.1	46.02	-95.26	-49.24	-13	-36.24
3	6842.8	53.49	-95.26	-41.77	-13	-28.77
4	8553.5	60.64	-95.26	-34.62	-13	-21.62
Antenna Polarity & Test Distance: Vertical at 3 M						
No.	Freq. (MHz)	Reading (dB μ V/m)	Correction Factor (dB)	EIRP (dBm)	Limit (dBm)	Margin (dB)
1	3421.4	41.2	-95.26	-54.06	-13	-41.06
2	5132.1	50.31	-95.26	-44.95	-13	-31.95
3	6842.8	59.09	-95.26	-36.17	-13	-23.17
4	8553.5	63.12	-95.26	-32.14	-13	-19.14

Remarks:

1. Follow ANSI 63.26 section 5.2.7 d), EIRP Value (dBm) = E (dB μ V/m) - Correction Factor @ 3m.
2. Correction Factor (dB) = 20log(D) - 104.8; where D is the measurement distance @ 3m.

Mode	TX channel 20175	Frequency Range	Above 1000 MHz
------	------------------	-----------------	----------------

Antenna Polarity & Test Distance: Horizontal at 3 M

No.	Freq. (MHz)	Reading (dB μ V/m)	Correction Factor (dB)	EIRP (dBm)	Limit (dBm)	Margin (dB)
1	3465	37.34	-95.26	-57.92	-13	-44.92
2	5197.5	45.83	-95.26	-49.43	-13	-36.43
3	6930	49.39	-95.26	-45.87	-13	-32.87
4	8662.5	63.83	-95.26	-31.43	-13	-18.43

Antenna Polarity & Test Distance: Vertical at 3 M

No.	Freq. (MHz)	Reading (dB μ V/m)	Correction Factor (dB)	EIRP (dBm)	Limit (dBm)	Margin (dB)
1	3465	41.9	-95.26	-53.36	-13	-40.36
2	5197.5	46.18	-95.26	-49.08	-13	-36.08
3	6930	57.62	-95.26	-37.64	-13	-24.64
4	8662.5	64.27	-95.26	-30.99	-13	-17.99

Remarks:

1. Follow ANSI 63.26 section 5.2.7 d), EIRP Value (dBm) = E (dB μ V/m) - Correction Factor @ 3m.
2. Correction Factor (dB) = 20log(D) - 104.8; where D is the measurement distance @ 3m.

Mode	TX channel 20393	Frequency Range	Above 1000 MHz
------	------------------	-----------------	----------------

Antenna Polarity & Test Distance: Horizontal at 3 M

No.	Freq. (MHz)	Reading (dB μ V/m)	Correction Factor (dB)	EIRP (dBm)	Limit (dBm)	Margin (dB)
1	3508.6	38.97	-95.26	-56.29	-13	-43.29
2	5262.9	48.44	-95.26	-46.82	-13	-33.82
3	7017.2	54.23	-95.26	-41.03	-13	-28.03
4	8771.5	63.63	-95.26	-31.63	-13	-18.63

Antenna Polarity & Test Distance: Vertical at 3 M

No.	Freq. (MHz)	Reading (dB μ V/m)	Correction Factor (dB)	EIRP (dBm)	Limit (dBm)	Margin (dB)
1	3508.6	36.25	-95.26	-59.01	-13	-46.01
2	5262.9	49.32	-95.26	-45.94	-13	-32.94
3	7017.2	58.91	-95.26	-36.35	-13	-23.35
4	8771.5	65.1	-95.26	-30.16	-13	-17.16

Remarks:

1. Follow ANSI 63.26 section 5.2.7 d), EIRP Value (dBm) = E (dB μ V/m) - Correction Factor @ 3m.
2. Correction Factor (dB) = 20log(D) - 104.8; where D is the measurement distance @ 3m.

LTE Band 4: 3MHz

Mode	TX channel 19965	Frequency Range	Above 1000 MHz
------	------------------	-----------------	----------------

Antenna Polarity & Test Distance: Horizontal at 3 M

No.	Freq. (MHz)	Reading (dB μ V/m)	Correction Factor (dB)	EIRP (dBm)	Limit (dBm)	Margin (dB)
1	3423	36.7	-95.26	-58.56	-13	-45.56
2	5134.5	44.91	-95.26	-50.35	-13	-37.35
3	6846	53.72	-95.26	-41.54	-13	-28.54
4	8557.5	61.56	-95.26	-33.70	-13	-20.70

Antenna Polarity & Test Distance: Vertical at 3 M

No.	Freq. (MHz)	Reading (dB μ V/m)	Correction Factor (dB)	EIRP (dBm)	Limit (dBm)	Margin (dB)
1	3423	38.04	-95.26	-57.22	-13	-44.22
2	5134.5	47.83	-95.26	-47.43	-13	-34.43
3	6846	57.31	-95.26	-37.95	-13	-24.95
4	8557.5	63.34	-95.26	-31.92	-13	-18.92

Remarks:

1. Follow ANSI 63.26 section 5.2.7 d), EIRP Value (dBm) = E (dB μ V/m) - Correction Factor @ 3m.
2. Correction Factor (dB) = $20\log(D) - 104.8$; where D is the measurement distance @ 3m.

Mode	TX channel 20175	Frequency Range	Above 1000 MHz
------	------------------	-----------------	----------------

Antenna Polarity & Test Distance: Horizontal at 3 M

No.	Freq. (MHz)	Reading (dB μ V/m)	Correction Factor (dB)	EIRP (dBm)	Limit (dBm)	Margin (dB)
1	3465	40.58	-95.26	-54.68	-13	-41.68
2	5197.5	43.93	-95.26	-51.33	-13	-38.33
3	6930	49.4	-95.26	-45.86	-13	-32.86
4	8662.5	63.56	-95.26	-31.70	-13	-18.70

Antenna Polarity & Test Distance: Vertical at 3 M

No.	Freq. (MHz)	Reading (dB μ V/m)	Correction Factor (dB)	EIRP (dBm)	Limit (dBm)	Margin (dB)
1	3465	47.77	-95.26	-47.49	-13	-34.49
2	5197.5	47.64	-95.26	-47.62	-13	-34.62
3	6930	53.99	-95.26	-41.27	-13	-28.27
4	8662.5	65.45	-95.26	-29.81	-13	-16.81

Remarks:

1. Follow ANSI 63.26 section 5.2.7 d), EIRP Value (dBm) = E (dB μ V/m) - Correction Factor @ 3m.
2. Correction Factor (dB) = 20log(D) - 104.8; where D is the measurement distance @ 3m.

Mode	TX channel 20385	Frequency Range	Above 1000 MHz
------	------------------	-----------------	----------------

Antenna Polarity & Test Distance: Horizontal at 3 M

No.	Freq. (MHz)	Reading (dB μ V/m)	Correction Factor (dB)	EIRP (dBm)	Limit (dBm)	Margin (dB)
1	3507	41.51	-95.26	-53.75	-13	-40.75
2	5260.5	45.07	-95.26	-50.19	-13	-37.19
3	7014	49.46	-95.26	-45.80	-13	-32.80
4	8767.5	59.29	-95.26	-35.97	-13	-22.97

Antenna Polarity & Test Distance: Vertical at 3 M

No.	Freq. (MHz)	Reading (dB μ V/m)	Correction Factor (dB)	EIRP (dBm)	Limit (dBm)	Margin (dB)
1	3507	38.17	-95.26	-57.09	-13	-44.09
2	5260.5	44.97	-95.26	-50.29	-13	-37.29
3	7014	58.48	-95.26	-36.78	-13	-23.78
4	8767.5	63.12	-95.26	-32.14	-13	-19.14

Remarks:

1. Follow ANSI 63.26 section 5.2.7 d), EIRP Value (dBm) = E (dB μ V/m) - Correction Factor @ 3m.
2. Correction Factor (dB) = 20log(D) - 104.8; where D is the measurement distance @ 3m.

LTE Band 4: 5MHz

Mode	TX channel 19975	Frequency Range	Above 1000 MHz
------	------------------	-----------------	----------------

Antenna Polarity & Test Distance: Horizontal at 3 M

No.	Freq. (MHz)	Reading (dB μ V/m)	Correction Factor (dB)	EIRP (dBm)	Limit (dBm)	Margin (dB)
1	3425	38.49	-95.26	-56.77	-13	-43.77
2	5137.5	43.21	-95.26	-52.05	-13	-39.05
3	6850	49.32	-95.26	-45.94	-13	-32.94
4	8562.5	61.84	-95.26	-33.42	-13	-20.42

Antenna Polarity & Test Distance: Vertical at 3 M

No.	Freq. (MHz)	Reading (dB μ V/m)	Correction Factor (dB)	EIRP (dBm)	Limit (dBm)	Margin (dB)
1	3425	37.45	-95.26	-57.81	-13	-44.81
2	5137.5	45.3	-95.26	-49.96	-13	-36.96
3	6850	55.01	-95.26	-40.25	-13	-27.25
4	8562.5	62.6	-95.26	-32.66	-13	-19.66

Remarks:

1. Follow ANSI 63.26 section 5.2.7 d), EIRP Value (dBm) = E (dB μ V/m) - Correction Factor @ 3m.
2. Correction Factor (dB) = $20\log(D) - 104.8$; where D is the measurement distance @ 3m.

Mode	TX channel 20175	Frequency Range	Above 1000 MHz
------	------------------	-----------------	----------------

Antenna Polarity & Test Distance: Horizontal at 3 M

No.	Freq. (MHz)	Reading (dB μ V/m)	Correction Factor (dB)	EIRP (dBm)	Limit (dBm)	Margin (dB)
1	3465	35.85	-95.26	-59.41	-13	-46.41
2	5197.5	43.31	-95.26	-51.95	-13	-38.95
3	6930	49.18	-95.26	-46.08	-13	-33.08
4	8662.5	61.75	-95.26	-33.51	-13	-20.51

Antenna Polarity & Test Distance: Vertical at 3 M

No.	Freq. (MHz)	Reading (dB μ V/m)	Correction Factor (dB)	EIRP (dBm)	Limit (dBm)	Margin (dB)
1	3465	37.52	-95.26	-57.74	-13	-44.74
2	5197.5	46.57	-95.26	-48.69	-13	-35.69
3	6930	53.82	-95.26	-41.44	-13	-28.44
4	8662.5	64.47	-95.26	-30.79	-13	-17.79

Remarks:

1. Follow ANSI 63.26 section 5.2.7 d), EIRP Value (dBm) = E (dB μ V/m) - Correction Factor @ 3m.
2. Correction Factor (dB) = $20\log(D) - 104.8$; where D is the measurement distance @ 3m.

Mode	TX channel 20375	Frequency Range	Above 1000 MHz
------	------------------	-----------------	----------------

Antenna Polarity & Test Distance: Horizontal at 3 M

No.	Freq. (MHz)	Reading (dB μ V/m)	Correction Factor (dB)	EIRP (dBm)	Limit (dBm)	Margin (dB)
1	3505	35.75	-95.26	-59.51	-13	-46.51
2	5257.5	43.53	-95.26	-51.73	-13	-38.73
3	7010	50.99	-95.26	-44.27	-13	-31.27
4	8762.5	59.41	-95.26	-35.85	-13	-22.85

Antenna Polarity & Test Distance: Vertical at 3 M

No.	Freq. (MHz)	Reading (dB μ V/m)	Correction Factor (dB)	EIRP (dBm)	Limit (dBm)	Margin (dB)
1	3505	37.53	-95.26	-57.73	-13	-44.73
2	5257.5	47.24	-95.26	-48.02	-13	-35.02
3	7010	55.59	-95.26	-39.67	-13	-26.67
4	8762.5	63.18	-95.26	-32.08	-13	-19.08

Remarks:

1. Follow ANSI 63.26 section 5.2.7 d), EIRP Value (dBm) = E (dB μ V/m) - Correction Factor @ 3m.
2. Correction Factor (dB) = 20log(D) - 104.8; where D is the measurement distance @ 3m.

LTE Band 4: 10MHz

Mode	TX channel 20000	Frequency Range	Above 1000 MHz
------	------------------	-----------------	----------------

Antenna Polarity & Test Distance: Horizontal at 3 M

No.	Freq. (MHz)	Reading (dB μ V/m)	Correction Factor (dB)	EIRP (dBm)	Limit (dBm)	Margin (dB)
1	3430	39.59	-95.26	-55.67	-13	-42.67
2	5145	43.24	-95.26	-52.02	-13	-39.02
3	6860	49.31	-95.26	-45.95	-13	-32.95
4	8575	61.8	-95.26	-33.46	-13	-20.46

Antenna Polarity & Test Distance: Vertical at 3 M

No.	Freq. (MHz)	Reading (dB μ V/m)	Correction Factor (dB)	EIRP (dBm)	Limit (dBm)	Margin (dB)
1	3430	42.85	-95.26	-52.41	-13	-39.41
2	5145	45.6	-95.26	-49.66	-13	-36.66
3	6860	54.38	-95.26	-40.88	-13	-27.88
4	8575	63.69	-95.26	-31.57	-13	-18.57

Remarks:

1. Follow ANSI 63.26 section 5.2.7 d), EIRP Value (dBm) = E (dB μ V/m) - Correction Factor @ 3m.
2. Correction Factor (dB) = $20\log(D) - 104.8$; where D is the measurement distance @ 3m.

Mode	TX channel 20175	Frequency Range	Above 1000 MHz
------	------------------	-----------------	----------------

Antenna Polarity & Test Distance: Horizontal at 3 M

No.	Freq. (MHz)	Reading (dB μ V/m)	Correction Factor (dB)	EIRP (dBm)	Limit (dBm)	Margin (dB)
1	3465	41.96	-95.26	-53.30	-13	-40.30
2	5197.5	43.02	-95.26	-52.24	-13	-39.24
3	6930	49.8	-95.26	-45.46	-13	-32.46
4	8662.5	61.77	-95.26	-33.49	-13	-20.49

Antenna Polarity & Test Distance: Vertical at 3 M

No.	Freq. (MHz)	Reading (dB μ V/m)	Correction Factor (dB)	EIRP (dBm)	Limit (dBm)	Margin (dB)
1	3465	44.23	-95.26	-51.03	-13	-38.03
2	5197.5	48.82	-95.26	-46.44	-13	-33.44
3	6930	57.42	-95.26	-37.84	-13	-24.84
4	8662.5	65.31	-95.26	-29.95	-13	-16.95

Remarks:

1. Follow ANSI 63.26 section 5.2.7 d), EIRP Value (dBm) = E (dB μ V/m) - Correction Factor @ 3m.
2. Correction Factor (dB) = 20log(D) - 104.8; where D is the measurement distance @ 3m.

Mode	TX channel 20350	Frequency Range	Above 1000 MHz
------	------------------	-----------------	----------------

Antenna Polarity & Test Distance: Horizontal at 3 M

No.	Freq. (MHz)	Reading (dB μ V/m)	Correction Factor (dB)	EIRP (dBm)	Limit (dBm)	Margin (dB)
1	3500	40.07	-95.26	-55.19	-13	-42.19
2	5250	42.59	-95.26	-52.67	-13	-39.67
3	7000	50.09	-95.26	-45.17	-13	-32.17
4	8750	62.72	-95.26	-32.54	-13	-19.54

Antenna Polarity & Test Distance: Vertical at 3 M

No.	Freq. (MHz)	Reading (dB μ V/m)	Correction Factor (dB)	EIRP (dBm)	Limit (dBm)	Margin (dB)
1	3500	40.8	-95.26	-54.46	-13	-41.46
2	5250	46.47	-95.26	-48.79	-13	-35.79
3	7000	53.68	-95.26	-41.58	-13	-28.58
4	8750	65.09	-95.26	-30.17	-13	-17.17

Remarks:

1. Follow ANSI 63.26 section 5.2.7 d), EIRP Value (dBm) = E (dB μ V/m) - Correction Factor @ 3m.
2. Correction Factor (dB) = 20log(D) - 104.8; where D is the measurement distance @ 3m.

LTE Band 4: 15MHz

Mode	TX channel 20025	Frequency Range	Above 1000 MHz
------	------------------	-----------------	----------------

Antenna Polarity & Test Distance: Horizontal at 3 M

No.	Freq. (MHz)	Reading (dB μ V/m)	Correction Factor (dB)	EIRP (dBm)	Limit (dBm)	Margin (dB)
1	3435	40.14	-95.26	-55.12	-13	-42.12
2	5152.5	43.82	-95.26	-51.44	-13	-38.44
3	6870	49.57	-95.26	-45.69	-13	-32.69
4	8587.5	60.8	-95.26	-34.46	-13	-21.46

Antenna Polarity & Test Distance: Vertical at 3 M

No.	Freq. (MHz)	Reading (dB μ V/m)	Correction Factor (dB)	EIRP (dBm)	Limit (dBm)	Margin (dB)
1	3435	44.77	-95.26	-50.49	-13	-37.49
2	5152.5	48.99	-95.26	-46.27	-13	-33.27
3	6870	54.95	-95.26	-40.31	-13	-27.31
4	8587.5	62.57	-95.26	-32.69	-13	-19.69

Remarks:

1. Follow ANSI 63.26 section 5.2.7 d), EIRP Value (dBm) = E (dB μ V/m) - Correction Factor @ 3m.
2. Correction Factor (dB) = $20\log(D) - 104.8$; where D is the measurement distance @ 3m.

Mode	TX channel 20175	Frequency Range	Above 1000 MHz
------	------------------	-----------------	----------------

Antenna Polarity & Test Distance: Horizontal at 3 M

No.	Freq. (MHz)	Reading (dB μ V/m)	Correction Factor (dB)	EIRP (dBm)	Limit (dBm)	Margin (dB)
1	3465	40.8	-95.26	-54.46	-13	-41.46
2	5197.5	45.07	-95.26	-50.19	-13	-37.19
3	6930	52.59	-95.26	-42.67	-13	-29.67
4	8662.5	59.17	-95.26	-36.09	-13	-23.09

Antenna Polarity & Test Distance: Vertical at 3 M

No.	Freq. (MHz)	Reading (dB μ V/m)	Correction Factor (dB)	EIRP (dBm)	Limit (dBm)	Margin (dB)
1	3465	47.54	-95.26	-47.72	-13	-34.72
2	5197.5	48.22	-95.26	-47.04	-13	-34.04
3	6930	56.55	-95.26	-38.71	-13	-25.71
4	8662.5	62.94	-95.26	-32.32	-13	-19.32

Remarks:

1. Follow ANSI 63.26 section 5.2.7 d), EIRP Value (dBm) = E (dB μ V/m) - Correction Factor @ 3m.
2. Correction Factor (dB) = 20log(D) - 104.8; where D is the measurement distance @ 3m.

Mode	TX channel 20325	Frequency Range	Above 1000 MHz
------	------------------	-----------------	----------------

Antenna Polarity & Test Distance: Horizontal at 3 M

No.	Freq. (MHz)	Reading (dB μ V/m)	Correction Factor (dB)	EIRP (dBm)	Limit (dBm)	Margin (dB)
1	3495	43.28	-95.26	-51.98	-13	-38.98
2	5242.5	43.85	-95.26	-51.41	-13	-38.41
3	6990	48	-95.26	-47.26	-13	-34.26
4	8737.5	61.65	-95.26	-33.61	-13	-20.61

Antenna Polarity & Test Distance: Vertical at 3 M

No.	Freq. (MHz)	Reading (dB μ V/m)	Correction Factor (dB)	EIRP (dBm)	Limit (dBm)	Margin (dB)
1	3495	46.75	-95.26	-48.51	-13	-35.51
2	5242.5	46.94	-95.26	-48.32	-13	-35.32
3	6990	54.15	-95.26	-41.11	-13	-28.11
4	8737.5	66.11	-95.26	-29.15	-13	-16.15

Remarks:

1. Follow ANSI 63.26 section 5.2.7 d), EIRP Value (dBm) = E (dB μ V/m) - Correction Factor @ 3m.
2. Correction Factor (dB) = 20log(D) - 104.8; where D is the measurement distance @ 3m.

LTE Band 4: 20MHz

Mode	TX channel 20050	Frequency Range	Above 1000 MHz
------	------------------	-----------------	----------------

Antenna Polarity & Test Distance: Horizontal at 3 M

No.	Freq. (MHz)	Reading (dB μ V/m)	Correction Factor (dB)	EIRP (dBm)	Limit (dBm)	Margin (dB)
1	3440	39.86	-95.26	-55.40	-13	-42.40
2	5160	45.4	-95.26	-49.86	-13	-36.86
3	6880	52.08	-95.26	-43.18	-13	-30.18
4	8600	61.84	-95.26	-33.42	-13	-20.42

Antenna Polarity & Test Distance: Vertical at 3 M

No.	Freq. (MHz)	Reading (dB μ V/m)	Correction Factor (dB)	EIRP (dBm)	Limit (dBm)	Margin (dB)
1	3440	43.03	-95.26	-52.23	-13	-39.23
2	5160	47.28	-95.26	-47.98	-13	-34.98
3	6880	57.04	-95.26	-38.22	-13	-25.22
4	8600	65.02	-95.26	-30.24	-13	-17.24

Remarks:

1. Follow ANSI 63.26 section 5.2.7 d), EIRP Value (dBm) = E (dB μ V/m) - Correction Factor @ 3m.
2. Correction Factor (dB) = $20\log(D) - 104.8$; where D is the measurement distance @ 3m.

Mode	TX channel 20175	Frequency Range	Above 1000 MHz
------	------------------	-----------------	----------------

Antenna Polarity & Test Distance: Horizontal at 3 M

No.	Freq. (MHz)	Reading (dB μ V/m)	Correction Factor (dB)	EIRP (dBm)	Limit (dBm)	Margin (dB)
1	3465	36.88	-95.26	-58.38	-13	-45.38
2	5197.5	43.59	-95.26	-51.67	-13	-38.67
3	6930	51.96	-95.26	-43.30	-13	-30.30
4	8662.5	61.75	-95.26	-33.51	-13	-20.51

Antenna Polarity & Test Distance: Vertical at 3 M

No.	Freq. (MHz)	Reading (dB μ V/m)	Correction Factor (dB)	EIRP (dBm)	Limit (dBm)	Margin (dB)
1	3465	42.23	-95.26	-53.03	-13	-40.03
2	5197.5	44.63	-95.26	-50.63	-13	-37.63
3	6930	54.13	-95.26	-41.13	-13	-28.13
4	8662.5	64.62	-95.26	-30.64	-13	-17.64

Remarks:

1. Follow ANSI 63.26 section 5.2.7 d), EIRP Value (dBm) = E (dB μ V/m) - Correction Factor @ 3m.
2. Correction Factor (dB) = 20log(D) - 104.8; where D is the measurement distance @ 3m.

Mode	TX channel 20300	Frequency Range	Above 1000 MHz
------	------------------	-----------------	----------------

Antenna Polarity & Test Distance: Horizontal at 3 M

No.	Freq. (MHz)	Reading (dB μ V/m)	Correction Factor (dB)	EIRP (dBm)	Limit (dBm)	Margin (dB)
1	3490	39.27	-95.26	-55.99	-13	-42.99
2	5235	45.39	-95.26	-49.87	-13	-36.87
3	6980	52.7	-95.26	-42.56	-13	-29.56
4	8725	61.71	-95.26	-33.55	-13	-20.55

Antenna Polarity & Test Distance: Vertical at 3 M

No.	Freq. (MHz)	Reading (dB μ V/m)	Correction Factor (dB)	EIRP (dBm)	Limit (dBm)	Margin (dB)
1	3490	44.57	-95.26	-50.69	-13	-37.69
2	5235	47.52	-95.26	-47.74	-13	-34.74
3	6980	56.36	-95.26	-38.90	-13	-25.90
4	8725	65.68	-95.26	-29.58	-13	-16.58

Remarks:

1. Follow ANSI 63.26 section 5.2.7 d), EIRP Value (dBm) = E (dB μ V/m) - Correction Factor @ 3m.
2. Correction Factor (dB) = 20log(D) - 104.8; where D is the measurement distance @ 3m.

LTE Band 12: 1.4MHz

Mode	TX channel 23017	Frequency Range	Above 1000 MHz
------	------------------	-----------------	----------------

Antenna Polarity & Test Distance: Horizontal at 3 M

No.	Freq. (MHz)	Reading (dB μ V/m)	Correction Factor (dB)	EIRP (dBm)	Limit (dBm)	Margin (dB)
1	1399.4	36.26	-95.26	-59.00	-13	-46.00
2	2099.1	35.74	-95.26	-59.52	-13	-46.52
3	2798.8	48.48	-95.26	-46.78	-13	-33.78

Antenna Polarity & Test Distance: Vertical at 3 M

No.	Freq. (MHz)	Reading (dB μ V/m)	Correction Factor (dB)	EIRP (dBm)	Limit (dBm)	Margin (dB)
1	1399.4	41.87	-95.26	-53.39	-13	-40.39
2	2099.1	41.36	-95.26	-53.90	-13	-40.90
3	2798.8	51.39	-95.26	-43.87	-13	-30.87

Remarks:

1. Follow ANSI 63.26 section 5.2.7 d), EIRP Value (dBm) = E (dB μ V/m) - Correction Factor @ 3m.
2. Correction Factor (dB) = $20\log(D) - 104.8$; where D is the measurement distance @ 3m.

Mode	TX channel 23095	Frequency Range	Above 1000 MHz
------	------------------	-----------------	----------------

Antenna Polarity & Test Distance: Horizontal at 3 M

No.	Freq. (MHz)	Reading (dB μ V/m)	Correction Factor (dB)	EIRP (dBm)	Limit (dBm)	Margin (dB)
1	1415	38.29	-95.26	-56.97	-13	-43.97
2	2122.5	40.23	-95.26	-55.03	-13	-42.03
3	2830	48.83	-95.26	-46.43	-13	-33.43

Antenna Polarity & Test Distance: Vertical at 3 M

No.	Freq. (MHz)	Reading (dB μ V/m)	Correction Factor (dB)	EIRP (dBm)	Limit (dBm)	Margin (dB)
1	1415	36.71	-95.26	-58.55	-13	-45.55
2	2122.5	37.46	-95.26	-57.80	-13	-44.80
3	2830	50.69	-95.26	-44.57	-13	-31.57

Remarks:

1. Follow ANSI 63.26 section 5.2.7 d), EIRP Value (dBm) = E (dB μ V/m) - Correction Factor @ 3m.
2. Correction Factor (dB) = $20\log(D) - 104.8$; where D is the measurement distance @ 3m.

Mode	TX channel 23173	Frequency Range	Above 1000 MHz
------	------------------	-----------------	----------------

Antenna Polarity & Test Distance: Horizontal at 3 M

No.	Freq. (MHz)	Reading (dB μ V/m)	Correction Factor (dB)	EIRP (dBm)	Limit (dBm)	Margin (dB)
1	1430.6	39.82	-95.26	-55.44	-13	-42.44
2	2145.9	40.79	-95.26	-54.47	-13	-41.47
3	2861.2	48.72	-95.26	-46.54	-13	-33.54

Antenna Polarity & Test Distance: Vertical at 3 M

No.	Freq. (MHz)	Reading (dB μ V/m)	Correction Factor (dB)	EIRP (dBm)	Limit (dBm)	Margin (dB)
1	1430.6	41.26	-95.26	-54.00	-13	-41.00
2	2145.9	37.25	-95.26	-58.01	-13	-45.01
3	2861.2	51.54	-95.26	-43.72	-13	-30.72

Remarks:

1. Follow ANSI 63.26 section 5.2.7 d), EIRP Value (dBm) = E (dB μ V/m) - Correction Factor @ 3m.
2. Correction Factor (dB) = $20\log(D) - 104.8$; where D is the measurement distance @ 3m.

LTE Band 12: 3MHz

Mode	TX channel 23025	Frequency Range	Above 1000 MHz
------	------------------	-----------------	----------------

Antenna Polarity & Test Distance: Horizontal at 3 M

No.	Freq. (MHz)	Reading (dB μ V/m)	Correction Factor (dB)	EIRP (dBm)	Limit (dBm)	Margin (dB)
1	1401	37	-95.26	-58.26	-13	-45.26
2	2101.5	40.53	-95.26	-54.73	-13	-41.73
3	2802	47.45	-95.26	-47.81	-13	-34.81

Antenna Polarity & Test Distance: Vertical at 3 M

No.	Freq. (MHz)	Reading (dB μ V/m)	Correction Factor (dB)	EIRP (dBm)	Limit (dBm)	Margin (dB)
1	1401	38.14	-95.26	-57.12	-13	-44.12
2	2101.5	42.38	-95.26	-52.88	-13	-39.88
3	2802	49.23	-95.26	-46.03	-13	-33.03

Remarks:

1. Follow ANSI 63.26 section 5.2.7 d), EIRP Value (dBm) = E (dB μ V/m) - Correction Factor @ 3m.
2. Correction Factor (dB) = $20\log(D) - 104.8$; where D is the measurement distance @ 3m.

Mode	TX channel 23095	Frequency Range	Above 1000 MHz
------	------------------	-----------------	----------------

Antenna Polarity & Test Distance: Horizontal at 3 M

No.	Freq. (MHz)	Reading (dB μ V/m)	Correction Factor (dB)	EIRP (dBm)	Limit (dBm)	Margin (dB)
1	1415	39.35	-95.26	-55.91	-13	-42.91
2	2122.5	39.6	-95.26	-55.66	-13	-42.66
3	2830	47.4	-95.26	-47.86	-13	-34.86

Antenna Polarity & Test Distance: Vertical at 3 M

No.	Freq. (MHz)	Reading (dB μ V/m)	Correction Factor (dB)	EIRP (dBm)	Limit (dBm)	Margin (dB)
1	1415	43.47	-95.26	-51.79	-13	-38.79
2	2122.5	42.92	-95.26	-52.34	-13	-39.34
3	2830	48.06	-95.26	-47.20	-13	-34.20

Remarks:

1. Follow ANSI 63.26 section 5.2.7 d), EIRP Value (dBm) = E (dB μ V/m) - Correction Factor @ 3m.
2. Correction Factor (dB) = $20\log(D) - 104.8$; where D is the measurement distance @ 3m.

Mode	TX channel 23165	Frequency Range	Above 1000 MHz
------	------------------	-----------------	----------------

Antenna Polarity & Test Distance: Horizontal at 3 M

No.	Freq. (MHz)	Reading (dB μ V/m)	Correction Factor (dB)	EIRP (dBm)	Limit (dBm)	Margin (dB)
1	1429	39.38	-95.26	-55.88	-13	-42.88
2	2143.5	40.02	-95.26	-55.24	-13	-42.24
3	2858	45.5	-95.26	-49.76	-13	-36.76

Antenna Polarity & Test Distance: Vertical at 3 M

No.	Freq. (MHz)	Reading (dB μ V/m)	Correction Factor (dB)	EIRP (dBm)	Limit (dBm)	Margin (dB)
1	1429	42.45	-95.26	-52.81	-13	-39.81
2	2143.5	42.72	-95.26	-52.54	-13	-39.54
3	2858	46.32	-95.26	-48.94	-13	-35.94

Remarks:

1. Follow ANSI 63.26 section 5.2.7 d), EIRP Value (dBm) = E (dB μ V/m) - Correction Factor @ 3m.
2. Correction Factor (dB) = $20\log(D) - 104.8$; where D is the measurement distance @ 3m.

LTE Band 12: 5MHz

Mode	TX channel 23035	Frequency Range	Above 1000 MHz
------	------------------	-----------------	----------------

Antenna Polarity & Test Distance: Horizontal at 3 M

No.	Freq. (MHz)	Reading (dB μ V/m)	Correction Factor (dB)	EIRP (dBm)	Limit (dBm)	Margin (dB)
1	1403	41.54	-95.26	-53.72	-13	-40.72
2	2104.5	36.79	-95.26	-58.47	-13	-45.47
3	2806	46.38	-95.26	-48.88	-13	-35.88

Antenna Polarity & Test Distance: Vertical at 3 M

No.	Freq. (MHz)	Reading (dB μ V/m)	Correction Factor (dB)	EIRP (dBm)	Limit (dBm)	Margin (dB)
1	1403	43.46	-95.26	-51.80	-13	-38.80
2	2104.5	41.29	-95.26	-53.97	-13	-40.97
3	2806	48.22	-95.26	-47.04	-13	-34.04

Remarks:

1. Follow ANSI 63.26 section 5.2.7 d), EIRP Value (dBm) = E (dB μ V/m) - Correction Factor @ 3m.
2. Correction Factor (dB) = $20\log(D) - 104.8$; where D is the measurement distance @ 3m.

Mode	TX channel 23095	Frequency Range	Above 1000 MHz
------	------------------	-----------------	----------------

Antenna Polarity & Test Distance: Horizontal at 3 M

No.	Freq. (MHz)	Reading (dB μ V/m)	Correction Factor (dB)	EIRP (dBm)	Limit (dBm)	Margin (dB)
1	1415	36.59	-95.26	-58.67	-13	-45.67
2	2122.5	35.84	-95.26	-59.42	-13	-46.42
3	2830	43.54	-95.26	-51.72	-13	-38.72

Antenna Polarity & Test Distance: Vertical at 3 M

No.	Freq. (MHz)	Reading (dB μ V/m)	Correction Factor (dB)	EIRP (dBm)	Limit (dBm)	Margin (dB)
1	1415	38.88	-95.26	-56.38	-13	-43.38
2	2122.5	39.74	-95.26	-55.52	-13	-42.52
3	2830	46.55	-95.26	-48.71	-13	-35.71

Remarks:

1. Follow ANSI 63.26 section 5.2.7 d), EIRP Value (dBm) = E (dB μ V/m) - Correction Factor @ 3m.
2. Correction Factor (dB) = $20\log(D) - 104.8$; where D is the measurement distance @ 3m.

Mode	TX channel 23155	Frequency Range	Above 1000 MHz
------	------------------	-----------------	----------------

Antenna Polarity & Test Distance: Horizontal at 3 M

No.	Freq. (MHz)	Reading (dB μ V/m)	Correction Factor (dB)	EIRP (dBm)	Limit (dBm)	Margin (dB)
1	1427	38.32	-95.26	-56.94	-13	-43.94
2	2140.5	41.18	-95.26	-54.08	-13	-41.08
3	2854	43.43	-95.26	-51.83	-13	-38.83

Antenna Polarity & Test Distance: Vertical at 3 M

No.	Freq. (MHz)	Reading (dB μ V/m)	Correction Factor (dB)	EIRP (dBm)	Limit (dBm)	Margin (dB)
1	1427	40.32	-95.26	-54.94	-13	-41.94
2	2140.5	43.25	-95.26	-52.01	-13	-39.01
3	2854	46.04	-95.26	-49.22	-13	-36.22

Remarks:

1. Follow ANSI 63.26 section 5.2.7 d), EIRP Value (dBm) = E (dB μ V/m) - Correction Factor @ 3m.
2. Correction Factor (dB) = 20log(D) - 104.8; where D is the measurement distance @ 3m.

LTE Band 12: 10MHz

Mode	TX channel 23060	Frequency Range	Above 1000 MHz
------	------------------	-----------------	----------------

Antenna Polarity & Test Distance: Horizontal at 3 M

No.	Freq. (MHz)	Reading (dB μ V/m)	Correction Factor (dB)	EIRP (dBm)	Limit (dBm)	Margin (dB)
1	1408	39.67	-95.26	-55.59	-13	-42.59
2	2112	37.41	-95.26	-57.85	-13	-44.85
3	2816	45.2	-95.26	-50.06	-13	-37.06

Antenna Polarity & Test Distance: Vertical at 3 M

No.	Freq. (MHz)	Reading (dB μ V/m)	Correction Factor (dB)	EIRP (dBm)	Limit (dBm)	Margin (dB)
1	1408	41.97	-95.26	-53.29	-13	-40.29
2	2112	38.66	-95.26	-56.60	-13	-43.60
3	2816	47.3	-95.26	-47.96	-13	-34.96

Remarks:

1. Follow ANSI 63.26 section 5.2.7 d), EIRP Value (dBm) = E (dB μ V/m) - Correction Factor @ 3m.
2. Correction Factor (dB) = $20\log(D) - 104.8$; where D is the measurement distance @ 3m.

Mode	TX channel 23095	Frequency Range	Above 1000 MHz
------	------------------	-----------------	----------------

Antenna Polarity & Test Distance: Horizontal at 3 M

No.	Freq. (MHz)	Reading (dB μ V/m)	Correction Factor (dB)	EIRP (dBm)	Limit (dBm)	Margin (dB)
1	1415	37.26	-95.26	-58.00	-13	-45.00
2	2122.5	37.31	-95.26	-57.95	-13	-44.95
3	2830	43.58	-95.26	-51.68	-13	-38.68

Antenna Polarity & Test Distance: Vertical at 3 M

No.	Freq. (MHz)	Reading (dB μ V/m)	Correction Factor (dB)	EIRP (dBm)	Limit (dBm)	Margin (dB)
1	1415	39.6	-95.26	-55.66	-13	-42.66
2	2122.5	41.87	-95.26	-53.39	-13	-40.39
3	2830	45.81	-95.26	-49.45	-13	-36.45

Remarks:

1. Follow ANSI 63.26 section 5.2.7 d), EIRP Value (dBm) = E (dB μ V/m) - Correction Factor @ 3m.
2. Correction Factor (dB) = $20\log(D) - 104.8$; where D is the measurement distance @ 3m.

Mode	TX channel 23130	Frequency Range	Above 1000 MHz
------	------------------	-----------------	----------------

Antenna Polarity & Test Distance: Horizontal at 3 M

No.	Freq. (MHz)	Reading (dB μ V/m)	Correction Factor (dB)	EIRP (dBm)	Limit (dBm)	Margin (dB)
1	1422	39.71	-95.26	-55.55	-13	-42.55
2	2133	40.81	-95.26	-54.45	-13	-41.45
3	2844	43.1	-95.26	-52.16	-13	-39.16

Antenna Polarity & Test Distance: Vertical at 3 M

No.	Freq. (MHz)	Reading (dB μ V/m)	Correction Factor (dB)	EIRP (dBm)	Limit (dBm)	Margin (dB)
1	1422	41.11	-95.26	-54.15	-13	-41.15
2	2133	42.24	-95.26	-53.02	-13	-40.02
3	2844	46.19	-95.26	-49.07	-13	-36.07

Remarks:

1. Follow ANSI 63.26 section 5.2.7 d), EIRP Value (dBm) = E (dB μ V/m) - Correction Factor @ 3m.
2. Correction Factor (dB) = $20\log(D) - 104.8$; where D is the measurement distance @ 3m.

LTE Band 13: 5MHz

Mode	TX channel 23205	Frequency Range	Above 1000 MHz
------	------------------	-----------------	----------------

Antenna Polarity & Test Distance: Horizontal at 3 M

No.	Freq. (MHz)	Reading (dB μ V/m)	Correction Factor (dB)	EIRP (dBm)	Limit (dBm)	Margin (dB)
1	1559	35.66	-95.26	-59.60	-40	-19.60
2	2338.5	38.15	-95.26	-57.11	-13	-44.11
3	3118	49.45	-95.26	-45.81	-13	-32.81

Antenna Polarity & Test Distance: Vertical at 3 M

No.	Freq. (MHz)	Reading (dB μ V/m)	Correction Factor (dB)	EIRP (dBm)	Limit (dBm)	Margin (dB)
1	1559	37.12	-95.26	-58.14	-40	-18.14
2	2338.5	40.85	-95.26	-54.41	-13	-41.41
3	3118	50.42	-95.26	-44.84	-13	-31.84

Remarks:

1. Follow ANSI 63.26 section 5.2.7 d), EIRP Value (dBm) = E (dB μ V/m) - Correction Factor @ 3m.
2. Correction Factor (dB) = $20\log(D) - 104.8$; where D is the measurement distance @ 3m.

Mode	TX channel 23230	Frequency Range	Above 1000 MHz
------	------------------	-----------------	----------------

Antenna Polarity & Test Distance: Horizontal at 3 M

No.	Freq. (MHz)	Reading (dB μ V/m)	Correction Factor (dB)	EIRP (dBm)	Limit (dBm)	Margin (dB)
1	1564	37.91	-95.26	-57.35	-40	-17.35
2	2346	35.85	-95.26	-59.41	-13	-46.41
3	3128	45.96	-95.26	-49.30	-13	-36.30

Antenna Polarity & Test Distance: Vertical at 3 M

No.	Freq. (MHz)	Reading (dB μ V/m)	Correction Factor (dB)	EIRP (dBm)	Limit (dBm)	Margin (dB)
1	1564	40.26	-95.26	-55.00	-40	-15.00
2	2346	37.85	-95.26	-57.41	-13	-44.41
3	3128	47.86	-95.26	-47.40	-13	-34.40

Remarks:

1. Follow ANSI 63.26 section 5.2.7 d), EIRP Value (dBm) = E (dB μ V/m) - Correction Factor @ 3m.
2. Correction Factor (dB) = 20log(D) - 104.8; where D is the measurement distance @ 3m.

Mode	TX channel 23255	Frequency Range	Above 1000 MHz
------	------------------	-----------------	----------------

Antenna Polarity & Test Distance: Horizontal at 3 M

No.	Freq. (MHz)	Reading (dB μ V/m)	Correction Factor (dB)	EIRP (dBm)	Limit (dBm)	Margin (dB)
1	1569	36.31	-95.26	-58.95	-40	-18.95
2	2353.5	36.35	-95.26	-58.91	-13	-45.91
3	3138	47.41	-95.26	-47.85	-13	-34.85

Antenna Polarity & Test Distance: Vertical at 3 M

No.	Freq. (MHz)	Reading (dB μ V/m)	Correction Factor (dB)	EIRP (dBm)	Limit (dBm)	Margin (dB)
1	1569	40.02	-95.26	-55.24	-40	-15.24
2	2353.5	38.22	-95.26	-57.04	-13	-44.04
3	3138	48.28	-95.26	-46.98	-13	-33.98

Remarks:

1. Follow ANSI 63.26 section 5.2.7 d), EIRP Value (dBm) = E (dB μ V/m) - Correction Factor @ 3m.
2. Correction Factor (dB) = $20\log(D) - 104.8$; where D is the measurement distance @ 3m.

LTE Band 13: 10MHz

Mode	TX channel 23230	Frequency Range	Above 1000 MHz
------	------------------	-----------------	----------------

Antenna Polarity & Test Distance: Horizontal at 3 M

No.	Freq. (MHz)	Reading (dB μ V/m)	Correction Factor (dB)	EIRP (dBm)	Limit (dBm)	Margin (dB)
1	1564	38.18	-95.26	-57.08	-40	-17.08
2	2346	37.24	-95.26	-58.02	-13	-45.02
3	3128	47.74	-95.26	-47.52	-13	-34.52

Antenna Polarity & Test Distance: Vertical at 3 M

No.	Freq. (MHz)	Reading (dB μ V/m)	Correction Factor (dB)	EIRP (dBm)	Limit (dBm)	Margin (dB)
1	1564	40.82	-95.26	-54.44	-40	-14.44
2	2346	38.24	-95.26	-57.02	-13	-44.02
3	3128	48.56	-95.26	-46.70	-13	-33.70

Remarks:

1. Follow ANSI 63.26 section 5.2.7 d), EIRP Value (dBm) = E (dB μ V/m) - Correction Factor @ 3m.
2. Correction Factor (dB) = $20\log(D) - 104.8$; where D is the measurement distance @ 3m.

5 Pictures of Test Arrangements

Please refer to the attached file (Test Setup Photo).

Appendix – Information of the Testing Laboratories

We, Bureau Veritas Consumer Products Services (H.K.) Ltd., Taoyuan Branch, were founded in 1988 to provide our best service in EMC, Radio, Telecom and Safety consultation. Our laboratories are accredited and approved according to ISO/IEC 17025.

If you have any comments, please feel free to contact us at the following:

Lin Kou EMC/RF Lab

Tel: 886-2-26052180

Fax: 886-2-26051924

Hsin Chu EMC/RF Lab/Telecom Lab

Tel: 886-3-6668565

Fax: 886-3-6668323

Hwa Ya EMC/RF/Safety

Tel: 886-3-3183232

Fax: 886-3-3270892

Email: service.adt@tw.bureauveritas.com

Web Site: www.bureauveritas-adt.com

The address and road map of all our labs can be found in our web site also.

--- END ---