

## User manual

**Project Name:** M14Q2F

---

**Author:** Wistron NeWeb Corporation

---

**Revision:** 1.0

---

**Revision Date:** 2016/06/23

## Contact Information

Sale and Technical Support	SupportIoT.MBA@wnc.com.tw
Website	www.wnc.com.tw

## Revision History

Rev. #	Author	Summary of Changes	Date
1.0	WNC MBU	Draft release	2016/6/23

**© Wistron NeWeb Corporation**

THIS DOCUMENT AND THE INFORMATION CONTAINED HEREIN IS PROPRIETARY AND IS THE EXCLUSIVE PROPERTY OF WNC AND SHALL NOT BE DISTRIBUTED, REPRODUCED, OR DISCLOSED IN WHOLE OR IN PART WITHOUT PRIOR WRITTEN PERMISSION FROM WNC.

**LIMITATION OF LIABILITY**

THIS DOCUMENT AND THE INFORMATION CONTAINED HEREIN IS PURELY FOR DESIGN REFERENCE AND SUBJECT TO REVISION BY WNC AT ANY TIME. NOTHING IN THIS DOCUMENT SHALL BE CONSTRUED AS GRANTING ANY WARRANTY OR RIGHT TO USE THE MATERIAL CONTAINED HEREIN WITHOUT WNC'S PRIOR EXPRESS WRITTEN CONSENT. WNC SHALL NOT BE LIABLE FOR ANY USE, APPLICATION OR DEVELOPMENT DERIVED FROM THE MATERIAL WITHOUT SUCH PRIOR EXPRESS WRITTEN CONSENT.

**FCC Regulations:**

This device complies with part 15 of the FCC Rules. Operation is subject to the following two conditions: (1) This device may not cause harmful interference, and (2) This device must accept any interference received, including interference that may cause undesired operation.

This device has been tested and found to comply with the limits for a Class B digital device, pursuant to Part 15 of the FCC Rules. These limits are designed to provide reasonable protection against harmful interference in a residential installation. This equipment generates, uses and can radiated radio frequency energy and, if not installed and used in accordance with the instructions, may cause harmful interference to radio communications. However, there is no guarantee that interference will not occur in a particular installation. If this equipment does cause harmful interference to radio or television reception, which can be determined by turning the equipment off and on, the user is encouraged to try to correct the interference by one or more of the following measures:

- Reorient or relocate the receiving antenna.
- Increase the separation between the equipment and receiver.
- Connect the equipment into an outlet on a circuit different from that to which the receiver is connected.
- Consult the dealer or an experienced radio/TV technician for help.

Caution: Changes or modifications not expressly approved by the party responsible for compliance could void the user's authority to operate the equipment.

## RF Exposure Information

**This device is intended only for OEM integrators under the following conditions:**

- (1) The antenna must be installed such that 20 cm is maintained between the antenna and users,
- (2) The transmitter module may not be co-located with any other transmitter or antenna.
- (3) To comply with FCC regulations limiting both maximum RF output power and human exposure to RF radiation, the maximum antenna gain including cable loss in a mobile exposure condition must not exceed:

**Standalone Condition:**

- 8.0 dBi in 700 MHz Band
- 8.0 dBi in 850 MHz Band
- 5.0 dBi in 1700 MHz Band
- 7.5 dBi in 1900 MHz Band

**Assuming collocated with a WLAN transmitter with maximum 27 dBm average EIRP power**

- 7.0 dBi in 700 MHz Band
- 5.0 dBi in 850 MHz Band
- 5.0 dBi in 1700 MHz Band
- 7.5 dBi in 1900 MHz Band

Remark: This assumption is not valid if the output power of the collocated WLAN transmitter is higher than 27 dBm.

### IMPORTANT NOTE:

This module is intended for OEM integrator. The OEM integrator is still responsible for the FCC compliance requirement of the end product, which integrates this module. 20cm minimum distance has to be able to be maintained between the antenna and the users for the host this module is integrated into. Under such configuration, the FCC radiation exposure limits set forth for an population/uncontrolled environment can be satisfied.

Any changes or modifications not expressly approved by the manufacturer could void the user's authority to operate this equipment.

### USERS MANUAL OF THE END PRODUCT:

In the users manual of the end product, the end user has to be informed to keep at least 20cm separation with the antenna while this end product is installed and operated. The end user has to be informed that the FCC radio-frequency exposure guidelines for an uncontrolled environment can be satisfied. The end user has to also be informed that any changes or modifications not expressly approved by the manufacturer could void the user's authority to operate this equipment. If the size of the end product is smaller than 8x10cm, then additional FCC part 15.19 statement is required

to be available in the users manual: This device complies with Part 15 of FCC rules. Operation is subject to the following two conditions: (1) this device may not cause harmful interference and (2) this device must accept any interference received, including interference that may cause undesired operation.

# Contents

<b>Contact Information</b> .....	<b>2</b>
<b>Revision History</b> .....	<b>2</b>
<b>Contents</b> .....	<b>6</b>
<b>1. Introduction</b> .....	<b>8</b>
1.1. Features .....	8
<b>2. Electrical Specifications</b> .....	<b>9</b>
2.1. Host interface pin assignments.....	9
2.1.1. LGA Pad Diagram .....	9
2.1.2. Pin Assignments.....	10
2.2. Power supply .....	12
2.3. USB interface.....	14
2.4. SGMII interface .....	15
2.5. HSIC interface .....	16
2.6. SIM interface.....	17
2.7. Control interface (wakeup) .....	17
2.8. Digital interface.....	18
2.8.1. JTAG Interface.....	18
2.8.2. SPI Master Interface.....	18
2.8.3. PCM Interface.....	19
2.8.4. I2S Interface.....	19
2.8.5. I2C Interface .....	20
2.8.6. UART Interface.....	20
2.8.7. ADC Interface .....	21
<b>3. RF Specifications</b> .....	<b>22</b>
3.1. RF connections .....	22

- 3.2. RF Layout guidance .....22
- 3.3. Antenna Guidance .....24
- 3.4. Interference and sensitivity .....24
- 3.5. Radiated sensitivity measurement .....25
- 3.6. Supported frequencies .....25
- 4. Software Interface ..... 27**
  - 4.1. Support tools.....27
  - 4.2. USB interface.....27
- 5. Mechanical and Environmental Certifications ..... 28**
  - 5.1. PCBA Form Factor.....28
  - 5.2. Labeling .....31
- 6. Regulatory Compliance and Certification..... 32**
  - 6.1. Certification testing .....32
- 7. Safety Recommendation ..... 33**

# 1. Introduction

The M14Q2F is a Cat. 1 LTE modem which incorporates an application CPU subsystem and a host of peripheral interfaces and functions uniquely designed to address the power/performance/cost requirements of IoT and M2M applications. The chip is based on Qualcomm's MDM architecture which offers OFDMA-related software based signal processing capabilities that significantly exceed traditional communications ARM cores.

The CPU subsystem features a high performance Cortex A7 microprocessor running a Linux OS with a variety of host interfaces including USB 2.0, SGMII, SPI, UART, PCM, I2C, HSIC, USIM & SDC. The module supports integrated VoLTE functionality, with a variety of narrow- and wide-band CODECs and full IMS signaling.

## 1.1. Features

- 3GPP category support: LTE Cat. 1 with (10Mbps downlink, 5Mbps uplink)
- Supports LTE B2/4/5/12
- Supports WCDMA B2/5
- Ultra-high-performance Cortex A7 microprocessor
- Modem subsystem (MSS)
- Integrated support for VoLTE
- Resource and power management (RPM) subsystem
- Optimized for M2M and IoT markets
- Interfaces
  - HS USB 2.0 with integrated PHY
  - SGMII interface
  - HSIC interface
  - Dual UART interfaces (4 bit and 2 bit) for data transfer and diagnostic tools
  - SDC1: First SPI interface
  - I2C: Second SPI interface
  - USIM interface
  - GPIOs
  - ADC
  - PCM/I2S
  - JTAG interface



## 2. Electrical Specifications

### 2.1. Host interface pin assignments

#### 2.1.1. LGA Pad Diagram

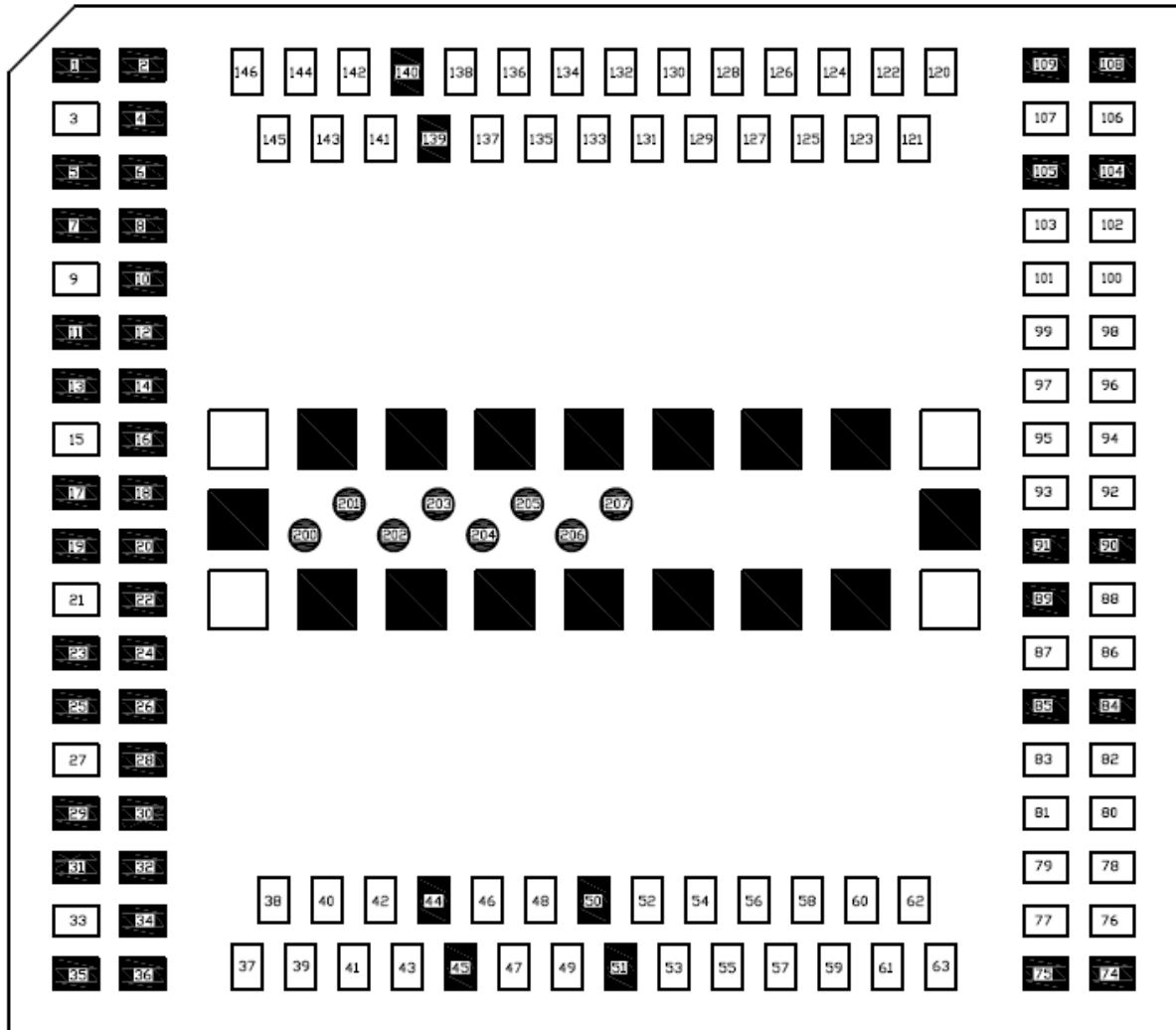

Figure 1. LGA pad diagram (top view)

**2.1.2. Pin Assignments**

Table 1. Pin interface family

Interface Family		Signal	Description	I/O
RF Interfaces		ANT1_DRX	Diversity antenna	I
		ANT_GNSS	Reserved for GNSS receiver	I
		ANT0_TRX	Main Antenna	I/O
User Identity Module		VREG_L6_UIM1	Power source for UIM	O
		UIM1_DATA	Data in/out	I/O
		UIM1_CLK	Clock signal	O
		UIM1_RESET	Reset signal	O
		UIM1_DETECT	UIM Detect signal	I/O
Data Interfaces	USB 2.0	USB_HS_DP	USB Data Positive	I/O
		USB Detect	USB Detect	I
		USB_HS_DM	USB Data Negative	I/O
	HSIC	HSIC_USB_STROBE	HSIC USB Strobe	I/O
		HSIC_USB_DATA	HSIC USB Data	I/O
	SGMII	SGMII_RX_P	SGMII receive - plus	I
		SGMII_RX_M	SGMII receive - minus	I
		SGMII_TX_P	SGMII transmit - plus	O
		SGMII_TX_M	SGMII transmit - minus	O
		SGMII_MDIO	SGMII Management data	I/O
		SGMII_MDC	SGMII Management data clock	I/O
	UART1	UART1_CTS_N	Clear To Send for UART 1	I
		UART1_RFR_N	UART ready for frame	O
		UART1_RX	Receive for UART 1	I
		UART1_TX	Transmit for UART 1	O
	UART2	MDM_DBG_UART_RX	Receive for UART 2	I
		MDM_DBG_UART_TX	Transmit for UART 2	O
	I2C/2nd_SPI	I2C_SDA	Data in/out	I/O
		2nd_SPI_EN_1	2nd_SPI chip select	O
		I2C_SCL	Clock signal	O
		2nd_SPI_CLK	2nd_SPI serial clock	O
		NC	NC	
		SPI_MOSI	2nd_SPI master out slave in	O
		NC	NC	

	SDC1/1st_SPI	SPI_MISO	2nd_SPI master in slave out	I
		SDC1_DATA_3	SDC1_DATA_3	I/O
		1st_SPIM_MOSI	1st_SPI master out slave in	O
		SDC1_DATA_2	SDC1_DATA_2	I/O
		1st_SPIM_MISO	1st_SPI master in slave out	I
		SDC1_DATA_1	SDC1_DATA_1	I/O
		1st_SPIM_EN_1	1st_SPI chip select	O
		SDC1_DATA_0	SDC1_DATA_0	I/O
		1st_SPIM_CLK	1st_SPI serial clock	O
		SDC1_CMD	SDC1_CMD	I/O
		SDC1_CLK	SDC1_CLK	O
Module Control and State Interfaces		WWAN_STATE	Wireless WAN Radio State	O
		POWER_ON	Power On the module	I
		WAKEUP_OUT	Module wakes up host OR GPIO	O
		WAKEUP_IN	Host wakes up module OR GPIO.	I
		RESET	Reset the module	I
Power and Ground		VREF	Voltage Reference Output	O
		VCC	Main Power	I
		GND	GND	I
General Purpose		GPIO	Digital I/O	I/O
		ADC_CONVENTOR	ADC_CONVENTOR	I
AUDIO	PCM/I2S	PCM_DIN	PCM_DIN	IO
		AUX_BT_I2S_DATA0	AUX_BT_I2S_DATA0	IO
		PCM_DOUT	PCM_DOUT	IO
		AUX_BT_I2S_DATA1	AUX_BT_I2S_DATA1	IO
		PCM_CLK	PCM_CLK	O
		AUX_BT_I2S_SCK	AUX_BT_I2S_SCK	O
		PCM_SYNC	PCM_SYNC	O
		AUX_BT_I2S_WS	AUX_BT_I2S_WS	O
RFU	RFU	RFU	Reserved For Future Use	I
Debug	JTAG	MDM_JTAG_SRST_N	JTAG reset for debug	I
		MDM_JTAG_TCK	JTAG clock input	I
		MDM_JTAG_TDI	JTAG data input	I
		MDM_JTAG_TDO	JTAG data output	O
		MDM_JTAG_TMS	JTAG mode select input	I
		MDM_JTAG_TRST_N	JTAG reset	O

		MDM_PS_HOLD	PS_HOLD	I
	Force_USB_BOOT	Force_USB_BOOT_CONFIG	Force USB BOOT CONFIG	I

Table 2. Digital I/O characteristics

Parameter		Comments	Min	Max	Unit
V <sub>IH</sub>	High-level input voltage	CMOS/Schmitt	0.65 * V <sub>DD_Px</sub>	–	V
V <sub>IL</sub>	Low-level input voltage	CMOS/Schmitt	–	0.35 * V <sub>DD_Px</sub>	V
V <sub>OH</sub>	High-level output voltage	CMOS, at rated drive strength <sup>1</sup>	V <sub>DD_Px</sub> - 0.45		V
V <sub>OL</sub>	Low-level output voltage	CMOS, at rated drive strength <sup>1</sup>	–	0.45	V
R <sub>P</sub>	Pull resistance <sup>2</sup>	Pullup and pulldown	55	390	kΩ
R <sub>K</sub>	Keeper resistance <sup>2</sup>		30	150	kΩ
I <sub>IH</sub>	Input high leakage current <sup>3</sup>	No pulldown	–	1	μA
I <sub>IL</sub>	Input low leakage current <sup>4</sup>	No pullup	-1	–	μA
V <sub>SHYS</sub>	Schmitt hysteresis voltage		100	–	mV
C <sub>I/O</sub>	I/O capacitance		–	5	pF

Note: This is preliminary data for reference and will be updated according to the final version of the MDM9207 datasheet.

## 2.2. Power supply

LTE module power input is VCC. The internal power chipset will transfer VCC to other power level.

Table 3. Power supply specifications

Power	Pin Name	Pads	Description	Voltage Level (V)		
				Min.	Typ.	Max.
VCC	VCC1 to VCC6	Nos. 37 to 42	Main Power Supply	3.3	3.8	4.2

The M14Q2F includes an integrated power manager enabling single and direct voltage supply from the battery, reducing the overall bill of materials.

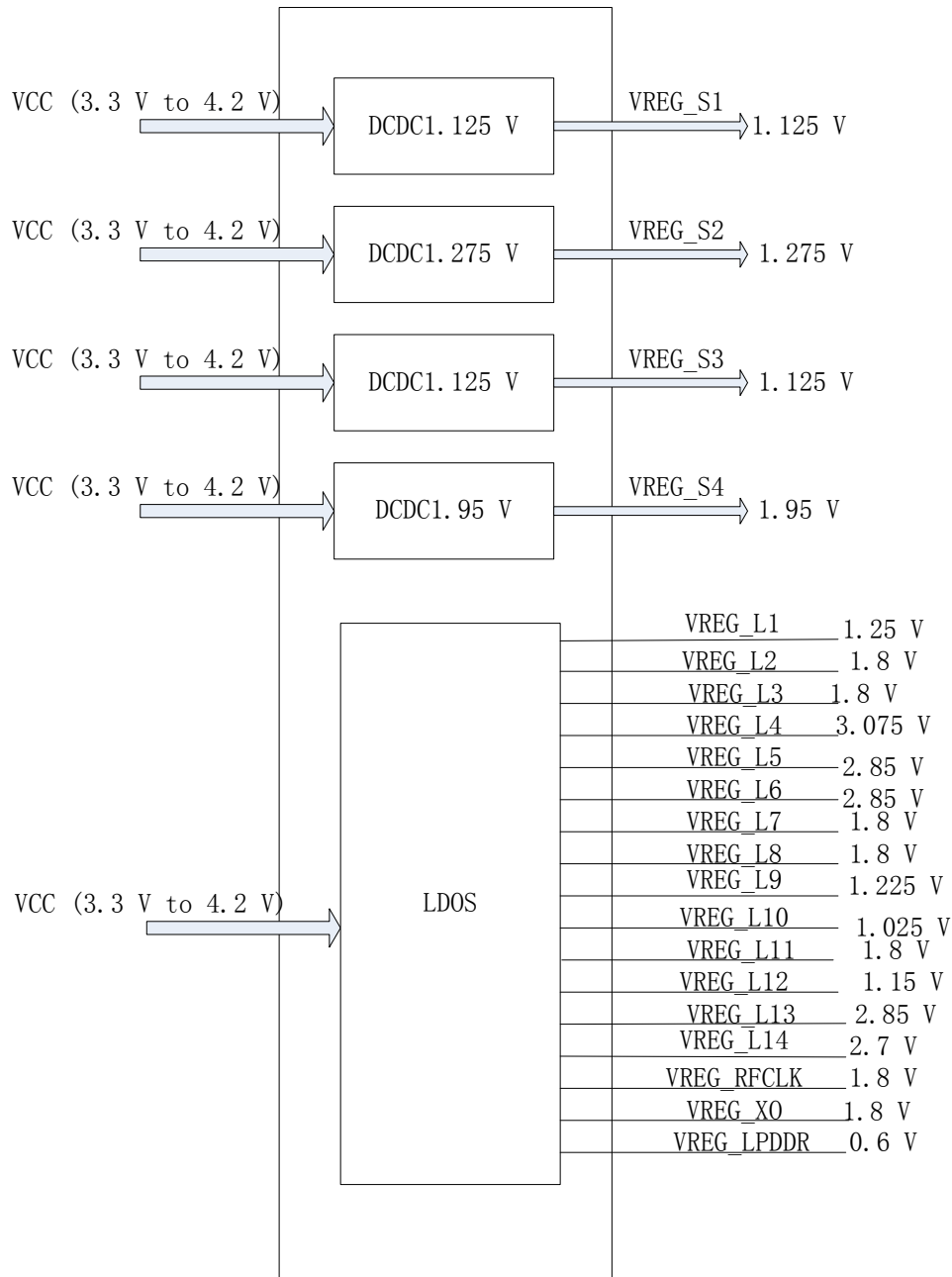

Figure 2. M14Q2F internal power path

**Layout Suggestion:** Each power trace should possess sufficient line width to withstand its respective current listed in the table below:

Net Name	Current Value
VCC(1–6) total	2A
UIM_VCC	150 mA
VREF	300 mA

## 2.3. USB interface

The M14Q2F module complies with USB 2.0 high-speed protocol. The USB input/output lines follow USB 2.0 specifications.

Table 4. Signals of the USB interface

Name	Description	Input/Output (Direction to module)	Voltage Level (V)		
			Min.	Typ.	Max.
D+	USB data positive (low-/full-speed)	Input High	2	3.3	3.6
		Input Low	0		0.8
		Output High	2.8	3.3	3.6
		Output Low			0.3
	USB data positive (high-speed)	Input High	0.3		0.44
		Input Low	0		0.01
		Output High	0.36	0.38	0.44
		Output Low	0		0.01
D-	USB data negative (low-/full-speed)	Input High	2	3.3	3.6
		Input Low	0		0.8
		Output High	2.8	3.3	3.6
		Output Low			0.3
	USB data negative (high-speed)	Input High	0.3		0.44
		Input Low	0		0.01
		Output High	0.36	0.38	0.44
		Output Low	0		0.01

The layout design of this circuit on the host board should comply with the USB 2.0 high-speed protocol.

### Layout suggestion:

- Differential impedance: 90 Ω
- Space to other signals should be at least 20 mils
- Intra-lane length difference should be less than 150 mils
- Maximum length for each trace:150 mm

Signals lengths on M14Q2F are tuned as below:

Function	Net	Length (mil)
USB	USB_Dp	545.54
	USB_Dn	503.04

## 2.4. SGMII interface

The M14Q2F includes integrated Ethernet MAC with SGMII interfaces with the following key features:

- IEEE 802.3 compliance
- Full duplex at 1 Gbps
- Half/full duplex for 10/100 Mbps
- Supports VLAN tagging
- Supports IEEE 1588, Precision Time Protocol (PTP)
- Can be used to connect to external Ethernet PHYs such as AR8033 or to an external switch

The following figures describe an example of the additional logic connection between the M14Q2F and the Ethernet chip.

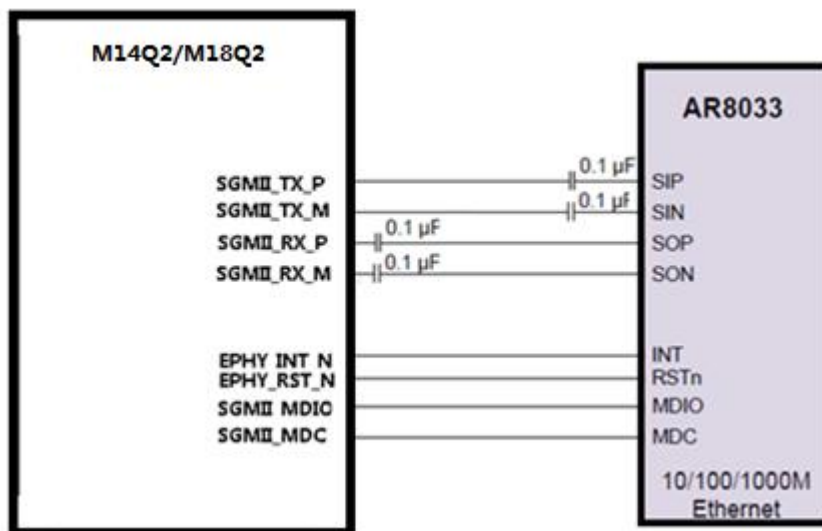

Figure 3. SGMII circuit example

### Layout suggestion:

- Differential impedance: 100 Ω
- Space to other signals: > 3x line width
- Lane-to-lane space: > 3x line width
- Intra-lane mismatch: < 0.7 mm

Signals lengths on the M14Q2F are tuned as below:

Function	Net	Length (mil)
SGMII	SGMII_TX_P	617.11
	SGMII_TX_M	642.13
	SGMII_RX_P_C+SGMII_RX_P	661.40
	SGMII_RX_M_C+SGMII_RX_M	675.06

## 2.5. HSIC interface

The M14Q2F includes a HSIC interface. This host interface can be connected to other application processor or interface-transfer chipset.

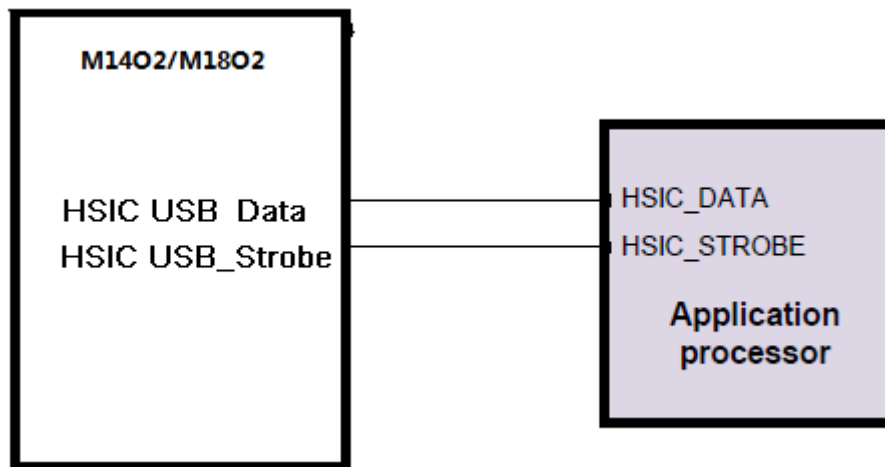

Figure 4. HSIC circuit example

### Layout suggestion:

- Single-end impedance: 50 Ω
- Intra-lane mismatch: < 2 mm
- Maximum trace length:100 mm

Signals lengths on the M14Q2F are tuned as below:

Function	Net	Length (mil)
HSIC	HSIC_STB	287.29
	HSIC_DATA	315.04



## 2.6. SIM interface

The M14Q2F includes a SIM controller, interface pins, and a dedicated LDO (3.0 V or 1.8 V).

The following figures describe the additional logic connection between the M14Q2F and the SIM card.

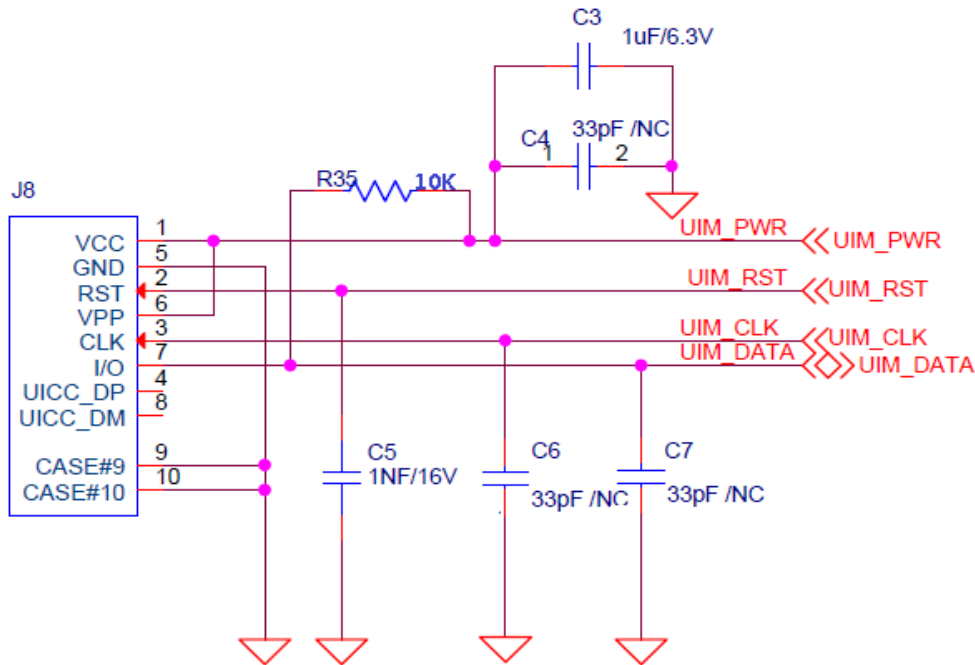

Figure 5. SIM card circuit (example)

## 2.7. Control interface (wake-up)

In applications where power consumption is a major factor in performance metrics (such as battery-operated sensors that are based on IOT/M2M modem solution and also include a third party host), it is necessary to define a simple interface that will allow both the modem and the host to be able to enter low power states whenever possible and the other side to wake it up once required.

For example, if the host has no data to transmit nor any other tasks, it may enter some low power state according to its own capabilities and configurations. If during that period the host is in a low power state and the modem suddenly receives data, it must wake-up the host.

A similar requirement exists from the other side. For example, if the modem is in a low power state and suddenly the host must transmit data, it must be able to wake-up the modem.

The interface consists of two signals: One is driven by the host and received by the modem; the other is driven by the modem and received by the host.

Each side can wake the other side by toggling wakeup signal high and allowing the other side to go to

sleep when not needed by toggling it low.

- “WAKEUP\_IN” (Host: Output, Modem: Input):  
 LOW: SoC does not require the MODEM (allowing it to sleep).  
 HIGH: SoC requires the MODEM or acknowledges it is ready following a wakeup request from the MODEM.
  
- “WAKEUP\_OUT” (Host: Input, Modem: Output):  
 LOW: The MODEM does not require the Host (allowing it to sleep)  
 HIGH: The MODEM requires the Host or acknowledges it is ready following a wakeup request from the SoC.

## 2.8. Digital interface

This section provides the required AC timing information relating to Module Digital Interfaces.

### 2.8.1. JTAG Interface

There is one JTAG interface for LGA module debugging.

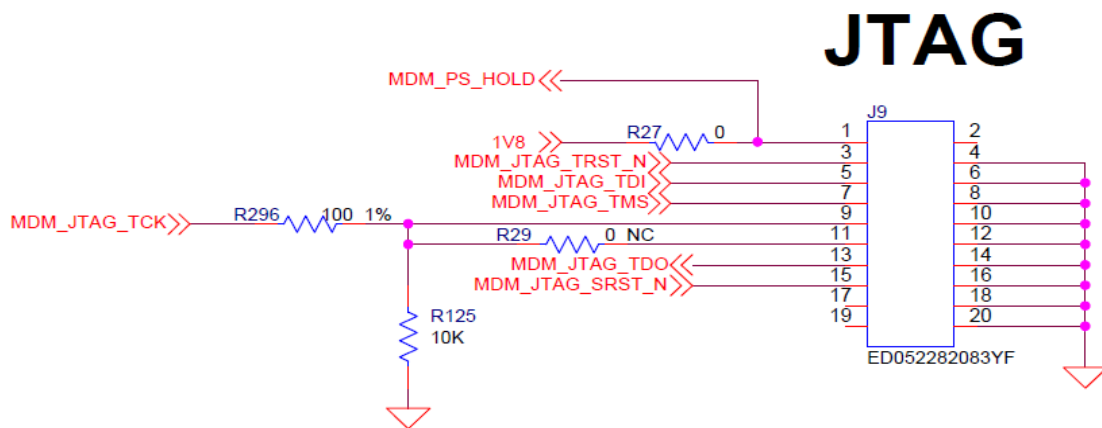

Figure 6. JTAG schematic (example)

### 2.8.2. SPI Master Interface

- SPIM\_CLK – Output clock
- SPIM\_CS – Output, chip-select
- SPIM\_MOSI – Output, data to slave
- SPIM\_MISO – Input, data from slave

**Timing**

Note: This part will be updated according to the final MDM9207 datasheet.

**2.8.3. PCM Interface**

The LGA module provides one PCM digital audio interface. The PCM data bus voltage level is 1.8 V.

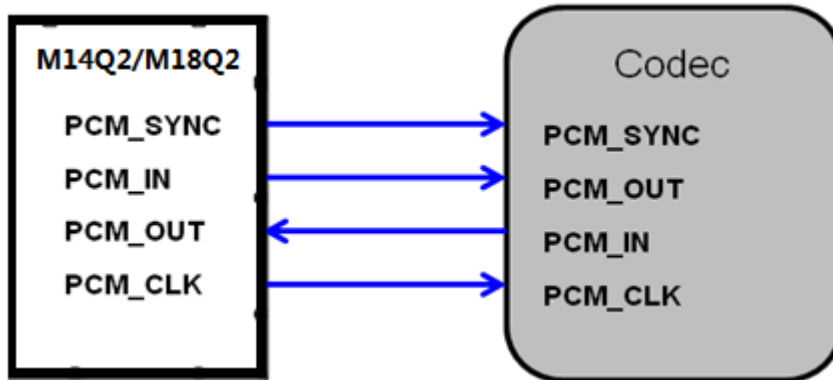

Figure 7. PCM connection (example)

**2.8.4. I2S Interface**

PCM and I2S share the same pins on the M14Q2F; the PCM signal pins can be configured as an I2S interface.

Config1	Config2
PCM_SYNC	I2S_WS
PCM_DIN	I2S_DATA0
PCM_DOUT	I2S_DATA1
PCM_CLK	I2S_SCK

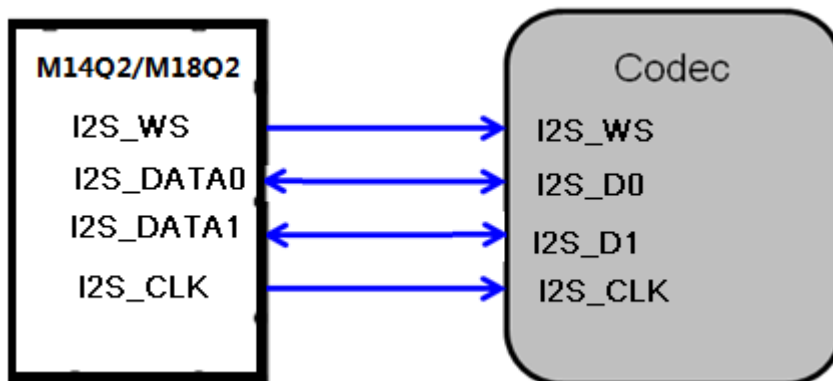

Figure 8. I2S connection (example)

### 2.8.5. I2C Interface

Adding pull-high resistors to 1.8 V through the 2.2 kΩ resistors is recommended.

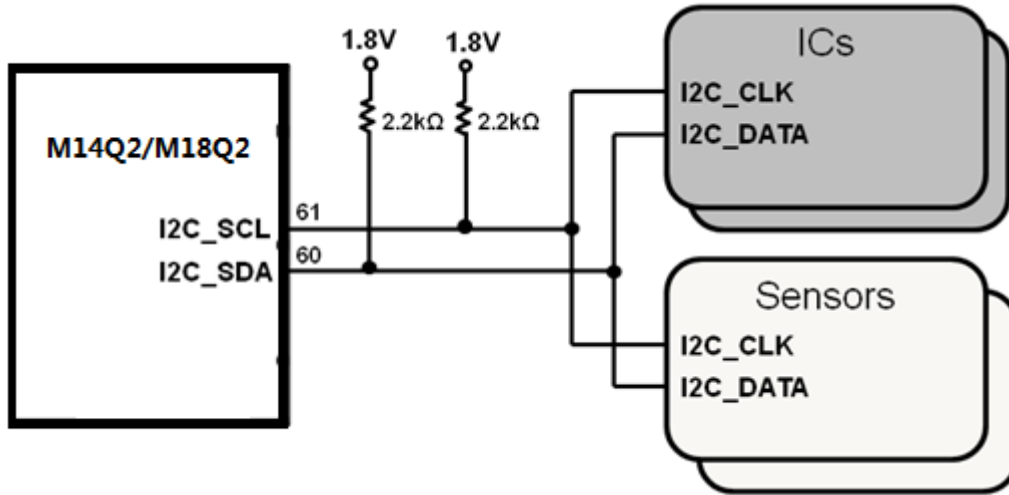

Figure 9. I2C connection (example)

### 2.8.6. UART Interface

There are two UART interfaces: One is a 4 bit UART for high-speed data transfer, and the other is a 2 bit UART for diagnostic tools and debugging.

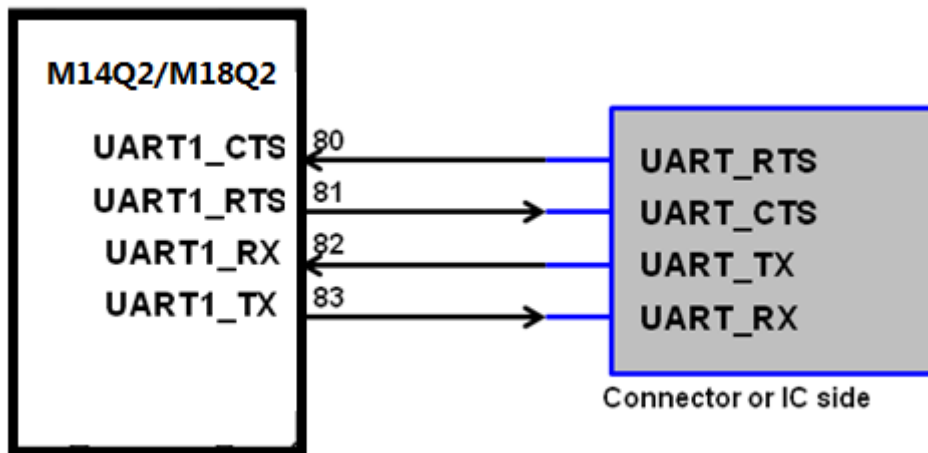

Figure 10. UART connection (example)

### 2.8.7. ADC Interface

An Analog to Digital Converter (ADC) input is provided by the M14Q2F. The converter is a 16 bit resolution, ranging from 0.1 V to 1.7 V, with a sampling rate of 2.4 MHz.

Parameter	Comments	Minimum	Typ	Maximum	Units
Supply voltage	Connected internally to VREG_L3	–	1.8	–	V
Resolution	Decimated data	–	–	15	bits
Analog-input bandwidth		–	100	–	kHz
Sample rate	XO/8	–	2.4	–	MHz
Offset error	Relative to full-scale	–1	–	+1	%
Gain error	Relative to full-scale	–1	–	+1	%
INL	15-bit output	–8	–	+8	LSB
DNL	15-bit output	–4	–	+4	LSB

#### Layout suggestion:

- Should be protected by GND
- Should be protected from noise and other easily radiated signals

### 3. RF Specifications

#### 3.1. RF connections

The M14Q2F has three RF pads; developers may connect them via 50 Ω traces to the main board.

ANT0\_TRX pad (Pin15) – Primary RX/TX path

ANT1\_DRX pad (Pin21) – Diversity path

ANT\_GNSS pad (Pin9) – NA

#### 3.2. RF Layout guidance

It is recommended that grounds not be present under the surface of the RF pads in the layout. Details are included below.

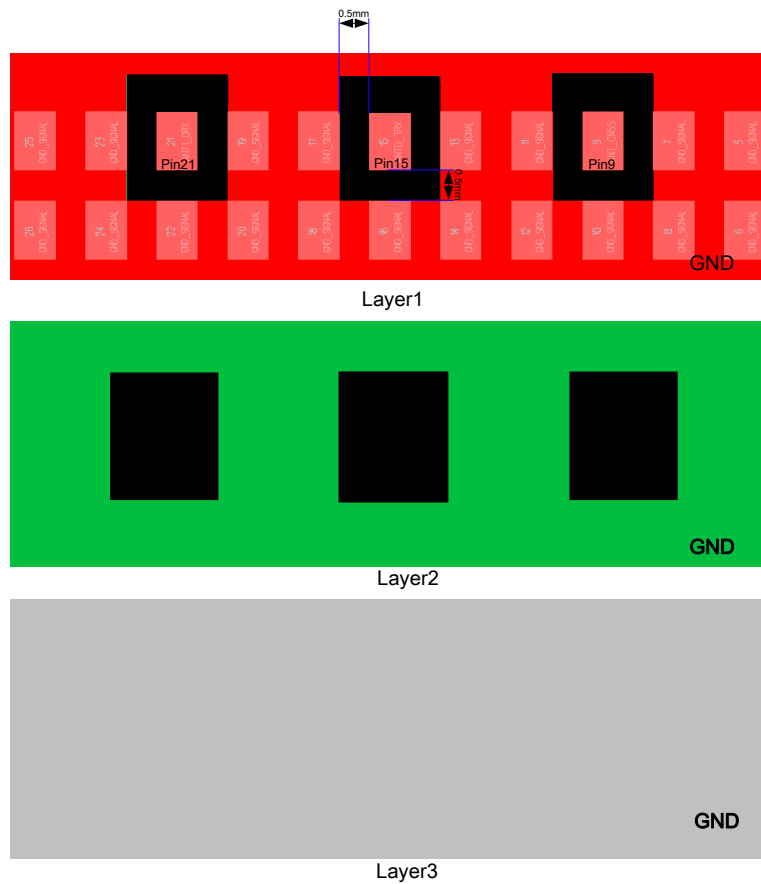

The RF trace between RF pads and antenna should be as short as possible with 50ohm characteristic impedance.

The characteristic impedance depends on the dielectric of PCB, the track width and the ground plane spacing. Microstrip type is required. The detail simulation as below.

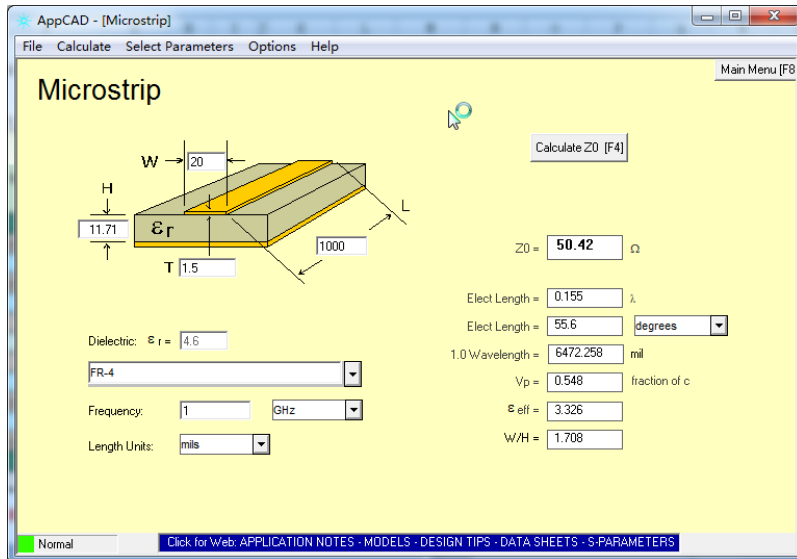

The RF trace of the test board which was used in the FCC test is defined as below.

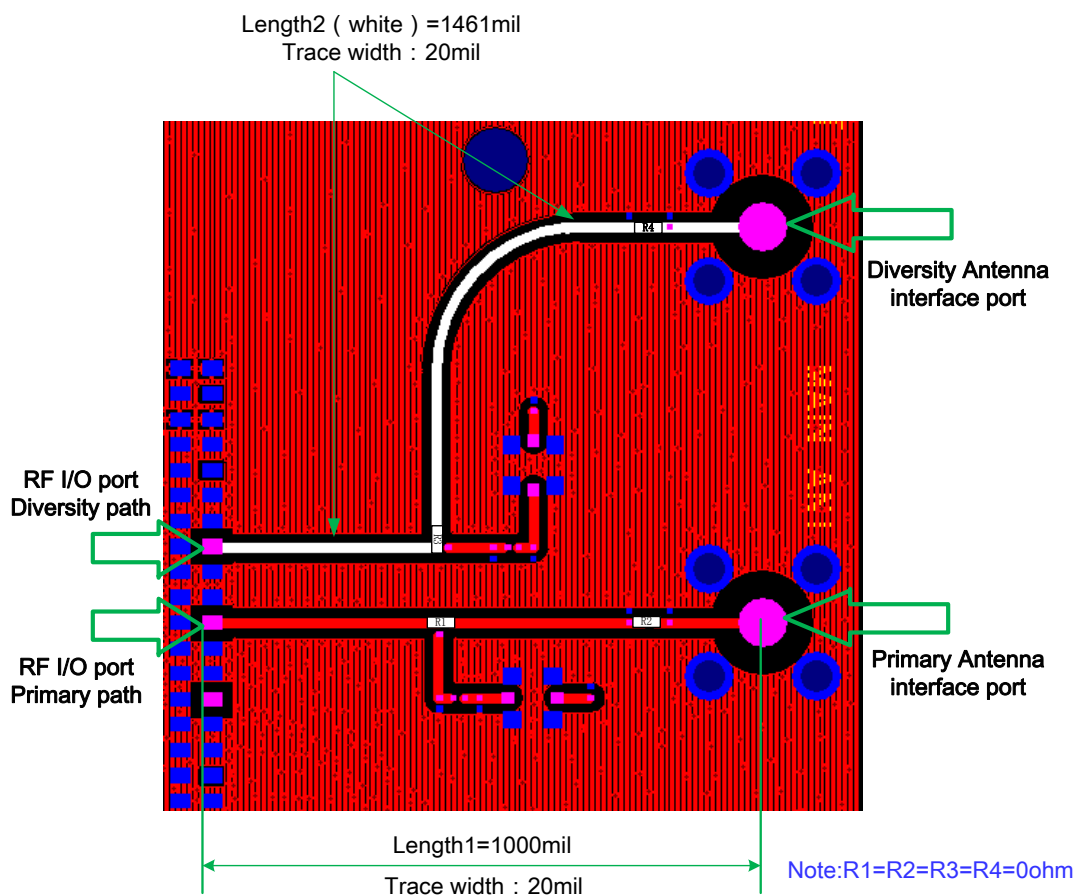

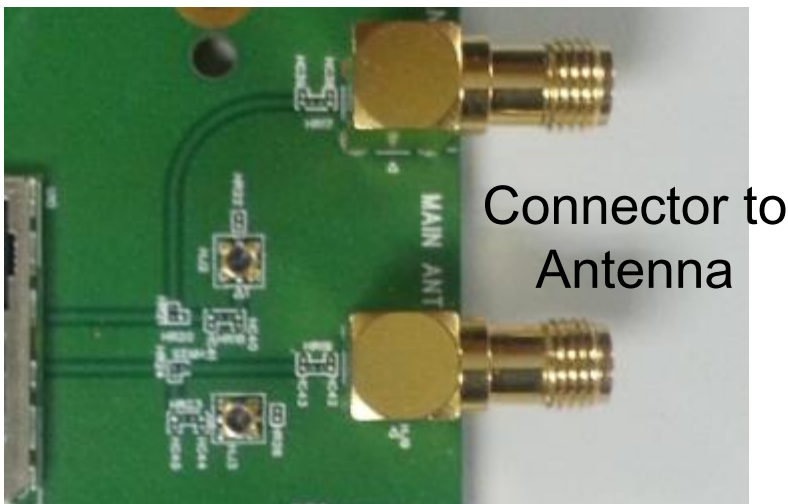

### 3.3. Antenna Guidance

The antenna should be 50ohm characteristic impedance with the return loss of better than -10dB at the operation band. The antenna gain would affect the radiated power and regulator test result.

### 3.4. Interference and sensitivity

This section includes tips to assist developers in identifying the interference that may affect the M14Q2F when is it used in systems.

#### ■ Interference from other wireless devices

- Harmonics, inter-modulated signal generated from wireless devices that fall in RX ranges of the M14Q2F, may result in degraded RX performance.
- It is highly recommended to check RX performance of entire systems within the shielding environment.

#### ■ Interference from host interface

- High-speed signal-switching elements in systems can easily couple noise into the module (Ex.: DDR memory, LCD modules, DC-DC converter).

#### ■ Methods to avoid sources of interference



- Antenna location is important; we recommend directing the antenna away from high-speed switching signals. Furthermore, the trace from the module to the antenna should be as short as possible and must be shielded by complete grounding.
- The M14Q2F is well shielded; the high-speed elements on a system should have shielding reserved during the early stages of development.

### 3.5. Radiated sensitivity measurement

Over-the-air testing can demonstrate the TRX ability of the whole system. Keys elements that affect the measurement are:

Module ability (refer Specification)

Antenna Gain

System noise source

The OTA performance should be performed in an OTA chamber.

### 3.6. Supported frequencies

Table 5. Band support

Band	Uplink (MHz)	Downlink (MHz)
LTE Band 2	1,850–1,910	1,930–1,990
LTE Band 4	1,710–1,755	2,110–2,155
LTE Band 5	824–849	869–894
LTE Band 12	699–716	729–746
Band	Uplink (MHz)	Downlink (MHz)
WCDMA Band 2	1,850–1,910	1,930–1,990
WCDMA Band 5	824–849	869–894

Table 6. Bandwidth support

Band	Bandwidth					
	1.4 MHz	3 MHz	5 MHz	10 MHz	15 MHz	20 MHz
LTE Band 2	✓	✓	✓	✓	✓	✓
LTE Band 4	✓	✓	✓	✓	✓	✓
LTE Band 5	✓	✓	✓	✓		
LTE Band 12	✓	✓	✓	✓		

Table 7. Conductive Rx sensitivity

Band	Items	Parameter	Unit	Min.	Typ.	Max.
LTE Band 2	Receive Sensitivity	10 MHz with 50 RBs	dBm			-94.3
LTE Band 4	Receive Sensitivity	10 MHz with 50 RBs	dBm			-96.3
LTE Band 5	Receive Sensitivity	10 MHz with 50 RBs	dBm			-94.3
LTE Band 12	Receive Sensitivity	10 MHz with 50 RBs	dBm			-93.3
Band	Items	Parameter	Unit	Min.	Typ.	Max.
WCDMA Band 2	Receive Sensitivity	-	dBm		-110	-104.7
WCDMA Band 5	Receive Sensitivity	-	dBm		-110	-104.7

## 4. Software Interface

### 4.1. Support tools

The M14Q2F is compatible with the following support tools:

- WNC M14Q2F Connection Manager (WNCCM)

### 4.2. USB interface

The M14Q2F supports 3GPP standard AT commands and proprietary AT commands; the MAL Manager SDK is also supported for Linux platforms.

## 5. Mechanical and Environmental Certifications

### 5.1. PCBA Form Factor

Dimensions 26.3 mm (typ.) × 23.1 mm (typ.) × 2.3 mm (typ.), tolerance: ± 0.15 mm

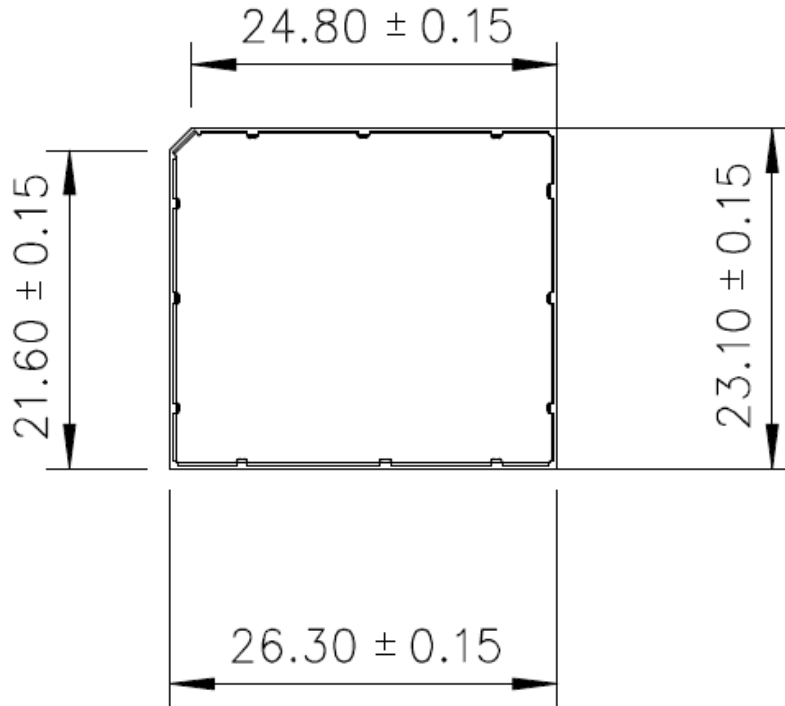

**Top view**

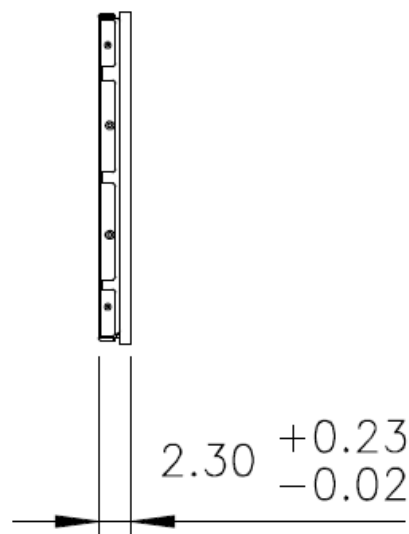

**Right view**

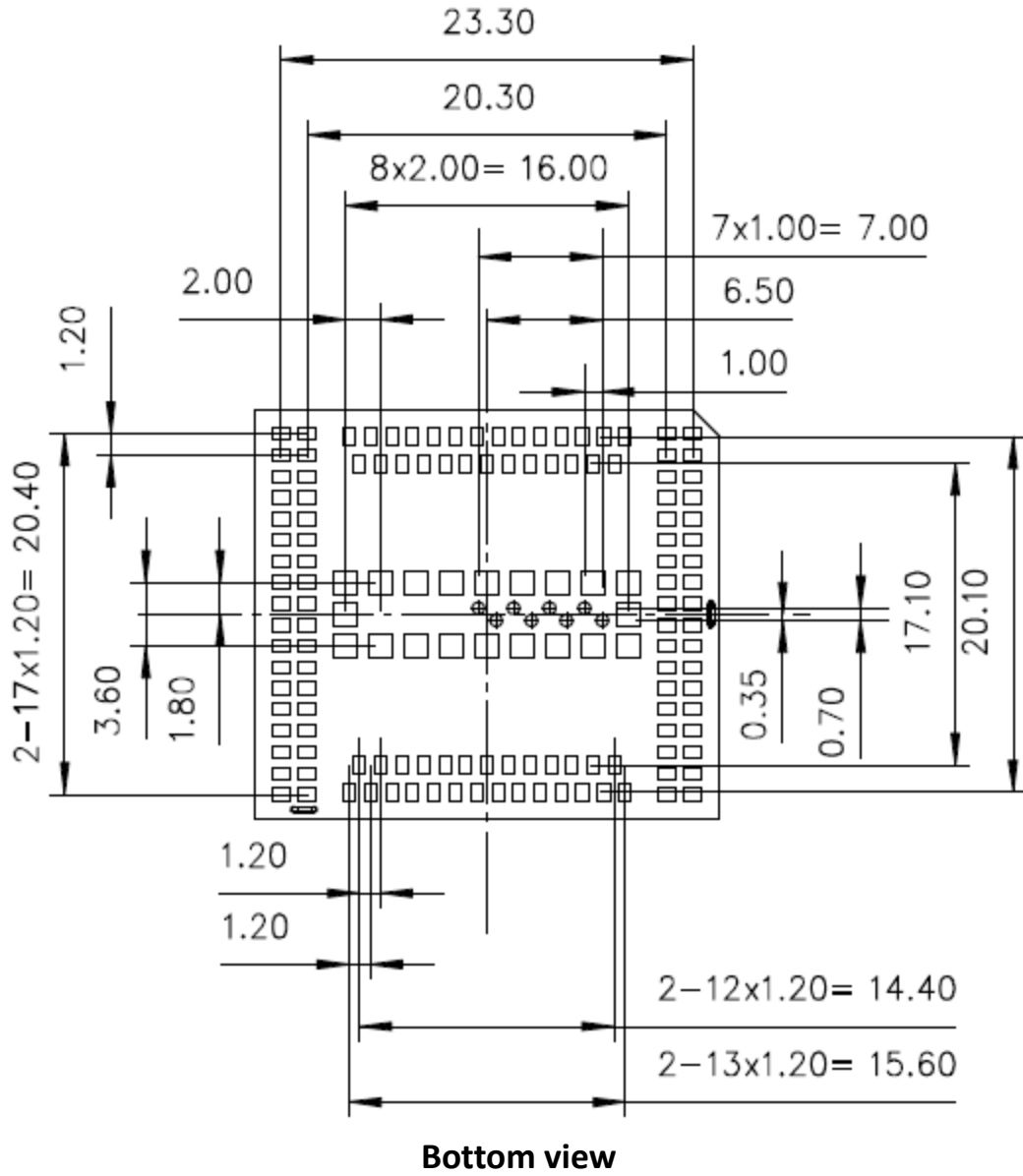

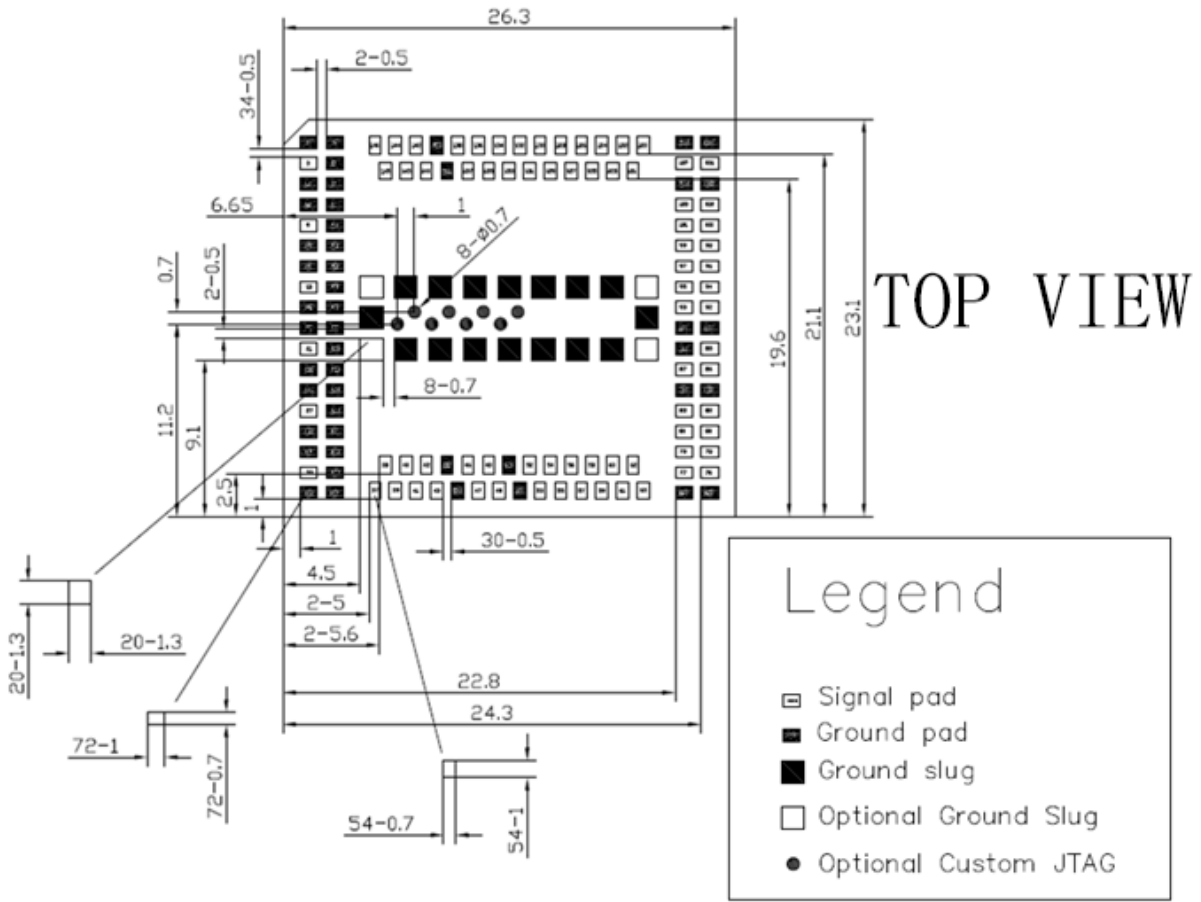

Pads location

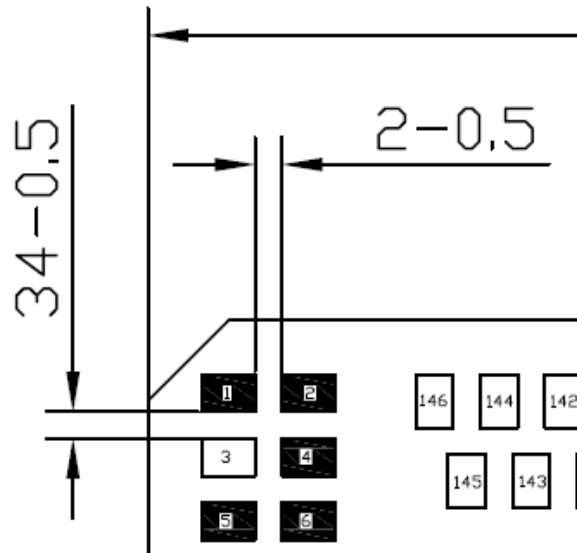

Pin1 location

Figure 11. PCBA dimensions

## 5.2. Labeling

When the module is installed in the host device, the FCC ID label must be visible through a window on the final device or it must be visible when an access panel, door or cover is easily re-moved. If not, a second label must be placed on the outside of the final device that contains the following text:

“Contains FCC ID: NKRM14Q2F”

The grantee's FCC ID can be used only when all FCC compliance requirements are met

## 6. Regulatory Compliance and Certification

### 6.1. Certification testing

PTCRB, FCC and AT&T TA



## 7. Safety Recommendation

Be sure the use of this product is allowed in the country and in the environment required. The use of this product may be dangerous and must be avoided in the following areas:

- Where it can interfere with other electronic devices in environments such as hospitals, airports, and aircraft
- Where there is a risk of explosion such as gasoline stations and oil refineries

It is the responsibility of the user to comply with his or her country's regulations and the specific environmental regulations.

Do not disassemble the product; any mark of tampering will compromise the warranty's validity.

We recommend following the instructions of the hardware user guides for a correct wiring of the product. The product must be supplied with a stabilized voltage source, and the wiring must conform to the security and fire-prevention regulations.

This product must be handled with care; avoid any contact with the pins because electrostatic discharge may damage the product. Same caution must be taken regarding the SIM card; carefully check the instructions for its use. Do not insert or remove the SIM when the product is in power-saving mode.

The system integrator is responsible of the functioning of the final product; therefore, care must be taken for the external components of the module as well as for project or installation issues—there may be a risk of disturbing the GSM network or external devices or of having an impact on device security. If you have any doubts, please refer to the technical documentation and the relevant regulations in force.

Every module must be equipped with a proper antenna with specific characteristics. The antenna must be installed with care in order to avoid any interference with other electronic devices.