

FCC Test Report

(PART 27)

Report No.: RF181005C08-3

FCC ID: NKRIMQ3

Test Model: IMQ3-2

Series Model: IMQ3-0, IMQ3-1, IMQ3-3 (See section 3.1 for more detail)

Received Date: Oct. 05, 2018

Test Date: Jan. 04, 2019 ~ Jan. 15, 2019

Issued Date: Jan. 25, 2019

Applicant: Wistron NeWeb Corporation

Address: 20 Park Avenue II, Hsinchu Science Park, Hsinchu 308, Taiwan, R.O.C

Issued By: Bureau Veritas Consumer Products Services (H.K.) Ltd., Taoyuan Branch

Lab Address: No. 47-2, 14th Ling, Chia Pau Vil., Lin Kou Dist., New Taipei City, Taiwan (R.O.C)

Test Location: No. 19, Hwa Ya 2nd Rd, Wen Hwa Vil, Kwei Shan Dist., Taoyuan City 33383, Taiwan (R.O.C)

**FCC Registration /
Designation Number:** 788550 / TW0003



This report is for your exclusive use. Any copying or replication of this report to or for any other person or entity, or use of our name or trademark, is permitted only with our prior written permission. This report sets forth our findings solely with respect to the test samples identified herein. The results set forth in this report are not indicative or representative of the quality or characteristics of the lot from which a test sample was taken or any similar or identical product unless specifically and expressly noted. Our report includes all of the tests requested by you and the results thereof based upon the information that you provided to us. You have 60 days from date of issuance of this report to notify us of any material error or omission caused by our negligence, provided, however, that such notice shall be in writing and shall specifically address the issue you wish to raise. A failure to raise such issue within the prescribed time shall constitute your unqualified acceptance of the completeness of this report, the tests conducted and the correctness of the report contents. Unless specific mention, the uncertainty of measurement has been explicitly taken into account to declare the compliance or non-compliance to the specification. The report must not be used by the client to claim product certification, approval, or endorsement by TAF or any government agencies

Table of Contents

Release Control Record	4
1 Certificate of Conformity	5
2 Summary of Test Results	6
2.1 Measurement Uncertainty	7
2.2 Test Site and Instruments	8
3 General Information	10
3.1 General Description of EUT	10
3.2 Configuration of System under Test	12
3.2.1 Description of Support Units	12
3.3 Test Mode Applicability and Tested Channel Detail	13
3.4 EUT Operating Conditions	17
3.5 General Description of Applied Standards	17
4 Test Types and Results	18
4.1 Output Power Measurement	18
4.1.1 Limits of Output Power Measurement	18
4.1.2 Test Procedures	18
4.1.3 Test Setup	19
4.1.4 Test Results	20
4.2 Modulation Characteristics Measurement	44
4.2.1 Limits of Modulation Characteristics	44
4.2.2 Test Setup	44
4.2.3 Test Procedure	44
4.2.4 Test Results	45
4.3 Frequency Stability Measurement	46
4.3.1 Limits of Frequency Stability Measurement	46
4.3.2 Test Procedure	46
4.3.3 Test Setup	46
4.3.4 Test Results	47
4.4 Occupied Bandwidth Measurement	59
4.4.1 Limits of Occupied Bandwidth Measurement	59
4.4.2 Test Procedure	59
4.4.3 Test Setup	59
4.4.4 Test Result	60
4.5 Band Edge Measurement	66
4.5.1 Limits of Band Edge Measurement	66
4.5.2 Test Setup	66
4.5.3 Test Procedures	66
4.5.4 Test Results	67
4.6 Peak to Average Ratio	81
4.6.1 Limits of Peak to Average Ratio Measurement	81
4.6.2 Test Setup	81
4.6.3 Test Procedures	81
4.6.4 Test Results	82
4.7 Conducted Spurious Emissions	88
4.7.1 Limits of Conducted Spurious Emissions Measurement	88
4.7.2 Test Setup	88
4.7.3 Test Procedure	88
4.7.4 Test Results	89
4.8 Radiated Emission Measurement	115
4.8.1 Limits of Radiated Emission Measurement	115
4.8.2 Test Procedure	115
4.8.3 Deviation from Test Standard	115
4.8.4 Test Setup	116

4.8.5 Test Results	117
5 Pictures of Test Arrangements.....	161
Appendix – Information of the Testing Laboratories	162

Release Control Record

Issue No.	Description	Date Issued
RF181005C08-3	Original Release	Jan. 25, 2019

1 Certificate of Conformity

Product: M2M DATA MODULE

Brand: WNC

Test Model: IMQ3-2

Series Model: IMQ3-0, IMQ3-1, IMQ3-3 (See section 3.1 for more detail)

Sample Status: Engineering Sample

Applicant: Wistron NeWeb Corporation

Test Date: Jan. 04, 2019 ~ Jan. 15, 2019

Standards: FCC Part 27, Subpart H, F, L

The above equipment has been tested by **Bureau Veritas Consumer Products Services (H.K.) Ltd., Taoyuan Branch**, and found compliance with the requirement of the above standards. The test record, data evaluation & Equipment Under Test (EUT) configurations represented herein are true and accurate accounts of the measurements of the sample's RF characteristics under the conditions specified in this report.

Prepared by : , **Date:** Jan. 25, 2019
Lena Wang / Specialist

Approved by : , **Date:** Jan. 25, 2019
Dylan Chiou / Project Engineer

2 Summary of Test Results

Applied Standard: FCC Part 27 & Part 2 (LTE 4)			
FCC Clause	Test Item	Result	Remarks
2.1046 27.50(d)(4)	Maximum Peak Output Power	Pass	Meet the requirement of limit.
2.1047	Modulation Characteristics	Pass	Meet the requirement.
2.1055 27.54	Frequency Stability	Pass	Meet the requirement of limit.
2.1049 27.53(h)	Occupied Bandwidth	Pass	Meet the requirement of limit.
27.50(d)(5)	Peak to Average Ratio	Pass	Meet the requirement of limit.
27.53(h)	Band Edge Measurements	Pass	Meet the requirement of limit.
2.1051 27.53(h)	Conducted Spurious Emissions	Pass	Meet the requirement of limit.
2.1053 27.53(h)	Radiated Spurious Emissions	Pass	Meet the requirement of limit. Minimum passing margin is -27.74 dB at 5235.00 MHz.

Applied Standard: FCC Part 27 & Part 2 (LTE 12)			
FCC Clause	Test Item	Result	Remarks
2.1046 27.50(c)(10)	Maximum Peak Output Power	Pass	Meet the requirement of limit.
2.1047	Modulation Characteristics	Pass	Meet the requirement.
2.1055 27.54	Frequency Stability	Pass	Meet the requirement of limit.
2.1049	Occupied Bandwidth	Pass	Meet the requirement of limit.
27.50(d)(5)	Peak to Average Ratio	Pass	Meet the requirement of limit.
27.53(g)	Band Edge Measurements	Pass	Meet the requirement of limit.
2.1051 27.53(g)	Conducted Spurious Emissions	Pass	Meet the requirement of limit.
2.1053 27.53(g)	Radiated Spurious Emissions	Pass	Meet the requirement of limit. Minimum passing margin is -31.62 dB at 1422.00 MHz.

Applied Standard: FCC Part 27 & Part 2 (LTE 13)			
FCC Clause	Test Item	Result	Remarks
2.1046 27.50(b)(10)	Maximum Peak Output Power	Pass	Meet the requirement of limit.
2.1047	Modulation Characteristics	Pass	Meet the requirement.
2.1055 27.54	Frequency Stability	Pass	Meet the requirement of limit.
2.1049	Occupied Bandwidth	Pass	Meet the requirement of limit.
27.50(d)(5)	Peak to Average Ratio	Pass	Meet the requirement of limit.
27.53(c)(2)(4)	Band Edge Measurements	Pass	Meet the requirement of limit.
2.1051 27.53(c)(2) &(f)	Conducted Spurious Emissions	Pass	Meet the requirement of limit.
2.1053 27.53(c)(2)&(f)	Radiated Spurious Emissions	Pass	Meet the requirement of limit. Minimum passing margin is -4.19 dB at 1564.00 MHz.

Note: Determining compliance based on the results of the compliance measurement, not taking into account measurement instrumentation uncertainty.

2.1 Measurement Uncertainty

Where relevant, the following measurement uncertainty levels have been estimated for tests performed on the EUT as specified in CISPR 16-4-2:

Measurement	Frequency	Expanded Uncertainty (k=2) (\pm)
Radiated Emissions up to 1 GHz	30 MHz ~ 200 MHz	2.93 dB
	200 MHz ~ 1000 MHz	2.95 dB
Radiated Emissions above 1 GHz	1 GHz ~ 18 GHz	2.26 dB
	18 GHz ~ 40 GHz	1.94 dB

2.2 Test Site and Instruments

Description & Manufacturer	Model No.	Serial No.	Date of Calibration	Due Date of Calibration
Test Receiver Agilent	N9038A	MY51210203	Mar. 16, 2018	Mar. 15, 2019
Spectrum Analyzer Agilent	N9010A	MY52220314	Dec. 13, 2018	Dec. 12, 2019
Spectrum Analyzer ROHDE & SCHWARZ	FSU43	101261	Jan. 11, 2018	Jan. 10, 2019
HORN Antenna SCHWARZBECK	BBHA 9120D	9120D-969	Nov. 25, 2018	Nov. 24, 2019
BILOG Antenna SCHWARZBECK	VULB 9168	9168-472	Nov. 23, 2018	Nov. 22, 2019
Fixed Attenuator Mini-Circuits	MDCS18N-10	MDCS18N-10-01	Apr. 16, 2018	Apr. 15, 2019
MXG Vector signal generator Agilent	N5182B	MY53050430	Nov. 19, 2018	Nov. 18, 2019
Preamplifier EMCI	EMC 012645	980115	Oct. 12, 2018	Oct. 11, 2019
Preamplifier EMCI	EMC 330H	980112	Oct. 12, 2018	Oct. 11, 2019
RF Coaxial Cable HUBER+SUHNNER	EMC104-SM-SM- 8000&3000	140811+170717	Oct. 12, 2018	Oct. 11, 2019
RF Coaxial Cable HUBER+SUHNNER	SUCOFLEX 104	EMC104-SM-SM- 1000(140807)	Oct. 12, 2018	Oct. 11, 2019
RF Coaxial Cable WOKEN	8D-FB	Cable-Ch10-01	Oct. 12, 2018	Oct. 11, 2019
Boresight Antenna Fixture	FBA-01	FBA-SIP01	NA	NA
Software BV ADT	E3 6.120103	NA	NA	NA
Antenna Tower MF	MFA-440H	NA	NA	NA
Turn Table MF	MFT-201SS	NA	NA	NA
Antenna Tower & Turn Table Controller MF	MF-7802	NA	NA	NA
LTE Wireless Communication Test Set Keysight	E7515A	MY56030229	Mar. 14, 2018	Mar. 13, 2019
Radio Communication Analyzer Anritsu	MT8821C	6201502978	Jul. 20, 2018	Jul. 19, 2019
Temperature & Humidity Chamber	GTH-120-40-CP-AR	MAA1306-019	Sep. 05, 2018	Sep. 04, 2019
DC Power Supply Agilent	66319D	MY43005576	Oct. 19, 2018	Oct. 18, 2019

- Note:
1. The calibration interval of the above test instruments is 12 / 24 months and the calibrations are traceable to NML/ROC and NIST/USA.
 2. The test was performed in HwaYa Chamber 10.
 3. The horn antenna and preamplifier (model: EMC 184045) are used only for the measurement of emission frequency above 1 GHz if tested.
 4. The IC Site Registration No. is 7450F-10.

3 General Information

3.1 General Description of EUT

Product	M2M DATA MODULE	
Brand	WNC	
Test Model	IMQ3-2	
Series Model	IMQ3-0, IMQ3-1, IMQ3-3	
Status of EUT	Engineering Sample	
Power Supply Rating	3.8 Vdc	
Modulation Type	LTE	QPSK, 16QAM
Frequency Range	LTE Band 4 (Channel Bandwidth: 1.4 MHz)	1710.7 ~ 1754.3 MHz
	LTE Band 4 (Channel Bandwidth: 3 MHz)	1711.5 ~ 1753.5 MHz
	LTE Band 4 (Channel Bandwidth: 5 MHz)	1712.5 ~ 1752.5 MHz
	LTE Band 4 (Channel Bandwidth: 10 MHz)	1715.0 ~ 1750.0 MHz
	LTE Band 4 (Channel Bandwidth: 15 MHz)	1717.5 ~ 1747.5 MHz
	LTE Band 4 (Channel Bandwidth: 20 MHz)	1720.0 ~ 1745.0 MHz
	LTE Band 12 (Channel Bandwidth: 1.4 MHz)	699.7 ~ 715.3 MHz
	LTE Band 12 (Channel Bandwidth: 3 MHz)	700.5 ~ 714.5 MHz
	LTE Band 12 (Channel Bandwidth: 5 MHz)	701.5 ~ 713.5 MHz
	LTE Band 12 (Channel Bandwidth: 10 MHz)	704.0 ~ 711.0 MHz
	LTE Band 13 (Channel Bandwidth: 5 MHz)	779.5 ~ 784.5 MHz
	LTE Band 13 (Channel Bandwidth: 10 MHz)	782.0 MHz
Emission Designator	LTE Band 4 (Channel Bandwidth: 1.4 MHz)	1M09G7D
	LTE Band 4 (Channel Bandwidth: 3 MHz)	1M09G7D
	LTE Band 4 (Channel Bandwidth: 5 MHz)	1M08G7D
	LTE Band 4 (Channel Bandwidth: 10 MHz)	1M09G7D
	LTE Band 4 (Channel Bandwidth: 15 MHz)	1M09G7D
	LTE Band 4 (Channel Bandwidth: 20 MHz)	1M09G7D
	LTE Band 12 (Channel Bandwidth: 1.4 MHz)	1M09G7D
	LTE Band 12 (Channel Bandwidth: 3 MHz)	1M09G7D
	LTE Band 12 (Channel Bandwidth: 5 MHz)	1M09G7D
	LTE Band 12 (Channel Bandwidth: 10 MHz)	1M09G7D
	LTE Band 13 (Channel Bandwidth: 5 MHz)	1M08G7D
	LTE Band 13 (Channel Bandwidth: 10 MHz)	1M09G7D
Max. ERP Power	LTE Band 12 (Channel Bandwidth: 1.4 MHz)	91.83 mW
	LTE Band 12 (Channel Bandwidth: 3 MHz)	97.50 mW
	LTE Band 12 (Channel Bandwidth: 5 MHz)	103.04 mW
	LTE Band 12 (Channel Bandwidth: 10 MHz)	109.14 mW
	LTE Band 13 (Channel Bandwidth: 5 MHz)	99.31 mW
	LTE Band 13 (Channel Bandwidth: 10 MHz)	105.93 mW
Max. EIRP Power	LTE Band 4 (Channel Bandwidth: 1.4 MHz)	200.91 mW
	LTE Band 4 (Channel Bandwidth: 3 MHz)	213.80 mW
	LTE Band 4 (Channel Bandwidth: 5 MHz)	226.99 mW
	LTE Band 4 (Channel Bandwidth: 10 MHz)	240.44 mW
	LTE Band 4 (Channel Bandwidth: 15 MHz)	255.27 mW
	LTE Band 4 (Channel Bandwidth: 20 MHz)	269.77 mW
Antenna Type	Dipole Antenna	

Antenna Gain	LTE Band 4	0.6 dBi
	LTE Band 12	-3.5 dBi
	LTE Band 13	-3.5 dBi
Accessory Device	N/A	
Data Cable Supplied	N/A	

Note:

1. All models are listed as below. Model IMQ3-2 was chosen for final test and present in the report.

Brand	Model	Difference
WNC	IMQ3-2	LTE M1+2G+GPS
	IMQ3-0	LTE M1+GPS
	IMQ3-1	LTE M1+2G
	IMQ3-3	LTE M1

2. The above EUT information is declared by manufacturer and for more detailed features description, please refers to the manufacturer's specifications or user's manual.
3. In addition to Frequency Stability Measurement, the other tests are tested with Adapter (12 Vdc).

3.2 Configuration of System under Test

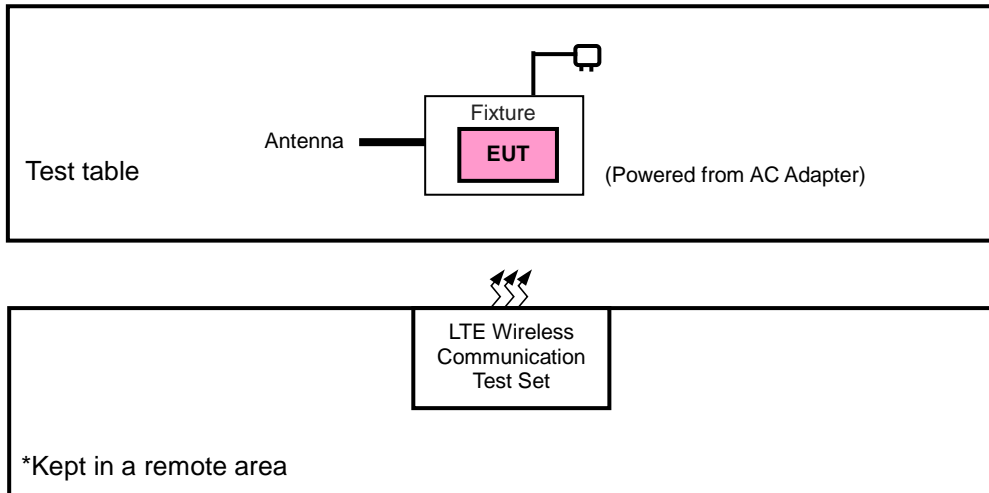

3.2.1 Description of Support Units

The EUT has been tested as an independent unit together with other necessary accessories or support units. The following support units or accessories were used to form a representative test configuration during the tests.

No.	Product	Brand	Model No.	Serial No.	FCC ID
1.	LTE Wireless Communication Test Set	Keysight	E7515A	MY56030229	N/A
2.	Adapter	Asian Power Devices Inc.	WA-24Q12FU	N/A	N/A
3.	Antenna	Cortec	AN0727-6706BSM	N/A	N/A
4.	DC Power Supply	Agilent	66319D	MY43005576	N/A

No.	Signal Cable Description Of The Above Support Units
1.	N/A
2.	N/A
3.	N/A
4.	N/A

Note:

1. All power cords of the above support units are non-shielded (1.8m).
2. Items 1 acted as communication partners to transfer data.
3. Item 2 & 3 was provided by client.

3.3 Test Mode Applicability and Tested Channel Detail

Pre-Scan has been conducted to determine the worst-case mode from all possible combinations between available modulations, data rates, XYZ axis, and antenna ports

The worst case was found when positioned as the table below. Following channel(s) was (were) selected for the final test as listed below:

Band	ERP / EIRP	Radiated Emission
LTE Band 4	X-plane	Z-axis
LTE Band 12	X-plane	X-axis
LTE Band 13	X-plane	X-axis

LTE Band 4

EUT Configure Mode	Test Item	Available Channel	Tested Channel	Channel Bandwidth	Modulation	Mode
-	EIRP	19957 to 20393	19957, 20175, 20393	1.4 MHz	QPSK, 16QAM	1 RB / 5 RB Offset
		19965 to 20385	19965, 20175, 20385	3 MHz	QPSK, 16QAM	1 RB / 0 RB Offset
		19975 to 20375	19975, 20175, 20375	5 MHz	QPSK, 16QAM	1 RB / 5 RB Offset
		20000 to 20350	20000, 20175, 20350	10 MHz	QPSK, 16QAM	1 RB / 5 RB Offset
		20025 to 20325	20025, 20175, 20325	15 MHz	QPSK, 16QAM	1 RB / 0 RB Offset
		20050 to 20300	20050, 20175, 20300	20 MHz	QPSK, 16QAM	1 RB / 0 RB Offset
-	Modulation Characteristics	20050 to 20300	20175	5 MHz	QPSK, 16QAM	1 RB / 0 RB Offset
-	Frequency Stability	19957 to 20393	19957, 20393	1.4 MHz	QPSK	1 RB / 0 RB Offset
		19965 to 20385	19965, 20385	3 MHz	QPSK	1 RB / 0 RB Offset
		19975 to 20375	19975, 20375	5 MHz	QPSK	1 RB / 0 RB Offset
		20000 to 20350	20000, 20350	10 MHz	QPSK	1 RB / 0 RB Offset
		20025 to 20325	20025, 20325	15 MHz	QPSK	1 RB / 0 RB Offset
		20050 to 20300	20050, 20300	20 MHz	QPSK	1 RB / 0 RB Offset
-	Occupied Bandwidth	19957 to 20393	19957, 20175, 20393	1.4 MHz	QPSK, 16QAM	6 RB / 0 RB Offset
		19965 to 20385	19965, 20175, 20385	3 MHz	QPSK, 16QAM	6 RB / 0 RB Offset
		19975 to 20375	19975, 20175, 20375	5 MHz	QPSK, 16QAM	6 RB / 0 RB Offset
		20000 to 20350	20000, 20175, 20350	10 MHz	QPSK, 16QAM	6 RB / 0 RB Offset
		20025 to 20325	20025, 20175, 20325	15 MHz	QPSK, 16QAM	6 RB / 0 RB Offset
		20050 to 20300	20050, 20175, 20300	20 MHz	QPSK, 16QAM	6 RB / 0 RB Offset
-	Peak to Average Ratio	19957 to 20393	19957, 20175, 20393	1.4 MHz	QPSK, 16QAM	1 RB / 0 RB Offset
		19965 to 20385	19965, 20175, 20385	3 MHz	QPSK, 16QAM	1 RB / 0 RB Offset
		19975 to 20375	19975, 20175, 20375	5 MHz	QPSK, 16QAM	1 RB / 0 RB Offset
		20000 to 20350	20000, 20175, 20350	10 MHz	QPSK, 16QAM	1 RB / 0 RB Offset
		20025 to 20325	20025, 20175, 20325	15 MHz	QPSK, 16QAM	1 RB / 0 RB Offset
		20050 to 20300	20050, 20175, 20300	20 MHz	QPSK, 16QAM	1 RB / 0 RB Offset

EUT Configure Mode	Test Item	Available Channel	Tested Channel	Channel Bandwidth	Modulation	Mode		
-	Band Edge	19957 to 20393	19957	1.4 MHz	QPSK	1 RB / 0 RB Offset		
			20393	1.4 MHz		6 RB / 0 RB Offset		
		19965 to 20385	19965	3 MHz	QPSK	1 RB / 5 RB Offset		
			20385	3 MHz		6 RB / 0 RB Offset		
		19975 to 20375	19975	5 MHz	QPSK	1 RB / 0 RB Offset		
			20375	5 MHz		6 RB / 0 RB Offset		
		20000 to 20350	20000	10 MHz	QPSK	1 RB / 5 RB Offset		
			20350	10 MHz		6 RB / 0 RB Offset		
		20025 to 20325	20025	15 MHz	QPSK	1 RB / 0 RB Offset		
			20325	15 MHz		6 RB / 0 RB Offset		
		20050 to 20300	20050	20 MHz	QPSK	1 RB / 5 RB Offset		
			20300	20 MHz		6 RB / 0 RB Offset		
		-	Conducted Emission	19957 to 20393	19957, 20175, 20393	1.4 MHz	QPSK	1 RB / 5 RB Offset
				19965 to 20385	19965, 20175, 20385	3 MHz		1 RB / 0 RB Offset
				19975 to 20375	19975, 20175, 20375	5 MHz		1 RB / 5 RB Offset
				20000 to 20350	20000, 20175, 20350	10 MHz		1 RB / 0 RB Offset
				20025 to 20325	20025, 20175, 20325	15 MHz		1 RB / 5 RB Offset
				20050 to 20300	20050, 20175, 20300	20 MHz		1 RB / 0 RB Offset
-	Radiated Emission	19957 to 20393	19957, 20175, 20393	1.4 MHz	QPSK	1 RB / 5 RB Offset		
		19975 to 20375	19975, 20175, 20375	5 MHz		1 RB / 0 RB Offset		
		20050 to 20300	20050, 20175, 20300	20 MHz		1 RB / 5 RB Offset		

Note: This device was tested under all bandwidths, RB configurations and modulations. The worst case was found in QPSK modulation.

LTE Band 12

EUT Configure Mode	Test Item	Available Channel	Tested Channel	Channel Bandwidth	Modulation	Mode		
-	ERP	23017 to 23173	23017, 23095, 23173	1.4 MHz	QPSK, 16QAM	1 RB / 5 RB Offset		
		23025 to 23165	23025, 23095, 23165	3 MHz	QPSK, 16QAM	1 RB / 5 RB Offset		
		23035 to 23155	23035, 23095, 23155	5 MHz	QPSK, 16QAM	1 RB / 5 RB Offset		
		23060 to 23130	23060, 23095, 23130	10 MHz	QPSK, 16QAM	1 RB / 0 RB Offset		
-	Modulation Characteristics	23060 to 23130	23095	5 MHz	QPSK, 16QAM	1 RB / 0 RB Offset		
-	Frequency Stability	23017 to 23173	23017, 23173	1.4 MHz	QPSK	1 RB / 0 RB Offset		
		23025 to 23165	23025, 23165	3 MHz	QPSK	1 RB / 0 RB Offset		
		23035 to 23155	23035, 23155	5 MHz	QPSK	1 RB / 0 RB Offset		
		23060 to 23130	23060, 23130	10 MHz	QPSK	1 RB / 0 RB Offset		
-	Occupied Bandwidth	23017 to 23173	23017, 23095, 23173	1.4 MHz	QPSK, 16QAM	6 RB / 0 RB Offset		
		23025 to 23165	23025, 23095, 23165	3 MHz	QPSK, 16QAM	6 RB / 0 RB Offset		
		23035 to 23155	23035, 23095, 23155	5 MHz	QPSK, 16QAM	6 RB / 0 RB Offset		
		23060 to 23130	23060, 23095, 23130	10 MHz	QPSK, 16QAM	6 RB / 0 RB Offset		
-	Peak to Average Ratio	23017 to 23173	23017, 23095, 23173	1.4 MHz	QPSK, 16QAM	1 RB / 0 RB Offset		
		23025 to 23165	23025, 23095, 23165	3 MHz	QPSK, 16QAM	1 RB / 0 RB Offset		
		23035 to 23155	23035, 23095, 23155	5 MHz	QPSK, 16QAM	1 RB / 0 RB Offset		
		23060 to 23130	23060, 23095, 23130	10 MHz	QPSK, 16QAM	1 RB / 0 RB Offset		
-	Band Edge	23017 to 23173	23017	1.4 MHz	QPSK	1 RB / 0 RB Offset		
			23173	1.4 MHz	QPSK	6 RB / 0 RB Offset		
		23025 to 23165	23025	3 MHz	QPSK	1 RB / 5 RB Offset		
			23165	3 MHz	QPSK	6 RB / 0 RB Offset		
		23035 to 23155	23035	5 MHz	QPSK	1 RB / 0 RB Offset		
			23155	5 MHz	QPSK	6 RB / 0 RB Offset		
		23060 to 23130	23060	10 MHz	QPSK	1 RB / 5 RB Offset		
			23130	10 MHz	QPSK	6 RB / 0 RB Offset		
		-	Conducted Emission	23017 to 23173	23017, 23095, 23173	1.4 MHz	QPSK	1 RB / 5 RB Offset
				23025 to 23165	23025, 23095, 23165	3 MHz	QPSK	1 RB / 5 RB Offset
				23035 to 23155	23035, 23095, 23155	5 MHz	QPSK	1 RB / 5 RB Offset
				23060 to 23130	23060, 23095, 23130	10 MHz	QPSK	1 RB / 0 RB Offset
-	Radiated Emission	23017 to 23173	23017, 23095, 23173	1.4 MHz	QPSK	1 RB / 5 RB Offset		
		23035 to 23155	23035, 23095, 23155	5 MHz	QPSK	1 RB / 5 RB Offset		
		23060 to 23130	23060, 23095, 23130	10 MHz	QPSK	1 RB / 0 RB Offset		

Note: This device was tested under all bandwidths, RB configurations and modulations. The worst case was found in QPSK modulation.

LTE Band 13

EUT Configure Mode	Test Item	Available Channel	Tested Channel	Channel Bandwidth	Modulation	Mode
-	ERP	23205 to 23255	23205, 23230, 23255	5 MHz	QPSK, 16QAM	1 RB / 0 RB Offset
		23230	23230	10 MHz	QPSK, 16QAM	1 RB / 5 RB Offset
-	Modulation Characteristics	23230	23230	5 MHz	QPSK, 16QAM	1 RB / 0 RB Offset
-	Frequency Stability	23205 to 23255	23205, 23255	5 MHz	QPSK	1 RB / 0 RB Offset
		23230	23230	10 MHz	QPSK	1 RB / 0 RB Offset
-	Occupied Bandwidth	23205 to 23255	23205, 23230, 23255	5 MHz	QPSK, 16QAM	6 RB / 0 RB Offset
		23230	23230	10 MHz	QPSK, 16QAM	6 RB / 0 RB Offset
-	Peak to Average Ratio	23205 to 23255	23205, 23230, 23255	5 MHz	QPSK, 16QAM	1 RB / 0 RB Offset
		23230	23230	10 MHz	QPSK, 16QAM	1 RB / 0 RB Offset
-	Band Edge	23205 to 23255	23205	5 MHz	QPSK	1 RB / 0 RB Offset
			23255	5 MHz	QPSK	6 RB / 0 RB Offset
		23230	23230	10 MHz	QPSK	1 RB / 5 RB Offset
			23230	10 MHz	QPSK	6 RB / 0 RB Offset
		23230	23230	10 MHz	QPSK	1 RB / 0 RB Offset
			23230	10 MHz	QPSK	6 RB / 0 RB Offset
-	Conducted Emission	23205 to 23255	23205, 23230, 23255	5 MHz	QPSK	1 RB / 0 RB Offset
		23230	23230	10 MHz	QPSK	1 RB / 5 RB Offset
-	Radiated Emission	23205 to 23255	23205, 23230, 23255	5 MHz	QPSK	1 RB / 0 RB Offset
		23230	23230	10 MHz	QPSK	1 RB / 5 RB Offset

Note: This device was tested under all bandwidths, RB configurations and modulations. The worst case was found in QPSK modulation.

Test Condition:

Test Item	Environmental Conditions	Input Power	Tested By
ERP / EIRP	25 deg. C, 65 % RH	12 Vdc	Thomas Wei
Modulation Characteristics	25 deg. C, 65 % RH	12 Vdc	Getaz Yang
Frequency Stability	25 deg. C, 65 % RH	12 Vdc	Getaz Yang
Occupied Bandwidth	25 deg. C, 65 % RH	12 Vdc	Getaz Yang
Band Edge	25 deg. C, 65 % RH	12 Vdc	Getaz Yang
Peak to Average Ratio	25 deg. C, 65 % RH	12 Vdc	Getaz Yang
Conducted Emission	25 deg. C, 65 % RH	12 Vdc	Getaz Yang
Radiated Emission	25 deg. C, 65 % RH	12 Vdc	Thomas Wei

3.4 EUT Operating Conditions

The EUT makes a call to the communication simulator. The communication simulator station system controlled a EUT to export maximum output power under transmission mode and specific channel frequency

3.5 General Description of Applied Standards

The EUT is a RF Product. According to the specifications of the manufacturer, it must comply with the requirements of the following standards:

FCC 47 CFR Part 2

FCC 47 CFR Part 27

KDB 971168 D01 Power Meas License Digital Systems v03r01

ANSI/TIA/EIA-603-E 2016

ANSI 63.26-2015

Note: All test items have been performed and recorded as per the above standards.

4 Test Types and Results

4.1 Output Power Measurement

4.1.1 Limits of Output Power Measurement

Fixed, mobile, and portable (hand-held) stations operating in the 1710–1755 MHz band and mobile and portable stations operating in the 1695-1710 MHz and 1755-1780 MHz bands are limited to 1 watt EIRP.

Portable stations (hand-held devices) operating in the 746-757 MHz, 776-788 MHz and 805-806 MHz band are limited to 3 watts ERP

Portable stations (hand-held device) operating in the 600 MHz uplink band and the 698-746 MHz band, and fixed and mobile stations in the 600 MHz uplink band are limited to 3 watts ERP.

4.1.2 Test Procedures

EIRP / ERP Measurement:

- a. All measurements were done at low, middle and high operational frequency range. RBW and VBW is 10 MHz for LTE mode.
- b. Substitution method is used for E.I.R.P measurement. In the semi-anechoic chamber, EUT placed on the 0.8 m (below or equal 1 GHz) and/or 1.5 m (above 1 GHz) height of Turn Table, rotated the table around 360 degrees to search the maximum radiation power and receiver antenna shall be rotated vertical and horizontal polarization and moved height from 1 m to 4 m to find the maximum polar radiated power. The “Read Value” is the spectrum reading the maximum power value.
- c. The substitution horn antenna is substituted for EUT at the same position and signals generator export the CW signal to the substitution antenna via a tx cable. Rotated the Turn Table and moved receiving antenna to find the maximum radiation power. Adjust output power level of S.G to get a Value of spectrum reading equal to “Read Value” of step b. Record the power level of S.G.
- d. $EIRP = \text{Output power level of S.G} - \text{TX cable loss} + \text{Antenna gain of substitution horn}$. E.R.P power can be calculated form E.I.R.P power by subtracting the gain of dipole, $E.R.P \text{ power} = E.I.R.P \text{ power} - 2.15 \text{ dB}$.

Conducted Power Measurement:

- a. The EUT was set up for the maximum power with LTE link data modulation and link up with simulator.
- b. Set the EUT to transmit under low, middle and high channel and record the power level shown on simulator.

4.1.3 Test Setup

EIRP / ERP Measurement:

<Radiated Emission below or equal 1 GHz>

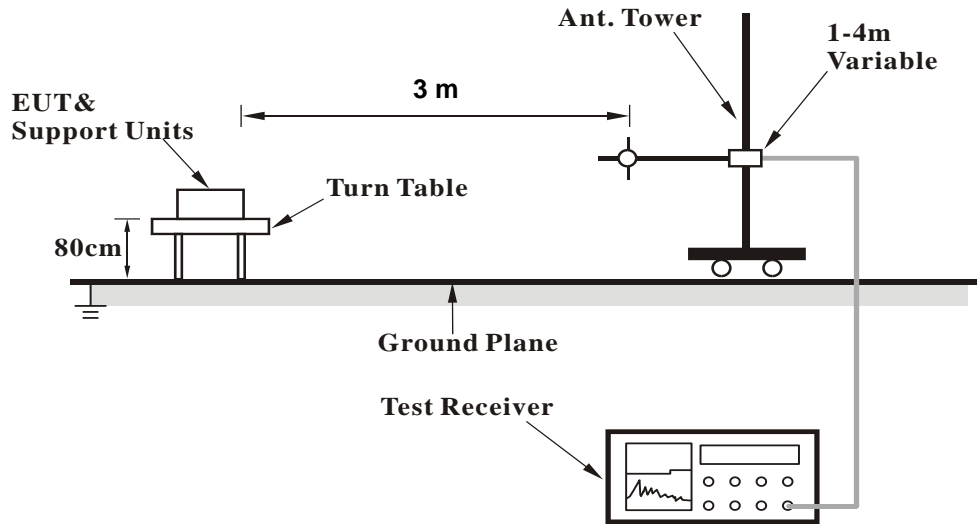

<Radiated Emission above 1 GHz>

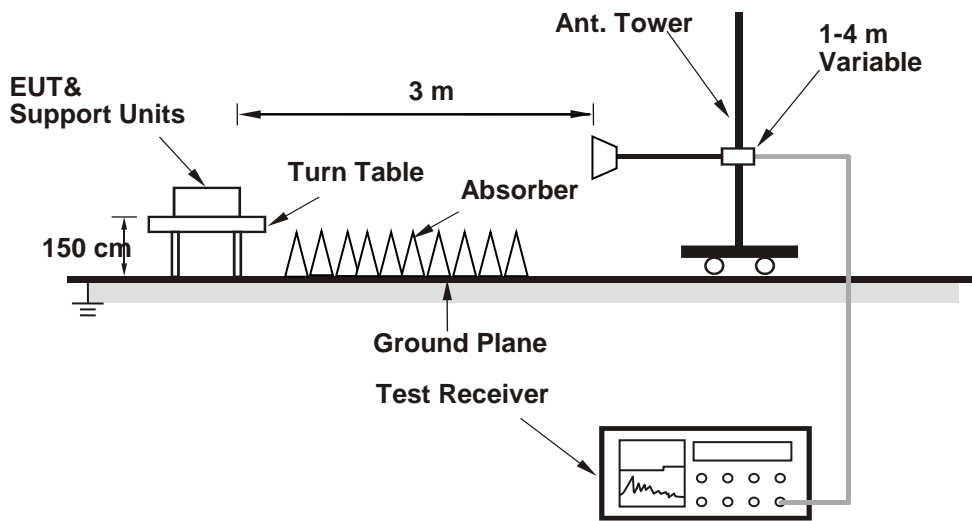

For the actual test configuration, please refer to the attached file (Test Setup Photo).

Conducted Power Measurement:



4.1.4 Test Results

Conducted Output Power (dBm)

eMTC	Band 4	Region(s):	FCC	Power:	Class 3	23	Tolerance:	2.7
------	--------	------------	-----	--------	---------	----	------------	-----

maximum:	23.75
----------	-------

BW(MHz):	1.4
----------	-----

Test Frequency ID	N _{UL}	Frequency of Uplink [MHz]	Test Configuration Initial of Power				EUT	
			Modulation	RB Size	RB Offset	Narrowband Index	Cell power (dBm/15kHz)	power (dBm)
Low Range	19957	1710.7	QPSK	1	0	0	-85	23.41
			QPSK	1	5	0	-85	23.27
			QPSK	3	3	0	-85	22.23
			QPSK	6	0	0	-85	21.19
			16QAM	1	0	0	-85	22.18
			16QAM	1	5	0	-85	22.3
			16QAM	3	0	0	-85	21.66
Mid Range	20175	1732.5	QPSK	1	0	0	-85	23.39
			QPSK	1	5	0	-85	23.71
			QPSK	3	3	0	-85	22.37
			QPSK	6	0	0	-85	21.2
			16QAM	1	0	0	-85	22.85
			16QAM	1	5	0	-85	22.36
			16QAM	3	0	0	-85	21.82
High Range	20393	1754.3	QPSK	1	0	0	-85	23.25
			QPSK	1	5	0	-85	23.15
			QPSK	3	3	0	-85	22.09
			QPSK	6	0	0	-85	21.06
			16QAM	1	0	0	-85	22.06
			16QAM	1	5	0	-85	22.17
			16QAM	3	0	0	-85	21.62
16QAM	5	0	0	-85	21.34			

BW(MHz):	3
----------	---

Test Frequency ID	N _{UL}	Frequency of Uplink [MHz]	Test Configuration Initial of Power				EUT	
			Modulation	RB Size	RB Offset	Narrowband Index	Cell power (dBm/15kHz)	power (dBm)
Low Range	19965	1711.5	QPSK	1	0	0	-85	23.31
			QPSK	1	5	0	-85	23.11
			QPSK	1	0	1	-85	23.15
			QPSK	1	5	1	-85	23.13

			QPSK	3	3	0	-85	22.29
			QPSK	3	3	1	-85	22.07
			QPSK	6	0	0	-85	21.24
			QPSK	6	0	1	-85	21.15
			16QAM	1	0	0	-85	22.31
			16QAM	1	5	0	-85	22.69
			16QAM	1	0	1	-85	22.64
			16QAM	1	5	1	-85	22.41
			16QAM	3	0	0	-85	21.53
			16QAM	3	3	1	-85	21.71
			16QAM	5	0	0	-85	21.65
			16QAM	5	0	1	-85	21.46
Mid Range	20175	1732.5	QPSK	1	0	0	-85	23.36
			QPSK	1	5	0	-85	23.27
			QPSK	1	0	1	-85	23.41
			QPSK	1	5	1	-85	23.36
			QPSK	3	3	0	-85	22.39
			QPSK	3	3	1	-85	22.23
			QPSK	6	0	0	-85	21.29
			QPSK	6	0	1	-85	21.35
			16QAM	1	0	0	-85	22.56
			16QAM	1	5	0	-85	22.79
			16QAM	1	0	1	-85	22.62
			16QAM	1	5	1	-85	22.41
			16QAM	3	0	0	-85	21.8
			16QAM	3	3	1	-85	21.67
			16QAM	5	0	0	-85	21.74
High Range	20385	1753.5	QPSK	1	0	0	-85	23.1
			QPSK	1	5	0	-85	23.12
			QPSK	1	0	1	-85	22.96
			QPSK	1	5	1	-85	23.18
			QPSK	3	3	0	-85	22.06
			QPSK	3	3	1	-85	22.02
			QPSK	6	0	0	-85	21.11
			QPSK	6	0	1	-85	20.98
			16QAM	1	0	0	-85	22.17
			16QAM	1	5	0	-85	21.42
			16QAM	1	0	1	-85	23.09
			16QAM	1	5	1	-85	23.19
			16QAM	3	0	0	-85	21.39

			16QAM	3	3	1	-85	22.08
			16QAM	5	0	0	-85	21.42
			16QAM	5	0	1	-85	22.16

BW(MHz): 5

Test Frequency ID	N _{UL}	Frequency of Uplink [MHz]	Test Configuration Initial of Power				EUT	
			Modulation	RB Size	RB Offset	Narrowband Index	Cell power (dBm/15kHz)	power (dBm)
Low Range	19975	1712.5	QPSK	1	0	0	-85	23.2
			QPSK	1	5	0	-85	23.26
			QPSK	1	0	1	-85	23.21
			QPSK	1	5	1	-85	23.23
			QPSK	1	0	3	-85	23.15
			QPSK	1	5	3	-85	23.23
			QPSK	3	0	0	-85	22.26
			QPSK	3	3	3	-85	22.22
			QPSK	6	0	0	-85	22.23
			QPSK	6	0	1	-85	22.15
			QPSK	6	0	3	-85	22.19
			16QAM	1	0	0	-85	23.53
			16QAM	1	5	0	-85	22.96
			16QAM	1	0	1	-85	23.27
			16QAM	1	5	1	-85	23.27
			16QAM	1	0	3	-85	23.31
			16QAM	1	5	3	-85	23.69
			16QAM	3	0	0	-85	22.64
			16QAM	3	3	3	-85	22.65
			16QAM	5	0	0	-85	21.58
16QAM	5	0	1	-85	21.53			
16QAM	5	0	3	-85	21.51			
Mid Range	20175	1732.5	QPSK	1	0	0	-85	23.25
			QPSK	1	5	0	-85	23.35
			QPSK	1	0	1	-85	23.34
			QPSK	1	5	1	-85	23.41
			QPSK	1	0	3	-85	23.44
			QPSK	1	5	3	-85	23.39
			QPSK	3	0	0	-85	22.27
			QPSK	3	3	3	-85	22.4
			QPSK	6	0	0	-85	22.25
			QPSK	6	0	1	-85	22.37
			QPSK	6	0	3	-85	22.33

			16QAM	1	0	0	-85	23.02
			16QAM	1	5	0	-85	23.57
			16QAM	1	0	1	-85	23.68
			16QAM	1	5	1	-85	23.68
			16QAM	1	0	3	-85	23.48
			16QAM	1	5	3	-85	23.51
			16QAM	3	0	0	-85	22.66
			16QAM	3	3	3	-85	22.79
			16QAM	5	0	0	-85	21.77
			16QAM	5	0	1	-85	21.77
			16QAM	5	0	3	-85	21.57
High Range	20375	1752.5	QPSK	1	0	0	-85	23.08
			QPSK	1	5	0	-85	23.19
			QPSK	1	0	1	-85	23.13
			QPSK	1	5	1	-85	23.25
			QPSK	1	0	3	-85	23.23
			QPSK	1	5	3	-85	23.21
			QPSK	3	0	0	-85	22.26
			QPSK	3	3	3	-85	22.19
			QPSK	6	0	0	-85	22.25
			QPSK	6	0	1	-85	22.24
			QPSK	6	0	3	-85	22.13
			16QAM	1	0	0	-85	23.33
			16QAM	1	5	0	-85	23.4
			16QAM	1	0	1	-85	23.29
			16QAM	1	5	1	-85	23.31
			16QAM	1	0	3	-85	23.48
			16QAM	1	5	3	-85	23.52
			16QAM	3	0	0	-85	22.61
			16QAM	3	3	3	-85	22.71
			16QAM	5	0	0	-85	21.74
16QAM	5	0	1	-85	21.69			
16QAM	5	0	3	-85	21.36			

BW(MHz):	10
----------	----

Test Frequency ID	N _{UL}	Frequency of Uplink [MHz]	Test Configuration Initial of Power				EUT	
			Modulation	RB Size	RB Offset	Narrowband Index	Cell power (dBm/15kHz)	power (dBm)
Low Range	20000	1715	QPSK	1	0	0	-85	23.15

			QPSK	1	5	0	-85	23.21
			QPSK	1	0	3	-85	22.97
			QPSK	1	5	3	-85	23.12
			QPSK	1	0	7	-85	23.03
			QPSK	1	5	7	-85	23.05
			QPSK	4	0	0	-85	23.29
			QPSK	4	2	7	-85	23.13
			QPSK	6	0	0	-85	22.31
			QPSK	6	0	7	-85	22.29
			16QAM	1	0	0	-85	23.21
			16QAM	1	5	0	-85	23.28
			16QAM	1	0	3	-85	23.24
			16QAM	1	5	3	-85	23.14
			16QAM	1	0	7	-85	23.54
			16QAM	1	5	7	-85	23.54
			16QAM	4	2	0	-85	22.34
			16QAM	4	2	7	-85	22.35
			16QAM	5	0	0	-85	22.68
			16QAM	5	0	7	-85	22.37
			QPSK	1	0	0	-85	23.13
			QPSK	1	5	0	-85	23.11
			QPSK	1	0	3	-85	23.15
			QPSK	1	5	3	-85	23.23
			QPSK	1	0	7	-85	22.89
			QPSK	1	5	7	-85	23.02
			QPSK	4	0	0	-85	23.23
			QPSK	4	2	7	-85	23.12
			QPSK	6	0	0	-85	22.29
			QPSK	6	0	7	-85	22.21
			16QAM	1	0	0	-85	23.47
			16QAM	1	5	0	-85	23.05
			16QAM	1	0	3	-85	23.47
			16QAM	1	5	3	-85	23.62
			16QAM	1	0	7	-85	23.2
			16QAM	1	5	7	-85	23.09
			16QAM	4	2	0	-85	22.34
			16QAM	4	2	7	-85	22.31
			16QAM	5	0	0	-85	22.44
			16QAM	5	0	7	-85	22.23
High Range	20350	1750	QPSK	1	0	0	-85	23.17
			QPSK	1	5	0	-85	23.11

			QPSK	1	5	7	-85	22.81
			QPSK	1	0	3	-85	23.18
			QPSK	1	5	3	-85	23.24
			QPSK	1	0	7	-85	23.02
			QPSK	4	0	0	-85	23.13
			QPSK	4	2	7	-85	23.12
			QPSK	6	0	0	-85	22.07
			QPSK	6	0	7	-85	21.22
			16QAM	1	0	0	-85	22.96
			16QAM	1	5	0	-85	23.07
			16QAM	1	0	3	-85	23.22
			16QAM	1	5	3	-85	23.35
			16QAM	1	0	7	-85	23.26
			16QAM	1	5	7	-85	23.48
			16QAM	4	2	0	-85	23.05
			16QAM	4	2	7	-85	22.15
			16QAM	5	0	0	-85	22.13
			16QAM	5	0	7	-85	22.04

BW(MHz): 15

Test Frequency ID	N _{UL}	Frequency of Uplink [MHz]	Test Configuration Initial of Power				EUT	
			Modulation	RB Size	RB Offset	Narrowband Index	Cell power (dBm/15kHz)	power (dBm)
Low Range	20025	1717.5	QPSK	1	0	0	-85	23.03
			QPSK	1	5	0	-85	23.04
			QPSK	1	0	5	-85	23.14
			QPSK	1	5	5	-85	23.18
			QPSK	1	0	11	-85	23.27
			QPSK	1	5	11	-85	23.18
			QPSK	3	0	0	-85	23.29
			QPSK	3	3	11	-85	23.21
			QPSK	6	0	0	-85	23.12
			QPSK	6	0	11	-85	23.16
			16QAM	1	0	0	-85	23.26
			16QAM	1	5	0	-85	23.17
			16QAM	1	0	5	-85	23.08
			16QAM	1	5	5	-85	23.06
			16QAM	1	0	11	-85	23.15
			16QAM	1	5	11	-85	23.13

			16QAM	3	0	0	-85	23.46
			16QAM	3	3	11	-85	23.2
			16QAM	5	0	0	-85	23.42
			16QAM	5	0	11	-85	23.17
Mid Range	20175	1732.5	QPSK	1	0	0	-85	23.11
			QPSK	1	5	0	-85	23.12
			QPSK	1	0	5	-85	23.12
			QPSK	1	5	5	-85	23.14
			QPSK	1	0	11	-85	23.08
			QPSK	1	5	11	-85	23.16
			QPSK	3	0	0	-85	23.15
			QPSK	3	3	11	-85	23.21
			QPSK	6	0	0	-85	23.25
			QPSK	6	0	11	-85	23.16
			16QAM	1	0	0	-85	23.53
			16QAM	1	5	0	-85	22.97
			16QAM	1	0	5	-85	23.44
			16QAM	1	5	5	-85	23.45
			16QAM	1	0	11	-85	23.06
			16QAM	1	5	11	-85	23.09
			16QAM	3	0	0	-85	23.21
			16QAM	3	3	11	-85	23.26
			16QAM	5	0	0	-85	23.19
			16QAM	5	0	11	-85	23.11
High Range	20325	1747.5	QPSK	1	0	0	-85	23.06
			QPSK	1	5	0	-85	23.24
			QPSK	1	0	5	-85	23.15
			QPSK	1	5	5	-85	23.13
			QPSK	1	0	11	-85	23.05
			QPSK	1	5	11	-85	23.03
			QPSK	3	0	0	-85	23.03
			QPSK	3	3	11	-85	23.07
			QPSK	6	0	0	-85	23.05
			QPSK	6	0	11	-85	23.03
			16QAM	1	0	0	-85	23.02
			16QAM	1	5	0	-85	23.11
			16QAM	1	0	5	-85	23.16
			16QAM	1	5	5	-85	23.22
			16QAM	1	0	11	-85	23.28
			16QAM	1	5	11	-85	23.34

			16QAM	3	0	0	-85	23.27
			16QAM	3	3	11	-85	23.29
			16QAM	5	0	0	-85	23.16
			16QAM	5	0	11	-85	23.11

BW(MHz): 20

Test Frequency ID	N _{UL}	Frequency of Uplink [MHz]	Test Configuration Initial of Power				EUT	
			Modulation	RB Size	RB Offset	Narrowband Index	Cell power (dBm/15kHz)	power (dBm)
Low Range	20050	1720	QPSK	1	0	0	-85	23.19
			QPSK	1	5	0	-85	23.25
			QPSK	1	0	7	-85	23.04
			QPSK	1	5	7	-85	23.17
			QPSK	1	0	15	-85	23.13
			QPSK	1	5	15	-85	23.14
			QPSK	3	0	0	-85	23.13
			QPSK	3	3	15	-85	23.13
			QPSK	6	0	0	-85	23.11
			QPSK	6	0	15	-85	23.33
			16QAM	1	0	0	-85	22.81
			16QAM	1	5	0	-85	22.78
			16QAM	1	0	7	-85	23.14
			16QAM	1	5	7	-85	23.34
			16QAM	1	0	15	-85	23.23
			16QAM	1	5	15	-85	23.43
			16QAM	3	0	0	-85	23.25
			16QAM	3	3	15	-85	23.01
			16QAM	5	0	0	-85	23.44
			16QAM	5	0	15	-85	23.34
Mid Range	20175	1732.5	QPSK	1	0	0	-85	23.27
			QPSK	1	5	0	-85	23.33
			QPSK	1	0	7	-85	23.11
			QPSK	1	5	7	-85	23.27
			QPSK	1	0	15	-85	23.16
			QPSK	1	5	15	-85	23.21
			QPSK	3	0	0	-85	23.24
			QPSK	3	3	15	-85	23.14
			QPSK	6	0	0	-85	23.22
			QPSK	6	0	15	-85	23.15

			16QAM	1	0	0	-85	23.75
			16QAM	1	5	0	-85	23.69
			16QAM	1	0	7	-85	23.24
			16QAM	1	5	7	-85	23.28
			16QAM	1	0	15	-85	23.27
			16QAM	1	5	15	-85	23.23
			16QAM	3	0	0	-85	23.21
			16QAM	3	3	15	-85	23.36
			16QAM	5	0	0	-85	23.44
			16QAM	5	0	15	-85	23.31
			QPSK	1	0	0	-85	23.07
			QPSK	1	5	0	-85	23.23
			QPSK	1	0	7	-85	23.08
			QPSK	1	5	7	-85	23.01
			QPSK	1	0	15	-85	22.99
			QPSK	1	5	15	-85	23.23
			QPSK	3	0	0	-85	23.11
			QPSK	3	3	15	-85	22.98
			QPSK	6	0	0	-85	23.05
			QPSK	6	0	15	-85	23.05
			16QAM	1	0	0	-85	23.39
			16QAM	1	5	0	-85	23.25
			16QAM	1	0	7	-85	23.09
			16QAM	1	5	7	-85	23.05
			16QAM	1	0	15	-85	23.16
			16QAM	1	5	15	-85	23.18
			16QAM	3	0	0	-85	23.12
			16QAM	3	3	15	-85	23.21
			16QAM	5	0	0	-85	23.35
			16QAM	5	0	15	-85	23.27
High Range	20300	1745						

eMTC	Band 12	Region(s):	FCC	Power:	Class 3	23	Tolerance:	2.7
------	---------	------------	-----	--------	---------	----	------------	-----

maximum:	23.89
----------	-------

BW(MHz):	1.4
----------	-----

Test Frequency ID	N _{UL}	Frequency of Uplink [MHz]	Test Configuration Initial of Power				EUT	
			Modulation	RB Size	RB Offset	Narrowband Index	Cell power (dBm/15kHz)	power (dBm)
Low Range	23017	699.7	QPSK	1	0	0	-85	23.64
			QPSK	1	5	0	-85	23.57
			QPSK	3	3	0	-85	22.19
			QPSK	6	0	0	-85	21.3
			16QAM	1	0	0	-85	22.08
			16QAM	1	5	0	-85	22.06
			16QAM	3	0	0	-85	21.79
			16QAM	5	0	0	-85	21.83
Mid Range	23095	707.5	QPSK	1	0	0	-85	23.68
			QPSK	1	5	0	-85	23.72
			QPSK	3	3	0	-85	22.48
			QPSK	6	0	0	-85	21.36
			16QAM	1	0	0	-85	22.13
			16QAM	1	5	0	-85	22.2
			16QAM	3	0	0	-85	22.01
			16QAM	5	0	0	-85	21.37
High Range	23173	715.3	QPSK	1	0	0	-85	23.64
			QPSK	1	5	0	-85	23.88
			QPSK	3	3	0	-85	22.37
			QPSK	6	0	0	-85	21.37
			16QAM	1	0	0	-85	22.04
			16QAM	1	5	0	-85	22.33
			16QAM	3	0	0	-85	21.9
			16QAM	5	0	0	-85	21.29

BW(MHz):	3
----------	---

Test Frequency ID	N _{UL}	Frequency of Uplink [MHz]	Test Configuration Initial of Power				EUT	
			Modulation	RB Size	RB Offset	Narrowband Index	Cell power (dBm/15kHz)	power (dBm)
Low Range	23025	700.5	QPSK	1	0	0	-85	23.62
			QPSK	1	5	0	-85	23.74
			QPSK	1	0	1	-85	23.54
			QPSK	1	5	1	-85	23.59
			QPSK	3	3	0	-85	22.39
			QPSK	3	3	1	-85	22.46

			QPSK	6	0	0	-85	21.35
			QPSK	6	0	1	-85	21.43
			16QAM	1	0	0	-85	22.55
			16QAM	1	5	0	-85	22.51
			16QAM	1	0	1	-85	22.53
			16QAM	1	5	1	-85	22.57
			16QAM	3	0	0	-85	22
			16QAM	3	3	1	-85	21.87
			16QAM	5	0	0	-85	21.88
			16QAM	5	0	1	-85	21.96
Mid Range	23095	701.5	QPSK	1	0	0	-85	23.52
			QPSK	1	5	0	-85	23.57
			QPSK	1	0	1	-85	23.55
			QPSK	1	5	1	-85	23.5
			QPSK	3	3	0	-85	22.49
			QPSK	3	3	1	-85	22.43
			QPSK	6	0	0	-85	21.41
			QPSK	6	0	1	-85	21.44
			16QAM	1	0	0	-85	22.5
			16QAM	1	5	0	-85	22.56
			16QAM	1	0	1	-85	23.59
			16QAM	1	5	1	-85	23.52
			16QAM	3	0	0	-85	21.51
			16QAM	3	3	1	-85	22.46
			16QAM	5	0	0	-85	21.84
High Range	23165	714.5	QPSK	1	0	0	-85	23.53
			QPSK	1	5	0	-85	23.47
			QPSK	1	0	1	-85	23.43
			QPSK	1	5	1	-85	23.5
			QPSK	3	3	0	-85	22.42
			QPSK	3	3	1	-85	22.49
			QPSK	6	0	0	-85	21.39
			QPSK	6	0	1	-85	21.31
			16QAM	1	0	0	-85	22.53
			16QAM	1	5	0	-85	22.58
			16QAM	1	0	1	-85	22.61
			16QAM	1	5	1	-85	22.53
			16QAM	3	0	0	-85	21.94
			16QAM	3	3	1	-85	21.79
			16QAM	5	0	0	-85	21.26

			16QAM	5	0	1	-85	21.92
--	--	--	-------	---	---	---	-----	-------

BW(MHz): 5

Test Frequency ID	N _{UL}	Frequency of Uplink [MHz]	Test Configuration Initial of Power				EUT	
			Modulation	RB Size	RB Offset	Narrowband Index	Cell power (dBm/15kHz)	power (dBm)
Low Range	23035	701.5	QPSK	1	0	0	-85	23.54
			QPSK	1	5	0	-85	23.49
			QPSK	1	0	1	-85	23.42
			QPSK	1	5	1	-85	23.61
			QPSK	1	0	3	-85	23.46
			QPSK	1	5	3	-85	23.42
			QPSK	3	0	0	-85	22.45
			QPSK	3	3	3	-85	22.35
			QPSK	6	0	0	-85	22.48
			QPSK	6	0	1	-85	22.47
			QPSK	6	0	3	-85	23.56
			16QAM	1	0	0	-85	23.41
			16QAM	1	5	0	-85	23.41
			16QAM	1	0	1	-85	23.56
			16QAM	1	5	1	-85	23.59
			16QAM	1	0	3	-85	23.12
			16QAM	1	5	3	-85	23.44
			16QAM	3	0	0	-85	22.76
			16QAM	3	3	3	-85	22.76
			16QAM	5	0	0	-85	21.77
16QAM	5	0	1	-85	21.81			
16QAM	5	0	3	-85	21.39			
Mid Range	23095	707.5	QPSK	1	0	0	-85	23.32
			QPSK	1	5	0	-85	23.38
			QPSK	1	0	1	-85	23.45
			QPSK	1	5	1	-85	23.43
			QPSK	1	0	3	-85	23.43
			QPSK	1	5	3	-85	23.19
			QPSK	3	0	0	-85	22.33
			QPSK	3	3	3	-85	22.32
			QPSK	6	0	0	-85	22.37
			QPSK	6	0	1	-85	22.48
			QPSK	6	0	3	-85	22.39
			16QAM	1	0	0	-85	23.4
			16QAM	1	5	0	-85	23.41

			16QAM	1	0	1	-85	23.25
			16QAM	1	5	1	-85	23.29
			16QAM	1	0	3	-85	22.76
			16QAM	1	5	3	-85	23.49
			16QAM	3	0	0	-85	22.89
			16QAM	3	3	3	-85	22.84
			16QAM	5	0	0	-85	21.53
			16QAM	5	0	1	-85	21.67
			16QAM	5	0	3	-85	21.39
High Range	23155	713.5	QPSK	1	0	0	-85	23.25
			QPSK	1	5	0	-85	23.22
			QPSK	1	0	1	-85	23.4
			QPSK	1	5	1	-85	23.35
			QPSK	1	0	3	-85	23.44
			QPSK	1	5	3	-85	23.39
			QPSK	3	0	0	-85	22.47
			QPSK	3	3	3	-85	22.39
			QPSK	6	0	0	-85	22.44
			QPSK	6	0	1	-85	22.44
			QPSK	6	0	3	-85	22.47
			16QAM	1	0	0	-85	23.38
			16QAM	1	5	0	-85	23.04
			16QAM	1	0	1	-85	23.47
			16QAM	1	5	1	-85	23.53
			16QAM	1	0	3	-85	23.51
			16QAM	1	5	3	-85	23.32
			16QAM	3	0	0	-85	22.87
			16QAM	3	3	3	-85	22.87
			16QAM	5	0	0	-85	21.69
			16QAM	5	0	1	-85	21.59
16QAM	5	0	3	-85	21.69			

BW(MHz): 10

Test Frequency ID	N _{UL}	Frequency of Uplink [MHz]	Test Configuration Initial of Power				EUT	
			Modulation	RB Size	RB Offset	Narrowband Index	Cell power (dBm/15kHz)	power (dBm)
Low Range	23060	704	QPSK	1	0	0	-85	23.43
			QPSK	1	5	0	-85	23.41
			QPSK	1	0	3	-85	23.4
			QPSK	1	5	3	-85	23.56

			QPSK	1	0	7	-85	23.31
			QPSK	1	5	7	-85	23.27
			QPSK	4	0	0	-85	23.26
			QPSK	4	2	7	-85	23.47
			QPSK	6	0	0	-85	22.47
			QPSK	6	0	7	-85	22.34
			16QAM	1	0	0	-85	23.12
			16QAM	1	5	0	-85	23.26
			16QAM	1	0	3	-85	23.14
			16QAM	1	5	3	-85	23.12
			16QAM	1	0	7	-85	23.32
			16QAM	1	5	7	-85	22.98
			16QAM	4	2	0	-85	22.52
			16QAM	4	2	7	-85	22.53
			16QAM	5	0	0	-85	22.61
			16QAM	5	0	7	-85	22.67
Mid Range	23095	707.5	QPSK	1	0	0	-85	23.36
			QPSK	1	5	0	-85	23.39
			QPSK	1	0	3	-85	23.39
			QPSK	1	5	3	-85	23.19
			QPSK	1	0	7	-85	23.33
			QPSK	1	5	7	-85	23.18
			QPSK	4	0	0	-85	23.37
			QPSK	4	2	7	-85	23.27
			QPSK	6	0	0	-85	22.39
			QPSK	6	0	7	-85	22.44
			16QAM	1	0	0	-85	23.27
			16QAM	1	5	0	-85	23.24
			16QAM	1	0	3	-85	23.1
			16QAM	1	5	3	-85	23.14
			16QAM	1	0	7	-85	23.15
			16QAM	1	5	7	-85	23.12
16QAM	4	2	0	-85	22.66			
16QAM	4	2	7	-85	22.71			
16QAM	5	0	0	-85	22.49			
16QAM	5	0	7	-85	22.69			
High Range	23130	711	QPSK	1	0	0	-85	23.55
			QPSK	1	5	0	-85	23.59
			QPSK	1	5	7	-85	23.19
			QPSK	1	0	3	-85	23.49
			QPSK	1	5	3	-85	23.55

		QPSK	1	0	7	-85	23.38
		QPSK	4	0	0	-85	23.56
		QPSK	4	2	7	-85	23.28
		QPSK	6	0	0	-85	22.49
		QPSK	6	0	7	-85	22.52
		16QAM	1	0	0	-85	23.03
		16QAM	1	5	0	-85	23.14
		16QAM	1	0	3	-85	23.89
		16QAM	1	5	3	-85	23.2
		16QAM	1	0	7	-85	23.12
		16QAM	1	5	7	-85	23.26
		16QAM	4	2	0	-85	22.78
		16QAM	4	2	7	-85	22.81
		16QAM	5	0	0	-85	22.91
		16QAM	5	0	7	-85	22.67

eMTC	Band 13	Region(s):	FCC	Power:	Class 3	23	Tolerance:	2.7
------	---------	------------	-----	--------	---------	----	------------	-----

maximum:	23.95
----------	-------

BW(MHz):	5
----------	---

Test Frequency ID	N _{UL}	Frequency of Uplink [MHz]	Test Configuration Initial of Power				EUT	
			Modulation	RB Size	RB Offset	Narrowband Index	Cell power (dBm/15kHz)	power (dBm)
Low Range	23205	779.5	QPSK	1	0	0	-85	23.4
			QPSK	1	5	0	-85	23.46
			QPSK	1	0	1	-85	23.48
			QPSK	1	5	1	-85	23.66
			QPSK	1	0	3	-85	23.68
			QPSK	1	5	3	-85	23.7
			QPSK	3	0	0	-85	22.51
			QPSK	3	3	3	-85	22.76
			QPSK	6	0	0	-85	22.48
			QPSK	6	0	1	-85	22.6
			QPSK	6	0	3	-85	23.75
			16QAM	1	0	0	-85	23.85
			16QAM	1	5	0	-85	23.8
			16QAM	1	0	1	-85	23.78
			16QAM	1	5	1	-85	23.77
			16QAM	1	0	3	-85	23.76
			16QAM	1	5	3	-85	23.91
			16QAM	3	0	0	-85	22.92
			16QAM	3	3	3	-85	23.08
			16QAM	5	0	0	-85	21.78
16QAM	5	0	1	-85	22.07			
16QAM	5	0	3	-85	21.66			
Mid Range	23230	782	QPSK	1	0	0	-85	23.69
			QPSK	1	5	0	-85	23.51
			QPSK	1	0	1	-85	23.62
			QPSK	1	5	1	-85	23.71
			QPSK	1	0	3	-85	23.25
			QPSK	1	5	3	-85	23.45
			QPSK	3	0	0	-85	22.55
			QPSK	3	3	3	-85	22.57
			QPSK	6	0	0	-85	22.61
			QPSK	6	0	1	-85	22.66
			QPSK	6	0	3	-85	22.49
			16QAM	1	0	0	-85	23.75
			16QAM	1	5	0	-85	23.69

			16QAM	1	0	1	-85	23.59
			16QAM	1	5	1	-85	23.71
			16QAM	1	0	3	-85	23.92
			16QAM	1	5	3	-85	23.73
			16QAM	3	0	0	-85	23.05
			16QAM	3	3	3	-85	23.02
			16QAM	5	0	0	-85	21.58
			16QAM	5	0	1	-85	22.52
			16QAM	5	0	3	-85	21.85
High Range	23255	784.5	QPSK	1	0	0	-85	23.6
			QPSK	1	5	0	-85	23.54
			QPSK	1	0	1	-85	23.46
			QPSK	1	5	1	-85	23.55
			QPSK	1	0	3	-85	23.51
			QPSK	1	5	3	-85	23.54
			QPSK	3	0	0	-85	22.47
			QPSK	3	3	3	-85	22.51
			QPSK	6	0	0	-85	22.54
			QPSK	6	0	1	-85	22.4
			QPSK	6	0	3	-85	22.55
			16QAM	1	0	0	-85	23.68
			16QAM	1	5	0	-85	23.64
			16QAM	1	0	1	-85	23.56
			16QAM	1	5	1	-85	23.57
			16QAM	1	0	3	-85	23.75
			16QAM	1	5	3	-85	23.29
			16QAM	3	0	0	-85	22.99
			16QAM	3	3	3	-85	23.08
			16QAM	5	0	0	-85	21.54
			16QAM	5	0	1	-85	21.74
			16QAM	5	0	3	-85	22.16

BW(MHz): 10

Test Frequency ID	N _{UL}	Frequency of Uplink [MHz]	Test Configuration Initial of Power				EUT	
			Modulation	RB Size	RB Offset	Narrowband Index	Cell power (dBm/15kHz)	power (dBm)
-	23230	782	QPSK	1	0	0	-85	23.53
			QPSK	1	5	0	-85	23.52
			QPSK	1	0	3	-85	23.43

		QPSK	1	5	3	-85	23.48
		QPSK	1	0	7	-85	23.48
		QPSK	1	5	7	-85	23.54
		QPSK	4	0	0	-85	23.57
		QPSK	4	2	7	-85	23.61
		QPSK	6	0	0	-85	22.62
		QPSK	6	0	7	-85	22.63
		16QAM	1	0	0	-85	23.33
		16QAM	1	5	0	-85	23.31
		16QAM	1	0	3	-85	23.61
		16QAM	1	5	3	-85	23.51
		16QAM	1	0	7	-85	23.81
		16QAM	1	5	7	-85	23.95
		16QAM	4	2	0	-85	22.61
		16QAM	4	2	7	-85	22.73
		16QAM	5	0	0	-85	22.81
		16QAM	5	0	7	-85	22.71

ERP Power (dBm)

LTE Band 12							
Channel Bandwidth: 1.4 MHz / QPSK							
Plane	Channel	Frequency (MHz)	Reading (dBm)	Correction Factor (dB)	ERP (dBm)	ERP (mW)	Polarization (H/V)
X	23017	699.7	-8.82	30.36	19.39	86.90	H
	23095	707.5	-8.55	30.17	19.47	88.51	
	23173	715.3	-8.39	30.17	19.63	91.83	
	23017	699.7	-15.74	32.03	14.14	25.94	V
	23095	707.5	-15.55	31.98	14.28	26.79	
	23173	715.3	-15.45	32.06	14.46	27.93	
Channel Bandwidth: 1.4 MHz / 16QAM							
X	23017	699.7	-9.81	30.36	18.40	69.18	H
	23095	707.5	-9.54	30.17	18.48	70.47	
	23173	715.3	-9.38	30.17	18.64	73.11	
	23017	699.7	-16.73	32.03	13.15	20.65	V
	23095	707.5	-16.54	31.98	13.29	21.33	
	23173	715.3	-16.44	32.06	13.47	22.23	

Note: ERP (dBm) = Reading (dBm) + Correction Factor (dB) – 2.15

LTE Band 12							
Channel Bandwidth: 3 MHz / QPSK							
Plane	Channel	Frequency (MHz)	Reading (dBm)	Correction Factor (dB)	ERP (dBm)	ERP (mW)	Polarization (H/V)
X	23025	700.5	-8.37	30.17	19.65	92.26	H
	23095	707.5	-8.29	30.17	19.73	93.97	
	23165	714.5	-8.14	30.18	19.89	97.50	
	23025	700.5	-15.41	31.96	14.40	27.54	V
	23095	707.5	-15.29	31.98	14.54	28.44	
	23165	714.5	-15.16	32.03	14.72	29.65	
Channel Bandwidth: 3 MHz / 16QAM							
X	23025	700.5	-9.39	30.17	18.63	72.95	H
	23095	707.5	-9.31	30.17	18.71	74.30	
	23165	714.5	-9.16	30.18	18.87	77.09	
	23025	700.5	-16.43	31.96	13.38	21.78	V
	23095	707.5	-16.31	31.98	13.52	22.49	
	23165	714.5	-16.18	32.03	13.70	23.44	

Note: ERP (dBm) = Reading (dBm) + Correction Factor (dB) – 2.15

LTE Band 12							
Channel Bandwidth: 5 MHz / QPSK							
Plane	Channel	Frequency (MHz)	Reading (dBm)	Correction Factor (dB)	ERP (dBm)	ERP (mW)	Polarization (H/V)
X	23035	701.5	-8.13	30.17	19.89	97.50	H
	23095	707.5	-8.05	30.17	19.97	99.31	
	23155	713.5	-7.90	30.18	20.13	103.04	
	23035	701.5	-15.17	31.96	14.64	29.11	V
	23095	707.5	-15.05	31.98	14.78	30.06	
	23155	713.5	-14.92	32.03	14.96	31.33	
Channel Bandwidth: 5 MHz / 16QAM							
X	23035	701.5	-9.14	30.17	18.88	77.27	H
	23095	707.5	-9.06	30.17	18.96	78.70	
	23155	713.5	-8.91	30.18	19.12	81.66	
	23035	701.5	-16.18	31.96	13.63	23.07	V
	23095	707.5	-16.06	31.98	13.77	23.82	
	23155	713.5	-15.93	32.03	13.95	24.83	

Note: ERP (dBm) = Reading (dBm) + Correction Factor (dB) – 2.15

LTE Band 12							
Channel Bandwidth: 10 MHz / QPSK							
Plane	Channel	Frequency (MHz)	Reading (dBm)	Correction Factor (dB)	ERP (dBm)	ERP (mW)	Polarization (H/V)
X	23060	704.0	-7.88	30.17	20.14	103.28	H
	23095	707.5	-7.80	30.17	20.22	105.20	
	23130	711.0	-7.65	30.18	20.38	109.14	
	23060	704.0	-14.92	31.96	14.89	30.83	V
	23095	707.5	-14.80	31.98	15.03	31.84	
	23130	711.0	-14.67	32.03	15.21	33.19	
Channel Bandwidth: 10 MHz / 16QAM							
X	23060	704.0	-8.90	30.17	19.12	81.66	H
	23095	707.5	-8.82	30.17	19.20	83.18	
	23130	711.0	-8.67	30.18	19.36	86.30	
	23060	704.0	-15.94	31.96	13.87	24.38	V
	23095	707.5	-15.82	31.98	14.01	25.18	
	23130	711.0	-15.69	32.03	14.19	26.24	

Note: ERP (dBm) = Reading (dBm) + Correction Factor (dB) – 2.15

LTE Band 13							
Channel Bandwidth: 5 MHz / QPSK							
Plane	Channel	Frequency (MHz)	Reading (dBm)	Correction Factor (dB)	ERP (dBm)	ERP (mW)	Polarization (H/V)
X	23205	779.5	-10.44	32.24	19.65	92.26	H
	23230	782.0	-10.05	32.17	19.97	99.31	
	23255	784.5	-10.18	32.11	19.78	95.06	
	23205	779.5	-15.43	32.43	14.85	30.55	V
	23230	782.0	-15.45	32.42	14.82	30.34	
	23255	784.5	-15.42	32.46	14.89	30.83	
Channel Bandwidth: 5 MHz / 16QAM							
X	23205	779.5	-11.57	32.24	18.52	71.12	H
	23230	782.0	-11.23	32.17	18.79	75.68	
	23255	784.5	-11.09	32.11	18.87	77.09	
	23205	779.5	-16.66	32.43	13.62	23.01	V
	23230	782.0	-16.56	32.42	13.71	23.50	
	23255	784.5	-16.55	32.46	13.76	23.77	

Note: ERP (dBm) = Reading (dBm) + Correction Factor (dB) – 2.15

LTE Band 13							
Channel Bandwidth: 10 MHz / QPSK							
Plane	Channel	Frequency (MHz)	Reading (dBm)	Correction Factor (dB)	ERP (dBm)	ERP (mW)	Polarization (H/V)
X	23230	782.0	-9.77	32.17	20.25	105.93	H
	23230	782.0	-15.02	32.42	15.25	33.50	V
Channel Bandwidth: 10 MHz / 16QAM							
X	23230	782.0	-10.90	32.17	19.12	81.66	H
	23230	782.0	-16.15	32.42	14.12	25.82	V

Note: ERP (dBm) = Reading (dBm) + Correction Factor (dB) – 2.15

EIRP Power (dBm)

LTE Band 4							
Channel Bandwidth: 1.4 MHz / QPSK							
Plane	Channel	Frequency (MHz)	Reading (dBm)	Correction Factor (dB)	EIRP (dBm)	EIRP (mW)	Polarization (H/V)
X	19957	1710.7	-13.72	36.45	22.73	187.50	H
	20175	1732.5	-13.77	36.80	23.03	200.91	
	20393	1754.3	-14.37	36.94	22.57	180.72	
	19957	1710.7	-23.18	37.28	14.10	25.70	V
	20175	1732.5	-23.12	37.63	14.51	28.25	
	20393	1754.3	-23.89	37.64	13.75	23.71	
Channel Bandwidth: 1.4 MHz / 16QAM							
X	19957	1710.7	-14.77	36.45	21.68	147.23	H
	20175	1732.5	-14.82	36.80	21.98	157.76	
	20393	1754.3	-15.42	36.94	21.52	141.91	
	19957	1710.7	-24.23	37.28	13.05	20.18	V
	20175	1732.5	-24.17	37.63	13.46	22.18	
	20393	1754.3	-24.94	37.64	12.70	18.62	

Note: EIRP (dBm) = Reading (dBm) + Correction Factor (dB)

LTE Band 4							
Channel Bandwidth: 3 MHz / QPSK							
Plane	Channel	Frequency (MHz)	Reading (dBm)	Correction Factor (dB)	EIRP (dBm)	EIRP (mW)	Polarization (H/V)
X	19965	1711.5	-13.45	36.45	23.00	199.53	H
	20175	1732.5	-13.50	36.80	23.30	213.80	
	20385	1753.5	-14.10	36.94	22.84	192.31	
	19965	1711.5	-22.91	37.28	14.37	27.35	V
	20175	1732.5	-22.85	37.63	14.78	30.06	
	20385	1753.5	-23.62	37.64	14.02	25.23	
Channel Bandwidth: 3 MHz / 16QAM							
X	19965	1711.5	-14.51	36.45	21.94	156.31	H
	20175	1732.5	-14.56	36.80	22.24	167.49	
	20385	1753.5	-15.16	36.94	21.78	150.66	
	19965	1711.5	-23.97	37.28	13.31	21.43	V
	20175	1732.5	-23.91	37.63	13.72	23.55	
	20385	1753.5	-24.68	37.64	12.96	19.77	

Note: EIRP (dBm) = Reading (dBm) + Correction Factor (dB)

LTE Band 4							
Channel Bandwidth: 5 MHz / QPSK							
Plane	Channel	Frequency (MHz)	Reading (dBm)	Correction Factor (dB)	EIRP (dBm)	EIRP (mW)	Polarization (H/V)
X	19975	1712.5	-13.19	36.45	23.26	211.84	H
	20175	1732.5	-13.24	36.80	23.56	226.99	
	20375	1752.5	-13.84	36.94	23.10	204.17	
	19975	1712.5	-22.65	37.28	14.63	29.04	V
	20175	1732.5	-22.59	37.63	15.04	31.92	
	20375	1752.5	-23.36	37.64	14.28	26.79	
Channel Bandwidth: 5 MHz / 16QAM							
X	19975	1712.5	-14.20	36.45	22.25	167.88	H
	20175	1732.5	-14.25	36.80	22.55	179.89	
	20375	1752.5	-14.85	36.94	22.09	161.81	
	19975	1712.5	-23.66	37.28	13.62	23.01	V
	20175	1732.5	-23.60	37.63	14.03	25.29	
	20375	1752.5	-24.37	37.64	13.27	21.23	

Note: EIRP (dBm) = Reading (dBm) + Correction Factor (dB)

LTE Band 4							
Channel Bandwidth: 10 MHz / QPSK							
Plane	Channel	Frequency (MHz)	Reading (dBm)	Correction Factor (dB)	EIRP (dBm)	EIRP (mW)	Polarization (H/V)
X	20000	1715.0	-13.13	36.64	23.51	224.39	H
	20175	1732.5	-12.99	36.80	23.81	240.44	
	20350	1750.0	-13.45	36.80	23.35	216.27	
	20000	1715.0	-22.56	37.44	14.88	30.76	V
	20175	1732.5	-22.34	37.63	15.29	33.81	
	20350	1750.0	-23.11	37.64	14.53	28.38	
Channel Bandwidth: 10 MHz / 16QAM							
X	20000	1715.0	-14.14	36.64	22.50	177.83	H
	20175	1732.5	-14.00	36.80	22.80	190.55	
	20350	1750.0	-14.46	36.80	22.34	171.40	
	20000	1715.0	-23.57	37.44	13.87	24.38	V
	20175	1732.5	-23.35	37.63	14.28	26.79	
	20350	1750.0	-24.12	37.64	13.52	22.49	

Note: EIRP (dBm) = Reading (dBm) + Correction Factor (dB)

LTE Band 4							
Channel Bandwidth: 15 MHz / QPSK							
Plane	Channel	Frequency (MHz)	Reading (dBm)	Correction Factor (dB)	EIRP (dBm)	EIRP (mW)	Polarization (H/V)
X	20025	1717.5	-12.68	36.45	23.77	238.23	H
	20175	1732.5	-12.73	36.80	24.07	255.27	
	20325	1747.5	-13.33	36.94	23.61	229.61	
	20025	1717.5	-22.14	37.28	15.14	32.66	V
	20175	1732.5	-22.08	37.63	15.55	35.89	
	20325	1747.5	-22.85	37.64	14.79	30.13	
Channel Bandwidth: 15 MHz / 16QAM							
X	20025	1717.5	-13.69	36.45	22.76	188.80	H
	20175	1732.5	-13.74	36.80	23.06	202.30	
	20325	1747.5	-14.34	36.94	22.60	181.97	
	20025	1717.5	-23.15	37.28	14.13	25.88	V
	20175	1732.5	-23.09	37.63	14.54	28.44	
	20325	1747.5	-23.86	37.64	13.78	23.88	

Note: EIRP (dBm) = Reading (dBm) + Correction Factor (dB)

LTE Band 4							
Channel Bandwidth: 20 MHz / QPSK							
Plane	Channel	Frequency (MHz)	Reading (dBm)	Correction Factor (dB)	EIRP (dBm)	EIRP (mW)	Polarization (H/V)
X	20050	1720.0	-12.44	36.45	24.01	251.77	H
	20175	1732.5	-12.49	36.80	24.31	269.77	
	20300	1745.0	-13.09	36.94	23.85	242.66	
	20050	1720.0	-21.90	37.28	15.38	34.51	V
	20175	1732.5	-21.84	37.63	15.79	37.93	
	20300	1745.0	-22.61	37.64	15.03	31.84	
Channel Bandwidth: 20 MHz / 16QAM							
X	20050	1720.0	-13.46	36.45	22.99	199.07	H
	20175	1732.5	-13.51	36.80	23.29	213.30	
	20300	1745.0	-14.11	36.94	22.83	191.87	
	20050	1720.0	-22.92	37.28	14.36	27.29	V
	20175	1732.5	-22.86	37.63	14.77	29.99	
	20300	1745.0	-23.63	37.64	14.01	25.18	

Note: EIRP (dBm) = Reading (dBm) + Correction Factor (dB)

4.2 Modulation Characteristics Measurement

4.2.1 Limits of Modulation Characteristics

N/A

4.2.2 Test Setup

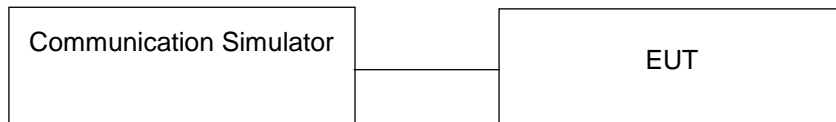

4.2.3 Test Procedure

Connect the EUT to Communication Simulator via the antenna connector. The frequency band is set as EUT supported Modulation and Channels, the EUT output is matched with 50 ohm load, the waveform quality and constellation of the EUT was tested.

4.2.4 Test Results

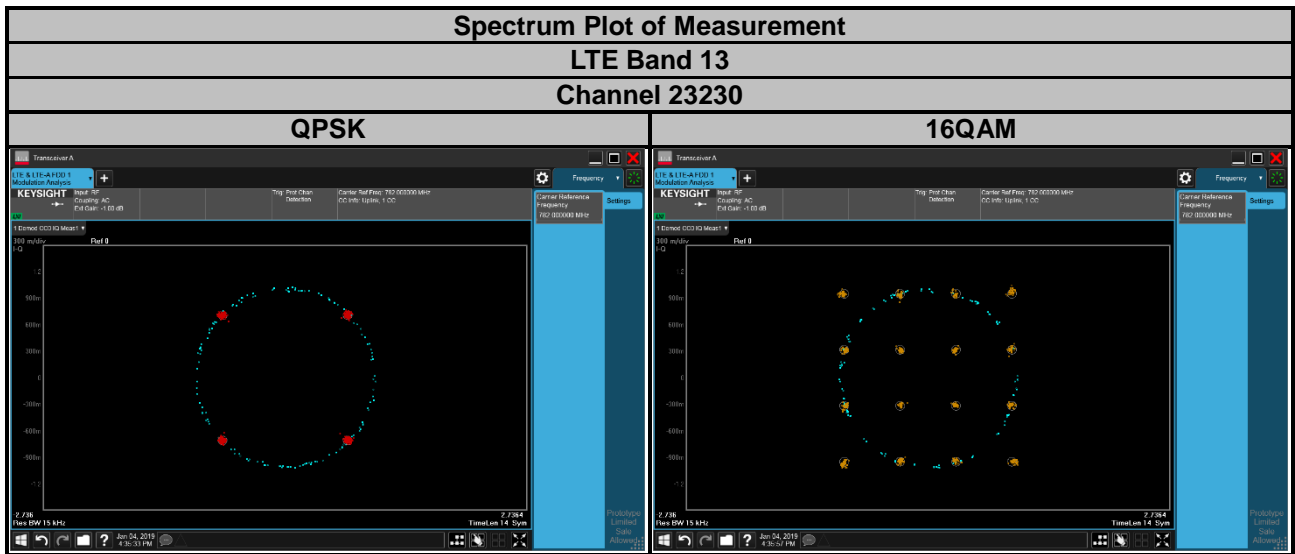
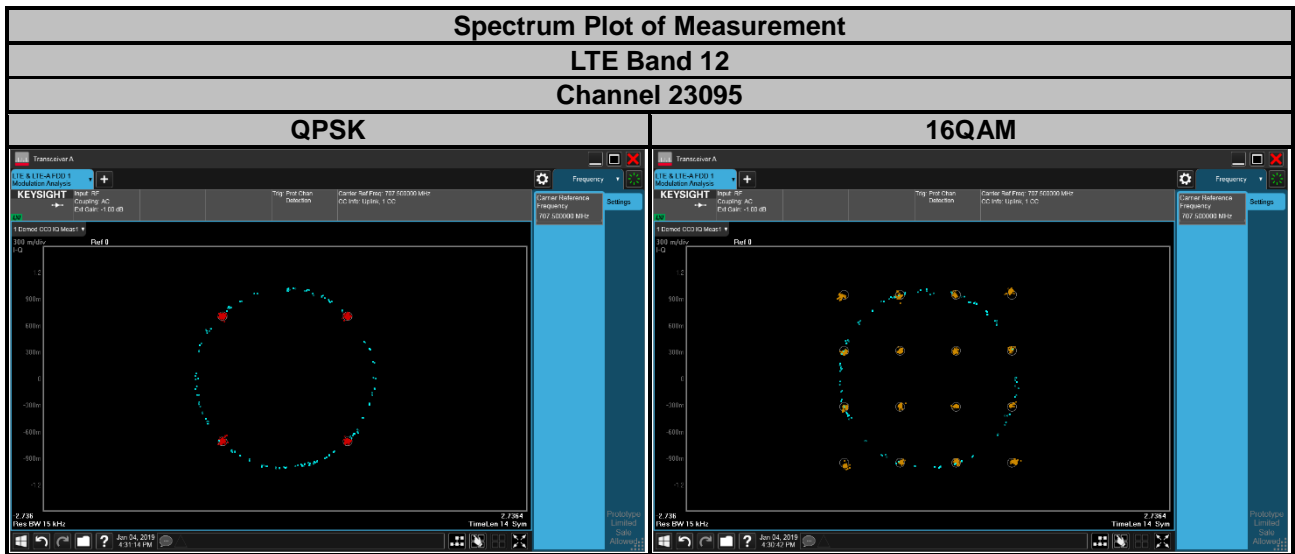
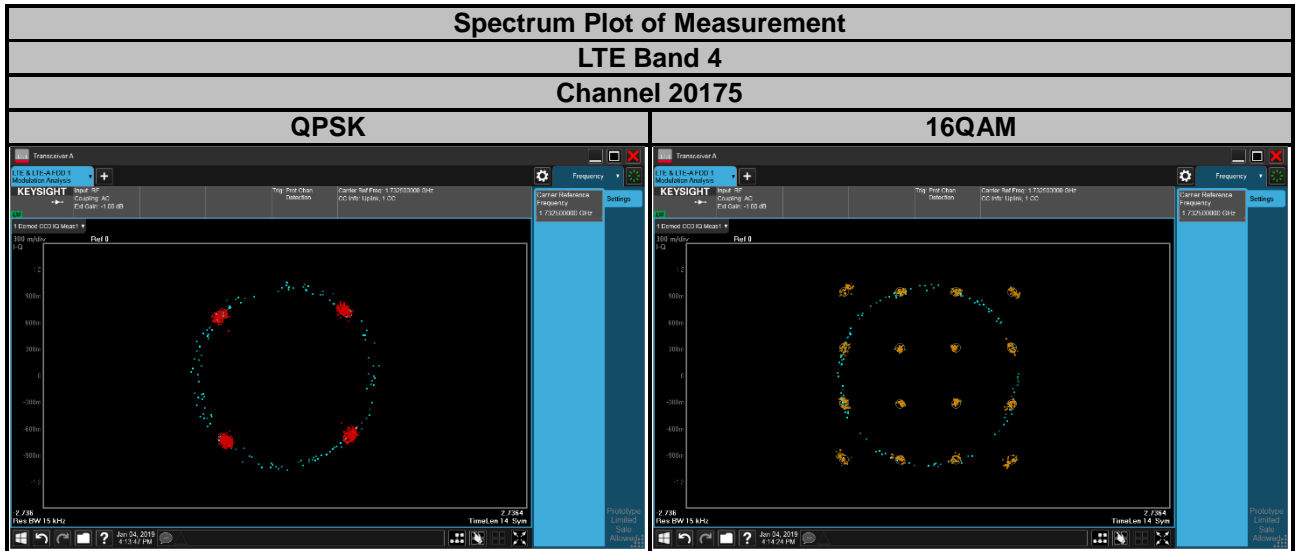

4.3 Frequency Stability Measurement

4.3.1 Limits of Frequency Stability Measurement

The frequency stability shall be sufficient to ensure that the fundamental emissions stay within the authorized bands of operation.

4.3.2 Test Procedure

- Device is placed at the oven room. The oven room could control the temperatures and humidity. Power warm up is at least 15 min and power applied should perform before recording frequency error.
- EUT is connected the external power supply to control the DC input power. The test voltage range is from minimum to maximum working voltage. Each step shall be record the frequency error rate.
- The temperature range step is 10 degrees in this test items. All temperature levels shall be hold the ± 0.5 °C during the measurement testing. The each temperature step shall be at least 0.5 hours, consider the EUT could be test under the stability condition.

Note: The frequency error was recorded frequency error from the communication simulator.

4.3.3 Test Setup

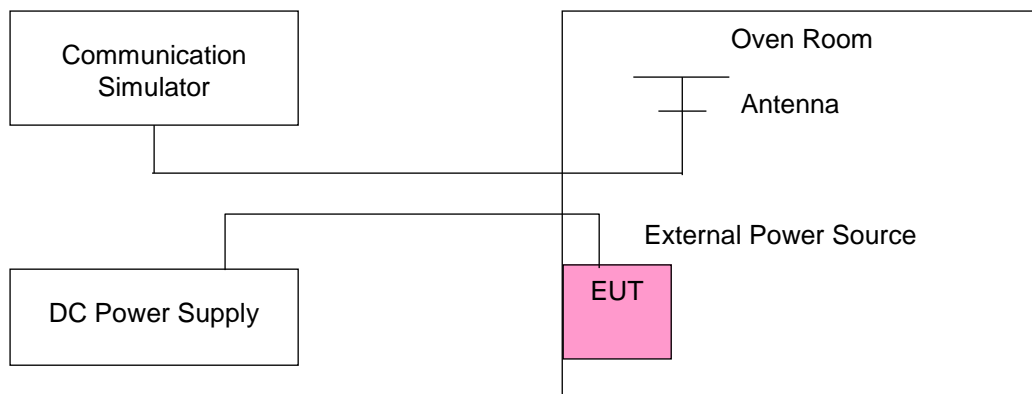

4.3.4 Test Results

Frequency Error vs. Voltage

Voltage (Volts)	LTE Band 4			
	Channel Bandwidth: 1.4 MHz			
	Low Channel		High Channel	
	Frequency (MHz)	Frequency Error (ppm)	Frequency (MHz)	Frequency Error (ppm)
12	1710.700003	0.002	1754.300003	0.002
10.2	1710.700004	0.002	1754.300004	0.002
13.8	1710.700001	0.001	1754.300001	0.001

Note: The fixture defined the normal working voltage of the DC Power Supply is from 10.2 Vdc to 13.8 Vdc.

Frequency Error vs. Temperature

Temp. (°C)	LTE Band 4			
	Channel Bandwidth: 1.4 MHz			
	Low Channel		High Channel	
	Frequency (MHz)	Frequency Error (ppm)	Frequency (MHz)	Frequency Error (ppm)
-30	1710.700002	0.001	1754.300003	0.002
-20	1710.700001	0.001	1754.300004	0.002
-10	1710.700004	0.002	1754.300002	0.001
0	1710.700003	0.002	1754.300004	0.002
10	1710.700002	0.001	1754.300002	0.001
20	1710.700004	0.002	1754.300003	0.002
30	1710.699996	-0.002	1754.299999	-0.001
40	1710.699998	-0.001	1754.299997	-0.002
50	1710.699999	-0.001	1754.299999	-0.001
50	1710.699999	-0.001	1754.299996	-0.002
65	1710.699998	-0.001	1754.299998	-0.001

Frequency Error vs. Voltage

Voltage (Volts)	LTE Band 4			
	Channel Bandwidth: 3 MHz			
	Low Channel		High Channel	
	Frequency (MHz)	Frequency Error (ppm)	Frequency (MHz)	Frequency Error (ppm)
12	1710.700003	0.002	1754.300004	0.002
10.2	1710.700003	0.001	1754.300003	0.001
13.8	1710.700002	0.001	1754.300003	0.002

Note: The fixture defined the normal working voltage of the DC Power Supply is from 10.2 Vdc to 13.8 Vdc.

Frequency Error vs. Temperature

Temp. (°C)	LTE Band 4			
	Channel Bandwidth: 3 MHz			
	Low Channel		High Channel	
	Frequency (MHz)	Frequency Error (ppm)	Frequency (MHz)	Frequency Error (ppm)
-30	1710.700003	0.002	1754.300004	0.002
-20	1710.700004	0.002	1754.300004	0.002
-10	1710.700001	0.001	1754.300001	0.001
0	1710.700002	0.001	1754.300003	0.002
10	1710.700003	0.002	1754.300001	0.001
20	1710.700002	0.001	1754.300004	0.002
30	1710.699999	-0.001	1754.299999	-0.001
40	1710.699997	-0.002	1754.299999	-0.001
50	1710.699999	-0.001	1754.299996	-0.002
50	1710.699998	-0.001	1754.299999	-0.001
65	1710.699999	-0.001	1754.299998	-0.001

Frequency Error vs. Voltage

Voltage (Volts)	LTE Band 4			
	Channel Bandwidth: 5 MHz			
	Low Channel		High Channel	
	Frequency (MHz)	Frequency Error (ppm)	Frequency (MHz)	Frequency Error (ppm)
12	1710.700002	0.001	1754.300002	0.001
10.2	1710.700001	0.001	1754.300003	0.002
13.8	1710.700002	0.001	1754.300004	0.002

Note: The fixture defined the normal working voltage of the DC Power Supply is from 10.2 Vdc to 13.8 Vdc.

Frequency Error vs. Temperature

Temp. (°C)	LTE Band 4			
	Channel Bandwidth: 5 MHz			
	Low Channel		High Channel	
	Frequency (MHz)	Frequency Error (ppm)	Frequency (MHz)	Frequency Error (ppm)
-30	1710.700003	0.002	1754.300003	0.002
-20	1710.700004	0.002	1754.300004	0.002
-10	1710.700003	0.002	1754.300001	0.001
0	1710.700004	0.002	1754.300002	0.001
10	1710.700001	0.001	1754.300004	0.002
20	1710.700002	0.001	1754.300002	0.001
30	1710.699998	-0.001	1754.299998	-0.001
40	1710.699999	-0.001	1754.299998	-0.001
50	1710.699999	-0.001	1754.299996	-0.002
50	1710.699997	-0.002	1754.299998	-0.001
65	1710.699998	-0.001	1754.299997	-0.001

Frequency Error vs. Voltage

Voltage (Volts)	LTE Band 4			
	Channel Bandwidth: 10 MHz			
	Low Channel		High Channel	
	Frequency (MHz)	Frequency Error (ppm)	Frequency (MHz)	Frequency Error (ppm)
12	1710.700004	0.002	1754.300002	0.001
10.2	1710.700002	0.001	1754.300001	0.001
13.8	1710.700003	0.002	1754.300001	0.001

Note: The fixture defined the normal working voltage of the DC Power Supply is from 10.2 Vdc to 13.8 Vdc.

Frequency Error vs. Temperature

Temp. (°C)	LTE Band 4			
	Channel Bandwidth: 10 MHz			
	Low Channel		High Channel	
	Frequency (MHz)	Frequency Error (ppm)	Frequency (MHz)	Frequency Error (ppm)
-30	1710.700003	0.002	1754.300003	0.002
-20	1710.700002	0.001	1754.300001	0.001
-10	1710.700002	0.001	1754.300004	0.002
0	1710.700002	0.001	1754.300002	0.001
10	1710.700004	0.002	1754.300002	0.001
20	1710.700002	0.001	1754.300002	0.001
30	1710.699998	-0.001	1754.299997	-0.002
40	1710.699999	-0.001	1754.299997	-0.002
50	1710.699999	-0.001	1754.299996	-0.002
50	1710.699998	-0.001	1754.299996	-0.002
65	1710.699997	-0.002	1754.299999	-0.001

Frequency Error vs. Voltage

Voltage (Volts)	LTE Band 4			
	Channel Bandwidth: 15 MHz			
	Low Channel		High Channel	
	Frequency (MHz)	Frequency Error (ppm)	Frequency (MHz)	Frequency Error (ppm)
12	1710.700003	0.002	1754.300001	0.001
10.2	1710.700001	0.001	1754.300001	0.001
13.8	1710.700004	0.002	1754.300003	0.002

Note: The fixture defined the normal working voltage of the DC Power Supply is from 10.2 Vdc to 13.8 Vdc.

Frequency Error vs. Temperature

Temp. (°C)	LTE Band 4			
	Channel Bandwidth: 15 MHz			
	Low Channel		High Channel	
	Frequency (MHz)	Frequency Error (ppm)	Frequency (MHz)	Frequency Error (ppm)
-30	1710.700003	0.001	1754.300003	0.002
-20	1710.700003	0.002	1754.300003	0.002
-10	1710.700002	0.001	1754.300003	0.002
0	1710.700001	0.001	1754.300003	0.002
10	1710.700002	0.001	1754.300003	0.002
20	1710.700002	0.001	1754.300002	0.001
30	1710.699997	-0.002	1754.299996	-0.002
40	1710.699996	-0.002	1754.299996	-0.002
50	1710.699998	-0.001	1754.299998	-0.001
50	1710.699998	-0.001	1754.299998	-0.001
65	1710.699999	-0.001	1754.299998	-0.001

Frequency Error vs. Voltage

Voltage (Volts)	LTE Band 4			
	Channel Bandwidth: 20 MHz			
	Low Channel		High Channel	
	Frequency (MHz)	Frequency Error (ppm)	Frequency (MHz)	Frequency Error (ppm)
12	1710.700002	0.001	1754.300002	0.001
10.2	1710.700004	0.002	1754.300004	0.002
13.8	1710.700002	0.001	1754.300004	0.002

Note: The fixture defined the normal working voltage of the DC Power Supply is from 10.2 Vdc to 13.8 Vdc.

Frequency Error vs. Temperature

Temp. (°C)	LTE Band 4			
	Channel Bandwidth: 20 MHz			
	Low Channel		High Channel	
	Frequency (MHz)	Frequency Error (ppm)	Frequency (MHz)	Frequency Error (ppm)
-30	1710.700003	0.002	1754.300003	0.002
-20	1710.700004	0.002	1754.300003	0.002
-10	1710.700004	0.002	1754.300004	0.002
0	1710.700001	0.001	1754.300002	0.001
10	1710.700002	0.001	1754.300004	0.002
20	1710.700002	0.001	1754.300003	0.002
30	1710.699997	-0.002	1754.299997	-0.002
40	1710.699998	-0.001	1754.299997	-0.002
50	1710.699998	-0.001	1754.299999	-0.001
50	1710.699999	-0.001	1754.299996	-0.002
65	1710.699998	-0.001	1754.299998	-0.001

Frequency Error vs. Voltage

Voltage (Volts)	LTE Band 12			
	Channel Bandwidth: 1.4 MHz			
	Low Channel		High Channel	
	Frequency (MHz)	Frequency Error (ppm)	Frequency (MHz)	Frequency Error (ppm)
12	699.700003	0.004	715.300002	0.003
10.2	699.700003	0.004	715.300003	0.004
13.8	699.700004	0.006	715.300002	0.003

Note: The fixture defined the normal working voltage of the DC Power Supply is from 10.2 Vdc to 13.8 Vdc.

Frequency Error vs. Temperature

Temp. (°C)	LTE Band 12			
	Channel Bandwidth: 1.4 MHz			
	Low Channel		High Channel	
	Frequency (MHz)	Frequency Error (ppm)	Frequency (MHz)	Frequency Error (ppm)
-30	699.700002	0.003	715.300003	0.005
-20	699.700003	0.004	715.300004	0.005
-10	699.700002	0.002	715.300002	0.003
0	699.700004	0.005	715.300004	0.005
10	699.700003	0.004	715.300002	0.002
20	699.700002	0.002	715.300002	0.002
30	699.699998	-0.004	715.299997	-0.004
40	699.699997	-0.005	715.299998	-0.003
50	699.699999	-0.002	715.299999	-0.002
50	699.699999	-0.002	715.299996	-0.005
65	699.699997	-0.005	715.299998	-0.003

Frequency Error vs. Voltage

Voltage (Volts)	LTE Band 12			
	Channel Bandwidth: 3 MHz			
	Low Channel		High Channel	
	Frequency (MHz)	Frequency Error (ppm)	Frequency (MHz)	Frequency Error (ppm)
12	699.700003	0.005	715.300001	0.002
10.2	699.700004	0.006	715.300001	0.002
13.8	699.700003	0.004	715.300003	0.004

Note: The fixture defined the normal working voltage of the DC Power Supply is from 10.2 Vdc to 13.8 Vdc.

Frequency Error vs. Temperature

Temp. (°C)	LTE Band 12			
	Channel Bandwidth: 3 MHz			
	Low Channel		High Channel	
	Frequency (MHz)	Frequency Error (ppm)	Frequency (MHz)	Frequency Error (ppm)
-30	699.700004	0.005	715.300004	0.006
-20	699.700003	0.005	715.300003	0.004
-10	699.700004	0.005	715.300002	0.003
0	699.700004	0.006	715.300003	0.005
10	699.700002	0.002	715.300004	0.005
20	699.700003	0.005	715.300002	0.002
30	699.699996	-0.005	715.299999	-0.002
40	699.699998	-0.003	715.299999	-0.001
50	699.699999	-0.002	715.299997	-0.004
50	699.699999	-0.002	715.299998	-0.003
65	699.699998	-0.003	715.299996	-0.005

Frequency Error vs. Voltage

Voltage (Volts)	LTE Band 12			
	Channel Bandwidth: 5 MHz			
	Low Channel		High Channel	
	Frequency (MHz)	Frequency Error (ppm)	Frequency (MHz)	Frequency Error (ppm)
12	699.700002	0.002	715.300001	0.002
10.2	699.700003	0.004	715.300004	0.005
13.8	699.700002	0.003	715.300002	0.003

Note: The fixture defined the normal working voltage of the DC Power Supply is from 10.2 Vdc to 13.8 Vdc.

Frequency Error vs. Temperature

Temp. (°C)	LTE Band 12			
	Channel Bandwidth: 5 MHz			
	Low Channel		High Channel	
	Frequency (MHz)	Frequency Error (ppm)	Frequency (MHz)	Frequency Error (ppm)
-30	699.700003	0.004	715.300002	0.003
-20	699.700002	0.002	715.300001	0.001
-10	699.700003	0.005	715.300003	0.004
0	699.700003	0.005	715.300002	0.003
10	699.700003	0.004	715.300001	0.002
20	699.700002	0.003	715.300004	0.005
30	699.699998	-0.003	715.299998	-0.003
40	699.699998	-0.003	715.299998	-0.002
50	699.699999	-0.002	715.299998	-0.003
50	699.699998	-0.003	715.299997	-0.004
65	699.699997	-0.004	715.299997	-0.005

Frequency Error vs. Voltage

Voltage (Volts)	LTE Band 12			
	Channel Bandwidth: 10 MHz			
	Low Channel		High Channel	
	Frequency (MHz)	Frequency Error (ppm)	Frequency (MHz)	Frequency Error (ppm)
12	699.700003	0.004	715.300001	0.002
10.2	699.700002	0.002	715.300003	0.004
13.8	699.700002	0.003	715.300001	0.001

Note: The fixture defined the normal working voltage of the DC Power Supply is from 10.2 Vdc to 13.8 Vdc.

Frequency Error vs. Temperature

Temp. (°C)	LTE Band 12			
	Channel Bandwidth: 10 MHz			
	Low Channel		High Channel	
	Frequency (MHz)	Frequency Error (ppm)	Frequency (MHz)	Frequency Error (ppm)
-30	699.700003	0.004	715.300003	0.004
-20	699.700004	0.005	715.300002	0.003
-10	699.700002	0.002	715.300002	0.003
0	699.700002	0.003	715.300001	0.002
10	699.700002	0.003	715.300002	0.003
20	699.700003	0.004	715.300002	0.003
30	699.699996	-0.005	715.299998	-0.003
40	699.699998	-0.003	715.299999	-0.002
50	699.699997	-0.005	715.299998	-0.002
50	699.699998	-0.003	715.299999	-0.002
65	699.699999	-0.002	715.299996	-0.005

Frequency Error vs. Voltage

Voltage (Volts)	LTE Band 13			
	Channel Bandwidth: 5 MHz			
	Low Channel		High Channel	
	Frequency (MHz)	Frequency Error (ppm)	Frequency (MHz)	Frequency Error (ppm)
12	779.500004	0.005	784.500003	0.004
10.2	779.500004	0.005	784.500002	0.002
13.8	779.500004	0.004	784.500003	0.004

Note: The fixture defined the normal working voltage of the DC Power Supply is from 10.2 Vdc to 13.8 Vdc.

Frequency Error vs. Temperature

Temp. (°C)	LTE Band 13			
	Channel Bandwidth: 5 MHz			
	Low Channel		High Channel	
	Frequency (MHz)	Frequency Error (ppm)	Frequency (MHz)	Frequency Error (ppm)
-30	779.500002	0.003	784.500003	0.004
-20	779.500003	0.004	784.500004	0.005
-10	779.500002	0.003	784.500001	0.001
0	779.500003	0.004	784.500002	0.003
10	779.500003	0.004	784.500004	0.005
20	779.500004	0.004	784.500001	0.001
30	779.499996	-0.005	784.499998	-0.003
40	779.499997	-0.004	784.499997	-0.003
50	779.499997	-0.004	784.499997	-0.004
50	779.499998	-0.003	784.499998	-0.003
65	779.499996	-0.005	784.499997	-0.004

Frequency Error vs. Voltage

Voltage (Volts)	LTE Band 13	
	Channel Bandwidth: 10 MHz	
	Frequency (MHz)	Frequency Error (ppm)
12	779.500003	0.004
10.2	779.500002	0.002
13.8	779.500002	0.002

Note: The fixture defined the normal working voltage of the DC Power Supply is from 10.2 Vdc to 13.8 Vdc.

Frequency Error vs. Temperature

Temp. (°C)	LTE Band 13	
	Channel Bandwidth: 10 MHz	
	Frequency (MHz)	Frequency Error (ppm)
-30	779.500003	0.004
-20	779.500003	0.004
-10	779.500003	0.004
0	779.500003	0.003
10	779.500004	0.005
20	779.500001	0.002
30	779.499997	-0.004
40	779.499997	-0.004
50	779.499996	-0.005
50	779.499998	-0.003
65	779.499998	-0.003

4.4 Occupied Bandwidth Measurement

4.4.1 Limits of Occupied Bandwidth Measurement

The width of a frequency band such that, below the lower and above the upper frequency limits, the mean powers emitted are each equal to a specified percentage 0.5 % of the total mean power of a given emission.

4.4.2 Test Procedure

- The conducted occupied bandwidth used the power splitter via EUT RF power connector between simulation base station and spectrum analyzer.
- Use OBW measurement function of Spectrum analyzer to measure 99 % occupied bandwidth.

4.4.3 Test Setup

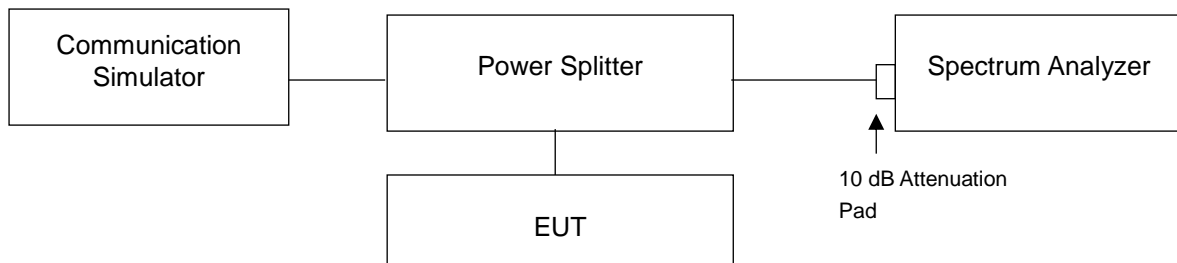

4.4.4 Test Result

LTE Band 4							
Channel Bandwidth: 1.4 MHz				Channel Bandwidth: 3 MHz			
Channel	Frequency (MHz)	99 % Occupied Bandwidth (MHz)		Channel	Frequency (MHz)	99 % Occupied Bandwidth (MHz)	
		QPSK	16QAM			QPSK	16QAM
19957	1710.7	1.0886	0.9098	19965	1711.5	1.0818	0.9127
20175	1732.5	1.0897	0.9086	20175	1732.5	1.0788	0.9115
20393	1754.3	1.0862	0.9082	20385	1753.5	1.0855	0.9090

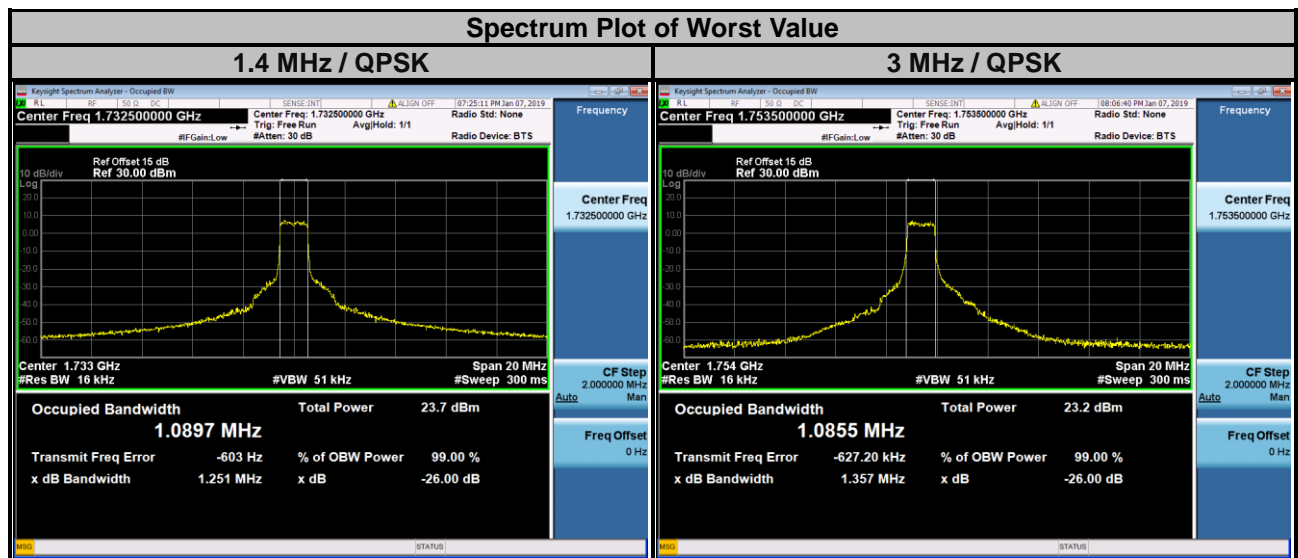

LTE Band 4							
Channel Bandwidth: 5 MHz				Channel Bandwidth: 10 MHz			
Channel	Frequency (MHz)	99 % Occupied Bandwidth (MHz)		Channel	Frequency (MHz)	99 % Occupied Bandwidth (MHz)	
		QPSK	16QAM			QPSK	16QAM
19975	1712.5	1.0786	0.9202	20000	1715.0	1.0900	0.9163
20175	1732.5	1.0827	0.9242	20175	1732.5	1.0887	0.9148
20375	1752.5	1.0828	0.9191	20350	1750.0	1.0914	0.9116

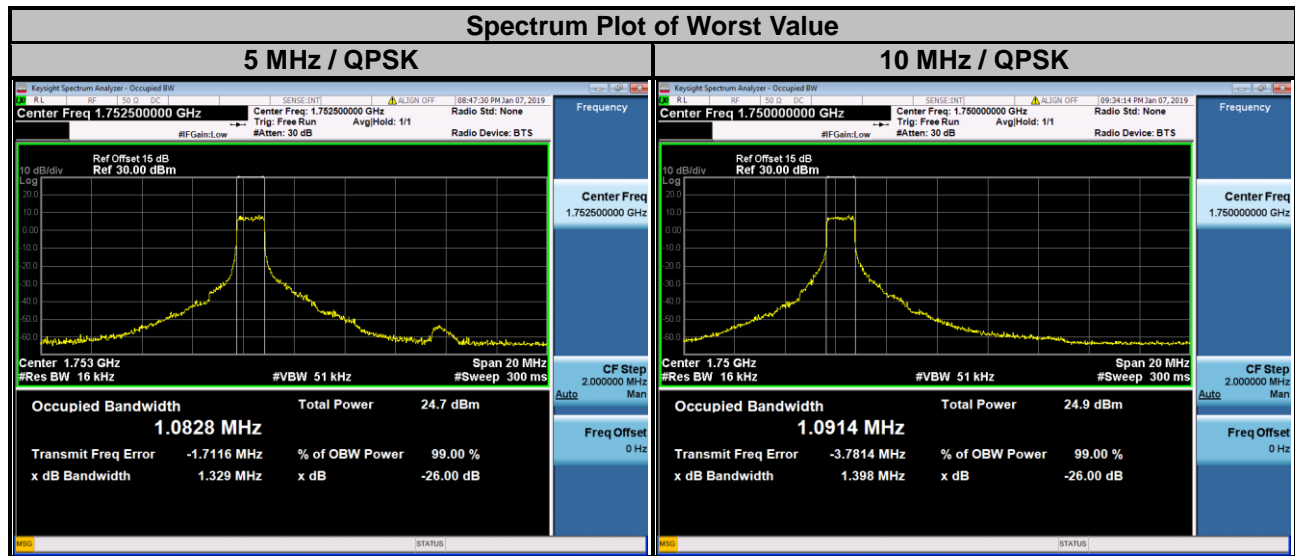

LTE Band 4							
Channel Bandwidth: 15 MHz				Channel Bandwidth: 20 MHz			
Channel	Frequency (MHz)	99 % Occupied Bandwidth (MHz)		Channel	Frequency (MHz)	99 % Occupied Bandwidth (MHz)	
		QPSK	16QAM			QPSK	16QAM
20025	1717.5	1.0942	0.9222	20050	1720.0	1.0930	0.9186
20175	1732.5	1.0931	0.9246	20175	1732.5	1.0905	0.9179
20325	1747.5	1.0946	0.9247	20300	1745.0	1.0914	0.9173

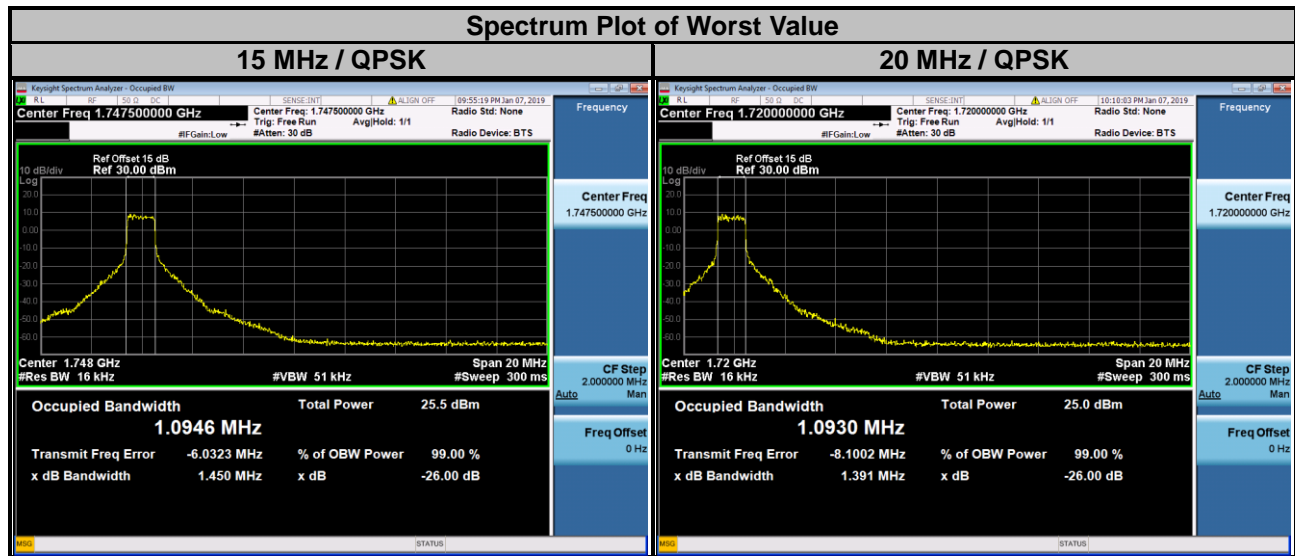

LTE Band 12							
Channel Bandwidth: 1.4 MHz				Channel Bandwidth: 3 MHz			
Channel	Frequency (MHz)	99 % Occupied Bandwidth (MHz)		Channel	Frequency (MHz)	99 % Occupied Bandwidth (MHz)	
		QPSK	16QAM			QPSK	16QAM
23017	699.7	1.0890	0.9092	23025	700.5	1.0866	0.9151
23095	707.5	1.0864	0.9107	23095	707.5	1.0859	0.9110
23173	715.3	1.0869	0.9092	23165	714.5	1.0859	0.9139

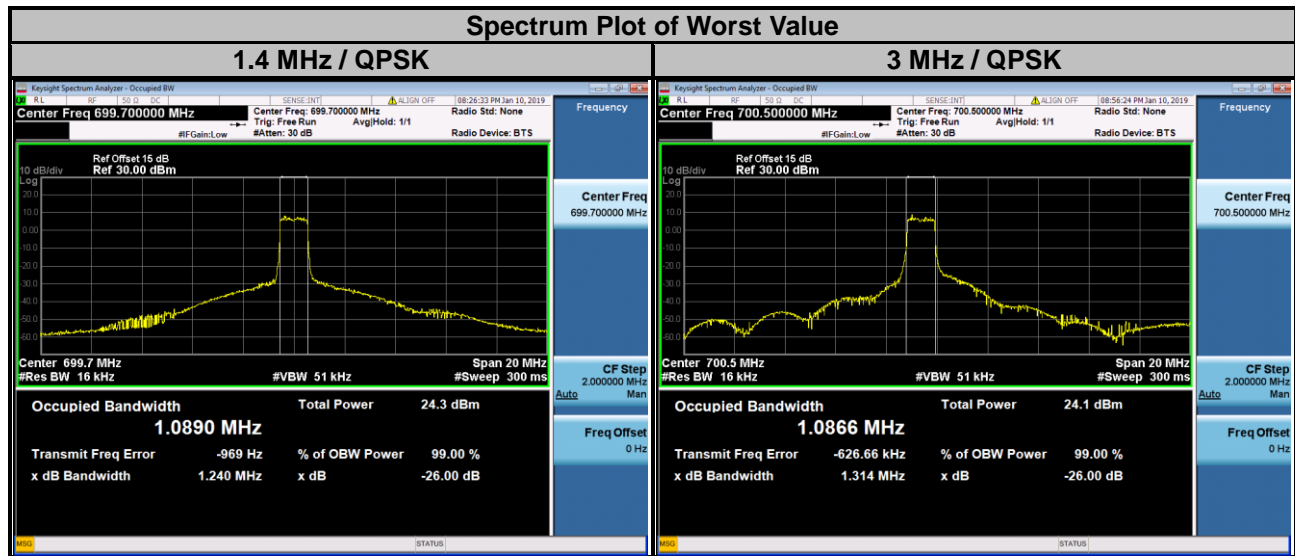

LTE Band 12							
Channel Bandwidth: 5 MHz				Channel Bandwidth: 10 MHz			
Channel	Frequency (MHz)	99 % Occupied Bandwidth (MHz)		Channel	Frequency (MHz)	99 % Occupied Bandwidth (MHz)	
		QPSK	16QAM			QPSK	16QAM
23035	701.5	1.0908	0.9206	23060	704.0	1.0923	0.9157
23095	707.5	1.0807	0.9246	23095	707.5	1.0915	0.9175
23155	713.5	1.0919	0.9160	23130	711.0	1.0917	0.9167

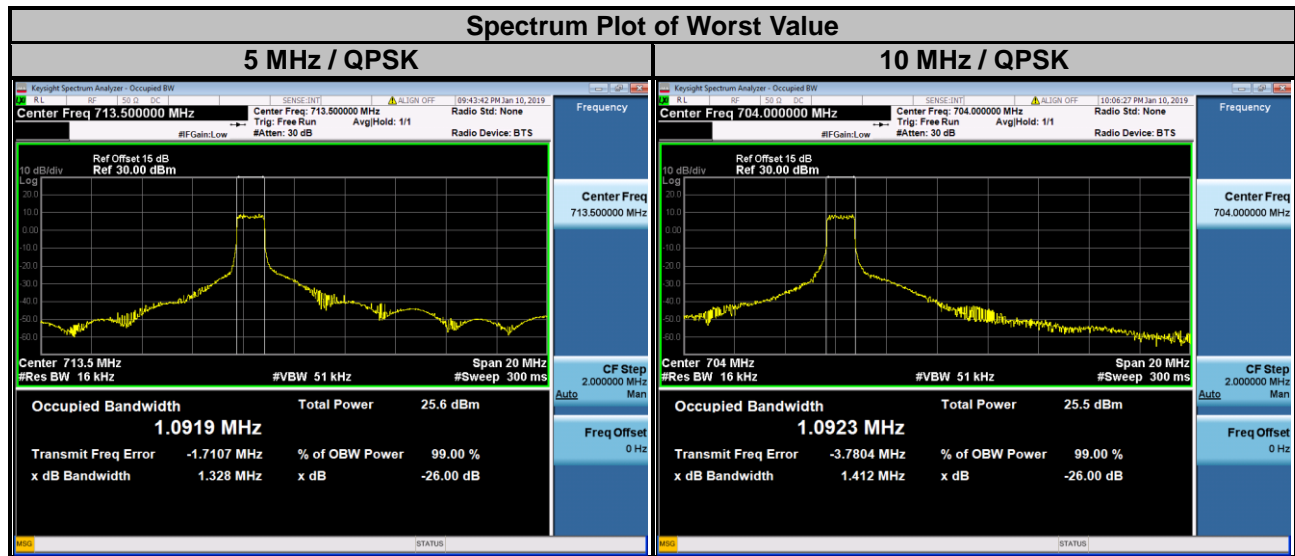

LTE Band 13							
Channel Bandwidth: 5 MHz				Channel Bandwidth: 10 MHz			
Channel	Frequency (MHz)	99 % Occupied Bandwidth (MHz)		Channel	Frequency (MHz)	99 % Occupied Bandwidth (MHz)	
		QPSK	16QAM			QPSK	16QAM
23205	779.5	1.0852	0.9210	23230	782.0	1.0908	0.9171
23230	782.0	1.0816	0.9228				
23255	784.5	1.0837	0.9149				

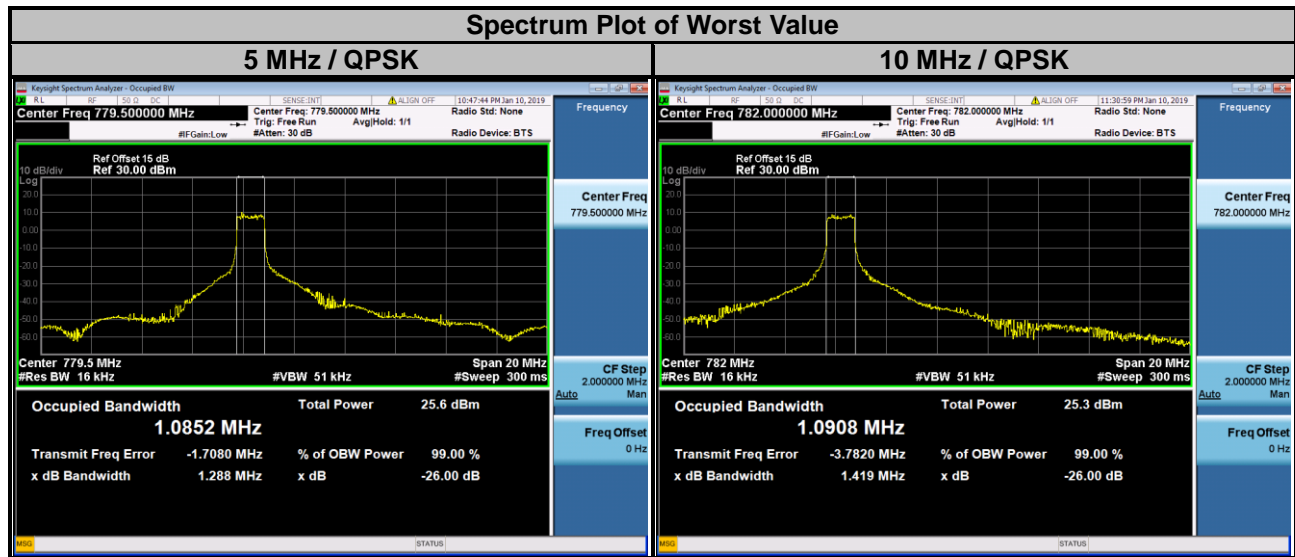

4.5 Band Edge Measurement

4.5.1 Limits of Band Edge Measurement

For operations in the 698-787 MHz band, the power of any emission outside a licensee's frequency band(s) of operation shall be attenuated below the transmitter power (P) within the licensed band(s) of operation, measured in watts, by at least $43 + 10 \log (P)$ dB. Compliance with this provision is based on the use of measurement instrumentation employing a resolution bandwidth of 100 kilohertz or greater.

However, in the 100 kilohertz bands immediately outside and adjacent to a licensee's frequency block, a resolution bandwidth of at least 30 kHz may be employed.

For operations in the 746-758 MHz band and the 776-788 MHz band, the power of any emission outside a licensee's frequency band(s) of operation shall be attenuated below the transmitter power (P) within the licensed band(s) of operation, measured in watts, by at least $43 + 10 \log (P)$ dB.

On all frequencies between 763-775 MHz and 793-805 MHz, by a factor no less than $65 + 10 \log (P)$ dB in a 6.25 kHz band segment, for mobile and portable stations.

For operations in the 1710–1755 MHz bands, the power of any emission outside a licensee's frequency block shall be attenuated below the transmitter power (P) by at least $43 + 10 \log (P)$ dB.

4.5.2 Test Setup

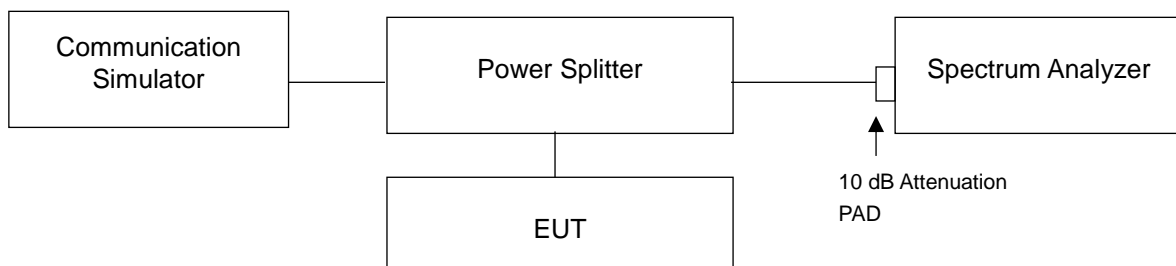

4.5.3 Test Procedures

- All measurements were done at low and high operational frequency range.
- The center frequency of spectrum is the band edge frequency and span is 5 MHz. RB of the spectrum is 16 kHz and VB of the spectrum is 51 kHz.
- Record the max. trace plot into the test report.

4.5.4 Test Results

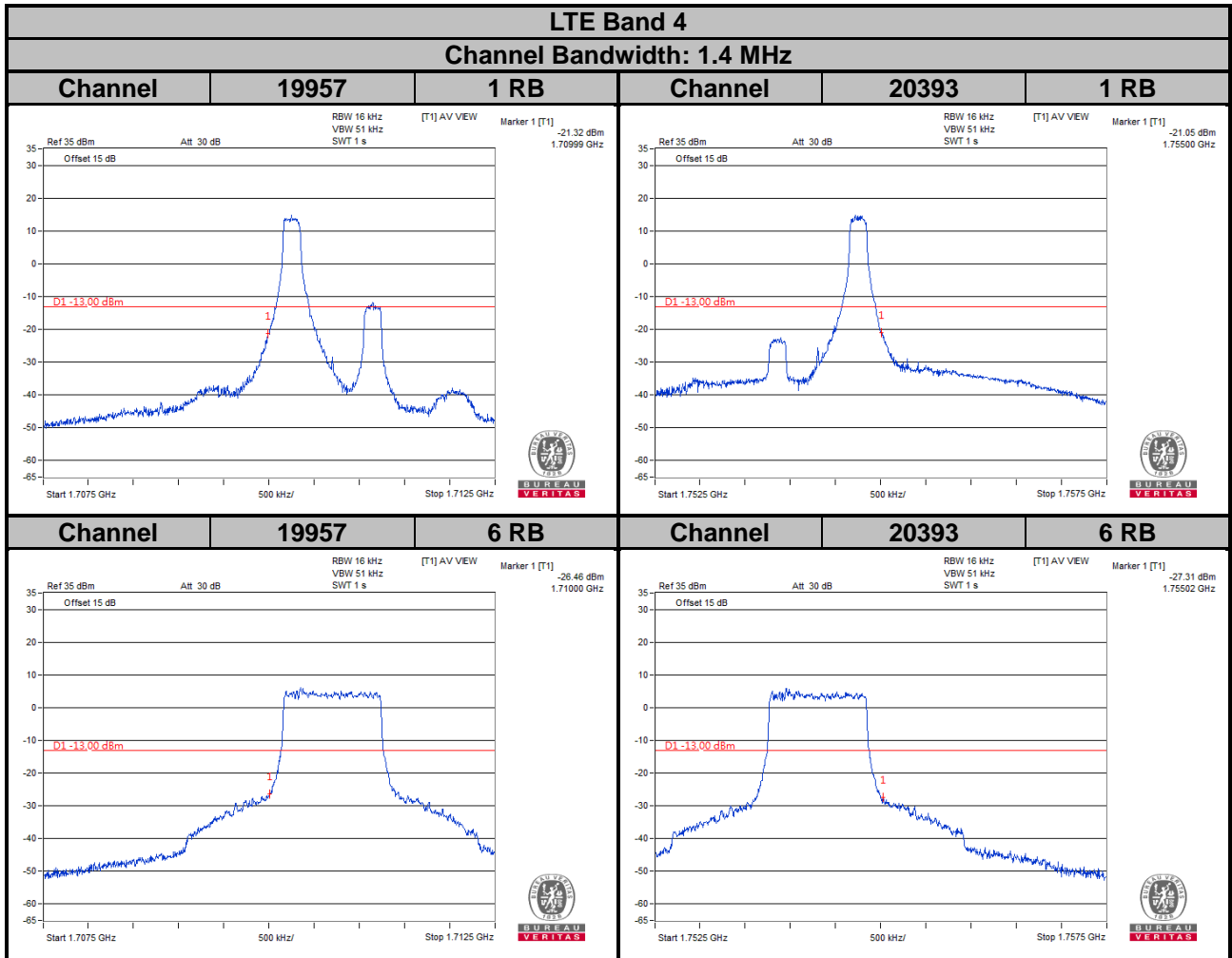

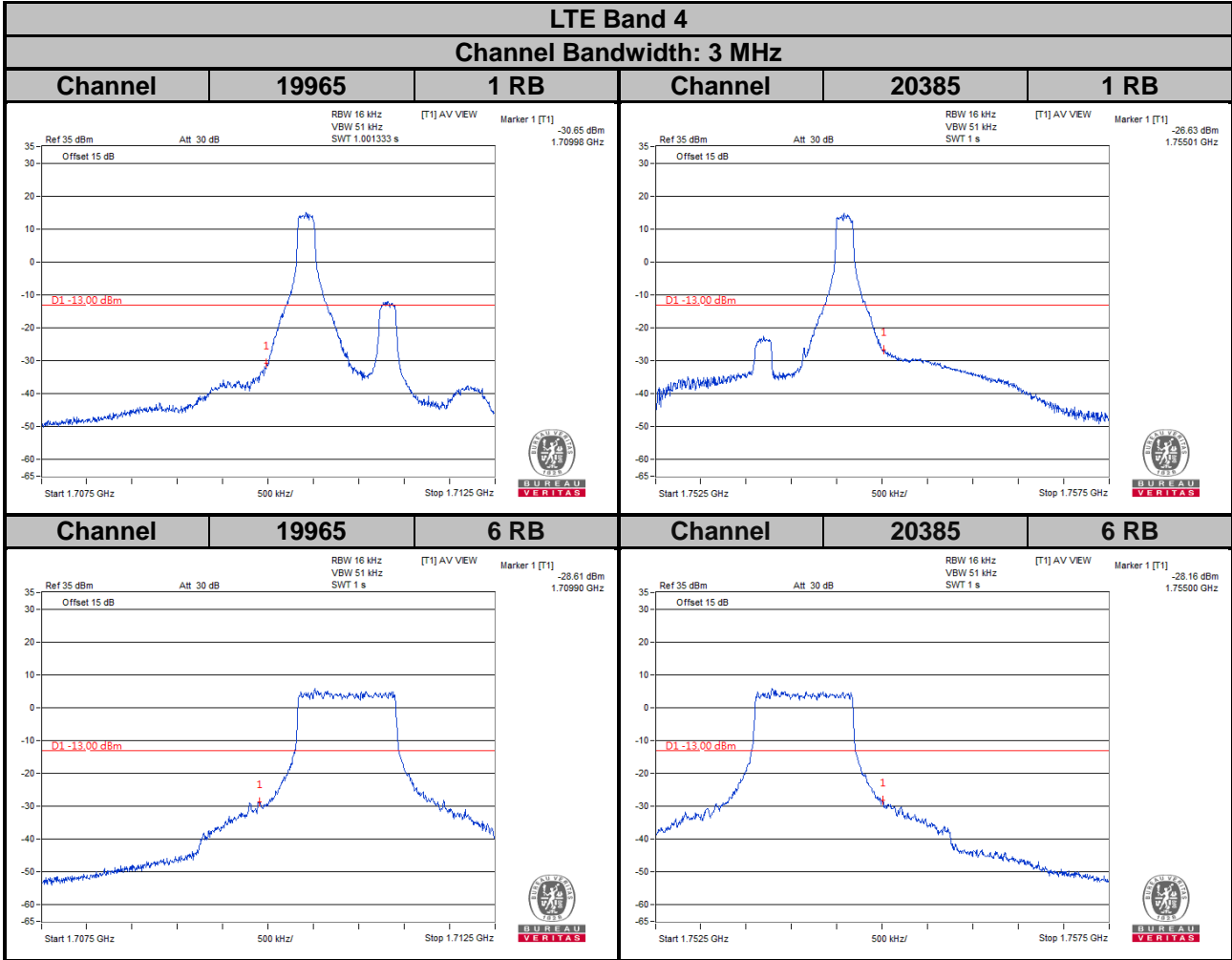

LTE Band 4
Channel Bandwidth: 5 MHz

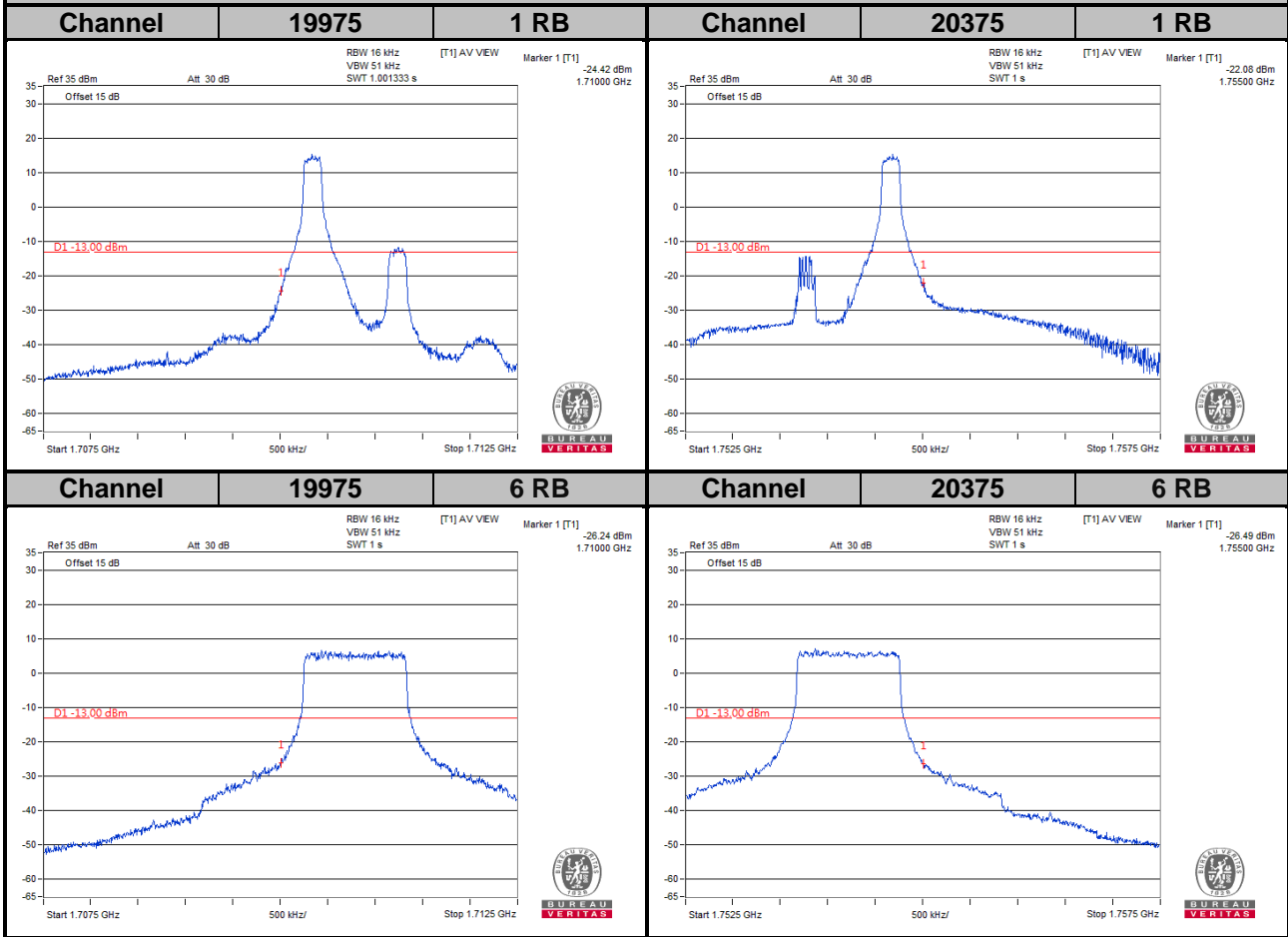

LTE Band 4

Channel Bandwidth: 10 MHz

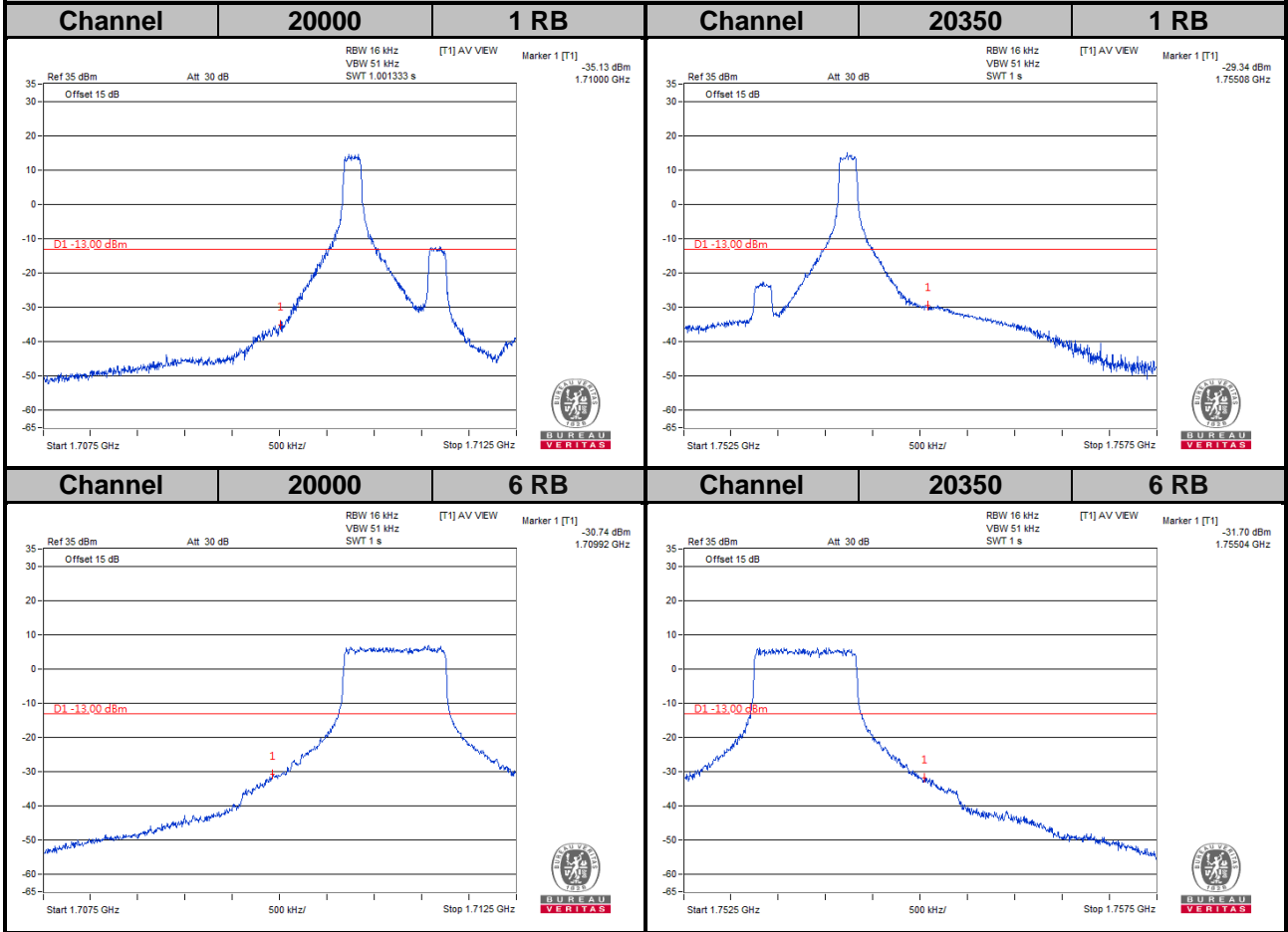

LTE Band 4
Channel Bandwidth: 15 MHz

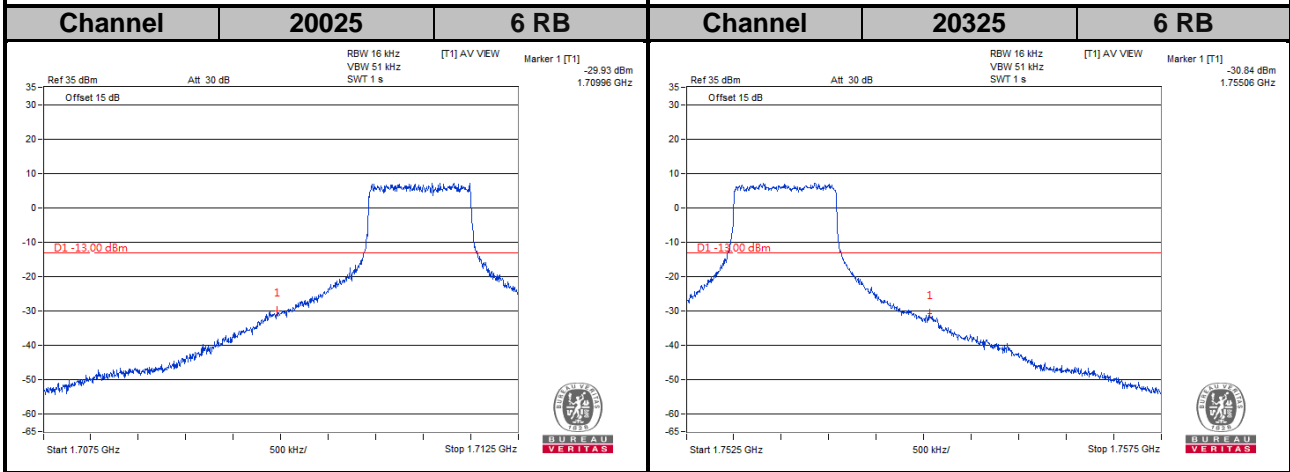
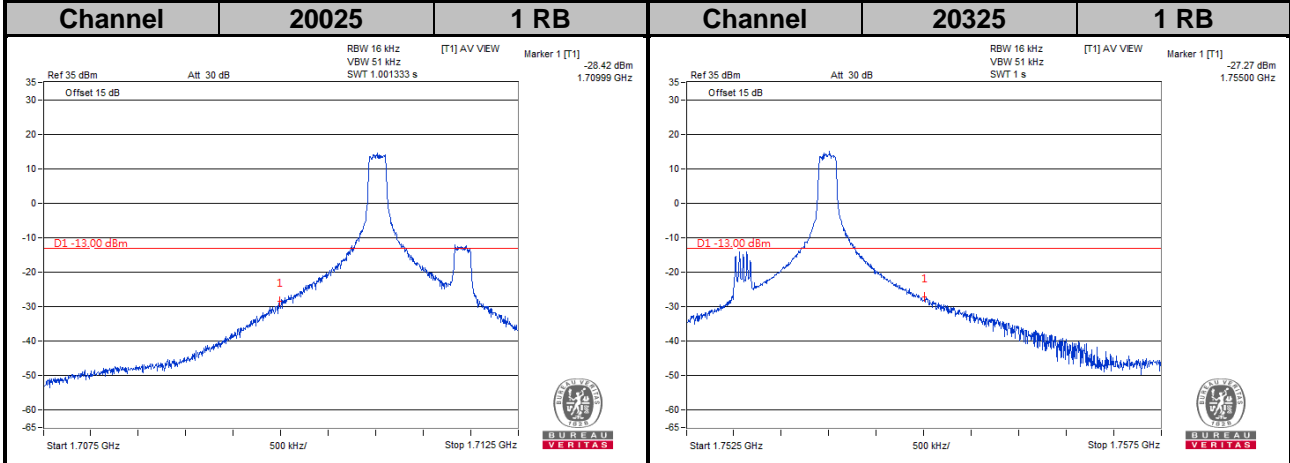

LTE Band 4
Channel Bandwidth: 20 MHz

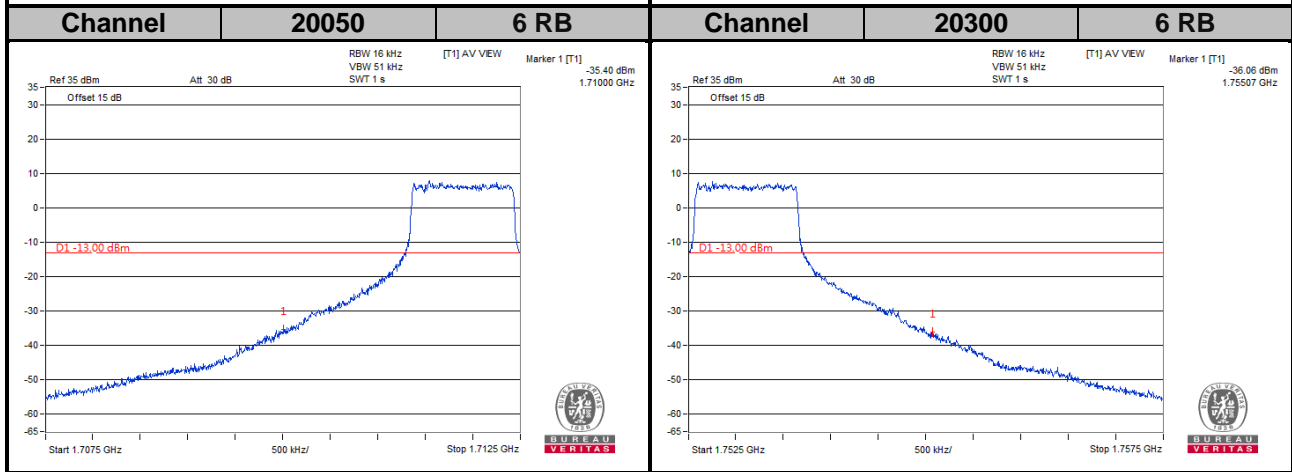
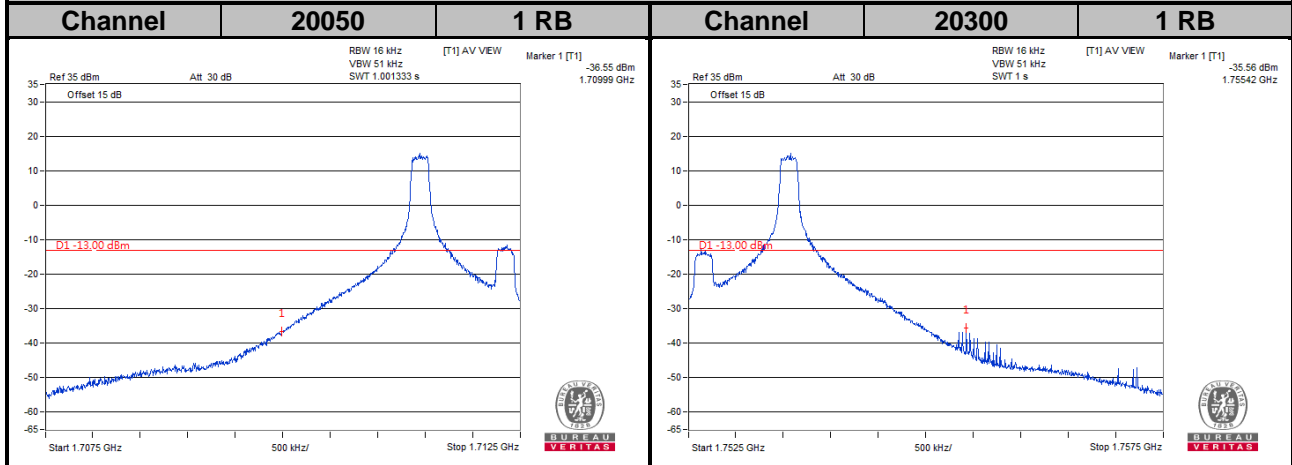

LTE Band 12
Channel Bandwidth: 1.4 MHz

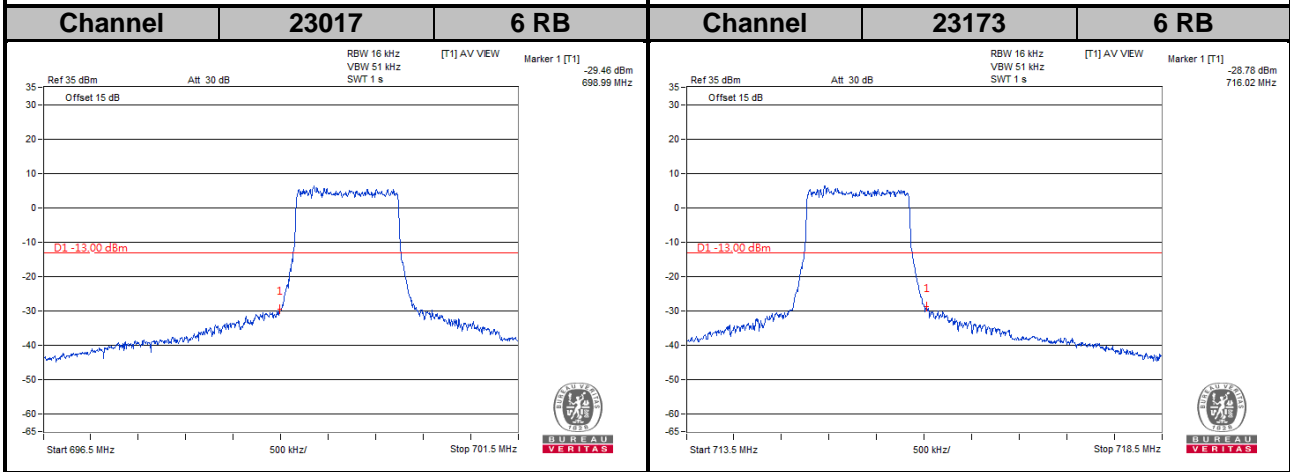
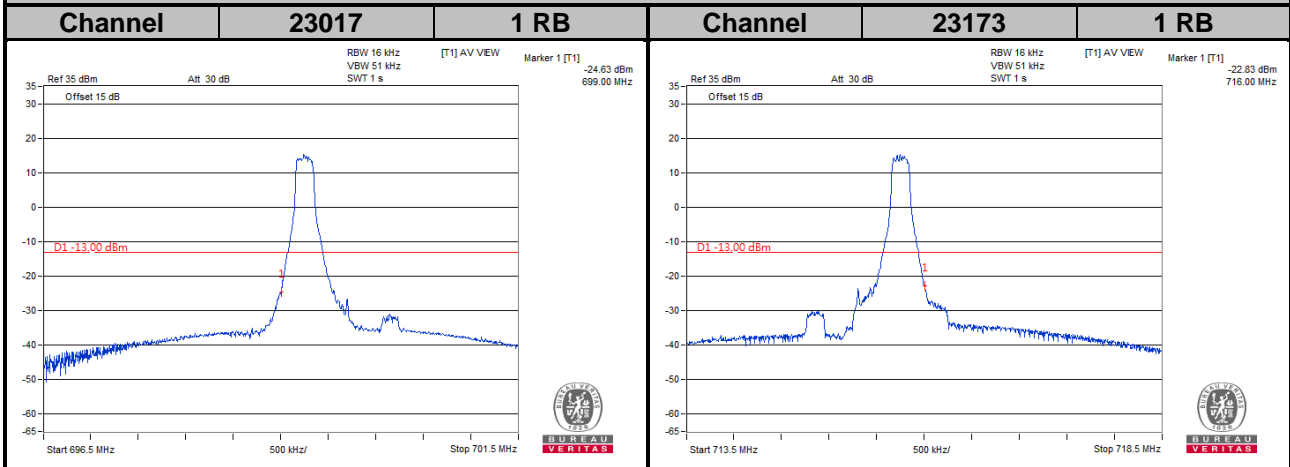

LTE Band 12
Channel Bandwidth: 3 MHz

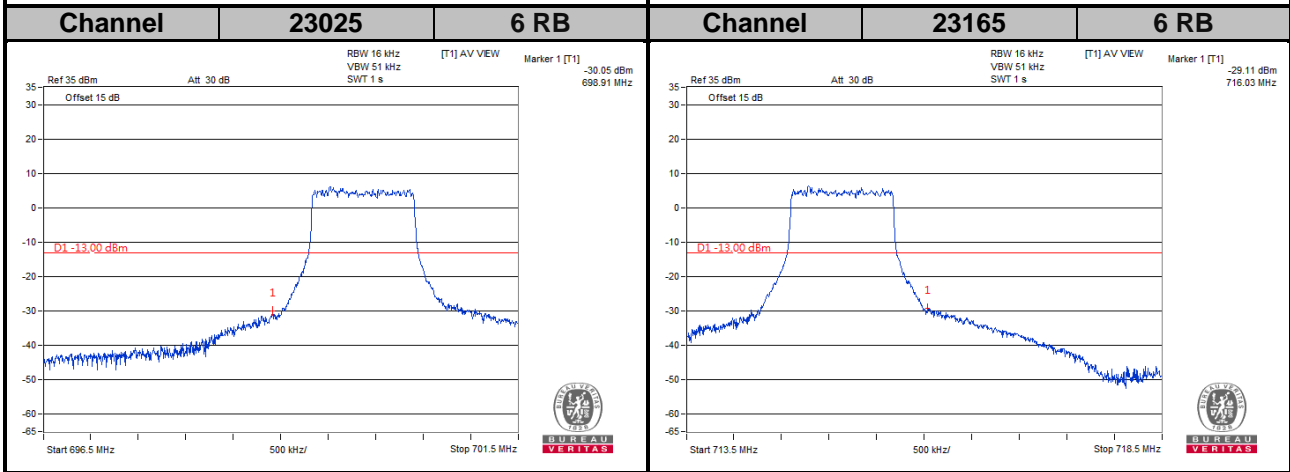
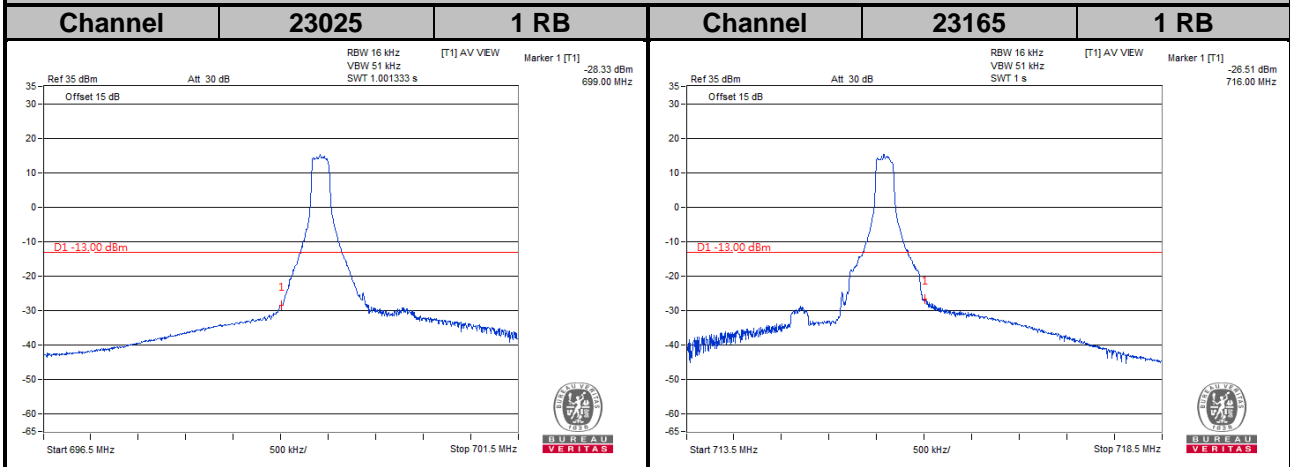

LTE Band 12
Channel Bandwidth: 5 MHz

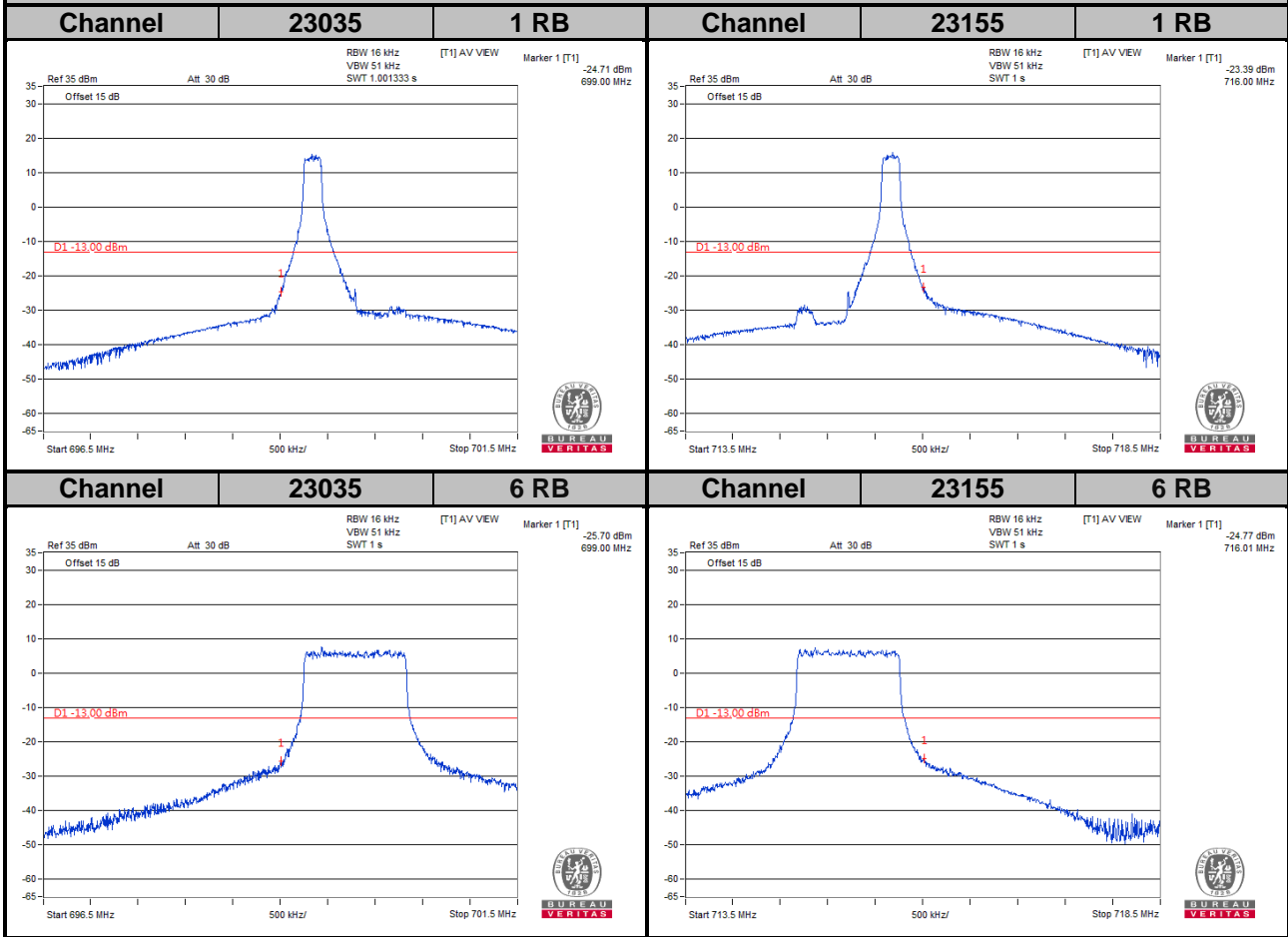

LTE Band 12
Channel Bandwidth: 10 MHz

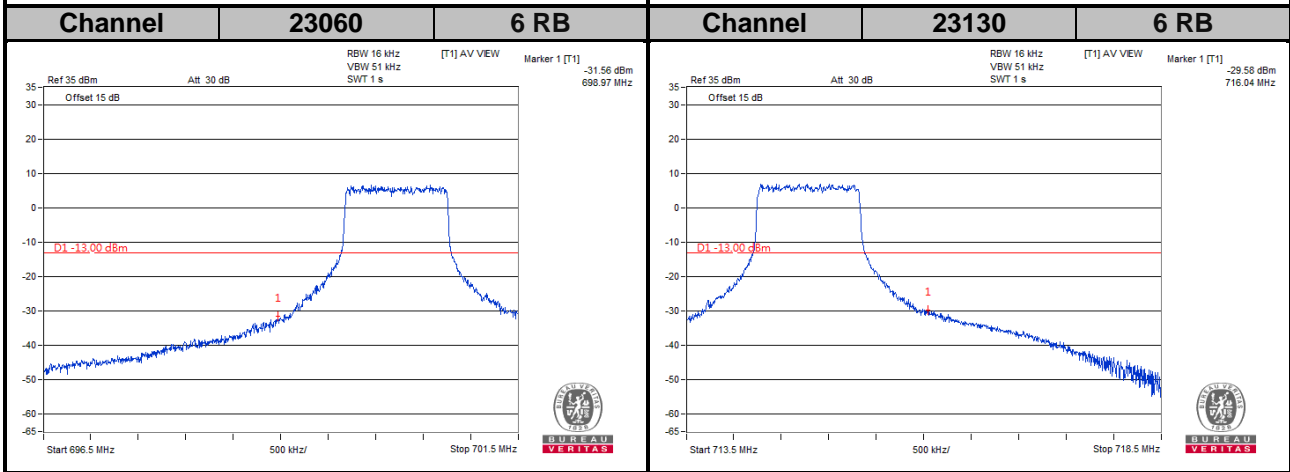
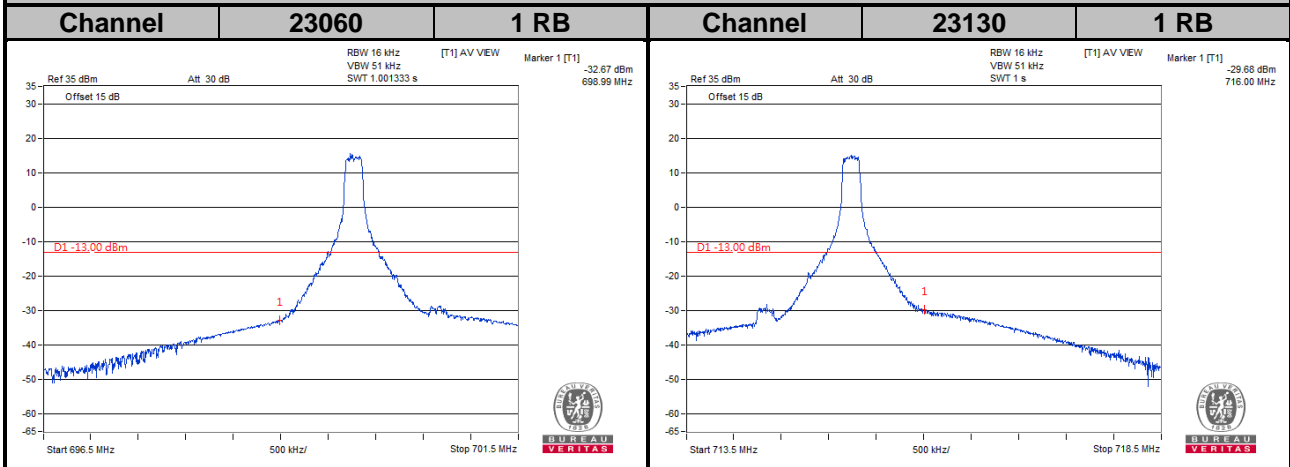

LTE Band 13
Channel Bandwidth: 5 MHz

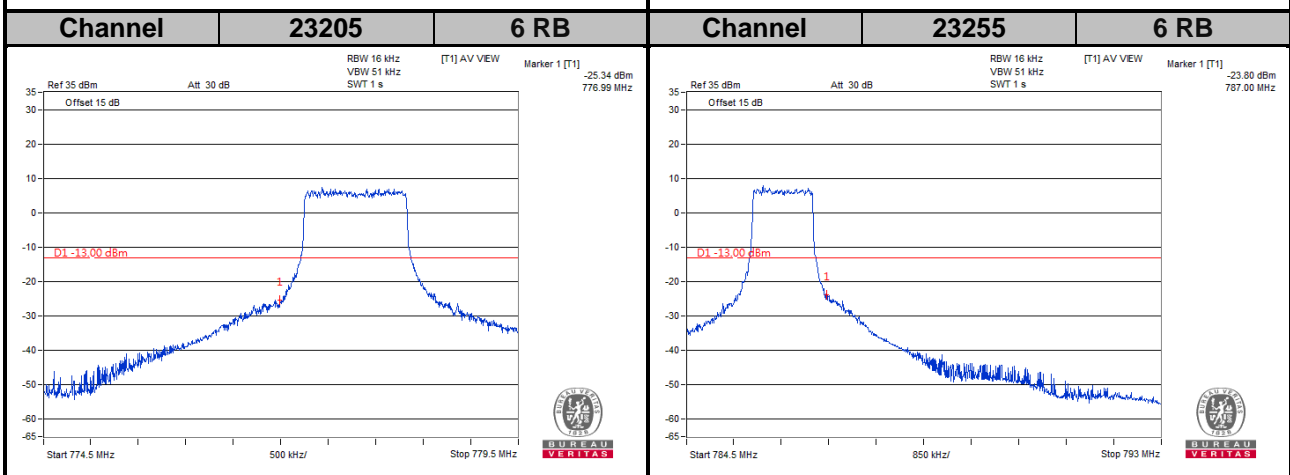
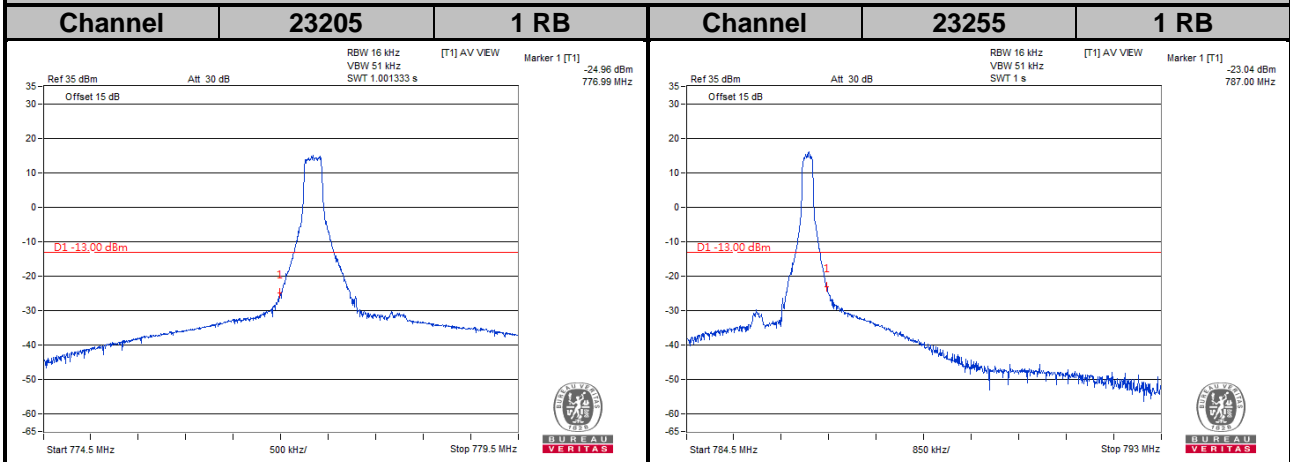

LTE Band 13

Channel Bandwidth: 10 MHz

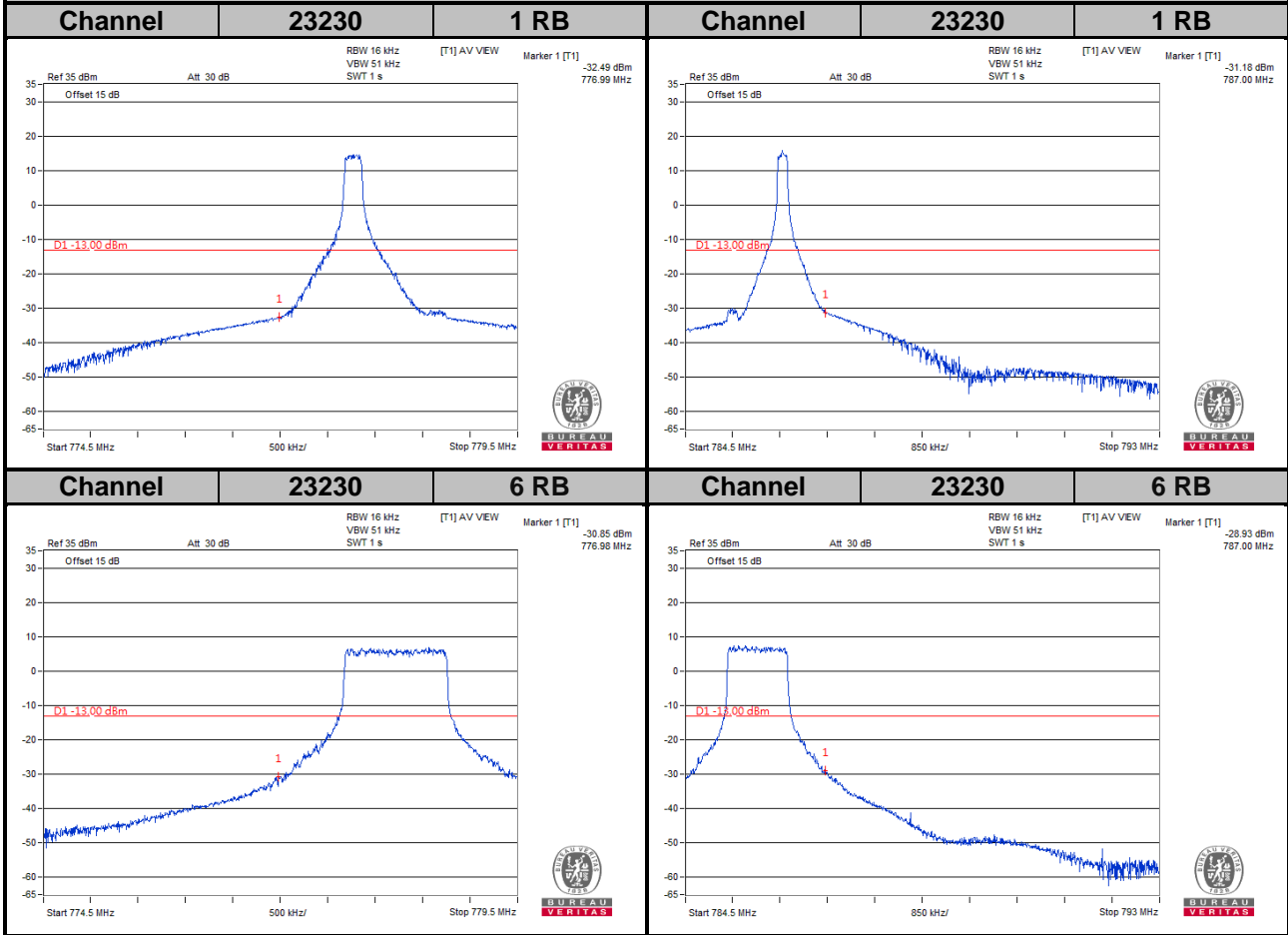

Emission Mask

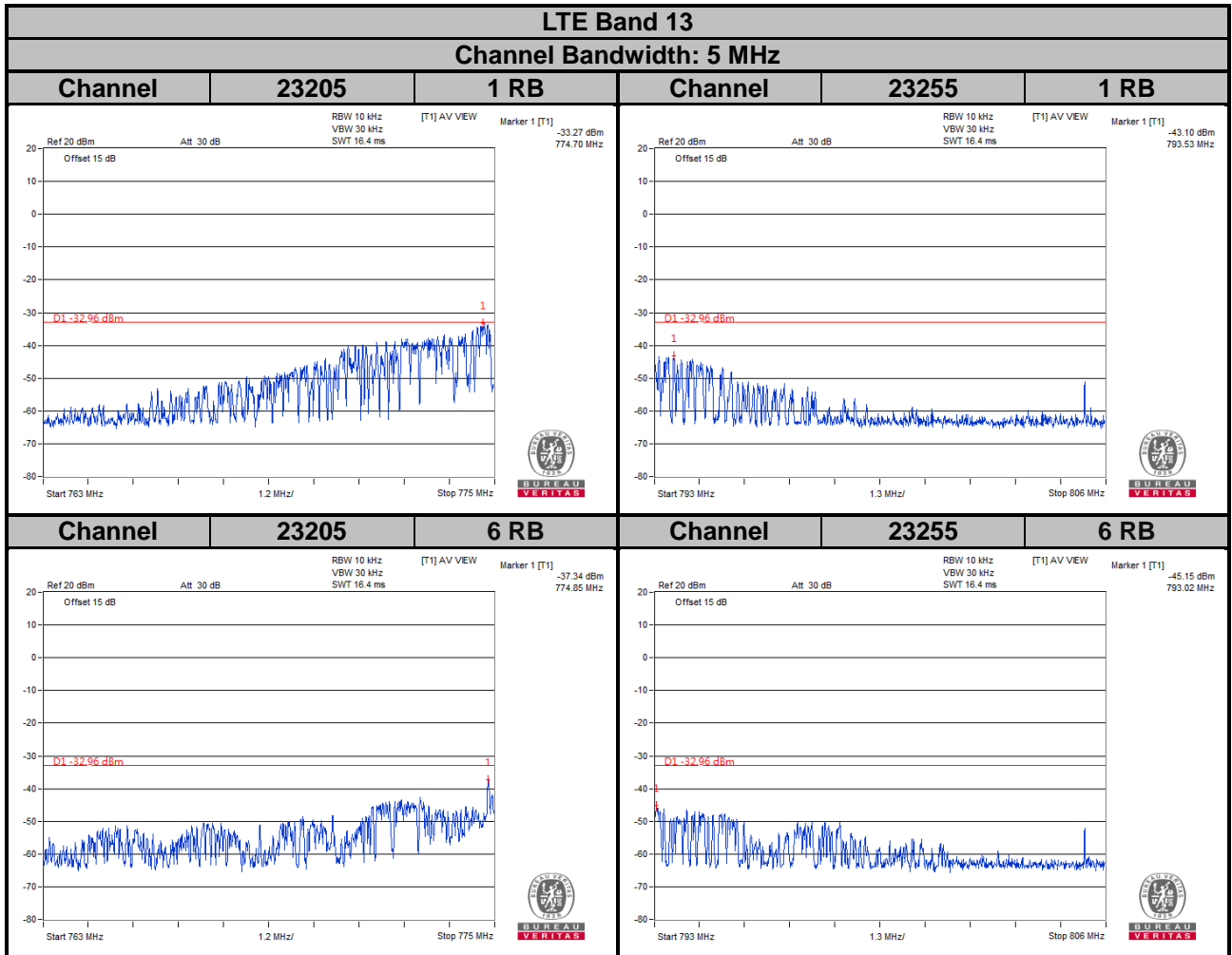

For the 763 - 775 MHz and 793 - 805 MHz band, the FCC limit is $65 + 10 \log(P[\text{watt}])$ in a 6.25 kHz bandwidth. Since it was not possible to set the resolution bandwidth to 6.25 kHz with the available equipment, a bandwidth of 10 kHz was used instead to show compliance. By using a 10 kHz bandwidth on the spectrum analyzer.

$$10 \log(10 \text{ kHz} / 6.25 \text{ kHz}) = 2.04 \text{ dB}$$

$$\text{Limit line} = -35 \text{ dBm} + 2.04 \text{ dB} = -32.96 \text{ dBm}$$

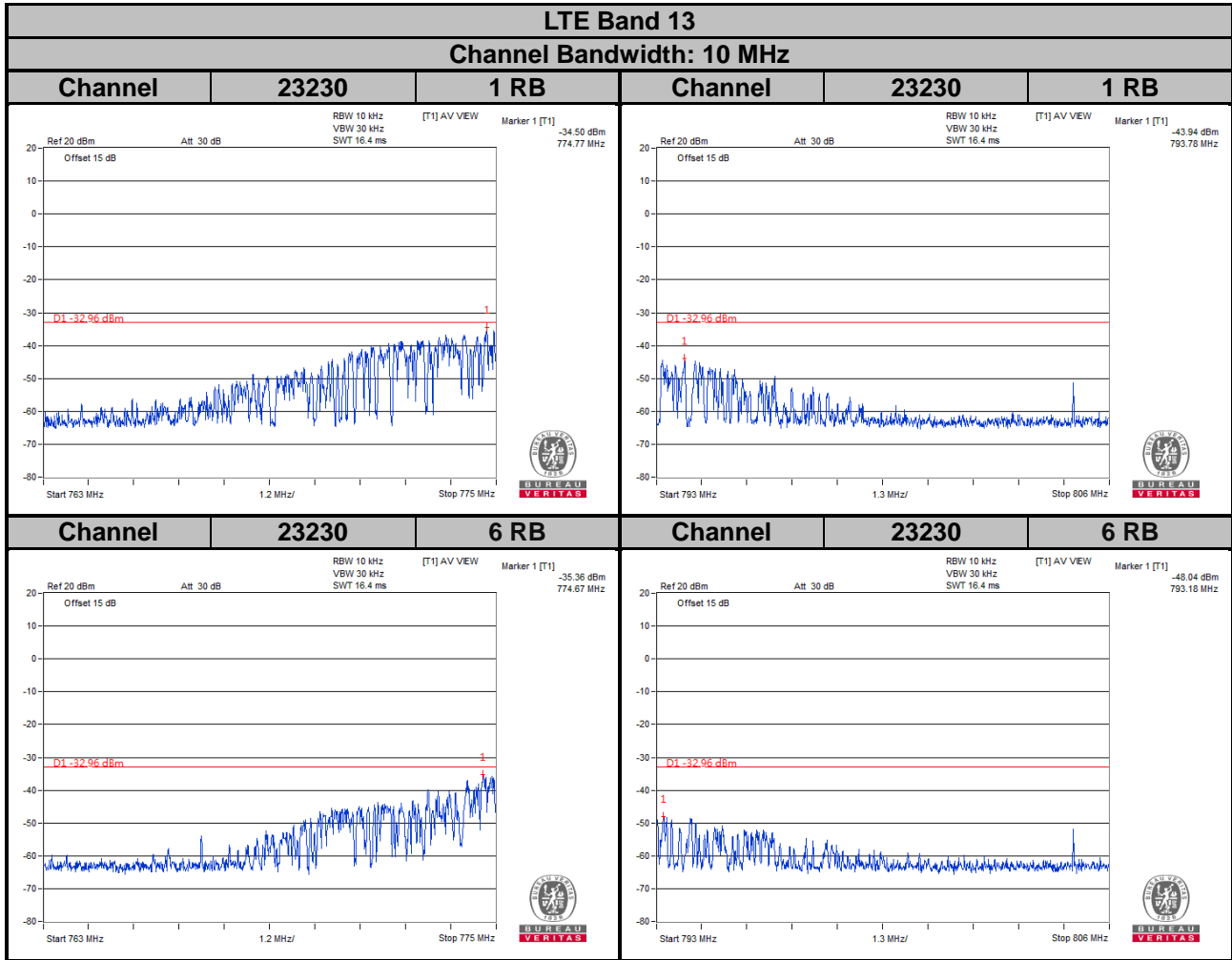

For the 763 - 775 MHz and 793 - 805 MHz band, the FCC limit is $65+10\log(P[\text{watt}])$ in a 6.25 kHz bandwidth. Since it was not possible to set the resolution bandwidth to 6.25 kHz with the available equipment, a bandwidth of 10 kHz was used instead to show compliance. By using a 10 kHz bandwidth on the spectrum analyzer.

$$10\log(10\text{kHz}/6.25\text{kHz}) = 2.04 \text{ dB}$$

Limit line = $-35 \text{ dBm} + 2.04 \text{ dB} = -32.96 \text{ dBm}$

4.6 Peak to Average Ratio

4.6.1 Limits of Peak to Average Ratio Measurement

In measuring transmissions in this band using an average power technique, the peak to-average ratio (PAR) of the transmission may not exceed 13 dB.

4.6.2 Test Setup

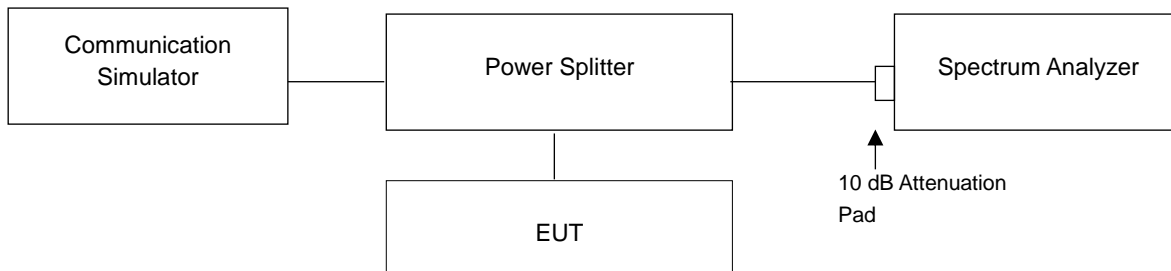

4.6.3 Test Procedures

1. Set resolution/measurement bandwidth \geq signal's occupied bandwidth;
2. Set the number of counts to a value that stabilizes the measured CCDF curve;
3. Record the maximum PAPR level associated with a probability of 0.1 %.

4.6.4 Test Results

LTE Band 4							
Channel Bandwidth: 1.4 MHz				Channel Bandwidth: 3 MHz			
Channel	Frequency (MHz)	Peak to Average Ratio (dB)		Channel	Frequency (MHz)	Peak to Average Ratio (dB)	
		QPSK	16QAM			QPSK	16QAM
19957	1710.7	4.71	5.51	19965	1711.5	4.61	5.52
20175	1732.5	4.54	5.45	20175	1732.5	4.54	5.47
20393	1754.3	4.57	5.48	20385	1753.5	4.52	5.43

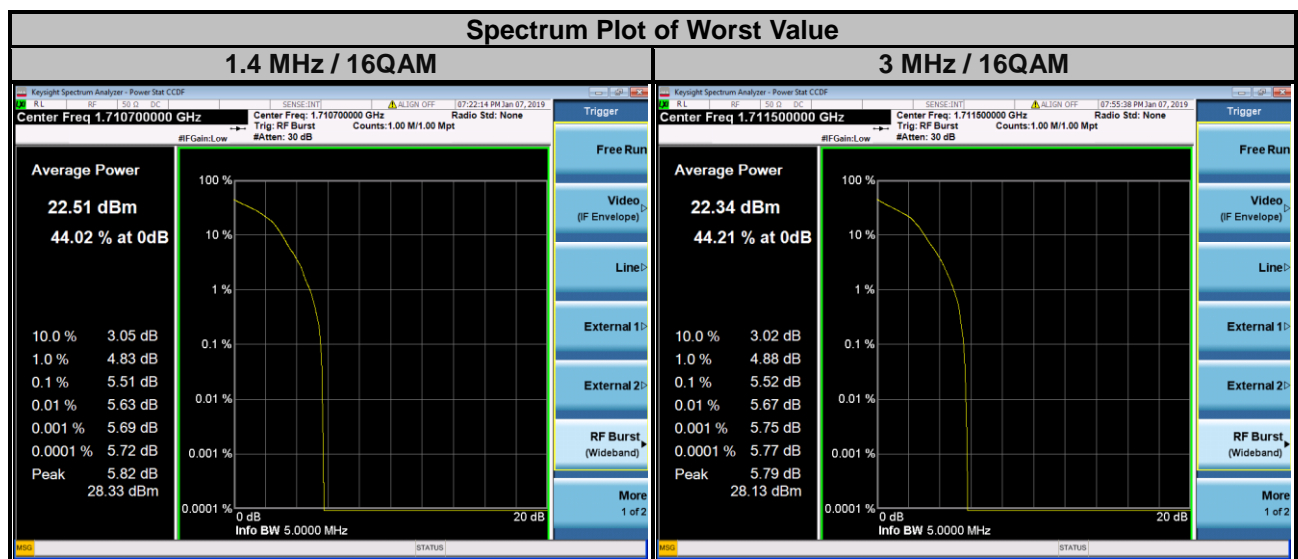

LTE Band 4							
Channel Bandwidth: 5 MHz				Channel Bandwidth: 10 MHz			
Channel	Frequency (MHz)	Peak to Average Ratio (dB)		Channel	Frequency (MHz)	Peak to Average Ratio (dB)	
		QPSK	16QAM			QPSK	16QAM
19975	1712.5	4.73	5.38	20000	1715.0	4.61	5.31
20175	1732.5	4.67	5.33	20175	1732.5	4.56	5.22
20375	1752.5	4.65	5.19	20350	1750.0	4.55	5.19

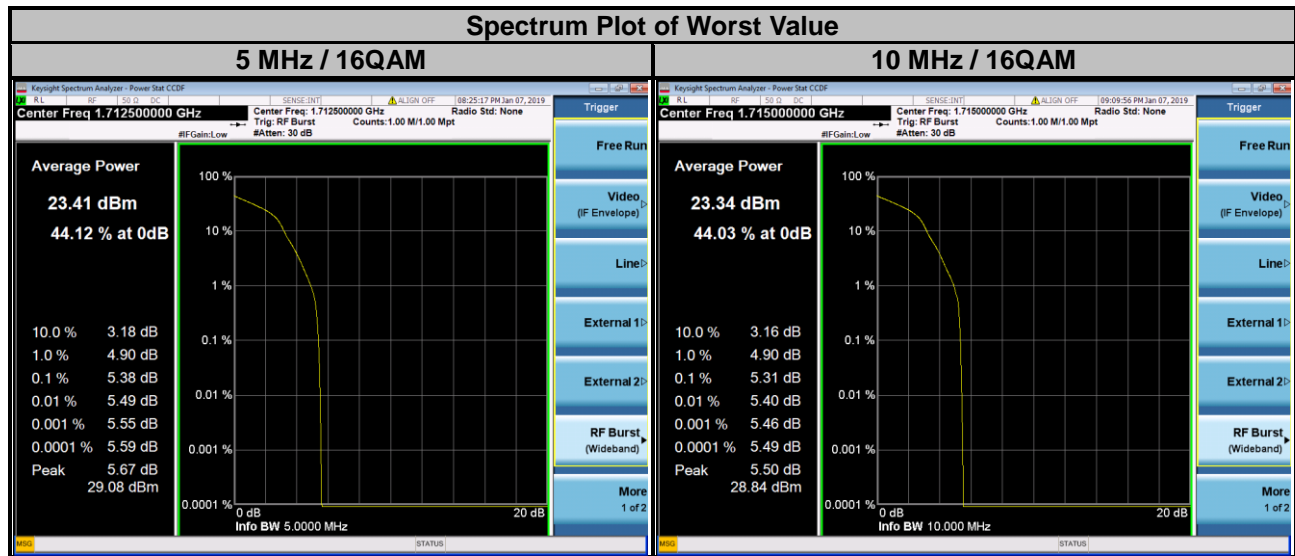

LTE Band 4							
Channel Bandwidth: 15 MHz				Channel Bandwidth: 20 MHz			
Channel	Frequency (MHz)	Peak to Average Ratio (dB)		Channel	Frequency (MHz)	Peak to Average Ratio (dB)	
		QPSK	16QAM			QPSK	16QAM
20025	1717.5	4.59	5.23	20050	1720.0	4.60	5.30
20175	1732.5	4.60	5.16	20175	1732.5	4.55	5.44
20325	1747.5	4.45	5.29	20300	1745.0	4.50	5.26

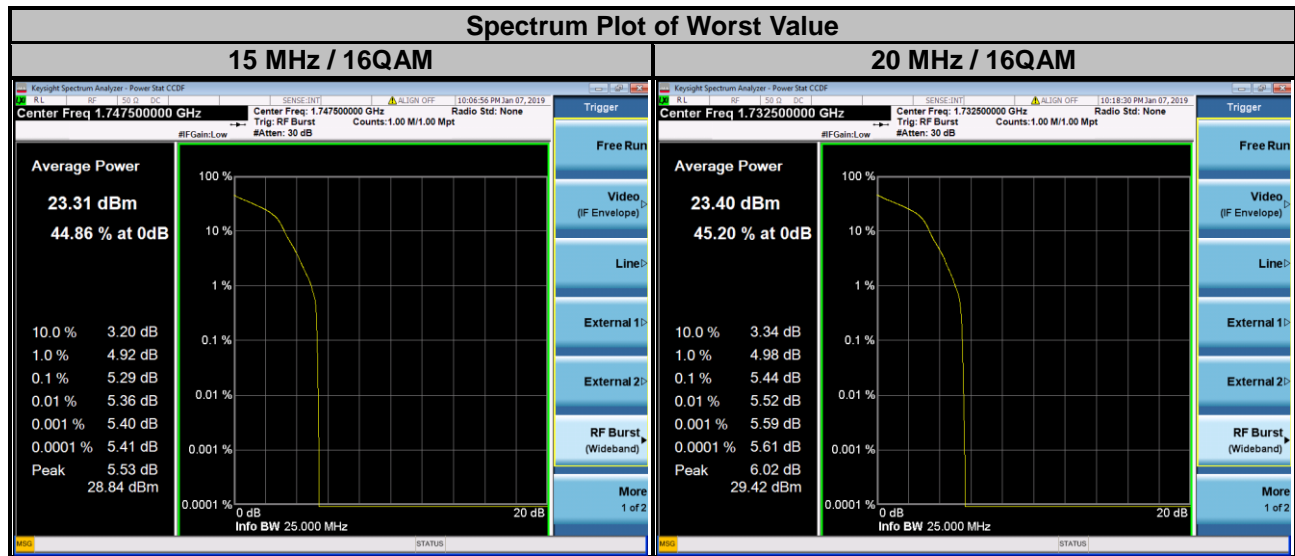

LTE Band 12							
Channel Bandwidth: 1.4 MHz				Channel Bandwidth: 3 MHz			
Channel	Frequency (MHz)	Peak to Average Ratio (dB)		Channel	Frequency (MHz)	Peak to Average Ratio (dB)	
		QPSK	16QAM			QPSK	16QAM
23017	699.7	5.26	6.29	23025	700.5	5.17	6.13
23095	707.5	5.24	6.25	23095	707.5	5.15	6.11
23173	715.3	5.23	6.19	23165	714.5	5.13	6.10

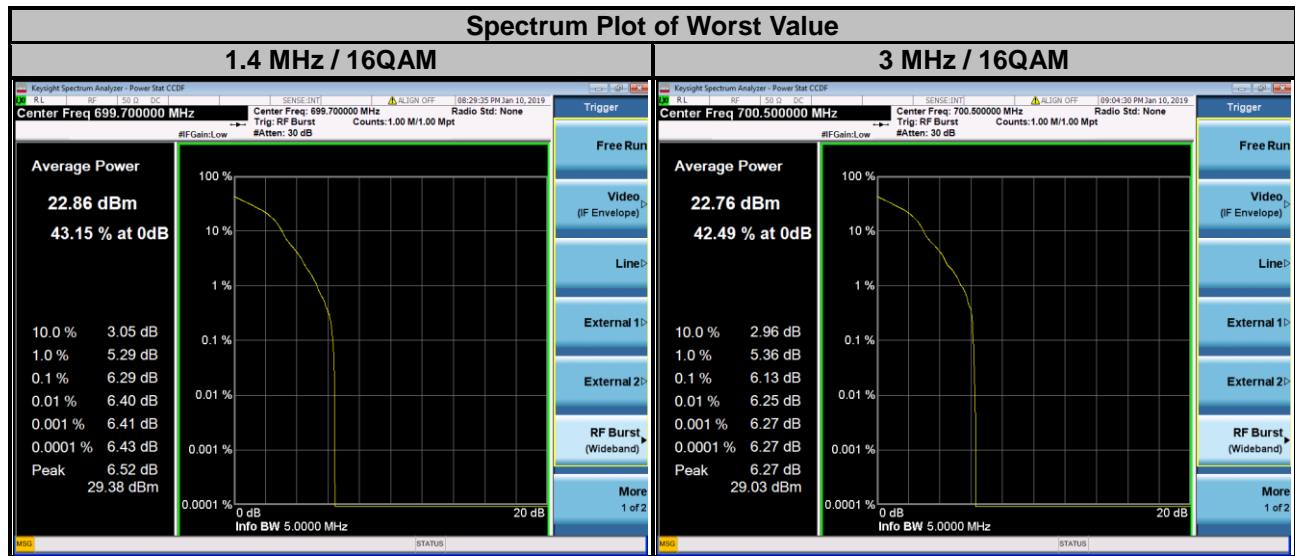

LTE Band 12							
Channel Bandwidth: 5 MHz				Channel Bandwidth: 10 MHz			
Channel	Frequency (MHz)	Peak to Average Ratio (dB)		Channel	Frequency (MHz)	Peak to Average Ratio (dB)	
		QPSK	16QAM			QPSK	16QAM
23035	701.5	5.19	6.05	23060	704.0	5.09	5.96
23095	707.5	5.17	6.11	23095	707.5	5.09	5.98
23155	713.5	5.17	6.11	23130	711.0	5.08	5.99

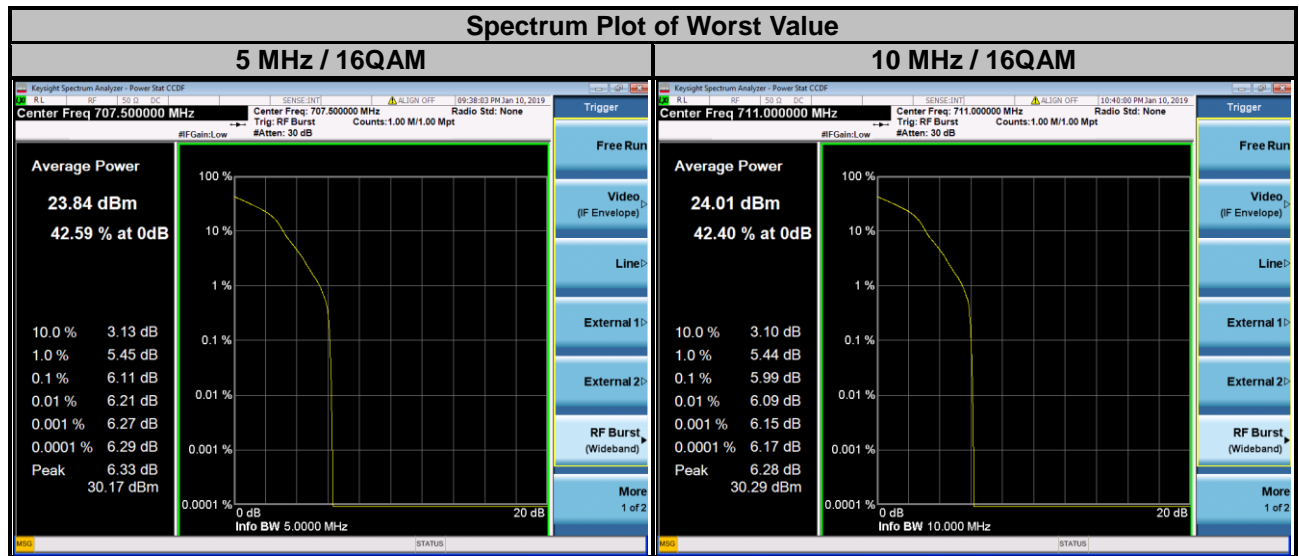

LTE Band 13							
Channel Bandwidth: 5 MHz				Channel Bandwidth: 10 MHz			
Channel	Frequency (MHz)	Peak to Average Ratio (dB)		Channel	Frequency (MHz)	Peak to Average Ratio (dB)	
		QPSK	16QAM			QPSK	16QAM
23205	779.5	5.31	5.94	23230	782.0	5.23	5.83
23230	782.0	5.25	5.84				
23255	784.5	5.22	5.82				

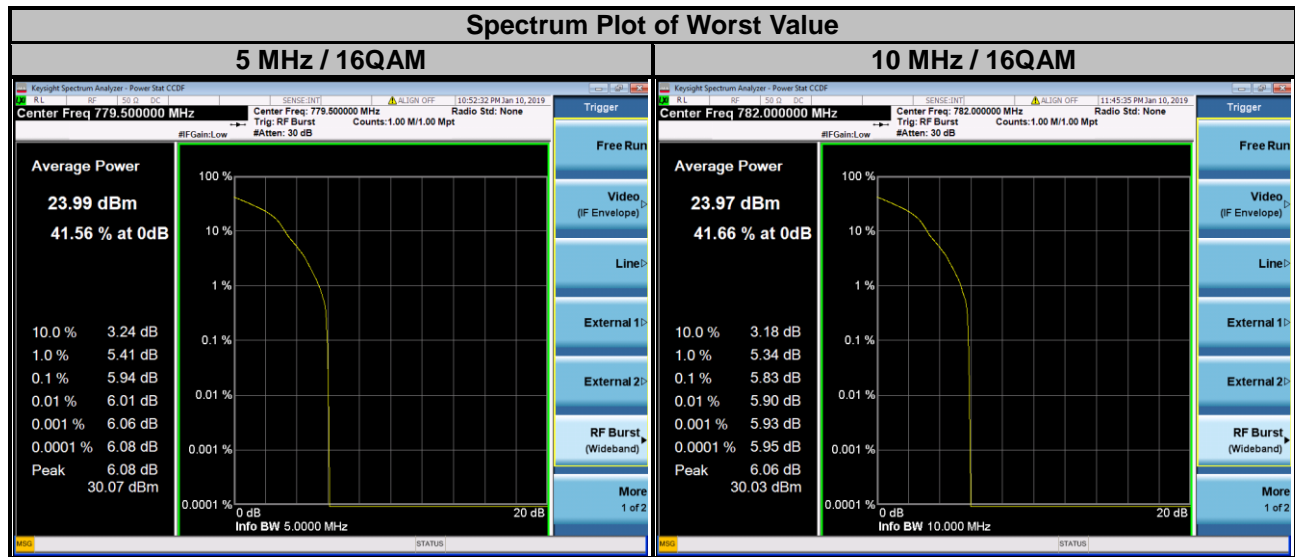

4.7 Conducted Spurious Emissions

4.7.1 Limits of Conducted Spurious Emissions Measurement

The power of any emission outside a licensee's frequency block shall be attenuated below the transmitter power (P) by at least $43 + 10 \log (P)$ dB. The limit of emission is equal to -13 dBm.

4.7.2 Test Setup

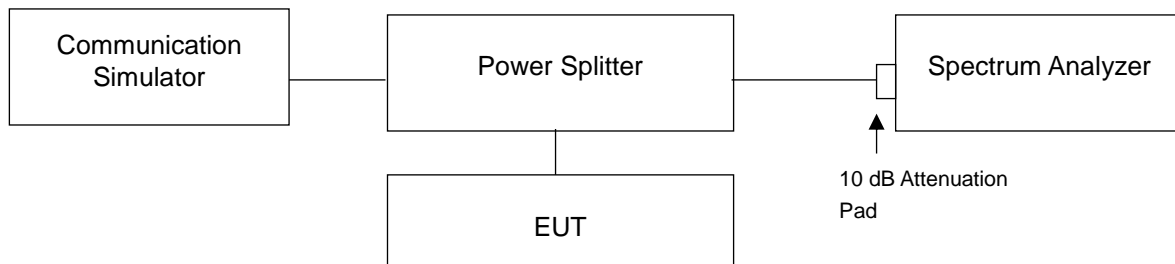

4.7.3 Test Procedure

- The EUT makes a phone call to the communication simulator. All measurements were done at low, middle and high operational frequency range.
- Measuring frequency range is from 9 kHz to 1 GHz. 10 dB attenuation pad is connected with spectrum. RBW = 100 kHz and VBW = 300 kHz is used for conducted emission measurement.
- Measuring frequency range is from 1 GHz to 10 GHz / 26.5 GHz / 27 GHz. 10 dB attenuation pad is connected with spectrum. RBW = 1 MHz and VBW = 3 MHz is used for conducted emission measurement.

4.7.4 Test Results

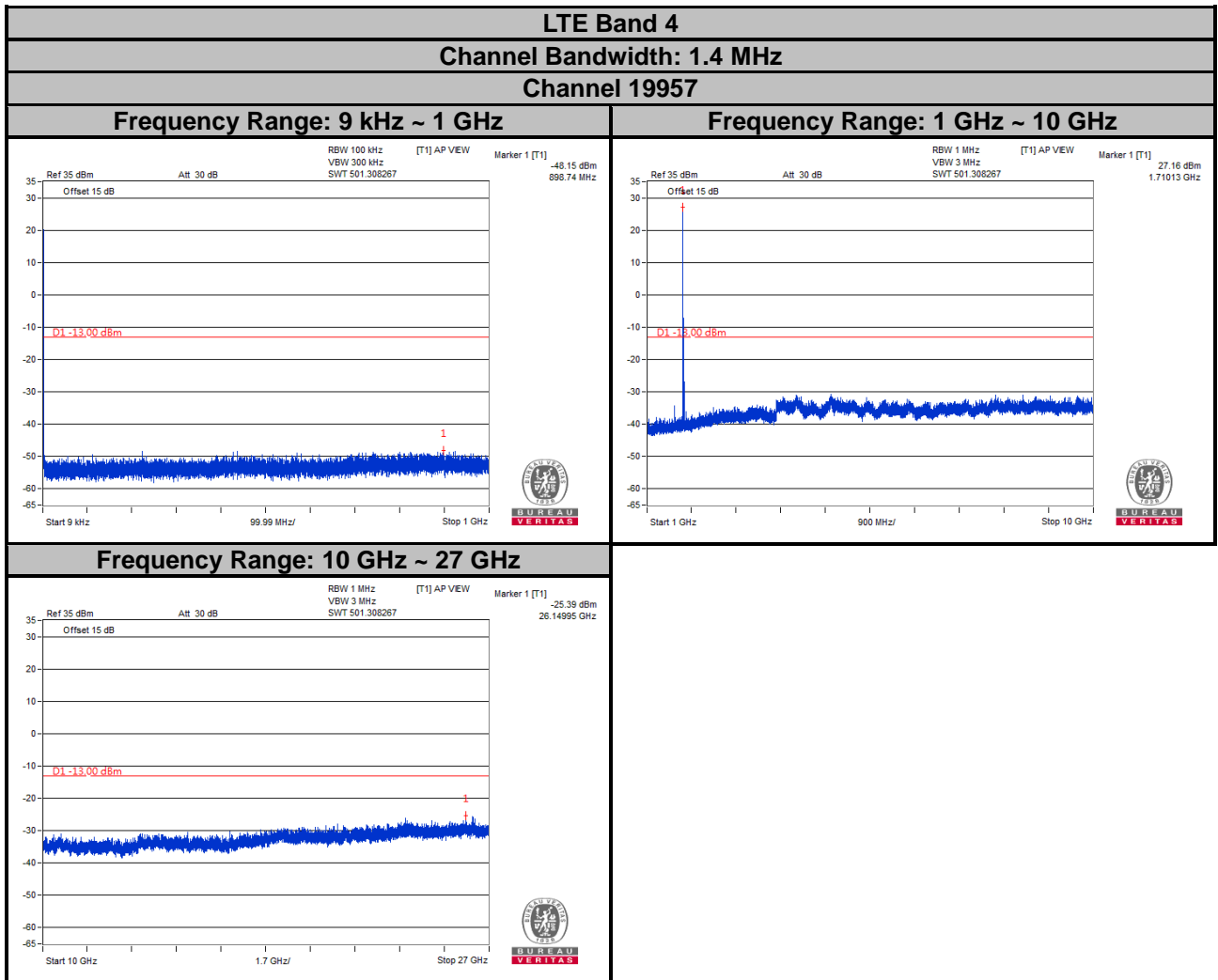

Note: The signal over the limit in 9 kHz is from spectrum analyzer.

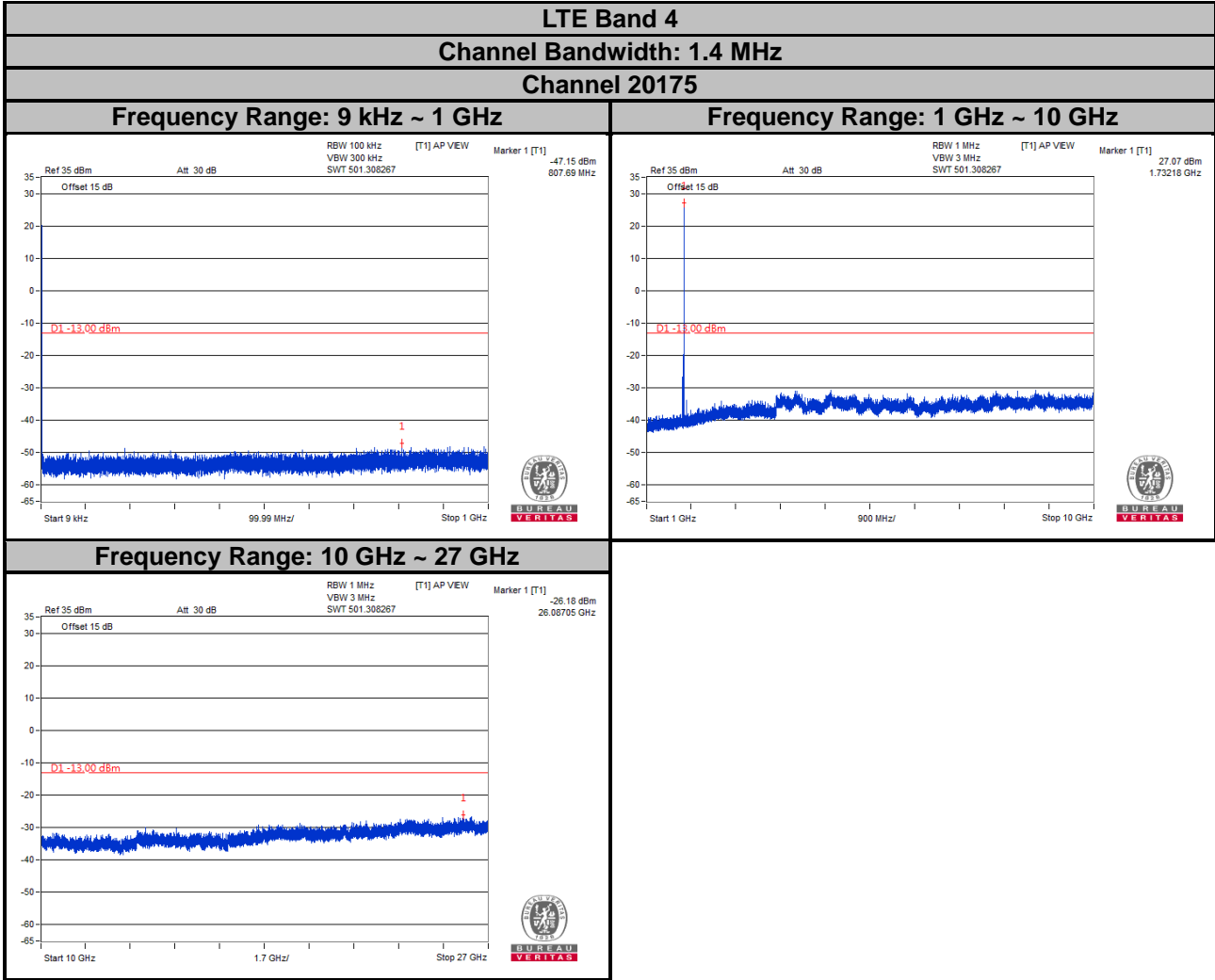

Note: The signal over the limit in 9 kHz is from spectrum analyzer.

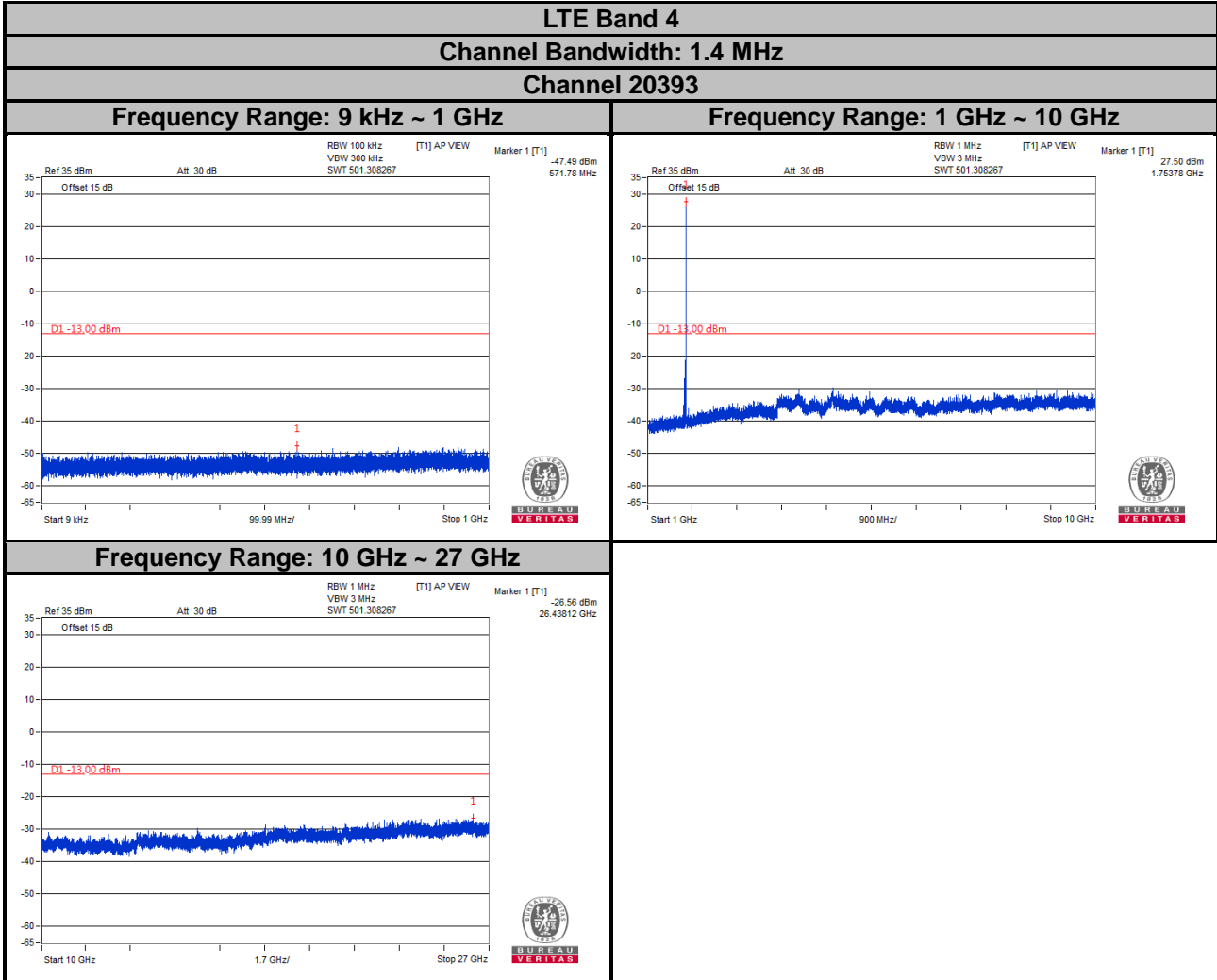

Note: The signal over the limit in 9 kHz is from spectrum analyzer.

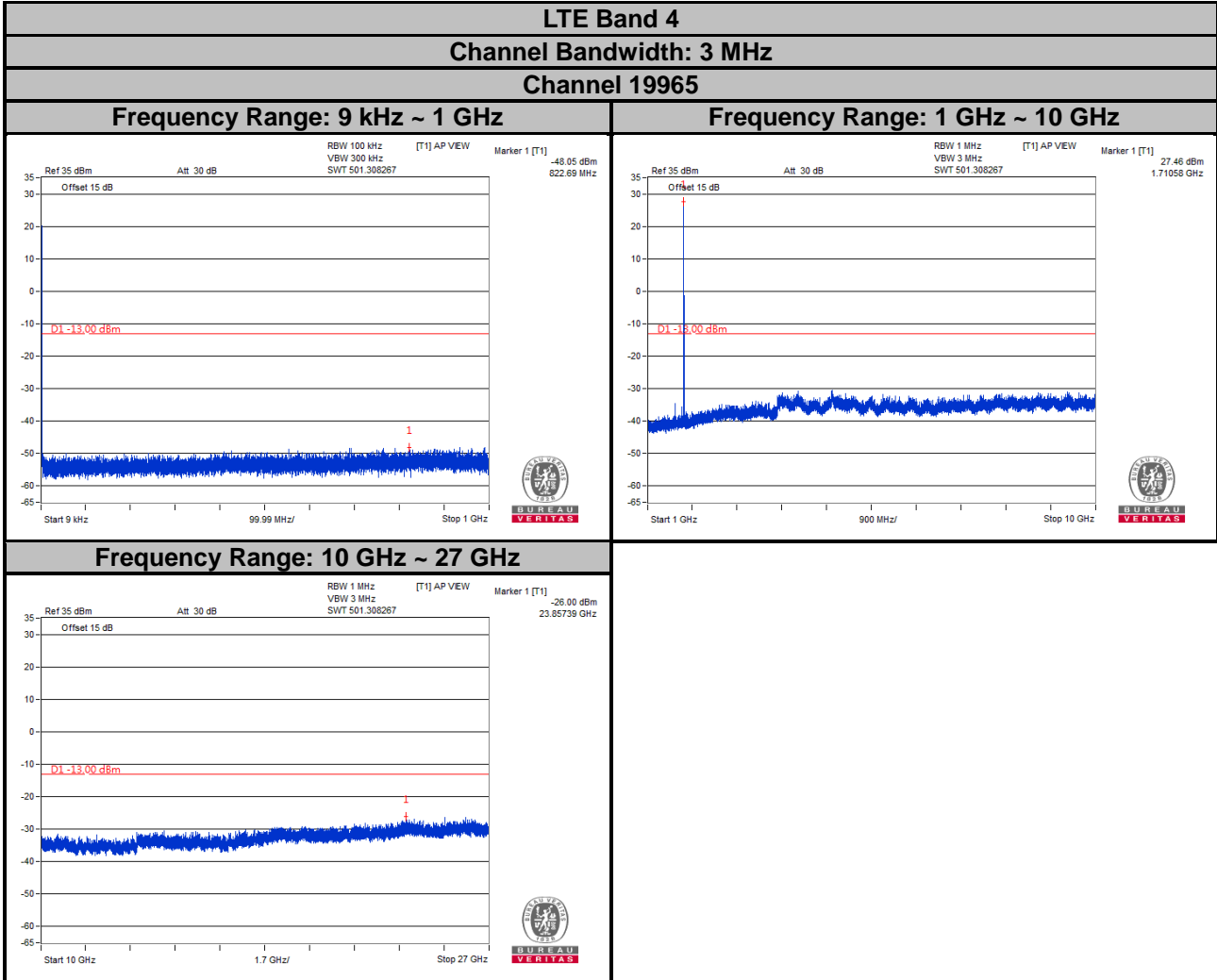

Note: The signal over the limit in 9 kHz is from spectrum analyzer.

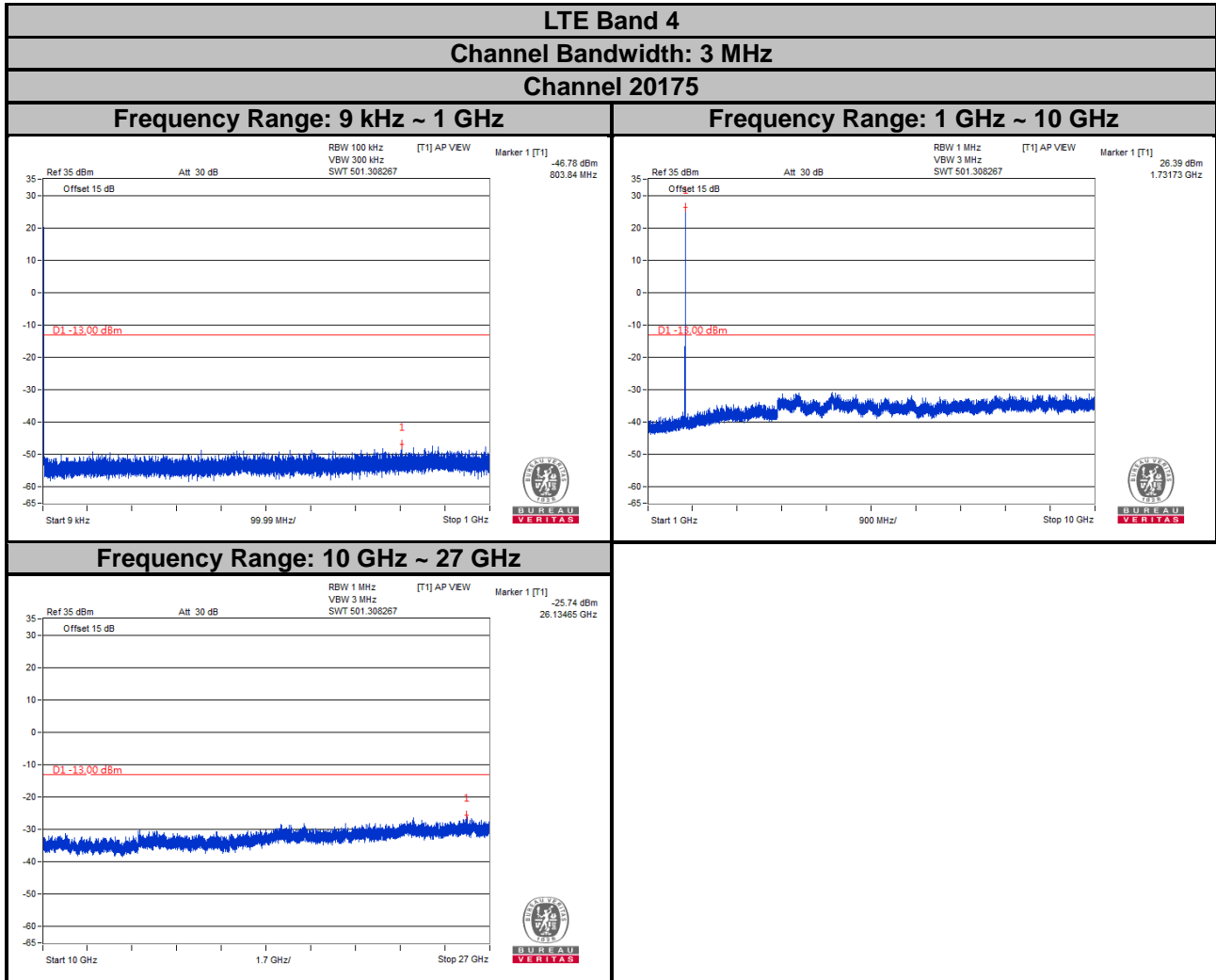

Note: The signal over the limit in 9 kHz is from spectrum analyzer.

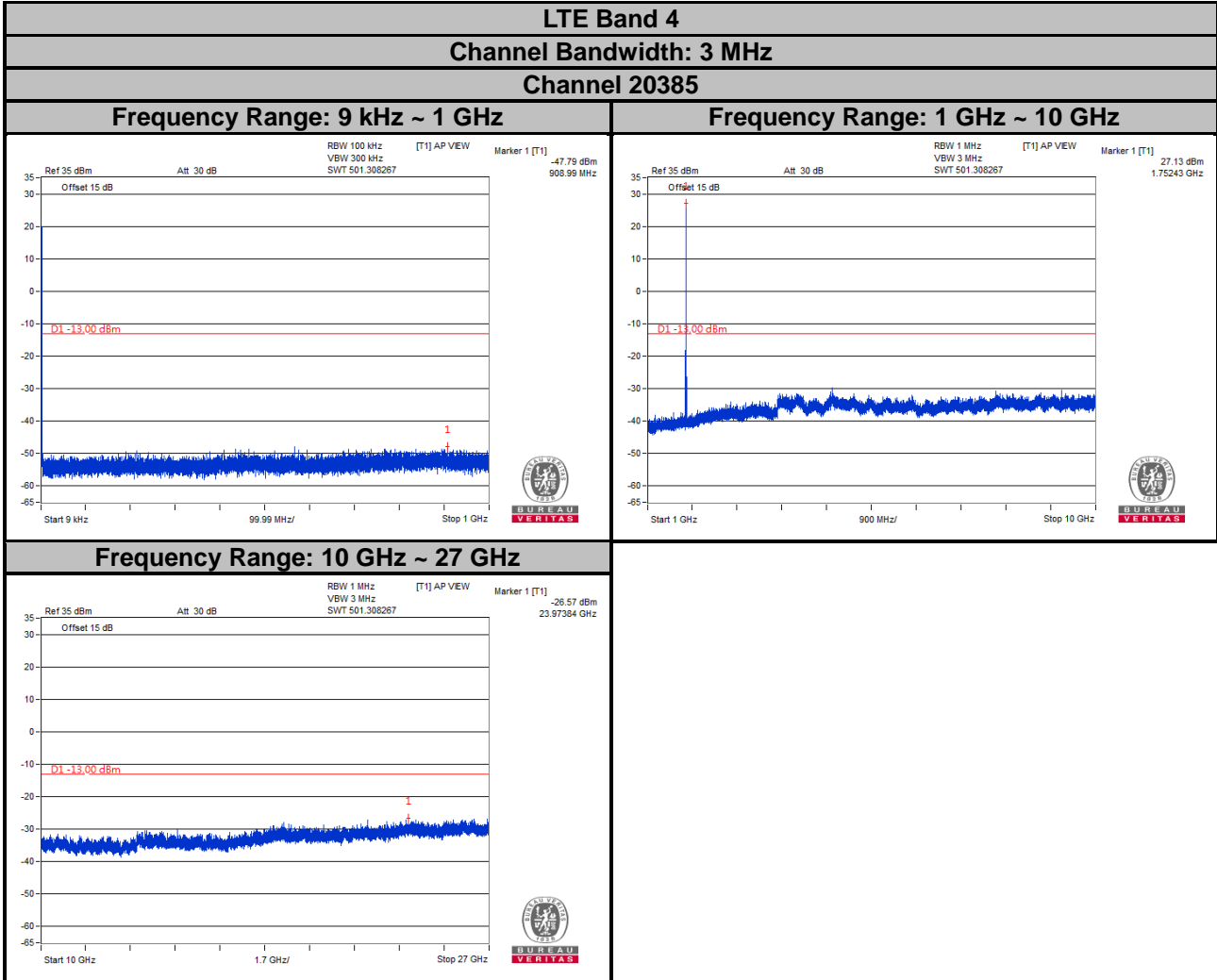

Note: The signal over the limit in 9 kHz is from spectrum analyzer.

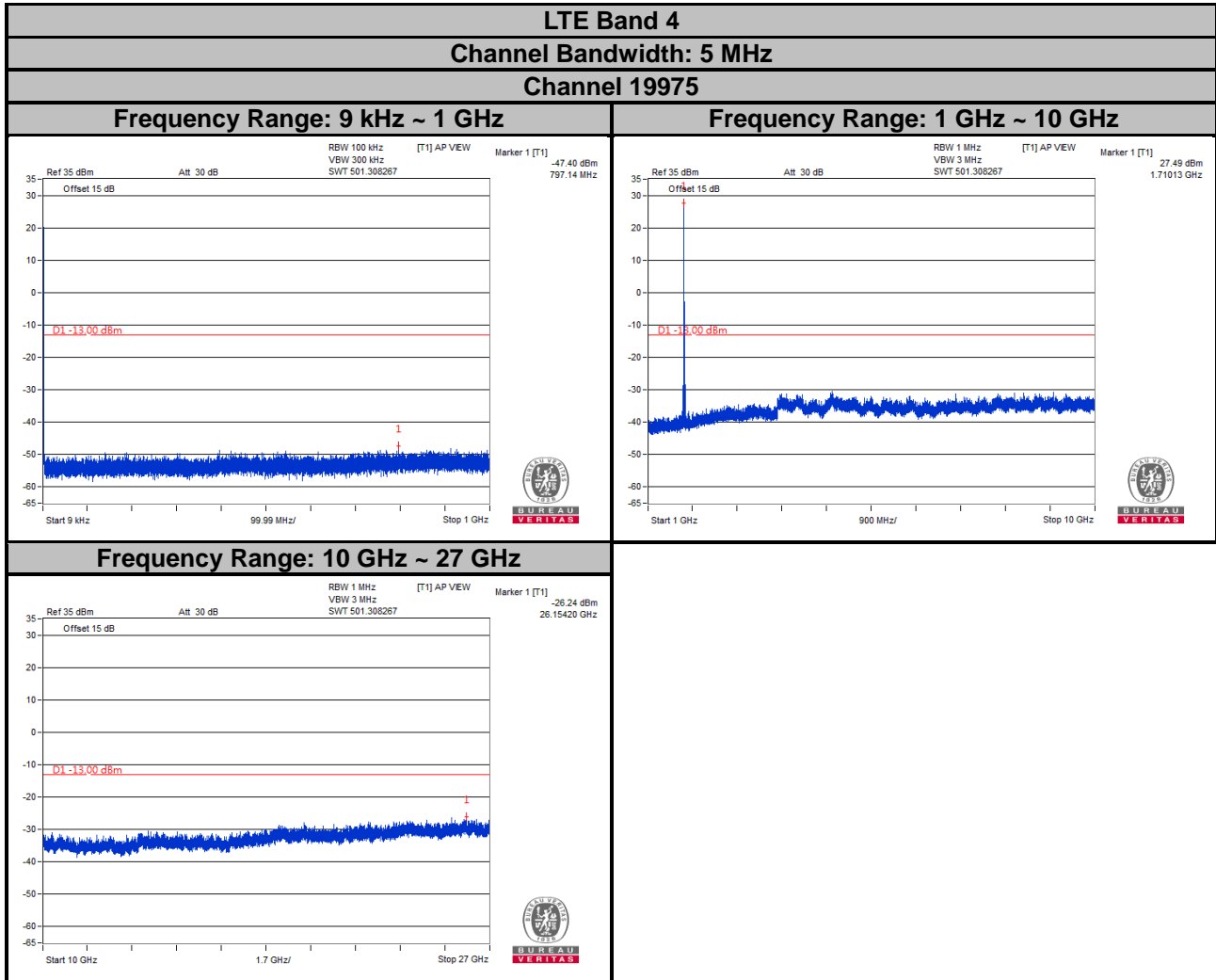

Note: The signal over the limit in 9 kHz is from spectrum analyzer.

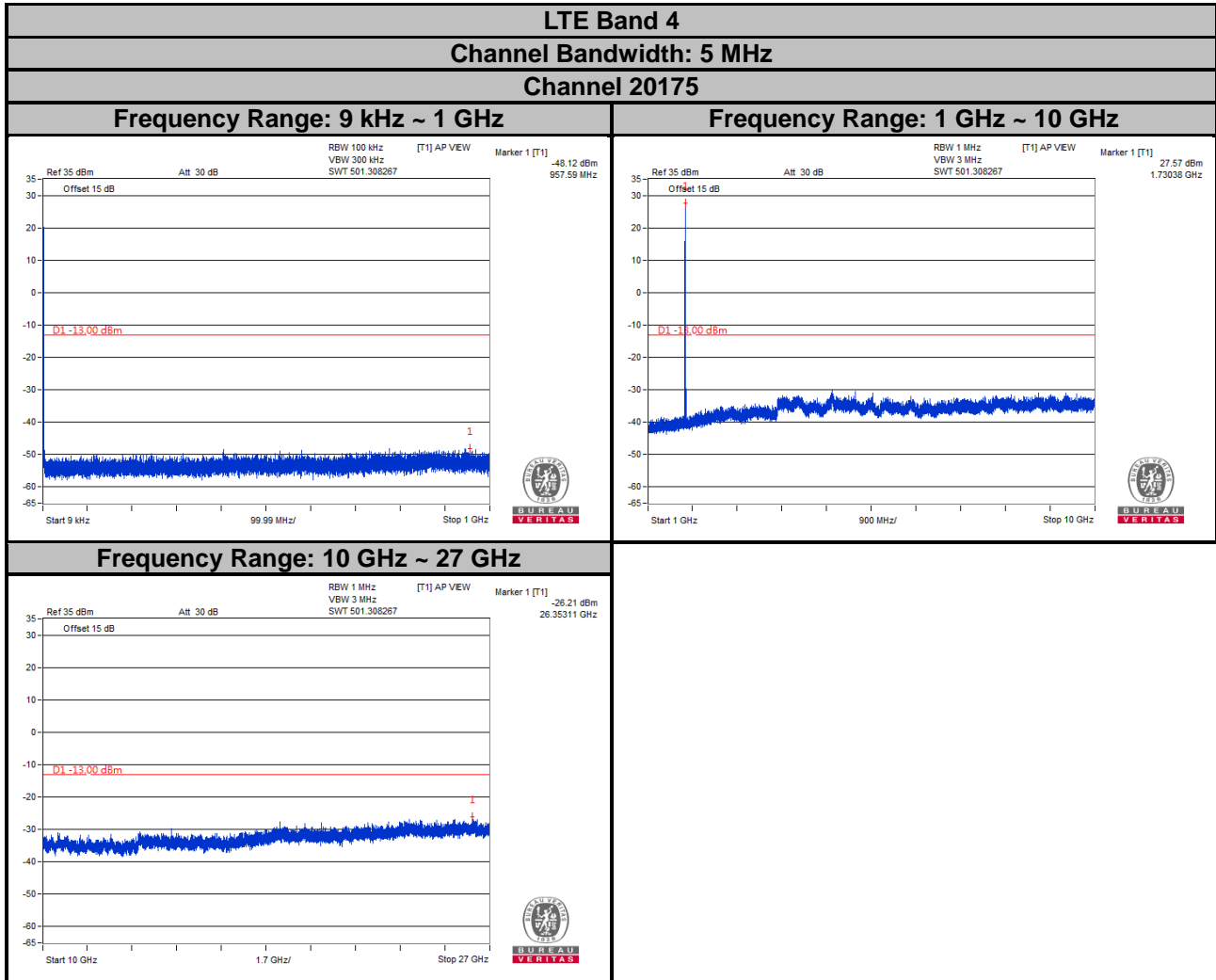

Note: The signal over the limit in 9 kHz is from spectrum analyzer.

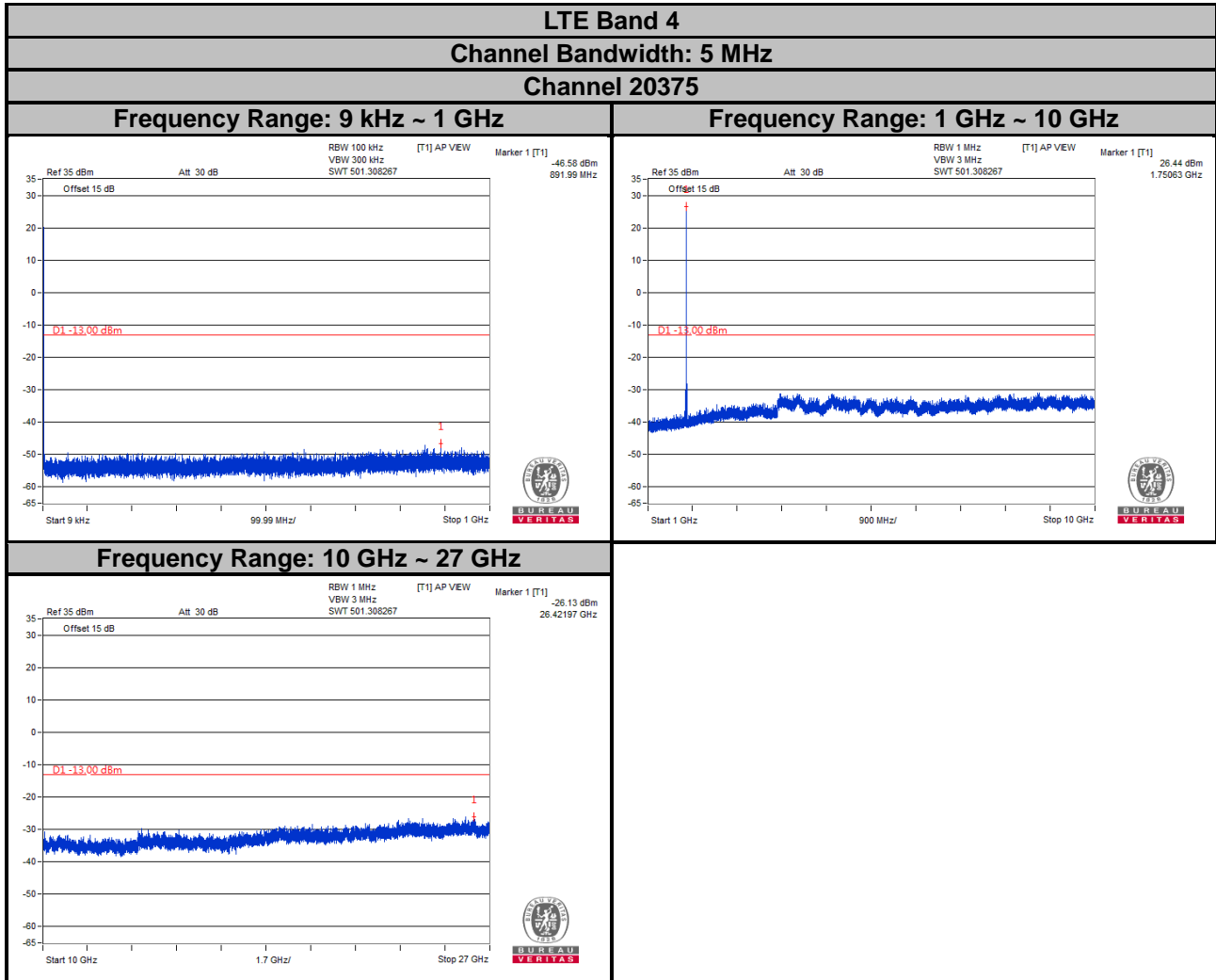

Note: The signal over the limit in 9 kHz is from spectrum analyzer.

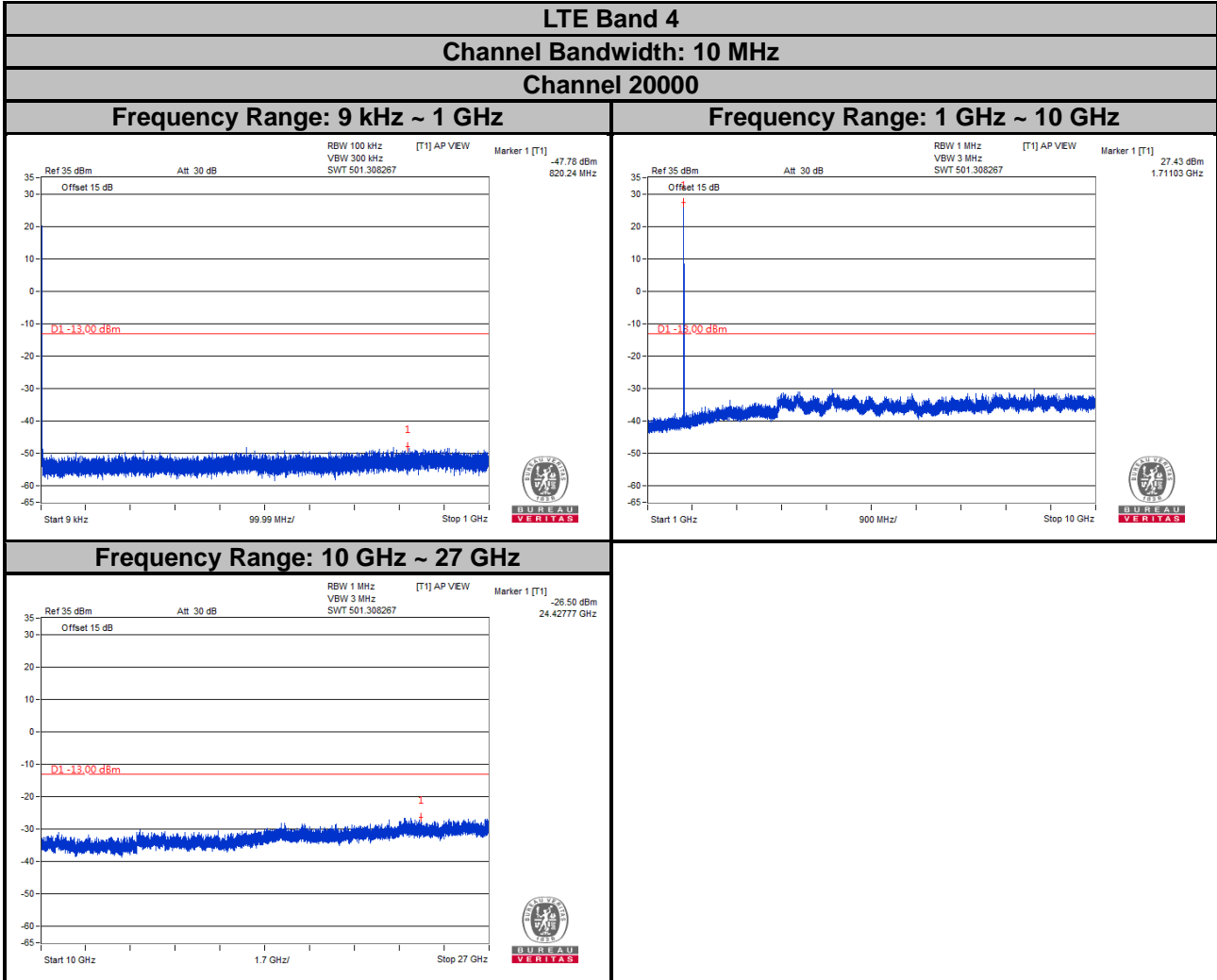

Note: The signal over the limit in 9 kHz is from spectrum analyzer.

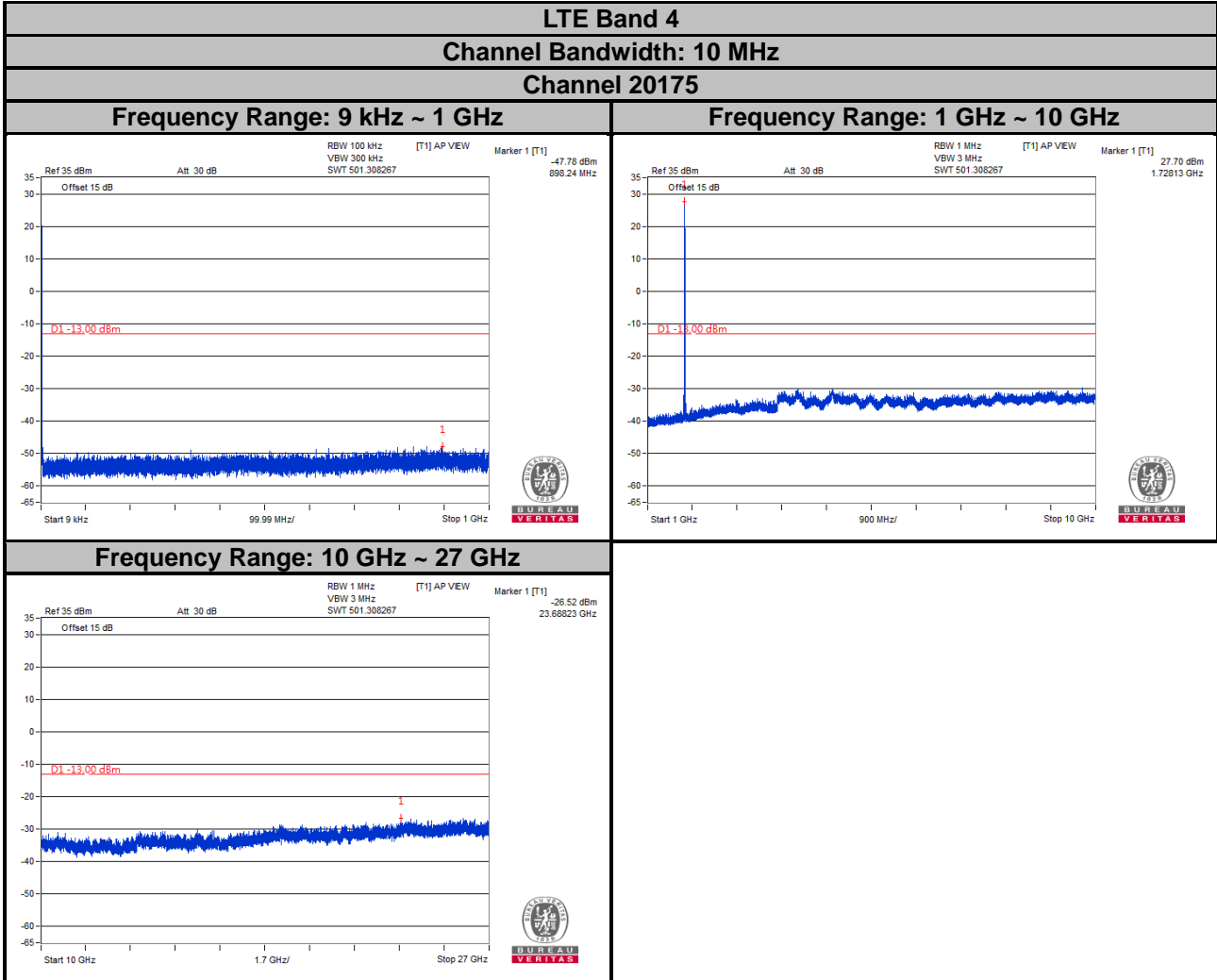

Note: The signal over the limit in 9 kHz is from spectrum analyzer.

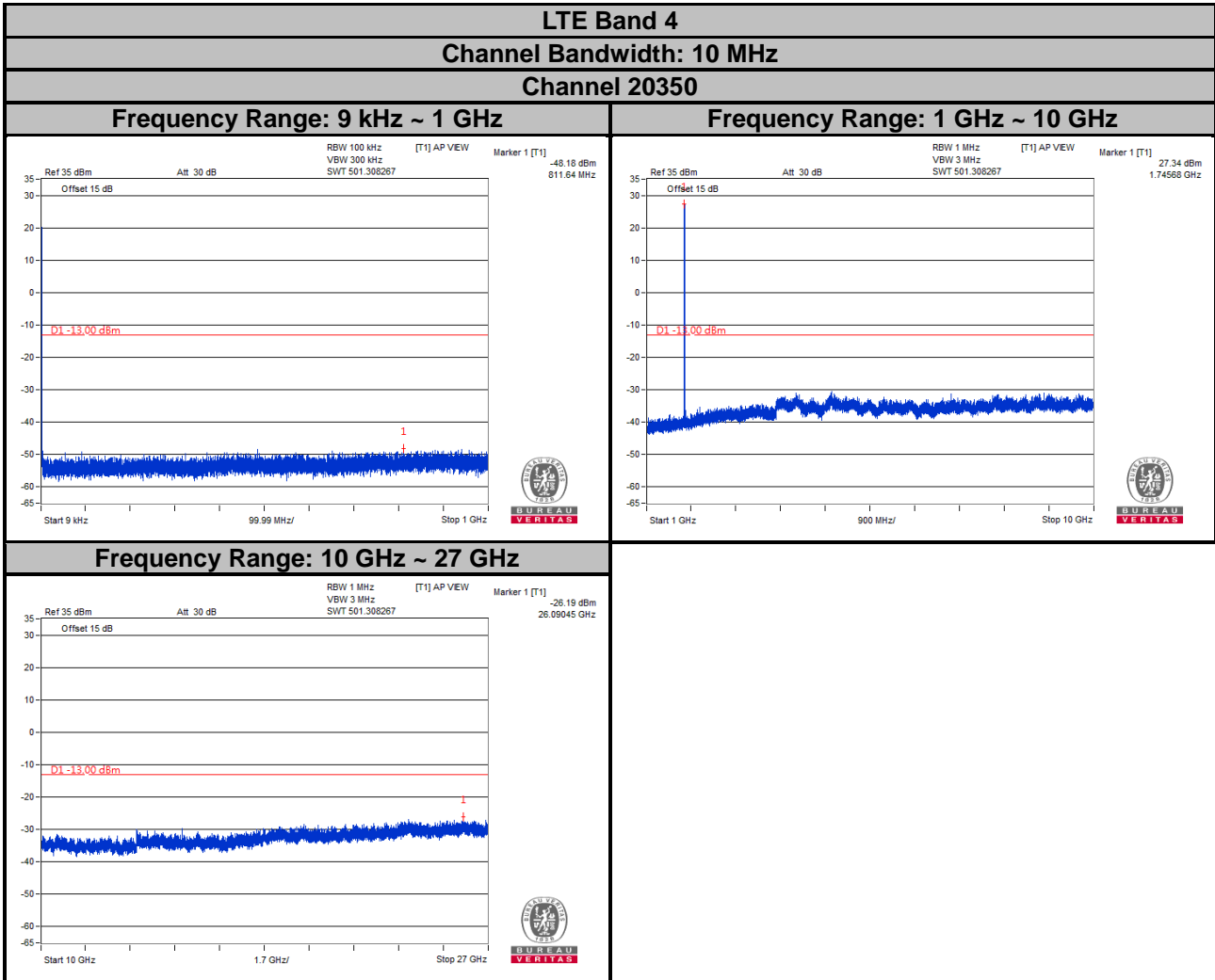

Note: The signal over the limit in 9 kHz is from spectrum analyzer.

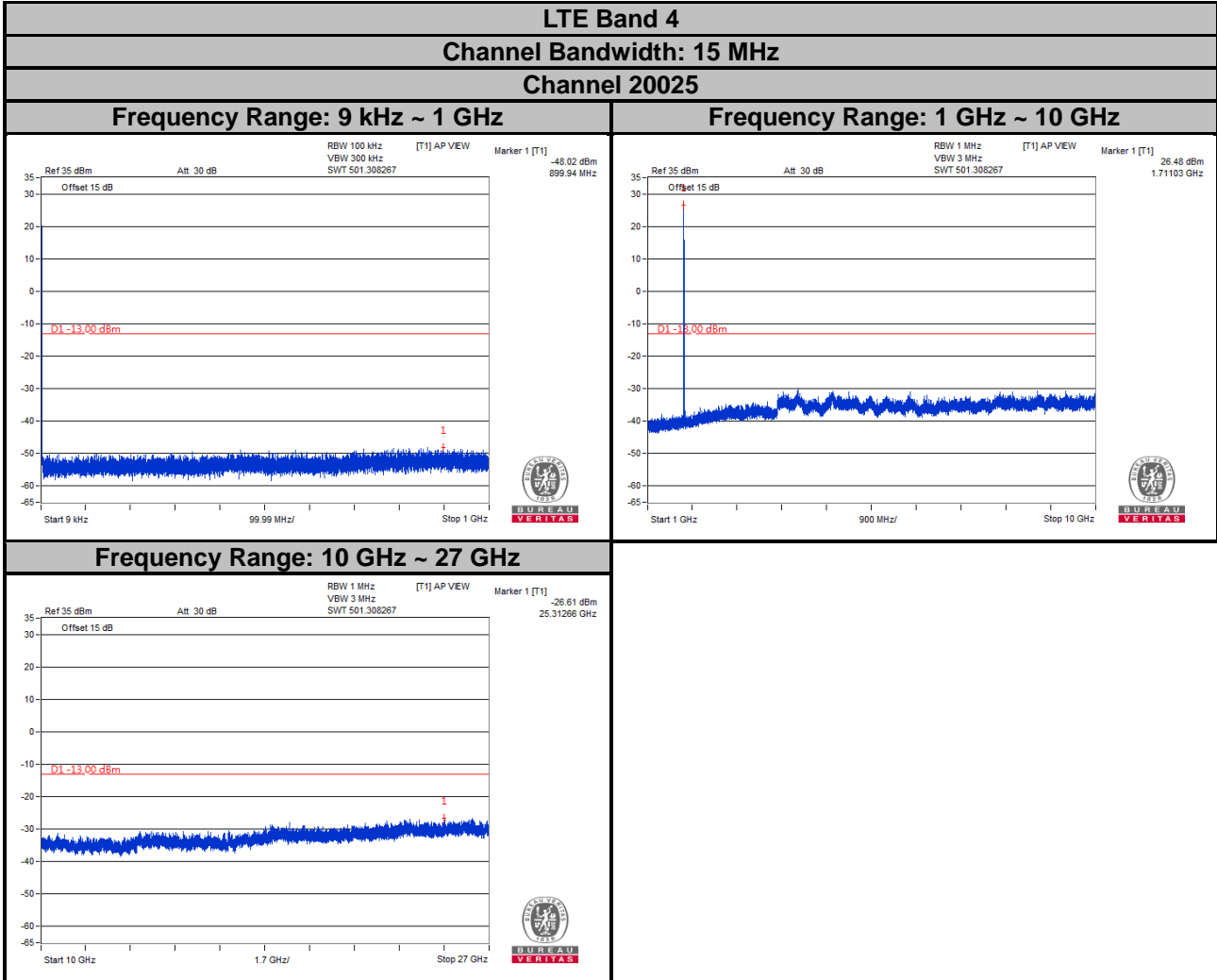

Note: The signal over the limit in 9 kHz is from spectrum analyzer.

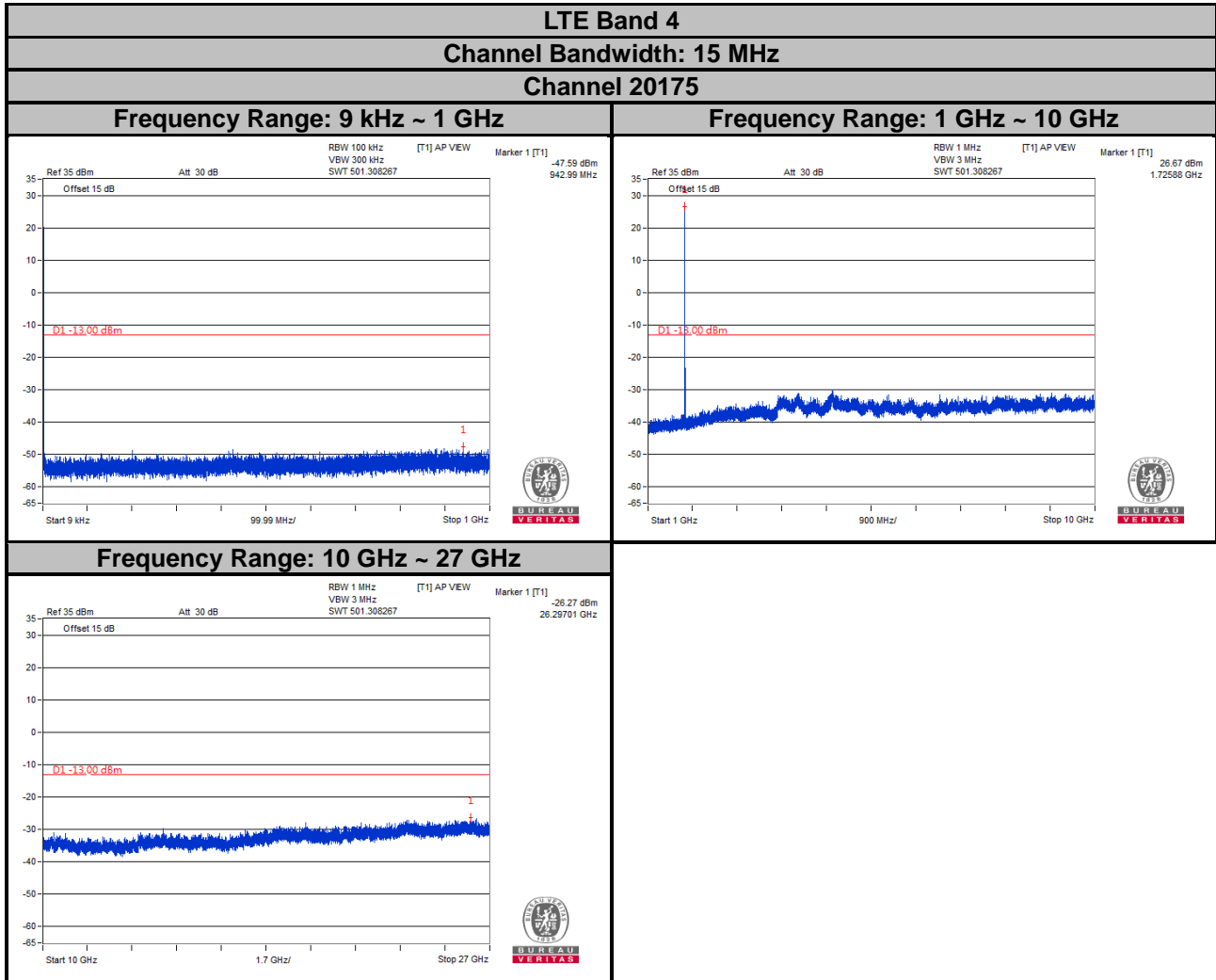

Note: The signal over the limit in 9 kHz is from spectrum analyzer.

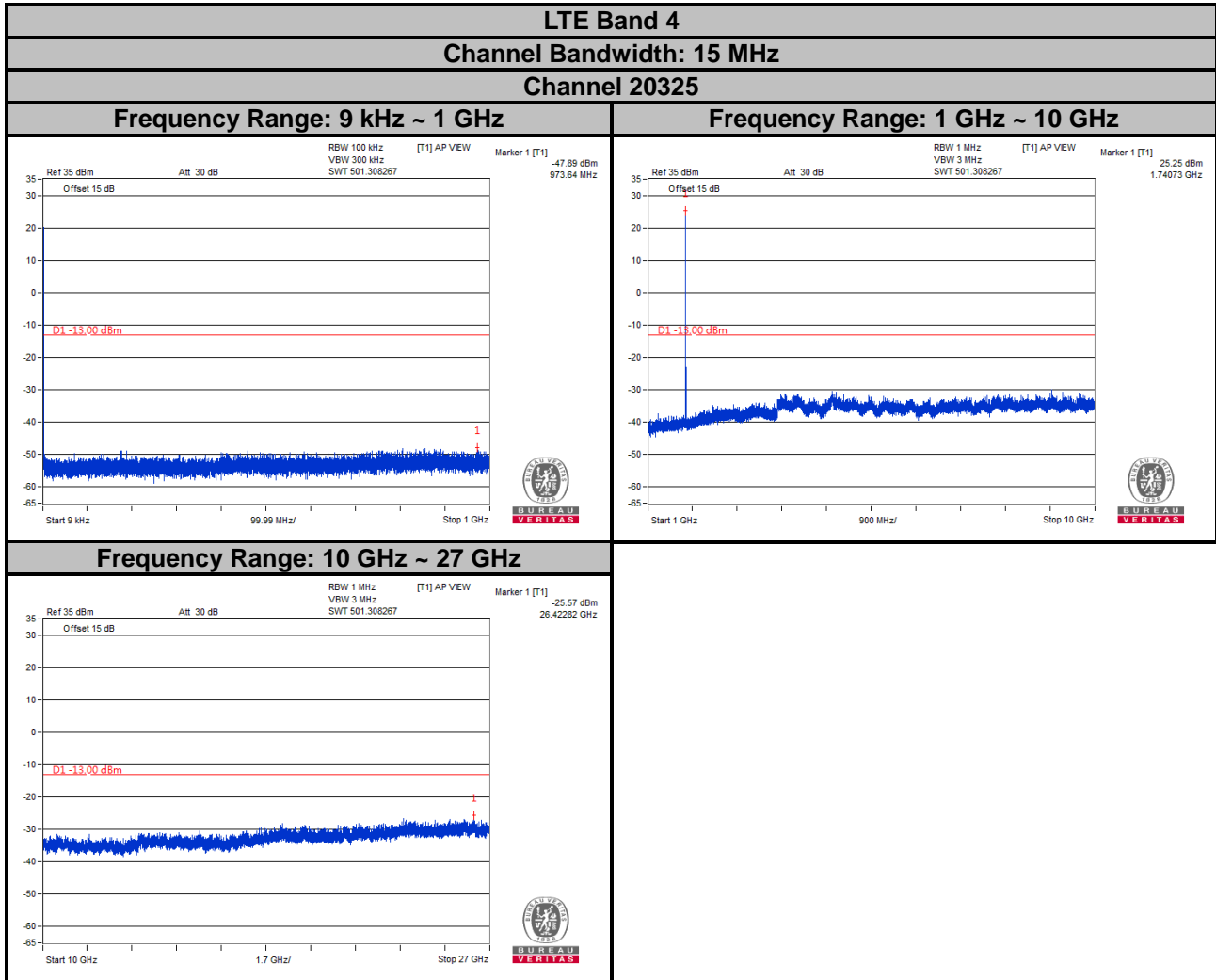

Note: The signal over the limit in 9 kHz is from spectrum analyzer.

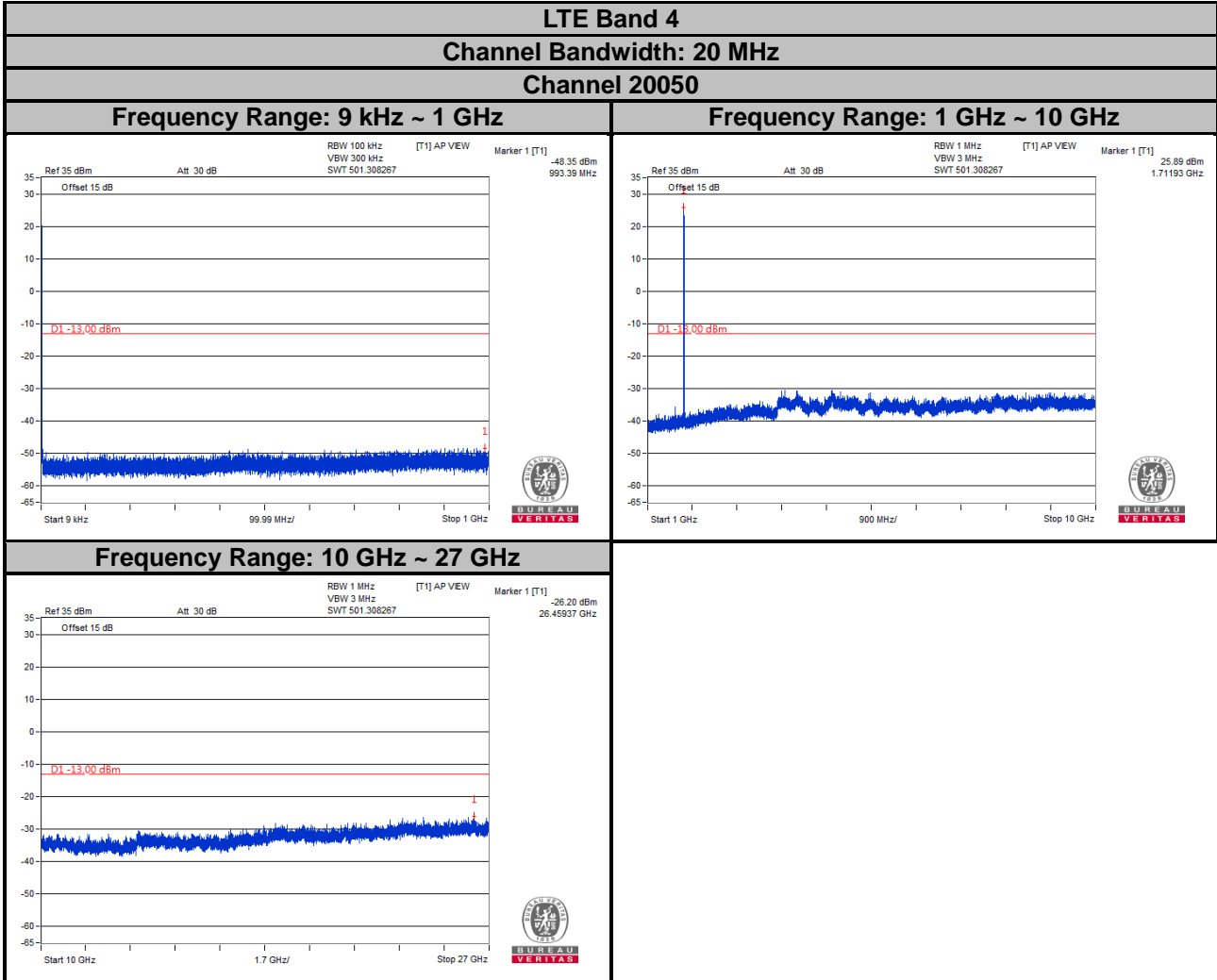

Note: The signal over the limit in 9 kHz is from spectrum analyzer.

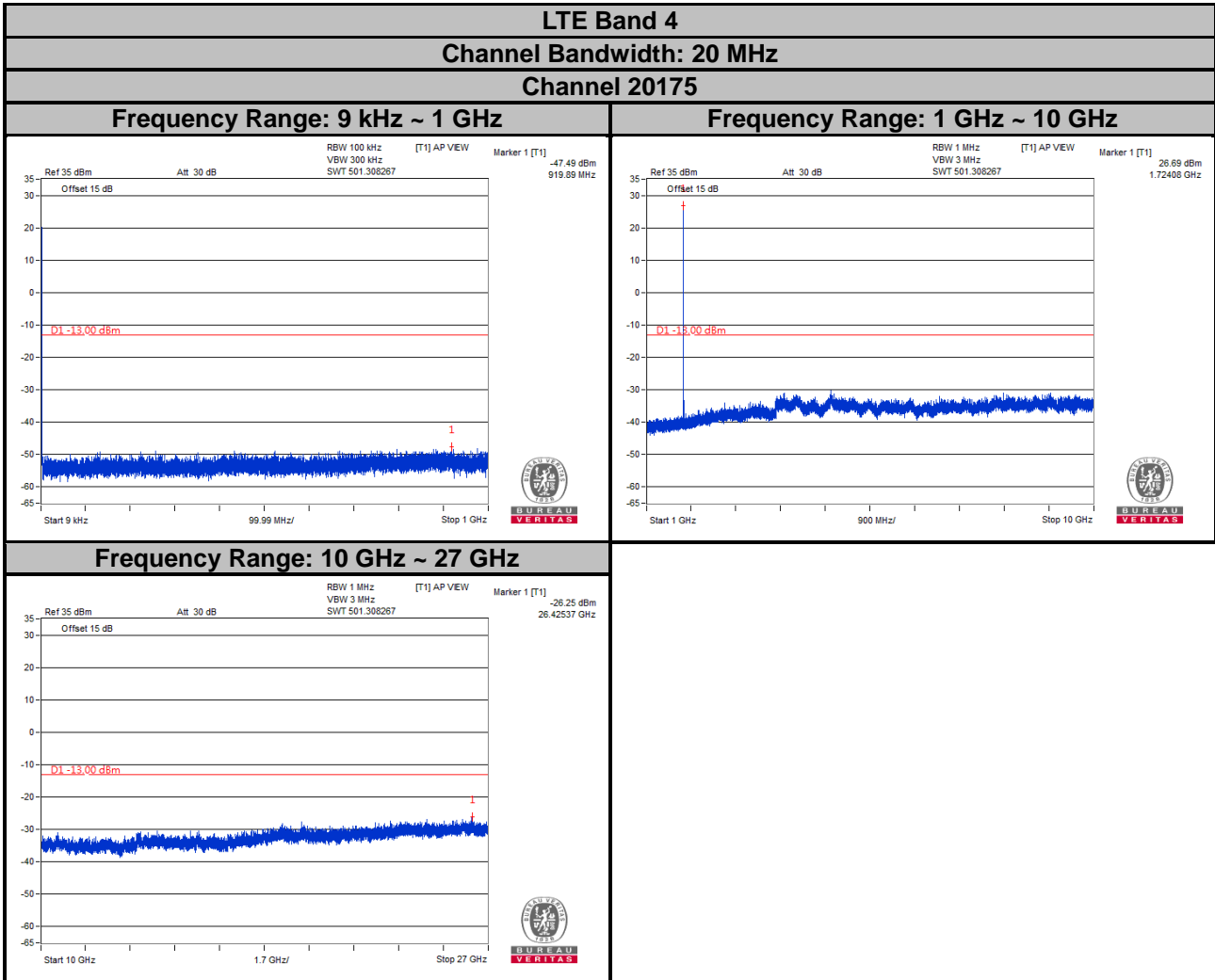

Note: The signal over the limit in 9 kHz is from spectrum analyzer.

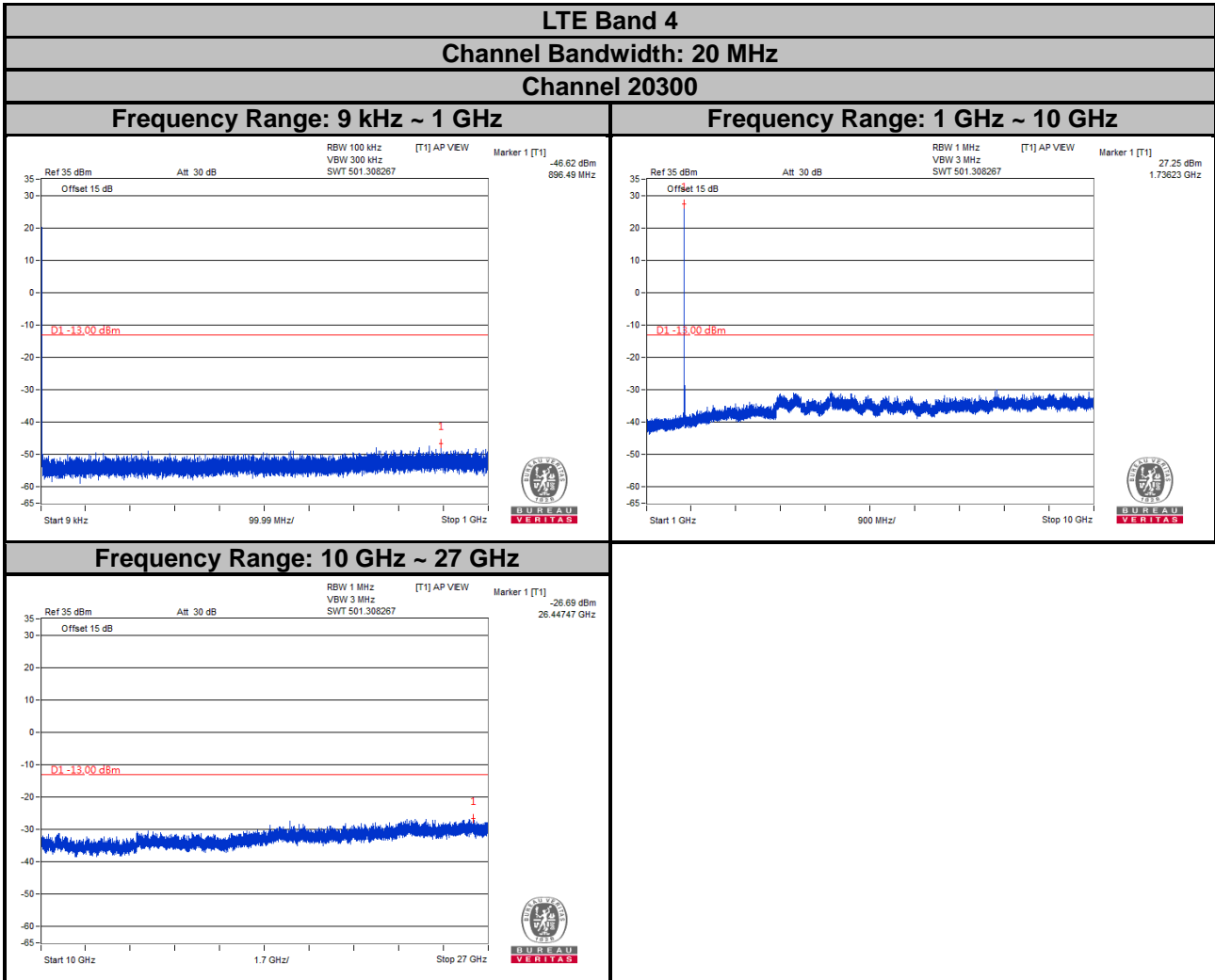

Note: The signal over the limit in 9 kHz is from spectrum analyzer.

LTE Band 12
Channel Bandwidth: 1.4 MHz
Channel 23017

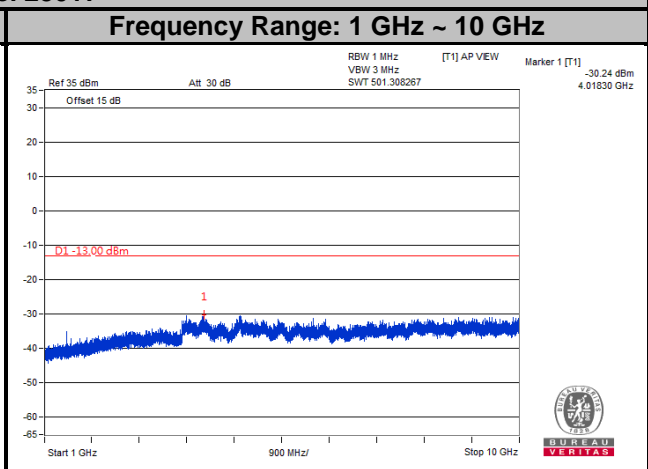
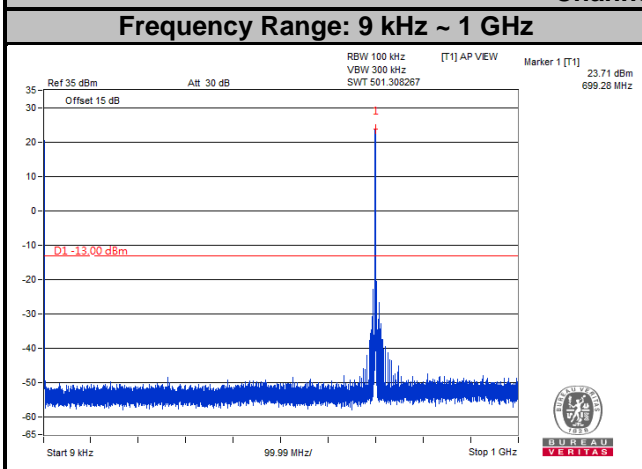

Channel 23095

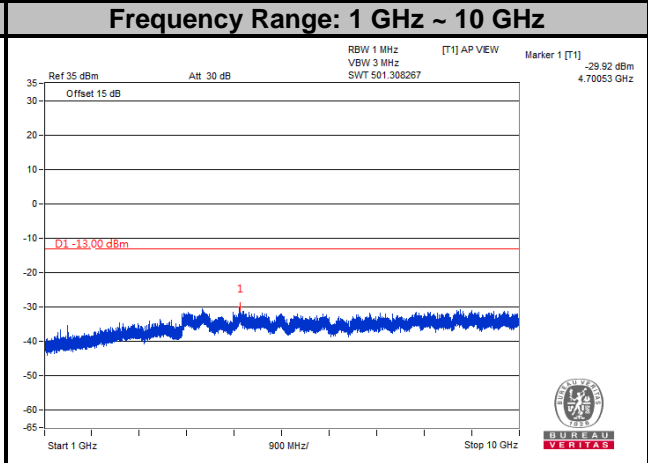
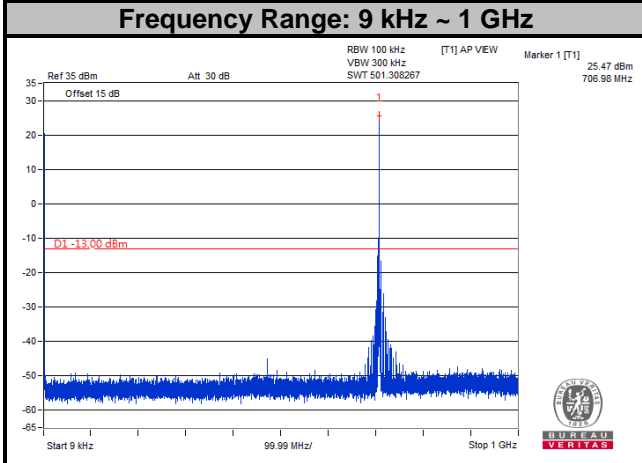

Channel 23173

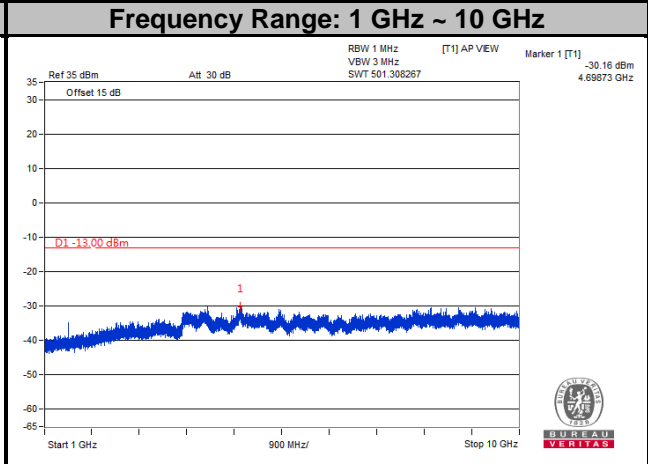
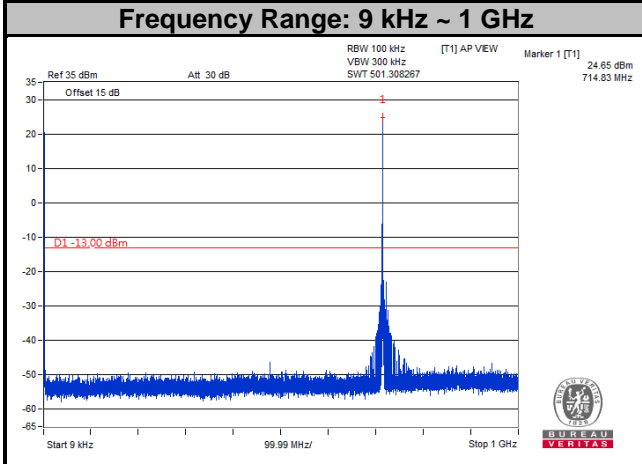

Note: The signal over the limit in 9 kHz is from spectrum analyzer.

LTE Band 12
Channel Bandwidth: 3 MHz

Channel 23025

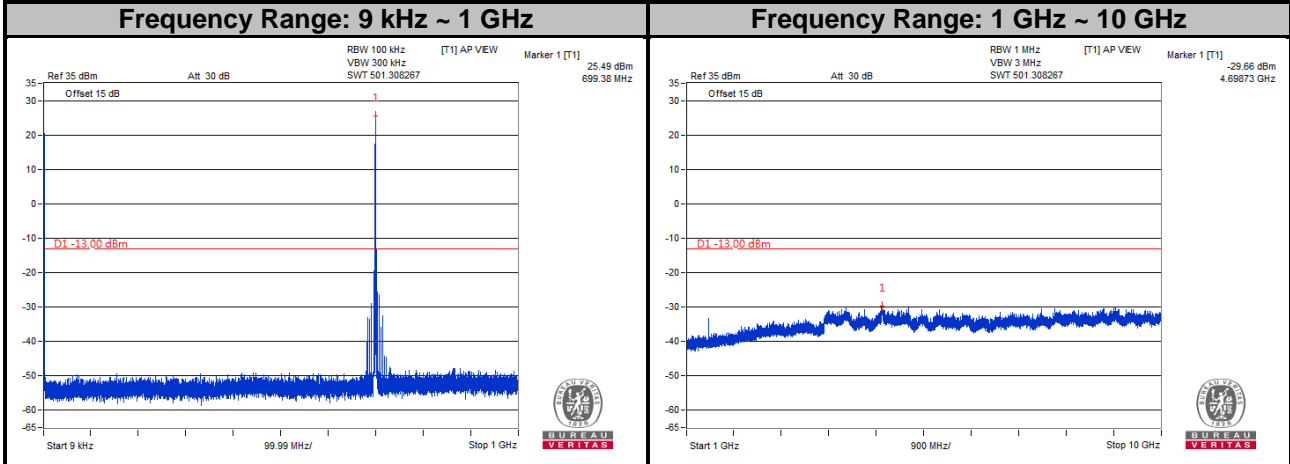

Channel 23095

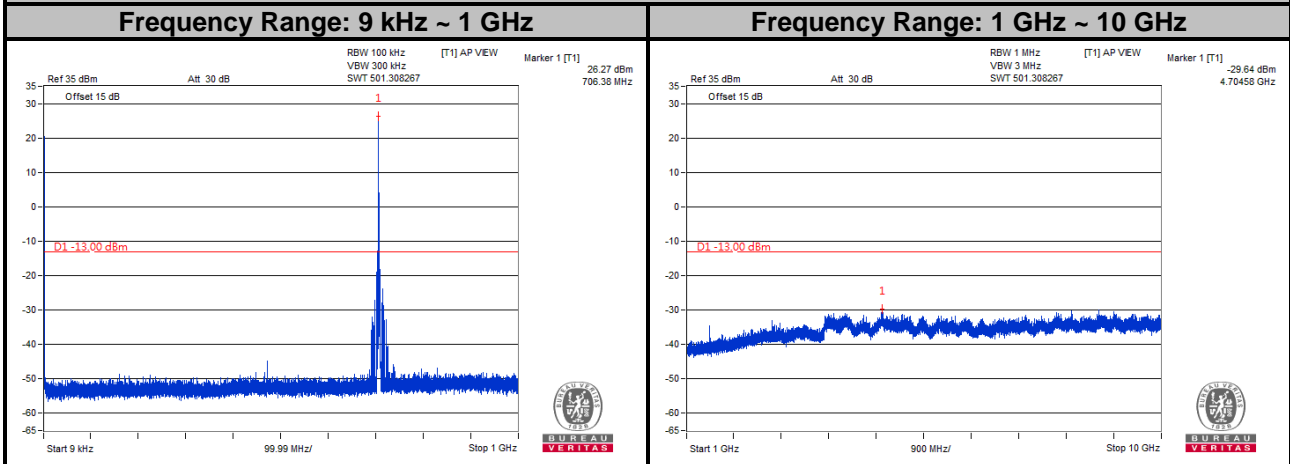

Channel 23165

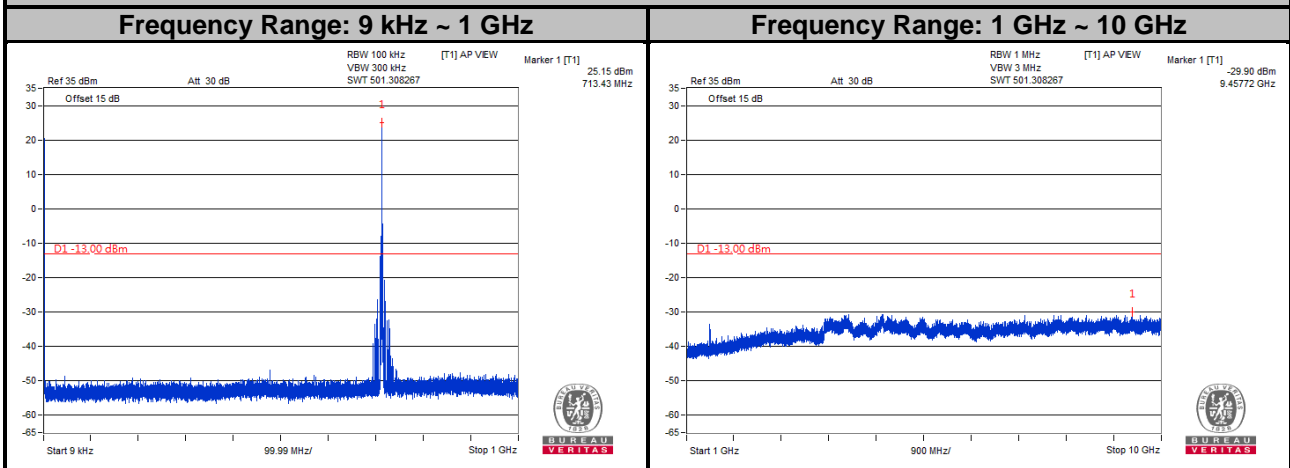

Note: The signal over the limit in 9 kHz is from spectrum analyzer.

LTE Band 12
Channel Bandwidth: 5 MHz

Channel 23035

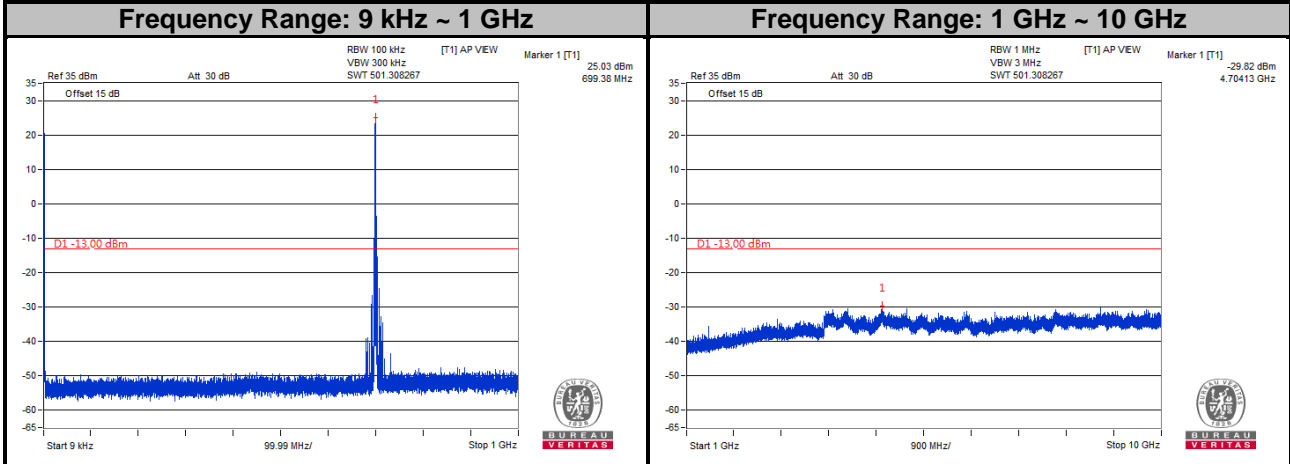

Channel 23095

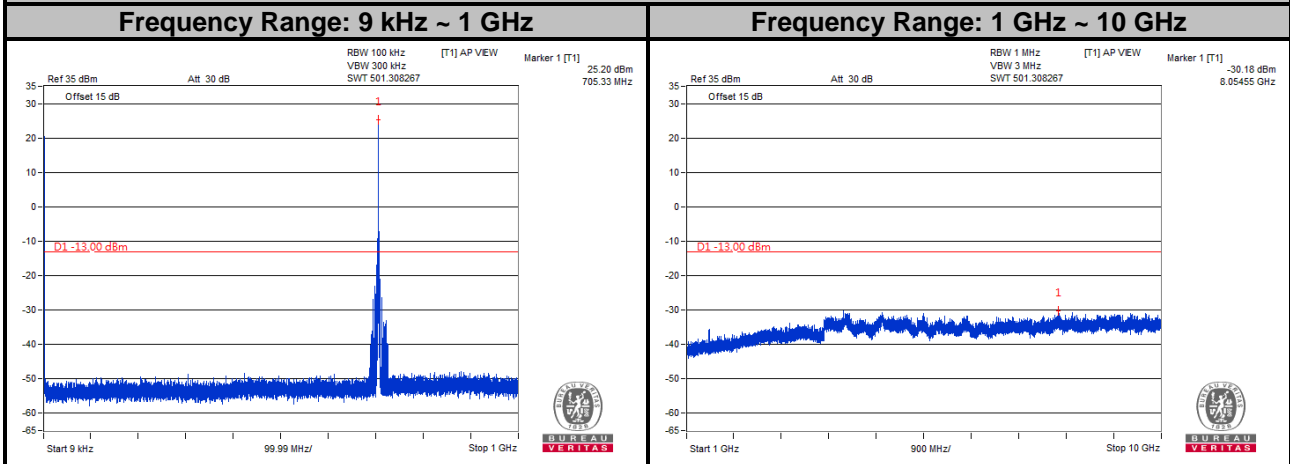

Channel 23155

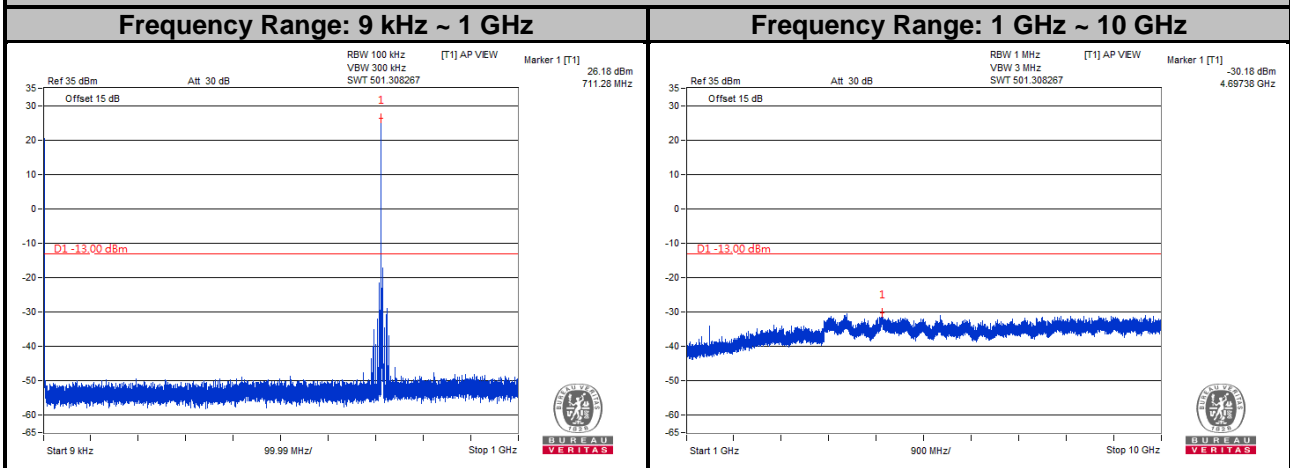

Note: The signal over the limit in 9 kHz is from spectrum analyzer.

LTE Band 12
Channel Bandwidth: 10 MHz
Channel 23060

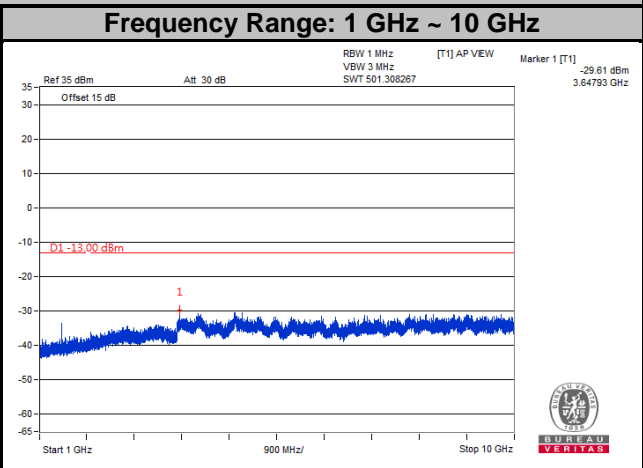
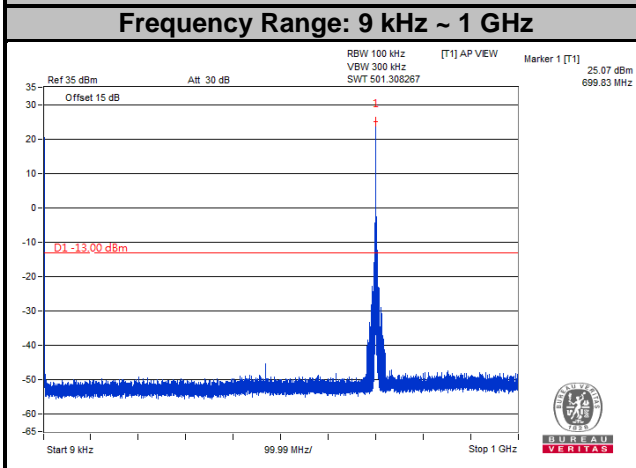

Channel 23095

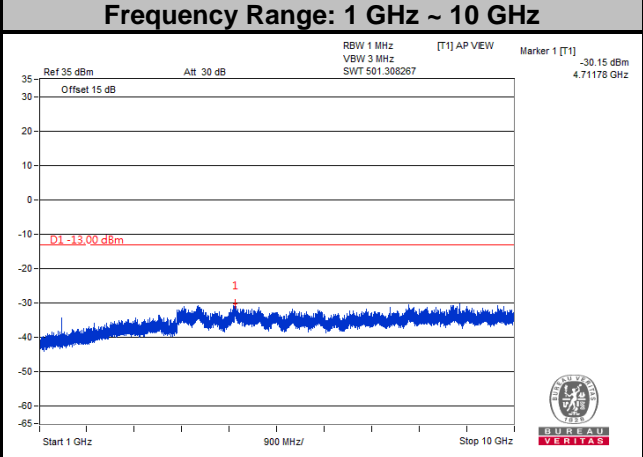
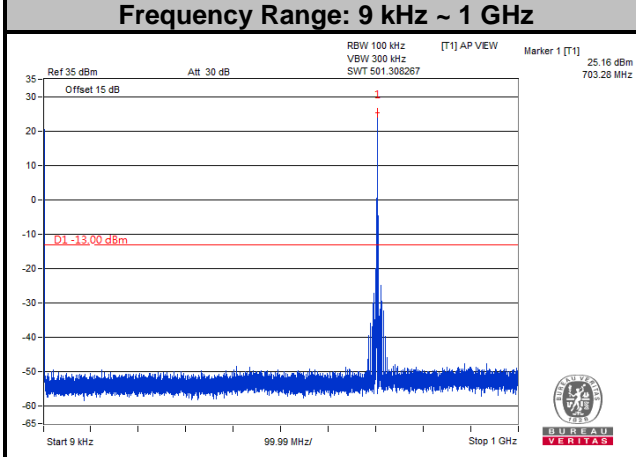

Channel 23130

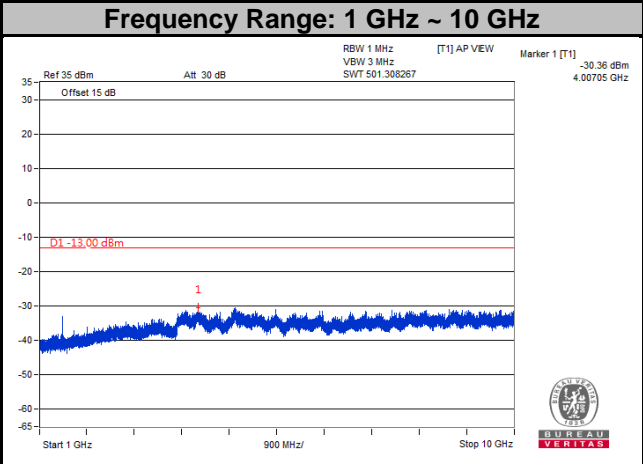
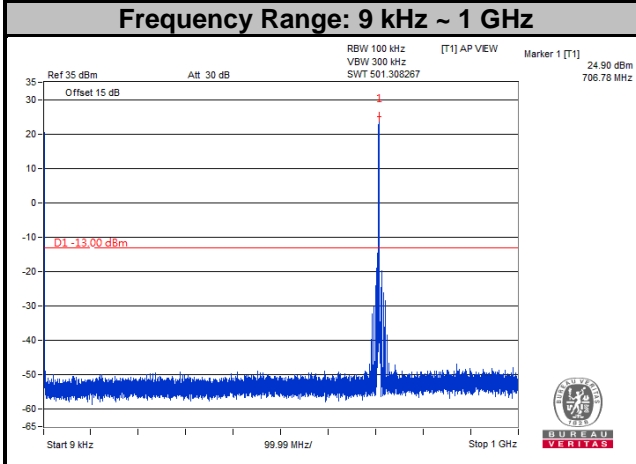

Note: The signal over the limit in 9 kHz is from spectrum analyzer.

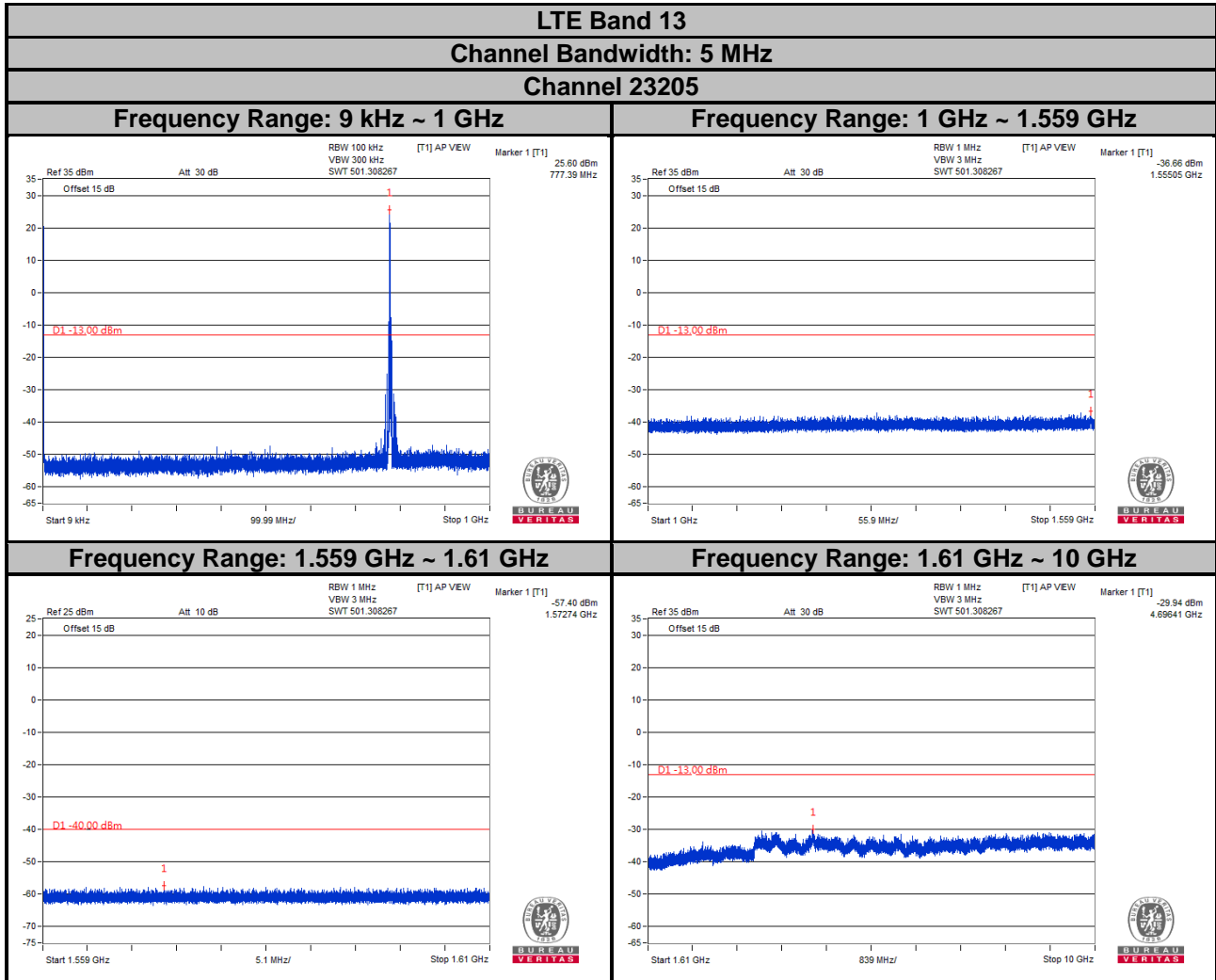

Note: The signal over the limit in 9 kHz is from spectrum analyzer.

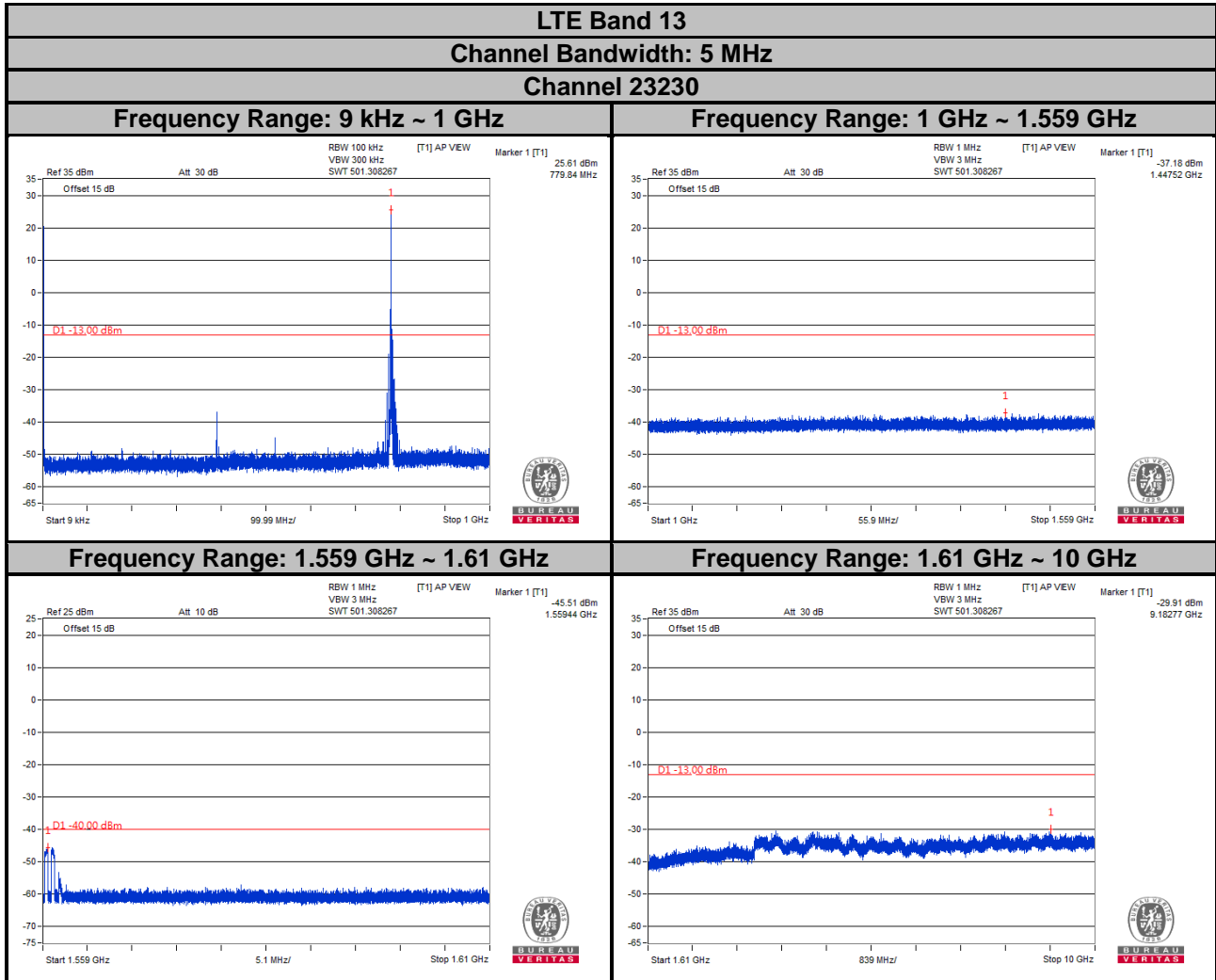

Note: The signal over the limit in 9 kHz is from spectrum analyzer.

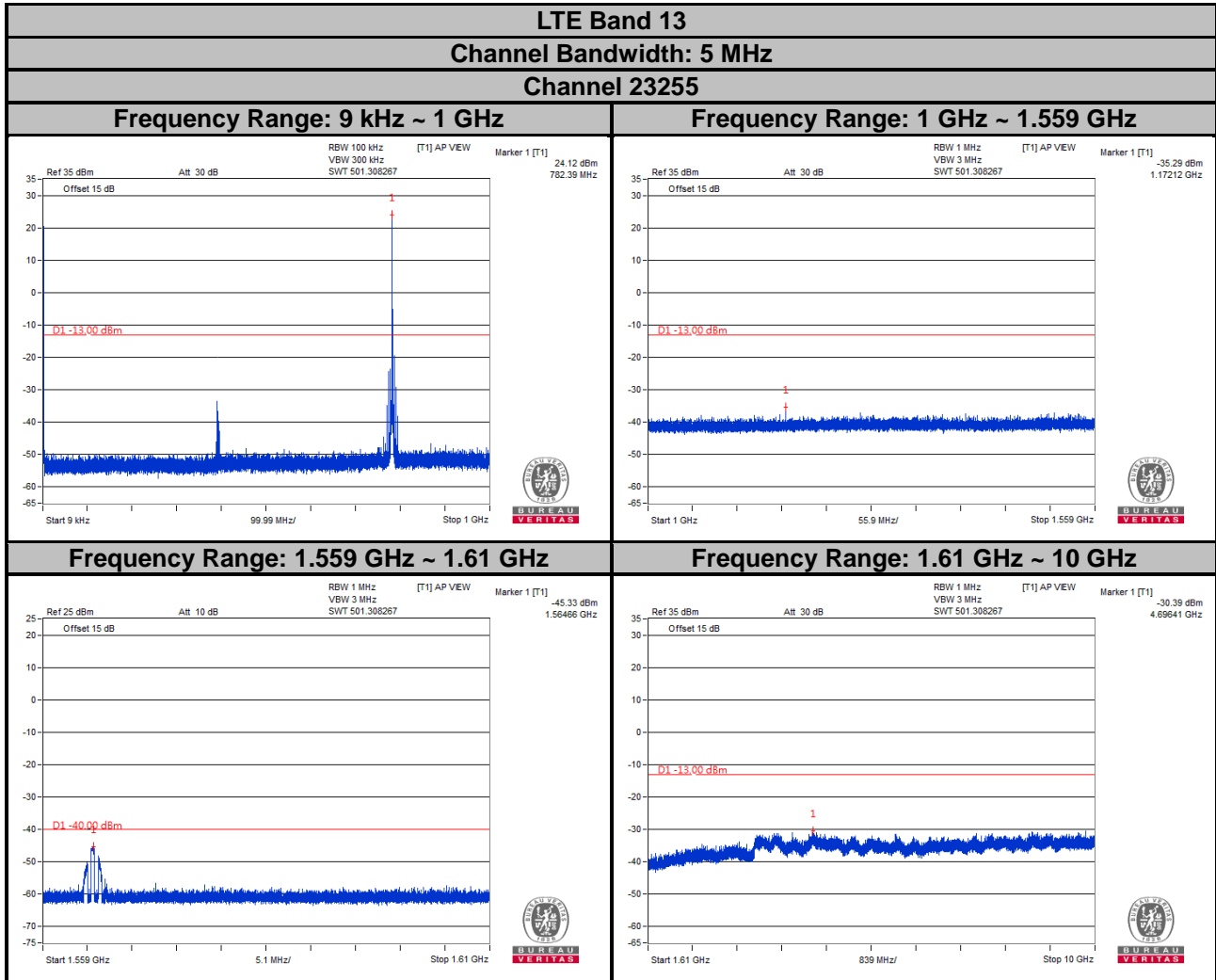

Note: The signal over the limit in 9 kHz is from spectrum analyzer.

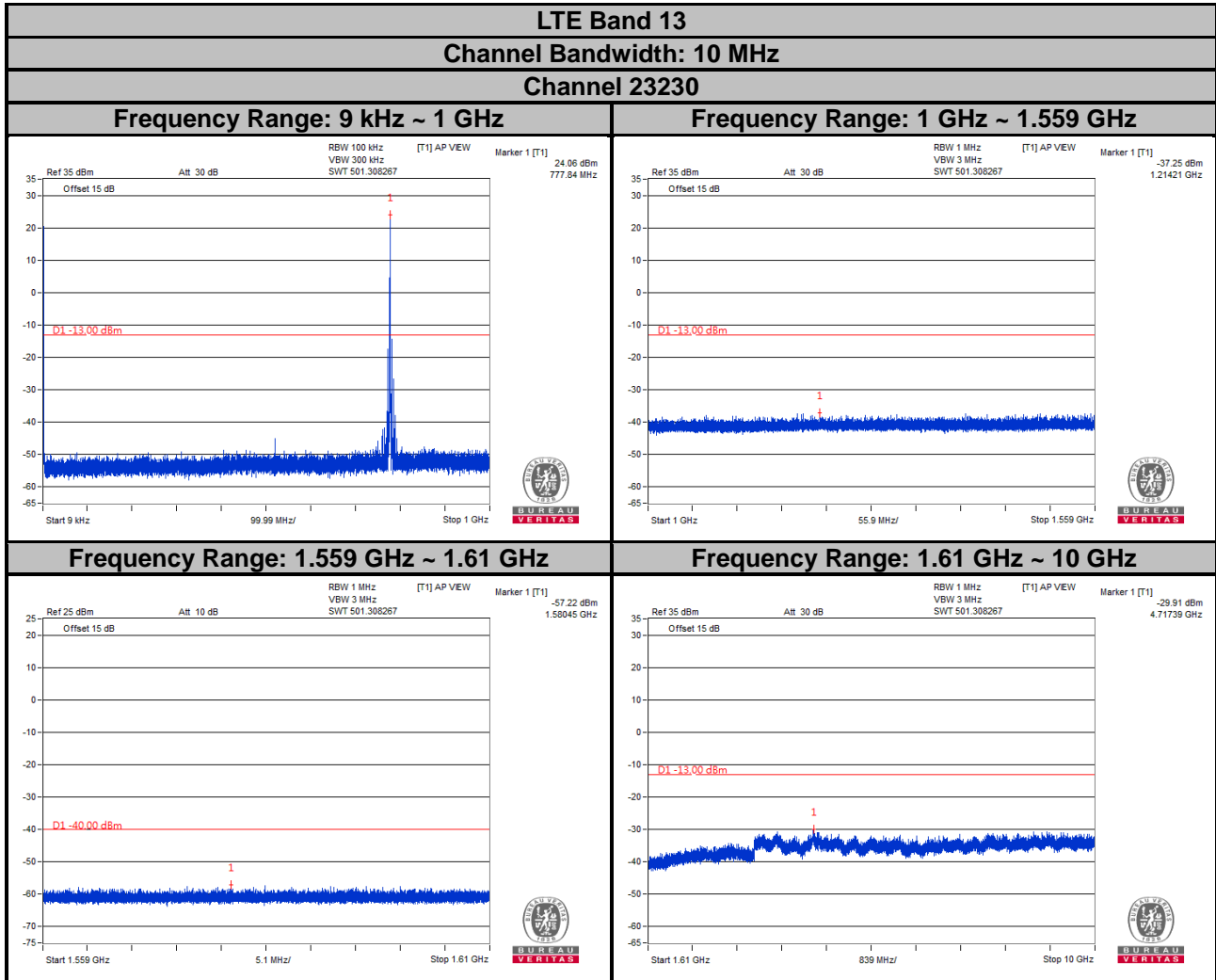

Note: The signal over the limit in 9 kHz is from spectrum analyzer.

4.8 Radiated Emission Measurement

4.8.1 Limits of Radiated Emission Measurement

- a. The power of any emission outside a licensee's frequency block shall be attenuated below the transmitter power (P) by at least $43 + 10 \log (P)$ dB. The limit of emission is equal to -13 dBm.
- b. For operations in the 775-788 MHz, emissions in the band 1559-1610 MHz shall be limited to -70 dBW/MHz. The limit of emissions is equal to -40 dBm.

4.8.2 Test Procedure

- a. Substitution method is used for E.I.R.P measurement. In the semi-anechoic chamber, EUT placed on the 0.8 m (below or equal 1 GHz) and/or 1.5 m (above 1 GHz) height of Turn Table, rotated the table around 360 degrees to search the maximum radiation power and receiver antenna shall be rotated vertical and horizontal polarization and moved height from 1 m to 4 m to find the maximum polar radiated power. The "Read Value" is the spectrum reading the maximum power value.
- b. The substitution horn antenna is substituted for EUT at the same position and signals generator export the CW signal to the substitution antenna via a TX cable. Rotated the Turn Table and moved receiving antenna to find the maximum radiation power. Adjust output power level of S.G to get a Value of spectrum reading equal to "Read Value" of step a. Record the power level of S.G.
- c. $EIRP = \text{Output power level of S.G} - \text{TX cable loss} + \text{Antenna gain of substitution horn}$.
- d. E.R.P power can be calculated form E.I.R.P power by subtracting the gain of dipole, $E.R.P \text{ power} = E.I.R.P \text{ power} - 2.15 \text{ dB}$.

Note: The resolution bandwidth of spectrum analyzer is 1 MHz and the video bandwidth is 3 MHz.

4.8.3 Deviation from Test Standard

No deviation.

4.8.4 Test Setup

<Radiated Emission below or equal 1 GHz>

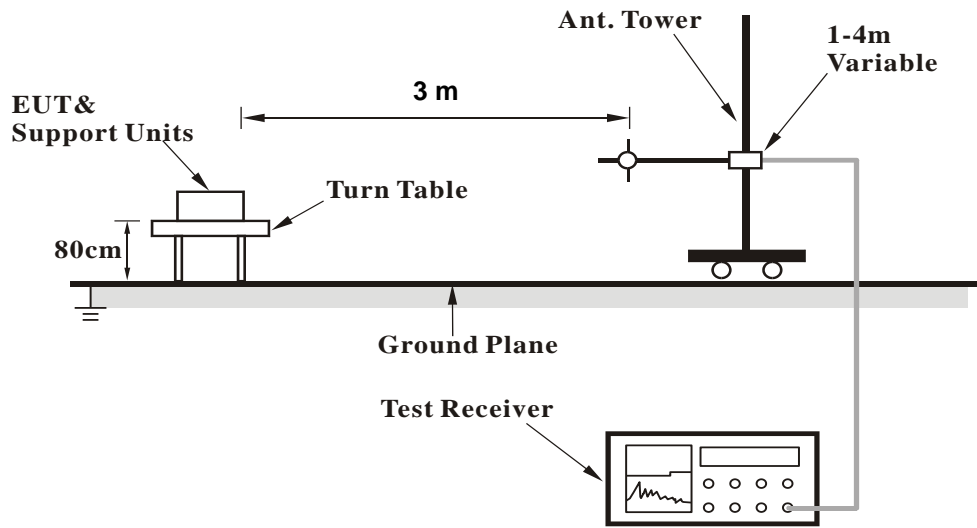

<Radiated Emission above 1 GHz>

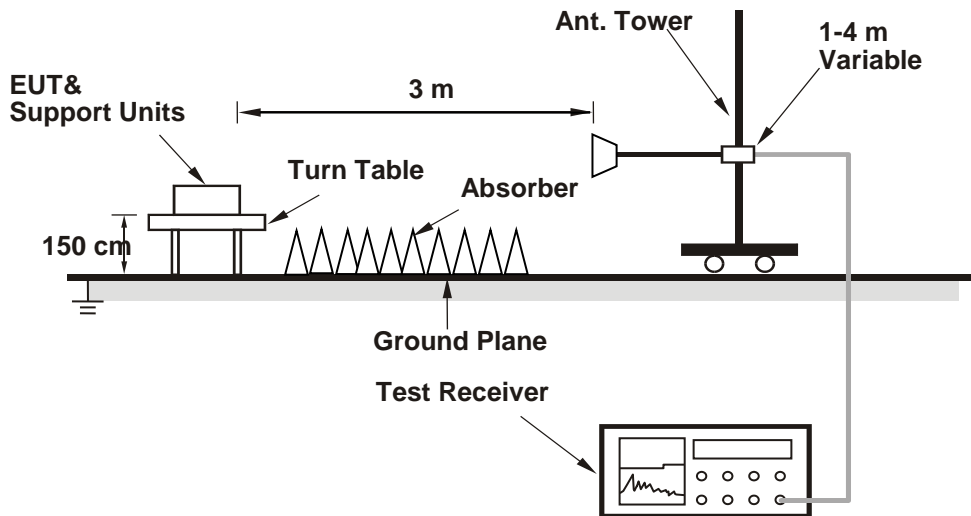

For the actual test configuration, please refer to the attached file (Test Setup Photo).

4.8.5 Test Results

LTE Band 4

Channel Bandwidth: 1.4 MHz / QPSK

Low Channel

Bureau Veritas Consumer Products Services Ltd., Taoyuan



A D T

Data: 1

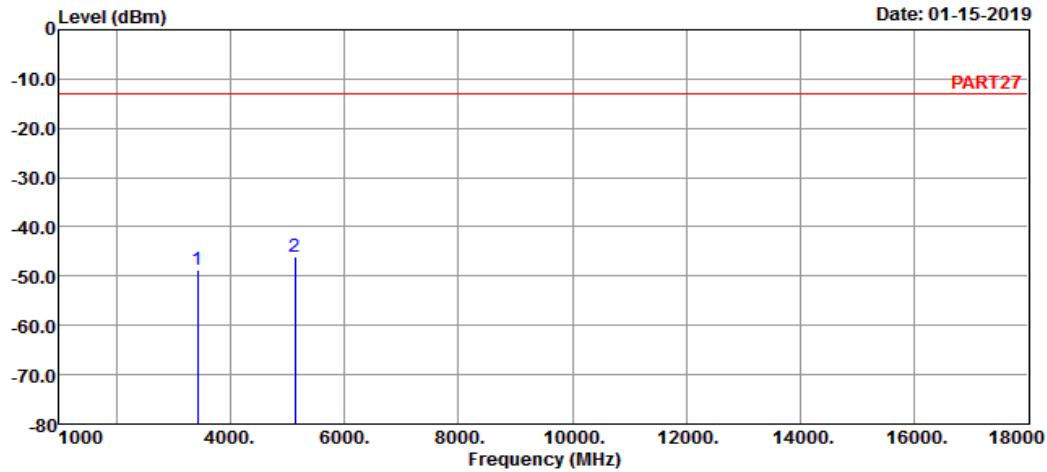

Site : 966 Chamber 5
 Condition: PART27 HORIZONTAL
 Remak : Cat-M1 Band 4 QPSK_1.4M Link_L-CH
 Tested by: Thomas Wei

	Freq	Level	Read Level	Limit Line	Over Limit	Factor	Remark
	MHz	dBm	dBm	dBm	dB	dB	
1	3421.40	-48.57	-40.23	-13.00	-35.57	-8.34	Peak
2 pp	5132.10	-46.09	-44.35	-13.00	-33.09	-1.74	Peak

Bureau Veritas Consumer Products Services Ltd., Taoyuan



A D T

Data: 2

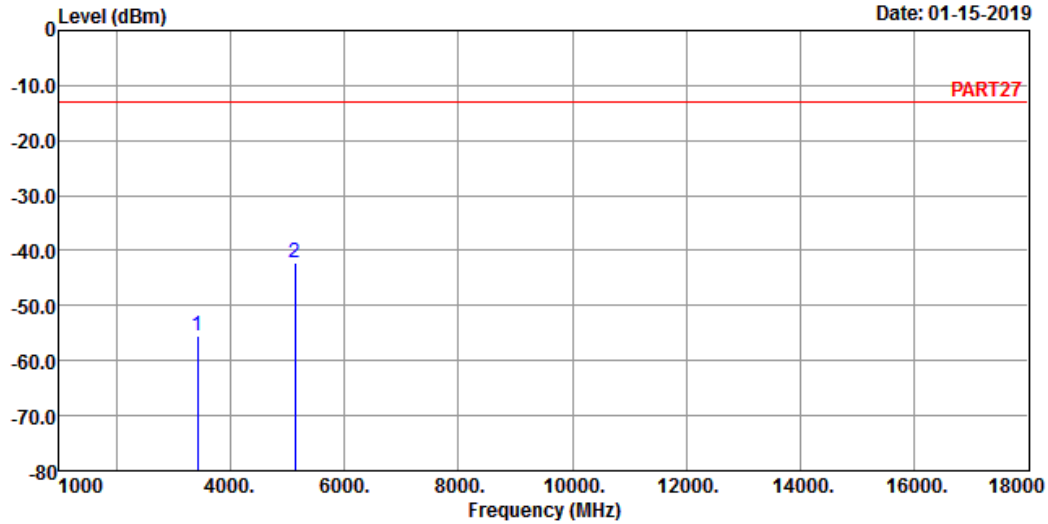

Site : 966 Chamber 5
 Condition: PART27 VERTICAL
 Remak : Cat-M1 Band 4 QPSK_1.4M Link_L-CH
 Tested by: Thomas Wei

	Freq	Level	Read Level	Limit Line	Over Limit	Factor	Remark
	MHz	dBm	dBm	dBm	dB	dB	
1	3421.40	-55.41	-47.07	-13.00	-42.41	-8.34	Peak
2	5132.10	-42.13	-40.39	-13.00	-29.13	-1.74	Peak

Middle Channel

Bureau Veritas Consumer Products Services Ltd., Taoyuan



A D T

Data: 1

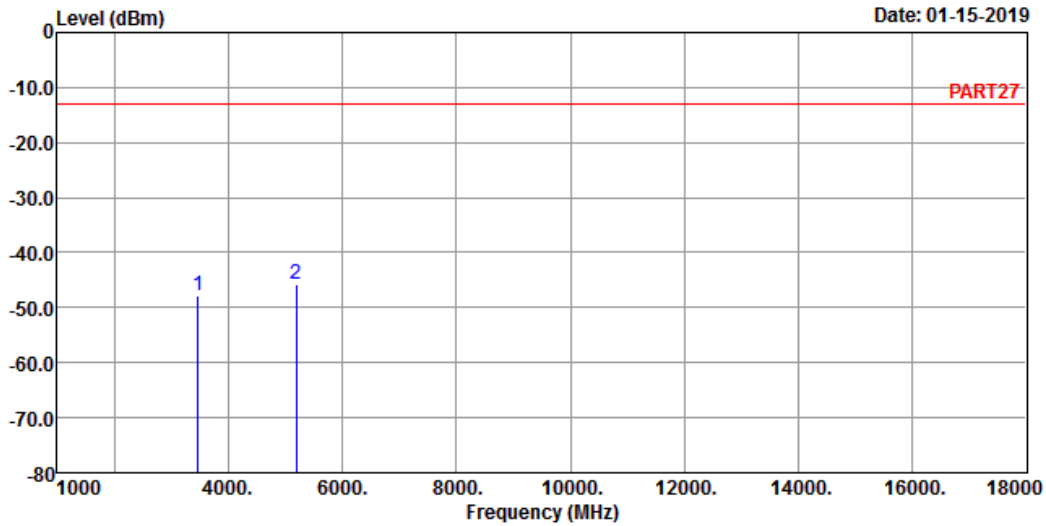

Site : 966 Chamber 5
 Condition: PART27 HORIZONTAL
 Remak : Cat-M1 Band 4 QPSK_1.4M Link_M-CH
 Tested by: Thomas Wei

	Read	Limit	Over			
Freq	Level	Level	Line	Limit	Factor	Remark
MHz	dBm	dBm	dBm	dB	dB	
1	3465.00	-47.89	-40.01	-13.00	-34.89	-7.88 Peak
2 pp	5197.50	-45.66	-43.59	-13.00	-32.66	-2.07 Peak

Bureau Veritas Consumer Products Services Ltd., Taoyuan



A D T

Data: 2

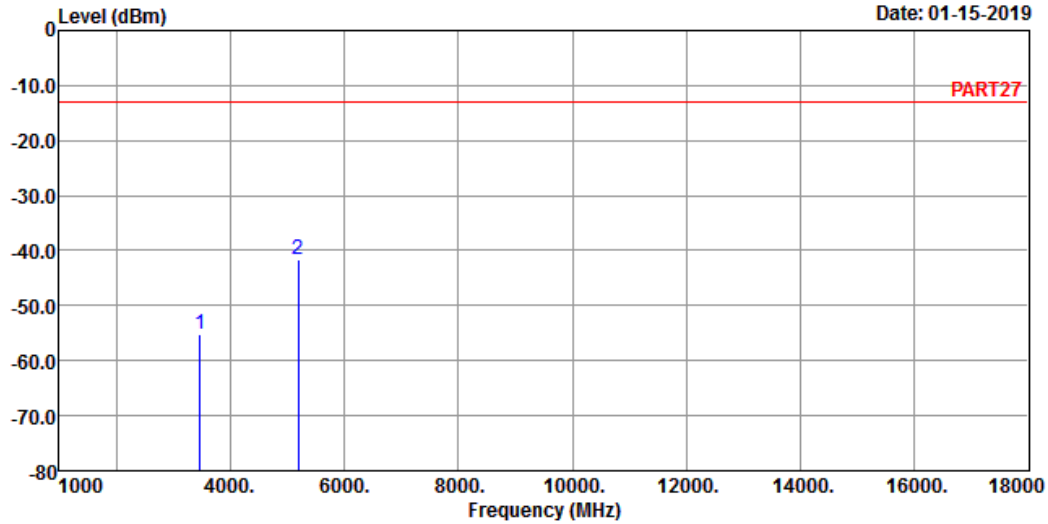

Site : 966 Chamber 5
 Condition: PART27 VERTICAL
 Remak : Cat-M1 Band 4 QPSK_1.4M Link_M-CH
 Tested by: Thomas Wei

	Freq	Level	Read Level	Limit Line	Over Limit	Factor	Remark
	MHz	dBm	dBm	dBm	dB	dB	
1	3465.00	-55.20	-47.32	-13.00	-42.20	-7.88	Peak
2 pp	5197.50	-41.63	-39.56	-13.00	-28.63	-2.07	Peak

High Channel

Bureau Veritas Consumer Products Services Ltd., Taoyuan



A D T

Data: 1

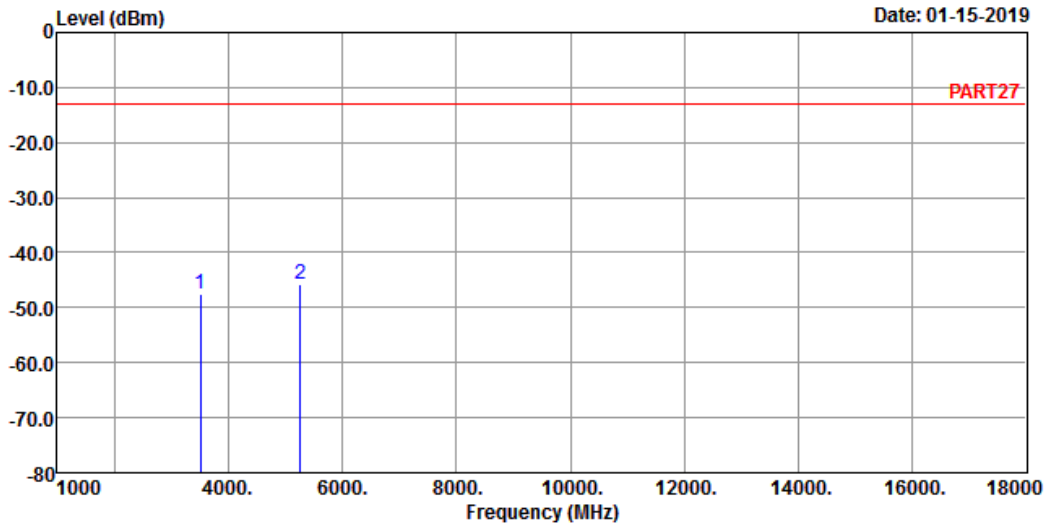

Site : 966 Chamber 5
 Condition: PART27 HORIZONTAL
 Remak : Cat-M1 Band 4 QPSK_1.4M Link_H-CH
 Tested by: Thomas Wei

	Read	Limit	Over				
Freq	Level	Level	Line	Limit	Factor	Remark	
MHz	dBm	dBm	dBm	dB	dB		
1	3508.60	-47.49	-40.04	-13.00	-34.49	-7.45	Peak
2 pp	5262.90	-45.81	-43.29	-13.00	-32.81	-2.52	Peak

Bureau Veritas Consumer Products Services Ltd., Taoyuan



A D T

Data: 2

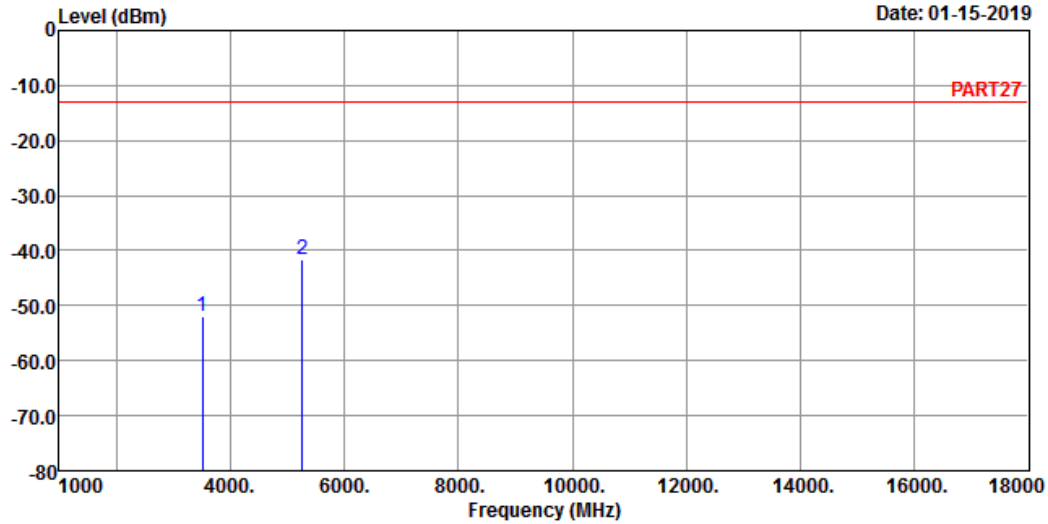

Site : 966 Chamber 5
 Condition: PART27 VERTICAL
 Remak : Cat-M1 Band 4 QPSK_1.4M Link_H-CH
 Tested by: Thomas Wei

	Freq	Level	Read Level	Limit Line	Over Limit	Factor	Remark
	MHz	dBm	dBm	dBm	dB	dB	
1	3508.60	-51.98	-44.53	-13.00	-38.98	-7.45	Peak
2 pp	5262.90	-41.67	-39.15	-13.00	-28.67	-2.52	Peak

Channel Bandwidth: 5 MHz / QPSK
Low Channel

Bureau Veritas Consumer Products Services Ltd., Taoyuan



A D T

Data: 1

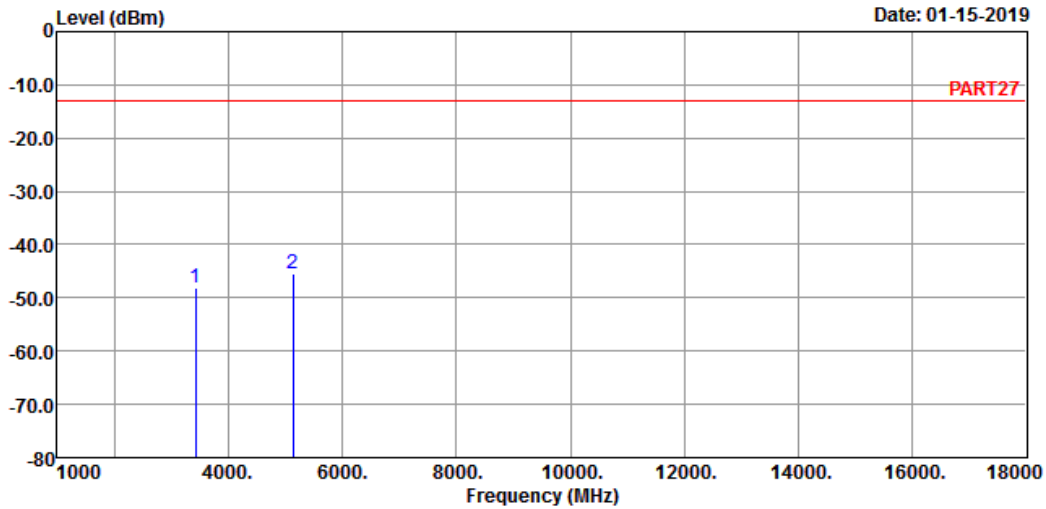

Site : 966 Chamber 5
Condition: PART27 HORIZONTAL
Remak : Cat-M1 Band 4 QPSK_5M Link_L-CH
Tested by: Thomas Wei

	Freq	Level	Read Level	Limit Line	Over Limit	Factor	Remark
	MHz	dBm	dBm	dBm	dB	dB	
1	3425.00	-48.13	-39.79	-13.00	-35.13	-8.34	Peak
2 pp	5137.50	-45.60	-43.86	-13.00	-32.60	-1.74	Peak

Bureau Veritas Consumer Products Services Ltd., Taoyuan



A D T

Data: 2

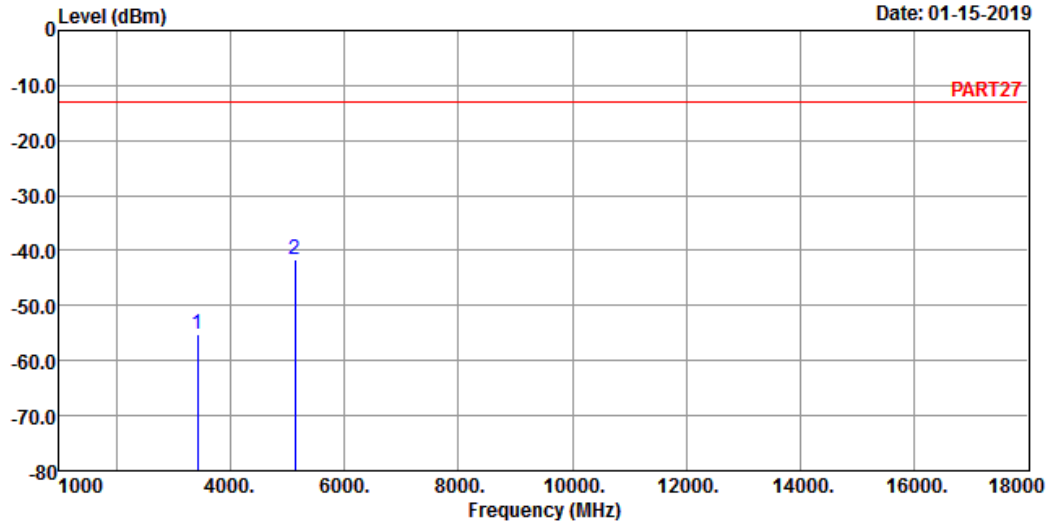

Site : 966 Chamber 5
 Condition: PART27 VERTICAL
 Remak : Cat-M1 Band 4 QPSK_5M Link_L-CH
 Tested by: Thomas Wei

	Freq	Level	Read Level	Limit Line	Over Limit	Factor	Remark
	MHz	dBm	dBm	dBm	dB	dB	
1	3425.00	-55.33	-46.99	-13.00	-42.33	-8.34	Peak
2	5137.50	-41.76	-40.02	-13.00	-28.76	-1.74	Peak

Middle Channel

Bureau Veritas Consumer Products Services Ltd., Taoyuan



A D T

Data: 1

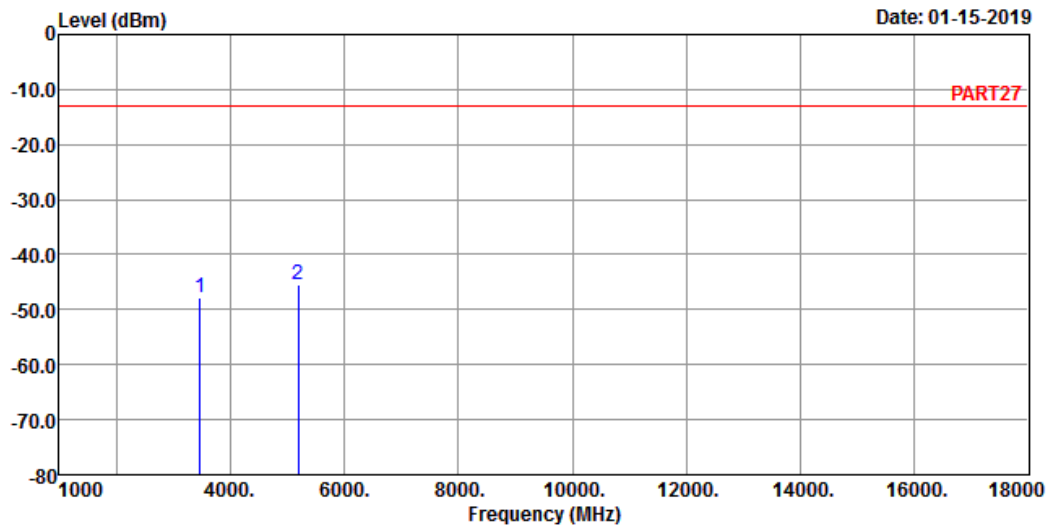

Site : 966 Chamber 5
 Condition: PART27 HORIZONTAL
 Remak : Cat-M1 Band 4 QPSK_5M Link_M-CH
 Tested by: Thomas Wei

	Freq	Level	Read Level	Limit Line	Over Limit	Factor	Remark
	MHz	dBm	dBm	dBm	dB	dB	
1	3465.00	-47.70	-39.82	-13.00	-34.70	-7.88	Peak
2 pp	5197.50	-45.33	-43.26	-13.00	-32.33	-2.07	Peak

Bureau Veritas Consumer Products Services Ltd., Taoyuan



A D T

Data: 2

Date: 01-15-2019

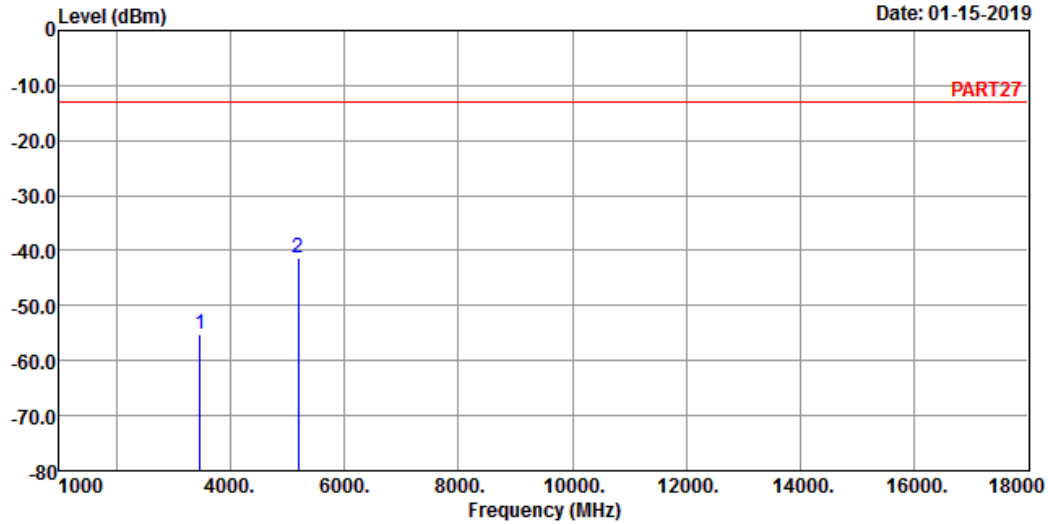

Site : 966 Chamber 5
 Condition: PART27 VERTICAL
 Remak : Cat-M1 Band 4 QPSK_5M Link_M-CH
 Tested by: Thomas Wei

	Freq	Level	Read Level	Limit Line	Over Limit	Factor	Remark
	MHz	dBm	dBm	dBm	dB	dB	
1	3465.00	-55.11	-47.23	-13.00	-42.11	-7.88	Peak
2 pp	5197.50	-41.46	-39.39	-13.00	-28.46	-2.07	Peak

High Channel

Bureau Veritas Consumer Products Services Ltd., Taoyuan



A D T

Data: 1

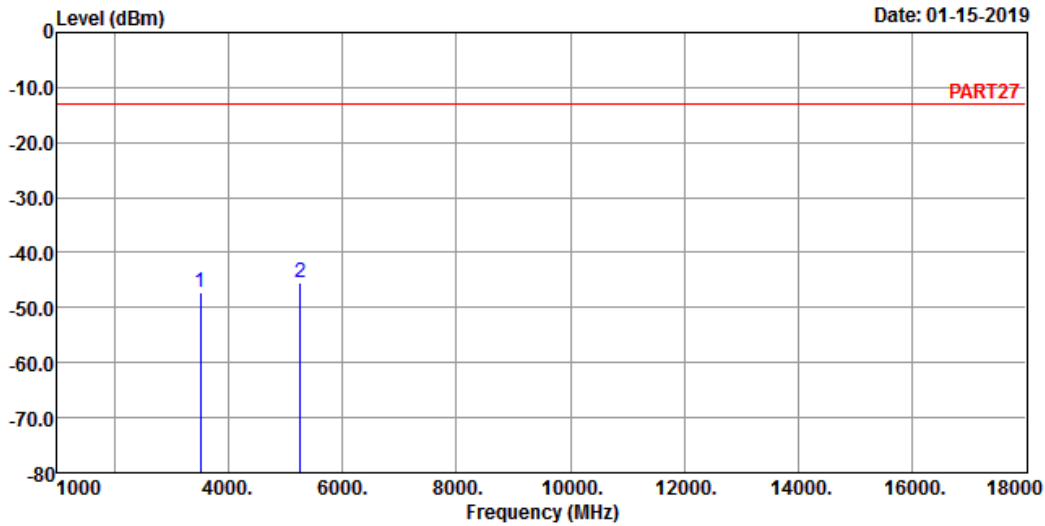

Site : 966 Chamber 5
 Condition: PART27 HORIZONTAL
 Remak : Cat-M1 Band 4 QPSK_5M Link_H-CH
 Tested by: Thomas Wei

	Freq	Level	Read Level	Limit Line	Over Limit	Factor	Remark
	MHz	dBm	dBm	dBm	dB	dB	
1	3505.00	-47.28	-39.83	-13.00	-34.28	-7.45	Peak
2 pp	5257.50	-45.46	-42.94	-13.00	-32.46	-2.52	Peak

Bureau Veritas Consumer Products Services Ltd., Taoyuan



A D T

Data: 2

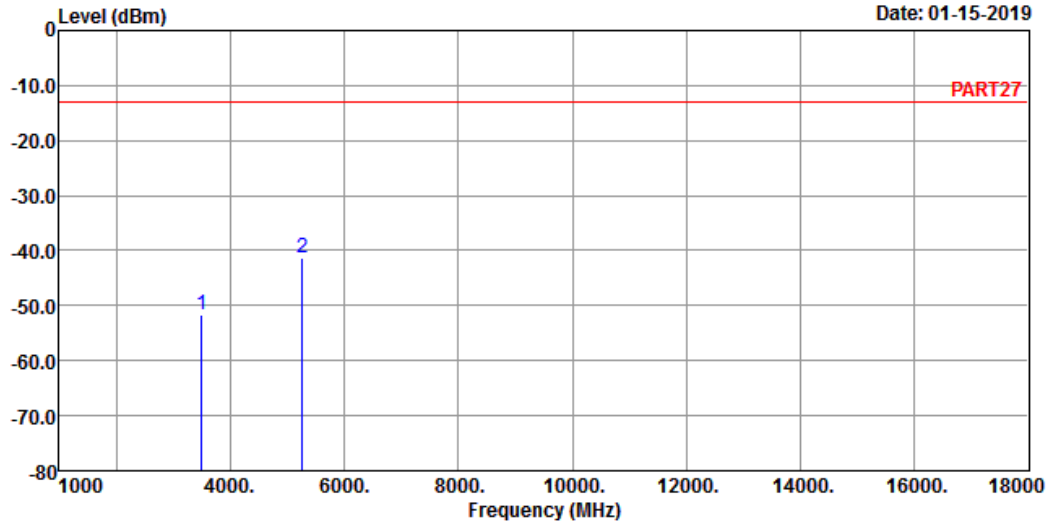

Site : 966 Chamber 5
 Condition: PART27 VERTICAL
 Remak : Cat-M1 Band 4 QPSK_5M Link_H-CH
 Tested by: Thomas Wei

	Freq	Level	Read Level	Limit Line	Over Limit	Factor	Remark
	MHz	dBm	dBm	dBm	dB	dB	
1	3490.00	-51.69	-44.04	-13.00	-38.69	-7.65	Peak
2 pp	5257.50	-41.21	-38.69	-13.00	-28.21	-2.52	Peak

Channel Bandwidth: 20 MHz / QPSK
Low Channel

Bureau Veritas Consumer Products Services Ltd., Taoyuan



A D T

Data: 1

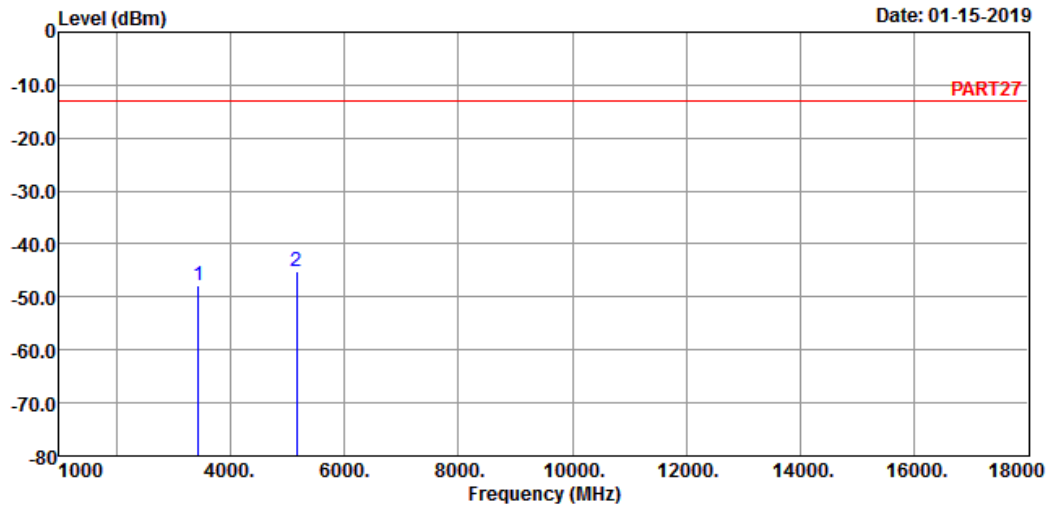

Site : 966 Chamber 5
Condition: PART27 HORIZONTAL
Remak : Cat-M1 Band 4 QPSK_20M Link_L-CH
Tested by: Thomas Wei

	Freq	Level	Read Level	Limit Line	Over Limit	Factor	Remark
	MHz	dBm	dBm	dBm	dB	dB	
1	3440.00	-47.85	-39.63	-13.00	-34.85	-8.22	Peak
2 pp	5160.00	-45.29	-43.38	-13.00	-32.29	-1.91	Peak

Bureau Veritas Consumer Products Services Ltd., Taoyuan



A D T

Data: 2

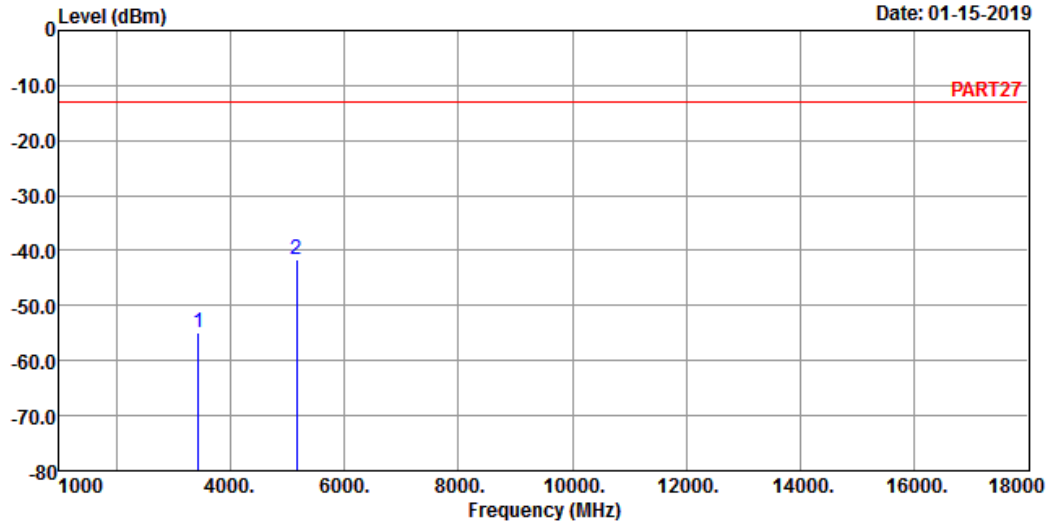

Site : 966 Chamber 5
 Condition: PART27 VERTICAL
 Remak : Cat-M1 Band 4 QPSK_20M Link_L-CH
 Tested by: Thomas Wei

	Freq	Level	Read Level	Limit Line	Over Limit	Factor	Remark
	MHz	dBm	dBm	dBm	dB	dB	
1	3440.00	-54.91	-46.69	-13.00	-41.91	-8.22	Peak
2 pp	5160.00	-41.49	-39.58	-13.00	-28.49	-1.91	Peak

Middle Channel

Bureau Veritas Consumer Products Services Ltd., Taoyuan



A D T

Data: 1

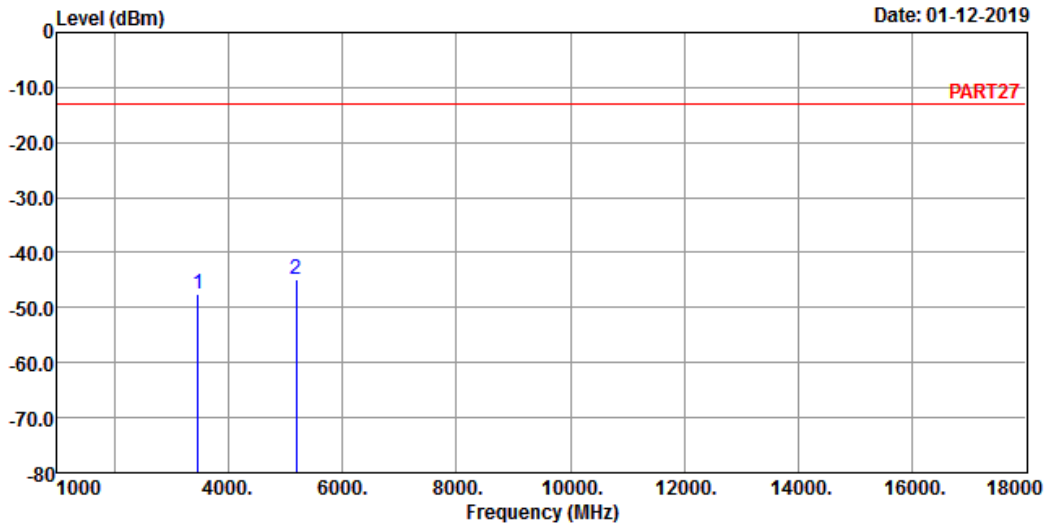

Site : 966 Chamber 5
 Condition: PART27 HORIZONTAL
 Remak : Cat-M1 Band 4 QPSK_20M Link_M-CH
 Tested by: Thomas Wei

	Freq	Level	Read Level	Limit Line	Over Limit	Factor	Remark
	MHz	dBm	dBm	dBm	dB	dB	
1	3465.00	-47.43	-39.55	-13.00	-34.43	-7.88	Peak
2 pp	5197.50	-44.94	-42.87	-13.00	-31.94	-2.07	Peak

Bureau Veritas Consumer Products Services Ltd., Taoyuan



A D T

Data: 2

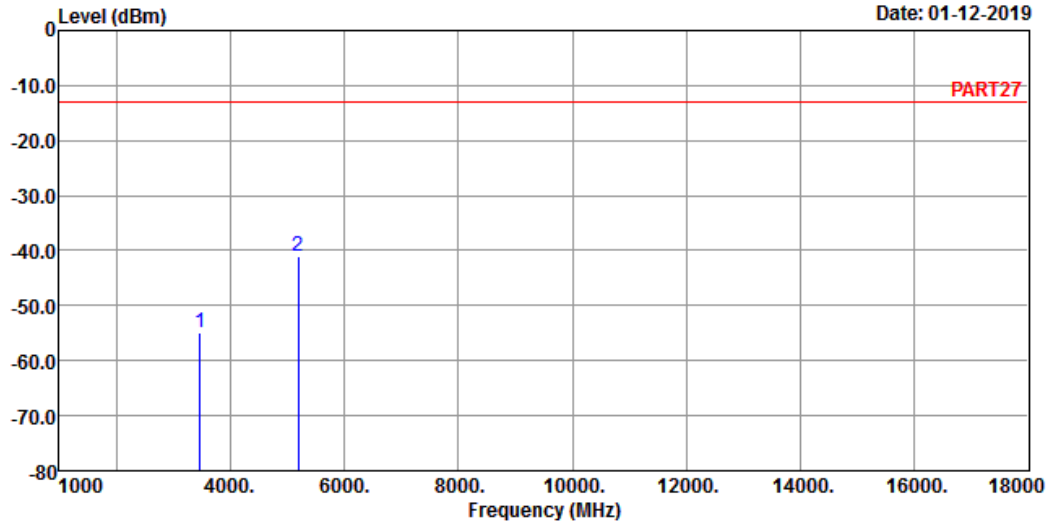

Site : 966 Chamber 5
 Condition: PART27 VERTICAL
 Remak : Cat-M1 Band 4 QPSK_20M Link_M-CH
 Tested by: Thomas Wei

	Freq	Level	Read Level	Limit Line	Over Limit	Factor	Remark
	MHz	dBm	dBm	dBm	dB	dB	
1	3465.00	-54.91	-47.03	-13.00	-41.91	-7.88	Peak
2 pp	5197.50	-41.08	-39.01	-13.00	-28.08	-2.07	Peak

High Channel

Bureau Veritas Consumer Products Services Ltd., Taoyuan



A D T

Data: 5

Date: 01-12-2019

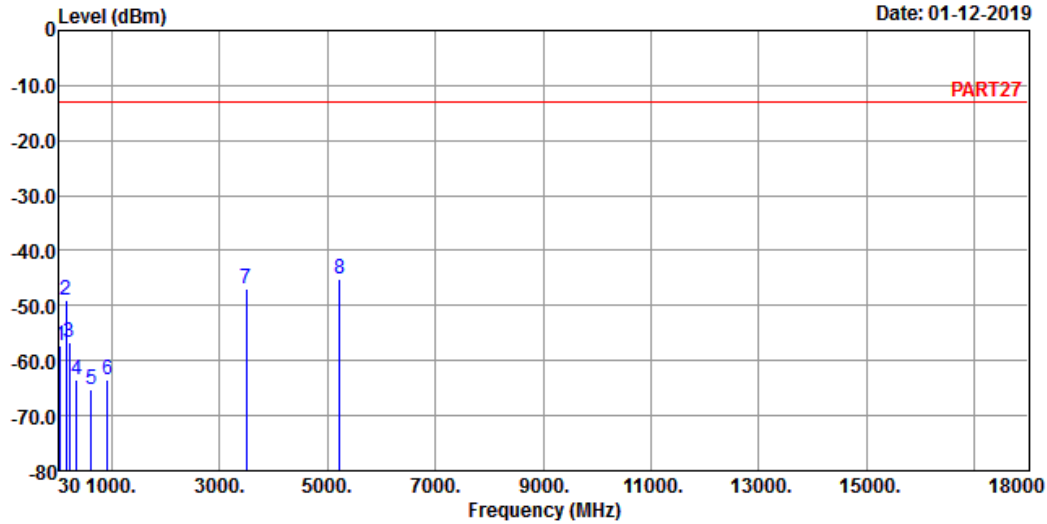

Site : 966 Chamber 5
 Condition: PART27 HORIZONTAL
 Remak : Cat-M1 Band 4 QPSK_20M Link_H-CH
 Tested by: Thomas Wei

	Freq	Level	Read Level	Limit	Over	Factor	Remark
	MHz	dBm	dBm	dBm	dB	dB	
1	43.58	-57.31	-55.84	-13.00	-44.31	-1.47	Peak
2	152.22	-49.09	-42.06	-13.00	-36.09	-7.03	Peak
3	215.27	-56.79	-49.39	-13.00	-43.79	-7.40	Peak
4	346.22	-63.60	-57.30	-13.00	-50.60	-6.30	Peak
5	620.73	-65.13	-64.32	-13.00	-52.13	-0.81	Peak
6	930.16	-63.57	-64.89	-13.00	-50.57	1.32	Peak
7	3490.00	-47.07	-39.42	-13.00	-34.07	-7.65	Peak
8 pp	5235.00	-45.21	-42.80	-13.00	-32.21	-2.41	Peak

Bureau Veritas Consumer Products Services Ltd., Taoyuan



A D T

Data: 6

Date: 01-12-2019

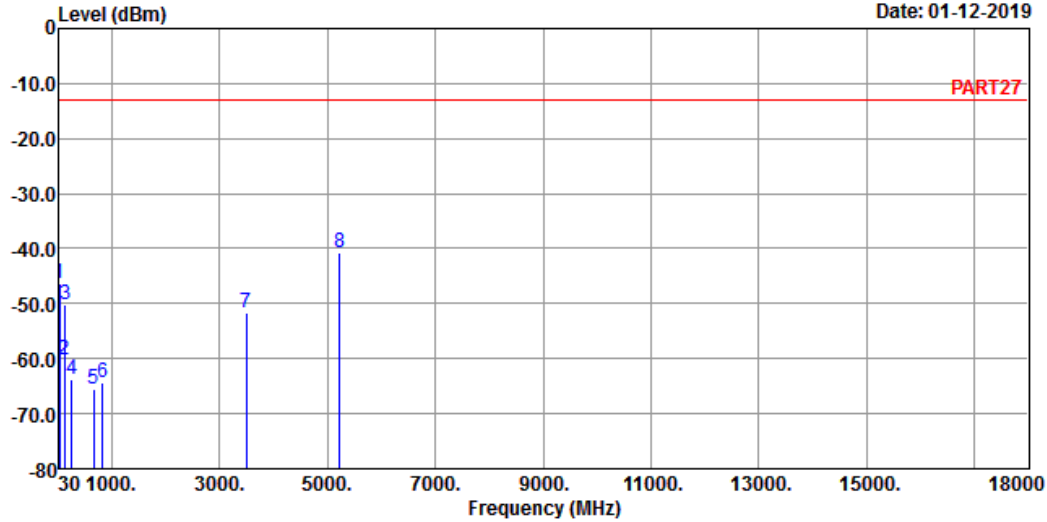

Site : 966 Chamber 5
 Condition: PART27 VERTICAL
 Remak : Cat-M1 Band 4 QPSK_20M Link_H-CH
 Tested by: Thomas Wei

	Freq	Level	Read Level	Limit Line	Over Limit	Factor	Remark
	MHz	dBm	dBm	dBm	dB	dB	
1	30.00	-46.29	-46.67	-13.00	-33.29	0.38	Peak
2	124.09	-60.31	-50.92	-13.00	-47.31	-9.39	Peak
3	145.43	-50.15	-42.08	-13.00	-37.15	-8.07	Peak
4	253.10	-63.72	-57.67	-13.00	-50.72	-6.05	Peak
5	668.26	-65.51	-64.91	-13.00	-52.51	-0.60	Peak
6	837.04	-64.48	-64.88	-13.00	-51.48	0.40	Peak
7	3490.00	-51.69	-44.04	-13.00	-38.69	-7.65	Peak
8 pp	5235.00	-40.74	-38.33	-13.00	-27.74	-2.41	Peak

LTE Band 12
 Channel Bandwidth: 1.4 MHz / QPSK
 Low Channel

Bureau Veritas Consumer Products Services Ltd., Taoyuan



A D T

Data: 1

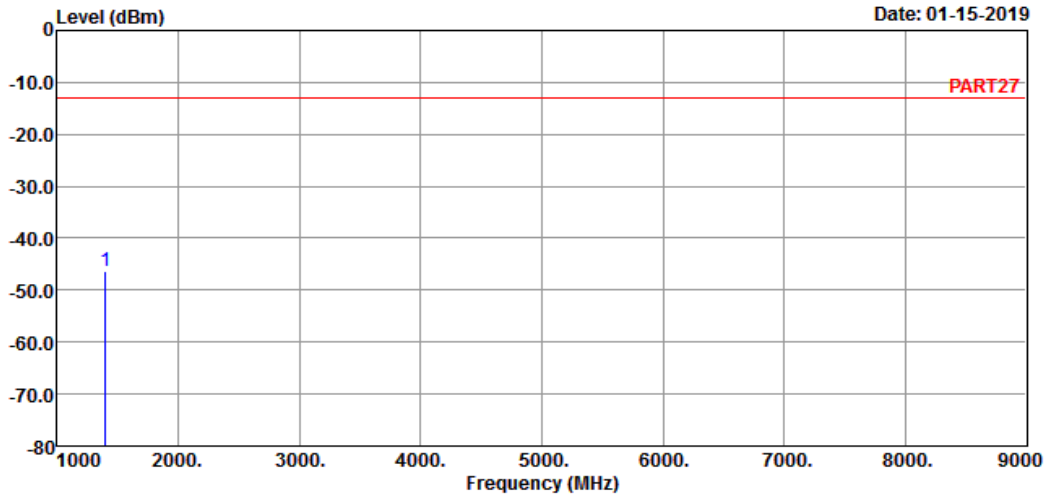

Site : 966 Chamber 5
 Condition: PART27 HORIZONTAL
 Remak : Cat-M1 Band 12 QPSK_1.4M Link_L-CH
 Tested by: Thomas Wei

	Read	Limit	Over			
Freq	Level	Level	Line	Limit	Factor	Remark
MHz	dBm	dBm	dBm	dB	dB	
1 pp 1399.40	-46.25	-34.40	-13.00	-33.25	-11.85	Peak

Bureau Veritas Consumer Products Services Ltd., Taoyuan



A D T

Data: 2

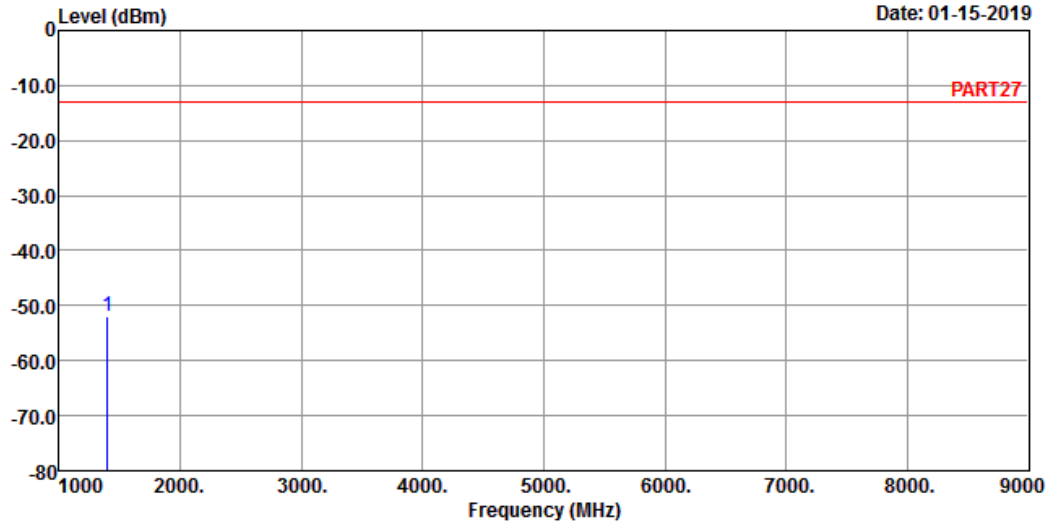

Site : 966 Chamber 5
 Condition: PART27 VERTICAL
 Remak : Cat-M1 Band 12 QPSK_1.4M Link_L-CH
 Tested by: Thomas Wei

Freq	Level	Read Level	Limit Line	Over Limit	Factor	Remark
MHz	dBm	dBm	dBm	dB	dB	
1 pp 1399.40	-51.97	-40.12	-13.00	-38.97	-11.85	Peak

Middle Channel

Bureau Veritas Consumer Products Services Ltd., Taoyuan



A D T

Data: 1

Date: 01-15-2019

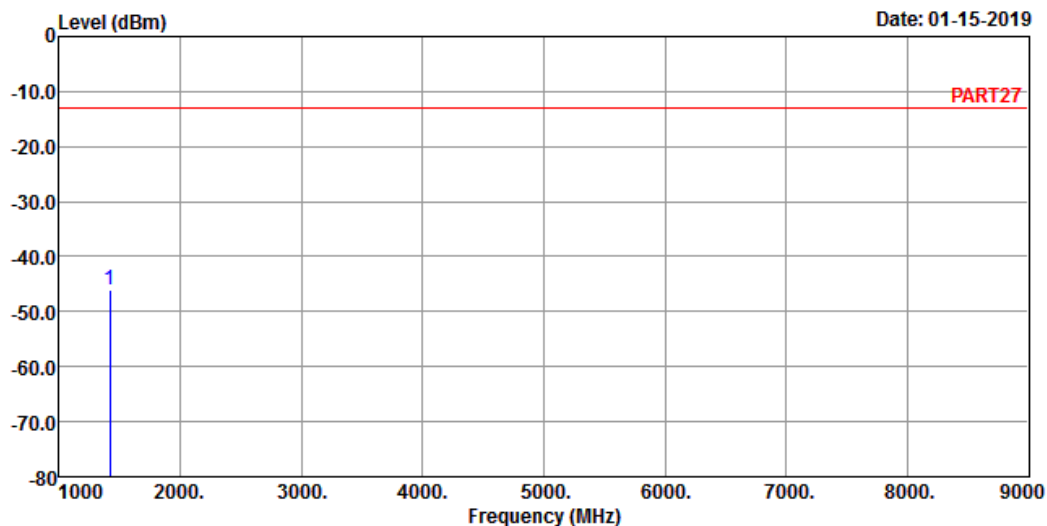

Site : 966 Chamber 5
 Condition: PART27 HORIZONTAL
 Remak : Cat-M1 Band 12 QPSK_1.4M Link_M-CH
 Tested by: Thomas Wei

Freq	Level	Read Level	Limit Line	Over Limit	Factor	Remark
MHz	dBm	dBm	dBm	dB	dB	

1 pp 1415.00 -46.18 -34.10 -13.00 -33.18 -12.08 Peak

Bureau Veritas Consumer Products Services Ltd., Taoyuan



A D T

Data: 2

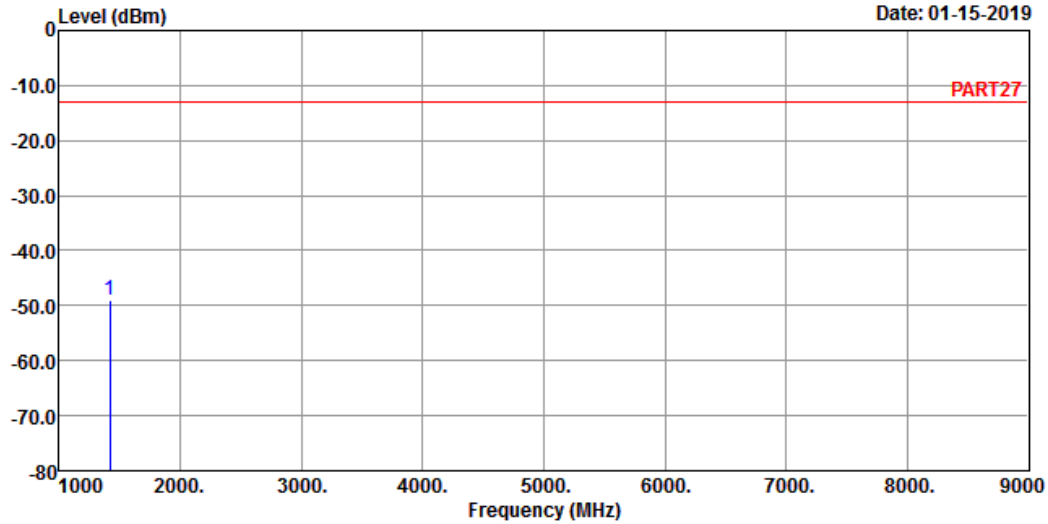

Site : 966 Chamber 5
 Condition: PART27 VERTICAL
 Remak : Cat-M1 Band 12 QPSK_1.4M Link_M-CH
 Tested by: Thomas Wei

Freq	Level	Read Level	Limit Line	Over Limit	Factor	Remark
MHz	dBm	dBm	dBm	dB	dB	
1415.00	-49.09	-37.01	-13.00	-36.09	-12.08	Peak

High Channel

Bureau Veritas Consumer Products Services Ltd., Taoyuan



A D T

Data: 1

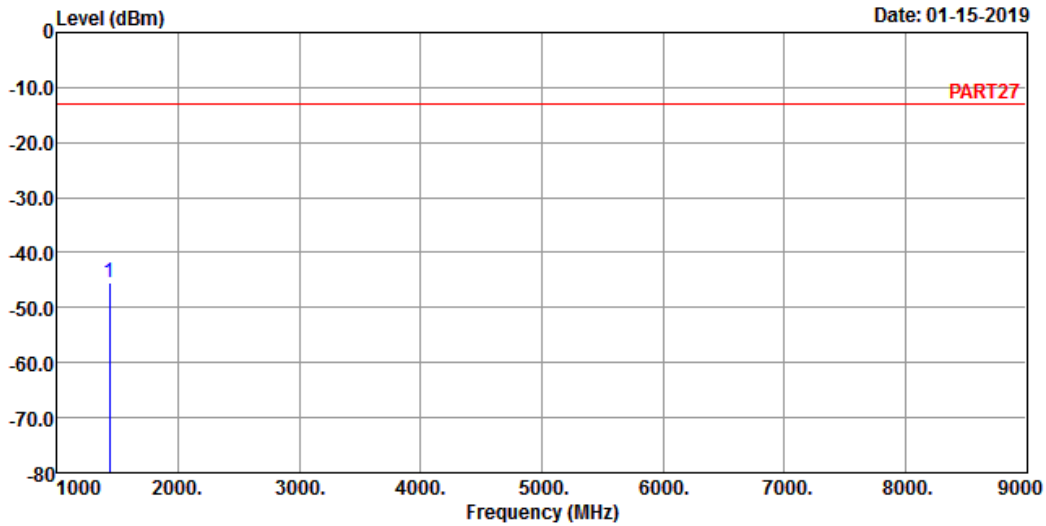

Site : 966 Chamber 5
 Condition: PART27 HORIZONTAL
 Remak : Cat-M1 Band 12 QPSK_1.4M Link_H-CH
 Tested by: Thomas Wei

Freq	Level	Read Level	Limit Line	Over Limit	Factor	Remark
MHz	dBm	dBm	dBm	dB	dB	

1 pp 1430.60 -45.47 -33.16 -13.00 -32.47 -12.31 Peak

Bureau Veritas Consumer Products Services Ltd., Taoyuan



A D T

Data: 2

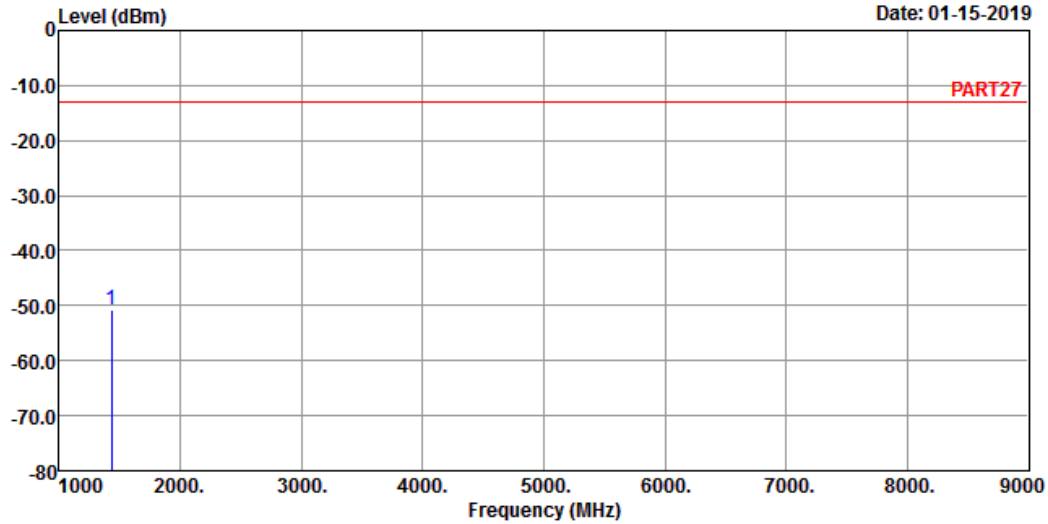

Site : 966 Chamber 5
 Condition: PART27 VERTICAL
 Remak : Cat-M1 Band 12 QPSK_1.4M Link_H-CH
 Tested by: Thomas Wei

Freq	Level	Read Level	Limit Line	Over Limit	Factor	Remark
MHz	dBm	dBm	dBm	dB	dB	

1 pp 1430.60 -50.78 -38.47 -13.00 -37.78 -12.31 Peak

Channel Bandwidth: 5 MHz / QPSK
Low Channel

Bureau Veritas Consumer Products Services Ltd., Taoyuan



A D T

Data: 1

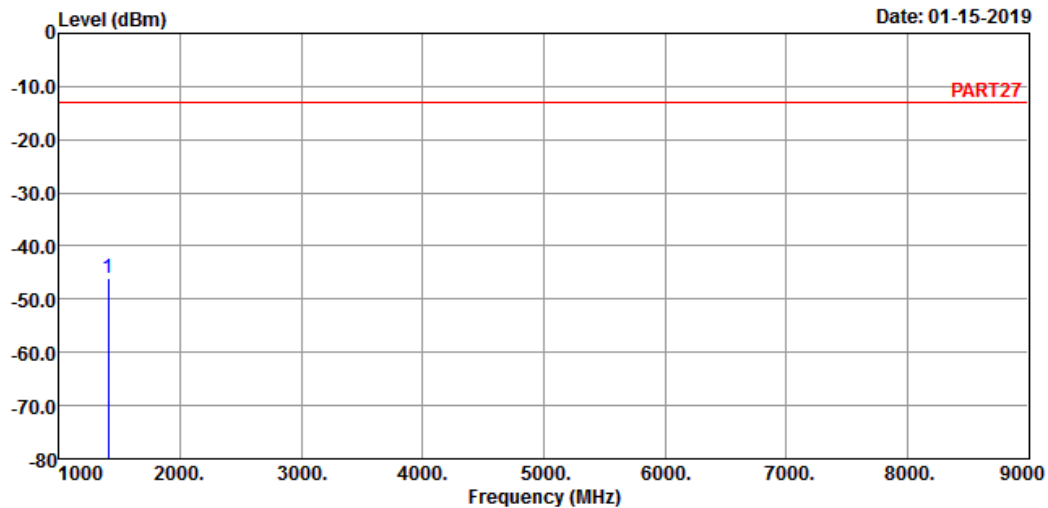

Site : 966 Chamber 5
Condition: PART27 HORIZONTAL
Remak : Cat-M1 Band 12 QPSK_5M Link_L-CH
Tested by: Thomas Wei

Freq	Level	Read Level	Limit Line	Over Limit	Factor	Remark
MHz	dBm	dBm	dBm	dB	dB	

1 pp 1403.00 -45.91 -34.00 -13.00 -32.91 -11.91 Peak

Bureau Veritas Consumer Products Services Ltd., Taoyuan



A D T

Data: 2

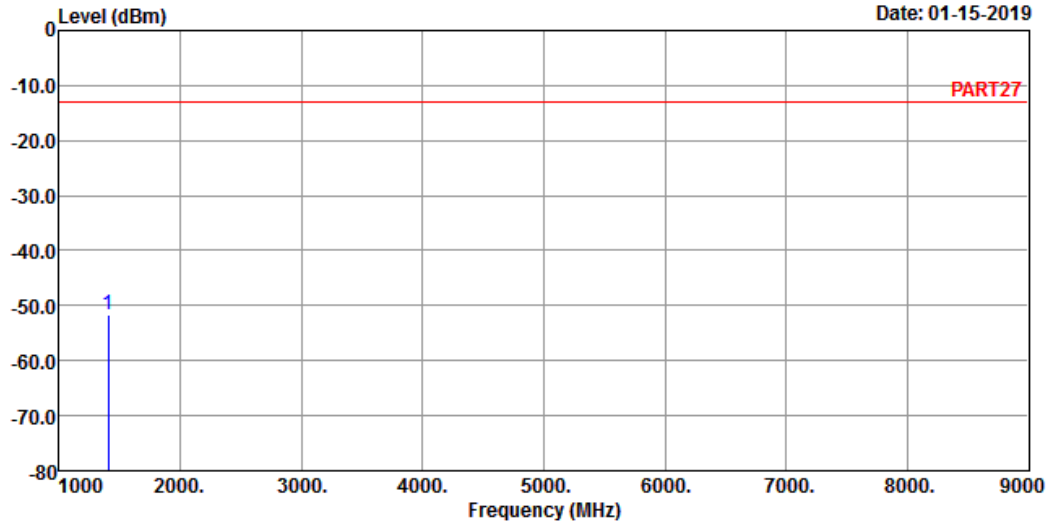

Site : 966 Chamber 5
 Condition: PART27 VERTICAL
 Remak : Cat-M1 Band 12 QPSK_5M Link_L-CH
 Tested by: Thomas Wei

Freq	Level	Read Level	Limit Line	Over Limit	Factor	Remark
MHz	dBm	dBm	dBm	dB	dB	
1403.00	-51.79	-39.88	-13.00	-38.79	-11.91	Peak

Middle Channel

Bureau Veritas Consumer Products Services Ltd., Taoyuan



A D T

Data: 1

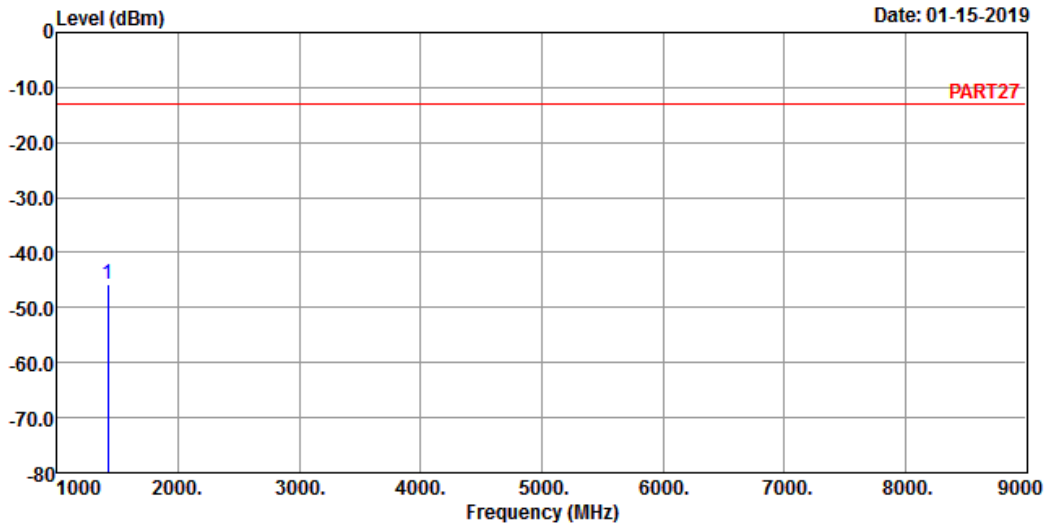

Site : 966 Chamber 5
 Condition: PART27 HORIZONTAL
 Remak : Cat-M1 Band 12 QPSK_5M Link_M-CH
 Tested by: Thomas Wei

Freq	Level	Read Level	Limit Line	Over Limit	Factor	Remark
MHz	dBm	dBm	dBm	dB	dB	

1 pp 1415.00 -45.80 -33.72 -13.00 -32.80 -12.08 Peak

Bureau Veritas Consumer Products Services Ltd., Taoyuan



A D T

Data: 2

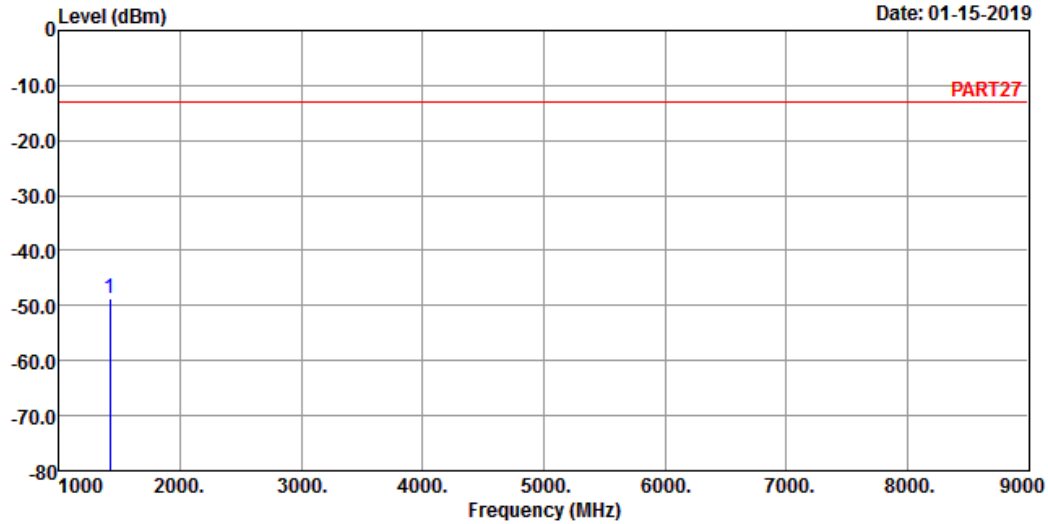

Site : 966 Chamber 5
 Condition: PART27 VERTICAL
 Remak : Cat-M1 Band 12 QPSK_5M Link_M-CH
 Tested by: Thomas Wei

Freq	Level	Read Level	Limit Line	Over Limit	Factor	Remark
MHz	dBm	dBm	dBm	dB	dB	
1 pp 1415.00	-48.72	-36.64	-13.00	-35.72	-12.08	Peak

High Channel

Bureau Veritas Consumer Products Services Ltd., Taoyuan



A D T

Data: 1

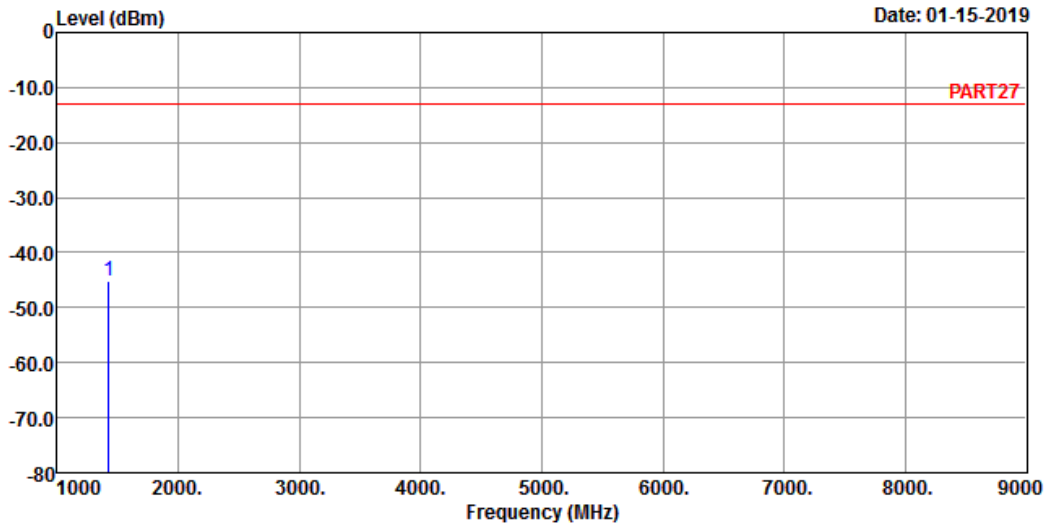

Site : 966 Chamber 5
 Condition: PART27 HORIZONTAL
 Remak : Cat-M1 Band 12 QPSK_5M Link_H-CH
 Tested by: Thomas Wei

Freq	Level	Read Level	Limit Line	Over Limit	Factor	Remark
MHz	dBm	dBm	dBm	dB	dB	

1 pp 1427.00 -45.03 -32.78 -13.00 -32.03 -12.25 Peak

Bureau Veritas Consumer Products Services Ltd., Taoyuan



A D T

Data: 2

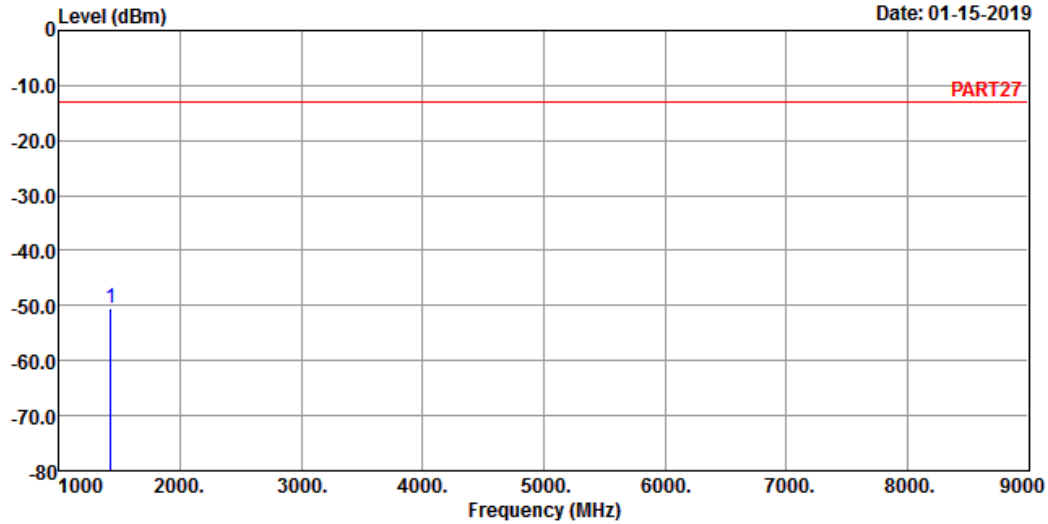

Site : 966 Chamber 5
 Condition: PART27 VERTICAL
 Remak : Cat-M1 Band 12 QPSK_5M Link_H-CH
 Tested by: Thomas Wei

Freq	Level	Read Level	Limit Line	Over Limit	Factor	Remark
MHz	dBm	dBm	dBm	dB	dB	
1 pp 1427.00	-50.42	-38.17	-13.00	-37.42	-12.25	Peak

Channel Bandwidth: 10 MHz / QPSK
Low Channel

Bureau Veritas Consumer Products Services Ltd., Taoyuan



A D T

Data: 1

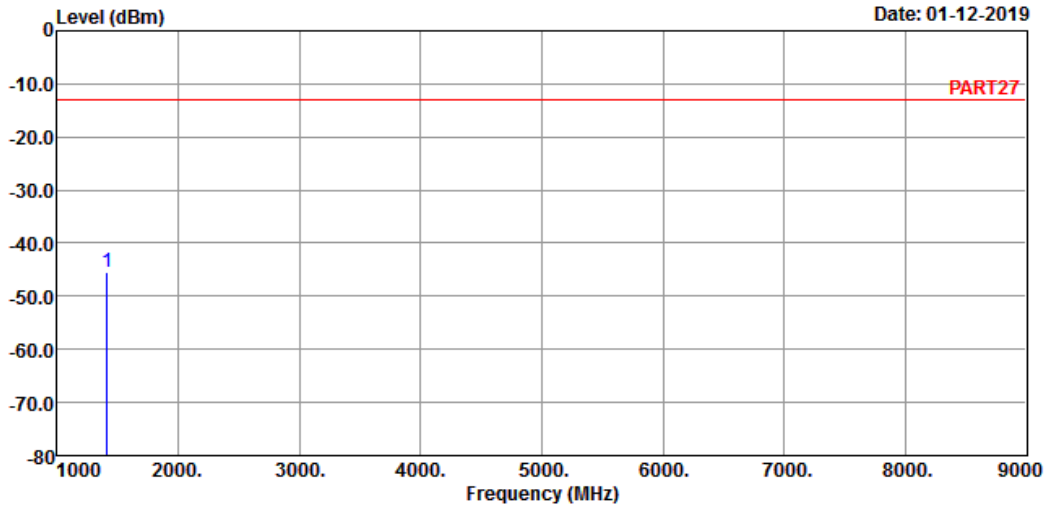

Site : 966 Chamber 5
Condition: PART27 HORIZONTAL
Remak : Cat-M1 Band 12 QPSK_10M Link_L-CH
Tested by: Thomas Wei

Freq	Level	Read Level	Limit Line	Over Limit	Factor	Remark
MHz	dBm	dBm	dBm	dB	dB	

1 pp 1408.00 -45.59 -33.63 -13.00 -32.59 -11.96 Peak

Bureau Veritas Consumer Products Services Ltd., Taoyuan



A D T

Data: 2

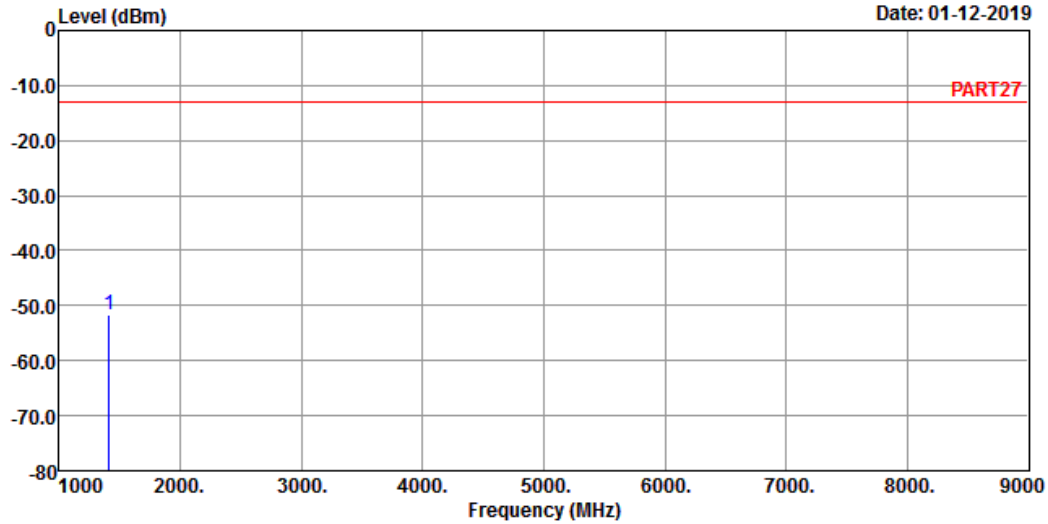

Site : 966 Chamber 5
 Condition: PART27 VERTICAL
 Remak : Cat-M1 Band 12 QPSK_10M Link_L-CH
 Tested by: Thomas Wei

Freq	Level	Read Level	Limit Line	Over Limit	Factor	Remark
MHz	dBm	dBm	dBm	dB	dB	
1408.00	-51.55	-39.59	-13.00	-38.55	-11.96	Peak

Middle Channel

Bureau Veritas Consumer Products Services Ltd., Taoyuan



A D T

Data: 1

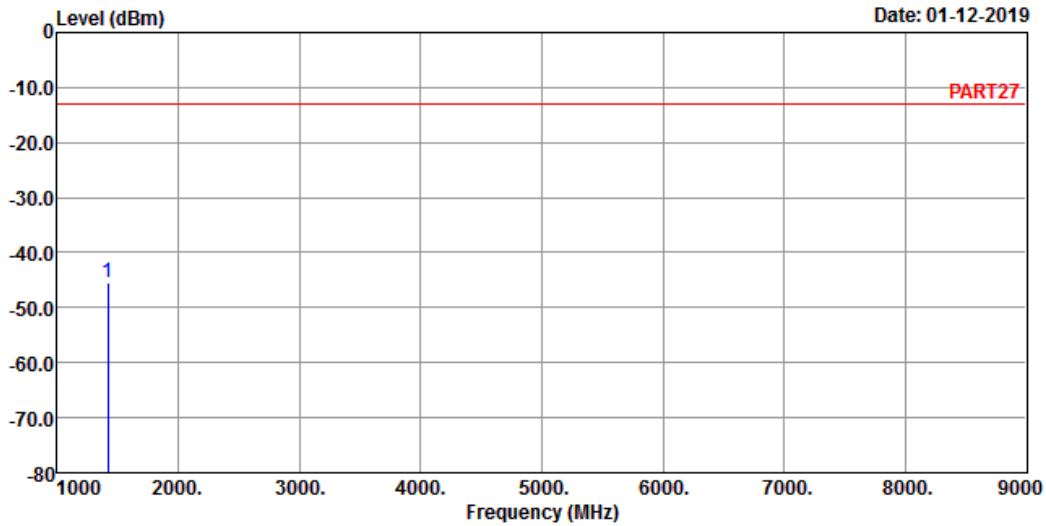

Site : 966 Chamber 5
 Condition: PART27 HORIZONTAL
 Remak : Cat-M1 Band 12 QPSK_10M Link_M-CH
 Tested by: Thomas Wei

Freq	Level	Read Level	Limit Line	Over Limit	Factor	Remark
MHz	dBm	dBm	dBm	dB	dB	

1 pp 1415.00 -45.36 -33.28 -13.00 -32.36 -12.08 Peak

Bureau Veritas Consumer Products Services Ltd., Taoyuan



A D T

Data: 2

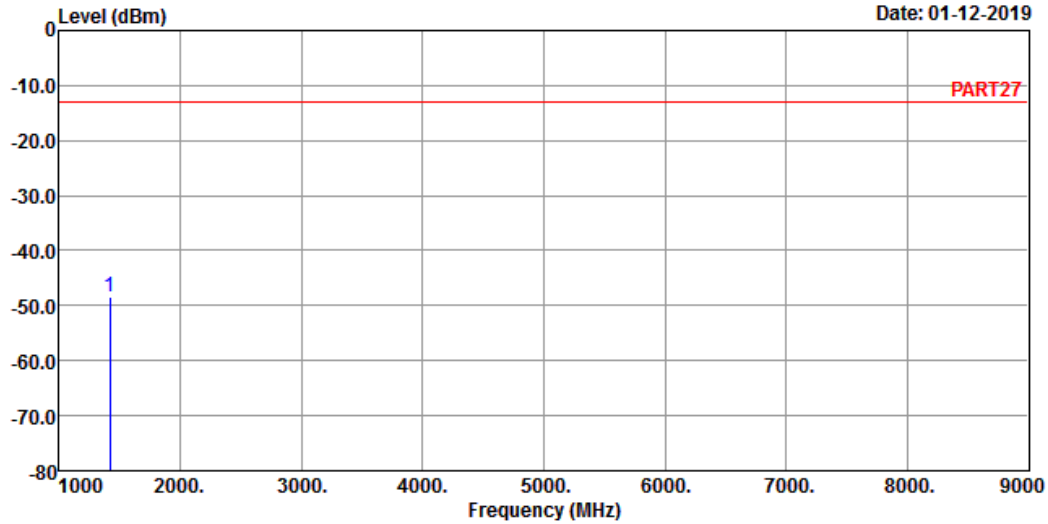

Site : 966 Chamber 5
 Condition: PART27 VERTICAL
 Remak : Cat-M1 Band 12 QPSK_10M Link_M-CH
 Tested by: Thomas Wei

Freq	Level	Read Level	Limit Line	Over Limit	Factor	Remark
MHz	dBm	dBm	dBm	dB	dB	
1 pp 1415.00	-48.36	-36.28	-13.00	-35.36	-12.08	Peak

High Channel

Bureau Veritas Consumer Products Services Ltd., Taoyuan



A D T

Data: 5

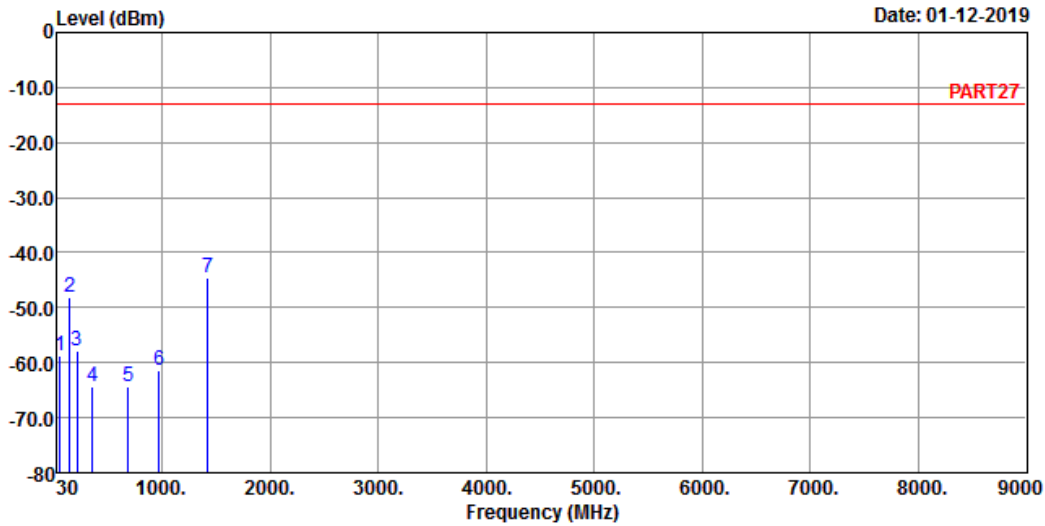

Site : 966 Chamber 5
 Condition: PART27 HORIZONTAL
 Remak : Cat-M1 Band 12 QPSK_10M Link_H-CH
 Tested by: Thomas Wei

	Read	Limit	Over				
Freq	Level	Level	Line	Limit	Factor	Remark	
MHz	dBm	dBm	dBm	dB	dB		
1	53.28	-58.74	-52.93	-13.00	-45.74	-5.81	Peak
2	147.37	-48.14	-40.27	-13.00	-35.14	-7.87	Peak
3	214.30	-57.85	-50.41	-13.00	-44.85	-7.44	Peak
4	353.01	-64.26	-58.04	-13.00	-51.26	-6.22	Peak
5	686.69	-64.34	-64.03	-13.00	-51.34	-0.31	Peak
6	971.87	-61.50	-64.09	-13.00	-48.50	2.59	Peak
7 pp	1422.00	-44.62	-32.43	-13.00	-31.62	-12.19	Peak

Bureau Veritas Consumer Products Services Ltd., Taoyuan



A D T

Data: 6

Date: 01-12-2019

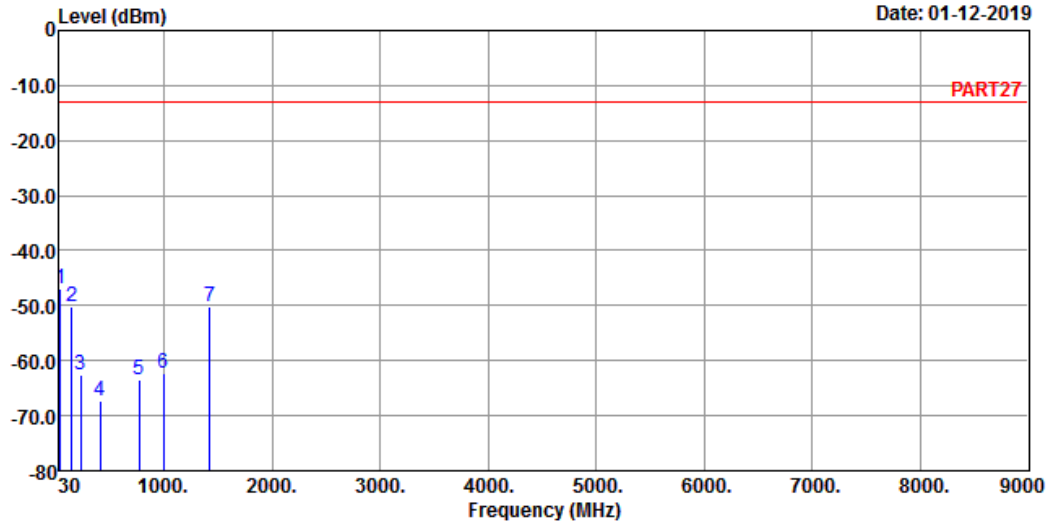

Site : 966 Chamber 5
 Condition: PART27 VERTICAL
 Remak : Cat-M1 Band 12 QPSK_10M Link_H-CH
 Tested by: Thomas Wei

	Freq	Level	Read Level	Limit Line	Over Limit	Factor	Remark
	MHz	dBm	dBm	dBm	dB	dB	
1 pp	41.64	-46.99	-46.58	-13.00	-33.99	-0.41	Peak
2	144.46	-50.13	-41.97	-13.00	-37.13	-8.16	Peak
3	228.85	-62.51	-55.66	-13.00	-49.51	-6.85	Peak
4	406.36	-67.45	-61.56	-13.00	-54.45	-5.89	Peak
5	771.08	-63.57	-64.39	-13.00	-50.57	0.82	Peak
6	995.15	-62.42	-65.83	-13.00	-49.42	3.41	Peak
7	1422.00	-50.08	-37.89	-13.00	-37.08	-12.19	Peak

LTE Band 13
Channel Bandwidth: 5 MHz / QPSK
Low Channel

Bureau Veritas Consumer Products Services Ltd., Taoyuan



A D T

Data: 1

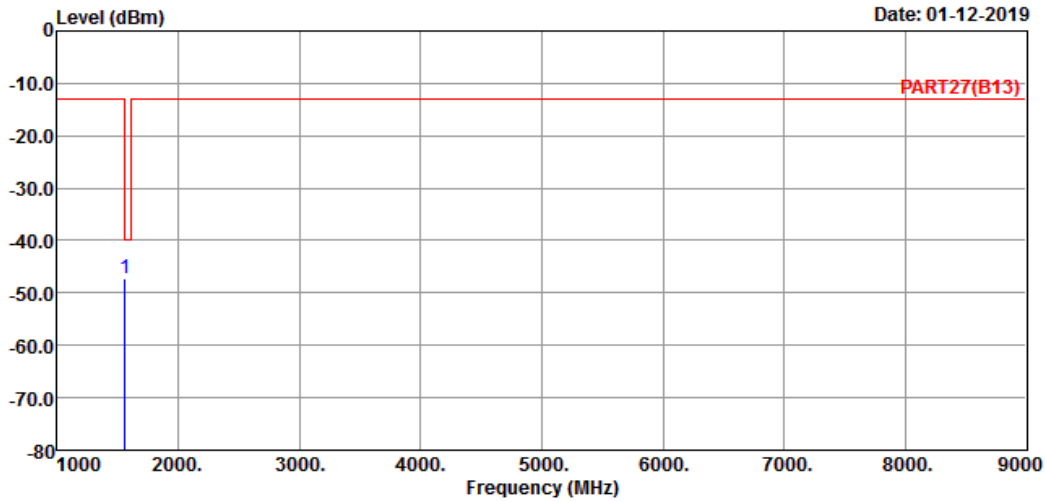

Site : 966 Chamber 5
Condition: PART27(B13) HORIZONTAL
Remak : Cat-M1 Band 13 QPSK_5M Link_L-CH
Tested by: Thomas Wei

	Read	Limit	Over			
Freq	Level	Level	Line	Limit	Factor	Remark
MHz	dBm	dBm	dBm	dB	dB	
1 pp 1559.00	-47.26	-33.94	-40.00	-7.26	-13.32	Peak



Data: 2

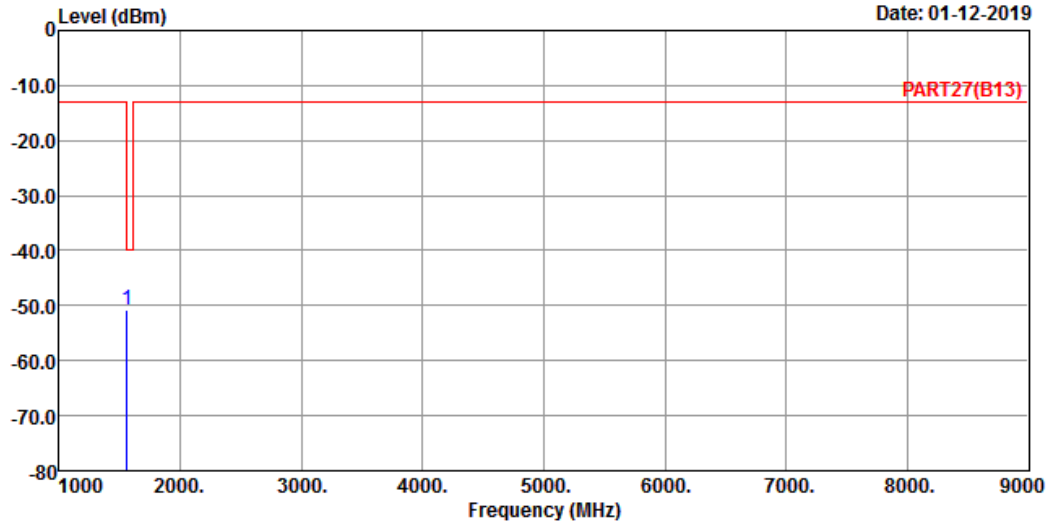

Site : 966 Chamber 5
 Condition: PART27(B13) VERTICAL
 Remak : Cat-M1 Band 13 QPSK_5M Link_L-CH
 Tested by: Thomas Wei

Freq	Level	Read Level	Limit Line	Over Limit	Factor	Remark
MHz	dBm	dBm	dBm	dB	dB	
1 pp 1559.00	-50.75	-37.43	-40.00	-10.75	-13.32	Peak

Middle Channel

Bureau Veritas Consumer Products Services Ltd., Taoyuan



A D T

Data: 1

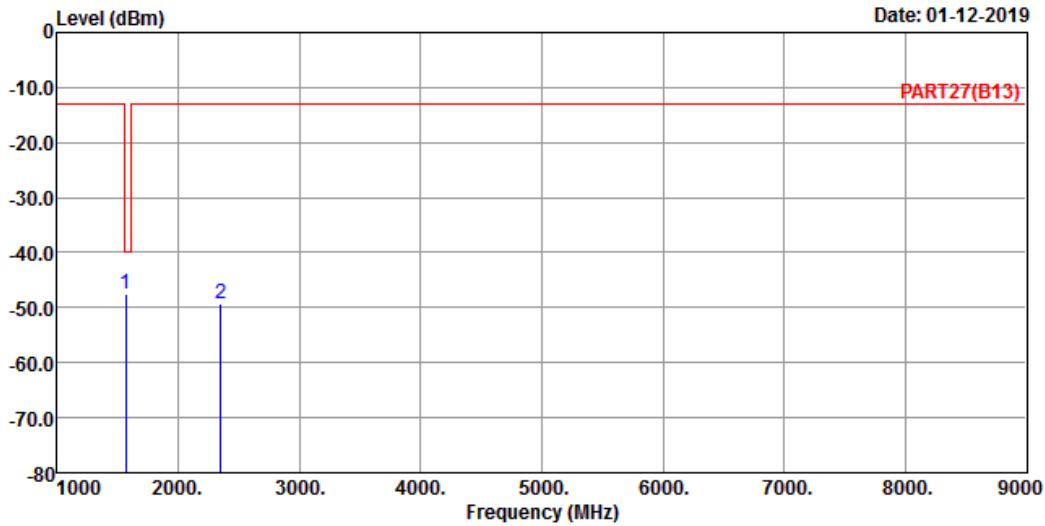

Site : 966 Chamber 5
 Condition: PART27(B13) HORIZONTAL
 Remak : Cat-M1 Band 13 QPSK_5M Link_M-CH
 Tested by: Thomas Wei

	Read	Limit	Over			
Freq	Level	Level	Line	Limit	Factor	Remark
MHz	dBm	dBm	dBm	dB	dB	
1 pp 1564.00	-47.38	-34.04	-40.00	-7.38	-13.34	Peak
2 2346.00	-49.32	-39.88	-13.00	-36.32	-9.44	Peak

Bureau Veritas Consumer Products Services Ltd., Taoyuan



A D T

Data: 2

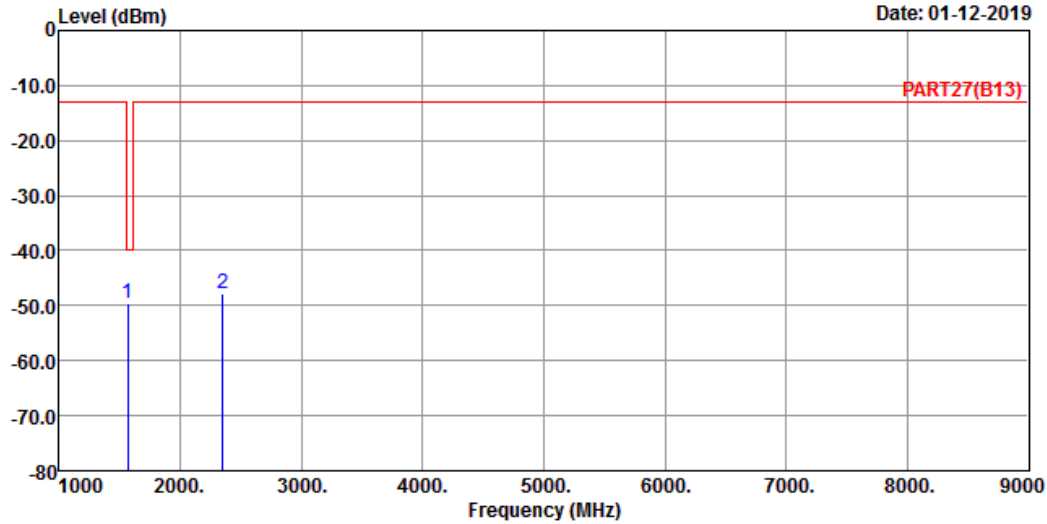

Site : 966 Chamber 5
 Condition: PART27(B13) VERTICAL
 Remak : Cat-M1 Band 13 QPSK_5M Link_M-CH
 Tested by: Thomas Wei

	Freq	Level	Read Level	Limit Line	Over Limit	Factor	Remark
	MHz	dBm	dBm	dBm	dB	dB	
1 pp	1564.00	-49.66	-36.32	-40.00	-9.66	-13.34	Peak
2	2346.00	-47.91	-38.47	-13.00	-34.91	-9.44	Peak

High Channel

Bureau Veritas Consumer Products Services Ltd., Taoyuan



A D T

Data: 1

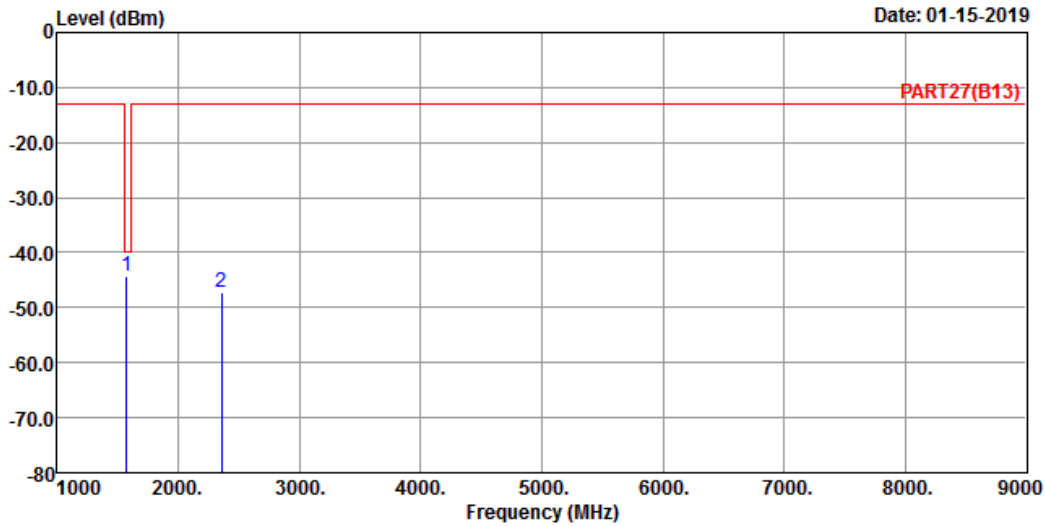

Site : 966 Chamber 5
 Condition: PART27(B13) HORIZONTAL
 Remak : Cat-M1 Band 13 QPSK_5M Link_H-CH
 Tested by: Thomas Wei

	Read	Limit	Over			
Freq	Level	Level	Line	Limit	Factor	Remark
MHz	dBm	dBm	dBm	dB	dB	
1 pp 1569.00	-44.41	-31.06	-40.00	-4.41	-13.35	Peak
2 2353.50	-47.29	-37.78	-13.00	-34.29	-9.51	Peak



Data: 2

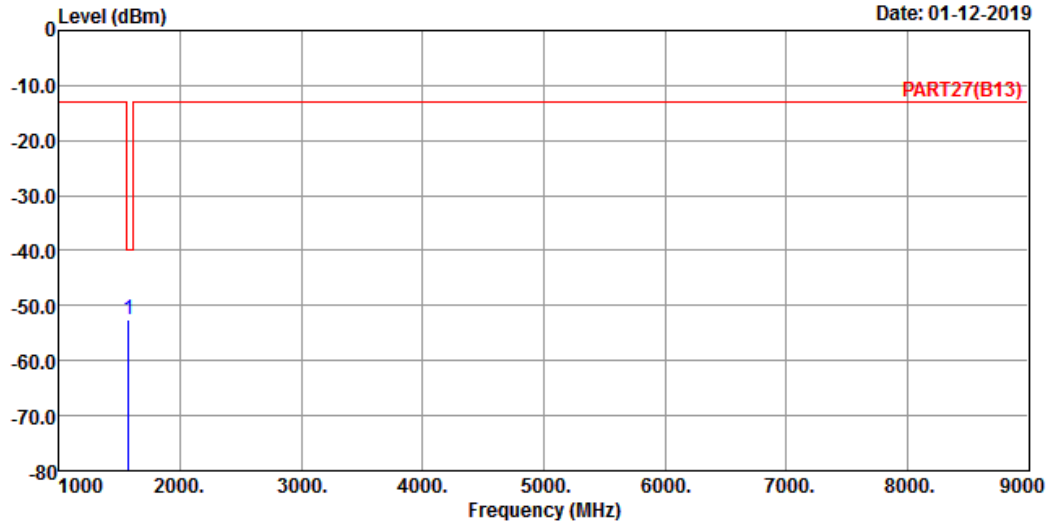

Site : 966 Chamber 5
 Condition: PART27(B13) VERTICAL
 Remak : Cat-M1 Band 13 QPSK_5M Link_H-CH
 Tested by: Thomas Wei

Freq	Level	Read Level	Limit Line	Over Limit	Factor	Remark
MHz	dBm	dBm	dBm	dB	dB	

1 pp 1569.00 -52.64 -39.29 -40.00 -12.64 -13.35 Peak

Channel Bandwidth: 10 MHz / QPSK

Bureau Veritas Consumer Products Services Ltd., Taoyuan



A D T

Data: 5

Date: 01-12-2019

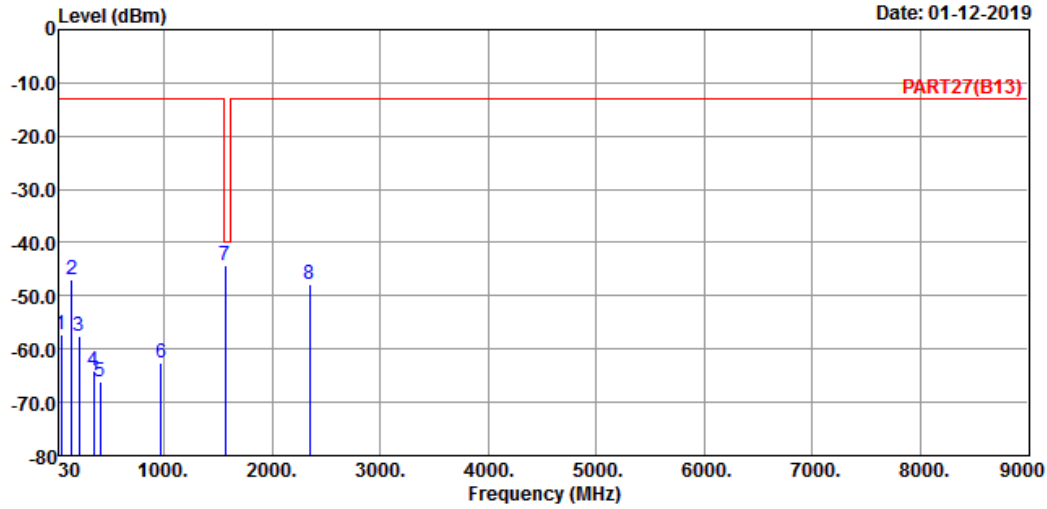

Site : 966 Chamber 5
 Condition: PART27(B13) HORIZONTAL
 Remak : Cat-M1 Band 13 QPSK_10M Link_M-CH
 Tested by: Thomas Wei

	Freq	Level	Read Level	Limit Line	Over Limit	Factor	Remark
	MHz	dBm	dBm	dBm	dB	dB	
1	43.58	-57.40	-55.93	-13.00	-44.40	-1.47	Peak
2	148.34	-47.00	-39.23	-13.00	-34.00	-7.77	Peak
3	214.30	-57.70	-50.26	-13.00	-44.70	-7.44	Peak
4	346.22	-64.07	-57.77	-13.00	-51.07	-6.30	Peak
5	407.33	-66.16	-60.27	-13.00	-53.16	-5.89	Peak
6	970.90	-62.44	-64.99	-13.00	-49.44	2.55	Peak
7 pp	1564.00	-44.19	-30.85	-40.00	-4.19	-13.34	Peak
8	2346.00	-47.75	-38.31	-13.00	-34.75	-9.44	Peak

Bureau Veritas Consumer Products Services Ltd., Taoyuan



A D T

Data: 6

Date: 01-12-2019

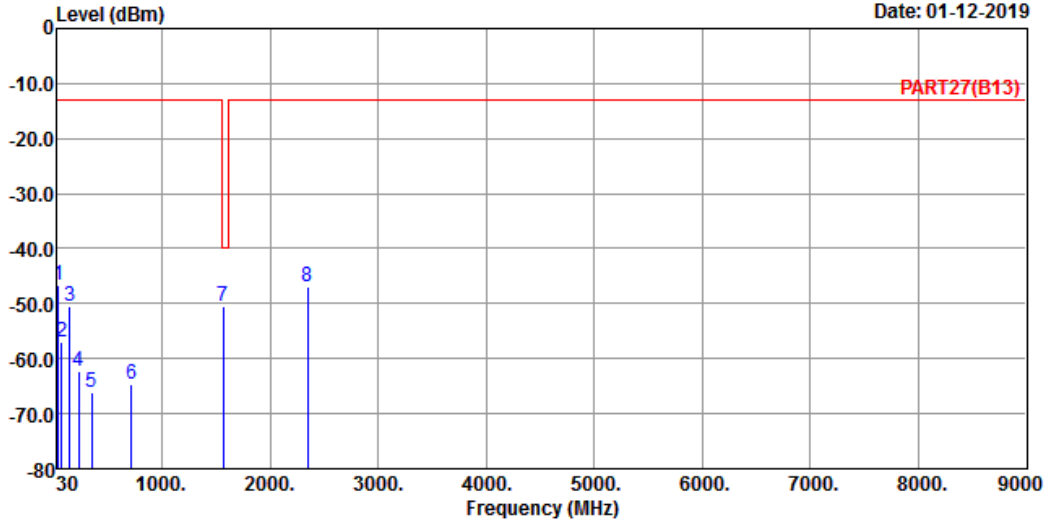

Site : 966 Chamber 5
 Condition: PART27(B13) VERTICAL
 Remak : Cat-M1 Band 13 QPSK_10M Link_M-CH
 Tested by: Thomas Wei

	Freq	Level	Read Level	Limit Line	Over Limit	Factor	Remark
	MHz	dBm	dBm	dBm	dB	dB	
1	42.61	-46.55	-45.61	-13.00	-33.55	-0.94	Peak
2	68.80	-56.89	-48.57	-13.00	-43.89	-8.32	Peak
3	147.37	-50.51	-42.64	-13.00	-37.51	-7.87	Peak
4	225.94	-62.43	-55.46	-13.00	-49.43	-6.97	Peak
5	344.28	-66.17	-59.84	-13.00	-53.17	-6.33	Peak
6	716.76	-64.66	-64.89	-13.00	-51.66	0.23	Peak
7 pp	1564.00	-50.45	-37.11	-40.00	-10.45	-13.34	Peak
8	2346.00	-47.08	-37.64	-13.00	-34.08	-9.44	Peak

5 Pictures of Test Arrangements

Please refer to the attached file (Test Setup Photo).

Appendix – Information of the Testing Laboratories

We, Bureau Veritas Consumer Products Services (H.K.) Ltd., Taoyuan Branch, were founded in 1988 to provide our best service in EMC, Radio, Telecom and Safety consultation. Our laboratories are FCC recognized accredited test firms and accredited according to ISO/IEC 17025.

If you have any comments, please feel free to contact us at the following:

Linko EMC/RF Lab

Tel: 886-2-26052180

Fax: 886-2-26051924

Hsin Chu EMC/RF/Telecom Lab

Tel: 886-3-6668565

Fax: 886-3-6668323

Hwa Ya EMC/RF/Safety

Tel: 886-3-3183232

Fax: 886-3-3270892

Email: service.adt@tw.bureauveritas.com

Web Site: www.bureauveritas-adt.com

The address and road map of all our labs can be found in our web site also.

--- END ---