

Turbo Mode (Channel 5) Peak data

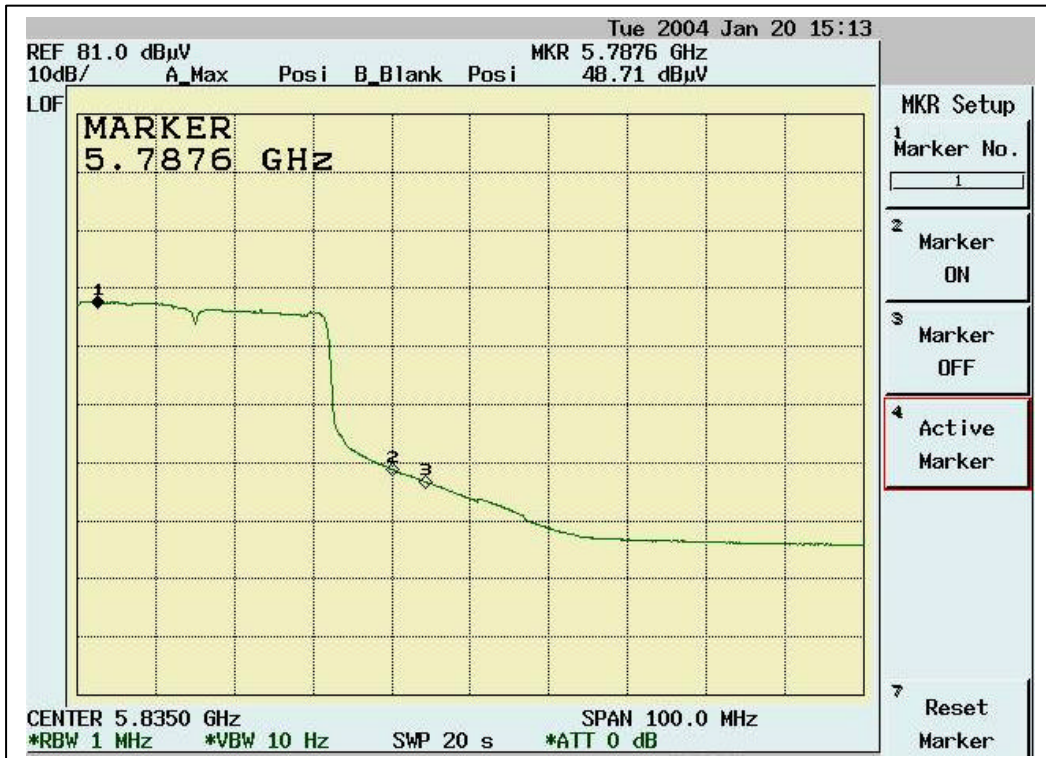

Turbo Mode (Channel 5) Average Data



**6.7 RF Exposure Measurement [Section 15.407(f)(4) & 1.1307(b)]**

See MPE report

### 6.8 Frequency Stability [Section 15.407(g)]

#### 6.8.1 Limits of Frequency Stability Measurement

The frequency tolerance of the carrier signal shall be maintained within +/- 0.02% of the operating frequency over the operation temperature range of EUT (0°C - 35°C), and variation in the primary supply voltage from 85% to 115% of the rated supply voltage (115V AC) at 20°C.

#### 6.8.2 Test Procedure

1. The EUT was placed in the Temperature/Humidity Chamber and powered by a Voltage/Frequency Power converter.
2. Connect the RF output of EUT to Spectrum. Turn on the EUT.
3. Turn the EUT off and set the chamber to the highest temperature specified.
4. Allow sufficient time (approximately 30 min) for the chamber temperature to stabilize. Turn the EUT on and measure the operating frequency after 2, 5, 10 minutes.
5. Set the Voltage/Frequency Power Converter to 85% and 115% of supply voltage, then repeat step 2, 3, 4 respectively.
6. Repeat step 2, 3, 4, 5 with the temperature of chamber set to the lowest temperature.
7. Repeat step 2, 3, 4, 5 with the temperature of chamber set to 20°C

#### 6.8.3 Test Setup

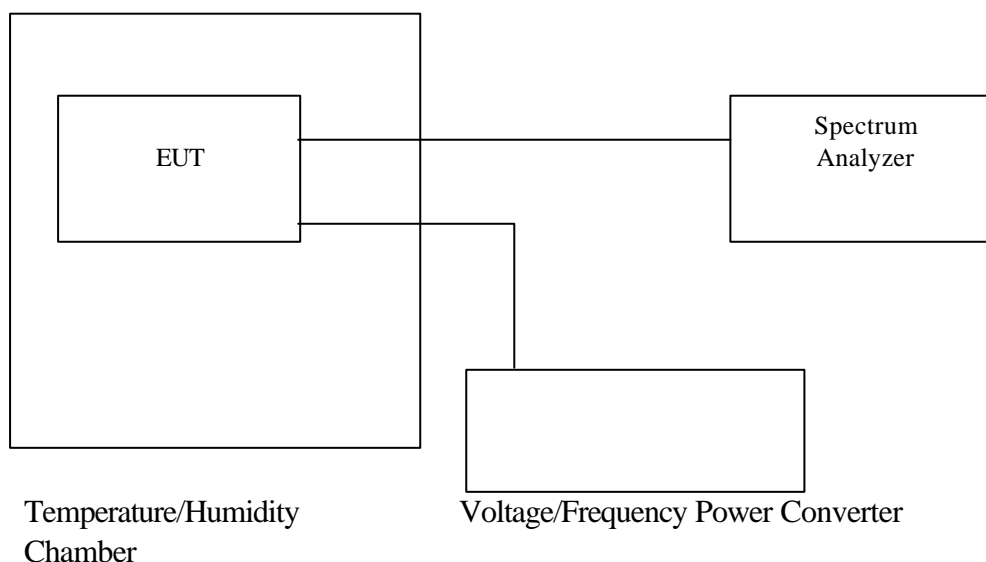

6.8.4 Test Data

Operating Frequency: 5180MHz		Limit: +/- 0.02%					
Temp. (°C)	Power Supply (V AC)	2 minutes		5 minutes		10 minutes	
		(MHz)	(%)	(MHz)	(%)	(MHz)	(%)
35	132	5179.9842	-0.000305	5179.9809	-0.000369	5179.9883	-0.000226
	115	5179.9876	-0.000239	5179.9897	-0.000199	5179.9891	-0.000210
	97	5179.9840	-0.000309	5179.9843	-0.000303	5179.9908	-0.000178
0	132	5179.9903	-0.000187	5179.9895	-0.000203	5179.9902	-0.000189
	115	5179.9873	-0.000245	5179.9910	-0.000174	5179.9932	-0.000131
	97	5179.9868	-0.000255	5179.9936	-0.000124	5179.9923	-0.000149
20	132	5179.9837	-0.000315	5179.9810	-0.000367	5179.9794	-0.000398
	115	5179.9817	-0.000353	5179.9808	-0.000371	5179.9836	-0.000317
	97	5179.9804	-0.000378	5179.9824	-0.000340	5179.9845	-0.000299

Operating Frequency: 5805 MHz		Limit: +/- 0.02%					
Temp. (°C)	Power Supply (V AC)	2 minutes		5 minutes		10 minutes	
		(MHz)	(%)	(MHz)	(%)	(MHz)	(%)
35	132	5804.9843	-0.000270	5804.9836	-0.000283	5804.9909	-0.000157
	115	5804.9790	-0.000362	5804.9874	-0.000217	5804.9948	-0.000090
	97	5804.9821	-0.000308	5804.9842	-0.000272	5804.9910	-0.000155
0	132	5804.9904	-0.000165	5804.9846	-0.000265	5804.9886	-0.000196
	115	5804.9882	-0.000203	5804.9841	-0.000274	5804.9941	-0.000102
	97	5804.9940	-0.000103	5804.9919	-0.000140	5804.9897	-0.000177
20	132	5804.9842	-0.000272	5804.9767	-0.000401	5804.9775	-0.000388
	115	5804.9789	-0.000363	5804.9790	-0.000362	5804.9786	-0.000369
	97	5804.9794	-0.000355	5804.9830	-0.000293	5804.9803	-0.000339

## 7. Appendix

### 7.1 Appendix A: Measurement Procedure for Power line Conducted Emissions

The EUT is set up in accordance with the suggested configuration given in ANSI C63.4-2001, CFR 47 Part 15 Subpart B; or EN55022:1994/ A1:1995/A2:1997; CISPR 22:1993/A1:1995/A2:1996. The measurements are performed in a 3.5m x 3.4m x 2.5m shielded room, which referred as Conduction 01 test site, or a 3m x 3m x 2.3m test site, which referred as Conduction 02 test site. The EUT was placed on non-conduction 1.0m x 1.5m table, which is 0.8 meters above an earth-grounded.

Power to the EUT was provided through the LISN which has the Impedance (50ohm/50uH) vs. Frequency Characteristic in accordance with the Figure 1 of the ANSI C63.4-2001 or CISPR16. Power to the LISNs were filtered to eliminate ambient signal interference and these filters were bonded to the ground plane. Peripheral equipment required to provide a functional system (support equipment) for EUT testing was powered from the second LISN through a ganged, metal power outlet box which is bonded to the ground plane at the LISN.

If the EUT is supplied with a flexible power cord, the power cord length in excess of the distance separating the EUT from the LISN shall be folded back and forth at the center of the lead so as to form a bundle not exceeding 40cm in length. If the EUT is provided with a permanently coiled power cord, bundling of the cord is not required. If the EUT is supplied without a power cord, the EUT shall be connected to the LISN by a power cord of the type specified by the manufacturer which shall not be longer than 1 meter. The excess power cord shall be bundled as described above. If a non-flexible power cord is provided with the EUT, it shall be cut to the length necessary to attach the EUT to the LISN and shall not be bundled.

The interconnecting cables were arranged and moved to get the maximum according to ANSI C63.4-2001, CFR 47 Part 15 Subpart B; or EN55022:1994/ A1:1995/A2:1997; CISPR 22:1993/A1:1995/A2:1996. Both the line of power cord, hot and neutral, were measured.

The highest emissions were analyzed in details by operating the spectrum analyzer in fixed tuned mode to determine the nature of the emissions and to provide information which could be useful in reducing their amplitude.

## 7.2 Appendix B: Test Procedure for Radiated Emissions

### Preliminary Measurements in the Anechoic Chamber

The radiated emissions are initially measured in the anechoic chamber at a measurement distance of 3 meters. Desktop EUT are placed on a wooden stand 0.8 meter in height. The measurement antenna is 3 meters from the EUT. The test setup in anechoic chamber is the same as open site. The turntable rotated 360°C. The antenna height is varied from 1-2.5m. The primary objective of the radiated measurements in the anechoic chamber is to identify the frequency spectrum in the absence of the electromagnetic environment existing on the open test site. The frequencies can then be pre-selected on the open test site to obtain the corresponding amplitude. The initial scan is made with the spectrum analyzer in automatic sweep mode. The spectrum peaks are then measured manually to determine the exact frequencies.

### Measurements on the Open Site or 10m EMC Chamber

The radiated emissions test will then be repeated on the open site or 10m EMC chamber to measure the amplitudes accurately and without the multiple reflections existing in the shielded room. The EUT and support equipment are set up on the turntable of one of the 3 or 10 meter open field sites. Desktop EUT are set up on a wooden stand 0.8 meter above the ground.

For the initial measurements, the receiving antenna is varied from 1-4 meter height and is changed in the vertical plane from vertical to horizontal polarization at each frequency. Both reading are recorded with the quasi-peak detector with 120KHz bandwidth. For frequency between 30 MHz and 1000MHz, the reading is recorded with peak detector or quasi-peak detector. For frequency above 1 GHz, the reading is recorded with peak detector or average detector with 1 MHz bandwidth.

At the highest amplitudes observed, the EUT is rotated in the horizontal plane while changing the antenna polarization in the vertical plane to maximize the reading. The interconnecting cables were arranged and moved to get the maximum according to ANSI C63.4-2001, CFR 47 Part 15 Subpart B; or EN55022:1994/ A1:1995/A2:1997; CISPR 22:1993/A1:1995/A2:1996. Once the maximum reading is obtained, the antenna elevation and polarization will be varied between specified limits to maximize the readings.

## 7.3 Appendix C: Test Equipment

### 7.3.1 Test Equipment List

Location	Equipment Name	Brand	Model	S/N	Last Cal. Date	Next Cal. Date
Conduction	Digital Hygro-Thermometer Conduct	MicroLife	HT-2126G	ISL-Conducti on02	12/04/2003	12/04/2004
Conduction	50 Ohms Load Conduction 02	EMCO	N/A	ISL-50ohms conduction 02	11/21/2003	11/21/2004
Conduction	Coaxial Cable 1F-C2	Harbourindu stries	RG400	1F-C2	06/03/2003	06/03/2004
Conduction	EMI Receiver 02	HP	85460A	3448A00183	08/21/2003	08/21/2004
Conduction	ISN T4	Schaffner	ISN T400	16593	08/20/2002	08/20/2004
Conduction	ISN T4 02	FCC	F-CMISN-C AT5	02003	12/17/2003	12/17/2004
Conduction	CISPR22 Voltage Probe	FCC	F-CVP-1	68	12/18/2003	12/18/2004
Conduction	Current Probe	Schaffner	SMZ 11	18030	01/09/2003	01/09/2004
Conduction	LISN 01	R&S	ESH2-Z5	890485/013	05/07/2003	05/07/2004
Conduction	LISN 04	EMCO	3810/2	9604-1429	12/17/2003	12/16/2004
Radiation	Digital Hygro-Thermometer Chmb 02	MicroLife	HT-2126G	Chmb 02	12/04/2003	12/04/2004
Radiation	Spectrum Analyzer 06	Advantest	R3162	91700295	09/25/2003	09/24/2004
Radiation	EMI Receiver 04	AFJ	ER 55CR	55390143233	10/28/2003	10/27/2004
Radiation	BILOG Antenna 08	Schaffner	CBL6112B	2756	06/04/2003	06/04/2004
Radiation	Coaxial Cable Chmb 02-10M	Belden	RG-8/U	Chmb 02-10M	10/03/2003	10/03/2004
Radiation	Microwave Cable Chmb 02 3M	HUBER+SU HNER AG	Sucoflex 103	42731/3 & 42729/3	03/21/2003	03/21/2004
Radiation	Temperature/ Humility Chamber	K. Son Ins. Tech.	THS-B4H <sup>+</sup> - 100	2287	03/01/2003	03/01/2004
Radiation	Voltage/Frequency Power converter	EXTECH Electronics	CFC-105W	780274	08/25/2003	08/25/2004
Rad. Above 1Ghz	Spectrum Analyzer 07	Advantest	R3182	110600649	10/17/2003	10/17/2004
Rad. Above 1Ghz	Horn Antenna 02	Com-Power	AH-118	10088	02/06/2003	02/05/2004
Rad. Above 1Ghz	Horn Antenna 04	Com-Power	AH-826	081-001	12/10/2003	12/09/2004
Rad. above 1Ghz	Horn Antenna 05	Com-Power	AH-640	100A	09/13/2003	09/13/2004
Rad. above 1Ghz	Microwave Cable Chmb 05	HUBER+SU HNER AG.	Sucoflex 103	42726/3 & 42727/3	09/11/2003	09/11/2004

Location	Equipment Name	Brand	Model	S/N	Last Cal. Date	Next Cal. Date
Rad. Above 1Ghz	Preamplifier 02	MITEQ	AFS44-00102 650-40-10P-4 4	728229	05/07/2003	05/07/2004
Rad. Above 1Ghz	Preamplifier 09	MITEQ	AFS44-00102 650-40-10P-4 4	858687	02/28/2003	02/28/2004
Rad. Above 1Ghz	Preamplifier 10	MITEQ	JS-26004000- 27-5A	818471	02/28/2003	02/28/2004
Rad. Above 1Ghz	Signal Generator 03	Anritsu	MG3642A	6200162550	02/10/2003	02/09/2004
Rad. Above 1Ghz	Signal Generator 04	Anritsu	MG3692A	020311	02/06/2003	02/06/2004
Rad. Above 1Ghz	Peak Power Analyzer	HP	8990A	3621A01269	12/09/2003	12/09/2004
Rad. Above 1Ghz	Power Sensor Radar	HP	84815A	3318A01828	11/12/2003	11/12/2004

Note: Calibration traceable to NIST or national or international standards.

### 7.3.2 Software for Controlling Spectrum/Receiver and Calculating Test Data

Radiation/Conduction	Filename	Version	Issued Date
Conduction	Tile.exe	1.12E	7/7/2000
Radiation	Tile.exe	1.12C	6/16/2000



### 7.4 Appendix D: Layout of EUT and Support Equipment

#### 7.4.1 General Conducted Test Configuration

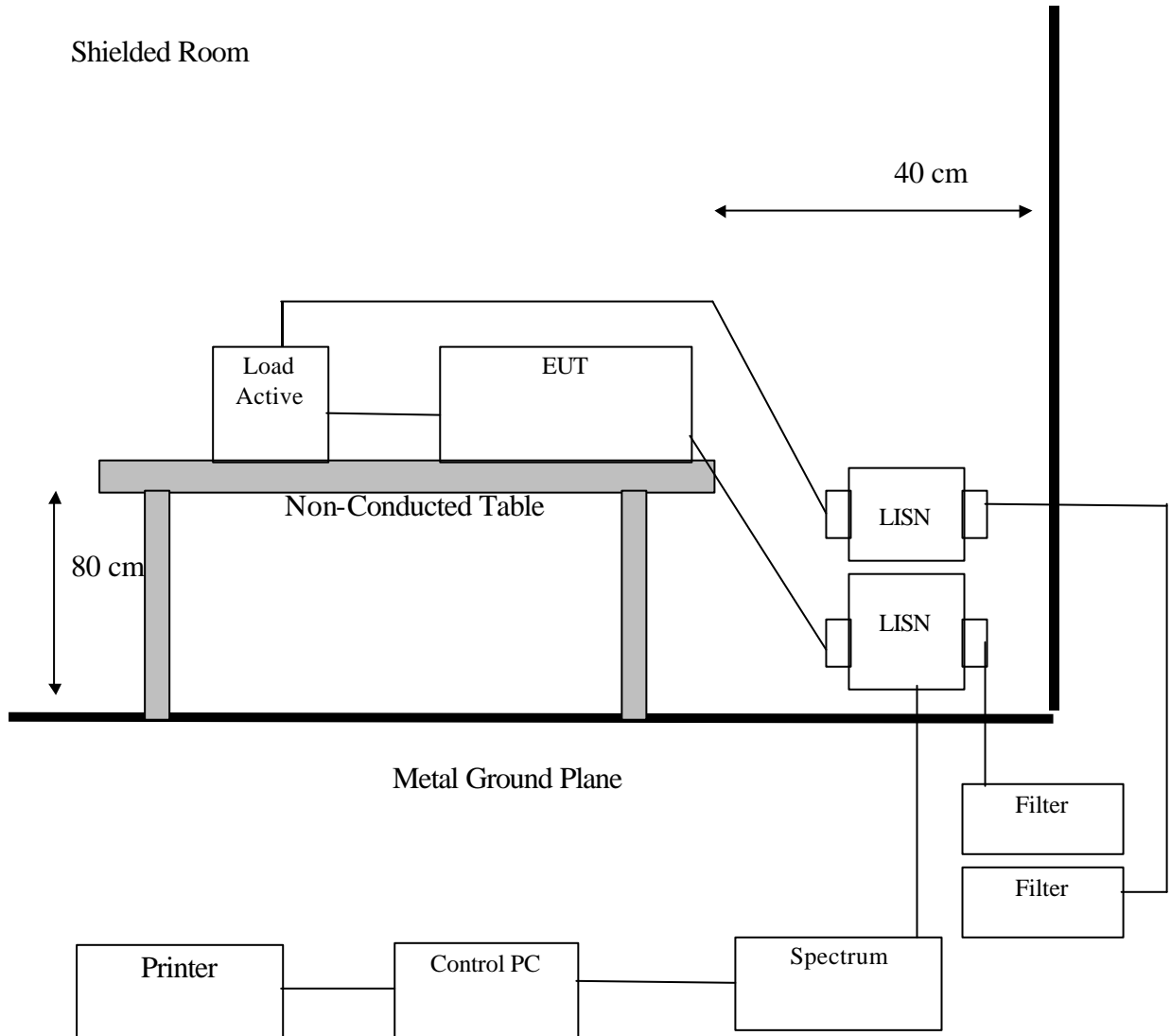

### 7.4.2 General Radiation Test Configuration

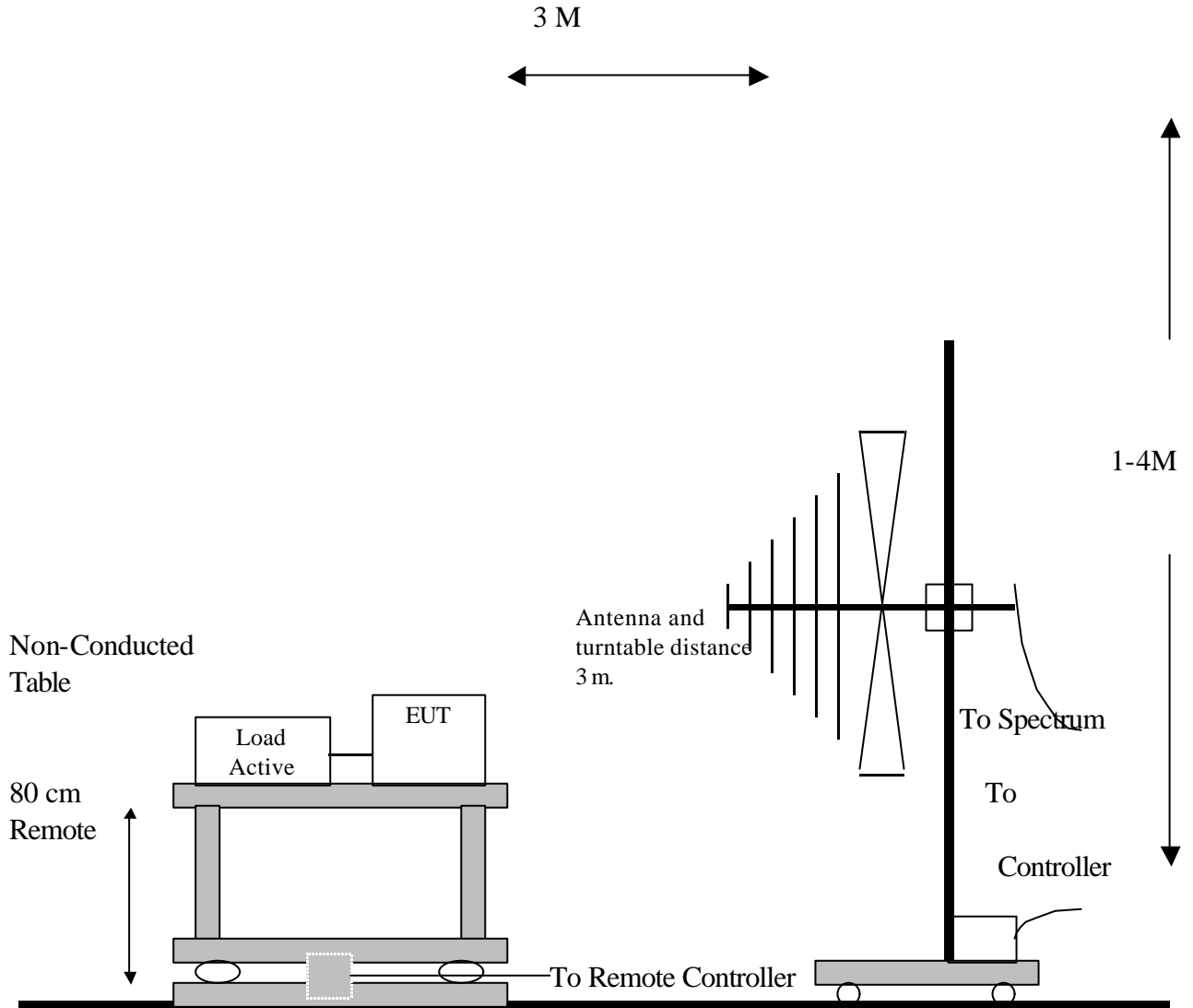

Metal Full Soldered Ground Plane

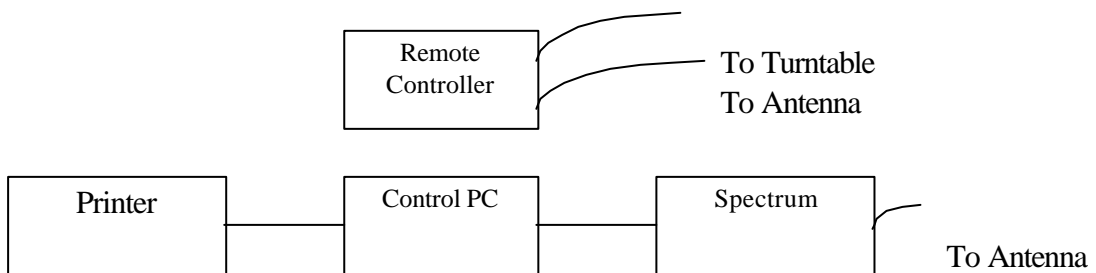

## 7.5 Appendix E: Description of Support Equipment

### 7.5.1 Description of Support Equipment

#### Support Unit 1.

Description:	Acer USB Keyboard
Model Number:	6511-UV
Serial Number:	N/A
Power Supply Type:	N/A
Power Cord:	N/A
FCC ID:	N/A (comply with FCC DOC)

#### Support Unit 2.

Description:	Acer Monitor
Model:	G781
Serial Number:	999007101214400445T7AA31T
Power Cord:	Non-shielded, Detachable
FCC ID:	(Comply with FCC Standards)

### Support Unit 3.

Description:	Notebook Personal Computer
Model No.:	DT3
Adapter Type:	Auto Switch/ Lite-On (Model: PA-1181-08QA) 3 Pins
Hard Disk Driver:	Seagate HDD(ALPINE 120G)ST3120022A
LCD:	QDI 17" SXGA ( QDI/ QD17EL07 )
DVD ROM Driver:	QSI 8X DVD-ROM, Slim, SDR-083
CD-RW/DVD Driver:	QSI 8X DVD- Combo, Slim, SBW-242
DVD Dual Driver:	Pioneer DVD Dual DVR-K12D
DDR SDRAM:	Infineon 512MB/ HYS64D64320GU-5-B Infineon 256MB/ HYS64D32300GU-5-B Nanya 512MB/ NT512D64S8HB1G-5T Nanya 256MB/ NT256D64S88B1G-5T
Parallel Connector:	one 25-pins
VGA Connector:	one 15-pins
TV Out:	one 4-pins
USB Connector:	Four 4-pins
1394 Connector:	Two 4-pins
RJ11 Connector:	one 2-pins
RJ45 Connector:	one 8-pins
Mic-in Port:	one
Headphone-out Port:	one
PCMCIA Slot:	one
MS/SD/MMC Slot:	one
DC IN Port:	one
Battery:	Simplo/ BATT PACK LI 916-2600(DT1,4S3P,6.6A)
Power Cord:	Nonshielded, Detachable
Speed & CPU:	
Speed	CPU
133MHz	Pentium IV 2.66GHz

### 7.5.2 Software for Controlling Support Unit

Test programs exercising various part of EUT were used. The programs were executed as follows:

- A. Read and write to the disk drives.
- B. Send H pattern to the video port device (Monitor).
- C. Repeat the above steps.

	Filename	Issued Date
Monitor	HH.bat	8/20/1991

### 7.5.3 I/O Cable Condition of EUT and Support Units

Description	Path	Cable Length	Cable Type	Connector Type
AC Power Cord	110V (~240V) to AC Power Cord Inlet (3-pin)	1.8M	Nonshielded, Detachable	Plastic Head
Monitor Data Cable	Monitor to PC VGA port	1.6M	Shielded, Un-detachable	Metal Head
USB Mouse Data Cable	USB Mouse to PC USB port	1.8M	Shielded, Un-detachable	Metal Head

**7.6 Appendix F: Accuracy of Measurement**

Test Site: Conduction 02

Item	Source of Uncertainty	Probability Distribution	Total Uncertainties (dB)		Standard Uncertainty (dB)	
1	Systematic Effects: (Assessment from 20 repeat observation; 1 reading on EUT)	Normal	k=2	0.104	k=1	0.052
2	Random Effects: (Assessment from 20 random observations; 1 reading on EUT)	Normal	k=2	0.330	k=1	0.165
3	Receiver Calibration	Rectangular	k=1.73	1.000	k=1	0.577
4	LISN Factor Calibration	Normal	k=2	1.200	k=1	0.600
5	Cable Loss Calibration	Normal	k=2	1.000	k=1	0.500
6	Combined Standard Uncertainty Uc(y)	Normal			k=1	0.850
7	<b>Total Uncertainty @95% mim. Confidence Level</b>	<b>Normal</b>	<b>k=2</b>	<b>1.701</b>		

Measurement Uncertainty Calculations:

$$U_c(y) = \text{square root} ( u_1(y)^2 + u_2(y)^2 + \dots + u_n(y)^2 )$$

$$U = 2 * U_c(y)$$

Note: The measurement Uncertainties mentioned above also refer to NIS 81-1994 of NAMAS :  
The treatment of Uncertainty in EMC Measurement.

Test Site: Chamber 02-3M

Item	Source of Uncertainty	Probability Distribution	Total Uncertainties (dB)		Standard Uncertainty (dB)	
			k	Value	k	Value
1	Systematic Effects: (Assessment from 20 repeat observation; 1 reading on EUT)	Normal	k=2	0.067	k=1	0.034
2	Random Effects: (Assessment from 20 random observations; 1 reading on EUT)	Normal	k=2	0.103	k=1	0.052
3	Receiver Calibration	Rectangular	k=1.73	1.000	k=1	0.577
4	Antenna Factor Calibration	Normal	k=2	1.700	k=1	0.850
5	Cable Loss Calibration	Normal	k=2	1.000	k=1	0.500
6	Combined Standard Uncertainty Uc(y)	Normal			k=1	1.029
7	<b>Total Uncertainty @95% mim. Confidence Level</b>	<b>Normal</b>	<b>k=2</b>	<b>2.059</b>		

Measurement Uncertainty Calculations:

$$Uc(y) = \text{square root} ( u_1(y)^2 + u_2(y)^2 + \dots + u_n(y)^2 )$$

$$U = 2 * Uc(y)$$

Note: The measurement Uncertainties mentioned above also refer to NIS 81-1994 of NAMAS :  
The treatment of Uncertainty in EMC Measurement.

### 7.7 Appendix G: Photographs of EUT Configuration Test Set Up

The Front View of Highest Conducted Set-up For EUT

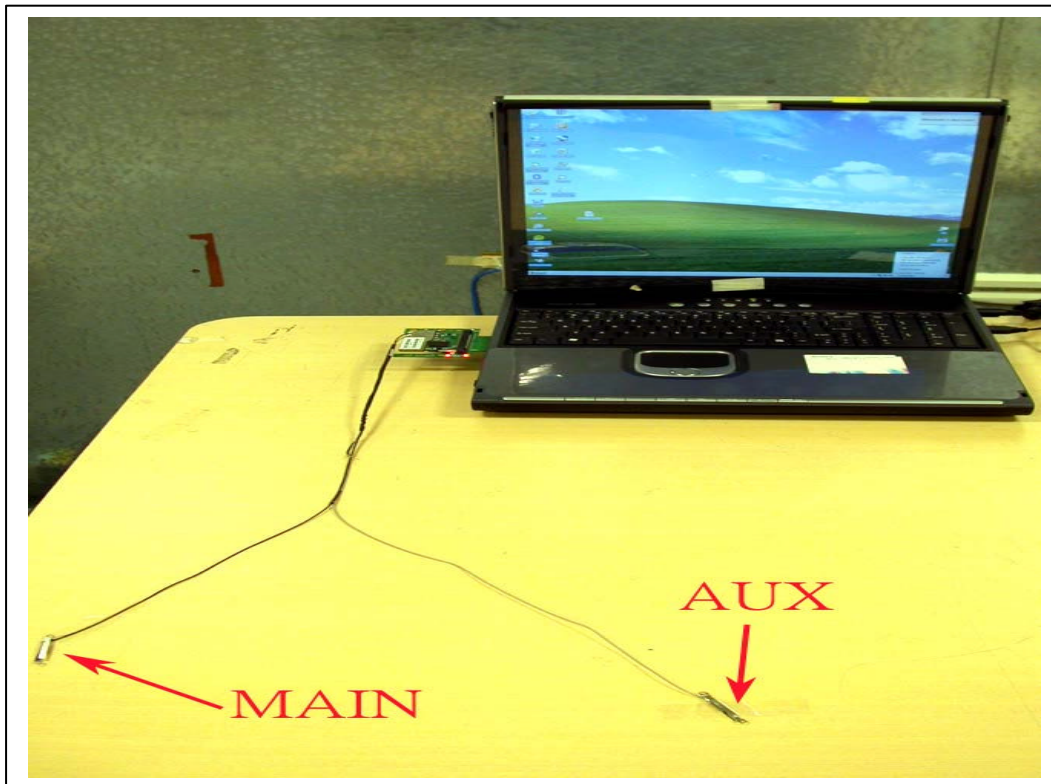



The Front View of Highest Radiated Set-up For EUT



The Back View of Highest Radiated Set-up For EUT

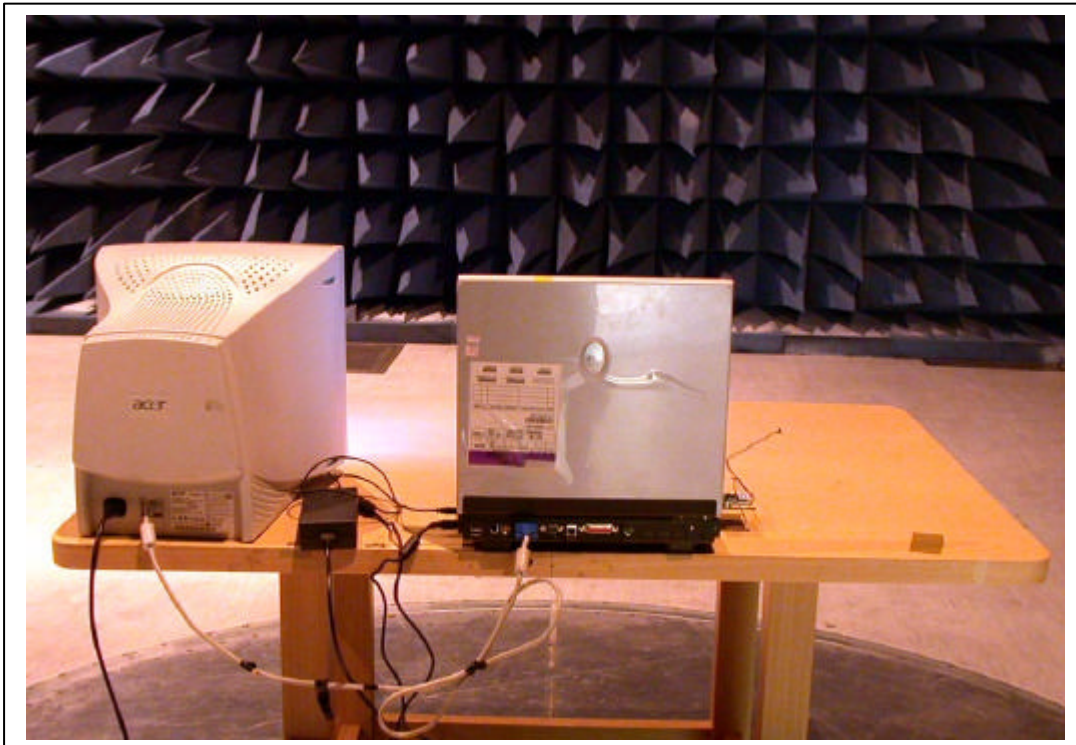

## **7.8 Appendix H: Antenna Spec.**

Please refer to the attached file.