



Test Report
for
FCC Part 15 Subpart B & C

of

Product Name

802.11g USB 2.0 adapter

Model

DRUC-U3

Applied by:

Wistron Neweb Corporation
No. 10-1, Li-hsin Road 1,
Science-based Industrial Park, Hsinchu 300,
Taiwan, R. O. C.

Test Performed by:

International Standards Laboratory

No. 120, Lane 180, San Ho Tsuen, Hsin Ho Rd.
Lung-Tan Hsiang, Tao Yuan County 325
Taiwan, R.O.C.
Tel:(03)407-1718 Fax:(03)407-1738

Report Number: ISL-06LR014FC

Issue Date: 2006/05/11

HC LAB: NVLAP:200234-0; VCCI: R-341,C-354; NEMKO:ELA 113A; BSMI:SL2-IN-E-0037; SL2-R1-E-0037; CNLA:1178; IC:IC4067
LT LAB: NVLAP:200234-0; VCCI: R-1435,C-1440; NEMKO:ELA 113B; CNLA:0997; IC:IC4164-1

ISL-T10-R2-3

Contents of Report

1.	General.....	1
1.1	Certification of Accuracy of Test Data	1
2.	Test Results Summary	2
3.	Description of Equipment Under Test (EUT)	3
4.	TEST RESULTS (802.11b).....	4
4.1	Powerline Conducted Emissions [Section 15.207]	4
4.1.1	EUT Configuration	4
4.1.2	Test Procedure	4
4.1.3	EMI Receiver/Spectrum Analyzer Configuration (for the frequencies tested) .	4
4.1.4	Test Data:.....	5
4.2	Bandwidth for DSSS [Section 15.247 (a)(2)].....	7
4.2.1	Test Procedure	7
4.2.2	Test Setup	7
4.2.3	Test Data:.....	7
4.3	DSSS Maximum Peak Output Power [Section 15.247 (b)(1)].....	10
4.3.1	Test Procedure	10
4.3.2	Test Setup	10
4.3.3	Test Data.....	10
4.4	Radiated Emission Measurement [Section [15.247(c)(4)]	11
4.4.1	EUT Configuration	11
4.4.2	Test Procedure	11
4.4.3	EMI Receiver/Spectrum Analyzer Configuration (for the frequencies tested)	11
4.4.4	Test Data (30MHz – 1GHz):	12
4.4.5	Test Data (1GHz – 25 GHz)	13
4.5	Band Edge Measurement.....	16
4.5.1	Test Procedure (Conducted)	16
4.5.2	Test Setup (Conducted)	16
4.5.3	Test Data:.....	16
4.5.4	Test Procedure (Radiated)	18
4.5.5	Test Setup (Radiated).....	18
4.5.6	Test Data	19
4.6	RF Exposure Measurement [Section 15.247(b)(4) & 1.1307(b)].....	22
4.7	DSSS Peak Power Spectral Density [Section 15.247(d)].....	23
4.7.1	Test Procedure	23
4.7.2	Test Setup	23
4.7.3	Test Data.....	23
5.	TEST RESULTS (802.11g).....	26
5.1	Powerline Conducted Emissions [Section 15.207]	26
5.1.1	EUT Configuration	26
5.1.2	Test Procedure	26
5.1.3	EMI Receiver/Spectrum Analyzer Configuration (for the frequencies tested)	26



5.1.4 Test Data:..... 27

5.2 Bandwidth for DSSS [Section 15.247 (a)(2)]..... 29

5.2.1 Test Procedure 29

5.2.2 Test Setup 29

5.2.3 Test Data:..... 29

5.3 DSSS Maximum Peak Output Power [Section 15.247 (b)(1)]..... 32

5.3.1 Test Procedure 32

5.3.2 Test Setup 32

5.3.3 Test Data 32

5.4 Radiated Emission Measurement [Section [15.247(c)(4)] 33

5.4.1 EUT Configuration 33

5.4.2 Test Procedure 33

5.4.3 EMI Receiver/Spectrum Analyzer Configuration (for the frequencies tested) 33

5.4.4 Test Data (30MHz – 1GHz): 34

5.4.5 Test Data (1GHz – 25 GHz) 35

5.5 Band Edge Measurement..... 38

5.5.1 Test Procedure (Conducted) 38

5.5.2 Test Setup (Conducted) 38

5.5.3 Test Data:..... 38

5.5.4 Test Procedure (Radiated) 40

5.5.5 Test Setup (Radiated)..... 40

5.5.6 Test Data 41

5.6 RF Exposure Measurement [Section 15.247(b)(4) & 1.1307(b)]..... 44

5.7 DSSS Peak Power Spectral Density [Section 15.247(d)]..... 45

5.7.1 Test Procedure 45

5.7.2 Test Setup 45

5.7.3 Test Data 45

6. Appendix 48

6.1 Appendix A: Measurement Procedure for Power line Conducted Emissions..... 48

6.2 Appendix B: Test Procedure for Radiated Emissions 49

6.3 Appendix C: Test Equipment 50

6.3.1 Test Equipment List..... 50

6.3.2 Software for Controlling Spectrum/Receiver and Calculating Test Data 50

6.4 Appendix D: Layout of EUT and Support Equipment 51

6.4.1 General Conducted Test Configuration 51

6.4.2 General Radiation Test Configuration..... 52

6.5 Appendix E: Description of Support Equipment..... 53

6.5.1 Description of Support Equipment 53

6.5.2 Software for Controlling Support Unit 54

6.5.3 I/O Cable Condition of EUT and Support Units..... 55

6.6 Appendix F: Accuracy of Measurement..... 56

6.7 Appendix G: Photographs of EUT Configuration Test Set Up..... 58

6.8 Appendix H: Antenna Spec. 61



1. General

1.1 Certification of Accuracy of Test Data

Standards: CFR 47 Part 15 Subpart B Class B
CFR 47 Part 15 Subpart C (Section 15.247)

Test Procedure: ANSI C63.4:2003

Equipment Tested: 802.11g USB 2.0 adapter

Model: DRUC-U3

Applied by: Wistron Neweb Corporation

Sample received Date: 2006/05/10

Final test Date : 2006/05/11

Test Result PASS

Test Site: Chamber 02, Conduction 02

Temperature Refer to each site test data

Humidity: Refer to each site test data

Test Engineer:

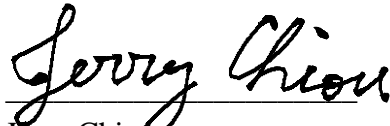
Jerry Chiou

All the tests in this report have been performed and recorded in accordance with the standards described above and performed by an independent electromagnetic compatibility consultant, International Standards Laboratory.

The test results contained in this report accurately represent the measurements of the characteristics and the energy generated by sample equipment under test at the time of the test. The sample equipment tested as described in this report is in compliance with the limits of above standards.

Approve & Signature

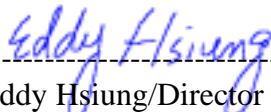

Eddy Hsiung/Director

Test results given in this report apply only to the specific sample(s) tested under stated test conditions. This report shall not be reproduced other than in full without the explicit written consent of ISL. This report totally contains 64 pages, including 1 cover page, 2 contents page, and 61 pages for the test description. This report must not be use to claim product endorsement by NVLAP or any agency of the U.S. Government.

This test data shown below is traceable to NIST or national or international standard. International Standards Laboratory certifies that no party to this application has been denied the FCC benefits pursuant to Section 5301 of the Anti-Drug Abuse Act of 1988, 21 U.S.C. 853(a).

2. Test Results Summary

The 802.11b functions of EUT has been tested according to the FCC regulations listed below:

Tested Standards: 47 CFR Part 15 Subpart C			
Standard Section	Test Type	Result	Remarks
15.207	AC Power Line Emissions	Pass	
15.247(a)(2)	Spectrum Bandwidth Of DSSS device	Pass	
15.247(b)	Max. Peak Output Power	Pass	
15.247(c)	Radiated Emissions 30MHz – 25 GHz	Pass	
15.247 (c)	Band Edge Measurement	Pass	
15.247(b)(4)	Radiation Exposure	Pass	SAR report attached
15.247 (d)	Power Spectral Density	Pass	

The 802.11g functions of EUT has been tested according to the FCC regulations listed below:

Tested Standards: 47 CFR Part 15 Subpart C			
Standard Section	Test Type	Result	Remarks
15.207	AC Power Line Emissions	Pass	
15.247(a)(2)	Spectrum Bandwidth Of DSSS device	Pass	
15.247(b)	Max. Peak Output Power	Pass	
15.247(c)	Radiated Emissions 30MHz – 25 GHz	Pass	
15.247 (c)	Band Edge Measurement	Pass	
15.247(b)(4)	Radiation Exposure	Pass	SAR report attached
15.247 (d)	Power Spectral Density	Pass	

3. Description of Equipment Under Test (EUT)

Description:	802.11g USB2.0 adapter
Condition:	Pre-Production
Model:	DRUC-U3
Frequency Range 802.11b/g:	2400 - 2483.5 MHz
Support channel: 802.11b/g	11 Channels
Modulation Skill: 802.11b	DBPSK(1Mbps), DQPSK(2Mbps), CCK(5.5/11Mbps)
802.11g	OFDM (6M - 54Mbps)
Antennas Type:	Dual band printed IFA type made by Wistron NeWeb Corp.
Antenna peak Gain:	0.92 dBi
Antenna Connected:	The Antenna is layout in the PCB of the WLAN module, the user is not possible to change the antenna.
Power Type:	3.3V DC from Notebook PC

The EUT is an 802.11g USB 2.0 adapter .

The channel and the operation frequency of 802.11b and 802.11g are listed below:

Channel	Frequency(MHz)	Channel	Frequency(MHz)
01	2412	07	2442
02	2417	08	2447
03	2422	09	2452
04	2427	10	2457
05	2432	11	2462
06	2437		

All types of the transmit data rate have been tested, we present the worst case test data in the report.

4. TEST RESULTS (802.11b)

4.1 Powerline Conducted Emissions [Section 15.207]

4.1.1 EUT Configuration

The EUT was set up on the non-conductive table that is 1.0 by 1.5 meter, 80cm above ground. The wall of the shielded room was located 40cm to the rear of the EUT.

Power to the EUT was provided through the LISN. The impedance vs. frequency characteristic of the LISN is complied with the limit used.

Both lines (neutral and hot) were connected to the LISN in series at testing. A coaxial-type connector which provides one 50 ohms terminating impedance was provided for connecting the test instrument. The excess length of the power cord was folded back and forth at the center of the lead so as to form a bundle not exceeding 40cm in length.

Any changes made to the configuration, or modifications made to the EUT, during testing are noted in the following test record.

If the EUT is a Personal Computer or a peripheral of personal computer, and the personal computer has an auxiliary AC outlet which can be used for providing power to an external monitor, then all measurements will be made with the monitor power from first the computer-mounted AC outlet and then a floor-mounted AC outlet.

4.1.2 Test Procedure

The system was set up as described above, with the EMI diagnostic software running. The main power line conducted EMI tests were run on the hot and neutral conductors of the power cord and the results were recorded. The effect of varying the position of the interface cables has been investigated to find the configuration that produces maximum emission.

At the frequencies where the peak values of the emissions were higher than 6dB below the applicable limits, the emissions were also measured with the quasi-peak detectors. At the frequencies where the quasi-peak values of the emissions were higher than 6dB below the applicable average limits, the emissions were also measured with the average detectors.

The highest emissions were analyzed in details by operating the spectrum analyzer in fixed tuned mode to determine the nature of the emissions and to provide information which could be useful in reducing their amplitude.

4.1.3 EMI Receiver/Spectrum Analyzer Configuration (for the frequencies tested)

Frequency Range	150 KHz--30MHz
Detector Function	Quasi-Peak/Average
Bandwidth (RBW)	9KHz

4.1.4 Test Data:

Power Line Conducted Emissions (Hot) Channel 1, 6, 11

Operator: Jerry Chiou
 Temperature (C): 25
 Humidity (%): 56

Frequency	LISN Loss	Cable Loss	QP Corrct.	QP Limit	QP Margin	AVE Corrct.	AVE Limit	AVE Margin
MHz	(dB)	(dB)	Amp.(dBuV)	(dBuV)	(dB)	Amp.(dBuV)	(dBuV)	(dB)
0.22133	0.11	0.06	43.36	63.96	-20.60	30.30	53.96	-23.66
0.66536	0.20	0.07	33.99	56.00	-22.01	21.98	46.00	-24.02
0.77228	0.20	0.07	37.44	56.00	-18.56	27.13	46.00	-18.88
0.83748	0.20	0.07	39.90	56.00	-16.10	33.81	46.00	-12.19
0.94298	0.20	0.07	39.78	56.00	-16.22	34.12	46.00	-11.88
1.19145	0.22	0.07	29.94	56.00	-26.06	22.40	46.00	-23.60
1.3893	0.24	0.08	34.84	56.00	-21.16	22.65	46.00	-23.35
1.69776	0.27	0.08	32.99	56.00	-23.01	23.36	46.00	-22.64
2.36459	0.32	0.10	35.64	56.00	-20.36	28.82	46.00	-17.18
3.69173	0.38	0.13	35.44	56.00	-20.56	28.06	46.00	-17.94

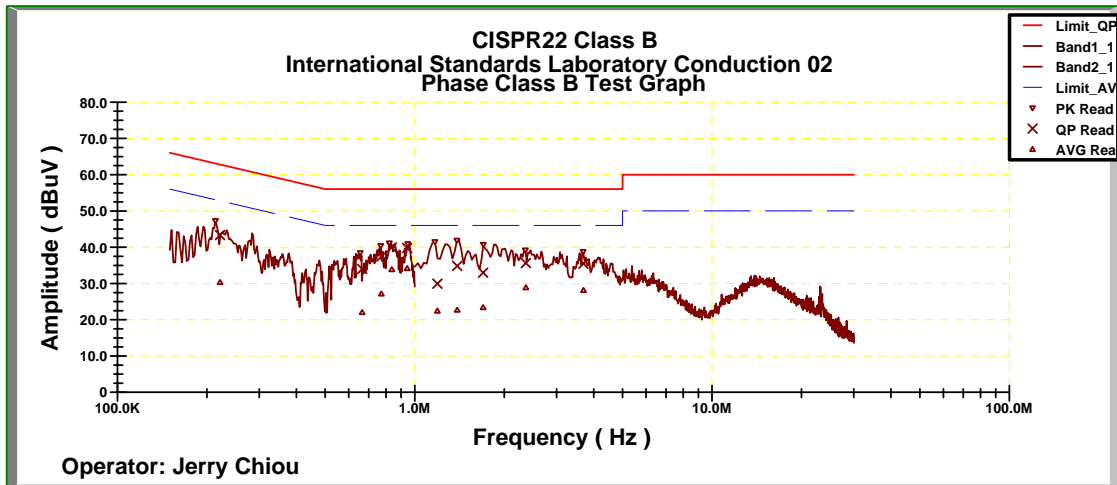

Power Line Conducted Emissions (Neutral) Channel 1, 6, 11

Operator: Jerry Chiou

Temperature (C): 25

Humidity (%): 56

Frequency	LISN Loss	Cable Loss	QP Corrct.	QP Limit	QP Margin	AVE Corrct.	AVE Limit	AVE Margin
MHz	(dB)	(dB)	Amp.(dBuV)	(dBuV)	(dB)	Amp.(dBuV)	(dBuV)	(dB)
0.30908	0.40	0.10	43.57	61.45	-17.89	31.07	51.45	-20.38
0.51928	0.40	0.07	36.82	56.00	-19.18	23.19	46.00	-22.81
0.76323	0.40	0.07	38.15	56.00	-17.85	30.89	46.00	-15.11
0.8621	0.40	0.07	39.08	56.00	-16.92	31.88	46.00	-14.12
0.94666	0.40	0.07	38.90	56.00	-17.10	31.68	46.00	-14.32
1.35899	0.50	0.08	35.24	56.00	-20.76	26.31	46.00	-19.69
1.57889	0.50	0.08	35.67	56.00	-20.33	24.01	46.00	-21.99
1.88815	0.50	0.09	38.04	56.00	-17.96	23.48	46.00	-22.52
2.00689	0.50	0.09	37.75	56.00	-18.25	28.39	46.00	-17.61
2.47822	0.50	0.10	34.18	56.00	-21.82	25.28	46.00	-20.72

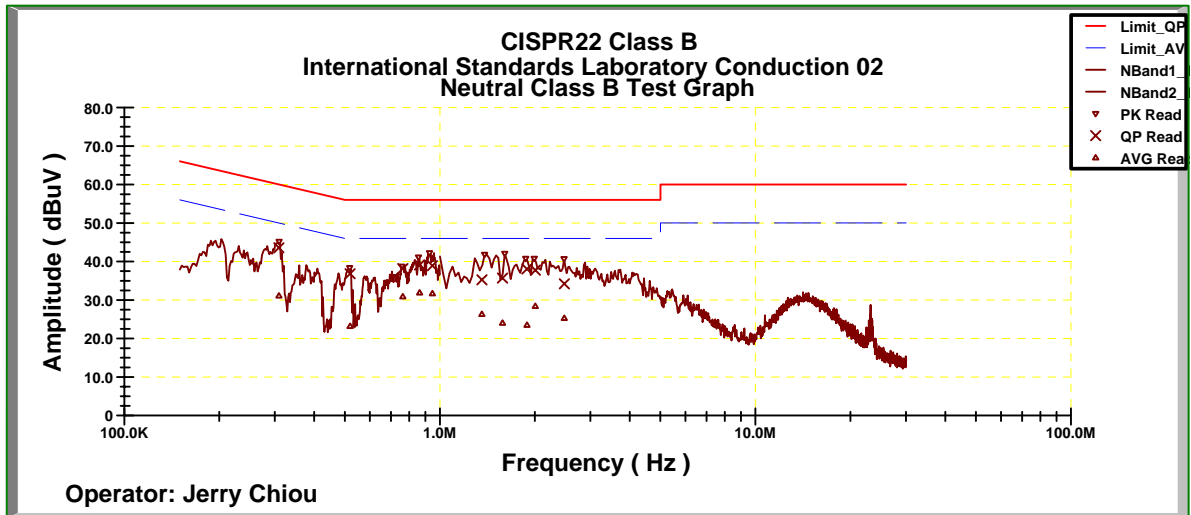

* NOTE: During the test, the EMI receiver was set to Max. Hold then switch the EUT Channel between 1, 6, 11 to get the maximum reading of all these channels.
Margin = Amplitude + Insertion Loss - Limit
A margin of -8dB means that the emission is 8dB below the limit

4.2 Bandwidth for DSSS [Section 15.247 (a)(2)]

4.2.1 Test Procedure

The Transmitter output of EUT was connected to the spectrum analyzer. The 6 dB bandwidth of the fundamental frequency was measured. The setting of spectrum analyzer is as follows

Equipment mode	Spectrum analyzer
Detector function	Peak mode
RBW	100KHz
VBW	100KHz

4.2.2 Test Setup

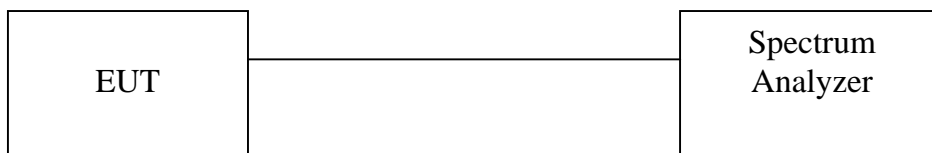

4.2.3 Test Data:

6dB Bandwidth

Temp. (deg. C): 25

Humidity (%): 50

Test Engr: Jerry Chiou

Chennel	Frequency (MHz)	6dB Bandwidth (MHz)	Limit (MHz)	Pass/Fail
1	2412	12.12	0.5	Pass
6	2437	12.12	0.5	Pass
11	2462	12.12	0.5	Pass

Channel 1:

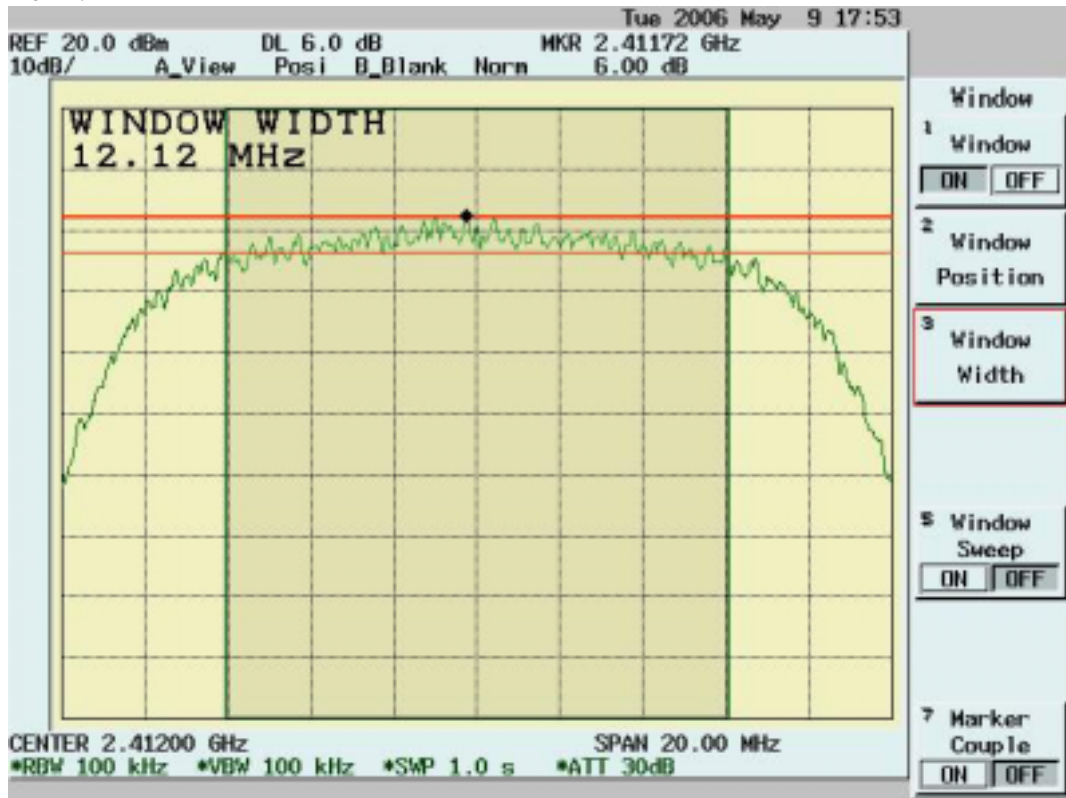

Channel 6:

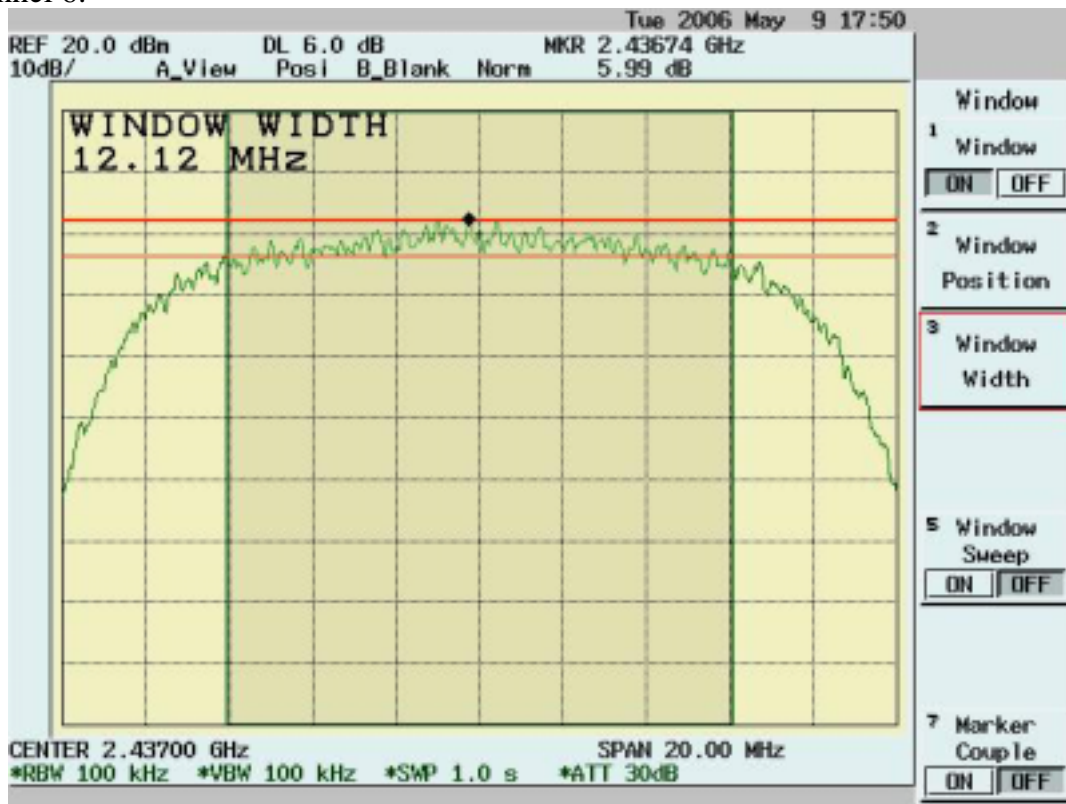

Channel 11:



4.3 DSSS Maximum Peak Output Power [Section 15.247 (b)(1)]

4.3.1 Test Procedure

The Transmitter output of EUT was connected to the peak power analyzer.

4.3.2 Test Setup

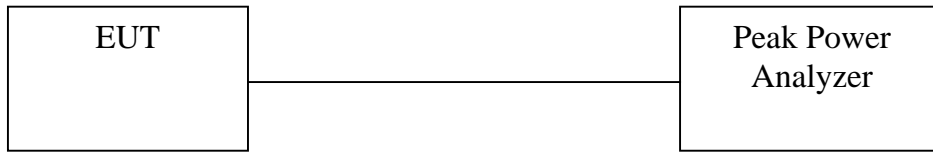

4.3.3 Test Data

Maximum Peak Output Power

Temp. (deg. C): 25
 Humidity (%): 50
 Test Engr: Jerry Chiou

Channel	Frequency (Mhz)	Analyzer Reading (dBm)	Cable Loss (dB)	Peak Power Output (mW)	Peak Power Output (dBm)	Limit (dBm)	Pass/Fail
1	2412	15.249	1.1	43.14	16.349	30	Pass
6	2437	15.156	1.1	42.23	16.256	30	Pass
11	2462	14.937	1.1	40.15	16.037	30	Pass

4.4 Radiated Emission Measurement [Section [15.247(c)(4)]

4.4.1 EUT Configuration

The equipment under test was set up on the 10 meter chamber with measurement distance of 3 meters. The EUT was placed on a non-conductive table 80cm above ground.

Any changes made to the configuration, or modifications made to the EUT, during testing are noted in the following test record.

4.4.2 Test Procedure

The system was set up as described above, with the EMI diagnostic software running. We found the maximum readings by varying the height of antenna and then rotating the turntable. Both polarization of antenna, horizontal and vertical, are measured.

30M to 1GHz: The highest emissions between 30 MHz to 1000 MHz were also analyzed in details by operating the spectrum analyzer and/or EMI receiver in quasi-peak mode to determine the precise amplitude of the emissions. While doing so, the interconnecting cables and major parts of the system were moved around, the antenna height was varied between one and four meters, its polarization was varied between vertical and horizontal, and the turntable was slowly rotated, to maximize the emission.

1GHz – 25GHz: The highest emissions were also analyzed in details by operating the spectrum analyzer and/or EMI receiver in peak mode to determine the precise amplitude of the emission. While doing so, the interconnecting cables and major parts of the system were moved around, the antenna height was varied between one and four meters, its polarization was varied between vertical and horizontal, and the turntable was slowly rotated, to maximize the emission. During test the EMI receiver and spectrum was setup according to *EMI Receiver/Spectrum Analyzer Configuration*.

For the test of 2nd to 10th harmonics frequencies, the equipment setup was also refer to *EMI Receiver/Spectrum Analyzer Configuration*. The frequencies were tested using Peak mode first, if the test data is higher than the emissions limit, an additional measurement using Average mode will be performed and the average reading will be compared to the limit and record in test report.

4.4.3 EMI Receiver/Spectrum Analyzer Configuration (for the frequencies tested)

Frequency Range Tested:	30MHz~1000MHz
Detector Function:	Quasi-Peak Mode
Resolution Bandwidth (RBW):	120KHz
Video Bandwidth (VBW)	1MHz
Frequency Range Tested:	1GHz – 25 GHz
Detector Function:	Peak Mode
Resolution Bandwidth (RBW):	1MHz
Video Bandwidth (VBW)	3MHz
Frequency Range Tested:	1GHz – 25 GHz
Detector Function:	Average Mode
Resolution Bandwidth (RBW):	1MHz
Video Bandwidth (VBW)	10 Hz

4.4.4 Test Data (30MHz – 1GHz):

30M – 1GHz Open Field Radiated Emissions (Horizontal) Channel 1, 6, 11

Operator: Jerry Chiou
 Temperature (C): 23
 Humidity (%): 59

Frequency	Rx Amp.	Ant Fact	CableLoss	PreAmpGain	Corrct. Emi.	Limit	Margin	Ant. Pos.	Table Pos.
MHz	(dBuV)	(dB/m)	(dB)	(dB)	(dBuV/m)	(dBuV/m)	(dB)	(cm)	(deg)
44.55	22.05	9.92	1.29	0.00	33.27	40.00	-6.73	102.00	298.00
47.46	15.06	8.62	1.36	0.00	25.04	40.00	-14.96	102.00	200.00
165.8	17.37	8.64	2.67	0.00	28.68	43.50	-14.82	102.00	118.00
450.01	9.81	16.20	5.21	0.00	31.22	46.00	-14.78	102.00	20.00
793.39	2.02	20.11	7.98	0.00	30.12	46.00	-15.88	102.00	20.00
799.21	2.28	20.10	8.04	0.00	30.42	46.00	-15.58	196.00	7.00
817.64	2.34	20.28	8.25	0.00	30.87	46.00	-15.13	196.00	7.00
833.16	5.46	20.43	8.35	0.00	34.24	46.00	-11.76	102.00	167.00

30M – 1GHz Open Field Radiated Emissions (Vertical) Channel 1, 6, 11

Operator: Jerry Chiou
 Temperature (C): 23
 Humidity (%): 59

Frequency	Rx Amp.	Ant Fact	CableLoss	PreAmpGain	Corrct. Emi.	Limit	Margin	Ant. Pos.	Table Pos.
MHz	(dBuV)	(dB/m)	(dB)	(dB)	(dBuV/m)	(dBuV/m)	(dB)	(cm)	(deg)
41.64	8.92	11.38	1.19	0.00	21.49	40.00	-18.51	196.00	23.00
44.55	22.74	9.92	1.29	0.00	33.96	40.00	-6.04	102.00	298.00
47.46	15.19	8.62	1.36	0.00	25.16	40.00	-14.84	102.00	200.00
98.87	13.95	10.07	2.04	0.00	26.07	43.50	-17.43	102.00	249.00
116.33	13.43	11.56	2.18	0.00	27.17	43.50	-16.33	102.00	265.00
450.01	8.06	16.20	5.21	0.00	29.47	46.00	-16.53	102.00	20.00
662.44	2.79	19.00	6.85	0.00	28.64	46.00	-17.36	102.00	118.00
831.22	6.40	20.41	8.34	0.00	35.16	46.00	-10.84	102.00	167.00

NOTE:

- During the Pre-test, the EUT has been tested for Channel 1, 6, 11 transmit from Main and Aux antenna respectively to get all the critical emission frequencies. In the final test all the critical emission frequencies has been tested and the test data are listed above.
- Margin = Corrected Amplitude – Limit
 Corrected Amplitude = Radiated Amplitude + Antenna Correction Factor + Cable Loss - Pre-Amplifier Gain
 A margin of -8dB means that the emission is 8dB below the limit

All frequencies from 30MHz to 1GHz have been tested

4.4.5 Test Data (1GHz – 25 GHz) .

1GHz~ 25 GHz (Horizontal), Channel 1: 2412 MHz

Operator: Jerry Chiou

RBW: 1MHz
 Humidity (%): 39
 Temperature (C): 26

Frequency MHz	Rx_R. dBuV	Ant_F. dB/m	Cab_L. dB	PreAmpl dB	Emission dBuV/m	Limit dBuV/m	Margin dB	A.Tower cm	T.Table deg
1956.54	36.00 pk	30.63	2.57	23.75	45.45 pk	54.00 av	-8.55	100	46
2301.2	37.24 pk	30.94	1.68	24.40	45.46 pk	54.00 av	-8.54	101	138
2358.64	42.37 pk	30.93	1.51	24.52	50.28 pk	54.00 av	-3.72	101	156
8511.99	29.82 pk	41.09	3.80	26.38	48.33 pk	54.00 av	-5.67	102	135

1GHz~ 25 GHz (Vertical), Channel 1: 2412 MHz

Operator: Jerry Chiou

RBW: 1MHz
 Humidity (%): 39
 Temperature (C): 22

Frequency MHz	Rx_R. dBuV	Ant_F. dB/m	Cab_L. dB	PreAmpl dB	Emission dBuV/m	Limit dBuV/m	Margin dB	A.Tower cm	T.Table deg
1844.16	35.59 pk	29.69	2.48	23.75	44.01 pk	54.00 av	-9.99	100	54
1894.11	35.51 pk	30.11	2.52	23.75	44.39 pk	54.00 av	-9.61	100	50
2066.43	35.48 pk	30.99	2.40	23.89	44.97 pk	54.00 av	-9.03	100	64

Note:

- According to the standards used, Where limits are specified by agencies for both average and peak (or quasi-peak) detection , if the peak (or quasi-peak) measured value complies with the average limit , it is unnecessary to perform an average measurement.
- “ * ”: Fundamental Frequency
- “***”: Not in the restricted band, Limit level=Fundamental Emission-20dB
- “ pk ”: peak mode
- “ av ”: average mode
- “ --- ”: No meter reading data due to the emission level is smaller than spectrum noise level.
- The Spectrum noise level+Correction Factor < Limit - 6 dB
- Margin=Corrected Amplitude – Limit
- Corrected Amplitude=Radiated Amplitude+Antenna Correction Factor+Cable Loss-Pre-Amplifier Gain
- A margin of -8dB means that the emission is 8dB below the limit.

All frequencies from 1GHz to 25 GHz have been tested.

1GHz~ 25 GHz (Horizontal) , Channel 6 : 2437 MHz

Operator: Jerry Chiou

RBW: 1MHz
Humidity (%): 39
Temperature (C): 26

Frequency	Rx_R.	Ant_F.	Cab_L.	PreAmpl	Emission	Limit	Margin	A.Tower	T.Table
MHz	dBuV	dB/m	dB	dB	dBuV/m	dBuV/m	dB	cm	deg
2358.64	38.25 pk	30.93	1.51	24.52	46.16 pk	54.00 av	-7.84	101	156
2386.11	44.44 pk	30.92	1.42	24.58	52.20 pk	54.00 av	-1.80	101	164

1GHz~ 25 GHz (Vertical), Channel 6 : 2437 MHz

Operator: Jerry Chiou

RBW: 1MHz
Humidity (%): 39
Temperature (C): 26

Frequency	Rx_R.	Ant_F.	Cab_L.	PreAmpl	Emission	Limit	Margin	A.Tower	T.Table
MHz	dBuV	dB/m	dB	dB	dBuV/m	dBuV/m	dB	cm	deg
1944.06	35.36 pk	30.53	2.56	23.75	44.70 pk	54.00 av	-9.30	100	47
2058.94	35.82 pk	30.99	2.42	23.88	45.35 pk	54.00 av	-8.65	100	62
2066.43	35.59 pk	30.99	2.40	23.89	45.08 pk	54.00 av	-8.92	100	64

Note:

- According to the standards used, Where limits are specified by agencies for both average and peak (or quasi-peak) detection , if the peak (or quasi-peak) measured value complies with the average limit , it is unnecessary to perform an average measurement.
- “ * ”: Fundamental Frequency
- “***”: Not in the restricted band, Limit level=Fundamental Emission-20dB
- “ pk ”: peak mode
- “ av ”: average mode
- “ --- ”: No meter reading data due to the emission level is smaller than spectrum noise level.
- The Spectrum noise level+Correction Factor < Limit - 6 dB
- Margin=Corrected Amplitude – Limit
- Corrected Amplitude=Radiated Amplitude+Antenna Correction Factor+Cable Loss-Pre-Amplifier Gain
- A margin of -8dB means that the emission is 8dB below the limit.

All frequencies from 1GHz to 25 GHz have been tested.

1GHz~ 25 GHz (Horizontal), Channel 11: 2462 MHz

Operator: Jerry Chiou

RBW: 1MHz
Humidity (%): 39
Temperature (C): 26

Frequency	Rx_R.	Ant_F.	Cab_L.	PreAmpl	Emission	Limit	Margin	A.Tower	T.Table
MHz	dBuV	dB/m	dB	dB	dBuV/m	dBuV/m	dB	cm	deg
2008.99	34.99 pk	31.00	2.57	23.77	44.79 pk	54.00 av	-9.21	100	46
2313.69	37.16 pk	30.94	1.64	24.43	45.31 pk	54.00 av	-8.69	101	141
2368.63	38.55 pk	30.93	1.48	24.55	46.40 pk	54.00 av	-7.60	101	159

1GHz~ 25 GHz (Vertical), Channel 11 : 2462 MHz

Operator: Jerry Chiou

RBW: 1MHz
Humidity (%): 39
Temperature (C): 26

Frequency	Rx_R.	Ant_F.	Cab_L.	PreAmpl	Emission	Limit	Margin	A.Tower	T.Table
MHz	dBuV	dB/m	dB	dB	dBuV/m	dBuV/m	dB	cm	deg
2001.5	34.58 pk	31.00	2.60	23.75	44.42 pk	54.00 av	-9.58	100	43
2111.39	35.00 pk	30.98	2.26	23.99	44.25 pk	54.00 av	-9.75	100	78
2276.22	36.17 pk	30.94	1.76	24.35	44.53 pk	54.00 av	-9.47	101	130
2296.2	36.85 pk	30.94	1.70	24.39	45.10 pk	54.00 av	-8.90	101	136

Note:

- According to the standards used, Where limits are specified by agencies for both average and peak (or quasi-peak) detection , if the peak (or quasi-peak) measured value complies with the average limit , it is unnecessary to perform an average measurement.
- “ * ”: Fundamental Frequency
- “***”: Not in the restricted band, Limit level=Fundamental Emission-20dB
- “ pk” : peak mode
- “ av” : average mode
- “---“: No meter reading data due to the emission level is smaller than spectrum noise level.
- The Spectrum noise level+Correction Factor < Limit - 6 dB
- Margin=Corrected Amplitude – Limit
- Corrected Amplitude=Radiated Amplitude+Antenna Correction Factor+Cable Loss-Pre-Amplifier Gain
- A margin of -8dB means that the emission is 8dB below the limit.

All frequencies from 1GHz to 25 GHz have been tested.

4.5 Band Edge Measurement

4.5.1 Test Procedure (Conducted)

1. The transmitter output of EUT was connected to the spectrum analyzer.
 Equipment mode: Spectrum analyzer
 Detector function: Peak mode
 SPAN: 100MHz
 RBW: 100KHz
 VBW: 100KHz
 Center frequency: 2.4GHz, 2.4835GHz.
2. Using Peak Search to read the peak power of Carrier frequencies after Maximum Hold function is completed
3. Find the next peak frequency outside the operation frequency band

4.5.2 Test Setup (Conducted)

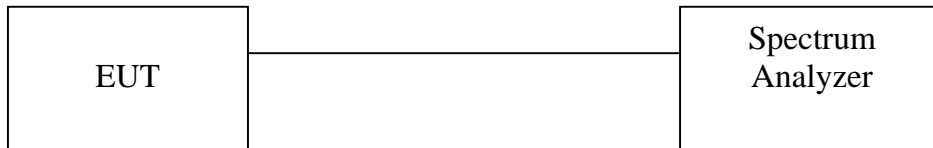

4.5.3 Test Data:

Table: Band Edge measurement (Conducted)

Temp. (deg. C): 25
 Humidity (%): 50
 Test Engr: Jerry Chiou

Channel	Frequency	Spectrum Reading	Carrier - Outsideband Limit: >20dB	Pass/Fail
	(MHz)		(dB)	
1	2411.7	109.49	---	---
Outside band	2396	66.88	42.61	Pass
11	2461.7	109.34	---	---
Outside band	2490.4	54.92	54.42	Pass

Band Edge Conducted measurement

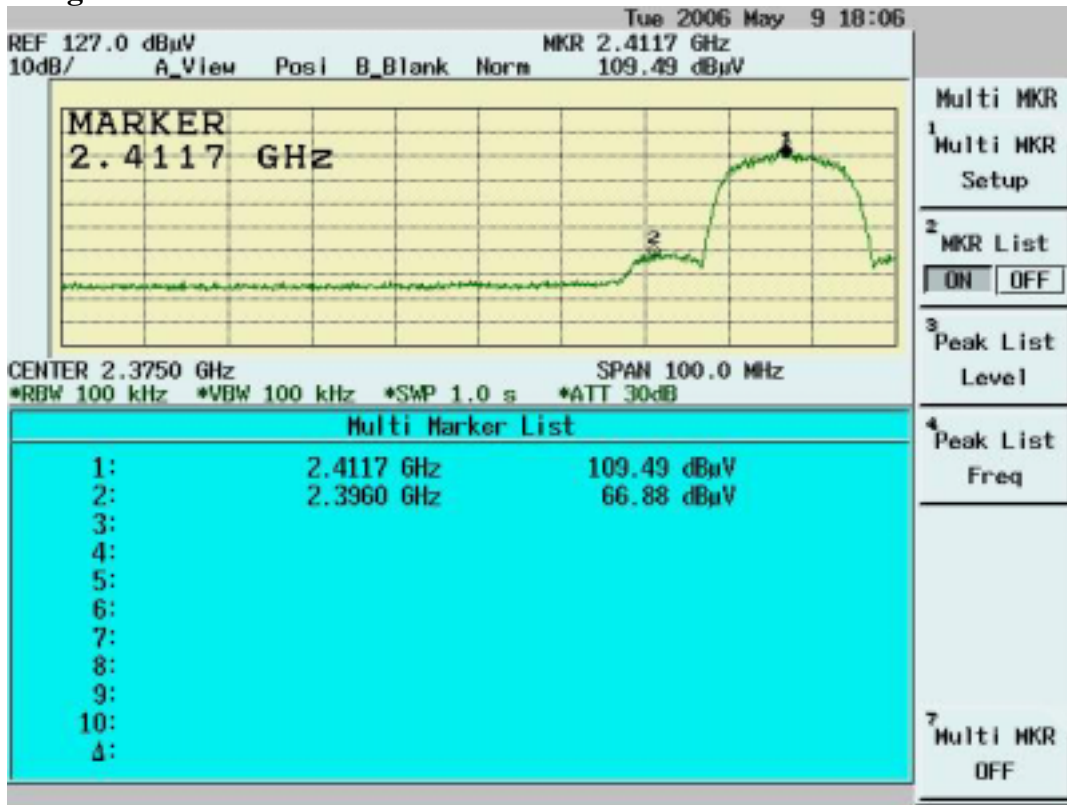

Band Edge Conducted Measurement

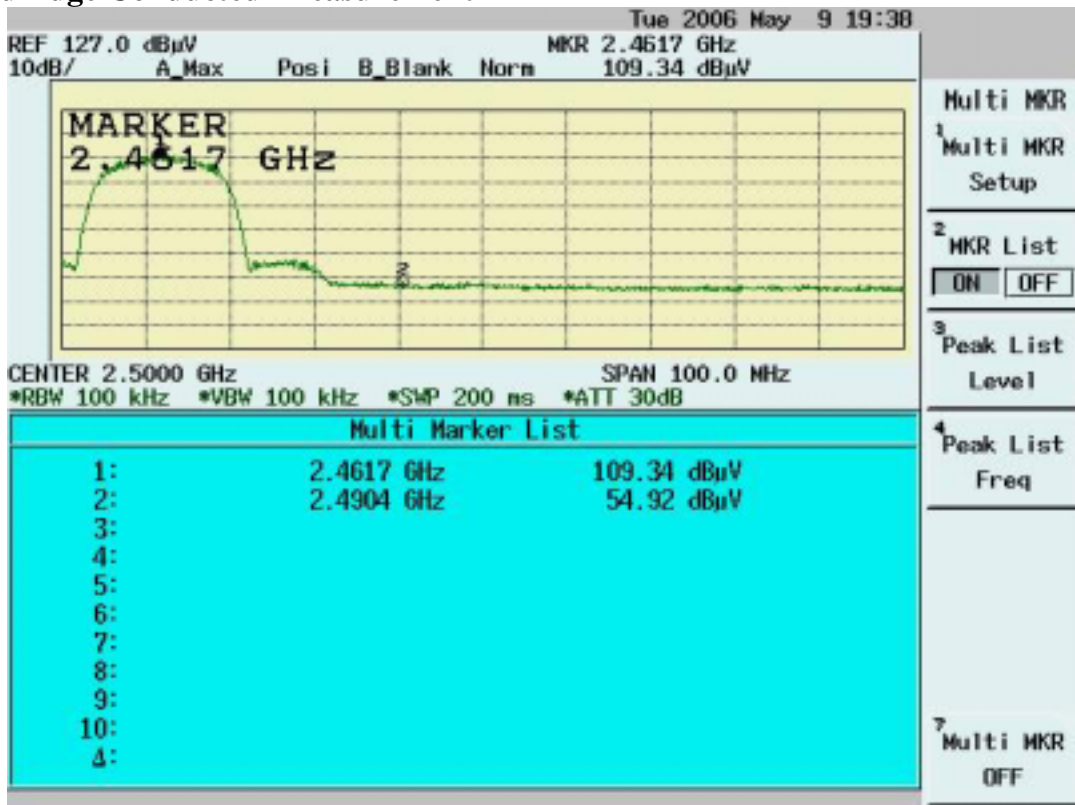

4.5.4 Test Procedure (Radiated)

1. Antenna and Turntable test procedure same as Radiated Emission Measurement.
Equipment mode: Spectrum analyzer
Detector function: Peak mode
SPAN: 100MHz
RBW: 1MHz
VBW: 3MHz
Center frequency: 2.395GHz, 2.48GHz.
2. Using Peak Search to read the peak power of Carrier frequencies after Maximum Hold function is completed.
3. Find the next peak frequency outside the operation frequency band
4. For peak frequency emission level measurement in Restricted Band
Change RBW: 1MHz
VBW: 10Hz
Span: 100MHz.
5. Get the spectrum reading after Maximum Hold function is completed.

4.5.5 Test Setup (Radiated)

Same as *Radiated Emission Measurement*

4.5.6 Test Data

Table Band Edge measurement (Radiated)

Temp. (deg. C): 25

Test Engr: Jerry Chiou Humidity (%): 50

Description	Frequency	Spectrum	Correction	Emission	dBc (Limit:	Limit	Equip.	Pass
	(MHz)	Reading	Factor	Level	> 20dBc)	(dBuV/m)	Setup	or
		(dBuV)	(dB/m)	(dBuV/m)			VBW	Fail
Channel_1 (average mode)	2413.3	63.09	35.48	98.57	---	---	10Hz	---
Channel_1 (peak mode)	2413.2	72	35.48	107.48	---	---	3MHz	---
Outside band (peak mode)	2396.9	29.36	35.48	64.84	42.64	---	3MHz	Pass
Channel_11 (average mode)	2461.4	64.79	35.5	100.29	---	---	10Hz	---
Channel_11 (peak mode)	2463.2	73.04	35.5	108.54	---	---	3MHz	---
Outside band (peak mode)	2492.3	20.05	35.51	55.56	52.98	---	3MHz	Pass
Channel_1 Restricted band (peak mode)	2374.4	20.52	35.47	55.99	---	74	3MHz	Pass
Restricted band (average mode)	2390	7.96	35.47	43.43	---	54	10Hz	Pass
Channel_11 Restricted band (peak mode)	2492.3	20.05	35.51	55.56	---	74	3MHz	Pass
Restricted band (average mode)	2499.3	8	35.51	43.51	---	54	10Hz	Pass

Note:

- The Spectrum plot of emission level measurement in Restricted band is attached.
- Emission Level=Spectrum Reading+Correction Factor
- Correction Factor=Antenna Factor+cable loss–amplifier gain
- Both Horizontal and Vertical polarizaion have been tested and the worst data is listed above.

Band Edge measurement for radiated emission in Restricted Band(Radiated) Peak Mode (Channel 1)

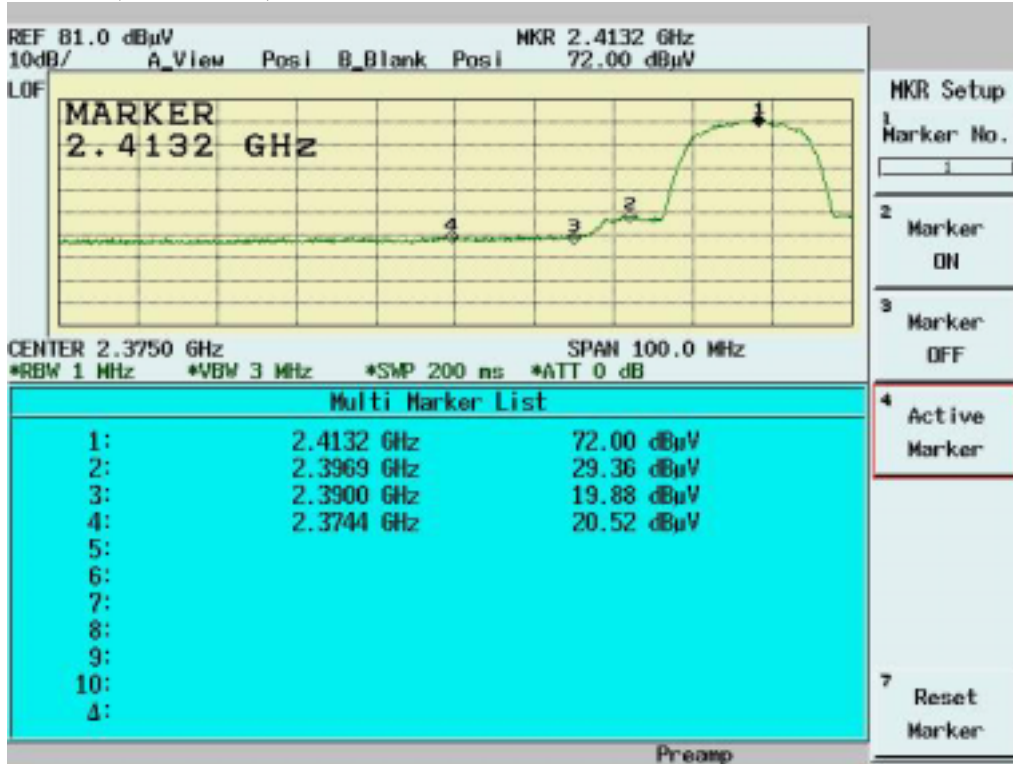

Band Edge measurement for radiated emission in Restricted Band(Radiated) Average Mode (Channel 1)

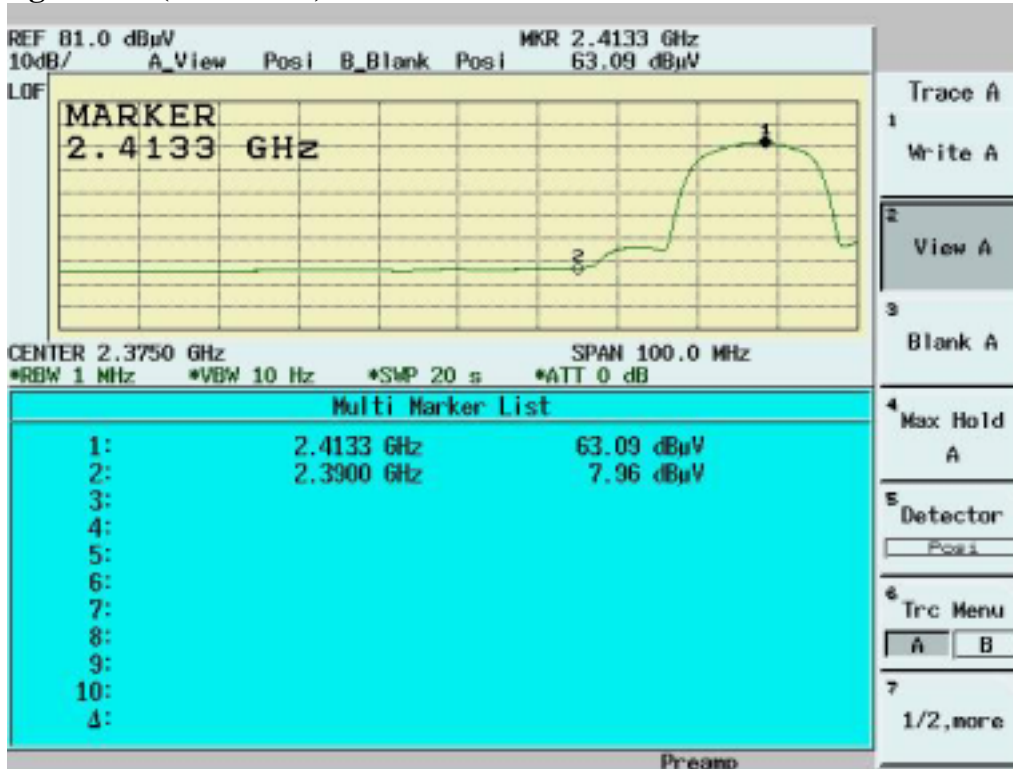

Band Edge measurement for radiated emission in Restricted Band(Radiated) Peak Mode (Channel 11)

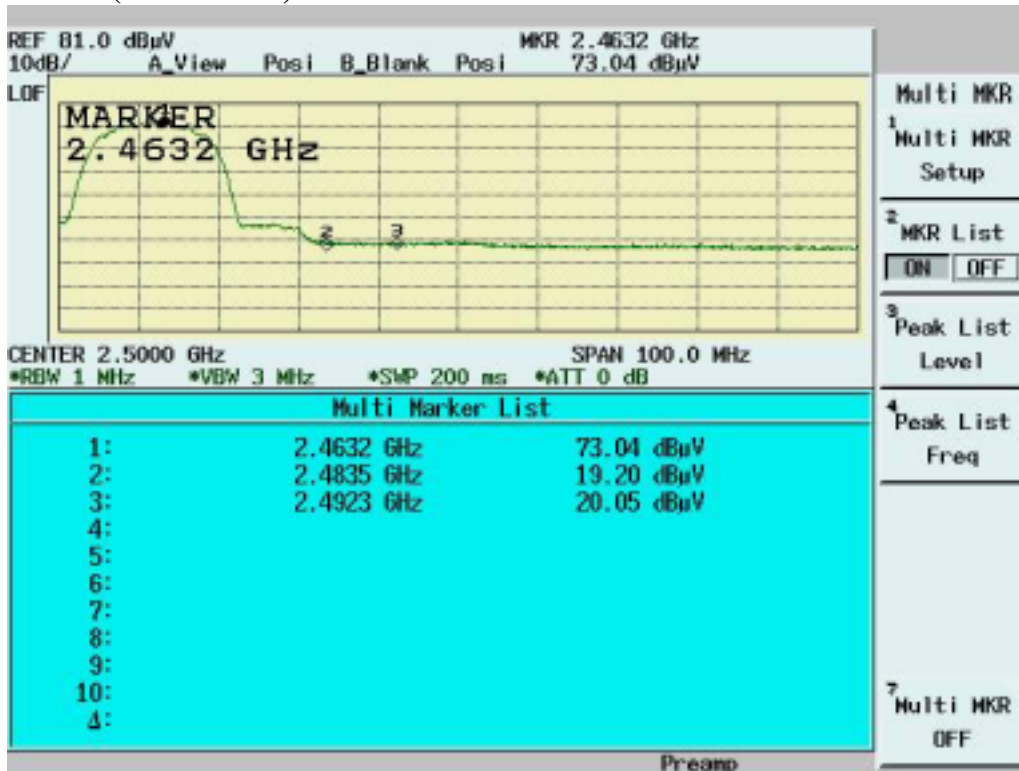

Band Edge measurement for radiated emission in Restricted Band(Radiated) Average Mode (Channel 11)

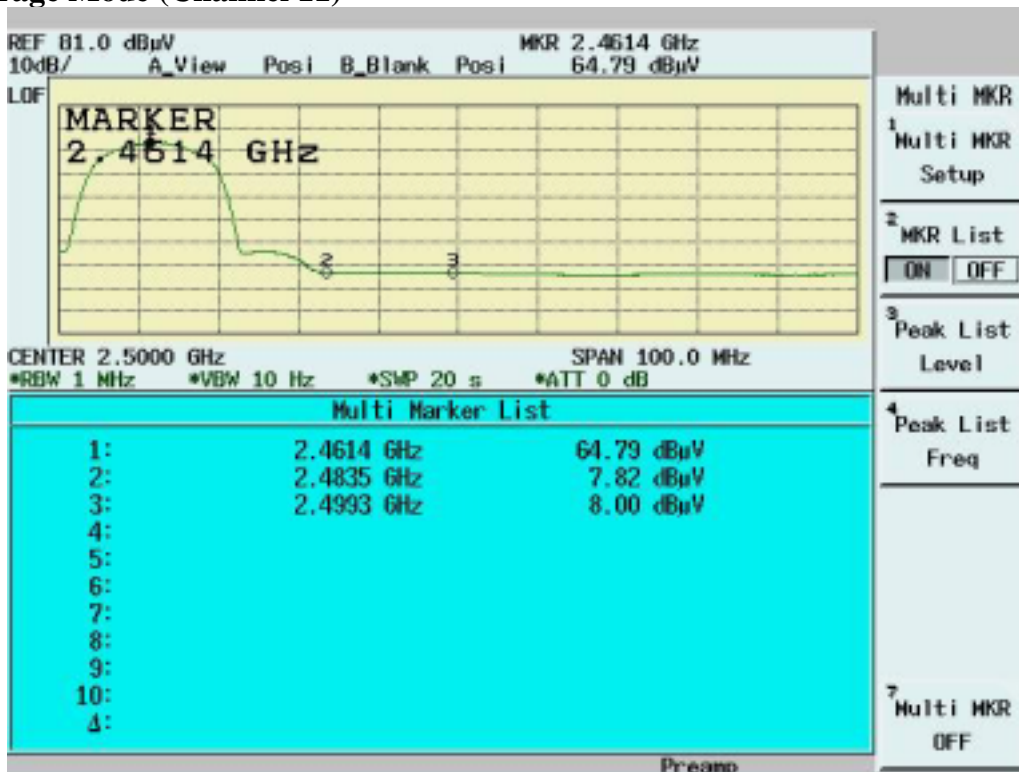



4.6 RF Exposure Measurement [Section 15.247(b)(4) & 1.1307(b)]

See SAR report

4.7 DSSS Peak Power Spectral Density [Section 15.247(d)]

4.7.1 Test Procedure

1. The Transmitter output of EUT was connected to the spectrum analyzer.
 Equipment mode: Spectrum analyzer
 Detector function: Peak mode
 SPAN: 1.5MHz
 RBW: 3KHz
 VBW: 30KHz
 Center frequency: fundamental frequency tested.
 Sweep time= 500 sec.
2. Using Peak Search to read the peak power after Maximum Hold function is completed.

4.7.2 Test Setup



4.7.3 Test Data

Maximum Peak Output Power Density

Temp. (deg. C): 25

Test Engr: Jerry Chiou

Humidity (%): 50

Chennel	Frequency (MHz)	Spectrum Reading (dBm/3KHz)	Cable Loss (dB)	Peak Power Output (dBm/3KHz)	Limit (dBm/3KHz)	Pass/Fail
1	2412	-11.38	1.1	-10.28	8	Pass
6	2437	-11.43	1.1	-10.33	8	Pass
11	2462	-11.57	1.1	-10.47	8	Pass

Channel 1

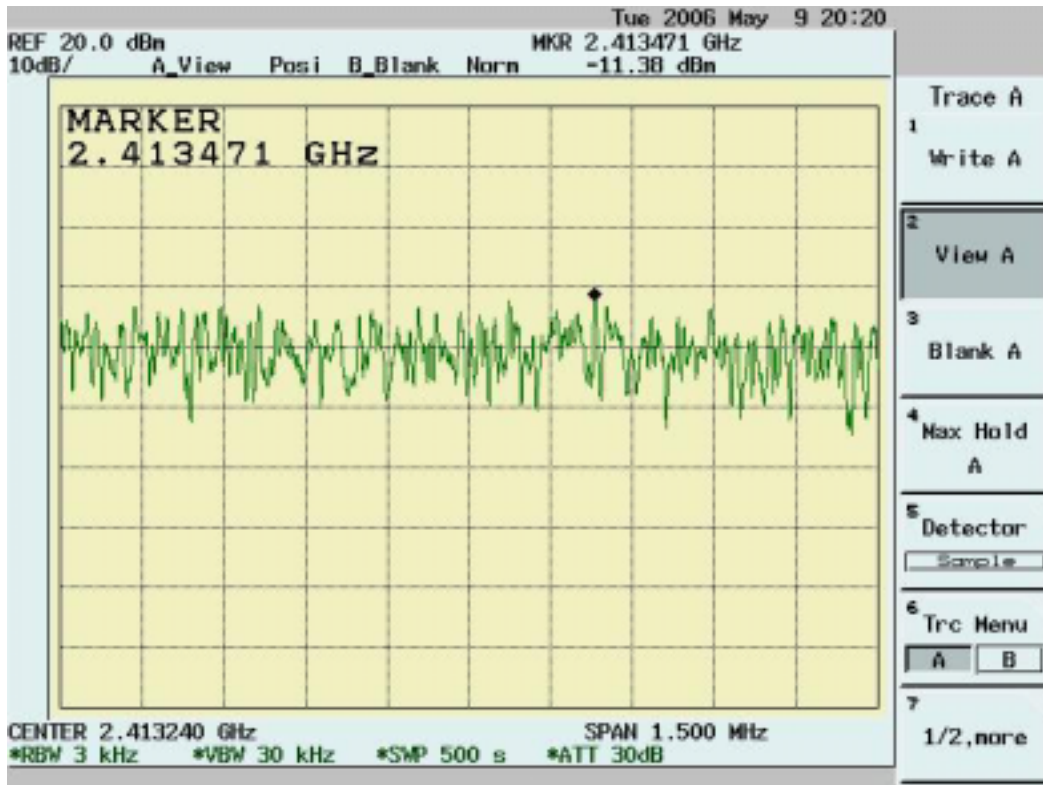

Channel 6

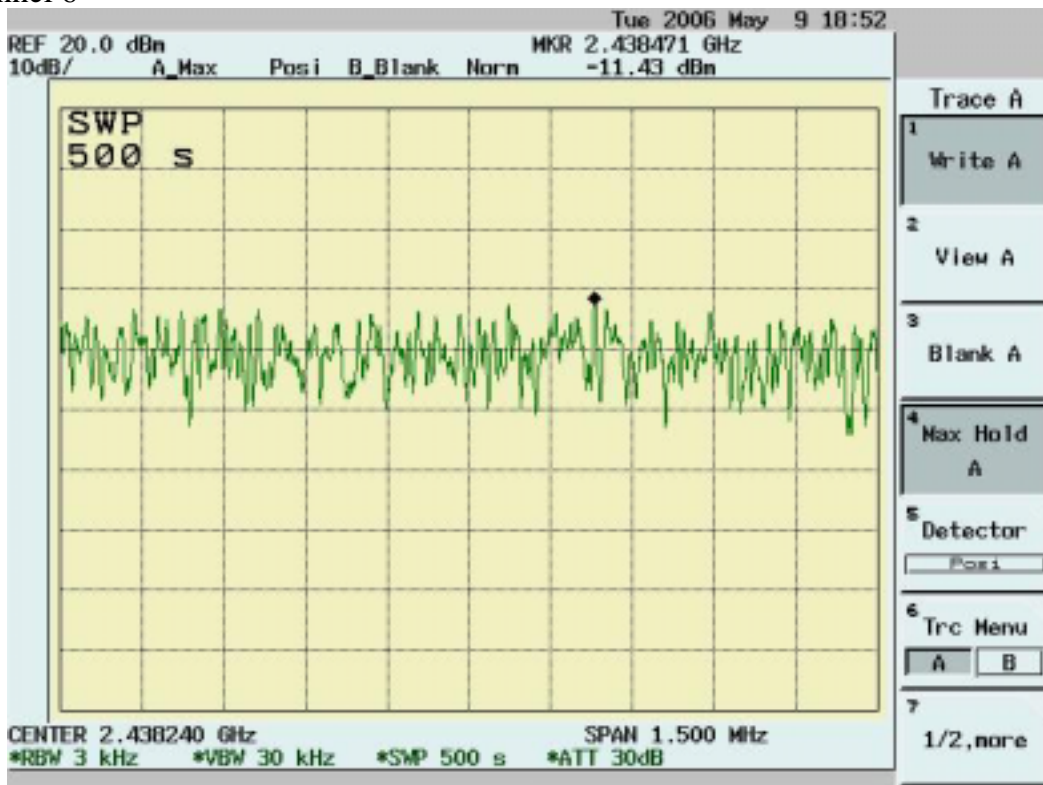

Channel 11

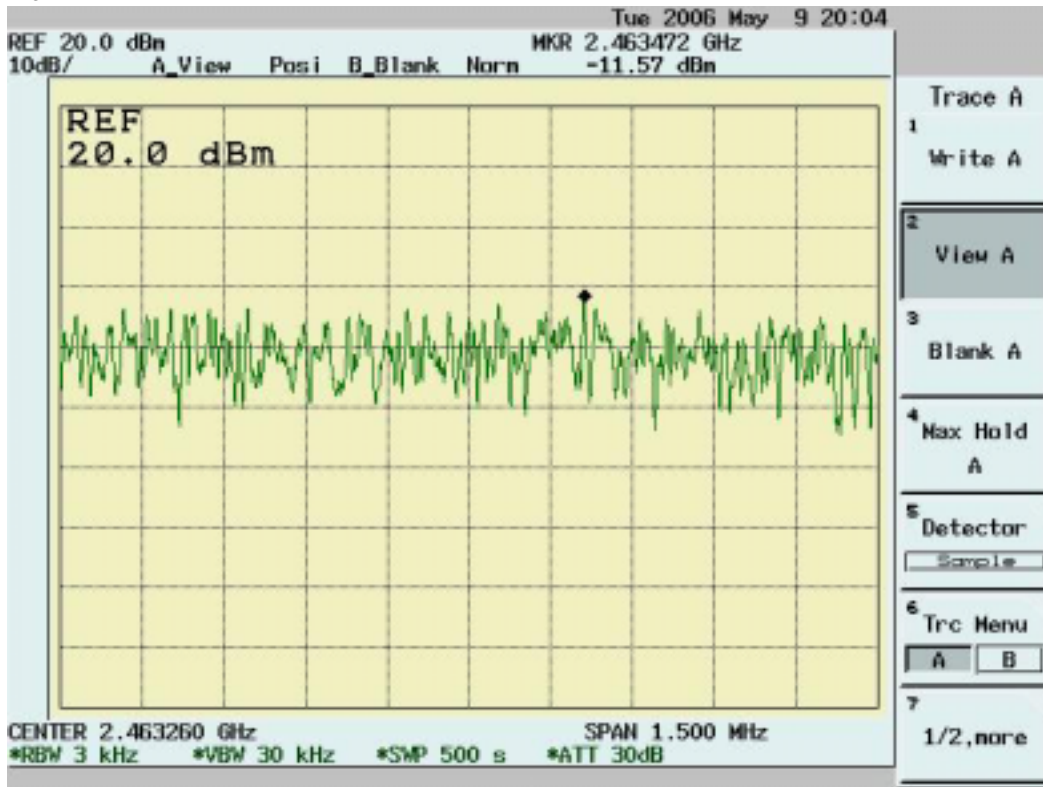

5. TEST RESULTS (802.11g)

5.1 Powerline Conducted Emissions [Section 15.207]

5.1.1 EUT Configuration

The EUT was set up on the non-conductive table that is 1.0 by 1.5 meter, 80cm above ground. The wall of the shielded room was located 40cm to the rear of the EUT.

Power to the EUT was provided through the LISN. The impedance vs. frequency characteristic of the LISN is complied with the limit used.

Both lines (neutral and hot) were connected to the LISN in series at testing. A coaxial-type connector which provides one 50 ohms terminating impedance was provided for connecting the test instrument. The excess length of the power cord was folded back and forth at the center of the lead so as to form a bundle not exceeding 40cm in length.

Any changes made to the configuration, or modifications made to the EUT, during testing are noted in the following test record.

If the EUT is a Personal Computer or a peripheral of personal computer, and the personal computer has an auxiliary AC outlet which can be used for providing power to an external monitor, then all measurements will be made with the monitor power from first the computer-mounted AC outlet and then a floor-mounted AC outlet.

5.1.2 Test Procedure

The system was set up as described above, with the EMI diagnostic software running. The main power line conducted EMI tests were run on the hot and neutral conductors of the power cord and the results were recorded. The effect of varying the position of the interface cables has been investigated to find the configuration that produces maximum emission.

At the frequencies where the peak values of the emissions were higher than 6dB below the applicable limits, the emissions were also measured with the quasi-peak detectors. At the frequencies where the quasi-peak values of the emissions were higher than 6dB below the applicable average limits, the emissions were also measured with the average detectors.

The highest emissions were analyzed in details by operating the spectrum analyzer in fixed tuned mode to determine the nature of the emissions and to provide information which could be useful in reducing their amplitude.

5.1.3 EMI Receiver/Spectrum Analyzer Configuration (for the frequencies tested)

Frequency Range	150 KHz--30MHz
Detector Function	Quasi-Peak/Average
Bandwidth (RBW)	9KHz

5.1.4 Test Data:

Power Line Conducted Emissions (Hot) Channel 1, 6, 11

Operator: Jerry Chiou
 Temperature (C): 25
 Humidity (%): 56

Frequency	LISN Loss	Cable Loss	QP Corrct.	QP Limit	QP Margin	AVE Corrct.	AVE Limit	AVE Margin
MHz	(dB)	(dB)	Amp.(dBuV)	(dBuV)	(dB)	Amp.(dBuV)	(dBuV)	(dB)
0.3326	0.17	0.10	43.14	60.78	-17.64	28.89	50.78	-21.89
0.56808	0.20	0.07	35.67	56.00	-20.33	20.23	46.00	-25.77
0.79261	0.20	0.07	36.29	56.00	-19.71	28.10	46.00	-17.90
0.89058	0.20	0.07	37.93	56.00	-18.07	30.13	46.00	-15.88
0.99456	0.20	0.07	37.73	56.00	-18.27	30.43	46.00	-15.57
1.10604	0.21	0.07	36.95	56.00	-19.05	28.48	46.00	-17.52
1.43386	0.24	0.08	35.27	56.00	-20.73	24.47	46.00	-21.53
3.81864	0.39	0.14	28.84	56.00	-27.16	20.72	46.00	-25.28
4.17876	0.40	0.14	28.12	56.00	-27.88	19.64	46.00	-26.36
14.5944	0.50	0.29	24.48	60.00	-35.52	18.86	50.00	-31.14

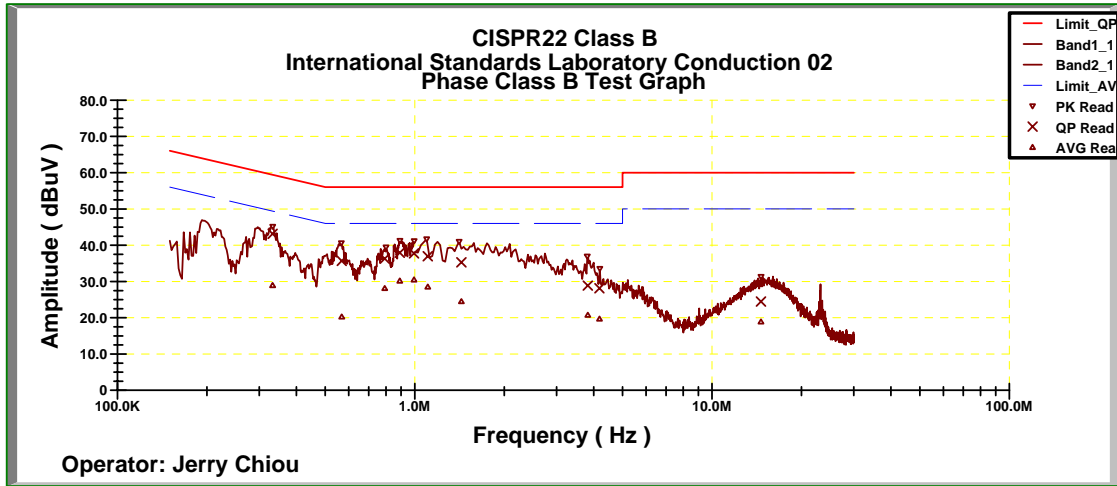

Power Line Conducted Emissions (Neutral) Channel 1, 6, 11

Operator: Jerry Chiou

Temperature (C): 25

Humidity (%): 56

Frequency	LISN Loss	Cable Loss	QP Corrct.	QP Limit	QP Margin	AVE Corrct.	AVE Limit	AVE Margin
MHz	(dB)	(dB)	Amp.(dBuV)	(dBuV)	(dB)	Amp.(dBuV)	(dBuV)	(dB)
0.32371	0.40	0.10	42.81	61.04	-18.23	28.26	51.04	-22.78
0.5488	0.40	0.07	36.16	56.00	-19.84	20.69	46.00	-25.31
0.77253	0.40	0.07	37.39	56.00	-18.61	28.63	46.00	-17.37
0.8834	0.40	0.07	39.54	56.00	-16.46	32.24	46.00	-13.76
0.98291	0.40	0.07	39.21	56.00	-16.79	32.79	46.00	-13.21
1.09306	0.50	0.07	37.90	56.00	-18.10	28.44	46.00	-17.56
1.47297	0.50	0.08	38.91	56.00	-17.09	30.29	46.00	-15.71
1.7448	0.50	0.08	36.13	56.00	-19.87	24.11	46.00	-21.89
2.0027	0.50	0.09	36.04	56.00	-19.96	25.60	46.00	-20.40
2.62448	0.50	0.11	33.86	56.00	-22.14	25.44	46.00	-20.56

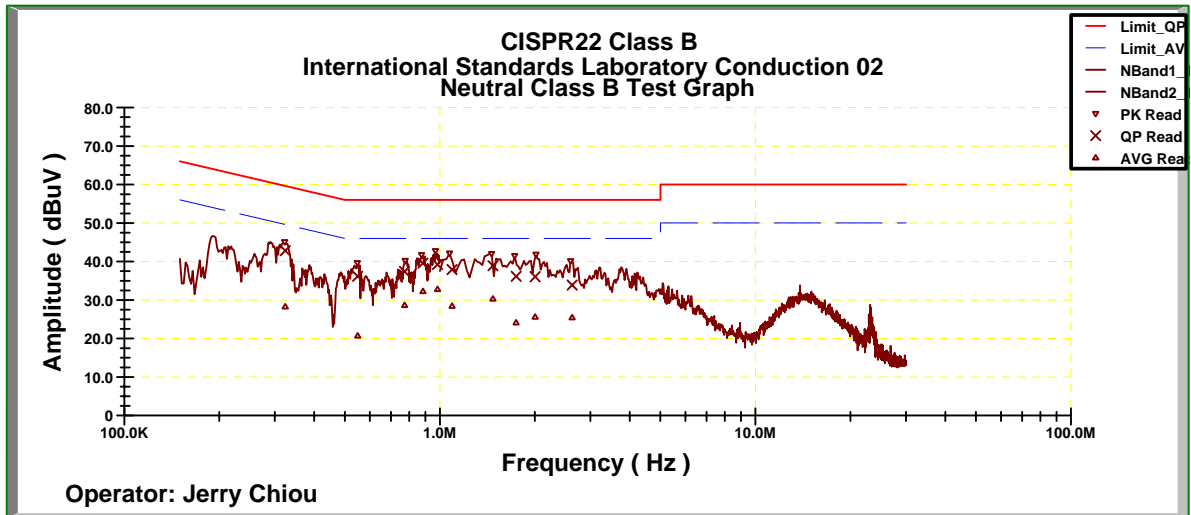

* NOTE: During the test, the EMI receiver was set to Max. Hold then switch the EUT Channel between 1, 6, 11 to get the maximum reading of all these channels.
 Margin = Amplitude + Insertion Loss - Limit
 A margin of -8dB means that the emission is 8dB below the limit

5.2 Bandwidth for DSSS [Section 15.247 (a)(2)]

5.2.1 Test Procedure

The Transmitter output of EUT was connected to the spectrum analyzer. The 6 dB bandwidth of the fundamental frequency was measured. The setting of spectrum analyzer is as follows

Equipment mode	Spectrum analyzer
Detector function	Peak mode
RBW	100KHz
VBW	100KHz

5.2.2 Test Setup



5.2.3 Test Data:

6dB Bandwidth

Temp. (deg. C): 25
 Humidity (%): 50
 Test Engr: Jerry Chiou

Chennel	Frequency (MHz)	6dB Bandwidth (MHz)	Limit (MHz)	Pass/Fail
1	2412	16.44	0.5	Pass
6	2437	16.44	0.5	Pass
11	2462	16.44	0.5	Pass

Channel 1:

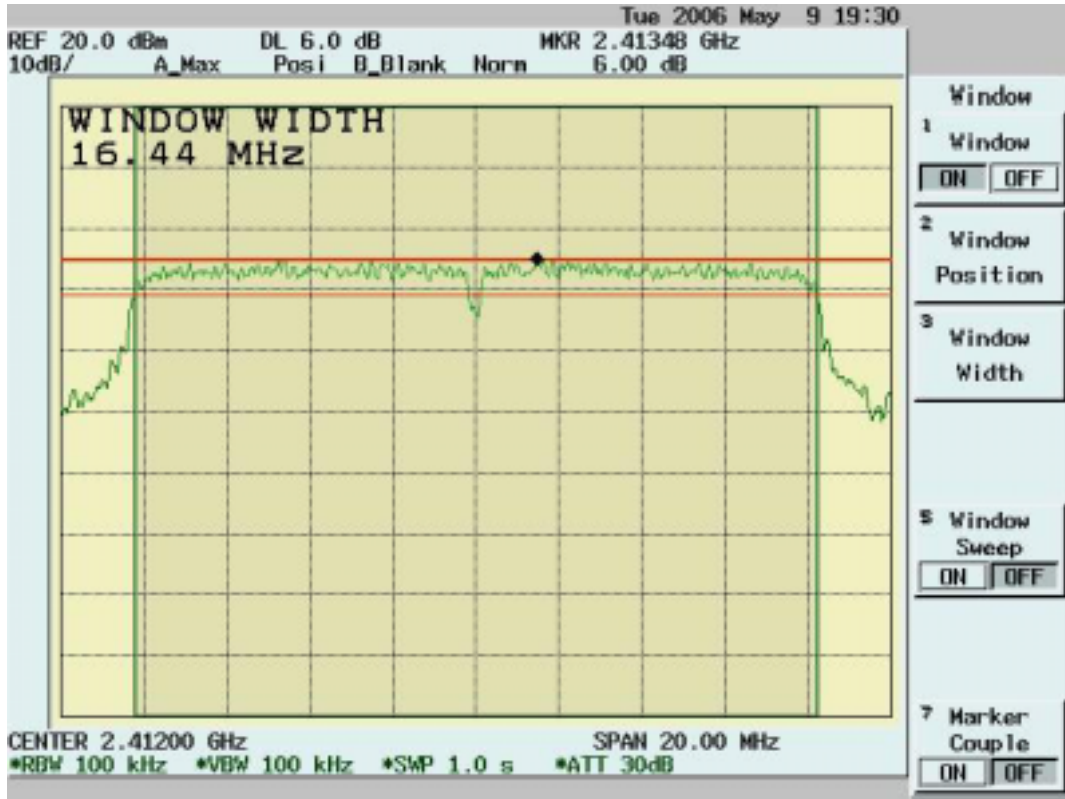

Channel 6:

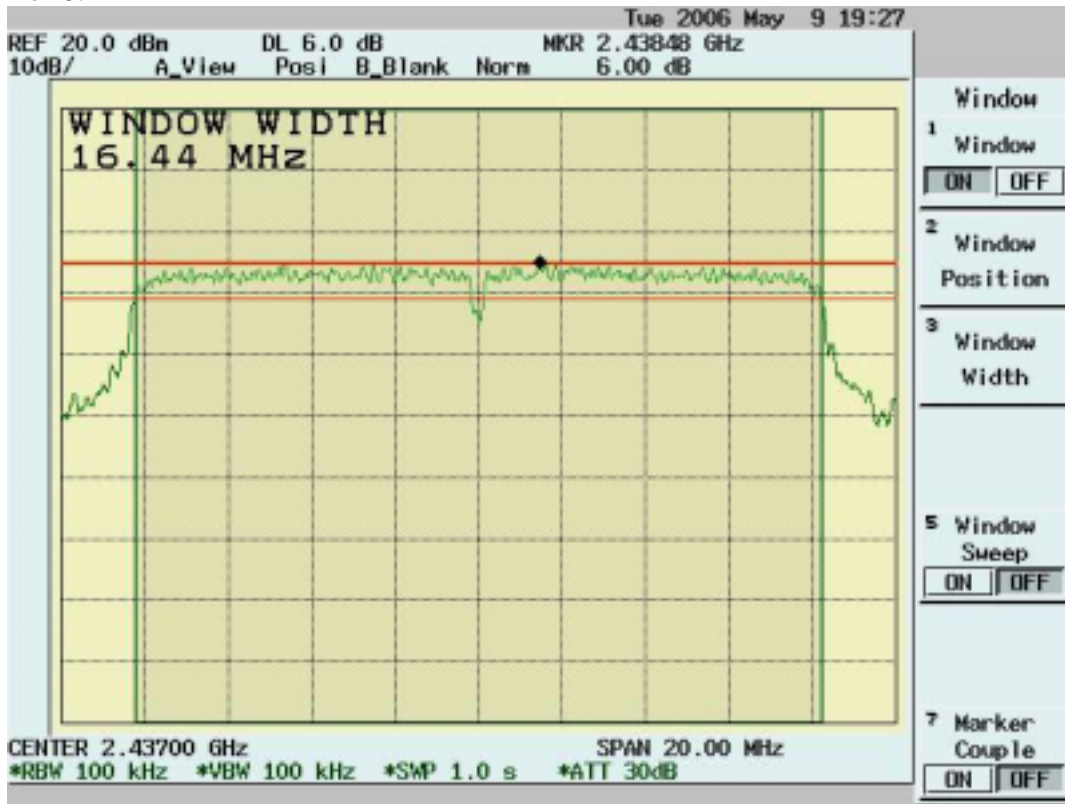

Channel 11:

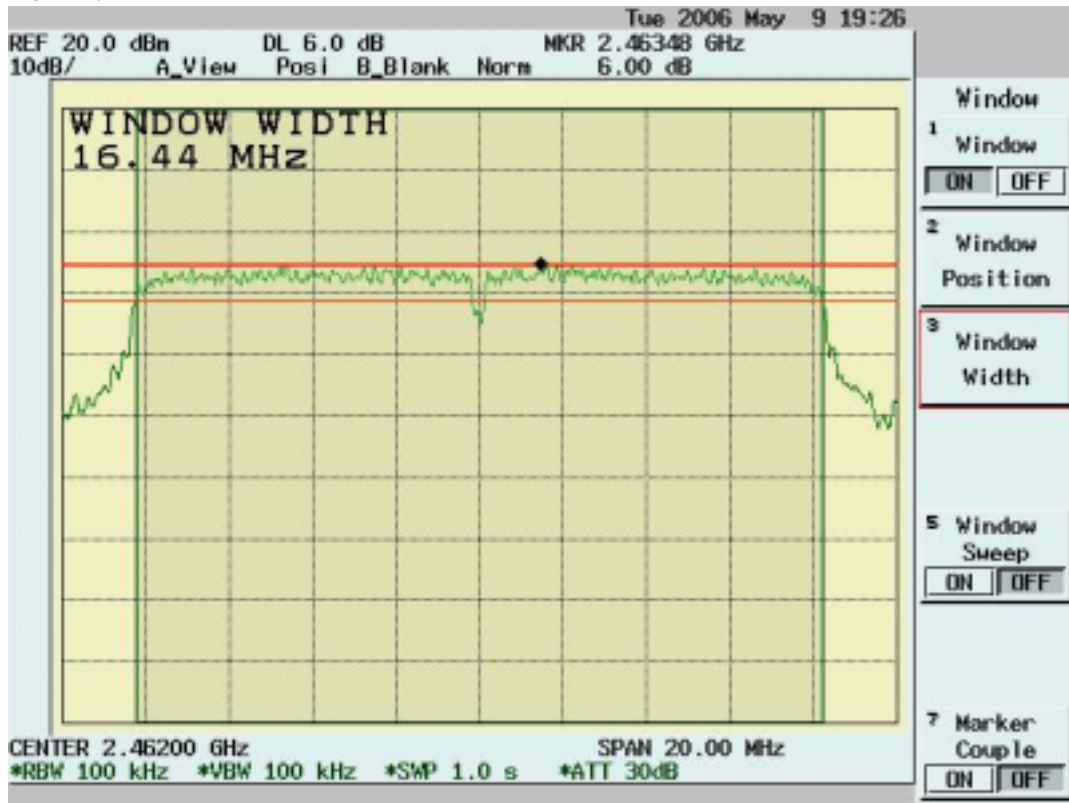

5.3 DSSS Maximum Peak Output Power [Section 15.247 (b)(1)]

5.3.1 Test Procedure

The Transmitter output of EUT was connected to the peak power analyzer.

5.3.2 Test Setup

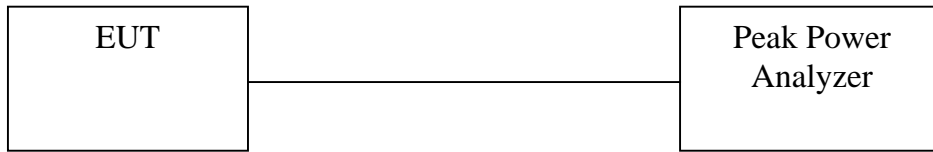

5.3.3 Test Data

Maximum Peak Output Power

Temp. (deg. C): 25
 Humidity (%): 50
 Test Engr: Jerry Chiou

Channel	Frequency (Mhz)	Analyzer Reading (dBm)	Cable Loss (dB)	Peak Power Output (mW)	Peak Power Output (dBm)	Limit (dBm)	Pass/Fail
1	2412	16.062	1.1	52.02	17.162	30	Pass
6	2437	15.843	1.1	49.47	16.943	30	Pass
11	2462	15.812	1.1	49.11	16.912	30	Pass

5.4 Radiated Emission Measurement [Section [15.247(c)(4)]

5.4.1 EUT Configuration

The equipment under test was set up on the 10 meter chamber with measurement distance of 3 meters. The EUT was placed on a non-conductive table 80cm above ground.

Any changes made to the configuration, or modifications made to the EUT, during testing are noted in the following test record.

5.4.2 Test Procedure

The system was set up as described above, with the EMI diagnostic software running. We found the maximum readings by varying the height of antenna and then rotating the turntable. Both polarization of antenna, horizontal and vertical, are measured.

30M to 1GHz: The highest emissions between 30 MHz to 1000 MHz were also analyzed in details by operating the spectrum analyzer and/or EMI receiver in quasi-peak mode to determine the precise amplitude of the emissions. While doing so, the interconnecting cables and major parts of the system were moved around, the antenna height was varied between one and four meters, its polarization was varied between vertical and horizontal, and the turntable was slowly rotated, to maximize the emission.

1GHz – 25GHz: The highest emissions were also analyzed in details by operating the spectrum analyzer and/or EMI receiver in peak mode to determine the precise amplitude of the emission. While doing so, the interconnecting cables and major parts of the system were moved around, the antenna height was varied between one and four meters, its polarization was varied between vertical and horizontal, and the turntable was slowly rotated, to maximize the emission. During test the EMI receiver and spectrum was setup *according to EMI Receiver/Spectrum Analyzer Configuration*.

For the test of 2nd to 10th harmonics frequencies, the equipment setup was also refer to *EMI Receiver/Spectrum Analyzer Configuration*. The frequencies were tested using Peak mode first, if the test data is higher than the emissions limit, an additional measurement using Average mode will be performed and the average reading will be compared to the limit and record in test report.

5.4.3 EMI Receiver/Spectrum Analyzer Configuration (for the frequencies tested)

Frequency Range Tested:	30MHz~1000MHz
Detector Function:	Quasi-Peak Mode
Resolution Bandwidth (RBW):	120KHz
Video Bandwidth (VBW)	1MHz
Frequency Range Tested:	1GHz – 25 GHz
Detector Function:	Peak Mode
Resolution Bandwidth (RBW):	1MHz
Video Bandwidth (VBW)	3MHz
Frequency Range Tested:	1GHz – 25 GHz
Detector Function:	Average Mode
Resolution Bandwidth (RBW):	1MHz
Video Bandwidth (VBW)	10 Hz

5.4.4 Test Data (30MHz – 1GHz):

30M – 1GHz Open Field Radiated Emissions (Horizontal) Channel 1, 6, 11

Operator: Jerry Chiou
 Temperature (C): 23
 Humidity (%): 59

Frequency	Rx Amp.	Ant Fact	CableLoss	PreAmpGain	Corrct. Emi.	Limit	Margin	Ant. Pos.	Table Pos.
MHz	(dBuV)	(dB/m)	(dB)	(dB)	(dBuV/m)	(dBuV/m)	(dB)	(cm)	(deg)
41.64	14.82	11.38	1.19	0.00	27.39	40.00	-12.61	102.00	347.00
44.55	13.34	9.92	1.29	0.00	24.55	40.00	-15.45	102.00	295.00
47.46	22.82	8.62	1.36	0.00	32.80	40.00	-7.20	102.00	143.00
101.78	15.10	10.51	2.05	0.00	27.66	43.50	-15.84	196.00	257.00
450.01	10.43	16.20	5.21	0.00	31.84	46.00	-14.16	102.00	12.00
540.22	5.34	18.37	5.88	0.00	29.58	46.00	-16.42	102.00	44.00
765.26	2.23	20.17	7.74	0.00	30.14	46.00	-15.86	102.00	77.00
829.28	2.77	20.39	8.34	0.00	31.50	46.00	-14.50	102.00	143.00
948.59	1.95	21.28	9.00	0.00	32.23	46.00	-13.77	196.00	290.00

30M – 1GHz Open Field Radiated Emissions (Vertical) Channel 1, 6, 11

Operator: Jerry Chiou
 Temperature (C): 23
 Humidity (%): 59

Frequency	Rx Amp.	Ant Fact	CableLoss	PreAmpGain	Corrct. Emi.	Limit	Margin	Ant. Pos.	Table Pos.
MHz	(dBuV)	(dB/m)	(dB)	(dB)	(dBuV/m)	(dBuV/m)	(dB)	(cm)	(deg)
44.55	12.85	9.92	1.29	0.00	24.07	40.00	-15.93	102.00	295.00
47.46	16.70	8.62	1.36	0.00	26.68	40.00	-13.32	102.00	143.00
98.87	12.77	10.07	2.04	0.00	24.89	43.50	-18.61	102.00	245.00
115.36	13.69	11.55	2.17	0.00	27.41	43.50	-16.09	102.00	227.00
379.2	6.87	16.02	4.59	0.00	27.49	46.00	-18.51	102.00	44.00
450.01	6.72	16.20	5.21	0.00	28.13	46.00	-17.87	102.00	12.00
757.5	2.56	20.19	7.71	0.00	30.46	46.00	-15.54	196.00	11.00
834.13	1.59	20.44	8.35	0.00	30.37	46.00	-15.63	102.00	176.00
923.37	1.82	20.93	8.90	0.00	31.64	46.00	-14.36	102.00	143.00

NOTE:

- During the Pre-test, the EUT has been tested for Channel 1, 6, 11 transmit from Main and Aux antenna respectively to get all the critical emission frequencies. In the final test all the critical emission frequencies has been tested and the test data are listed above.
- Margin = Corrected Amplitude – Limit
 Corrected Amplitude = Radiated Amplitude + Antenna Correction Factor + Cable Loss - Pre-Amplifier Gain
 A margin of -8dB means that the emission is 8dB below the limit

All frequencies from 30MHz to 1GHz have been tested

5.4.5 Test Data (1GHz – 25 GHz) .

1GHz~ 25 GHz (Horizontal), Channel 1: 2412 MHz

Operator: Jerry Chiou

RBW: 1MHz
 Humidity (%): 39
 Temperature (C): 26

Frequency MHz	Rx_R. dBuV	Ant_F. dB/m	Cab_L. dB	PreAmpl dB	Emission dBuV/m	Limit dBuV/m	Margin dB	A.Tower cm	T.Table deg
2028.97	34.84 pk	30.99	2.51	23.81	44.54 pk	54.00 av	-9.46	100	52
2515.98	40.57 pk	30.91	1.36	24.85	47.99 pk	54.00 av	-6.01	102	205
8497.5	29.73 pk	41.10	3.81	26.40	48.24 pk	54.00 av	-5.76	101	138

1GHz~ 25 GHz (Vertical), Channel 1: 2412 MHz

Operator: Jerry Chiou

RBW: 1MHz
 Humidity (%): 39
 Temperature (C): 26

Frequency MHz	Rx_R. dBuV	Ant_F. dB/m	Cab_L. dB	PreAmpl dB	Emission dBuV/m	Limit dBuV/m	Margin dB	A.Tower cm	T.Table deg
1986.51	35.61 pk	30.89	2.59	23.75	45.34 pk	54.00 av	-8.66	100	44
2446.05	36.92 pk	30.91	1.36	24.71	44.48 pk	54.00 av	-9.52	101	183
9641.86	29.42 pk	38.84	3.94	24.84	47.36 pk	54.00 av	-6.64	102	7

Note:

- According to the standards used, Where limits are specified by agencies for both average and peak (or quasi-peak) detection , if the peak (or quasi-peak) measured value complies with the average limit , it is unnecessary to perform an average measurement.
- “ * ”: Fundamental Frequency
- “***”: Not in the restricted band, Limit level=Fundamental Emission-20dB
- “ pk ”: peak mode
- “ av ”: average mode
- “ --- ”: No meter reading data due to the emission level is smaller than spectrum noise level.
- The Spectrum noise level+Correction Factor < Limit - 6 dB
- Margin=Corrected Amplitude – Limit
- Corrected Amplitude=Radiated Amplitude+Antenna Correction Factor+Cable Loss-Pre-Amplifier Gain
- A margin of -8dB means that the emission is 8dB below the limit.

All frequencies from 1GHz to 25 GHz have been tested.

1GHz~ 25 GHz (Horizontal) , Channel 6 : 2437 MHz

Operator: Jerry Chiou

RBW: 1MHz
Humidity (%): 39
Temperature (C): 26

Frequency	Rx_R.	Ant_F.	Cab_L.	PreAmpl	Emission	Limit	Margin	A.Tower	T.Table
MHz	dBuV	dB/m	dB	dB	dBuV/m	dBuV/m	dB	cm	deg
1846.65	35.93 pk	29.71	2.49	23.75	44.38 pk	54.00 av	-9.62	100	54
1931.57	35.23 pk	30.43	2.55	23.75	44.45 pk	54.00 av	-9.55	100	48
1999	34.97 pk	30.99	2.60	23.75	44.81 pk	54.00 av	-9.19	100	43
2066.43	35.47 pk	30.99	2.40	23.89	44.96 pk	54.00 av	-9.04	100	64

1GHz~ 25 GHz (Vertical), Channel 6 : 2437 MHz

Operator: Jerry Chiou

RBW: 1MHz
Humidity (%): 39
Temperature (C): 26

Frequency	Rx_R.	Ant_F.	Cab_L.	PreAmpl	Emission	Limit	Margin	A.Tower	T.Table
MHz	dBuV	dB/m	dB	dB	dBuV/m	dBuV/m	dB	cm	deg
1844.16	36.15 pk	29.69	2.48	23.75	44.57 pk	54.00 av	-9.43	100	54
1891.61	35.27 pk	30.09	2.52	23.75	44.12 pk	54.00 av	-9.88	100	50
2038.96	34.55 pk	30.99	2.48	23.83	44.19 pk	54.00 av	-9.81	100	55

Note:

- According to the standards used, Where limits are specified by agencies for both average and peak (or quasi-peak) detection , if the peak (or quasi-peak) measured value complies with the average limit , it is unnecessary to perform an average measurement.
- “ * ”: Fundamental Frequency
- “**”: Not in the restricted band, Limit level=Fundamental Emission-20dB
- “ pk” : peak mode
- “ av” : average mode
- “---“: No meter reading data due to the emission level is smaller than spectrum noise level.
- The Spectrum noise level+Correction Factor < Limit - 6 dB
- Margin=Corrected Amplitude – Limit
- Corrected Amplitude=Radiated Amplitude+Antenna Correction Factor+Cable Loss-Pre-Amplifier Gain
- A margin of -8dB means that the emission is 8dB below the limit.

All frequencies from 1GHz to 25 GHz have been tested.

1GHz~ 25 GHz (Horizontal), Channel 11: 2462 MHz

Operator: Jerry Chiou

RBW: 1MHz
 Humidity (%): 39
 Temperature (C): 26

Frequency MHz	Rx_R. dBuV	Ant_F. dB/m	Cab_L. dB	PreAmpl dB	Emission dBuV/m	Limit dBuV/m	Margin dB	A.Tower cm	T.Table deg
1979.02	34.77 pk	30.82	2.58	23.75	44.42 pk	54.00 av	-9.58	100	44
2158.84	35.60 pk	30.97	2.12	24.09	44.59 pk	54.00 av	-9.41	100	93
2298.7	36.66 pk	30.94	1.69	24.40	44.90 pk	54.00 av	-9.10	101	137
2523.48	40.26 pk	30.91	1.36	24.85	47.68 pk	54.00 av	-6.32	102	207

1GHz~ 25 GHz (Vertical), Channel 11 : 2462 MHz

Operator: Jerry Chiou

RBW: 1MHz
 Humidity (%): 39
 Temperature (C): 26

Frequency MHz	Rx_R. dBuV	Ant_F. dB/m	Cab_L. dB	PreAmpl dB	Emission dBuV/m	Limit dBuV/m	Margin dB	A.Tower cm	T.Table deg
1846.65	36.33 pk	29.71	2.49	23.75	44.78 pk	54.00 av	-9.22	100	54
1984.02	34.72 pk	30.87	2.59	23.75	44.42 pk	54.00 av	-9.58	100	44
2171.33	35.47 pk	30.97	2.08	24.12	44.39 pk	54.00 av	-9.61	101	97
2283.72	36.29 pk	30.94	1.73	24.36	44.60 pk	54.00 av	-9.40	101	132

Note:

- According to the standards used, Where limits are specified by agencies for both average and peak (or quasi-peak) detection , if the peak (or quasi-peak) measured value complies with the average limit , it is unnecessary to perform an average measurement.
- “ * ”: Fundamental Frequency
- “**”: Not in the restricted band, Limit level=Fundamental Emission-20dB
- “ pk”: peak mode
- “av”: average mode
- “---“: No meter reading data due to the emission level is smaller than spectrum noise level.
- The Spectrum noise level+Correction Factor < Limit - 6 dB
- Margin=Corrected Amplitude – Limit
- Corrected Amplitude=Radiated Amplitude+Antenna Correction Factor+Cable Loss-Pre-Amplifier Gain
- A margin of -8dB means that the emission is 8dB below the limit.

All frequencies from 1GHz to 25 GHz have been tested.

5.5 Band Edge Measurement

5.5.1 Test Procedure (Conducted)

1. The transmitter output of EUT was connected to the spectrum analyzer.
 Equipment mode: Spectrum analyzer
 Detector function: Peak mode
 SPAN: 100MHz
 RBW: 100KHz
 VBW: 100KHz
 Center frequency: 2.4GHz, 2.4835GHz.
2. Using Peak Search to read the peak power of Carrier frequencies after Maximum Hold function is completed
3. Find the next peak frequency outside the operation frequency band

5.5.2 Test Setup (Conducted)

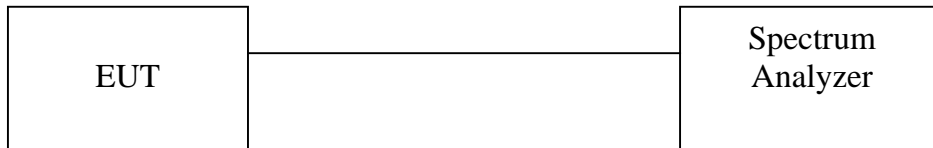

5.5.3 Test Data:

Table: Band Edge measurement (Conducted)

Temp. (deg. C): 25
 Humidity (%): 50
 Test Engr: Jerry Chiou

Channel	Frequency	Spectrum Reading	Carrier - Outsideband Limit: >20dB	Pass/Fail
	(MHz)		(dB)	
1	2413.4	101.9	---	---
Outside band	2400	72.63	29.27	Pass
11	2463.5	101.65	---	---
Outside band	2487.1	54.76	46.89	Pass

Band Edge Conducted measurement



Band Edge Conducted Measurement

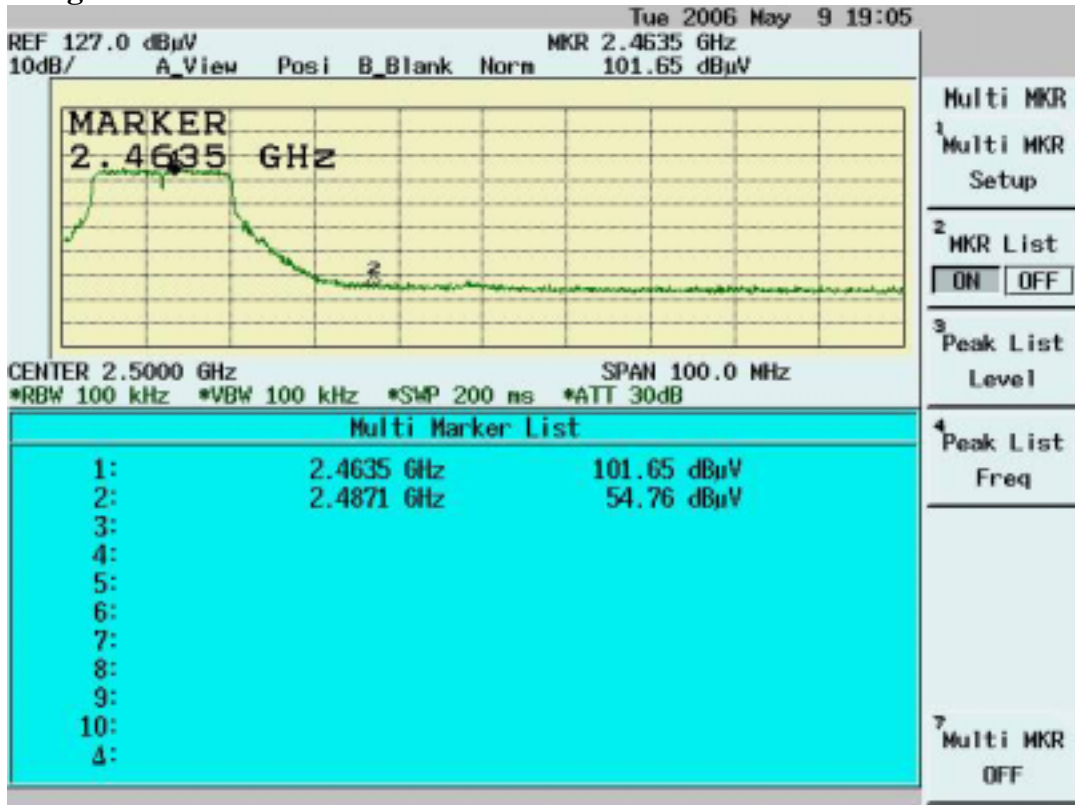

5.5.4 Test Procedure (Radiated)

1. Antenna and Turntable test procedure same as Radiated Emission Measurement.
Equipment mode: Spectrum analyzer
Detector function: Peak mode
SPAN: 100MHz
RBW: 1MHz
VBW: 3MHz
Center frequency: 2.395GHz, 2.48GHz.
2. Using Peak Search to read the peak power of Carrier frequencies after Maximum Hold function is completed.
3. Find the next peak frequency outside the operation frequency band
4. For peak frequency emission level measurement in Restricted Band ,
Change RBW: 1MHz
VBW: 10Hz
Span: 100MHz.
5. Get the spectrum reading after Maximum Hold function is completed.

5.5.5 Test Setup (Radiated)

Same as *Radiated Emission Measurement*

5.5.6 Test Data

Table Band Edge measurement (Radiated)

Temp. (deg. C): 25

Test Engr: Jerry Chiou Humidity (%): 50

Description	Frequency	Spectrum	Correction	Emission	dBc	Limit	Equip.	Pass
	(MHz)	Reading (dBuV)	Factor (dB/m)	Level (dBuV/m)	(Limit: > 20dBc)	(dBuV/m)	Setup VBW	or Fail
Channel_1 (average mode)	2418.6	57.67	35.48	93.15	---	---	10Hz	---
Channel_1 (peak mode)	2418.2	68.3	35.48	103.78	---	---	3MHz	---
Outside band (peak mode)	2400	37.24	35.48	72.72	31.06	---	3MHz	Pass
Channel_11 (average mode)	2463.6	58.46	35.5	93.96	---	---	10Hz	---
Channel_11 (peak mode)	2464.4	68.73	35.5	104.23	---	---	3MHz	---
Outside band (peak mode)	2498.5	18.69	35.51	54.2	50.03	---	3MHz	Pass
Channel_1 Restricted band (peak mode)	2380.2	20.3	35.47	55.77	---	74	3MHz	Pass
Restricted band (average mode)	2390	7.84	35.47	43.31	---	54	10Hz	Pass
Channel_11 Restricted band (peak mode)	2498.5	18.69	35.51	54.2	---	74	3MHz	Pass
Restricted band (average mode)	2498.5	8.01	35.51	43.52	---	54	10Hz	Pass

Note:

- The Spectrum plot of emission level measurement in Restricted band is attached.
- Emission Level=Spectrum Reading+Correction Factor
- Correction Factor=Antenna Factor+cable loss–amplifier gain
- Both Horizontal and Vertical polarizaion have been tested and the worst data is listed above.

Band Edge measurement for radiated emission in Restricted Band(Radiated) Peak Mode (Channel 1)

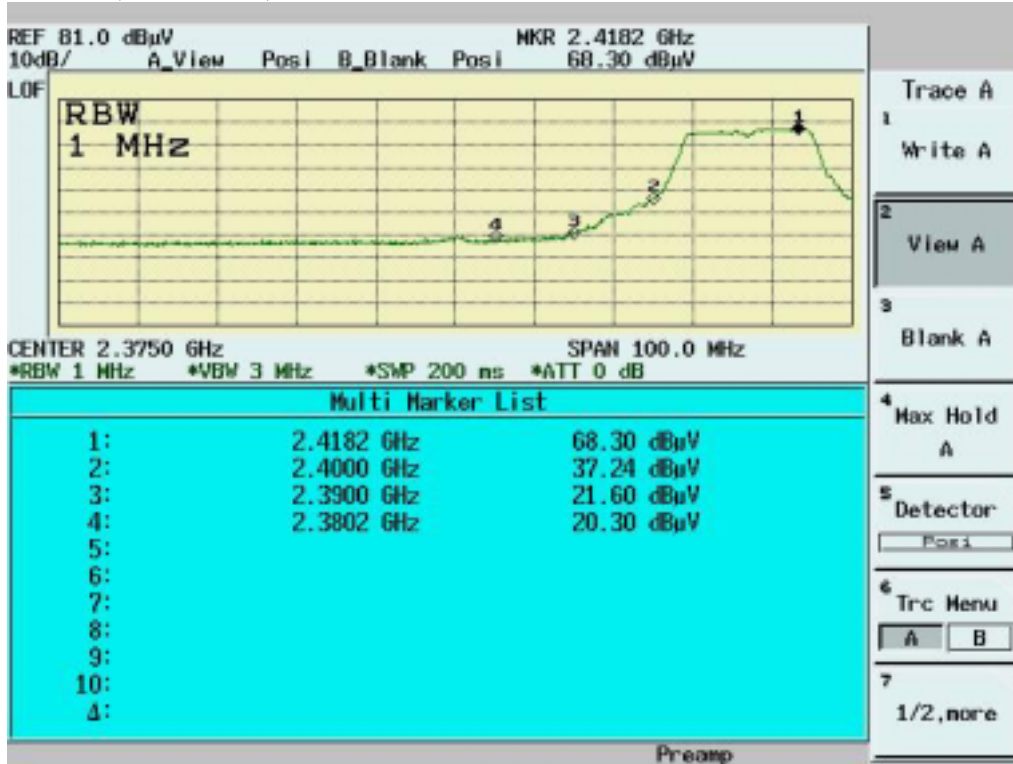

Band Edge measurement for radiated emission in Restricted Band(Radiated) Average Mode (Channel 1)

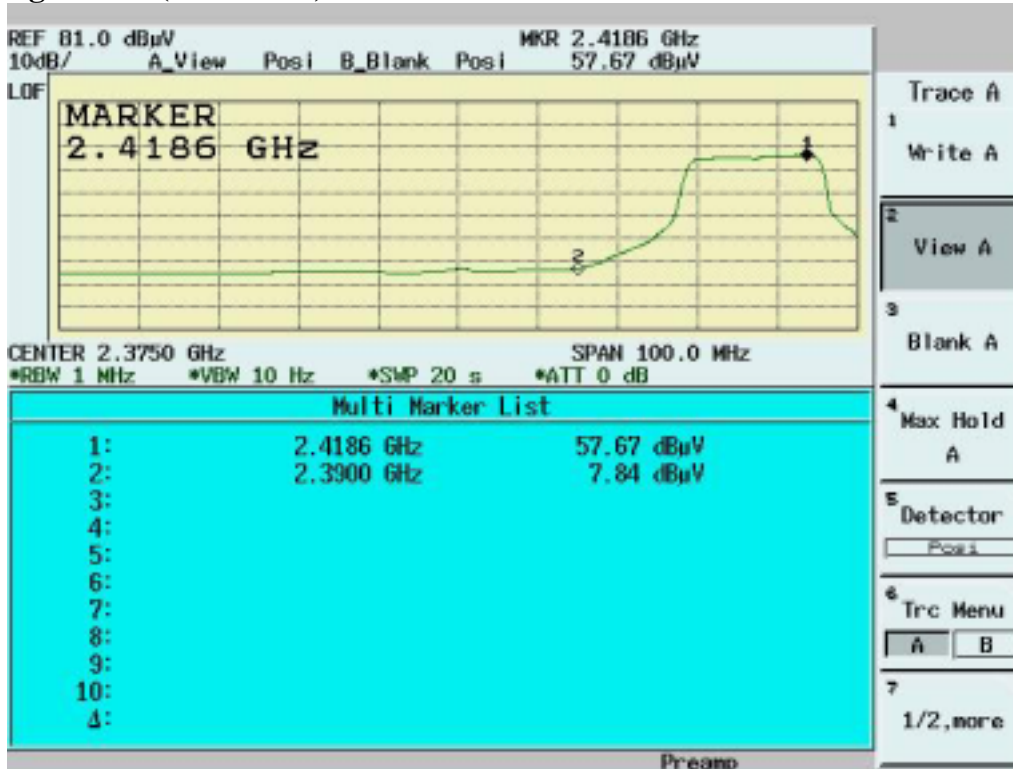

Band Edge measurement for radiated emission in Restricted Band(Radiated) Peak Mode (Channel 11)

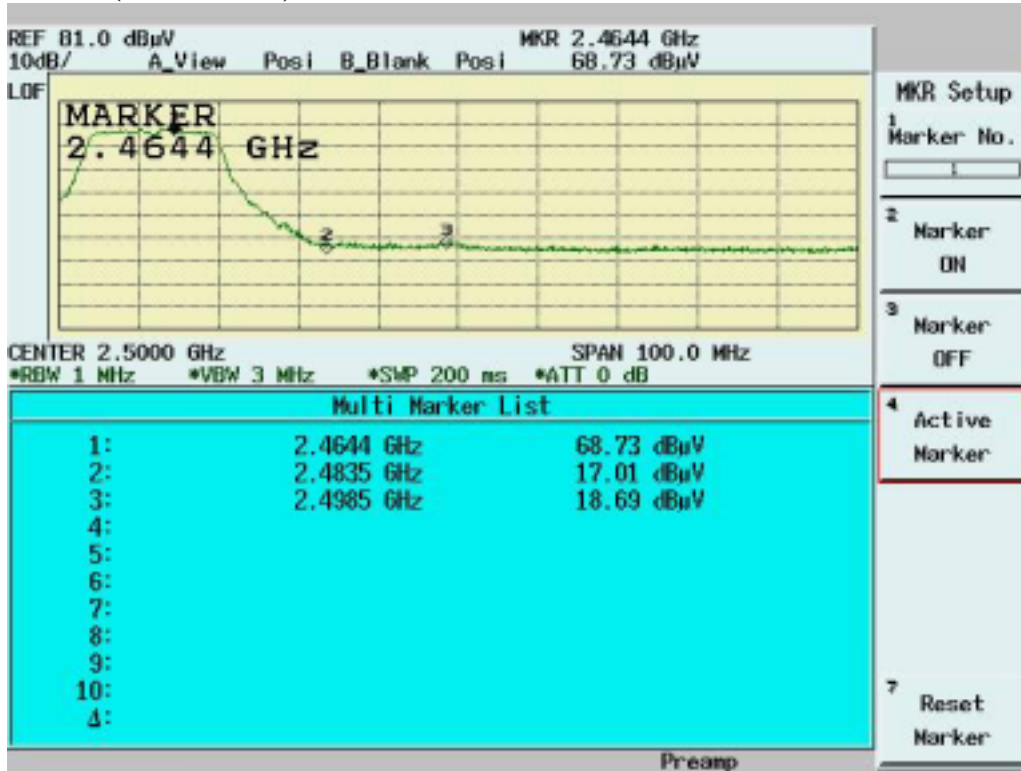

Band Edge measurement for radiated emission in Restricted Band(Radiated) Average Mode (Channel 11)

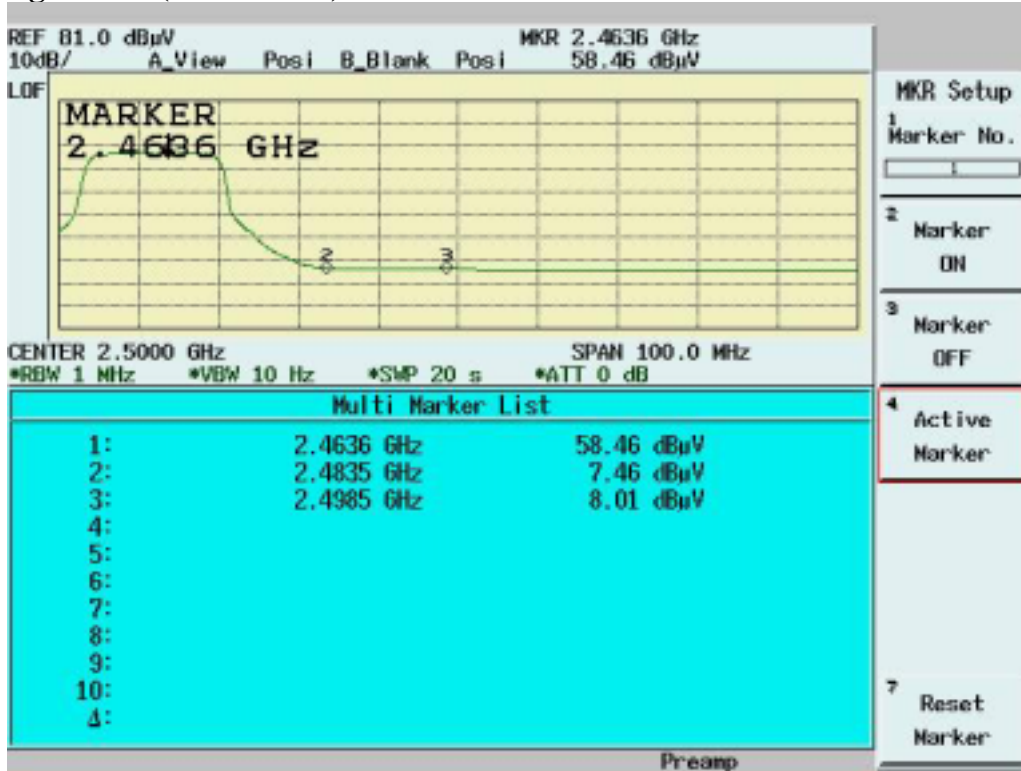



5.6 RF Exposure Measurement [Section 15.247(b)(4) & 1.1307(b)]

See SAR report

5.7 DSSS Peak Power Spectral Density [Section 15.247(d)]

5.7.1 Test Procedure

1. The Transmitter output of EUT was connected to the spectrum analyzer.
 Equipment mode: Spectrum analyzer
 Detector function: Peak mode
 SPAN: 1.5MHz
 RBW: 3KHz
 VBW: 30KHz
 Center frequency: fundamental frequency tested.
 Sweep time= 500 sec.
2. Using Peak Search to read the peak power after Maximum Hold function is completed.

5.7.2 Test Setup



5.7.3 Test Data

Maximum Peak Output Power Density

Temp. (deg. C): 25

Test Engr: Jerry Chiou

Humidity (%): 50

Chennel	Frequency (MHz)	Spectrum Reading (dBm/3KHz)	Cable Loss (dB)	Peak Power Output (dBm/3KHz)	Limit (dBm/3KHz)	Pass/Fail
1	2412	-19.41	1.1	-18.31	8	Pass
6	2437	-19.45	1.1	-18.35	8	Pass
11	2462	-18.97	1.1	-17.87	8	Pass

Channel 1



Channel 6

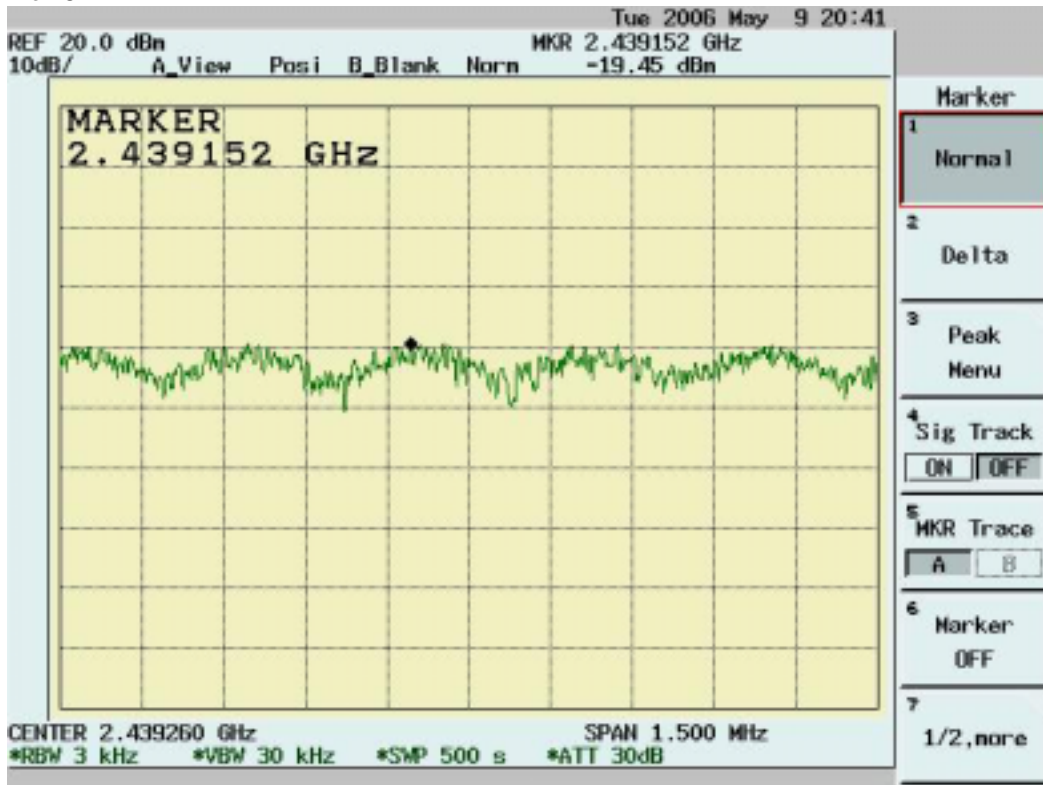

Channel 11



6. Appendix

6.1 Appendix A: Measurement Procedure for Power line Conducted Emissions

The measurements are performed in a 3.5m x 3.4m x 2.5m shielded room, which referred as Conduction 01 test site, or a 3m x 3m x 2.3m test site, which referred as Conduction 02 test site. The EUT was placed on non-conduction 1.0m x 1.5m table, which is 0.8 meters above an earth-grounded.

Power to the EUT was provided through the LISN which has the Impedance (50ohm/50uH) vs. Frequency Characteristic in accordance with the required standard. Power to the LISNs were filtered to eliminate ambient signal interference and these filters were bonded to the ground plane. Peripheral equipment required to provide a functional system (support equipment) for EUT testing was powered from the second LISN through a ganged, metal power outlet box which is bonded to the ground plane at the LISN.

If the EUT is supplied with a flexible power cord, the power cord length in excess of the distance separating the EUT from the LISN shall be folded back and forth at the center of the lead so as to form a bundle not exceeding 40cm in length. If the EUT is provided with a permanently coiled power cord, bundling of the cord is not required. If the EUT is supplied without a power cord, the EUT shall be connected to the LISN by a power cord of the type specified by the manufacturer which shall not be longer than 1 meter. The excess power cord shall be bundled as described above. If a non-flexible power cord is provided with the EUT, it shall be cut to the length necessary to attach the EUT to the LISN and shall not be bundled.

The interconnecting cables were arranged and moved to get the maximum emission. Both the line of power cord, hot and neutral, were measured.

The highest emissions were analyzed in details by operating the spectrum analyzer in fixed tuned mode to determine the nature of the emissions and to provide information which could be useful in reducing their amplitude.

6.2 Appendix B: Test Procedure for Radiated Emissions

Preliminary Measurements in the Anechoic Chamber

The radiated emissions are initially measured in the anechoic chamber at a measurement distance of 3 meters. Desktop EUT are placed on a wooden stand 0.8 meter in height. The measurement antenna is 3 meters from the EUT. The test setup in anechoic chamber is the same as open site. The turntable rotated 360°C. The antenna height is varied from 1-2.5m. The primary objective of the radiated measurements in the anechoic chamber is to identify the frequency spectrum in the absence of the electromagnetic environment existing on the open test site. The frequencies can then be pre-selected on the open test site to obtain the corresponding amplitude. The initial scan is made with the spectrum analyzer in automatic sweep mode. The spectrum peaks are then measured manually to determine the exact frequencies.

Measurements on the Open Site or 10m EMC Chamber

The radiated emissions test will then be repeated on the open site or 10m EMC chamber to measure the amplitudes accurately and without the multiple reflections existing in the shielded room. The EUT and support equipment are set up on the turntable of one of the 3 or 10 meter open field sites. Desktop EUT are set up on a wooden stand 0.8 meter above the ground.

For the initial measurements, the receiving antenna is varied from 1-4 meter height and is changed in the vertical plane from vertical to horizontal polarization at each frequency. Both reading are recorded with the quasi-peak detector with 120KHz bandwidth. For frequency between 30 MHz and 1000MHz, the reading is recorded with peak detector or quasi-peak detector. For frequency above 1 GHz, the reading is recorded with peak detector or average detector with 1 MHz bandwidth.

At the highest amplitudes observed, the EUT is rotated in the horizontal plane while changing the antenna polarization in the vertical plane to maximize the reading. The interconnecting cables were arranged and moved to get the maximum emission. Once the maximum reading is obtained, the antenna elevation and polarization will be varied between specified limits to maximize the readings.

6.3 Appendix C: Test Equipment

6.3.1 Test Equipment List

Location	Equipment Name	Brand	Model	S/N	Last Cal. Date	Next Cal. Date
Conduction	Coaxial Cable 1F-C2	Harbourindustries	RG400	1F-C2	05/20/2005	05/20/2006
Conduction	Digital Hygro-Thermometer Conduct	MicroLife	HT-2126G	ISL-Conduction02	11/30/2004	11/30/2006
Conduction	EMI Receiver 02	HP	85460A	3448A00183	10/01/2005	10/01/2006
Conduction	LISN 01	R&S	ESH2-Z5	890485/013	05/05/2006	05/05/2007
Conduction	LISN 06	R&S	ESH3-Z5	828874/009	12/13/2005	12/13/2006
Radiation	BILOG Antenna 08	Schaffner	CBL6112B	2756	06/07/2005	06/07/2006
Radiation	Coaxial Cable Chmb 02-10M	Belden	RG-8/U	Chmb 02-10M	12/28/2005	12/28/2006
Radiation	Digital Hygro-Thermometer Chmb 02	MicroLife	HT-2126G	Chmb 02	11/30/2004	12/30/2006
Radiation	EMI Receiver 03	HP	85460A	3448A00209	04/01/2006	04/01/2007
Radiation	Spectrum Analyzer 13	Advantest	R3132	121200411	02/17/2006	02/17/2007
Radiation	Horn Antenna 02	Com-Power	AH-118	10088	07/22/2005	07/22/2006
Radiation	Horn Antenna 04	Com-Power	AH-826	081-001	01/13/2006	01/13/2007
Radiation	Horn Antenna 05	Com-Power	AH-640	100A	09/30/2005	09/30/2006
Radiation	Microwave Cable RF SK-01	HUBER+SUHNERAG.	Sucoflex 102	22139 /2	07/07/2005	07/07/2006
Chamber 05	Peak Power Analyzer	HP	8990A	3621A01269	03/28/2006	03/28/2007
Chamber 05	Power Sensor Radar	HP	84815A	3318A01828	03/28/2006	03/28/2007
Radiation	Preamplifier 02	MITEQ	AFS44-00102 650-40-10P-44	728229	11/28/2005	11/28/2006
Radiation	Preamplifier 10	MITEQ	JS-26004000-2 7-5A	818471	11/22/2005	11/22/2006
Radiation	High Pass Filter 01	HEWLETT-PACKARD	84300-80038	001	N/A	N/A
Radiation	High Pass Filter 02	HEWLETT-PACKARD	84300-80039	005	N/A	N/A
Radiation	Spectrum Analyzer 14	Advantest	R3182	140600028	11/22/2005	11/22/2006

Note: Calibration is traceable to NIST or national or international standards.

6.3.2 Software for Controlling Spectrum/Receiver and Calculating Test Data

Radiation/Conduction	Filename	Version	Issued Date
Conduction	Tile.exe	1.12E	7/7/2000
Radiation	Tile.exe	1.12C	6/16/2000

6.4 Appendix D: Layout of EUT and Support Equipment

6.4.1 General Conducted Test Configuration

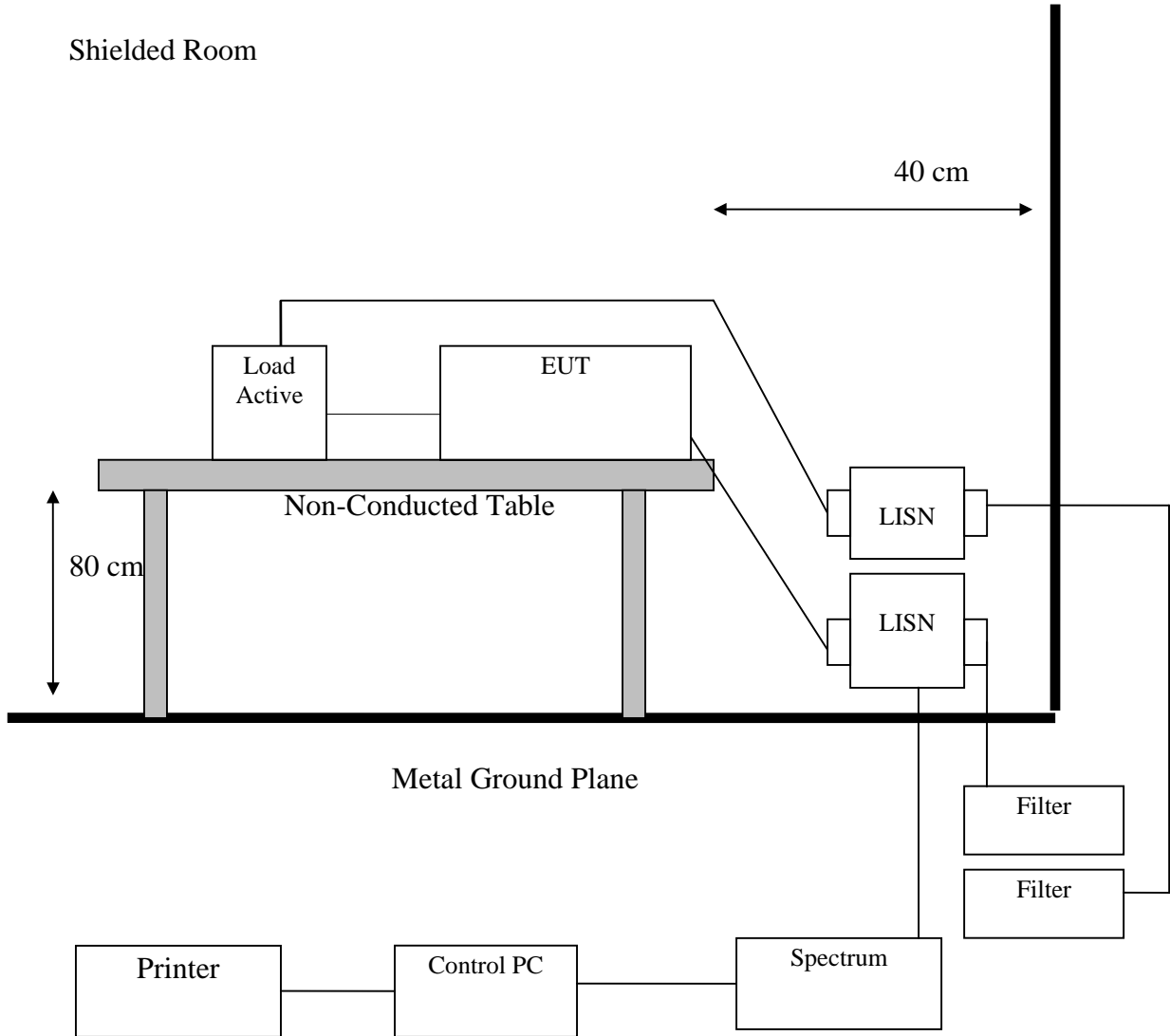

6.4.2 General Radiation Test Configuration

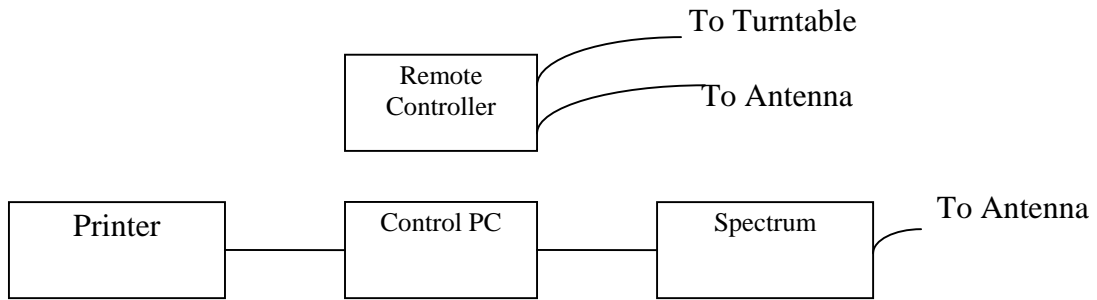
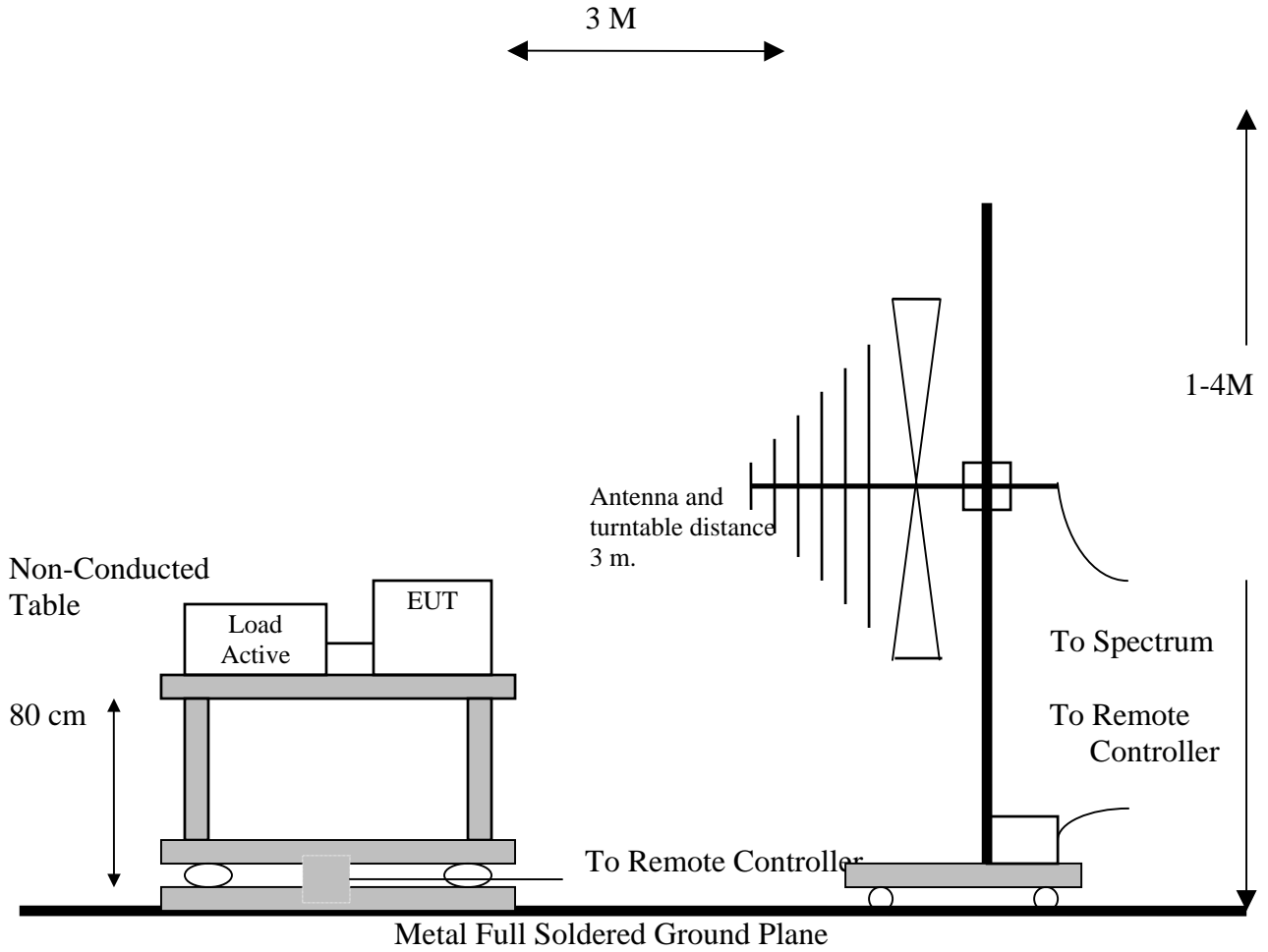

6.5 Appendix E: Description of Support Equipment

6.5.1 Description of Support Equipment

Support Unit 1.

Description:	Notebook Personal Computer
Model:	2371
Serial Number:	N/A
Power Supply Type:	Switching AC Adapte 56W Lite-On (Model: 02K6809) 3 pins
CPU Type:	Intel Pentium-M 1.2 GHz
Hard Disk Device:	Hitachi 20GB (Model: HTC424020F7AT00)
DDR:	256MB Infineon (Model: HYB25D256160BT-6)
BT/MODEM card:	Actiontec (Model: BMDC200)
Wireless card:	Phillips (Model: WLAN 802.11ABG 930700811107 WW)
DC-In:	one
VGA Port:	one
USB2.0 Connector:	two
LAN Connector:	one
Modem Port:	one
PCIMCIA Connector:	one
SD Connector	one
Docking Connector:	one
Battery:	Sanyo 4 cell (Model: 92P0999)
Power Cord:	Shielded 3 PIN, 2 PIN
LCD:	Samsung 12.1" XGA TFT (Model: LTN121XA-L01)
Maximum display Resolution:	1024X768 Non-interlaced

Support Unit 2.

Description:	DELL USB Mouse
Model Number:	M-UR69
Serial Number:	LNA24412741
Power Supply Type:	N/A
Power Cord:	N/A
FCC ID:	(Complied with FCC DOC)

Support Unit 3.

Description: Philips Monitor
Model: 201P10
Serial Number: TY100134004889
Power Cord: Non-shielded, Detachable
FCC ID: (Complied with FCC Standards)

6.5.2 Software for Controlling Support Unit

Test programs exercising various part of EUT were used. The programs were executed as follows:

- A. Read and write to the disk drives.
- B. The RF software makes the transmitter continuously sending RF signals
- C. Repeat the above steps.

	Filename	Issued Date
Setup Continuous Transmit-Receive 2.4.1.1	cTxRx.exe	2004/08/13

6.5.3 I/O Cable Condition of EUT and Support Units

Description	Path	Cable Length	Cable Type	Connector Type
AC Power Cord	110V (~240V) to AC Power Cord Inlet (3-pin)	1.8M	Nonshielded, Detachable	Plastic Head
Monitor Data Cable	Monitor to PC VGA port	1.6M	Shielded, Un-detachable	Metal Head
Mouse Data Cable	Mouse to PC Mouse port	1.8M	Shielded, Un-detachable	Metal Head

6.6 Appendix F: Accuracy of Measurement

Test Site: Conduction 02

Item	Source of Uncertainty	Probability Distribution	Total Uncertainties (dB)		Standard Uncertainty (dB)	
			k	Value	k	Value
1	Systematic Effects: (Assessment from 20 repeat observation; 1 reading on EUT)	Normal	k=2	0.104	k=1	0.052
2	Random Effects: (Assessment from 20 random observations; 1 reading on EUT)	Normal	k=2	0.330	k=1	0.165
3	Receiver Calibration	Rectangular	k=1.73	1.000	k=1	0.577
4	LISN Factor Calibration	Normal	k=2	1.200	k=1	0.600
5	Cable Loss Calibration	Normal	k=2	1.000	k=1	0.500
6	Combined Standard Uncertainty $U_c(y)$	Normal			k=1	0.850
7	Total Uncertainty @95% min. Confidence Level	Normal	k=2	1.701		

Measurement Uncertainty Calculations:

$$U_c(y) = \text{square root} (u_1(y)^2 + u_2(y)^2 + \dots + u_n(y)^2)$$

$$U = 2 * U_c(y)$$

Note: The measurement Uncertainties mentioned above also refer to NIS 81-1994 of NAMAS :
The treatment of Uncertainty in EMC Measurement.

Test Site: Chamber 02-3M

Item	Source of Uncertainty	Probability Distribution	Total Uncertainties (dB)		Standard Uncertainty (dB)	
			k	Value	k	Value
1	Systematic Effects: (Assessment from 20 repeat observation; 1 reading on EUT)	Normal	k=2	0.067	k=1	0.034
2	Random Effects: (Assessment from 20 random observations; 1 reading on EUT)	Normal	k=2	0.103	k=1	0.052
3	Receiver Calibration	Rectangular	k=1.73	1.000	k=1	0.577
4	Antenna Factor Calibration	Normal	k=2	1.700	k=1	0.850
5	Cable Loss Calibration	Normal	k=2	1.000	k=1	0.500
6	Combined Standard Uncertainty Uc(y)	Normal			k=1	1.029
7	Total Uncertainty @95% mim. Confidence Level	Normal	k=2	2.059		

Measurement Uncertainty Calculations:

$$U_c(y) = \text{square root} (u_1(y)^2 + u_2(y)^2 + \dots + u_n(y)^2)$$

$$U = 2 * U_c(y)$$

Note: The measurement Uncertainties mentioned above also refer to NIS 81-1994 of NAMAS :
The treatment of Uncertainty in EMC Measurement.

6.7 Appendix G: Photographs of EUT Configuration Test Set Up

The Front View of Highest Conducted Set-up For EUT



The Back View of Highest Conducted Set-up For EUT

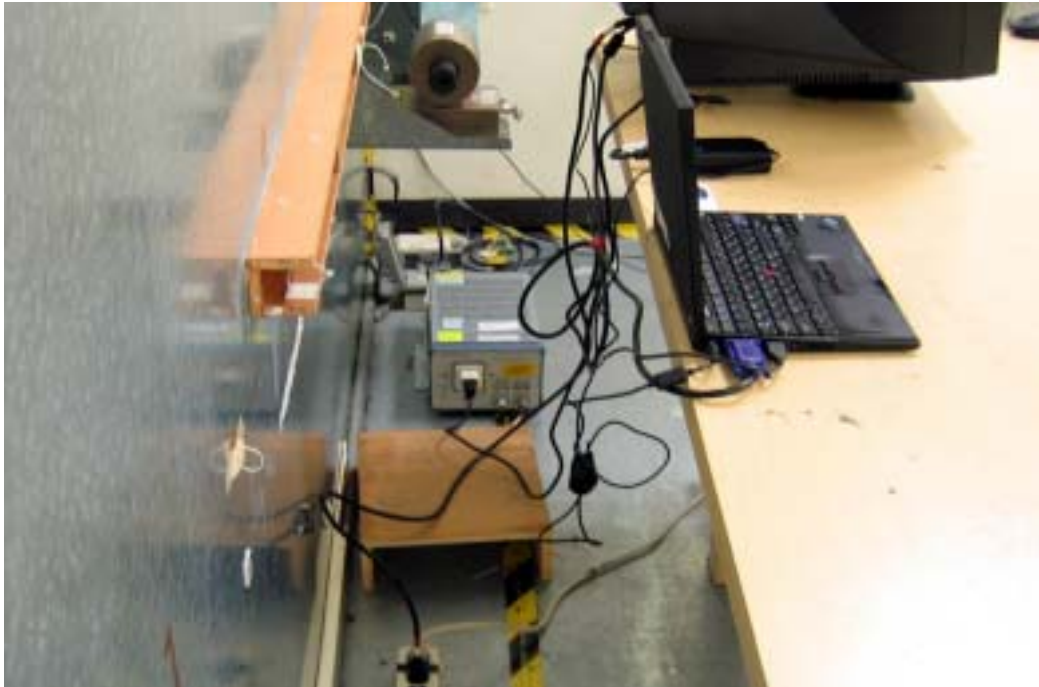

The Front View of Highest Radiated Set-up For EUT

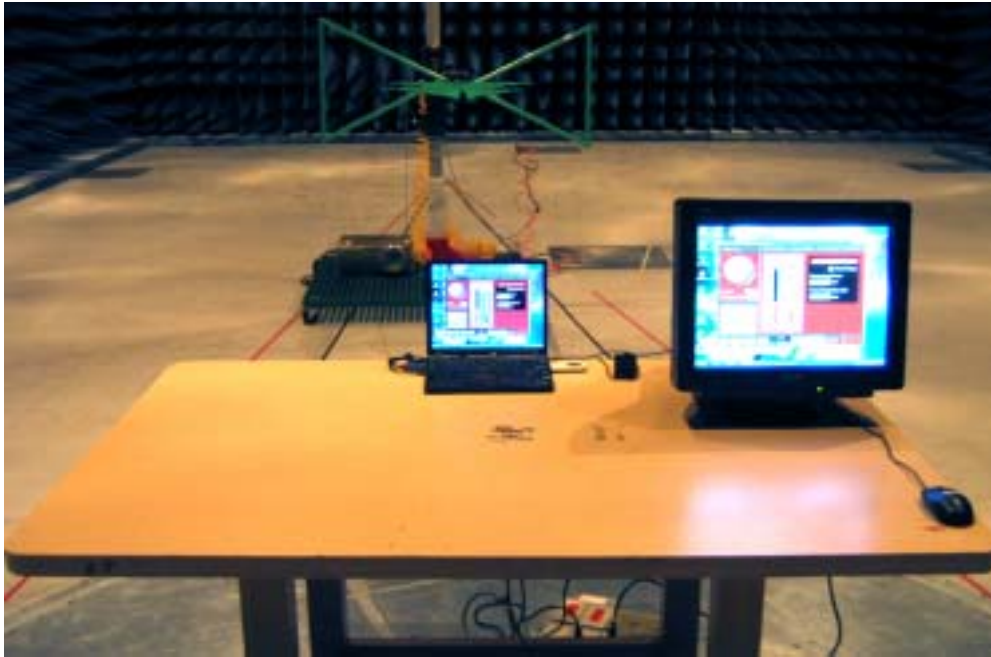

The Back View of Highest Radiated Set-up For EUT

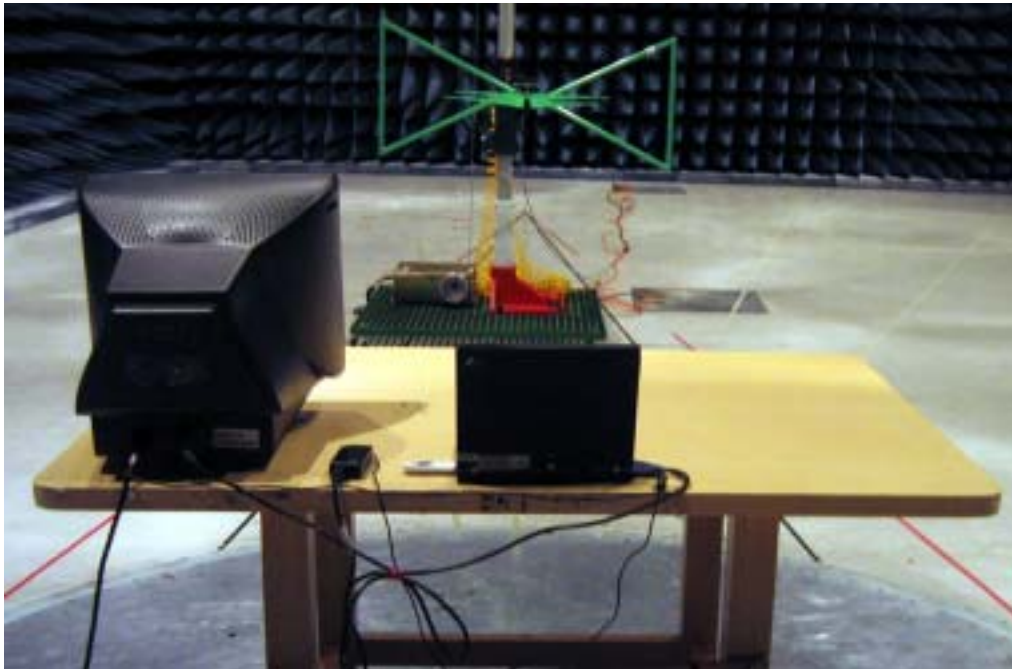

6.8 Appendix H: Antenna Spec.

Please refer to the attached file.