

UMC-A18QA LGA-type LTE Module

User Manual

Wistron NeWeb Corp.

啟碁科技股份有限公司

Revision History

Version	Change history	Date
0.1	Preliminary release	2018/06/01

CONFIDENTIAL

THIS DOCUMENT CONTAINS PROPRIETARY TECHNICAL INFORMATION, WHICH IS THE PROPERTY OF THE WISTRON NEWEB CORPORATION AND SHALL NOT BE DISCLOSED TO OTHERS IN WHOLE OR IN PART, REPRODUCED, COPIED, OR USED AS THE BASIS FOR DESIGN, MANUFACTURING, OR SALE OF APPARATUS WITHOUT WRITTEN PERMISSION OF WISTRON NEWEB CORPORATION.

CONTENTS

A.	Product Description	3
B.	Main Features	6
	B.1 Application interface features.....	7
	B.2 Packet mode features	7
	B.3 LTE features.....	7
	B.4 Short Message Service (SMS) features.....	7
	B.5 RF Specification	8
E.	Mounting considerations	9
F.	Mechanic Specifications	10
G.	Package Specifications	12
H.	Label Form.....	12
I.	Electrostatic discharge (ESD).....	13

A. PRODUCT DESCRIPTION

© Wistron NeWeb Corporation

THIS DOCUMENT AND THE INFORMATION CONTAINED HEREIN IS PROPRIETARY AND IS THE EXCLUSIVE PROPERTY OF WNC AND SHALL NOT BE DISTRIBUTED, REPRODUCED, OR DISCLOSED IN WHOLE OR IN PART WITHOUT PRIOR WRITTEN PERMISSION FROM WNC.

LIMITATION OF LIABILITY

THIS DOCUMENT AND THE INFORMATION CONTAINED HEREIN IS PURELY FOR DESIGN REFERENCE AND SUBJECT TO REVISION BY WNC AT ANY TIME. NOTHING IN THIS DOCUMENT SHALL BE CONSTRUED AS GRANTING ANY WARRANTY OR RIGHT TO USE THE MATERIAL CONTAINED HEREIN WITHOUT WNC'S PRIOR EXPRESS WRITTEN CONSENT. WNC SHALL NOT BE LIABLE FOR ANY USE, APPLICATION OR DEVELOPMENT DERIVED FROM THE MATERIAL WITHOUT SUCH PRIOR EXPRESS WRITTEN CONSENT.

FCC Regulations:

This device complies with part 15 of the FCC Rules. Operation is subject to the following two conditions: (1) This device may not cause harmful interference, and (2) This device must accept any interference received, including interference that may cause undesired operation.

This device has been tested and found to comply with the limits for a Class B digital device, pursuant to Part 15 of the FCC Rules. These limits are designed to provide reasonable protection against harmful interference in a residential installation. This equipment generates, uses and can radiated radio frequency energy and, if not installed and used in accordance with the instructions, may cause harmful interference to radio communications. However, there is no guarantee that interference will not occur in a particular installation. If this equipment does cause harmful interference to radio or television reception, which can be determined by turning the equipment off and on, the user is encouraged to try to correct the interference by one or more of the following measures:

- Reorient or relocate the receiving antenna.
- Increase the separation between the equipment and receiver.

-Connect the equipment into an outlet on a circuit different from that to which the receiver is connected.

-Consult the dealer or an experienced radio/TV technician for help.

Caution: Changes or modifications not expressly approved by the party responsible for compliance could void the user's authority to operate the equipment.

End Product Labeling

The final end product must be labeled in a visible area with the following: "Contains FCC ID: NKRA18QA". The grantee's FCC ID can be used only when all FCC compliance requirements are met.

RF Exposure Information

This device is intended only for ODM/OEM integrators under the following conditions:

- (1) The antenna must be installed such that 20cm is maintained between the antenna and users,
- (2) The transmitter module may not be co-located with any other transmitter or antenna.
- (3) To comply with FCC regulations limiting both maximum RF output power and human exposure to RF radiation, the maximum antenna gain including cable loss in a mobile exposure condition must not exceed:

Standalone Condition:

1.0 dBi in 700 MHz Band

1.5 dBi in 850 MHz Band

5.5 dBi in 1700 MHz Band

3.5 dBi in 1900 MHz Band

IMPORTANT NOTE:

This module is intended for ODM/OEM integrator. The integrator is still responsible for the FCC compliance requirement of the end product, which integrates this module. 20cm minimum distance has to be able to be maintained between the antenna and the users for the host this module is integrated into. Under such configuration, the FCC radiation exposure limits set forth for an population/uncontrolled environment can be satisfied.

Any changes or modifications not expressly approved by the manufacturer could void the user's authority to operate this equipment.

USERS MANUAL OF THE END PRODUCT:

In the users manual of the end product, the end user has to be informed to keep at least 20cm separation with the antenna while this end product is installed and operated. The end user has to be informed that the FCC radio-frequency exposure guidelines for an uncontrolled environment can be satisfied. The end user has to also be informed that any changes or modifications not expressly approved by the manufacturer could void the user's authority to operate this equipment. If the size of the end product is smaller than 8x10cm, then additional FCC part 15.19 statement is required to be available in the users manual: This device complies with Part 15 of FCC rules. Operation is subject to the following two conditions: (1) this device may not cause harmful interference and (2) this device must accept any interference received, including interference that may cause undesired operation.



Figure1: UMC-A18QA LGA-type LTE Module

A.1 General Descriptions

This document describes the specifications of UMC-A18QA LGA LTE Module. This module is based on Qualcomm MDM9207-0 platform and capable to allow users enjoying high speed internet access anywhere and anytime over 4G LTE broadband network.

With integrating UMC-A18QA module, the end products are enhanced in both functionality and usability based on leading edge mobile wireless technology.

This document will introduce hardware, software, mechanical and environmental specifications in following sections.

Product information:

Part Number	Category	LTE	GNSS	Footprint	Dimension
UMC-A18QA	CAT4	B2, B4, B5, B13	GPS	LGA 263 pads	28.5x23.5x2.3mm

A.2 Applicable Device

WNC UMC-A18QA module is a high speed LTE modem with LGA form factor and is focusing on the gateway, notebook, tablet and other portable device or M2M marketing.

- Notebook
- Tablet
- Mobile Internet Device
- Wireless Router
- Wireless Multimedia Device
- Wireless M2M solution

B. MAIN FEATURES

- Support 1.8/3.0V USIM
 - Operation System (OS) Support - Linux (device driver)
 - Certification
 - GCF/Verizon (in plan)
 - FCC (in plan)
 - Operating Ambient Temperature
-

Specification

- Operating : -30°C ~ +70°C
 - ◆ -20°C~+60°C: full functions compliant with 3GPP
 - ◆ -30°C~+70°C: functional workable
- Storage : -40°C ~ +85°C

B.1 APPLICATION INTERFACE FEATURES

- WNC MAL (Modem Abstraction Layer) Manager SDK for Linux

B.2 PACKET MODE FEATURES

- LTE data rates with category 4 (UMC-A18QA)
 - ◇ 75 Mbps DL with 15 MHz bandwidth
 - ◇ 37 Mbps UL with 15 MHz bandwidth

B.3 LTE FEATURES

- 3GPP LTE Release 9
- Bandwidth support 1.4 MHz, 3 MHz, 5 MHz, 10 MHz, 15 MHz per 3GPP standard
- VoLTE
- IPv4 and IPv6 supported
- LTE Rel-10 MDT with location information

B.4 SHORT MESSAGE SERVICE (SMS) FEATURES

- SMS over SGs
- SMS over IMS

B.5 RF SPECIFICATION

➤ Cellular Frequency Band

E-UTRA Operating Band	Uplink Frequency UE Transmit	Downlink Frequency UE Receive
Band 2	1850MHz - 1910 MHz	1930 MHz – 1990 MHz
Band 4	1710 MHz - 1755 MHz	2110 MHz - 2155 MHz
Band 5	824 MHz - 849 MHz	869 MHz - 894 MHz
Band 13	777 MHz - 787 MHz	746 MHz - 756 MHz

➤ LTE Channel Bandwidth

E-UTRA Operating Band	Channel Bandwidth (CHBW)					
	1.4 MHz	3 MHz	5 MHz	10 MHz	15 MHz	20 MHz
Band 2	Yes	Yes	Yes	Yes	Yes ¹	Yes ¹
Band 4	Yes	Yes	Yes	Yes	Yes	Yes
Band 5	Yes	Yes	Yes	Yes ¹		
Band 13			Yes ¹	Yes ¹		

Note 1: refers to the CHBW for which a relaxation of the specified UE receiver sensitivity requirement is allowed as defined in section 7.3 of 3GPP TS 36.101.

➤ LTE Max. TX Output Power

LTE Band	Items	Parameter Partial RB	Unit	Min	Typ	Max
----------	-------	-------------------------	------	-----	-----	-----

Specification

B2, B4, B5,B13	Max TX Power	QPSK-1RB#0, 10MHz	dBm	20.3		25.7
----------------	--------------	-------------------	-----	------	--	------

Note: The RF Transmit Specification is defined at the LGA pad.

➤ LTE Reference Sensitivity

LTE Band	Items	Parameter	Min	Typ	Max	Unit
Band 2	Receive Sensitivity	10MHz			-95.0	dBm
Band 4	Receive Sensitivity	10MHz			-97.0	dBm
Band 5	Receive Sensitivity	10MHz			-95.0	dBm
Band 13	Receive Sensitivity	10MHz			-94.0	dBm

Note: The RF Receive Specification is defined at the LGA pad.

➤ GPS Receive Specifications

The GPS is an optional feature in UMC-A18QA, depending on additional request.

E. MOUNTING CONSIDERATIONS

➤ Reflow soldering profile:

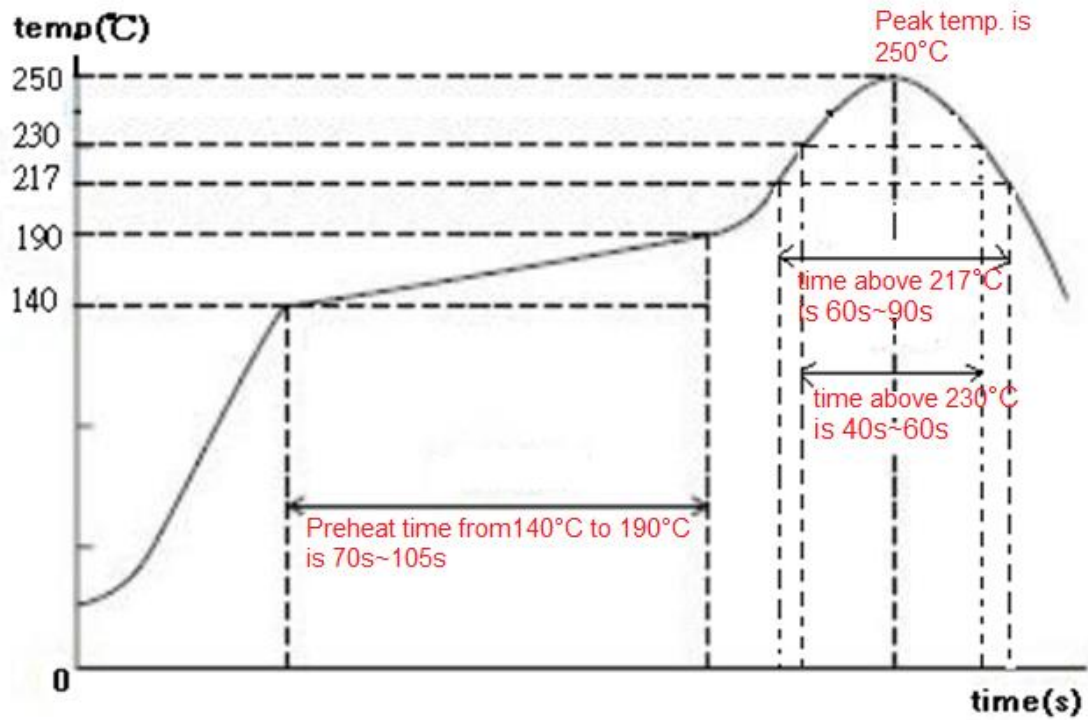

Profile	Min.	Max.	Unit
Preheat time from 140°C to 190°C	70	105	S
Time maintained above 230°C	40	60	S
Peak package body temperature	230	250	°C
Time maintained above 217°C	60	90	S

F. MECHANIC SPECIFICATIONS

- Dimension: 28.5mm [L] x 23.5mm [W] x 2.3mm [H]

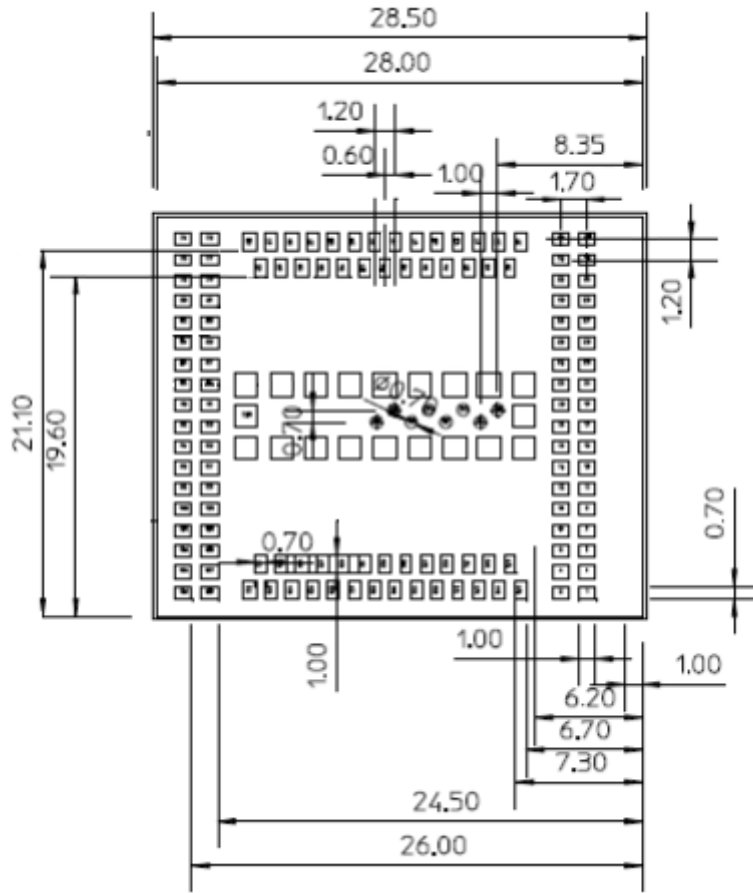

PCB FOOTPRINT (Top View)

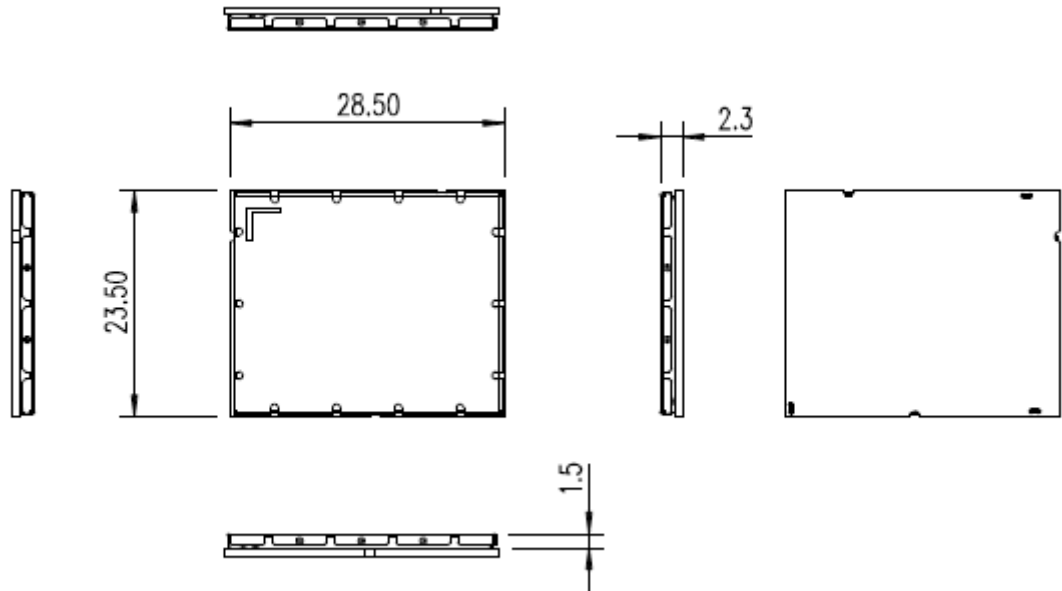

Module Dimension (Top and Side View)

G. PACKAGE SPECIFICATIONS

- Tape & Reel

H. LABEL FORM

- Dimension : 19mm * 19mm (example as shown below)

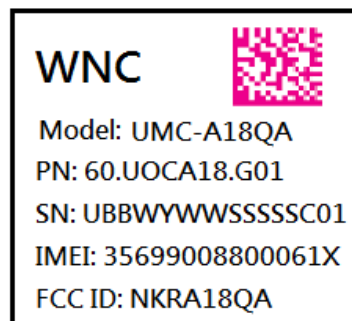

I. ELECTROSTATIC DISCHARGE (ESD)

+/- 2KV



20 Park Avenue II,

Hsinchu Science Park,

Hsinchu 308, Taiwan, R.O.C.

TEL: 886-3-666-7799

FAX: 886-3-666-7321

Website: <http://www.wnc.com.tw>